

INSTRUCTIONS FOR INSTALLING THE 178343, 178344, AND 178345 MODIFI-  
CATION KITS ON MODEL 28 SEND-RECEIVE SETS (KEYBOARDS LK6 AND UP)  
TO PROVIDE AN ANSWER-BACK MECHANISM

The chart below pertains to Bell System only.

Teletype Unit	Teletype Code	Bell System Reference	Bell Code
Keyboard (Send-Receive)	LK	Base	28D
		(Send-Receive)	28E

1. GENERAL

a. The 178343, 178344, and 178345 Modification Kits provide an answer-back mechanism on the Model 28 Send-Receive Page Printer Sets (LK6 and up) wired for either half-duplex or full-duplex and containing an electrical service unit (LESU). The answer-back mechanism is an electromechanical device which allows the identity of the called station to be transmitted automatically to the originating station on receipt of the sequential selection "FIGS" - "C" from the signal line.

b. For receiving tape transmission, a delay circuit is incorporated in the answer-back mechanism which permits the receipt of a third character following the sequential "FIGS" - "C" (i.e. "LTRS" in "FIGS" - "C" - "LTRS") before transmission of the answer-back message begins.

c. A control relay actuated by the local station signal generator prevents the local station answer-back mechanism from operating when a distant station has been called. Local answer-back may be operated from the local red "HERE IS" keylever.

d. A subset actuated relay initiates answer-back operation from a Bell System Data-Phone Subset.

e. All three kits are necessary to provide answer-back operation with Model 28 Send-Receive Sets (LK6 and up).

f. The 178343 Modification Kit provides only those parts of the answer-back mechanism common to the Model 28 Typing Unit (LP10 and up) and supplies the control from "FIGS" "C" keylever. The typing unit must have stunt box slots 31, 32, 33, and 34 available to utilize the 178343 Modification Kit.

© 1961 by Teletype Corporation  
All rights reserved.  
\*Indicates general revision

Printed in U.S.A.

g. The 178344 Modification Kit provides only those parts of the answer-back mechanism common to the Model 28 Keyboard (LK6 and up). The basic parts are a signal generator "pulsing" or "blinding" contact, basic answer-back mechanism, "Here Is" keylever and associated contact, "non-contention" or answer-back control relay, and diode to provide direct operating current to the answer-back trip magnet.

h. The answer-back device has a total capacity of 21 characters. The first character transmitted is always a "LETTERS" combination; the remaining 20 may be any characters desired. However, this first LTRS combination is normally followed by CARRIAGE RETURN and LINE FEED while the coding also normally ends with CARRIAGE RETURN and LINE FEED. This arrangement insures that the answer-back message will appear at the beginning of a line on the distant station and that over-printing of the message will not occur. Transmission of the of the LTRS combinations at the beginning of the message also returns all stations in the circuit to the unshift position. Since five of the 21 available characters are thus used to perform these functions, only 16 are available for the answer-back identification. This procedure may be altered to suit a particular application of the answer-back mechanism.

i. If the Send-Receive Set to be equipped with the answer-back mechanism does not have the double-blank keyboard lock modification kit, a station may accidentally interfere with the answer-back operation either by holding its own calling keylever depressed or by depressing any keylever during the operation of the answer-back mechanism. Warn the operator of this condition.

j. The trip magnet circuit of the answer-back mechanism is connected to the 115 volt 60 cycle  $\pm$  10% A.C. supply circuit of the Send-Receive Set. Diode CR2 rectifies the A.C. supply to provide an average direct operating current of approximately 0.070 amperes when the trip magnet circuit is completed through the "Here Is" contact or the subset actuated relay contacts. Sequential "FIGS" - "C" operation completes a circuit to the answer-back trip magnet which furnishes a direct time varying operating current. Peak operating current for 60 W.P.M. operation is 60 to 100 milliamperes D.C. Peak operating current for 100 W.P.M. operation is 60 to 75 milliamperes D.C. Peak operating current variation is dependent on which portion of the A.C. supply cycle capacitor is charged.

k. The answer-back control relay (or non-contention relay) is connected to the 115 V.A.C. 60 cycle supply circuit of the keyboard and operating current is approximately .035 amperes.

l. The 178345 Modification Kit is a dual purpose modification kit. This kit provides all parts of the answer-back mechanism common to the electrical service assembly (LESU); the kit also contains a motor control feature.

(1) The motor control feature is electrically independent of the answer-back mechanism and is incorporated into the 178345 Modification Kit only to conserve mounting facilities. For this reason the motor control feature comes with the 178345 Modification Kit.

NOTE

The electrical service assembly (LESU) to be used in conjunction with the 178345 Modification Kit must contain a motor control terminal block ("D" terminal block; refer to the appropriate electrical service assembly schematic wiring diagram). Terminals D2 and D6 on this terminal block should be available; no wires should be connected to these terminals before installation of the 178345 Kit.

(2) The basic components of the 178345 Modification Kit are:

- Motor control relay (independent of answer-back feature).
- Subset actuated relay for answer-back operation from Bell System Data-Phone Sub set
- Resistor-diode-capacitor-network to provide delay feature.

m. Theory of Operation (See 4476WD)

(1) The answer-back message is initiated at the called station when the sequential "FIGS" "C" combination is depressed at the originating station. If the answer-back control (non-contention) relay happens to be energized when "FIGS", "C" is received, the "FIGS" stunt box contact will open and de-energize the relay, which was held energized across the A.C. supply line via the "FIGS" contact, via control relay contacts DT4 - DT5. When energized the control relay disables operation of the answer-back.

(2) The "C" stunt box transfer contact will then momentarily leave its normal rest position and charge the 20 MFD capacitor to the polarity shown in 4476WD via the normally closed control relay contacts DT6 - DT7, via the "C" contact, via the 810 OHM resistor - CR1 diode.

(3) The capacitor will then discharge through the answer-back trip magnet via the "C" contact when the "C" contact returns to rest position.

(4) If the typing unit is receiving tape transmission, the "C" stunt box transfer contact will operate during the time when the character immediately following "FIGS" "C" (i.e. LTRS) is being received by the typing unit selector mechanism. (Refer to Timing Chart 1).

(5) The 20 microfarad capacitor will discharge through the answer-back trip magnet (thus energizing the trip magnet) at approximately the end of the 5th pulse of the character immediately following "FIGS" "C". Mechanical time delay then occurs before the answer-back message drum rotates to block the keyboard code bars for transmission of the first answer-back message character.

(6) Therefore, the first message character will be transmitted after the stop pulse of the character immediately following "FIGS" "C" has begun. This means the typing unit has received and selected the character immediately following "FIGS" "C" (i.e. "LTRS" when "FIGS", "C", "LTRS" is received) before answer-back message transmission begins.

(7) The completion of the answer-back trip magnet circuit energizes the answer-back trip magnet and results in the counter-clockwise rotation of the armature and associated stop lever latch, thereby unblocking and releasing the stop lever. Under the bias of a spring attached to the code bar bail latch operating lever, which rests on the left extension of the stop lever, the stop lever rotates counter-clockwise until it comes to rest against the mechanism base plate. Before coming to rest the stop lever moves the blocking lever counter-clockwise, thereby unblocking the drive plate and releasing it to its spring action. The drive plate rotates counter-clockwise to a stop where the attached drive link is in a position to accept the feeding motion from the keyboard code bar bail. As the stop lever continues its counter-clockwise rotation, the code bar bail latch operating lever rotates clockwise, striking the code bar bail latch. The latch rotates clockwise and releases the code bar bail. The code bar bail releases the keyboard code bars and the clutch trip bar which move to the right under spring action. The clutch trip bar thereby trips the signal generator clutch and initiates an operating cycle.

(8) While the code combination transmitted during the first cycle must be a "LETTERS" combination, the code combinations of the succeeding 20 cycles may be any arbitrary character determined by the detachable code blades fastened to the code drum. The code combination on each blade is read by five sensing levers which transfer the code selections to a vertical projection on each of the 5 code bars. Each code combination is thus transmitted in the normal manner by the keyboard signal generator. A spacing condition occurs whenever a code bar is prevented from moving to the right of its associated sensing lever; unrestricted movement of a code bar results in a marking condition. Since the sensing levers must be held away from the code bars in order to prevent their interference during normal keyboard operation, a stop code blade having a "LETTERS" combination must be employed. This necessity results in a "LETTERS" combination for the first character.

(9) Once during each rotation (360°) of the signal generator cam assembly the code bar bail is pulled to the left by a cam eccentric causing it to rotate clockwise. The bail, thereby, resets the keyboard code bars and, with the character generator drive link now in its released position, rotates the drive plate clockwise. This action causes the stepping pawl to step the code drum one position clockwise.

(10) With the stop lever in its released position, the code bar bail latch operating lever also maintains the code bar bail latch in a released position. The signal generator mechanism will cycle continuously until it rotates the code drum one full revolution or 21 characters. The first code blade, which is the stop code blade having a "LETTERS" combination, has an additional projection such that when it is being rotated into the sensing position it contacts the stop lever rotating it clockwise. The left extension of the stop lever rotates the code bar bail latch operating lever counterclockwise which in turn releases the code bar bail latch to the action of its attached spring. Continued rotation of the stop lever brings it in a position where if released to the action of the spring attached to the code bar bail latch operating lever, it will reverse rotation and become latched on the stop lever attached to the trip magnet armature. Such a position is reached when the stop code blade passes its area of contact with the stop lever which is just prior to the complete movement of the stop code blade into the sensing position.

(11) When the code bar bail latch is released to its spring action, it rotates counterclockwise in contact with the code bar bail latch roller until it latches the code bar bail. At this point the blocking lever is also released to its spring action and it rotates counterclockwise until it rests against a projection on the stop lever. In this position the blocking lever holds the drive plate in its extreme clockwise position and the attached drive link is once more unable to follow the feeding motion from the code bar bail. Further operation of the signal generator and character generator is thus prevented. At this point the keyboard is restored to its normal operating condition.

(12) Any character depressed at the originating station will energize the answer-back control (non-contention) relay via the signal generator pulsing or blinding contact. The control relay will then be held energized via the normally closed "FIGS" stunt box contact via control relay contacts DT4 and DT5.

(13) The "FIGS" stunt box function pawl has been modified to engage the "FIGS" function bar at all times. This arrangement converts a normally open momentary operate "FIGS" stunt box contact to a normally closed momentary operate contact and advances the timing of the contact operation in relation to normal stunt box momentary contact operation. This timing advancement insures that the "FIGS" contact will open during the time the signal generator pulsing contact is closed so the pulsing contact will energize the control relay during every cycle of the signal generator. Refer to Timing Chart 1.

(14) The energization of this control relay opens the 20 microfarad capacitor charging circuit through normally closed control relay contacts DT6 and DT7. Therefore, when the "C" transfer contact operates, there can be no discharge through the answer-back trip magnet and the local answer-back is therefore disabled.

(15) The operation of the FIGS stunt box contact, in the control relay locking circuit, may or may not de-energize the control relay depending upon the speed of the operator. However, if the "FIGS" contact does de-energize the control relay, the "C" will again energize the control relay via the signal generator pulsing contact.

(16) Local answer-back operation is obtained by depressing the "HERE IS" key-lever. The "HERE IS" keylever operates a normally open contact mounted on the keyboard directly below the keylever. The closing of this contact places the answer-back trip magnet across the 115 Volt A.C. supply via the CR2 diode, via the 400 ohm series resistor. CR2 provides .070 (average) direct current operation of the trip magnet. Direct current operation through CR2 is required since the 20 MFD capacitor is, in effect, an A.C. shunt across the answer-back trip magnet.

(17) Answer back operation may also be obtained by energization of the 480 subset actuated relay from a Bell System Data-Phone Subset. A 40 volt capacitor charge circuit energizes the subset actuated relay coil; the answer-back trip magnet is then energized across the A.C. supply via the subset actuated relay contacts, via the 400 ohm series resistor, via the CR2 diode.

(18) The answer-back message may be changed by replacing the entire code drum mechanism. See paragraphs 2.d. (1) through (9) for the necessary instructions.

n. The 178343 Modification Kit consists of:

3	4703	Spring	2	152666	Bar, Function
3	72522	Wick	1	153520	Bar, Function
3	90517	Spring	1	154613	Latch
3	94693	Wick	3	157200	Spring
1	152121	Lever, Function	3	157240	Spring
2	152642	Lever, Function	1	152127	Clip
2	152653	Pawl, Function	1	174185	Pawl, Function
2	152660	Plate, Spring	1	178347	Cable Assembly, Function Box

o. The 178344 Modification Kit consists of:

11	2191	Washer, Lock	1	162876	Bar, Retainer
1	3598	Nut	1	162878	Contact Assem. Universal Kybd.
8	7002	Washer, Flat	1	162885	Cam, Segment
2	70314	Washer, Flat	2	162886	Screw
1	121246	Clamp, Cable	1	163852	Keylever Assembly "HERE IS"
2	121473	Stud	1	163979	Lever, Function
3	151630	Screw	1	164129	Answer-Back Parts, Common
2	151631	Screw	1	164457	Keylever Assembly, W-R-U
1	151632	Screw			Upper Case C
1	153538	Screw	1	174184	Plate, Cover
1	154125	Spring	1	178348	Cable Assembly, Keylever
4	155753	Tubing, Insulating			Contact
4	156740	Screw	1	178349	Cable Assembly, Control
2	162875	Bracket			Relay

p. The 178345 Modification Kit consists of:

12	2191	Washer, Lock	4	151660	Screw
4	3598	Nut	2	151692	Screw
3	7002	Washer, Flat	3	151722	Screw
.41 ft.	60022RM	Tubing, Insulating	8	153484	Screw
1	74821	Resistor	3	155753	Tubing, Insulating
1	76461	Washer, Flat	1	162864	Clamp, Cable
1	77902	Screw	1	165522	Diode (420B)
2	90789	Washer, Flat	2	178306	Relay
1	119045	Grommet, Rubber	1	178308	Cable Assembly
2	125010	Washer, Insulating	1	178326	Capacitor
2	150040	Screw	1	178327	Cable w/Connector
4	150995	Spacer	1	178328	Bracket, Mounting
2	151427	Plate, Clamp	1	178330	Plate
1	151630	Screw			

TIMING CHART FOR  
"FIGS", "C" SEQUENTIAL  
ANSWER-BACK

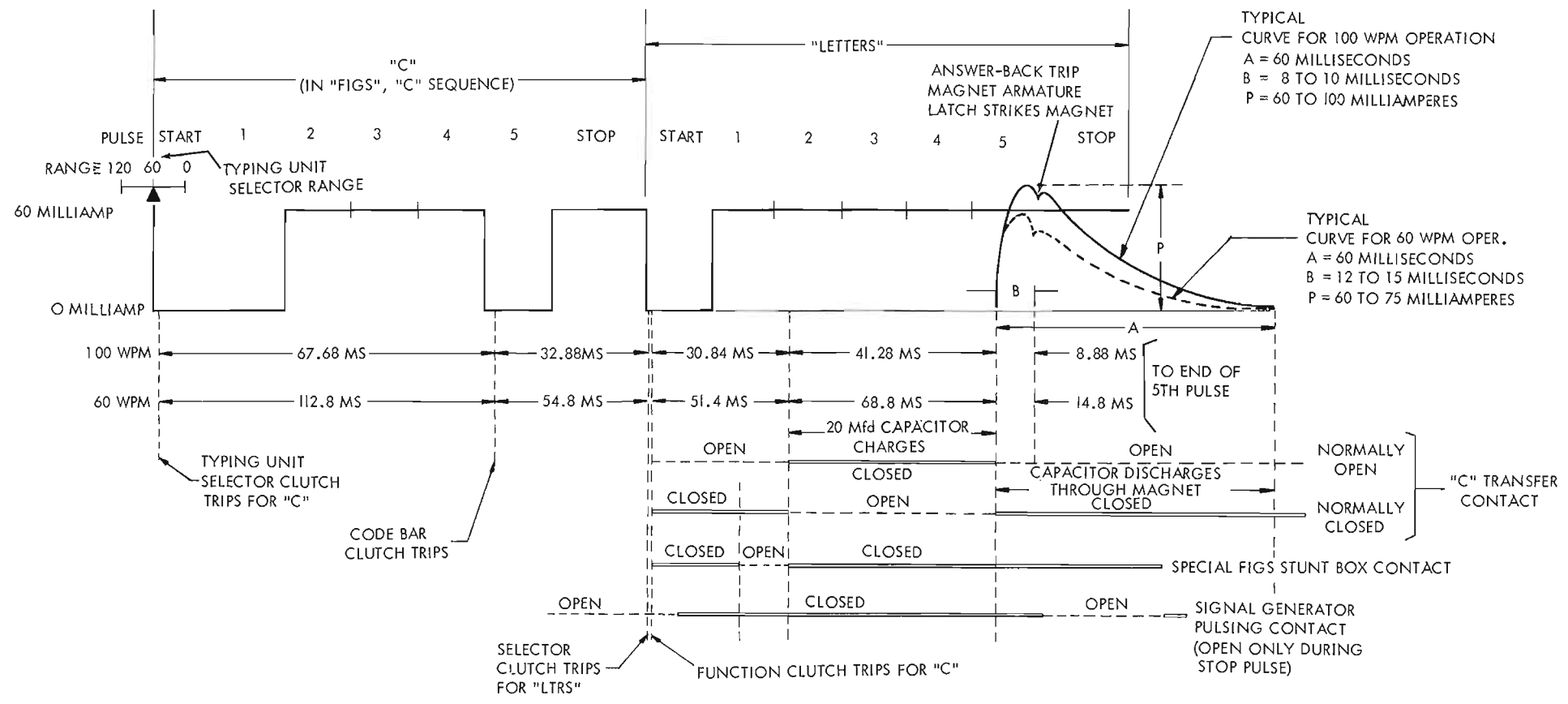

TIMING CHART I

q. For part numbers referred to, other than those in the subject kits, and for parts ordering information see Teletype Model 28 Page Printer Set Parts Bulletin 1149B.

## 2. INSTALLATION

a. Refer to Teletype Model 28 Page Printer Set Bulletin 217B for instructions for removal of major components and assemblies.

### NOTE

References in the text to left or right, up or down, front or rear, apply to the unit in its normal operating position as viewed from the front.

b. The 178343 Modification Kit

(1) Remove the typing unit from the cabinet in accordance with standard practice. Do not replace until so instructed.

(2) Remove the stunt box from the typing unit in accordance with standard practice.

(3) Use the 157240 Spring and 72522 Wick on units having a one stop function clutch; use the 157200 Spring and 94693 Wick on units having a two stop function clutch.

(4) Install the following parts in slot No. 32.

<u>Part No.</u>	<u>Description</u>
174185	Pawl, Function
157240	Spring
72522	Wick
157200	Spring
94693	Wick
152666	Bar, Function "Figs"
4703	Spring
152642	Lever, Function
90517	Spring
152660	Plate, Spring

(5) Install the following parts in slot No. 33

<u>Part No.</u>	<u>Description</u>
152653	Pawl, Function
157240	Spring
72522	Wick



157200	Spring
94693	Wick
152666	Bar, Function "Figs"
4703	Spring
152121	Lever, Function
90517	Spring
154613	Latch

(6) Install the following parts in slot No. 34:

<u>Part No.</u>	<u>Description</u>
152653	Pawl, Function
157240	Spring
72522	Wick
157200	Spring
94693	Wick
153520	Bar, Function "C"
4703	Spring
152642	Lever, Function
90517	Spring
152660	Plate, Spring

(7) If the printer stunt box is equipped with the blank-blank keyboard lock sequence parts, and if it is desired to disable this feature, install the 152127 Clip. Position the clip with its closed end under the function pawl in slot No. 35 so that it lifts the pawl out of engagement with the function bar when the hooks at the open end of the clip are placed over the 150544 Handle.

(8) Install 172502 and 172570 Switch Assemblies across stunt box slots 29,30,31, 32 and 33,34,35,36 respectively. When stunt box slots 29 to 32 are not available, use slots 23 to 26 and modify cable to fit.

(9) Replace the stunt box in the printer. Do not replace the printer. Make the Figs contact adjustment at this time (Refer to Figure 18). Route the switch cable along the 150544 Handle to the connector side of the printer.

(10) When the Figs contact adjustment has been made route the switch cable along the 150544 Handle.

(11) Tie the cable to the handle at appropriate positions to the connector side of the printer.

c. The 178344 Modification Kit

(1) Remove the keyboard from the cabinet in accordance with standard practice.

- (2) Remove the keyboard hood in accordance with standard practice.
- (3) Remove the keylever guide plate in accordance with standard practice.
- (4) Remove and discard the plastic plug and speed nut from the keytop hole, sixth from the left in the top row.
- (5) Maneuver the 163979 Function Lever into the 21st slot of the 154070 Code Lever Guide until it is fully seated on the 154016 Code Bar Lever Shaft.
- (6) Install a 154125 Spring on the 163979 Function Lever and 154070 Code Lever Guide.
- (7) Replace the keylever guide plate on the keyboard in accordance with standard practice. Re-adjust the space bar bail pivot. (Refer to Bulletin 217B). Do not replace the keyboard hood until so instructed.
- (8) Remove the lock ball retainer clamp from its present position in the center of the 154175 Lock Ball Channel and install it in the position immediately to the right of center.
- (9) Install the 163852 Keylever Assembly (Here Is) in the keytop guide hole previously unplugged, snapping onto the 163979 Function Lever previously installed in this position. See Figure 1.
- (10) Remove the existing "C" keylever assembly and replace with the 164457 W-R-U upper case "C" keylever assembly.
- (11) Remove the two screws, lockwashers and flat washers (one at a time on each side), holding the lockball channel. Install two 121473 Studs with the lock washers and flat washers just removed. (See Figure 1.)
- (12) Check and if necessary, make the lock ball channel adjustment.
- (13) Place a 162875 Bracket on top of each 121473 Stud and assemble them only friction tight with two 156740 Screws, 2191 Lock Washers and 7002 Flat Washers. (See Figure 1.)
- (14) Install the 162876 Retainer Bar on top of the 162875 Brackets and assemble it only friction tight with two 156740 Screws, 2191 Lock Washers and 7002 Flat Washers. (See Figure 1.)

#### NOTE

Use caution when handling the 162873 Contact to be installed according to the next paragraph.

(15) Install the 162873 Contact Assembly (part of 178348 Cable Assembly) on the 162876 Retainer Bar and assemble it only friction tight with the 162874 Clamp Plate, 1178 Screw, 71073 Flat Washer, 93117 Lock Washer and 112627 Nut. Move the contact assembly along the retainer bar until it is beneath the 153979 Function Lever previously installed. Tighten the assembly. Route the white-brown (W-BR) and slate (S) wires through the keyboard base to the signal generator. Tie the cable assembly near the end of the retainer bar on both sides of the contact assembly (See Figure 1.)

(16) Install the resistor-suppressor assembly (part of 178348 Cable Assembly) on the 154175 Lock Ball Channel by means of the mounting hole on the right side of the channel. Use a 151632 Screw, 2191 Lock Washer, 7002 Flat Washer and 3598 Nut to secure the assembly (See Figure 2).

(17) Route the purple (P) and slate (S) wires through the keyboard to the motor terminal block. Route the white-slate (W-S), green (G) and white-brown (W-BR) wires with terminals as far as possible toward the rear of the keyboard for later connection to the 178349 Control Relay Assembly (See 4477WD).

(18) Route the green (G) and white-green (W-G) wires toward the rear of the keyboard for later connection to the answer-back trip magnet. (See paragraph (51)).

(19) To facilitate installation of the 178349 Control Relay Assembly in the right rear corner of the keyboard base, connect the white-slate (W-S) green and white-brown (W-BR) wires from the 178348 Keylever Contact Cable Assembly to the control relay terminal block. (See 4477WD).

(20) Route the purple (P) and slate (S) wires from the control relay assembly to the motor terminal block.

(21) Route the two six point connectors through the top of the keyboard. (See Figure 3).

(22) Install the 174184 Control Relay Cover Plate in the following manner. Place the 121246 Cable Clamp over the two cables and insert the 153538 Screw, 2191 Lock Washer and 7002 Flat Washer through the cable clamp. Then place the 70314 Flat Washer beneath the cable clamp and secure the clamp and cover plate to the relay mounting bracket. (The entire control relay assembly is secured at the rear of the keyboard by the 70314 Flat Washer which overlaps onto the keyboard base.)

(23) Secure the other end of the cover plate with a 151630 Screw, 2191 Lock Washer and 70314 Flat Washer.

(24) Connect the two purple (P) wires, previously routed, to terminal one of the motor terminal block. (See 4477WD).

(25) Connect the two slate (S) wires, previously routed, to terminal two of the motor terminal block. (See 4477WD).

(26) Remove the signal generator from the keyboard in accordance with standard practice.

(27) Remove and discard the two 151737 Screws which secure the cam sleeve assembly to the clutch cam disk. Retain the lockwashers.

(28) Install the 162885 Cam Segment with the two 162886 Screws and the two lockwashers previously removed. Refer to Figure 4. The 162885 Cam Segment and 162886 Mounting Screws can be maneuvered into place without removing any parts from the signal generator assembly.

(29) Place two 155753 Plastic Tubing Insulators over the bare wires of the 178348 Keylever Cable Assembly previously routed to the signal generator. Solder the slate (S) wire to the contact spring and solder the white-brown (W-BR) wire to the contact stiffener of the 162878 Pulsing Contact. (Figure 16 and Paragraph (15)).

(30) Install the 162878 Universal Pulsing or blinding contact assembly on the 154009 Signal Generator Front Plate as shown in Figure 6 using two 151631 Screws, two 2191 Lock Washers and two 7002 Flat Washers. (See Figure 4).

(31) Replace the 154017 Eccentric Stud with the 173096 Eccentric Stud. To do so it will be necessary to loosen the signal generator rear plate and code bar bail so the eccentric studs may be maneuvered into and out of the code bar bail. (See Figure 5).

(32) The signal generator rear plate may be loosened by removing the nuts and lockwashers which fasten the plate to the:

151207 code bar bail stud  
154018 locking bail post  
154014 guide post

Also remove the screw which fastens the signal generator rear plate to the generator frame by means of an "L" bracket.

Remove the retaining ring from the rear of the 151207 Code Bar Bail Stud to loosen the code bar bail. Be sure to replace all parts after the 173096 Eccentric has been installed.

(33) Unhook the 154191 Code Bar Bail Latch Spring from the 154089 Spring Post. Remove the 154079 Stud and the 158268 Code Bar Bail Latch, 154191 Spring, 115122 Felt Washer and 119651 Retaining Ring from the signal generator 154102 Rear Plate. Remove the latch, spring, felt washer and retaining ring from the stud. Discard the stud, re-install the 158268 Latch, its spring and felt washer on the 164138 Stud. Also place the 173029 Latch Operating Lever on the stud so that its hub is adjacent to the latch with its right side projection overlapping the latch. Retain the parts on the stud with the original 119651 Retaining Ring. Re-assemble the 164138 Stud and its parts on the signal generator rear plate by maneuvering the parts up from the bottom so that the 173029 Lever extends through the cutout

in the code bar bail. Fasten the stud with the original lock washer and nut. (Refer to Figure 5).

(34) Unhook the 154215 Code Bar Bail Spring from the 154089 Spring Post. Remove the 154089 Spring Post from the 154102 Signal Generator Rear Plate and replace it with the 173028 Spring Post. Replace the 154215 Code Bar Bail Spring and 154191 Code Bar Bail Latch Spring on the 173028 Post. Place the 76422 Latch Operating Lever Spring on the 173029 Lever only. The 76422 Spring should be replaced on the 173028 Post after the character generator mechanism has been installed on the keyboard. (Refer to Figure 5).

(35) Install the 150089 Screw and 151880 Lock Nut in the tapped hole located on the right side of the 173029 Latch operating lever. (Refer to Figure 5).

#### NOTE

Make the 162878 Pulsing Contact adjustment at this time. (Figure 16 and Paragraph 3.d.(1) to (3)).

(36) Replace the signal generator on the keyboard in accordance with standard practice. Check, and if necessary, make the code bar and code lever clearance, the code bar bail, the code bar bail and non-repeat lever clearance, the universal bail latch lever, the universal bail extension, the ball wedgelock and ball track clearance and the lock ball end play adjustment. (Refer to the Model 28 Adjustment Bulletin 217B).

#### NOTE

The code bar bail clearance adjustment of some to .006 inch must be refined to .004 inch to .006 inch.

(37) Remove and retain the 151739 Keytop Arrangement Identification Screw and its 2191 Lock Washer from the keyboard.

(38) Install the 164142 Mounting Bracket on the keyboard so that it is offset towards the top. Use the two mounting holes located on the left side of the 156574 Spring Post on the 154179 Universal Bail. Fasten the bracket with a 151722 Screw and 2191 Lock Washer and also the previously removed 151739 Identification Screw and 2191 Lock Washer. (Refer to Figure 6).

#### NOTE

Paragraphs 39 through 50 and Paragraph 54, pertain to the assembly of the 179865 Basic Answer-Back Mechanism Assembly. This mechanism is part of the 164129 Common Answer-Back Parts. The 179865 Basic Answer-Back Mechanism Assembly is shipped assembled and Paragraphs 39 through 50 and 54 apply only if a complete assembly is undertaken.

(39) The 164143 Mounting Plate for the character generator has all of its projection extending upwards with guide slots on its left side, and the trip magnet mounting projection on its right side. It is secured to the keyboard by means of two elongated slots at the front and by one such slot at the rear. Mount a 164144 Side Plate at right angles to the top rear of the 164143 Plate by means of two mounting holes in the projections at the bottom of the side plate. Assemble the 164144 Side Plate only friction tight with two 151692 Screws and 2191 Lock Washers so that its bottom center projection is located in the cut-out of the 164143 Plate. (Refer to Figure 6).

(40) Place the 164146 Stop Lever on the 164145 Levers Pivot so that with the grooves in the pivot offset towards the rear, the lever rests on the rear 5/16" dia. and front 7/32" dia. portion of the pivot. The ear extension of the lever should then be at the front left side while the lever encircles the pivot on the right side. Place the 164148 Spacer on the 164145 Pivot in front of the 164146 Stop Lever. Insert the 164149 Blocking Lever in the small groove of the 164145 Pivot so that the 164148 Spacer is retained between the stop lever and blocking lever. The blocking lever should then rest against the left side of the upper ear extension on the stop lever. Hold the two levers together by installing the 42661 Spring in the spring eye of the 164149 Blocking Lever and the spring extension of the 164146 Stop Lever. (Refer to Figure 6).

(41) Place the rear projection of the 164145 Levers Pivot in the 1/8" hole near the bottom of the 164144 Side Plate mounted on the 164143 Plate. Place another 164144 Side Plate towards the front of the 164143 Plate so that it engages the front projection of the 164145 Levers Pivot and is positioned similarly to the rear 164144 Side Plate already installed. Assemble the front side plate only friction tight with two 151692 Screws and 2191 Lock Washers. (Refer to Figure 6).

(42) Install the 164150 Spring Bracket between the two 164144 Side Plates at the top right side so that the projections on the spring bracket engage the slots in the side plates. The contact point between the 164146 Stop Lever and 164144 Blocking Lever should be on the left side of the 164150 Spring Bracket. Assemble the 164150 Bracket only friction tight to the side plates with two 151152 Screws and 3640 Lock Washers. (Refer to Figure 6).

(43) Firmly press the two outer sides of two 164144 Side Plates towards each other so that each side plate bears against the front projection on the 164143 Mounting Plate, the 164145 Levers Pivot and the 164150 Spring Bracket; then securely fasten the six screws which mount the two side plates and the spring bracket. (Refer to Figure 6).

(44) Install five 151397 Sensing Lever Springs on the 164150 Spring Bracket in the five spring mounting holes which are located towards the front side plate. Install the 151715 Detent Lever Spring on the 164150 Spring Bracket in the spring mounting hole adjacent to the rear side plate. (Refer to Figure 6).

(45) Install five 164154 Sensing Levers on the 164145 Levers Pivot in the five grooves which are towards the front side plate. The left extension on each sensing lever should engage its corresponding guide slot on the left side of the 164143 Mounting

Plate. Hook the five 151397 Sensing Lever Springs on the spring grooves of the five sensing levers. (Refer to Figure 6.)

(46) Install the 164151 Detent Lever on the 164145 Levers Pivot in the groove near the rear side plate. The detent roller should be towards the top. Hook the 151715 Detent Lever Spring on the spring groove of the detent lever. (Refer to Figure 6).

(47) Install the 164155 Magnet Yoke on the right side extension of the 164143 Mounting Plate. The spring post should be towards the front with the mounting holes toward the rear. Fasten the yoke with two 153537 Screws, 2191 Lock Washers and 7002 Flat Washers. (Refer to Figure 6).

(48) Install a 119649 Retaining Ring on the 164157 Shaft in the groove located approximately 1/16" from one end. Install the 164156 Armature with its two projections extending upward between the two lower projections at the bottom of the 164155 Magnet Yoke. Retain the armature by means of the shaft inserted from the rear through the two holes in both the yoke and armature. Install another 119649 Retaining Ring on the 164157 Shaft so that the rear projections on both the armature and yoke are retained between the two rings. (Refer to Figure 6).

(49) Install the 164158 Latch by means of its two mounting slots on the bottom of the 164156 Armature so that the latch extends in front of the yoke and to the left of the latching surface on the 164146 Stop Lever. Fasten the latch to the armature by means of two 151737 Screws, 110743 Lock Washers and 87398 Flat Washers. Install the 42661 Spring between the spring groove on the latch and the spring post on the yoke. (Refer to Figure 6).

(50) Install the 194M Magnet Coil on the 164155 Magnet Yoke between its upper projection and the 164156 Armature. The magnet coil terminals should extend upward on the right side of the yoke when properly mounted. Fasten the coil with a 153799 Screw and 3640 Lock Washer. (Refer to Figure 6).

(51) Solder the white-green (W-G) and (G) wires to the magnet as indicated in 4477WD. Use 155753 Plastic Tubing Insulators. Tie the wires to the rear of the magnet yoke making certain that they do not interfere with any moving parts on the answer-back mechanism or keyboard. (Refer to Paragraph (18)).

(52) Place the 164162 "O" Ring in the groove on the rim of the 164161 Message Drum which is furthest from the slot in the center portion of the drum. Install the 164163 Stop Blade in any slot position in the drum by first inserting the blade under the "O" ring and then rotating the blade toward the center of the drum until it is fully seated. (Refer to Figure 7).

(53) Code the drum in the following manner: (Refer to Figure 7).

(a) Almost any answer-back message desired may be selected which does not contain more than 21 characters including spaces. However, the coding of the message

drum always begins with a LETTERS (stop blade) and is normally followed by CARRIAGE RETURN and LINE FEED; The coding also normally ends with CARRIAGE RETURN and LINE FEED. This arrangement insures that the message will appear at the beginning of a line on the distant station and that over-printing of the message will not occur. Transmission of the LETTERS code combination at the beginning of the message also returns all stations in the circuit to the unshift position. Since 5 of the 21 available characters are thus used to perform these functions, only 16 are available for the message itself. This procedure may be altered to suit a particular application of the answer-back mechanism.

(b) Code the drum in a counter-clockwise direction beginning with the No. 2 164164 Code Blade adjacent to the 164163 Stop Blade. Each 164164 Code Blade is provided with removable tines for all levels of the transmission code (1,2,3,4,5). A "O" code level tine has been provided on each blade for future usage on six level key-boards and may be currently disregared. A blade is coded by breaking off the unwanted tines at the scored line at the base of each tine. Figure 7 indicates which tines are to be removed for a particular character. To prevent distortion of a code blade, each blade should be held securely near the score mark of the tine to be removed. Although twenty code blades are sufficient to completely code the drum, twenty-five such blades have been provided to allow for possible errors in coding. Since each slot position in the drum must be occupied by a code blade, the unused characters under the twenty permitted for customer use shall be coded either for LETTERS or BLANKS or some such tolerable character.

(c) Install each coded 164164 Blade in the proper slot position in the drum by first inserting the blade under the "O" ring and then rotating the blade toward the center of the drum until it is fully seated. After filling the code drum, encircle the code blades by placing another 164162 "O" Ring in the groove on the opposite rim of the 164161 Drum.

(54) Install the 164168 Stepping Pawl on the 164165 Drive Plate by means of the 164169 Eccentric Stud, 150411 Flat Washer, 3640 Lock Washer and 151880 Nut. Install the 42661 Spring between the pawl and drive plate by means of the spring eye in each part. (Refer to Figure 8).

(55) Apply a thin film of grease on the shaft of the 164165 Drive Plate. Install the message drum complete with coded blades and "O" rings on the shaft of the drive plate. Depress the stepping pawl extension to raise the pawl sufficiently so that the drum bears against the hub on the drive plate and the pawl fully engages the projections on the code blades. Hold the assembled parts approximately as indicated in Figure 8 by means of the thumb and first two fingers of the left hand. Slide the drive plate shaft downward along the left sides of the curved slots in the 164144 Side Plates until the drum assembly is fully seated as indicated.

(56) To facilitate the adjustment of the character generator mechanism, the following adjustments should be made before the mechanism is installed on the keyboard:



Magnet Yoke (Figure 9)  
Stop Lever Latch (Figure 10)

(57) After making the magnet yoke and stop lever latch adjustments, remove the message drum by reversing the procedure used in its installation. The answer-back mechanism may now be installed on the keyboard. With the parts assembled as indicated in Figure 6, maneuver the character generator mechanism so that the left side projection of the 164146 Stop Lever is under the 150089 Screw fastened to the 173029 Latch Operating Lever and the front portion of the 164143 Mounting Plate is resting on the keyboard base while the rear portion of the 164163 Plate is resting on the 164142 Mounting Bracket. Assemble the 164143 Mounting Plate only friction tight to the keyboard and bracket by means of 153537 Screws, 2191 Lock Washer and 7002 Washers placed in the rear and right front mounting slots of the plate. (See Figure 6).

(58) To facilitate the adjustment of the answer-back mechanism, the following adjustment should be made when the mechanism is being installed on the keyboard after the signal generator has been replaced.

Mounting Plate (Figure 11)

(59) Assemble the 173095 and 164160 Drive Links together as indicated on Figure 8. Use two 151152 Screws, 3640 Lock Washers and 125011 Flat Washers to assemble the parts only friction tight. Install the assembled drive links on the appropriate shoulder of the 173096 Code Bar Reset Bail Eccentric Stud. Rest the 164160 Link along the rear side of the front 164144 Side Plate of the answer-back mechanism. Install the 90573 Spring in the spring eye of the 164160 Link.

(60) Install the drive plate assembly without the message drum on the character generator mechanism as previously described. Hook the 90573 Spring on the 164169 Eccentric Stud making certain that the slot in the 164160 Drive Link engages the stud on the drive plate.

(61) Make the following answer-back generator adjustment at this time:

Drive Link (Figure 12)

(62) Unhook the 90573 Drive Link Spring from the 164169 Eccentric Stud. Disengage the slot in the 164160 Drive Link from the stud on the 164165 Drive Plate. Remove the drive plate assembly from the character generator mechanism. Install the message drum on the drive plate shaft and install the drum and drive plate assembly on the mechanism as previously described. Re-hook the 90573 Spring on the 164169 Stud. Make certain that the slot in the 164160 Drive Link engages the stud on the drive plate; if necessary, turn the drive plate with its attached stepping pawl held out of the engagement with the code blades so that the parts are properly aligned.

(63) Make certain that the 164146 Stop Lever is latched on the 164153 Latch. Install the 76422 Spring for the code bar bail latch operating lever on the 173028 Post.

(64) Make the following final answer-back generator adjustments:

Stepping Pawl (Figure 13)

Latch Operating Lever Adjusting Screw (Figure 14)

(65) Again make certain that the 164146 Stop Lever is latched on the 164158 Latch and also that the signal generator clutch is disengaged. Turn the message code drum clockwise until it is in its fully detented position and the 164154 Sensing Levers are resting on the 164163 Stop Blade which is just below the pawl shaped surface on the upright projection of the 164146 Stop Lever. (Refer to Figure 3).

(66) Lubricate the answer-back mechanism in accordance with Paragraph 3.

(67) Make the "HERE IS" keylever switch adjustment in accordance with Paragraph 3.

(68) Replace the keyboard hood, keyboard and typing unit in accordance with standard practice.

d. Answer-Back Message Code Drum may be changed by replacing the entire code drum mechanism as outlined in (1) through (9) below (see Figure 3).

(1) Unhook the 90573 Drive Link Spring from the 164169 Eccentric Stud.

(2) Disengage the slot in the 164160 Drive Link from the stud on the 164165 Drive Plate.

(3) Grasp the code drum with the thumb and first two fingers of the left hand and while pushing the entire assembly to the right, lift the drum and its drive plate out of the mechanism. Slide the drum assembly from the shaft of the drive plate and replace it with the one desired.

(4) Depress the stepping pawl extension to raise the pawl sufficiently so that the new drum bears against the hub on the drive plate and the pawl fully engages the projections on the code blades.

(5) Hold the assembled parts as shown on Figure 8 and re-insert them in the answer-back mechanism by reversing the disassembly instructions.

(6) Hook the 90573 Spring on the 164169 Eccentric Stud.

(7) Make certain that the slot in the 164160 Drive Link engages the stud on the drive plate; if necessary, turn the drive plate with its attached stepping pawl held out of engagement with the code blades so that the parts are properly aligned.

(8) If the code bar bail latch has been released during the above procedure, relatch the 164146 Stop Lever on the 164158 Armature Latch and turn the motor hand-wheel

or signal generator shaft until the signal generator clutch is disengaged.

(9) Turn the code drum clockwise until in its fully detented position the sensing levers are resting on the 164163 Stop Blade which is just below the pawl shaped surface of the upright projection of the 164146 Stop Lever.

e. The 178345 Modification Kit (shipped assembled).

(1) Remove the two electrical service assembly mounting studs for access to the service assembly. Remove and discard the 151441 Blank Plate that is mounted on the electrical service unit next to the cover plate that contains the fuse socket and convenience receptacle. Install the 178345 Modification Kit in place of the 151441 Blank Plate. (See 4481 WD). Route and connect the 178308 Cable Assembly and 178327 Cable Assembly to the appropriate service assembly terminal blocks as shown in 4481 WD.

(2) Replace the electrical service assembly, keyboard hood, keyboard and typing unit in accordance with standard practice.

(3) Connect the two keyboard connectors to the associated typing unit connector and the electrical service unit connector. Check cables for possible interference. Tie the cables to the electrical service unit end posts to insure that the cables are held away from the motor.

### 3. ADJUSTMENTS AND LUBRICATION

a. For standard adjustments and standard lubrication procedure refer to Teletype Model 28 Page Printer Set Bulletin 217B (Bell System refer to standardized information).

b. Make the subject kit adjustments and lubrication as given in the text and referring to the appropriate attached figures.

c. Make the following "HERE IS" keylever adjustments before the keyboard hood is reinstalled on the keyboard. (See Figure 1).

#### (1) Keylever Switch Position - Preliminary

##### Requirement

The centerline of the insulator on the center contact spring should be aligned with the centerline of the 163979 Function Lever.

##### To Adjust

Loosen the 151830 Nut which fastens the switch assembly to the 162876 Retainer Bar and position the switch. Tighten the nut.

#### (2) Keylever Switch Horizontal Position

Requirement

The centerline of the insulator on the center contact spring should be aligned with the centerline of the lowermost portion of the 163979 Function Lever.

To Adjust

Loosen the two 156740 Screws which fasten the 162876 Retainer Bar to the two 162875 Brackets and position the retainer bar. Tighten the screws.

(3) Keylever Switch Vertical Position

Requirement

With the keylever in the unoperated position there should be .015" to .025" clearance between the center and lower contacts.

To Adjust

Bend upper contact spring to meet the requirement.

Requirement

Pull up 163979 Function Lever with a spring hook at rear of code bar bracket alongside of upstop bar until the lobe on the front of the 163979 Function Lever touches the insulator of the center contact; there should be at least .010" between the center and lower contacts.

Center and lower contacts shall close with some over-travel when keylever is depressed with 16 oz. pressure using a 32 oz. spring scale.

To Adjust

Loosen the two 156740 Screws which fasten the two 162875 brackets on the two 121473 Studs and position the complete mounting assembly.

d. Make the 162878 Pulsing Contact adjustment referring to Figure 15, 16 and 17 (Note on page 12).

(1) With the pulsing contact installed on the signal generator, there should be at least .010" clearance between the contact guard and the rocker bail assembly. (Refer to Figure 16.) To adjust - loosen the two contact assembly mounting screws and position the contact assembly.

(2) Rotate the main shaft until the lower extension of the cam follower arm rests on the high part of the cam. The clutch should now be in a latched position. There should be

.015 to .025" clearance between the contact points. (Refer to Figure 15). To adjust - loosen the two mounting bracket screws, leaving the bottom screws friction tight and position the mounting bracket to meet this requirement. Tighten the mounting screws.

(3) There shall be at least .015" clearance between the lower extension of the cam follower arm and the inside surface of the clutch disk. To adjust - loosen the two mounting screws and position the cam follower hinge. (Refer to Figure 16).

#### NOTE

When checking this adjustment, rotate the main shaft several times and check the entire cycle. Make sure the lower extension of the follower arm does not come in contact with the adjusting disk mounting screws.

\*

\*

\*

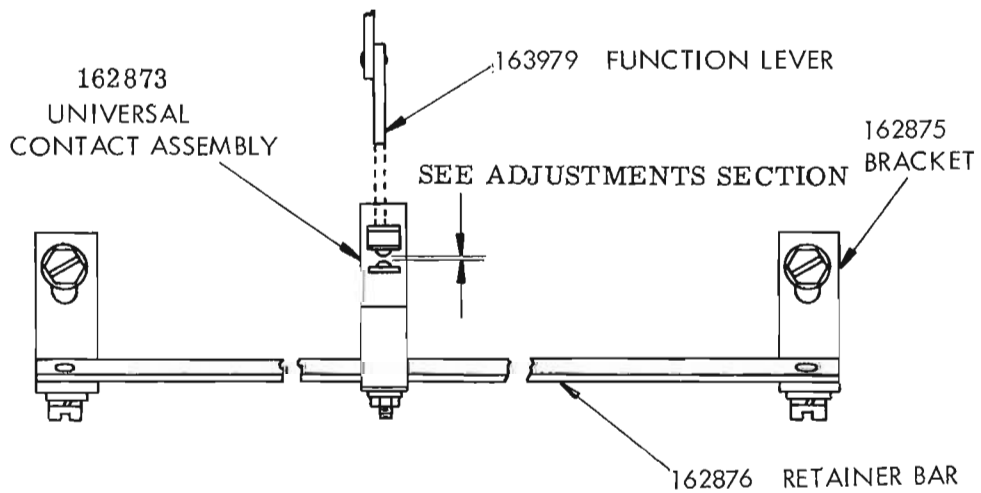
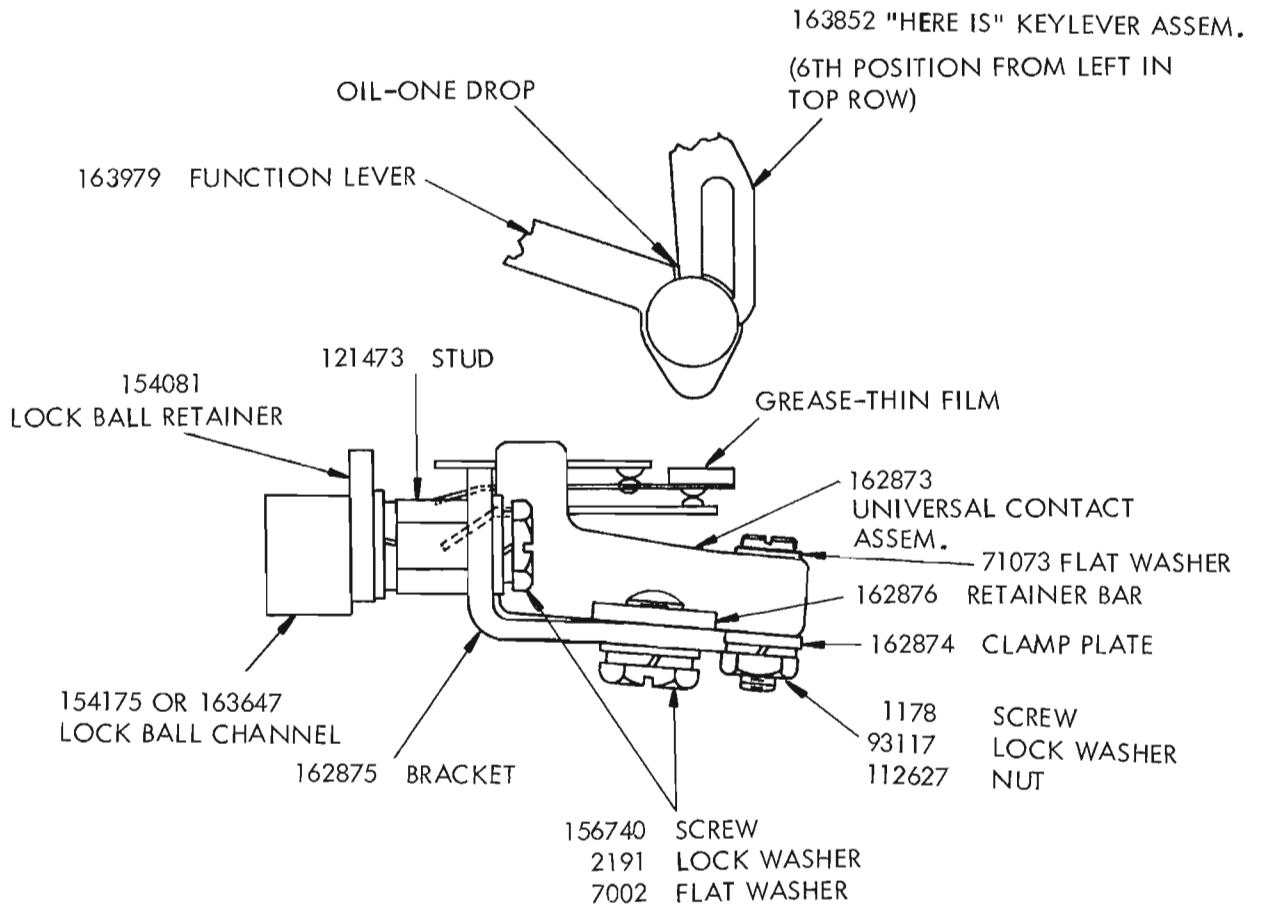

FIGURE 1.

RIGHT SIDE OF CHANNEL

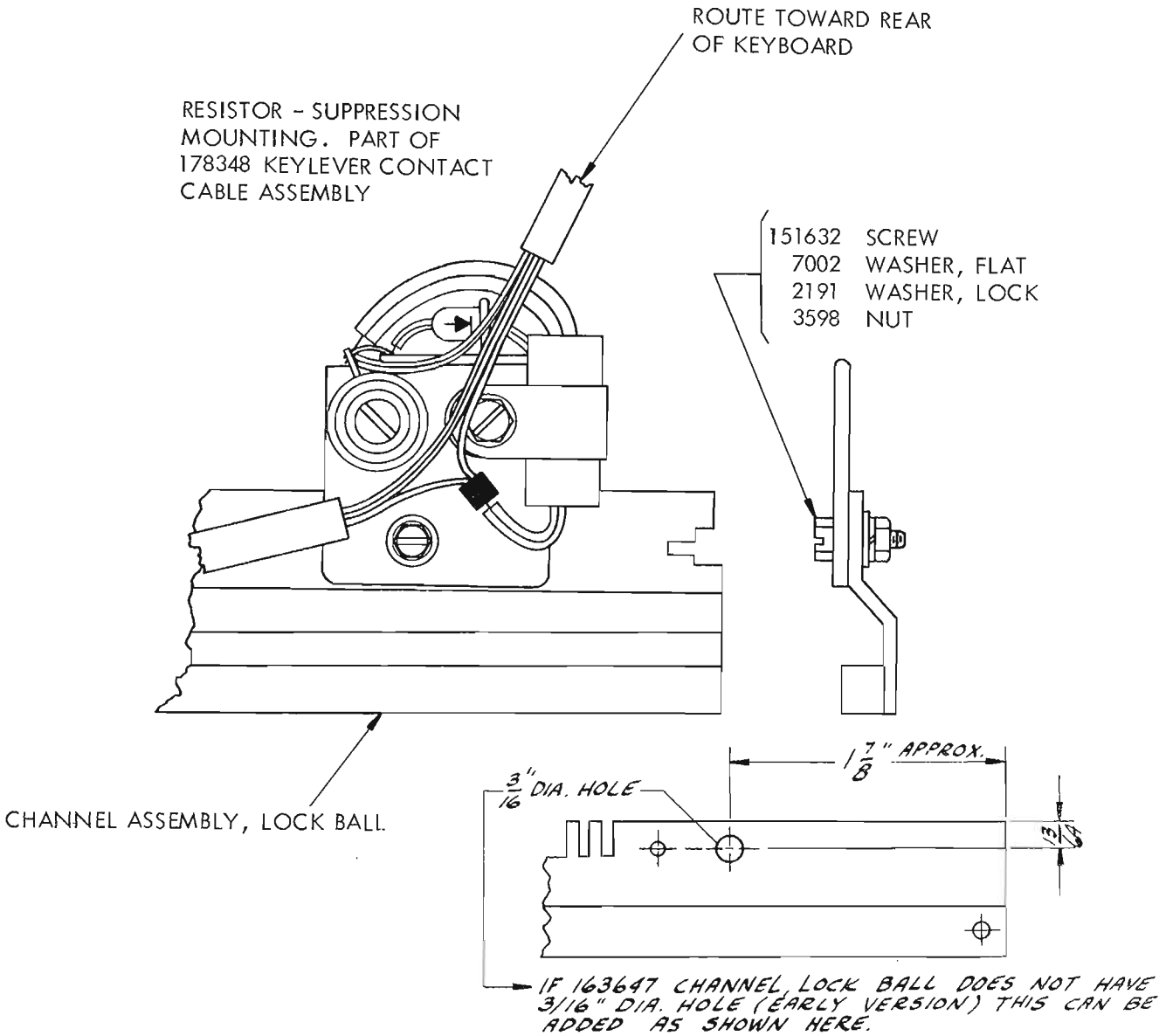
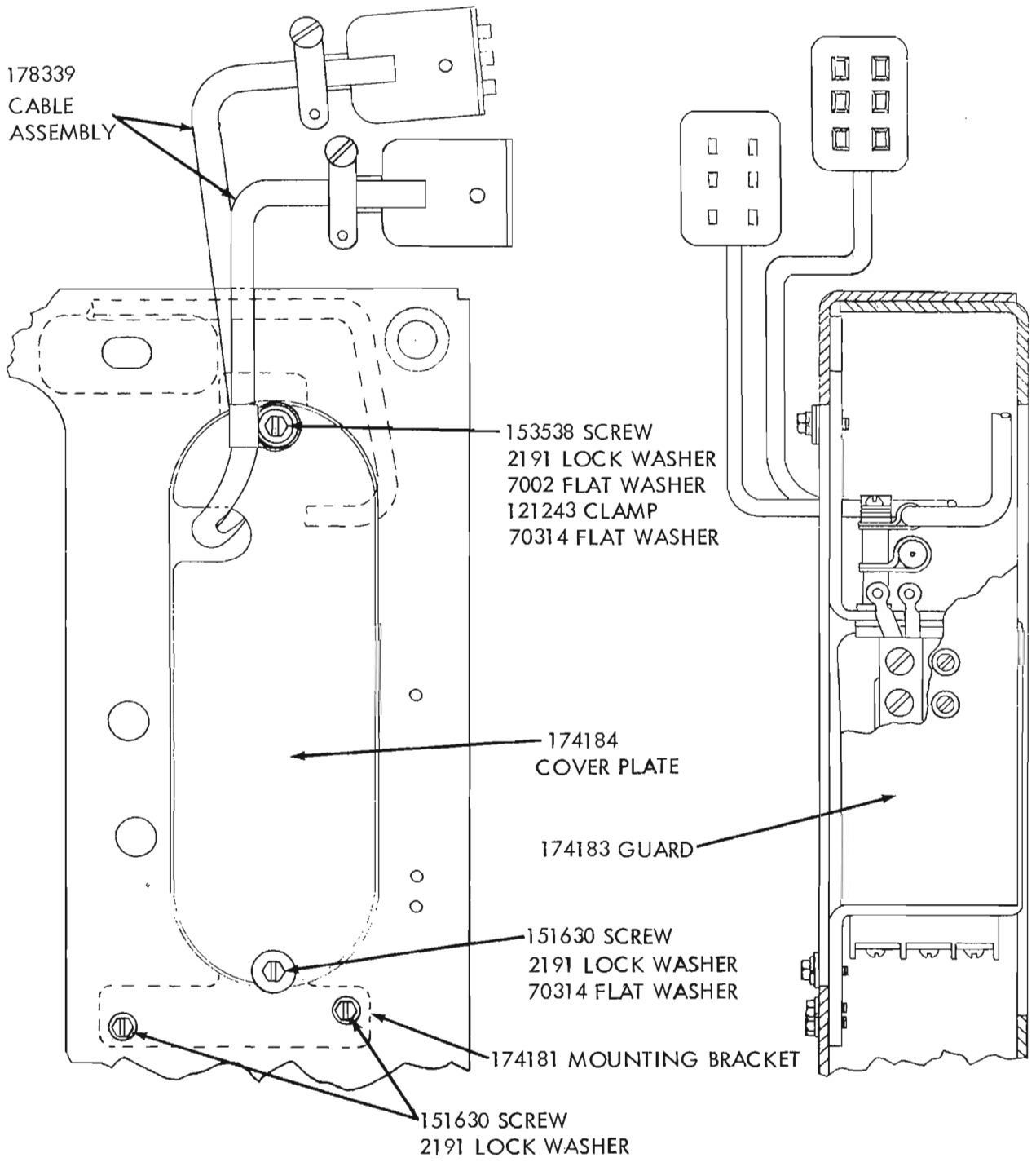

FIGURE 2.



KEYBOARD BASE  
(VIEW OF RIGHT REAR SHOWING PARTIAL  
VIEW OF 178399 ASSEMBLY)

FIGURE 3.



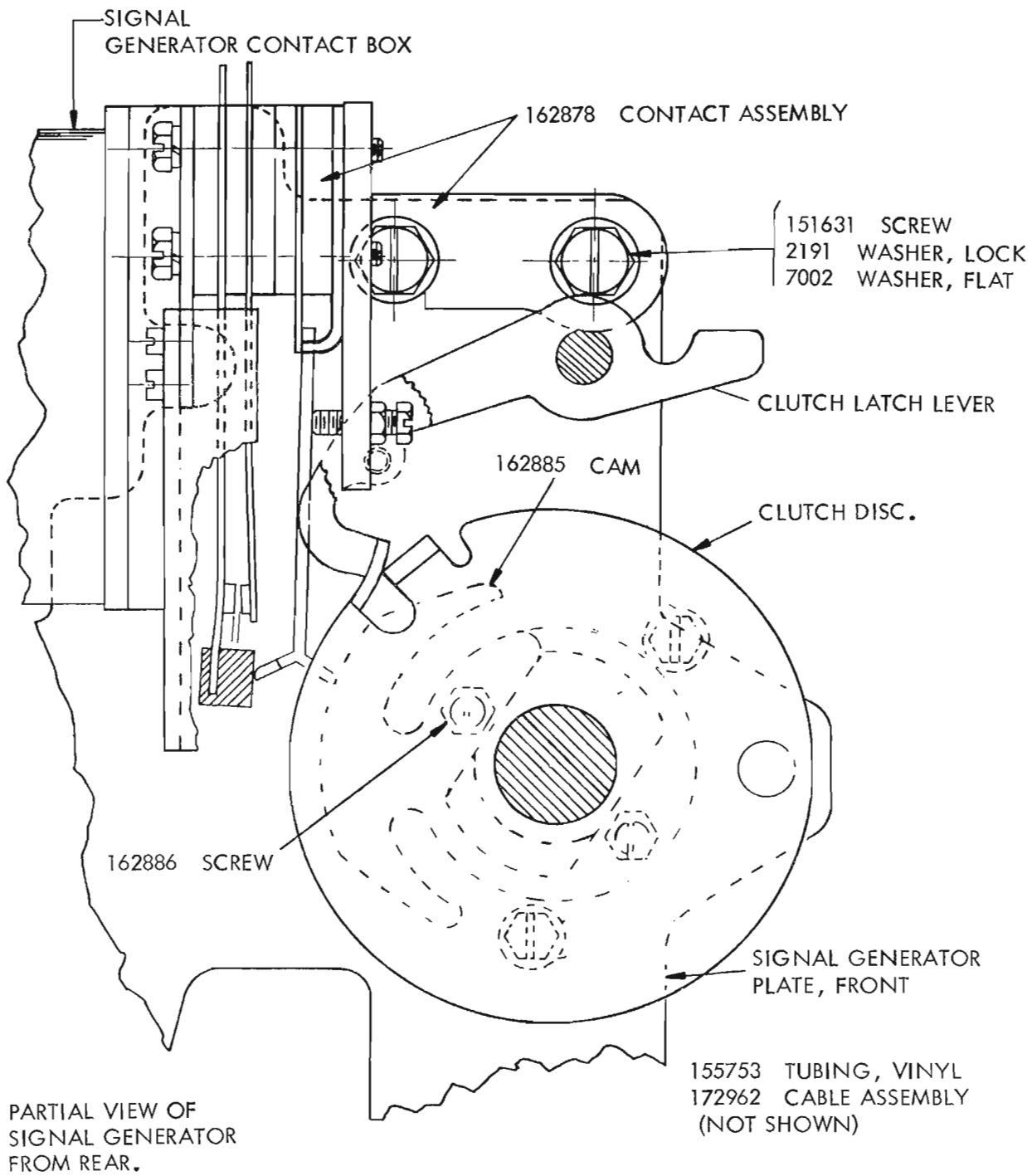

FIGURE 4.

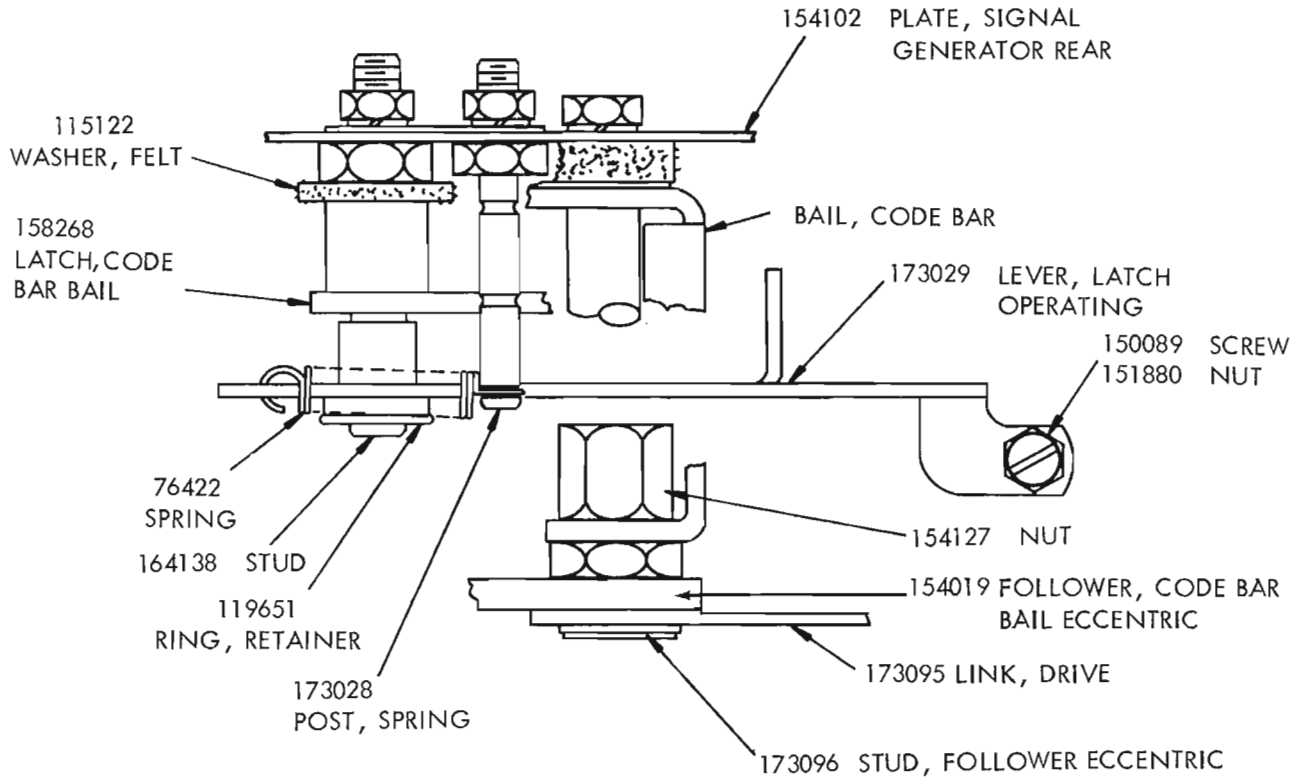

FIGURE 5.

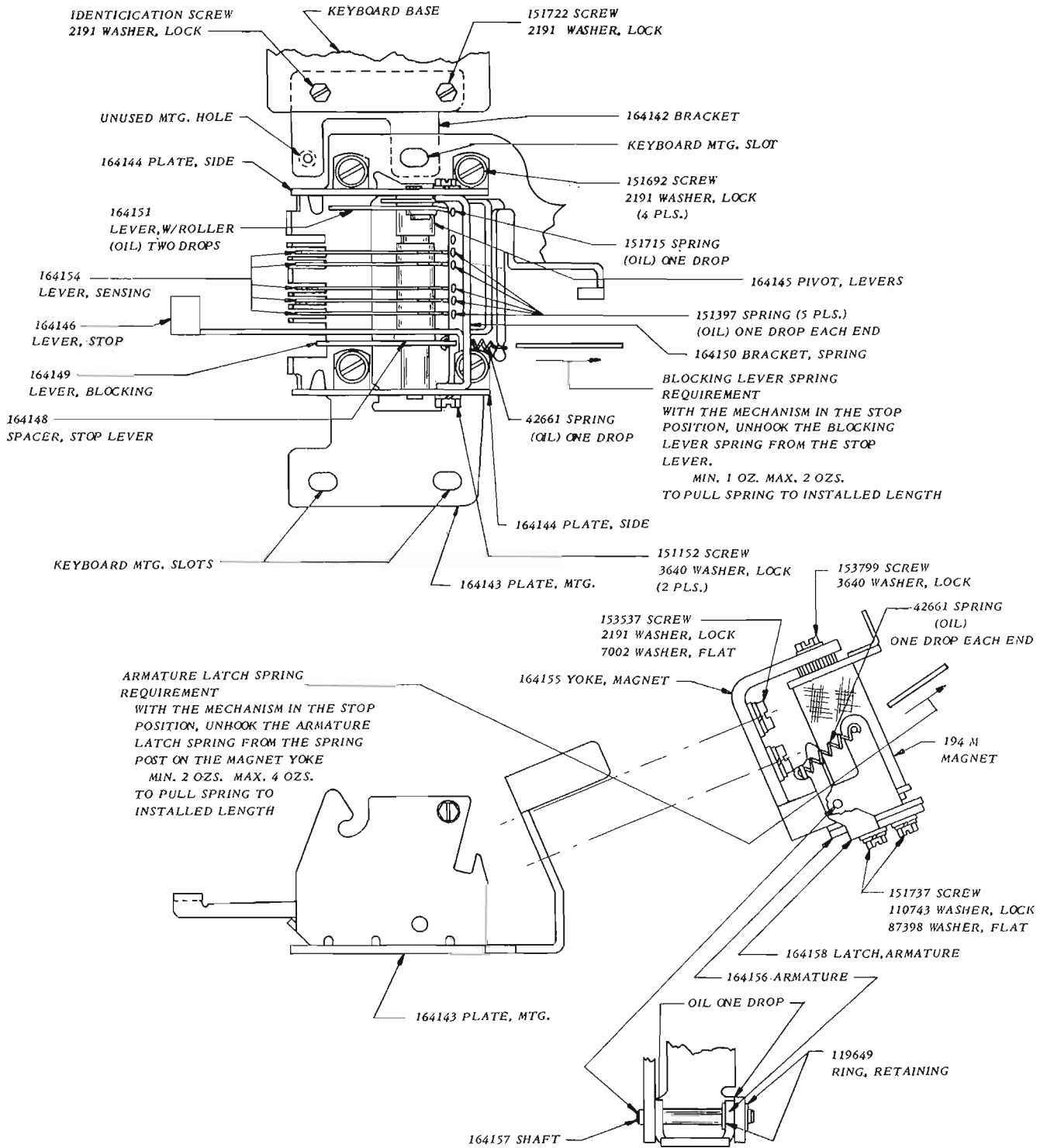
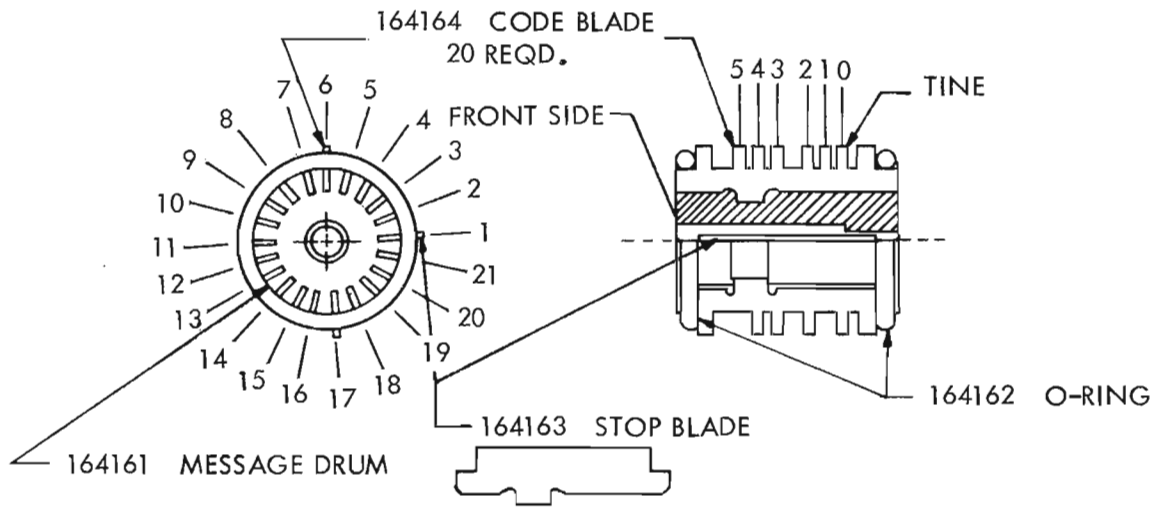

FIGURE 6.



LETTERS	TYPICAL FIG. ARRGT.	CODE				
		1	2	3	4	5
A	—					
B	?					
C	:					
D	\$					
E	3					
F	1					
G	4					
H	#					
I	8					
J	,					
K	(					
L	.					
M	;					
N	9					
O	0					
P	1					
Q	4					
R	BELL					
T	5					
U	7					
V	8					
W	2					
X	7					
Y	6					
Z	"					
CARRIAGE RETURN						
LINE FEED						
LETTERS SHIFT						
FIGURES SHIFT						
SPACE						
BLANK						

■ — LEAVE TINE  
 □ — REMOVE TINE

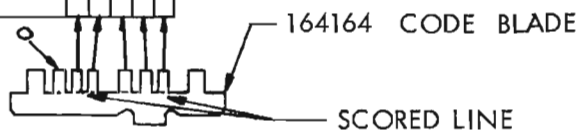

FIGURE 7.

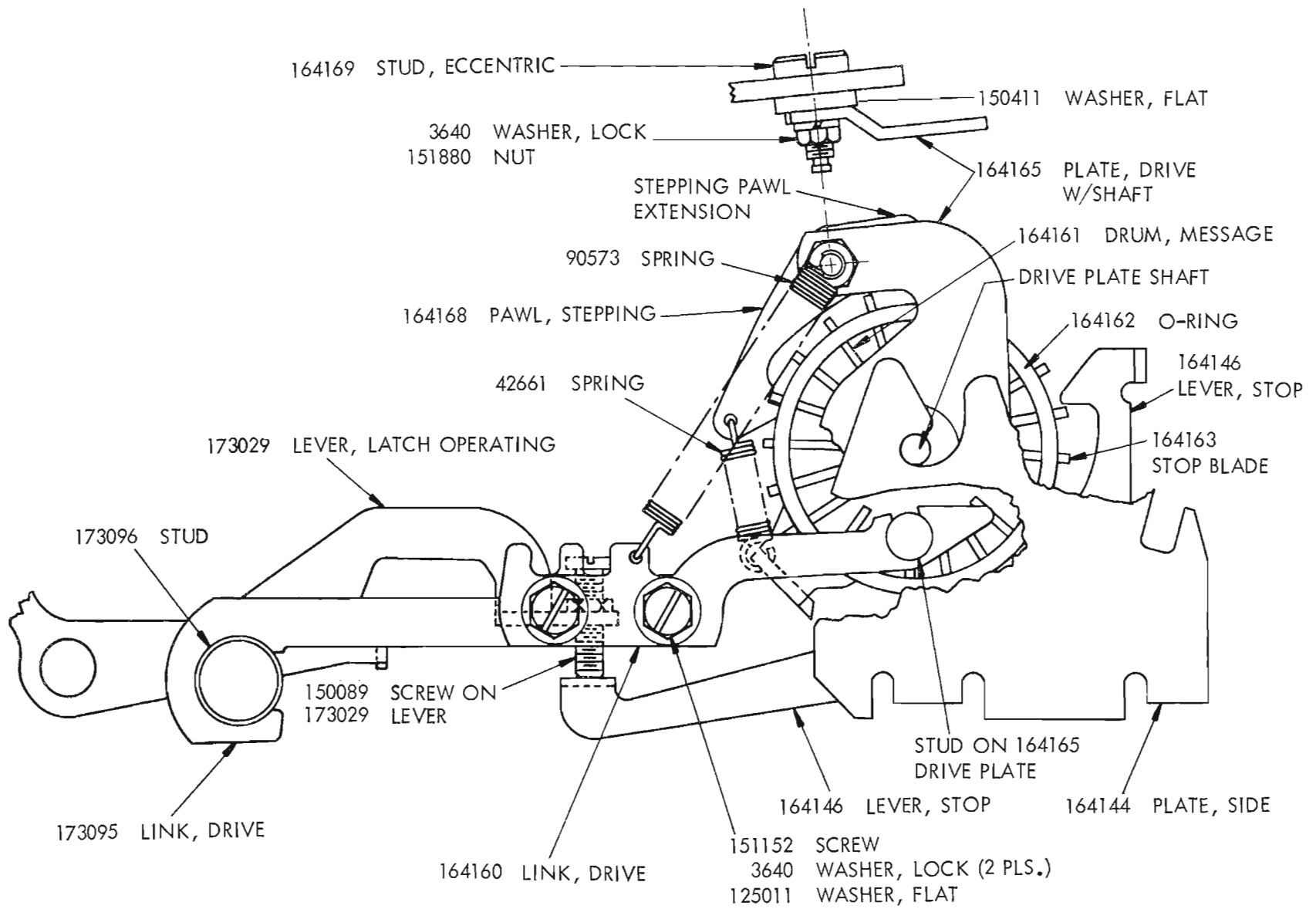
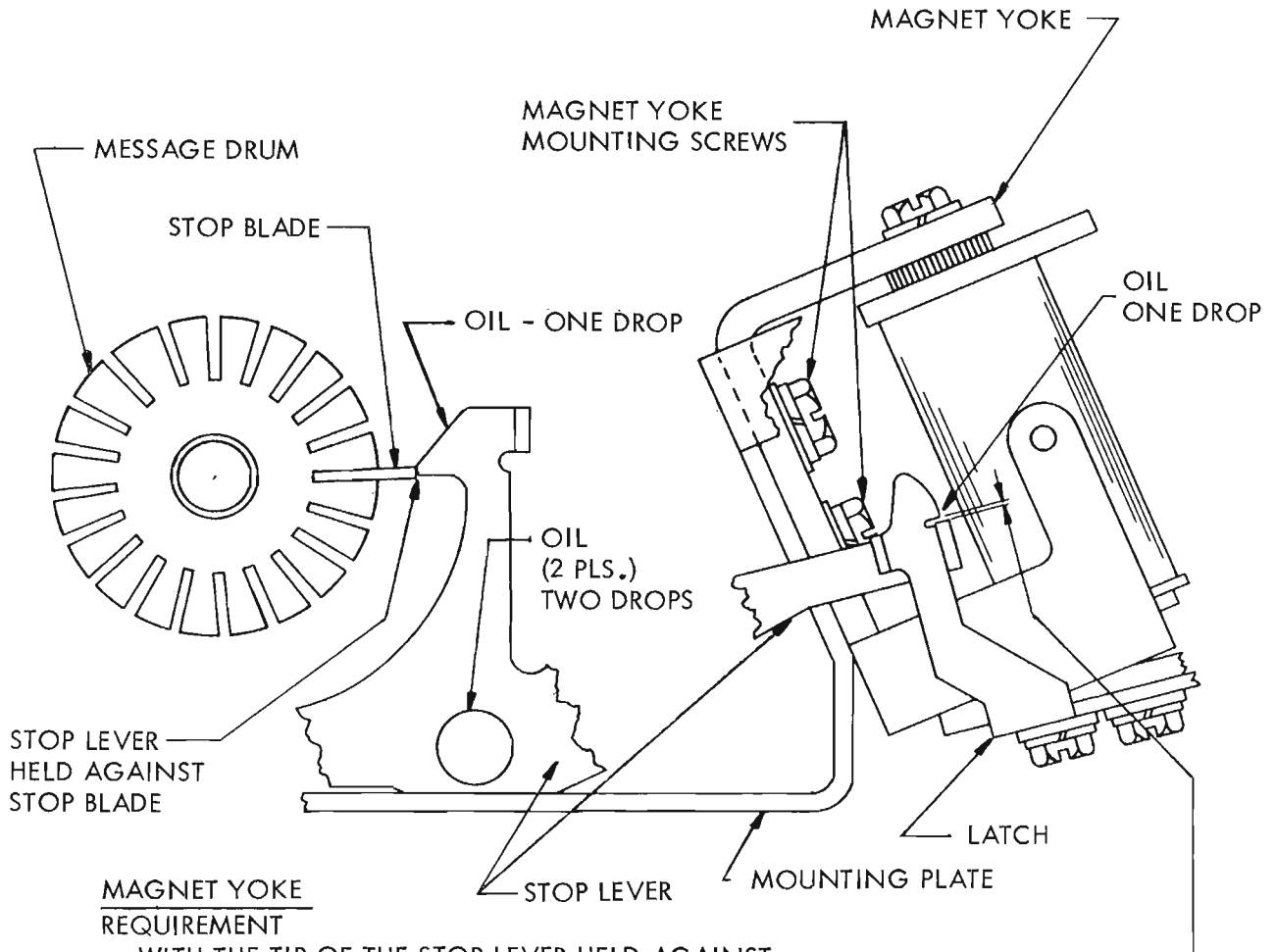

FIGURE 8.

500605



MAGNET YOKE  
REQUIREMENT

WITH THE TIP OF THE STOP LEVER HELD AGAINST THE STOP BLADE THERE SHOULD BE FROM .005" TO .015" CLEARANCE BETWEEN THE LATCHING SURFACES ON THE STOP LEVER EXTENSION AND ITS LATCH

TO ADJUST  
ROTATE THE MESSAGE DRUM TO MEET THE REQUIREMENT AND THEN POSITION THE MAGNET YOKE BY MEANS OF ITS TWO MOUNTING SCREWS.

FIGURE 9.

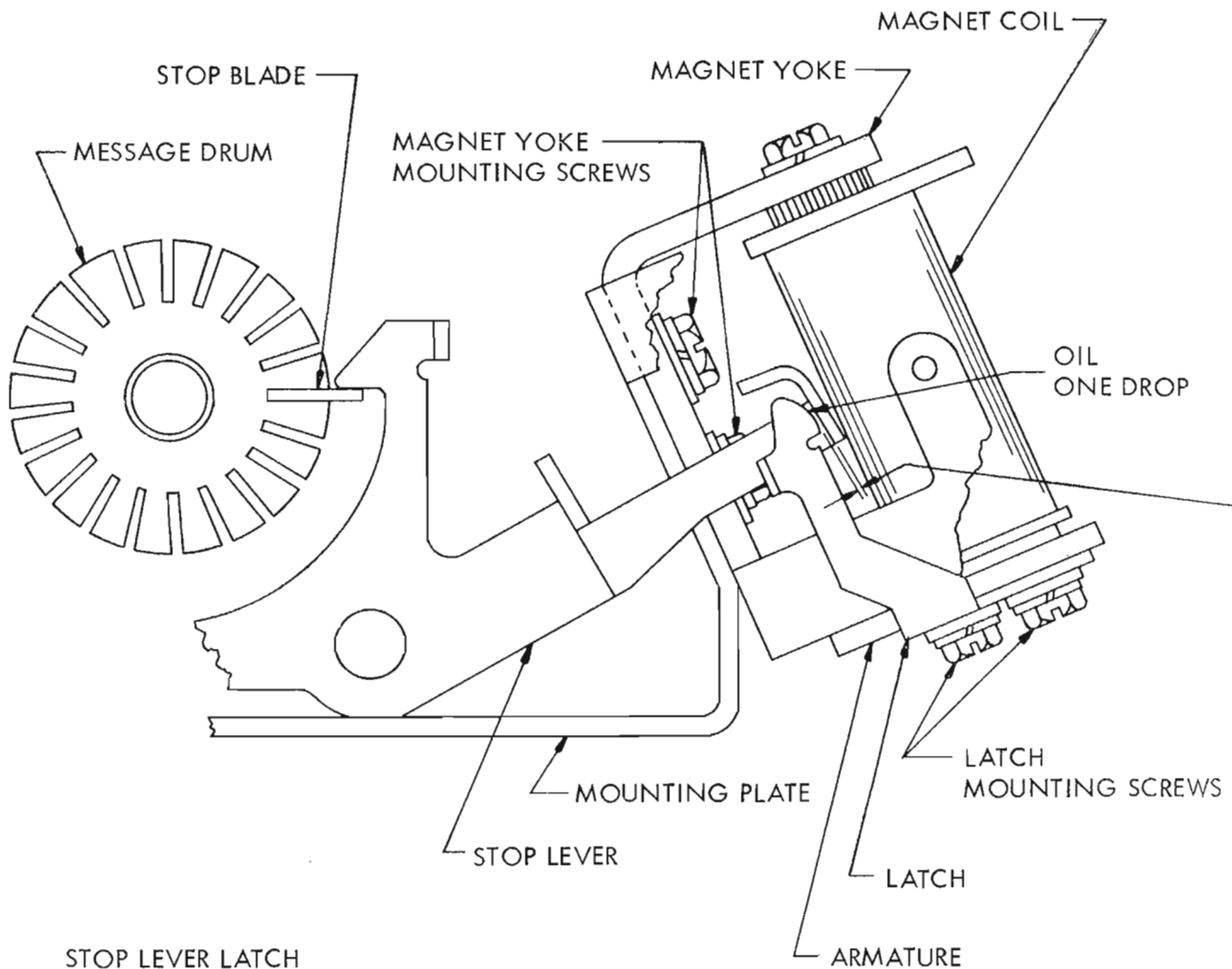

STOP LEVER LATCH  
REQUIREMENT

WITH THE ARMATURE HELD AGAINST THE MAGNET CORE AND THE STOP LEVER HELD IN ITS EXTREME COUNTER-CLOCKWISE POSITION THERE SHOULD BE .002" TO .007" CLEARANCE BETWEEN THE STOP LEVER AND ITS LATCH. THERE SHOULD ALSO BE A MINIMUM OF .002" CLEARANCE BETWEEN THE STOP LEVER AND ITS LATCH THROUGHOUT THE COMPLETE TRAVEL OF THE STOP LEVER.  
TO ADJUST  
POSITION THE LATCH BY MEANS OF ITS TWO MOUNTING SCREWS.

FIGURE 10.

50060S

SENSING LEVER SPRINGS

REQUIREMENT

WITH THE MECH. IN STOP POSITION AND THE MESSAGE DRUM REMOVED  
MIN. 1/4 OZ. --- MAX. 1-1/4 OZS.  
TO START EACH LEVER MOVING

SENSING LEVERS RESTING ON MOUNTING PLATE

DETENT LEVER RESTING ON MTG. PLATE

DETENT LEVER SPRINGS

REQUIREMENT

WITH THE MECH. IN STOP POSITION AND THE MESSAGE DRUM REMOVED  
MIN. 22 OZS. --- MAX. 26 OZS.  
TO START LEVER MOVING

OIL - ONE DROP (5 PLS.)

CODE BARS

SENSING LEVERS

OIL - ONE DROP (BOTH SIDES)

OIL - TWO DROPS (5 PLACES)

- 1
- 2
- 3
- 4
- 5

OIL - ONE DROP (5 PLACES)

MOUNTING PLATE

MOUNTING SCREWS

CHARACTER GENERATOR MOUNTING PLATE

REQUIREMENT

SIGNAL GENERATOR CLUTCH DISENGAGED. (1) SENSING LEVERS CENTRALLY LOCATED ON CODE BARS SO THAT EACH LEVER RESTS ON THE FULL WIDTH OF ITS ASSOCIATED CODE BAR. (2) CLEARANCE BETWEEN SHOULDERS OF CODE BARS NO. 1 NO. 5 AND THEIR ASSOCIATED SENSING LEVERS.

MIN. .002 INCH

MAX. .012 INCH

TO ADJUST

POSITION THE MOUNTING PLATE WITH THE THREE MTG. SCREWS LOOSENED. THIS ADJUSTMENT IS FACILITATED BY REMOVING THE MESSAGE DRUM AND DRIVE PLATE ASSEMBLY FROM THE MECHANISM.

FIGURE 11.



FIGURE 12.

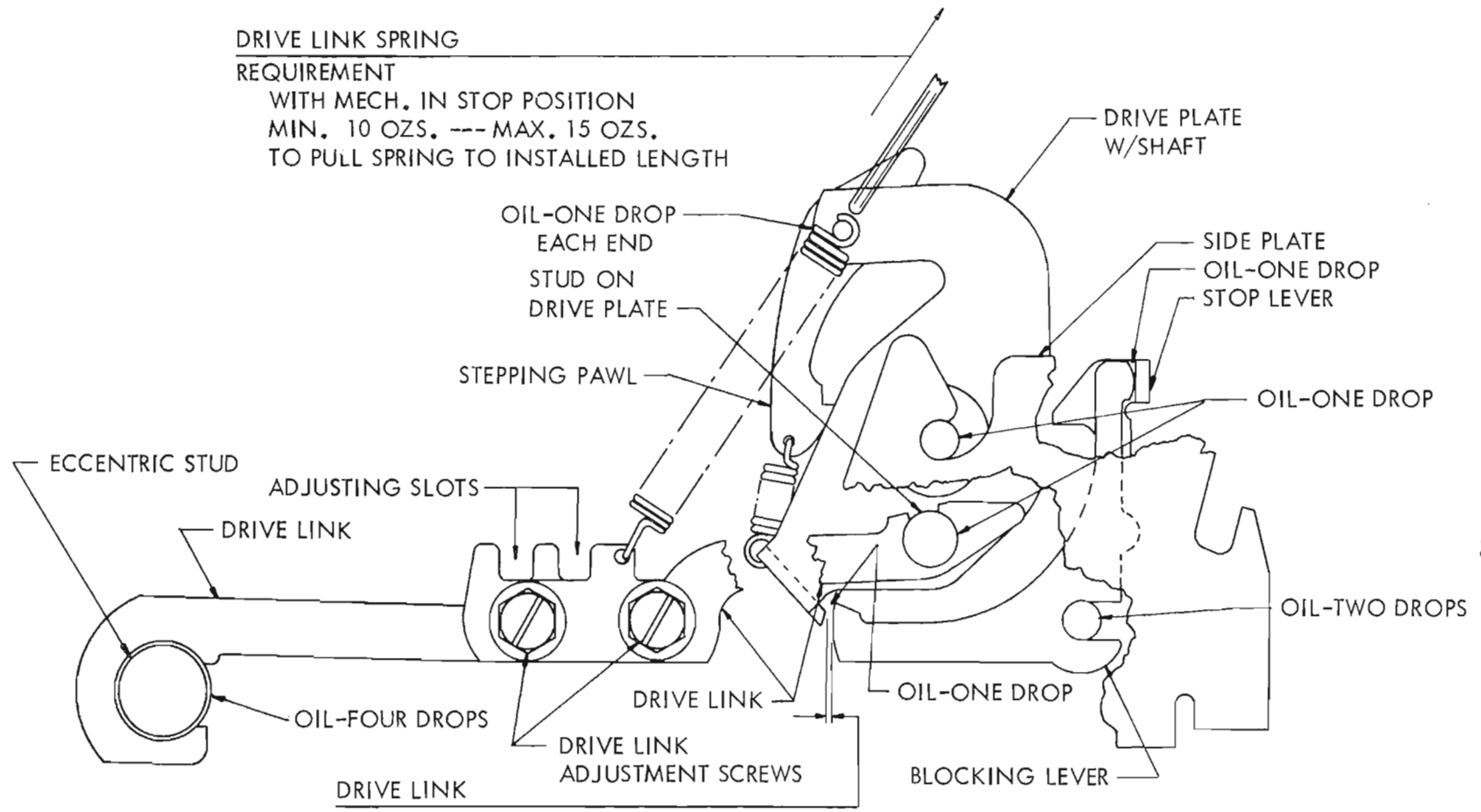

500605

DRIVE LINK SPRING  
REQUIREMENT  
 WITH MECH. IN STOP POSITION  
 MIN. 10 OZS. --- MAX. 15 OZS.  
 TO PULL SPRING TO INSTALLED LENGTH

DRIVE LINK  
REQUIREMENT  
 KEYBOARD MECHANISM:  
 SIGNAL GENERATOR CAM ECCENTRIC AND ARM HOLDING CODE BAR  
 BAIL IN EXTREME RESET POSITION TO THE LEFT.

THERE SHOULD BE .002" TO .007" CLEARANCE BETWEEN  
 THE DRIVE PLATE EXTENSION AND THE BLOCKING  
 LEVER.

TO ADJUST:  
 POSITION THE TWO DRIVE LINKS RELATIVE TO EACH OTHER BY MEANS OF  
 THE ADJUSTING SLOTS AND SCREWS.

FIGURE 13.

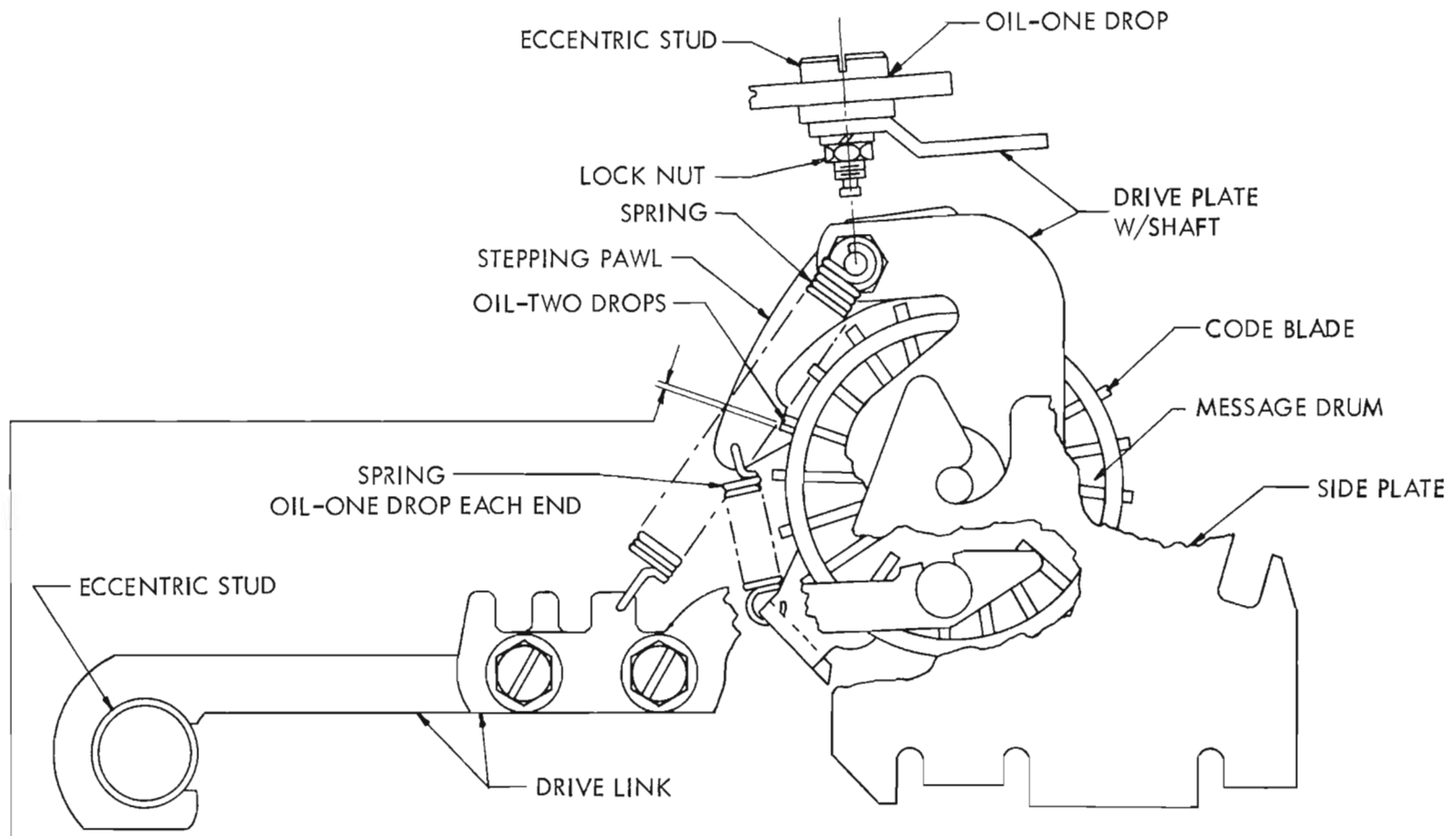

STEPPING PAWL  
REQUIREMENT

MESSAGE DRUM IN FULLY DETENTED POSITION. SIGNAL GENERATOR CAM AND ARM HOLDING CODE BAR BAIL IN EXTREME RESET POSITION TO THE LEFT. THERE SHOULD BE .018" TO .030" CLEARANCE BETWEEN THE STEPPING PAWL AND ANY CODE BLADE.

TO ADJUST

POSITION THE ECCENTRIC STUD WITH ITS LOCK NUT LOOSENED SO THAT ITS HIGH POINT IS TOWARD THE TOP.

FIGURE 14.

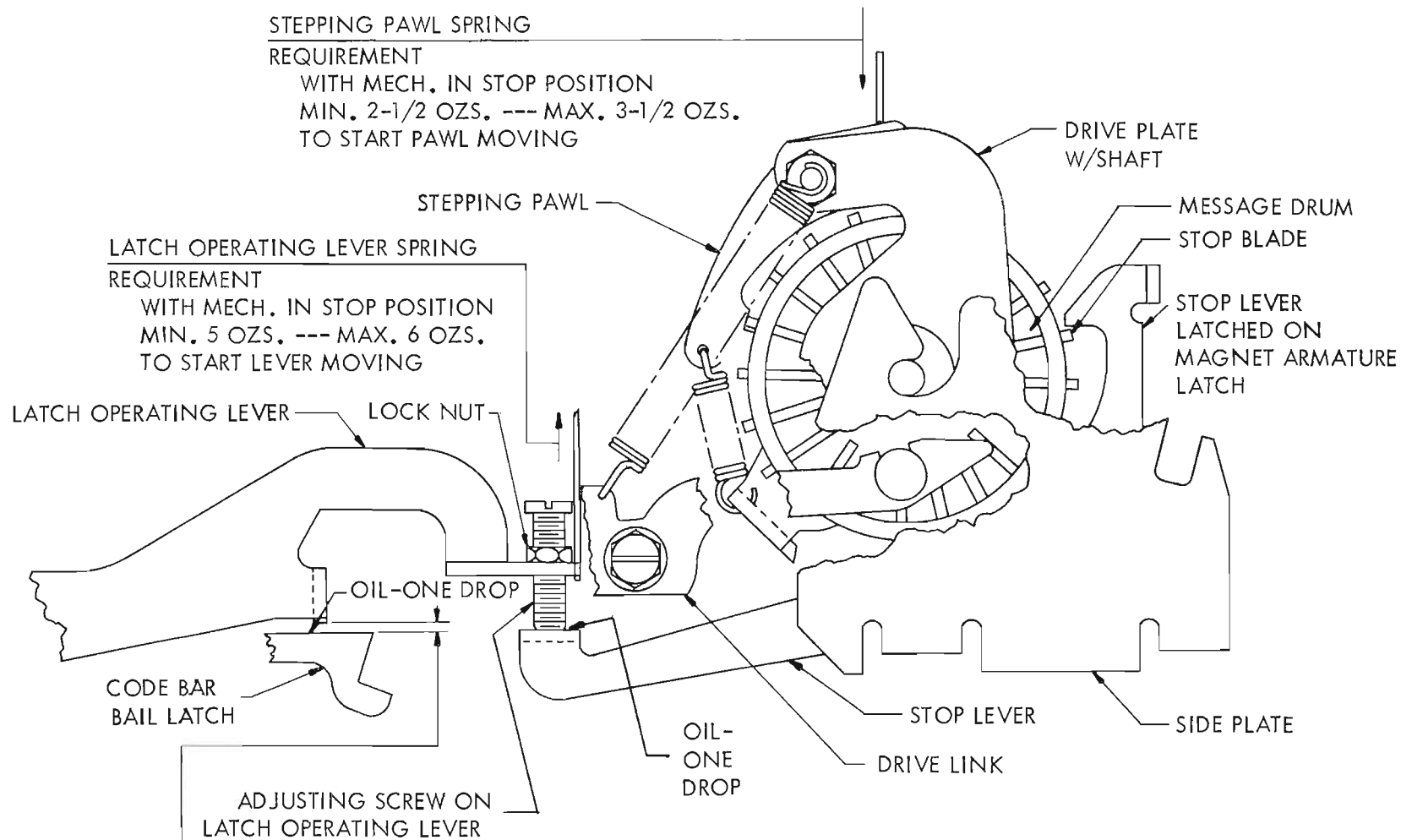

500605

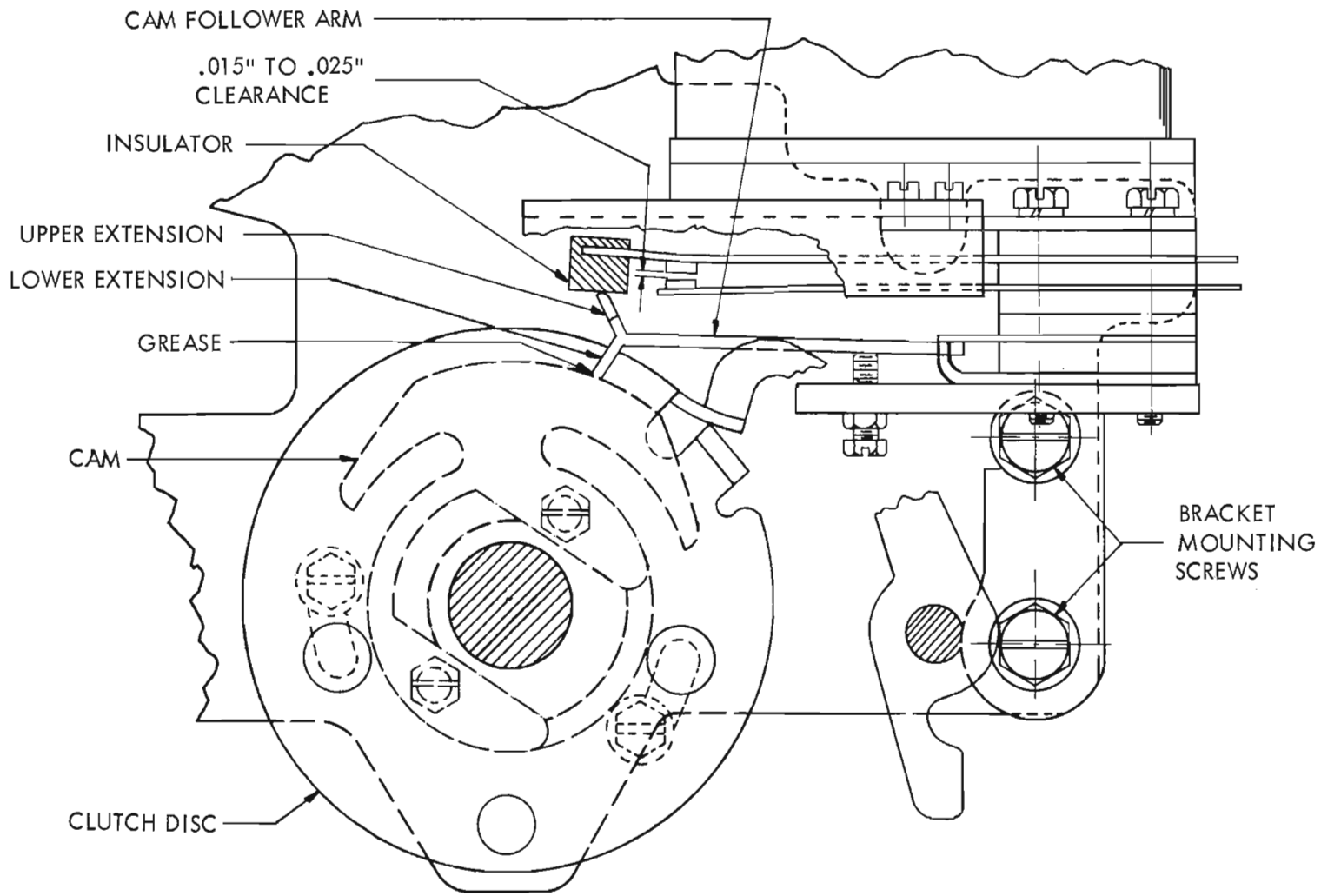

FIGURE 15.

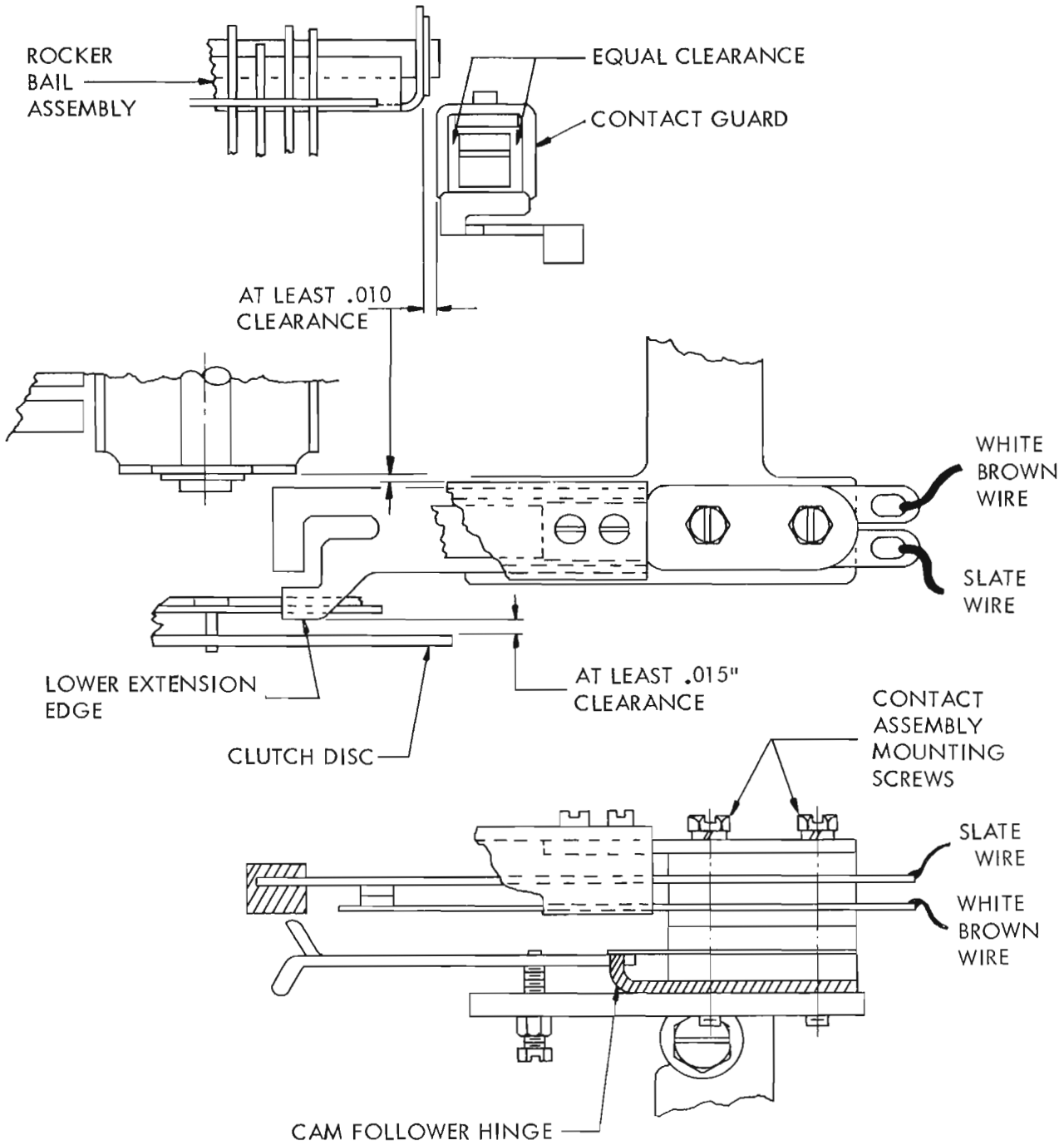

FIGURE 16.

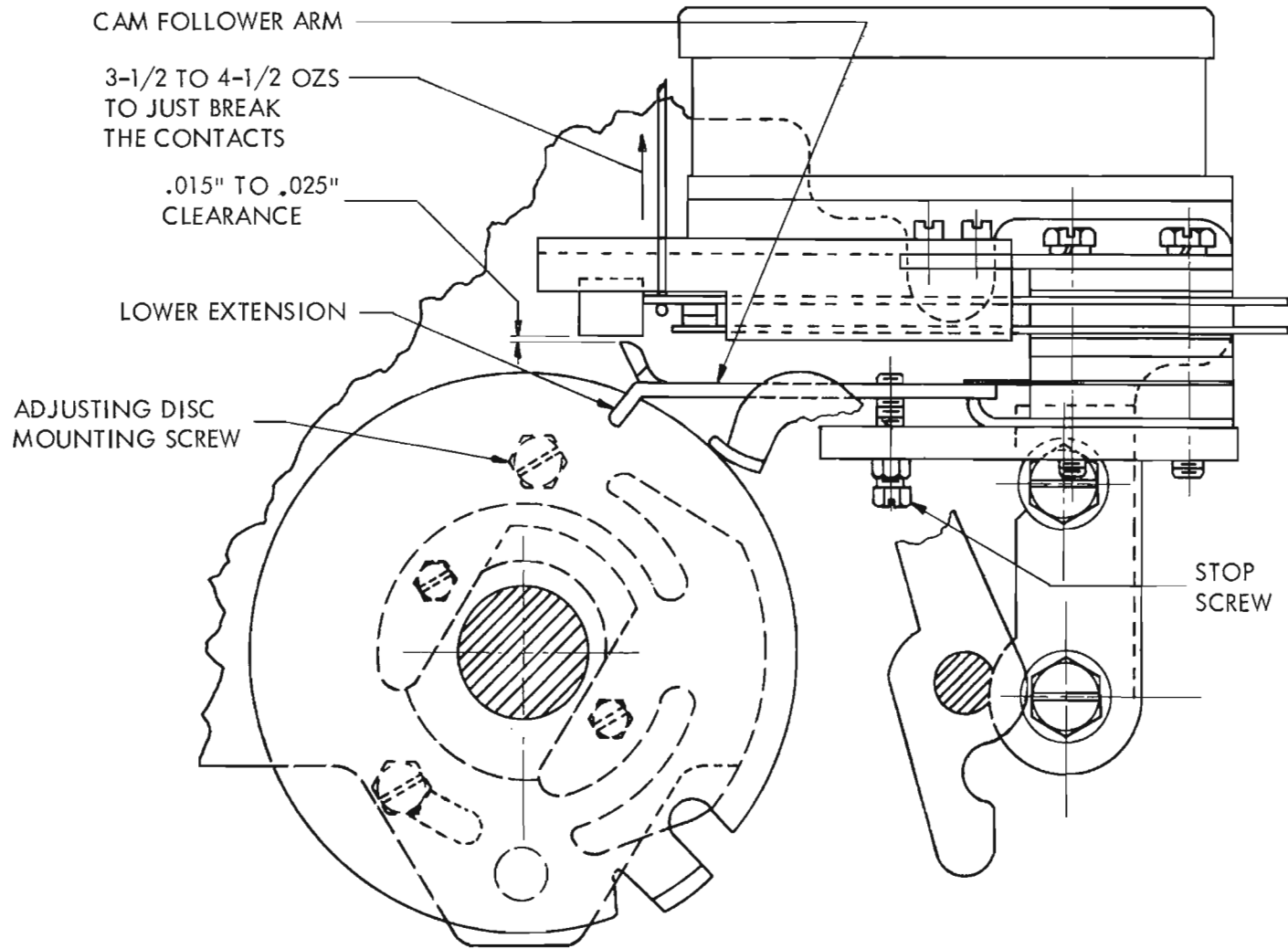
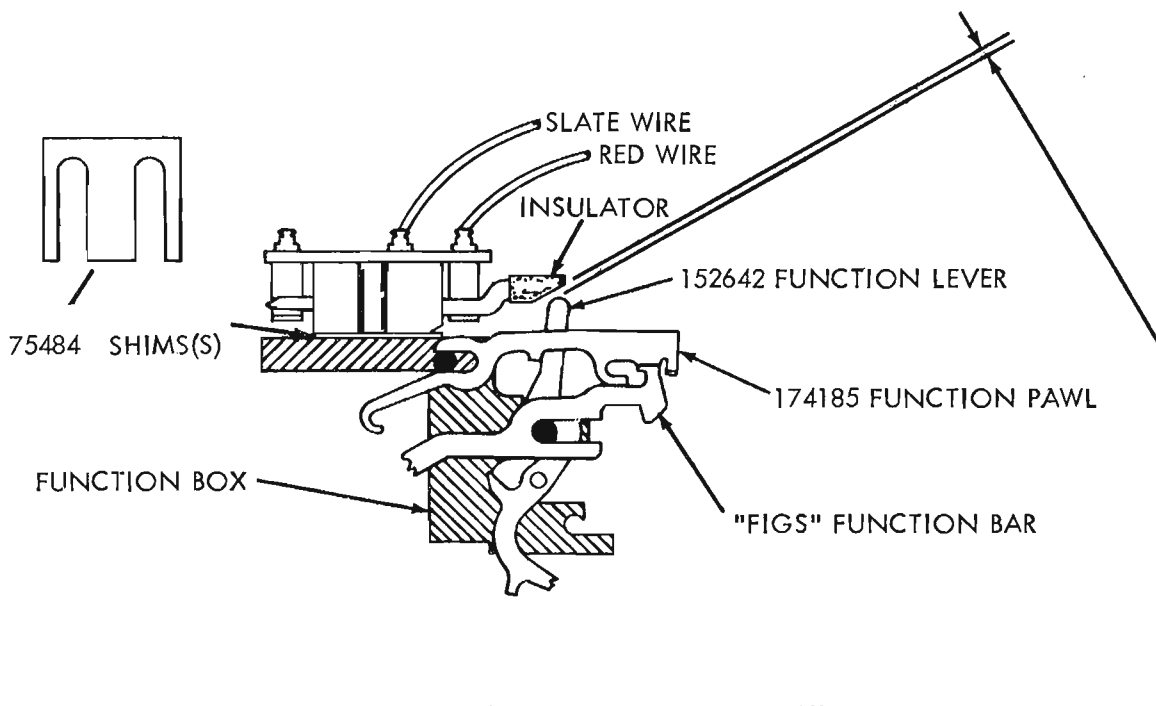

FIGURE 17.



"FIGURES" STUNT BOX CONTACT (FUNCTION BOX SLOT 32)

REQUIREMENT

WITH STUNT BOX ON TYPING UNIT AND "LETTERS" COMBINATION MANUALLY SET UP ON TYPING UNIT SELECTOR MECHANISM, ROTATE TYPING MAIN SHAFT UNTIL FUNCTION LEVER IS IN EXTREME FORWARD (TOWARD CONTACT INSULATOR) POSITION AS SHOWN --- SOME TO 0.005 INCH CLEARANCE BETWEEN CONTACT INSULATOR AND FUNCTION LEVER.

TO ADJUST

ADD OR REMOVE SHIMS UNTIL REQUIREMENT IS MET.

FIGURE 18.