

HIGH SPEED TAPE PUNCH UNIT

(DRPE TYPE)

DISASSEMBLY AND REASSEMBLY

CONTENTS	PAGE
1. GENERAL.....	1
2. BASIC UNIT	3
SILICON RECTIFIER SWITCH ASSEMBLY.....	3
CABLE AND CONNECTOR.....	3
TAPE FEED MECHANISM.....	4
YIELD SPRING	4
A. Disassembly	4
B. Reassembly.....	6
TAPE FEED MOTOR	6
SPUR GEAR AND DRIVE SPRING SLEEVE ASSEMBLY.....	7
TAPE FEED MOTOR SWITCH	7
TAPE PULLER CONTACT ASSEMBLY.....	7
TAPE GUIDE.....	7
TAPE PULLER MOTOR WITH DRIVE ROLLER.....	7
PRESSURE ROLLER AND BAIL ASSEMBLY.....	7
STANDARD PUNCH BLOCK ASSEMBLY.....	7
MAGNET ASSEMBLIES.....	8
3. VARIABLE FEATURES.....	8
PHOTOELECTRIC READER (VERIFIER).....	8
UNIVERSAL PUNCH BLOCK	10
PUNCH BACKUP MECHANISM.....	10

1. GENERAL

1.01 This section provides disassembly and reassembly instructions for the high speed tape punch unit (DRPE type) It is re-issued to add engineering changes, new 2400 word per minute models, and variable features. The variable features include a backup mechanism, photoelectric reader (verifier), and a universal punch block. Since this is a general revision, marginal arrows, used to indicate changes, are omitted. The photographs used in this section are representative of most models.

1.02 The disassembly procedure given divides the high speed tape punch unit into its major subassemblies in the reverse order to that normally used in the assembly of a new unit. If further disassembly is required, refer to Section 592-803-800TC which shows detailed arrangements of parts.

1.03 Most maintenance, lubrication, and adjustments can be accomplished simply by removing the unit from its enclosure. If possible, disassembly should be confined to subassemblies, which can, in some cases, be removed without disturbing adjustments. When reassembling subassemblies, be sure to check all associated adjustments, clearances, and spring tensions.

1.04 If a part that is mounted on shims is removed, note the number of shims used at each of its mounting screws so that the same shim pile-up can be replaced when the part is remounted.

1.05 Retaining rings are made of spring steel and have a tendency to release suddenly. To avoid loss of these rings when removing them, proceed as follows: hold retaining ring to prevent it from rotating. Place the blade of a screwdriver in one of the rings slots. Rotate the screwdriver in a direction to increase the rings diameter. The ring will come off easily without flying.

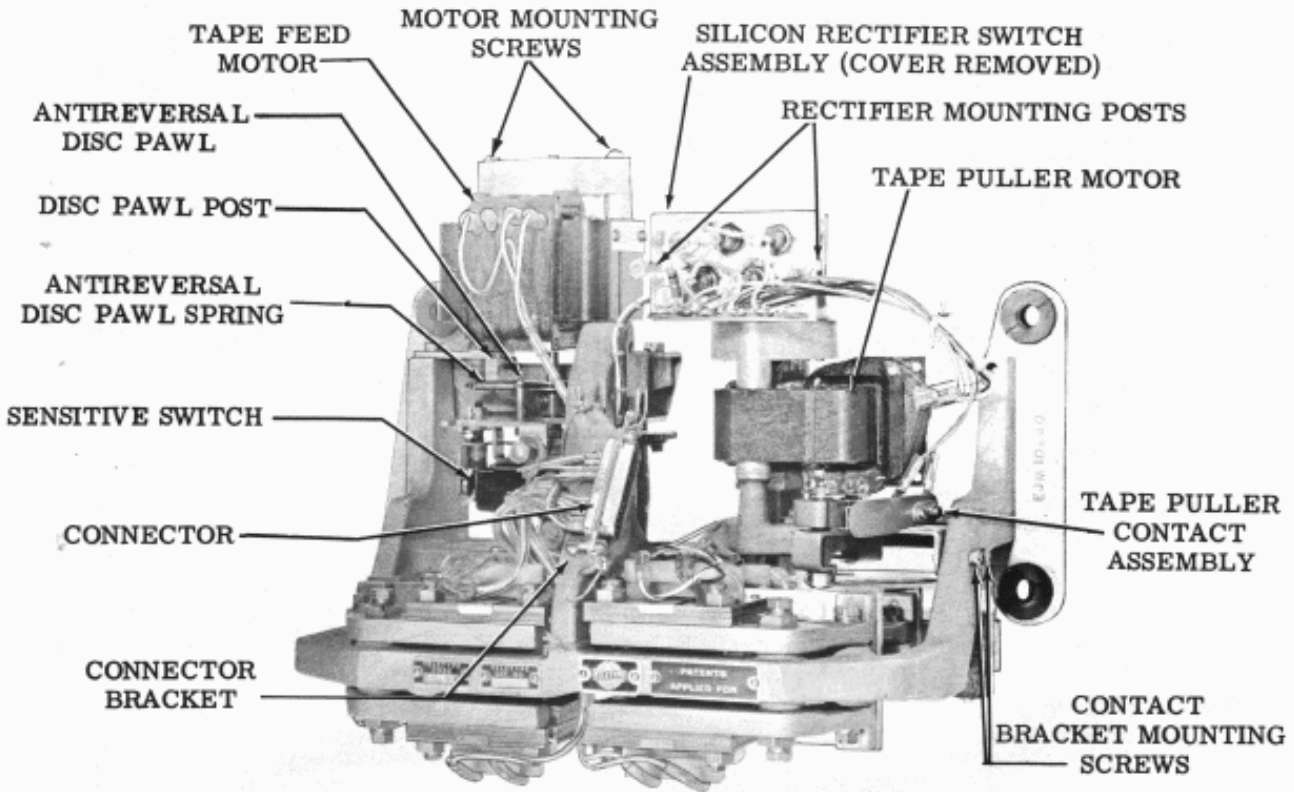

Figure 1 - Five-Level Punch Unit, Top View (2000 WPM)

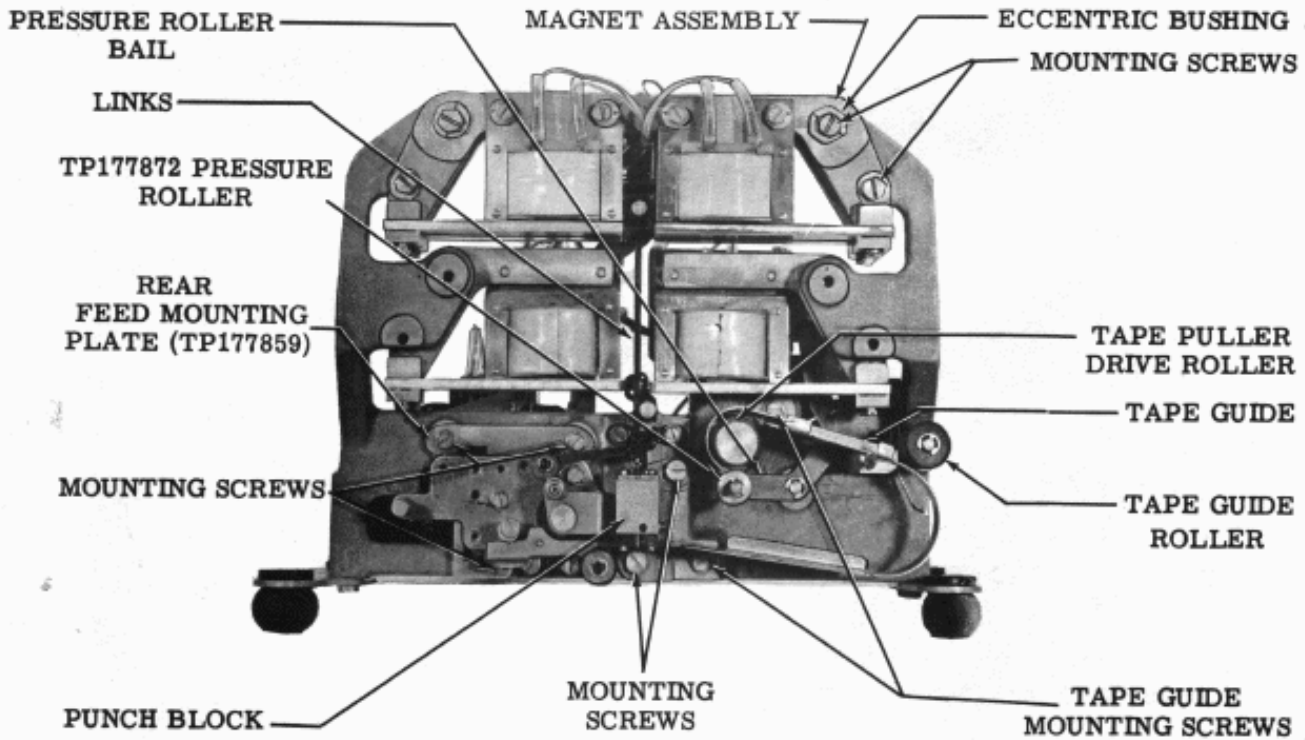

Figure 2 - Five-Level Punch Unit, Front View (2000 WPM)

1.06 Avoid loss of springs in disassembly by holding one spring loop with the left hand while gently removing the opposite loop with a spring hook. Do not stretch or distort springs while removing them.

1.07 In removing a subassembly from the unit, the procedure followed, and the location from which parts are removed, should be carefully noted so that the unit can be reassembled correctly. Where no specific instructions are given for reassembly, reverse the procedure used in removing the subassembly. When reassembling, follow the adjustment sequence in Section 592-803-700 if the unit has been disassembled farther than subassemblies. Use this section to recheck adjustments after reassembly is complete.

1.08 Refer to Section 570-005-800 for information about the tools necessary for disassembly and reassembly procedures given in this section.

CAUTION: REMOVE POWER FROM UNIT BEFORE BEGINNING DISASSEMBLY PROCEDURES.

2. BASIC UNIT

SILICON RECTIFIER SWITCH ASSEMBLY (Figure 1)

2.01 To remove the silicon rectifier switch assembly:

- (1) Pull associated quick disconnect cable terminals from the cable assembly connector and both motors, and either remove the sensitive switch and tape puller contact switch, or remove the connecting wires to these switches.
- (2) Remove the cover (TP148319) by removing the two cover mounting post screws (TP151630) and lockwashers (TP2191).
- (3) While holding the assembly with one hand, remove the two nuts (TP3598) and lockwashers (TP2191) that mount the assembly to the motor bracket.

CABLE AND CONNECTOR (Figure 1)

2.02 To remove the connector only, pull the cable terminal pins out of the connector and remove the two screws, lockwashers, and

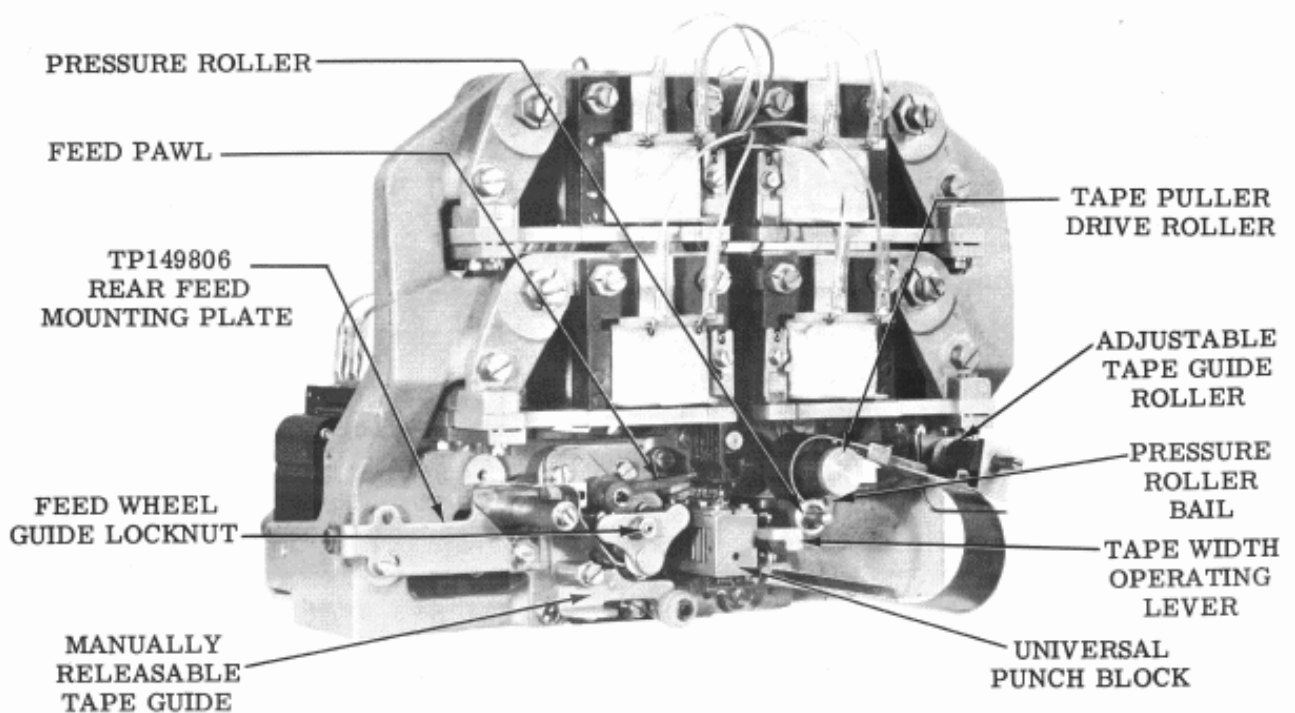

Figure 3 - Eight-Level Punch Unit, Front View (2400 WPM)

nuts that mount the connector to its bracket; or the bracket and connector may be removed as a unit by removing the two bracket mounting screws (TP151630) and lockwashers (TP2191).

TAPE FEED MECHANISM

(Figures 1, 2, 3, and 5)

2.03 To remove the feed mechanism:

- (1) Manually release the torque from the drive spring (2000 wpm, TP177847 or 2400 wpm, TP149833) in steps. Raise and lower the antireversal disc pawl allowing only a small portion of the torque to unwind at a time.

CAUTION: IF TORQUE FROM A FULLY WOUND DRIVE SPRING IS SUDDENLY RELEASED, PERMANENT DAMAGE TO SPRING WILL RESULT. SPRING TENSION SHOULD BE RELEASED IN STEPS AT THE ANTIREVERSAL DISC PAWL.

- (2) After torque is released, loosen only the screw (TP152893) securing the end of the drive spring, under flat washer (TP125011) located on the feed wheel spur gear, and free the drive spring end.

- (3) Remove the three screws (TP151631), lockwashers (TP2191), and flat washers (TP7002) that secure the feed mounting plate (2000 wpm, TP177859, or 2400 wpm, TP149806) to the main casting.

- (4) Using care not to damage the springs or escapement pawl, remove the feed mounting plate with its associated feed mechanisms mounted on it.

YIELD SPRING (Figures 3, 4, and 5)

A. Disassembly

2.04 Before proceeding with the disassembly of the yield spring, the feed mounting plate must be removed as outlined in 2.03. After the mounting plate has been removed, follow the procedure outlined in this paragraph.

- (1) Remove the two retaining rings (TP119651) securing the manually releasable tape guide (TP177865) and remove the guide.
- (2) Remove the ratchet wheel grease retainer (TP147879) (if equipped) by removing its two mounting screws, lockwashers, and flat washers.

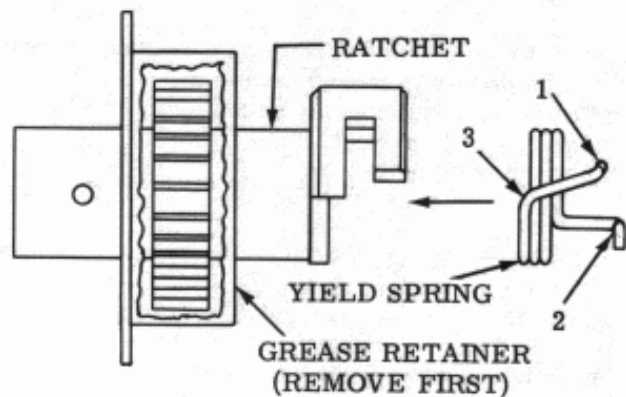

POSITION A

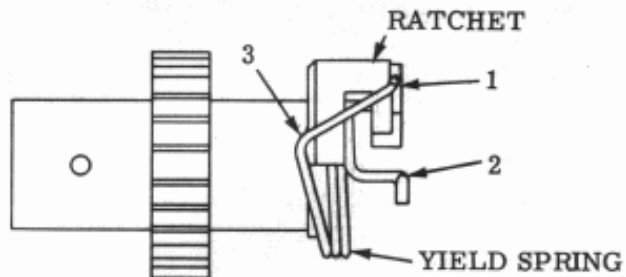

POSITION B

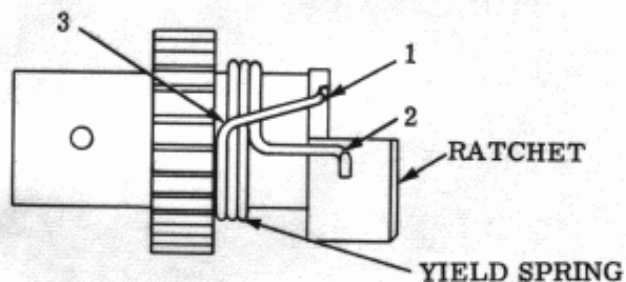

POSITION C

(Right Side Views)

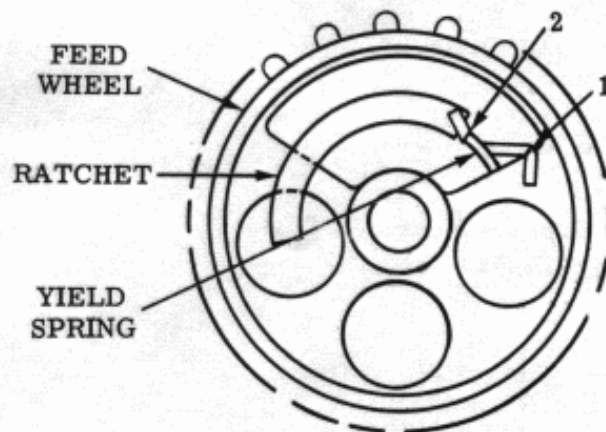

POSITION D

(Front View)

Figure 4 - Yield Spring Assembly

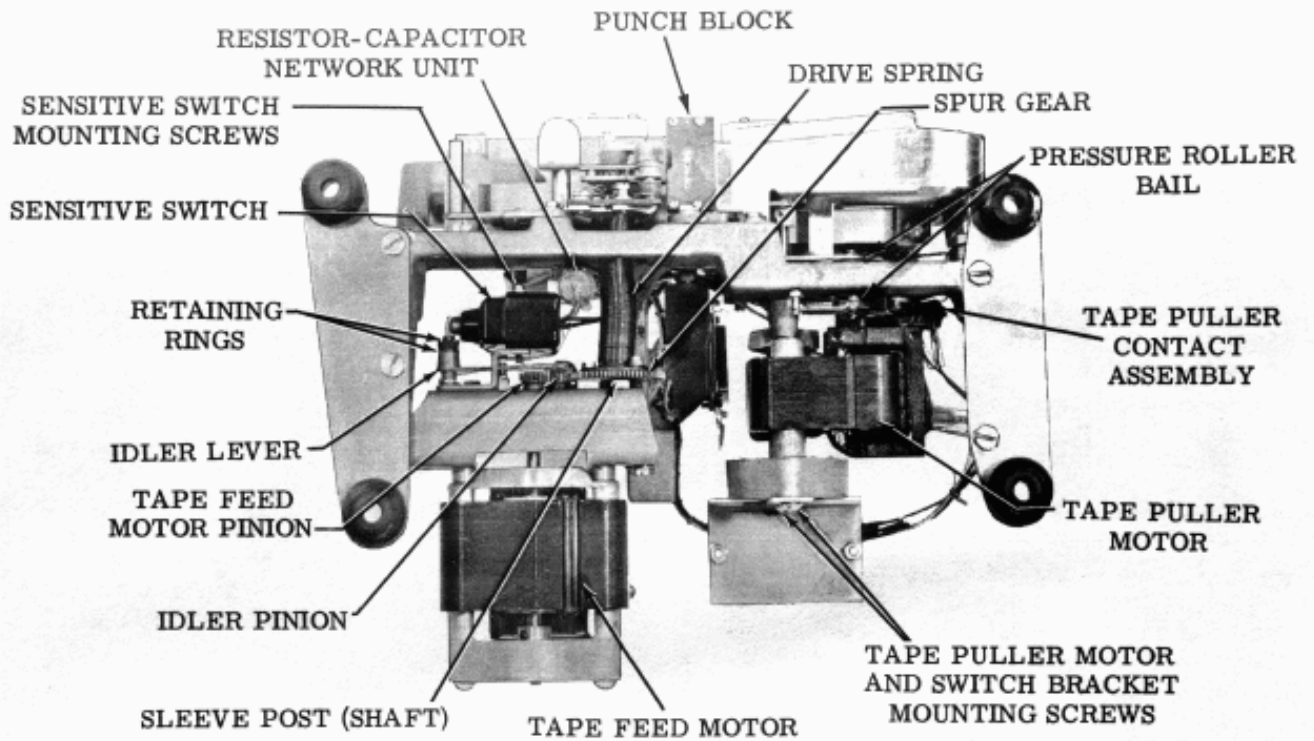

Figure 5 - Five-Level Punch Unit, Bottom View (2000 WPM)

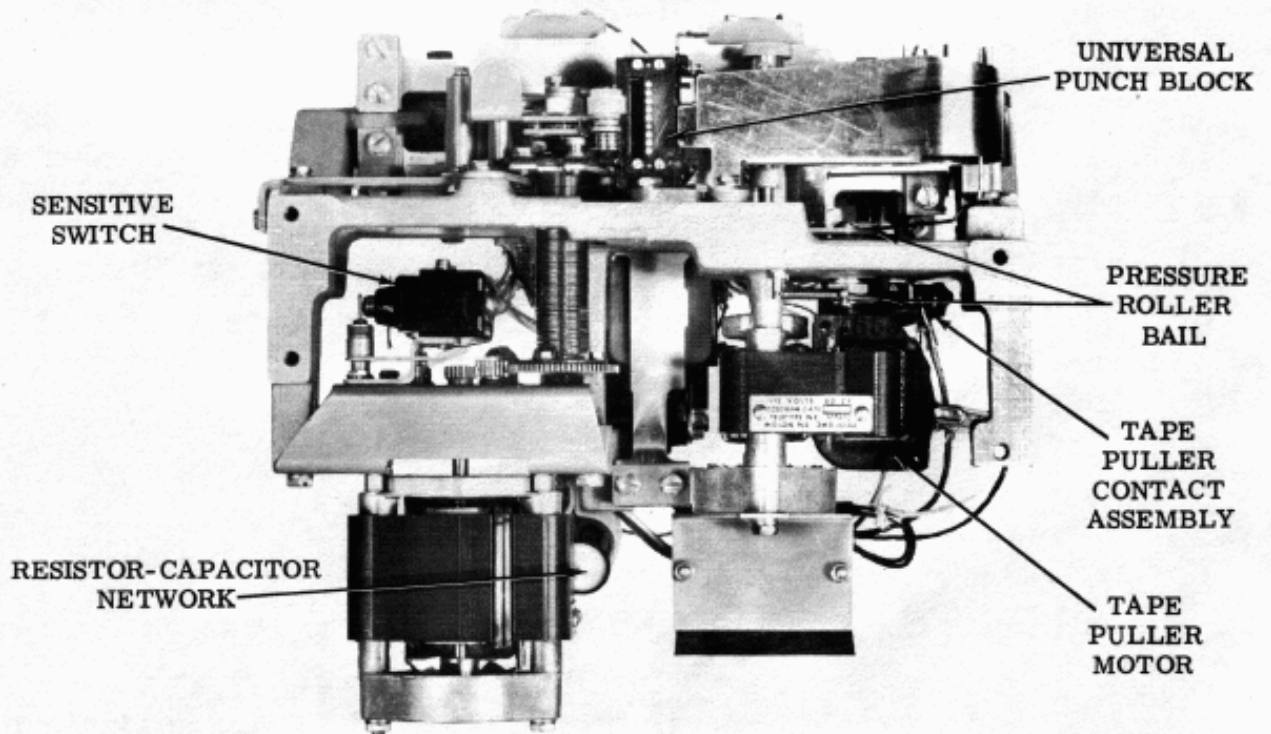

Figure 6 - Eight-Level Punch Unit, Bottom View (2400 WPM)

SECTION 592-803-702TC

- (3) Remove the feed (escapement) pawl (TP177815) and its eccentric post (TP177856) by removing the nut (TP3598) and lockwasher (TP2191) that secure the eccentric post to the feed wheel plate.
- (4) Remove the feed wheel guide locknut (TP3598) and lockwasher (TP2191) and, with an Allen wrench, screw the feed wheel guide (2000 wpm, TP177863, or 2400 wpm, TP149801) in toward the rear of the unit until the feed wheel is released.
- (5) Remove the feed wheel, yield spring and ratchet, and the drive spring as an assembly through the rear of the feed wheel plate.
- (6) Referring to Figure 4, disengage ratchet and yield spring (shown in position D) by carefully gripping bend 1 with a long nose pliers and pulling the spring away from the feed wheel.
- (7) Unwind the yield spring counterclockwise while holding bend 2 with a long nose pliers.

B. Reassembly

- 2.05 To reassemble the yield spring to the ratchet and feed wheel:

- (1) Bring the yield spring to the ratchet as shown in Figure 4, position A.
 - (2) Using a long nose pliers to hold bend 1, lift bend 3 over ratchet as shown in Figure 4, position B.
 - (3) Still holding bend 1 with pliers, turn the yield spring clockwise onto the ratchet with bend 2 in place as shown in Figure 4, position C.
- Note: At this point, lubricate the ratchet and feed wheel as specified in Section 592-803-701. Also, fill the ratchet wheel grease retainer with lubricant specified in Section 592-803-701.
- (4) Assemble feed wheel to ratchet with yield spring bends in place as shown in Figure 4, position D.

TAPE FEED MOTOR (Figures 1 and 5)

- 2.06 To remove the tape feed motor with its pinion:

- (1) Pull the cable connectors from the motor terminals.
- (2) Remove the antireversal disc pawl spring (TP70466).

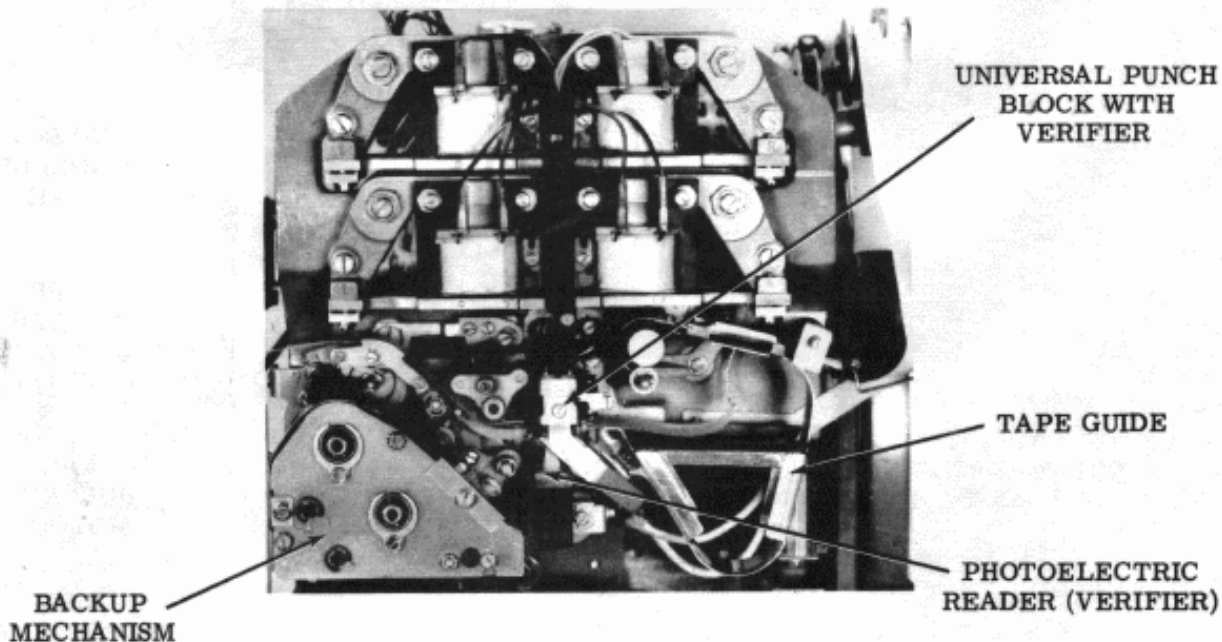

Figure 7 - Punch Unit with Backup Mechanism, Photoelectric Reader (Verifier), and Universal Punch Block with Verifier, Front View

(3) Remove the antireversal disc pawl post (TP149828), which still has the pawl and ring retainer on it.

(4) While holding the motor with one hand, remove the nut (TP112626), lockwasher (TP2669), and flat washer (TP34432) that secures the right hand motor stud to the mounting bracket.

(5) Carefully maneuver the motor out from the rear of the bracket.

SPUR GEAR AND DRIVE SPRING SLEEVE ASSEMBLY (Figures 5 and 6)

2.07 To remove the spur gear and drive spring sleeve assembly:

(1) Remove the nut (TP112626) and lockwasher (TP2669) that secure the drive shaft (TP177845) to the motor bracket.

(2) Carefully remove the spur gear and drive springsleeve assembly through the front of the unit.

TAPE FEED MOTOR SWITCH (Figures 5 and 6)

2.08 To remove the tape feed motor switch from its bracket, disconnect the switch wires from the silicon rectifier switch assembly first; then remove the two screws, lockwashers, and flat washers that mount the switch.

TAPE PULLER CONTACT ASSEMBLY (Figures 1, 5, and 6)

2.09 To remove the tape puller contact assembly:

(1) Disconnect the wire leads either at the contact pile-up or at the silicon rectifier switch assembly.

(2) Remove the two screws (TP179782) and lockwashers (TP2191) that mount the contact assembly to the main casting.

TAPE GUIDE (Figures 2, 3, and 7)

2.10 To remove the tape guide, remove the two screws (TP151631), lockwashers (TP2191), and flat washers (TP7002) that secure it to the main casting.

TAPE PULLER MOTOR WITH DRIVE ROLLER (Figures 2, 3, 5, and 6)

2.11 To remove the tape puller motor with drive roller:

(1) Disconnect the cable connectors from the motor terminals.

(2) Loosen the two motor mounting screws and remove the silicon rectifier switch assembly.

(3) While holding the motor with one hand, remove the two motor mounting screws, lockwashers, and flat washers from their tapped holes, but do not take them out of the motor assembly.

(4) While holding the pressure roller assembly down with one hand, ease the motor assembly out from the rear of the unit.

PRESSURE ROLLER AND BAIL ASSEMBLY (Figures 2, 5, and 6)

2.12 To remove the pressure roller and bail assembly:

(1) Remove the bail spring (TP90573).

(2) Remove the two ring retainers (TP119652) securing the bail (TP177886) to the shaft (TP177901) and remove the shaft.

(3) Carefully remove the bail assembly from the front of the unit.

STANDARD PUNCH BLOCK ASSEMBLY (Figures 2 and 5)

2.13 To remove the standard punch block assembly:

(1) Remove the lower mounting screw (TP153442), lockwasher (TP2669), and flat washer (TP34432).

(2) While holding the punch block with one hand, remove the screw (TP153442), lockwasher (TP2669), and flat washer (TP34432) from the upper right mounting position.

(3) Carefully tilt the punch block away from the punch pin links and remove it from unit.

- (4) Adjust the punch pin backstop bracket to retain the punch pins while the punch block assembly is removed from the unit.

MAGNET ASSEMBLIES (Figures 2 and 3)

2.14 To remove a magnet assembly:

- (1) Remove the two wire leads to the magnet.
- (2) Remove the upper mounting screw (TP85422), lockwasher (TP3639), flat washer (TP3438), and eccentric bushing (TP177819).
- (3) While holding the magnet assembly with one hand, remove the lower mounting screw (TP74805), lockwasher (TP3639), and flat washer (TP3438).
- (4) Carefully remove the magnet assembly from the punch pin links to disengage the reed from the link.

Note: Late model units have link dampers mounted to the reed extension. Care should be taken when removing magnet assemblies to avoid the loss of these dampers.

3. VARIABLE FEATURES

PHOTOELECTRIC READER (VERIFIER) (Figures 7 and 8)

3.01 To remove the chad chute (Figure 8):

- (1) Remove the chad tube from the chad chute bracket by holding the bracket in one hand and pulling the chad tube off the bracket with the other hand.
- (2) Remove the chad tube bracket by removing the two screws (TP151152), lockwashers (TP3640), and flat washers (TP125011) that secure it to the punch block and adapter bracket.

3.02 To remove the light source assembly (Figure 8):

- (1) Remove the two screws (TP151630), lockwashers (TP2191), and the one flat washer (TP151610) that secure the light source assembly to the left side bracket.
- (2) Disconnect the rubber isolating tube from the mirror tube assembly by holding the mirror tube assembly in one hand while care-

fully pulling the isolating tube with the other hand.

- (3) Carefully move the light source, as far as the leads will allow, and remove the perforated cover by removing its two screws (TP156740) and lockwashers (TP2191).

- (4) Disconnect the two wire leads to the quartz iodine lamp, being careful not to touch the quartz envelope, by removing the nut and lockwasher retaining each lead.

- (a) Quartz Iodine Lamp Burned Out: The lamp can be replaced by removing the two screws and lockwashers that retain it.

CAUTION: WHEN REPLACING LAMP, DO NOT HANDLE QUARTZ GLASS ENVELOPE OF LAMP. REMOVE GREASE OR FINGER PRINTS FROM LAMP BY CLEANING WITH A GREASE FREE SOLVENT SUCH AS ACETONE.

- (b) Quartz Iodine Lamp Operable: If lamp is operable, replace the lockwashers and nuts removed in 3.02 (4) to disconnect the wire leads.

- (5) The light source assembly can now be removed from the unit.

3.03 To remove the mirror tube assembly (Figure 8):

- (1) While holding the mirror tube assembly with one hand, remove the two screws (TP151631), lockwashers (TP2191), and flat washers (TP125015) that secure the assembly to the two angle brackets (TP302972).
- (2) Carefully pull the mirror tube assembly down and away from the punch block with verifier.

CAUTION: THE GLASS PRISM ATTACHED TO THE PUNCH BLOCK, EXTENDS BELOW THE PUNCH BLOCK INTO THE MIRROR TUBE ASSEMBLY. EVERY PRECAUTION MUST BE TAKEN DURING DISASSEMBLY TO AVOID DAMAGING THE GLASS PRISM.

3.04 To remove the punch block assembly with verifier (Figure 8):

- (1) Remove the waxed string that secures the punch block cable (light sensor) to the main casting.

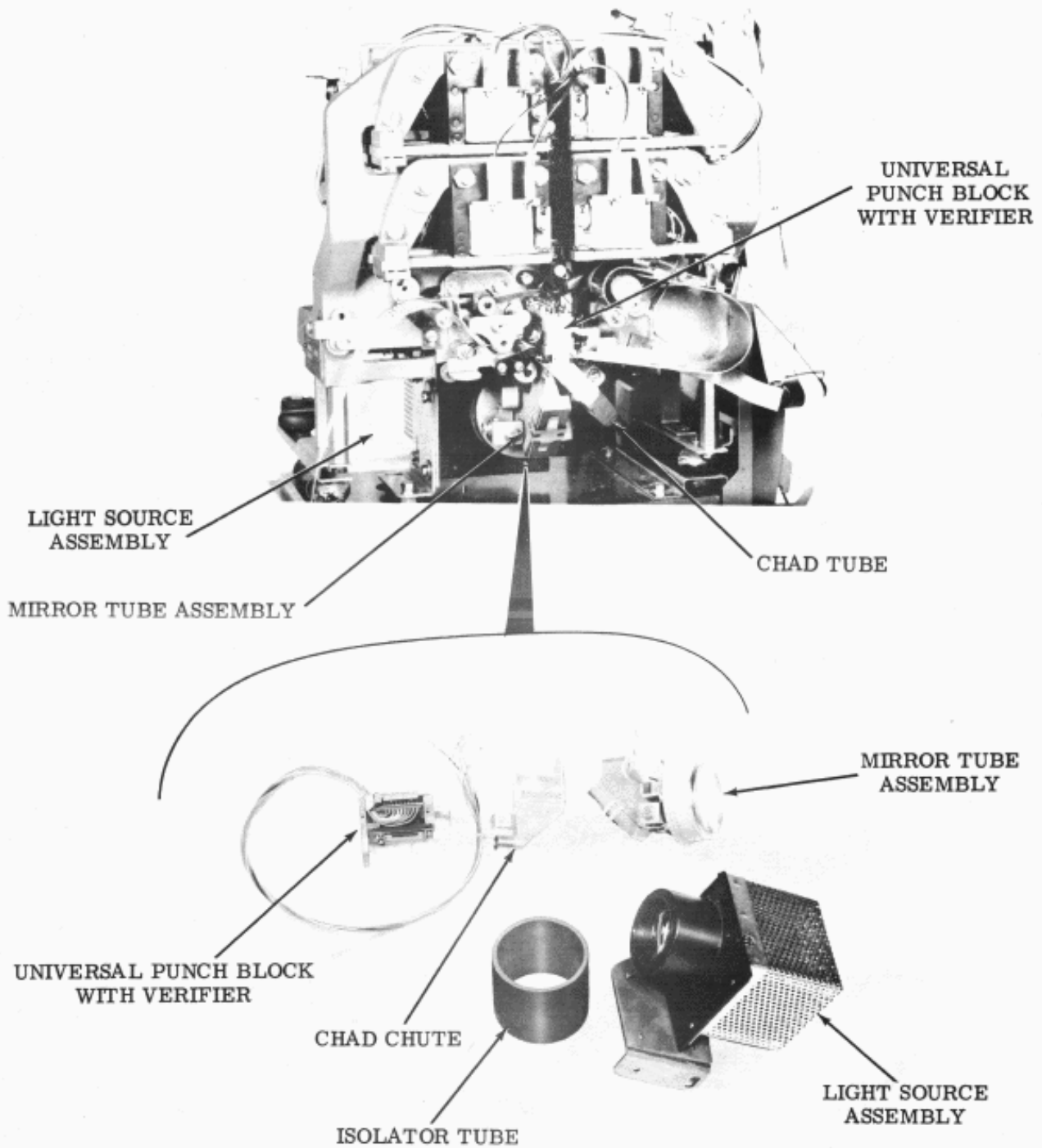

Figure 8 - Eight-Level Punch Unit With Photoelectric Reader, Front View

(2) Remove only those wire leads, from the connector (TP173579) located at the top of the main casting, that are part of the punch cable (light sensor). Use the following chart for wire and pin number identification during disassembly and reassembly operations:

PUNCH BLOCK CABLE (LIGHT SENSOR)		
PIN NUMBER (CONNECTOR TP173579)	WIRE COLOR	CODE LEVEL
18	Black	Common
2	Brown	1
4	Red	2
6	Orange	3
45	White-Green	Feed
8	Yellow	4
10	Green	5
12	Blue	6
14	Purple	7
47	Slate	8

(3) Remove the nut (TP112626), lockwasher (TP2669), and screw (TP74014) from the lower left punch block mounting position.

(4) While holding the punch block with one hand, remove the screw (TP153442), lockwasher (TP2669), and flat washer (TP34432) from the upper right mounting position.

(5) Carefully tilt the punch block away from the punch pin links.

(6) Remove the punch block and cable assembly from the unit with one hand, while guiding the cable assembly with the other hand.

(7) Adjust the punch pin backstop bracket to retain the punch pins while the punch block assembly is removed from the unit.

UNIVERSAL PUNCH BLOCK (Figure 3)

3.05 To remove the universal punch block, follow steps 3, 4, 5, and 7 in 3.04.

PUNCH BACKUP MECHANISM (Figure 9)

3.06 Remove the gear guard (TP302746) by removing its two screws (TP151722), lockwashers (TP2191), and flat washers (TP7002).

3.07 To remove the tape guide assembly (Figures 9 and 10):

(1) Lift the formed end of the tape guide torsion spring (TP320366) off its spring post and allow it to rest on the tape guide assembly lug just to the left of the spring post.

(2) Rotate the tape guide assembly clockwise until the feed pins of both feed wheels are cleared.

(3) Pull the tape guide assembly off its pivot post.

3.08 To remove the backup mechanism from the main casting (Figures 9 and 11):

(1) Manually release the torque from the drive spring (TP149833) in steps. Raise and lower the antireversal disc pawl (TP149834) allowing only a small portion of the torque to unwind at a time.

CAUTION: IF TORQUE FROM A FULLY WOUND DRIVE SPRING IS SUDDENLY RELEASED, PERMANENT DAMAGE TO SPRING WILL RESULT. SPRING TENSION SHOULD BE RELEASED IN STEPS AT THE ANTIREVERSAL DISC PAWL.

(2) After torque is released, loosen only the screw (TP152893) securing the end of the drive spring, under flat washer (TP125011) located on the feed wheel drive gear, and free the drive spring end.

(3) Remove the drive belt (TP309561) from the pulley (TP195795) on the drive shaft assembly by loosening the setscrews (TP80706) and removing the pulley.

(4) While holding the backup mechanism with one hand, remove the two screws (TP151631), lockwashers (TP2191), and flat washers (TP7002) securing the backup mechanism to the main casting.

(5) Carefully ease the backup mechanism out of the unit while disconnecting the escapement pawl (TP177815) from the feed link (TP149811).

3.09 To remove the trip magnet assembly (Figure 11):

(1) Remove the two screws (TP151631) and lockwashers (TP2191) holding the magnet bracket (TP320373) to the rear plate (TP320304).

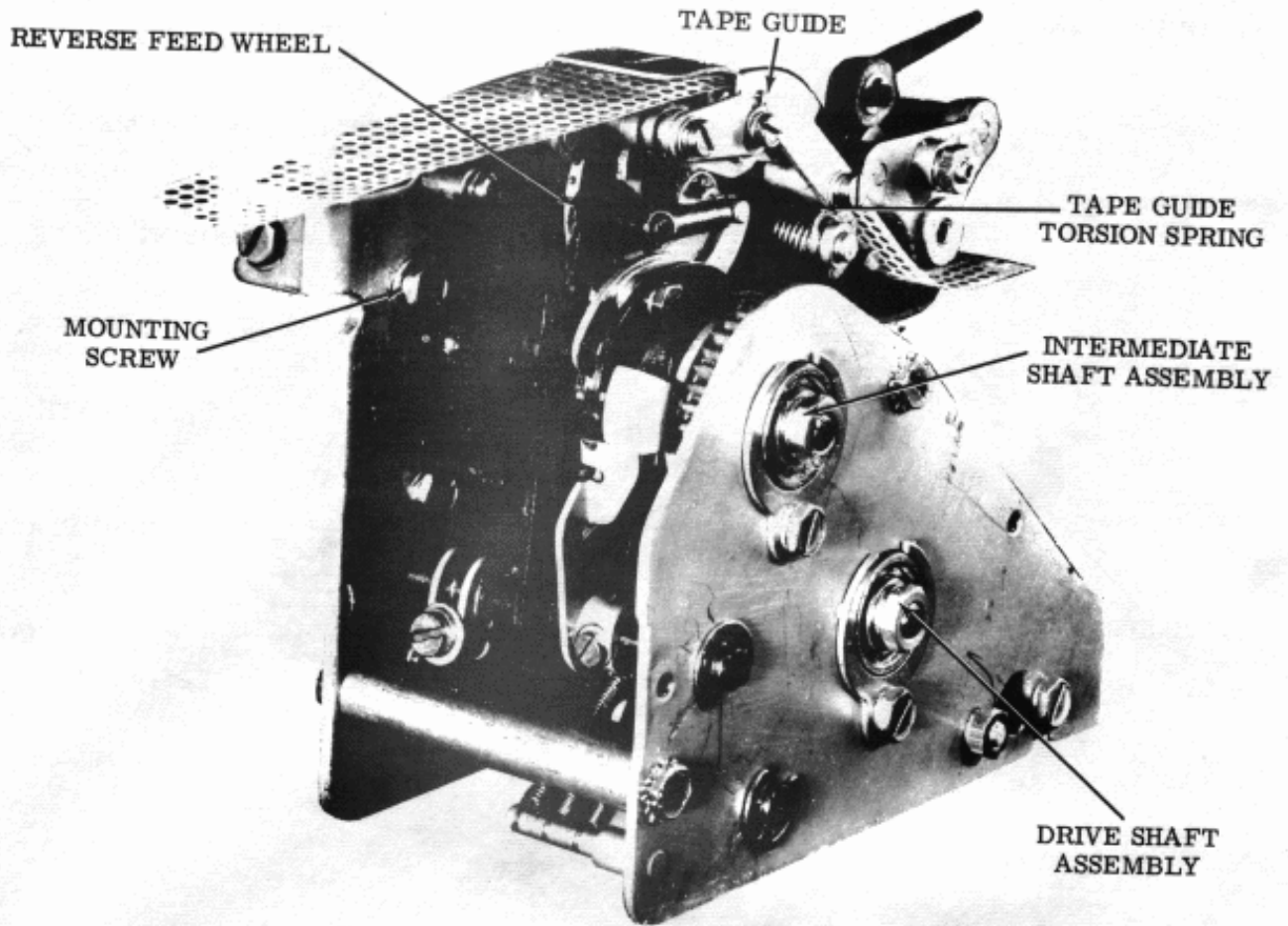

Figure 9 - Punch Backup Mechanism, Left Front Oblique

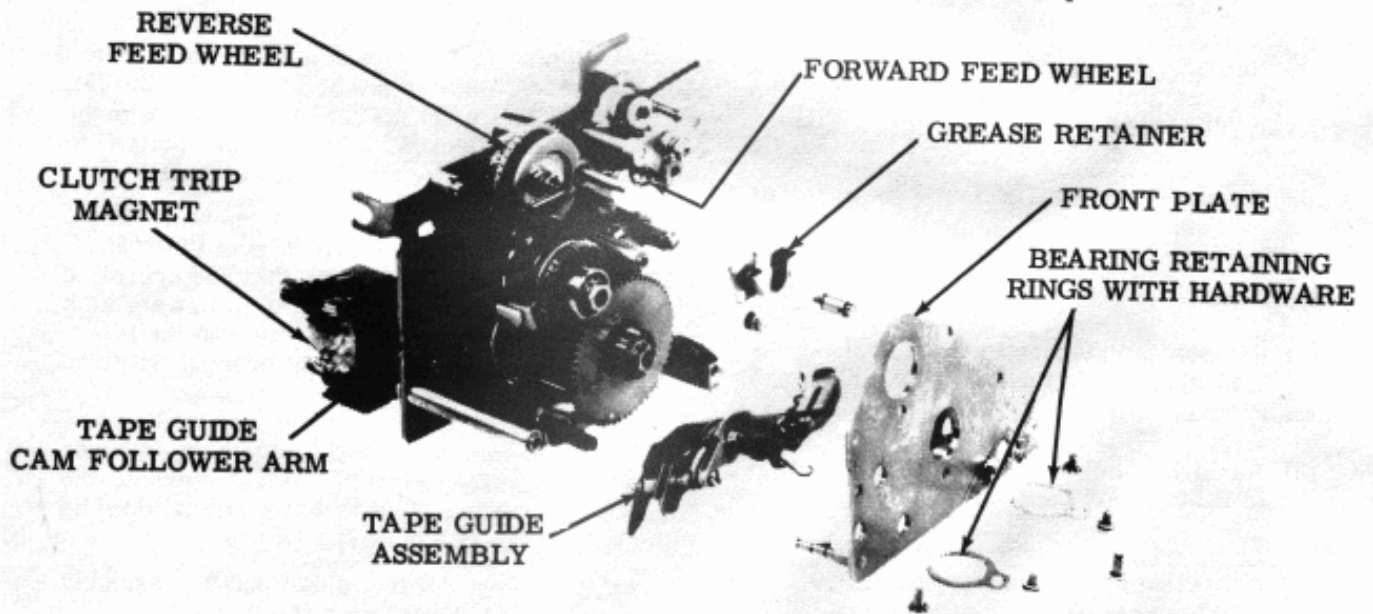

Figure 10 - Punch Backup Mechanism, Front Plate Removed

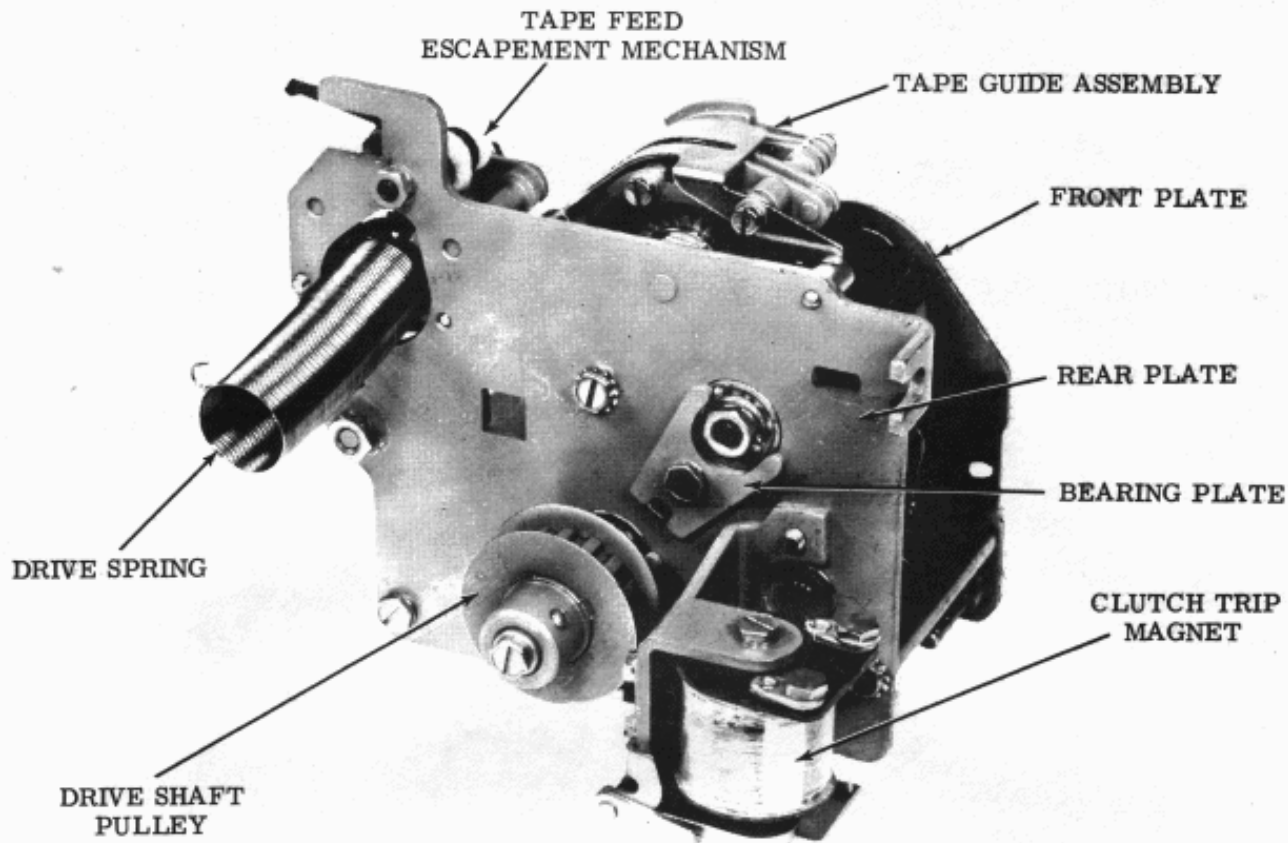

Figure 11 - Punch Backup Mechanism, Rear View

- (2) Remove the magnet assembly by sliding the armature bail (TP320370) out of the lever (TP320374).
- 3.10 To separate the front and rear plates (Figure 10):
- (1) Remove the detent lever spring (TP55669).
 - (2) Remove the magnet lever (TP320374) by loosening its clampscrew (TP151442) and sliding it off the shaft (TP320327).
 - (3) Remove the two bearing retainers (TP156588) on the front plate.
 - (4) On the front plate, remove the two screws (TP151630) and lockwashers (TP107116) that retain the front plate to the spacer posts (TP320308).
 - (5) On the rear plate (TP320304), remove the one screw and lockwasher that hold the tie bar (TP303032).
 - (6) While holding the clutch stop levers (TP320328), latchlevers (TP320329), and the detent lever (TP320331) away from the cams and clutches, pull the front plate forward to separate it from the rear plate.
- 3.11 To reassemble the front and rear plates, hold the tape lid switch lever (TP303034) slightly counterclockwise so that the operating post of the tape guide cam follower arm (TP320339) fits into the proper hole in the lever. Then, reverse the disassembly procedures given in 3.10.
- 3.12 To remove the tape guide cam follower arm assembly (TP320339), remove the retaining ring (TP119651) that secures it to the eccentric post (TP320338).
- 3.13 To remove the drive shaft assembly (TP320380) (Figure 10):
- (1) Remove the screw (TP151637) and lockwasher (TP3640) from the sleeve (TP320365) located at the pulley end of the shaft.

- (2) While holding the drive shaft assembly, remove the screw (TP151630) and lockwasher (TP2191) securing the bearing clamp (TP156619) and plate (TP156832) to the rear plate.
 - (3) Remove the drive shaft assembly.
- 3.14 To remove the intermediate shaft assembly (TP320378) (Figure 10):
- (1) While holding the intermediate shaft assembly, remove the screw (TP151630) and lockwasher (TP2191) securing the bearing clamp (TP156619) and plate (TP156832) to the rear plate.
 - (2) Remove the intermediate shaft assembly.
- 3.15 Remove the reverse feed wheel assembly by removing the retaining ring (TP119651) holding it on the pivot post.
- 3.16 To remove the drive spring (TP149833) (Figure 11):
- (1) Loosen the drive spring clampscrew located in the center of the drive spring.
 - (2) Remove the drive spring by sliding its formed end out of the hole in the clamp bushing (TP177883).