

HIGH SPEED TAPE PUNCH UNIT

(DRPE TYPE)

ADJUSTMENTS

CONTENTS	PAGE	CONTENTS	PAGE
1. GENERAL	2	Tape puller cam	16
2. BASIC UNIT	3	Tape puller contact pile-up	15
Punch Mechanism	3	Tape sensing arm spring	15
Armature (reed) clearance	5	Ten to the inch (final)	24
Bumper (silencing)	6	Ten to the inch (preliminary)	22
Link guide bracket	3	Tight-tape switch	17
No. 1 level reed position (early design) (except 5-level)	7	Wire sensing arm	17
No. 1 level reed position (late design) (except 5-level)	7	Yield spring	19
Punch block	4	3. VARIABLE FEATURES	29
Punch pin backstop	3	Photoelectric Reader (Verifier)	35
Punch pin penetration	10	Chad chute position	36
Reed position (early design)	8	Lamp focus	37
Reed position (late design)	9	Lamp position	38
Tape guide alignment	4	Mirror tube position	35
Tape Feed Mechanism	11	Punch Backup Mechanism	40
Antireversal disc position	11	Backup switch	46
Antireversal pawl spring	13	Backup switch actuating plate	45
Drive spring	18	Backup switch contact operation	46
Feed mechanism — vertical position	20	Clutch magnet armature	40
Feed wheel line-up	23	Clutch spring anchor plate (both clutches)	42
Idler arm gear mesh	11	Detent lever spring	60
Idler arm stop	13	Drive cam follower lever	41
Pressure roller spring	16	Drive shaft clutch latchlever spring	62
Ratchet and pawl escapement	18	Drive shaft clutch stop lever spring	62
Spring winder motor gear mesh	12	Drive spring	56
Spring winder switch	14	Feed mechanism — vertical position	57
Spring winder tension	13	Forward feed wheel	52
Suppressor roller	21	Intermediate shaft clutch stop lever spring	63
Tape bias spring (standard punch block)	22	Ratchet and pawl escapement	56
Tape guide clearance (final)	28	Reverse feed wheel	55
Tape guide clearance (preliminary)	19	Reverse feed wheel detent disc positioning	44
Tape guide punch block	21	Reverse feed wheel phasing	59
Tape guide spring	19	Tape edge guide (eleven-sixteenths inch tape) early design	48
Tape lid	19		
Tape-out switch (final)	27		
Tape-out switch (preliminary)	26		

CONTENTS	PAGE
Tape edge guide (eleven-sixteenths inch tape) late design	51
Tape edge guide (one inch) early design	47
Tape edge guide (one inch) late design	50
Tape edge guide (seven-eighths inch tape) early design	48
Tape edge guide (seven-eighths inch tape) late design	51
Tape guide cam follower arm spring	61
Tape guide (final)	54
Tape guide (preliminary) early design	47
Tape guide (preliminary) late design	49
Tape lid switch lever spring	61
Ten to the inch	58
Yield spring	60
 Universal Punch Block	 29
Adjustable tape guide	34
Latch bracket	30
Operating lever spring	31
Tape bias spring (universal punch block)	32
Tape guide biasing spring	31
Tape guide plate	30
Tape guide-roller position	33
Tape guide width	29

1. GENERAL

1.01 This section provides the adjusting procedures and illustrations for high speed punch units (DRPE type). It is reissued to incorporate recent engineering changes and to add the adjustments for the punch backup mechanism. Since it is a general revision, marginal arrows ordinarily used to indicate changes and additions are omitted.

1.02 Maintenance procedures which apply only to mechanisms of a particular design are so indicated in the appropriate places.

CAUTION: REMOVE POWER FROM UNIT BEFORE MAKING ADJUSTMENTS UNLESS OTHERWISE STATED.

1.03 The adjustments are arranged in a sequence that should be followed if a complete readjustment of the unit were under-

taken. In following such a procedure, parts or assemblies that are removed to facilitate adjustments should not be replaced until all other adjustments, which would be facilitated by removal of these parts, are made. If any adjustment is changed, related adjustments should be checked. Before making any adjustment, read the adjustment instructions thoroughly. After an adjustment is completed, be sure to tighten any nuts or screws which may have been loosened.

1.04 The spring tension values indicated are scale readings which would be obtained when proper scales are used as specified. Springs that do not meet the requirements, and for which no adjusting procedure is given, should be replaced by new springs.

1.05 Check all moving parts to make sure they are free from binds before operating the unit under power.

1.06 Parts ordering information can be obtained from Section 592-803-800TC. For the tools necessary in making the adjustments in this publication, refer to Section 570-005-800TC.

Note 1: Early design units may be equipped with solid reeds marked with an "X" on the end. Inspect the reeds, and if they have the "X", do not use the punch at speeds over 850 words per minute. If higher speeds are required, replace the solid reeds with the laminated type (not marked with an "X").

Note 2: Because the majority of applications of DRPE type punches are required to operate below 1500 words per minute, the factory product is now adjusted to, and tested at 1500 words per minute. For unit applications requiring 2400 words per minute operation, a suffix (/24) is added to the unit code contained in the identification plate starting with serial number 1753.

Example:

DRPE802 - denotes this unit is adjusted and tested for speeds up to 1500 words per minute.

DRPE802/24 - denotes this unit is adjusted and tested for speeds up to 2400 words per minute.

2. BASIC UNIT

2.01 Punch Mechanism

PUNCH PIN BACKSTOP

Requirement

Clearance between punch pin heads and backstop should be
Min 0.002 inch
gauge by eye.

To Adjust

With backstop mounting screws loosened, position backstop toward left. Tighten mounting screws.

Note: If punch block is removed from unit, backstop should be adjusted to retain punch pins.

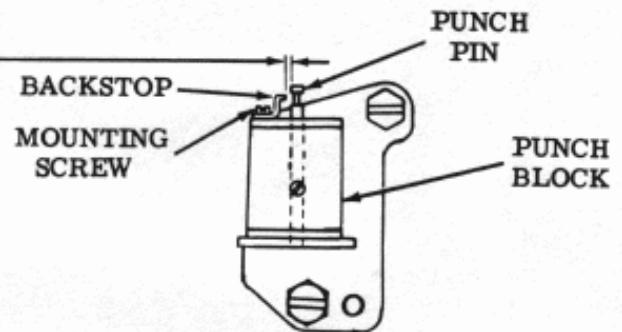

(Front View)

LINK GUIDE BRACKET

To Check

With punch block removed, remove feed and no. 7 magnet assemblies. Feed magnet is in lower right rear position; no. 7 magnet is in lower right front position.

Requirement

With long link pressed slightly against bottom of slots in link guide bracket, clearance between lower guidepost and long link with least clearance should be

Min some

To Adjust

Pre-position guide bracket so that it is centrally located in left mounting hole. (Washer TP8330 will provide approximately equal gap at both ends of elongated slot.) Check clearance between closest long link and lower guidepost to see if it meets requirement. If closest link is greater than 0.005 inch, adjust guide bracket toward right to meet requirement.

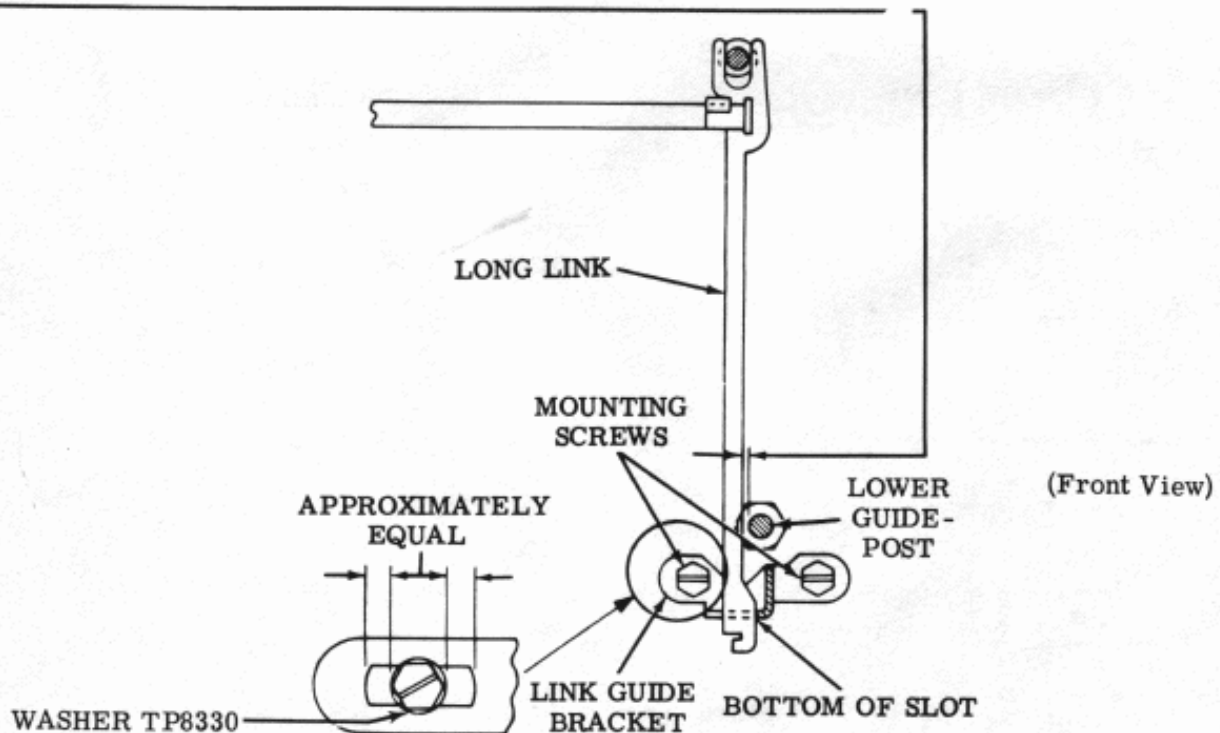

(Front View)

2.02 Punch Mechanism (continued)

PUNCH BLOCK**To Check**

With punch block assembled to unit, punch pins should move freely.

Note: Clearance should be checked at link guide bracket with links held against punch pins.

Requirement

With magnets removed from unit, or de-energized:

- (1) Clearance between closest link and guide bracket should be
Min some---Max 0.005 inch
- (2) Clearance between all other links and guide bracket should be
Min some---Max 0.012 inch

To Adjust

With punch block mounting screws and lower mounting screw (a nut is used in lower mounting position when photoelectric reader is used) loosened, pivot punch block about lower mounting screw to meet requirement. Tighten mounting screws.

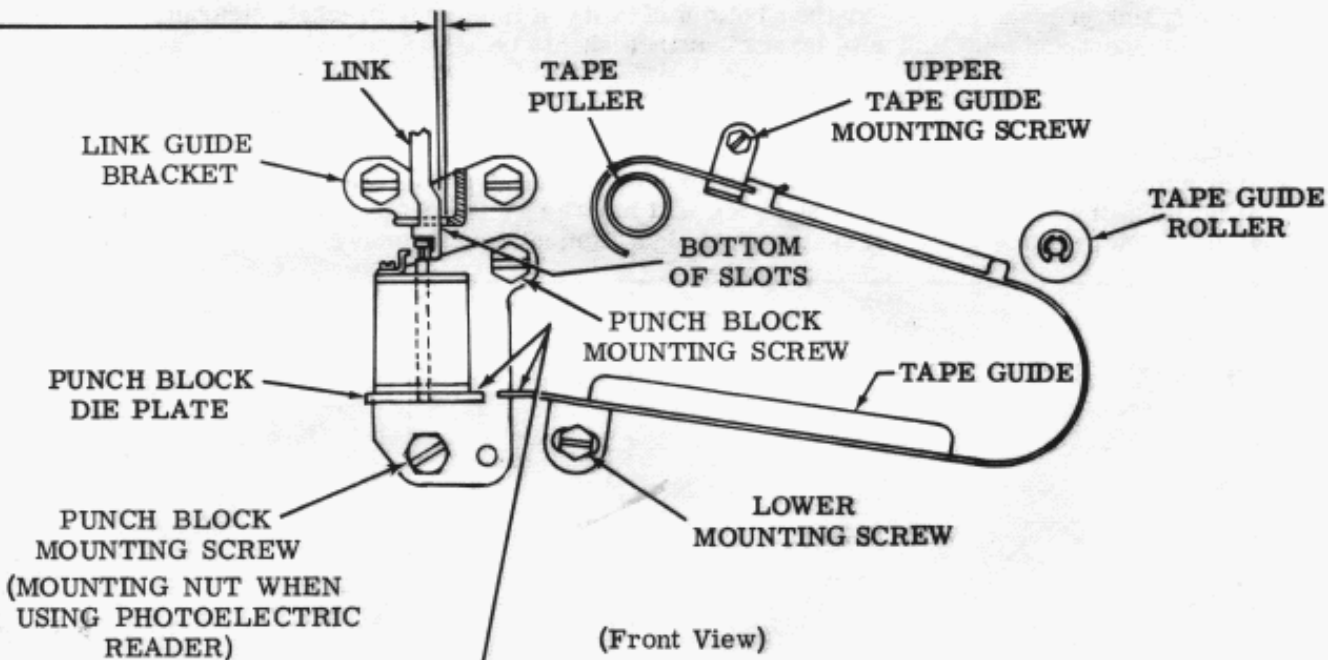
TAPE GUIDE ALIGNMENT**Requirement**

Top surface of tape guide should be aligned with top surface of punch block die plate extension as gauged by eye.

To Adjust

With lower mounting screw loosened, position tape guide to meet requirement. Tighten mounting screw.

2.03 Punch Mechanism (continued)

Note: This adjustment should be made with magnet bracket assemblies off unit and bumpers above pole face.

ARMATURE (REED) CLEARANCE

(1) Requirement

A 0.027 inch gauge should enter between pole face and reed from front (nearest reed tip) but should not enter from rear (nearest magnet).

(2) Requirement

An 0.008 inch gauge should enter between pole face and reed from front (nearest magnet) but should not enter from rear (nearest reed anchor).

To Adjust

With magnet mounting screws loosened, place gauge in center of pole face and rotate eccentric bushings to meet requirements. It is recommended that clearances between pole faces and reed be adjusted together. Note that eccentric highs should be toward outer edge of pole. Tighten magnet mounting screws and recheck requirements.

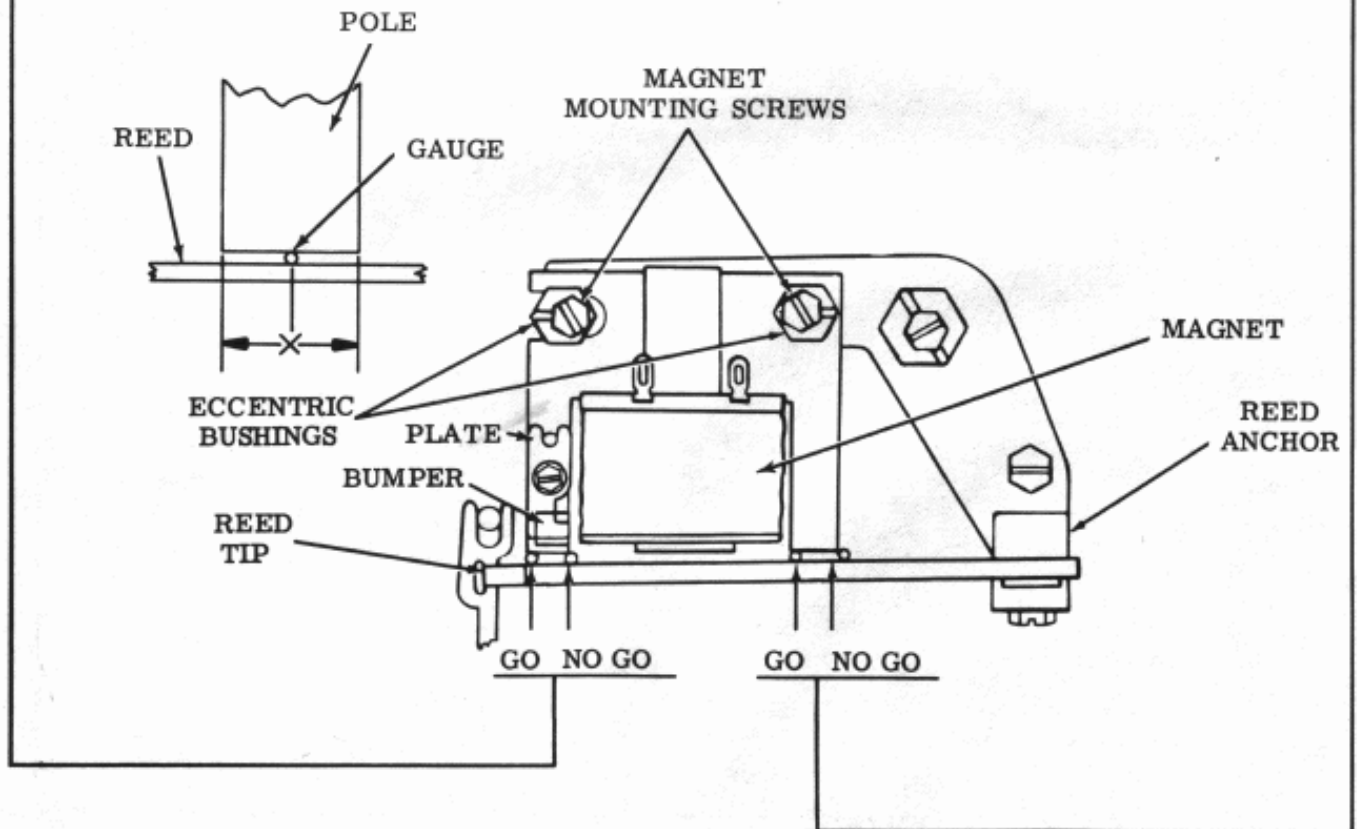

(Front View)

2.04 Punch Mechanism (continued)

BUMPER (SILENCING) (If Equipped)

Note 1: This adjustment should be made with magnet bracket assemblies off unit.

To Check

Make sure bumper is fully seated on its plate and reed mounting screws are tight.
Place a 0.010 inch gauge between bumper and pole face (nearest reed tip). Energize magnet and check bumper-reed clearance.

(1) Requirement

Clearance between reed and edge of bumper with least clearance should be
Min some (gauge by eye)---Max 0.005 inch

(2) Requirement

Clearance between bottom of bumper and pole face should be
Min 0.005 inch---Max 0.010 inch

(3) Requirement

With magnet energized with 2 amperes, it should not be possible to pass a
0.002 inch feeler gauge between pole and reed at point of least clearance.

Note 2: Number 6 or number 7 terminal leads may be used to obtain
 $\frac{2}{2}$ ampere potential for requirement (3).

To Adjust

With bumper plate mounting screw loosened, position bumper plate.
Tighten mounting screws and recheck requirements.

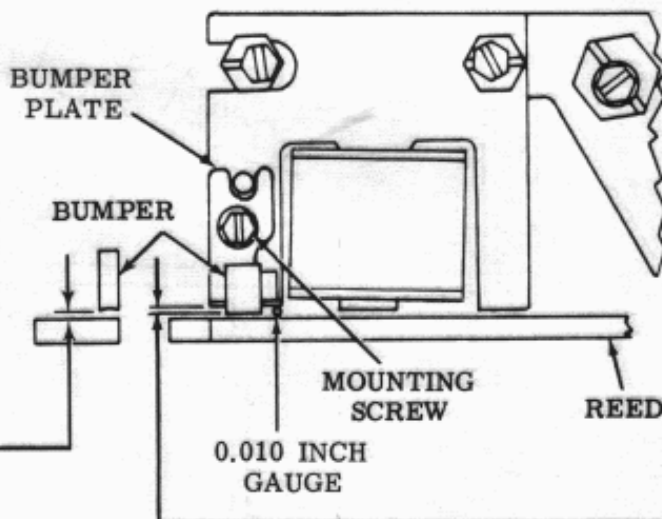

(Front View)

2.05 Punch Mechanism (continued)

NO. 1 LEVEL REED POSITION (EARLY DESIGN)
(EXCEPT 5-LEVEL)

Note: At this point, magnet assemblies should be assembled and adjusted in sequence to the punch. Sequence is as follows: no. 1, F, 4, 7, 8, 2, 3, 5, and 6 magnet assembly.

(1) Requirement

With play taken up between link and its guide (towards reed), clearance between side of no. 1 level reed tip and its link, and reed tip in full engagement with link should be

Min 0.012 inch

(2) Requirement

Clearance between no. 1 level reed and no. 2 level link should be

Min 0.005 inch---Max 0.015 inch

To Adjust

With reed mounting screws loosened, position reed. Tighten mounting screws.

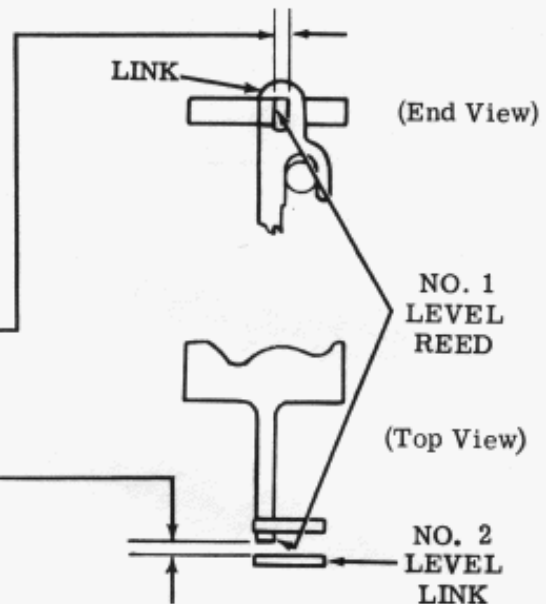
NO. 1 LEVEL REED POSITION (LATE DESIGN)
(EXCEPT 5-LEVEL)

Note: At this point, magnet assemblies should be assembled and adjusted in sequence to the punch. Sequence is as follows: no. 1, F, 4, 7, 8, 2, 3, 5, and 6 magnet assembly.

(1) Requirement

With play taken up between link and its guide (towards reed), clearance between no. 1 level reed tip and its link should be

Min 0.030 inch---Max 0.045 inch

(2) Requirement

Clearance between tip of no. 1 level reed and no. 2 link should be

Min 0.035 inch---Max 0.045 inch

To Adjust

With reed mounting screws loosened, position reed. Tighten mounting screws. Recheck requirement (1) of ARMATURE (REED) CLEARANCE (2.03) adjustment.

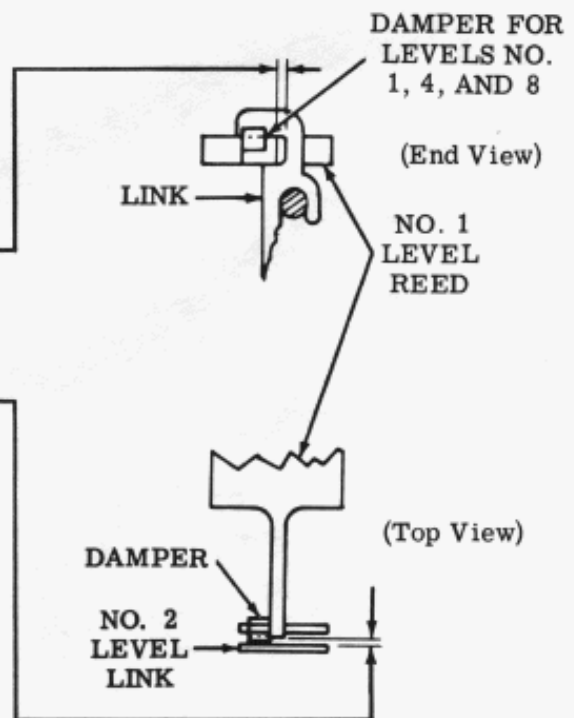

2.06 Punch Mechanism (continued)

REED POSITION (EARLY DESIGN)

(1) Requirement

Reed and link should be in full engagement when play between link and its guide is taken up toward reed with

Min 0.005 inch

between tip of reed and link.

(2) Requirement

Tip of reed should be centered in link as gauged by eye.

To Adjust

With reed mounting screws loosened, position reed. Tighten mounting screws.

Recheck requirement (1) of ARMATURE (REED) CLEARANCE (2.03) adjustment.

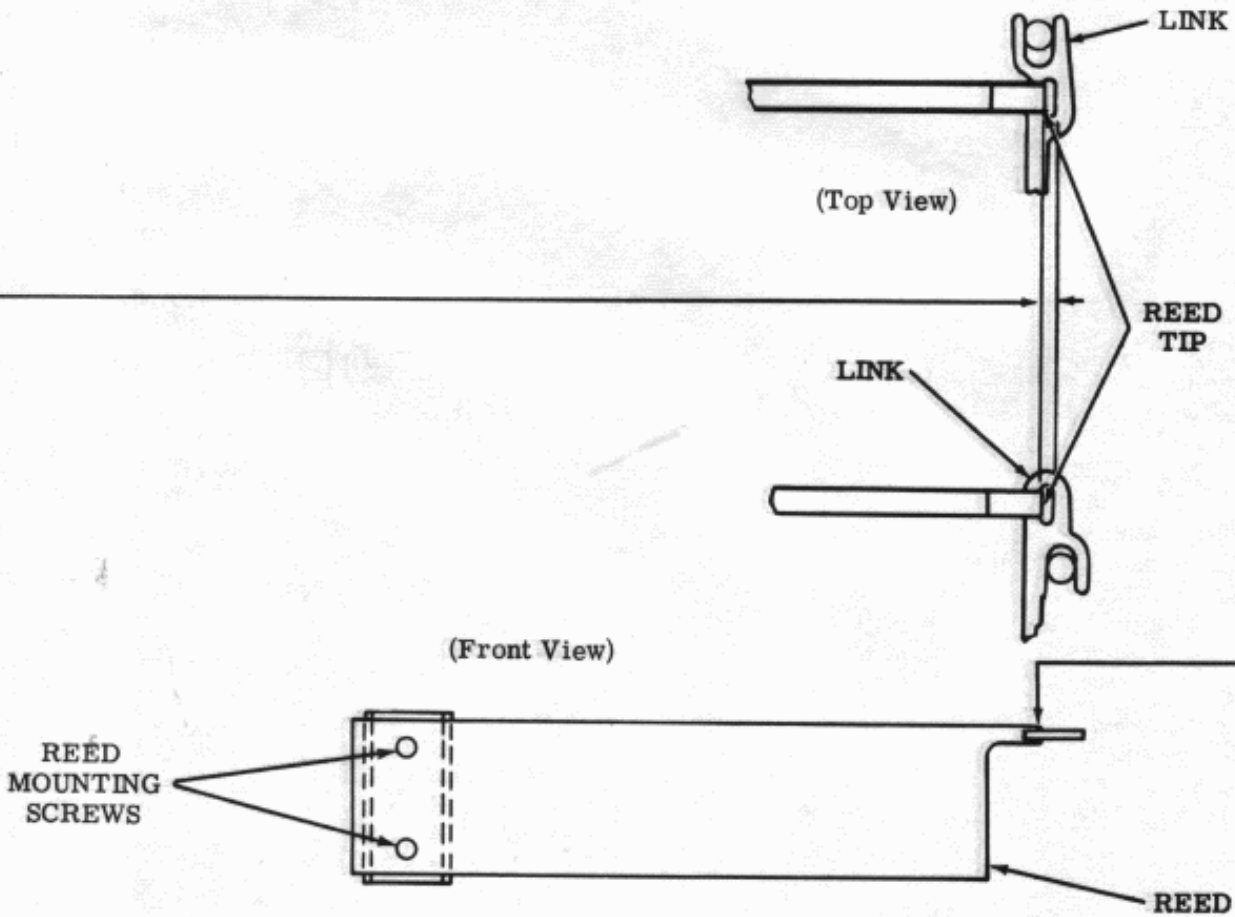

2.07 Punch Mechanism (continued)

REED POSITION (LATE DESIGN)

(1) Requirement

With play between link and its guide taken up toward reed, clearance between tip of reed and link should be

Min 0.030 inch---Max 0.045 inch

(2) Requirement

Tip of reed should be in full engagement with link, as gauged by eye, when punch pin penetration is adjusted

Approximately 0.006 inch below die plate.

To Adjust

With reed mounting screws loosened, position reed. Tighten mounting screws. Recheck requirement (1) of ARMATURE (REED) CLEARANCE (2.03) adjustment.

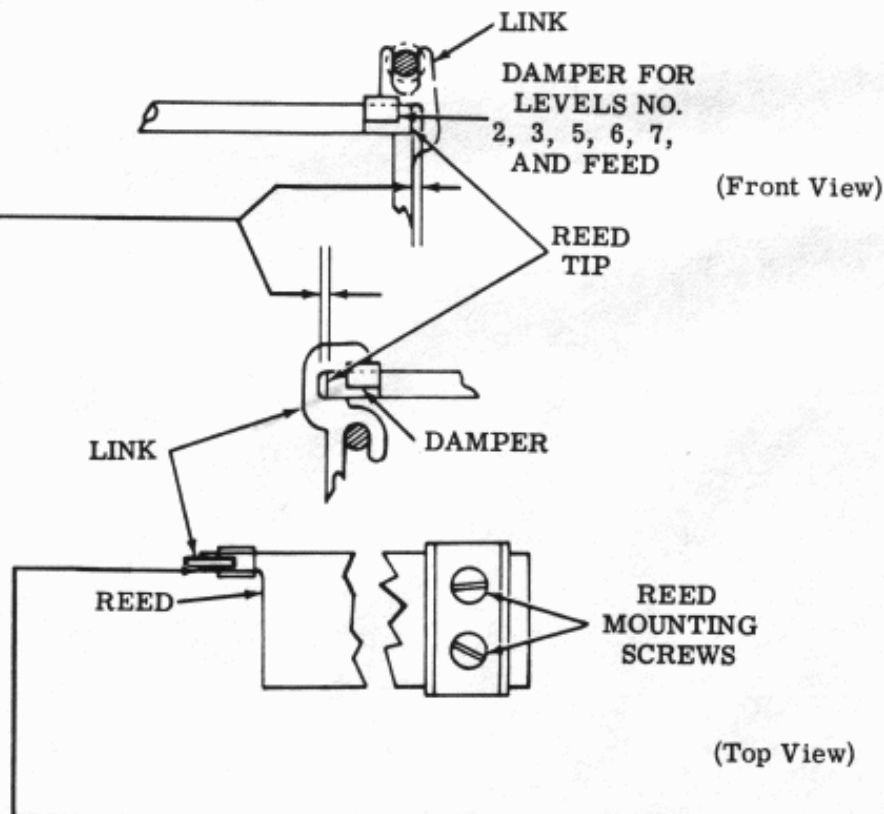

2.08 Punch Mechanism (continued)

PUNCH PIN PENETRATION

Note: DRPEs 1 and 2 (early design) use gauge TP148370. DRPEs 2 (late design) and 800 use gauge TP149902. All other DRPEs use gauge TP308373.

To Check

Make sure gauge is parallel with die plate projection and that gauge slides freely under punch pin heads. Check each pin starting with no. 1 pin.

Requirement

With reeds in neutral (unenergized) position, punch pins should just be entering die plate by
 DRPEs 1, 2, and 800---approx 0.013 inch
 all other DRPEs---approx 0.006 inch
 as gauged by eye.

To Adjust

With bracket mounting screws loosened, rotate eccentric bushing until under side of punch pin head just touches gauge. Tighten mounting screws. Check each pin, starting with no. 1 pin. Note that eccentric high is away from lower mounting screw.

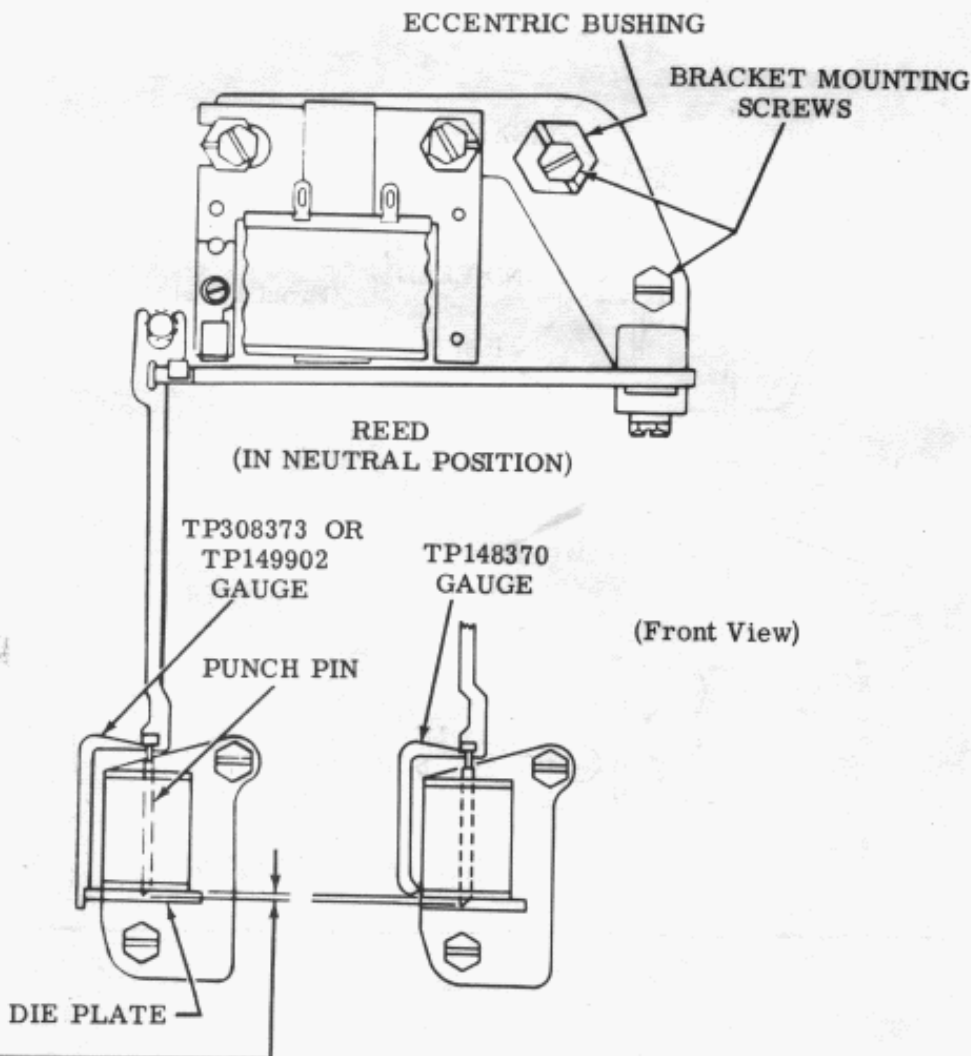

2.09 Tape Feed Mechanism

ANTIREVERSAL DISC POSITION

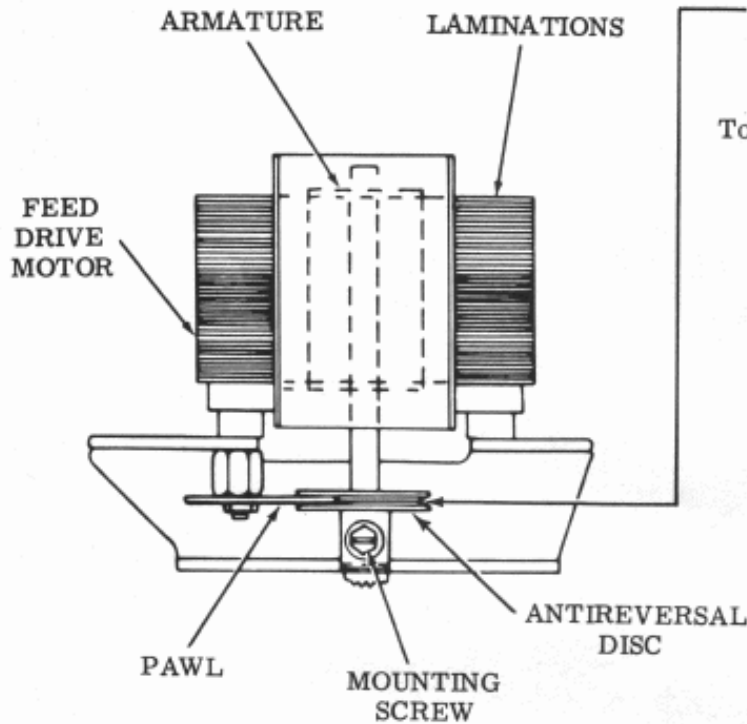

(Top View)

Requirement

With motor armature centered in laminations, pawl should be centered in slot in antireversal disc as gauged by eye.

To Adjust

With mounting screw loosened, position antireversal disc. Tighten mounting screw.

IDLER ARM GEAR MESH

Requirement

There should be a barely perceptible backlash between idler arm gear and spring sleeve gear with idler arm in position of least backlash.

To Adjust

With nut on idler arm eccentric pivot loosened, rotate eccentric to meet requirement. Note that eccentric high should be positioned up. Tighten nut.

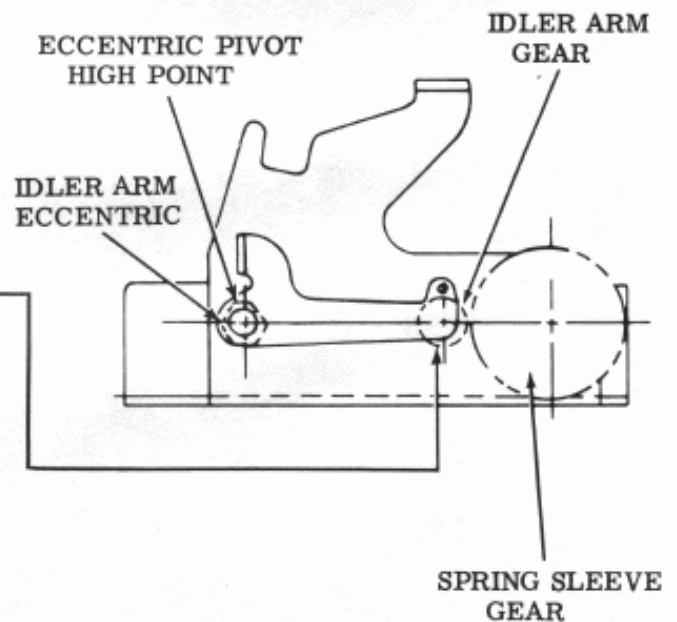

(Left Side View)

2.10 Tape Feed Mechanism (continued)

SPRING WINDER MOTOR GEAR MESH

Requirement

There should be a barely perceptible backlash between motor shaft gear and idler arm gear with idler arm in minimum backlash position.

To Adjust

With motor mounting nuts loosened, position motor. Tighten nuts.

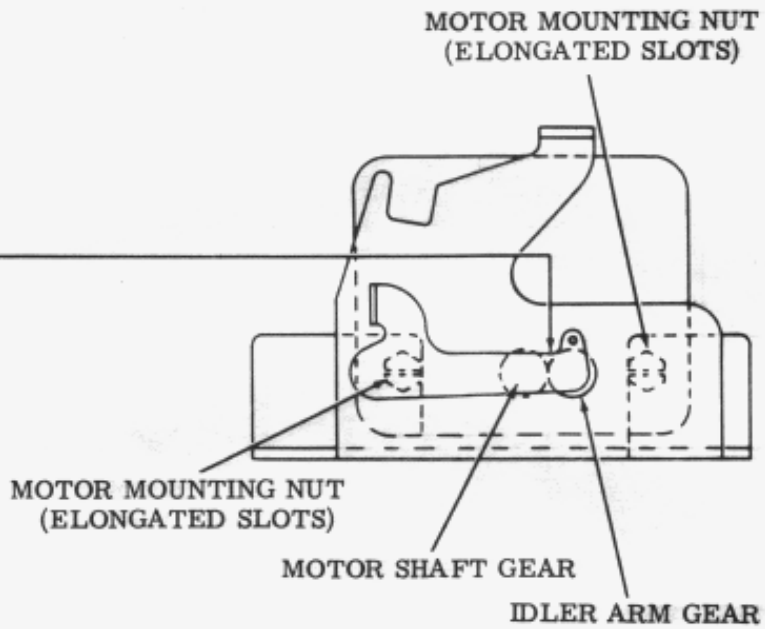

(Front View)

2.11 Tape Feed Mechanism (continued)

ANTIREVERSAL PAWL SPRING**To Check**

Unhook spring from pawl and pull to installed length with spring scale.

Requirement

Min 1/2 oz---Max 1-1/2 oz
to pull spring to installed length.

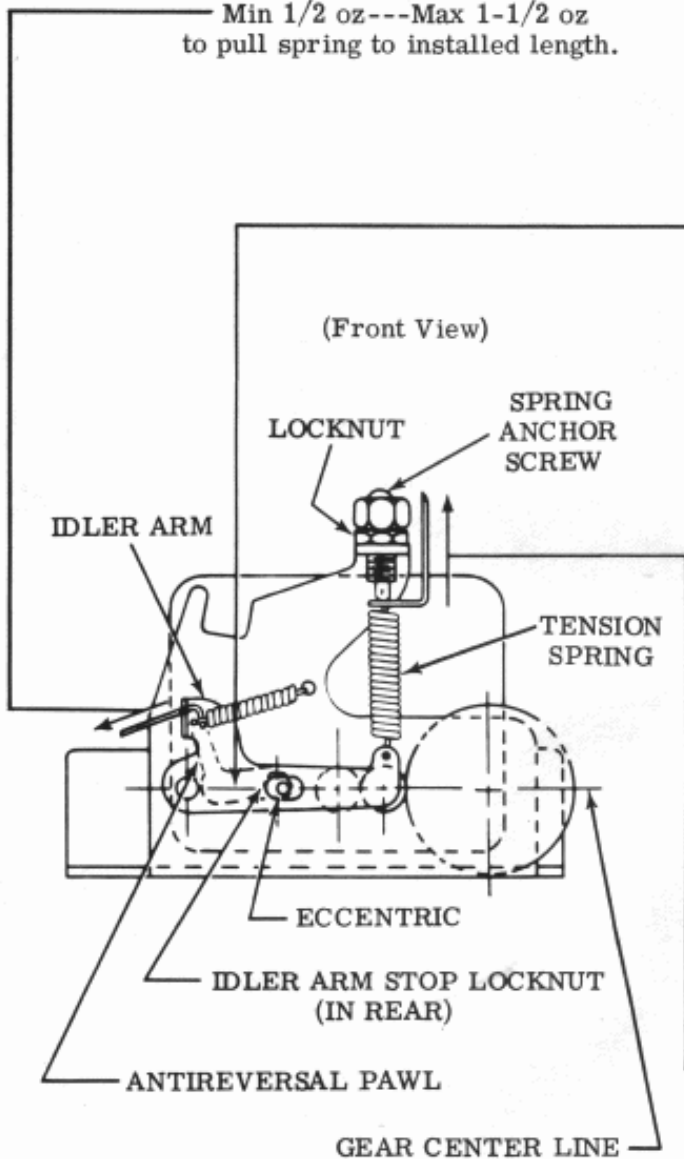
IDLER ARM STOP**Requirement**

Idler arm stop should stop idler arm an equal distance, above and below, center line of gears as gauged by eye.

To Adjust

With its locknut loosened, rotate stop. Note that eccentric high should be toward gears. Tighten locknut.

SPRING WINDER TENSION**To Check**

Spring winder tension should be measured with drive spring unwound.

CAUTION: IF TORQUE FROM A FULLY WOUND DRIVE SPRING IS SUDDENLY RELEASED, PERMANENT DAMAGE TO SPRING WILL RESULT. SPRING TENSION CAN BE RELEASED IN STEPS AT ANTIREVERSAL DISC PAWL (2.10).

Requirement

Units with silicon control rectifier switch (large)

Min 8 oz---Max 10 oz

Units with bidirectional switch (small)

Min 10 oz---Max 14 oz

to start tension spring moving.

To Adjust

Rotate spring anchor screw with its locknut loosened. Tighten locknut.

2.12 Tape Feed Mechanism (continued)

SPRING WINDER SWITCH

CAUTION: POWER MUST BE REMOVED FROM UNIT BEFORE THIS ADJUSTMENT IS CHECKED.

To Check

Operate switch by moving large gear by hand. This measurement must not be made by pressing on idler arm in vicinity of switch actuator. Correct operation of switch may be determined by audible click or by use of a continuity tester.

Requirement

Clearance between top of eccentric idler arm stop and slot in idler arm against which it stops when switch has just opened should be

Min 0.015 inch---Max 0.020 inch

(units with silicon control rectifier switch (large))

Min 0.010 inch---Max 0.016 inch

(units with bidirectional switch (small))

There should be some overtravel after switch has closed.

To Adjust

With switch bracket mounting screws loosened, position switch bracket by use of pry point. Tighten mounting screws.

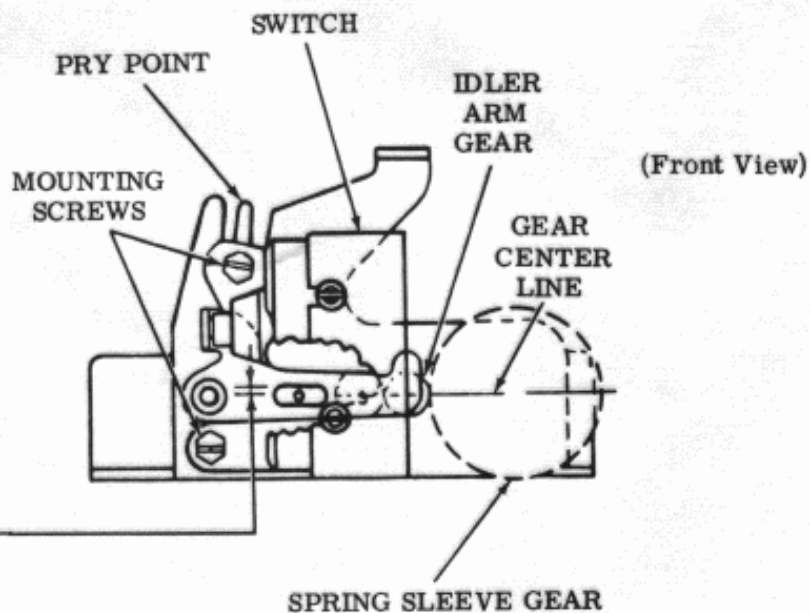

2.13 Tape Feed Mechanism (continued)

TAPE PULLER CONTACT PILE-UP

- (1) Requirement
Min 4 oz---Max 5 oz
to open contact.
- (2) Requirement
With contact swinger on high point
of puller cam, clearance between
contact points should be
Min 0.010 inch---Max 0.015 inch

- (1) To Adjust
Bend contact swinger to meet (1)
requirement.
- (2) To Adjust
With contact pile-up bracket
mounting screws loosened, position
contact pile-up, by use of pry point,
to meet (2) requirement. Tighten
mounting screws.

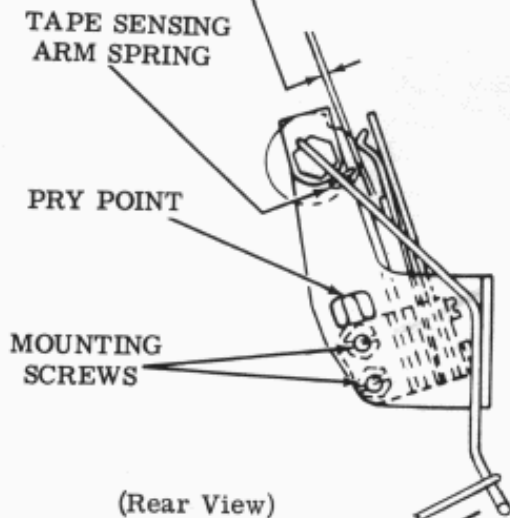
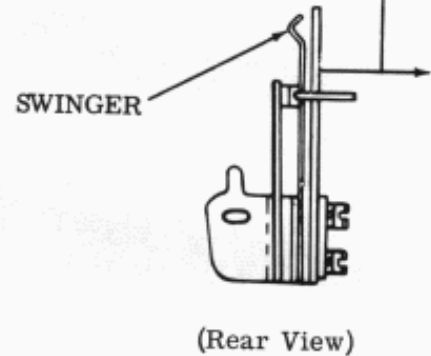

TAPE SENSING ARM SPRING

- Requirement
Min 10 grams---Max 21 grams
to start tape sensing arm moving away
from tape guide.

2.14 Tape Feed Mechanism (continued)

TAPE PULLER CAM

Requirement (Units not equipped with photoelectric reader)

Tape puller contacts should close when tip of wire sensing arm is

Min 1-1/4 inches---Max 1-1/2 inches

from tape guide, and should open when arm is moved beyond center of pressure roller.

Requirement (Units equipped with photoelectric reader)

Tape puller contacts should open when tip of sensing arm is 1/4 inch away from pressure roller.

To Adjust

With tape puller cam clamp nut loosened, rotate cam to meet requirement. Tighten clamp nut.

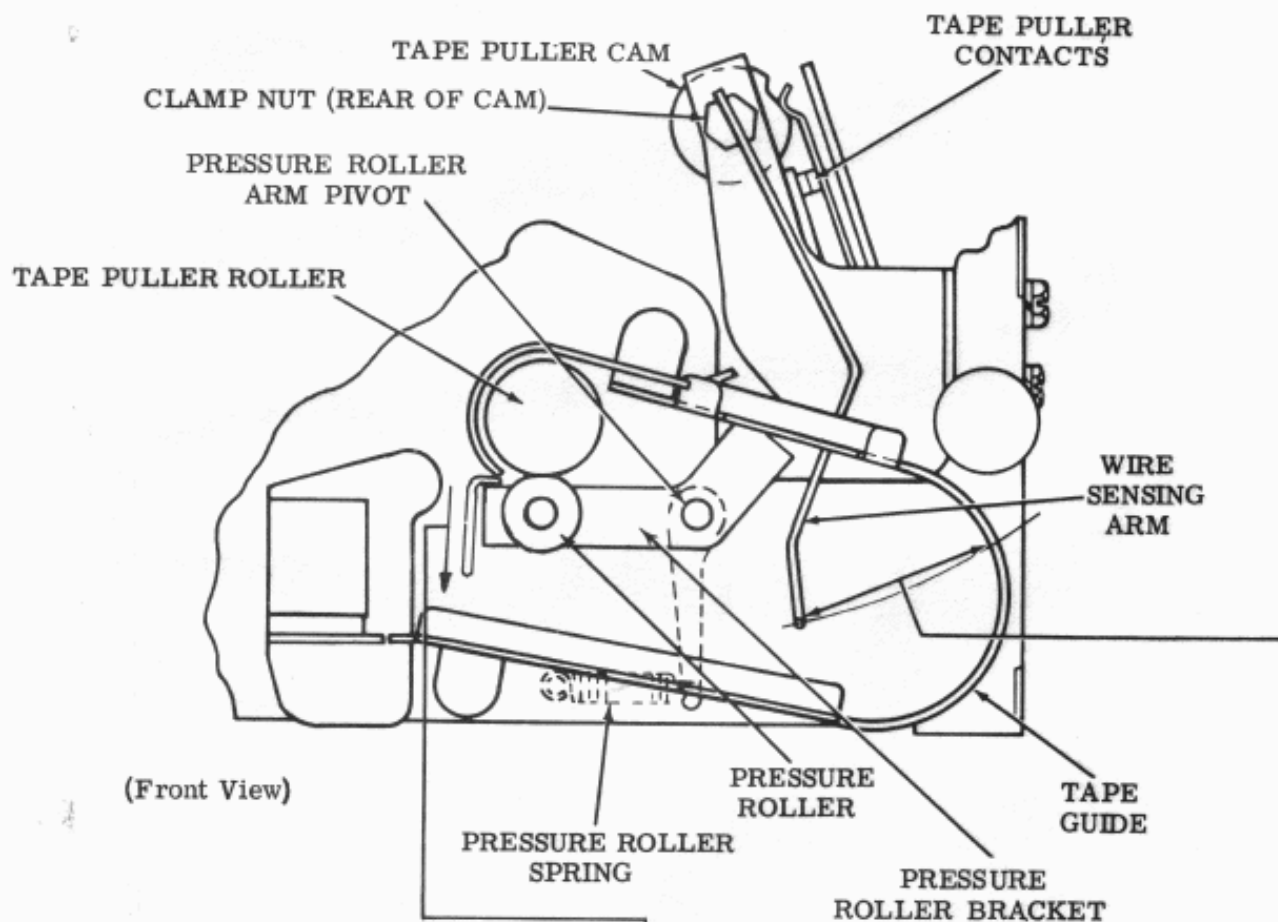

PRESSURE ROLLER SPRING

To Check

Hook an 8 oz spring scale over extensions of pressure roller bracket and pull at right angles to line joining pressure roller shaft and pressure roller arm pivot.

Requirement

Min 3 oz---Max 4 oz

to start pressure roller moving away from tape puller roller.

2.15 Tape Feed Mechanism (continued)

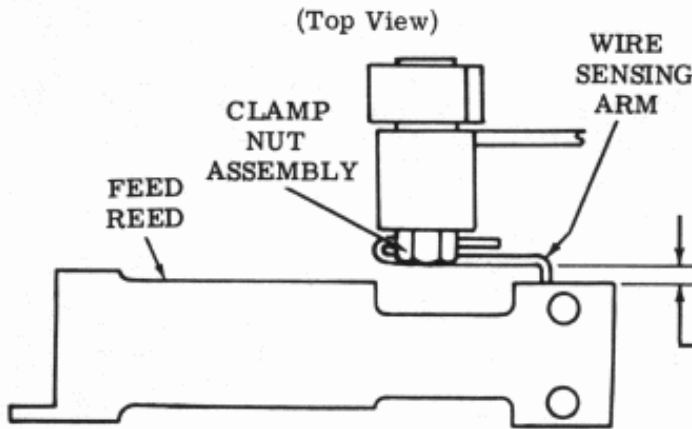

WIRE SENSING ARM

To Check
Actuate tape puller cam from off to on position.

Requirement
Clearance between feed reed and wire sensing arm should be
Min 1/16 inch
with play taken up to make clearance a minimum.

To Adjust
Form wire sensing arm.

TIGHT-TAPE SWITCH (If Equipped)

Note: This adjustment does not apply to units equipped with backup mechanism.

CAUTION: POWER MUST BE REMOVED FROM UNIT BEFORE THIS ADJUSTMENT IS CHECKED.

To Check
Correct operation of switch may be determined by audible click or by use of a continuity tester. Terminals (2) and (3), in illustration below, indicate contact closure.

Requirement
Tight-tape switch should operate when wire sensing arm reaches rim of tape puller pressure roller as gauged by eye.

To Adjust
With switch bracket mounting screws loosened, position switch bracket by use of pry point. Tighten screws.

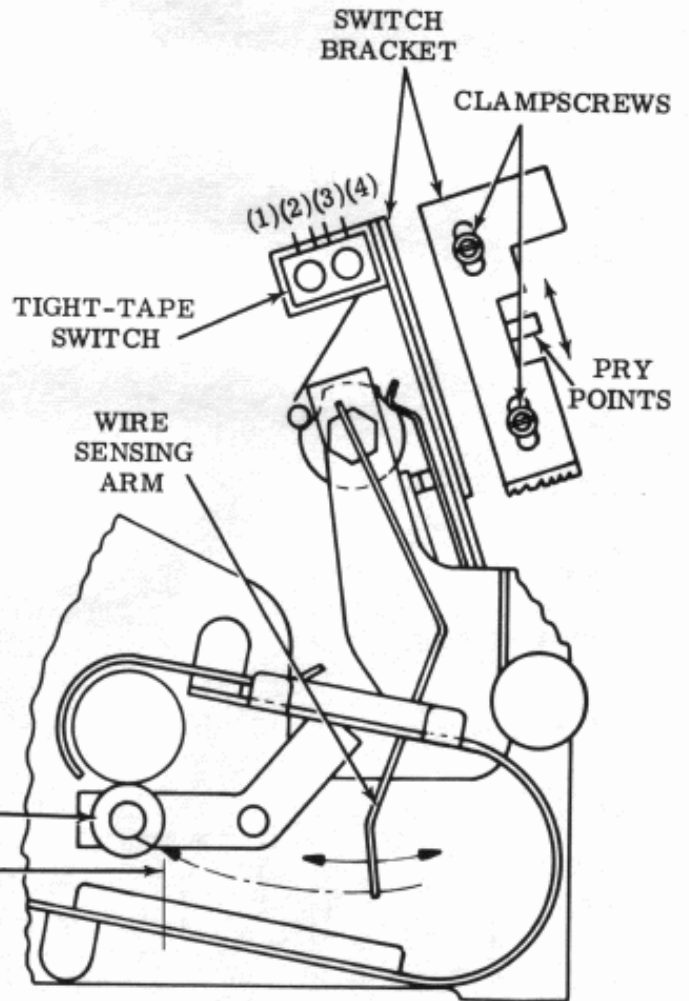

(Front View)

2.16 Tape Feed Mechanism (continued)

Note: The following adjustment must be made with feed mechanism and grease retainer removed from unit.

CAUTION: IF TORQUE FROM A FULLY WOUND DRIVE SPRING IS SUDDENLY RELEASED, PERMANENT DAMAGE TO SPRING WILL RESULT. SPRING TENSION CAN BE RELEASED IN STEPS AT ANTIREVERSAL DISC PAWL (2.10).

RATCHET AND PAWL ESCAPEMENT

(1) Requirement

With no torque applied to ratchet and pawl, and with ratchet and pawl operated by hand, ratchet should make equal steps on up stroke and on down stroke of pawl as gauged by eye.

(2) Requirement

It should not be possible for ratchet to move more than one step with pawl in any position.

(3) Requirement

With pawl raised, right pawl tooth should be opposite eighth (8) indent in upper half of ratchet.

To Adjust

With nut on eccentric pawl pivot post loosened, use a wrench or an Allen wrench to rotate eccentric, keeping eccentric high toward left. Tighten nut.

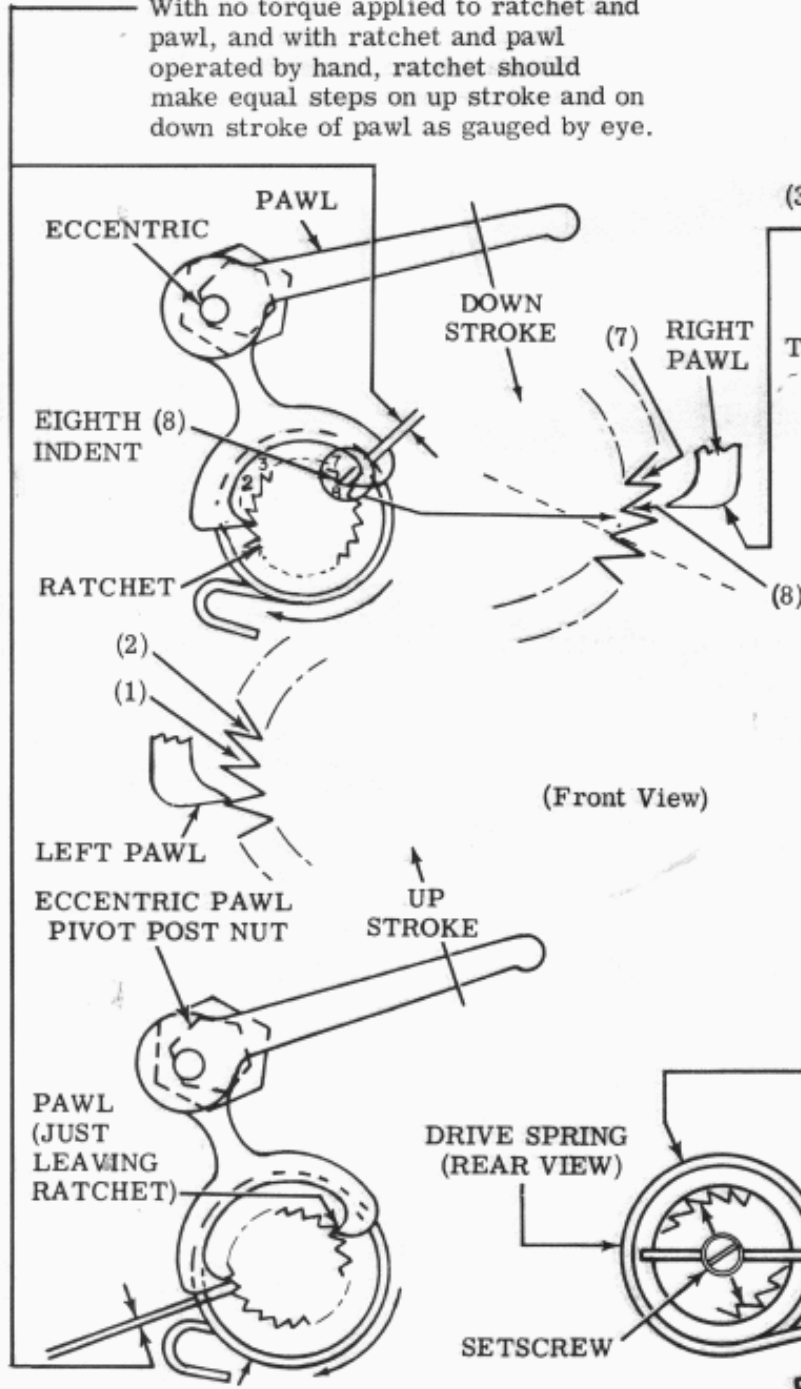

(Front View)

DRIVE SPRING

Requirement

Drive spring should be concentric with ratchet wheel.

To Adjust

With setscrew loosened, position spring. Hold feed wheel and tighten setscrew to 2 lb-in. with torque wrench.

2.17 Tape Feed Mechanism (continued)

TAPE GUIDE CLEARANCE (PRELIMINARY)

Note: This adjustment does not apply to units equipped with backup mechanism.

To Check

A round 0.006 inch gauge placed between two feed pins and tape guide should just touch high point on feed wheel. Check at least three points.

(1) Requirement

Clearance between tape guide and feed wheel measured at closest point with gauge conforming to feed wheel should be
Min 0.004 inch---Max 0.006 inch

(2) Requirement

With perforated tape (feed only) inserted between feed wheel and tape guide, pull tape toward right and at same time push tape guide handle toward eccentric stop. When tape is released, it should move freely toward left.

To Adjust

Loosen tape guide mounting bracket screws and eccentric stop bushing screw. Position tape guide bracket toward right or left using pry point and rotate eccentric stop bushing. Tighten screws.

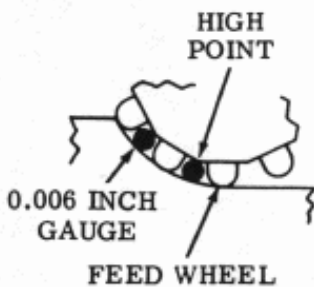

YIELD SPRING

Note 1: This adjustment does not apply to units equipped with backup mechanism.

Note 2: This spring tension should be checked with ratchet and feed wheel removed from unit. Hold ratchet and rotate feed wheel several times to assure bind free operation.

Requirement

With spring scale hook over a feed pin on feed wheel and pulling in a counterclockwise direction, it should require
Min 8 oz---Max 10 oz
to start feed wheel moving away from its stop.

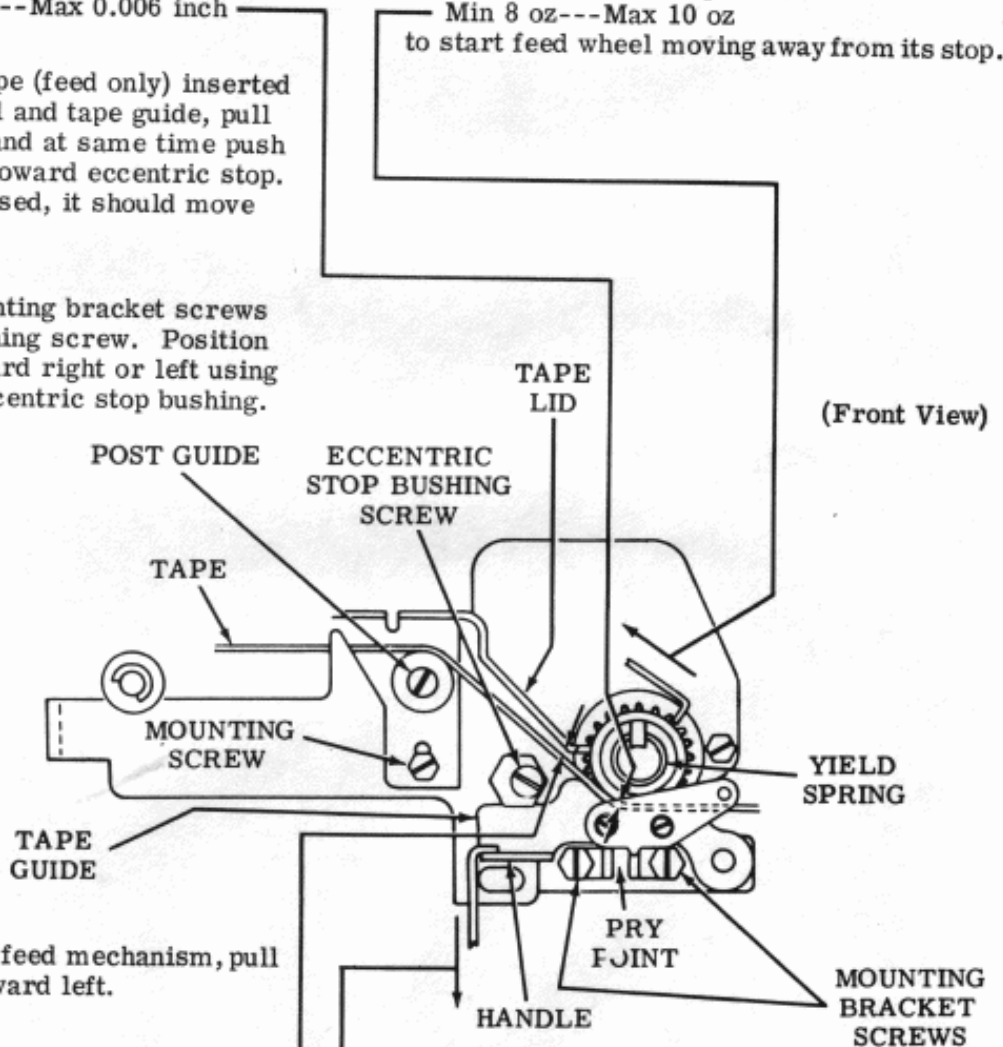

TAPE LID

To Check

With perforated tape in feed mechanism, pull tape over post guide toward left.

Requirement

Tape lid should be
Min 0.012 inch---Max 0.020 inch
above tape path.

To Adjust

With tape lid mounting screws loosened, position tape lid. Tighten screws.

TAPE GUIDE SPRING

Requirement

Min 7 oz---Max 9 oz
To start tape guide moving away from its stop.

2.18 Tape Feed Mechanism (continued)

FEED MECHANISM — VERTICAL POSITION

Note 1: This adjustment does not apply to units equipped with backup mechanism.

Note 2: Ratchet may fully unwind (slip) if reed magnets are de-energized and there is no tape in unit.

(1) To Check

With reed magnet de-energized and drive spring wound approximately two turns, apply light downward pressure on pawl, ratchet should step one tooth. Stepping may be determined by audible click of ratchet.

Note 3: If ratchet steps too fast (accelerated stepping) during To Check at two turns of drive spring, reduce amount of turns to eliminate accelerated stepping and enabling To Check stepping observation.

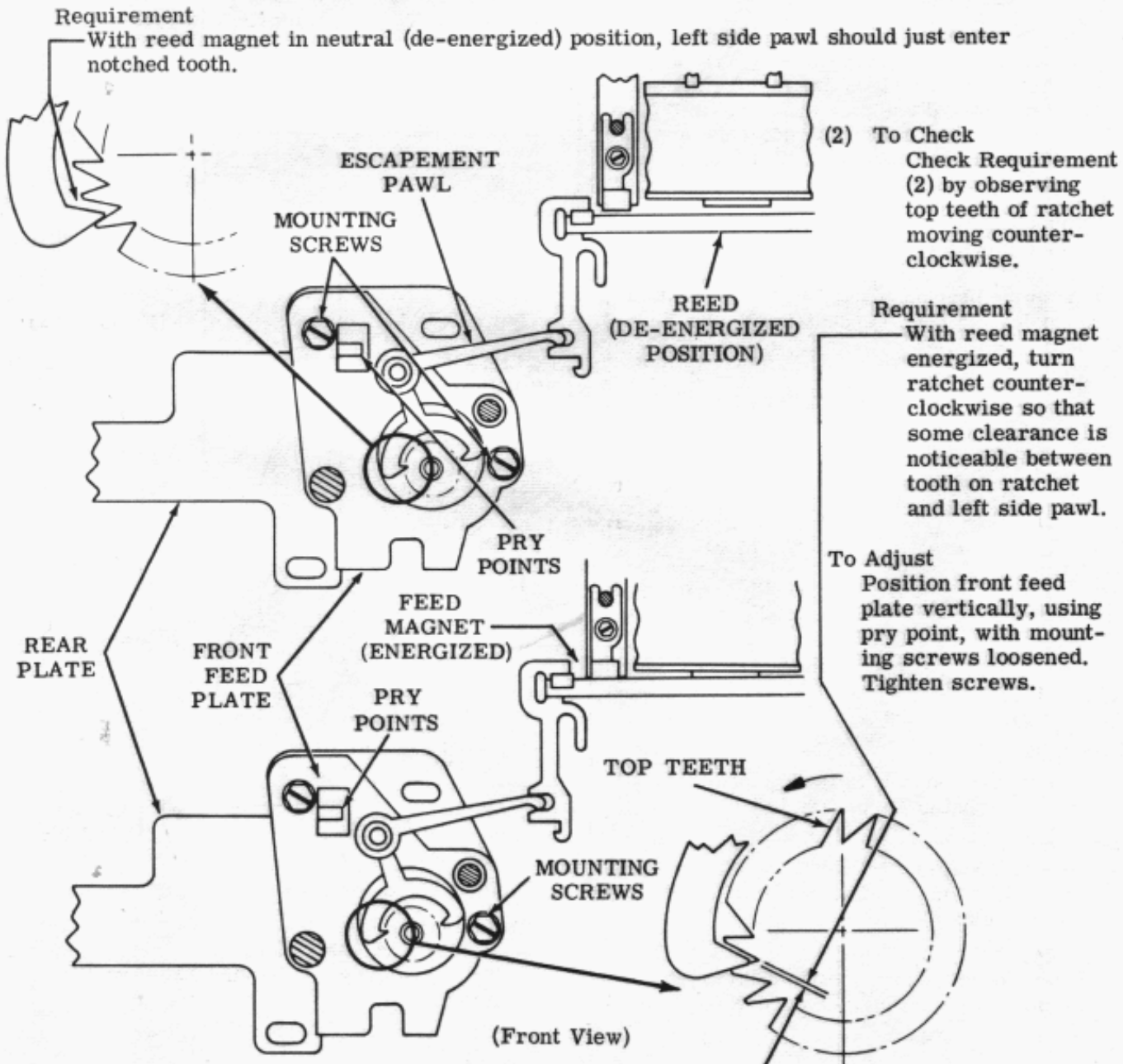

2.19 Tape Feed Mechanism (continued)

TAPE GUIDE PUNCH BLOCK

Note 1: This adjustment does not apply to units equipped with backup mechanism.

Requirement

Tape guide should align with die plate as gauged by eye.

To Adjust

With right mounting screw removed and left mounting screw loosened, pivot tape guide about left mounting screw. Replace right screw and tighten both mounting screws.

Note 2: If this requirement is not met, recheck TAPE GUIDE CLEARANCE (PRELIMINARY) (2.17) and TAPE LID (2.17) adjustments and refine if necessary.

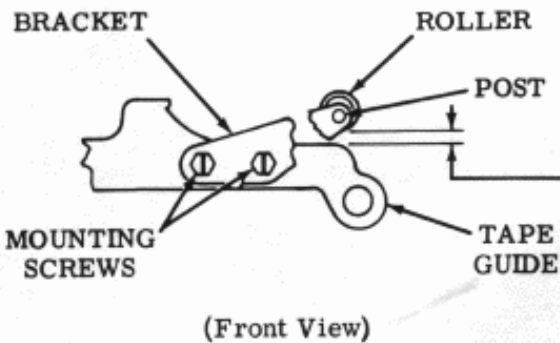
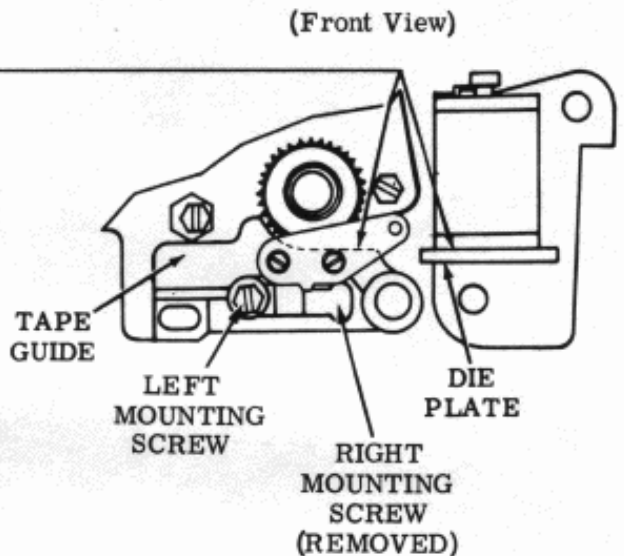

SUPPRESSOR ROLLER

Requirement

With blank tape inserted and feed hole perforated, clearance between roller inside diameter and post should be
Min 0.010 inch---Max 0.020 inch

To Adjust

Position bracket up or down with two mounting screws loosened. Tighten mounting screws.

2.20 Tape Feed Mechanism (continued)

TEN TO THE INCH (PRELIMINARY)

Note 1: This adjustment does not apply to units equipped with backup mechanism.

Requirement

With unit perforating tape and no levels marking, add one level marking at a time (in succession) until all levels are marking. Examine each perforated level in succession. Edges of holes in perforated tape should be clean cut and there should not be impressions or punch pin marks on spaces between holes.

To Adjust

Remove one of three feed mechanism mounting screws and center tapped hole in elongated slot as gauged by eye.

Note 2: If requirement is not met, recheck ARMATURE (REED) CLEARANCE (2.03), BUMPER (SILENCING) (2.04) and PUNCH PIN PENETRATION (2.08) adjustments and refine if necessary.

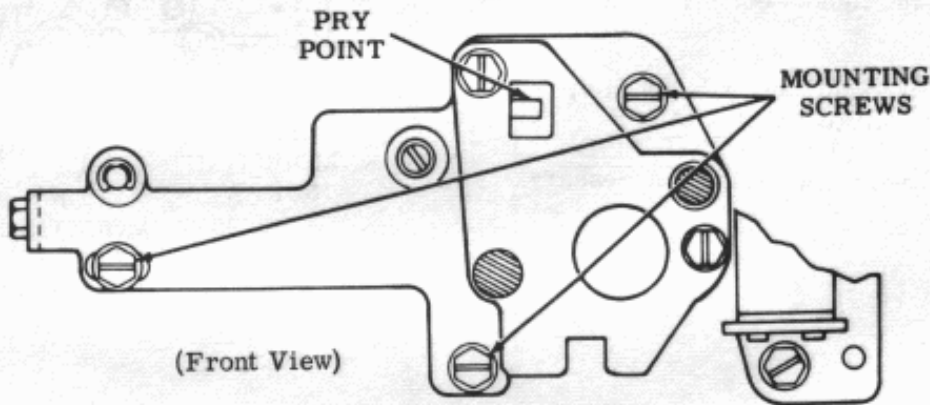

TAPE BIAS SPRING (STANDARD PUNCH BLOCK)

Note 1: This adjustment does not apply to units equipped with backup mechanism.

To Check

Perforate 3 or 4 feet of tape with all code levels marking. With one end of tape held at eye level, sight down tape. There should be no wavering in alignment of perforations with respect to edge of tape.

Requirement

Spring should bias tape towards rear of punch block without crimping or curling front edge of tape.

To Adjust

With mounting screws loosened, position bias spring. Tighten screws.

Note 2: Spring must not bind against lower guideplate or die plate.

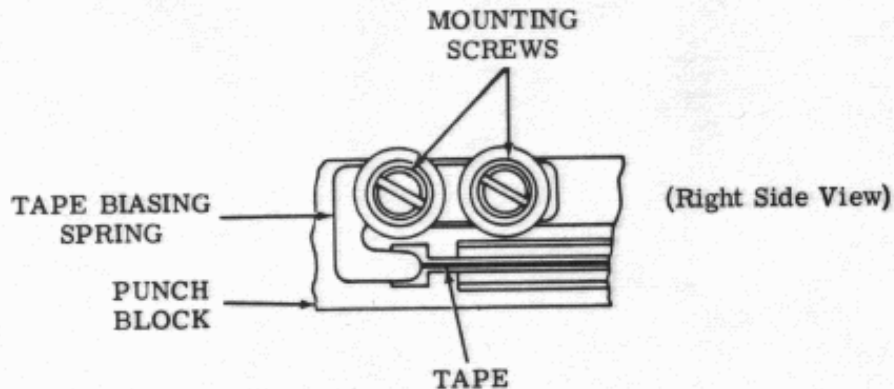

2.21 Tape Feed Mechanism (continued)

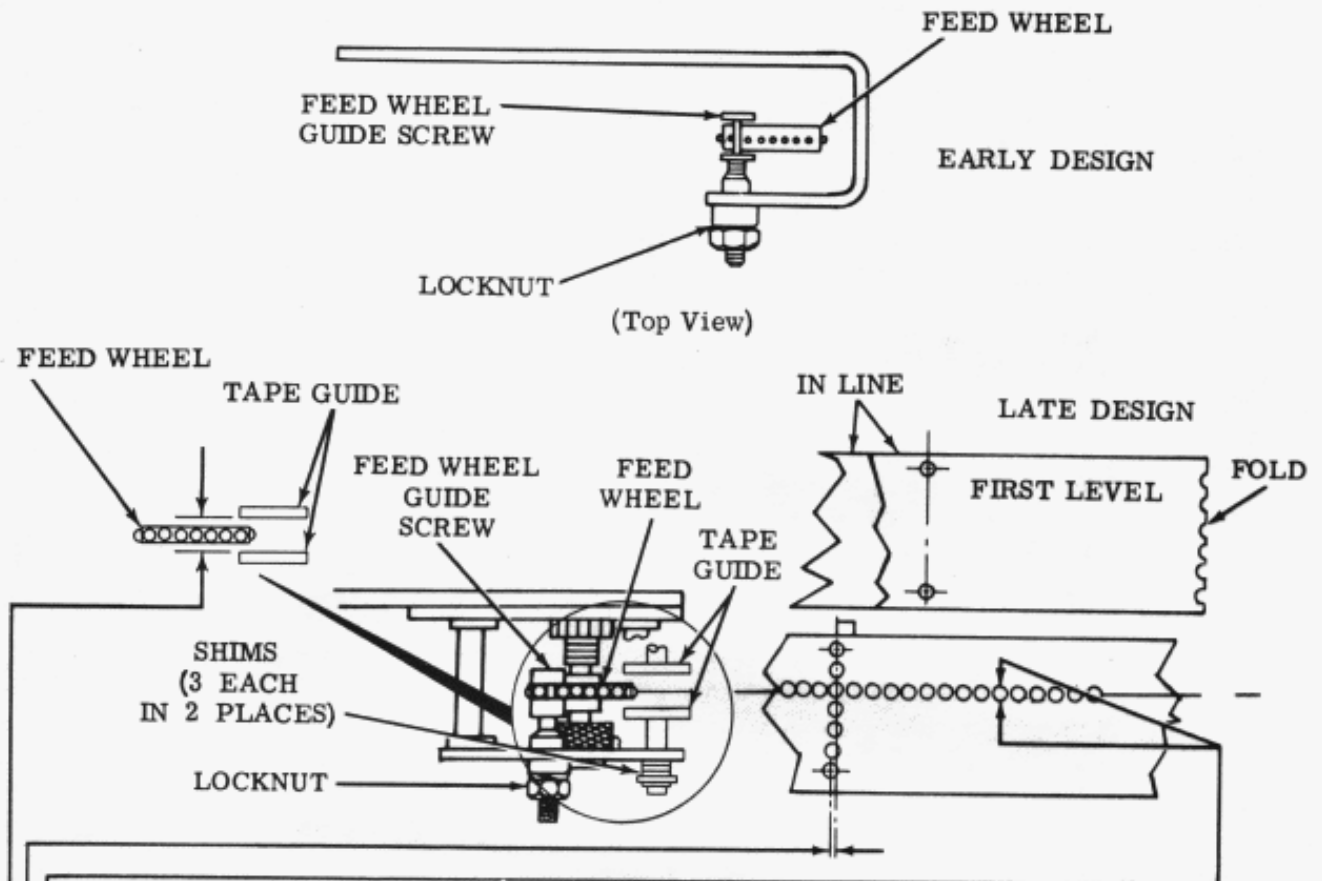
FEED WHEEL LINE-UP**To Check**

Perforate a length of tape at maximum unit speed and examine it for burrs. Fold tape with edges and first level in line. Fifth or eighth level holes (depending on unit level) should overlap as gauged by eye.

(1) Requirement

There should be no burr on front or rear edge of feed hole when tape is perforated at maximum unit speed.

(2) Requirement

With unit perforating tape at maximum speed, hole centers should be square to tape edge within

± 0.003 inch

To Adjust

With feed wheel guide screw locknut loosened, rotate screw using an Allen wrench. Tighten locknut.

(3) Requirement

Feed wheel should be centered between tape guide as gauged by eye.

To Adjust

Center tape guide by removing shims from one side of hub and adding to other side of hub until feed wheel/tape guide is centered. A total of six shims must be contained on each assembly after centering is completed.

2.22 Tape Feed Mechanism (continued)

TEN TO THE INCH (FINAL)

Note: Tape gauge TP302990 replaces tape gauge TP95960. First five holes in gauge TP302990 are same size as code holes in tape (0.072 inch diameter). Sixth hole in gauge is larger than first five (0.102 inch diameter). This arrangement allows a ± 0.015 inch variation in ten to the inch spacing over five inches. Gauge TP95960 allowed a ± 0.007 inch variation in ten to the inch spacing over five inches.

To Check

Perforate a length of tape, at least 5 inches long, with all levels marking. Place tape over smooth side of tape gauge TP302990 so that first number two code hole in tape is concentric with first hole (0.072 inch diameter) of tape gauge. Next four holes (0.072 inch diameter) in tape gauge should be visible through number two code holes in tape. Last number two code hole in tape should be entirely within sixth hole (0.102 inch diameter) in tape gauge. Favor short ten to the inch spacing at 1200 words per minute and long at 2400 words per minute (within gauge).

Requirement

Tape punch should produce tape that conforms to tape gauge TP302990 at 1200, 2000, and 2400 words per minute.

To Adjust

Loosen three mounting screws that fasten feed mechanism to main casting. Rotate adjusting screw clockwise to move feed mechanism toward right or counterclockwise to move feed mechanism toward left until requirement is met. If ten to the inch spacing is short, feed mechanism should be moved toward left. If spacing is too long, it should be moved toward right. Tighten mounting screws and recheck FEED MECHANISM — VERTICAL POSITION (2.18) adjustment and refine if necessary. Recheck TEN TO THE INCH (FINAL) adjustment and refine if necessary.

2.23 Tape Feed Mechanism (continued)

TEN TO THE INCH (FINAL) (continued)

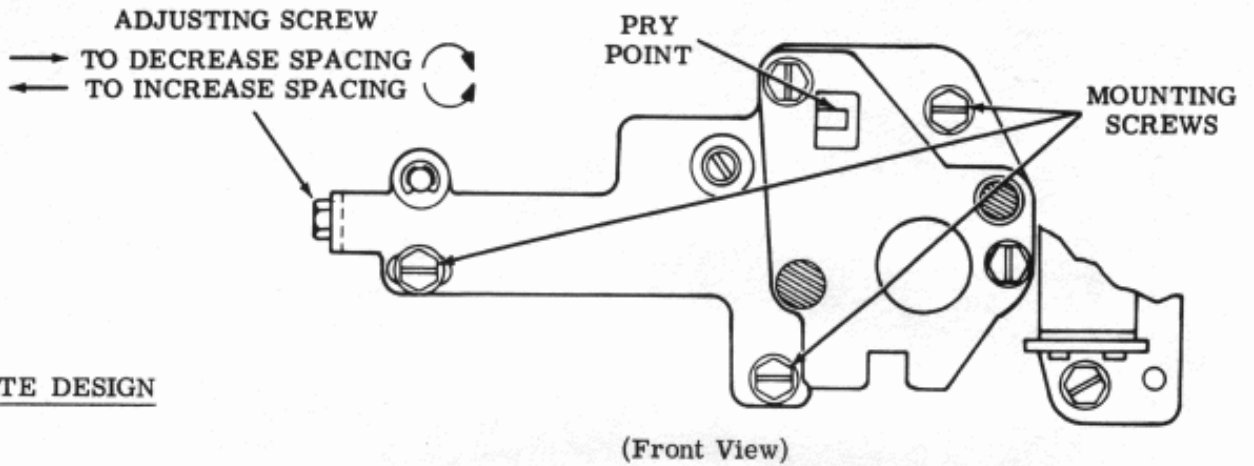

LATE DESIGN

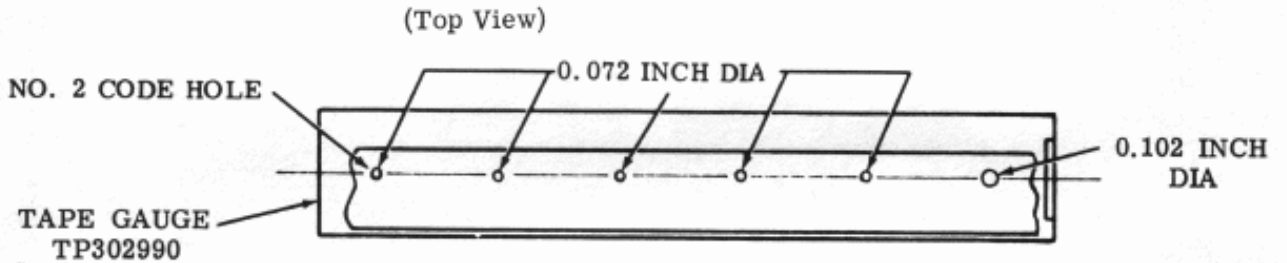

EARLY DESIGN

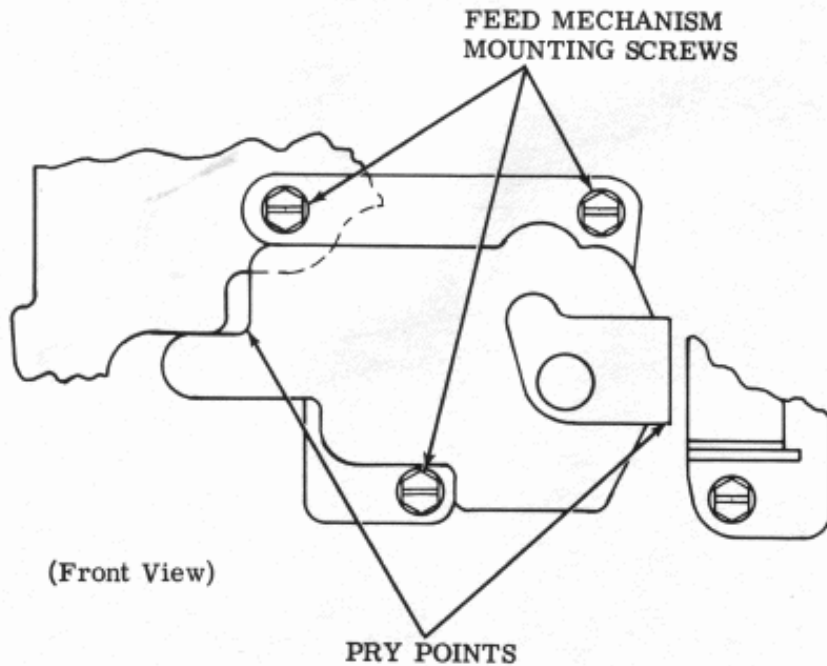

2.24 Tape Feed Mechanism (continued)

TAPE-OUT SWITCH (PRELIMINARY) (If Equipped)

Note: This adjustment does not apply to units equipped with backup mechanism.

To Check

Operation of switch may be determined by audible click of switch or by use of a continuity tester.

Requirement

With tape in tape guide, clearance between tape-out switch roller and tape should be

— Min 0.012 inch---Max 0.020 inch
when switch has just opened.

To Adjust

With tape-out switch mounting screws loosened, pivot switch around left mounting screw to meet requirement. Tighten screws.

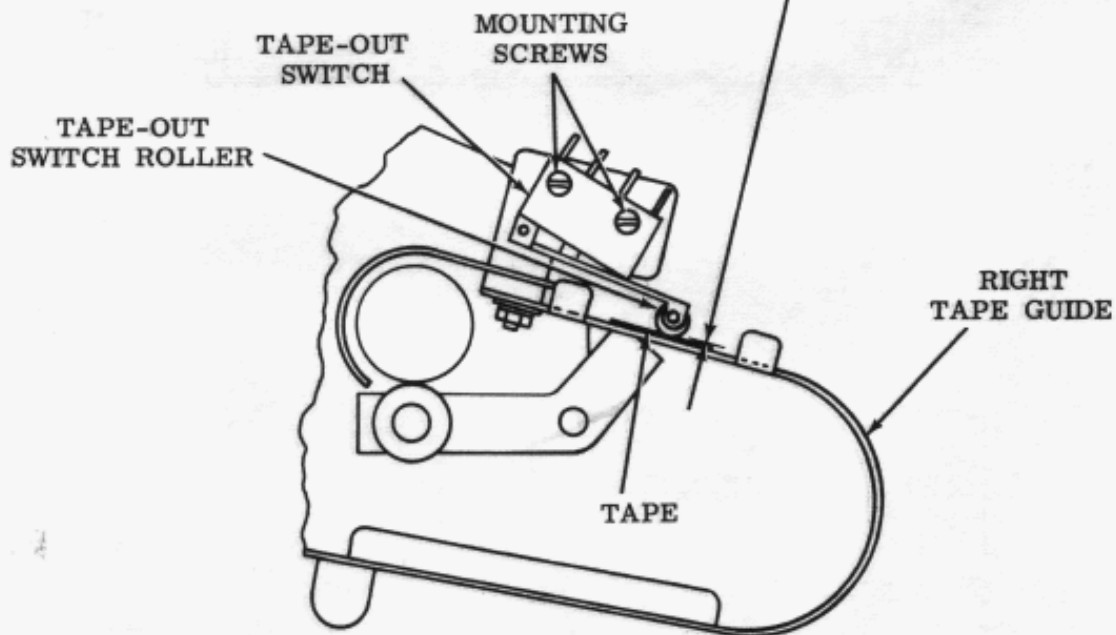

(Front View)

2.25 Tape Feed Mechanism (continued)

TAPE-OUT SWITCH (FINAL) (If Equipped)

Note: This adjustment does not apply to units equipped with backup mechanism.

Requirement

Tape-out switch should be centered between feed reed and no. 7 code level reed as gauged by eye.

To Adjust

Loosen switch bracket mounting nuts and position switch bracket. Tighten nuts.

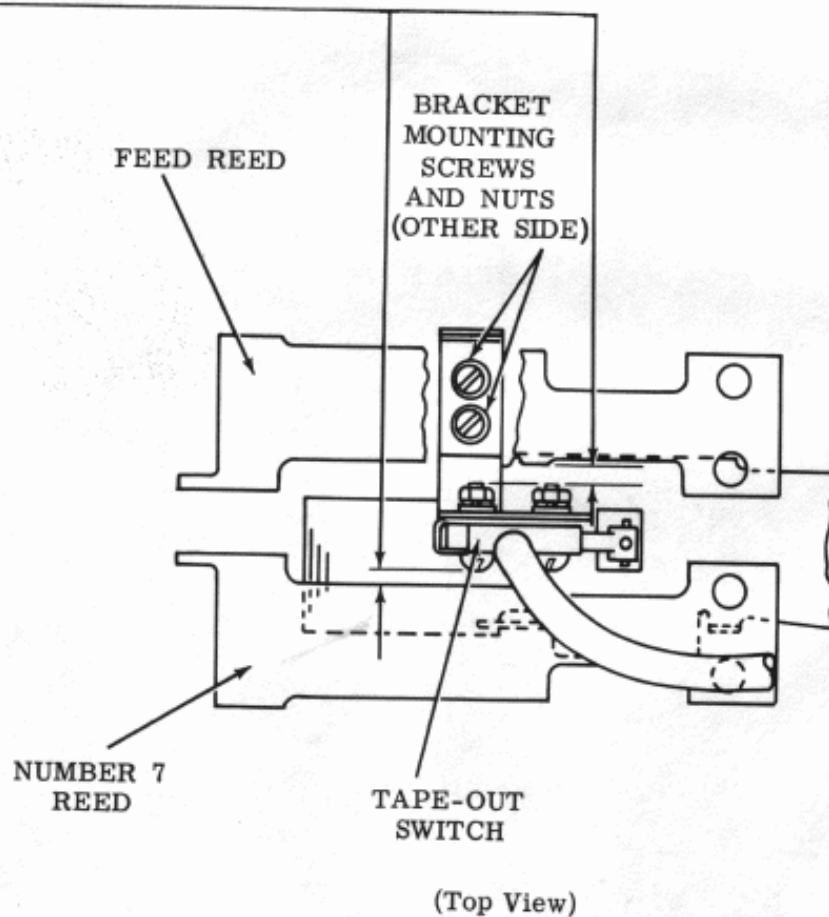

2.26 Tape Feed Mechanism (continued)

TAPE GUIDE CLEARANCE (FINAL)

Note: This adjustment does not apply to units equipped with backup mechanism.

To Check

Apply 6 oz to 8 oz pressure, at center of tape guide handle, toward eccentric stop.

Requirement

With punch operating at maximum operating speed, punching feed and no. 7 level only, tape produced should meet ten to the inch requirement with or without applying pressure to tape guide handle.

To Adjust

If requirement is not met, check and refine TAPE GUIDE CLEARANCE (PRELIMINARY) (2.17) adjustment.

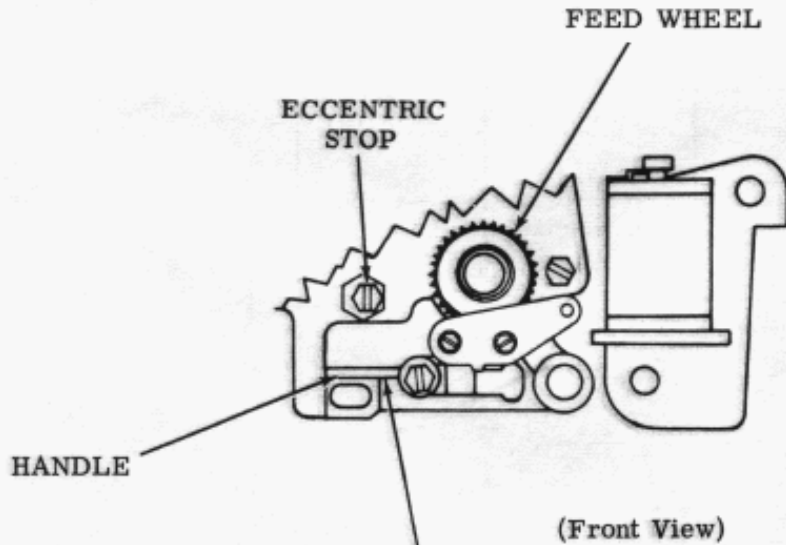

3. VARIABLE FEATURES

3.01 Universal Punch Block

Note 1: Standard punch mechanism adjustments also apply to universal punch block. Following are additional adjustments that apply only to universal punch block.

Note 2: Universal punch block adjustments should be made before TEN TO THE INCH (FINAL) (2.22) adjustment.

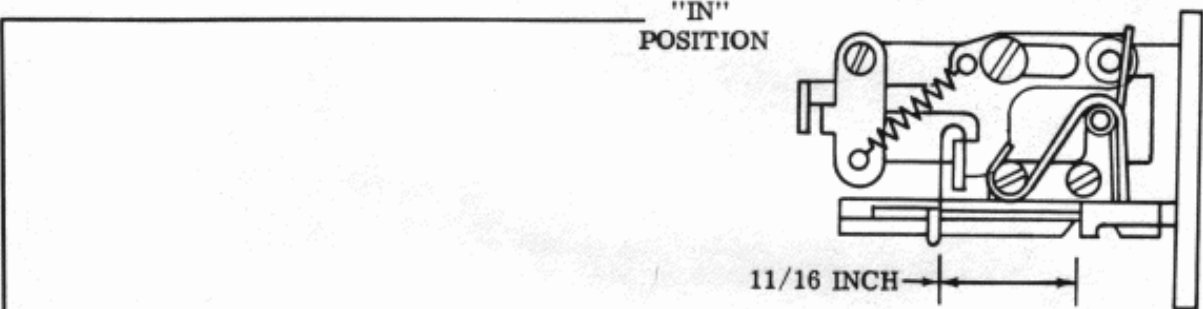

5-LEVEL TAPE
(Right Side View)

TAPE GUIDE WIDTH

Requirement

Operating lever should be positioned for width of tape used.

- (1) 11/16 inch tape. extreme "in" position
- (2) 7/8 inch tape. "mid" position
- (3) 1 inch tape. extreme "out" position

To Adjust
Position tape guide operating lever by hand.

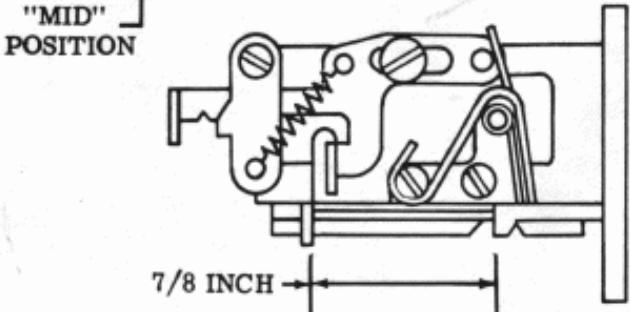

6- AND 7-LEVEL TAPE

(Right Side View)

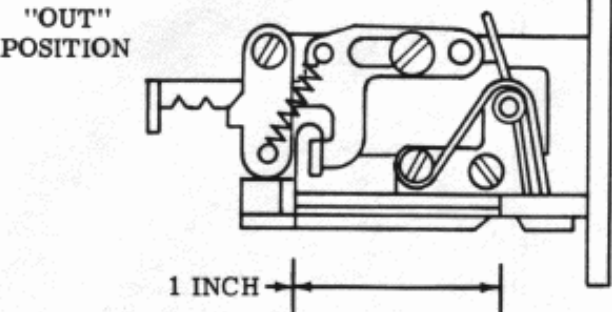

8-LEVEL TAPE

(Right Side View)

3.02 Universal Punch Block (continued)

LATCH BRACKET

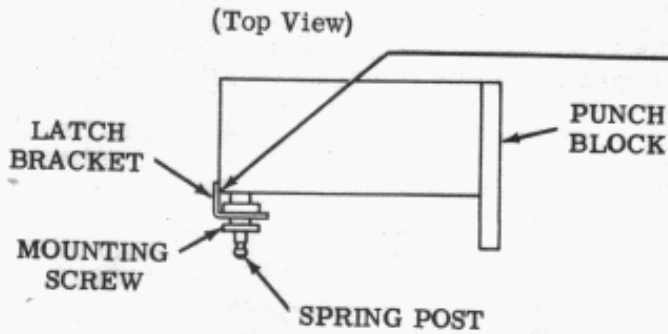

Requirement
A 0.002 inch gauge should not enter, at point of least clearance, between latch bracket and punch block.

To Adjust
With spring post and mounting screw loosened, position latch bracket against face of punch block. Tighten mounting screw and spring post.

TAPE GUIDEPLATE

(1) Requirement

With tape guide in "mid" position and torsion spring endplay taken up to maximize clearance, clearance between lever with post and torsion spring should be
Min some---Max 0.005 inch

(See illustration in TAPE GUIDE BIASING SPRING (3.03) adjustment)

(2) Requirement

With tape guide in "in" position, tape guideplate should rest against front edge of slot in die plate.

To Adjust

With mounting screws friction tight, position bracket. Tighten screws.

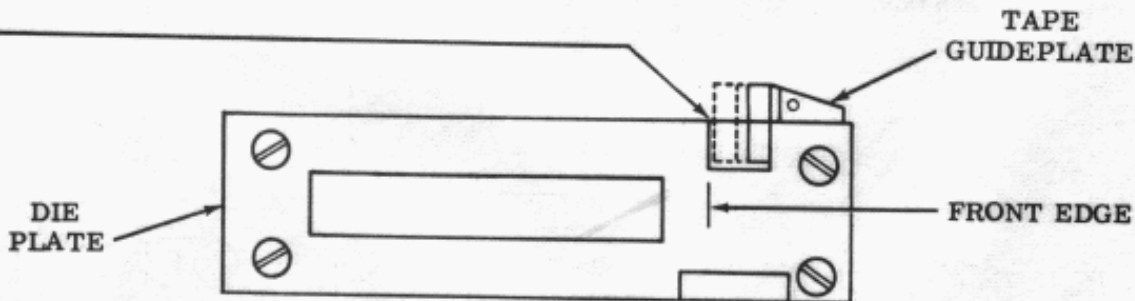

(Bottom View)

3.03 Universal Punch Block (continued)

TAPE GUIDE BIASING SPRING

Requirement

Tape guide biasing spring should be concentric with post as gauged by eye.

To Adjust

With mounting screw loosened, position spring. Tighten mounting screw while holding spring.

(Requirement (1) in
TAPE GUIDEPLATE
(3.02) adjustment)

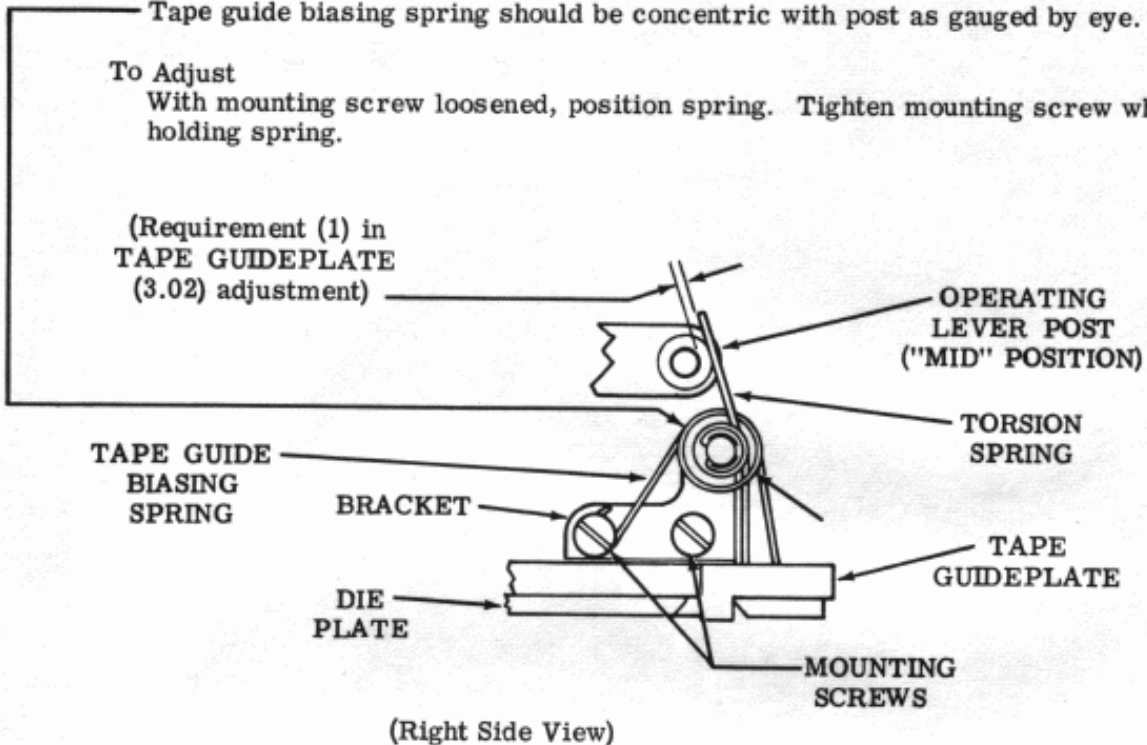

OPERATING LEVER SPRING

To Check

Unhook spring from operating lever.

Requirement

With operating lever in 1 inch tape position, it should require

Min 5 oz---Max 10 oz
to pull spring to installed length.

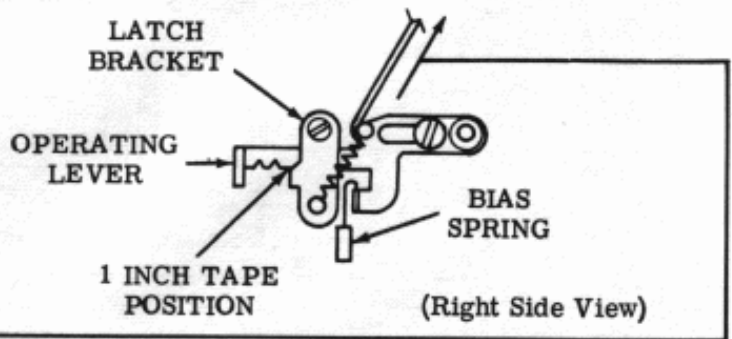

3.04 Universal Punch Block (continued)

TAPE BIAS SPRING (UNIVERSAL PUNCH BLOCK)

To Check

Perforate 3 or 4 feet of tape with all code levels marking. With one end of tape held at eye level, sight down tape. There should be no wavering in alignment of perforations with respect to edge of tape.

(1) Requirement

Spring should bias tape towards rear of punch block without crimping or curling front edge of tape.

(2) Requirement

With lever in one inch position and tape inserted in punch block, clearance between bias spring and bias spring stop should be
Min 0.005 inch---Max 0.020 inch

To Adjust

Add or remove washers on either side of bias spring stop. Tighten mounting screw.

Note: Spring must not bind against punch block casting or die plate.

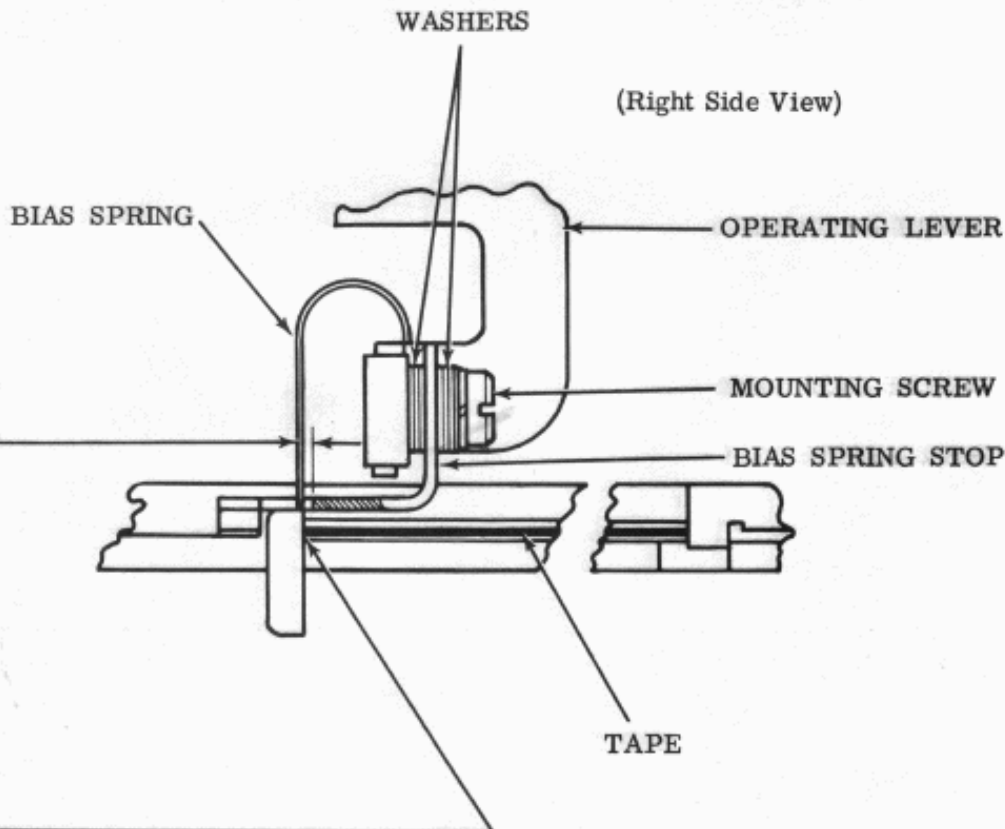

3.05 Universal Punch Block (continued)

TAPE GUIDE-ROLLER POSITION (If Equipped)

Requirement

Tape guide should be positioned for width of tape in use.

To Adjust

Press lower outside end of tape guide in at lock tension release point and position guide.

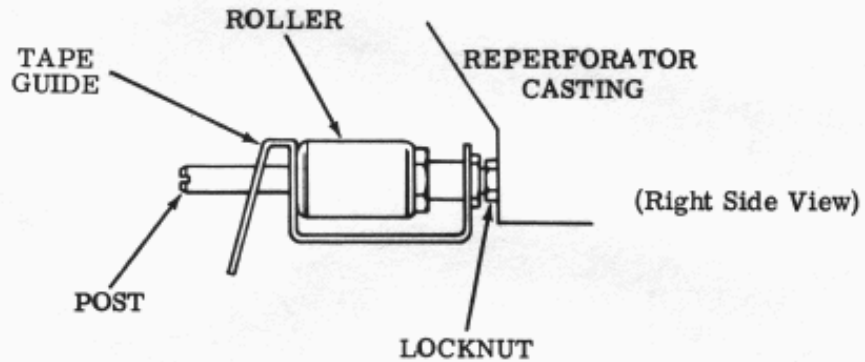

5 LEVEL POSITION

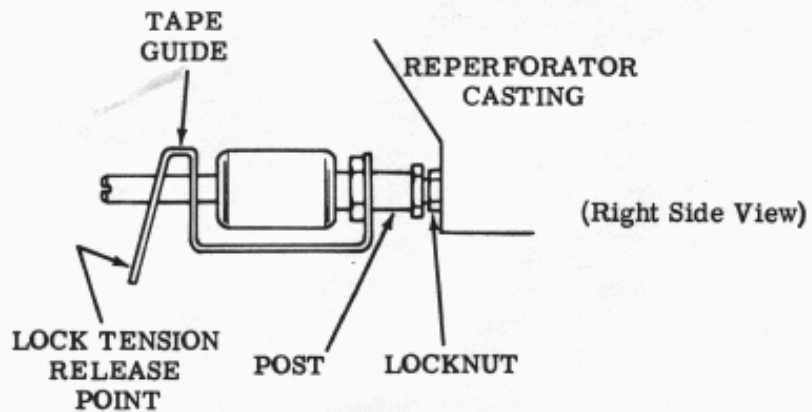

6, 7, AND 8 LEVEL POSITIONS

3.06 Universal Punch Block (continued)

ADJUSTABLE TAPE GUIDE

Requirement

Adjustable tape guide should be parallel with right tape guide as gauged by eye.

To Adjust

With locknut loosened, position adjustable tape guide to meet requirement.
Tighten locknut.

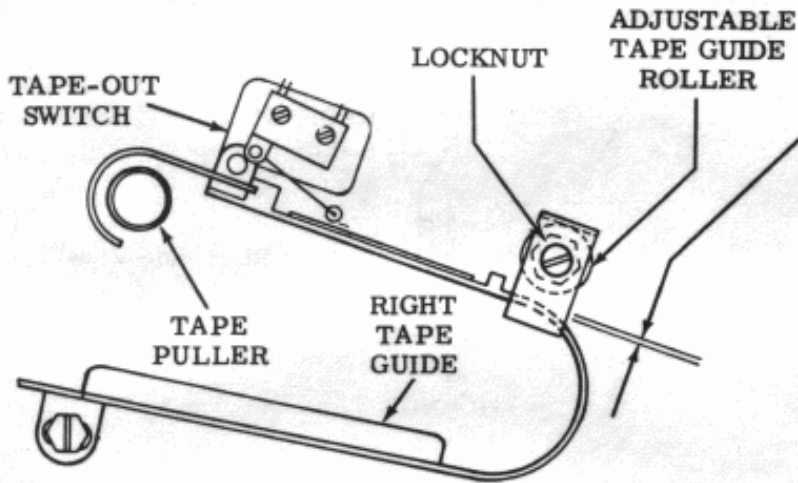

(Front View)

3.07 Photoelectric Reader (Verifier)

CAUTION: DO NOT ADJUST PHOTOVERIFIER PARTS, PUNCH PINS, OR REMOVE DIE PLATE IN PUNCH BLOCK ASSEMBLY. CARE MUST BE EXERCISED IN HANDLING GLASS WINDOW IN ORDER TO AVOID CHIPPING OR OTHERWISE DAMAGING IT.

MIRROR TUBE POSITION

Note: Because mirror tube and chad chute both extend below perforator casting, it is necessary to mount the perforator on its support frame before mirror tube and chad chute are assembled.

- (1) Requirement
Mirror tube should be horizontally and vertically aligned as gauged by eye.
- (2) Requirement
Right edge of mirror tube should be tight against, and 0.093 inch below die plate window as gauged by eye.
- (3) Requirement
Die plate window should be centered in mirror tube opening as gauged by eye.

To Adjust

While holding mirror tube assembly, loosen four mounting screws and position assembly to meet requirements. Tighten screws.

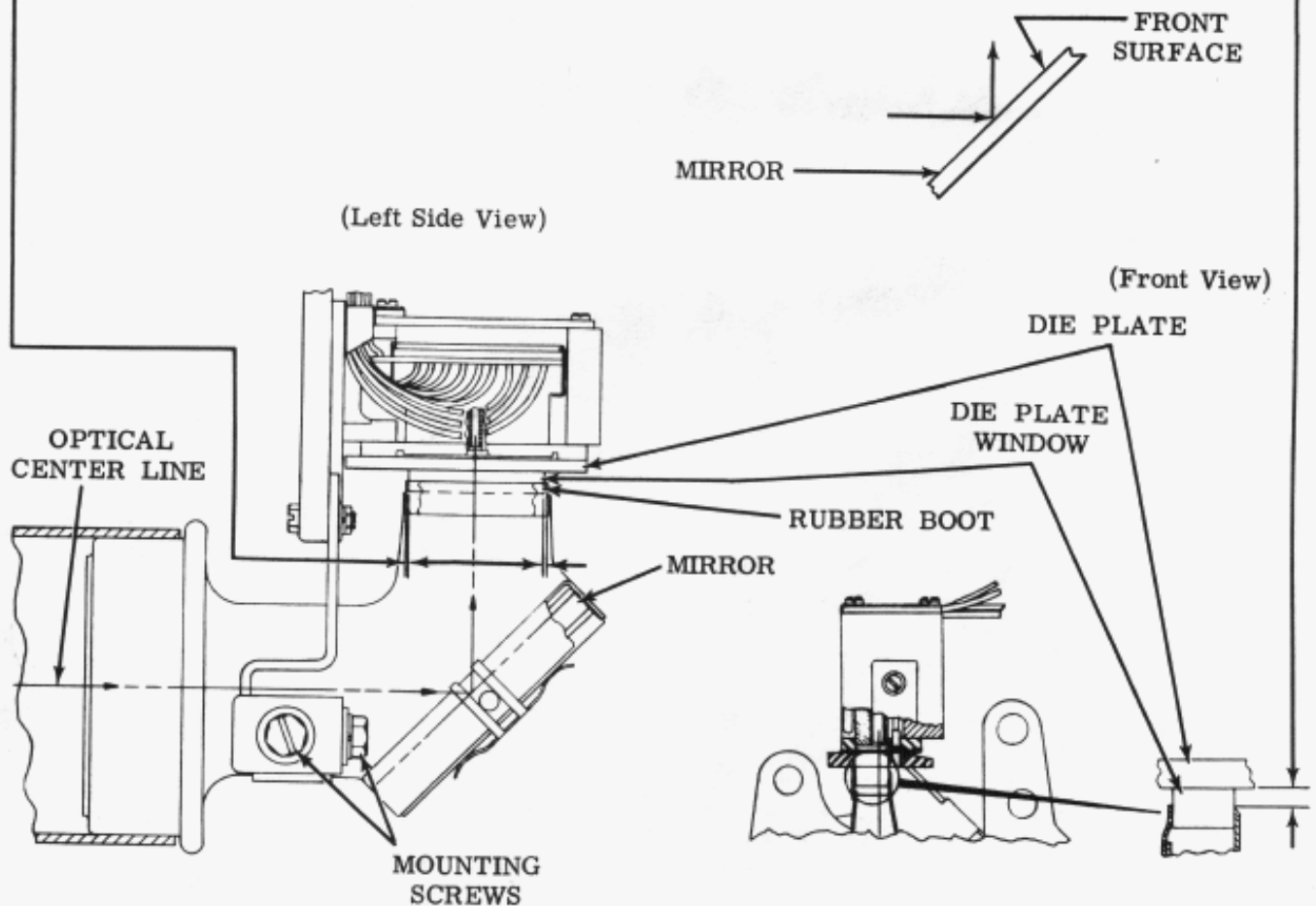

3.08 Photoelectric Reader (Verifier) (continued)

CHAD CHUTE POSITION

Requirement

Chad chute should fit snug but not tight at bottom of die plate and top of mirror tube.

To Adjust

Loosen two mounting screws and position chad chute.
Tighten screws.

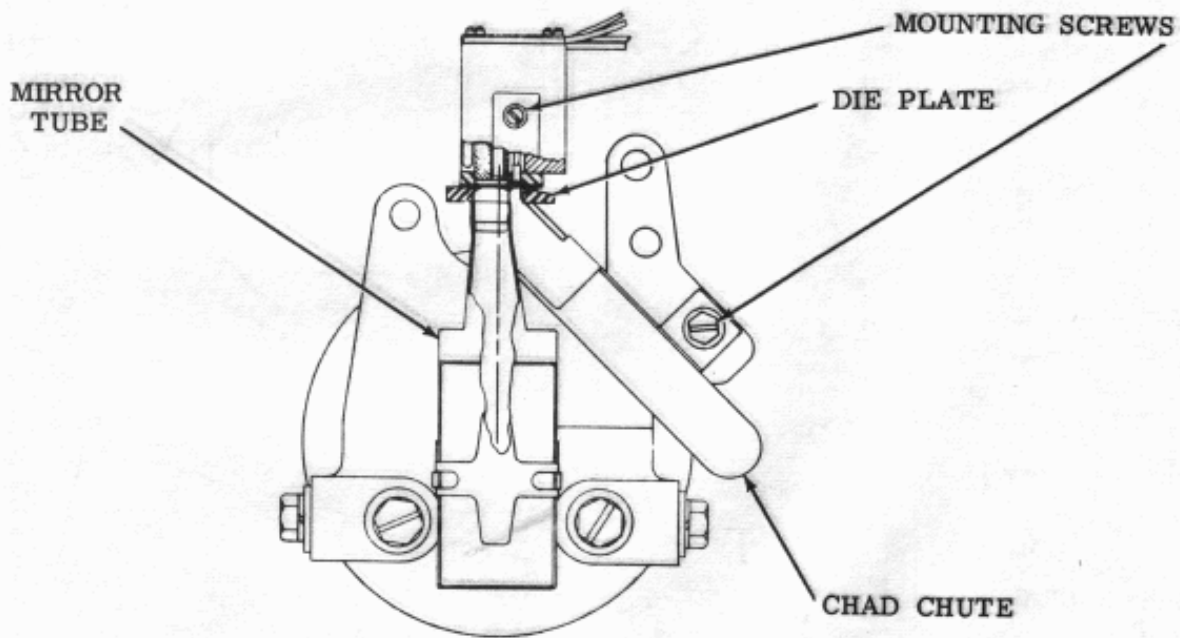

(Front View)

3.09 Photoelectric Reader (Verifier) (continued)

CAUTION 1: LAMP AND ITS HOLDER ARE EXTREMELY HOT DURING NORMAL OPERATION. EXERCISE CAUTION DURING ADJUSTMENT.

CAUTION 2: DO NOT HANDLE QUARTZ GLASS ENVELOPE OF LAMP, COLLIMATING LENS, OR PRISM. REMOVE GREASE OR FINGER PRINTS FROM LAMP BY CLEANING WITH A GREASE FREE SOLVENT SUCH AS ACETONE.

LAMP FOCUS**To Check**

With mirror and gaskets removed from mirror tube, apply 9.5 volts (ac or dc) and aim lens at a light colored wall or a sheet of paper a minimum of 10 feet away. A sharp image of lamp filament should be observed.

Requirement

Lamp filament should be at focal point of lens.

To Adjust

Position lamp relative to lens with lamp housing cover removed and lamp mounting plate screws loosened. Tighten screws and replace cover.

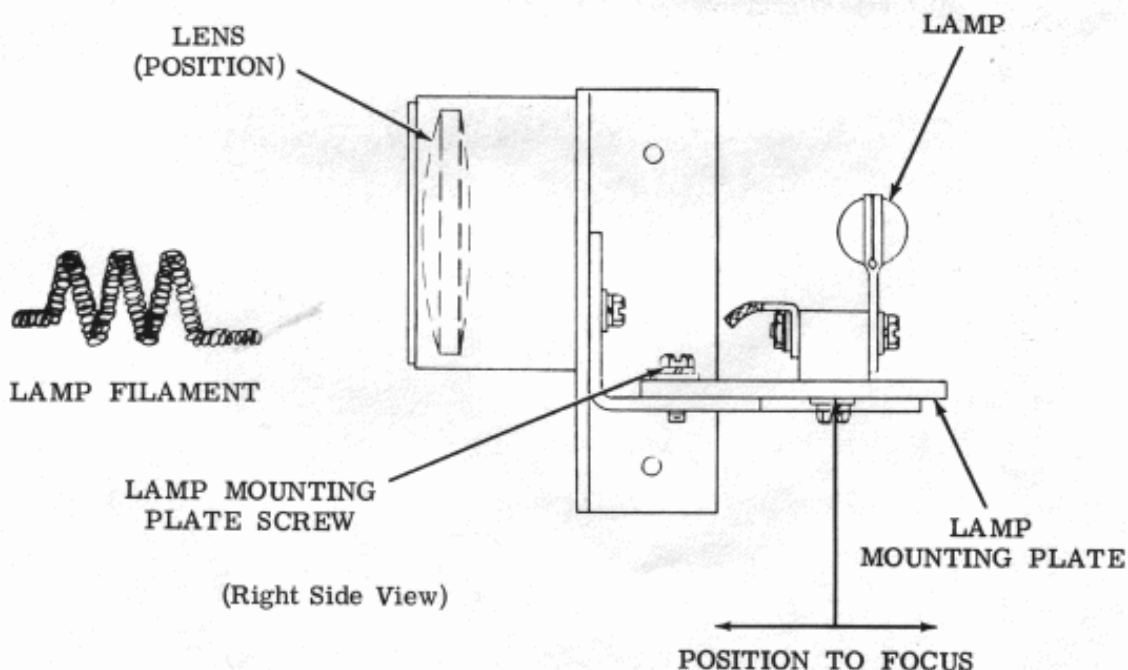

3.10 Photoelectric Reader (Verifier) (continued)

LAMP POSITION

To Check

Connect appropriate collector (refer to 7565WD) to ground through a low impedance ammeter. Apply -6 volts dc to phototransistor emitters (common) (black lead in cable).

Requirement (Preliminary)

In normal operating position, and 9.5 volts applied to lamp, lamp housing should be in line with mirror tube vertically as gauged by eye. Lamp housing should be aimed for maximum output on all levels.

Note 1: Balance all nine levels such that each level value is neither too high nor too low.

To Adjust (Preliminary)

Loosen two screws securing vertical mounting bracket to lamp assembly. Aim lamp housing vertically and horizontally to meet requirement. Tighten screws.

Requirement (Final)

Lamp housing should be aimed such that phototransistor outputs for all levels (including feed) will be 1.3 ma minimum.

To Adjust (Final)

Loosen six screws securing bracket to mounting surface and bracket with lens holder. Adjust light source in three places to meet requirement. Tighten screws.

Note 2: Adjust light source in following sequence:

- (a) vertical (up and down)
- (b) vertical rotation
- (c) horizontal rotation
- (d) tighten all adjusting screws

3.11 Photoelectric Reader (Verifier) (continued)

LAMP POSITION (continued)

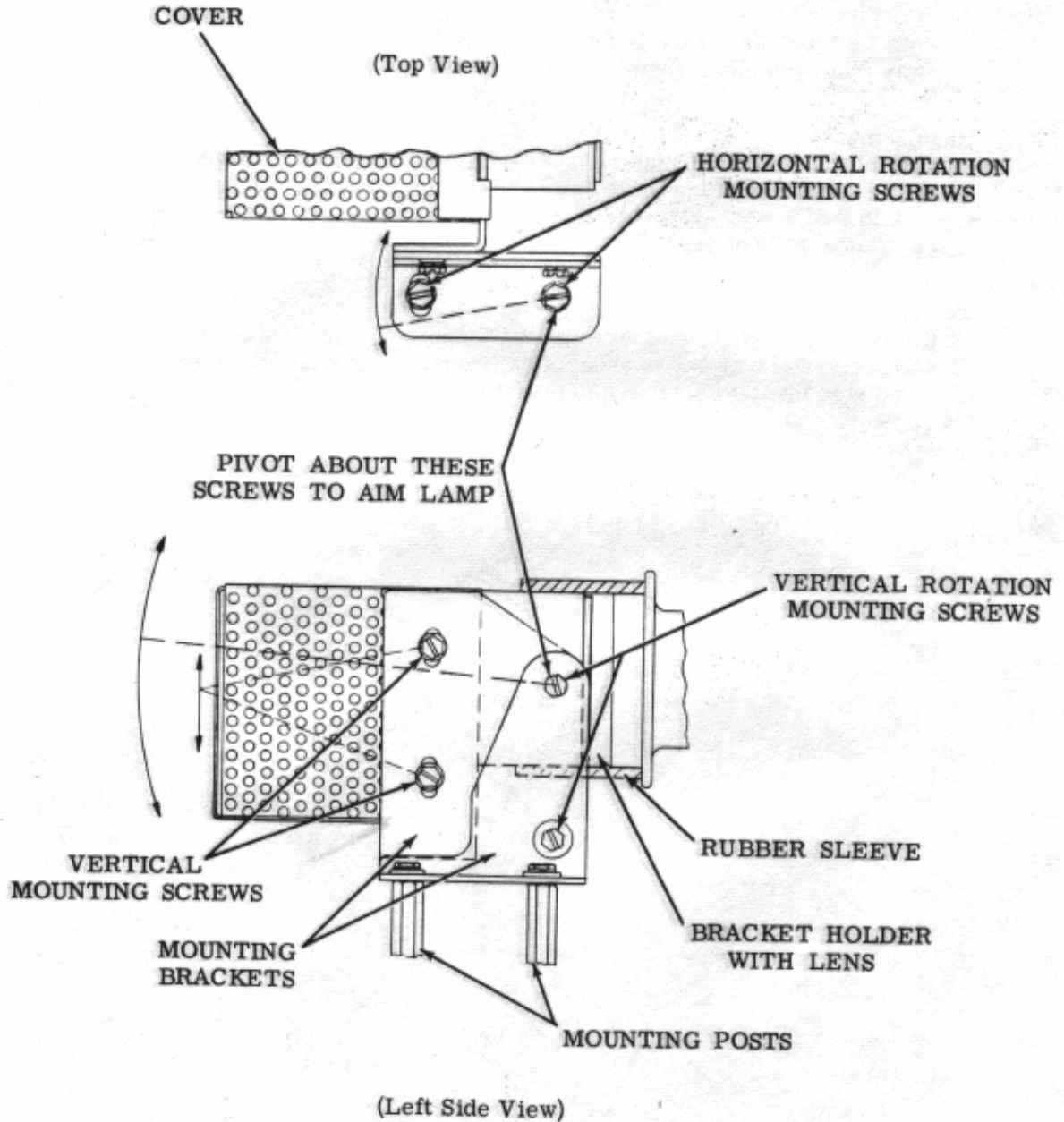

3.12 Punch Backup Mechanism

CLUTCH MAGNET ARMATURE

Note 1: Before attempting this adjustment, hold clutch magnet armature against magnet pole to make sure there is no gap between armature and magnet pole, and between armature and rear of magnet support bracket. Armature should not bind during normal travel.

Note 2: When armature is attracted to pole face, stop lever must move away from release lever to initiate drive shaft cycle.

Requirement

With clutch magnet armature against magnet pole and drive shaft rotated until release lever lug is directly under stop lever lug, there should be
— Min 0.008 inch---Max 0.015 inch
clearance between lugs.

To Adjust

Hold clutch magnet armature against magnet pole and rotate drive shaft until release lever lug is under stop lever lug. Loosen clampscrew and move stop lever to meet requirement.

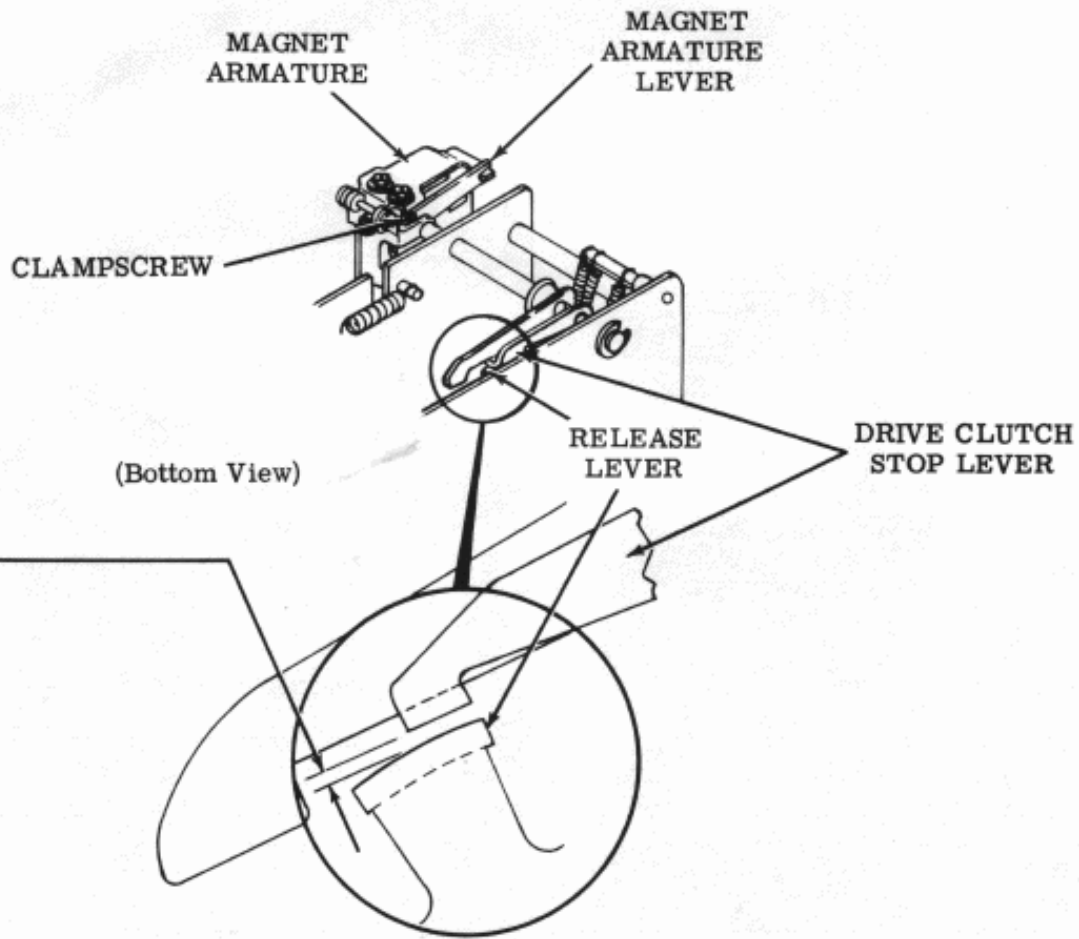

3.13 Punch Backup Mechanism (continued)

DRIVE CAM FOLLOWER LEVER

Note: Drive cam assembly positions tape guide assembly over reverse feed wheel before intermediate shaft begins to rotate.

Requirement

With magnet armature held against magnet pole, rotate drive shaft until end edge of drive clutch stop lever is about to line up with white marker (near rim) on drive cam disc. Then slowly rotate drive shaft in its normal direction to a point where intermediate clutch stop lever begins to move away from intermediate clutch release lever. At this point, edge of drive clutch stop lever should line up with same portion of marker on drive cam disc.

To Adjust

Actuate magnet by hand and rotate drive shaft until end edge of drive clutch stop lever lines up with center of marker on drive cam disc. Loosen clampscrew friction tight. Hold drive cam follower lever against roller of drive shaft cam assembly and move intermediate clutch stop lever to meet requirement. Tighten clampscrew.

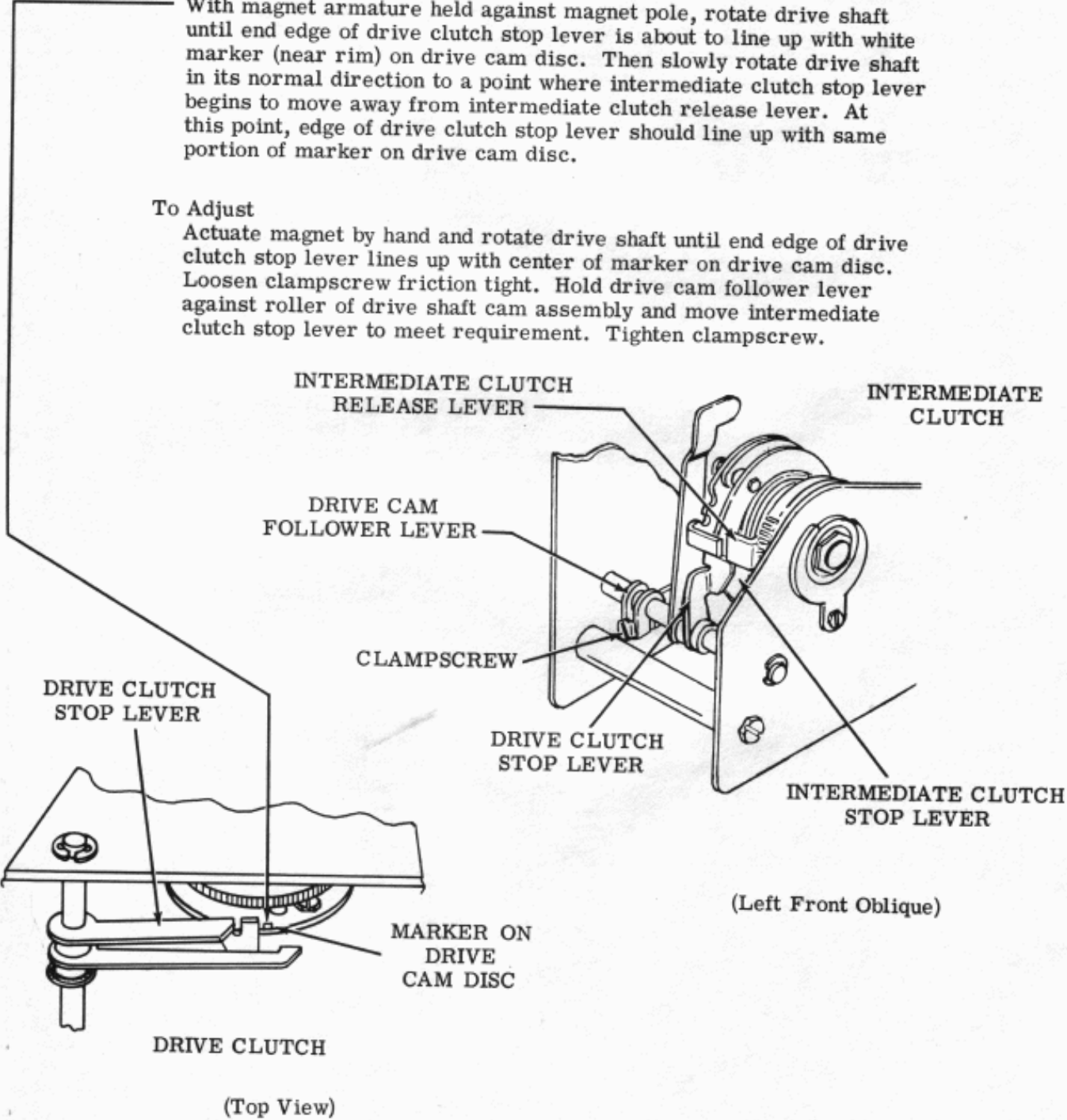

3.14 Punch Backup Mechanism (continued)

CLUTCH SPRING ANCHOR PLATE (BOTH CLUTCHES)

Note 1: This adjustment is to prevent inside of both clutch springs from dragging against surface of clutch drum prior to engagement.

Note 2: (For Intermediate Shaft Assembly Only) If clutch spring is disengaged too soon, less than 80 characters may be backed-up by reverse feed wheel.

To Check

With drive shaft rotated until all clutches are disengaged, rotate clutch stop lever out away from clutch. Lug of clutch release lever will snap forward. With light pressure, push lug of release lever forward to overcome slight friction.

Requirement

With clutches disengaged and clutch release lever positioned forward with light pressure, there should be

Min 0.100 inch---Max 0.225 inch
clearance between leading edges of clutch release lever lug and cam assembly stop-lug. Minimum clearance narrows gap between inside of clutch spring and outer surface of clutch drum. Maximum clearance increases gap.

To Adjust

To Increase Clearance: Loosen both clutch spring anchor plate adjustment clampscrews friction tight and move clutch spring anchor plate in direction of normal clutch rotation.

To Decrease Clearance: Loosen both clutch spring anchor plate adjustment clampscrews friction tight and move clutch spring anchor plate in opposite direction of normal clutch rotation. Note that to move anchor plate back, clutch release lever must be pushed in same direction simultaneously which prevents clutch spring from locking up.

3.15 Punch Backup Mechanism (continued)

CLUTCH SPRING ANCHOR PLATE (BOTH CLUTCHES) (continued)

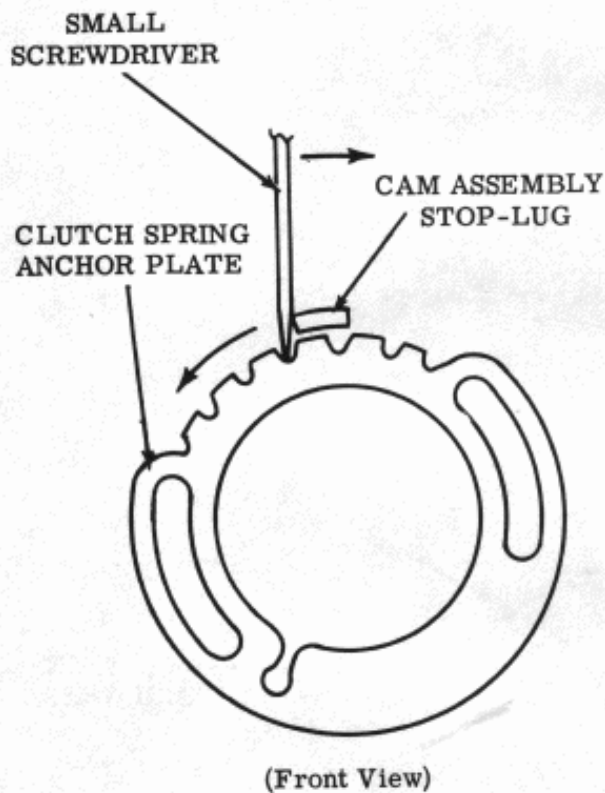
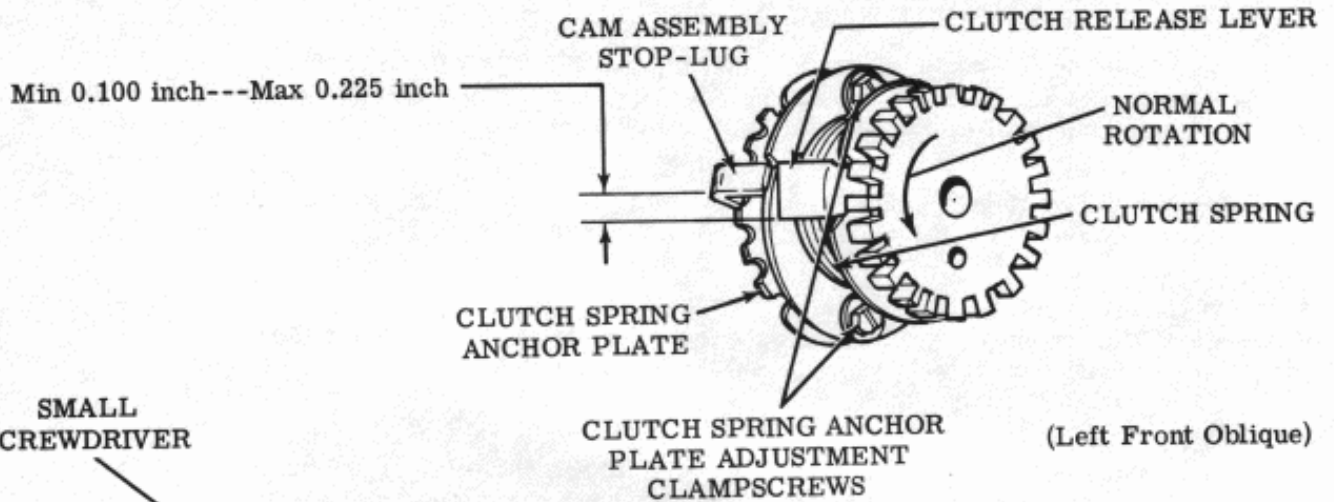

Note 3: Normal rotation for intermediate shaft assembly is shown here, but is reversed for drive shaft assembly.

Note 4: Use a small screwdriver to pry clutch spring anchor plate forward to increase distance, or backward to decrease distance.

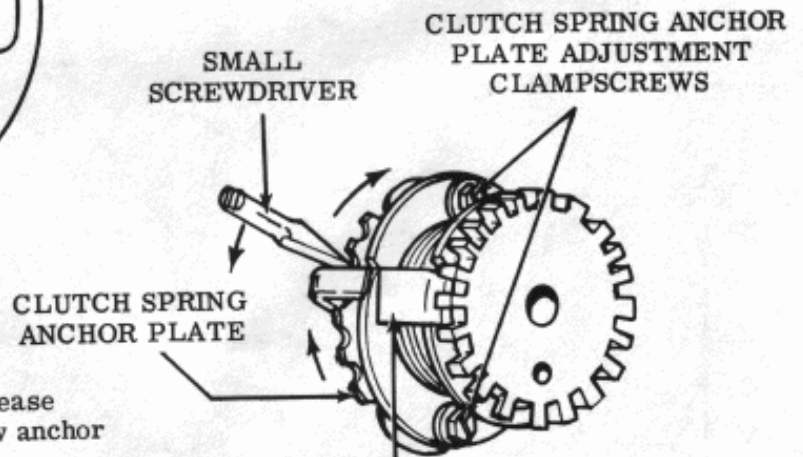

Note 5: To decrease distance, release lever must be pushed back to allow anchor plate to move.

3.16 Punch Backup Mechanism (continued)

REVERSE FEED WHEEL DETENT DISC POSITIONING

Note 1: This adjustment is to assure that the tape will be backed up 80 characters $\pm 1/2$ character. See 3.31 for adjustment to assure that the tape will be backed up exactly 80 characters.

Note 2: Mounting holes in washer, disc, feed wheel, and gear hub must remain in line for mounting screw installation.

Requirement

With magnet armature released and all clutches disengaged, detent roller should seat in feed wheel detent disc notch.

To Adjust

Loosen both disc mounting screws. Hold release lever lug of intermediate shaft drum and gear assembly against its stop lever and turn disc to meet requirement. If requirement cannot be met, remove both screws, detent lever, lever spring, and retainer holding feed wheel. Pull feed wheel out until gears unmesh and turn feed wheel in required direction to meet requirement. Push feed wheel in to engage gear teeth. Replace hardware but do not tighten screws. Reposition notch and roller then tighten screws. Refine adjustment if necessary.

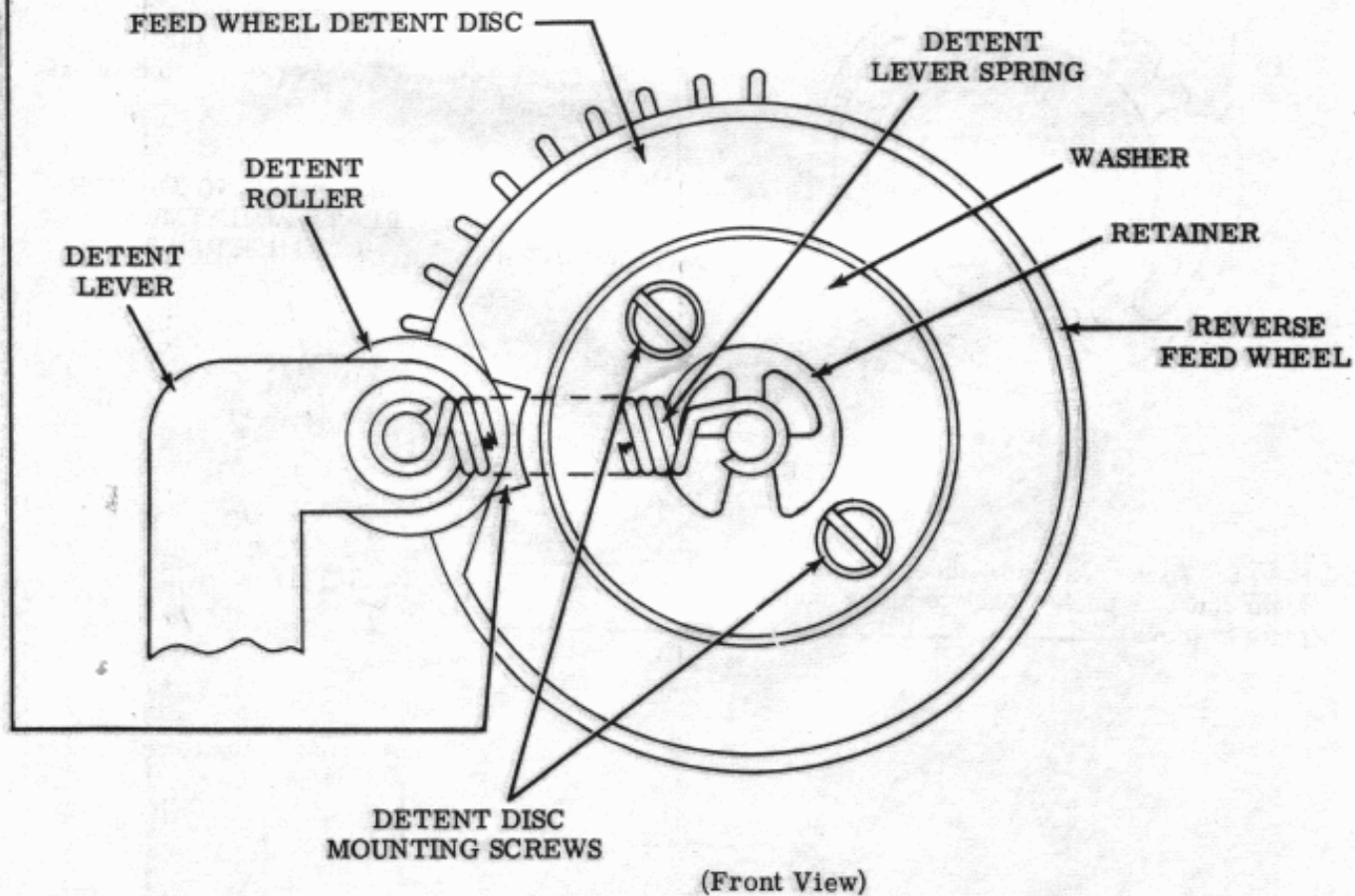

3.17 Punch Backup Mechanism (continued)

BACKUP SWITCH ACTUATING PLATE

Note: The backup switch provides the electronic monitor for backup error control.

Requirement

With magnet armature against magnet pole and shaft rotated until main bail follower arm roller is at high part of drive cam, switch lever should depress switch button.

To Adjust

Loosen locknut on eccentric pivot post. (See Illustration 3.18.) Manually actuate magnet so magnet armature is against magnet pole. Rotate drive shaft until switch lever depresses switch button. Rotate eccentric pivot post to meet requirement. Tighten locknut.

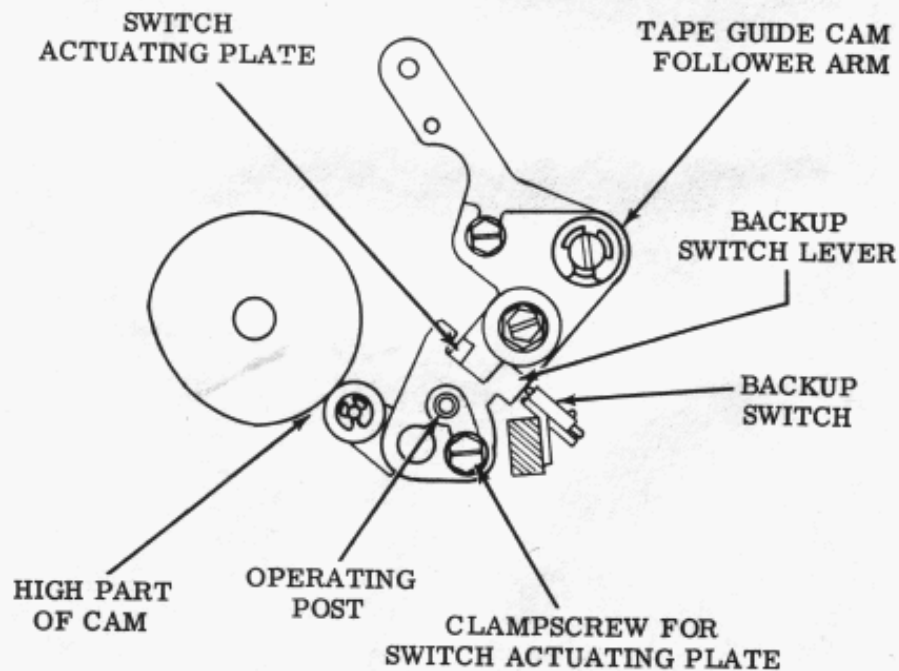

(Front View)

3.18 Punch Backup Mechanism (continued)

BACKUP SWITCH

(1) Requirement

With trip magnet actuated and drive shaft rotated until tape guide cam follower arm roller is on high part of cam, tape lid switch contact should open.

(2) Requirement

With trip magnet actuated and drive shaft rotated until follower arm roller is on low part of cam, tape lid switch contact should close.

To Adjust

Loosen clampscrew of switch actuating plate and move plate to meet requirements. Tighten screw.

BACKUP SWITCH CONTACT OPERATION

To Check

Check operation of backup switch contact with oscilloscope.

(1) Requirement

Contact should open and close as required.

(2) Requirement

There should be no momentary contact closures or breaks during normally open or closed times.

To Adjust

Loosen clampscrew of switch actuating plate and move plate to meet requirements.

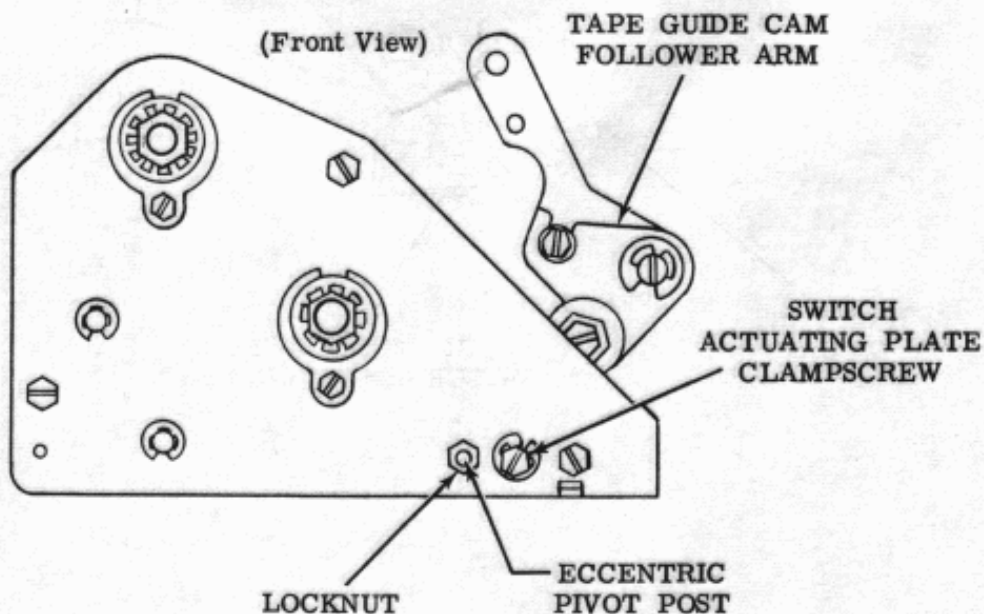

3.19 Punch Backup Mechanism (continued)

TAPE GUIDE (PRELIMINARY) EARLY DESIGN**Requirement**

Loosen three mounting screws fastening upper guide to lower guide. (See illustration in 3.20.) Move upper guide to obtain maximum gap between guides. Tighten screws.

Note: To remove tape guide assembly, proceed as follows: move turned end of tape guide torsion spring from spring post to tape guide lever projection, pivot tape guide slightly clockwise until both feed wheels are clear, and then remove tape guide assembly.

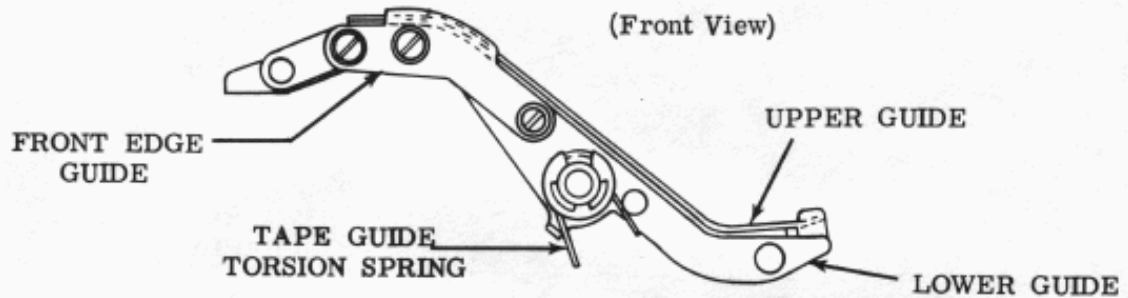
TAPE EDGE GUIDE (ONE INCH) EARLY DESIGN**Requirement**

Top edges of three adjustable tape edge guides should be level with bottom of tape and should not press against tape.

To Adjust

Loosen guide adjusting screws and move guides down to meet requirement. Gauge by eye.

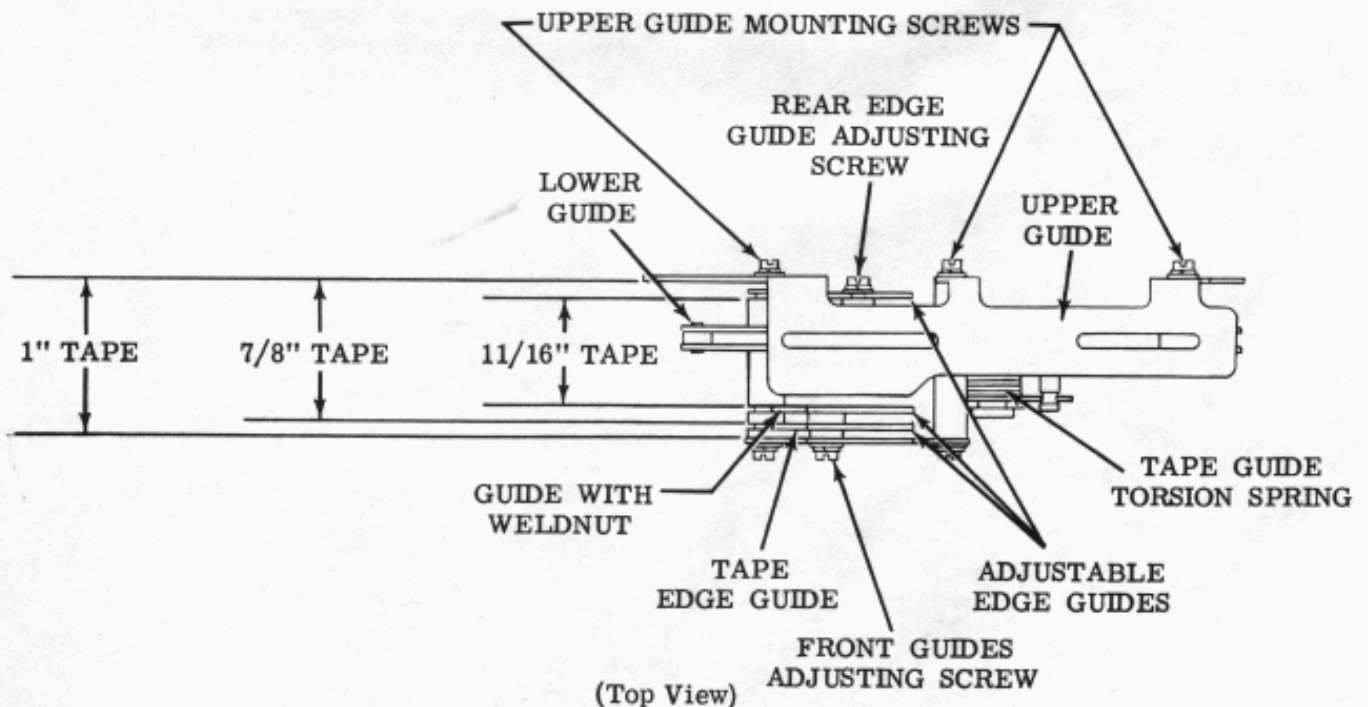

3.20 Punch Backup Mechanism (continued)

TAPE EDGE GUIDE (SEVEN-EIGHTHS INCH TAPE) EARLY DESIGN

Requirement

Top edge of front tape guide should be aligned with top edge of permanent tape guide while tops of remaining two guides are level with bottom of tape threaded through guide. There should not be pressure against tape. (See illustration in 3.19.)

To Adjust

Loosen guide adjusting screws and move guides up or down to meet requirement. Gauge by eye.

TAPE EDGE GUIDE (ELEVEN-SIXTEENTHS INCH TAPE) EARLY DESIGN

Requirement

Top edges of three guides should be aligned with top edge of permanent guide. (See illustration in 3.19.)

To Adjust

Loosen guide adjusting screws and move guides up to meet requirement. Gauge by eye.

Note: To install tape guide assembly, proceed as follows: place tape guide assembly on its respective pivot post and move assembly to rear while clearing feed wheels, align feed wheels within slot of guide and rotate assembly counterclockwise, and then lift formed end of lid assembly torsion spring and place over post in slot on cam follower lever so end of spring rests in slot.

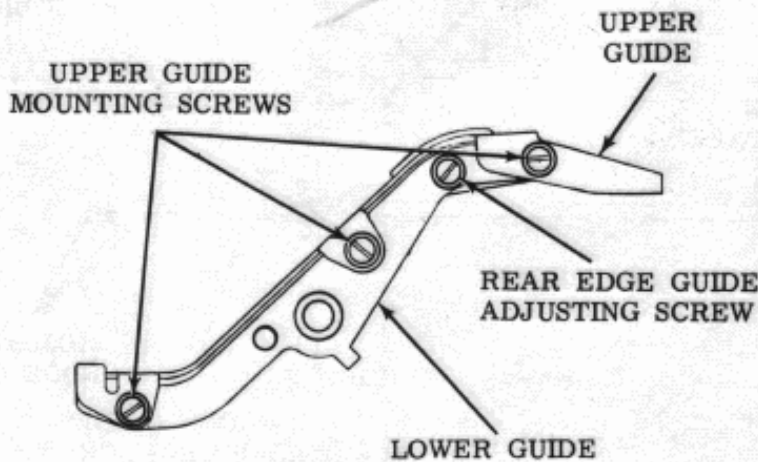

(Rear View)

3.21 Punch Backup Mechanism (continued)

TAPE GUIDE (PRELIMINARY) LATE DESIGN**Requirement**

Loosen three mounting screws fastening upper guide to lower guide. (See illustration in 3.22.) Move upper guide to obtain maximum gap between guides. Tighten screws.

Note: To remove tape guide assembly, proceed as follows: move turned end of tape guide torsion spring from spring post to tape guide lever projection, pivot tape guide slightly clockwise until both feed wheels are clear, and then remove tape guide assembly.

(Front View)

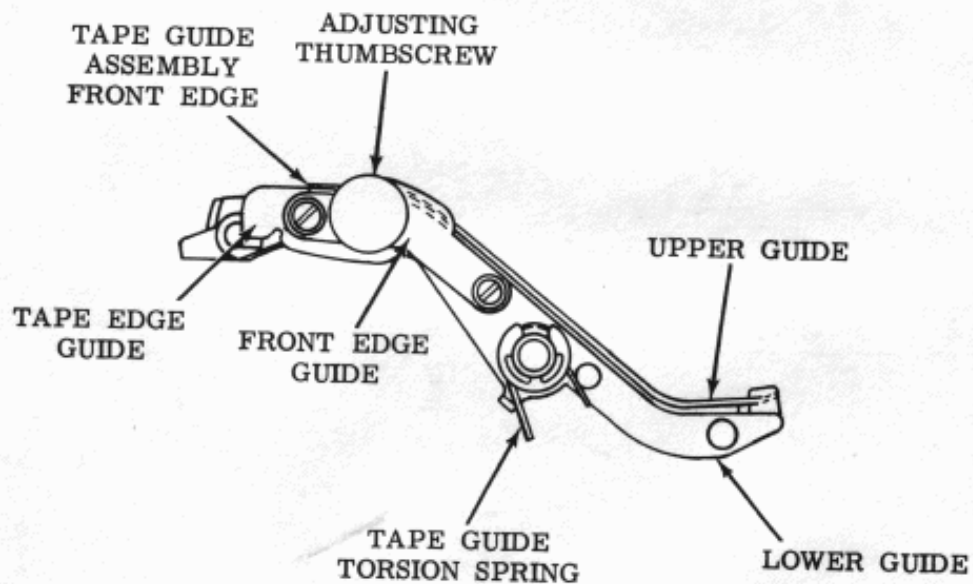

3.22 Punch Backup Mechanism (continued)

TAPE EDGE GUIDE (ONE INCH) LATE DESIGN**Requirement**

Top edges of both tape edge guides should be level with bottom of tape and should not press against tape.

To Adjust

Loosen thumbscrew and move it down in its adjusting slot (extreme bottom of its travel). Edge tape guide should also move down. Push up on tab on edge tape guide (stamped 7/8) to be sure that guide remains down. Tighten thumbscrew.

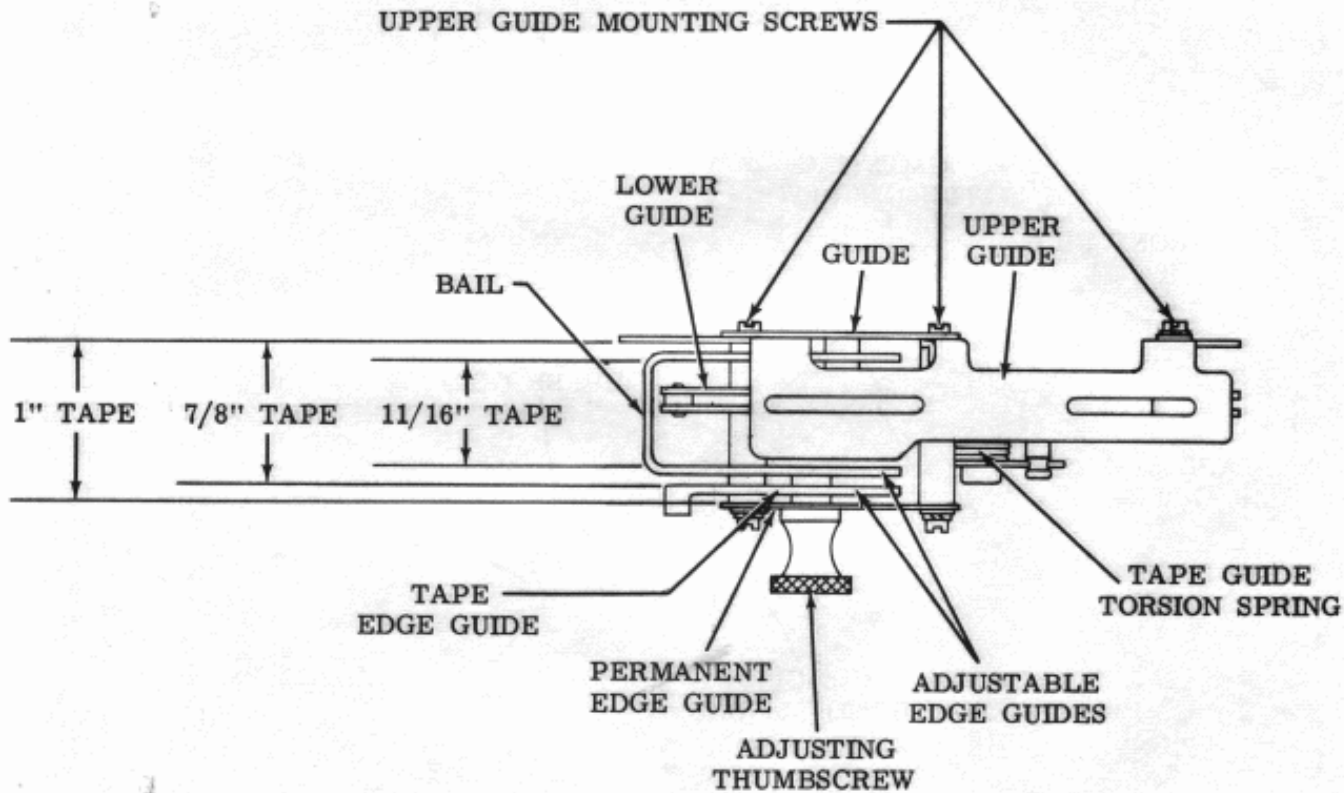

(Top View)

3.23 Punch Backup Mechanism (continued)

TAPE EDGE GUIDE (SEVEN-EIGHTHS INCH TAPE) LATE DESIGN**Requirement**

Top edge of bail should be level with bottom of tape and should not press against tape. Tape edge guide (stamped $\downarrow 7/8$) should be against edge of tape. (See Illustration in 3.22.)

To Adjust

Loosen thumbscrew and move it down in its adjusting slot (extreme bottom of its travel). Press down on tab on edge tape guide (stamped $7/8$) to place it in seven-eighths inch wide position. Tighten thumbscrew.

TAPE EDGE GUIDE (ELEVEN-SIXTEENTHS INCH TAPE) LATE DESIGN**Requirement**

Top edges of both guides should be aligned with top edge of permanent guide. (See Illustration in 3.22.)

To Adjust

Loosen thumbscrew and move it up in its adjusting slot (extreme top of its travel). Push up on tab on edge tape guide (stamped $7/8$). Tighten thumbscrews.

Note: To install tape guide assembly, proceed as follows:
Adjust edge tape guide to $11/16$ inch tape width requirement. Place tape guide assembly on its respective pivot post and move assembly to rear while clearing feed wheels. Align feed wheels within slot of guide and rotate assembly counter-clockwise, then lift formed end of lid assembly torsion spring and place over post in slot on cam follower lever so end of spring rests in slot.

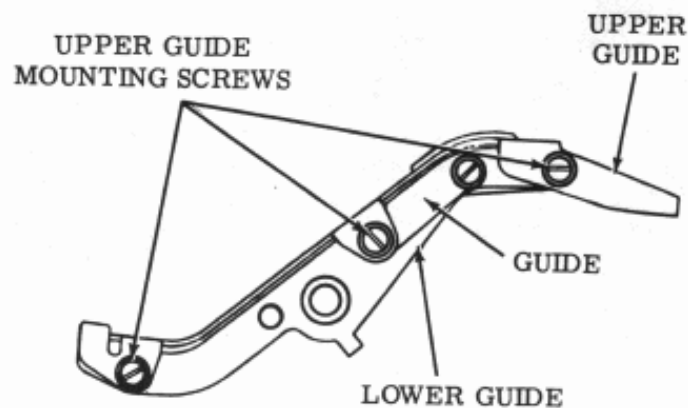

(Rear View)

3.24 Punch Backup Mechanism (continued)

FORWARD FEED WHEEL

Requirement

With shaft rotated until all clutches are disengaged, tape guide torsion spring engaged, upper tape guide adjusted all the way up (or removed), and tape lid cam follower roller on low part of drive shaft cam:

- (1) Right hand side of tape guide assembly should be aligned with forward feed wheel so that outer rim of forward feed wheel (less pins) conforms with radius of lower tape guide and clearance between forward feed wheel (less pins) and top edge of lower guide should be 0.004 inch to 0.006 inch maximum.
- (2) Left hand side of tape guide assembly should be aligned with reverse feed wheel so that top of feed pins are flush or just below top edge of lower tape guide when forward feed wheel clearance is zero as gauged by eye.
- (3) At this point, TAPE GUIDE (FINAL) (3.26) must be made.

(1) To Adjust

Loosen left and right hand eccentric stud mounting screws and turn eccentric highs up and away from tape guide assembly. Tighten eccentric stud screws. Loosen clampscrew of adjustable plate on tape guide cam follower arm and clampscrew of cam follower eccentric bushing friction tight. Rotate eccentric post and/or eccentric bushing until forward feed wheel meets requirement.

CAUTION: ECCENTRIC POST AND ECCENTRIC BUSHING CAN MEET THIS REQUIREMENT IN TWO POSITIONS, 180° OUT OF PHASE. PROPER POSITION OF ECCENTRIC POST AND ECCENTRIC BUSHING IS MET WHEN ECCENTRIC HIGHS ARE UP.

(2) To Adjust

When forward feed wheel adjustment is met, rotate eccentric bushing and/or eccentric post until top of feed pins of reverse feed wheel are flush or barely below top of lower guide of tape guide assembly. Recheck forward feed wheel clearance and refine if necessary by rotating eccentric post and/or eccentric bushing. Tighten eccentric post locknut and eccentric bushing clampscrew and recheck requirements.

3.25 Punch Backup Mechanism (continued)

FORWARD FEED WHEEL (continued)

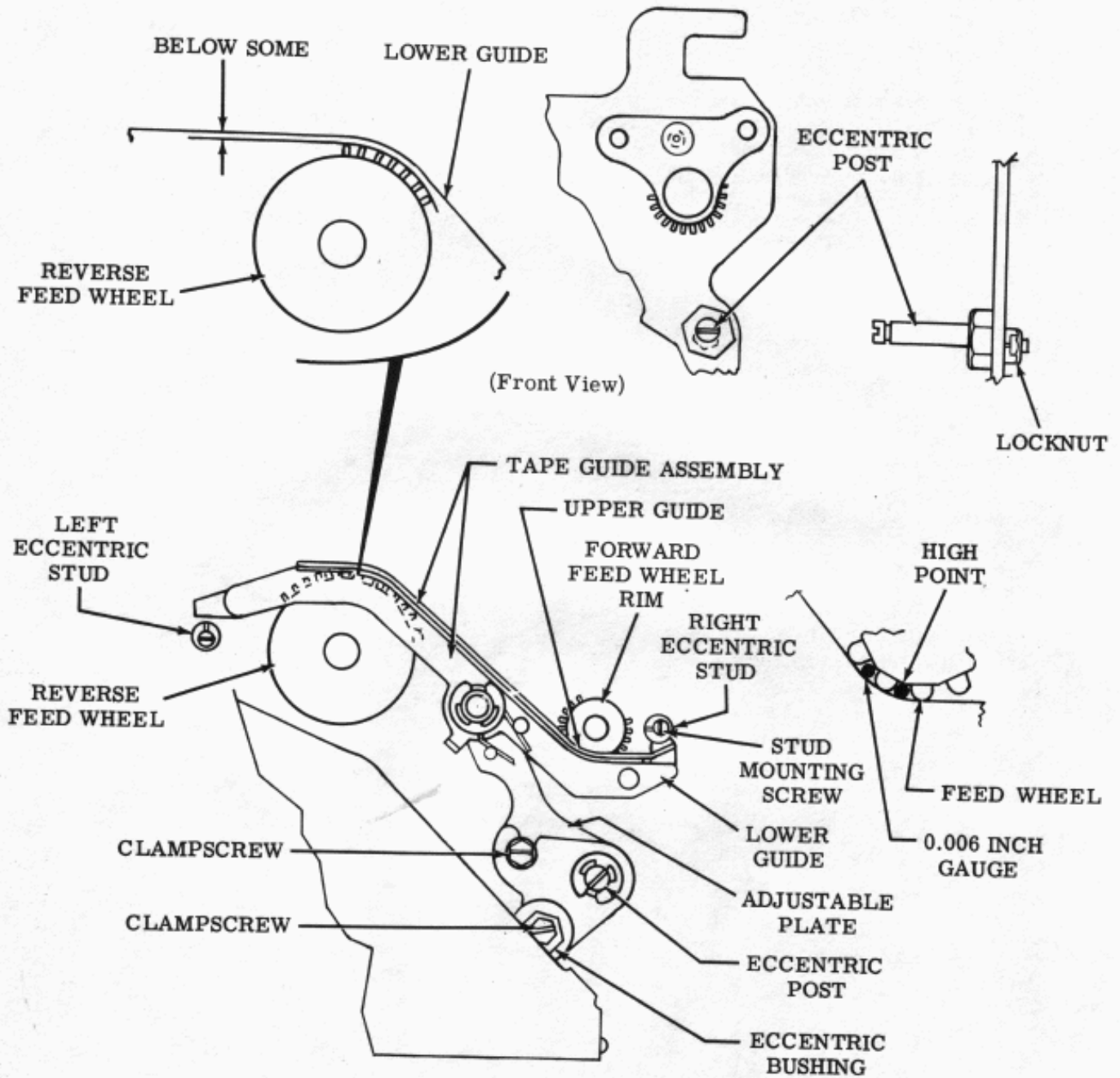

3.26 Punch Backup Mechanism (continued)

TAPE GUIDE (FINAL)

Requirement

Clearance between upper guide and lower guide should be:
Min 0.008 inch---Max 0.012 inch

To Adjust

Remove tape guide assembly. (See note in 3.19 or 3.21.)
Loosen three mounting screws fastening upper guide to lower guide.
Insert a double thickness of one inch unperforated paper tape between
tape guides. Gently press upper guide against paper tape. Paper
tape should move freely along entire path of tape guide. Tighten three
mounting screws. Install tape guide assembly. (See note in 3.20 or
3.23.)

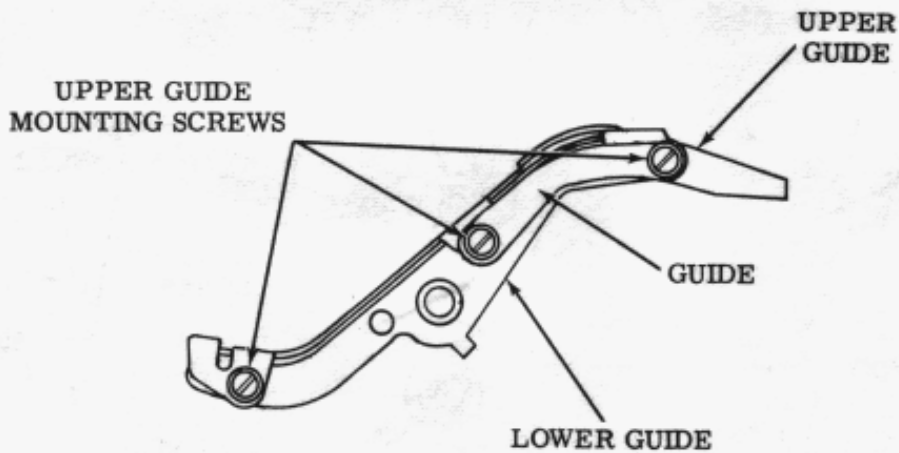

(Rear View)

3.27 Punch Backup Mechanism (continued)

REVERSE FEED WHEEL

(1) Requirement

With magnet actuated and drive shaft rotated until tape cam follower roller is on high part of cam, left portion of tape guide assembly should be aligned with reverse feed wheel so that rim of feed wheel (less pins) is centered between upper and lower guides of tape guide assembly.

(2) Requirement

With magnet actuated and drive shaft rotated until tape cam follower roller is on high part of cam, right portion of tape lid should be aligned with forward feed wheel so that feed pin tips do not appear between upper and lower guides of tape guide assembly.

To Adjust

With left eccentric stud mounting screw loosened, rotate eccentric stud to meet requirements. If, after this adjustment, forward feed wheel pins are visible between upper and lower guides, it is necessary to refine forward feed wheel adjustment (3.24).

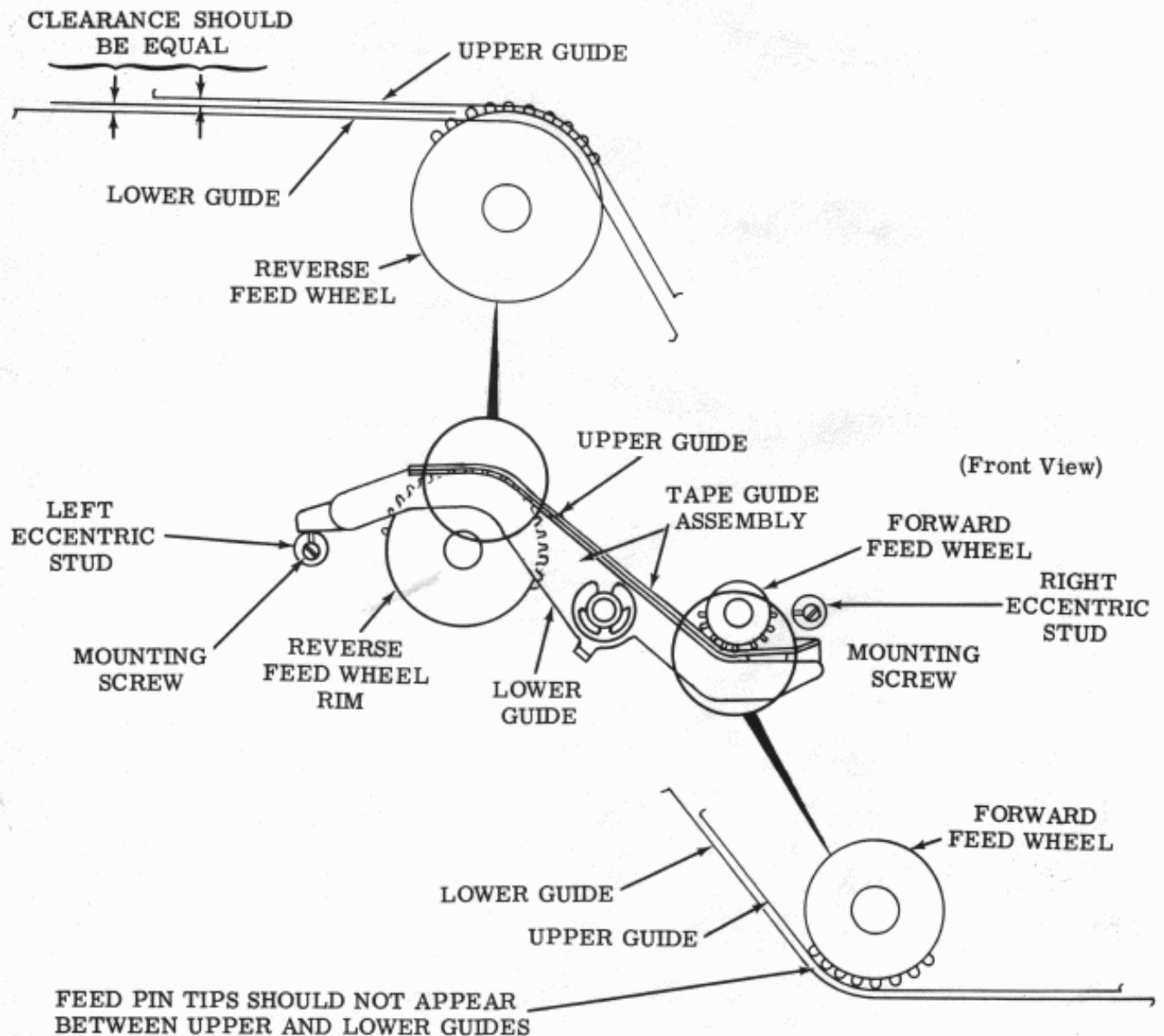

3.28 Punch Backup Mechanism (continued)

Note: The following adjustment must be made with backup mechanism and grease retainer removed from unit.

CAUTION: IF TORQUE FROM A FULLY WOUND DRIVE SPRING IS SUDDENLY RELEASED, PERMANENT DAMAGE TO SPRING WILL RESULT. SPRING TENSION CAN BE RELEASED IN STEPS AT ANTIREVERSAL DISC PAWL (2.10).

RATCHET AND PAWL ESCAPEMENT

(1) Requirement

With no torque applied to ratchet and pawl, and with ratchet and pawl operated by hand, ratchet should make equal steps on up stroke and on down stroke of pawl as gauged by eye.

(2) Requirement

It should not be possible for ratchet to move more than one step with pawl in any position.

(3) Requirement

With pawl raised, right pawl tooth should be opposite eighth (8) indent in upper half of ratchet.

To Adjust

With nut on eccentric pawl pivot post loosened, use a wrench or an Allen wrench to rotate eccentric, keeping eccentric high toward left. Tighten nut.

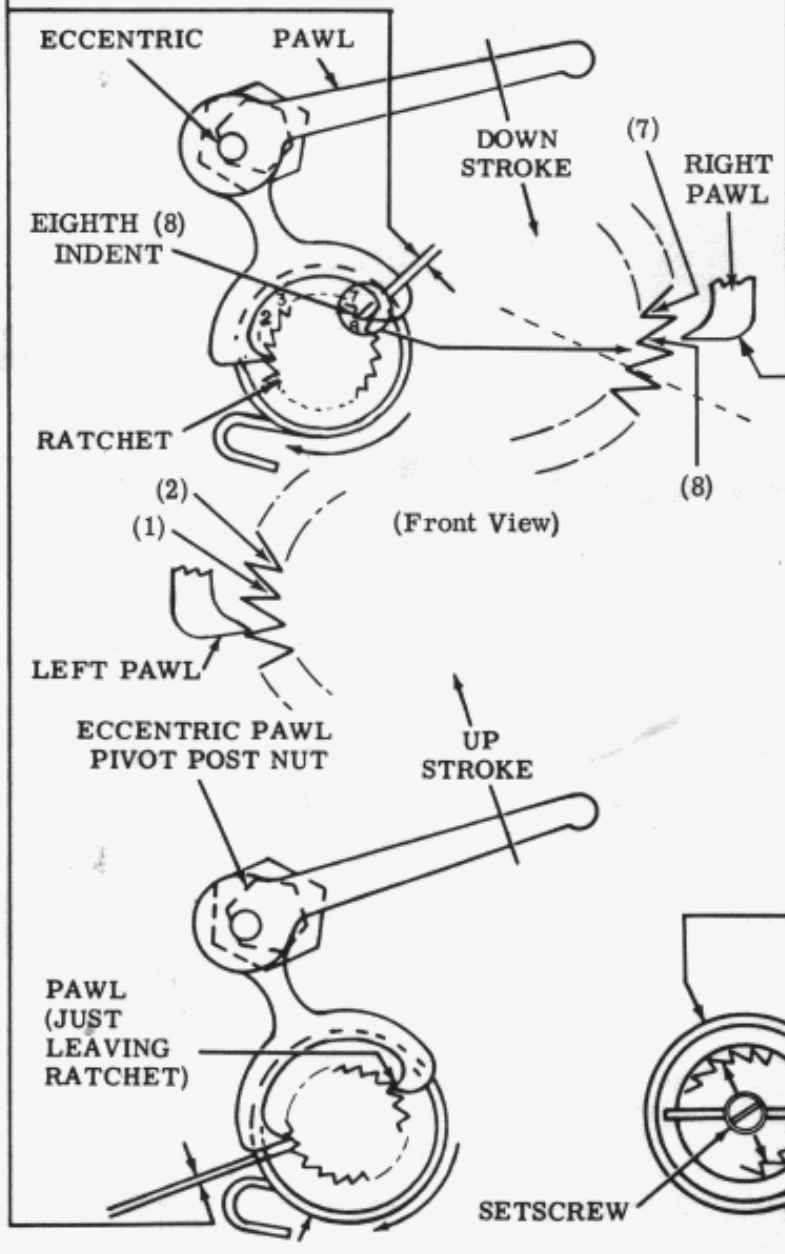

DRIVE SPRING

Requirement

Drive spring should be concentric with ratchet wheel.

To Adjust

With setscrew loosened, position spring. Hold feed wheel and tighten setscrew to 2 lb-in. with torque wrench.

3.29 Punch Backup Mechanism (continued)

FEED MECHANISM — VERTICAL POSITION

Note 1: Make the following adjustment with backup mechanism installed.

Note 2: Ratchet may fully unwind (slip) if feed magnet is de-energized and there is no tape in unit.

(1) To Check

With feed magnet de-energized and drive spring wound approximately two turns, apply light downward pressure on pawl; ratchet should step one tooth. Stepping may be determined by audible click of ratchet.

Note 3: If ratchet unwinds (accelerated stepping) during To Check at two turns of drive spring, reduce amount of turns to eliminate accelerated stepping and enable To Check stepping observation.

Requirement

With feed magnet in neutral (de-energized) position, left side pawl should just enter notched tooth.

(2) To Check

Check Requirement by observing top teeth of ratchet moving counterclockwise.

Requirement

With feed magnet energized, turn ratchet counterclockwise so that some clearance is noticeable between tooth on ratchet and left side pawl.

To Adjust

Loosen three screws securing backup mechanism to casting and two screws holding clamp to vertical positioning eccentric bushing. Turn eccentric bushing until backup mechanism is positioned vertically. Tighten screws on clamp plate first, then tighten mounting screws. Recheck FEED WHEEL LINE-UP (2.21) and refine if necessary.

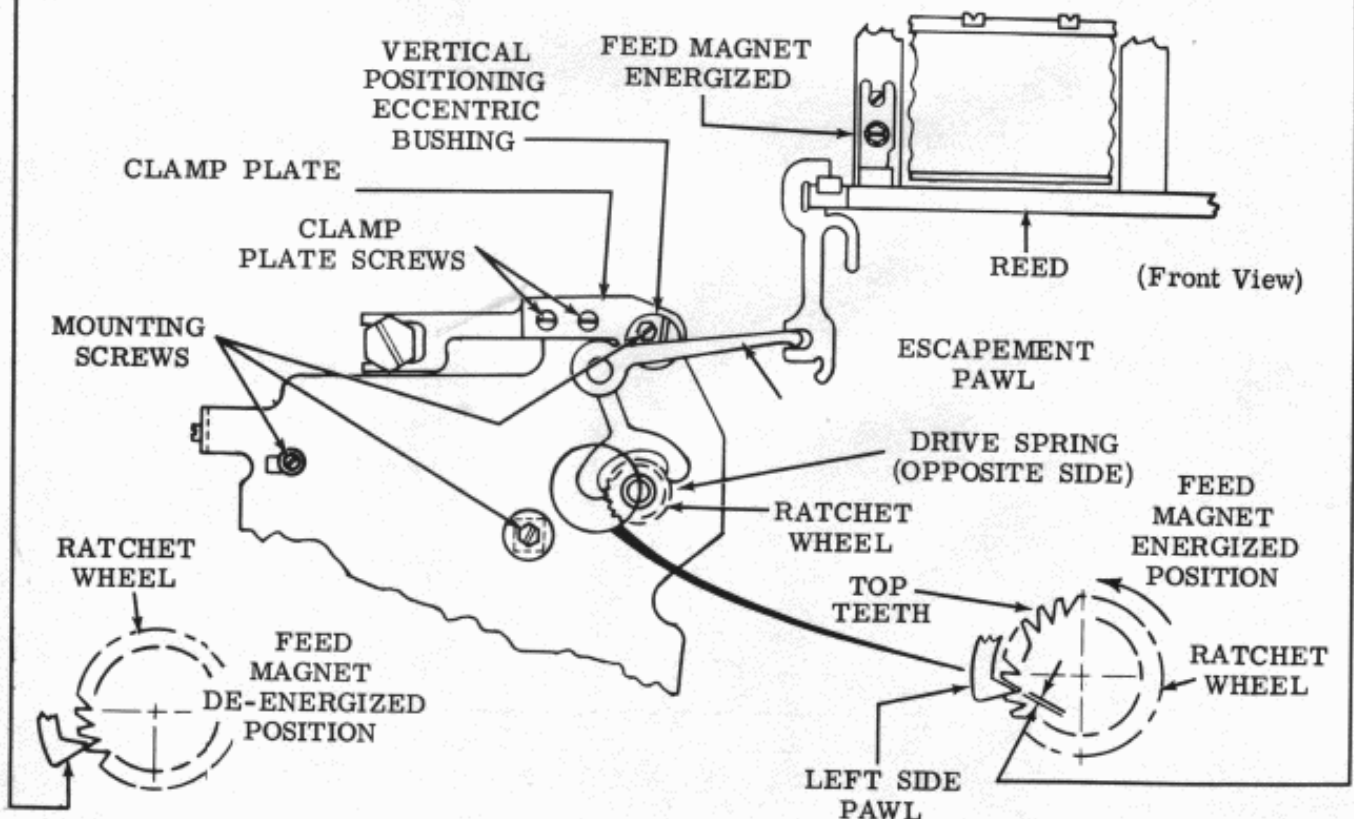

3.30 Punch Backup Mechanism (continued)

TEN TO THE INCH

Requirement

Punch should produce tape that conforms to tape gauge TP302990.

Note: First five holes in tape gauge TP302990 are same size as code holes in tape (0.072 inch diameter). Sixth hole in gauge is larger (0.102 inch diameter). This arrangement allows ± 0.015 inch variation in ten to the inch spacing over five inches.

To Check

Perforate a length of tape (at least 5 inches long) with all levels marking. Place tape over smooth side of tape gauge so that first number two code hole in tape is concentric with first hole (0.072 inch diameter) in tape gauge. Next four holes (0.072 inch diameter) in tape gauge should be visible through number two code holes in tape. Last number two code hole in tape should be entirely within sixth hole (0.102 inch diameter) in tape gauge. Favor short ten to the inch spacing at 1200 words per minute and long at 2400 words per minute (within gauge).

To Adjust

Loosen three mounting screws that fasten backup mechanism to main casting. Rotate adjusting screw clockwise to move backup mechanism toward right or counterclockwise to move it toward left until requirement is met. If ten to the inch spacing is short, backup mechanism should be moved toward left. If spacing is too long, it should be moved toward right. Tighten mounting screws and recheck FEED MECHANISM - VERTICAL POSITION (3.29) and refine if necessary. Recheck ten to the inch spacing and refine if necessary.

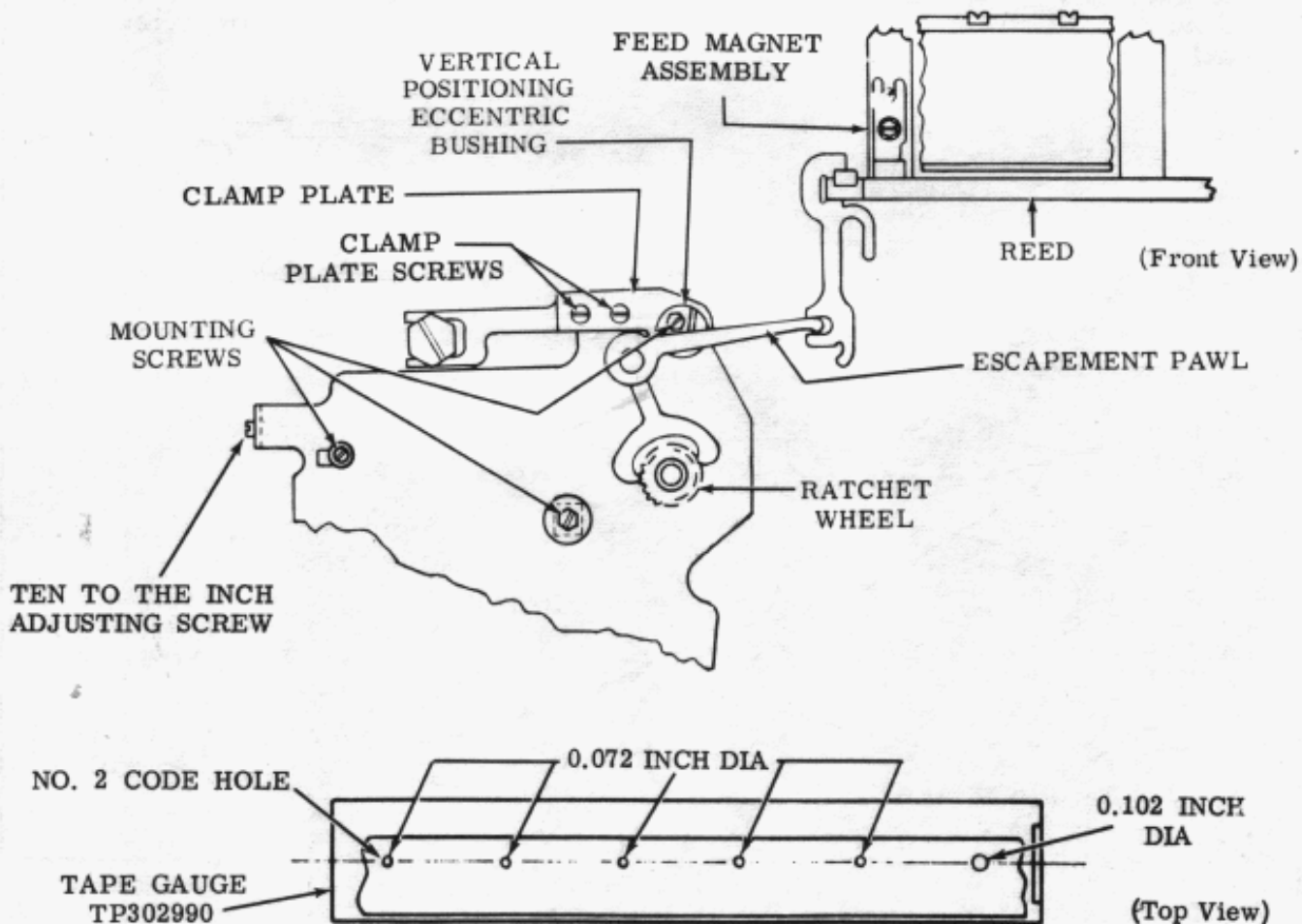

3.31 Punch Backup Mechanism (continued)

Note 1: Make this adjustment with punch backup mechanism installed.

REVERSE FEED WHEEL PHASING

Note 2: This adjustment is to assure that the tape will be backed-up exactly 80 characters.

(1) Requirement (Preliminary)

With ten to the inch requirement made, punch about one foot of fully perforated tape. Push tape guide assembly down by pressing at tape guide pivot post until reverse feed wheel pins just enter feed holes of tape. (Do not press any further.) Feed pins should be biased to right side of hole but should not distort tape at edge of hole.

(2) Requirement (Final)

Punch at least one foot of fully perforated tape. Initiate a back-up and overpunch tape. No feed hole should be distorted or elongated by more than 0.003 inch. Repeat procedure and check at least ten times.

To Adjust

With both detent disc mounting screws friction-tight and while holding detent roller firmly against detent disc, move feed wheel in direction required. Tighten mounting screws.

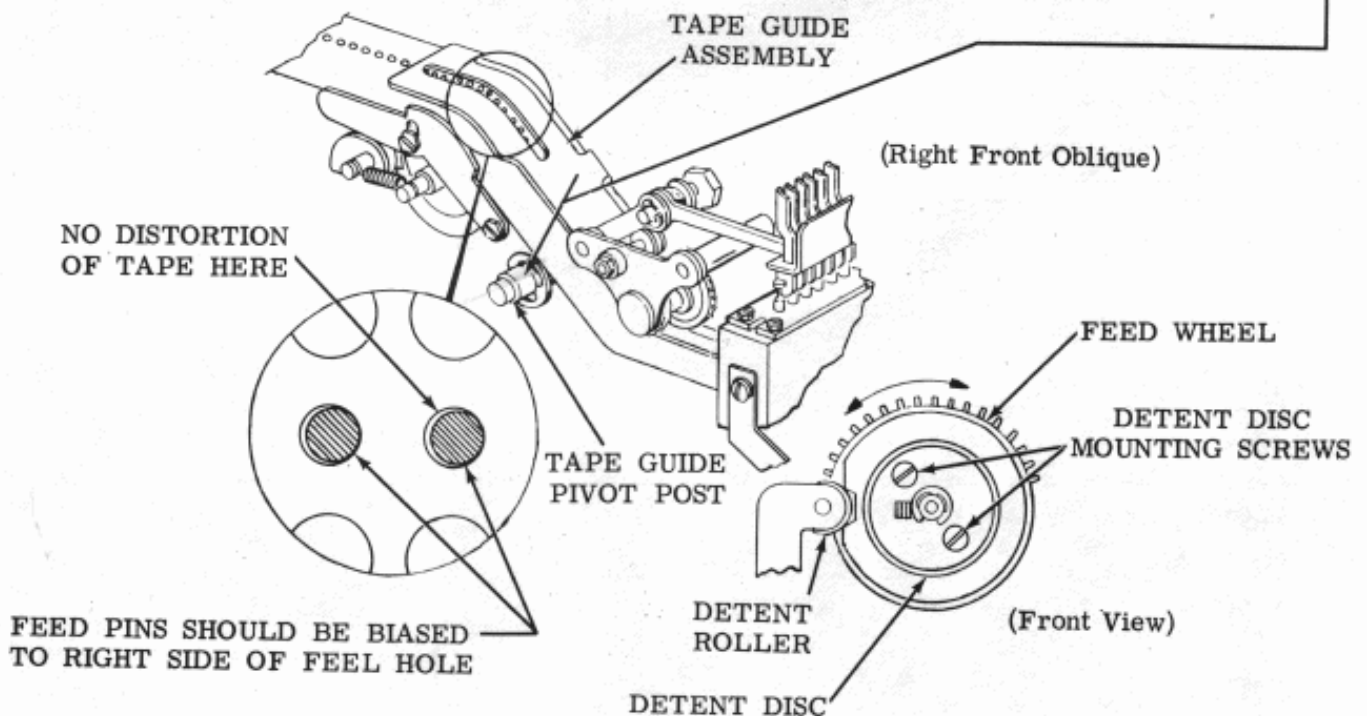

3.32 Punch Backup Mechanism (continued)

YIELD SPRING

Requirement

With spring scale positioned over feed pin and pulled to move feed wheel in a counterclockwise direction, it should require

Min 8 oz---Max 10 oz
to start feed wheel moving.

Note: Check with ratchet and feed wheel removed. See appropriate disassembly section for procedure. Hold ratchet and rotate feed wheel several times to make sure there is no binding after parts are assembled.

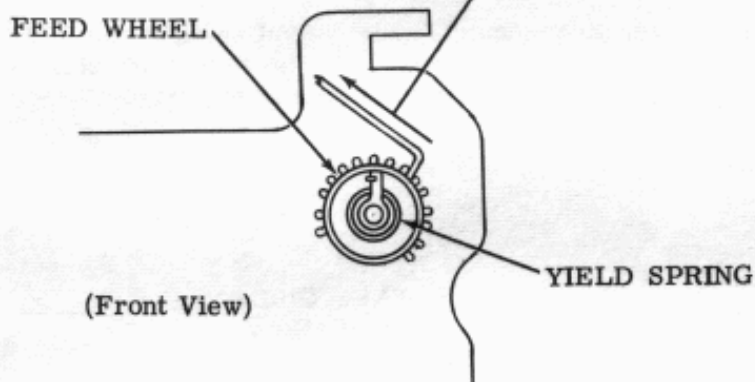

DETENT LEVER SPRING

Requirement

With drive shaft rotated until both clutches are disengaged, it should require

Min 7 oz---Max 9 oz
to start detent lever spring moving from its detent position.

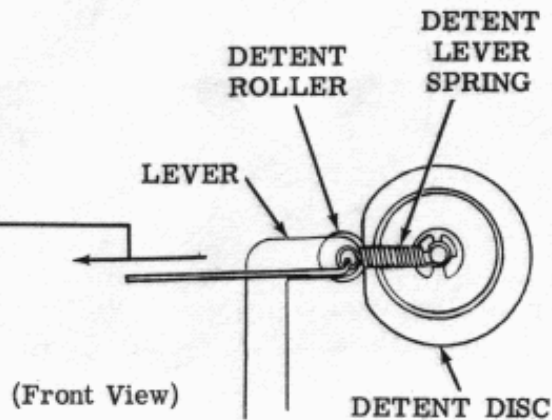

3.33 Punch Backup Mechanism (continued)

TAPE LID SWITCH LEVER SPRING

Requirement

With drive shaft rotated until both clutches are disengaged and spring removed from switch lever, it should require

— Min 7 oz---Max 10 oz
to pull spring to its operating length.

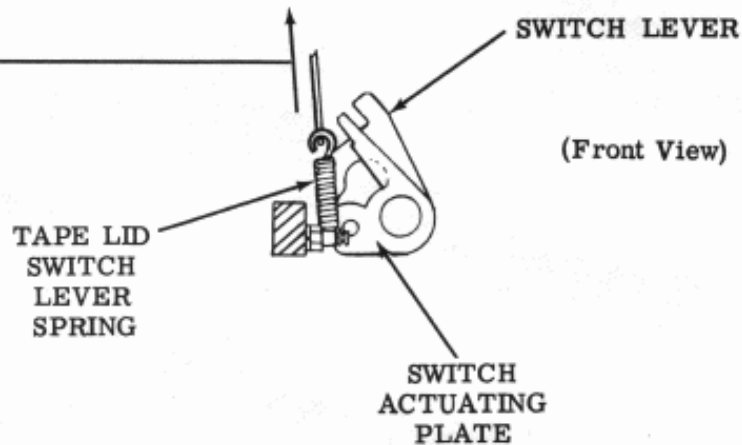
TAPE GUIDE CAM FOLLOWER ARM SPRING

Requirement

With drive shaft rotated until both clutches are disengaged, it should require

— Min 36 oz---Max 40 oz
to pull spring to its installed length.

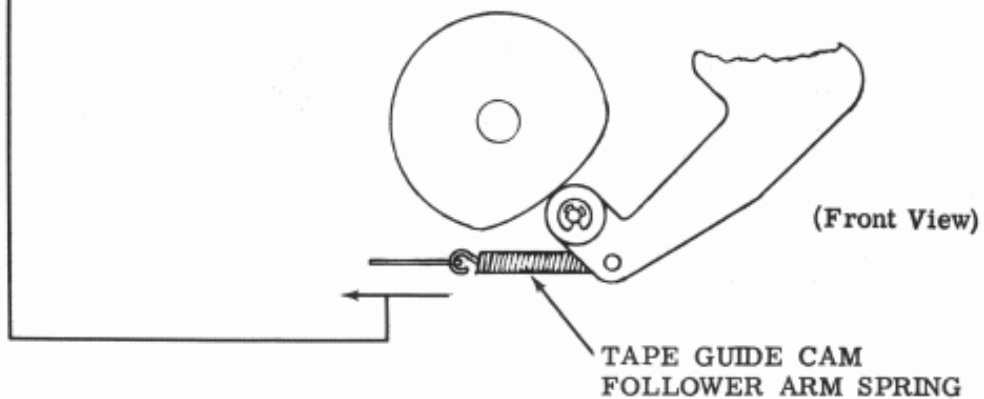

3.34 Punch Backup Mechanism (continued)

DRIVE SHAFT CLUTCH LATCHLEVER SPRING

Requirement

With trip magnet actuated and drive shaft rotated until disc lugs are clear of both stop lever and latchlever, it should require

Min 1-1/2 oz---Max 3-1/2 oz
to start lever moving.

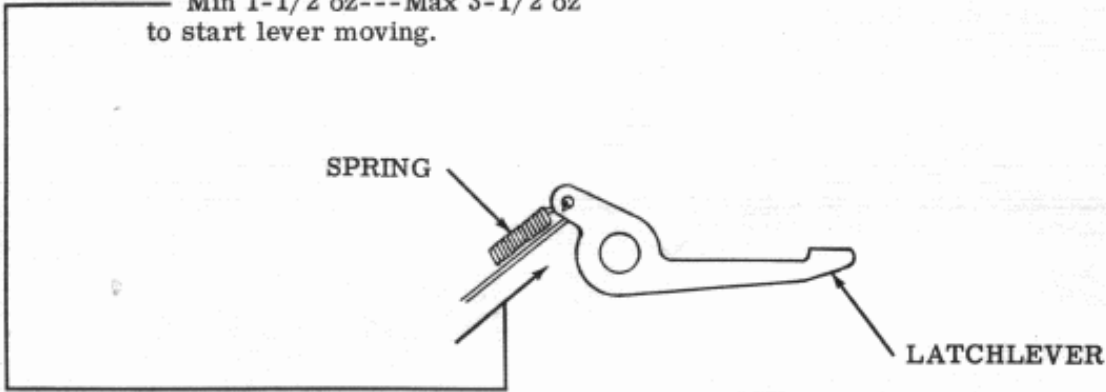

(Front View)

DRIVE SHAFT CLUTCH STOP LEVER SPRING

Requirement

With drive shaft rotated until both clutches disengage, it should require

Min 2 oz---Max 4 oz
to pull spring to its operating length.

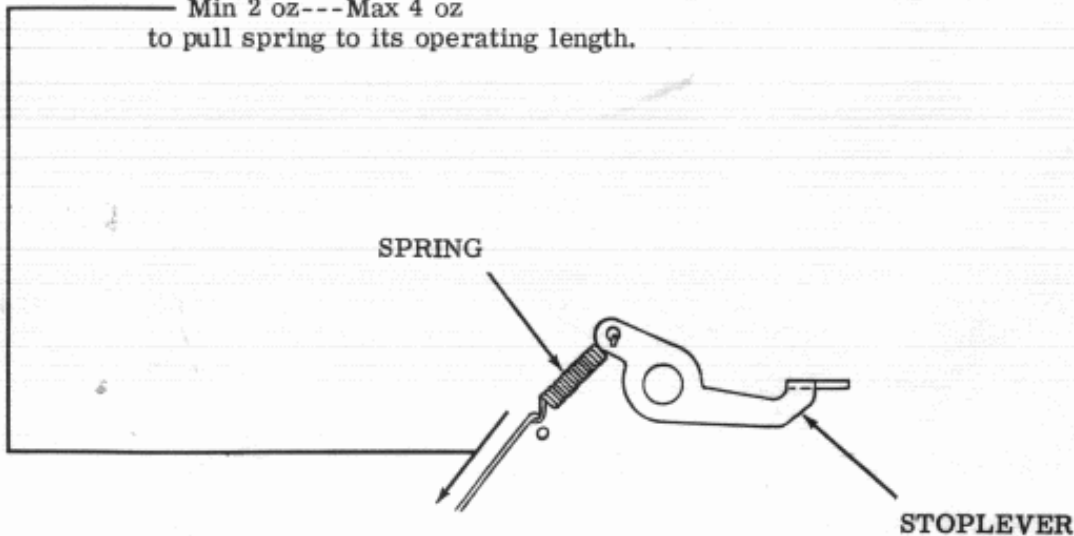

(Front View)

3.35 Punch Backup Mechanism (continued)

INTERMEDIATE SHAFT CLUTCH STOP LEVER SPRING

Requirement

With magnet actuated and drive shaft rotated until intermediate clutch engages and stop lever is against eccentric stop post, it should require

Min 1-1/2 oz---Max 3-1/2 oz
to start lever and shaft rotating away from eccentric stop post.

