



BULLETIN 249B
GENERAL DESCRIPTION
AND
THEORY OF OPERATION
MODEL 28
PERFORATOR TRANSMITTER
LAK, LPE, LAAC

TELETYPE[®]
CORPORATION
SUBSIDIARY OF *Western Electric Company* INC.
CHICAGO, ILLINOIS, U. S. A.



BULLETIN 249B
GENERAL DESCRIPTION
AND
THEORY OF OPERATION
MODEL 28
PERFORATOR TRANSMITTER
LAK, LPE, LAAC

TELETYPE[®]
CORPORATION
SUBSIDIARY OF *Western Electric Company* INC.
CHICAGO, ILLINOIS, U. S. A.

COPYRIGHT 1958 BY TELETYPE CORPORATION IN UNITED STATES. COPYRIGHT
IN ALL COUNTRIES PARTICIPATING IN INTERNATIONAL CONVENTION AND PAN
AMERICAN CONVENTIONS. ALL RIGHTS RESERVED INCLUDING RIGHTS OF TRANS-
LATIONS INTO ALL LANGUAGES.

PRINTED IN U.S.A.

The MODEL 28 AUTOMATIC SEND-RECEIVE SET (ASR) is made up of a group of basic component units in various combinations. These include a keyboard, page printer, perforator (typing or non-typing), reperforator (typing or non-typing), transmitter distributor, transmitter distributor base, electrical service unit, console cabinet and motor unit.

UNITS COVERED IN THIS BULLETIN

KEYBOARD..... LAK1, 2, 3, 4, 6 and 7
 PERFORATOR (NON - TYPING)..... LPE1 and 2
 PERFORATOR (TYPING)..... LTPE1
 TRANS. DIST. BASE..... LCXB1, 2, 3, 5, 6 and 7
 ELECTRICAL SERVICE UNIT..... LESU11, 13, 15, 21 and 22
 MOTOR UNIT..... LMU12
 CABINET..... LAAC200**, 201**, 202**, 205**
 207**, 209** and 210**

The following chart lists the numbers of bulletins covering components of the ASR set, such as, parts ordering (P), adjustments and lubrication (A&L), description and theory of operation (D&T). (Bell System refer to standardized A&L information)

PAGE PRINTER	LP Typing Unit	1149B (P) 216B (D&T) 217B (A&L)
KEYBOARD	* LAK Perforator Transmitter Base	1169B (P)
PERFORATOR OR REPERFORATOR	* LPE Non - typing Perforator	249B (D&T)
	* LTPE Typing Perforator	250B (A&L)
	LRPE Non - typing Reperforator	1172B (P) 256B (A&L)
	LPR Typing Reperforator	1167B (P) 246B (D&T) 247B (A&L)
BASE	* LCXB Transmitter Distributor Base	1169B (P)
TRANSMITTER DISTRIBUTOR	LXD Fixed Head, Single Contact Trans. Dist.	1161B (P) 235B (A&L)
	LAXD Pivoted Head, Multi - contact Trans. Dist.	1170B (P) 252B (A&L)
	LBXD Fixed Head, Multi - contact Trans. Dist.	1165B (P) 243B (A&L) 242B (D)
	LCXD Fixed Head and Pivoted Head, Multi - contact Trans. Dist.	1171B (P) 253B (D&T) 254B (A&L)
MOTOR	* LMU Motor Unit	1169B (P) 249B (D&T) 250B (A&L)
ELECTRICAL SERVICE UNIT	* LESU Electrical Service Unit	
CABINET	* LAAC Automatic Send - Receive Cabinet	
KEYTOP WITH LEVER AND TYPEPALLETS	Murray, Gothic, Long Gothic and Large Gothic Styles	1164B (P)
GEAR SETS <small>(For gears used with the LPR or LRPE see appropriate bulletin).</small>	*160675 Gear Set for 60 W.P.M. Speed Includes: 158084 Gear Set for Keyboard (LAK) and 158029 Gear Set for Base (LCXB)	1169B (P) 250B (A&L)
	*160676 Gear Set for 75 W.P.M. Speed Includes: 158082 Gear Set for Keyboard (LAK) and 158028 Gear Set for Base (LCXB)	
	*160677 Gear Set for 100 W.P.M. Speed Includes: 158080 Gear Set for Keyboard (LAK) and 158027 Gear Set for Base (LCXB)	

* Description and Theory of Operation of these components are covered in this bulletin.

NOTES:

1. See specification 58735 for installation instructions covering typical ASR sets.
2. See bulletin 10758 for parts ordering information and specification 58845 for adjustments and lubrication of TW13 Tape Winder used with some ASR cabinets.
3. See bulletin 11248 for ordering information on special tools.

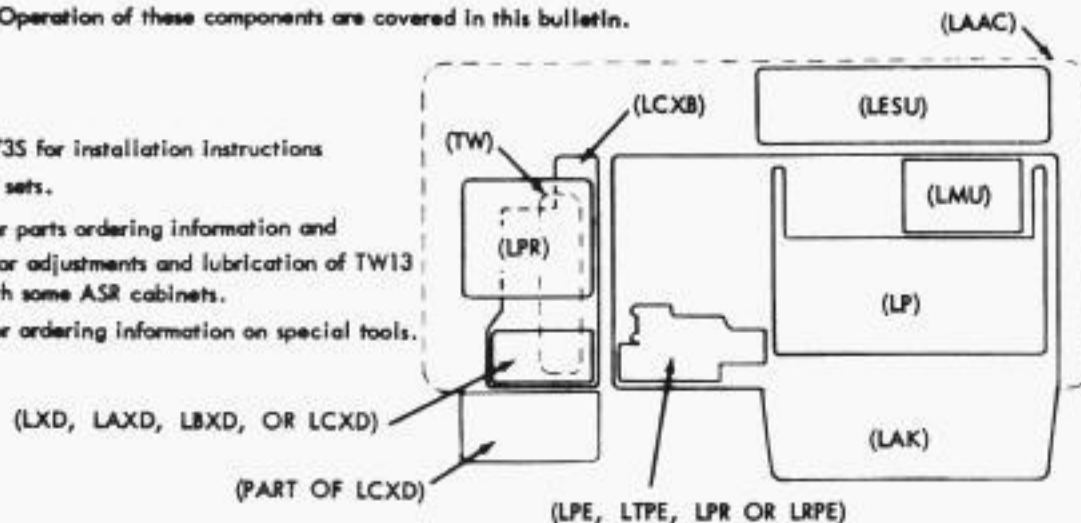

LIST OF EFFECTIVE PAGES

AUGUST, 1958

PAGE NUMBER	CHANGE IN EFFECT
Title Page	Original
A to E	Original
1-1 to 1-3	Original
2-1 to 2-8	Original
3-0 to 3-11	Original

The above list indicates the effective pages as of the date of issue. Upon receipt of change pages, insert them numerically and discard superseded pages.

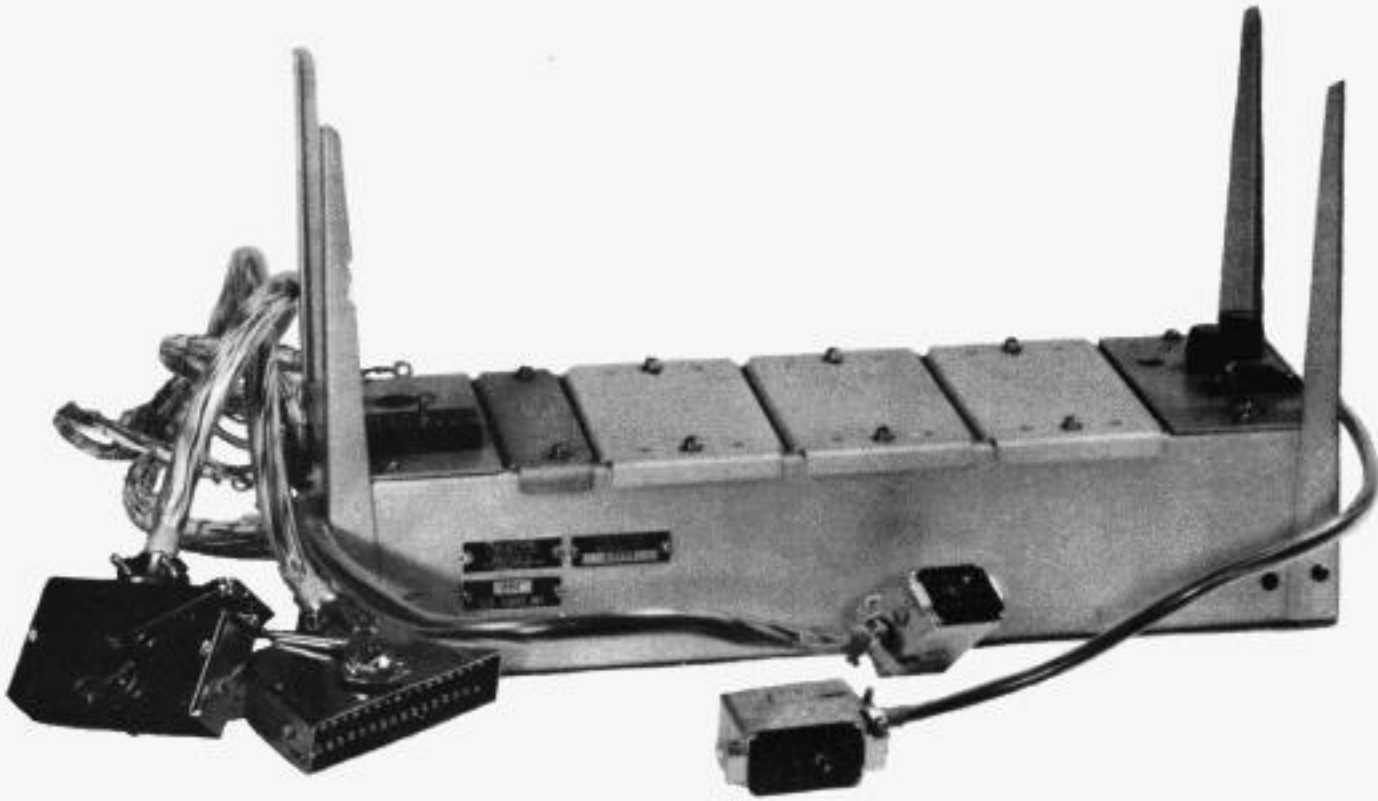

MODEL 28 ELECTRICAL SERVICE UNIT
LESU



MODEL 28 PERFORATOR TRANSMITTER
Mounted in
AUTOMATIC SEND-RECEIVE SET

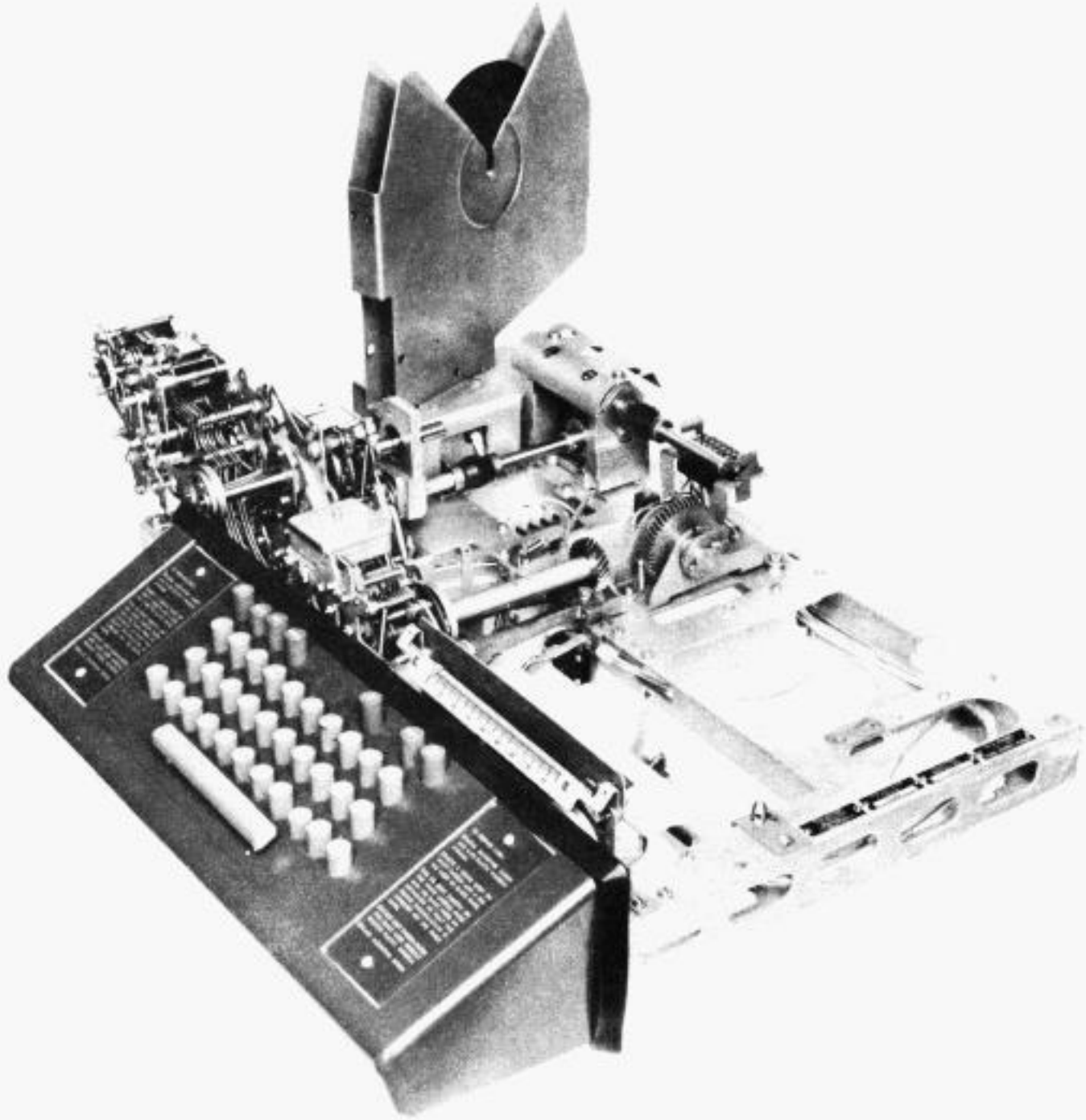

MODEL 28 PERFORATOR TRANSMITTER
(LAK with LPE)

TABLE OF CONTENTS

SECTION 1 - GENERAL DESCRIPTION

PARAGRAPH	PAGE
1. GENERAL	1-1
2. DESCRIPTION OF COMPONENTS	1-1
a. Base	1-1
b. Keyboard assembly	1-1
c. Signal generator	1-1
d. Reset cam follower bracket assembly	1-1
e. Code bar extension bracket assembly	1-2
f. Tape perforator	1-2
g. Tape supply container	1-2
h. Auxiliary electric switch	1-2
i. Character counter	1-2
3. CABINET	1-2
4. MOTOR	1-3
5. ELECTRICAL SERVICE UNIT	1-3

SECTION 2 - THEORY OF OPERATION

1. GENERAL	2-1
2. KEYBOARD	2-1
a. General	2-1
b. Code bar mechanism	2-1
c. Signal generator mechanism	2-2
d. Repeat mechanism	2-2
e. Electrical line break mechanism	2-3
f. Local line feed mechanism	2-3
g. Local paper feed out mechanism	2-3
h. Electrical keyboard lock mechanism	2-3
i. Keyboard unlock mechanism (send key)	2-3
j. Local carriage return mechanism	2-4
k. Margin indicator mechanism	2-4
l. Character counter mechanism	2-4
(1) General	2-4
(a) Stepping	2-4
(b) Counter reset	2-4
(c) Restart	2-4
(2) End of line switch	2-5
m. Auxiliary electric switch	2-5
n. Tape supply container	2-5
3. KEYBOARD-PERFORATOR LINKAGE MECHANISM	2-5
a. General	2-5
b. Operation in K position	2-5
c. Operation in K-T position	2-5
d. Operation in T position	2-6
4. PERFORATOR MECHANISM	2-7
a. General	2-7
b. Punch mechanism	2-7
c. Power drive backspace mechanism	2-7
d. Code reading contact mechanism	2-8
e. Auxiliary timing contact mechanism	2-8

SECTION 3 - FIGURES FOR SECTION 1 AND 2

SECTION 1
GENERAL DESCRIPTION

1. GENERAL

a. The Model 28 Perforator Transmitter Base (figure 1-1) provides means for transmitting coded electrical impulses to a signal line and/or controlling the perforation of tape for use in a tape transmitter. It is designed to support a Typing Unit, and a Motor Unit and to utilize a non-typing perforator (figure 1-1), a typing perforator, a non-typing reperforator or a typing reperforator.

b. A control switch permits operation as follows:

(1) Direct keyboard transmission with monitoring of the message by the typing unit.

(2) Direct keyboard transmission and simultaneous perforation of tape with monitoring of the message by the typing unit.

(3) Perforation of tape only, if either a non-typing perforator or a non-typing reperforator is used or, with utilization of a typing perforator or a typing reperforator, perforation of tape with the message printed thereon.

c. With direct keyboard transmission, linkage to the perforating mechanism is depressed to disassociate the punching mechanism from the keyboard operation. Under this condition, if a typing or non-typing reperforator is being used, circuitry can be established to permit the reperforator to receive incoming traffic from a second line circuit.

d. Several variable features, such as a character counter, electrical keyboard lock, code reading contacts, timing contacts, signal line break, tape backspace, and paper feedout motor start are available as optional features.

2. DESCRIPTION OF COMPONENTS

a. BASE. (See figure 1-2)

(1) The base is a reinforced aluminum sheet metal box frame on which all other assemblies are mounted.

b. KEYBOARD ASSEMBLY. (See figure 1-1)

(1) The keyboard assembly consists of a keylever guide assembly, front frame, guide plate, keylevers, and ball lock assembly.

(2) The keylever guide assembly accommodates all code and function levers.

c. SIGNAL GENERATOR. (See figure 1-2)

(1) The signal generator consists of a frame assembly; front and rear plate assemblies; gear, shaft, clutch and cam assembly; and a contact box assembly.

(2) The clutch stop and latch levers are mounted on the frame.

(3) The code bar assembly and non-repeat lever with its guide are mounted on the rear plate.

(4) The front plate acts as a mount for the detent plate assembly; transfer bail and stud; transfer levers with their guides, springs, and mounting studs; and the locking bail with its stud and spring.

(5) The cam, clutch, and shaft assembly is mounted between the front and rear plates. The cam is one piece of machined steel with eight lobes. The seven lobes which generate pulse signals, are equal in contour and are positioned at uniform angles with one another. The eighth lobe differs in contour, and is used to actuate the transfer lever locking bail.

(6) The universal bail latch lever with its eccentric bushing is fastened to the right front of the frame. This latch lever extends to the rear over the code bar bail latch and the non-repeat lever pawl.

(7) The contact box assembly is mounted on the front plate. It is composed of a fibre insulating strip, a contact toggle assembly and phenolic base, drive link, and an arc suppressor, or RF, unit.

d. RESET CAM FOLLOWER BRACKET ASSEMBLY. (See figure 1-2)

(1) This assembly consists of a hollow shaft with internal oilite bearings pivoting on a fixed shaft.

(2) A hooked arm on one end of the hollow shaft connects the hollow shaft to the clutch trip bar assembly.

(3) An adjustable arm and roller on the other end of the hollow shaft follows the reset cam on the perforator main shaft.

(4) The entire assembly provides linkage between the clutch trip bar and the perforator cam in TAPE position, thereby permitting the

keyboard to be reset at high speeds.

e. CODE BAR EXTENSION BASKET ASSEMBLY. (See figure 1-3)

(1) This assembly consists of the following major components:

(a) The code bar extensions which are used to transmit character information from the keyboard to the punch.

(b) The clutch trip bar extension which links the clutch trip bar to the perforator clutch trip lever extension in K-T and T positions.

(c) The code bar extension blocking bail, which blocks the selection of code bar extensions and character counter code bars in the K position. It also prevents the perforator clutch from being tripped in K position.

(d) The selector lever assembly, which permits the signal generator clutch to be tripped in K and K-T positions. It also prevents the signal generator from being tripped in T position.

(e) The control cam, which drives the auxiliary electric switch and provides the K, K-T and T operations of the perforator transmitter.

(2) The primary purpose of the code bar extension basket assembly is to transmit character information from the keyboard code bars to the perforator, and to serve as control center for the various functions of the Model 28 perforator transmitter base.

f. TAPE PERFORATOR. (See figure 1-2)

(1) This assembly consists of a drive assembly, transfer mechanism, punch mechanism, backspace mechanism, code reading contacts, and auxiliary timing contacts. All these mechanisms are mounted individually on one sub-base.

(2) Two drive shafts are used:

(a) The main shaft, consisting of a cam and two-cycle function clutch.

(b) The lower function clutch driving shaft.

(3) The backspace mechanism is used to backspace tape to permit correction of an erroneous character or characters in the tape. The tape is backspaced until the first erroneous character is over the punch pins. The letters keylever is then operated to rubout (that is, to re-perforate with the letters code combination)

the erroneous character in the tape and all characters that follow.

(4) The five code reading contacts are associated with punch slides and read the code combinations which are being perforated.

(5) The auxiliary timing contacts provide synchronizing pulses for the code reading contacts.

g. TAPE SUPPLY CONTAINER. (See figure 1-1)

(1) This container is mounted on a bracket over the auxiliary electric switch housing.

(2) The operator has access to it through a special door without raising the hood.

h. AUXILIARY ELECTRIC SWITCH. (See figure 1-1)

(1) This multiple circuit switch is enclosed in a housing that acts as a dust and electrostatic shield.

(2) The housing is located under the tape supply container.

i. CHARACTER COUNTER. (See figure 1-1)

(1) This assembly is mounted on the right front of the base, and is operated by the character counter code bars.

(2) The counter steps along its horizontal scale for any character or space in T and K-T positions. It is reset when the carriage return key is struck.

3. CABINET

a. The sheet metal cabinet is designed to house the various other units of the Automatic Send-Receive Set. It is 38-1/2 inches high, 36 inches wide and 18 5/16 inches deep. It weighs approximately 200 pounds. The upper portion forms a compartment for housing a keyboard, typing unit, perforator, or re-perforator, a transmitter distributor with base, a motor and shafting for driving the units, and an electrical service unit. It may also house an auxiliary re-perforator.

b. The dome, which extends completely across the cabinet and is hinged at the rear, is partially raised by two torsion bars when the dome latches are released. Small doors are provided in the dome to provide access to the

units without raising the dome. At the top right end of the dome a small door is provided for access to the rear of the typing unit when changing paper rolls. A window in front of the typing unit position provides a view of the platen, type box and the line which is being typed. The rear edge of the window serves as a means for tearing off printed copy. This window may be opened for changing ribbon or straightening paper. A top-center door provides access to the tape reel for reloading. At front center a lid is provided for access to the perforator mechanism for threading tape and ribbon. At the left end of the dome another door is provided for access to an auxiliary reperforator when included in the set. On the left front surface of the dome a removable blank panel is provided. This panel may be replaced by a control panel if desired. Copylights with switch are provided in the dome to illuminate the page copy in the printer and the tape in the perforator. Two lamp lenses are provided in the dome, one at right end for end-of-line indicator, and one near the center which may be used for a busy light or similar device.

c. Terminal boards on which all apparatus and cabinet wiring terminates are located across the back panel of the cabinet.

d. A shell separates the upper portion from the lower portion and serves as the mounting place for the apparatus. A signal bell is mounted to the bottom side of the shelf. An electrical service unit, electrical noise suppressor (if used), and a cradle assembly are mounted to the top side of the shelf. The cradle assembly is mounted on vibration dampeners. A switch lever for controlling the power switch on the electrical service unit is mounted at the right end of the shelf, and extends through the cabinet underneath the right end of the keyboard. Provisions are made on the cabinet underneath the left end of the keyboard for mounting a similar lever to control a line test key.

e. Other provisions have been made in the lower portion of the cabinet for a relay compartment, a tape winder, and tape bin with a motor driven tape stuffer. Adjustable feet which provide as much as one inch elevation are available.

4. SYNCHRONOUS MOTOR UNIT

a. Motion for operating the Automatic Send-Receive Set is provided by a 1/12 H. P. 115 Volt 60 cycle A.C., single phase, capacitor start, synchronous motor which runs at 3600 RPM.

The motor has a two pole wound stator and a squirrel cage type rotor which is mounted on ball bearings.

b. The stator has a starting winding and a running winding. The starting winding is in series with a 170MF A.C. electrolytic capacitor and with the current operated starting relay.

c. The capacitor and relay together with a thermal cutout switch are mounted in a compartment under the motor. The manual-reset thermal cutout switch serves to protect the motor windings from excessive heating.

d. The motor proper is supported by a cradle to which it is held by straps at each end. Resilient mounts on the hubs of the motor end bells reduce transmission of vibration. A combination handwheel and fan is mounted on one end of the motor shaft. The motor shaft turns in a counterclockwise direction as viewed from the fan end.

e. Input Current:

(1) Starting	12.25 amps.	
(2) Running	No load	2.48 amps.
	Full load	2.58 amps.
(3) Watts Input:	No load	66.3 Watts
	Full load	132.9 Watts

5. ELECTRICAL SERVICE UNIT

a. The basic part of the electrical service unit consists of a sheet metal structure which is mounted at the rear of the keyboard in the apparatus cabinet. This unit serves as an interconnecting point for the wiring from the other units of the set. It incorporates receptacles, fuses, switches etc. which are associated with the power and signal line circuits. A complete unit consists of:

- (1) Rectifier assembly
- (2) Signal line relay mounting assembly
- (3) Line test key assembly

(4) Provisions for mounting an electrical motor control.

b. The power switch and line test key in the electrical service unit are located so as to be operated from the front of the cabinet by means of switch levers.

SECTION 2
THEORY OF OPERATION

1. GENERAL

a. This section covers the operating principles of the Model 28 Perforator Transmitter Base. This equipment provides, in one unit, the functions of manual signal generation and high speed tape perforation. Three modes of operation are provided. Selection of the desired mode is made by a three-position keyboard control knob mounted at the left front of the base. These operating positions are:

(1) K (KEYBOARD). - In this position, signals only are generated by the keyboard. The tape perforator is inoperative.

(2) K-T (KEYBOARD-TAPE). - In this position, signals are generated by the keyboard and tape is perforated by the tape perforator simultaneously.

(3) T (TAPE). - In this position, tape is perforated at high speed by the tape perforator with no signal generation.

b. Maximum keyboard speeds are 368, 460 and 600 operations per minute (OPM) in the K and K-T positions. In the T position, maximum speed is 900 OPM. These speeds are for a 5-unit start-stop code (7.42 basis).

NOTE

In the illustrative drawings, fixed pivot points are indicated as solid black circles. Movable pivot points are indicated as cross-hatched circles.

2. KEYBOARD

a. GENERAL. - The keyboard mechanism and optional features are mounted on the base. These mechanisms include the intermediate gear, code bar mechanism with keylevers, signal generator mechanism, various function mechanisms and a character counter mechanism. Necessary circuitry is brought out to a connector mounted at the left rear of the base. The signal generator shaft, through a helical gear on the rear of the shaft, is operated by the main shaft of the typing unit which, in turn, derives its power from the motor unit.

b. CODE BAR MECHANISM.

(1) The code bar mechanism is located on the front underside portion of the keyboard. Each keylever in the lower three rows and the space bar is connected to a code lever and each

keylever in the upper row is connected to a function lever.

(2) The code and function levers pivot about points near their midportions (figure 2-1). Located above the rear half of the code levers and running parallel with the keyboard are, from rear to front, the clutch trip bar, the numbers 1, 2, 3, 4 and 5 code bars, two character counter bars (counter and carriage return), and the lock bar. The rear portion of each code lever or function lever is normally held downward by a spring so that the front end, with its attached keylever, is held upward.

(3) A wedgelock is mounted on the projection of the lower front portion of all code levers (figure 2-2). If one of these levers is operated, its wedgelock moves downward between the lock balls in the lock ball channel and crowds them together. This prevents any other lever with a wedgelock from being operated at the same time.

(4) With the signal generator shaft in its stop position, the code bars and clutch bar are held toward the left (viewed from the front) against the tension of their springs by the latched-up code bar bail.

(5) When any keylever in the three lower rows or the space bar is depressed, the rear end of the associated code lever engages and rotates the code lever universal bail counterclockwise (see figure 2-1). The extension on the code lever universal bail disengages from the step at the rear of the universal bail latch lever. This lever then moves downward under the tension of its spring. As the lever falls, it strikes the code bar bail latch and carries it downward (figure 2-3). When the corner of the code bar bail latch falls beyond the centerline of the needle bearing mounted on the code bar bail, the code bar bail is released and swings to the right.

(6) Upon being freed, the code bar bail, the clutch trip bar, and the selected code bars are pulled to the right by their springs. Unselected code bars are stopped from moving to the right by the operated keylever or space bar. For example, if the L lever is depressed, code bars 1, 3 and 4 will be stopped by the code lever engaging teeth on the underside of the code bars. The teeth on the code bars 2 and 5 are omitted in this area and the bars are permitted to move to their extreme right hand position (figure 2-4).

(7) The code bars have vertical extensions that engage a curved part of the signal generator transfer levers (figure 2-5). The code bars

which are permitted to move to the right carry with them their respective transfer levers.

(8) Simultaneously with the above operation, the clutch trip bar moves to the right. A keyboard control selection lever (figure 2-19) is linked to and moves to the right with the clutch trip bar. When the three-position keyboard control knob is in the K or K-T position (paragraph 3 b and c), a projection on the keyboard control selection lever trips the signal generator clutch stop lever. The clutch then engages and rotates the signal generator cam.

(9) Operation to this point is manual, resulting only from depressing a code lever or space bar. The remainder of the operating cycle is covered in paragraph c. below.

c. SIGNAL GENERATOR MECHANISM.

(1) When the clutch stop lever is tripped (paragraph b. (8) above), the clutch shoes engage a serrated surface on the inside of the clutch drum. When power is on (motor unit operating), the clutch drum rotates continuously in a clockwise direction (viewed from the front) because it is a part of the geared signal generator shaft. Since the clutch shoes are mounted on a plate that is part of the cam assembly, the cam rotates upon engagement of the clutch.

(2) As was shown in paragraph b. (7) above, each of the five code bars operates its own transfer lever (figure 2-5). In addition to these five transfer levers, there are two others which are not associated with code bars. These are used to originate the start and stop pulses.

(3) The cam lobes are numbered from 1 to 8 from rear to front. There are seven signal-pulse lobes on the cam (one for each transfer lever). The eighth cam lobe is used to actuate the locking bail.

(4) The cam lobes are arranged so that when the cam rotates, lobe 3 engages its transfer lever first and moves it downward. Almost at the same time, the eighth lobe from the rear begins to move the locking bail upward. A blade on the locking bail engages in slots on the selected transfer levers and locks them in position. Unselected transfer levers are locked in the left position as the blade blocks their movement. Thus, in the first few degrees of cam rotation, the permutated position of the transfer lever is locked and the code bars are free to be reset in their normal latched positions.

(5) Transfer lever 3 is the start pulse transfer lever. There is no code bar to engage this lever, hence it is always held to the left

by its spring. As cam lobe 3 moves this lever down, the hook on the upper right of the lever engages the right hand side of the transfer bail. This trips the transfer bail to the right and pulls the contact drive link (figure 2-5) to the right. The resulting action of the contact toggle is such that the marking contacts open and the spacing contacts close. Under this condition there is "no current" in the signal circuit. This is known as a spacing pulse. Thus, the first pulse (or start pulse) of any character is a spacing (no current) pulse.

(6) Lobe 1 and its transfer lever move downward next. For the character L it has been shown (paragraph b (6) above) that transfer lever 1 is positioned to the right. In turn, the upper left hook of this lever pulls downward on the transfer bail, tilting it back to the left. This pushes the drive link to the left, thereby closing the marking contacts and allowing a marking (current on) pulse to be transmitted.

(7) Similarly, transfer levers 2, 4, 5, and 6 are pulled downward by their respective cam lobes. The resulting pulse will be marking if the transfer lever is to the right, or spacing if it is to the left.

(8) Transfer lever 7 is the stop pulse transfer lever. This lever is permanently held to the right by a stop pin; therefore, the resulting pulse, the stop pulse, is always marking (current on).

(9) The locking bail holds the transfer levers in their permutated positions until after the beginning of the fifth pulse. Then cam lobe 8 pulls the bail down out of locking position and all selected transfer levers are free to return to their left position.

(10) Reset of the code bars is accomplished by means of an eccentric on the front of the cam, which drives an eccentric follower (figure 2-3). The follower engages an eccentric stud on the side of the code bar bail and pulls the bail to the left as the cam rotates. As the code bar bail moves to the left, the code bar bail latch clears the needle bearing stud and is pulled upward into locking position under tension of the spring to latch or reset the code bar bail. As the code bar bail is moved into reset position, it engages projections on the permutated code bars, clutch trip bar, and a stop on the non-repeat lever, thus moving all these elements to the left into latched reset position.

d. REPEAT MECHANISM. - Operation of the REPT keylever simultaneously with one of the keylevers in the three lower rows or the space bar disables the non-repeat mechanism and

causes the character or function selected to be repeated as long as the REPT keylever is held operated. The operated REPT keylever causes its function lever to raise the right end of the non-repeat lever (figure 2-6) and rotates it about its pivot point. In this position, the non-repeat lever cannot be engaged and operated by the code bar bail, therefore, the non-repeat lever crank will not reset the operated code bar bail latch. The code bar bail and universal bail latch lever are thus maintained in their operated positions and the code bar bail follows the eccentric arm movement back and forth until the REPT keylever is released.

e. **ELECTRICAL LINE BREAK MECHANISM.** (See figure 2-7) - The electrical line break mechanism provides a means of interrupting signal line current for use as a break signal. Interruption of the line current is effected by depressing the BREAK keylever located on the keyboard. This is accomplished as follows:

(1) When the BREAK keylever is depressed, its function lever pivots and raises the front end of the break lever. The rear portion of the break lever depresses the actuator pin of the sensitive switch, which open the normally closed contacts. This action breaks the continuity of the signal line circuit, causing a break signal (no current) to be transmitted.

(2) When the BREAK keylever is released, the tensions of the switch spring and break lever spring cause the function lever to return the keylever to its normal position and the switch contacts to their normally closed condition.

f. **LOCAL LINE FEED MECHANISM.** (See figure 2-8) - When the LOC. LF keylever on the keyboard is depressed, paper is fed out of the associated typing unit when power is on. The mechanism operates as follows: Depressing the LOC. LF keylever raises the forward end of the local line feed bail. This bail pivots and its upper end pushes the attached local line feed trip link toward the rear until the link engages the line feed clutch trip lever on the typing unit. Thus, the line feed mechanism on the local typing unit is made to operate without a signal and other typing units on the same line circuit are not disturbed.

g. **LOCAL PAPER FEED OUT MECHANISM.** (See figure 2-9) - The local paper feed out mechanism enables the operator to feed out copy paper by depressing the local line feed keylever, whether the printer set is on or off. The mechanism operates as follows:

(1) Depressing the LOC. LF keylever causes the local line feed trip link to move to

the rear and unlatch the line feed clutch trip lever, as described in paragraph f. above. If the set is operating, the result is that copy paper is fed out until the LOC. LF keylever is released. If the set is not operating, the line feed clutch of the typing unit is conditioned to operate when the power is supplied.

(2) When the local line feed trip link is fully actuated, it rotates the local paper feed-out switch lever, releasing the switch plunger and permitting the contacts in the magnetic blow-out switch to close.

(3) This actuates the motor circuit of the printer so that the motor will run and eject copy paper as long as the LOC. LF keylever is depressed (printer normally off).

h. **ELECTRICAL KEYBOARD LOCK MECHANISM.** (See figure 1-3) - The electrical keyboard lock mechanism permits the signal generator contact to be electrically shunted from the keyboard or from the associated typing unit shunt. This mechanism operates as follows:

(1) To shunt the keyboard locally, depress the REC keylever (See figure 2-10). This action raises the keyboard lock function lever which, in turn, raises the lock bar latch. With the lock bar latch disengaged, the lock bar is free to move to the right under spring tension of the keyboard lock switch contact on the switch lever (See figure 2-10). The switch lever then pivots, closing the contacts of the switch. The associated circuitry is arranged to shunt the signal generator when the switch is closed. However, since there is no mechanical blocking of the keylevers, the perforator transmitter can still be operated as a tape perforator.

(2) The keyboard can also be shunted when two consecutive blank code signals are received by the associated typing unit. Under this condition, the keyboard lock lever on the typing unit (figure 2-10) moves downward and depresses the keyboard lock plunger. This movement causes the keyboard lock bail to pivot and raise the keyboard lock function lever. This disengages the lock bar latch and the keyboard is shunted as described in (1) above.

i. **KEYBOARD UNLOCK MECHANISM (SEND KEY).** - The keyboard unlock mechanism permits the keyboard to be unshunted. The operation of the mechanism is as follows:

(1) When the SEND keylever is depressed (See figure 2-11), the keyboard unlock function lever rises against a diagonal camming surface on the lock bar (See figure 2-10). This moves the lock bar to the left until the lock bar latch

falls into a notch on the lock bar.

(2) As the lock bar moves to the left, the switch lever (See figure 2-11) pivots and opens the contacts of the keyboard lock switch. The associated circuitry is arranged so that, when the switch contacts open, the signal generator is no longer shunted (paragraph h. above) and normal signal transmission can take place.

j. LOCAL CARRIAGE RETURN MECHANISM. - The local carriage return mechanism enables the operator to trip the carriage return mechanism on the associated typing unit, thereby causing the type box carriage to be fully returned to its normal position at the beginning of a line of copy. This mechanism operates as follows: When the LOC. CR keylever (figure 2-12) is depressed, its function lever rises and, in turn, raises the forward end of the local carriage return bail. This bail rotates about its pivot point until the upper end engages the carriage return lever on the typing unit. The carriage return mechanism operates in this manner without a signal that would cause other units in the line circuit to function.

k. MARGIN INDICATOR MECHANISM. (See figure 2-13) - The margin indicator cam disk on the associated typing unit spring drum rotates with the drum as spacing occurs. As the end of each line is approached, the cam surface of the disk makes contact with the margin indicator contact switch lever and rotates it clockwise about its pivot point. When the lever rotates, it releases the margin indicator switch plunger. The normally open contacts are closed, completing the circuit to a margin indicator light in the cabinet. The carriage return cycle returns the cam disk to its starting position and the margin indicator switch opens. The switch is operative only when the keyboard is in the K and K-T positions (See paragraph l (2) below).

1. CHARACTER COUNTER MECHANISM. - (See figures 2-14 and 2-15)

(1) GENERAL. - The character counter is driven mechanically from the perforator transmitter by the action of the counter and carriage return code bars located in the second and third slots of the code bar basket. These bars provide drive projections which engage the forks of the feed and reset bails of the counter. As the code bars fall to the right when a key on the keyboard is struck, the counter mechanism is tripped. As the keyboard is reset under power, the counter performs its required functions. These functions may be divided into three distinct phases of operation. Figure 2-16 illustrates these three phases of operation and also the normal position of the counter mechanism.

(a) STEPPING. - Referring to sequence A, figure 2-16, as a key is struck the code bars fall to the right, carrying with it feed bail 1. The drive lever, which is linked to the feed bail, moves to the left slightly more than one tooth. As the code bars are reset under power, stepping bail 1 moves clockwise, causing the drive lever to advance the ratchet drum one tooth. The drive pawl prevents the ratchet drum from rotating counterclockwise until it is again tripped for the following character. When this occurs the ratchet drum rotates slightly counterclockwise, coming to rest against the latch lever.

(b) COUNTER RESET.

1. Sequence B, figure 2-16, illustrates the tripped position of the counter mechanism for a reset function. Reset bail 2 moves counterclockwise as its code bar falls to the right, causing the reset lever in turn to rotate clockwise. As the reset lever rotates clockwise the reset lever extension moves downward until it falls under the shoulder of the projection on the drive and latch levers under the action of its spring. When the counter bars are reset as in C, figure 2-16, the reset bail is rotated clockwise to its original position, causing the reset lever to rotate counterclockwise, carrying the reset lever extension upward, and moving both the drive and latch levers out of engagement with the ratchet teeth. The mechanism remains in this condition and the ratchet drum assembly rotates rapidly counterclockwise (under the action of its return spring) until it reaches its zero position.

2. As the ratchet drum reaches its zero position, a stop on the ratchet strikes a stop lever fastened to the frame. The elastic impact is transmitted through the stop lever to the anti-bounce lever whose lower end is normally in contact with the stop lever. The anti-bounce lever rotates counterclockwise, dropping in behind the ratchet stop. As the ratchet drum rebounds from the stop lever, its stop strikes the anti-bounce lever, preventing further motion and maintaining the anti-bounce lever in its actuated position. The ratchet continues to operate between the stop lever and anti-bounce lever until the energy in the system has been largely dissipated. The ratchet stop then remains in contact with the stop lever, permitting the anti-bounce lever to return to its normal position.

(c) RESTART. - Sequence D, figure 2-16, illustrates the restarting action of the counter mechanism for the character following a carriage return. As a key on the keyboard is depressed, the counter code bar falls to the right, the feed bail moves counterclockwise and the drive lever moves to the left. As the drive lever moves to the left it is disengaged from the reset

lever extension and falls into engagement with the ratchet tooth. As the code bars are reset under power, the feed bail rotates clockwise and the feed lever begins to move to the right. As it does, its projection pushes the reset lever extension to the right and out of engagement with the latch lever, which falls into engagement with the ratchet drum. As the drive lever completes its stroke, it steps the ratchet one tooth as in the normal stepping operation.

(2) END-OF-LINE SWITCH. - (See figure 2-14)

(a) The end-of-line switch operates the end-of-line indicator light located in the cabinet to signal the end of a typed page printer line. The switch circuit is operative only when the keyboard is in the T position. In the K and K-T operating positions, the end-of-line indicator light is operated by the margin indicator switch (paragraph 2 k). Selection of either the end-of-line indicator switch or margin indicator switch is automatically controlled by a keyboard control selection switch (figure 2-19). The selection switch is, in turn, operated by the keyboard control knob.

(b) Operation of the character counter end-of-line indicator switch is controlled by a switch cam (figure 2-14). The switch cam rotates with the ratchet drum and can be adjusted to close the switch at any typed line length of from 10 to 80 characters.

m. AUXILIARY ELECTRIC SWITCH. (See figure 1-1) - This switch is of the multi-circuit type. Operation of the switch is controlled by the keyboard control knob through a shaft and gears. The switch is used for various switching requirements not applicable to this bulletin.

n. TAPE SUPPLY CONTAINER. (See figure 1-1) - The tape supply container supplies the tape to the punch. The tape is guided from the container so that it traverses the punch from right to left (viewed from the front). A low-tape switch mechanism is available, as an optional feature, with the container to initiate a signal when the supply of tape is low.

3. KEYBOARD-PERFORATOR LINKAGE MECHANISM (See figure 2-17)

a. GENERAL. - The keyboard-perforator linkage consists principally of a code bar extension basket mechanism and reset cam follower bracket mechanism. The functions of the code bar extension basket mechanism are to transmit character information from the keyboard code bars to the perforator and to control the operation of the perforator transmitter in the K, K-T, and T positions. The reset cam follower mechanism

provides the linkage between the clutch trip bar and the perforator cam in the T position to permit the keyboard to be reset at high speeds by the tape perforator.

b. OPERATION IN K POSITION. - In this position signals are generated by the keyboard as described in paragraph 2 and the perforator is inoperative. This mode of operation is set up by turning the keyboard control knob to the K position. This conditions the keyboard-perforator linkage as follows:

(1) When the keyboard control knob (figure 2-17) is turned to the K position, the blocking bail shown in the illustration is moved to the left to the dotted position by the action of the control cam. When a code bar is selected and falls to the right, the code bar extension is prevented from moving to the right by the blocking bail and, therefore, information is not transmitted to the punch. An extension on the blocking bail also prevents selection of the character counter code bars (paragraph 2 L.).

(2) As the blocking bail moves to the left, a second extension (figure 2-18) engages a bell crank and pivots the bell crank clockwise. This disengages the latch from the clutch trip bar link so that, as the clutch trip bar falls to the right, the clutch trip bar link remains in the position shown and the perforator clutch is not tripped.

(3) The keyboard control selection lever (figure 2-19) is pivoted counterclockwise so that its pin at point B is free of the hook on the reset lever of the reset cam follower mechanism. At the same time, the extension on the right end of the keyboard control selection lever moves up to the dotted position shown at C so that, as the clutch trip bar falls to the right, the extension strikes the signal generator clutch trip lever, operating the signal generator mechanism.

c. OPERATION IN K-T POSITION. - In this position, signals are generated by the keyboard and tape is simultaneously perforated. This mode of operation is set up by turning the keyboard control knob to the K-T position. This conditions the keyboard-perforator linkage as follows:

(1) When the keyboard control knob is moved to the K-T position, the blocking bail shown in figure 2-17 moves to the right, releasing the code bar extensions and character counter code bars. The bell crank (figure 2-18) pivots counterclockwise, allowing the latch to engage the clutch trip bar link.

(2) The keyboard control selection lever

(figure 2-19) remains in its counterclockwise position so that it is not engaged by the reset lever of the reset cam follower but is still in position to trip the signal generator clutch trip lever.

(3) The character counter code bars are released so that the character will count; however, its end-of-line switch is inoperative due to the position of the keyboard control selection switch (figure 2-19). Refer to paragraph 2 L. for a description of the control switch operation.

(4) When a code keylever is depressed, the clutch trip bar falls and the following sequence takes place:

(a) The code bar bail and clutch trip bar move to the right, thereby releasing the selected code bars. The selected code bars and associated code bar extensions (figure 2-17) move to the right. As the code bar extensions move to the right, they engage their associated punch slide latches at C, causing the punch slide latches to rotate counterclockwise and unlock the punch slides at B.

(b) The clutch trip bar link (figure 2-18) is pulled to the right by the clutch trip bar. The clutch trip bar link is coupled to the perforator trip lever latch. This latch contacts the perforator trip lever at B, causing it to rotate counterclockwise. As it moves counterclockwise, the perforator trip lever is disengaged from the clutch release at A. The clutch release falls under spring tension and releases the perforator clutch trip lever which, in turn, trips the perforator clutch. The signal generator clutch is tripped as previously described.

(c) As the perforator trip lever rotates counterclockwise, the reset bail trip lever linked to it (figure 2-18) pulls down an extension on the punch slide reset bail at E. The reset bail moves down, permitting the selected punch slides (figure 2-17) to move to the left under action of their bias springs.

(d) As the clutch trip bar nears the end of its stroke to the right, the upper portion of the latch comes in contact with the stop at point D. The latch then pivots counterclockwise, releasing the clutch trip bar link which moves rapidly to the left under the action of the compression spring shown immediately below the stop. The clutch trip bar link is stopped in its movement to the left by its extension striking the stop at point C. The perforator trip lever latch is to the left of and completely free of the perforator trip lever. As the clutch release pivots clockwise under the resulting action of the pin on the reset cam, the perforator trip lever

is released from its counterclockwise position and allowed to rotate clockwise to its normal position as shown in figure 2-18.

(e) In the meantime, the clutch trip bar (figure 2-18) is being reset and is moving to the left. As the latch moves to the left away from the stop at point D, it pivots clockwise to its normal position so that when the clutch trip bar is at the extreme left of its reset travel the latch is again allowed to hook under the clutch trip bar link. This completes the operating cycle.

d. OPERATION IN T POSITION. - In this position, tape is perforated by the perforator but no signals are generated by the keyboard. The keyboard is reset by the perforator since the signal generator mechanism is inoperative. This mode of operation is set up by turning the keyboard control knob to the T position. This conditions the keyboard-perforator linkage as follows:

(1) When the keyboard control knob is turned to the T position, the keyboard control selection lever (figure 2-19) is pivoted clockwise so that its pin at point B is in position to engage the hook of the reset cam follower reset lever. The right end of the keyboard control selection lever at point C falls so that it will not engage the signal generator clutch trip lever. In the T position, therefore, the signal generator clutch is not tripped and the signal generator is inoperative.

(2) The keyboard perforator linkage and perforator clutch trip system operate as described in paragraph c. above. The character counter is operative and controls the end-of-line indicator light as described in paragraph 2. L.

(3) Code bar reset is effected by the reset cam follower mechanism. When a code keylever on the keyboard is depressed, the code bar bail and clutch trip bar (figure 2-19) fall to the right so that the reset lever with hook is in position to engage the pin of the keyboard control selection lever at point B. When the perforator clutch is tripped, the reset cam begins to rotate counterclockwise and, as it does, the reset cam follower arm and associated reset lever rotate clockwise. The hook on the reset lever engages the pin on the keyboard control selection lever and moves the selection lever and clutch trip bar to the left. The configuration of the reset cam is such that, at a later stage of the operating cycle, the reset lever with hook moves away from the pin of the keyboard control selection lever. The clutch trip bar again starts to move to the right. However, the code bar bail latch latches the

code bar bail at this point, preventing further movement of the clutch trip bar as the reset cam follower arm returns to its initial position.

4. PERFORATOR MECHANISM

a. GENERAL. - The main shaft of the perforator is continuously rotated by external power applied to the main shaft gear through a driving shaft and gearing of the rear bearing bracket (figure 1-2). The rotary motion is transferred from the main shaft to the function cam by means of the perforator clutch.

b. PUNCH MECHANISM. (See figure 2-20)

(1) The punch mechanism is operated by the rockerbail through the perforator drive link. The rocker bail receives its motion from the function cam through two rocker bail cam follower rollers. The rollers are positioned relative to two lobes of the cam in such a way that one roller provides power for tape perforating and the other provides power for the tape feeding.

(2) The perforator drive link connects the rocker bail to the rocker arm. The rocker arm, in turn, is connected through a toggle bail to operate the punch main bail and reset bail. When the punch slides are selected, they fall under spring tensions to their operated position. A hook on the punch slide engages a post on the main bail so that the punch slides move with the main bail during the perforating cycle. The main bail then drives the selected punch slides upward to operate the punch pins.

(3) During the tape feeding half of the perforating cycle, the punch slides are driven to their unoperated positions by the reset bail.

(4) The tape feeding function is accomplished by the perforator feed pawl (figure 2-21) which is attached to the toggle bail. The feed pawl drives the feed wheel to its detented position during the tape feeding cycle.

(5) Feed holes are rolled into the tape for ten characters per inch spacing. The tape is pressed on the feed wheel by the die wheel and is held by the tape shoe and its torsion spring. The tape is stripped from the feed wheel by a stripper plate of the punch block assembly and fed into the punch block. A tape guide spring holds the tape against a reference block, and the feed holes are maintained a constant distance from the tape edge.

(6) As the tape feeds into the punch block, it is held against the reference edge by a spring, and the relation of the code holes to the edge of

the tape is maintained constant.

(7) The retractor bail engages a notch in each punch pin to retract the pin after perforation.

(8) During the perforating operation, the notch in the selected punch pin engages the retractor bail which, under spring tension, holds the punch pins against their respective punch slides until the pins clear the lower edge of the tape and the retractor bail reaches its rest position.

(9) The retractor tension springs are connected to the main bail assembly so that when the punch slide contacts the punch pin, the slide, bail, retractor, and retractor tension spring move as a unit. A compression spring is mounted on the #3 punch pin. This arrangement makes the peak punching load approximately equal to the peak feed load. The stripper plate of the punch block assembly and the tape shoes are designed in such a way that tape feeding from the feed wheel is pressed against the stripper plate by the tape shoe, thereby eliminating the necessity of a tape shield. This facilitates printing on the tape and clearing of tape jams.

c. POWER DRIVE BACKSPACE MECHANISM. (See figures 2-21 and 2-22) - The power drive backspace mechanism is used to backspace perforated tape to delete errors in character information. The erroneously punched character is obliterated by pressing the LTRS keylever. Backspacing is accomplished automatically by pressing the TAPE B. SP. keylever (figure 2-22) on the keyboard. The detailed operation of the mechanism is as follows:

(1) When the TAPE B. SP. keylever is depressed, the switch associated with the tape backspace button assembly is closed. The circuit to the magnet assembly of the power drive backspace mechanism is then energized, causing the armature bail to fall.

(2) When the armature bail falls, an extension on the bail disengages the drive link latch, which drops and engages a notch in the eccentric arm.

(3) The eccentric arm, which is driven by the cam shaft of the perforator, moves to the right. This action causes the bell crank handle to be depressed through the system of linkages between the drive link latch and the bell crank.

(4) Depressing the handle of the bell crank causes the rake to be rotated counter-clockwise through the gearing of the rake and the segment gear. The rake teeth contact and depress the

chads of the tape.

(5) When the bell crank handle is partially depressed, it contacts an extension of the perforator feed pawl. Further movement downward causes the perforator feed pawl to be disengaged from the feed wheel ratchet.

(6) The backspacing feed pawl then engages the feed wheel ratchet and rotates the feed wheel clockwise, backspacing the tape to the next row of perforations. Backspacing is continued until the erroneously punched character (or the first of several erroneously typed characters) is above the punch pins.

(7) The LTRS keylever is then operated to obliterate the erroneously punched characters and all punched characters that follow.

(8) When the magnet assembly is de-energized upon release of the TAPE B. SP. keylever, the armature bail extension moves upward, and disengages the drive link latch from the eccentric arm. In the unoperated position, the fork of the eccentric arm slides freely along the pivot post of the drive link.

d. CODE READING CONTACT MECHANISM. (See figure 2-23) - These contacts are used to electrically read the code combinations being perforated. The code information is fed to ex-

ternal electrical circuits for end use. The mechanism consists of a bank of five make-type contacts mounted adjacent to the perforator punch slides. Each contact is actuated by its associated punch slide. In the perforator stop position, each code reading contact is held open by engagement with an insulator on its associated punch slide. When the selected punch slides move toward the punch block during the selection cycle, the associated contacts close. The resulting electrical output consists of spacing and marking pulses corresponding to the code combinations being perforated.

e. AUXILIARY TIMING CONTACT MECHANISM. (See figure 2-24) - This contact provides electrical pulses which are synchronized with the code reading contact pulses for circuitry control purposes. The mechanism consists essentially of a signal contact pile-up of the break-before-make type and a contact bail and cam follower arm. The mechanism is mounted to the frame of the perforator so that the cam follower arm is actuated by the perforator function cam. In the stop position, the contacts, bail and cam follower arm are positioned as shown in figure 2-24. When the cam rotates, the cam follower falls and the contact bail engages the swinger insulator to close the contacts at the left. On the second half of the cam cycle, the cam engages the cam follower roller and restores the contacts to their normal stop position.

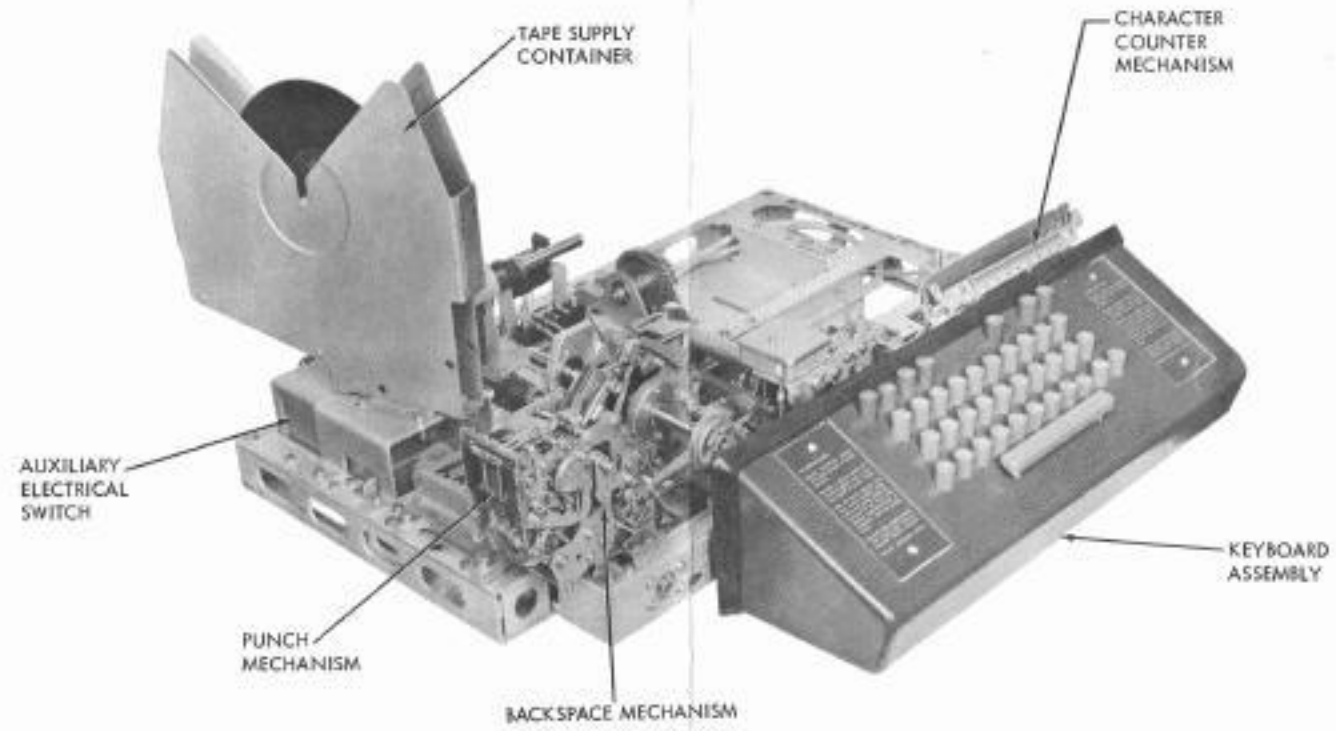

FIGURE 1-1 MODEL 20 PERFORATOR TRANSMITTER BASE, LEFT FRONT VIEW

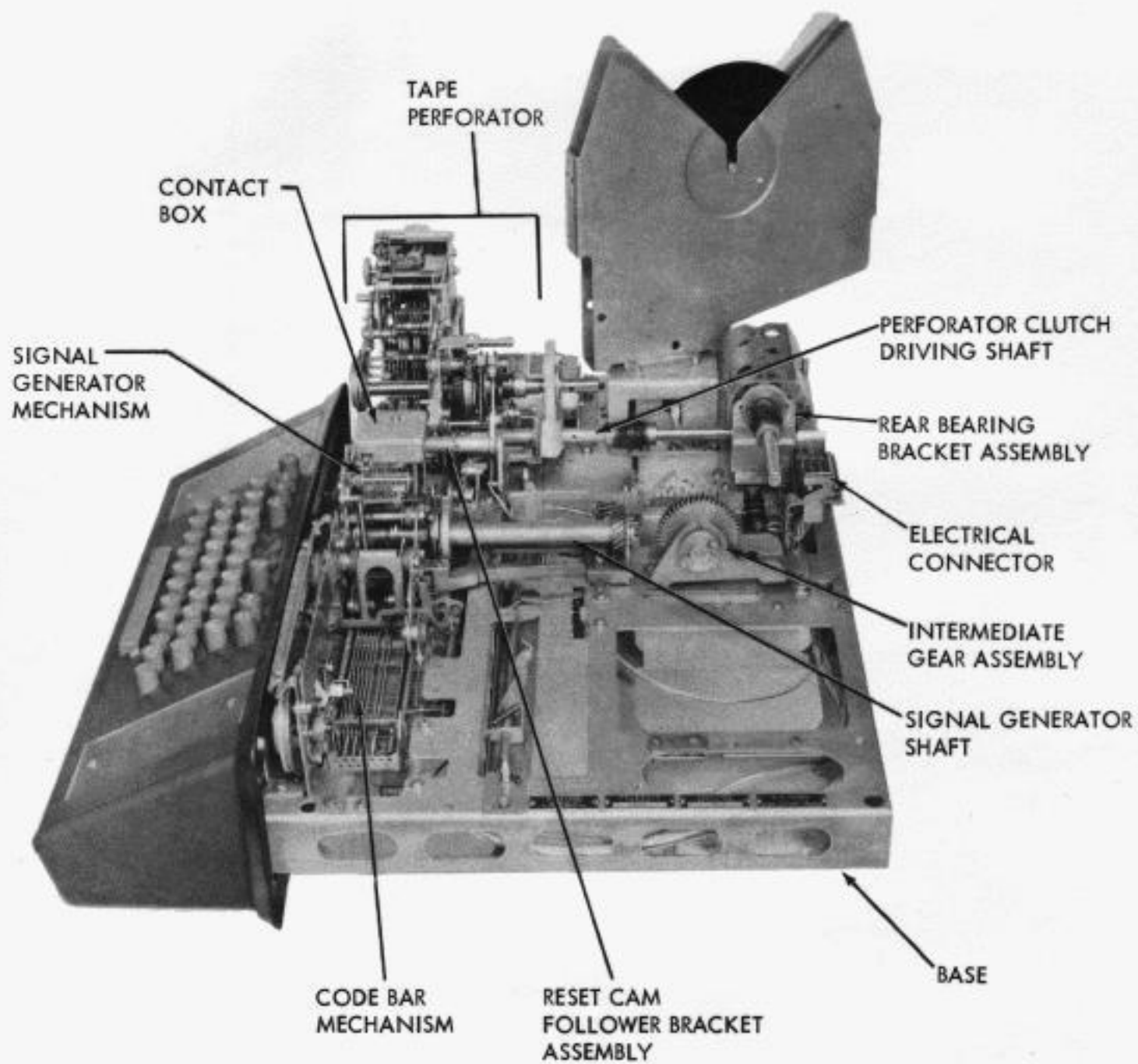

FIGURE 1-2 MODEL 28 PERFORATOR TRANSMITTER BASE, RIGHT SIDE VIEW

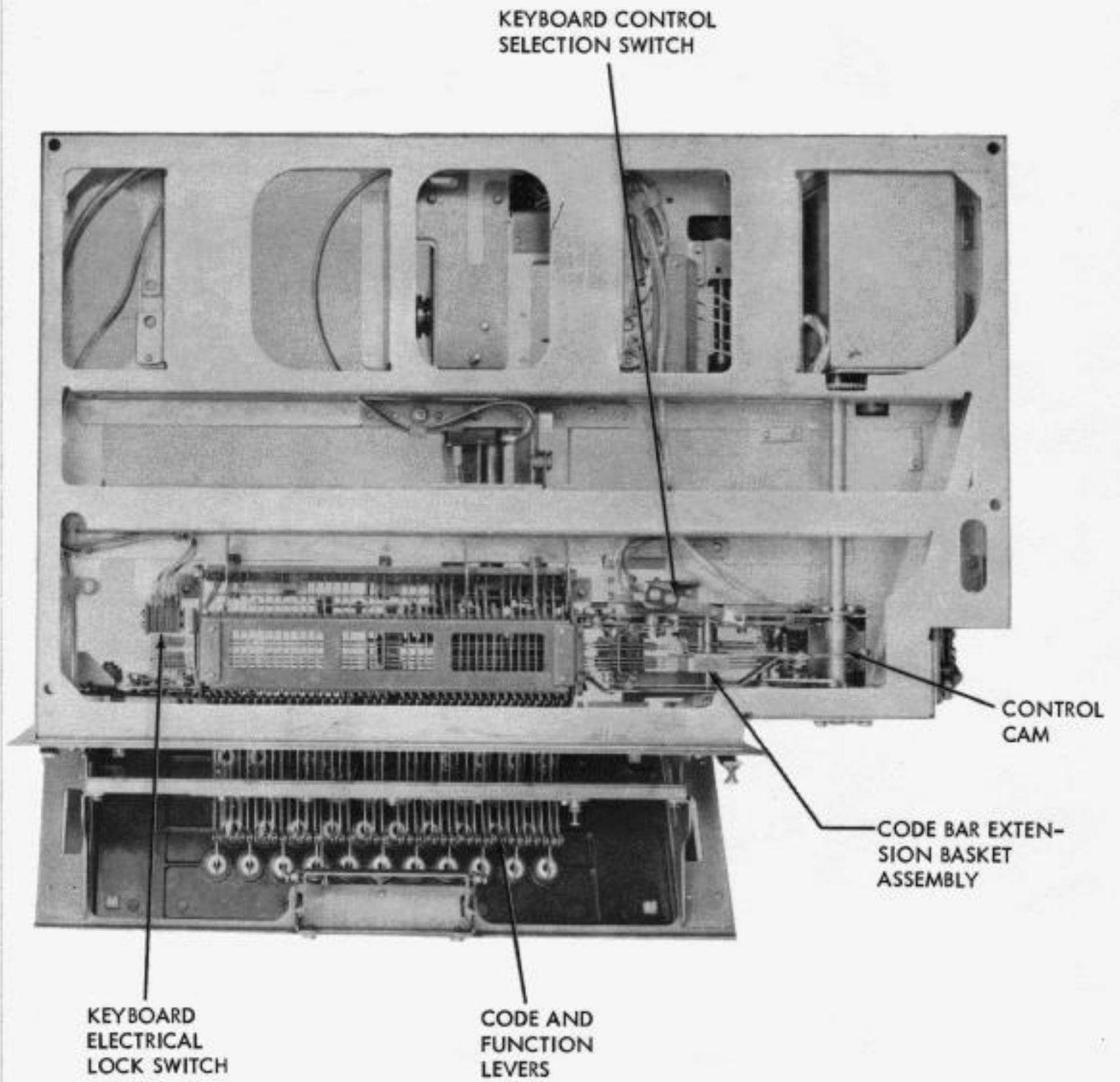

FIGURE 1-3 MODEL 28 PERFORATOR TRANSMITTER BASE, BOTTOM VIEW

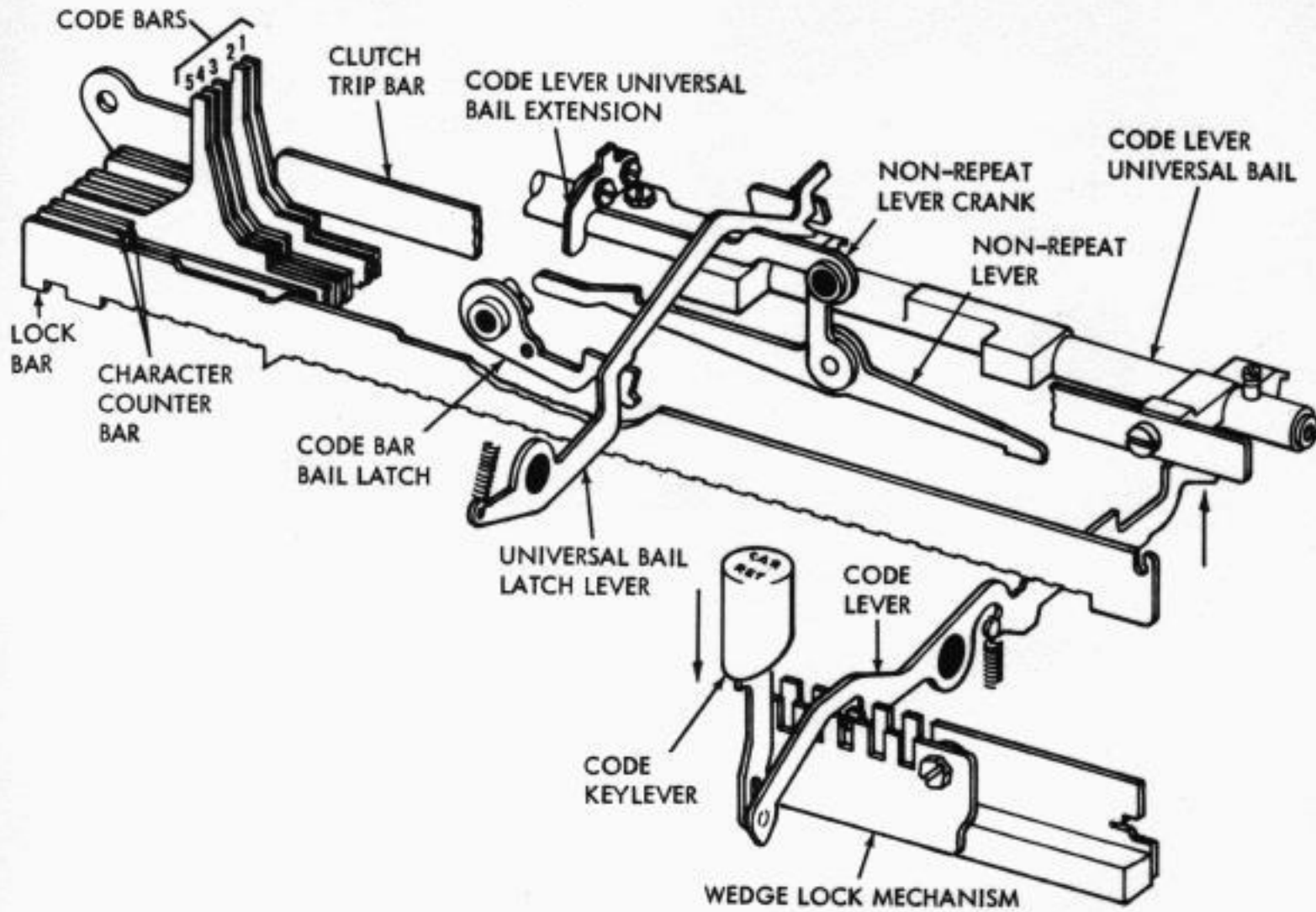

FIGURE 2-1 CODE BAR & CODE LEVER UNIVERSAL BAIL MECHANISM

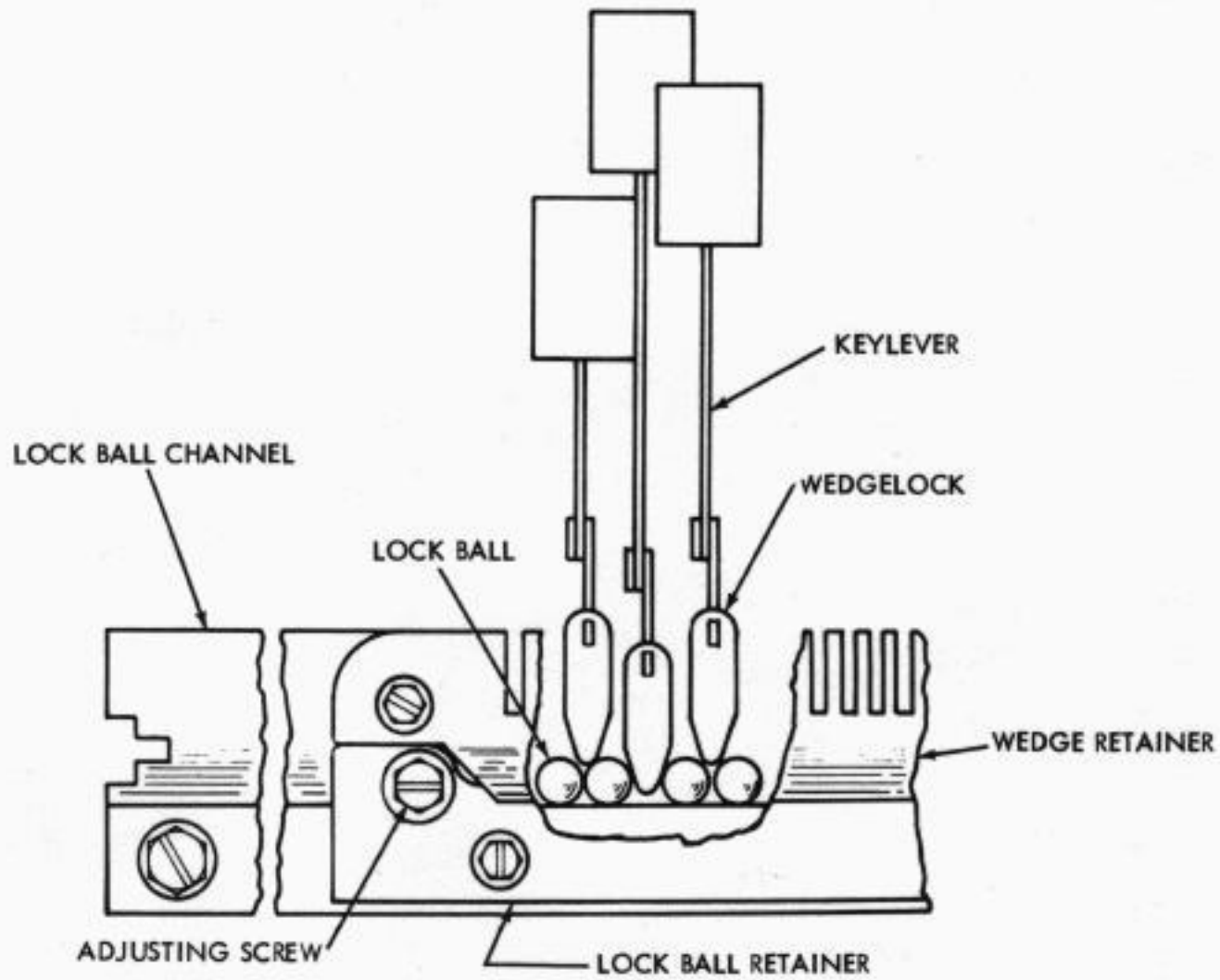

FIGURE 2-2 WEDGELOCK MECHANISM

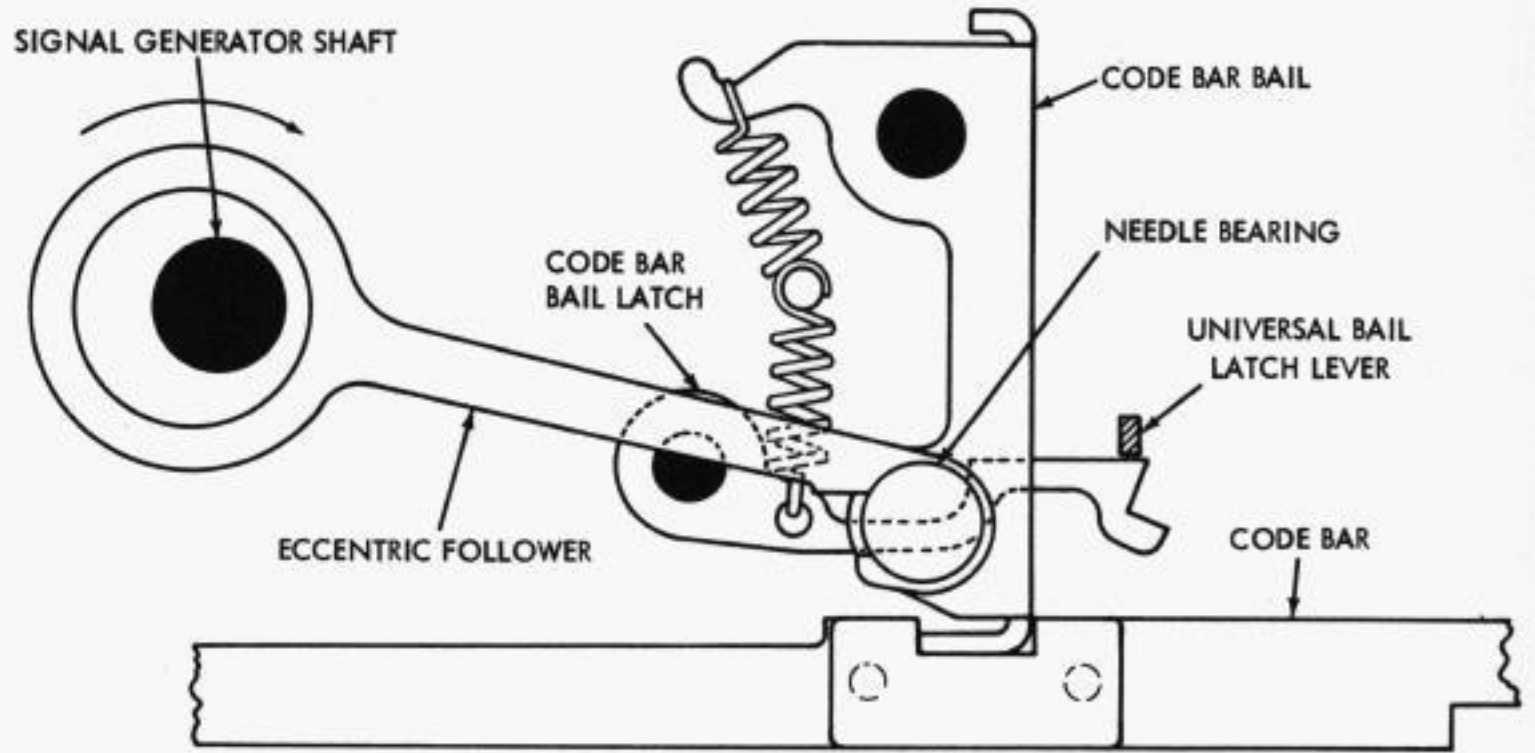

FIGURE 2-3 CODE BAR BAIL MECHANISM

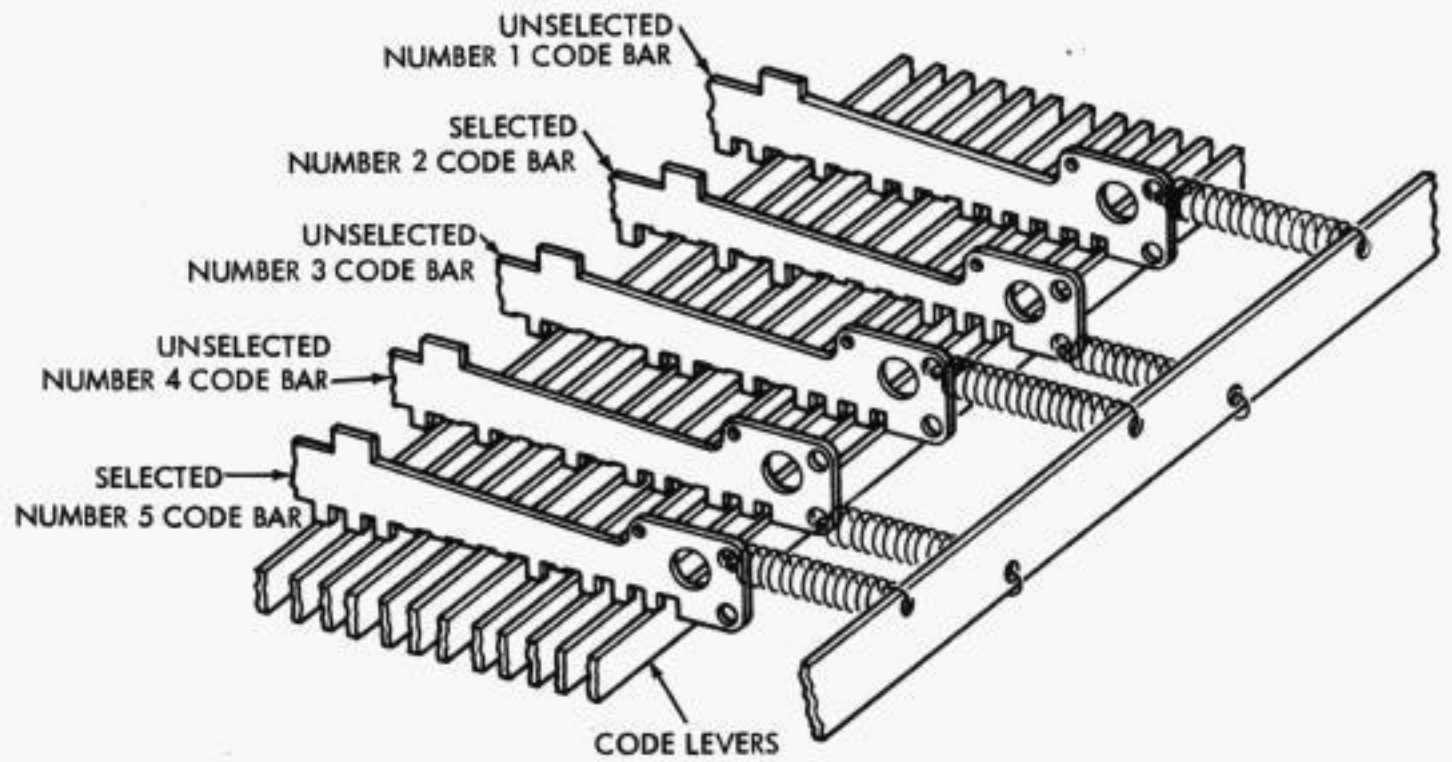

FIGURE 2-4 CODE BAR SELECTION

FIGURES 2-1, 2-2,
2-3, 2-4

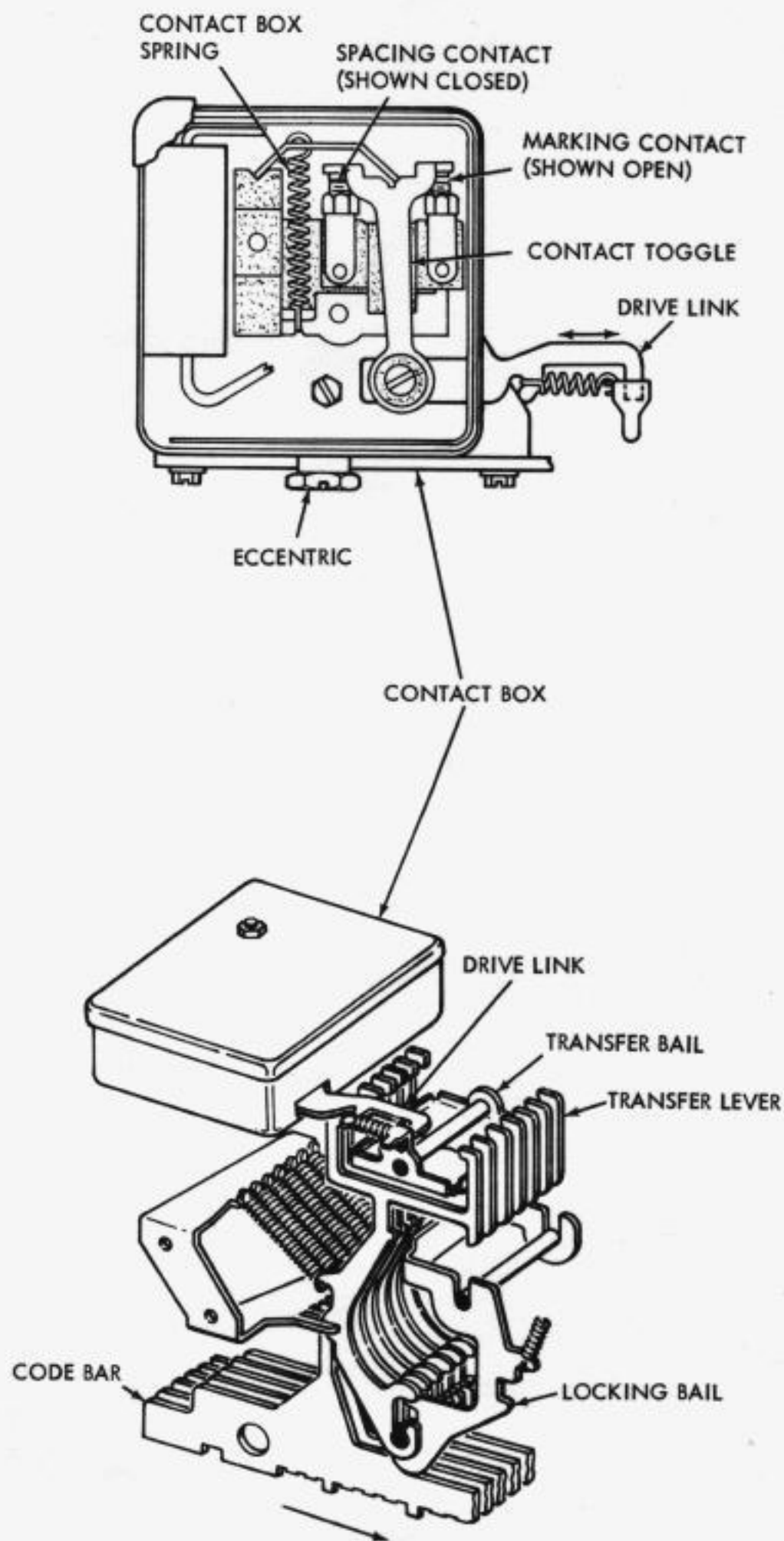

FIGURE 2-5 TRANSFER LEVER MECHANISM & CONTACT BOX MECHANISM

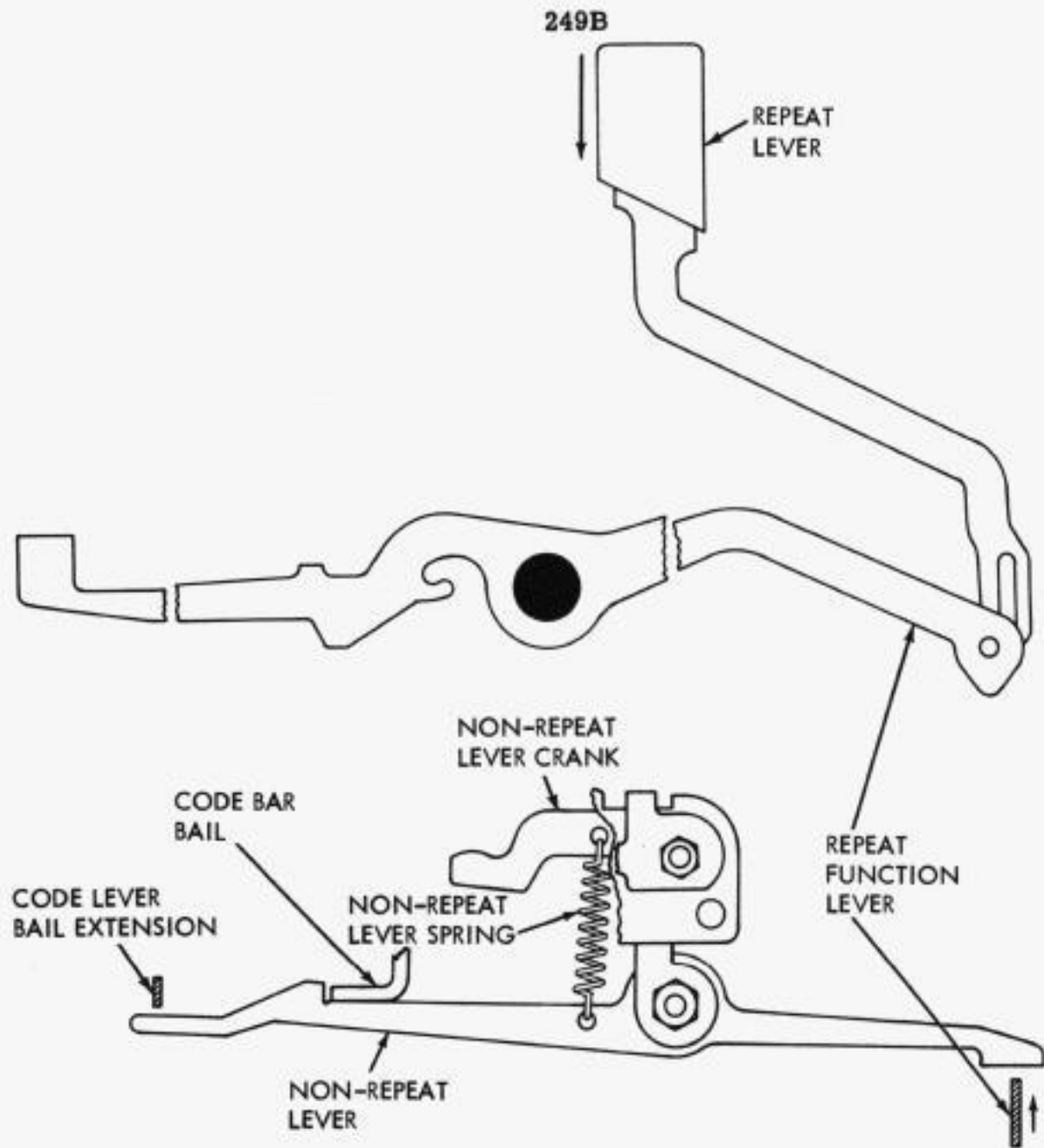

FIGURE 2-6 REPEAT MECHANISM

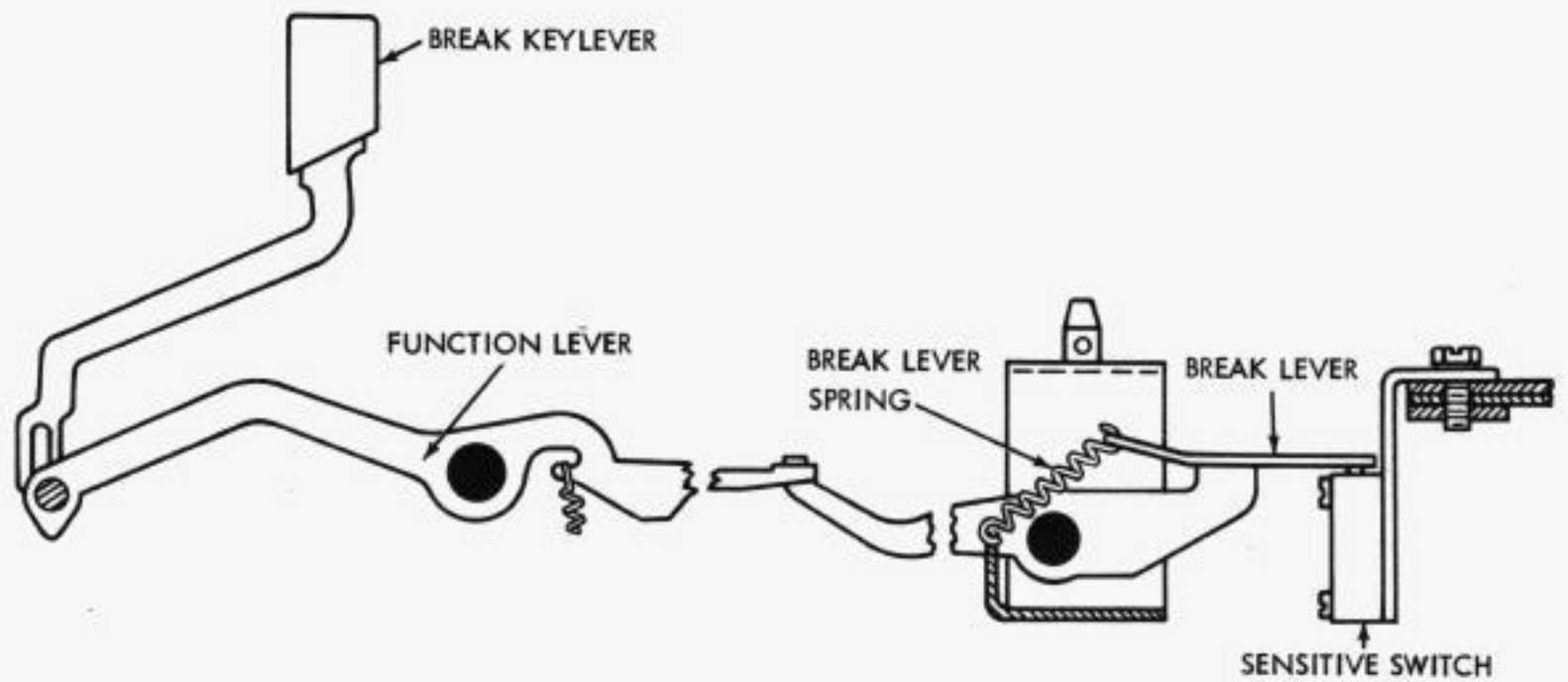

FIGURE 2-7 ELECTRICAL LINE BREAK MECHANISM

FIGURES 2-5, 2-6,
2-7

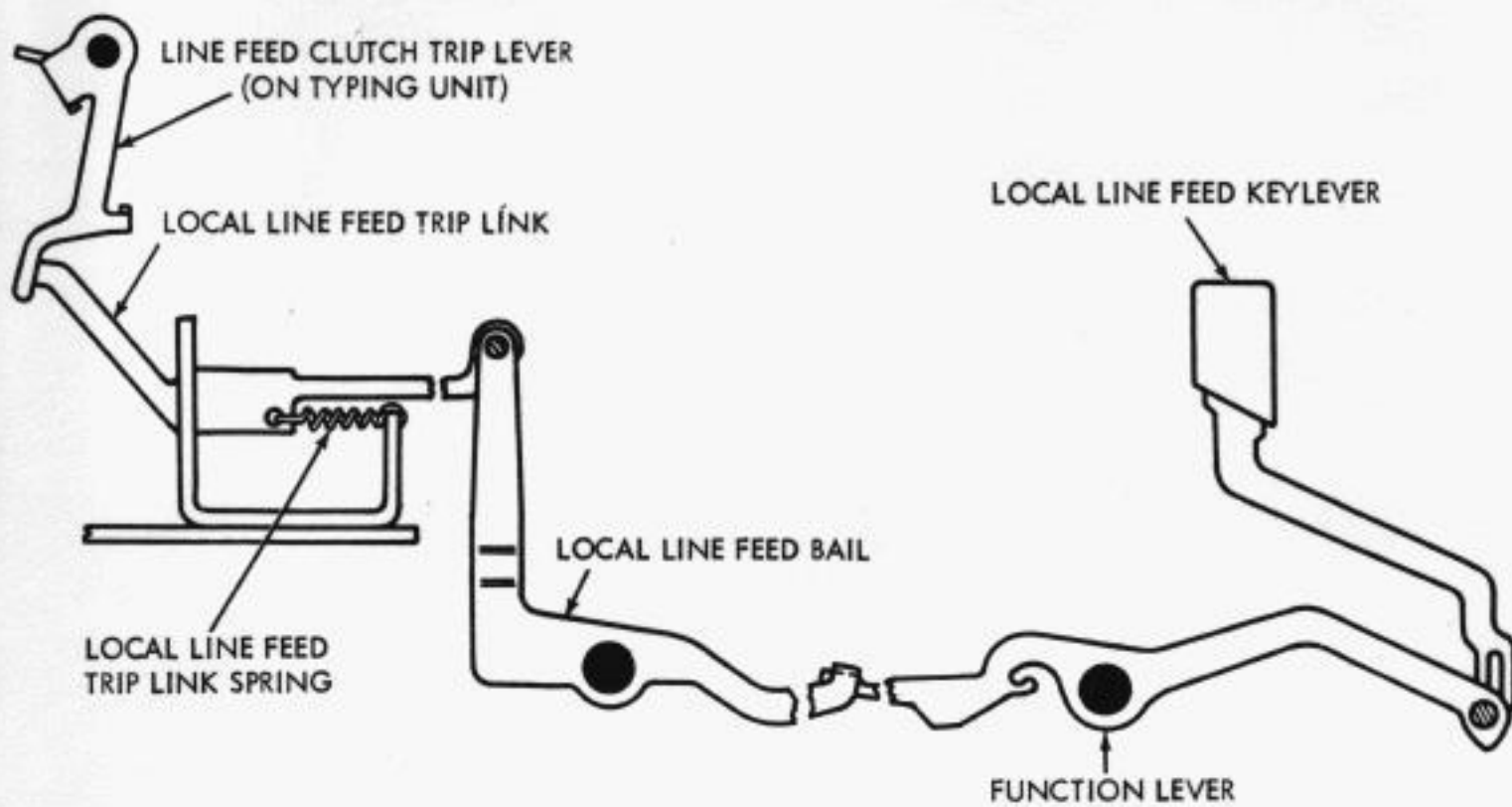

FIGURE 2-8 LOCAL LINE FEED MECHANISM

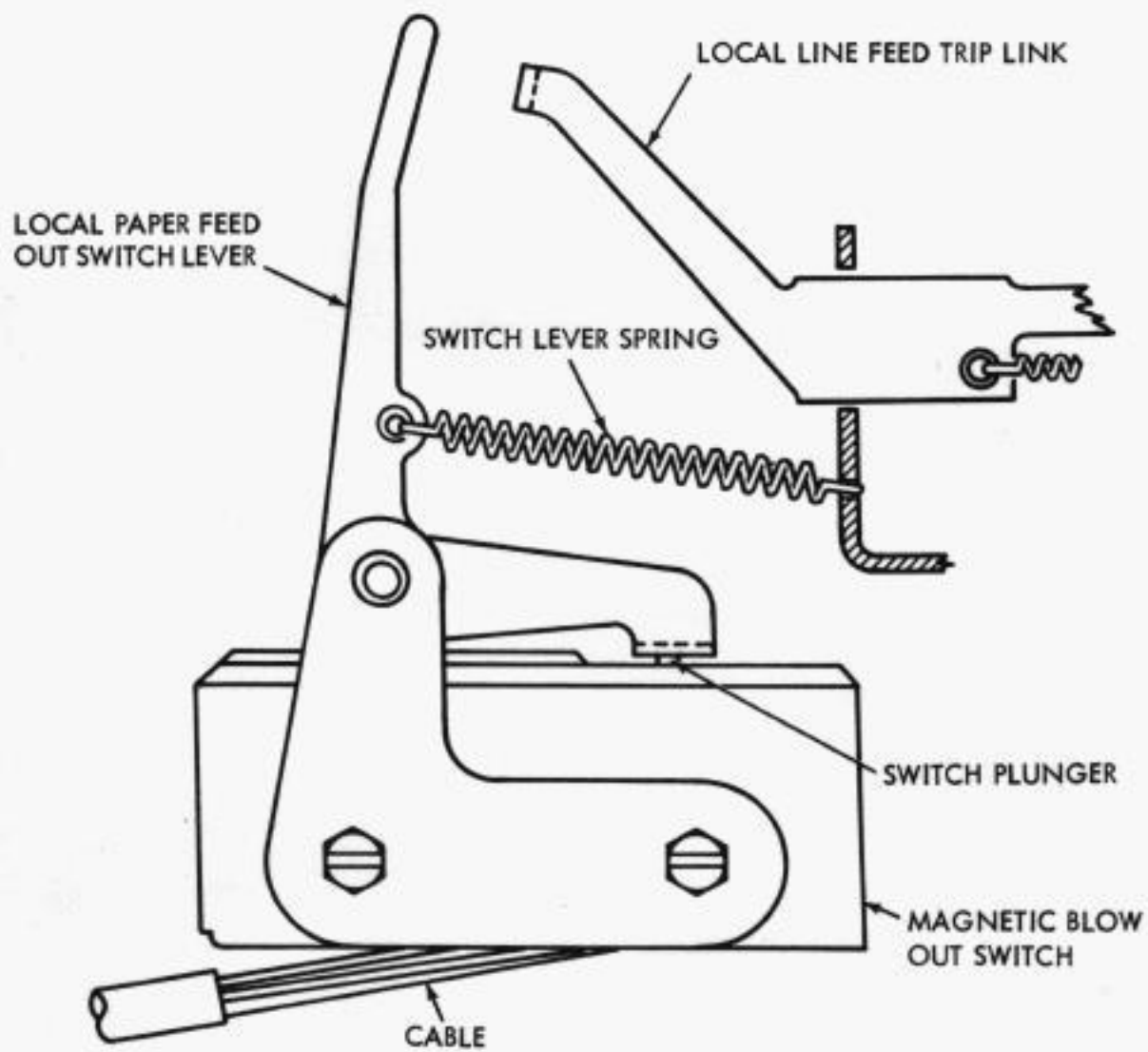

FIGURE 2-9 LOCAL PAPER FEED OUT MECHANISM

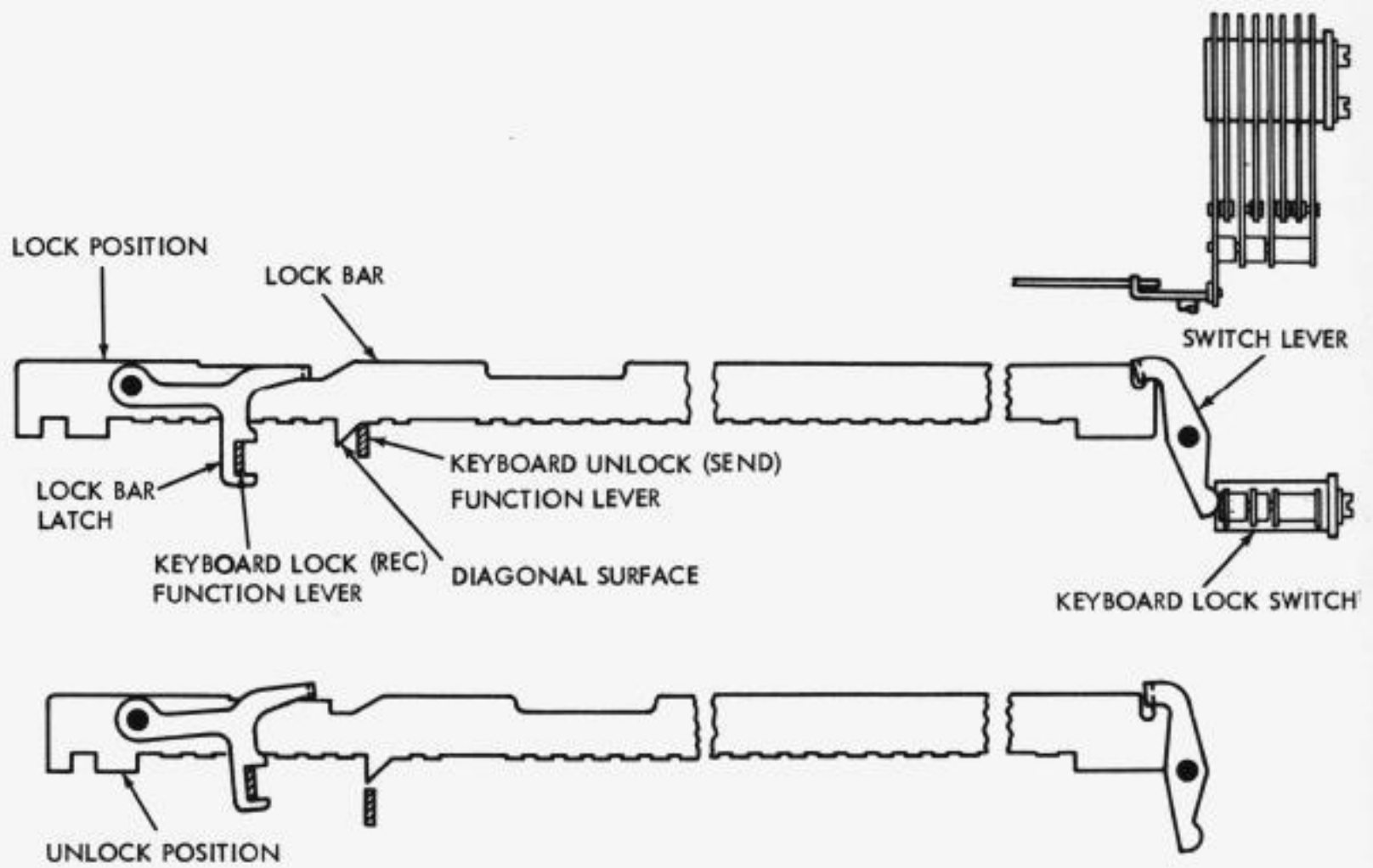
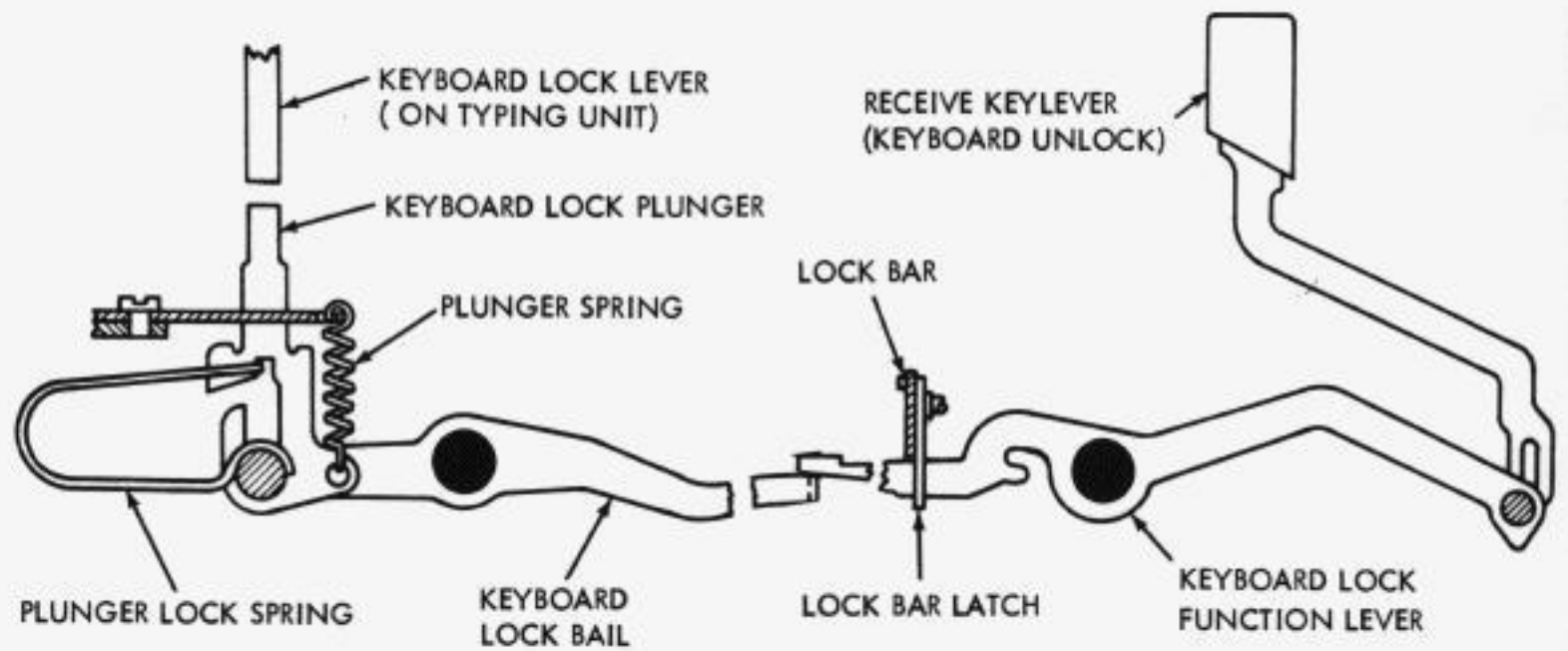

FIGURE 2-10 ELECTRICAL KEYBOARD LOCK MECHANISM

FIGURES 2-8, 2-9,
2-10

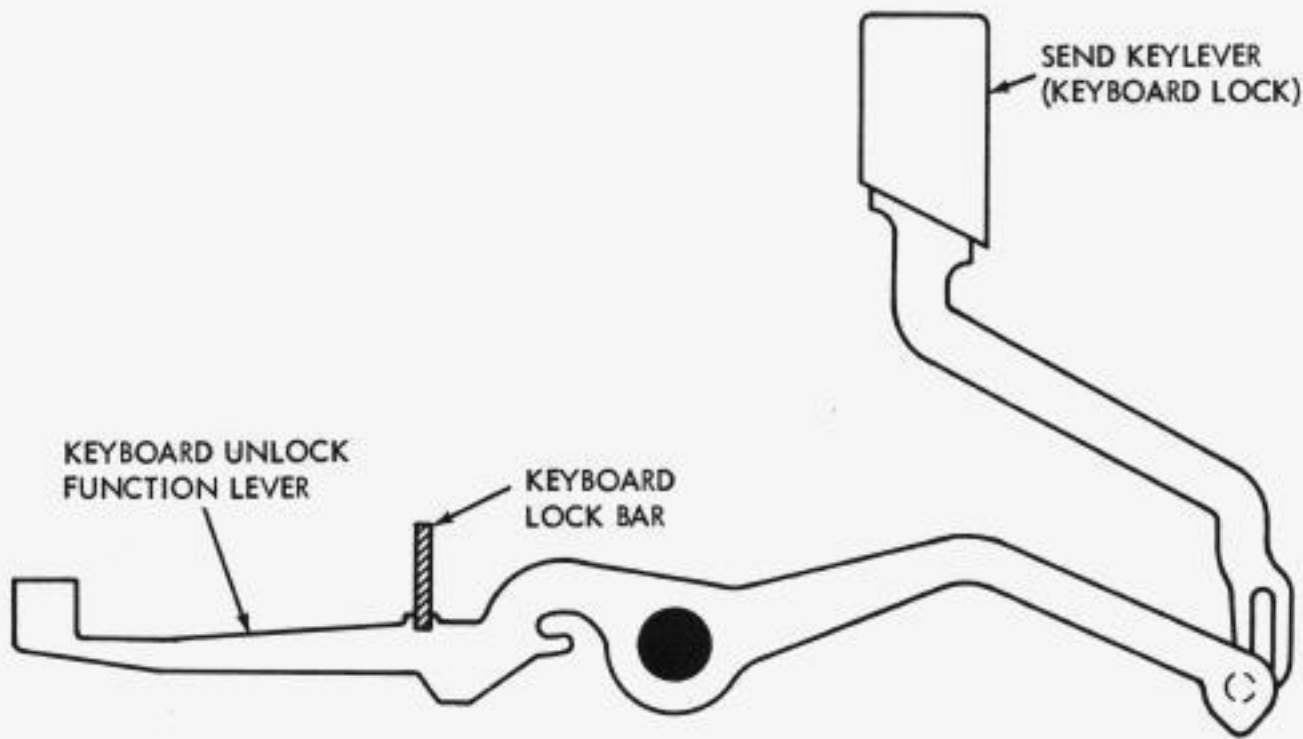

FIGURE 2-11 KEYBOARD UNLOCK MECHANISM

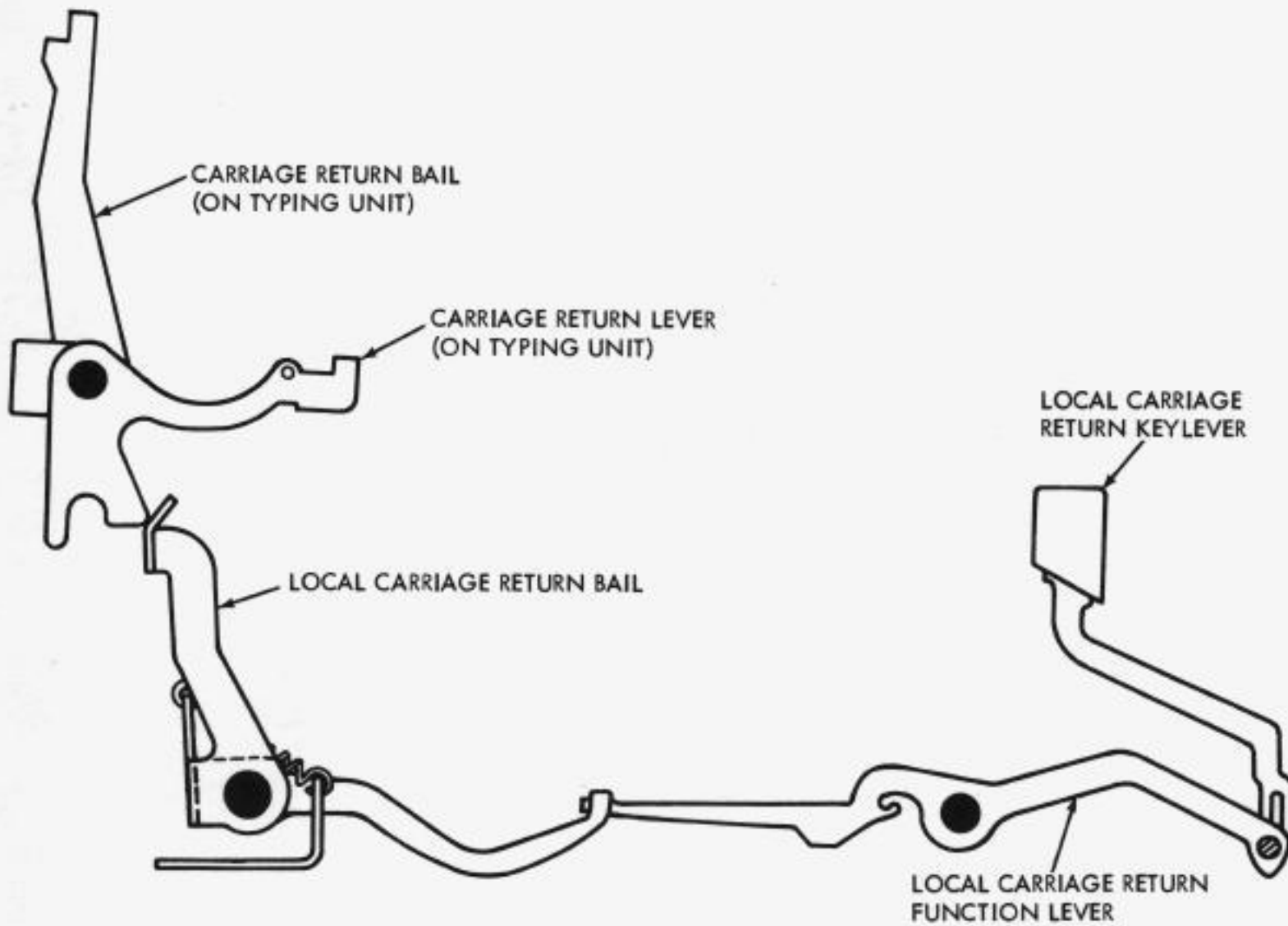

FIGURE 2-12 LOCAL CARRIAGE RETURN MECHANISM

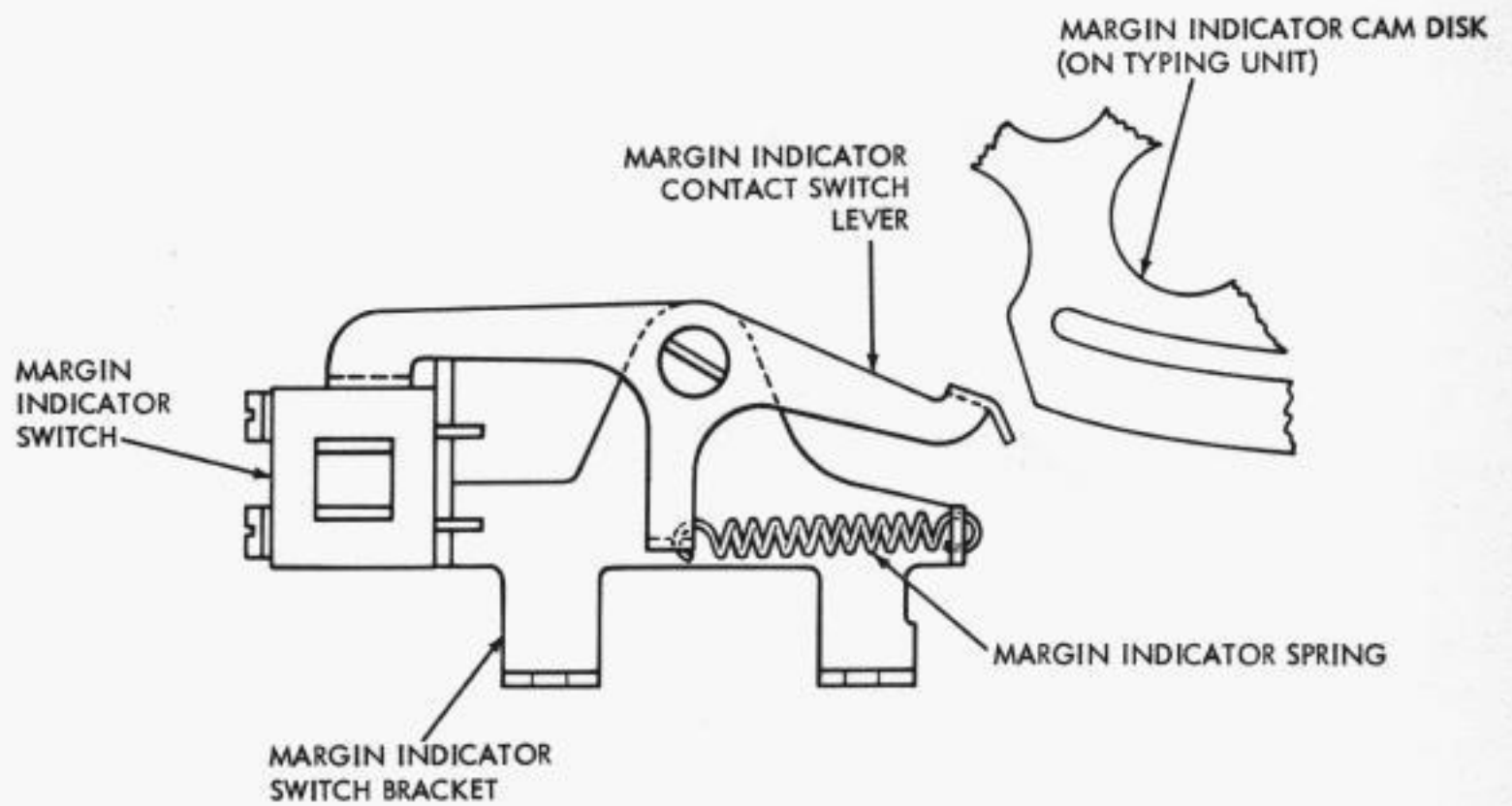

FIGURE 2-13 MARGIN INDICATOR MECHANISM

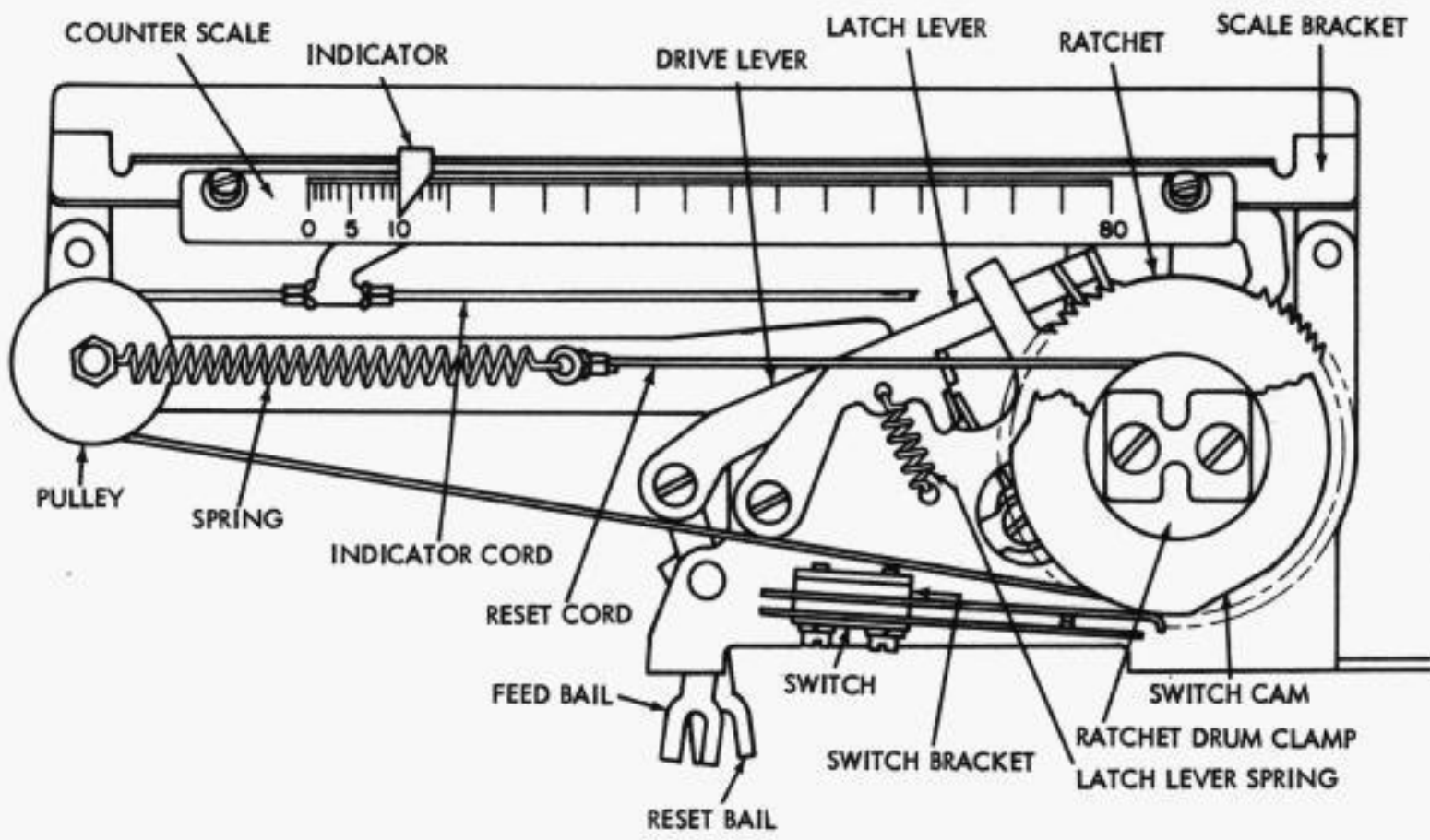

FIGURE 2-14 CHARACTER COUNTER MECHANISM FRONT VIEW

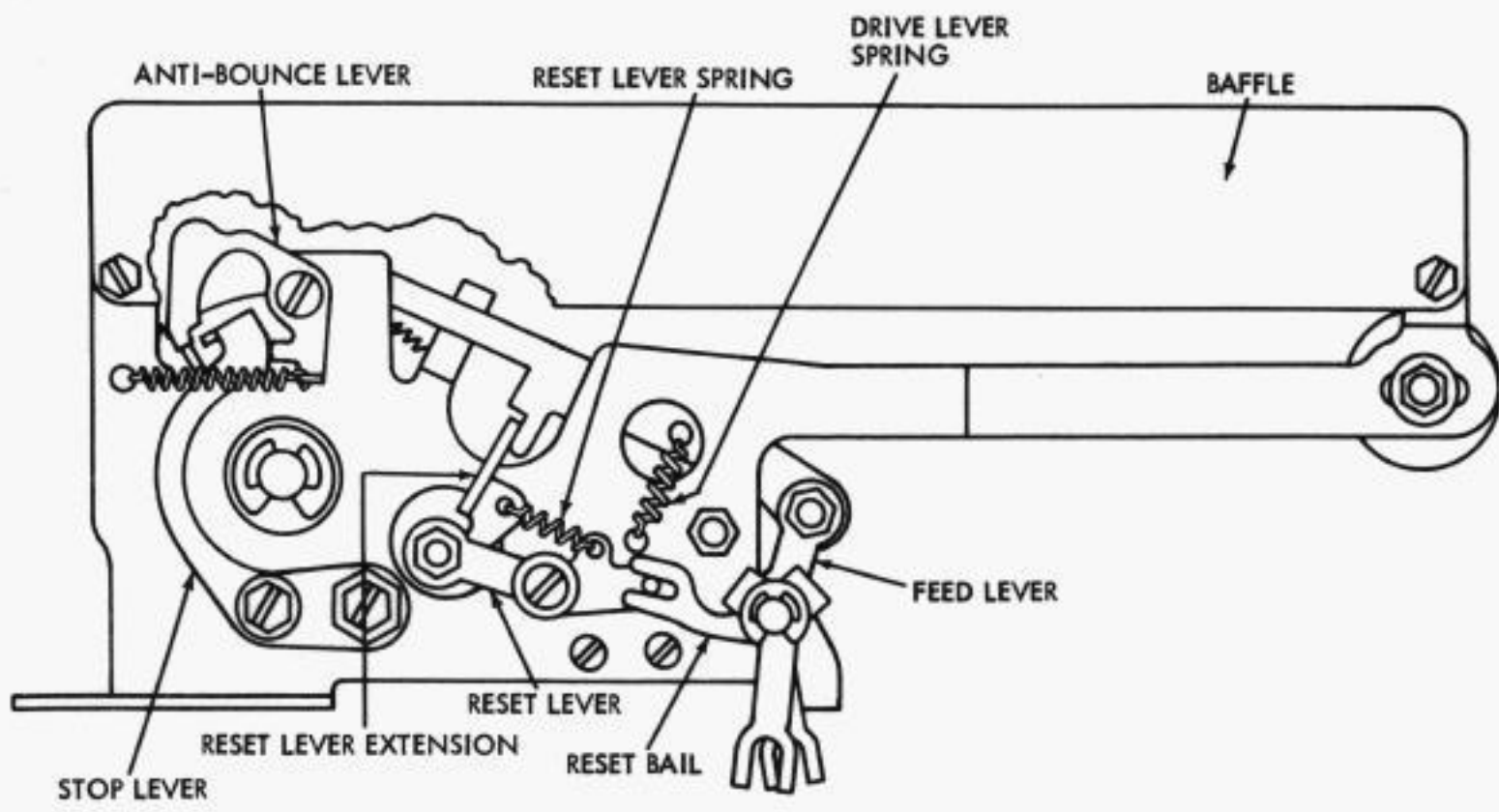

FIGURE 2-15 CHARACTER COUNTER MECHANISM, REAR VIEW

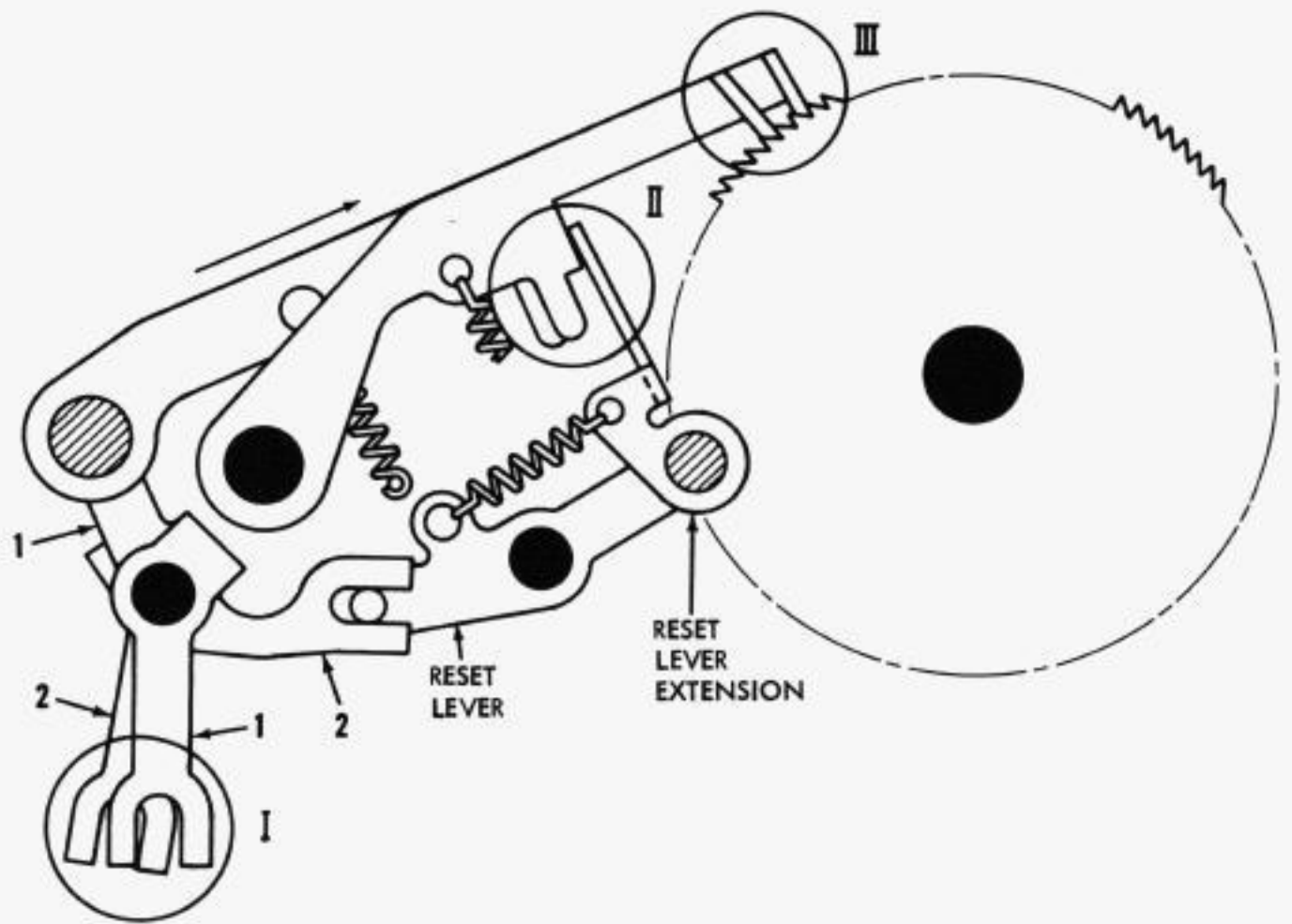
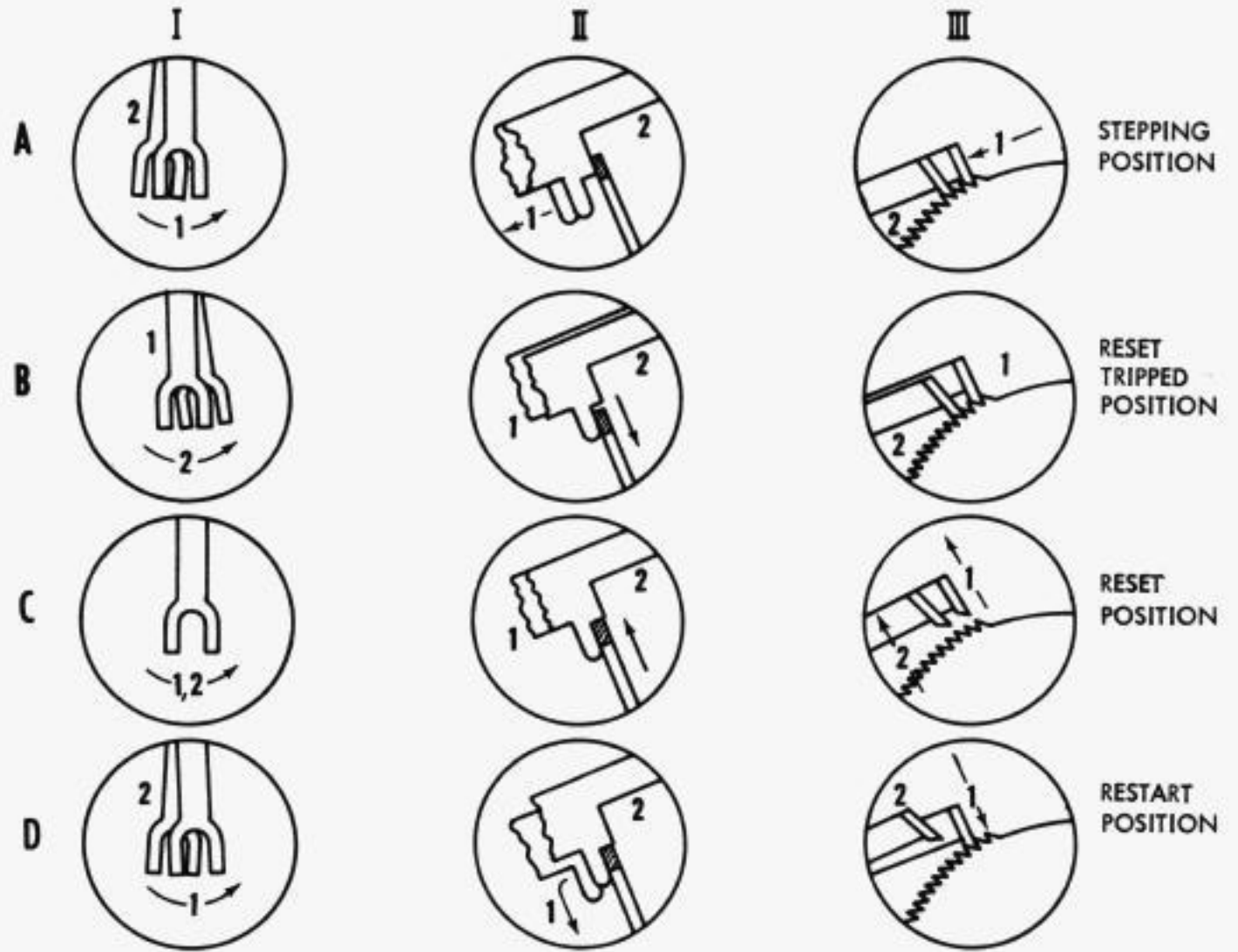

FIGURE 2-16 OPERATION OF CHARACTER COUNTER MECHANISM

FIGURES 2-14, 2-15,
2-16

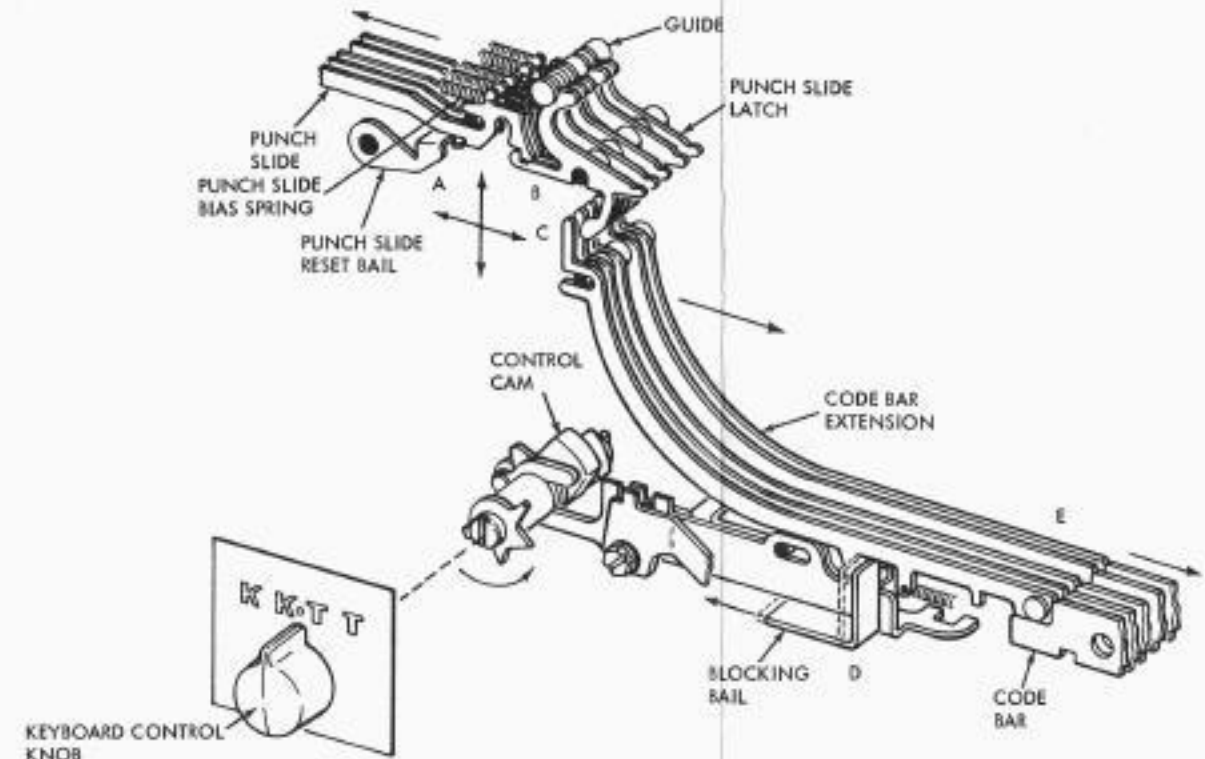

FIGURE 2-17 KEYBOARD-PERFORATOR LINKAGE, VIEW 1

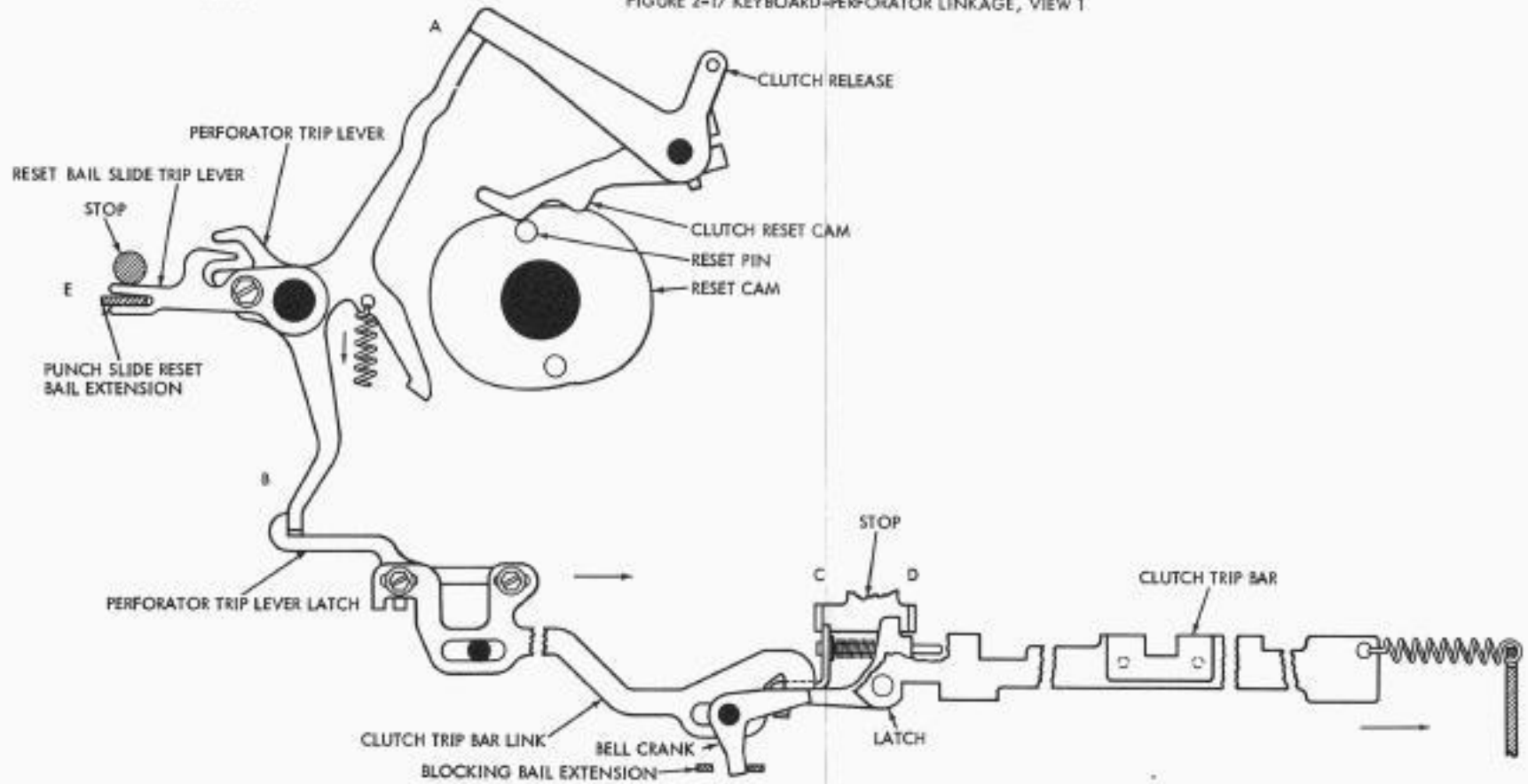

FIGURE 2-18 KEYBOARD - PERFORATOR LINKAGE, VIEW 2

ORIGINAL

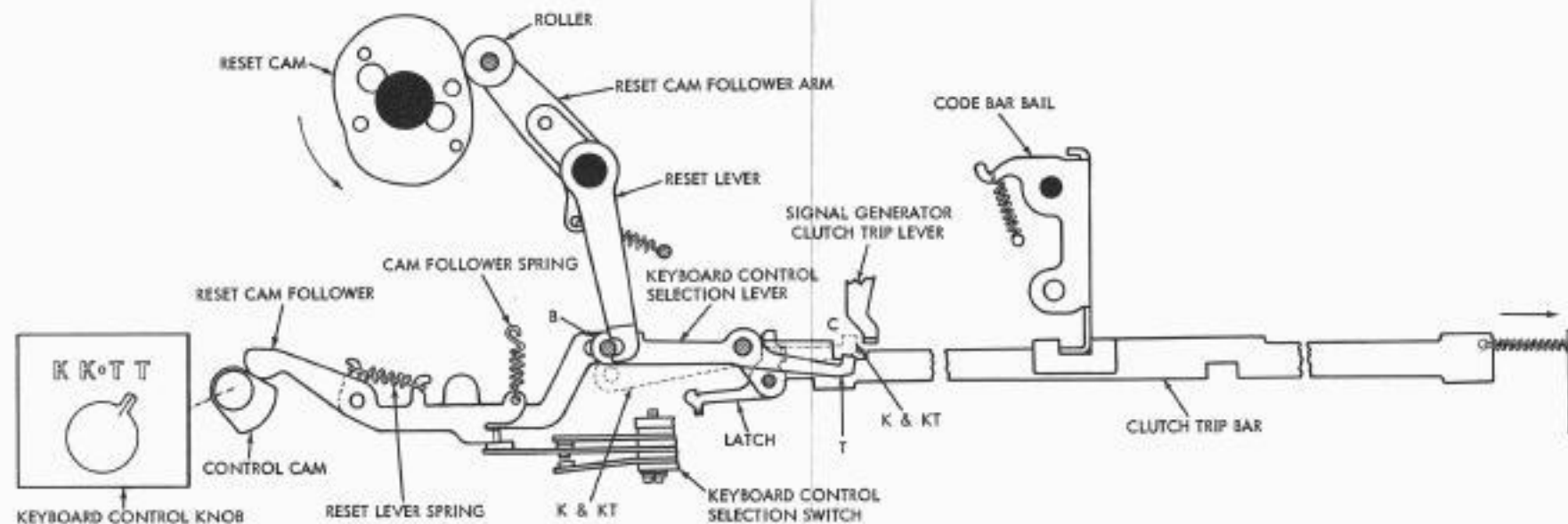

FIGURE 2-19 KEYBOARD - PERFORATOR LINKAGE, VIEW 3

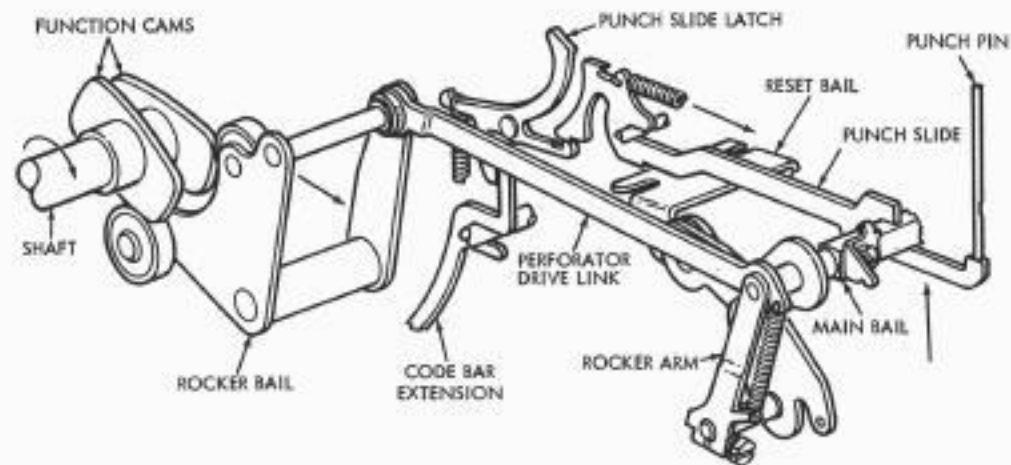

FIGURE 2-20 PERFORATOR PUNCH MECHANISM

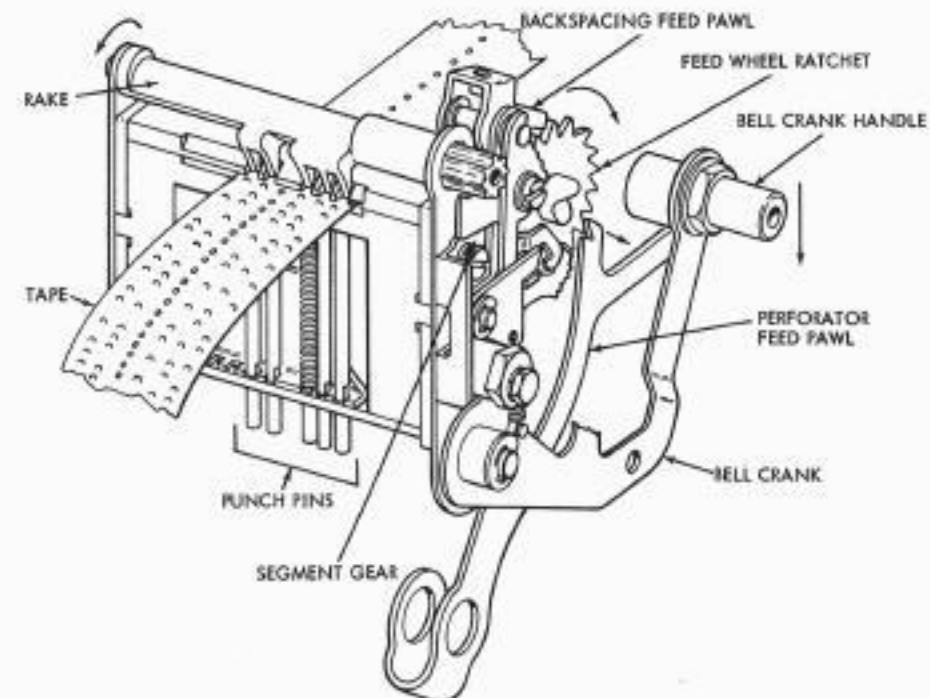

FIGURE 2-21 POWER DRIVE BACKSPACE MECHANISM, VIEW 1

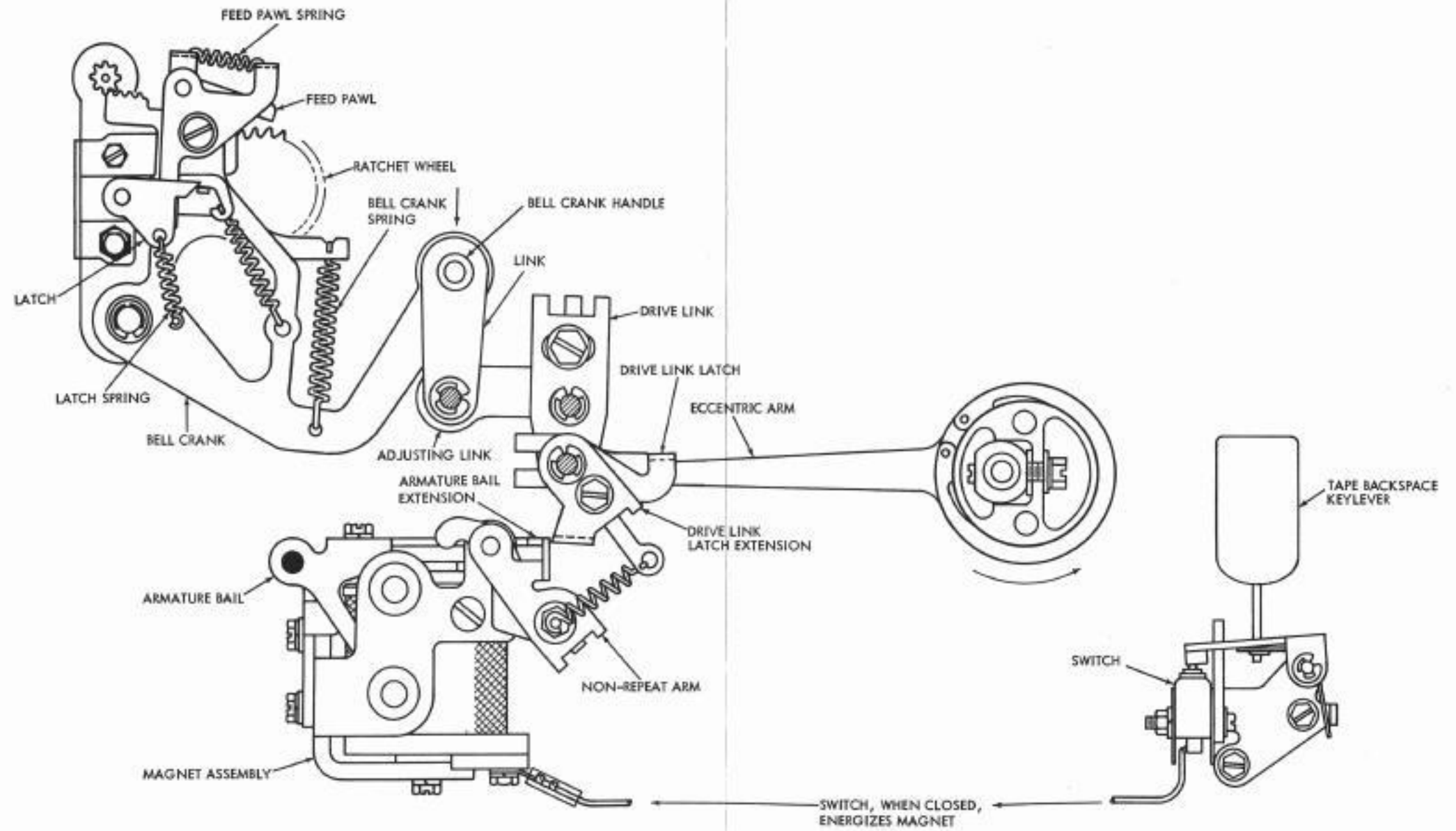

FIGURE 2-22 POWER DRIVE BACKSPACE MECHANISM VIEW 2

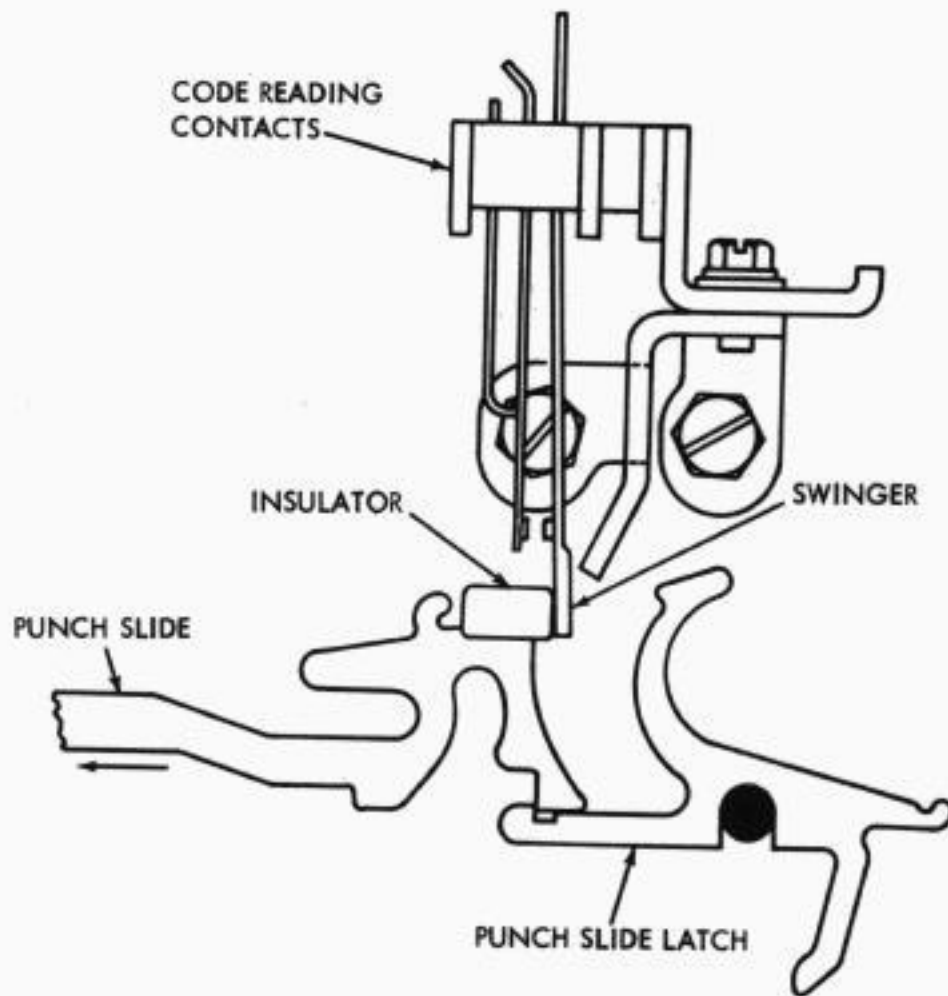

FIGURE 2-23 CODE READING CONTACT MECHANISM

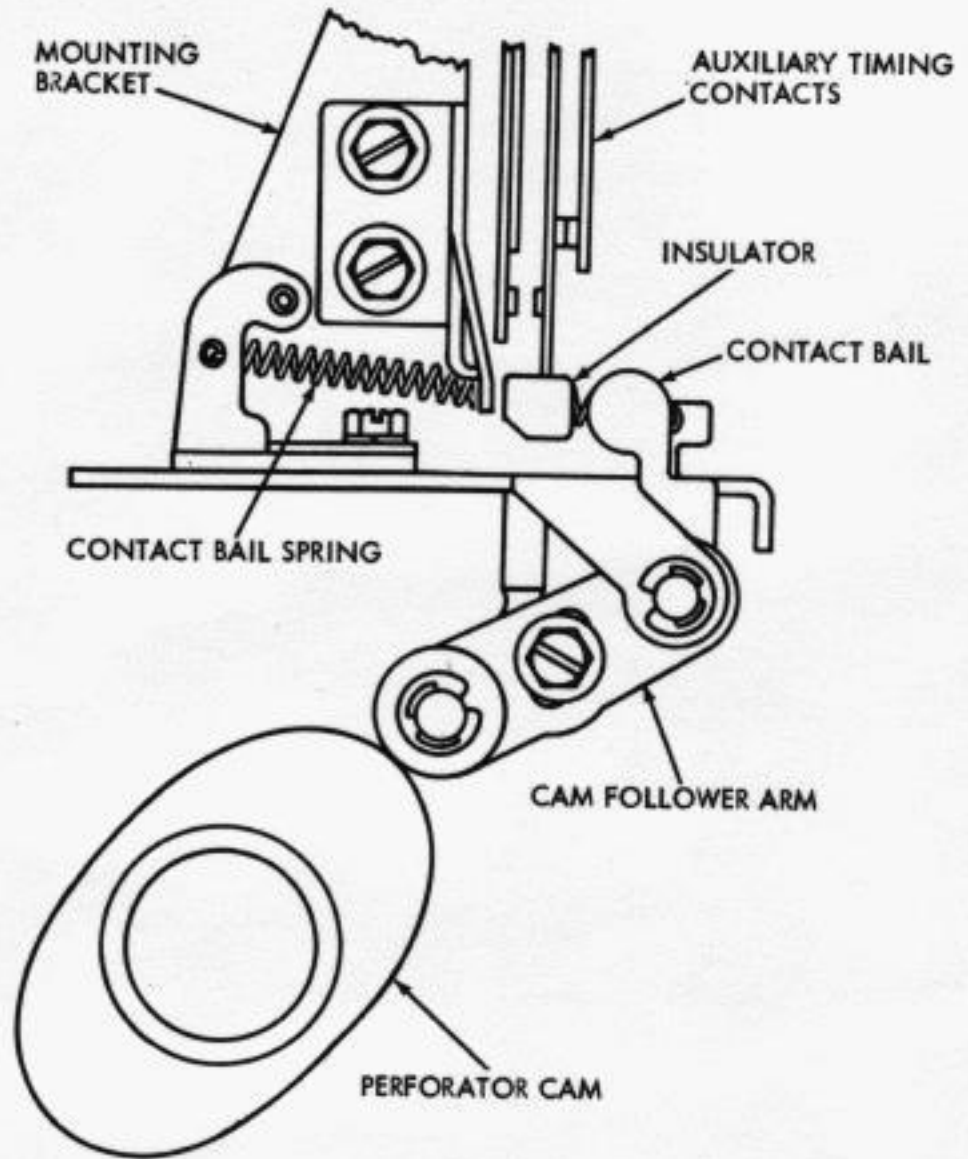

FIGURE 2-24 AUXILIARY TIMING CONTACT MECHANISM