



BULLETIN 243B

ADJUSTMENTS AND LUBRICATION
MODEL 28

TRANSMITTER DISTRIBUTOR - LBXD
BASES - LBXB, LCXB, LMXB
CABINETS - AC, LBAC

TELETYPE[®]
CORPORATION
SUBSIDIARY OF *Western Electric Company* INC.

SKOKIE, ILLINOIS, U.S.A.



BULLETIN 243B

ADJUSTMENTS AND LUBRICATION
MODEL 28

TRANSMITTER DISTRIBUTOR - LBXD
BASES - LBXB, LCXB, LMXB
CABINETS - AC, LBAC

TELETYPE[®]
CORPORATION
SUBSIDIARY OF *Western Electric Company* INC.

SKOKIE, ILLINOIS, U.S.A.

COPYRIGHT 1957 BY TELETYPE CORPORATION IN UNITED STATES. COPYRIGHT
IN ALL COUNTRIES PARTICIPATING IN INTERNATIONAL CONVENTION AND PAN
AMERICAN CONVENTIONS. ALL RIGHTS RESERVED INCLUDING RIGHTS OF TRANS-
LATION INTO ALL LANGUAGES.

Printed in U.S.A.

LIST OF EFFECTIVE PAGES

MAY, 1963

(Supersedes Issue of June, 1962)

Page Number	Change In Effect
A to F	Change 4
1-1 to 1-4	Change 4
1-5, 1-6	Change 5
1-7 to 1-12	Change 4
1-13, 1-14	Change 5
1-15 to 1-17	Change 4
1-18	Change 5
1-19 to 1-23	Change 4
1-24	Change 5
1-25 to 1-46	Change 4
1-47 to 1-51	Change 5
1-52, 1-53	Change 4
1-54, 1-55	Change 5
2-1 to 2-4	Change 4
3-1 to 3-13	Change 4
3-14	Change 5
3-15 to 3-17	Change 4
4-0 to 4-7	Change 4

The above list indicates the effective pages as of the date of issue. Upon receipt of change pages, insert them numerically and discard any superseded pages.

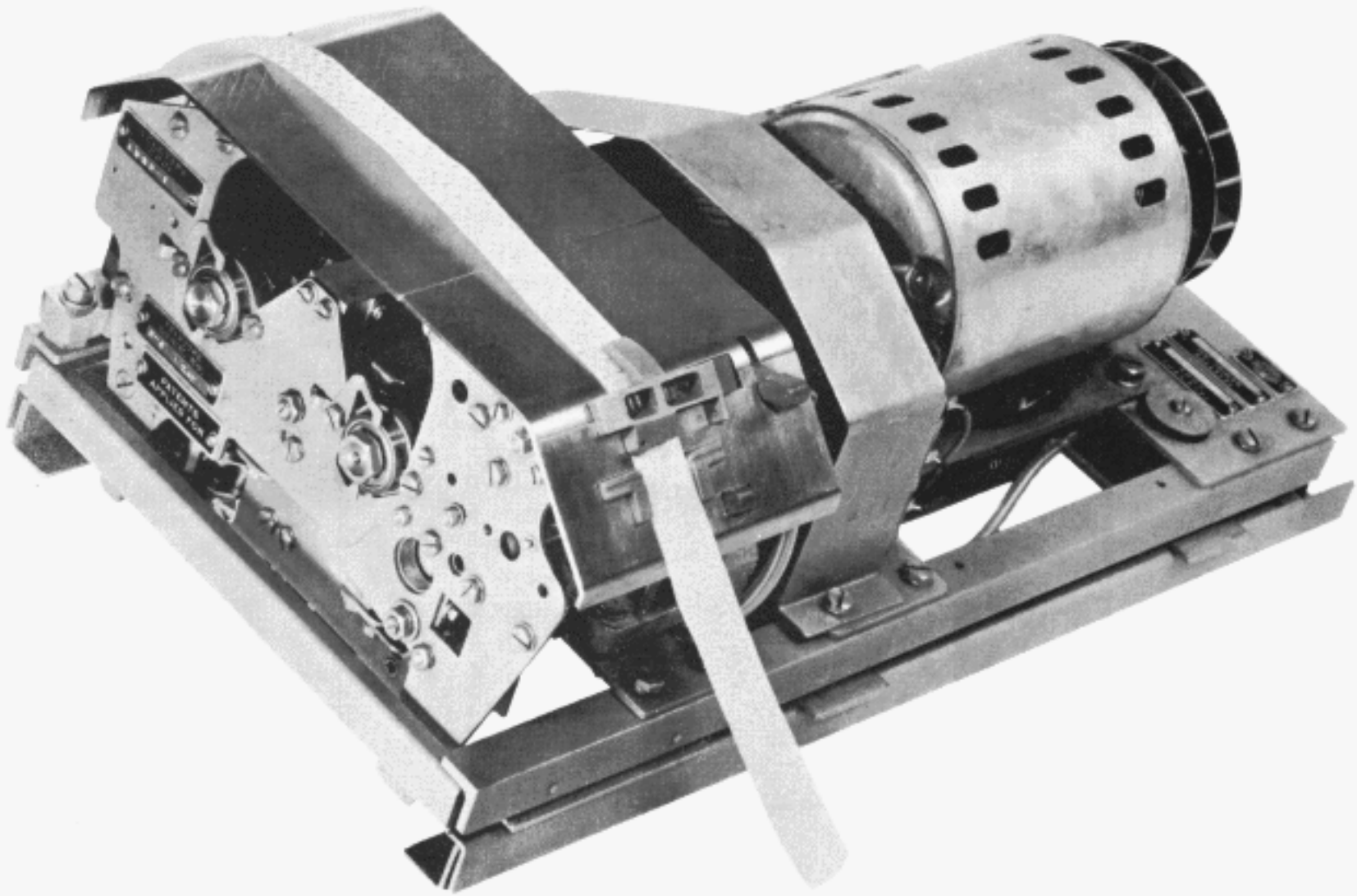

TRANSMITTER DISTRIBUTOR (LBXD) WITH
BASE (LBXB) AND MOTOR UNIT (LMU)

CONTENTS

<u>Paragraph</u>	<u>Page</u>	<u>Paragraph</u>	<u>Page</u>
SECTION 1 BASIC FEATURE ADJUSTMENTS			
1. INTRODUCTION	1-1	Tape-Out Pin	1-21
2. GENERAL	1-1	Tape-Out Switch	1-21
3. ADJUSTMENTS AND SPRING TENSIONS	1-2	Tape-Out Switch Bracket	1-21
a. Transmitter Distributor	1-2	Tight Tape Arm	1-24
		Tight Tape Control Lever	1-24
		Switch	1-24
		Top Plate	1-20
		SPRING TENSIONS	
ADJUSTMENTS		Armature Bail	1-4
Cam Follower Guide	1-7	Auxiliary Lever	1-28
Cam Shaft Bearing Retainer	1-3	Cam Follower Lever	1-7
Cam Sleeve End Play	1-3	Clutch Latch Lever	1-5
Clutch Armature Air Gap	1-4	Clutch Shoe	1-2
Clutch Shoe Lever	1-6	Clutch Shoe Lever	1-2
Clutch Trip Assembly		Clutch Trip Lever	1-5
Mounting Plate	1-4	Contact Slide Lever	1-11
Clutch Trip Lever Upper		Control Lever Detent	1-18
Extension	1-6	Cover Plate Detent	1-32
Contact Slide Lever	1-31	Distributor Rocker	1-8
Clutch Lever Switch Bracket	1-23	Distributor Rocker Compression	1-8
Cover Plate	1-32	Feed Lever	1-10
Distributor Block Assembly	1-9	Feed Pawl	1-27
Distributor Contact Gap	1-9	Feed Ratchet Detent	1-26
Feed Lever Set Collar	1-10	Latch Lever	1-30
Feed Pawl	1-27	Latch Stripper Bail	1-29
Feed Wheel Detent	1-26	Push Lever	1-30
Front Panel	1-32	Push Stripper Bail	1-28
Idler Gear Assembly	1-3	Sensing Bail	1-25
Instructions for Replacing and		Sensing Pin	1-25
Positioning Storing Switch		Slide Lever	1-16
Assembly (Transfer Type)	1-15	Start-Stop Bail Yield	1-23
Magnet Bracket	1-5	Storing Switch Contact Lever	
Oil Reservoir	1-29	Extension	1-11
Push Lever	1-28	Tape Lid	1-18
Sensing Pin	1-25	Tape Lid Release Plunger	1-18
Slide Lever	1-16	Tape-Out Bail Yield	1-22
Storing Switch Assembly	1-15	Tape-Out Extension Bail	1-22
Storing Switch Assembly		Tape-Out Pin	1-22
Replacement	1-12	Tight Tape Bail Yield	1-24
Storing Switch Contacts	1-11	b. Self Contained Set Base (LBXB)	1-33
Storing Switch Contact		ADJUSTMENTS	
Assembly (Transfer Type)	1-13	Intermediate Gear Assembly	1-33
Backstop-Normally Closed		Motor Pinion	1-33
Contact	1-13	c. Multiple Transmitter	
Normally Open Contact Gap	1-14	Distributor Base (LMXB)	1-34
Spring Tension - Normally		ADJUSTMENTS	
Closed Contact	1-13	Counter Shaft	1-35
Spring Tension - Normally		Cover Plates	1-36
Open Contact	1-14	Filler Plates	1-36
Swinger Spring Tension	1-13	Motor Pinion	1-34
Storing Switch Contact Gap	1-31	d. Automatic Send-Receive Set	
Storing Switch Guides	1-11	Transmitter Distributor	
Tape Guide	1-19	Base (LCXB)	1-37
Tape Guide Plate	1-19		
Tape Lid	1-17		

CONTENTS (Cont'd.)

<u>Paragraph</u>	<u>Page</u>	<u>Paragraph</u>	<u>Page</u>
ADJUSTMENTS			
Base (LCXB) Driving Shaft	1-37		
Transmitter Distributor			
Driven Gear	1-37		
e. Synchronous and Governed			
Motors (LMU)	1-38		
ADJUSTMENTS			
Governed Motor Positioning	1-38		
Governor Contact	1-38		
Governor Contact Backstop	1-38		
Governor Motor Speed	1-38		
Synchronous Motor Positioning	1-38		
SPRING TENSIONS			
Governor Brush	1-39		
f. Cabinets	1-40		
ADJUSTMENTS			
Front Door (AC)	1-41		
Front Door Latch (AC)	1-41		
Rear Doors (LBAC)	1-40		
Rear Door Catches (LBAC)	1-40		
Table Top (AC)	1-41		
4. DISTRIBUTOR AND TRANSMITTER			
CONTACT STROBING	1-43		
a. General	1-43		
b. Contact Strobing Procedure -			
1 Cycle Cam	1-44		
(1) Distributor Contacts -			
5 Level Units	1-44		
(a) Preliminary	1-44		
(b) Stop Contact	1-44		
(c) #2 and #4 Contacts	1-45		
(d) #1, #3 and #5 Contacts	1-45		
(2) Distributor Contacts -			
8 Level Units	1-47		
(a) Stop Contact	1-47		
(b) #0, #2, #4 and #6			
Contacts	1-47		
(c) #1, #3, #5 and #7			
Contacts	1-47		
(3) Distributor Auxiliary Con-			
tacts - 5 and 8 Level			
Units	1-48		
(a) Auxiliary "C" Contact			
(LBXD1, 2, 16 and			
18 - 7.00 Unit Code)	1-48		
(b) Auxiliary "C" Contact			
(LBXD1 and 2 -			
7.42 Unit Code)	1-48		
(c) Auxiliary Contact (LBXD			
4, 5, 6, 11, 14 and 23			
7.42 Unit Code)			1-48
(d) Auxiliary "B" Contact			
(LBXD7 and 14 -			
7.42 Unit Code)			1-49
(e) Auxiliary Contact			
(LBXD9 - 7.42			
Unit Code)			1-49
(f) Auxiliary Contact			
(LBXD8 and 22 -			
7.42 Unit Code)			1-49
(g) Auxiliary Contact			
(LBXD800 - 11.00			
Unit Code)			1-49
(h) Auxiliary Contact			
(LBXD17 and 21 -			
7.50 Unit Code)			1-49
(4) Transmitter Contacts -			
5 and 8 Level Units			1-50
(a) Preliminary			1-50
(b) Requirement - LBXD1,			
2, 5, 7, 8, 9, 11, 14, 16,			
17, 21, 22 and 800 (7.42			
and 7.50 Unit Code)			1-50
(c) Requirement - LBXD1,			
2, 11, 16, and 18			
(7.00 Unit Code)			1-50
(d) Requirement - LBXD4,			
6 and 23 (7.42 Unit			
Unit)			1-50
(5) Transmitter Auxiliary			
Contacts (Make-Only			
Type)			1-51
(a) Preliminary			1-51
(b) Requirement - LBXD1,			
2 and 11 (7.42 Unit			
Code)			1-52
(c) Requirement - LBXD4,			
5, 6, 7, 14 and 23			
(7.42 Unit Code)			1-52
(d) Requirement - LBXD1,			
2 and 11 (7.00 Unit			
Code)			1-53
(6) Transmitter Auxiliary			
Contacts (Transfer			
Type)			1-53
(a) Preliminary			1-53
(b) Requirement - LBXD8,			
22, and 800 (7.42			
Unit Code)			1-54
(c) Requirement - LBXD9			
(7.42 Unit Code)			1-54
(d) Requirement - LBXD16			
(7.00 Unit Code)			1-55
(e) Requirement - LBXD18			
(7.00 Unit Code)			1-56
(f) Requirement - LBXD17			
and 21 (7.50 Unit			
Code)			1-57

CONTENTS (Cont'd.)

<u>Paragraph</u>	<u>Page</u>	<u>Paragraph</u>	<u>Page</u>
c. Contact Strobing Procedure - 2 Cycle Cam (LBXD19)	1-58	a. 13 Tight Tape Slide Arm Assembly	3-10
(1) Distributor Contacts - #1 through #5	1-58	a. 14 Start-Stop Slide Arm Assembly	3-10
(2) Distributor Auxiliary "C" Contact	1-58	a. 15 Tape-Out and Tape Lid Mechanism	3-11
(3) Transmitter Contacts - #1 through #5	1-59	a. 16 Tape Lid and Tape Guide	3-12
(4) Transmitter Auxiliary Contacts	1-59	a. 17 Cover Plate	3-13
(a) Requirement - Auxiliary "A" Contact	1-59	a. 18 Deflector Bracket	3-13
(b) Requirement - Auxiliary "B" Contact	1-60	b. Bases	3-14
		b. 01 Motor Unit	3-14
		b. 02 Intermediate Gear Assembly	3-14
		b. 03 LCXB - Base for Transmitter Distributor used in Auto- matic Send-Receive Cabinet	3-15
		b. 04 Drive Gear Assembly	3-16
		c. Cabinets	3-17
SECTION 2 VARIABLE FEATURE ADJUSTMENTS		SECTION 4 DISASSEMBLY AND REASSEMBLY	
ADJUSTMENTS		1. GENERAL	4-1
Line Shunt Switch (160370)	2-4	2. DISASSEMBLY AND REASSEMBLY OF (LBXD) TRANSMITTER DIS- TRIBUTOR	4-1
Line Shunt Switch (172847)	2-4	a. Motor Cover and Front Panel Removal	4-1
Line Shunt Switch (Multiple Base)	2-4	b. Removal of Transmitter Distributor from Base	4-1
Tape Deflector Mechanism	2-3	c. Cover Plate	4-1
Deflector Bracket	2-3	d. Top Plate	4-1
Deflector Spring	2-3	e. Tape Guide Plate	4-1
Tape Lid Pin	2-2	f. Oil Reservoir Assembly	4-1
Tape Lid Spring	2-2	g. Distributor Block Assembly	4-1
Tape-Out Pin Spring Bracket	2-2	h. Idler Gear Assembly	4-1
Tape-Out and Tape Lid Pin Downstop	2-2	i. Distributor Shaft Assembly	4-1
Tape-Out and Tape Lid Switch	2-1	j. Sensing Shaft Assembly	4-1
Tape-Out and Tape Lid Switch Bracket	2-2	k. Feed Wheel Assembly	4-2
		l. Storing Switch Assembly	4-2
		m. Pusher and Latch Levers	4-2
		n. Sensing Pins	4-2
		o. Switch Actuating Mechanism (Start-Stop, and/or Tight Tape)	4-2
		p. Center Plate Assembly	4-2
		q. Sensing Assembly	4-2
		r. Clutch Trip Assembly	4-2
		s. Frame Assembly	4-2
		3. DISASSEMBLY AND REASSEMBLY OF BASE (LCXB) THAT SUPPORTS THE TRANSMITTER DISTRIBUTOR ON THE AUTOMATIC SEND- RECEIVE SET	4-3
		a. Housing	4-3
		b. Front Cover Plate	4-3
SECTION 3 LUBRICATION			
1. INTRODUCTION	3-1		
2. GENERAL	3-1		
3. LUBRICATION	3-2		
a. Transmitter Distributor	3-2		
a. 01 Clutch Trip Assemblies	3-2		
a. 02 Storing Switch Assemblies	3-3		
a. 03 Distributor and Sensing Shaft Assemblies	3-4		
a. 04 Distributor Block Assembly	3-5		
a. 05 Clutch Assemblies	3-5		
a. 06 Oil Reservoir	3-6		
a. 07 Tape Sensing Mechanism	3-7		
a. 08 Latch and Pusher Stripper Bail	3-7		
a. 09 Pusher Levers	3-8		
a. 10 Feed Mechanism	3-8		
a. 11 Feed Mechanism	3-9		
a. 12 Tape-Out and Control Mechanism	3-10		

CONTENTS (Cont'd.)

<u>Paragraph</u>	<u>Page</u>	<u>Paragraph</u>	<u>Page</u>
c. Mounting Screws	4-3	a. Mounting	4-4
d. Cable Connectors	4-3	b. Transmitter-Distributor Unit	4-4
e. Driving Gear Assembly (Speed Change Requirements)	4-3	5. DISASSEMBLY AND REASSEMBLY OF MULTIPLE MOUNTED TRANS- MITTER DISTRIBUTOR UNITS	4-6
f. Base Mounting Hardware	4-3	a. General	4-6
4. DISASSEMBLY AND REASSEMBLY OF THE APPARATUS CABINET FOR HOUSING ONE OR TWO SELF- CONTAINED TRANSMITTER DIS- TRIBUTOR UNITS - AC	4-4	b. Transmitter Distributor Unit, Multiple Mounted	4-6
		c. Base for Multiple Arrangement	4-6

SECTION 1

BASIC FEATURE ADJUSTMENTS

1. INTRODUCTION

a. This bulletin presents maintenance information for the Teletype Model 28 LBXD Transmitter Distributor. It is divided into four sections covering, respectively, basic feature adjustments, variable feature adjustments, lubrication, and disassembly and reassembly.

b. It is assumed that the mechanisms illustrated in this bulletin are being viewed from a position in front of the equipment, unless the illustrations are specifically labeled otherwise. In the line drawings, fixed pivot points are shown by solid black circles and moveable points are shown by cross-hatched circles. References in the text to LEFT or RIGHT, UP or DOWN, FRONT or REAR apply to the unit in its normal operating position with the reading head to the viewer's right.

2. GENERAL

a. Section 1 contains adjustment information common to all LBXD Transmitter Distributor units. Also included in this section is the strobing procedure to be followed for proper timing of the transmitter and distributor contacts.

b. In the adjustments and spring tensions covered in this section, location of clearance, position of parts, and point and angle of scale applications are illustrated by drawings. A complete adjusting procedure should be read before making the adjustment or checking the spring tension. The adjustments are arranged in a sequence that should be followed if a complete re-adjustment of the unit were undertaken.

c. The spring tensions given in this bulletin are indicated values and should be checked with Teletype scales in the positions shown in the drawings. Springs which do not meet the requirements, and for which there are no adjusting procedures, should be discarded and replaced by new springs.

d. When rotating the drive shaft gear by

hand, the rotation is counterclockwise as viewed from the exposed side of the drive shaft gear.

e. When the requirement calls for a clutch to be DISENGAGED, the clutch shoe lever must be fully latched between its trip lever and latch lever so that the clutch shoes release their tension on the clutch drum. When ENGAGED, the clutch shoe lever is unlatched and the clutch shoes are wedged firmly against the clutch drum.

NOTE

When rotating either the sensing or distributor shaft by hand, the respective clutch may not fully disengage upon reaching its stop position. To disengage the clutch, rotate the clutch to its stop position, apply a screwdriver to the cam disk stop lug, and move the disk in the normal direction of the shaft rotation until the latch lever seats in its notch in the disk.

f. Tools required to make adjustments and check spring tensions are not supplied with the equipment, but are listed in Teletype Bulletin 1124B. If parts are removed, all adjustments which the removal of parts might facilitate should be made before the parts are replaced. When a part mounted on shims is removed, the number of shims at each mounting screw should be noted so that the identical shim pile-up can be made when the part is remounted. Unless stated otherwise, all nuts and screws that were loosened should be tightened after an adjustment has been made.

g. The covers may be removed for inspection and minor repair of the unit. However, when more extensive maintenance is to be undertaken, it is recommended that the unit be removed from its sub-base to disconnect the power and to permit the unit to be inverted.

h. All contact points should meet squarely. Contacts with the same diameter should not be out of alignment more than 25% of the contact diameter. Avoid sharp kinks or bends in the contact springs.

3. ADJUSTMENTS AND SPRING TENSIONS

a. TRANSMITTER DISTRIBUTOR

NOTE: REQUIREMENTS A AND B ARE ADJUSTED AT THE FACTORY AND SHOULD NOT BE DISTURBED UNLESS ASSOCIATED MECHANISMS HAVE BEEN REMOVED FOR SERVICING OR THERE IS REASON TO BELIEVE THAT THE REQUIREMENTS ARE NOT MET. THE FOLLOWING REQUIREMENTS APPLY TO BOTH THE SENSING CLUTCH AND DISTRIBUTOR CLUTCH.

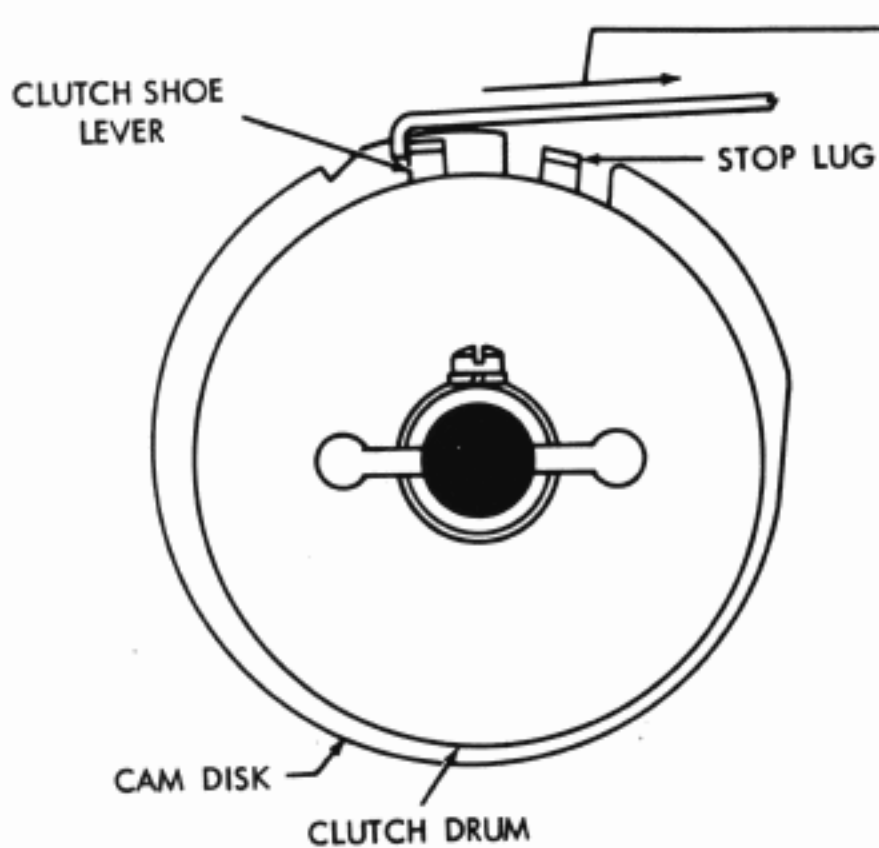
(A) CLUTCH SHOE LEVER SPRING

REQUIREMENT

CLUTCH ENGAGED AND CAM DISK HELD TO PREVENT TURNING. SCALE PULLED AT TANGENT TO CLUTCH. MIN. 15 OZS. MAX. 20 OZS.

TO MOVE CLUTCH SHOE LEVER IN CONTACT WITH STOP LUG.

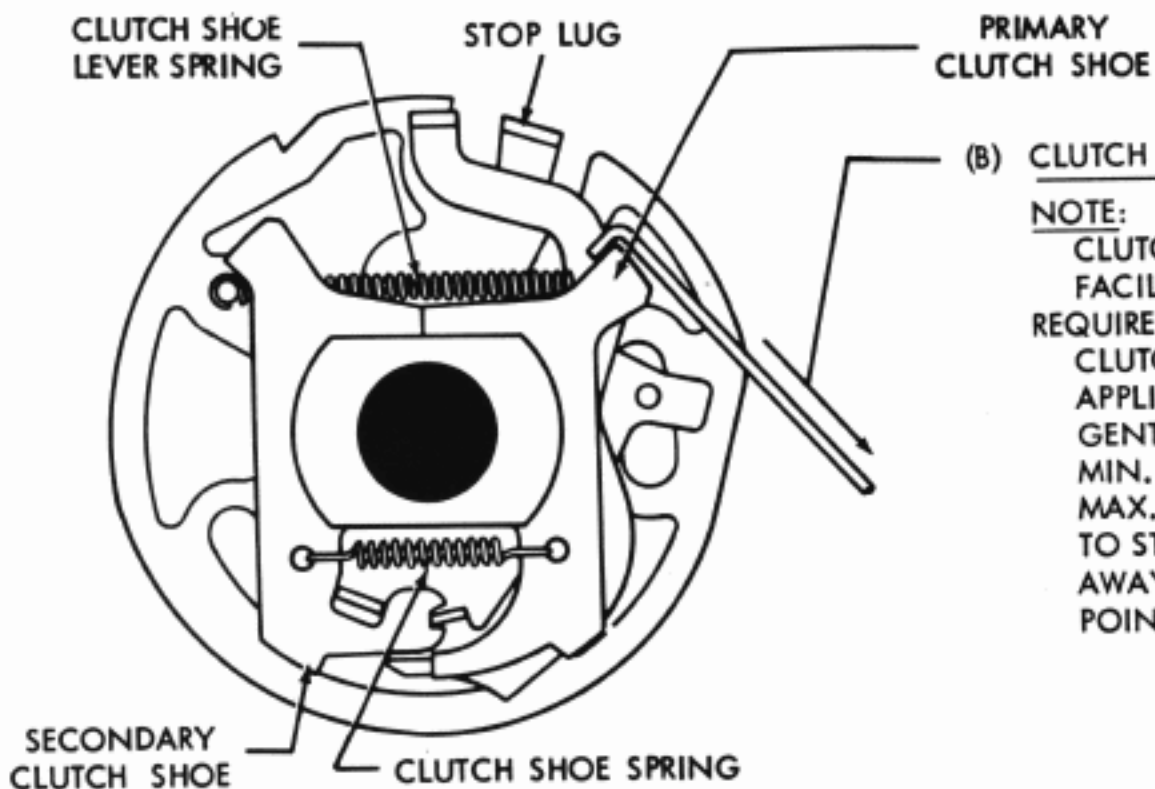
(B) CLUTCH SHOE SPRING

NOTE: IT IS NECESSARY TO REMOVE THE CLUTCH FROM THE MAIN SHAFT TO FACILITATE THIS CHECK.

REQUIREMENT

CLUTCH DRUM REMOVED. SCALE APPLIED TO PRIMARY SHOE AT A TANGENT TO THE FRICTION SURFACE. MIN. 3 OZS. MAX. 5 OZS.

TO START PRIMARY SHOE MOVING AWAY FROM SECONDARY SHOE AT POINT OF CONTACT.

FIGURE 1-1. CLUTCH MECHANISM

NOTE: THE FOLLOWING REQUIREMENTS APPLY TO BOTH THE DISTRIBUTOR AND SENSING CAM SLEEVES. THESE MECHANISMS SHOULD NOT BE DISTURBED UNLESS THERE IS REASON TO BELIEVE THE REQUIREMENTS ARE NOT MET.

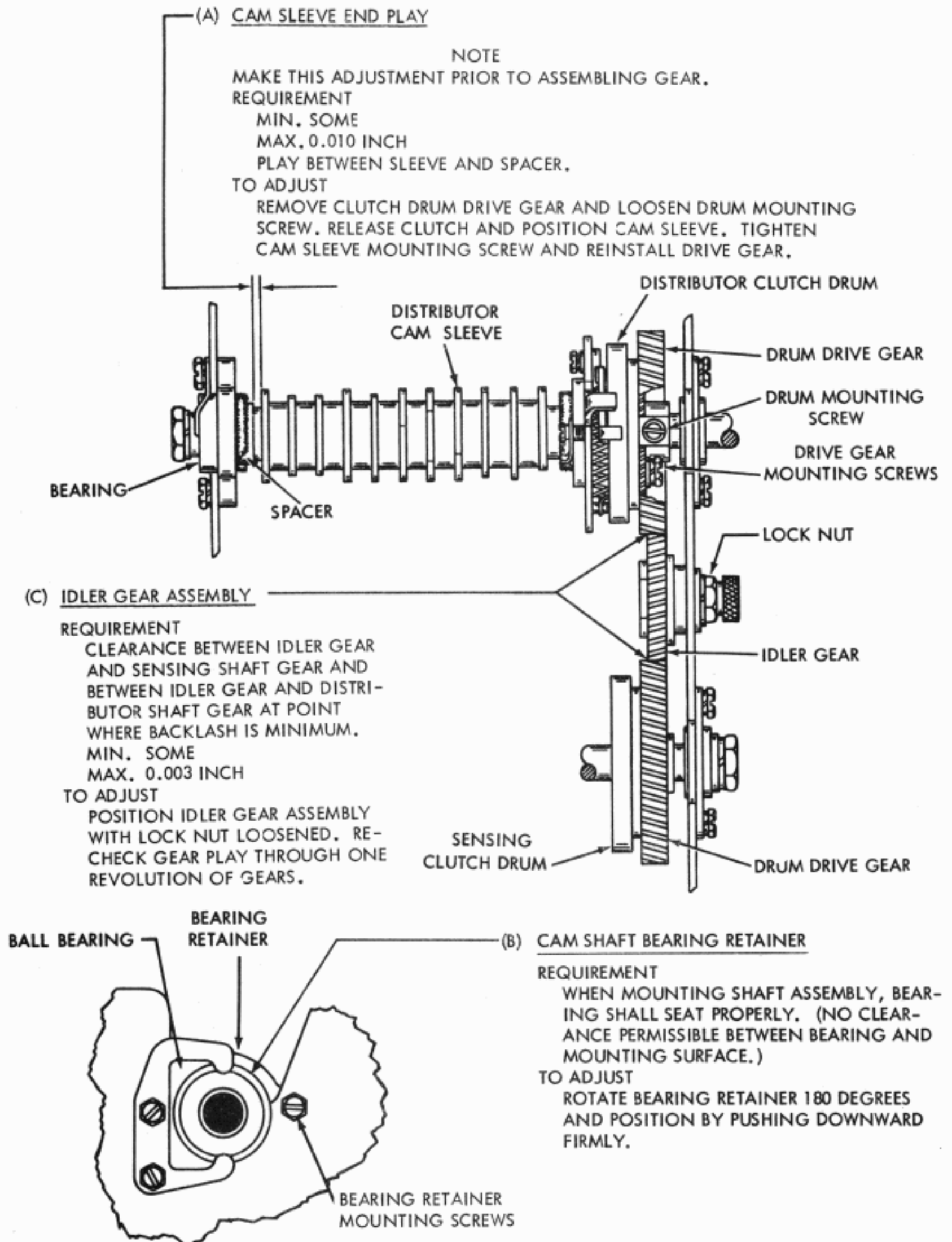

FIGURE 1-2. CAM SHAFTS

NOTE: REQUIREMENTS APPLY TO BOTH CLUTCH TRIP MECHANISMS.

(A) CLUTCH ARMATURE AIR GAP

REQUIREMENT

AIR GAP BETWEEN ARMATURE AND MAGNET ASSEMBLY BRACKET WITH ARMATURE FLUSH AGAINST MAGNET CORE.

MIN. 0.004 INCH
MAX. 0.008 INCH

TO ADJUST

REMOVE ARMATURE EXTENSION SPRING. POSITION HINGE WITH SPRING POST AND HINGE MOUNTING SCREW LOOSENED. RECHECK AIR GAP AND REPLACE SPRING.

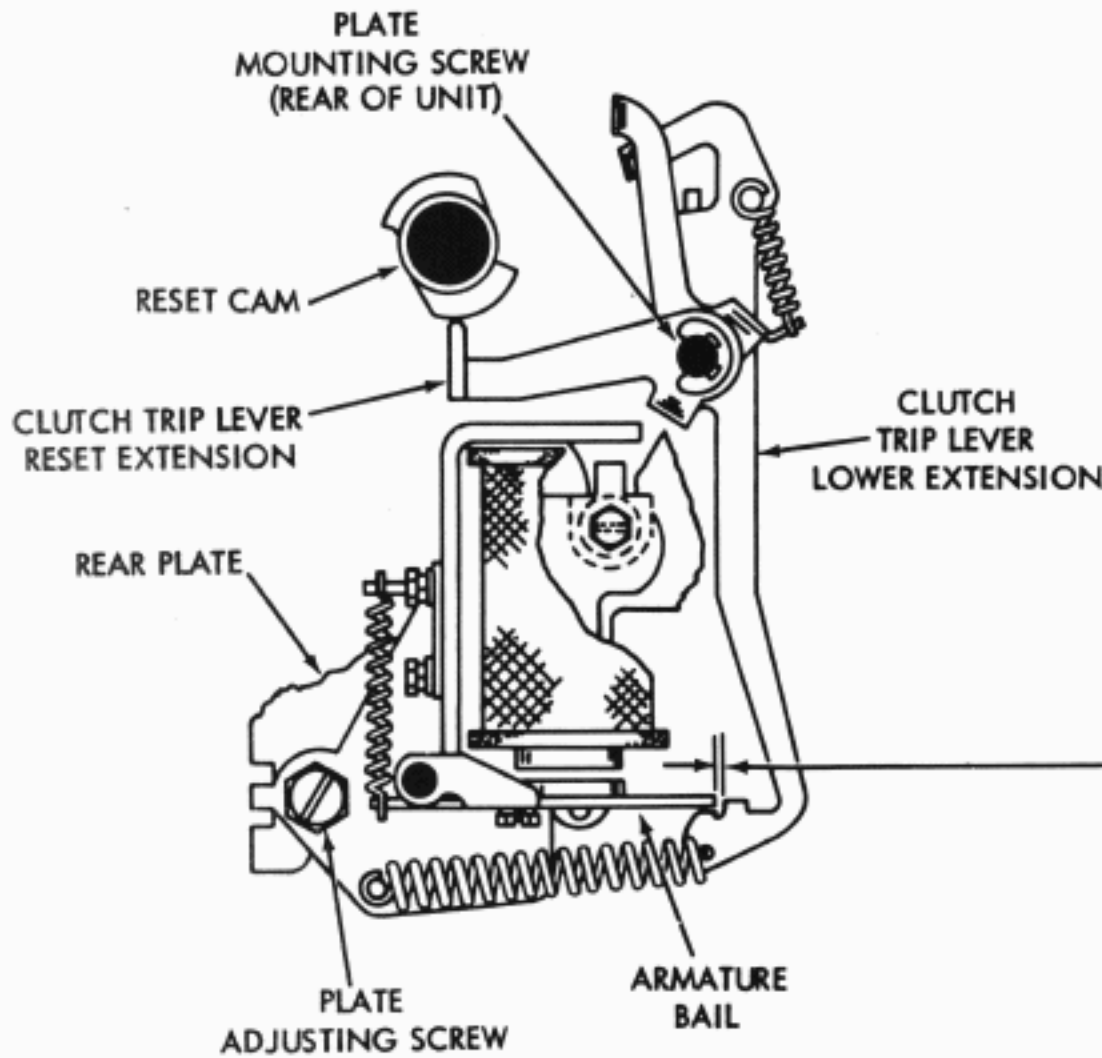
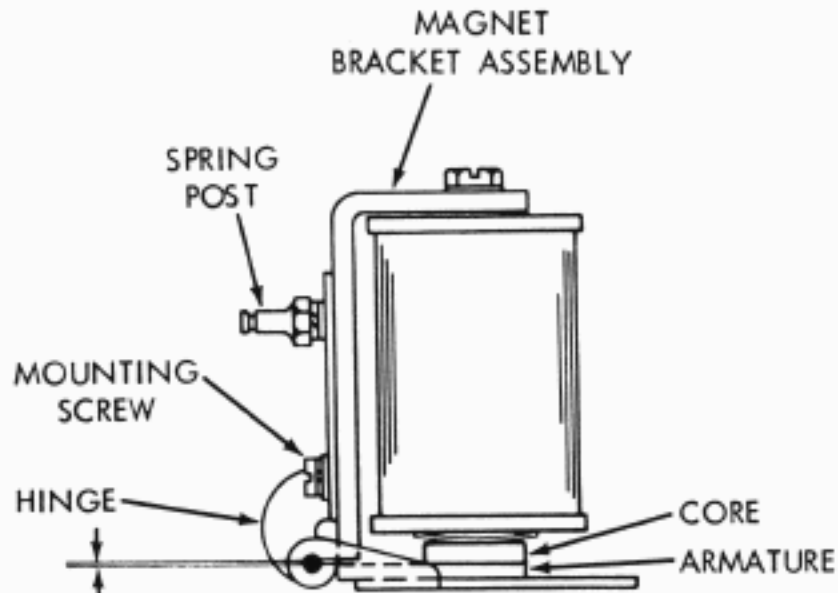

(B) CLUTCH TRIP ASSEMBLY MOUNTING PLATE

REQUIREMENT

CLEARANCE BETWEEN END OF ARMATURE BAIL AND LATCHING SURFACE OF CLUTCH TRIP LEVER LOWER EXTENSION WITH CLUTCH TRIP LEVER RESET EXTENSION ON HIGH PART OF CAM. (TAKE-UP PLAY IN PARTS FOR MINIMUM CLEARANCE.)

MIN. 0.020 INCH
MAX. 0.030 INCH

TO ADJUST

POSITION PLATE WITH SCREWDRIVER IN LOWER ADJUSTING SLOT WITH PLATE ADJUSTING SCREW AND PLATE MOUNTING SCREW LOOSENED. (TAKE-UP PLAY IN TRIP LEVER IN DIRECTION OF CAM.)

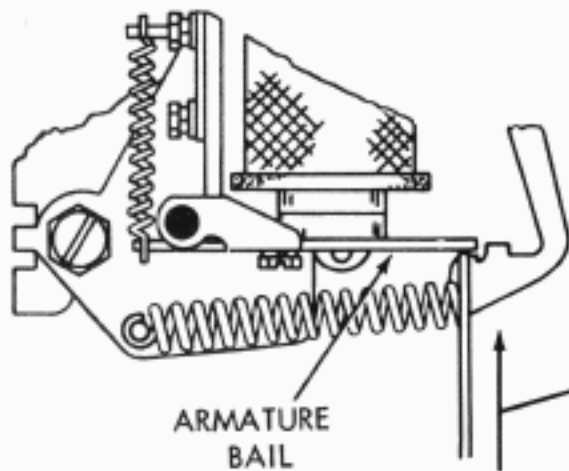

(C) ARMATURE BAIL SPRING

REQUIREMENT

TRIP LEVER RESET EXTENSION ON HIGH PART OF CAM. SCALE APPLIED TO LATCHING END OF ARMATURE BAIL.

MIN. 3 OZS.
MAX. 4-1/2 OZS.

TO START ARMATURE BAIL MOVING.

FIGURE 1-3. CLUTCH TRIP MECHANISM

NOTE: REFER TO REQUIREMENTS IN PRECEDING PAGE.

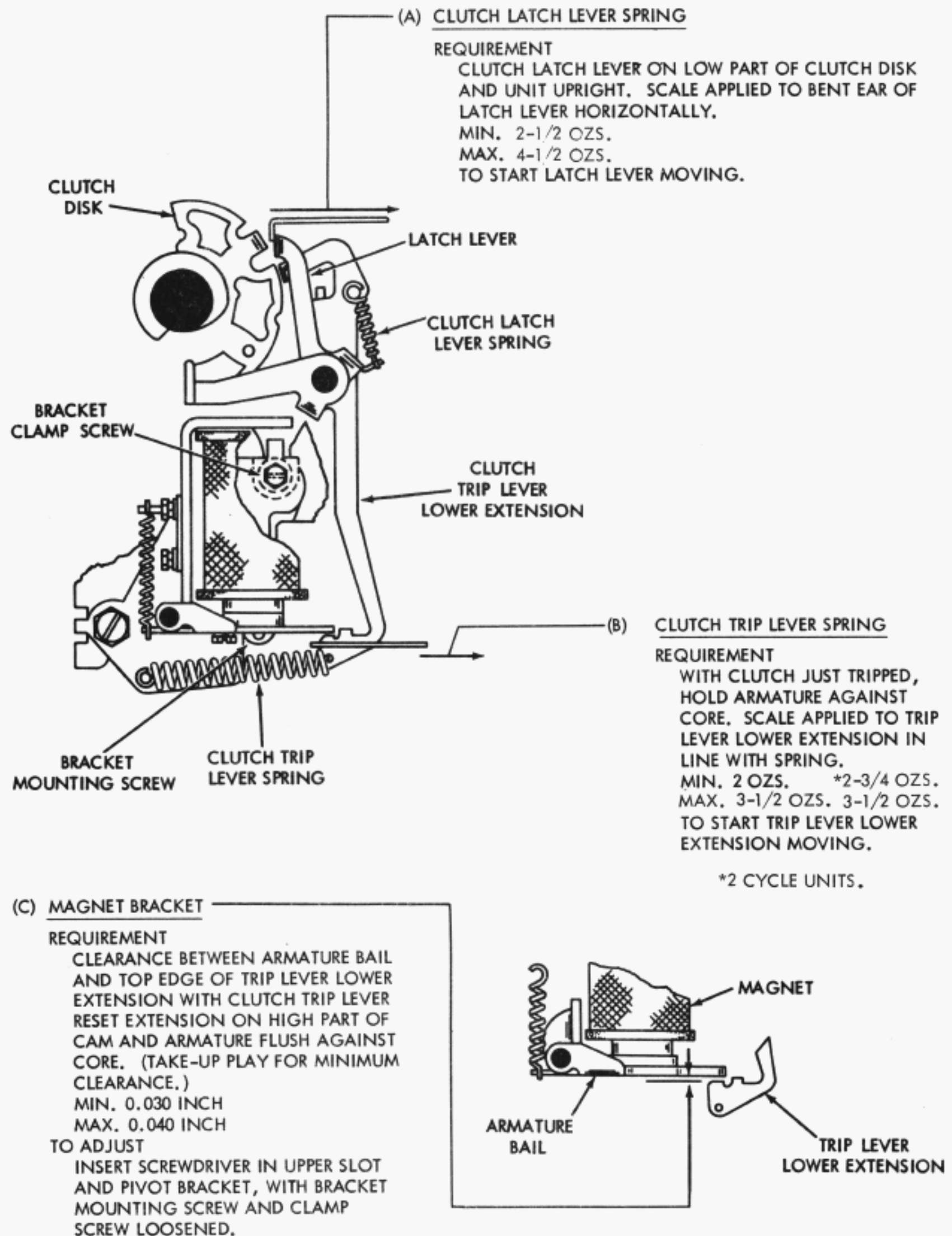

FIGURE 1-4. CLUTCH TRIP MECHANISM

NOTE: REQUIREMENTS A AND B APPLY TO BOTH CLUTCHES.

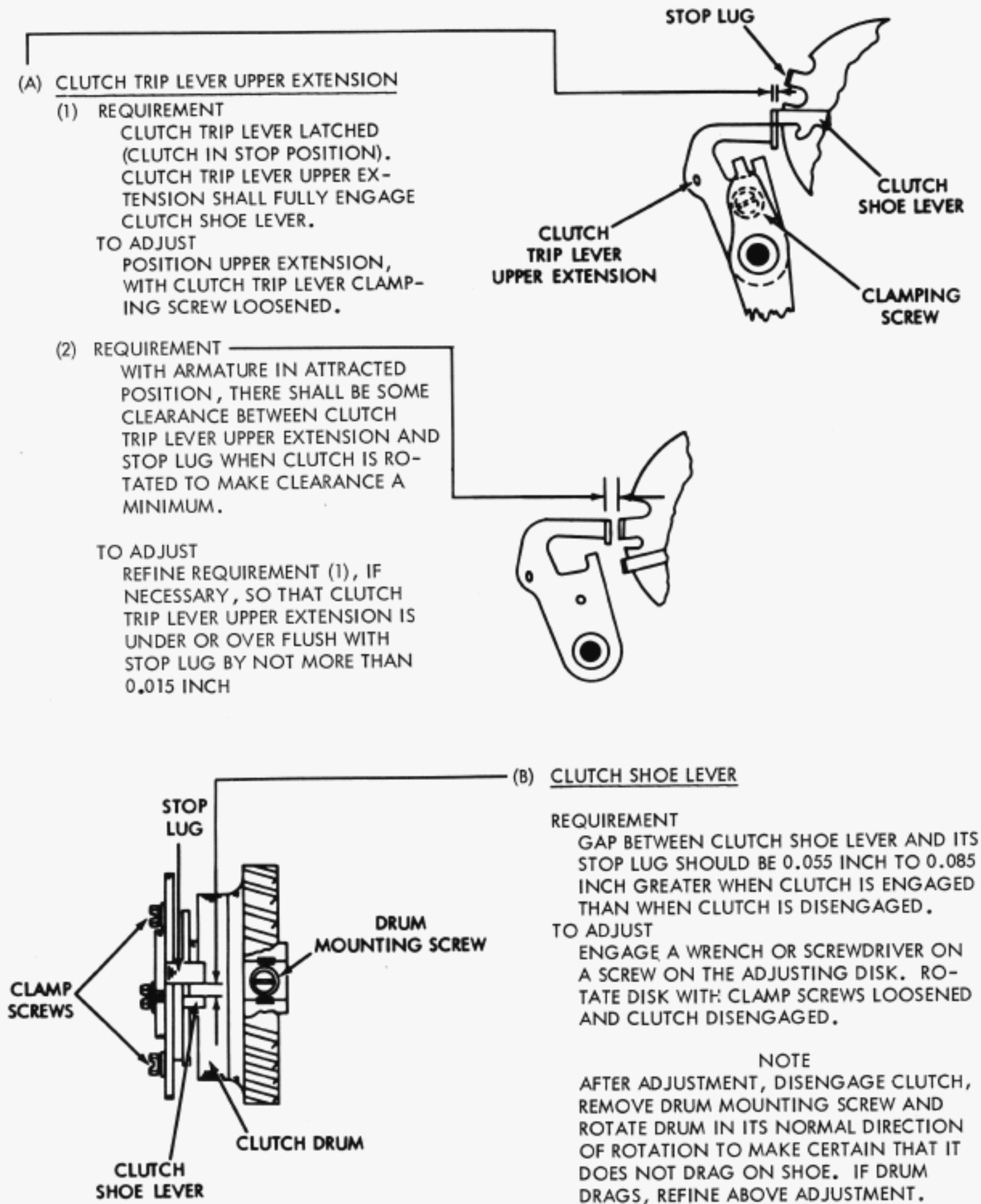

FIGURE 1-5. CLUTCH MECHANISM

NOTE

REMOVE OIL RESERVOIR AND DISTRIBUTOR BLOCK ASSEMBLY TO FACILITATE ADJUSTMENT.

(A) CAM FOLLOWER GUIDE
REQUIREMENT

- (1) CENTER CAM FOLLOWER ENGAGES CAM BY FULL THICKNESS OF FOLLOWER WHEN MOVED FROM SIDE TO SIDE IN ITS GUIDE SLOT.
- (2) IN SIMILAR MANNER, OTHER FOLLOWER SHOULD ENGAGE CAM BY AT LEAST 75% OF FOLLOWER THICKNESS.
- (3) ALL FOLLOWERS MOVE FREELY IN THEIR GUIDE SLOTS.

TO ADJUST

POSITION CAM FOLLOWER GUIDE WITH ITS MOUNTING SCREWS LOOSENED.

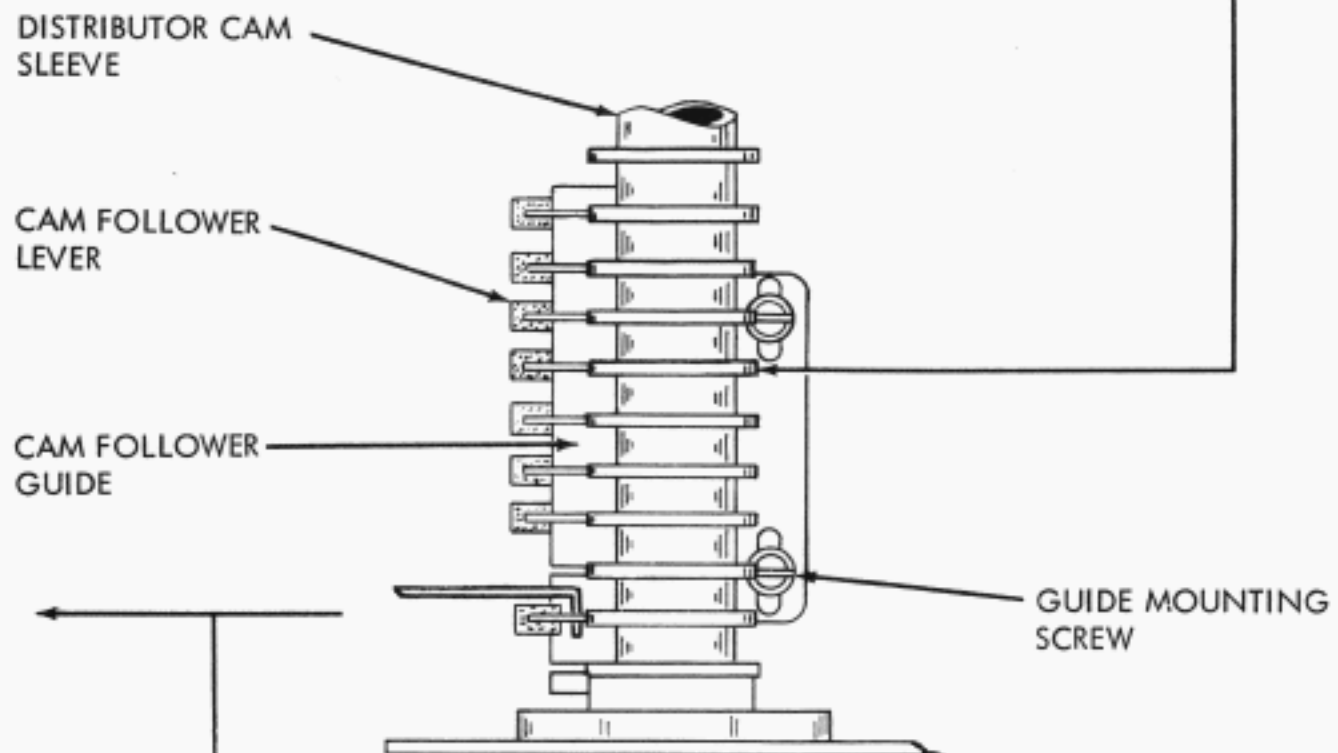

(B) CAM FOLLOWER LEVER SPRING
REQUIREMENT

CAM FOLLOWER LEVER ON HIGH PART OF CAM. SCALE APPLIED JUST BELOW SLIDING SURFACE OF LEVER HORIZONTALLY.

MIN. 1/2 OZ.

MAX. 1-1/2 OZS.

TO START EACH LEVER MOVING.

FIGURE 1-6. DISTRIBUTOR CONTACT MECHANISM

(A) DISTRIBUTOR ROCKER SPRING
TO CHECK

POSITION EACH CONTACT SCREW SO ITS CONTACT SURFACE IS ABOUT 1/32 INCH FROM EDGE OF BLOCK.

REQUIREMENT

WITH COMPRESSION SPRINGS REMOVED, HOLD DISTRIBUTOR BLOCK IN HORIZONTAL POSITION. PUSH SPRING SCALE DOWNWARD (VERTICALLY).

MIN. 3 OZS.

MAX. 4 OZS.

TO SEPARATE CONTACTS.

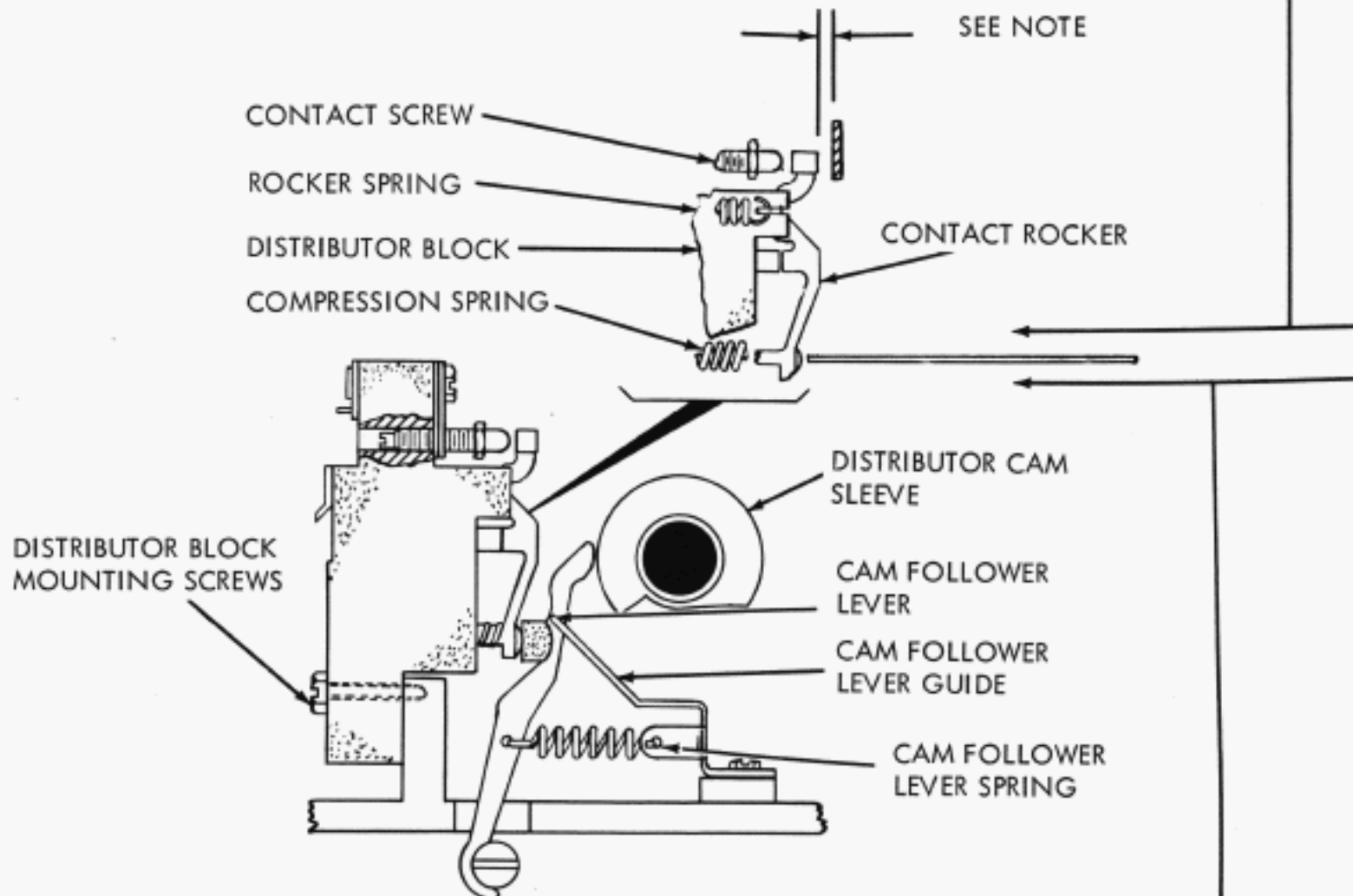
(B) DISTRIBUTOR ROCKER COMPRESSION SPRINGS
REQUIREMENT

WITH COMPRESSION SPRINGS INSTALLED, AND BLOCK IN A HORIZONTAL POSITION, APPLY SPRING SCALE AT LOWER END OF ROCKER AND PUSH DOWNWARD.

MIN. 6-1/2 OZS.

MAX. 9-1/2 OZS.

TO SEPARATE CONTACTS.

NOTE

WITH DISTRIBUTOR BLOCK REMOVED, ADJUST CONTACTS SO THAT THERE IS 0.070 TO 0.080 INCHES BETWEEN ROCKER LEVERS AND OIL GUARD.

FIGURE 1-7. DISTRIBUTOR CONTACT MECHANISM

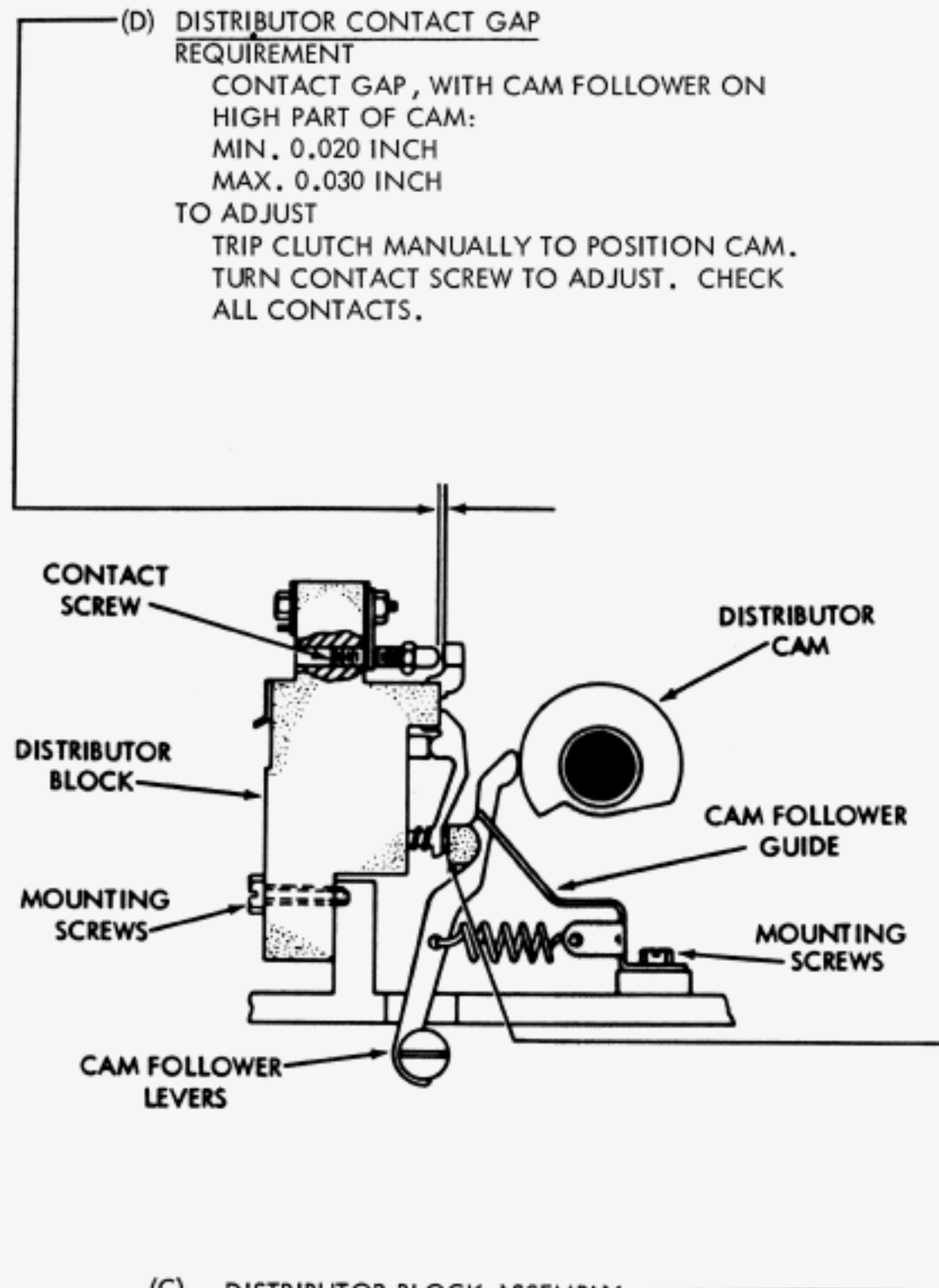

NOTE
 FOR REFINEMENT OF DISTRIBUTOR CONTACT ADJUSTMENTS, REFER TO PARAGRAPH 4,
 DISTRIBUTOR AND TRANSMITTER CONTACT STROBING.

FIGURE 1-8. DISTRIBUTOR CONTACT MECHANISM

(A) FEED LEVER SET COLLAR

REQUIREMENT

MIN. SOME

MAX. 0.015 INCH

CLEARANCE BETWEEN FEED LEVER AND
COLLAR WHEN FEED LEVER IS FREE IN
ITS GUIDE SLOT.

TO ADJUST

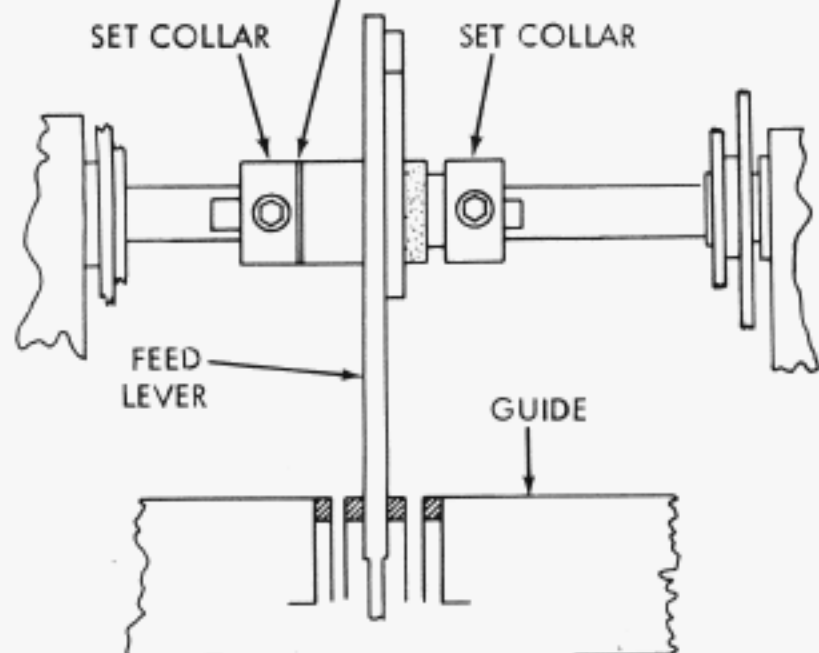
POSITION FEED LEVER WITH SET COLLAR
SCREWS LOOSENED. FEED LEVER SHOULD
MOVE FREELY WITHOUT BINDING AT
GUIDE OR COLLARS.

NOTE

AFTER TIGHTENING SET SCREWS, RECHECK
ADJUSTMENT FOR BINDS BETWEEN FEED LEVER
AND COLLARS, AND BETWEEN FEED LEVER
AND GUIDE.(B) FEED LEVER SPRING

TO CHECK

ROTATE SENSING SHAFT UNTIL CLUTCH IS
IN STOP POSITION.

REQUIREMENT

MIN. 10 OZS.

MAX. 17 OZS.

TO MOVE FEED LEVER AWAY FROM CAM.

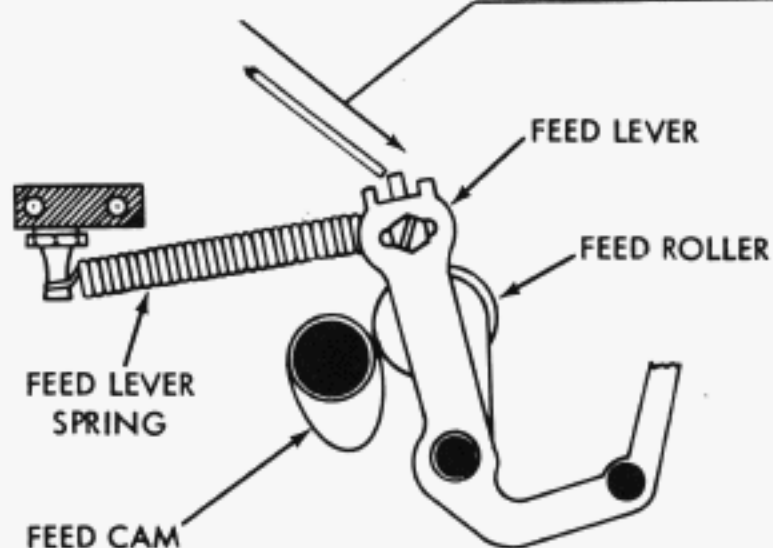

NOTE

ON "FEED BEFORE READ" UNITS, THIS ADJUSTMENT
IS MADE WITH THE FEED LEVER CAM FOLLOWER ROLLER
ON THE LOW PART OF THE SENSING CAM

FIGURE 1-9. FEED LEVER MECHANISM

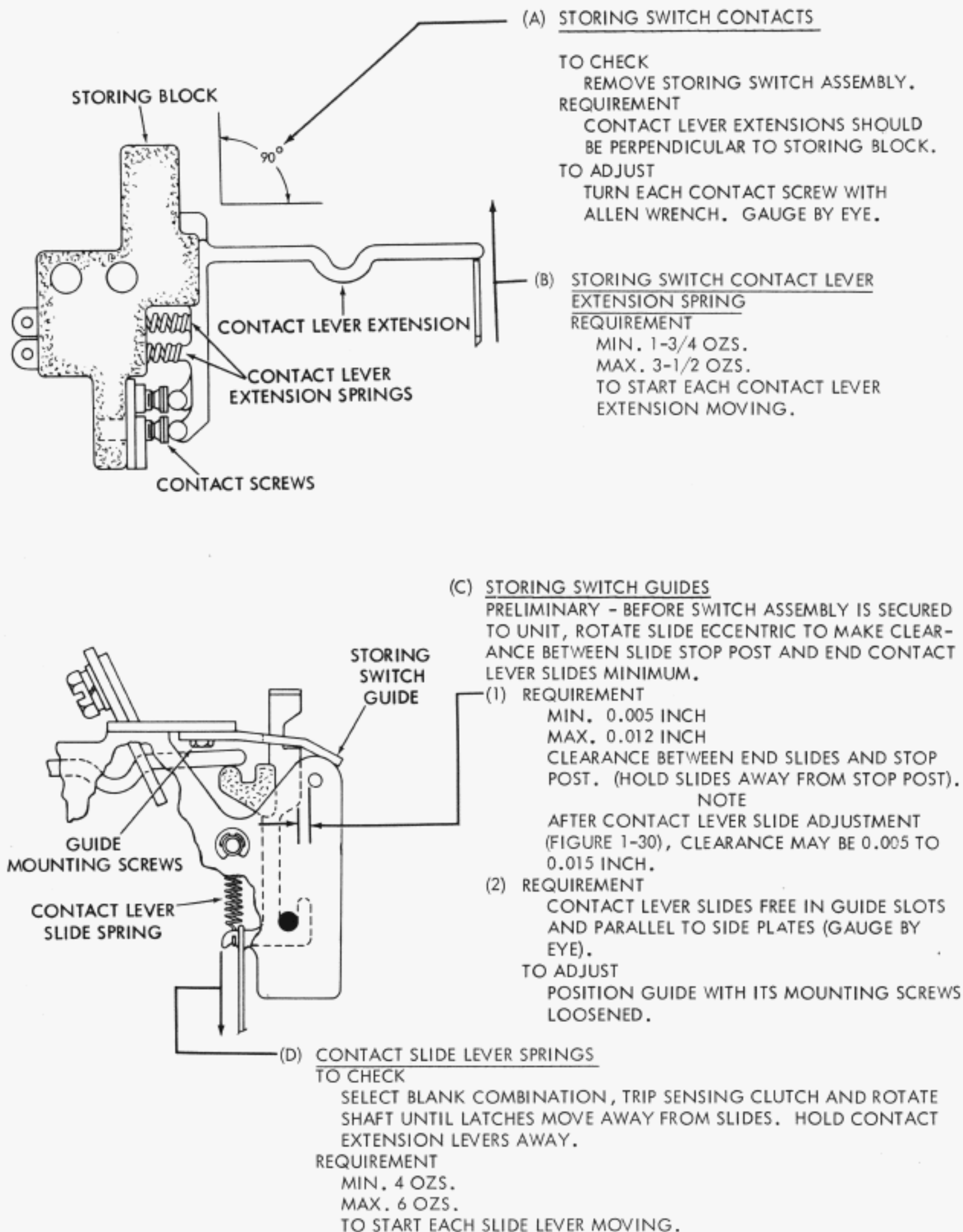

FIGURE 1-10. STORING SWITCH MECHANISM

STORING SWITCH ASSEMBLY REPLACEMENT**REQUIREMENT**

STORING SWITCH ASSEMBLY SHOULD ALIGN WITH LATCH LEVERS SO THAT LATCH LEVERS AND SLIDES FUNCTION WITHOUT BINDING.

TO CHECK

MANUALLY PUSH LATCH BAIL FOLLOWER AWAY FROM CAM UNTIL LATCHES ARE FREE FROM GUIDE. RELEASE LATCH BAIL FOLLOWER AND NOTE IF LATCHES FALL INTO THEIR RESPECTIVE SLOTS.

TO ADJUST

PIVOT STORING SWITCH WITH STORING SWITCH MOUNTING SCREWS LOOSENED. RECHECK REQUIREMENT.

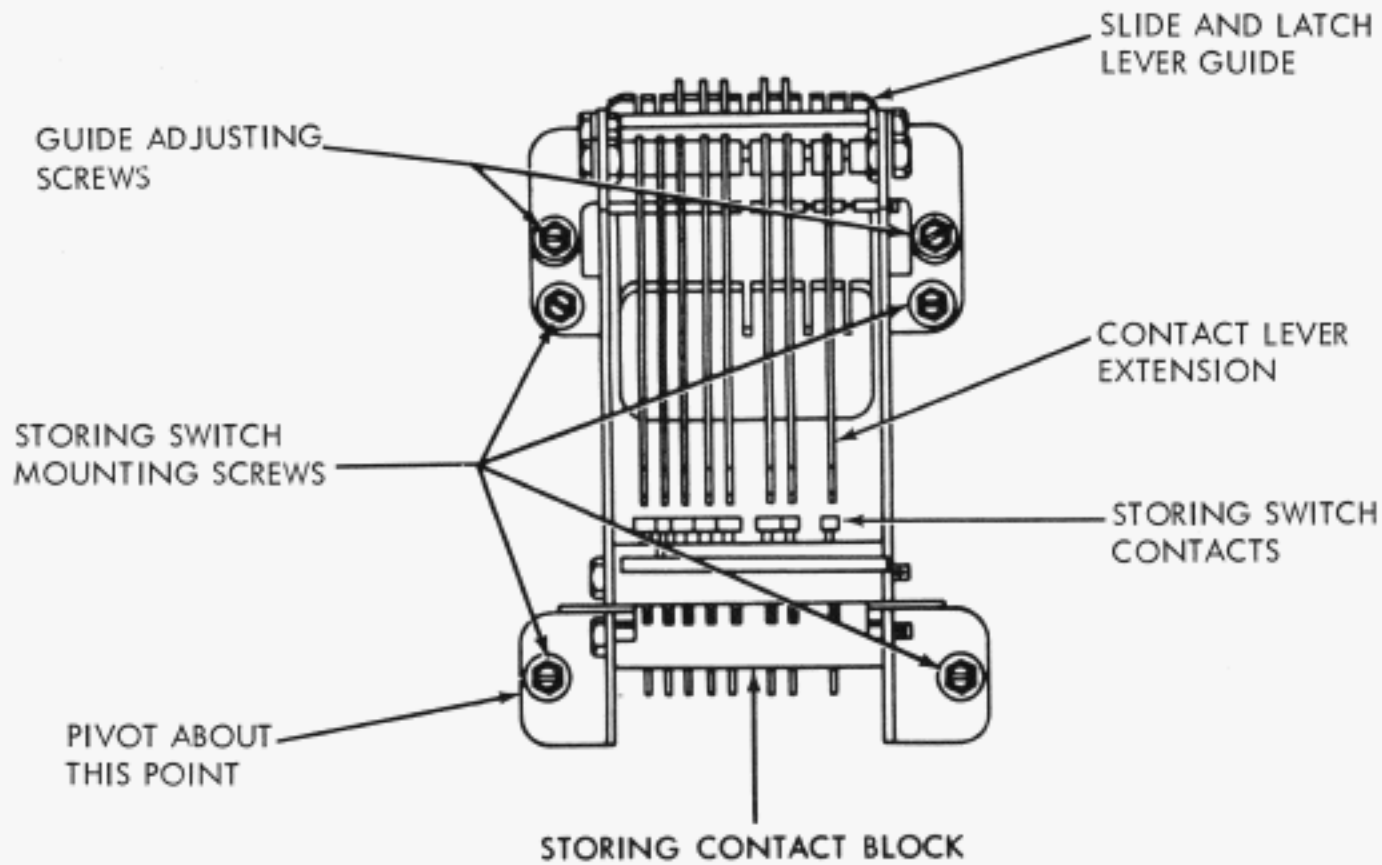
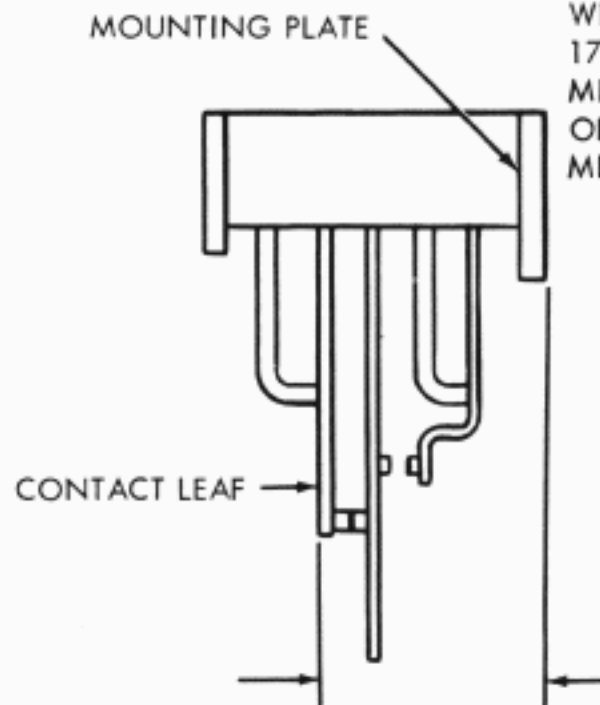

FIGURE 1-11. STORING SWITCH MECHANISM

STORING SWITCH CONTACT ASSEMBLY (TRANSFER TYPE)

NOTE

FOLLOWING ADJUSTMENTS (FIGURES 1-12 AND 1-13) ARE TO BE MADE WITH THE CONTACT ASSEMBLIES REMOVED FROM THE UNIT. USE A 172060 ADJUSTING TOOL TO BEND THE CONTACTS. FOR EACH ADJUSTMENT START WITH THE CONTACT PILE-UP FARTHEST FROM THE HANDLE OF THE BENDING TOOL TO AVOID DISTURBING COMPLETED ADJUSTMENTS.

(1) BACKSTOP - NORMALLY CLOSED CONTACT REQUIREMENT

FIVE OR EIGHT NORMALLY CLOSED CONTACT LEAFS PARALLEL TO MOUNTING PLATE AND IN LINE WITH EACH OTHER AS GAUGED BY EYE.

TO ADJUST
BEND BACKSTOP.

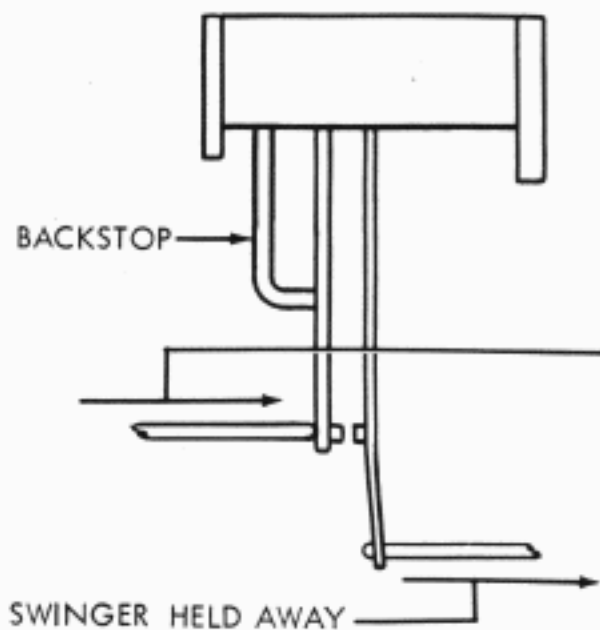
(2) SPRING TENSION - NORMALLY CLOSED CONTACT REQUIREMENT

WITH SWINGER CONTACT HELD AWAY

MIN. 2 OZS.

MAX. 6 OZS.

TO MOVE EACH NORMALLY CLOSED LEAF AWAY FROM BACKSTOP.

TO ADJUST
BEND NORMALLY CLOSED LEAF SPRING

NOTE

TO INCREASE TENSION OF NORMALLY CLOSED LEAF, IT MAY BE NECESSARY TO BEND BACKSTOP AWAY FROM LEAF, BEND LEAF, AND THEN REMAKE ADJUSTMENT (1).

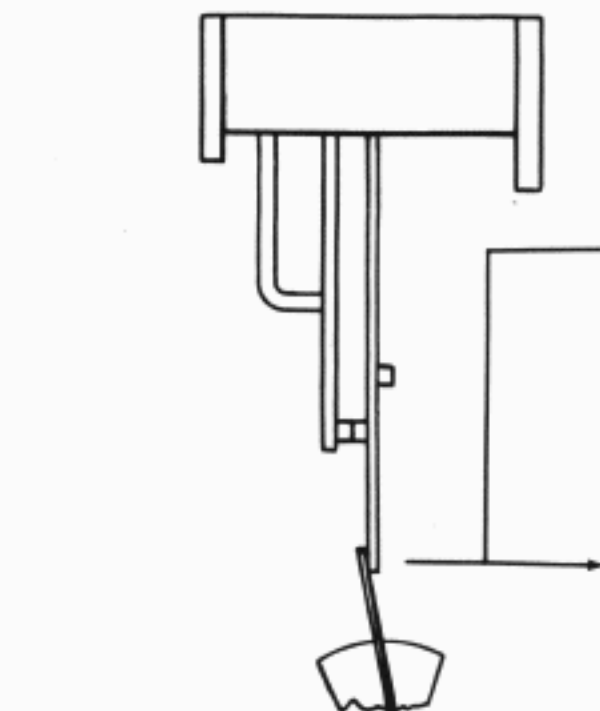
(3) SWINGER SPRING TENSION REQUIREMENT

MIN. 35 GRAMS

MAX. 50 GRAMS

TO OPEN NORMALLY CLOSED CONTACT

TO ADJUST
BEND SWINGER LEAF

FIGURE 1-12. TRANSFER TYPE STORING SWITCH MECHANISM

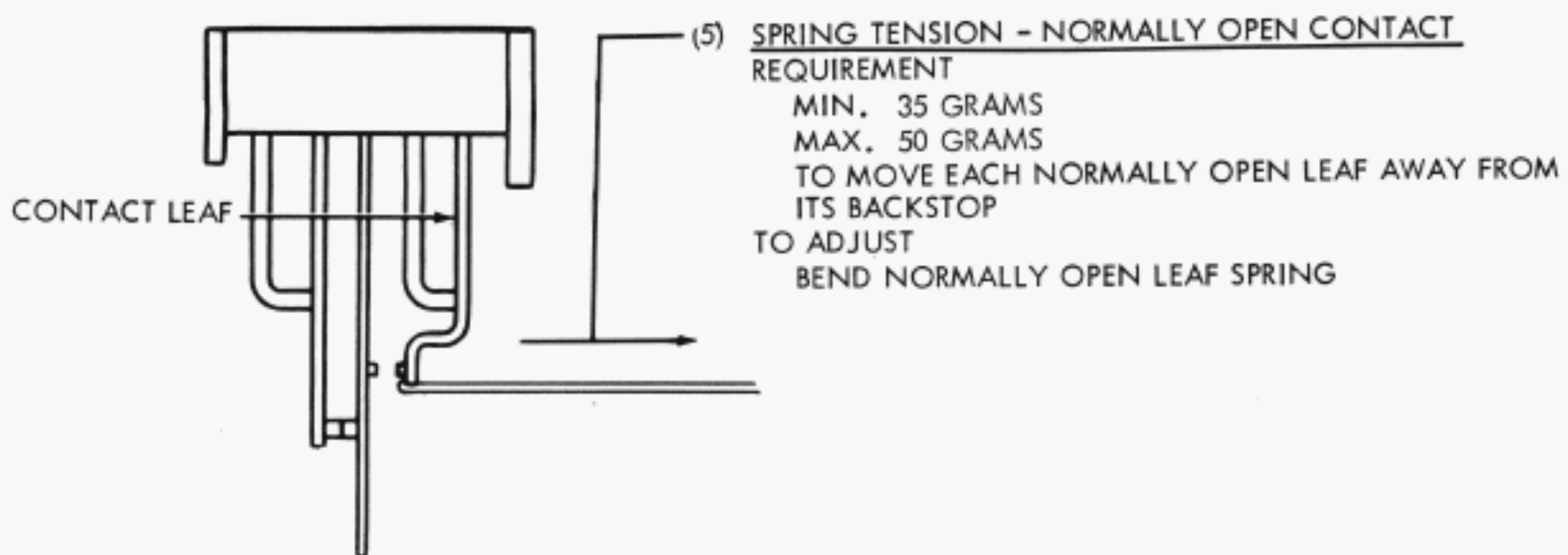
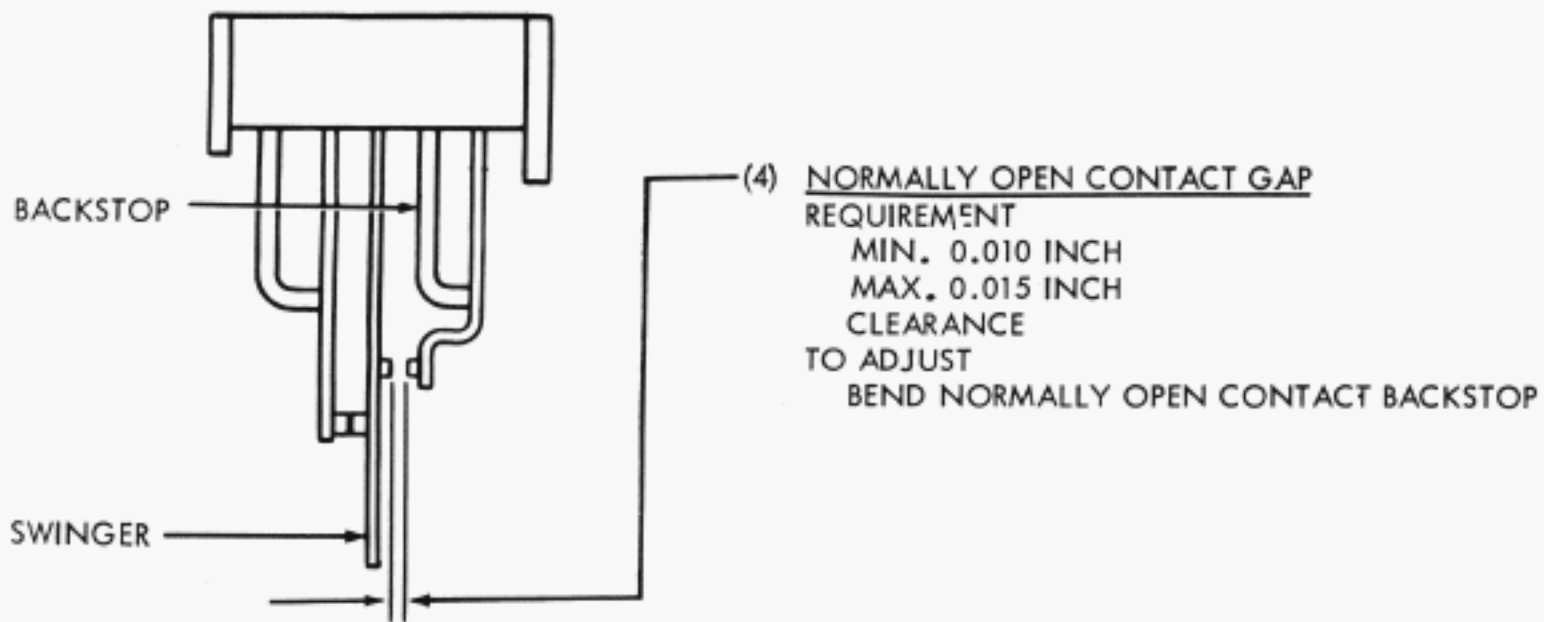

NOTE
 TO INCREASE TENSION OF NORMALLY OPEN LEAF SPRING,
 IT MAY BE NECESSARY TO BEND BACKSTOP AWAY FROM
 LEAF, BEND LEAF, AND THEN REMAKE ADJUSTMENT (5).

FIGURE 1-13. TRANSFER TYPE STORING SWITCH MECHANISM

INSTRUCTIONS FOR REPLACING AND POSITIONING STORING SWITCH ASSEMBLY (TRANSFER TYPE)

PLACE SWITCH ASSEMBLY ON LOWER SURFACE OF MAIN CASTING. EXERCISE CARE IN SEATING SLIDE LEVERS AGAINST PUSHER LEVERS AND LATCH LEVERS IN APPROPRIATE SLOT OF SLIDE LEVER GUIDE.

STORING SWITCH ASSEMBLY

REQUIREMENT

WITH TOP PLATE IN PLACE, SELECT A LETTERS - BLANK - LETTERS COMBINATION AND OBSERVE LATCH AND PUSHER LEVER ACTION. STORING SWITCH SHOULD ALIGN WITH LATCH LEVER SO THAT LATCH LEVERS AND SLIDES FUNCTION WITHOUT BINDING.

TO ADJUST

POSITION SWITCH ASSEMBLY WITH ITS MOUNTING SCREWS LOOSENED. RECHECK REQUIREMENT AFTER TIGHTENING SCREWS.

NOTE

A MINOR ADJUSTMENT OF THE SENSING PIN AND PUSHER LEVER GUIDE MAY BE NECESSARY.

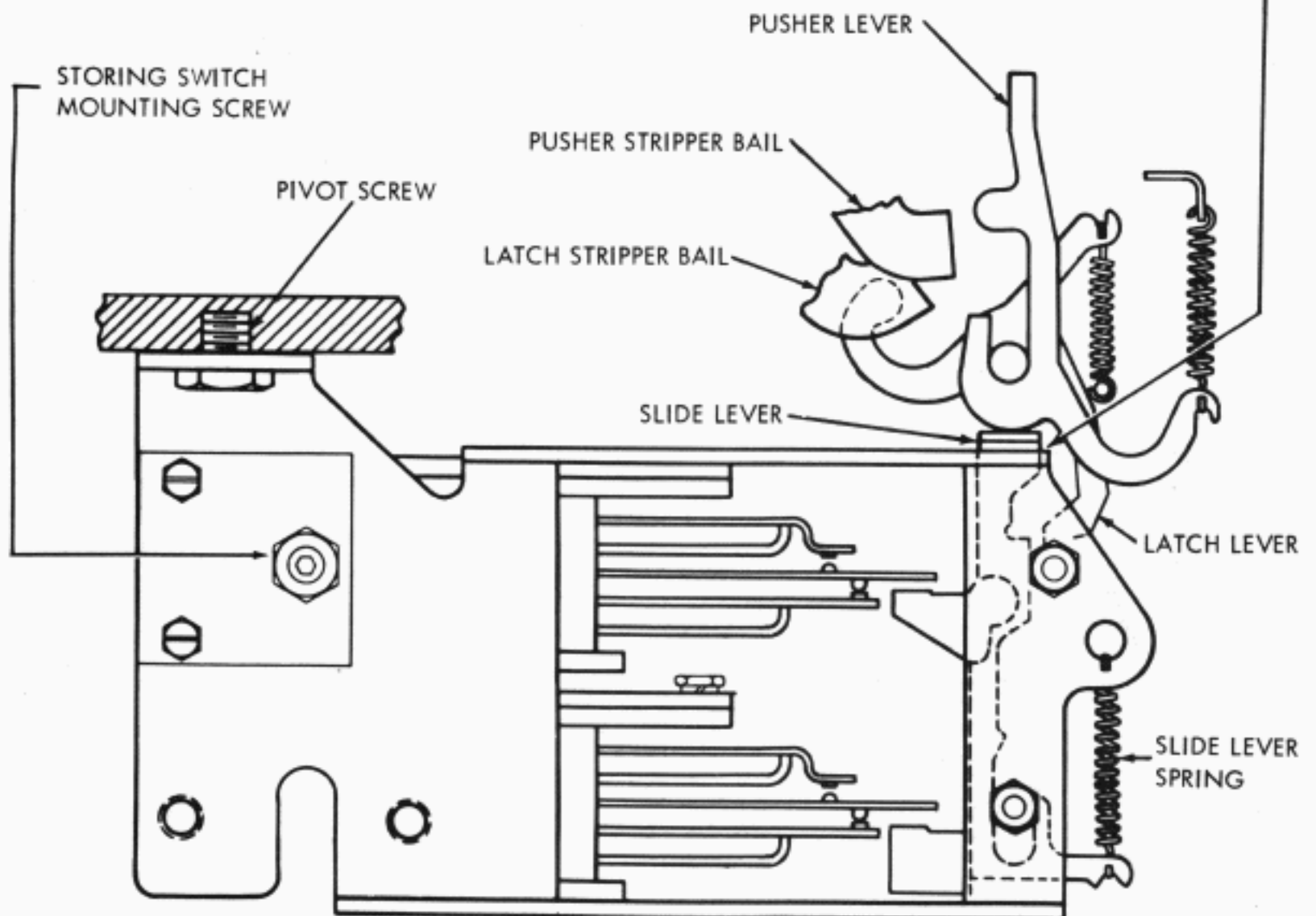

FIGURE 1-14. TRANSFER TYPE STORING SWITCH MECHANISM

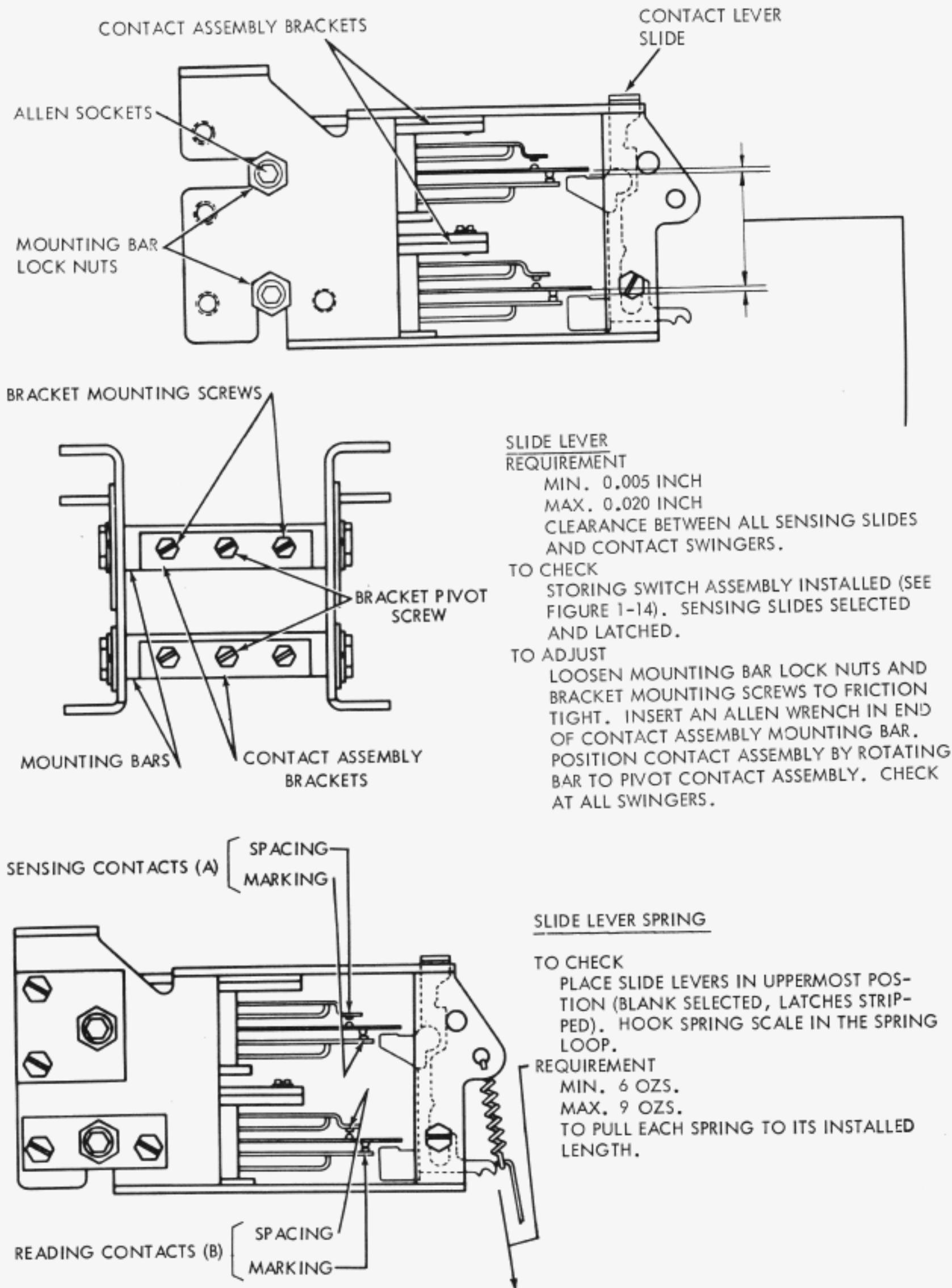

FIGURE 1-15. TRANSFER TYPE STORING SWITCH MECHANISM

TAPE LID - LATE DESIGN (SEE FIGURE 1-41 FOR EARLY DESIGN)

NOTE

REMOVE TOP AND TAPE GUIDE PLATES. LUBRICATE MATING SURFACES PRIOR TO ADJUSTMENT.

- (1) REQUIREMENT
 MIN. SOME
 MAX. 0.010 INCH
 CLEARANCE BETWEEN PIVOT SHOULDER AND TAPE LID WHEN LID IS PRESSED AGAINST NOTCH IN TAPE GUIDE PLATE, AND FEED WHEEL SLOTS AND TAPE-OUT PIN HOLES ARE LINED UP.
 TO ADJUST
 LOOSEN TAPE LID BRACKET MOUNTING NUTS. USING A 156743 GAUGE, LINE UP FEED WHEEL GROOVE IN TAPE LID WITH SLOT IN TAPE GUIDE PLATE. POSITION TAPE LID BRACKET TO MEET REQUIREMENT.
- (2) REQUIREMENT - (SEE FIGURE 1-17).

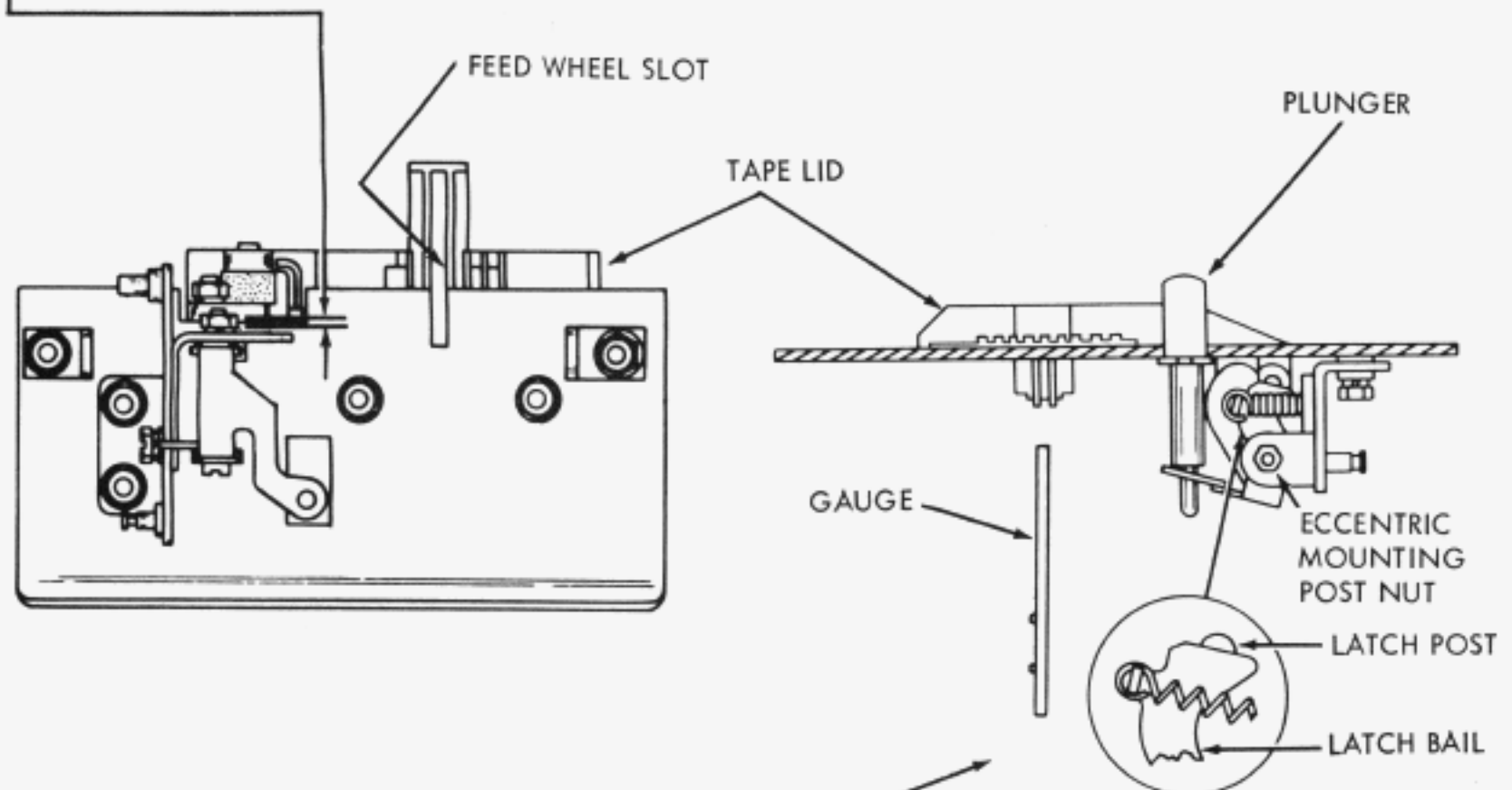

- (3) REQUIREMENT
 SOME END PLAY IN RELEASE PLUNGER WHEN LID IS LATCHED AGAINST TAPE GUIDE PLATE
 TO ADJUST
 WITH ECCENTRIC MOUNTING POST NUT FRICTION TIGHT AND TAPE LID RAISED, ROTATE HIGH PART OF ECCENTRIC POST TOWARDS MOUNTING BRACKET. CLOSE TAPE LID. ROTATE ECCENTRIC COUNTERCLOCKWISE (AS VIEWED FROM SLOTTED END OF ECCENTRIC POST) UNTIL FLAT OF LATCH POST FULLY ENGAGES LATCH BAIL FLAT. ROTATE ECCENTRIC CLOCKWISE TO TAKE UP ALL PLAY IN PARTS, AND TO SEAT OPEN END OF TAPE LID AGAINST TAPE GUIDE PLATE.
 TO CHECK
 WITH TAPE LID HELD DOWN MANUALLY, LATCH TIP SHOULD CLEAR LATCH POST WHEN RELEASE BUTTON IS OPERATED. WITH TAPE LID LATCHED, TIP OF LATCH SHOULD PROJECT BEYOND FLAT OF LATCH POST, AND THERE SHOULD BE SOME END PLAY IN RELEASE BUTTON.

FIGURE 1-16. TAPE LID MECHANISM

(2) REQUIREMENT

WITH TAPE LID FRONT BEARING SURFACE TOUCHING TAPE GUIDE PLATE, CLEARANCE BETWEEN TAPE LID AND TAPE GUIDE PLATE:

MIN. 0.010 INCH

MAX. 0.018 INCH

MEASURED AT TAPE LID FIN IN LINE WITH REAR TAPE GUIDE. 2ND. FIN FROM REAR

NOTE

WHEN BOTH TOP AND TAPE GUIDE PLATES ARE ASSEMBLED ON UNIT, LEFT EDGE OF LID MAY TOUCH TOP PLATE AND SOME CHANGE IN THIS CLEARANCE MAY BE EXPECTED.

TO ADJUST

WITH TAPE LID BEARING BRACKET MOUNTING SCREWS FRICTION TIGHT, AND TAPE LID PRESSED AGAINST TAPE GUIDE PLATE, POSITION BEARING BRACKET. RECHECK REQUIREMENT (1).

(1) AND (3) REQUIREMENTS - (SEE FIGURE 1-16).

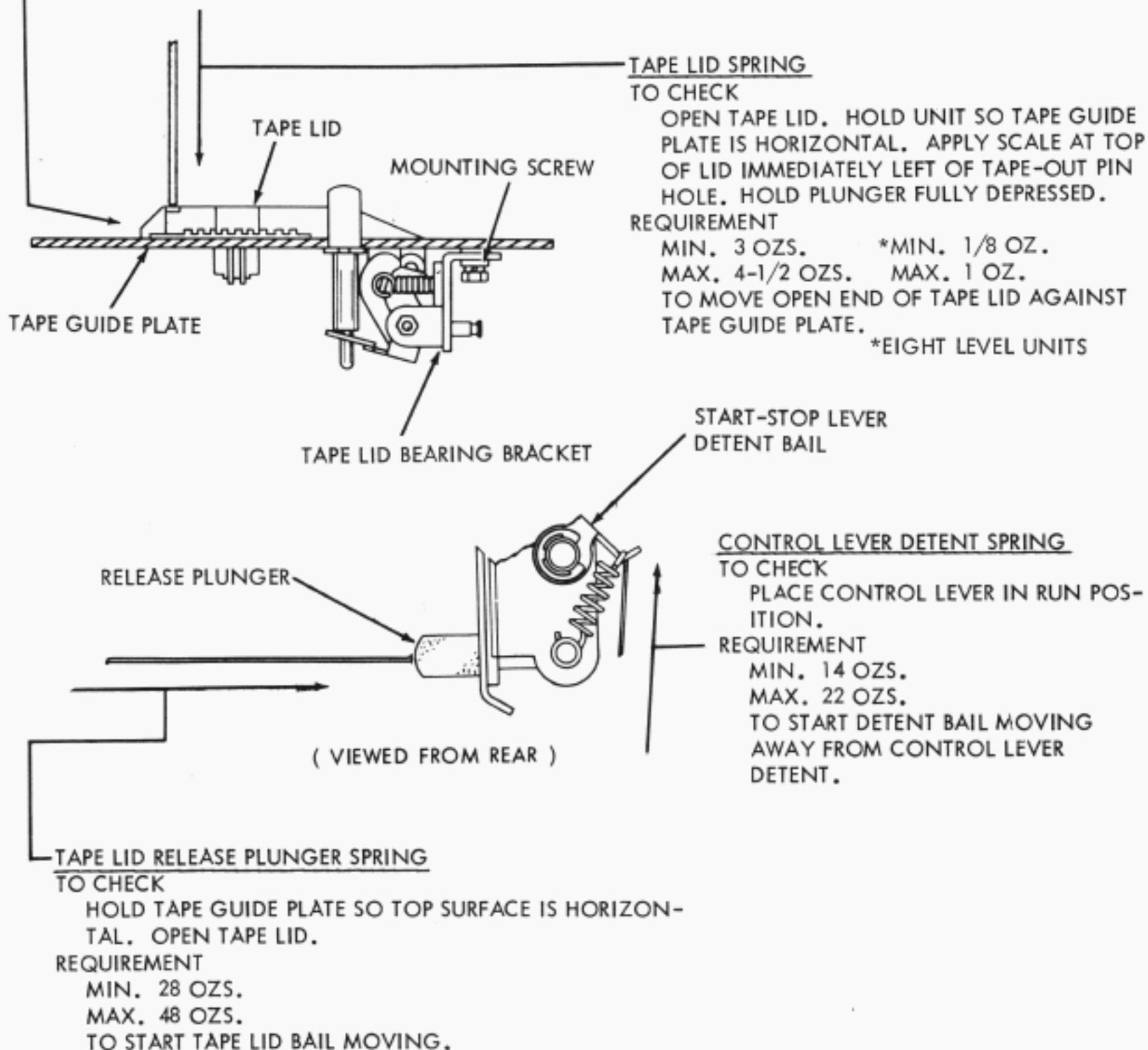
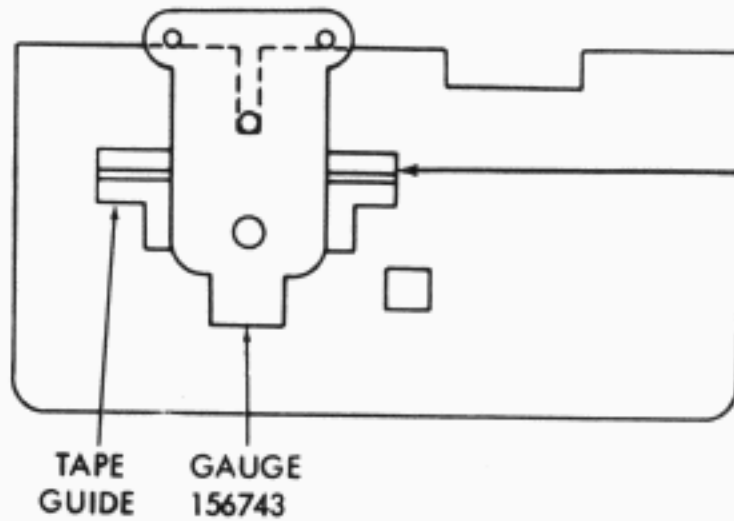

FIGURE 1-17. TAPE LID MECHANISM



**TAPE GUIDE
REQUIREMENT**

WITH GAUGE PROPERLY POSITIONED:
MIN. SOME
MAX. 0.003 INCH
BETWEEN GAUGE AND TAPE GUIDES

TO ADJUST

LOOSEN TAPE GUIDE MOUNTING NUTS TO FRICTION TIGHT. PROPERLY POSITION GAUGE ON TAPE GUIDE PLATE. POSITION TAPE GUIDES TO MEET REQUIREMENT.

TAPE GUIDE PLATE

(1) REQUIREMENT

SHOULDER OF FEED WHEEL POST SHOULD NOT INTERFERE WITH TOP PLATE OR TAPE GUIDE PLATE MOUNTING BRACKETS.

TO ADJUST

ROTATE FEED WHEEL POST WITH ITS MOUNTING NUT LOOSENED.

(2) REQUIREMENT

TAPE GUIDE PLATE SHOULD REST FIRMLY AGAINST AT LEAST THREE PROJECTIONS OF THE FRONT AND REAR PLATE.

TO ADJUST

WITH TAPE-OUT DOWNSTOP IN ITS LOWERMOST POSITION, AND TAPE GUIDE PLATE MOUNTING BRACKET (FRONT AND REAR) NUTS FRICTION TIGHT, TRIP CLUTCH AND ROTATE SHAFT UNTIL SENSING PINS ARE IN THEIR UPPERMOST POSITION. WITH TAPE LID RAISED AND CONTROL LEVER IN RUN POSITION, PRESS TAPE GUIDE PLATE INTO POSITION. GUIDE MOUNTING SCREWS INTO NOTCH OF FRONT AND REAR PLATE, AND PLACE SENSING PINS ADJACENT TO LEFT EDGE OF GUIDE PLATE. PLACE TAPE-OUT PIN INTO ITS HOLE. TIGHTEN EACH BRACKET MOUNTING.

(3) REQUIREMENT

OUTER EDGES OF MOUNTING BRACKETS AND OUTER EDGES OF MOUNTING STUD SHOULDERS SHOULD ALIGN AND PROJECT EQUALLY ON FRONT AND REAR BRACKETS.

TO ADJUST

MOVE TAPE GUIDE PLATE TOWARD FRONT OR REAR. TIGHTEN NUTS ONLY AFTER TOP PLATE IS ADJUSTED (SEE FIGURE 1-19).

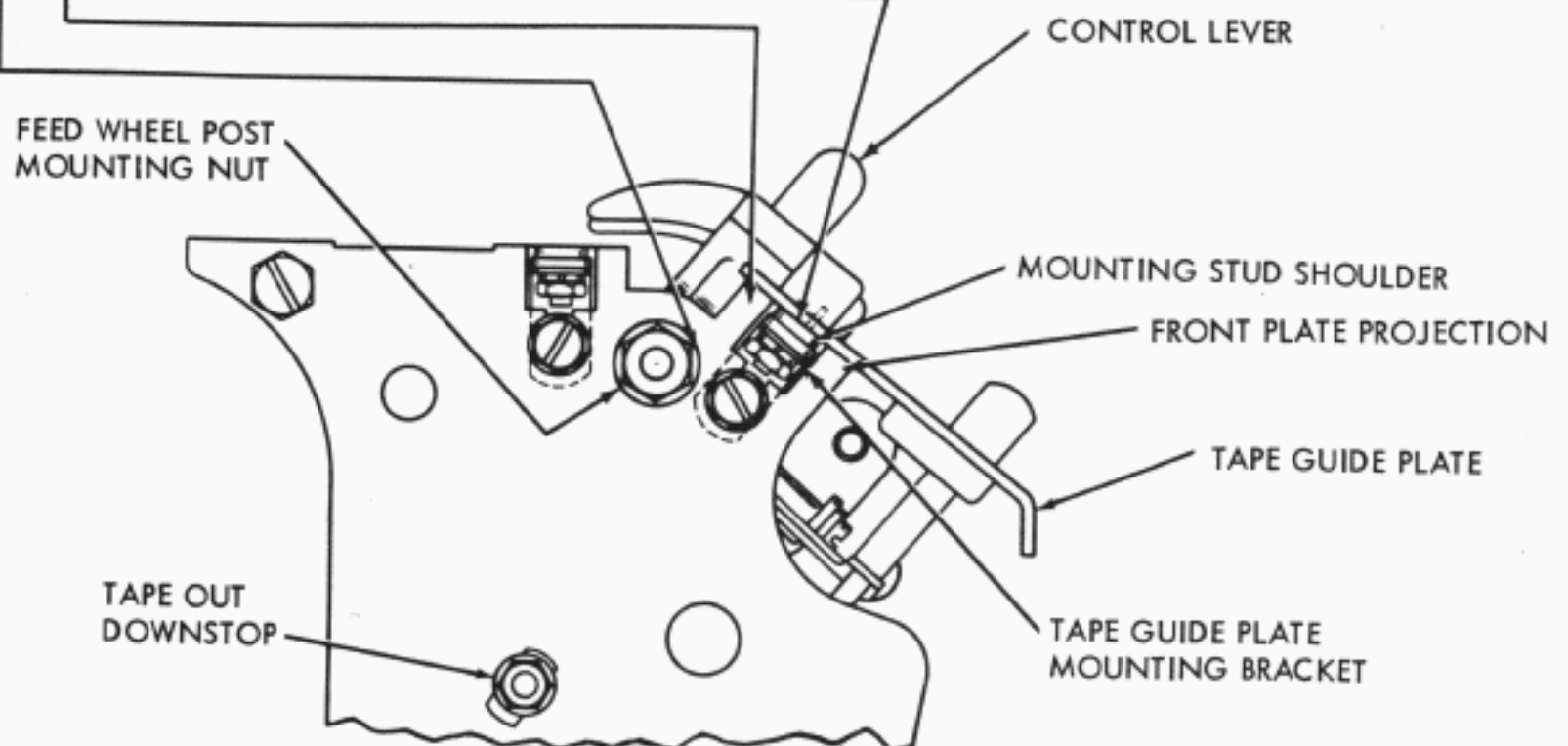

FIGURE 1-18. TAPE GUIDE PLATE

TOP PLATE

(1) REQUIREMENT

TOP PLATE FLUSH TO 0.003 INCH UNDER FLUSH WITH TAPE GUIDE PLATE WITHIN WIDTH OF TAPE LID.

TO ADJUST

LOOSEN MOUNTING BRACKET NUTS UNTIL BRACKETS ARE FRICTION TIGHT. PRESS TOP PLATE INTO POSITION. TOP PLATE SHOULD REST ON AT LEAST THREE PROJECTIONS OF SIDE PLATES. MAKE SURE THE TIGHT-TAPE ARM EXTENSION IS UNDER THE TOP PLATE.

(2) REQUIREMENT

FEED WHEEL SLOT AND TAPE GUIDE PLATE SLOT SHOULD LINE UP

TO ADJUST

MOVE TOP PLATE TO LINE UP FEED WHEEL SLOT. DO NOT DISTURB REQUIREMENT (2) OF TAPE GUIDE PLATE ADJUSTMENT (SEE FIGURE 1-18).

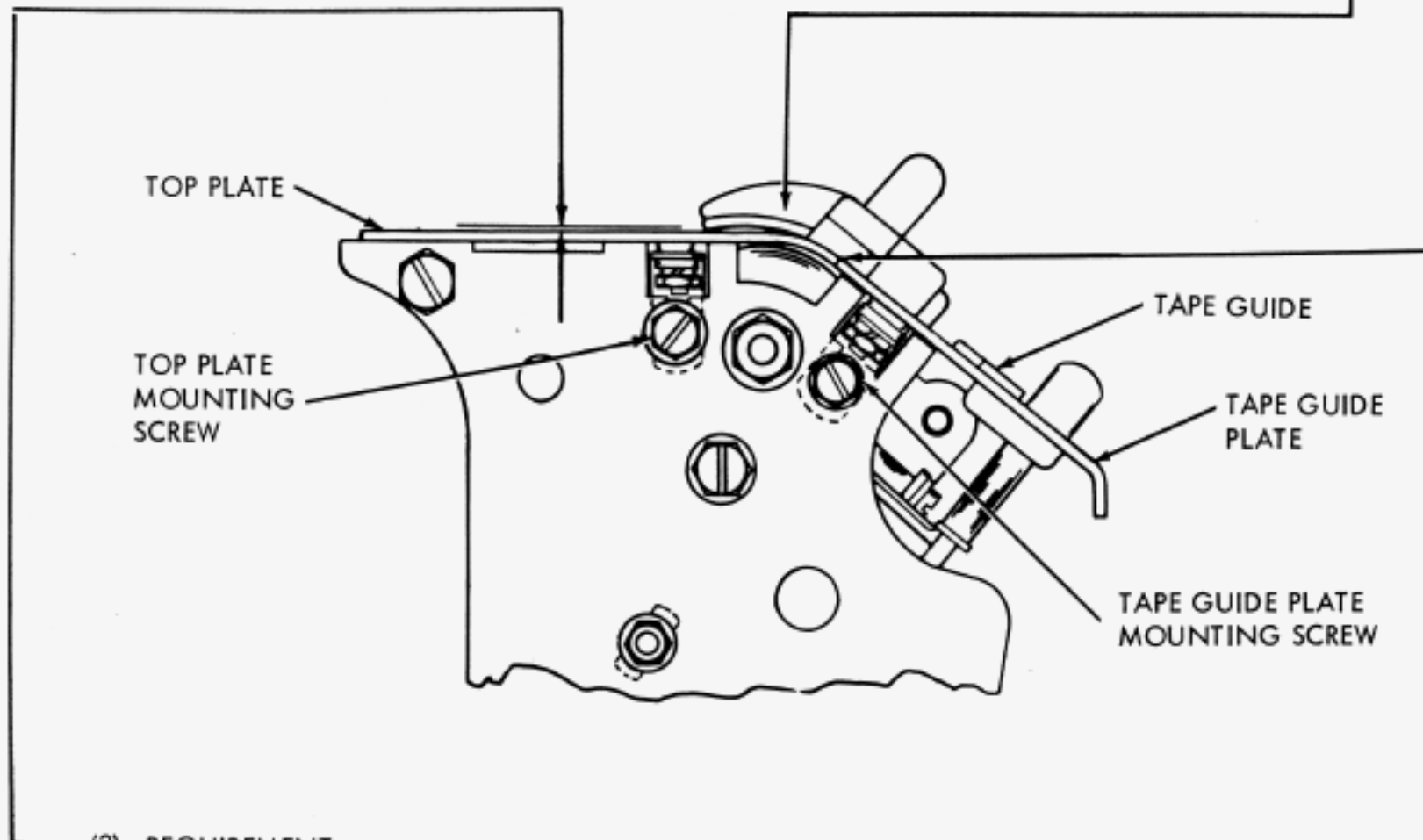

(3) REQUIREMENT

WITH TAPE LID LATCHED, CLEARANCE BETWEEN TAPE LID EXTENSION COVERING FEED WHEEL SLOT, AND TOP PLATE:

MIN. 0.010 INCH

MAX. 0.020 INCH

MEASURED AT CURVED PORTION OF TOP PLATE, AND

MIN. 0.010 INCH

MAX. 0.025 INCH

MEASURED AT FLAT PORTION OF TOP PLATE.

ALSO:

MIN. 0.010 INCH

MAX. 0.018 INCH

CLEARANCE BETWEEN TAPE LID AND TAPE GUIDE PLATE MEASURED IN AREA BETWEEN TAPE GUIDES (PLAY IN TAPE LID TAKEN TOWARD TAPE GUIDE PLATE).

TO ADJUST

LOOSEN TWO SCREWS HOLDING TAPE LID MOUNTING BRACKETS TOGETHER, AND POSITION TAPE LID. RECHECK ADJUSTMENTS (1) AND (2) OF TAPE LID ADJUSTMENT (SEE FIGURE 1-16).

FIGURE 1-19. TOP PLATE ASSEMBLY

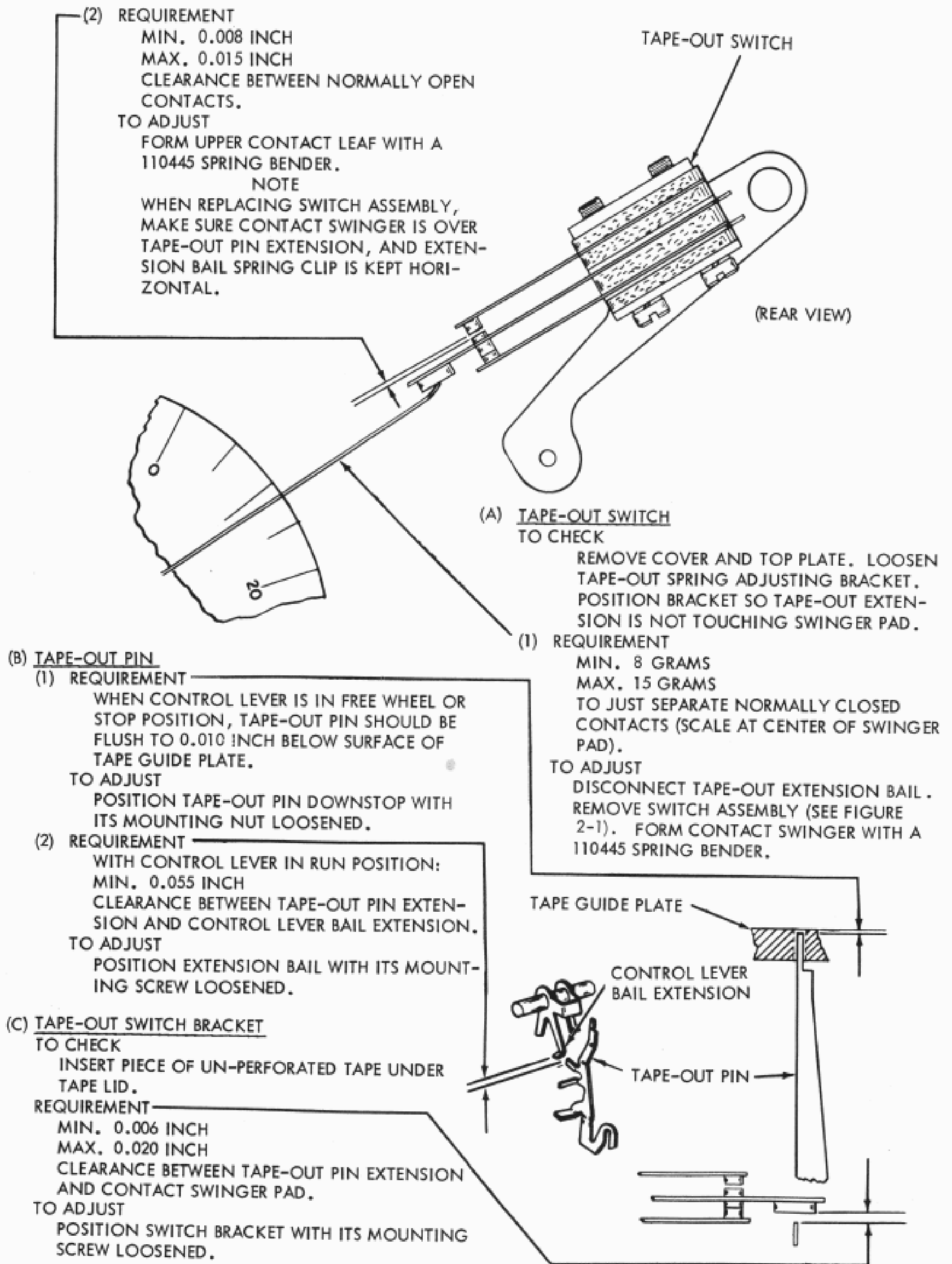

FIGURE 1-20. TAPE-OUT SWITCH ASSEMBLY

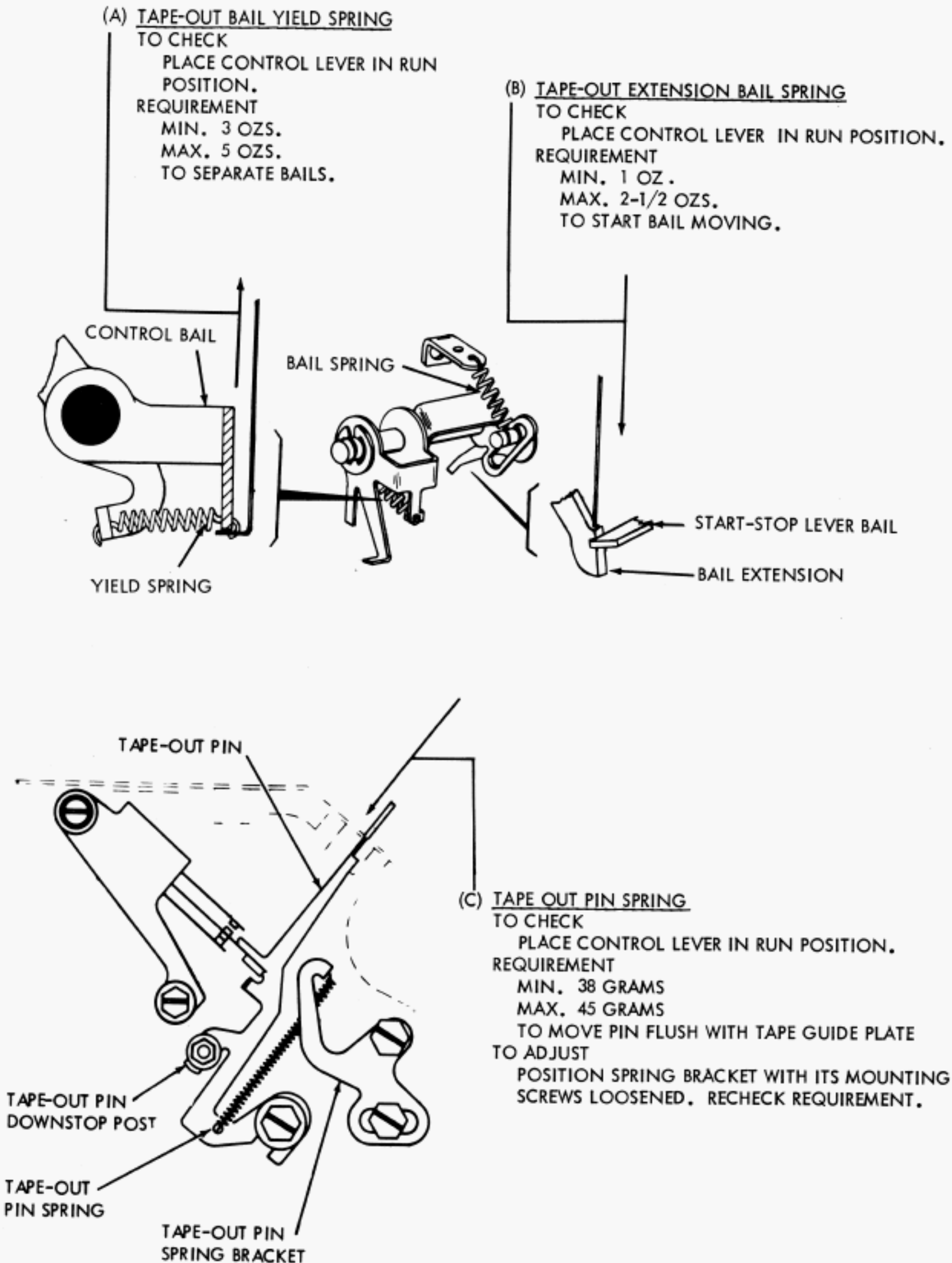
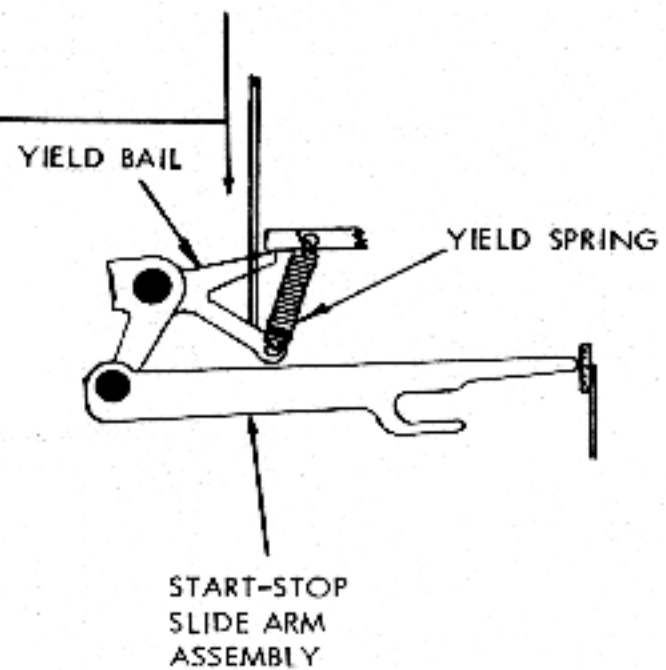

FIGURE 1-21. TAPE-OUT PIN AND BAIL ASSEMBLY

START-STOP BAIL YIELD SPRING
TO CHECK

PLACE CONTROL LEVER IN RUN
POSITION
REQUIREMENT
MIN. 4 OZS.
MAX. 6 OZS.
TO SEPARATE BAILS.



CONTROL LEVER SWITCH BRACKET

- (1) REQUIREMENT
WITH CONTROL LEVER IN RUN POSITION:
MIN. 0.005 INCH
MAX. 0.015 INCH
CLEARANCE BETWEEN SWITCH ACTUATOR
AND BAKELITE PAD ON SWINGER.
- (2) REQUIREMENT
START-STOP AND TIGHT TAPE SWITCH ACT-
UATORS SHOULD FULLY ENGAGE BAKELITE
PAD ON SWINGER.
- TO ADJUST
POSITION SWITCH BRACKET WITH ITS
MOUNTING SCREWS LOOSENED.
- NOTE
IF TIGHT TAPE SWITCH ACTUATOR RESTS
AGAINST BAKELITE PAD, HOLD ACTUATOR
AWAY.

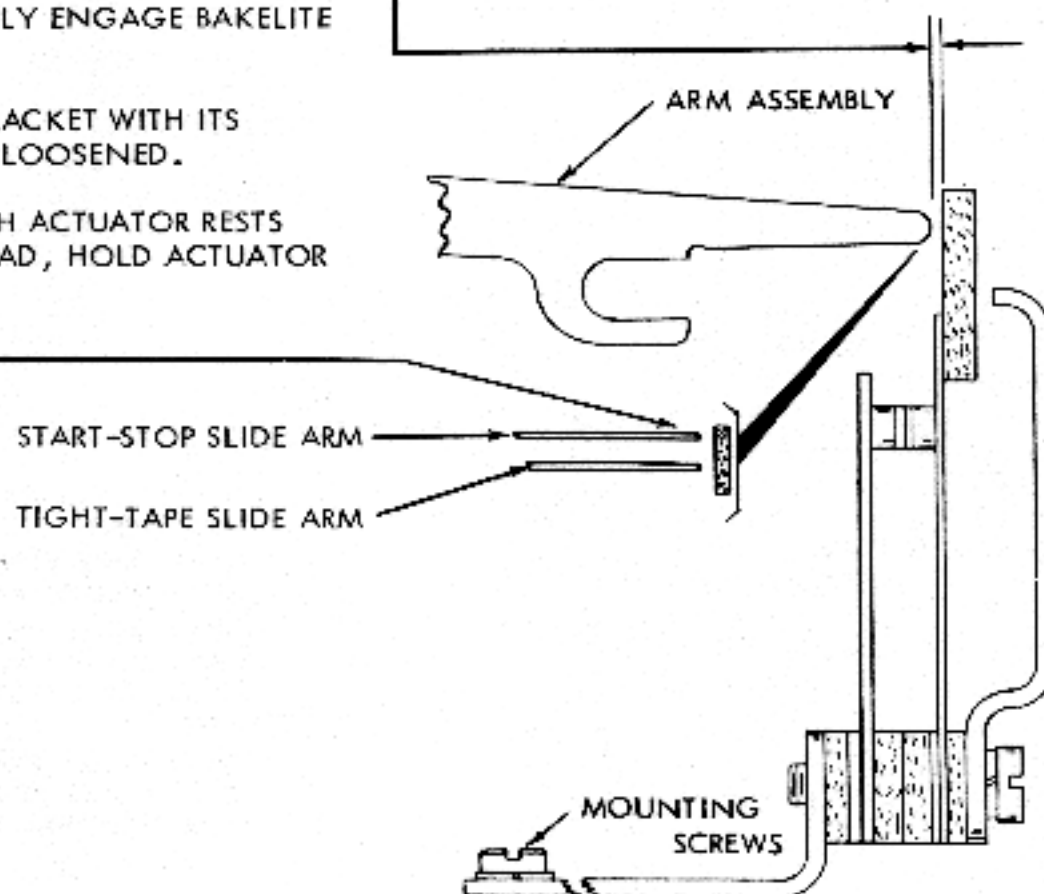

FIGURE 1-22. START-STOP SWITCH ASSEMBLY

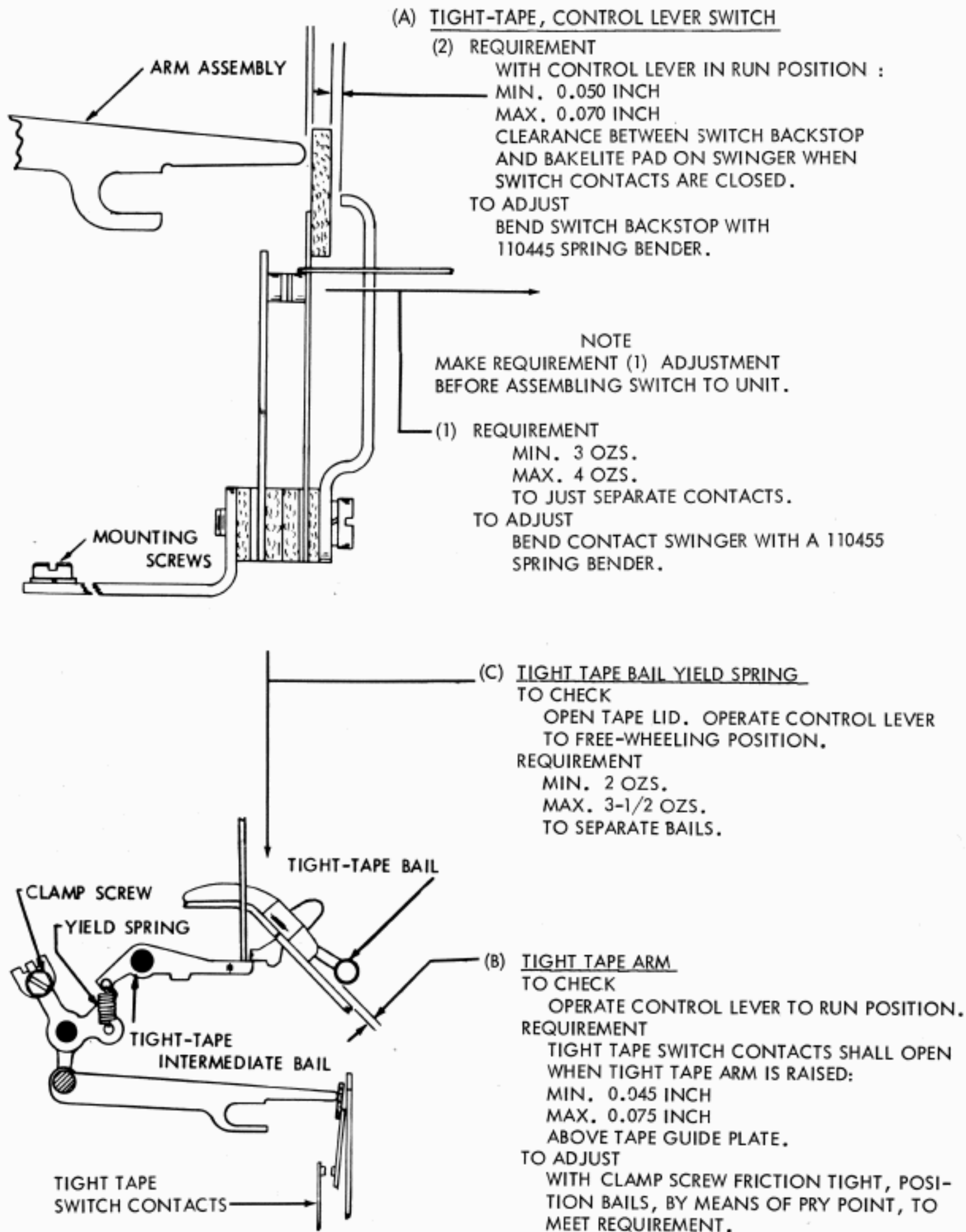

FIGURE 1-23. TIGHT TAPE MECHANISM

(A) SENSING BAIL SPRINGS
TO CHECK

REMOVE TOP PLATE. WITH BLANK TAPE UNDER TAPE LID, TRIP CLUTCH MAGNET AND MANUALLY ROTATE SHAFT UNTIL SENSING BAIL IS IN UPPERMOST POSITION. APPLY SCALE TO BAIL BETWEEN SPRINGS.
REQUIREMENT
MIN. 1/4 OZ.
MAX. 2 OZS.
TO START BAIL MOVING.

(C) SENSING PIN
TO CHECK

REPLACE TOP PLATE. DISENGAGE SENSING CLUTCH.
REQUIREMENT
WITH SENSING BAIL ECCENTRIC INDENT TOWARD RIGHT, TIP ON HIGHEST SENSING PIN SHALL BE FLUSH TO 0.005 INCH BELOW TOP SURFACE OF TAPE GUIDE PLATE.
TO ADJUST
LOOSEN ECCENTRIC SHAFT LOCK NUT AND POSITION ECCENTRIC. RECHECK REQUIREMENT AFTER LOCK NUT IS TIGHTENED.

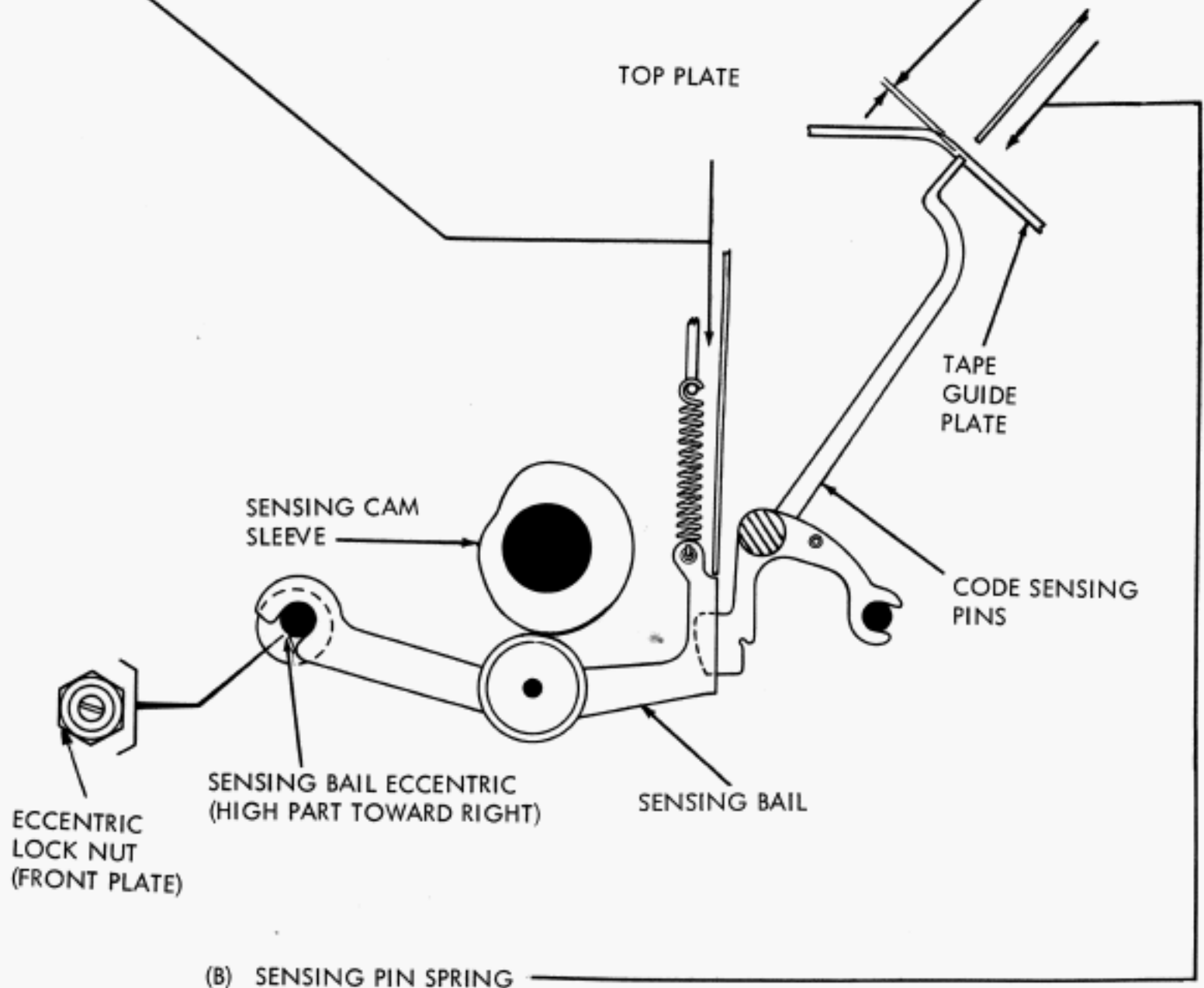

(B) SENSING PIN SPRING
TO CHECK

TRIP SENSING CLUTCH AND ROTATE SHAFT UNTIL SENSING PINS ARE IN THEIR UPPERMOST POSITION. HOLD PUSHER LEVERS AWAY MANUALLY.
REQUIREMENT
MIN. 2 OZS.
MAX. 3 OZS.
TO MOVE EACH PIN FLUSH WITH TOP SURFACE OF TAPE GUIDE PLATE.

FIGURE 1-24. SENSING PIN ASSEMBLY

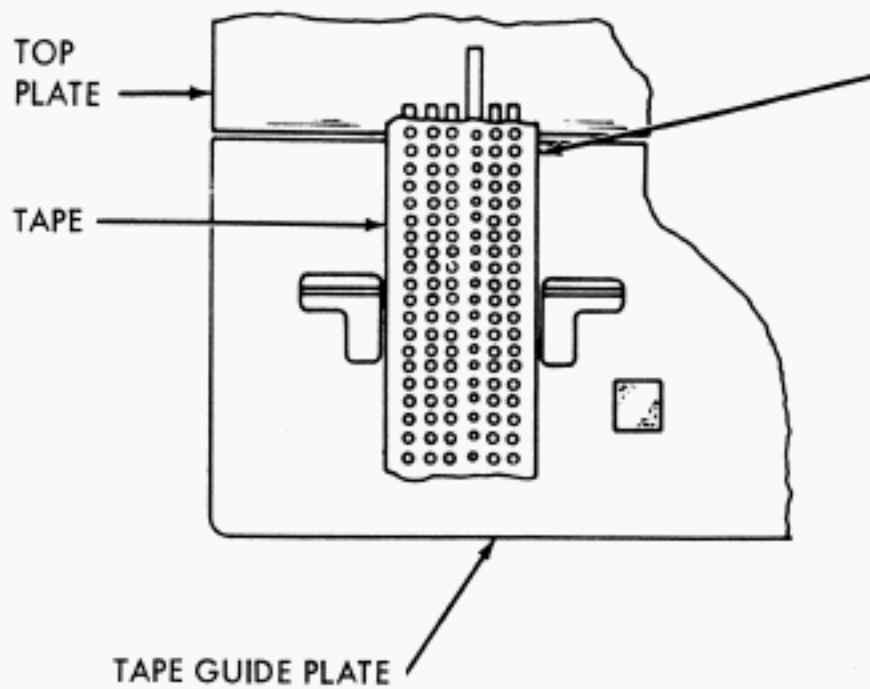
(A) FEED WHEEL DETENT

NOTE

PLACE CONTROL LEVER IN STOP POSITION. IF UNIT HAS A SPRING BIASED CONTROL LEVER, MAKE ADJUSTMENT WITH LEVER IN RUN POSITION.

TO CHECK

PLACE A "LETTERS" PERFORATED TAPE OVER FEED WHEEL, TAKING UP PLAY IN FEED HOLES TOWARD THE RIGHT.

REQUIREMENT

SENSING PINS CENTRALLY LOCATED IN CODE HOLES.

TO ADJUST

POSITION FEED WHEEL DETENT ECCENTRIC WITH ITS LOCK SCREW FRICTION TIGHT. HIGH PART OF ECCENTRIC SHOULD BE TOWARD RIGHT. HOLD ECCENTRIC AND TIGHTEN GUIDE POST AND LOCK SCREW. RECHECK ADJUSTMENT.

NOTE

HOLD FEED PAWL AWAY TO FACILITATE ADJUSTMENT.

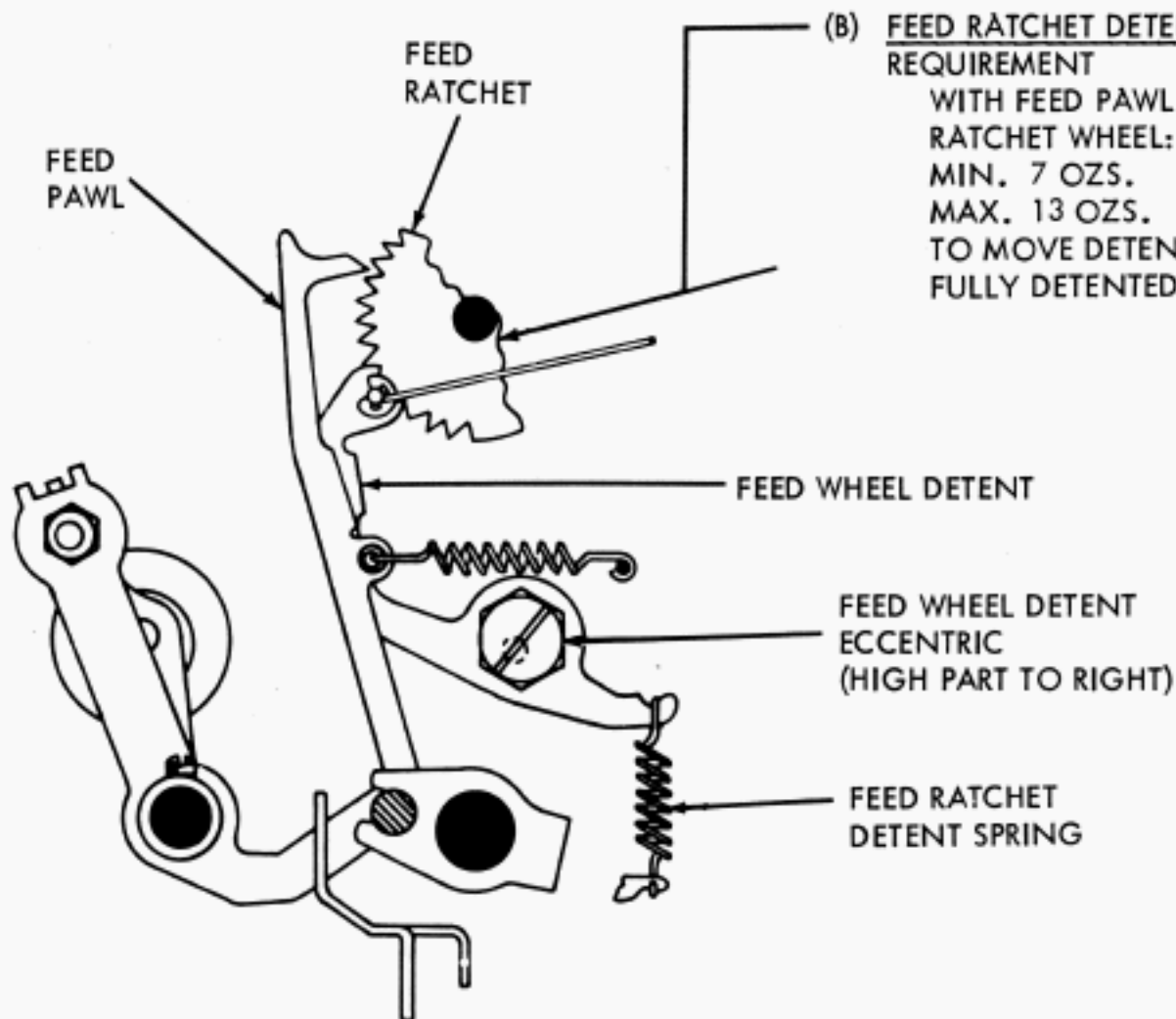
(B) FEED RATCHET DETENT SPRING

REQUIREMENT

WITH FEED PAWL HELD AWAY FROM RATCHET WHEEL:

MIN. 7 OZS.

MAX. 13 OZS.

TO MOVE DETENT ROLLER AWAY FROM FULLY DETENTED POSITION.

FIGURE 1-25. TAPE FEED MECHANISM

- (B) FEED PAWL SPRING
 TO CHECK
 PLACE CONTROL LEVER IN STOP POSITION.
 REMOVE TOP PLATE. DISENGAGE CLUTCH.
 REQUIREMENT
 MIN. 1/4 OZ.
 MAX. 1-1/2 OZS.
 TO START FEED PAWL MOVING.

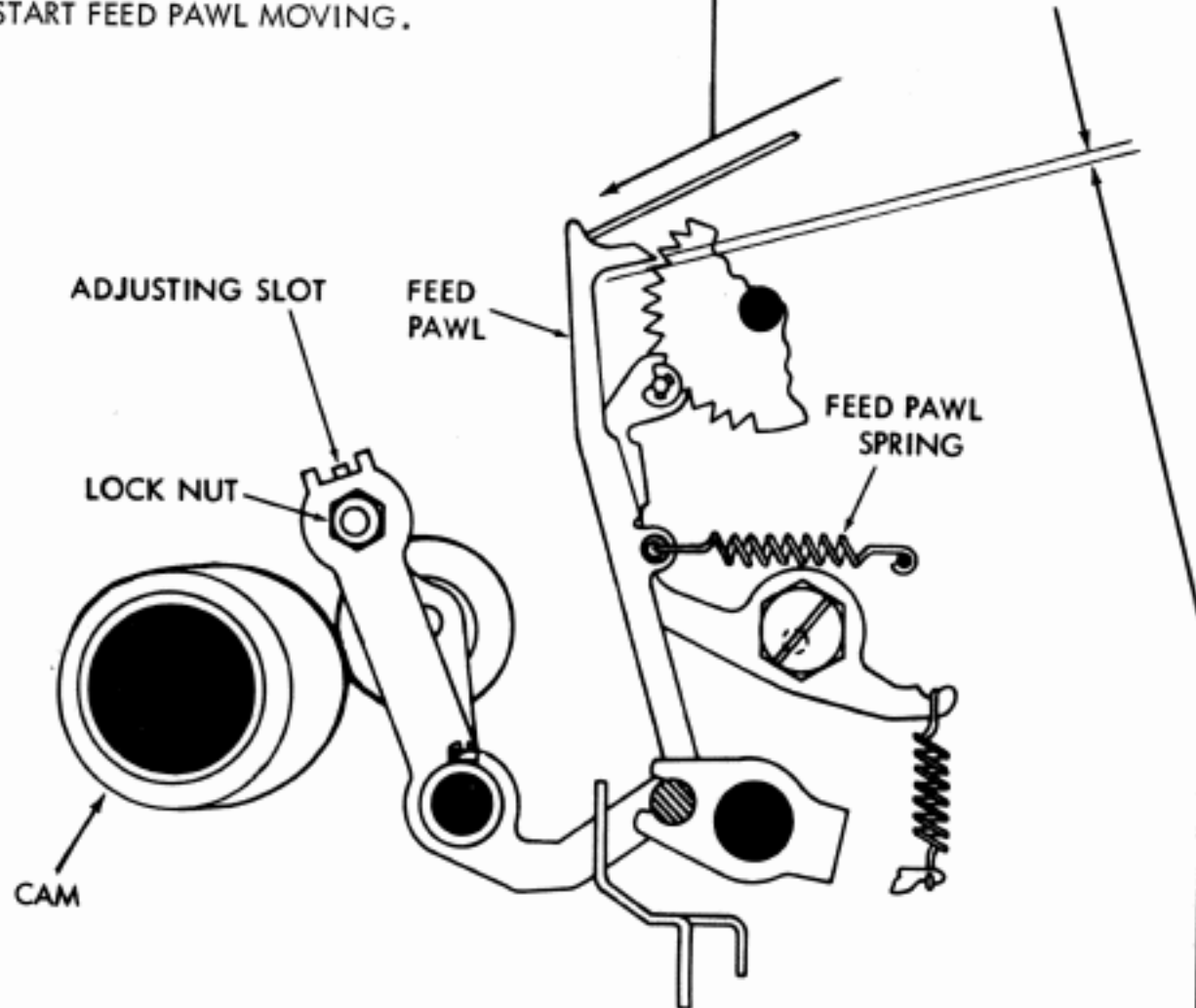

- (A) FEED PAWL
 TO CHECK
 PLACE CONTROL LEVER IN RUN POSITION.
 REMOVE TOP PLATE. TRIP CLUTCH, AND ROTATE CAM
 SHAFT UNTIL FEED ROLLER IS ON HIGH PART OF CAM.
 ROTATE RATCHET WHEEL UNTIL OIL HOLE IS UP. TAKE
 UP PLAY BY PRESSING DOWN LIGHTLY ON RIGHT END
 OF FEED PAWL BAIL.
 REQUIREMENT
 MIN. SOME
 MAX. 0.003 INCH
 CLEARANCE BETWEEN FEED PAWL AND RATCHET TOOTH.
 TO ADJUST
 POSITION FEED LEVER BY MEANS OF THE ADJUSTING
 SLOT WITH ITS LOCK NUT LOOSENED.

FIGURE 1-26. TAPE FEED MECHANISM

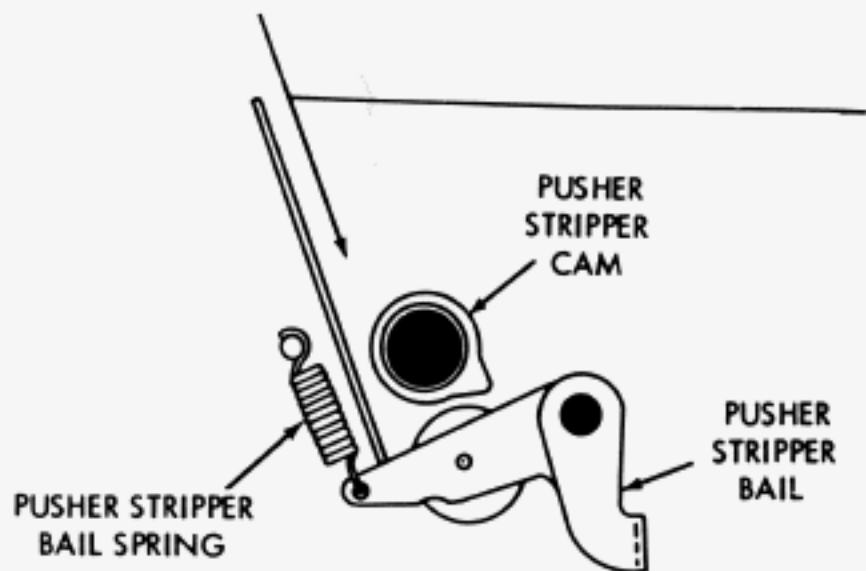

- (A) PUSHER STRIPPER BAIL SPRING
 TO CHECK
 SELECT BLANK COMBINATION. TRIP CLUTCH AND ROTATE SHAFT TO STOP POSITION.
 REQUIREMENT
 MIN. 7 OZS.
 MAX. 11 OZS.
 TO START BAIL MOVING AWAY FROM CAM.

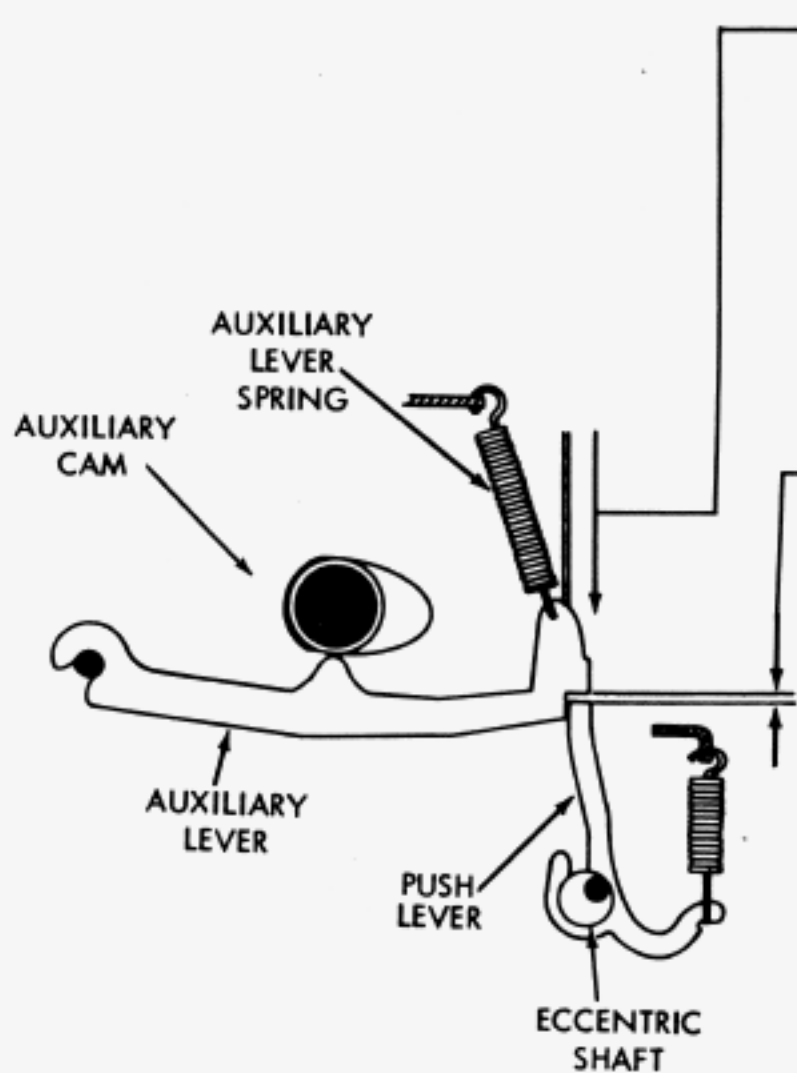

- (C) AUXILIARY LEVER SPRING
 TO CHECK
 EACH AUXILIARY LEVER ON LOW PART OF ITS CAM. SCALE APPLIED TO LEVER JUST RIGHT OF SPRING. PUSHER LEVER HELD AWAY.
 REQUIREMENT
 MIN. 1/2 OZ.
 MAX. 3 OZS.
 TO START AUXILIARY LEVER MOVING.

- (B) PUSH LEVER
 REQUIREMENT
 WITH FIRST ONE AND THEN THE OTHER OF THE TWO AUXILIARY LEVERS ON THE LOW PART OF THE CAM, THE AUXILIARY LEVER WITH THE LEAST CLEARANCE SHOULD CLEAR THE TIP OF ITS PUSH LEVER BY
 MIN. 0.020 INCH
 MAX. 0.045 INCH
 TO ADJUST
 WITH PUSH LEVER ECCENTRIC SHAFT LOCK NUT (FRONT PLATE) LOOSENED AND HIGH PART OF ECCENTRIC LOCATED TOWARD THE UPPER RIGHT, ROTATE ECCENTRIC TOWARD RIGHT OR LEFT.

FIGURE 1-27. SENSING MECHANISM

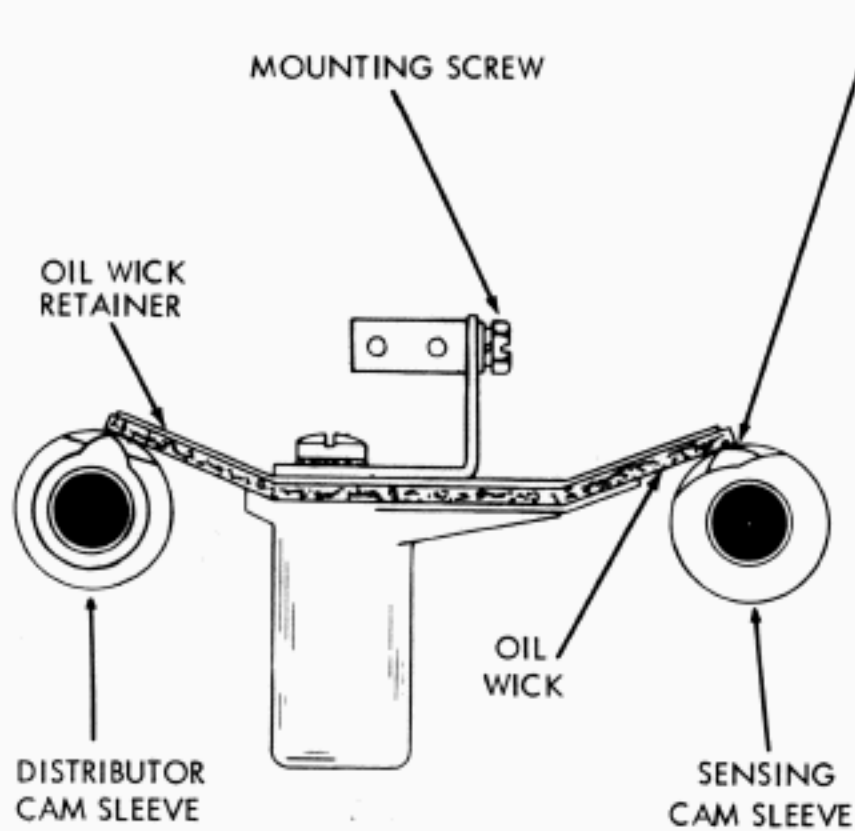
**(B) OIL RESERVOIR****REQUIREMENT**

EACH OIL WICK RESTS LIGHTLY ON HIGH PARTS OF FRONT AND REAR CAM OF EACH CAM SLEEVE.

TO ADJUST

TRIP BOTH ARMATURES AND ROTATE SHAFT UNTIL HIGH PART OF FRONT AND REAR CAM OF EACH SLEEVE IS UNDER ITS WICK. POSITION OIL RESERVOIR ASSEMBLY WITH ITS MOUNTING SCREWS (4) LOOSENED. WHEN CAM SLEEVE IS ROTATED, TEETH OF WICK RETAINER SHOULD NOT DEFLECT UPWARD MORE THAN 1/32 INCH (GAUGE BY EYE). REFINE ADJUSTMENT BY SLIGHTLY BENDING TEETH ON WICK COMB SPRING.

**(A) LATCH STRIPPER BAIL SPRING****TO CHECK**

TRIP CLUTCH, ROTATE SHAFT SO LATCH BAIL FOLLOWER ROLLER IS ON LOW PART OF CAM. APPLY SCALE TO TOP OF LATCH STRIPPER BAIL.

REQUIREMENT

MIN. 2-3/4 OZS.

MAX. 6 OZS.

TO START LATCH STRIPPER BAIL MOVING.

FIGURE 1-28. SENSING MECHANISM SPRINGS

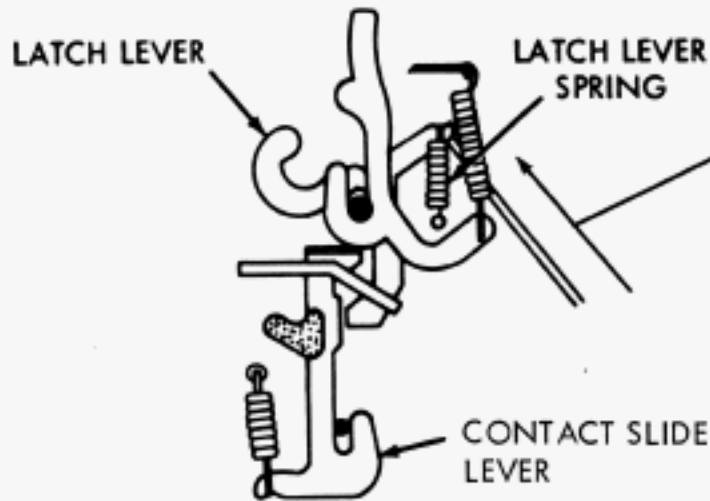

(C) LATCH LEVER SPRING
TO CHECK

SELECT BLANK COMBINATION, TRIP SENSING CLUTCH AND ROTATE SHAFT TO STOP POSITION. SLIDE LEVERS SHOULD BE IN UPPERMOST POSITION.

REQUIREMENT

MIN. 1 OZ.
MAX. 3 OZS.
TO START LATCH LEVER MOVING.

NOTE

TAKE CARE NOT TO DAMAGE PUSH LEVER SPRINGS IN CHECKING REQUIREMENT.

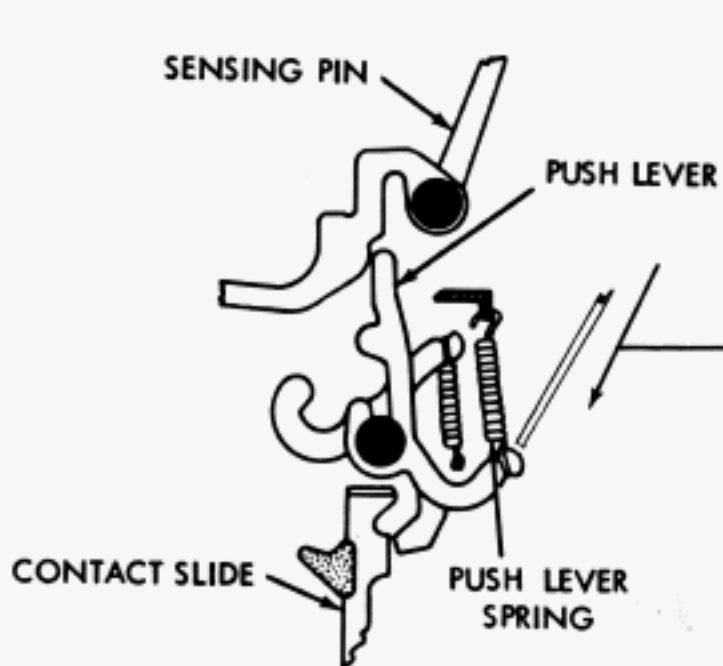

(B) PUSH LEVER SPRING
TO CHECK

SELECT "LETTERS" COMBINATION, AND LATCH SENSING CLUTCH. TRIP CLUTCH AND ROTATE SHAFT UNTIL PUSH LEVERS ARE STRIPPED.

REQUIREMENT

MIN. 1/4 OZ.
MAX. 1-1/2 OZS.
TO START PUSH LEVER MOVING.

NOTE

BE SURE CONTACT SLIDES DO NOT INTERFERE WITH MOVEMENT OF PUSH LEVERS.

FIGURE 1-29. SENSING MECHANISM SPRINGS

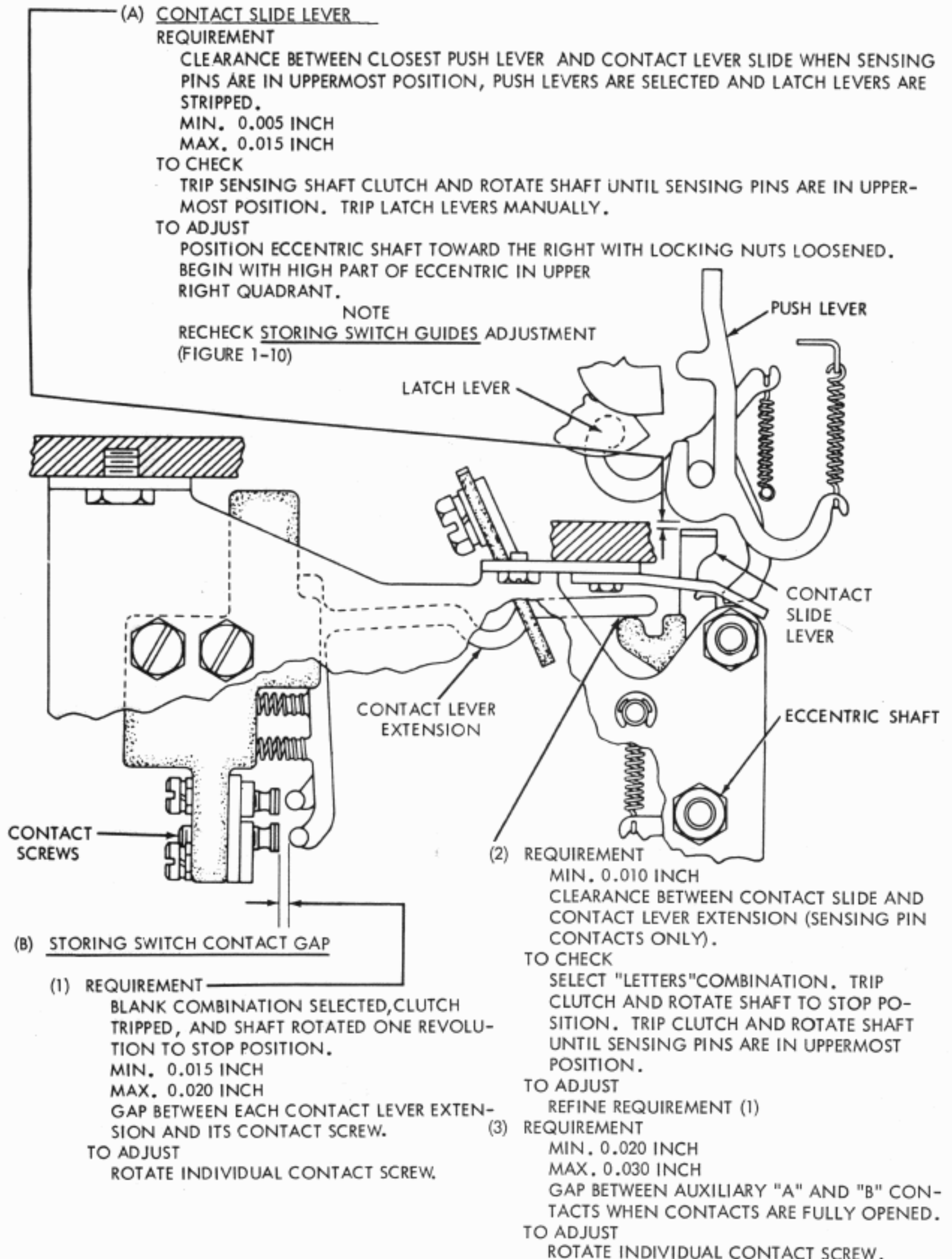

FIGURE 1-30. STORING SWITCH MECHANISM

(A) COVER PLATE

(1) REQUIREMENT

COVER PLATE HELD FLUSH AGAINST TOP PLATE BY DETENT ACTION.

(2) REQUIREMENT

COVER PLATE RESTS ON AT LEAST THREE SIDE FRAME PROJECTIONS.

(3) REQUIREMENT

FRONT EDGE OF COVER AND TOP PLATES IN LINE.

TO ADJUST

LOOSEN DETENT NUTS ON SIDE FRAMES, AND MOVE THEM TO EXTREME LOWER RIGHT POSITION. TIGHTEN NUTS. LOOSEN FOUR BRACKET MOUNTING NUTS ON COVER PLATE. PLACE COVER INTO POSITION, AND POSITION TO MEET REQUIREMENTS. TIGHTEN NUTS. RECHECK AND REFINE REQUIREMENTS.

COVER PLATE DETENT SPRING
TO CHECK

REMOVE COVER PLATE.
REQUIREMENT

MIN. 28 OZS.

MAX. 48 OZS.

TO START PLUNGER MOVING

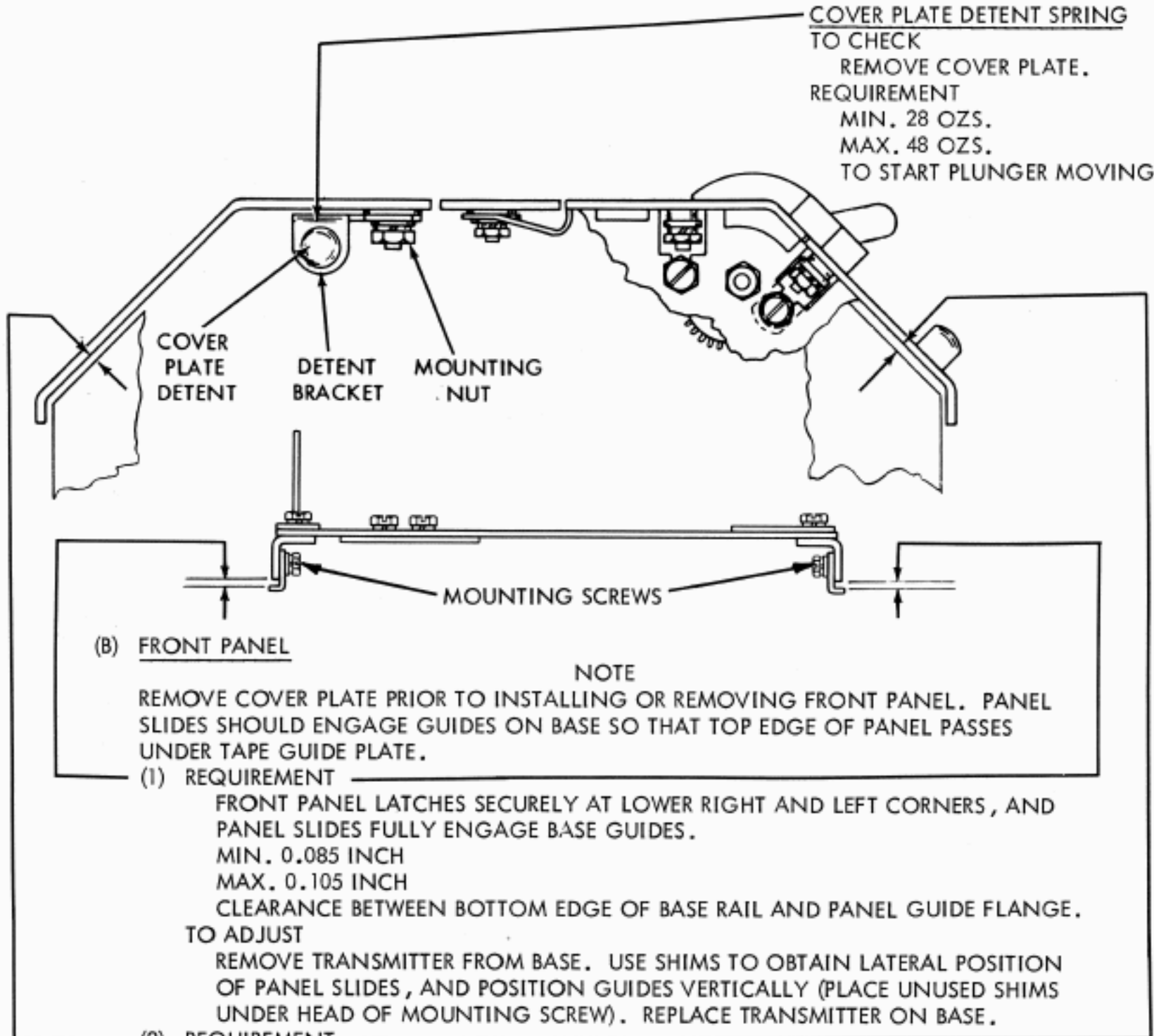

(B) FRONT PANEL

NOTE

REMOVE COVER PLATE PRIOR TO INSTALLING OR REMOVING FRONT PANEL. PANEL SLIDES SHOULD ENGAGE GUIDES ON BASE SO THAT TOP EDGE OF PANEL PASSES UNDER TAPE GUIDE PLATE.

(1) REQUIREMENT

FRONT PANEL LATCHES SECURELY AT LOWER RIGHT AND LEFT CORNERS, AND PANEL SLIDES FULLY ENGAGE BASE GUIDES.

MIN. 0.085 INCH

MAX. 0.105 INCH

CLEARANCE BETWEEN BOTTOM EDGE OF BASE RAIL AND PANEL GUIDE FLANGE.

TO ADJUST

REMOVE TRANSMITTER FROM BASE. USE SHIMS TO OBTAIN LATERAL POSITION OF PANEL SLIDES, AND POSITION GUIDES VERTICALLY (PLACE UNUSED SHIMS UNDER HEAD OF MOUNTING SCREW). REPLACE TRANSMITTER ON BASE.

(2) REQUIREMENT

MIN. 0.015 INCH

MAX. 0.060 INCH

CLEARANCE BETWEEN PANEL TOP EDGE AND FRONT EDGE OF COVER AND TAPE GUIDE PLATES. THE UPPER PANEL SIDES SHOULD NOT TOUCH THE COVER AND TAPE GUIDE PLATE EAVES.

TO ADJUST

WITH FRONT PANEL IN PLACE, LOOSEN PANEL GUIDE MOUNTING SCREWS AND POSITION THE GUIDE. TO FACILITATE ADJUSTMENT, REMOVE THE FOUR VIBRATION MOUNT NUTS AND SWING SUB-BASE AWAY.

FIGURE 1-31. COVER AND PANEL ASSEMBLY

b. SELF CONTAINED SET BASE (LBXB)

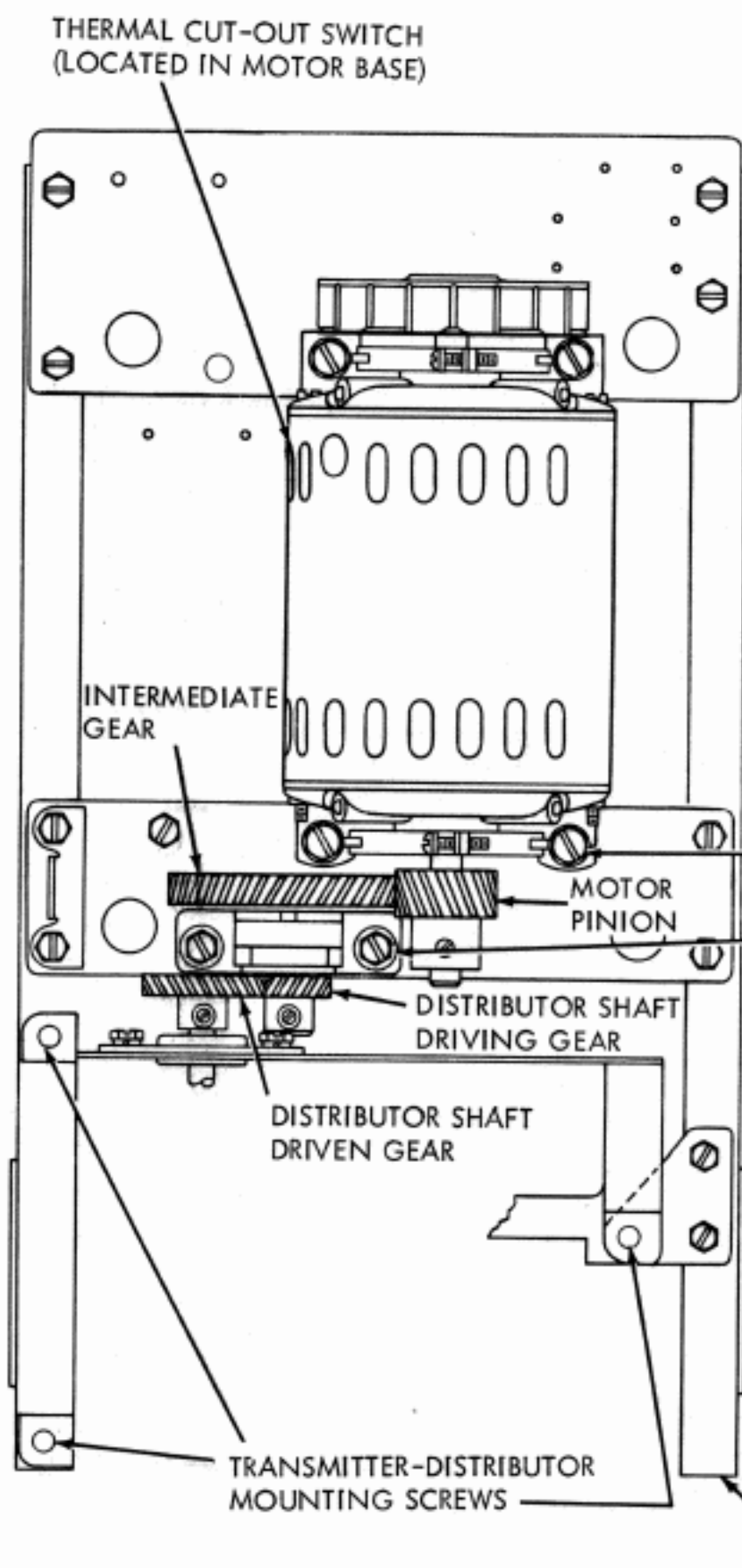

(A) INTERMEDIATE GEAR ASSEMBLY

NOTE

REMOVE GEAR GUARD.

(1) REQUIREMENT

AT LEAST 0.010 INCH CLEARANCE BETWEEN DISTRIBUTOR SHAFT DRIVING GEAR, AND INTERMEDIATE GEAR BRACKET BEARING CLAMP.

TO ADJUST

POSITION DRIVING GEAR WITH ITS MOUNTING SCREW LOOSENED.

(2) REQUIREMENT

SOME CLEARANCE BETWEEN DISTRIBUTOR SHAFT DRIVEN GEAR AND INTERMEDIATE GEAR BRACKET BEARING CLAMP.

TO ADJUST

POSITION INTERMEDIATE GEAR BRACKET WITH ITS MOUNTING SCREWS LOOSENED.

(3) REQUIREMENT

MIN. SOME
MAX. 0.003 INCH
CLEARANCE BETWEEN DISTRIBUTOR SHAFT DRIVING AND DRIVEN GEARS AT POINT WHERE BACKLASH IS MINIMUM.

(4) REQUIREMENT

INTERMEDIATE GEAR HOUSING PARALLEL TO BASE.

TO ADJUST

POSITION INTERMEDIATE GEAR BRACKET WITH ITS MOUNTING SCREWS LOOSENED.

(B) MOTOR PINION (SELF CONTAINED UNIT)

(1) REQUIREMENT

MIN. SOME
MAX. 0.003 INCH
BACKLASH BETWEEN MOTOR PINION GEAR AND INTERMEDIATE GEAR.

(2) REQUIREMENT

MOTOR PARALLEL TO BASE.

TO ADJUST

POSITION MOTOR WITH ITS MOUNTING SCREWS LOOSENED. TIGHTEN MOUNTING SCREWS. ROTATE SHAFT AND RECHECK REQUIREMENT.

CAUTION

IF THE MOTOR SHOULD BECOME BLOCKED FOR SEVERAL SECONDS, THE THERMAL CUT-OUT SWITCH WILL BREAK THE CIRCUIT. SHOULD THIS HAPPEN, ALLOW THE MOTOR TO COOL AT LEAST 5 MINUTES BEFORE MANUALLY DEPRESSING THE RED BUTTON. AVOID REPEATED DEPRESSION.

FIGURE 1-32. BASE AND MOTOR GEARS

c. MULTIPLE TRANSMITTER DISTRIBUTOR BASE (LMXB)

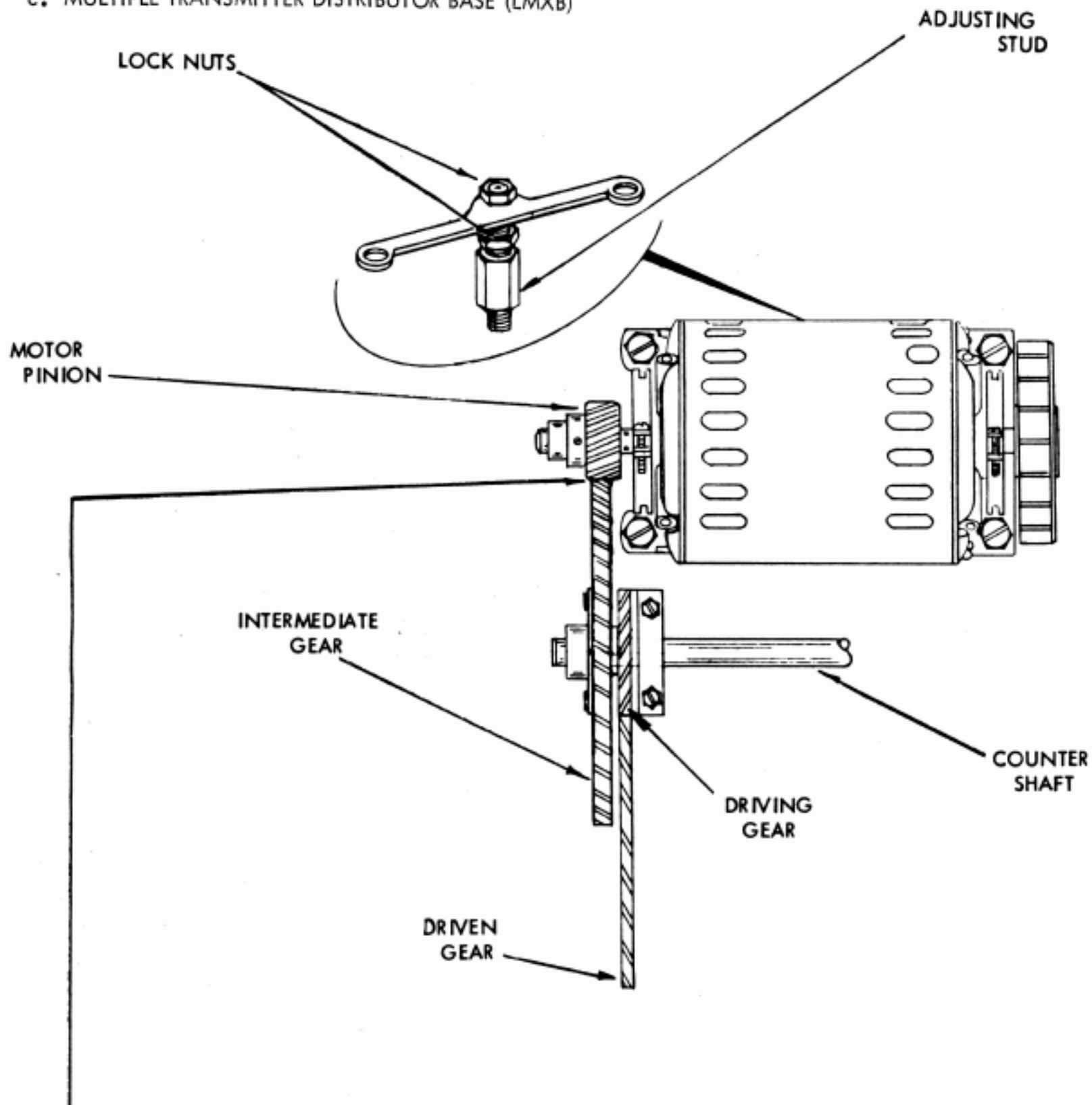

(A) MOTOR PINION (MULTIPLE MOUNTED UNIT)
 REQUIREMENT --- PINION AND INTERMEDIATE GEAR
 SHOULD HAVE A BARELY PERCEPTIBLE AMOUNT
 OF BACKLASH AT POINT OF MINIMUM CLEARANCE
 (CHECK FOR ONE REVOLUTION OF INTERMEDIATE GEAR).
 TO ADJUST --- WITH ITS LOCK NUTS LOOSENED,
 POSITION THE ADJUSTING STUD UP OR DOWN.

FIGURE 1-33. MULTIPLE TRANSMITTER DISTRIBUTOR BASE

**COUNTER SHAFT
REQUIREMENT**

BARELY PERCEPTIBLE AMOUNT OF BACKLASH BETWEEN COUNTER SHAFT DRIVING GEAR AND ITS ASSOCIATED TRANSMITTER DISTRIBUTOR DRIVEN GEAR AT POINT OF LEAST CLEARANCE.

TO ADJUST

- (1) WITH LOCATING PLATE MOUNTING SCREWS FRICTION TIGHT, POSITION PLATE AT CENTER OF ITS ADJUSTMENT RANGE.
- (2) INSERT AN LBXD UNIT (WITH CRADLE) INTO LEFT MOUNTING POSITION ON BASE. POSITION LOCATING PLATE TO MEET REQUIREMENT. TIGHTEN PLATE MOUNTING SCREWS.
- (3) REMOVE LBXD FROM LEFT POSITION, AND PLACE IT IN RIGHT MOUNTING POSITION. LOOSEN MOUNTING SCREWS ON COUNTERSHAFT PEDESTALS AND POSITION RIGHT END OF COUNTER SHAFT TO MEET REQUIREMENT.
- (4) TIGHTEN ALL MOUNTING SCREWS, CHECK FOR BINDS, AND RECHECK REQUIREMENTS IN RIGHT AND LEFT MOUNTING POSITIONS. REFINE IF NECESSARY.

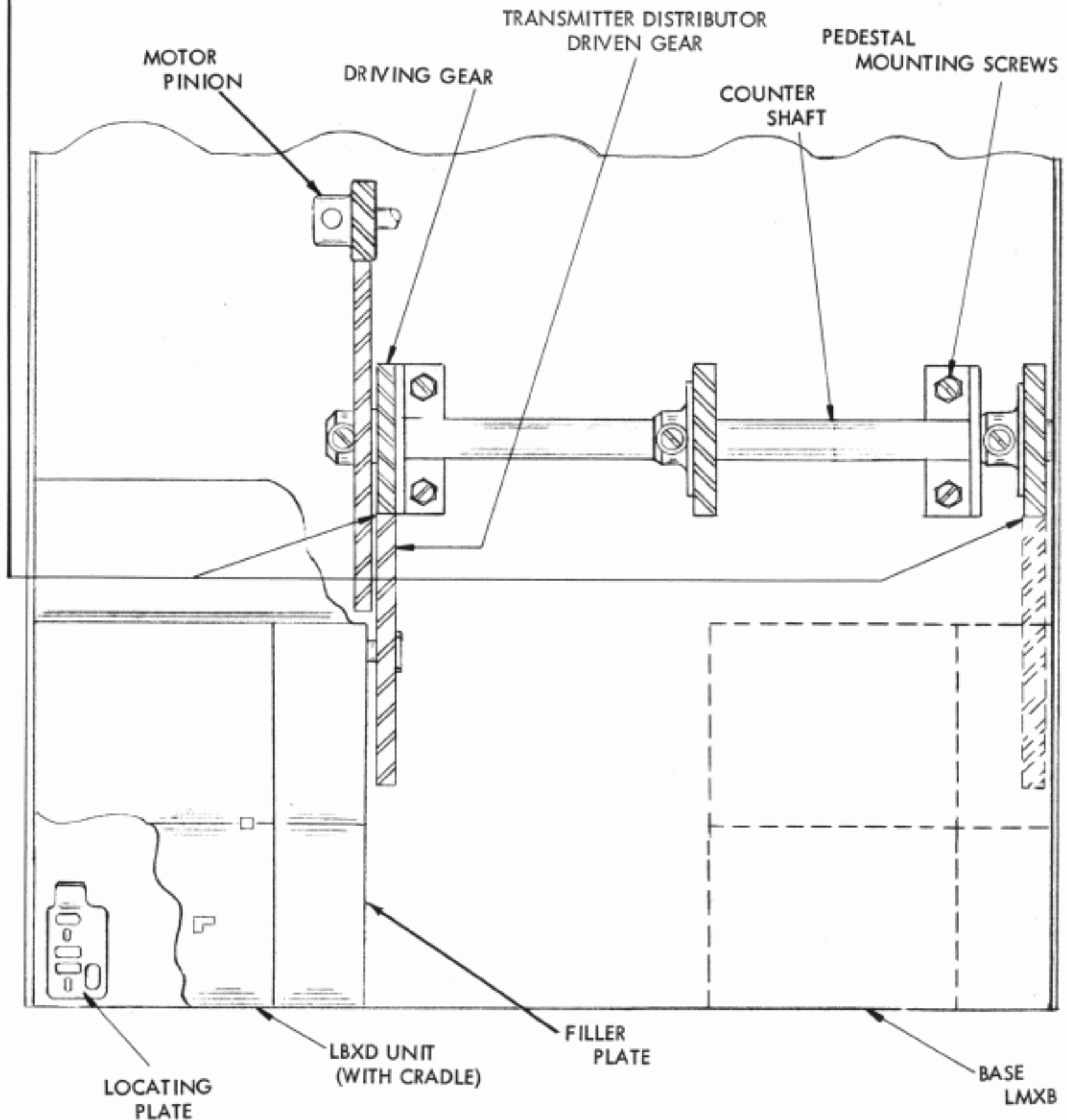

FIGURE 1-34. MULTIPLE TRANSMITTER DISTRIBUTOR BASE

(B) FILLER PLATES
REQUIREMENT

TOP SURFACE OF FILLER PLATE SHOULD ALIGN WITH UPPER SURFACE OF BOTH TOP PLATE AND TAPE GUIDE PLATE. COMMON EDGES SHOULD BEAR AGAINST EACH OTHER.

TO CHECK

- (1) LAY A STRAIGHTEDGE ACROSS TOP PLATES AND FILLER PLATES, 1/4" FROM COVER PLATE. GAP BETWEEN EACH PLATE AND STRAIGHTEDGE, 1/8" ON EACH SIDE OF EDGE BETWEEN TOP AND FILLER PLATES (5 EDGES) SHALL BE FLUSH TO 0.010 INCH.
- (2) LAY A STRAIGHTEDGE ACROSS TAPE GUIDE PLATES AND FILLER PLATES, 1/8" FROM LOWER EDGE OF TAPE GUIDE PLATES. GAP BETWEEN STRAIGHTEDGE AND EACH TAPE GUIDE PLATE 1/8" ON EACH SIDE OF EDGE BETWEEN TAPE GUIDE AND FILLER PLATES (5 EDGES) SHALL BE FLUSH TO 0.010 INCH.

TO ADJUST

POSITION FILLER PLATE AND ITS BRACKETS WITH THE BRACKET MOUNTING SCREWS AND PLATE MOUNTING NUTS FRICTION TIGHT.



NOTE

WHEN LESS THAN 3 LBXD UNITS ARE USED ON THE BASE, THE UNUSED COMPARTMENT CONTAINS A DUMMY UNIT. POSITION THE TOP PLATE AND COVER IN A MANNER SIMILAR TO ADJUSTMENT PROCEDURE (A).

(A) COVER PLATES

(1) REQUIREMENT

WITH THREE LBXD UNITS IN POSITION ON THE BASE, THE COVER PLATES SHOULD ALIGN HORIZONTALLY, AND THE MATING EDGE OF EACH COVER PLATE AND TOP PLATE SHALL BE FLUSH.

TO ADJUST

POSITION COVER PLATE WITH ITS DETENTING NUTS LOOSENED (SEE FIGURE

(2) REQUIREMENT

EDGE OF COVER PLATE OPPOSITE DRIVING GEAR SHALL ALIGN WITH EDGE OF TOP PLATE.

TO ADJUST

POSITION COVER PLATE WITH THE CORNER PLATE DETENT MOUNTING NUTS AND SPRING PLATE MOUNTING NUTS FRICTION TIGHT.

FIGURE 1-35. MULTIPLE TRANSMITTER DISTRIBUTOR BASE

d. AUTOMATIC SEND-RECEIVE SET TRANSMITTER DISTRIBUTOR BASE (LCXB)

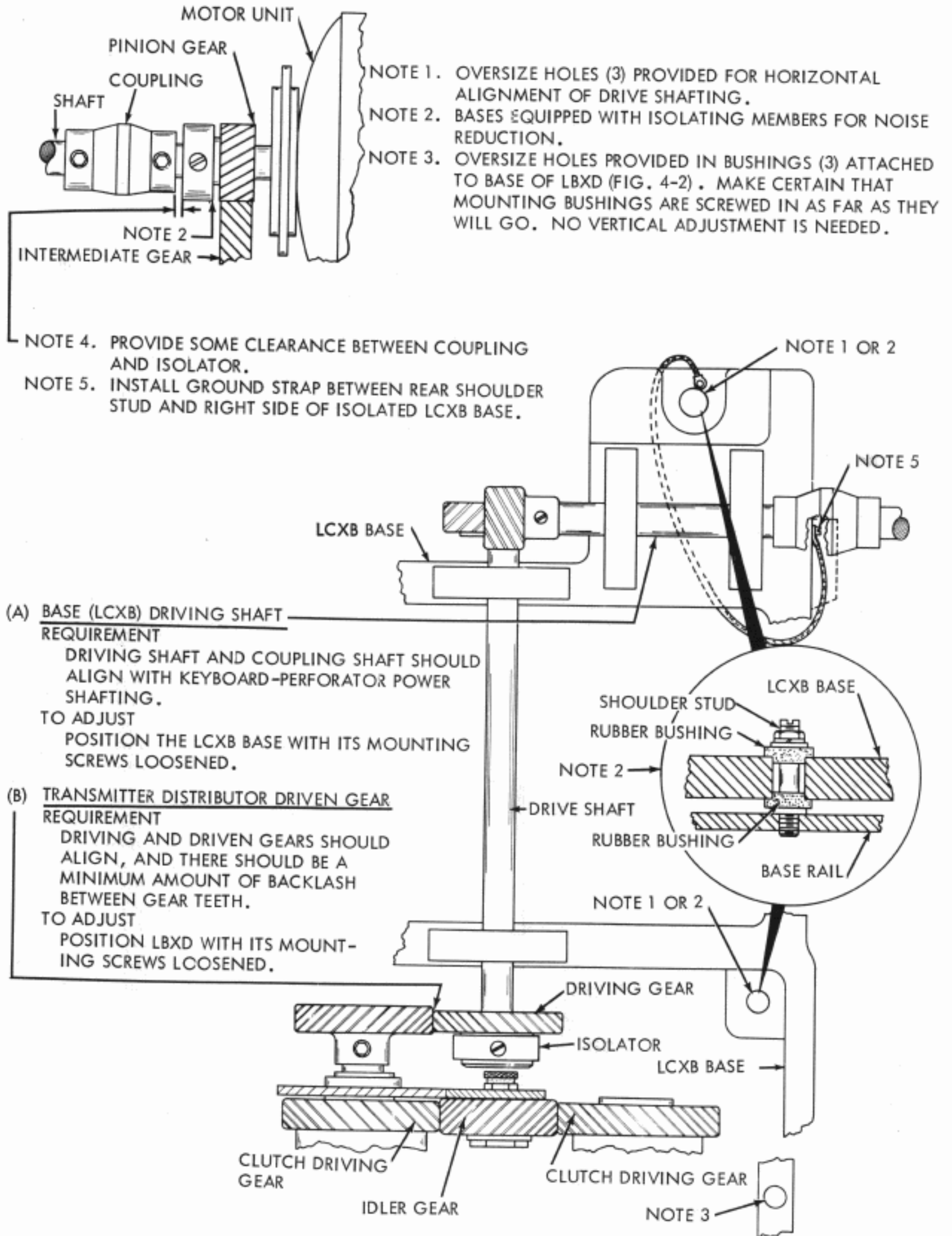
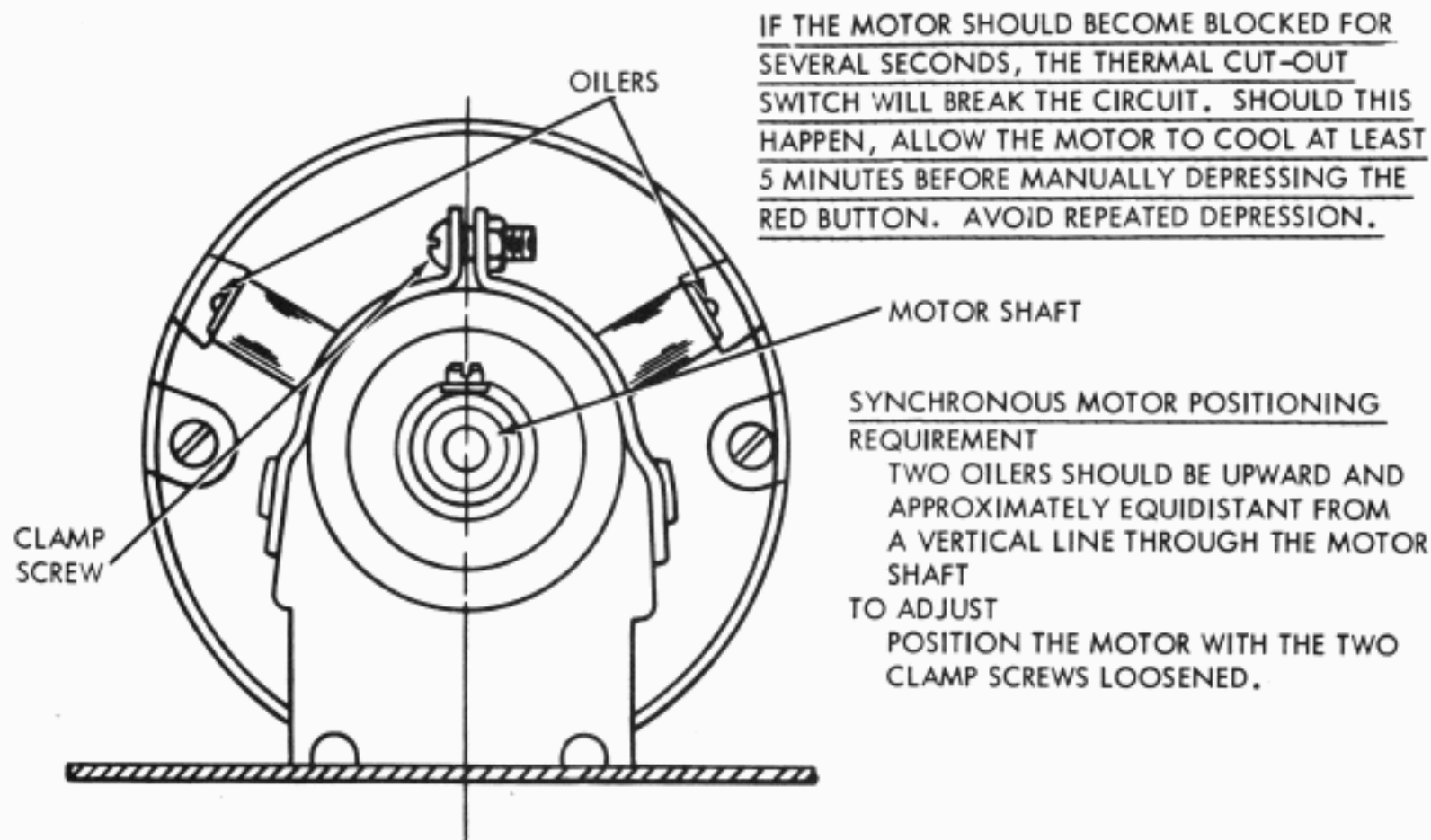

FIGURE 1-36. AUTOMATIC SEND RECEIVE SET TRANSMITTER DISTRIBUTOR BASE (LCXB)

e. SYNCHRONOUS AND GOVERNED MOTORS (LMU)GOVERNED MOTOR POSITIONING REQUIREMENT

MOTOR SHOULD BE CENTRALLY POSITIONED IN ITS RUBBERMOUNTS SO AS TO PROVIDE AT LEAST 0.020 CLEARANCE BETWEEN THE MOTOR HOUSING AND THE CRADLE AT THE GOVERNOR END. THE CABLE SHOULD ALSO CLEAR THE GROMMET IN THE SCREEN BY AT LEAST 0.030 INCH.

GOVERNOR CONTACT REQUIREMENTGOVERNOR CONTACTSMOVABLE CONTACT ARMCONTACT NUTSTATIONARY CONTACT ARMCONTACT ARM CLAMP SCREW AND POSTA. GOVERNOR CONTACT REQUIREMENT

THE CONTACTS SHOULD MEET SQUARELY AND NOT OVERLAP MORE THAN 0.010 INCH.

TO ADJUST POSITION THE STATIONARY CONTACT AND CONTACT ARM WITH THE CLAMP SCREW AND POST LOOSENED.

B. GOVERNOR CONTACT BACKSTOP REQUIREMENT

CLEARANCE BETWEEN THE MOVABLE CONTACT ARM AND ITS ECCENTRIC BACKSTOP.

MIN. 0.030 INCH

MAX. 0.050 INCH

TO ADJUST ROTATE THE ECCENTRIC BACKSTOP WITH CLAMPING SCREW LOOSENED.

FIGURE 1-37. SYNCHRONOUS AND GOVERNED MOTORS

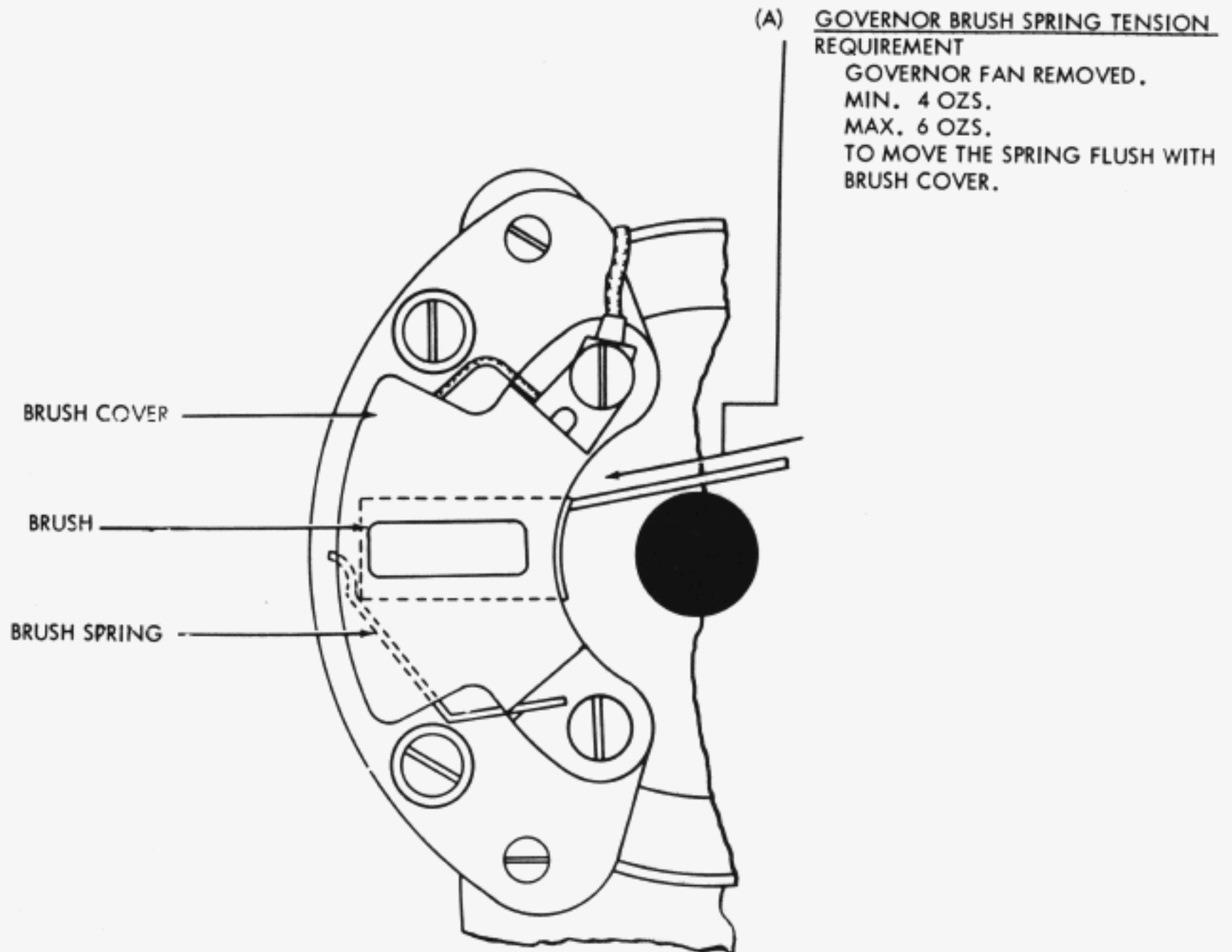

(B) GOVERNED MOTOR SPEED ADJUSTMENT
 REQUIREMENT ---

WITH THE TARGET ILLUMINATED AND VIEWED THROUGH THE VIBRATING SHUTTERS OF A 120 VPS TUNING FORK, THE SPOTS SHOULD APPEAR STATIONARY WHILE THE MOTOR IS ROTATING.
 TO ADJUST ---

STOP THE MOTOR AND TURN THE ADJUSTING SCREW AS INDICATED ON THE GOVERNOR COVER.

FIGURE 1-38. SYNCHRONOUS AND GOVERNED MOTORS

f. CABINETS

(A) REAR DOORS
REQUIREMENT

WHEN FULLY CLOSED, DOORS SHOULD BE FLUSH WITH
STRUCTURAL MEMBER OF CABINET.

TO ADJUST

BEND FLANGE AT UPPER RIGHT HAND CORNER OF LEFT
DOOR (AS VIEWED FROM REAR).

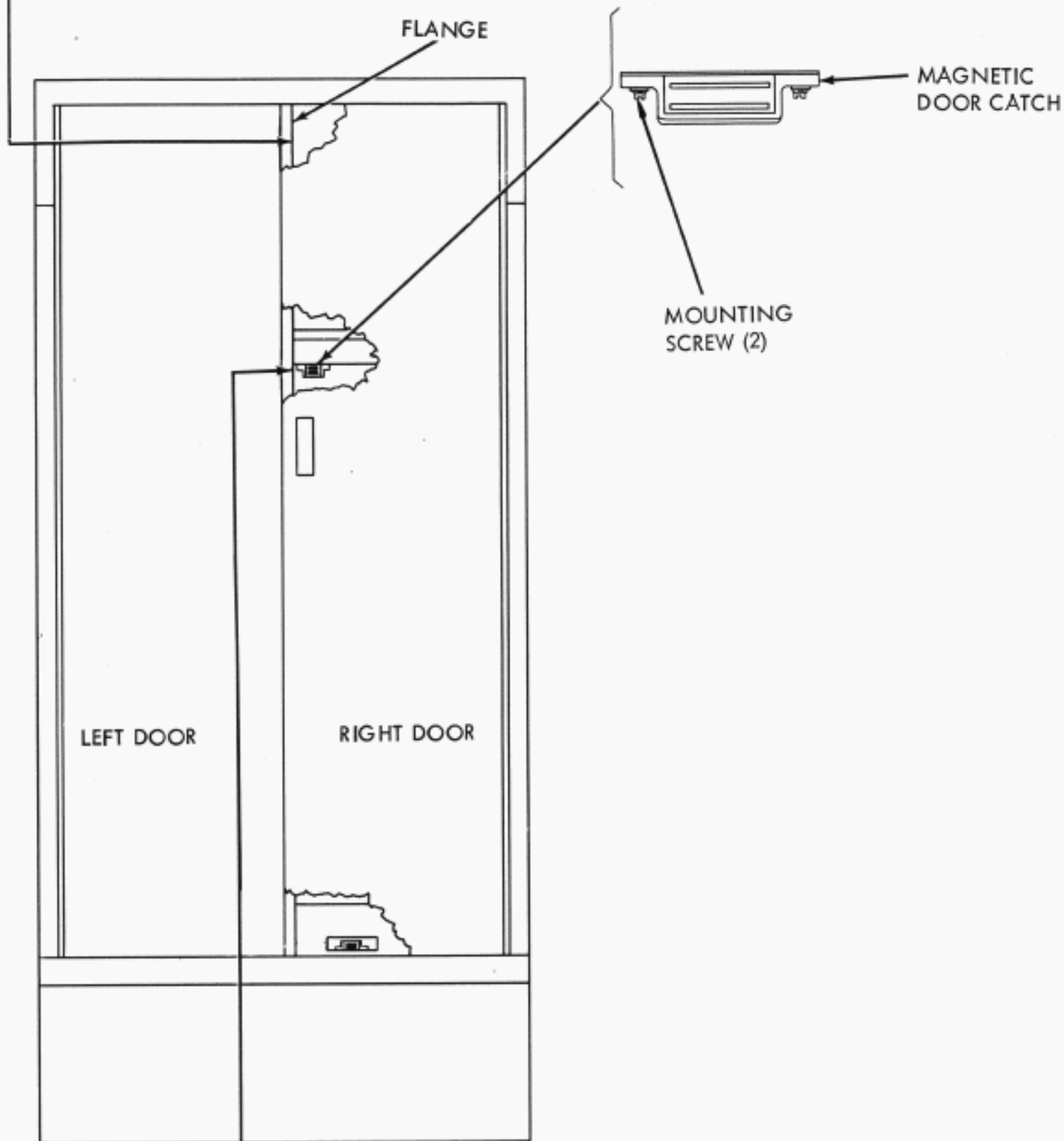
(B) REAR DOOR CATCHES
REQUIREMENT

WHEN CLOSED, DOORS SHOULD FIT FIRMLY AGAINST
MAGNETIC DOOR CATCHES.

TO ADJUST

POSITION CATCHES WITH MOUNTING SCREWS LOOSENED.

FIGURE 1-39. CABINET, MULTIPLE MOUNTING

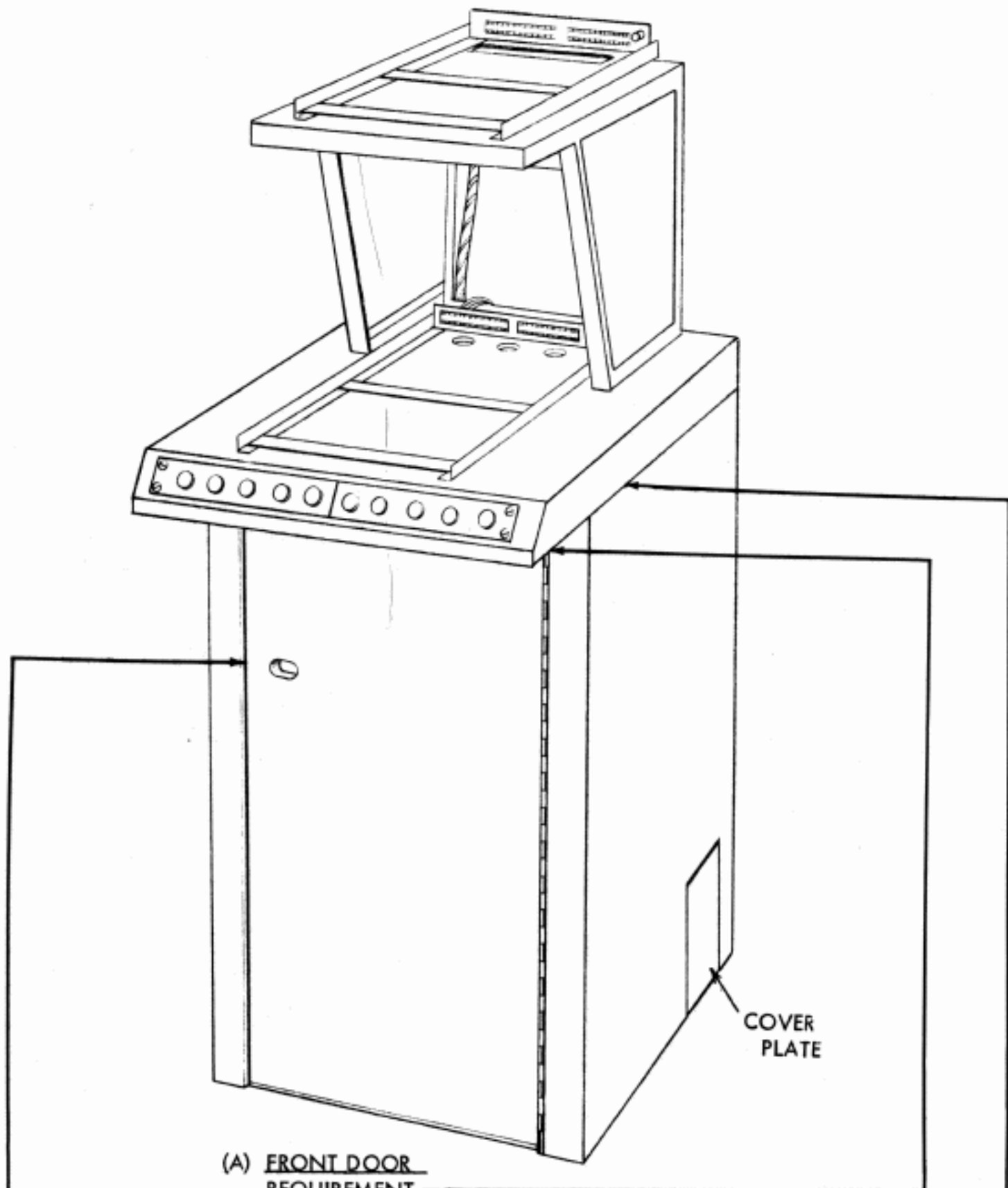

(A) FRONT DOOR
REQUIREMENT

CLEARANCE BETWEEN TOP EDGE OF DOOR AND LOWER EDGE OF TABLE TOP, AND BETWEEN LOWER EDGE OF DOOR AND THE BOTTOM EDGE OF CABINET SHOULD BE EQUAL (GAUGE BY EYE).

TO ADJUST
WITH HINGE MOUNTING SCREWS LOOSENED,
POSITION THE HINGE.

(C) FRONT DOOR LATCH
REQUIREMENT

LATCH BOLT EXTENDS:
MIN. $5/32$ INCH
MAX. $7/32$ INCH
BETWEEN EDGE OF DOOR.

TO ADJUST
POSITION BOLT WITH ITS CLAMPING
SCREWS LOOSENED.

(B) TABLE TOP
REQUIREMENT

TABLE TOP FLUSH ON BOTH SIDES.

TO ADJUST
WITH ITS MOUNTING SCREWS LOOSENED,
POSITION TOP IN ITS ELONGATED MOUNTING HOLES.

FIGURE 1-40. CABINET, TABLE TYPE

TAPE LID - EARLY DESIGN (SEE FIGURE 1-16 FOR LATE DESIGN)

NOTE

REMOVE TOP AND TAPE GUIDE PLATES. LUBRICATE PRIOR TO ADJUSTMENT.

(1) REQUIREMENT (PRELIMINARY)

MIN. SOME
MAX. 0.010 INCH.

CLEARANCE BETWEEN PIVOT SHOULDER AND TAPE LID WHEN LID IS PRESSED AGAINST NOTCH IN TAPE GUIDE PLATE, AND FEED WHEEL SLOTS AND TAPE-OUT PIN HOLES ARE LINED UP.

TO ADJUST

LOOSEN TAPE LID BRACKET MOUNTING NUTS. USING A #155743 GAUGE, LINE UP FEED WHEEL GROOVE IN TAPE LID WITH SLOT IN TAPE GUIDE PLATE. POSITION TAPE LID BRACKET TO MEET REQUIREMENT.

(2) REQUIREMENT

TAPE LID FRONT BEARING SURFACE (A) SHALL TOUCH TAPE GUIDE PLATE. CLEARANCE (B) MEASURED AT FIN OF TAPE LID IN LINE WITH REAR TAPE GUIDE (SEE NOTE 2):

MIN. 0.010 INCH
MAX. 0.018 INCH

NOTE 1

WHEN BOTH PLATES ARE ASSEMBLED ON UNIT, LEFT EDGE OF LID MAY TOUCH TOP PLATE AND SOME CHANGE IN THIS CLEARANCE MAY BE EXPECTED.

TO ADJUST

WITH TAPE LID BEARING BRACKET MOUNTING SCREWS FRICTION TIGHT, AND TAPE LID PRESSED AGAINST TAPE GUIDE PLATE, POSITION BRACKET. RECHECK REQUIREMENT (1).

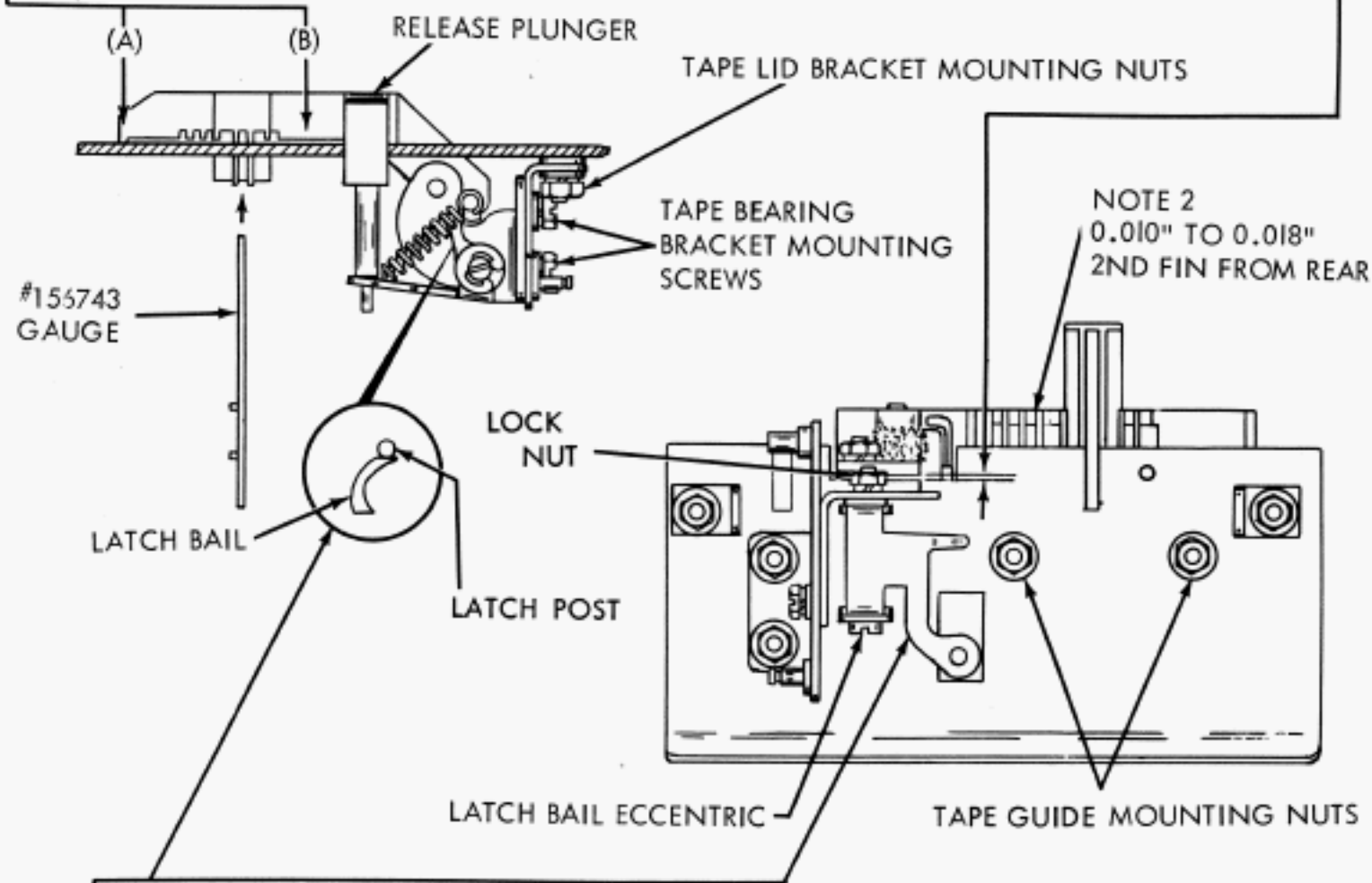

(3) REQUIREMENT

RELEASE PLUNGER SHALL HAVE SOME END PLAY WHEN LID IS LATCHED AGAINST TAPE GUIDE PLATE.

TO ADJUST

WITH ECCENTRIC MOUNTING POST LOCK NUT FRICTION TIGHT AND LID RAISED, ROTATE HIGH PART OF ECCENTRIC TOWARD TAPE GUIDE PLATE. CLOSE LID AND AND ROTATE ECCENTRIC TOWARD BRACKET UNTIL LATCH JUST FALLS UNDER FLAT ON POST. RECHECK BY DEPRESSING PLUNGER WITH LID HELD DOWN. TIP OF LATCH SHOULD CLEAR POST AS PLUNGER IS OPERATED.

FIGURE 1-41. TAPE LID MECHANISM

4. DISTRIBUTOR AND TRANSMITTER CONTACT STROBING

a. GENERAL

- (1) The following adjustment procedure outlines pulse length requirements for transmitter distributor units operating at various speeds (OPM) and transmission patterns (i.e. 7.00, 7.42, or 7.50 unit code). In all cases, both the test set and the unit under test must be operating at the same speed for proper strobing. All pulse length requirements are made with respect to a 7.42 unit code test set scale, regardless of the cam arrangement of the transmitter distributor.
- (2) When discussing the operating speed of a unit, a number of different terms may be used to represent the same speed. A typical teletypewriter or data channel, for example, may be described in terms of modulation rate (BAUD), or rate of transmission of information (WPM or OPM). In the following strobing procedure, reference is made to both OPM and BAUD. In other parts of this bulletin, reference is also made to WPM. These three terms, although defined differently, can be used interchangeably to represent the operating speed of any Teletype Transmitter Distributor unit.
- (3) The term OPM is an abbreviation for operations per minute. OPM is defined as follows:

$$\text{Formula (1)} \quad \text{OPM} = \frac{c}{\text{sec}} \times 60 \frac{\text{sec}}{\text{min}}$$

That is, the speed of a unit, in operations per minute (OPM), is equal to the transmission rate, in characters per second (c/sec), times 60 sec/min. Since a character is transmitted each operation, this term provides a measure of the amount of information which may be transmitted by the unit.

- (4) The term WPM is an abbreviation for words per minute. WPM is defined as follows:

$$\text{Formula (2)} \quad \text{WPM} = \frac{c}{\text{sec}} \times 60 \frac{\text{sec}}{\text{min}} \div \frac{6 \frac{c}{\text{word}}}{1}, \text{ or } \text{WPM} = \frac{c}{\text{sec}} \times 10$$

That is, the speed of a unit, in words per minute (WPM), is equal to the transmission rate, in characters per second (c/sec), times 60 sec/min, divided by 6 c/word. It may be noted, from observation of the defining formulas for OPM and WPM, that a close relationship exists between these terms. The only difference in the defining formulas is that equation (2) has an extra term (6 c/word) which appears as a denominator. From the above two equations, a third one may be derived. Since $\text{OPM} = c/\text{sec} \times 60 \text{ sec}/\text{min}$, we can replace the numerator of equation (2) -- which is $c/\text{sec} \times 60 \text{ sec}/\text{min}$ -- by OPM. The result will be:

$$\text{Formula (3)} \quad \text{WPM} = \frac{\text{OPM}}{6 \frac{c}{\text{word}}}, \text{ OPM} = (\text{WPM}) (6 \frac{c}{\text{word}})$$

Formula (3) is a valid one to use when converting from one term to the other as long as the exact values, and not approximate values, for WPM or OPM are used. For example, one of the standard Teletype Transmitter Distributor operating speeds is generally stated as being 60 WPM. This value, however, is only an approximate one used to simplify discussion of the unit. In all cases, units transmitting 60 WPM are actually operating at 368 OPM. By formula (3), it can readily be calculated that the unit is transmitting not 60 WPM, but 61.33 WPM:

$$\text{WPM} = \frac{\text{OPM}}{6 \frac{c}{\text{word}}}; \text{ WPM} = \frac{368}{6} = \underline{\underline{61.33}}$$

The following table is provided to aid in determining the operating speed of a unit when either OPM or WPM (actual or approximate) is known. It is not a complete listing of all available speeds, but is representative of the speeds most in use.

Operations Per Minute (OPM)	Words Per Minute (WPM)	
	ACTUAL	APPROXIMATE
368	61.33	60
390	65.00	65
428.6	71.43	70
460	76.66	75
600	100.00	100
636	106.00	106
642	107.15	107

- (5) The remaining term, BAUD, is defined as a unit of telegraphic speed--or modulation rate--which indicates the time duration of the shortest signal element of a transmitted character. The defining formula for BAUD is:

$$\text{Formula (4)} \quad \text{BAUD} = \frac{\text{OPM} \times \text{UNIT CODE}}{60 \frac{\text{sec}}{\text{min}}} \quad \text{or}$$

$$\text{Formula (5)} \quad \text{BAUD} = \frac{c}{\text{sec}} \times \text{UNIT CODE}$$

This term differs from the first two defined in that, while OPM and WPM provide an indication of the amount of information transmitted by a unit, the term BAUD is most correctly used when referring to the binary digital modulation rate of the information transmitted.

- (6) The objective of this discussion has been to introduce the technician to the above terms, so that their usage will be better understood by him. Finally, by use of the five defining formulas, the technician should be able to convert from one type of speed terminology to another, if the need should arise.

b. CONTACT STROBING PROCEDURE - 1 CYCLE CAM

NOTE

To strobe the distributor and sensing contacts, a Signal Distortion Test Set (DXD) or Stroboscopic Test Set (LSS) may be used. For operation of these sets, refer to Bulletin 181B or 261B respectively.

(1) Distributor Contacts - 5 Level Units

NOTE

The following procedure pertains to the LBXD1, 2, 4, 5, 6, 7, 8, 9, 11, 14, 16, 17, 18, 21, 22, and 23, transmitter distributor units.

- (a) Preliminary - Connect a test set to the output of the distributor contacts. Test set and transmitter distributor must be operating at the same speed.
- (b) Stop Contact Requirement - Insert a "blank" perforated tape into the transmitter distributor sensing head. Trip the distributor clutch (on some units, the distributor clutch may be tripped electrically via operation of the sensing shaft). Orient the test set scale so the 142 mark of its stop segment is aligned with the end of the stop pulse image.

Requirement (See Figure 1)

Length of stop pulse to be:
 106 scale divisions (7.00 unit code cam)
 148 scale divisions (7.50 unit code cam)

To Adjust

Rotate distributor stop contact adjusting screw.

NOTE 1

- (1) Allowable pulse variation for LBXD 1, 2, 8, 9, 11, 16, 17, 18, 21, and 22 is +3%.
- (2) Allowable pulse variation for LBXD 4, 5, 6, 7, 14, and 23 is +4%.

NOTE 2

4% is equivalent to 4.24 scale divisions (7.00 unit code), 5.68 scale divisions (7.42 unit code), and 5.92 scale divisions (7.50 unit code). 3% is equivalent to 3.18 scale divisions (7.00 unit code), 4.26 scale divisions (7.42 unit code), and 4.44 scale divisions (7.50 unit code).

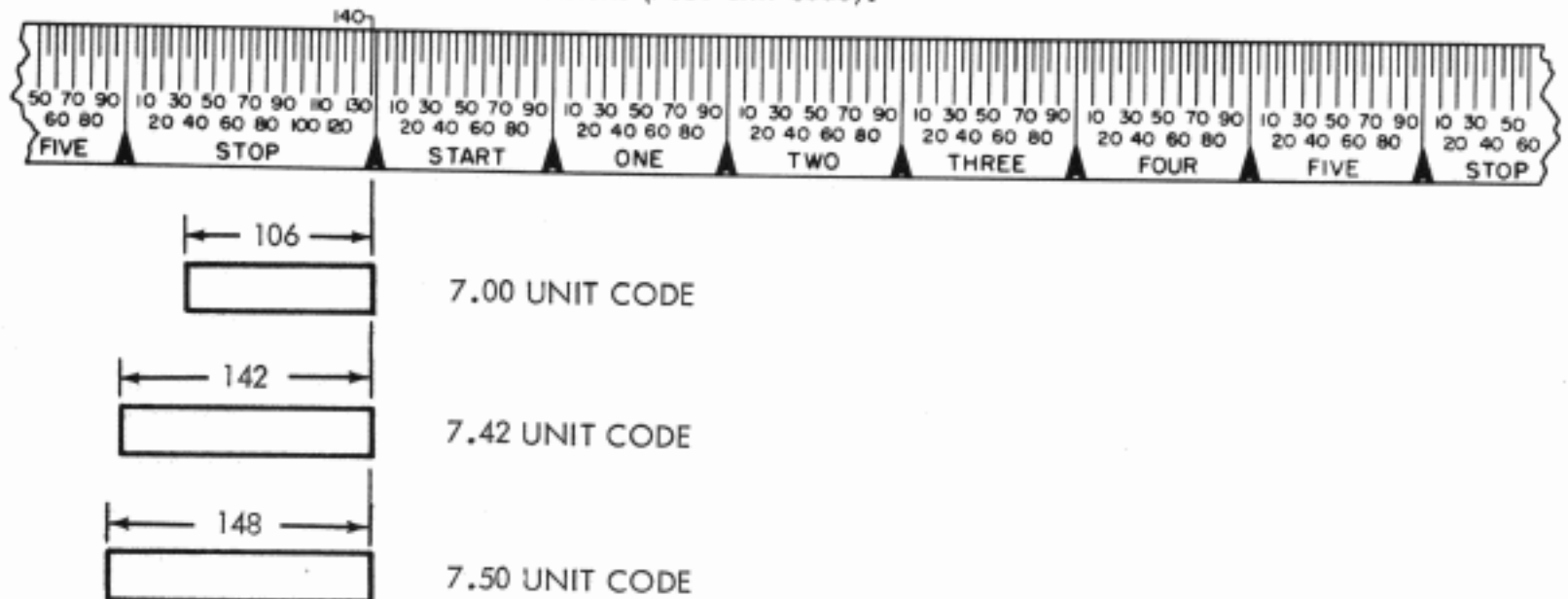

FIGURE 1. STOP CONTACT REQUIREMENTS

- (c) #2 and #4 Contact Requirements - Replace the "blank" perforated tape with an "R" perforated tape. Align the end of the stop pulse image with the 142 scale division on the stop segment of the test scale.

Requirement (See Figures 2, 3, and 4)

#2 and #4 pulse images equal in total length within +3% (LBXD 1, 2, 8, 9, 11, 16, 17, 18, 21, and 22), or +4% (LBXD 4, 5, 6, 7, 14, and 23) of each end of the pulse image transition points on the test set scale (see Table 1).

To Adjust

Rotate #2 and #4 contact adjusting screws.

- (d) #1, #3 and #5 Contact Requirements - Replace the "R" perforated tape with a "Y" perforated tape. Align the end of the stop pulse image with the 142 scale division on the stop segment of the test set scale.

Requirement (See Figures 2, 3, and 4)

#1, #3, and #5 pulse images equal in total length within +3% (LBXD 1, 2, 8, 9, 11, 16, 17, 18, and 22), or +4% (LBXD 4, 5, 6, 7, 14, and 23) of each end of the pulse image transition points on the test set scale (See Table 1).

To Adjust

Rotate #1, #3, and #5 contact adjusting screws.

NOTE 1

4% is equivalent to 4.24 scale divisions (7.00 unit code), 4.00 scale divisions (7.42 unit code), and 3.96 scale divisions (7.50 unit code). 3% is equivalent to 3.18 scale divisions (7.00 unit code), 3.00 scale divisions (7.42 unit code), and 2.97 scale divisions (7.50 unit code).

TABLE 1

PULSE IMAGE TRANSITION POINTS ON TEST SET SCALE

TEST SCALE SEGMENT	7.00 UNIT CODE		7.42 UNIT CODE		7.50 UNIT CODE	
	BEGIN AT SCALE DIV.	END AT SCALE DIV.	BEGIN AT SCALE DIV.	END AT SCALE DIV.	BEGIN AT SCALE DIV.	END AT SCALE DIV.
STOP	36 IN STOP	142 IN STOP	0 IN STOP	142 IN STOP	94 IN #5	142 IN STOP
1	6 IN #1	12 IN #2	0 IN #1	100 IN #1	99 IN START	98 IN #1
2	12 IN #2	18 IN #3	0 IN #2	100 IN #2	98 IN #1	97 IN #2
3	18 IN #3	24 IN #4	0 IN #3	100 IN #3	97 IN #2	96 IN #3
4	24 IN #4	30 IN #5	0 IN #4	100 IN #4	96 IN #3	95 IN #4
5	30 IN #5	36 IN STOP	0 IN #5	100 IN #5	95 IN #4	94 IN #5

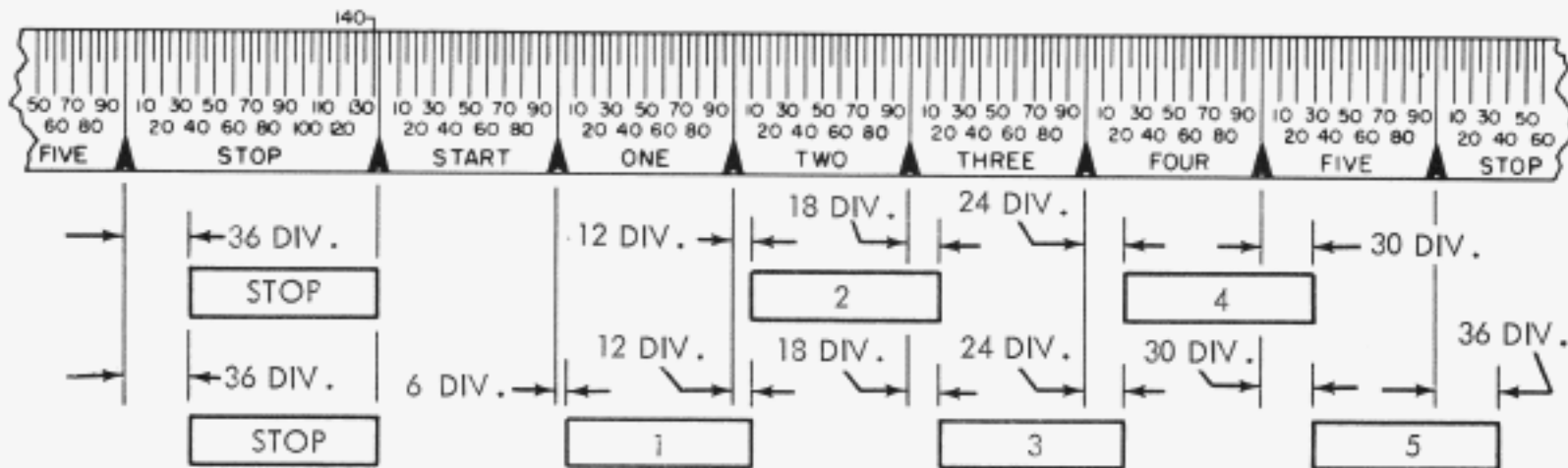

FIGURE 2. DISTRIBUTOR CONTACT REQUIREMENTS - 7.00 UNIT CODE

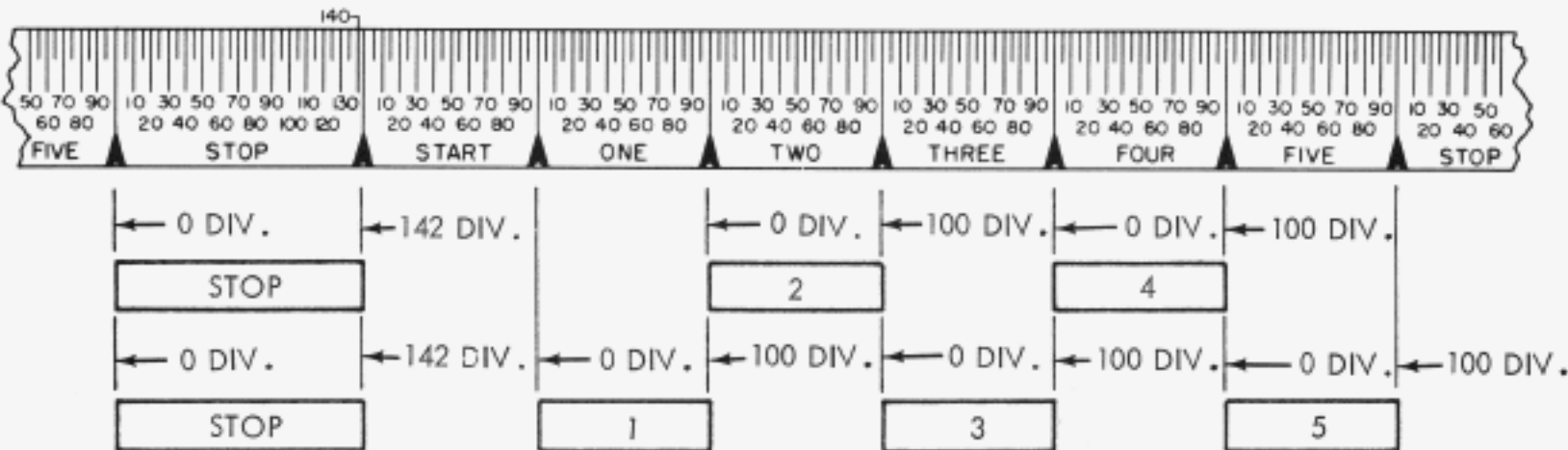

FIGURE 3. DISTRIBUTOR CONTACT REQUIREMENTS - 7.42 UNIT CODE

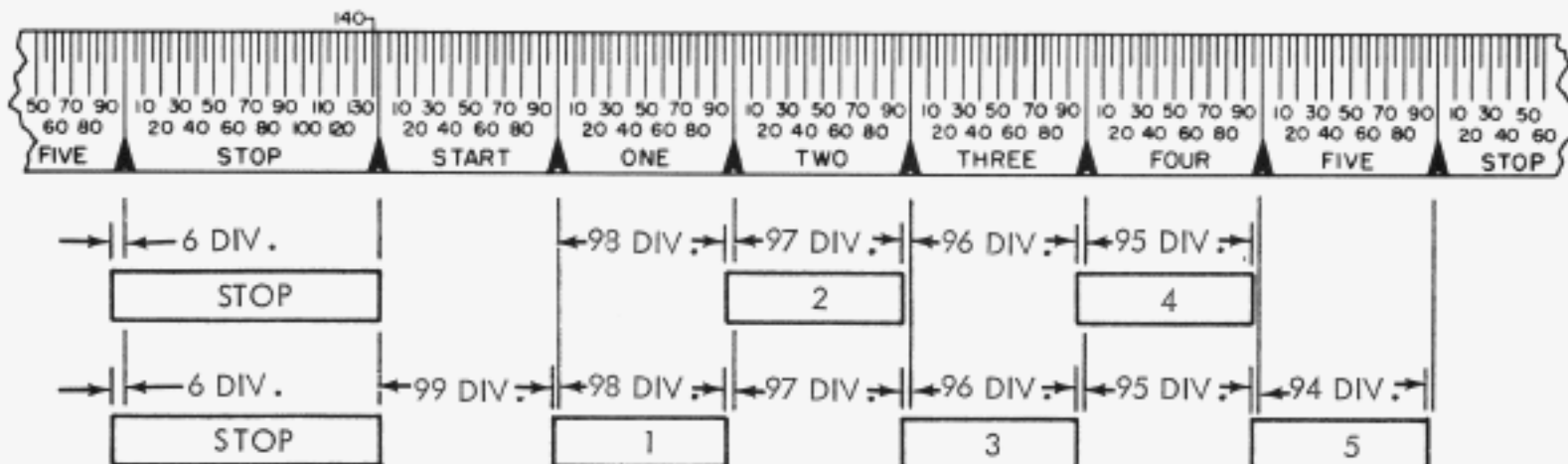

FIGURE 4. DISTRIBUTOR CONTACT REQUIREMENTS - 7.50 UNIT CODE

NOTE 2

To determine the end of the number 5 pulse image, it may be necessary to hold the stop contact open.

(2) Distributor Contacts - 8 Level Units

- (a) Stop Contact Requirement - The following procedure pertains to the LBXD800 Transmitter Distributor unit. Connect the test set and load a "blank" perforated tape into the unit as outlined in paragraph 4.a.(1)(a) and (b).

Requirement (See Figure 5)

Length of stop pulse to be:

135 scale divisions (11.00 unit code cams - 8 level).

To Adjust

Rotate distributor stop contact adjusting screw.

NOTE

Allowable pulse variation for LBXD800 is +3%. 3% is equivalent to 4.05 scale divisions for an 11.00 unit code - 8 Level unit.

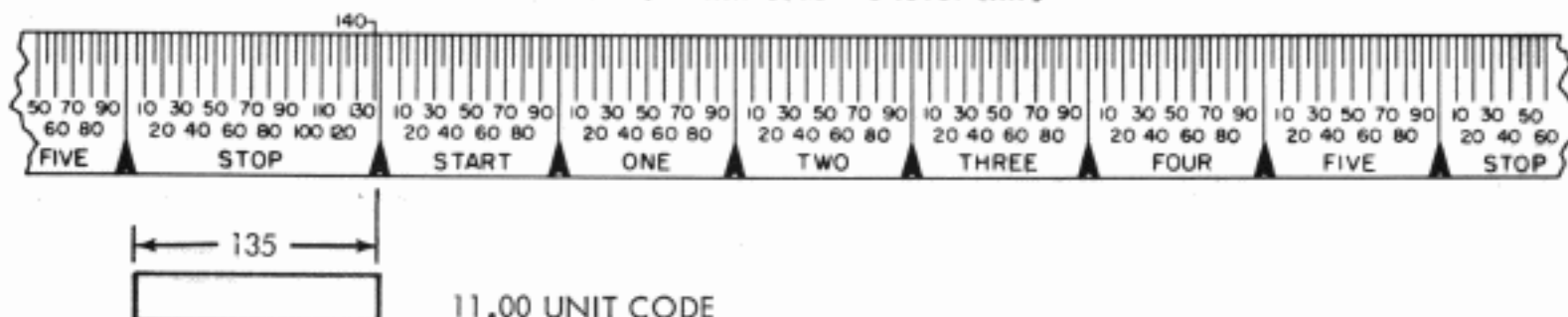

FIGURE 5. STOP CONTACT REQUIREMENT

- (b) #0, #2, #4, and #6 Contacts - Replace the "blank" perforated tape with a tape having the #0, #2, #4, and #6 levels punched. Align the end of the stop pulse image with the 142 scale division on the stop segment of the test scale.

Requirement (See Figure 6)

#0, #2, #4, and #6 pulse images equal in total length within $\pm 3\%$ of each end of the pulse image transition points on the test set scale (see Table 2).

To Adjust

Rotate #0, #2, #4, and #6 contact adjusting screws.

- (c) #1, #3, #5, and #7 Contacts - Replace the 0-2-4-6 perforated tape with a tape having the #1, #3, #5, and #7 levels punched. Align the end of the stop pulse image with the 142 scale division on the stop segment of the test set scale.

Requirement (See Figure 6)

#1, #3, #5, and #7 pulse images equal in total length within $\pm 3\%$ of each end of the pulse image transition points on the test set scale (see Table 2).

To Adjust

Rotate #1, #3, #5, and #7 contact adjusting screws.

NOTE 1

3% is equivalent to 2.03 scale divisions (11.00 unit code - 8 level).

NOTE 2

To determine the end of the number 7 pulse image, it may be necessary to hold the stop contact open.

TABLE 2
EIGHT LEVEL PULSE IMAGE TRANSITION POINTS
ON FIVE LEVEL TEST SET SCALE - 11.00 UNIT CODE

CODE PULSE	END AT SCALE DIVISION	BEGIN AT SCALE DIVISION
STOP	7 IN STOP SEGMENT	142 IN STOP SEGMENT
0	67 IN START SEGMENT	35 IN #1 SEGMENT
1	35 IN #1 SEGMENT	2 IN #2 SEGMENT
2	2 IN #2 SEGMENT	70 IN #2 SEGMENT
3	70 IN #2 SEGMENT	37 IN #3 SEGMENT
4	37 IN #3 SEGMENT	5 IN #4 SEGMENT
5	5 IN #4 SEGMENT	72 IN #4 SEGMENT
6	72 IN #4 SEGMENT	40 IN #5 SEGMENT
7	40 IN #5 SEGMENT	7 IN STOP SEGMENT

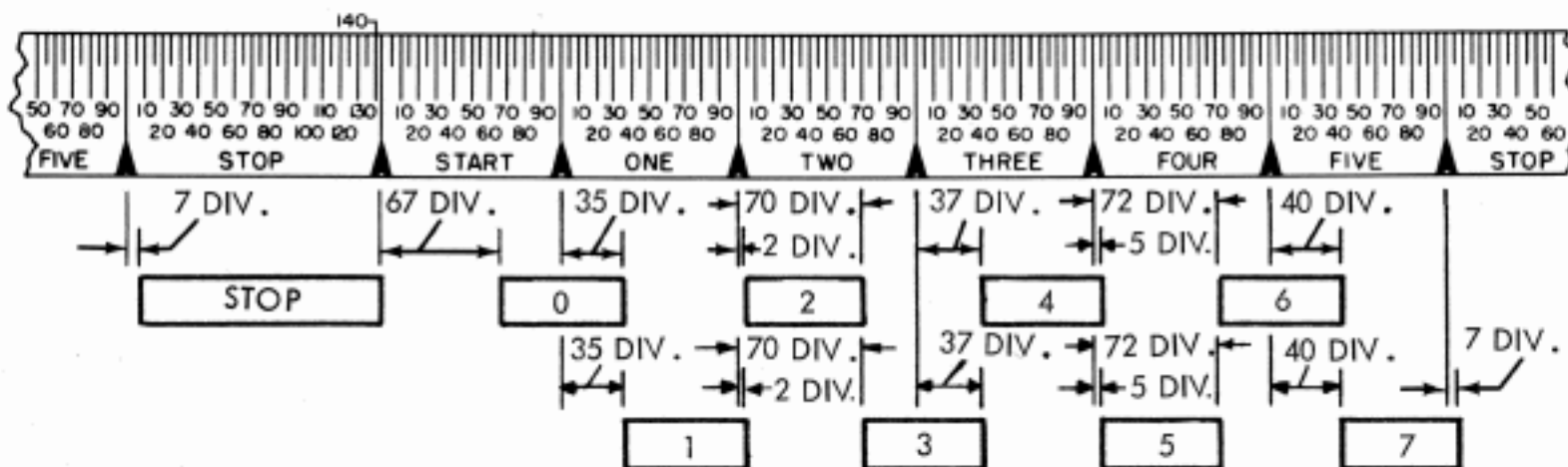

FIGURE 6. DISTRIBUTOR CONTACT REQUIREMENTS - 11.00 UNIT CODE

(3) Distributor Auxiliary Contacts - 5 and 8 Level Units (See Figure 7)

(a) Requirement - Auxiliary "C" Contact (LBXD 1, 2, 16, and 18 - 7.00 unit code)

Auxiliary "C" contact should:

Close at 29.5 ± 5 divisions in start segment

Open at 48 ± 8 divisions in stop segment

*Close at 39 ± 6 divisions in start segment

Open at 95 ± 5 divisions in #5 segment

*LBXD16

To Adjust

Rotate distributor auxiliary contact adjusting screw.

(b) Requirement - Auxiliary "C" Contact (LBXD 1 and 2 - 7.42 unit code)

Auxiliary "C" contact should:

Close at 11.5 ± 5 divisions in start segment

Open at 13 ± 8 divisions in stop segment

To Adjust

Rotate distributor auxiliary contact adjusting screw.

(c) Requirement - Auxiliary Contact (LBXD 4, 5, 6, 7, 11, 14, and 23 - 7.42 unit code)

Auxiliary contact should:

Close at 32 ± 15 divisions in start segment

Open at 29 ± 15 divisions in stop segment

To Adjust

Rotate distributor auxiliary contact adjusting screw.

(d) Requirement - Auxiliary "B" Contact (LBXD 7 and 14 - 7.42 unit code)

Auxiliary "B" contact should:
 Close at 25 ± 15 divisions in #1 segment
 Open at 75 ± 15 divisions in #5 segment

To Adjust
 Rotate distributor auxiliary contact adjusting screw.

(e) Requirement - Auxiliary Contact (LBXD 9 - 7.42 unit code)

Auxiliary contact should:
 Close at 32 ± 20 divisions in start segment
 Opens at 65 ± 10 divisions in stop segment.

To Adjust
 Rotate distributor auxiliary contact adjusting screw.

(f) Requirement - Auxiliary Contact (LBXD 8 and 22 - 7.42 unit code)

Auxiliary contact should:
 Close at 110 ± 5 divisions in stop segment
 Open at 31 ± 8 divisions in stop segment

To Adjust
 Rotate distributor auxiliary contact adjusting screw.

(g) Requirement - Auxiliary Contact (LBXD 800 - 11.00 unit code)

See requirement (f).

(h) Requirement - Auxiliary Contact (LBXD 17 and 21 - 7.50 unit code)

Auxiliary contact should:
 Close at 32 ± 20 divisions in start segment
 Open at 30 ± 10 divisions in stop segment

To Adjust
 Rotate distributor auxiliary contact adjusting screw.

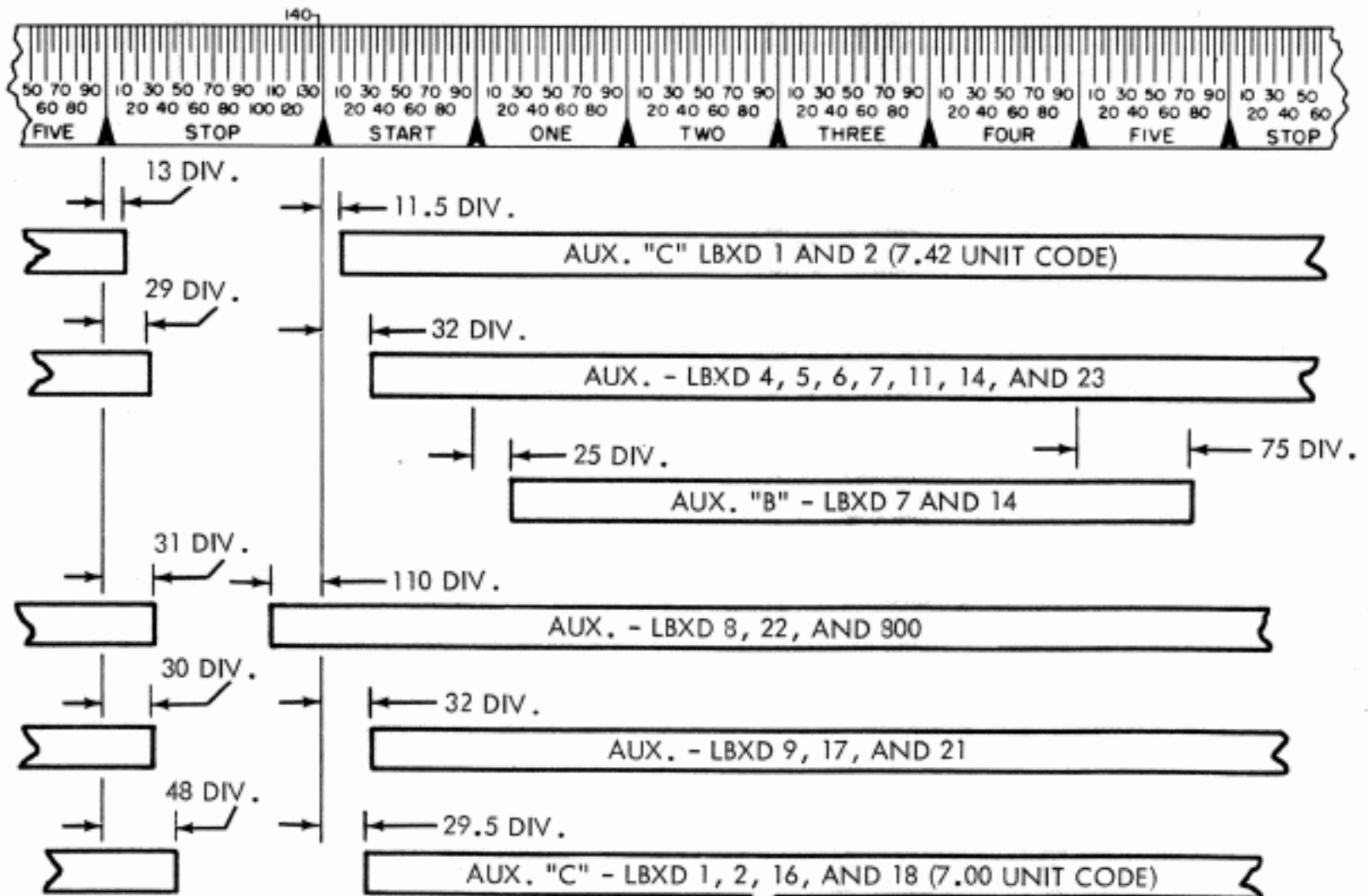

FIGURE 7. DISTRIBUTOR AUXILIARY CONTACT REQUIREMENTS

(4) Transmitter Contacts - 5 and 8 Level Unit (See Figure 3)

(a) Preliminary

1. Test set connected to the output of the distributor contacts.
2. Insert a "letters" perforated tape into the transmitter distributor sensing head. Align the end of the distributor stop pulse image with the 142 scale division on the stop segment of the test set scale.
3. Connect the input of the test set to the respective contact of the storing switch.

NOTE

LBXD 1, 2, and 11 - Contact #1 through #5 shall have no electrical breaks during the transmitted (distributor) code pulses. (Any electrical breaks occurring within the $\pm 3\%$ tolerance limits of the distributor contacts are acceptable). When reading successive marking code perforations, the time of contact opening shall not exceed 1.5 ms.

LBXD 4, 5, 6, 7, 14, 23, and 800 - Contacts #1 through #5 (or #0 through #7) shall have no electrical breaks during the transmitted (distributor) code pulses (see Tables 1 & 2 for transition points) greater than 2-1/2 scale divisions at 600 and 636 OPM, 2 scale divisions at 428 and 460 OPM, and 1-1/2 scale divisions at 368 and 390 OPM. No more than one break is permissible.

LBXD 8, 9, 16, 17, 18, 21, and 22 - Contacts #1 through #5 shall have no electrical breaks during the transmitted (distributor) code pulses. Any electrical breaks occurring within the $\pm 3\%$ tolerance limits of the distributor contacts or in the transition area are acceptable.

- (b) Requirement - LBXD 1, 2, 5, 6, 7, 8, 9, 11, 14, 16, 17, 21, 22, and 800 (7.42, 750 and 11.00 unit code)
 The beginning and end of each contact trace shall occur:
 Before 80 divisions in start segment
 After 20 divisions in stop segment

To Adjust

Position respective contact adjusting screw, or refine transfer contact adjustments as necessary.

NOTE

Beginning and end of pulse image may overlap within transition area.

- (c) Requirement - LBXD 1, 2, 11, 16, and 18 (7.00 unit code)
 The beginning and end of each contact trace shall occur:
 Before 26 divisions in start segment
 After 56 divisions in stop segment

To Adjust

Position respective contact adjusting screw, or refine transfer contact adjustments as necessary.

NOTE

Beginning and end of pulse image may overlap within transition area.

- (d) Requirement - LBXD 4, 6, and 23 (7.42 unit code)
At 600 OPM
 The beginning and end of each contact trace shall occur:
 Before 30 divisions in start segment
 After 40 divisions in stop segment

At 460 OPM

The beginning and end of each contact trace shall occur:
 Before 45 divisions in start segment
 After 31 divisions in stop segment

At 368 OPM

The beginning and end of each contact trace shall occur:
 Before 55 divisions in start segment
 After 25 divisions in stop segment

To Adjust

Position respective contact adjusting screw, or refine transfer contact adjustments as necessary.

NOTE

Beginning and end of pulse image may overlap within transition area.

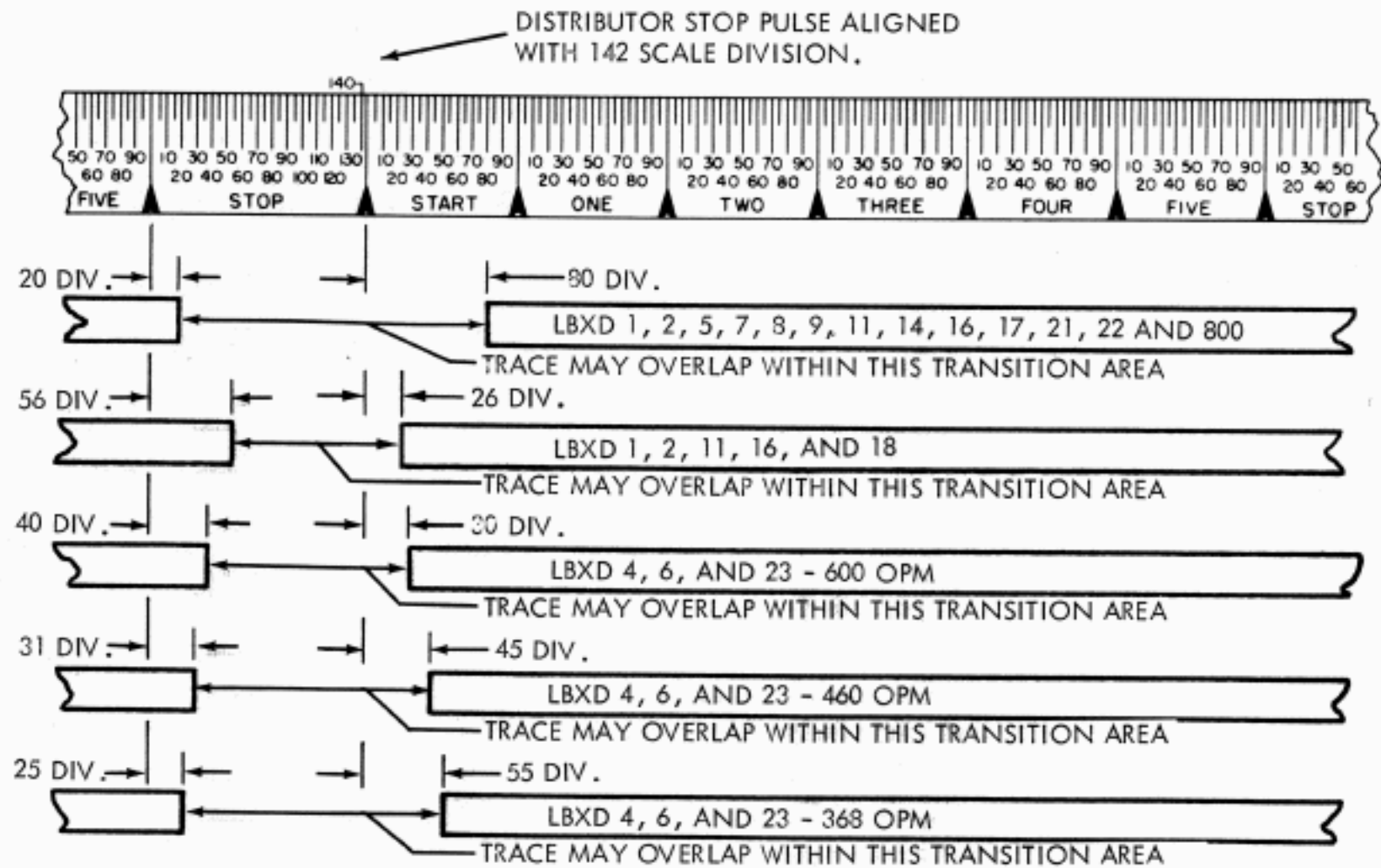

FIGURE 8. TRANSMITTER CONTACT REQUIREMENTS

(5) Transmitter Auxiliary Contacts (Make-Only Type)

(a) Preliminary

1. Both magnets de-energized, distributor and transmitter shaft clutches latched and in the stop position. Turn motor off.
2. Hold distributor and transmitter shaft gears against rotation. Energize both clutch trip magnets.
3. Release gears and turn motor on.
4. Align the end of the distributor stop pulse image with the 142 scale division on the stop segment of the test set scale.

(d) Requirements LBXD 1, 2, and 11 (7.00 unit code) - See Figure 11

1. Requirement - Auxiliary "A" Contact
Auxiliary "A" contact should:
Close at $90 + 8$ divisions in #5 segment
Open at 36.5 ± 20 divisions in #1 segment
2. Requirement - Auxiliary "B" Contact
Auxiliary "B" contact should:
Close at $83 + 12$ divisions in start segment
Open at 33.5 ± 8 divisions in #4 segment

To Adjust
Position respective contact adjusting screws as necessary.

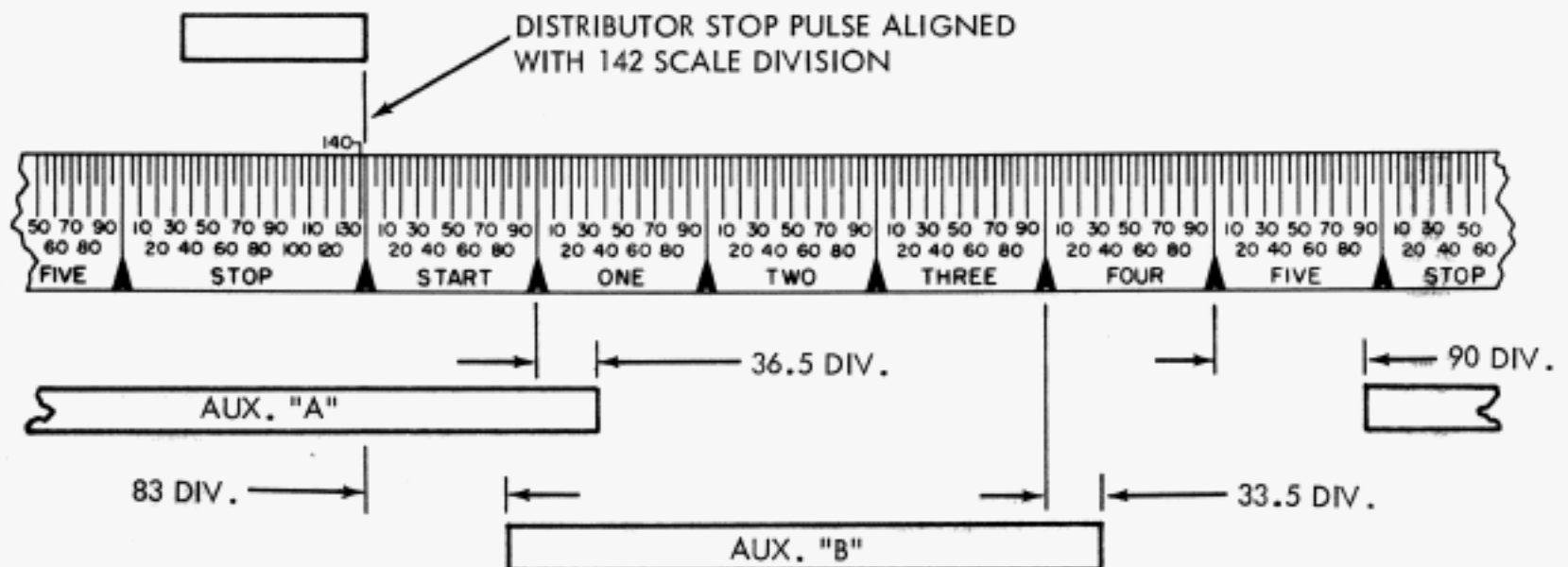
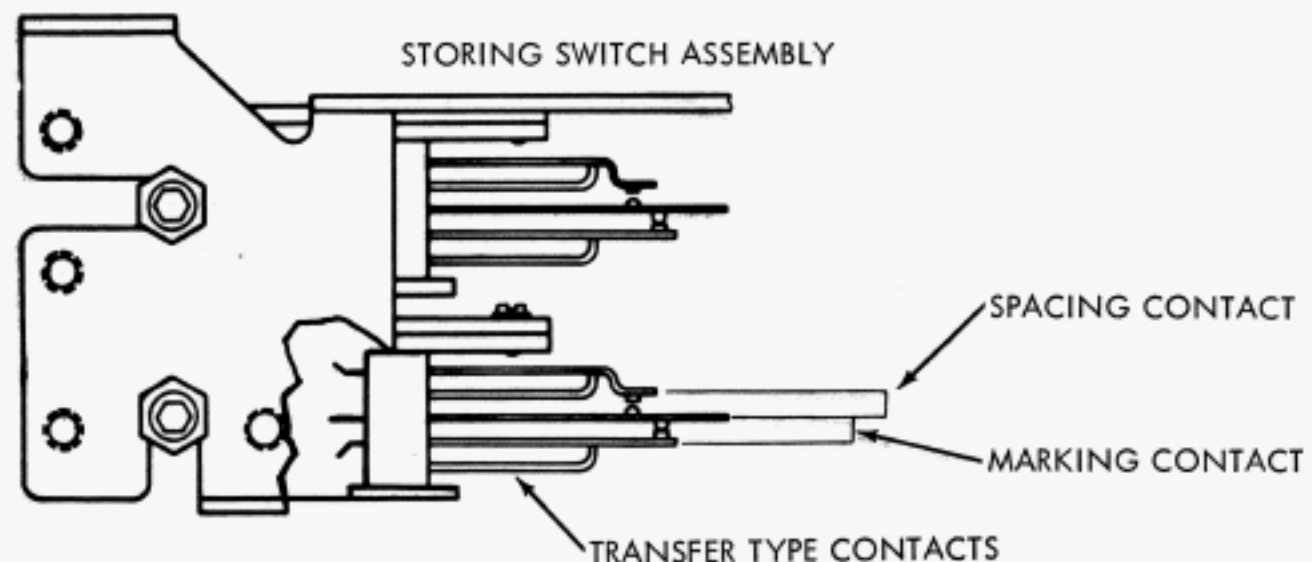

FIGURE 11. LBXD 1, 2, AND 11 TRANSMITTER AUXILIARY CONTACT REQUIREMENTS

(6) Transmitter Auxiliary Contacts (Transfer Type)

(a) Preliminary

1. Refer to paragraph 4.b.(5)(a) 1. through 4.
2. In the following requirements, reference is made to "marking contacts" and "spacing contacts". The figure below explains which contacts are being referred to.



(b) Requirements - LBXD 8, 22, and 800 (7.42 unit code) - See Figure 12

1. Clutch Trip Contacts
Requirement - Marking Contacts
Contacts should:
Close at $90 + 10$ divisions in start segment
Open at 64 ± 20 divisions in #2 segment

Requirement - Spacing Contacts

Contacts should:

Open at $80 + 10$ divisions in start segmentClose at $74 + 20$ divisions in #2 segment.

To Adjust

Refine transfer contact adjustments as necessary.

2. Auxiliary Contacts

Requirement - Marking Contacts

Contacts should:

Close at $80 + 10$ divisions in #2 segmentOpen at $31 + 20$ divisions in stop segment

Requirement - Spacing Contacts

Contacts should:

Open at $72 + 10$ divisions in #2 segmentClose at $41 + 20$ divisions in stop segment

To Adjust

Refine transfer contact adjustments as necessary.

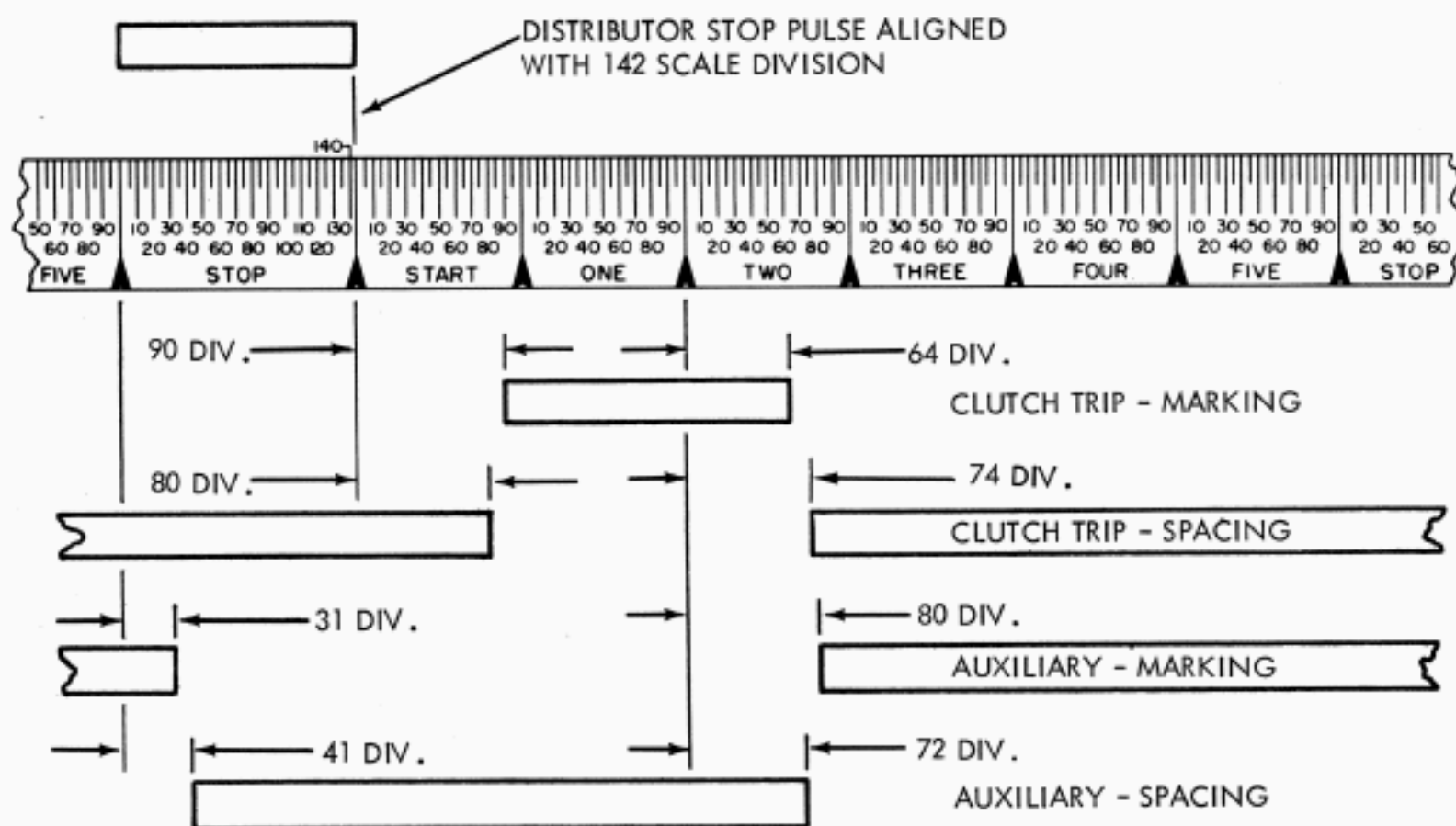

FIGURE 12. LBXD 8, 22, AND 800 TRANSMITTER AUXILIARY CONTACT REQUIREMENTS

(c) Requirements - LBXD 9 (7.42 unit code) - See Figure 13

1. Auxiliary "A" Contacts

Requirement - Marking Contacts

Contacts should:

Close at $50 + 10$ divisions in stop segmentOpen at $85 + 10$ divisions in stop segment

Requirement - Spacing Contacts

Contacts should:

Open at $36 + 20$ divisions in stop segmentClose at $106 + 20$ divisions in stop segment

To Adjust

Refine transfer contact adjustments as necessary.

2. Auxiliary "B" Contacts

Requirement - Marking Contacts

Contacts should:

Close at $30 + 10$ divisions in #4 segment

Open at 70 ± 20 divisions in #5 segment

Requirement - Spacing Contacts

Contacts should:

Open at 20 ± 10 divisions in #4 segment.

Close at 80 ± 20 divisions in #5 segment.

To Adjust

Refine transfer contact adjustments as necessary.

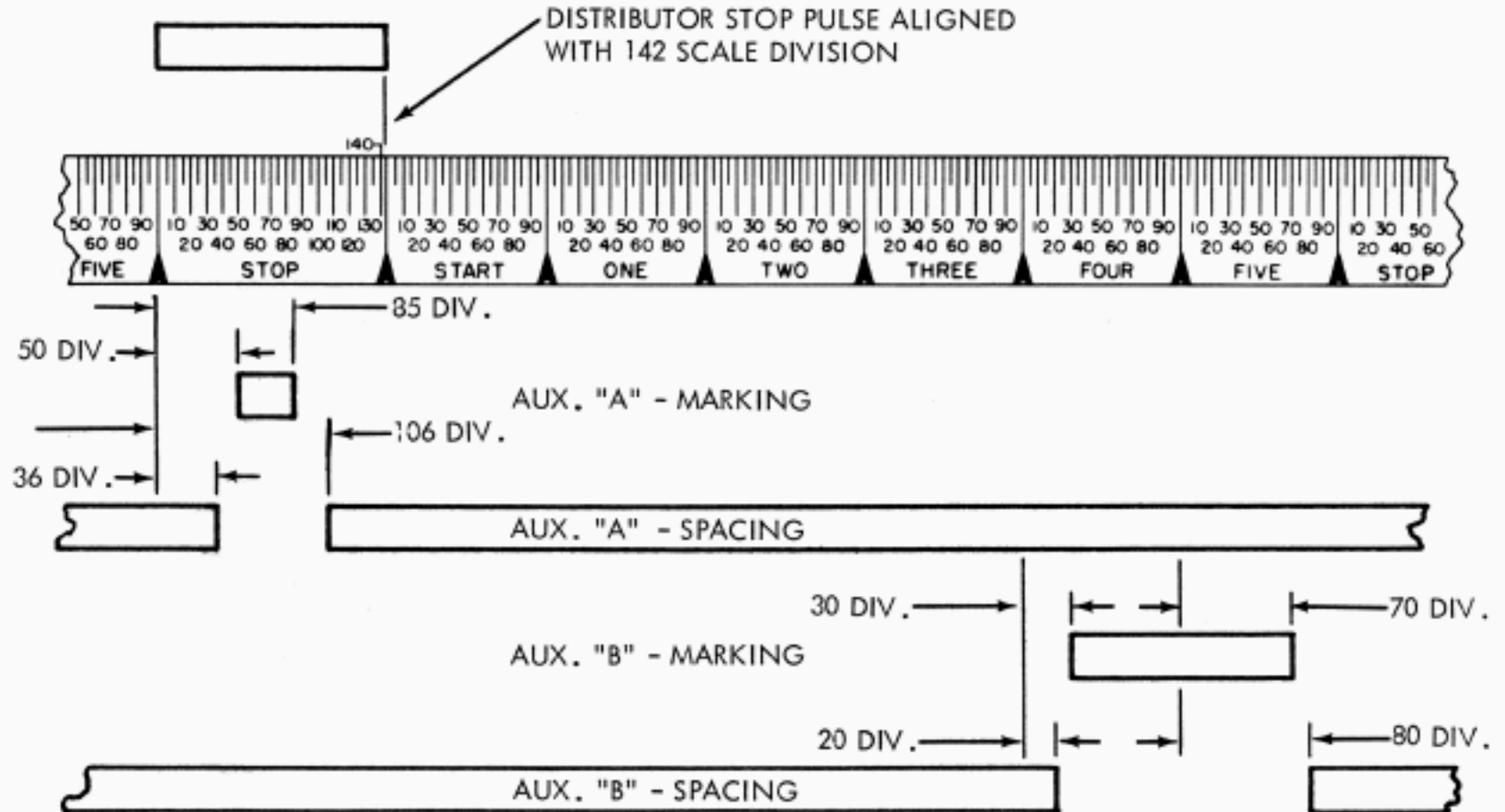

FIGURE 13. LBXD 9 TRANSMITTER AUXILIARY CONTACT REQUIREMENTS

(d) Requirements - LBXD 16 (7.00 unit code) - See Figure 14

1. Auxiliary "A" Contacts

Requirement - Marking Contacts

Contacts should:

Open at $70.5 + 10$ divisions in start segment

Close at 90 ± 20 divisions in #5 segment

Requirement - Spacing Contacts

Close at $80.5 + 10$ divisions in start segment

Open at 80 ± 20 divisions in #5 segment

To Adjust

Refine transfer contact adjustments as necessary.

2. Auxiliary "B" Contacts

Requirement - Marking Contacts

Contacts should:

Open at $6 + 10$ divisions in stop segment

Close at 83 ± 20 divisions in start segment

Requirement - Spacing Contacts

Contacts should:

Close at 16 ± 10 divisions in stop segmentOpen at 73 ± 20 divisions in start segment

To Adjust

Refine transfer contact adjustments as necessary.

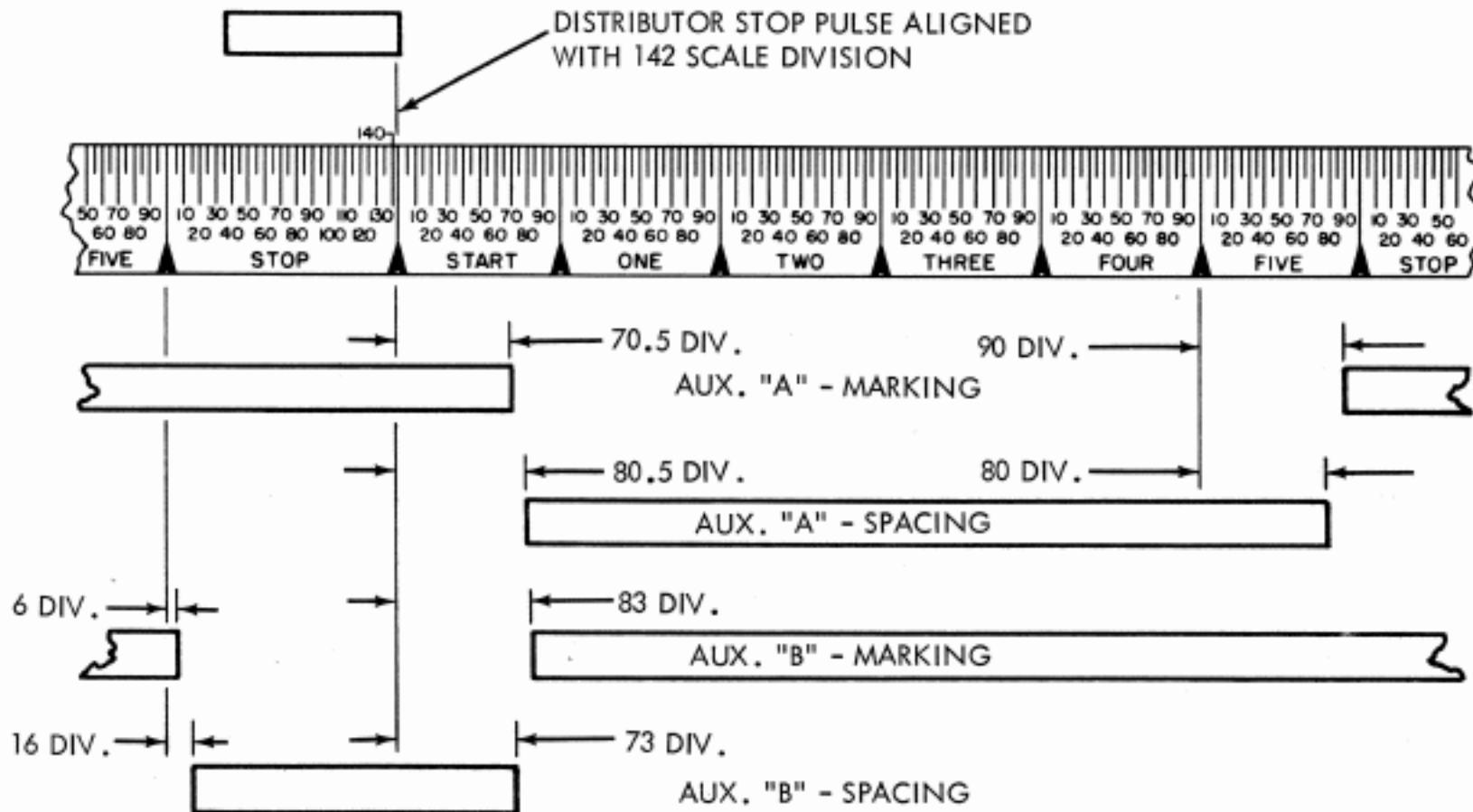

FIGURE 14. LBXD16 TRANSMITTER AUXILIARY CONTACT REQUIREMENTS

(e) Requirements - LBXD 18 (7.00 unit code) - See Figure 15

1. Auxiliary "A" Contacts

Requirement - Marking Contacts

Contacts should:

Close at 68 ± 10 divisions in stop segmentOpen at 103 ± 10 divisions in stop segment

Requirement - Spacing Contacts

Contacts should:

Open at 54 ± 20 divisions in stop segmentClose at 124 ± 20 divisions in stop segment

To Adjust

Refine transfer contact adjustments as necessary.

2. Auxiliary "B" Contacts

Requirement - Marking Contacts

Contacts should:

Close at 48 ± 10 divisions in #4 segmentOpen at 68 ± 20 divisions in #5 segment

Requirement - Spacing Contacts

Contacts should:

Open at 38 ± 10 divisions in #4 segmentClose at 98 ± 20 divisions in #5 segment

To Adjust

Refine transfer contact adjustments as necessary.

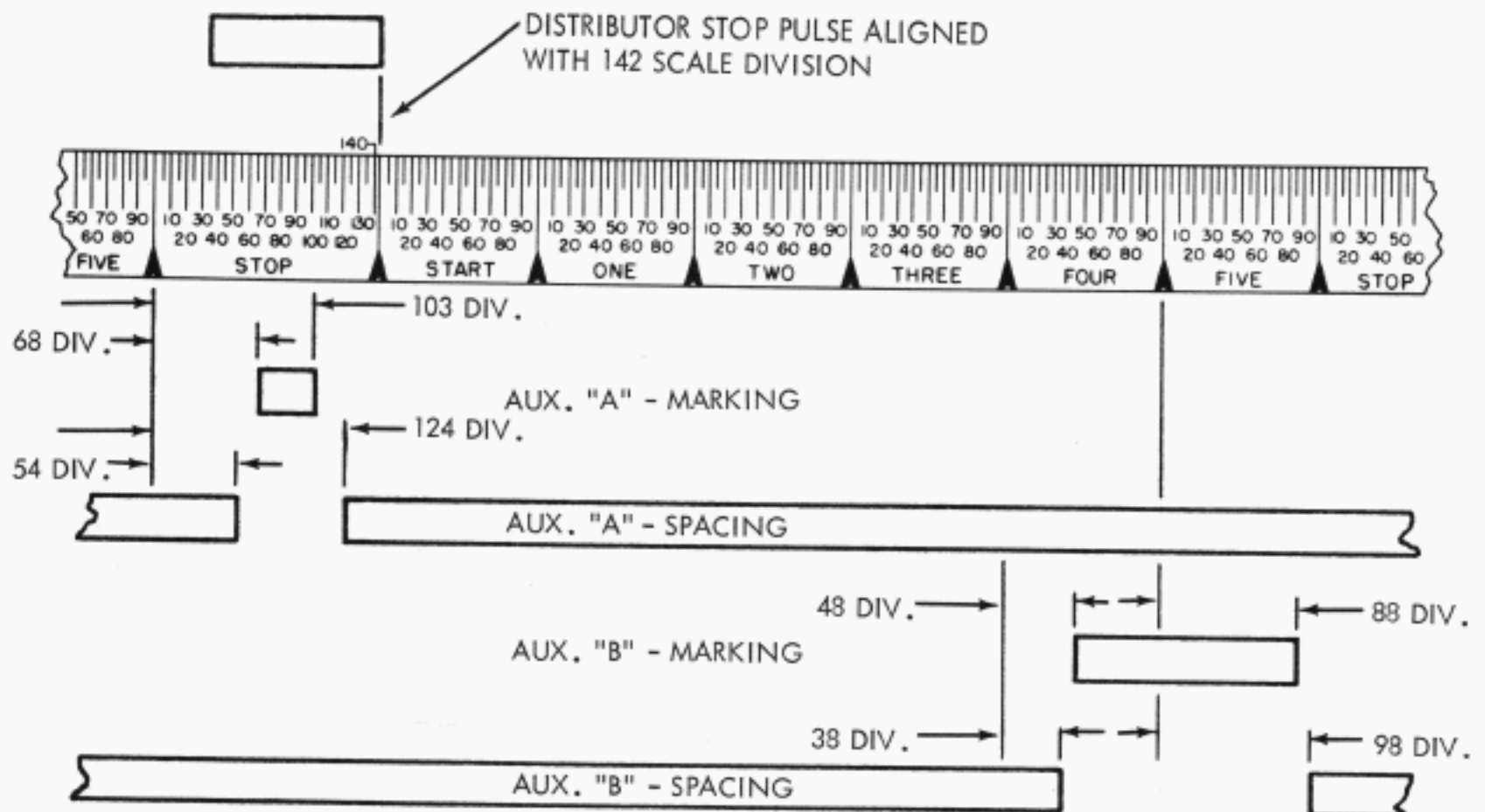

FIGURE 15. LBXD18 TRANSMITTER AUXILIARY CONTACT REQUIREMENTS

(f) Requirements - LBXD 17 and 21 (7.50 unit code)- See Figure 16

1. Auxiliary "A" Contact

Requirement - Marking Contacts

Contacts should:

Close at 48 ± 10 divisions in stop segment

Open at 82 ± 10 divisions in stop segment

Requirement - Spacing Contacts

Contacts should:

Open at $33 + 20$ divisions in stop segment

Close at $103 + 20$ divisions in stop segment

To Adjust

Refine transfer contact adjustments as necessary.

2. Auxiliary "B" Contacts

Requirement - Marking Contacts

Contacts should:

Close at $27 + 10$ divisions in #4 segment

Open at 67 ± 20 divisions in #5 segment

Requirement - Spacing Contacts

Contacts should:

Open at $17 + 10$ divisions in #4 segment

Close at 77 ± 20 divisions in #5 segment

To Adjust

Refine transfer contact adjustments as necessary.

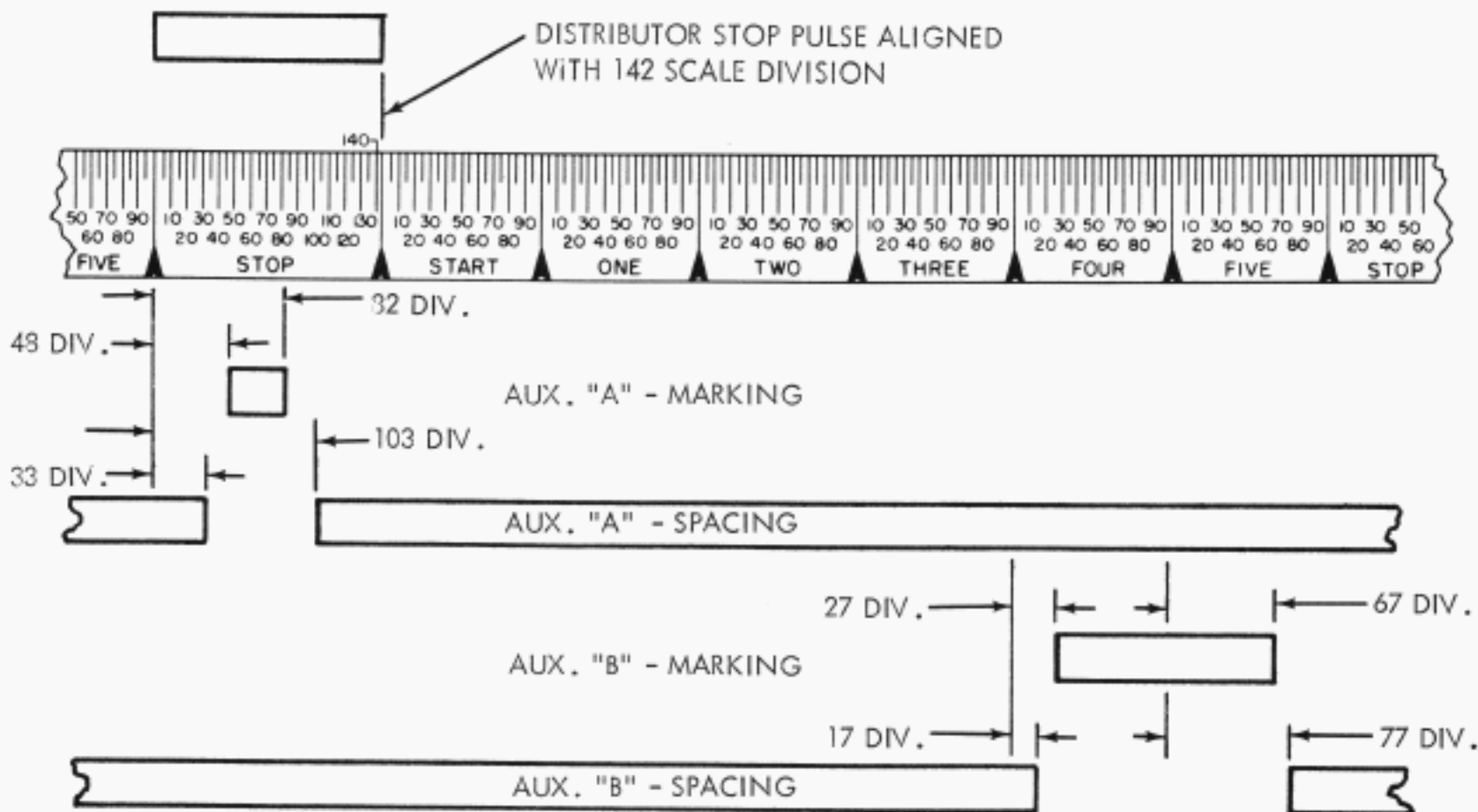

FIGURE 16. LBDX 17 AND 21 TRANSMITTER AUXILIARY CONTACT REQUIREMENTS

c. CONTACT STROBING PROCEDURE - 2 CYCLE CAM (LBDX 19)

NOTE

To strobe a transmitter distributor operating at 1200 OPM (200 WPM), replace the test set 1 cycle measuring scale with a 2 cycle scale. Refer to Bulletin 181B and 261B respectively, for 200 WPM operation of the DXD or LSS test sets (not all LSS test sets require a measuring scale change in order to strobe units operating at 200 WPM).

(1) Distributor Contacts - #1 through #5

- (a) Adjust the stop pulse length as outlined in paragraph 4.b.(1)(a) and (b). For 1200 OPM operation, stop pulse length variation is $\pm 5\%$.
- (b) Replace the "blank" perforated tape with an "R" perforated tape. Align the ends of the stop pulse images with the 142 scale divisions on the stop segments of the test set scale. Adjust the #2 and #4 contact adjusting screws as outlined in paragraph 4.b.(1)(c), allowing $\pm 5\%$ pulse length variation.
- (c) Replace the "R" perforated tape with a "Y" perforated tape. Align the ends of the stop pulse images with the 142 scale divisions on the stop segments of the test set scale. Adjust the #1, #3, and #5 contact adjusting screws as outlined in paragraph 4.b.(1)(d), allowing $\pm 5\%$ pulse length variation.

NOTE

To determine the end of the number 5 pulse image, it may be necessary to hold the stop contact open.

(2) Distributor Auxiliary "C" Contact (See Figure 17.)

Align the end of the stop pulse image with the 142 scale division on the stop segment of the test scale.

Requirement

Auxiliary "C" contact should:

Close at $34 + 15$ divisions in start segment

Open at 28 ± 15 divisions in stop segment

To Adjust

Rotate auxiliary contact screw to meet requirement.

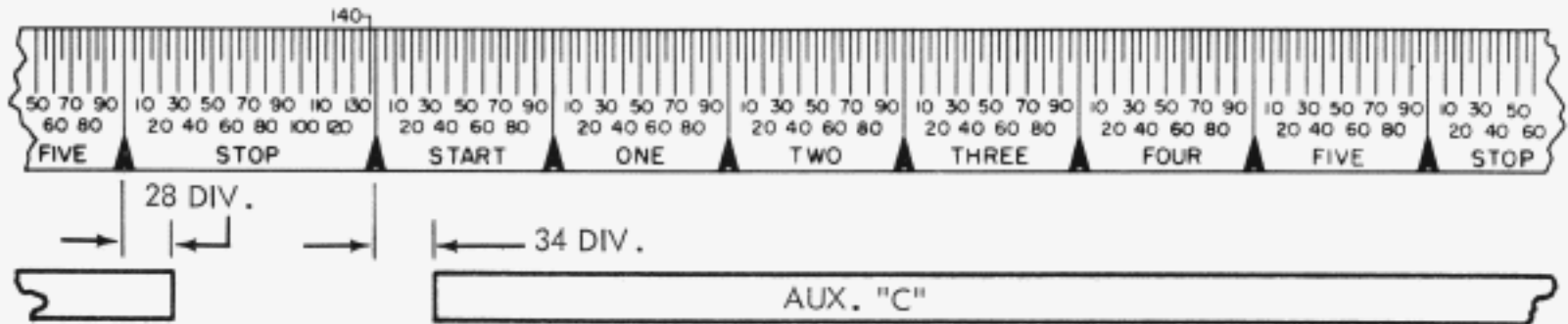

FIGURE 17. LBXD19 DISTRIBUTOR AUXILIARY CONTACT REQUIREMENTS -

(3) Transmitter Contacts - #1 through #5 (See Figure 18)

NOTE

Follow test procedure outlined in paragraph 4.b.(4)(a)1. through 3.

Requirement

The beginning and end of each contact trace shall occur:

Before 85 divisions in start segment

After 15 divisions in stop segment

To Adjust

Position respective contact adjusting screw as necessary.

NOTE

Beginning and end of pulse image may overlap within transition area.

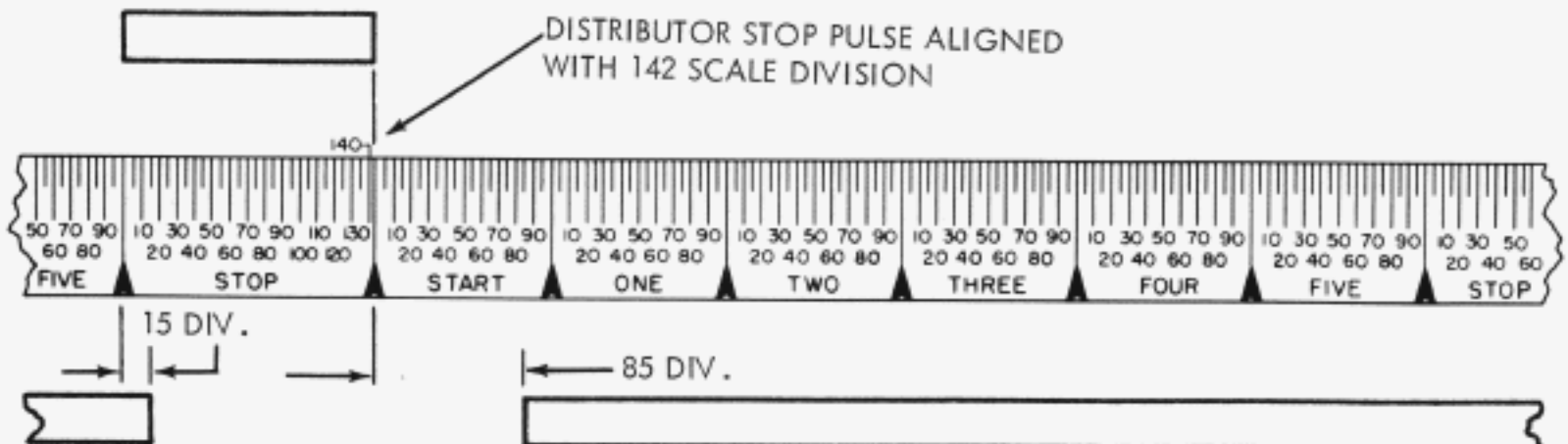

FIGURE 18. LBXD19 TRANSMITTER CONTACT REQUIREMENTS

(4) Transmitter Auxiliary Contacts (See Figure 19)

NOTE

Follow test procedure outlined in paragraph 4.b.(5)(a)1. through 4.

(a) Requirement - Auxiliary "A" Contact

Auxiliary "A" Contact should:

Close at $12.5 + 15$ divisions in start segment

Open at 26 ± 15 divisions in #4 segment.

- (b) Requirement - Auxiliary "B" contact
 Auxiliary "B" Contact should:
 Close at 4 ± 5 divisions in start segment
 Open at 66 ± 15 divisions in #2 Segment

To Adjust

Rotate auxiliary contact screws to meet requirements.

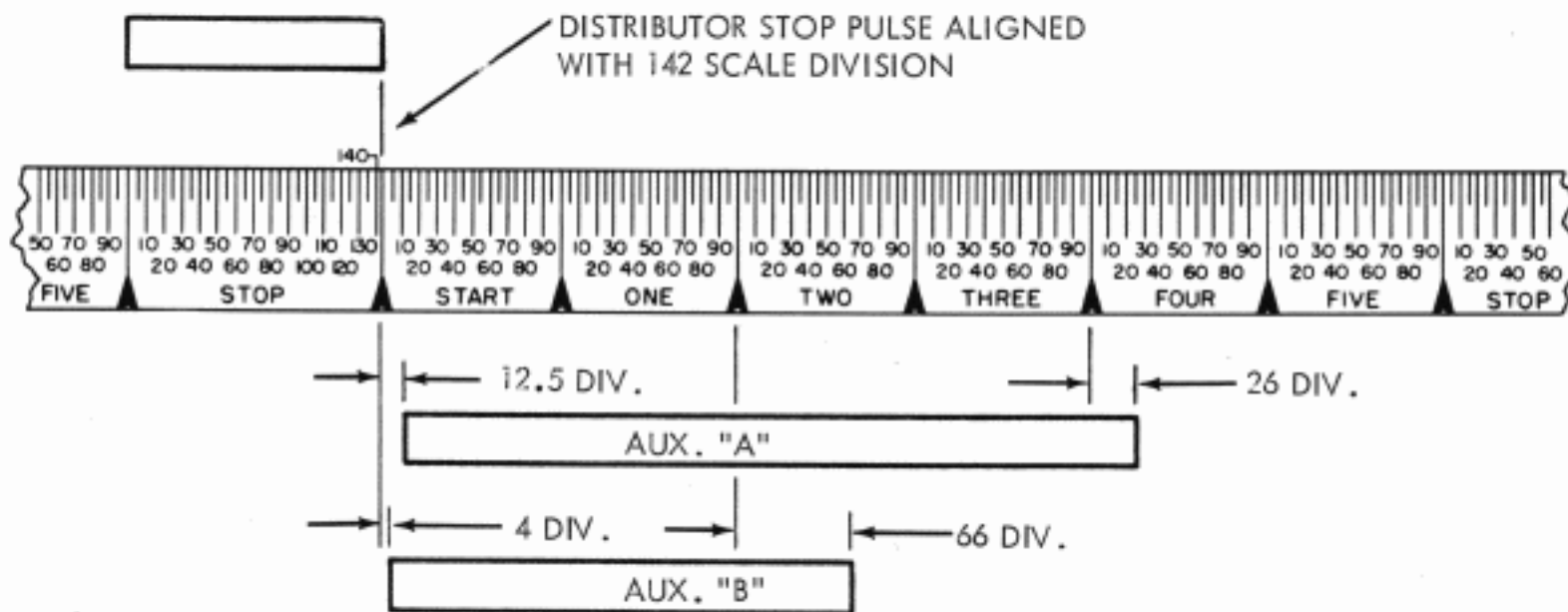

FIGURE 19. LBXD19 TRANSMITTER AUXILIARY CONTACT REQUIREMENTS

SECTION 2

VARIABLE FEATURE ADJUSTMENT

TAPE-OUT AND TAPE LID SWITCH

NOTE

MAKE THIS ADJUSTMENT BEFORE ASSEMBLING SWITCH TO UNIT.

- (1) REQUIREMENT
 MIN. 8 GRAMS
 MAX. 15 GRAMS
 TO JUST SEPARATE NORMALLY CLOSED CONTACTS (APPLY SCALE TO CENTER OF NYLON PAD).
 TO ADJUST
 BEND CONTACT SWINGER WITH A 110445 SPRING BENDER.
- (2) REQUIREMENT
 MIN. 0.008 INCH
 MAX. 0.015 INCH
 GAP BETWEEN NORMALLY OPEN CONTACTS.
 TO ADJUST
 BEND UPPER CONTACT LEAF WITH A 110445 SPRING BENDER.

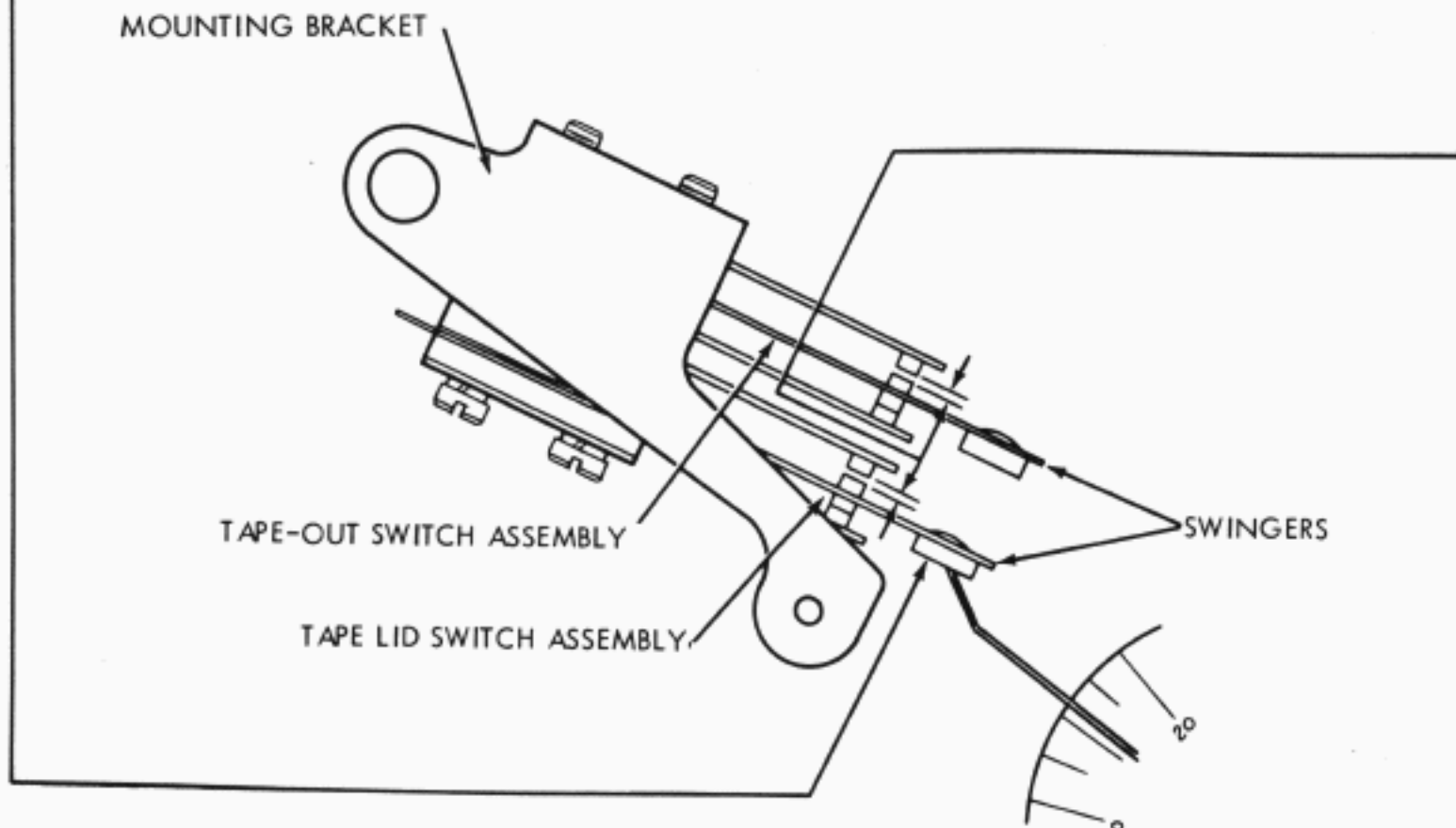

NOTE

TO REMOVE TAPE-OUT AND TAPE LID SWITCH ASSEMBLY

- (1) REMOVE COVER AND TOP PLATES.
- (2) REMOVE 111342 SPRING ATTACHED TO BRACKET ON 158535 GUIDE POST.
- (3) LOOSEN SCREW SECURING GUIDE POST TO REAR PLATE.
- (4) REMOVE SCREW AND LOCK WASHER FROM FRONT END OF GUIDE POST.
- (5) REMOVE ADJUSTING SCREW FROM LOWER END OF SWITCH BRACKET.
- (6) GUIDE POST AND SWITCH ASSEMBLY CAN NOW BE REMOVED. TAKE CARE NOT TO DISTORT SWITCH LEAF SPRINGS

TO REPLACE SWITCH ASSEMBLY

REVERSE DISASSEMBLY PROCEDURE.

FIGURE 2-1. TAPE-OUT AND TAPE LID SWITCH ASSEMBLY

(B) TAPE-OUT PIN SPRING BRACKET**REQUIREMENT**

MIN. 38 GRAMS

MAX. 45 GRAMS

TO DEPRESS TAPE-OUT PIN UNTIL FLUSH WITH TAPE GUIDE PLATE.

TO ADJUST

POSITION TAPE-OUT PIN SPRING BRACKET WITH ITS MOUNTING SCREWS FRICTION TIGHT. TIGHTEN SCREWS AND RECHECK REQUIREMENT.

(A) TAPE-OUT AND TAPE LID SWITCH BRACKET**REQUIREMENT**

MIN. 0.006 INCH

MAX. 0.020 INCH

CLEARANCE BETWEEN TAPE-OUT PIN EXTENSION AND CONTACT SWINGER INSULATOR WHEN TAPE-OUT PIN IS HELD DOWN.

TO ADJUST

INSERT A LENGTH OF UN-PERFORATED TAPE UNDER TAPE LID. ADJUST SWITCH BRACKET WITH ITS MOUNTING SCREW LOOSENED.

(C) TAPE-OUT AND TAPE LID PIN DOWNSTOP**REQUIREMENT**

WHEN DEPRESSED TO THEIR LOWERMOST POSITIONS, TAPE-OUT AND TAPE LID PINS SHOULD BE FLUSH TO 0.005 INCH BELOW SURFACE OF TAPE GUIDE PLATE.

TO ADJUST

POSITION RESPECTIVE DOWNSTOP POST WITH ITS MOUNTING NUT LOOSENED.

(D) TAPE LID PIN SPRING**REQUIREMENT**

MIN. 1-1/2 OZS.

MAX. 3 OZS.

TO MOVE TAPE LID PIN FLUSH WITH TOP SURFACE OF TOP PLATE.

(E) TAPE LID PIN**TO CHECK**

REMOVE COVER PLATE

(2) REQUIREMENT

WITH TAPE LID OPEN, AND NORMALLY OPEN CONTACTS CLOSED BY TAPE LID PIN:

MIN. 0.010 INCH

CLEARANCE BETWEEN SHOULDER ON PIN AND BOTTOM SURFACE OF TAPE GUIDE PLATE

(1) REQUIREMENT

WITH TAPE LID CLOSED:

MIN. 0.005 INCH

CLEARANCE BETWEEN TAPE LID PIN AND SWINGER INSULATOR.

TO ADJUST

LOOSEN CLAMP SCREW TO FRICTION TIGHT AND ADJUST TAPE LID PIN BY MEANS OF ITS PRY POINT.

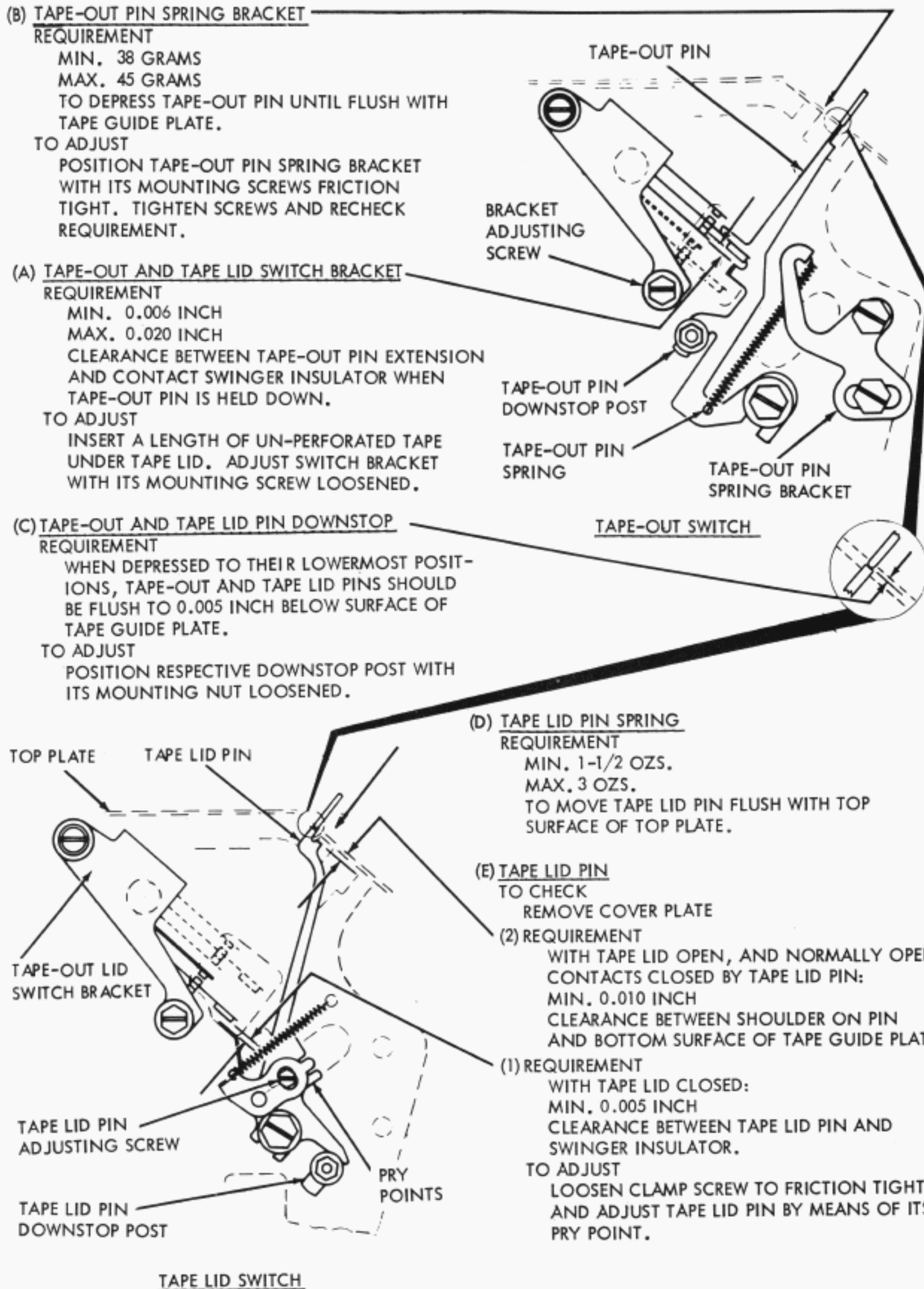

FIGURE 2-2. TAPE-OUT AND TAPE LID PIN MECHANISM

TAPE DEFLECTOR MECHANISM

NOTE

DEFLECTOR IS HINGED TO SWING IN EITHER OF TWO POSITIONS:

1. OPERATING POSITION (LEFT SIDE) - DEFLECTS TAPE BACK TO OPERATOR.
2. NON-OPERATING POSITION (RIGHT SIDE) - ALLOWS TAPE TO FOLLOW NORMAL PATH TO REAR OF UNIT.

(A) DEFLECTOR BRACKETREQUIREMENT

WHEN DEFLECTOR IS IN OPERATING POSITION, DEFLECTOR TANG SHALL BE CENTRALLY LOCATED IN TOP PLATE HOLE.

TO ADJUST

POSITION BRACKET WITH ITS MOUNTING SCREWS LOOSENED.

(B) DEFLECTOR SPRINGREQUIREMENT

MIN. 1-1/2 OZS.

MAX. 4 OZS.

TO START DEFLECTOR MOVING.

TO ADJUST

WITH SCREW WHICH ANCHORS SPRING TO FILLER PLATE LOOSENED, POSITION SPRING IN ITS ELONGATED MOUNTING SLOT. IF NECESSARY, BEND SPRING.

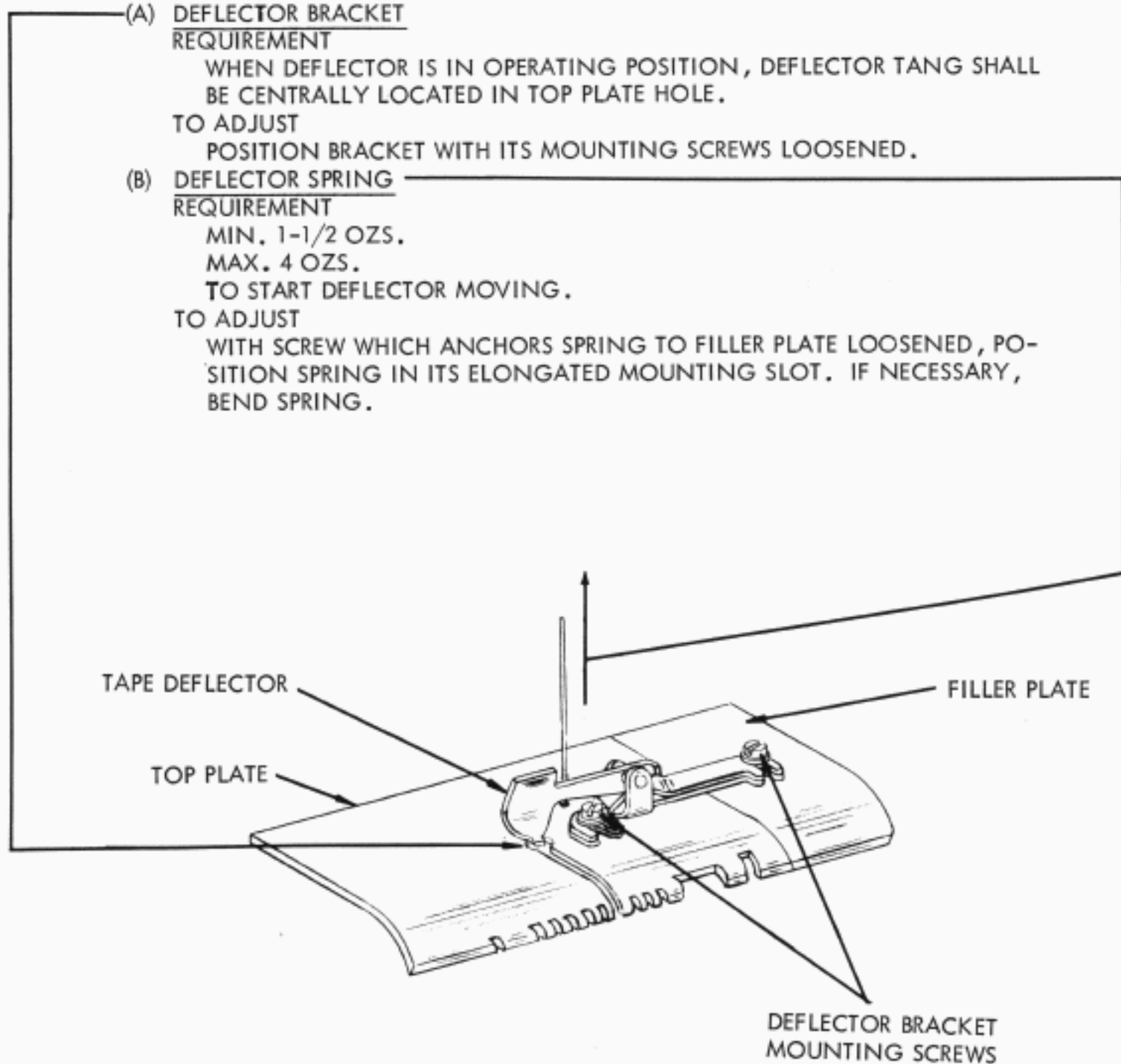

FIGURE 2-3. TAPE DEFLECTOR MECHANISM

LINE SHUNT SWITCH (160370)

TO CHECK

REMOVE UNIT FROM SUB-BASE.

- (1) REQUIREMENT
LINE SHUNT SWITCH CONTACTS SHOULD BE CLOSED.
- (2) REQUIREMENT
CLEARANCE BETWEEN ENGAGING SURFACE OF SWITCH PLUNGER AND ITS MOUNTING BRACKET:
MIN. 0.772 INCH
MAX. 0.802 INCH

TO ADJUST

POSITION SWITCH WITH ITS MOUNTING NUTS LOOSENED.

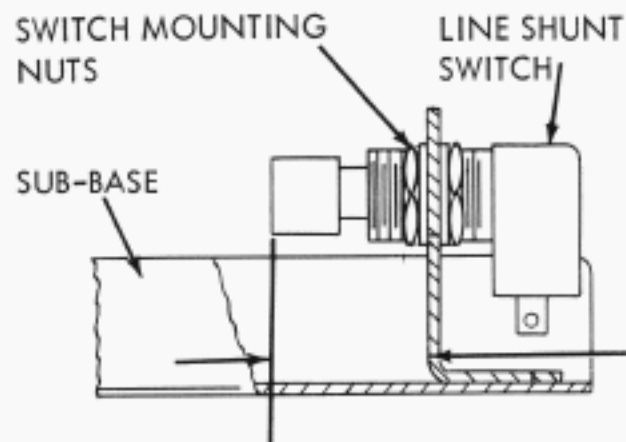
LINE SHUNT SWITCH (172847)

(1) REQUIREMENT

LINE SHUNT SWITCH CONTACTS OPEN WHEN TRANSMITTER DISTRIBUTOR LEFT REAR MOUNTING SCREW IS TIGHTENED.

(2) REQUIREMENT

LINE SHUNT SWITCH CONTACTS CLOSED WHEN LEFT REAR MOUNTING SCREW IS LOOSENED.

TO ADJUST

BACK OFF LEFT REAR MOUNTING SCREW 1/2 TURN. POSITION SWITCH ACTUATOR (SWITCH MOUNTING SCREWS FRICTION TIGHT) AGAINST THE TRANSMITTER MOUNTING SCREW UNTIL THE CONTACTS JUST CLOSE (SWITCH ACTUATOR SHOULD BE APPROXIMATELY HORIZONTAL). TIGHTEN SWITCH MOUNTING SCREWS. CHECK SWITCH OPERATION AND REFINE ADJUSTMENT IF NECESSARY.

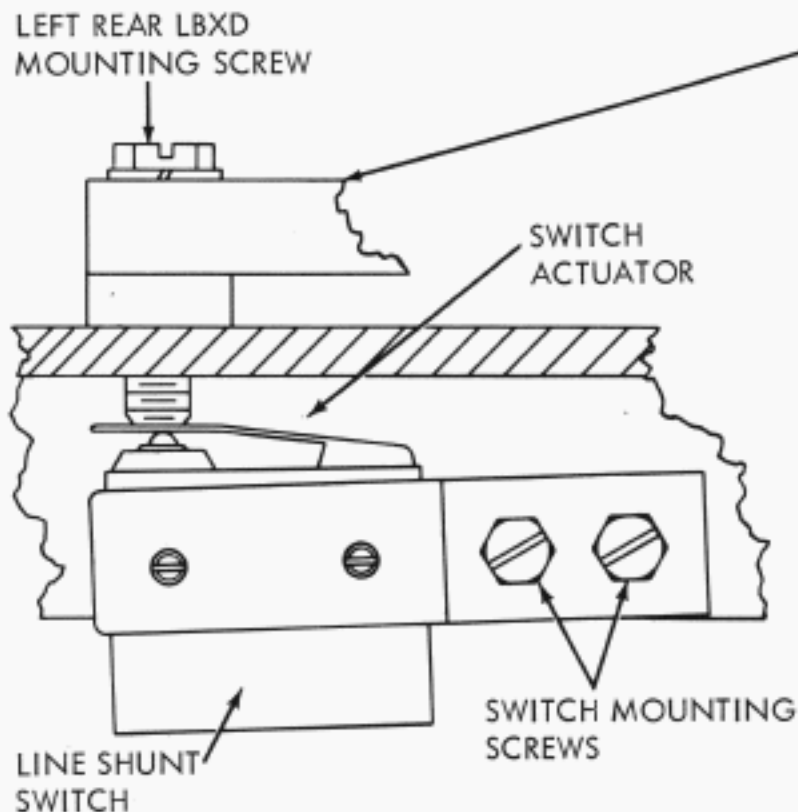
(A) LINE SHUNT SWITCH (MULTIPLE BASE)

TO CHECK

PLACE A TRANSMITTER DISTRIBUTOR IN ONE OF THE MOUNTING POSITIONS. NOTE THE POINT (A) AT WHICH THE CONNECTOR PLUG STARTS TO ENGAGE THE CONNECTOR RECEPTACLE, AND THE POINT (B) WHERE THE PLUG FULLY ENGAGES THE RECEPTACLE.

REQUIREMENT

LINE SWITCH SHALL ACTUATE (CONTACTS CLOSE) BEFORE UNIT IS WITHDRAWN ONE HALF THE DISTANCE BETWEEN POINTS (A) AND (B).

TO ADJUST

WITH SWITCH BRACKET MOUNTING SCREWS FRICTION TIGHT, POSITION SWITCH BY MEANS OF ITS PRY POINT. CHECK ALL LINE SHUNT SWITCHES.

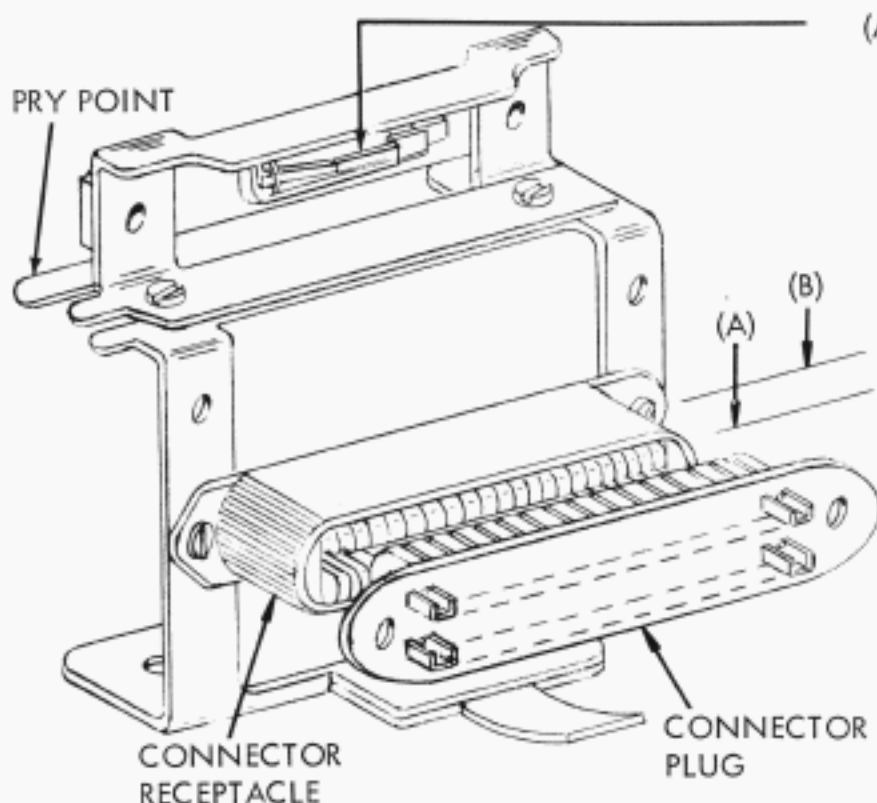

FIGURE 2-4. LINE SHUNT SWITCHES

SECTION 3
LUBRICATION

1. INTRODUCTION

a. This section provides lubrication information for the Teletype Model 28 (LBXD) Transmitter Distributor.

CAUTION

The transmitter distributor is shipped with the oil reservoir empty. Remove the cover plate for access to the reservoir. Fill the oil reservoir according to the lubrication instructions on page 3-6.

b. On the following pages, the general areas of the equipment are shown by photographs. The specific points to receive lubricant are indicated by line drawings and descriptive text. The symbols in the text indicate the following directions:

- O Apply one drop of oil.
- O2 Apply two drops of oil.
- O3 Apply three drops of oil, etc.
- G Apply thin coat of grease.
- SAT Saturate with oil (felt washers, etc.)

Teletype KS7470 oil and KS7471 grease should be used at all lubrication points.

2. GENERAL

a. The equipment should be thoroughly lubricated, but over-lubrication which might allow oil to drip or grease to be thrown on other parts, should be avoided. Exercise special care to prevent lubricant from getting between armature and pole faces. Keep all electrical contacts free from oil or grease.

b. The following general instructions supplement the specific lubricating points illustrated in this section.

- (1) Apply one drop of oil to all spring hooks.
- (2) Apply a light film of oil to all cam surfaces.
- (3) Apply a coat of grease to all gears.
- (4) Saturate all felt washers, oilers, etc.
- (5) Apply oil to all pivot points.
- (6) Apply oil to all sliding surfaces.

c. The transmitter distributor should be lubricated before being placed in service or prior to storage. After a few weeks of service, re-lubricate to make certain that all specified points have received lubricant. Thereafter, the following schedule should be adhered to:

<u>OPERATING SPEED</u>	<u>LUBRICATION INTERVAL</u>
60 W. P. M.	3000 hours or 1 year *
75 W. P. M.	2400 hours or 9 months *
100 W. P. M.	1500 hours or 6 months *

*Whichever occurs first.

3. LUBRICATION

a. TRANSMITTER DISTRIBUTOR

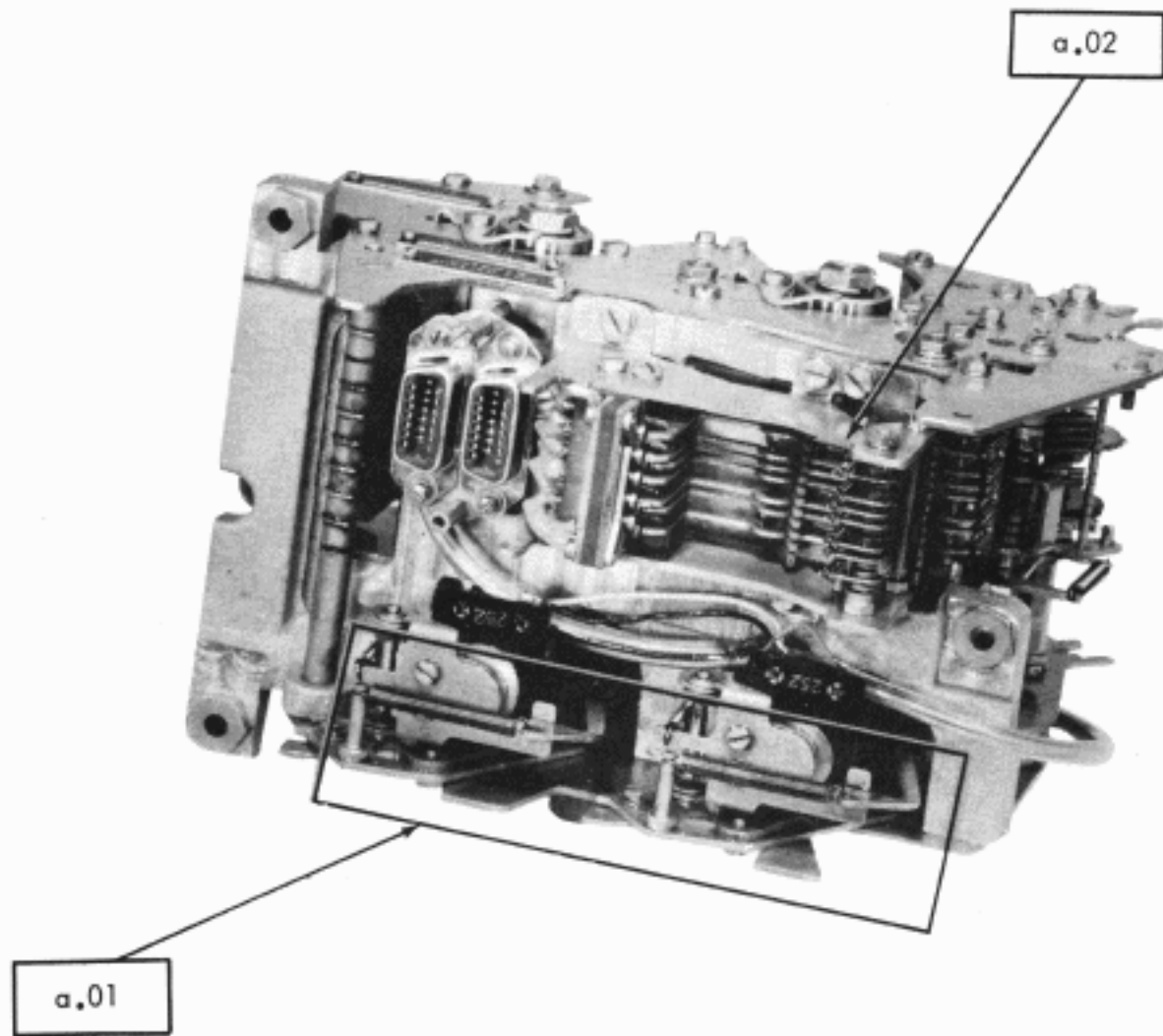

a.01 CLUTCH TRIP ASSEMBLIES

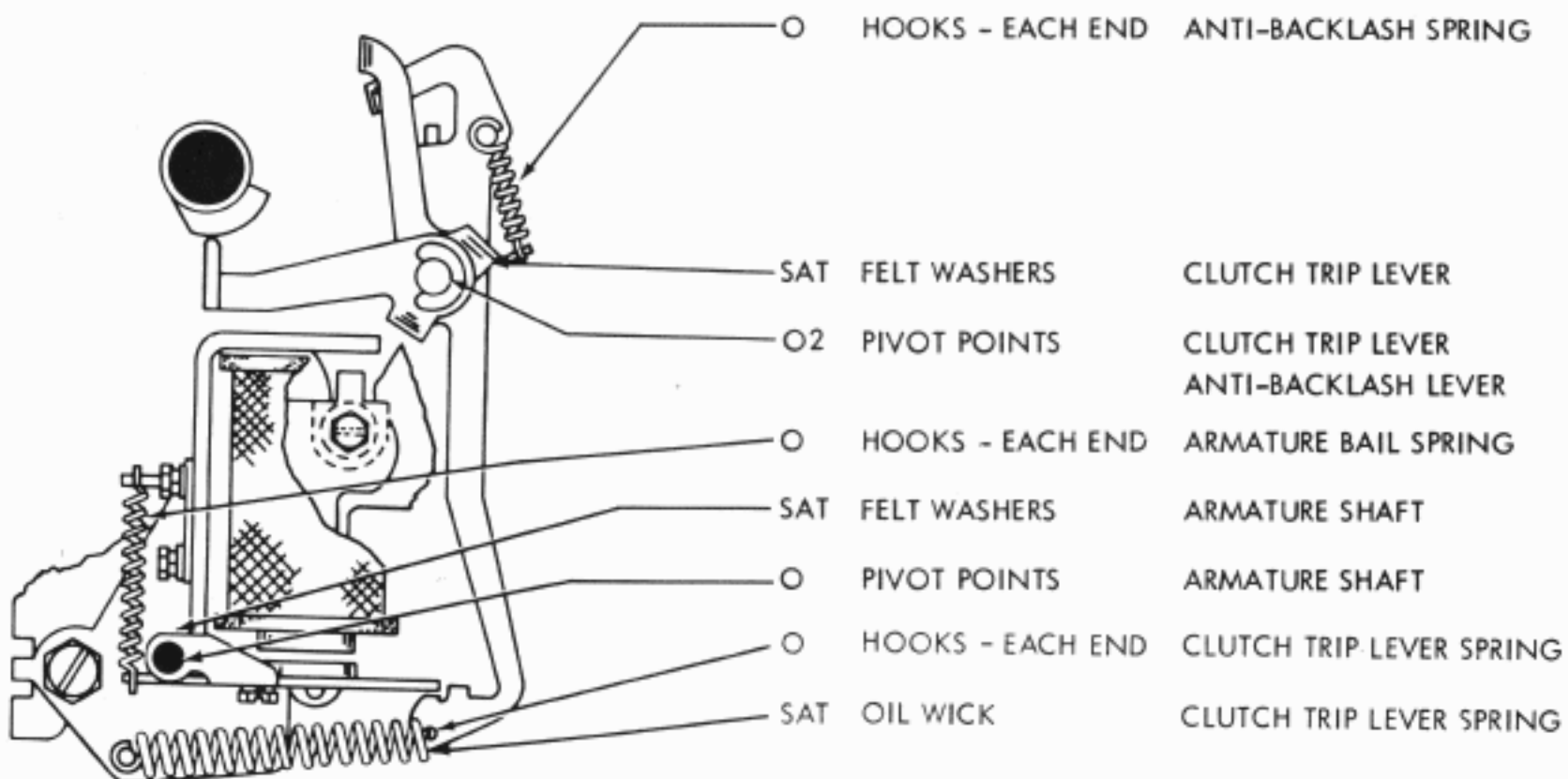

a.02 STORING SWITCH ASSEMBLIES

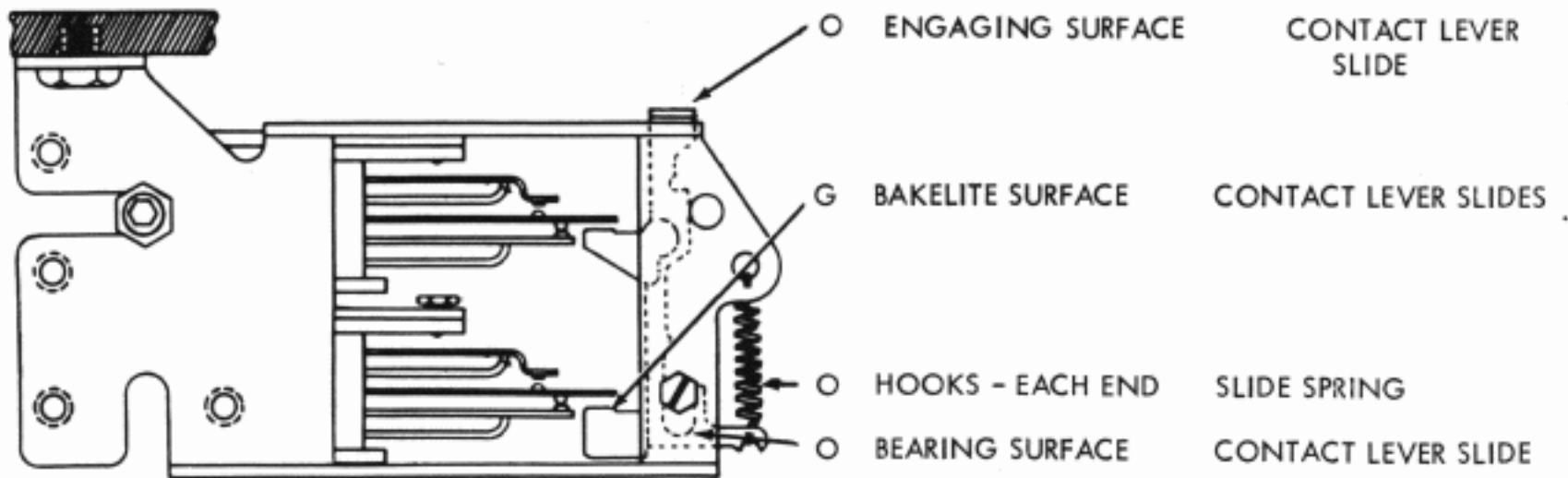
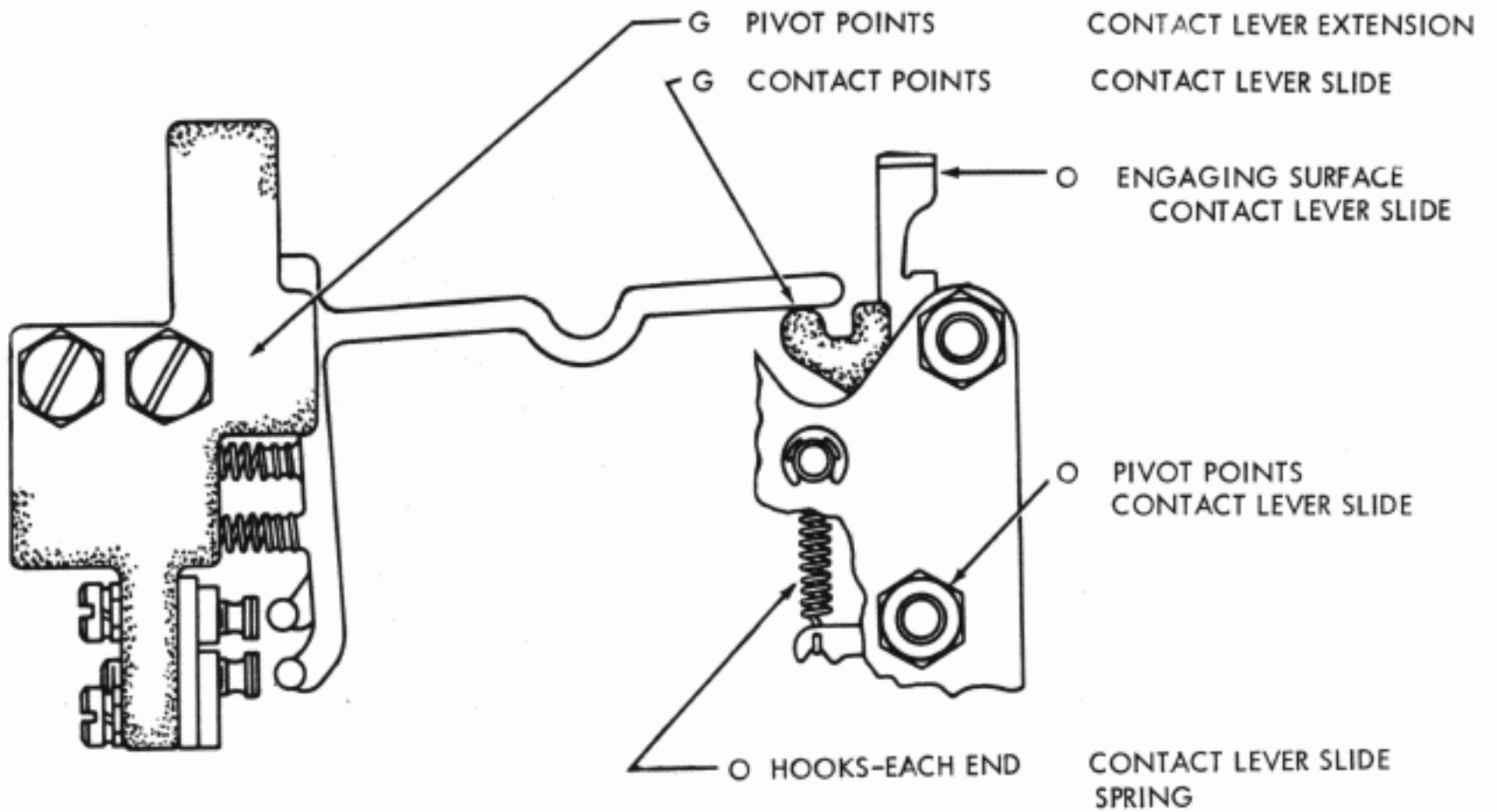

NOTE
KEEP CONTACTS FREE OF GREASE

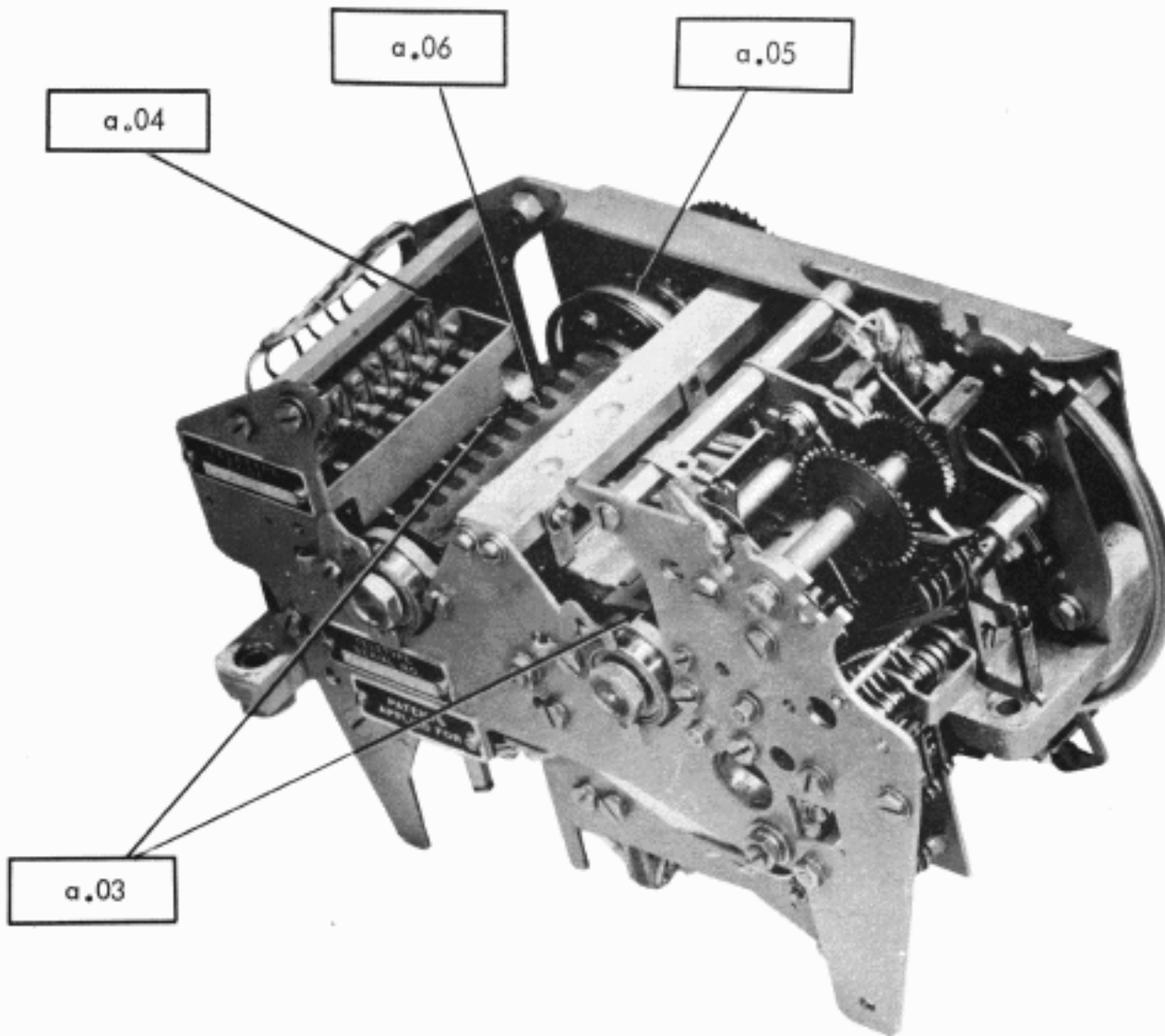

a.03 DISTRIBUTOR AND SENSING
SHAFT ASSEMBLIES

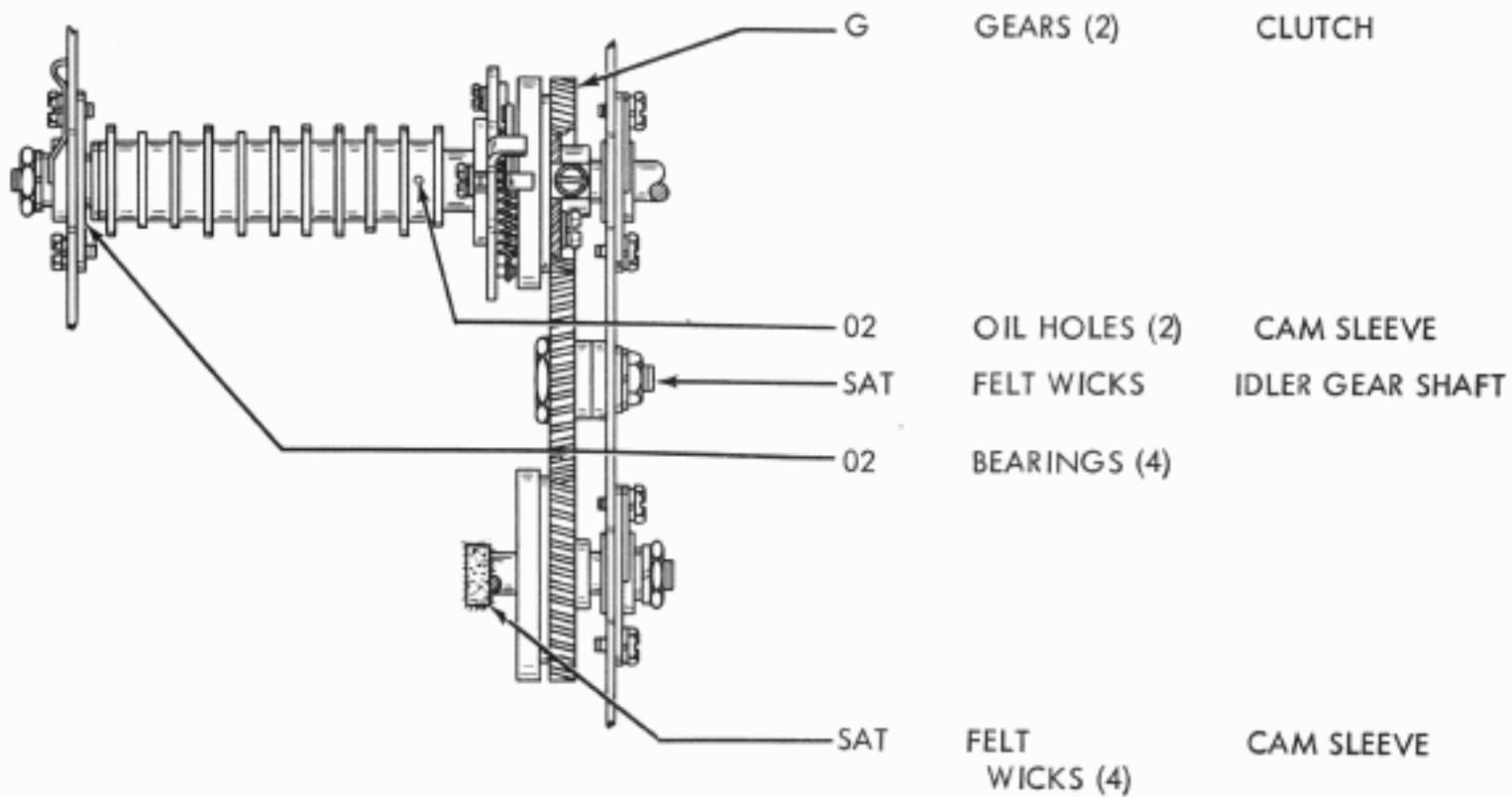

a.04 DISTRIBUTOR BLOCK ASSEMBLY

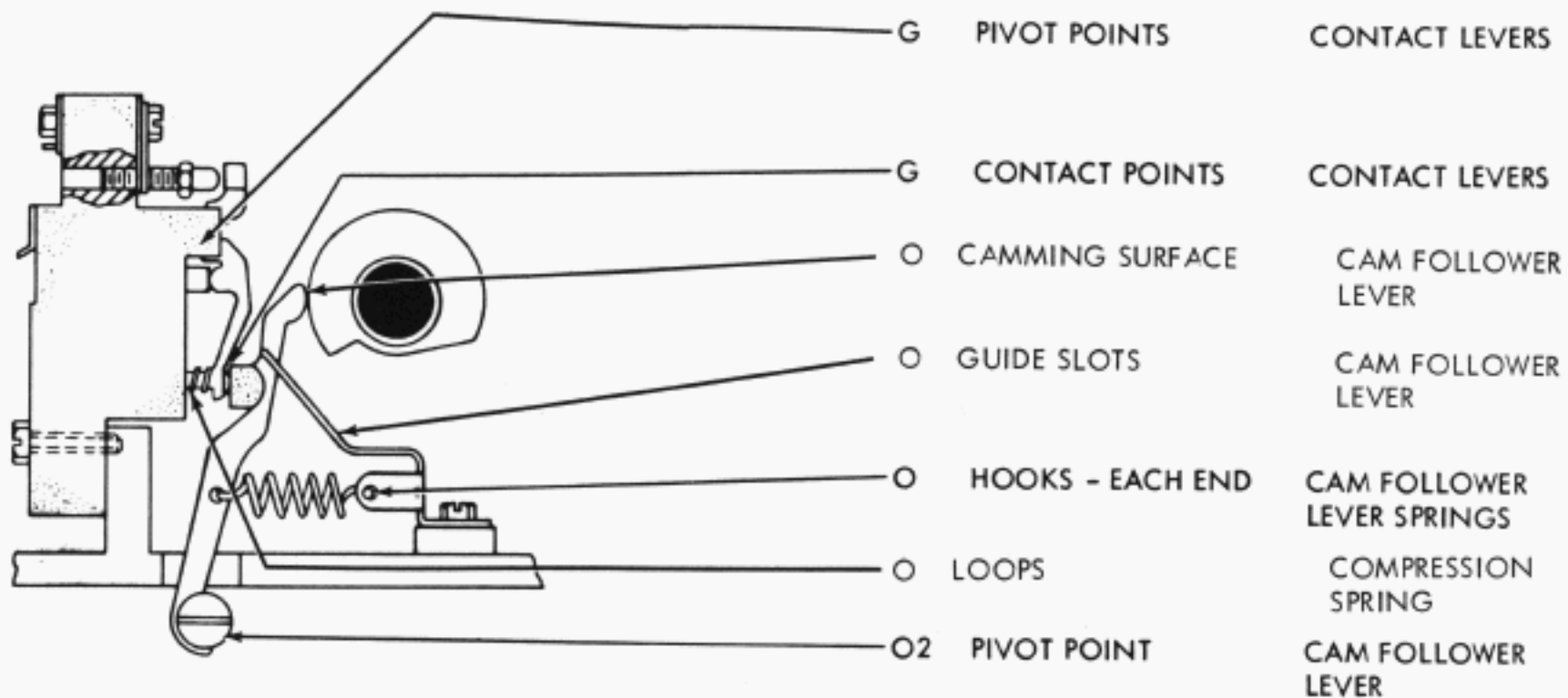

a.05 CLUTCH ASSEMBLIES

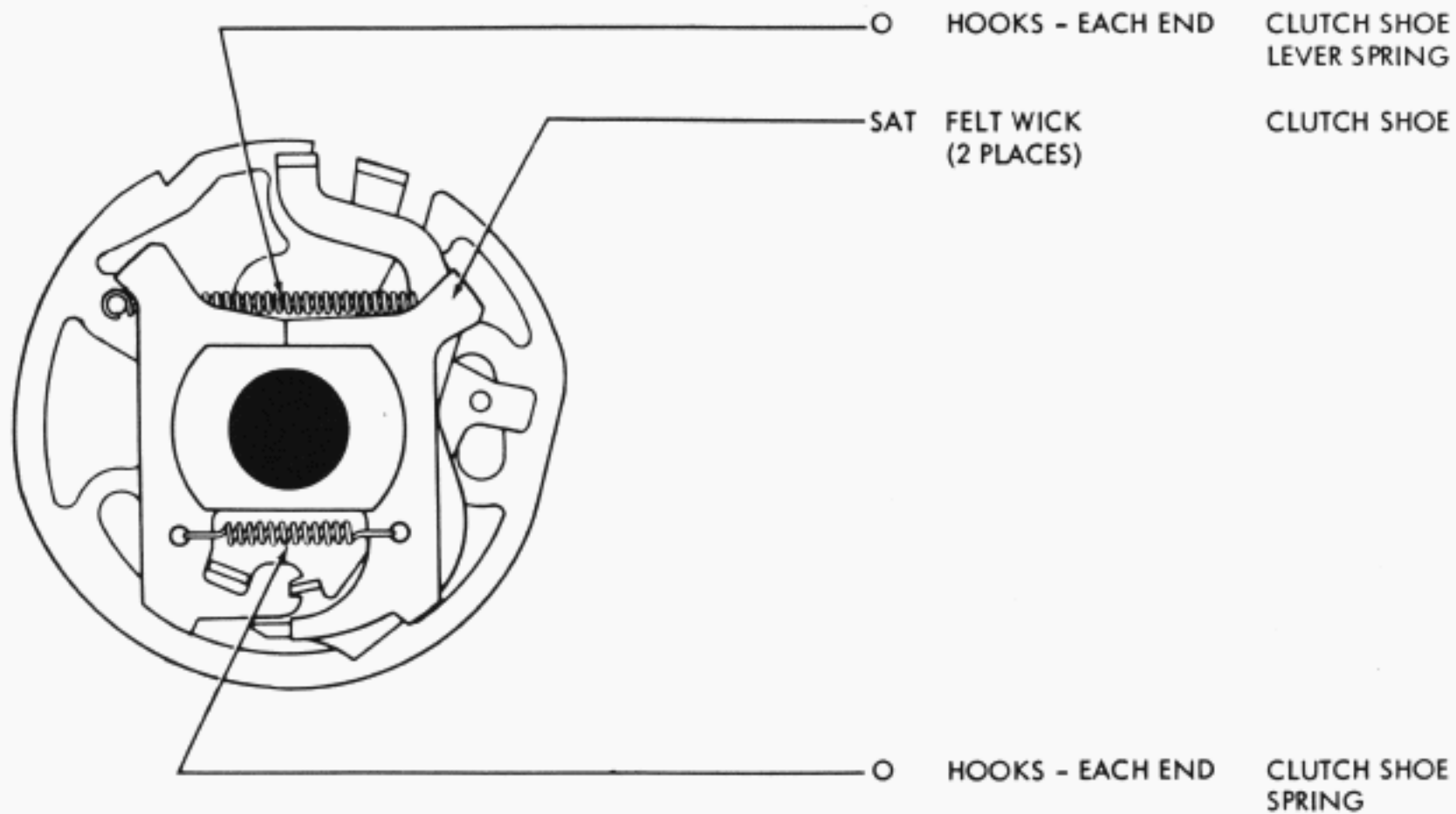

a.06 OIL RESERVOIR

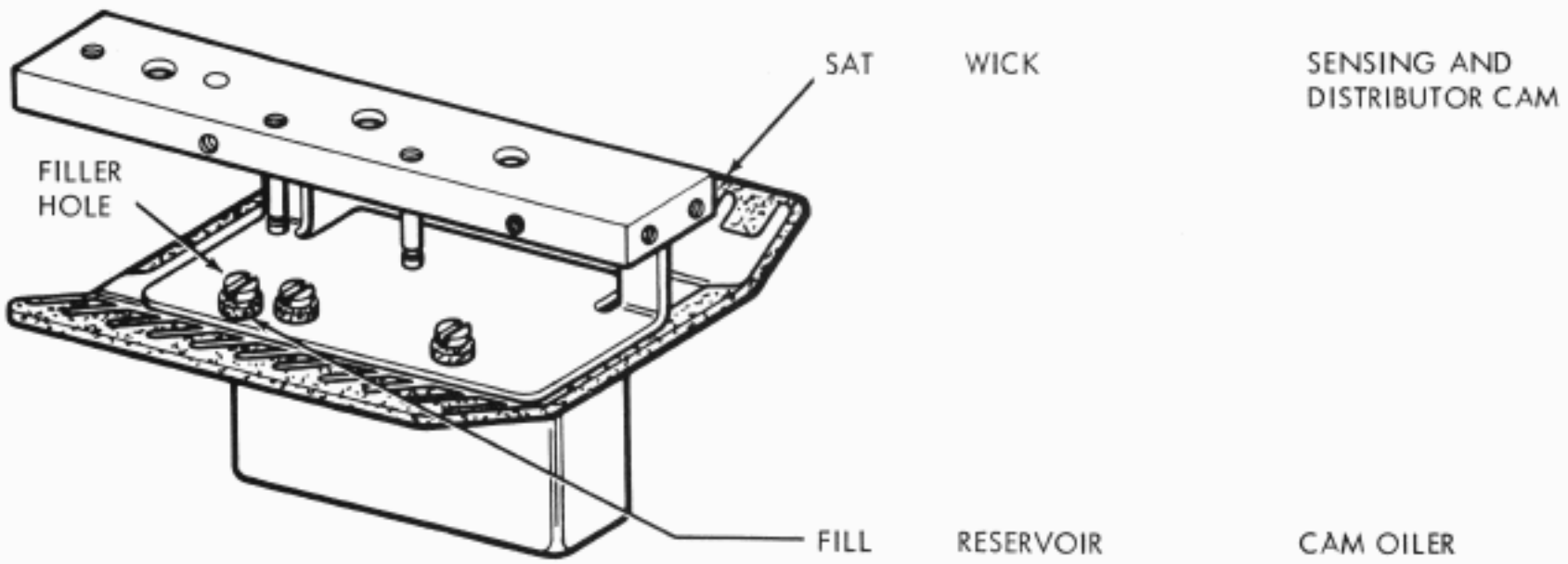

NOTE
 OIL DEPTH NOT TO EXCEED 7/8 INCH. USE A 0.010 INCH FLAT GAUGE FROM 117781 SET OF GAUGES AS A DIP STICK.

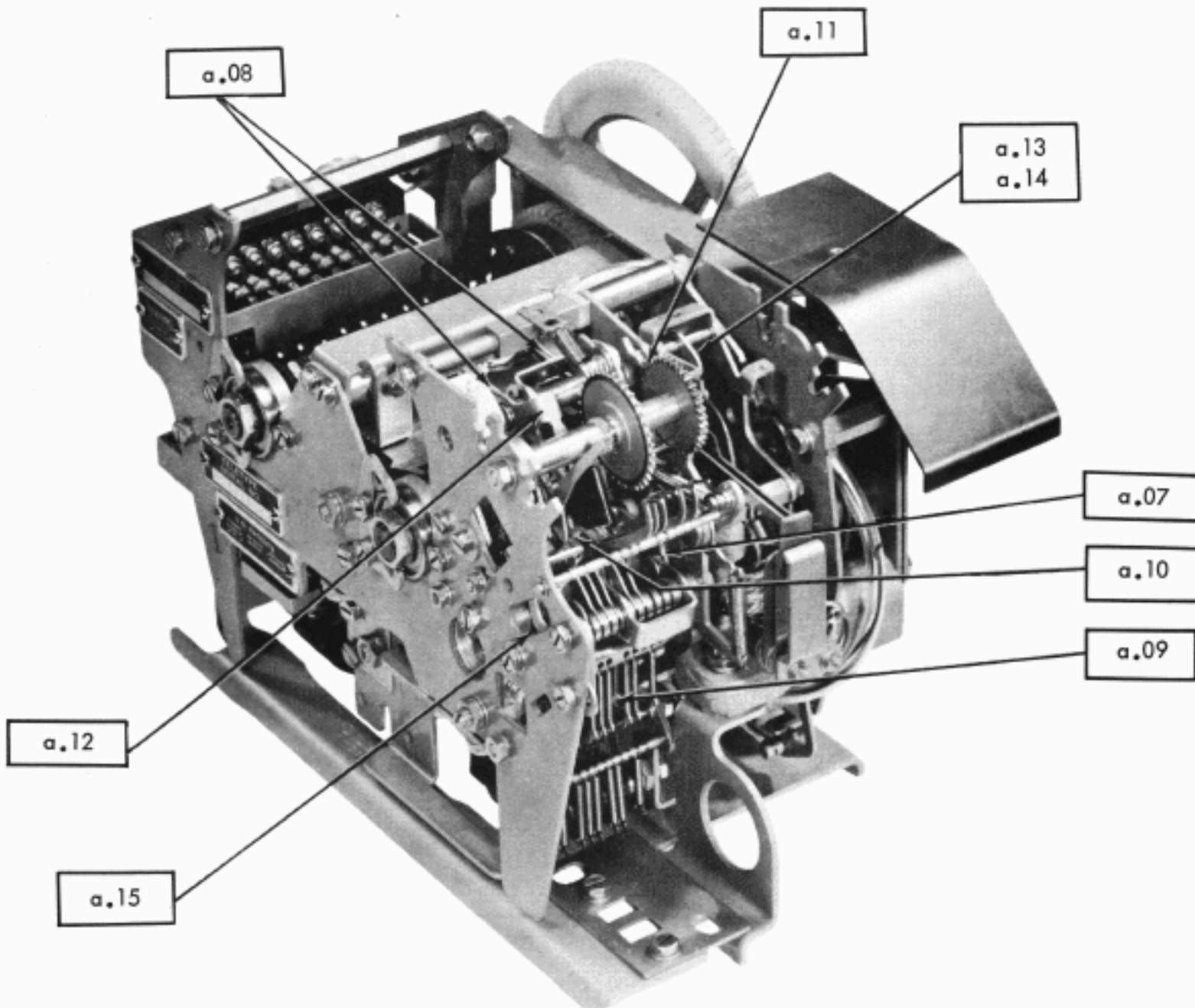

a.07 TAPE SENSING MECHANISM

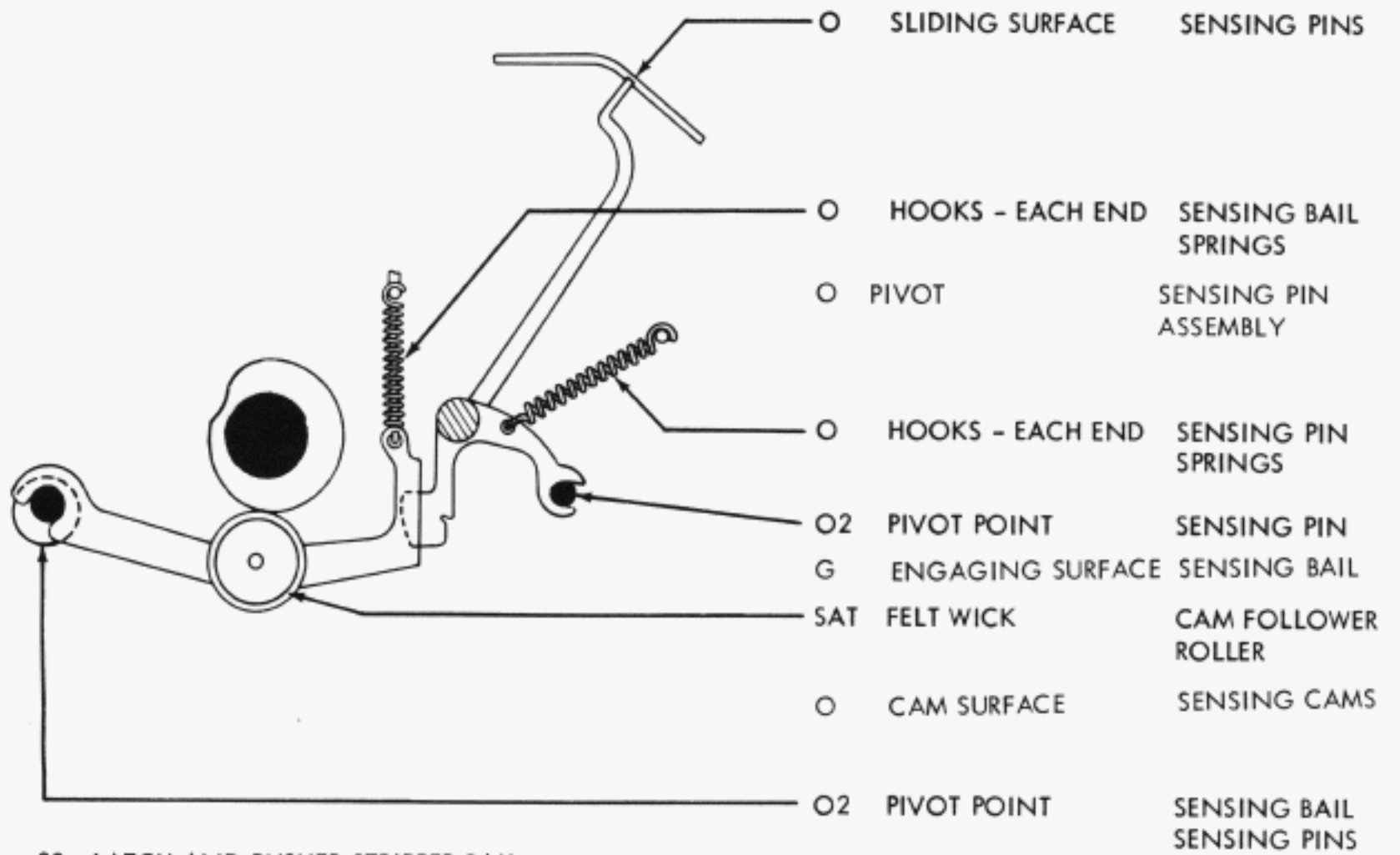

a.08 LATCH AND PUSHER STRIPPER BAIL

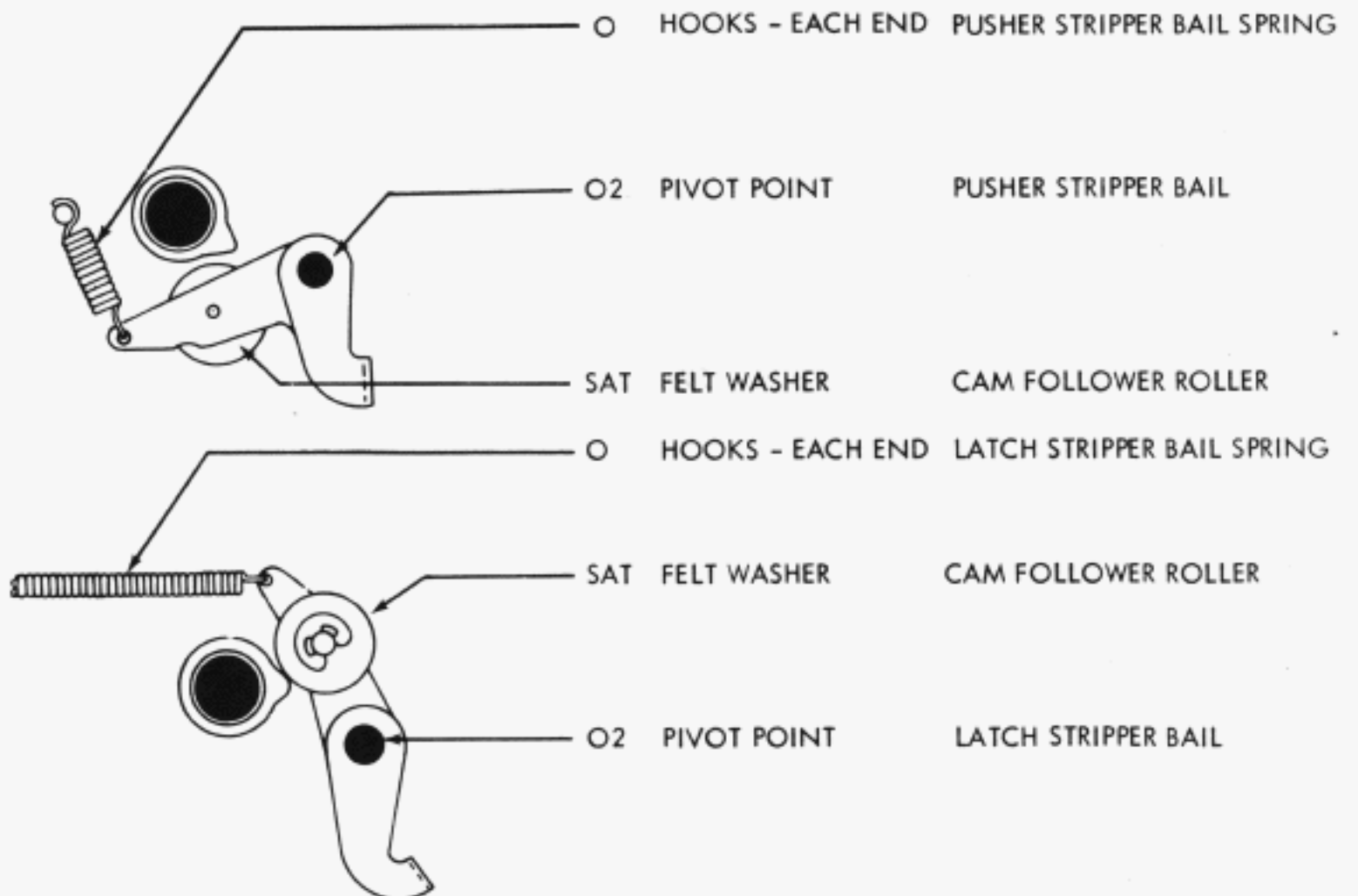

α.09 PUSHER LEVERS

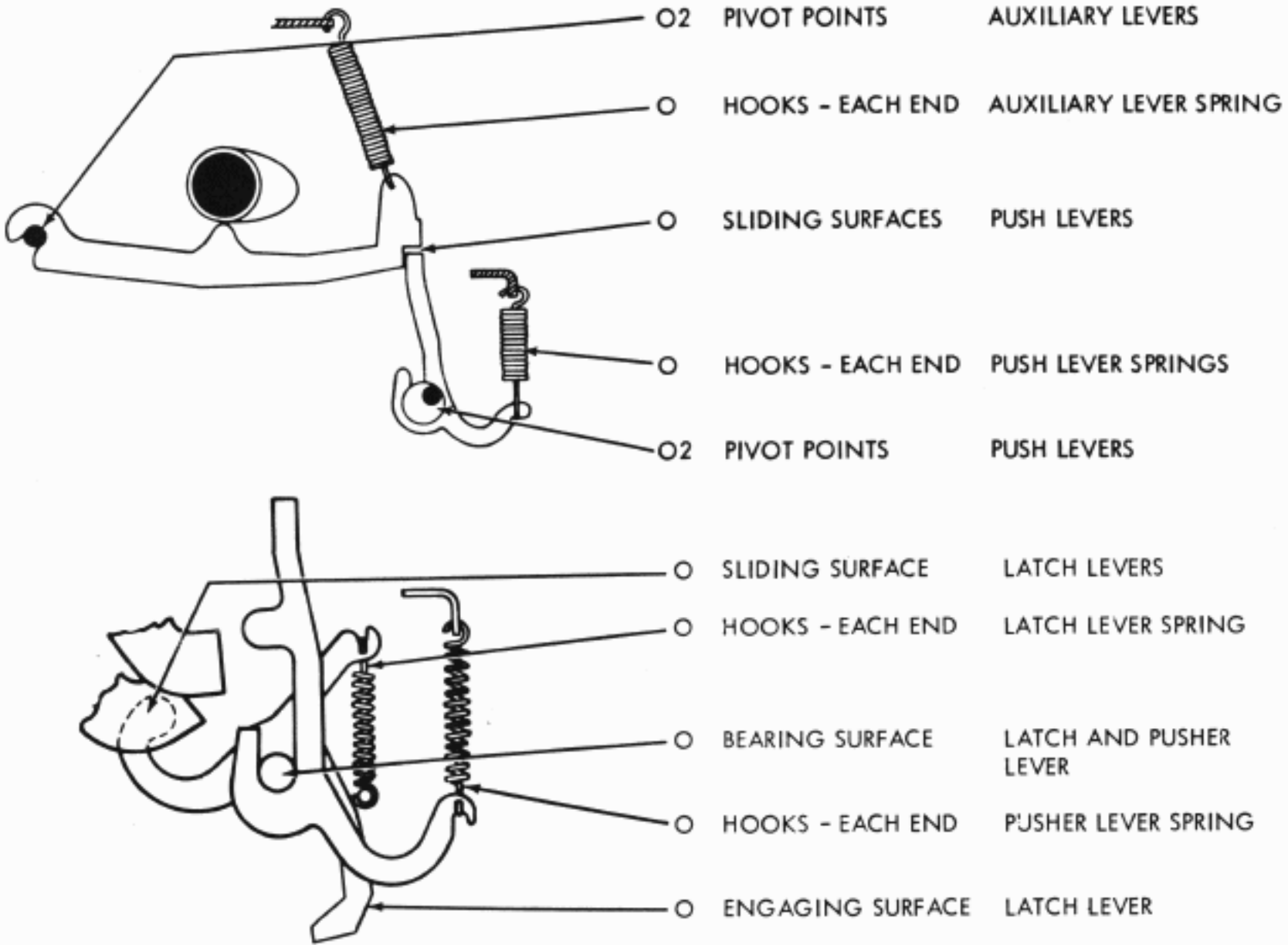

α.10 FEED MECHANISM

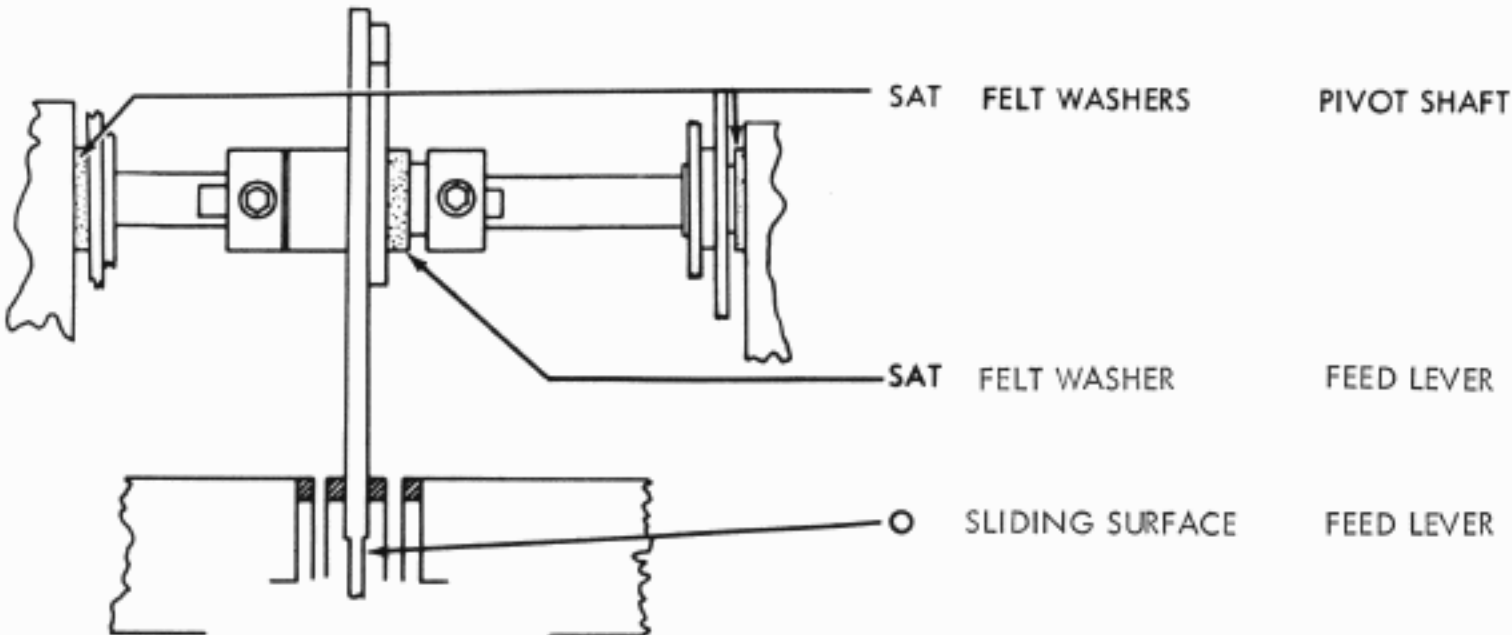

a.11 FEED MECHANISM

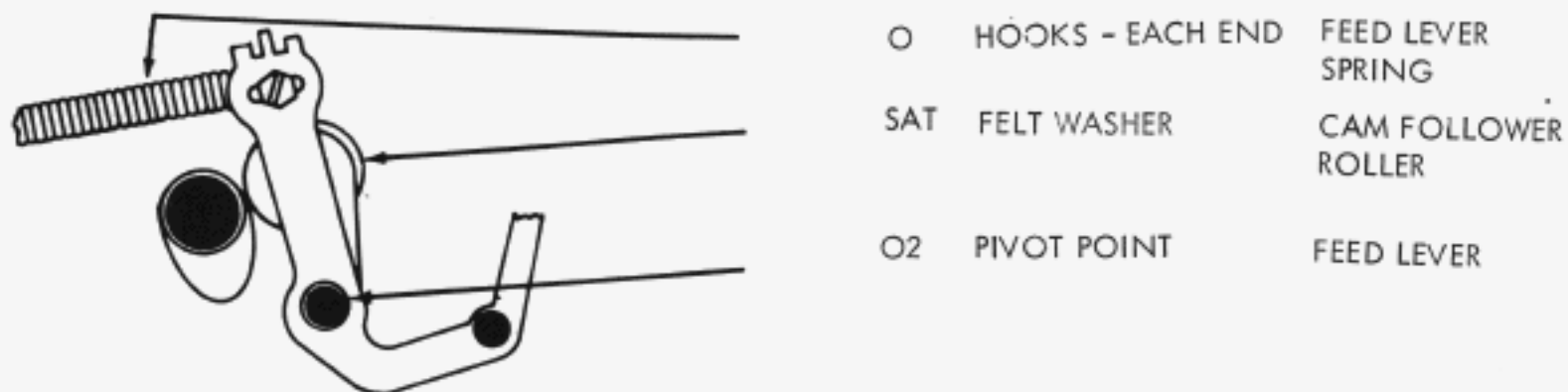
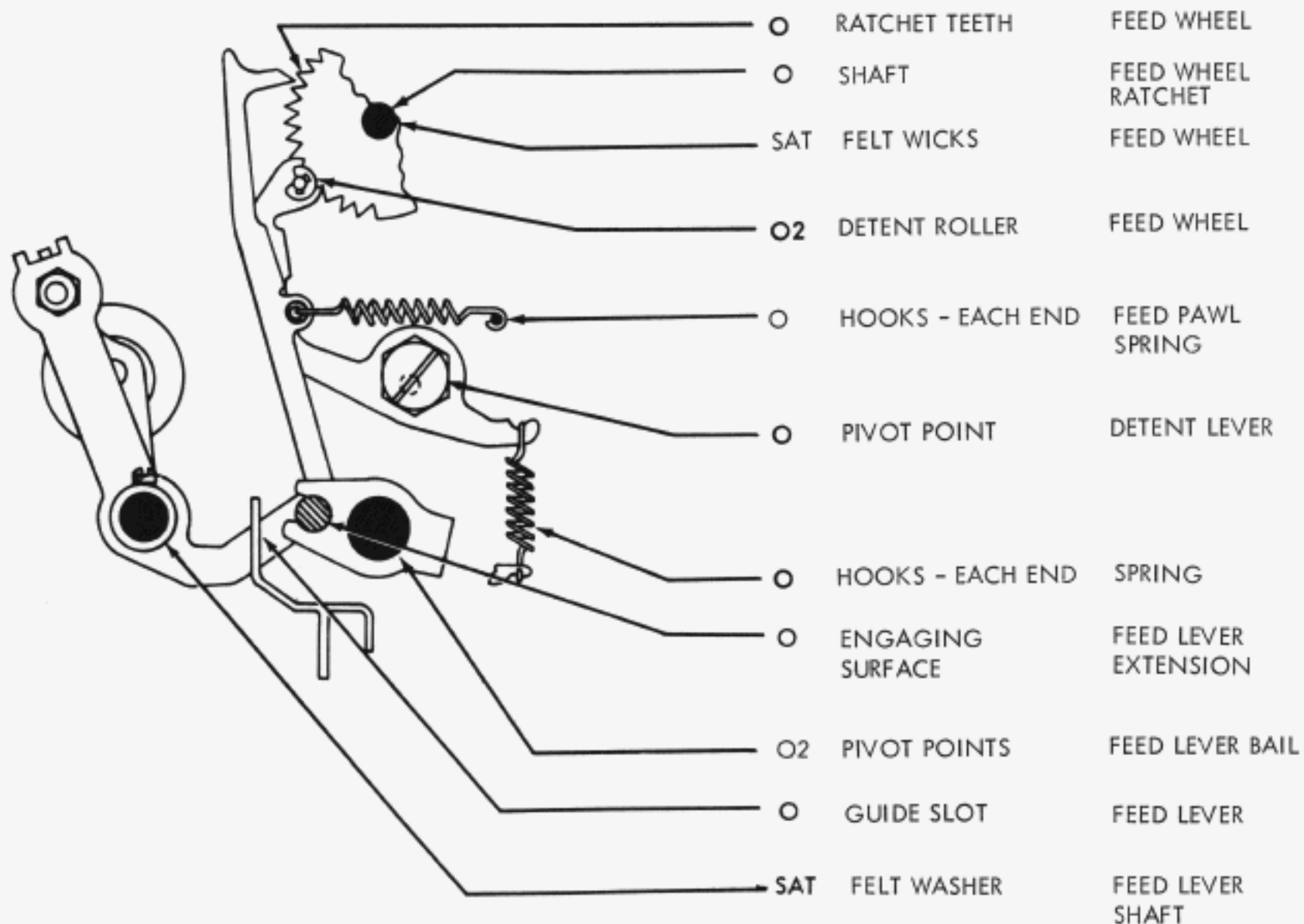

a.12 TAPE-OUT AND CONTROL MECHANISM

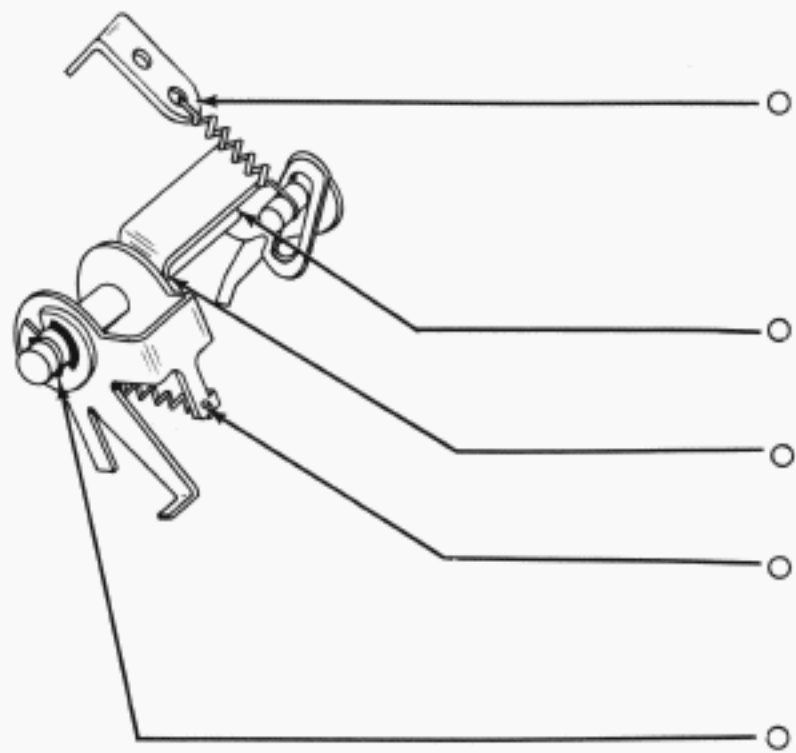

- HOOKS EACH END YIELD SPRING
- PIVOTS TAPE-OUT BAIL
- PIVOT CONTROL BAIL
- HOOKS EACH END YIELD SPRING
- PIVOT CONTROL BAIL

a.13 TIGHT TAPE SLIDE ARM ASSEMBLY

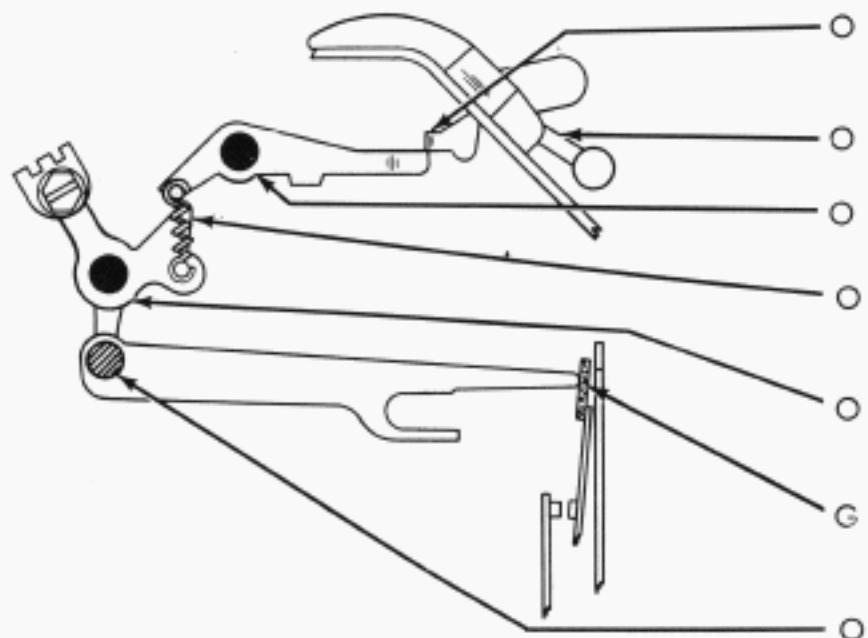

- SLIDING SURFACE TIGHT TAPE BAIL
- PIVOT POINT TIGHT TAPE BAIL
- PIVOT INTERMEDIATE BAIL
- HOOKS EACH END YIELD SPRING
- PIVOT SLIDE ARM ASSEMBLY
- POINT OF CONTACT SLIDE ARM ASSEMBLY
- PIVOT SLIDE ARM ASSEMBLY

a.14 START-STOP SLIDE ARM ASSEMBLY

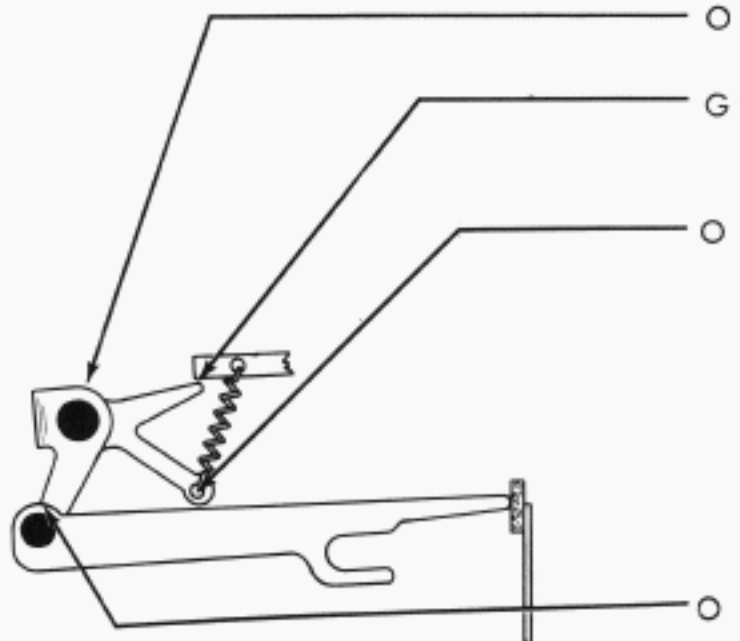

- PIVOT YIELD BAIL
- SLIDING SURFACE YIELD BAIL
- HOOKS EACH END YIELD SPRING
- PIVOT SLIDE ARM

a.15 TAPE-OUT AND TAPE LID MECHANISM

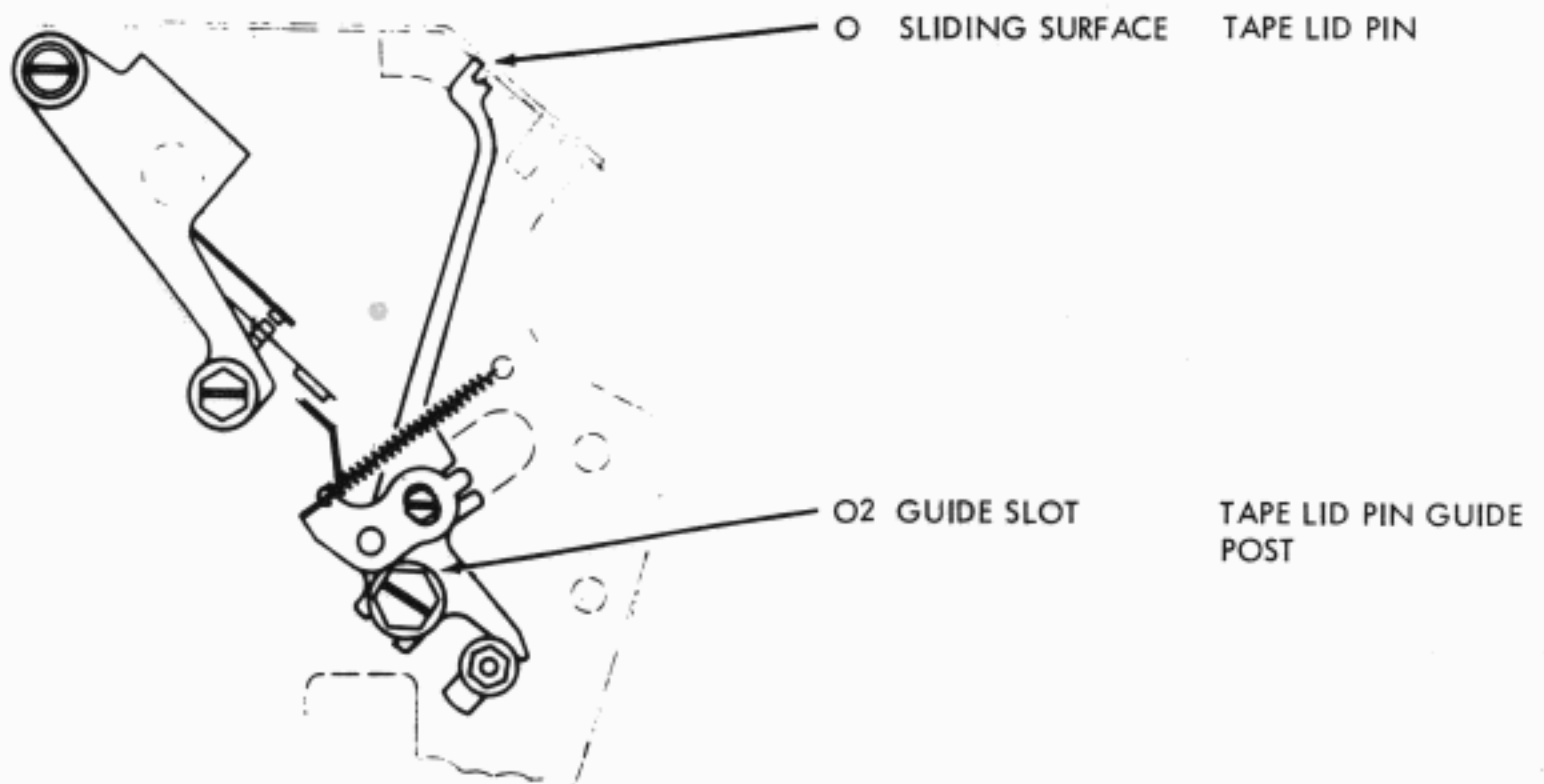
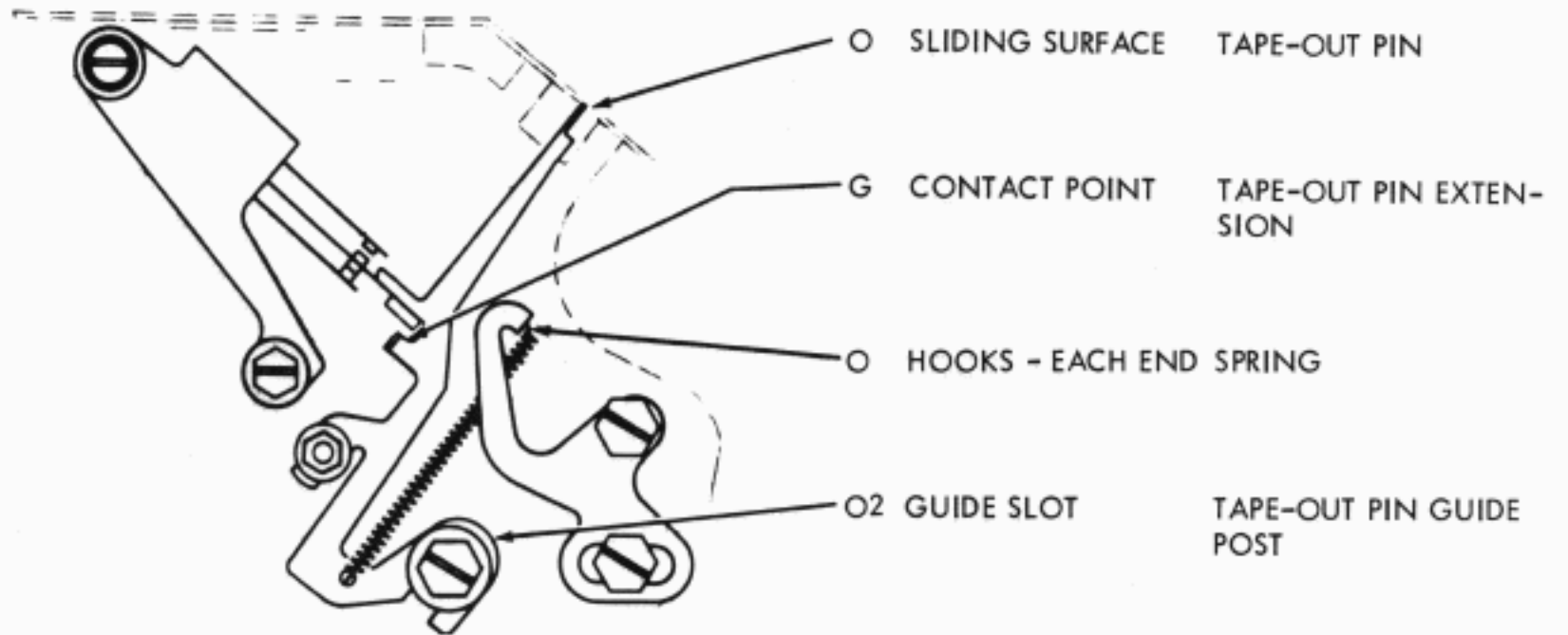

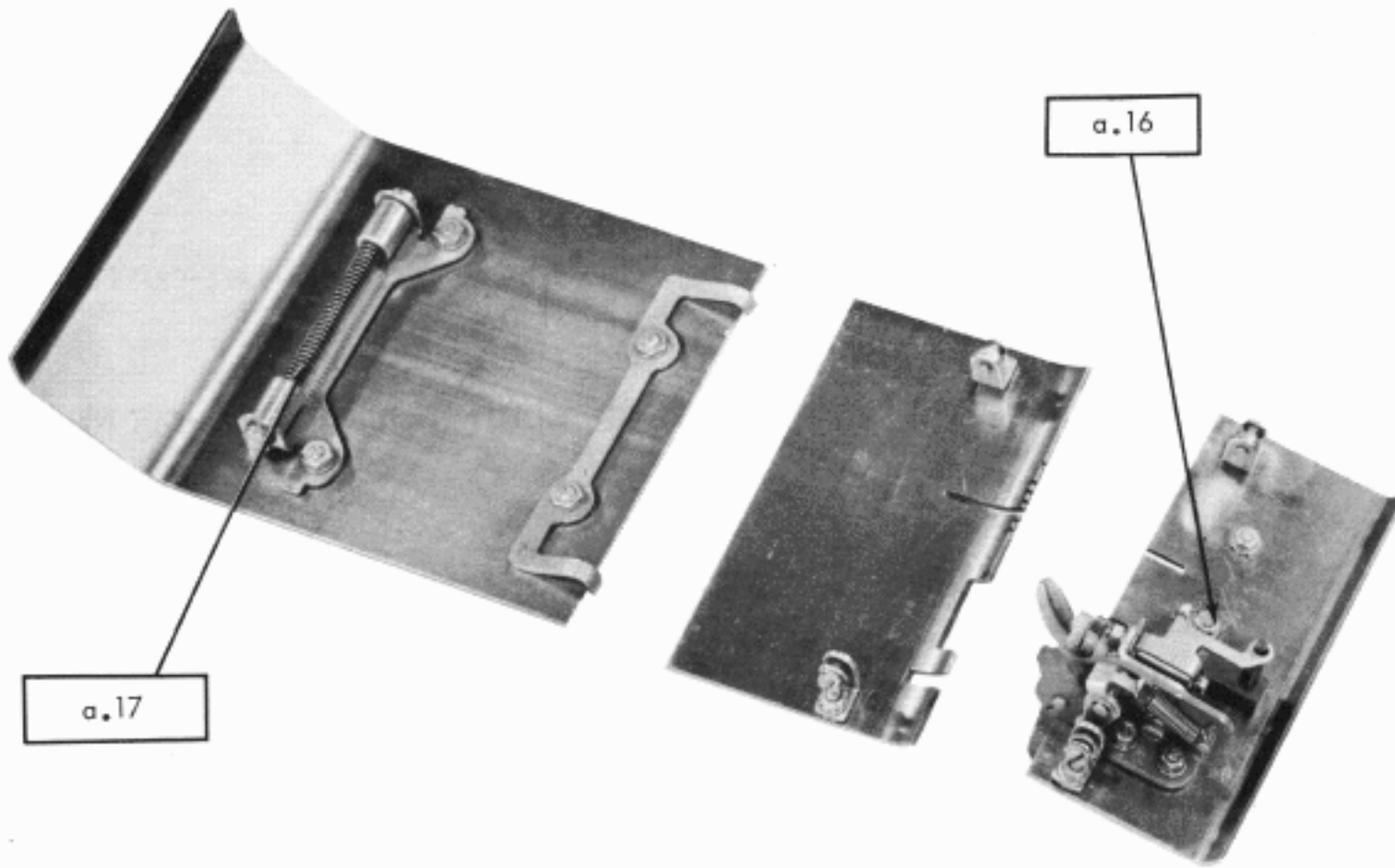

a.16 TAPE LID AND TAPE GUIDE

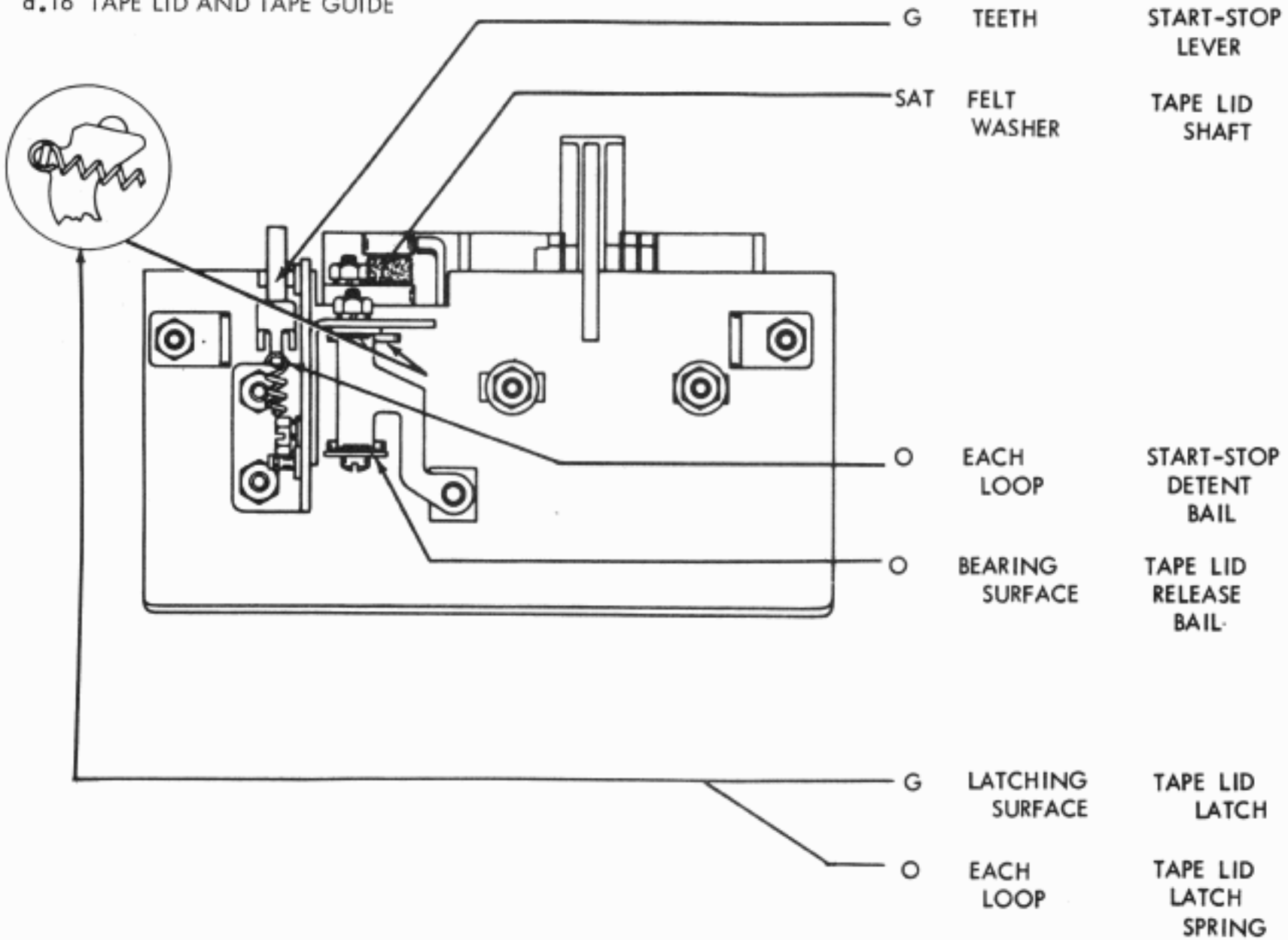

a.16 (EARLY DESIGN)

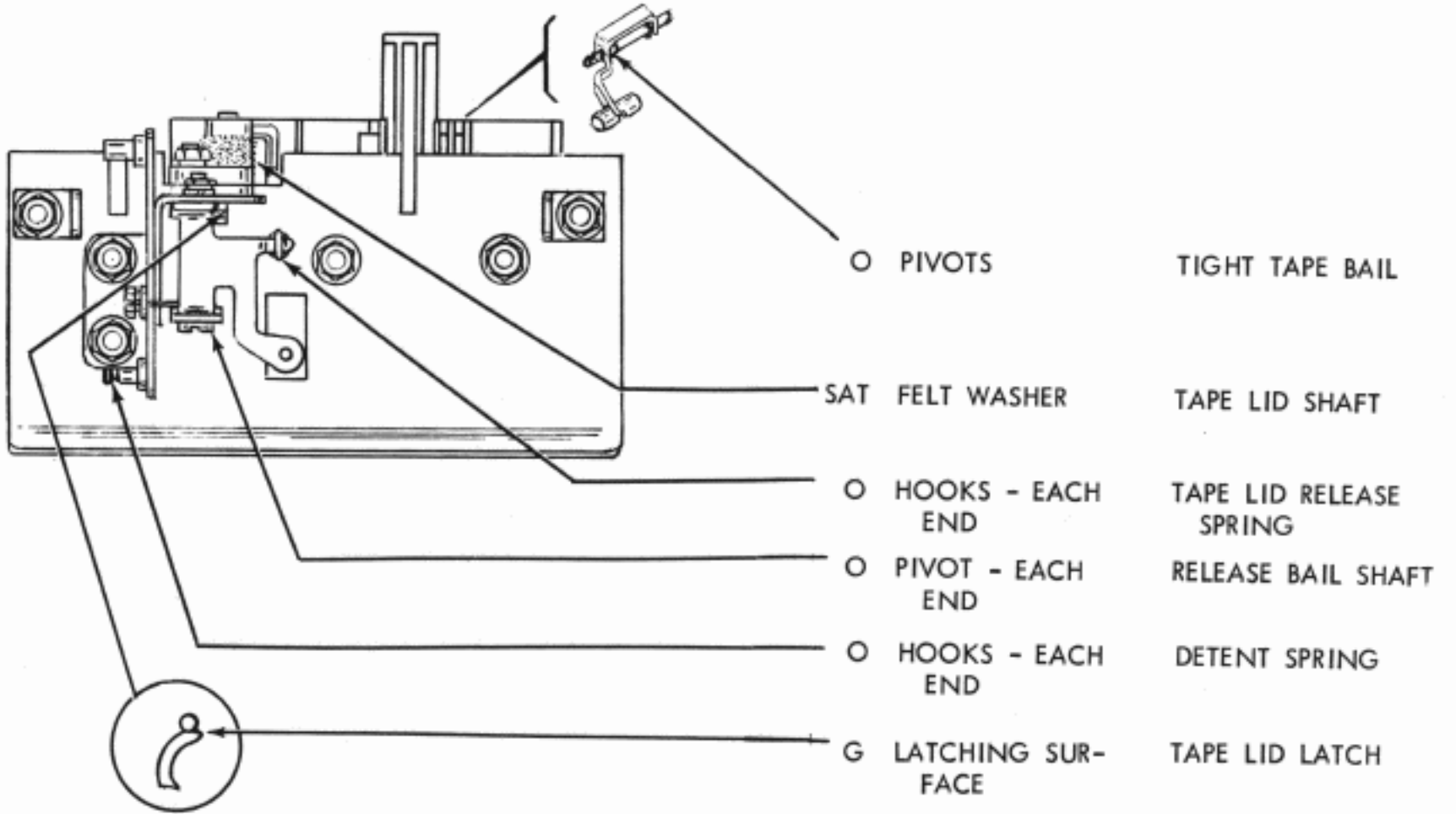

a.17 COVER PLATE

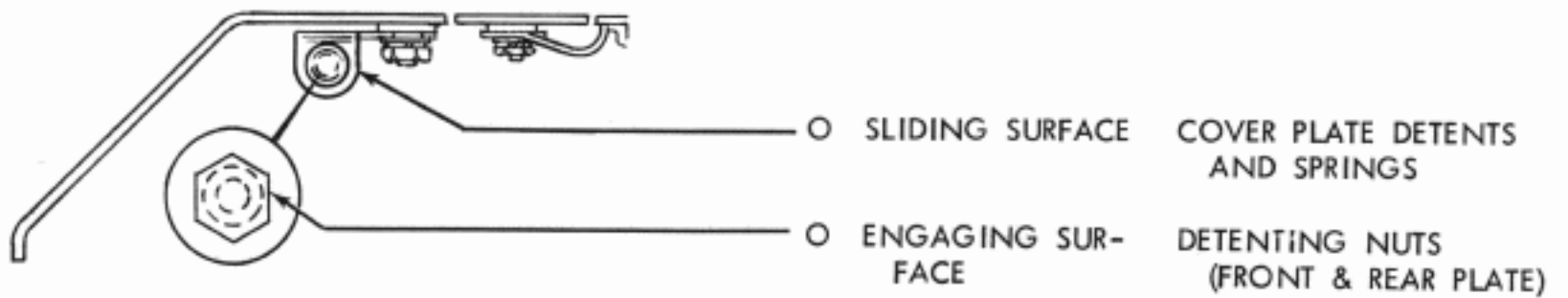

a.18 DEFLECTOR BRACKET

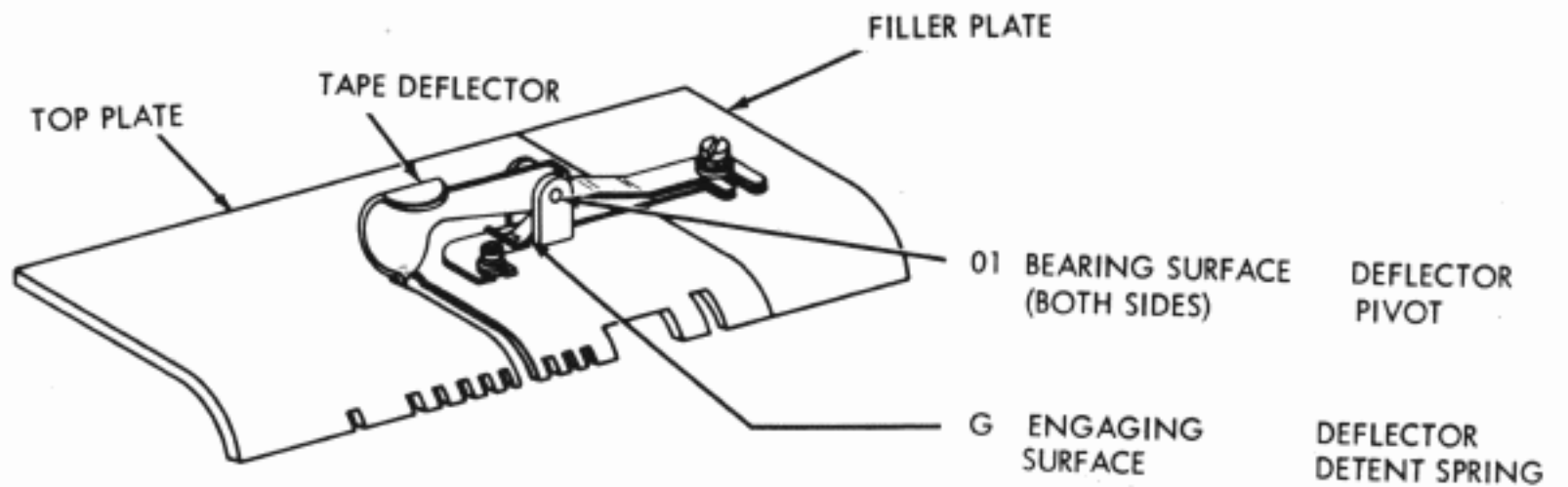

b. BASES

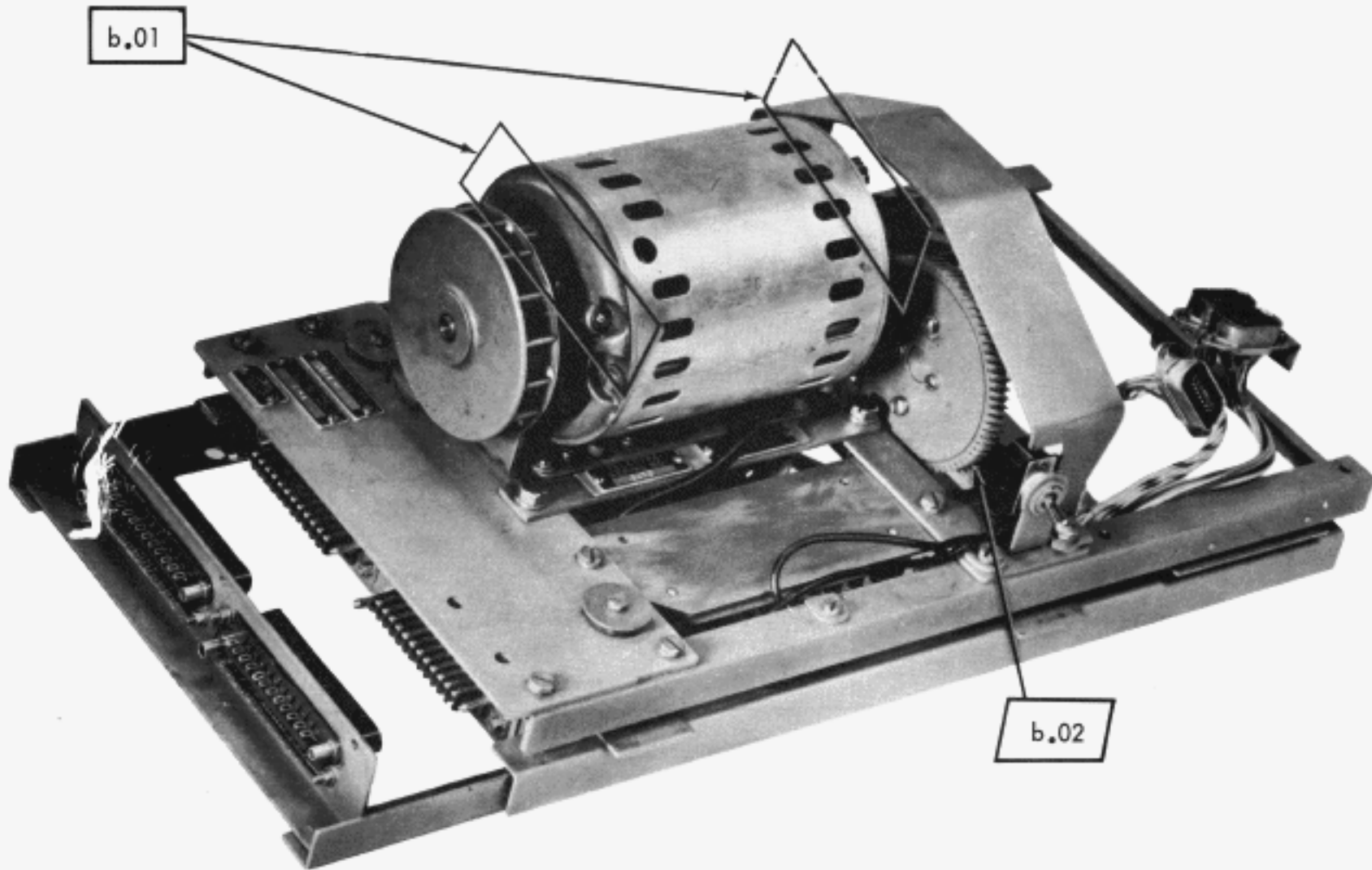

b.01 MOTOR UNIT

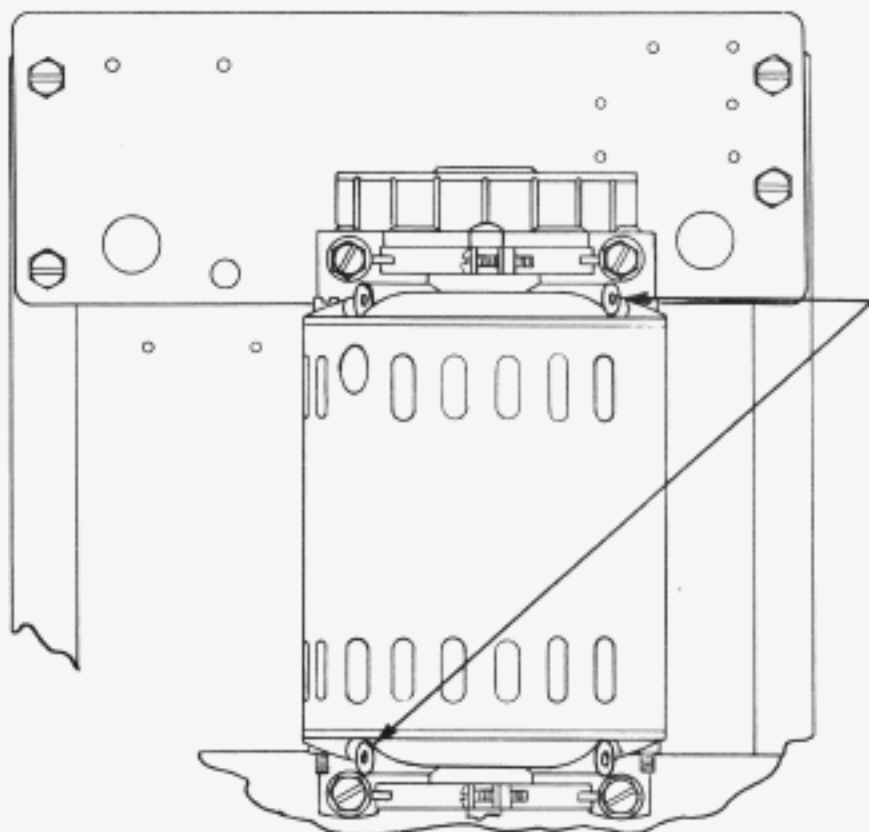

O6 BALL OILER (BOTH ENDS) MOTOR BEARINGS

LUBRICATE MOTOR BEARING EVERY FOUR MONTHS.

*IF MOTOR IS DISASSEMBLED, REPACK BEARINGS WITH BEACON 325 GREASE (TELETYPE PART NO. 195298) OR ITS EQUIVALENT.

b.02 INTERMEDIATE GEAR ASSEMBLY

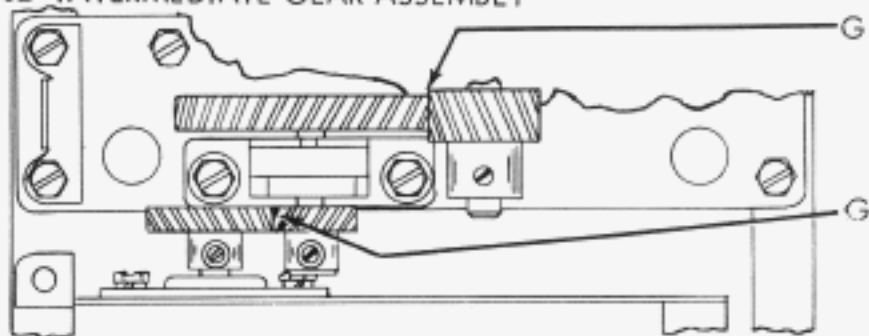

TEETH INTERMEDIATE GEAR

TEETH DISTRIBUTOR SHAFT DRIVING GEAR

b.03 LCXB - BASE FOR TRANSMITTER DISTRIBUTOR
USED IN AUTOMATIC SEND-RECEIVE CABINET

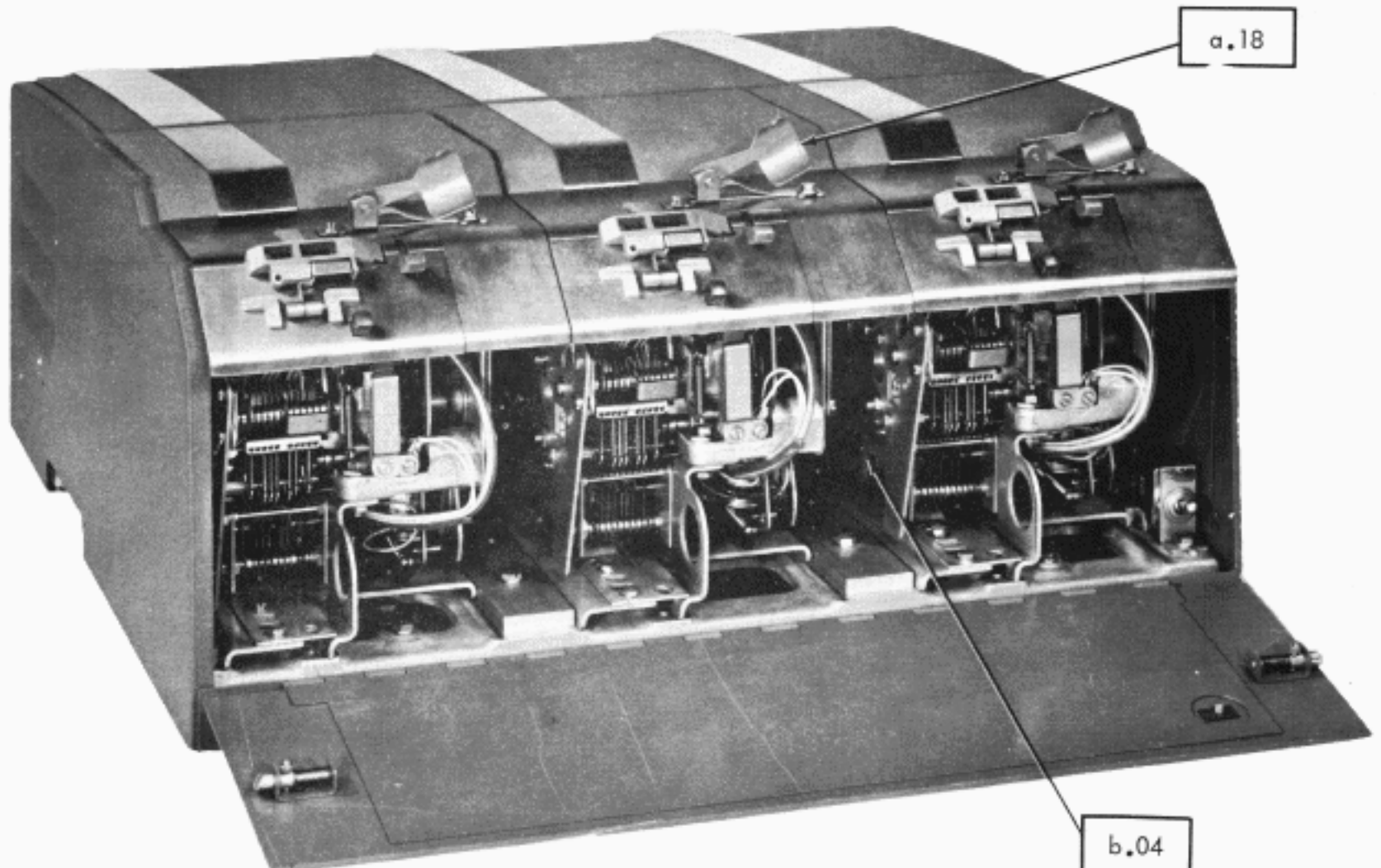
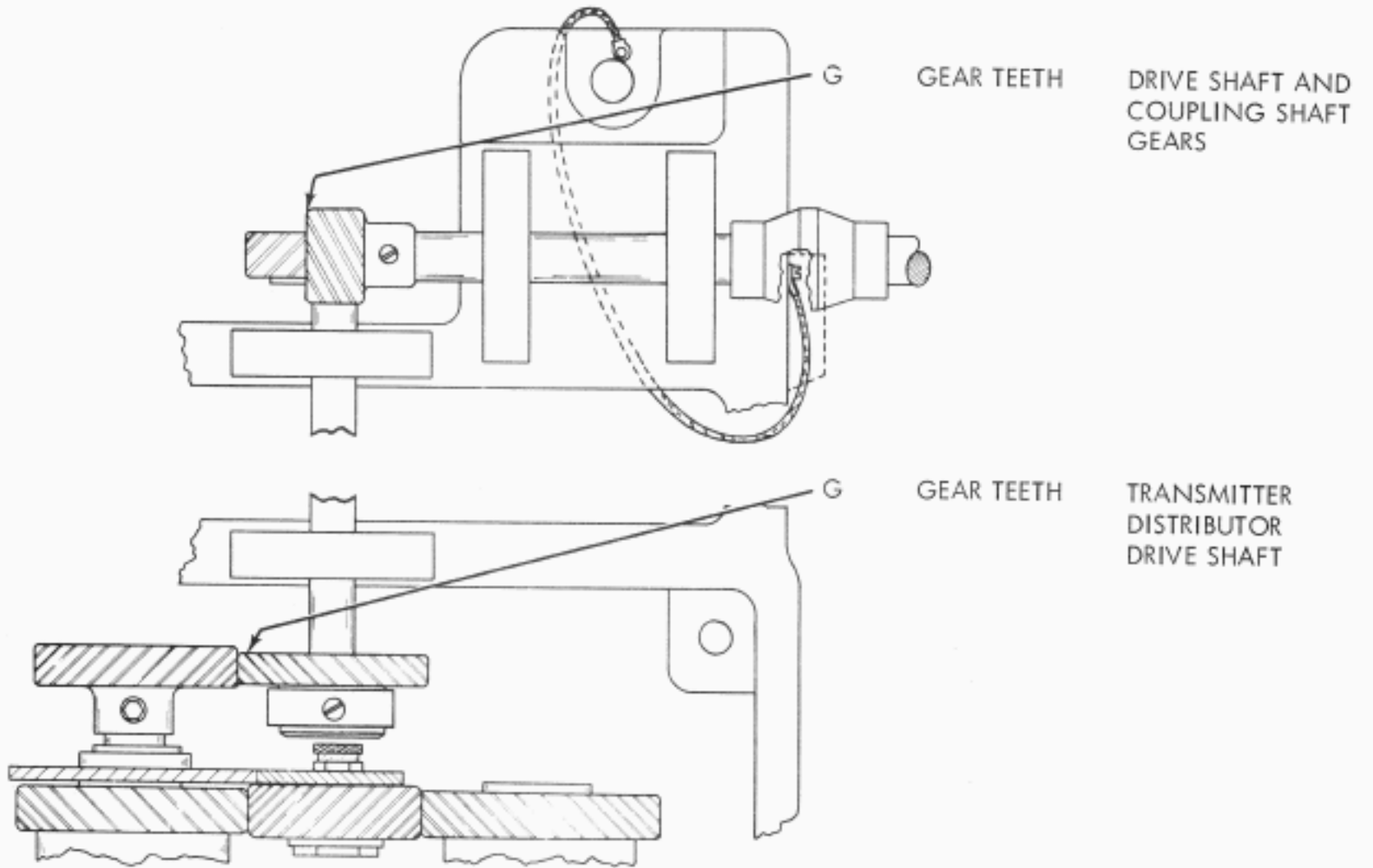

b.04 DRIVE GEAR ASSEMBLY

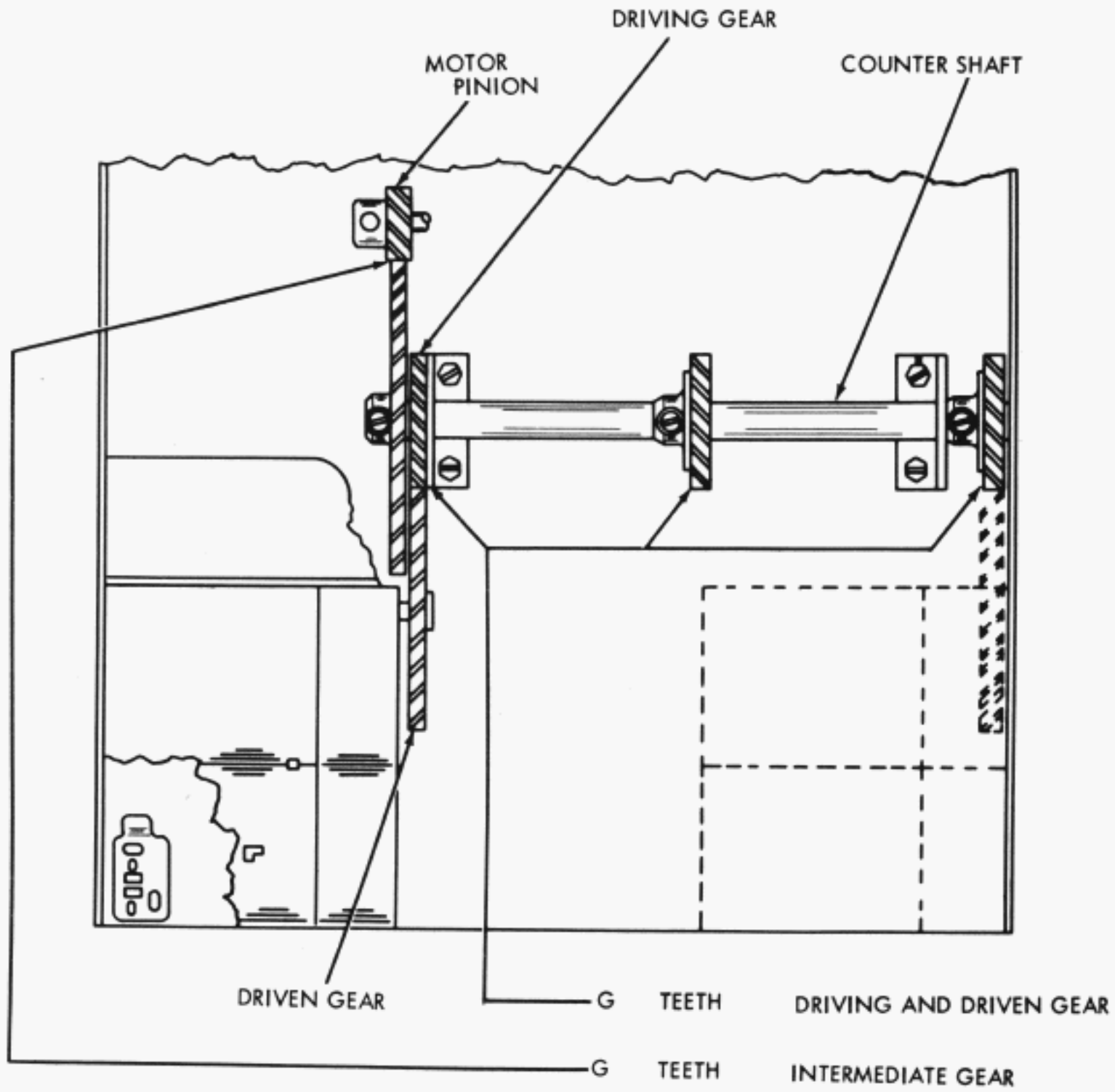

c. CABINETS

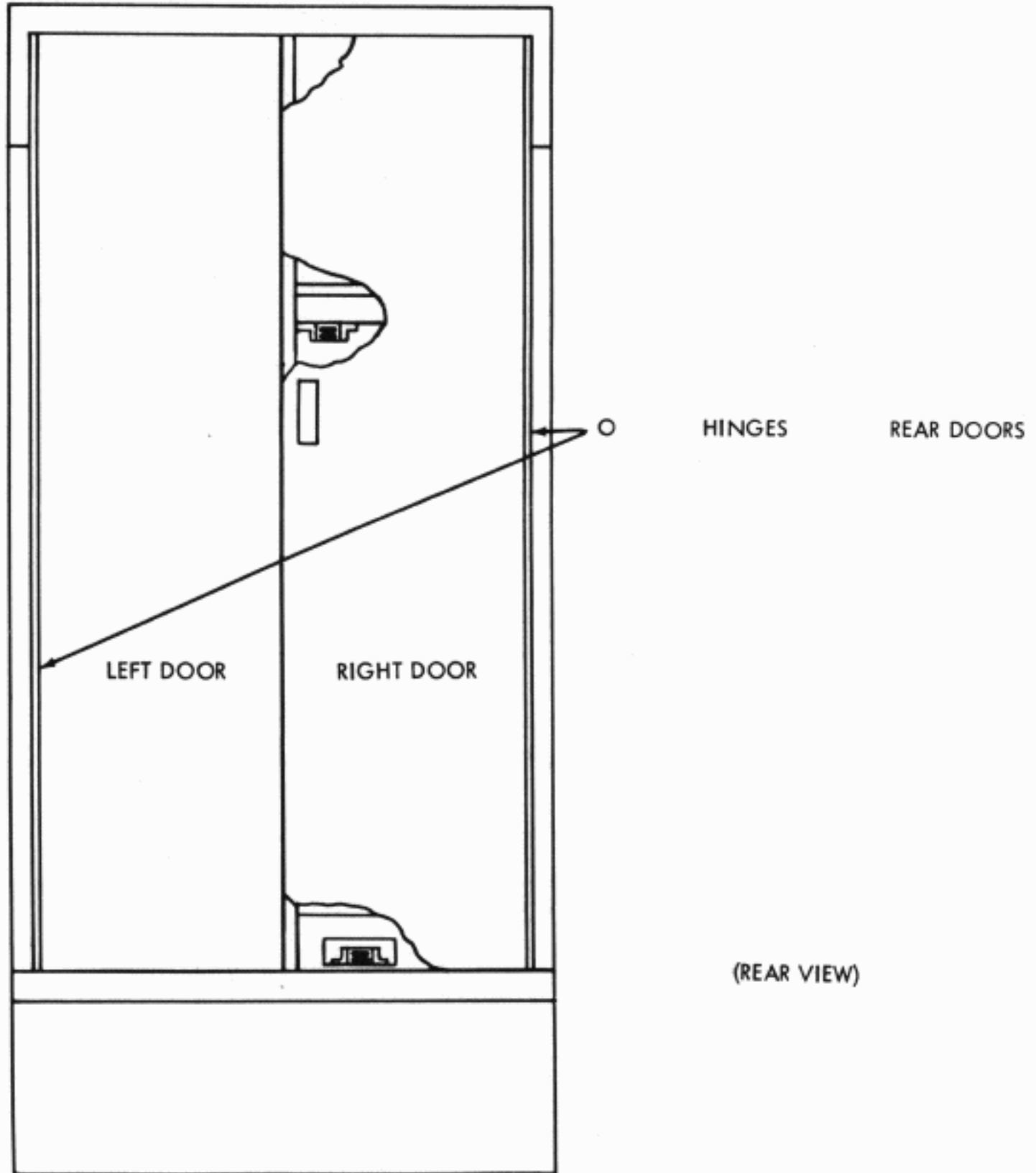

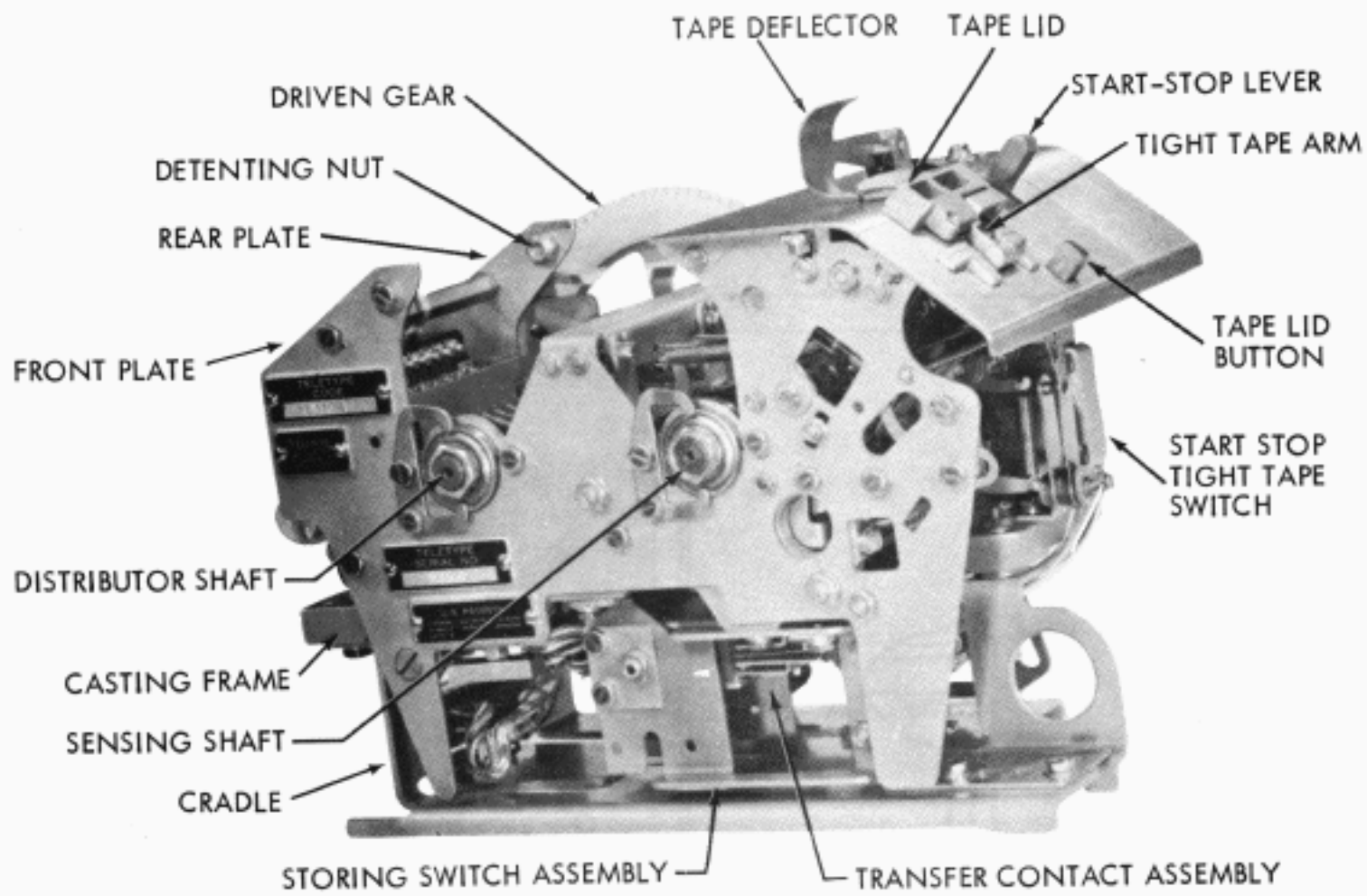

FIGURE 4-1. TRANSMITTER DISTRIBUTOR (LBXD) - FRONT VIEW

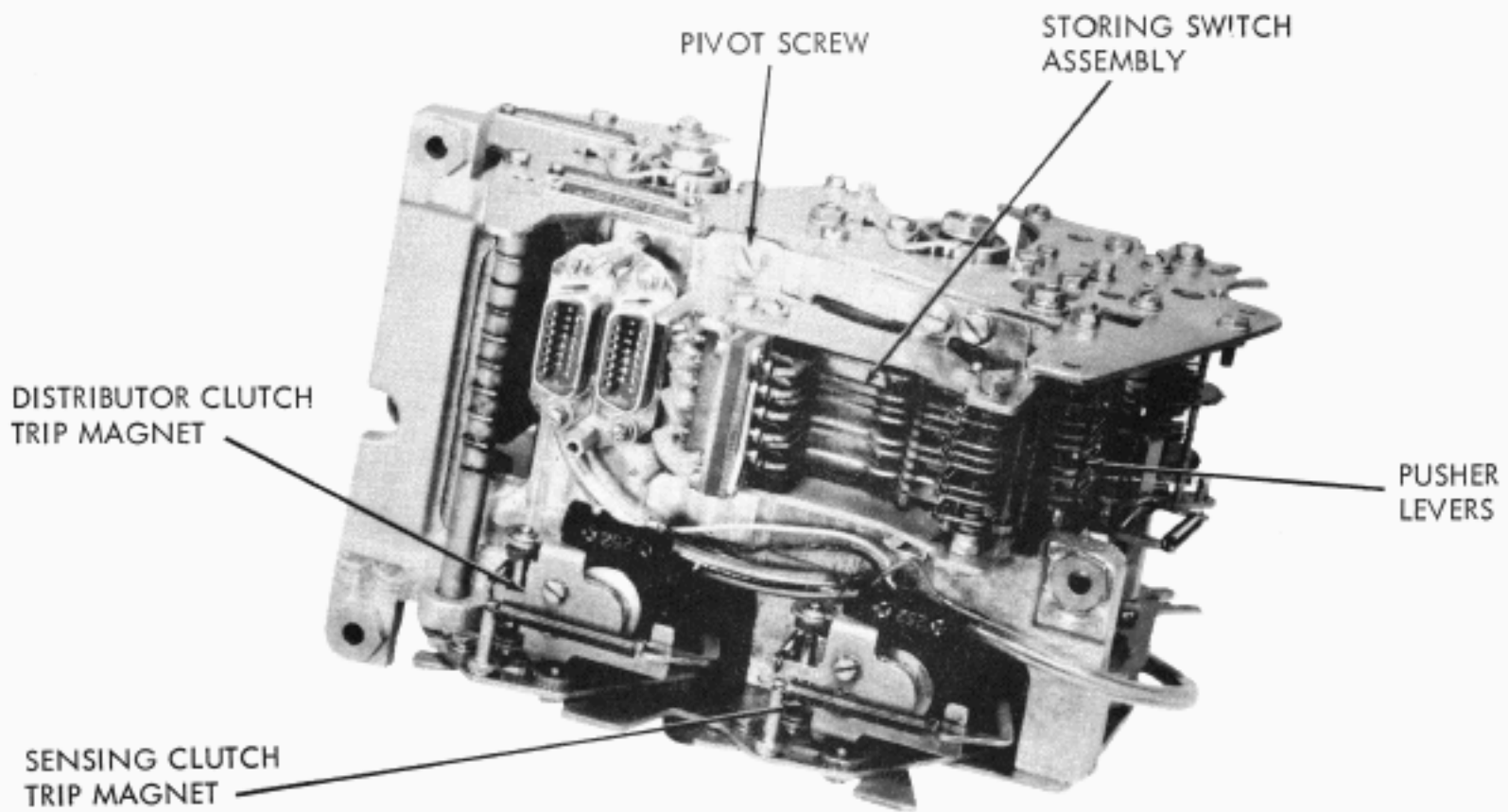

FIGURE 4-2. TRANSMITTER DISTRIBUTOR (LBXD) - BOTTOM VIEW

SECTION 4

DISASSEMBLY & REASSEMBLY

1. GENERAL

a. This section presents disassembly and reassembly instructions necessary to break the transmitter distributor (LBXD) into its various subassemblies. The instructions are arranged in a sequence which should be followed only when a complete disassembly of the unit is required. Disassembly of a specific subassembly (for replacement or repair purposes) would normally require removal of associated subassemblies in the same area. Refer to Teletype Parts Bulletin 1165B for detailed illustrations of the parts referred to in the text.

b. Perform any necessary adjustments after reassembly of the unit.

NOTE

Retaining rings (tru-arc) are spring steel and have a tendency to release suddenly. To minimize loss of these rings, remove them according to the following procedure. Hold the ring to prevent it from rotating. Place a screwdriver blade in one of the slots of the ring. Rotate the screwdriver in a direction to increase the diameter of the ring. The retaining rings will come off easily without flying.

c. Unless otherwise specified, reassembly - or replacement - of an assembly is accomplished by reversing the disassembly procedure. When necessary, specific reassembly instructions are provided.

2. DISASSEMBLY AND REASSEMBLY OF (LBXD) TRANSMITTER DISTRIBUTOR (Refer to Figures 4-1 and 4-2)

a. Motor Cover and Front Panel Removal

(1) To remove the motor cover, lift it carefully upward to clear the mechanism.

(2) To remove the front panel, pull outward on the lower right and left rear corners of the front panel, and slide the panel forward. To replace, mate the front panel slides with the frame slides. Push slowly toward the rear, applying even pressure at each edge of the front plate.

b. Removal of Transmitter Distributor from Base - To remove the transmitter distributor from the base, remove the three mounting screws which secure the unit to the base. Slide the unit forward and lift upward to disconnect the latches and electrical connectors.

c. Cover Plate - Remove the cover plate by lifting the left end upward, and sliding the plate toward the left to disengage the spring clip.

d. Top Plate

(1) Remove the top plate by loosening the front and rear mounting screws. Lift the plate upward.

(2) To replace, guide the mounting screws into their respective notches on the front and rear plates. Align the sensing pins and feed wheel with their respective slots.

e. Tape Guide Plate

(1) The tape guide plate is removed by loosening the front and rear mounting screws and sliding the plate upward.

(2) To replace, guide the mounting screws into their respective notches on the front and rear plate. Guide the tape-out pin into its hole, and locate the sensing pins against the left edge of the tape guide plate.

f. Oil Reservoir Assembly - To remove the oil reservoir assembly, unhook the springs attached to the underside of the cross bar. Remove the four screws which secure the cross bar to the front and rear plates and lift the assembly upward.

g. Distributor Block Assembly - To remove the distributor block assembly remove the nuts that secure the cable connector to the rear plate (if unit is so equipped). Remove the three screws which secure the assembly and lift it out. On those units where the electrical connector is mounted on the bottom of the unit casting, lift the assembly out only far enough for servicing.

h. Idler Gear Assembly - To remove the idler gear, remove the lock nut securing the shaft to the rear plate. This assembly should be removed before removal of the sensing and distributor shaft assemblies.

i. Distributor Shaft Assembly - To remove the distributor shaft, remove the three mounting screws which secure each bearing clamp to the front and rear plates.

j. Sensing Shaft Assembly - To remove the sensing shaft, remove the three mounting screws which secure each bearing clamp to the front and rear plates.

k. Feed Wheel Assembly

(1) To remove the feed wheel assembly, remove the nut which secures the feed wheel mounting post to the front plate. Remove the post, with wheel, from the unit.

(2) When replacing the assembly, make sure the shoulder of the mounting post will not interfere with the top plate or guide plate front mounting brackets when these plates are installed.

l. Storing Switch Assembly

(1) Non-Transfer Type Contacts

(a) Remove the two screws which secure the cable connector to the bracket beneath the casting. Remove the four mounting screws which secure the assembly to the casting. Remove the switch assembly, taking care not to damage the contact lever slides.

(b) Reverse the above procedure to reinstall the storing switch assembly. Replace the left front screw first, and use it as a pivot point when aligning the slides with their respective pusher and latch levers.

(2) Transfer Type Contacts

(a) To remove the storing switch assembly, remove the four screws which secure the assembly to the main casting. Withdraw the switch far enough to permit servicing, without disconnecting any electrical connections (if possible). When removing the switch, take care not to damage the contact lever slides.

(b) Replace the storing switch assembly according to paragraph 2.1. (1)(b) above.

m. Pusher and Latch Levers

(1) Remove the pusher lever springs. Remove the pusher levers by sliding them downward.

(2) To remove the latch levers, remove the latch lever springs. Remove the 158846 spring post attached to the front plate. Remove the latch levers by rotating them counter-clockwise and lifting upward.

n. Sensing Pins

(1) Position the 158522 sensing bail eccentric shaft to move the sensing bail to the left (toward sensing cam sleeve).

(2) Rotate the sensing shaft until the

sensing bail is in its uppermost position.

(3) Remove all the sensing pin springs. Rotate the bell cranks downward and remove each sensing pin assembly.

(4) When replacing the sensing pins, make sure the sensing bail is in position as outlined in (1) and (2) above.

o. Switch Actuating Mechanism (Start-Stop, and/or Tight Tape).

(1) To remove the switch slide arm assembly, remove the two screws, one nut, and spacer which secure the intermediate plate to the center plate. Remove the nut which secures the bail mounting post to the center plate. Remove the intermediate plate, and remove the bail and slide arm assembly. To replace, reverse disassembly procedure.

(2) To remove the tape-out switch, remove the mounting screws that secure the switch to the front plate. Loosen the screw securing the 158535 post to the center plate. Remove the screw far enough to allow post removal. Replace in reverse order.

p. Center Plate Assembly - To remove the center plate assembly, remove the two screws which secure the 158535 post in position. Remove the post and studs. Remove the screw, lock washer, and flat washer from the rear of the 158531 shaft. Pull away by lifting up on the center plate (the center plate is hooked over the pivot shaft), and working it out to the right.

q. Sensing Assembly - To remove the sensing mechanism, remove the pivot shaft by loosening the nut, set collars and the two retaining rings. Slide the shaft out and remove latch bail, pusher bail and the feed lever assemblies. Remove the sensing bail.

r. Clutch Trip Assembly - To remove either clutch trip assembly, remove the mounting screws and nuts. On earlier units, remove the electrical connector mounting screws. Remove the clutch trip assemblies with connector, switches, and associated cabling. On later units, the wiring will be long enough to permit most servicing without completely removing the assembly. If necessary, unsolder the leads at the magnet coils.

s. Frame Assembly - Remove all screws and/or nuts that secure eccentric shaft to side frame and/or casting. Remove all screws mounting front and rear plates to casting and disassemble completely.

3. DISASSEMBLY AND REASSEMBLY OF BASE (LCXB) THAT SUPPORTS THE TRANSMITTER DISTRIBUTOR ON THE AUTOMATIC SEND-RECEIVE SET (Refer to Figure 4-3)

a. Housing - Pull the Front Panel forward to disengage the right and left spring latch. Remove the 82730 shoulder screw, and the 151623 screw with its 2669 lock washer and 117535 washer from the right end of the 160286 cross bar. With the screws that secure the left end of the bar loosened, remove the cross bar. Replace in the reverse order.

CAUTION

On units equipped with noise reduction feature, no portion of the transmitter distributor (covers, etc.) or its drive mechanism should come into direct contact with the cabinet. Position transmitter distributor as follows:

(1) Lower edge of top plate and tape guide plate should clear front cover by at least 1/32 inch.

(2) Clearance between edge of front cover and unit should be at least 1/32 inch.

(3) To adjust - refine cradle height, and/or front rail position.

b. Front Cover Plate - Remove the screws, lock washers, and flat washers which secure the front cover plate to the transmitter distributor.

c. Mounting Screws - Remove the three screws, lock washers, and flat washers which secure the transmitter distributor to the base. Replace in reverse order, and position the unit for minimum backlash of the driving gear.

d. Cable Connectors - To disconnect the main cable of the base from the associated equipment, remove the lock nuts that secure the plug to its receptacle (on units so equipped). Replace in reverse order, routing the cable away from any moving parts.

e. Driving Gear Assembly (Speed Change Requirements)

(1) Gear Guard - To remove the 152045 gear guard, remove its mounting screw,

(2) Motor Pinion

(a) Units without noise reduction isolating members - Loosen the set screws in the 158020 rubber coupling on the 158079 shaft and the coupling attached to the motor pinion. Replace the gear set with the new speed, set of gears.

(b) Units with noise reduction isolating members - Disassemble in the same manner as paragraph (a) above, except for the motor pinion. Remove the 161301 post (2) which secures the isolator to the motor shaft. Note that the isolator has two projections which engage the counterbored mounting holes (2) in the pinion. To reassemble, apply a thin film of grease to the motor shaft. Place the isolator over the hub of the pinion and press the projection (shoulder) down into the counterbored holes in the pinion. Slip the assembly on the motor shaft with the teeth toward the motor. Push each post through the respective hole in the isolator and secure them to the motor shaft.

(3) LCXB Drive Shafts

(a) Speed Change Set of Gears - Remove Gear Guard. Remove the screw and lock washer securing the 158012 shaft. Remove the gear mounting screws. When a new speed is required, replace the gear and pinion with the appropriate gear set and reassemble in the reverse order. If the base is to be removed, loosen the 158020 rubber coupling set screws.

(b) Transmitter-Distributor Drive Gear

1. Units without noise reduction isolating member - Remove the screw and lock washer which secure the 159836 gear to the main shaft. Replace in reverse order.

2. Units with noise reduction isolating members - Remove the two 161301 posts which secure the isolator and gear to the 159838 shaft. The isolator may be removed if further disassembly is required. Reassemble in reverse order, first applying a light film of grease to the 159838 shaft extension. Place the isolator over the hub of the nylon gear. Press the projections (shoulders) down into the counterbored holes in the gear. Slip the gear with the isolator over the greased shaft (gear teeth toward the bracket). Push the posts down through the holes in the isolator and screw them into the shaft.

f. Base Mounting Hardware

(1) Units without noise reduction isolating members - Remove the three screws, lock washers, and flat washers that secure the base casting to the cradle of the cabinet. Replace in reverse order, but leave the screws friction tight for shaft alignment.

(2) Units with noise reduction isolating members - Remove the nut, lock washer, flat washer and rubber bushing from each of the studs attached to the cradle. Remove the ground strap lug from the rearmost stud. Replace in reverse order. Be sure to replace the ground strap on top of the flat washer on the rear stud.

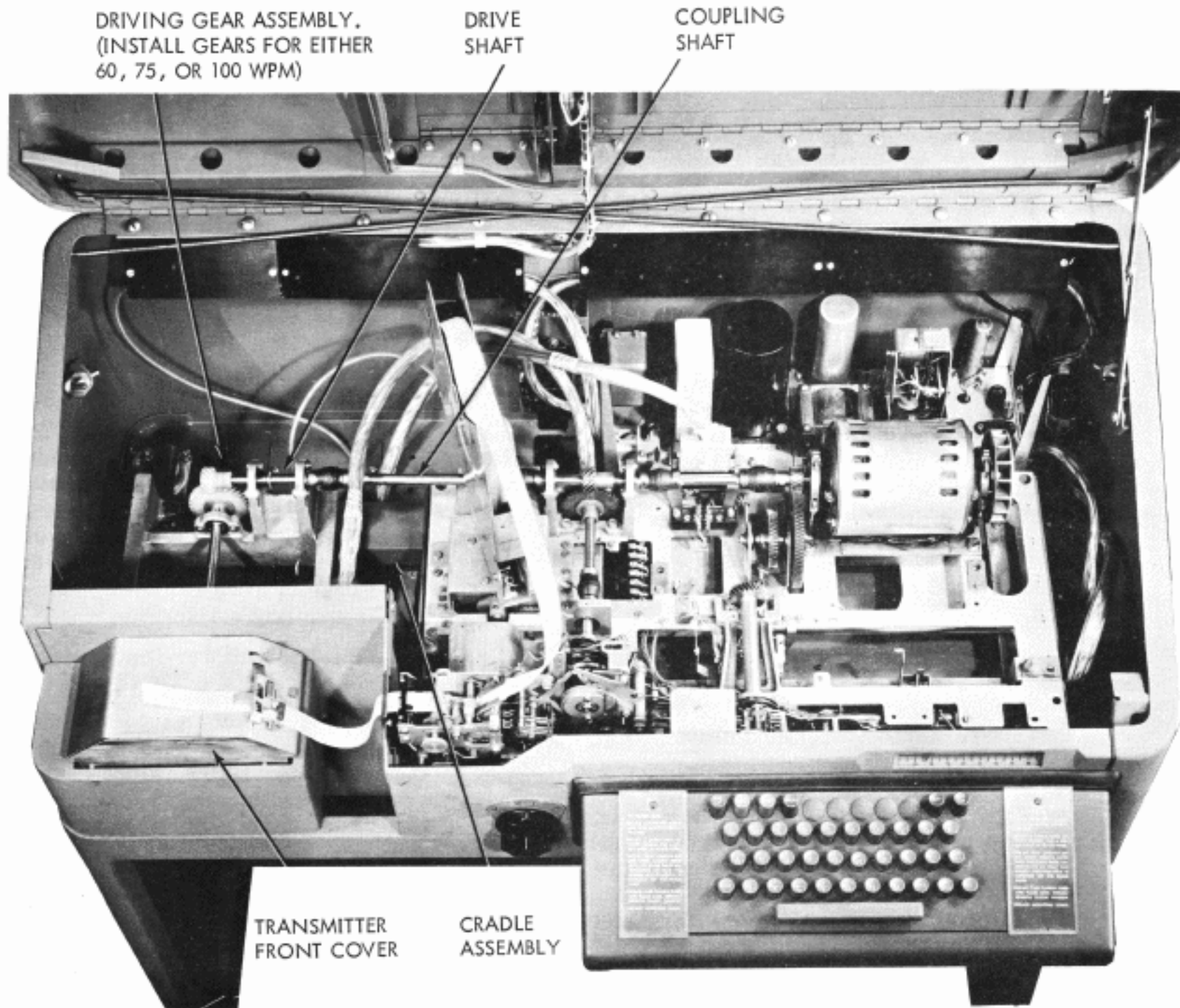

FIGURE 4-3. AUTOMATIC SEND-RECEIVE SET WITH TRANSMITTER DISTRIBUTOR BASE (LCXB)

4. DISASSEMBLY AND REASSEMBLY OF THE APPARATUS CABINET FOR HOUSING ONE OR TWO SELF CONTAINED TRANSMITTER DISTRIBUTOR UNITS - AC (Refer to Figure 4-4)

a. Mounting - For installations over a 4 inch square electrical duct, remove the duct covers from either side of the cabinet.

NOTE

The cabinet door may be arranged to open from the left or right side. Refer to the adjustment requirement should the cabinet be relocated and it is desired to swing the door in the opposite direction.

b. Transmitter-Distributor Unit - Disassembly and reassembly of the basic unit is covered in the preceding paragraphs except for minor variations which are self-explanatory.

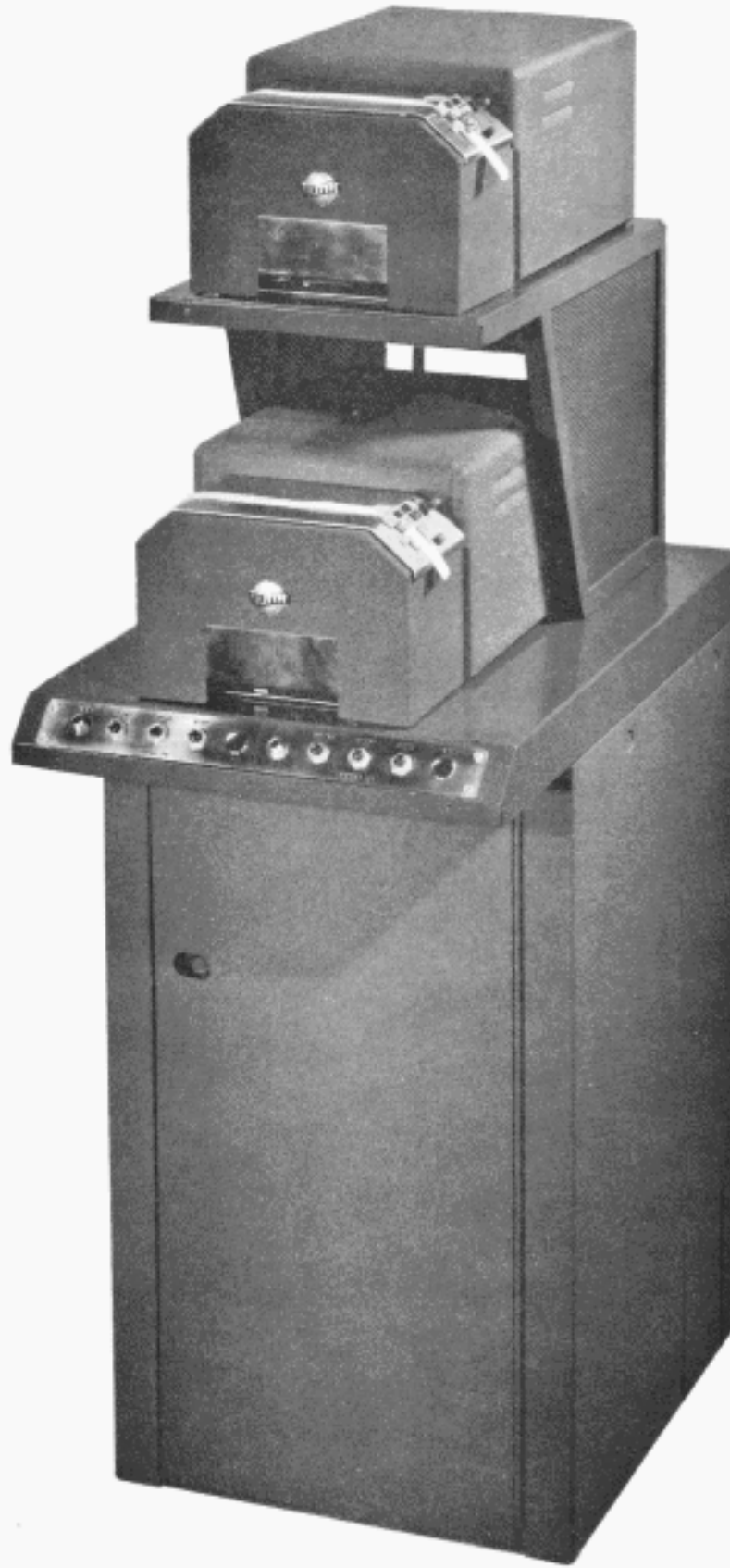

FIGURE 4-4. TRANSMITTER DISTRIBUTOR CABINET (AC)
FOR MOUNTING ONE OR TWO TRANSMITTER
DISTRIBUTOR (LBXD) UNITS.

5. DISASSEMBLY AND REASSEMBLY OF MULTIPLE MOUNTED TRANSMITTER-DISTRIBUTOR UNITS (Refer to Figures 4-5 and 4-6)

a. General

(1) To remove the transmitter distributor from the multiple base, open the hinged front portion of the cover to provide access to each transmitter and its attached cradle. Lift off the cover plate. Remove the clamp screw which anchors the cradle in its slide, then lift upward and pull forward to disengage the unit.

(2) Lift the cover upward and move toward the front.

b. Transmitter-Distributor Unit, Multiple Mounted

NOTE

Reference to right or left, etc. applies to the unit as mounted on the multiple base.

(1) Remove the two screws and lock washers which secure the electrical connector to the rear of the cradle. When the screws are replaced make sure that the head of each screw is on the outside of the cradle.

(2) Remove the two screws and lock washers that secure the casting to the rear of

cradle. Remove the screw, lock washer and nut that secures the casting to the front of the cradle. Note that the 158581 bushing is mounted with its hex head on the top side of the casting whereas on the self contained and the ASR application the bushing is inverted. Remove the cradle.

(3) Remove the screws, lock washers, and flat washers which secure the tape deflector to the top and filler plates.

(4) Remove the filler plate mounting screws.

(5) The disassembly of the basic unit is identical to that as described in paragraph 2, except for minor variations which are self-explanatory.

(6) Reassemble in the reverse order. Exercise care so as not to damage the cable, cable connector or switches.

c. Base for Multiple Arrangement

(1) Remove Motor Mounting screws without disturbing the shaft height unnecessarily.

(2) Disassemble the left end of the countershaft assembly by removing the 151659 screw, 121575 screw and three 153839 screws in the hub; do not allow the horseshoe retainer to fall off the shaft. When a speed change is to be made, replace with the appropriate gear.

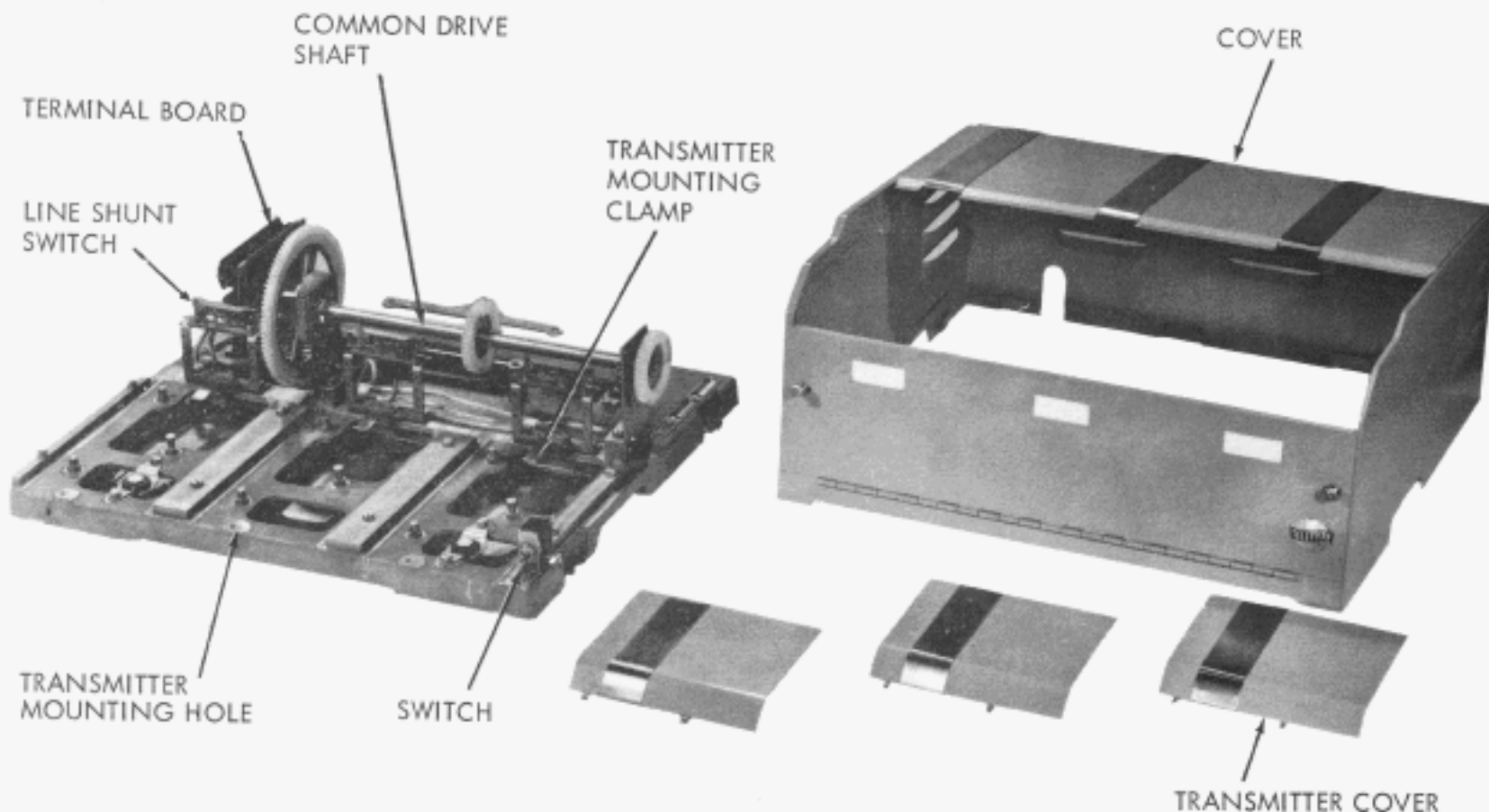

FIGURE 4-5. MULTIPLE TRANSMITTER DISTRIBUTOR BASE (LMXB) AND COVER

(3) Reassemble as follows: Place the 161512 retainer on the shaft to the right and adjacent to the left bearing. On the left side of the bearing, place the 112864 washer. Place the 161570 nut plate in the counterbore of the 162033 gear. On the other side of the gear place the 161564 spacer, driven gear and 161563 hub. Secure this assembly with three 153839 screws and 2191 lock washers (friction tight) and place on the shaft so that the 162033 gear is to the right of the driven gear. Tighten the three screws.

Next to the 161563 hub place the 112864 washer and secure the pile-up of parts with the 121575 screw, 2669 lock washer, and 84579 washer. Secure the hub to the shaft with the 151569 screw, 2191 lock washer, and 150432 flat washer. This assembly procedure must be followed to insure clamping the inner race of the bearing.

(4) Further disassembly is self-evident. Reassemble the entire unit in the reverse order (except paragraph (3) above).

DUMMY PLATE
(USED TO COVER A
VACANT
COMPARTMENT)

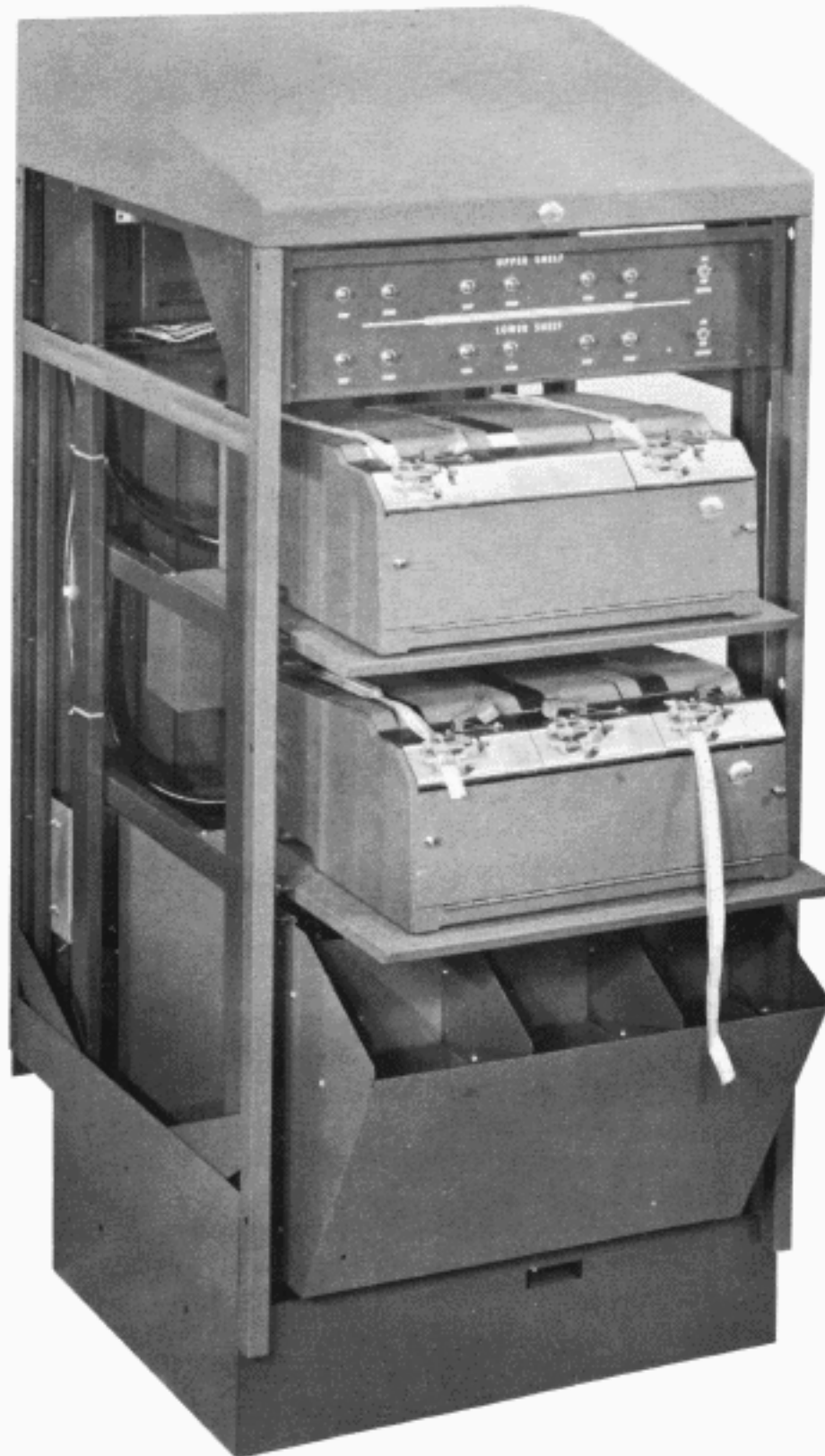

TAPE BIN

FIGURE 4-6. UNIVERSAL CABINET (LBAC) WITH TWO MULTIPLE TRANSMITTER DISTRIBUTOR SETS