

Bulletin No. 136
DECEMBER, 1928

MORKRUM-KLEINSCHMIDT

PRINTING TELEGRAPH SYSTEMS

*DESCRIPTION AND ADJUSTMENTS
OF THE
TYPEWHEEL TAPE PRINTER
(TICKER)*



MORKRUM-KLEINSCHMIDT CORPORATION
CHICAGO, U. S. A.

MORKRUM-KLEINSCHMIDT

PRINTING TELEGRAPH SYSTEMS

*DESCRIPTION AND ADJUSTMENTS
OF THE
TYPEWHEEL TAPE PRINTER
(TICKER)*



MORKRUM-KLEINSCHMIDT CORPORATION
CHICAGO, U. S. A.

I N D E X

	Page
GENERAL DESCRIPTION - - - - -	1
CODE - - - - -	1
DESCRIPTION OF PRINTER - - - - -	2
MOTOR CONTROL RELAY - - - - -	7
PRINTER ADJUSTMENTS - - - - -	8
Main Shaft Position, Fig. 1. - - - - -	8
Operating Cam Clutch Release Arm Position, Fig. 2. - - - - -	8
Selector Lever Spring Tension, Fig. 3. - - - - -	9
Selector Lever Guide Adjustment, Fig. 3. - - - - -	9
Selector Armature Pivot Screws Adjustment - - - - -	9
Armature Buffer Screws Adjustment - - - - -	10
Magnet Base Position, Fig. 4. - - - - -	10
Flutter Lever Spring Tension - - - - -	10
Transfer Bail Shaft Position - - - - -	11
Operating Cam Rollers Adjustment - - - - -	11
Cam Release Bail Position - - - - -	11
Cam Release Bail Spring Tension - - - - -	12
Transfer Lever Bearing Bracket Position, Fig. 5. - - - - -	12
Typewheel Stop Pin Spring Tension - - - - -	13
Typewheel Stop Arm Latch Spring Tension - - - - -	13
To Replace Typewheel Shaft Unit - - - - -	13
Typewheel Stop Unit Position - - - - -	13
Typewheel Stop Unit Centering Adjustment, Fig. 6. - - - - -	14
Transfer Bail Adjustment - - - - -	14
Motor Position Adjustment, Fig. 7. - - - - -	15
Feed Bail Spring Tension, Fig. 8. - - - - -	15
Pressure Wheel Lever Spring Tension, Fig. 9. - - - - -	16
Feed Ratchet Detent Lever Spring Tension, Fig. 10. - - - - -	16
Feed Pawl Arm and Space Blocking Arm Adjustment, Fig. 11. - - - - -	16
Feed Pawl Spring Tension, Fig. 11. - - - - -	17
Printing Hammers Adjustment - - - - -	17
Typewheel Shaft Adjustment, Fig. 12. - - - - -	17
Printing Bail Adjustment - - - - -	18
Hammer Backstop Adjustment, Fig. 13. - - - - -	18
Hammer Striker Spring Tension, Fig. 14. - - - - -	19
Tape Shield Adjustment - - - - -	19
Shift Lever Adjustment - - - - -	19
Typewheel Stop Arm Adjustment - - - - -	19
Tape Guide Position - - - - -	20
Selector Cam Friction Clutch Tension - - - - -	20
Operating Cam Friction Clutch Tension - - - - -	20
Typewheel Shaft Friction Clutch Tension - - - - -	21
MOTOR CONTROL RELAY UNIT ADJUSTMENT - - - - -	21
Motor Control Relay Bracket Adjustment - - - - -	21
Armature Stop Screws Adjustment, Fig. 16. - - - - -	21
Pole Piece Screws Adjustment - - - - -	21
Bias Spring Screw Adjustment, Fig. 16. - - - - -	21
Motor Contact Spring Tension, Fig. 16. - - - - -	21

I N D E X

	Page
Relay Mounting Bracket Adjustment, Fig. 16. - - -	22
Motor Contact Spring Adjustment, Fig. 16. - - -	22
Motor Control Cam Lever Spring Tension, Fig. 16.	22
GOVERNOR ADJUSTMENTS - - - - -	23
Speed Adjusting Wheel, Fig. 17.- - - - -	23
Adjusting Screw Guide Pin- - - - -	23
Governor Brush Springs, Fig. 18. - - - - -	23
Governor Brushes Position- - - - -	23
SPEED SETTING - - - - -	24
ORIENTATION - - - - -	24
LINE CURRENT - - - - -	24
OPERATING COIL RESISTANCE - - - - -	24

CHARACTER SENT

LINE SIGNALS		LETTERS CASE	LINE SIGNALS																				
START	STOP		START	STOP																			
1	2	3	4	5	6	START	1	2	3	4	5	6	STOP	START	1	2	3	4	5	6	STOP		
Black	White	Black	White	Black	White	Black	White	Black	White	Black	White	Black	White	Black	White	Black	White	Black	White	Black	White	Black	White
NOT USED						S	NOT USED						5	NOT USED									
NOT USED						P	NOT USED						.	NOT USED									
NOT USED						U	NOT USED						4	NOT USED									
NOT USED						I	NOT USED						9	NOT USED									
NOT USED						E	NOT USED						5	NOT USED									
NOT USED						A	NOT USED						1	NOT USED									
NOT USED						.	NOT USED						C	NOT USED									
NOT USED						F	NOT USED						6	NOT USED									
NOT USED						N	NOT USED						6	NOT USED									
NOT USED						K	NOT USED						NOT USED	NOT USED									
NOT USED						C	NOT USED						£	NOT USED									
NOT USED						D	NOT USED						3	NOT USED									
NOT USED						F	NOT USED						4	NOT USED									
NOT USED						J	NOT USED						0	NOT USED									
NOT USED						R	NOT USED						NOT USED	NOT USED									
NOT USED						Y	NOT USED						NOT USED	NOT USED									
NOT USED						H	NOT USED						3	NOT USED									
NOT USED						Q	NOT USED						4	NOT USED									
NOT USED						P	NOT USED						8	NOT USED									
NOT USED						Z	NOT USED						*	NOT USED									
NOT USED						T	NOT USED						NOT USED	NOT USED									
NOT USED						W	NOT USED						7	NOT USED									
NOT USED						L	NOT USED						8	NOT USED									
NOT USED						X	NOT USED						8	NOT USED									
NOT USED						M	NOT USED						2	NOT USED									
NOT USED						.	NOT USED						5	NOT USED									
NOT USED						V	NOT USED						8	NOT USED									
NOT USED						B	NOT USED						£	NOT USED									
NOT USED						O	NOT USED						RUBOUT	NOT USED									
NOT USED						&	NOT USED						3	NOT USED									
NOT USED						G	NOT USED						8	NOT USED									
NOT USED							NOT USED						2	NOT USED									
NOT USED							NOT USED						1	NOT USED									
NOT USED							NOT USED						B	NOT USED									
NOT USED							NOT USED						7	NOT USED									

— NOTE —
 BLACK BLOCKS INDICATE
 "MARKING" IMPULSES
 WHITE BLOCKS INDICATE
 "SPACING" IMPULSES

GENERAL DESCRIPTION

The Typewheel Tape Teletype is a motor driven telegraph printer. The characters which can be printed are molded in rubber on the rim of the typewheel. The printing is done on a paper tape 3/4 inch wide by pressing the tape against the characters on the typewheel. Letters are printed close to the upper edge of the tape while figures are printed near the lower edge of the tape. This printer is primarily intended for receiving stock quotations.

The operation of the printer is controlled by combinations of positive and negative impulses transmitted over the line wire to which the printer is connected. All of the operations of the printer are initiated by and the character to be printed is determined by movement of the armature of a polarized magnet actuated by the line impulses.

CODE

The signalling code employed to transmit characters is a six unit "Start-stop" code which consists of six selecting impulses used in various combinations of positive and negative intervals. Each group of six selecting impulses is preceded by a start impulse and followed by a stop impulse to maintain unison between the transmitting apparatus and the printers. Impulses which move the magnet armature toward the front of the printer are called marking impulses and those which move it in the opposite direction are spacing impulses. Figure shows graphically the code used, there being sixty four possible combinations.

OPERATION OF START-STOP SYSTEM

This printer is operated on the "start-stop" principle. The start and stop impulses cause the selector cam drum to revolve in unison with the transmitting distributor so that the character signals sent out by the transmitter may be properly received by the selecting mechanism and translated into letters and other characters.

The transmission of the start impulse, which is a spacing impulse, starts the selector cam drum revolving. The speed of rotation is such that when the transmitting distributor has revolved far enough to send out the first impulse, the selector cam drum has revolved to the proper position to receive it. When the transmitter has revolved to the position to send out the second impulse the selector cam drum also will have rotated to a similar position. At the end of the revolution after the sixth impulse has been received, the reception of the stop pulse stops the selector cam drum.

The selector cam drum is geared to rotate one-twelfth faster than the transmitter but it is so constructed that the distance from the position where it can receive one impulse and where it can receive the next impulse is one-twelfth greater than the distance between the position where the transmitting distributor can send out one impulse and the next one.

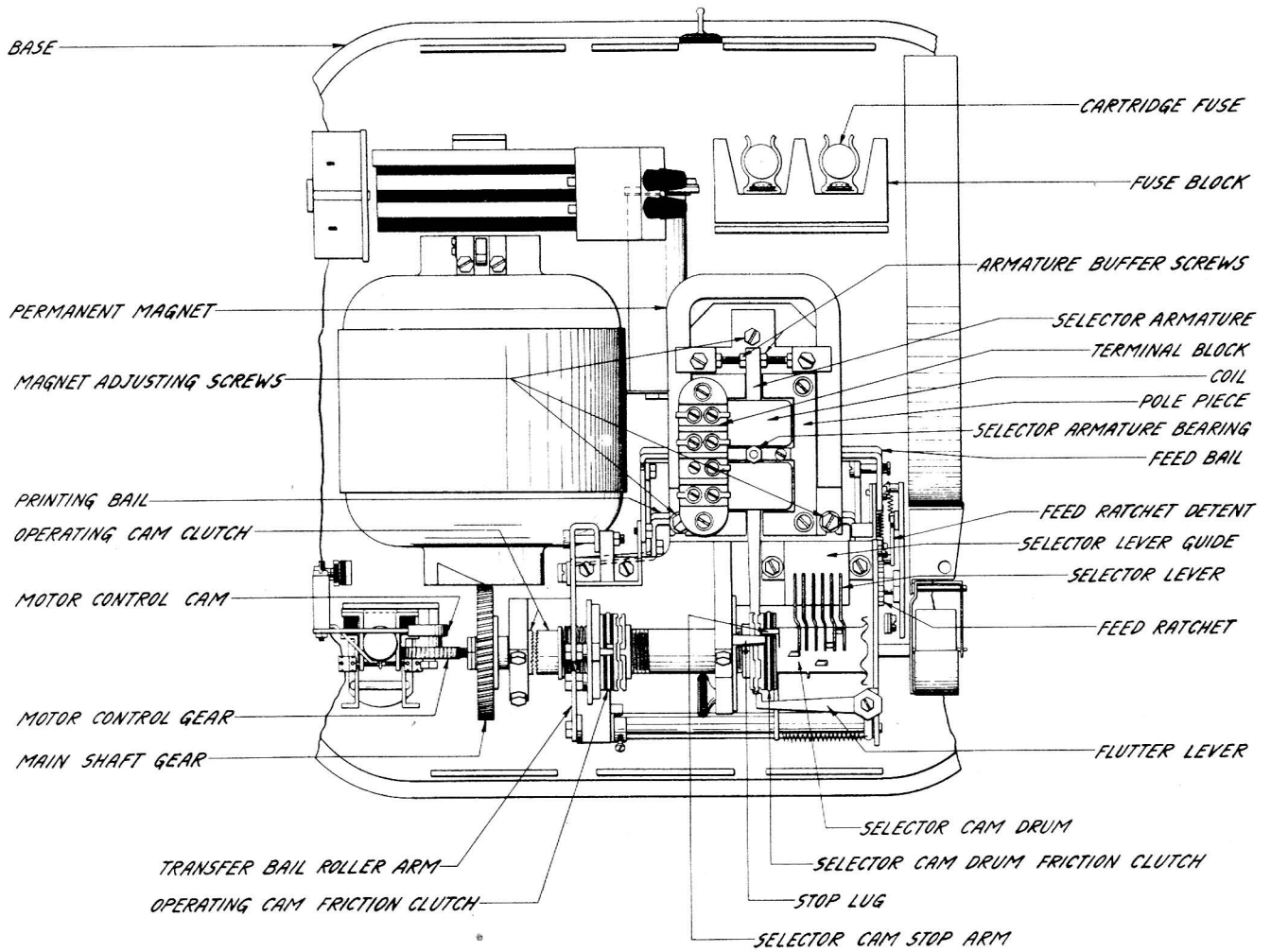

The reason that the selector cam drum is made to rotate one-twelfth faster than the transmitting distributor is this: It is not possible to maintain several units at exactly the same speed. In a short time even a slight speed difference would cause the transmitting mechanism and receiving mechanism to get out of unison so that when the transmitting distributor was sending out the first impulse of a character signal, the selector cam drum might be in a position to receive the second. This is avoided by arranging the selector cam drum to rotate faster than the transmitting distributor which allows it to complete its revolution sooner than the transmitting distributor completes the corresponding one. In other words, if the transmitting distributor has to travel 45° to get from the position where it sends out the first impulse to the position where it sends out the second, the selector cam drum must travel 48.3° to get from the position where it can receive the first impulse to the position where it can receive the second, but as the selector cam drum travels one-twelfth faster, it will reach this second position at the same time the transmitting distributor reaches its second position.

When the selector cam drum has completed a revolution it comes to a stop until the transmitting distributor again sends out a "start" impulse. Now, if the speed of the selector cam drum is slightly faster than its proper speed, the only effect will be that it will remain at rest slightly longer. If its speed is slightly slower than the proper speed, it will remain at rest just that much less time. Of course there will be a slight error in the position of the selector cam drum in the various positions but the mechanism is so constructed to provide for this, and due to the fact that the selector cam starts each revolution in unison with the transmitting distributor, this error does not become any greater.

DESCRIPTION OF PRINTER

The printer consists primarily of, a motor unit, a selector magnet unit, a main shaft unit, a typewheel shaft unit, a selector lever unit, transfer mechanism, printing mechanism and tape feed mechanism.

The motor unit consists of a motor with pinion and governor, a governor resistance and a condenser for governor contact protection.

The selector magnet unit consists of a selector armature, selector magnet coils, two pole pieces and a permanent magnet. The armature is pivoted so that the line signals passing through the coils will move the bent up end of the armature toward the rear of the printer on spacing impulses and toward the front on marking impulses. The armature acting in conjunction with the flutter lever determines the position of the selector cam drum.

The main shaft unit consists of a driving gear, main shaft clutch, operating cam, operating cam friction clutch, selector cam friction clutch, and selector cam drum.

The selector cam drum consists of a hollow cylinder with twelve cams projecting from its outer surface. Six of these cams are marking cams and six are spacing cams. Fastened to the rear end

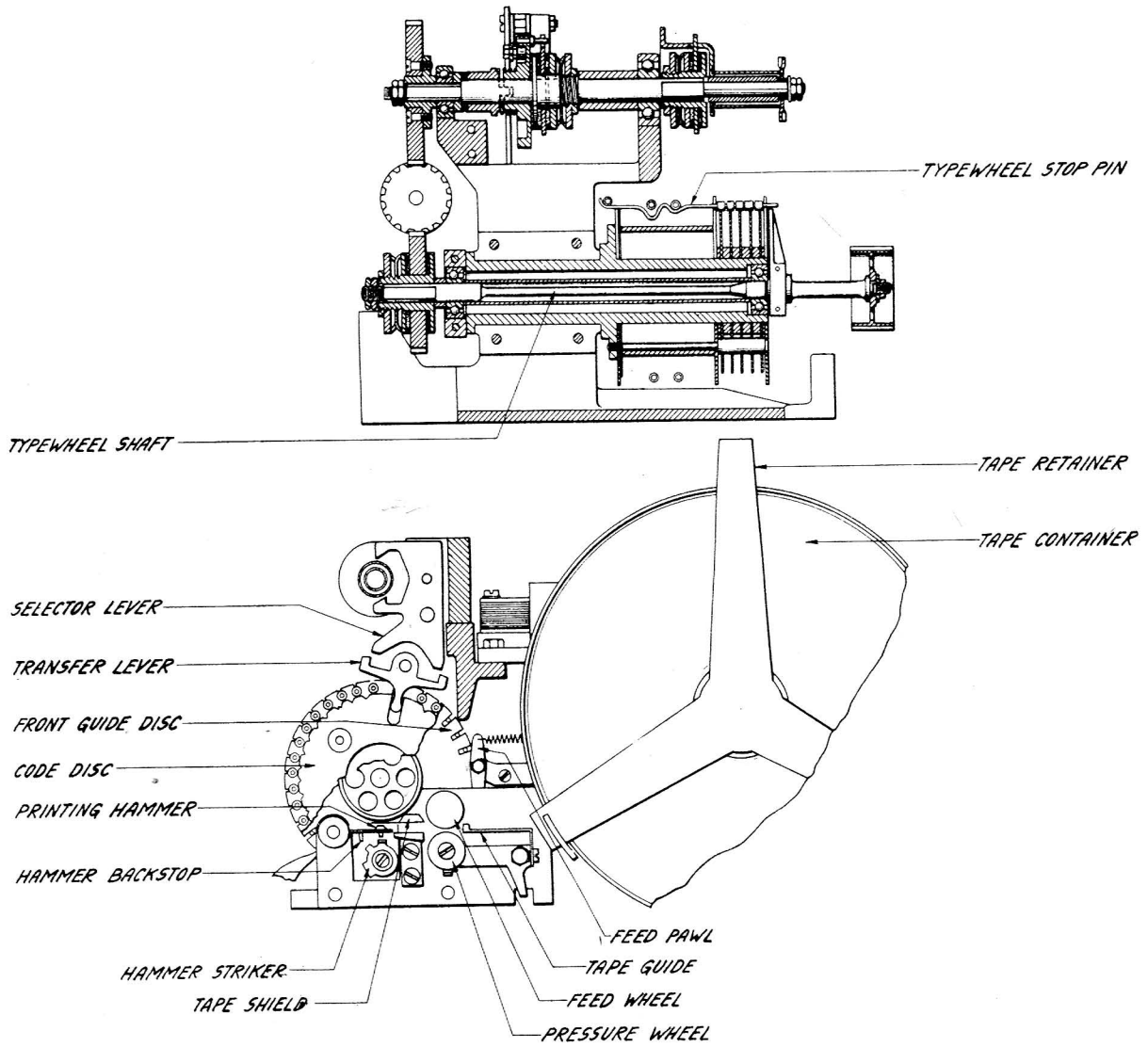

of the cylinder is an L shaped arm called the stop arm. Fastened to the front end of the cylinder is a crimped disc known as the flutter cam. There are fourteen crimps, seven projecting rearward and seven frontward. The flutter cam passes through the forked end of an L shaped lever called the flutter lever.

The selector cam drum slides back and forth on a sleeve on the main shaft between two stops. A spring attached to the flutter lever tends to move the cam drum against the front stop. The other arm of the flutter lever projects to the rear and can rest against the end of the selector armature when the armature is in the marking position. When the flutter lever is resting against the end of the armature and the cam drum is rotated, the drum will be moved backward and forward, by the action of the flutter cam, so that the marking cams will be in line with the marking (lower) arms of the selector levers at the instant that each cam is passing over the end of the corresponding marking arm. When the flutter lever is not against the end of the armature due to the armature being in the spacing position, the cam drum will remain against its front stop and the flutter cam will merely move the rearward projecting arm of the lever in and out. When the selector cam drum is against its front stop the spacing cams will line up with the spacing (upper) arms of the selector levers.

The stop arm attached to the rear end of the cam drum has a horizontal portion which passes through a slot in the selector friction disc, thus when this disc rotates the drum rotates with it. When the cam drum is nearing the end of its revolution and the stop signal is received, the flutter lever will be against the end of the armature and the cam drum will be moved to the rear. This will cause the arm to project far enough through the slot in the disc to be engaged by the stop lug on the orientation scale. When the start signal is received the armature will move to the spacing position, releasing the flutter lever and permitting the cam drum to move to its front stop. This will disengage the stop arm from the stop lug and the drum will revolve.

The marking cams are the series of six cams located spirally around the drum, the number one cam being the rearmost cam to the left of stop arm looking at the front of the printer with the stop arm up. The spacing cams are the series having the number one cam placed just to the right of the stop arm.

The operating cam is located to the rear of the selector cam drum. It is a combined internal and external cam, the transfer and printing bail rollers being controlled by the internal surface and the feed bail roller by the external surface. The operating cam is driven by two clutches. A friction clutch initiates the rotation and after the cam has rotated a few degrees a jaw clutch engages and carries the cam nearly to the end of the revolution where it is disengaged and the friction clutch continues to drive the cam until it is stopped by a projection on the cam striking against the cam release bail arm.

Shortly after the start of the rotation of the operating cam the printing bail roller rides to the peak of the cam thus rocking the printing bail and lifting the hammer striker against the printing

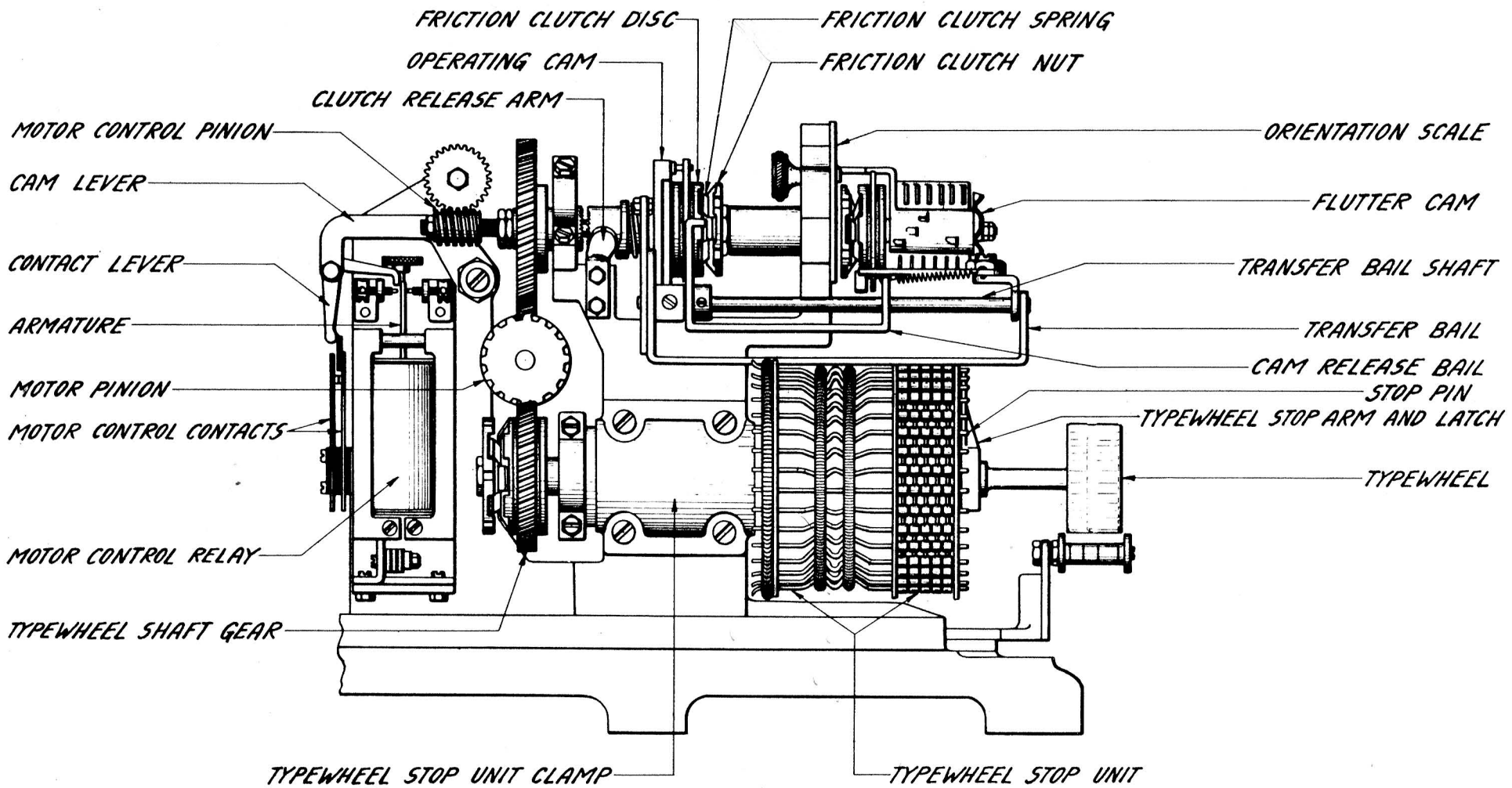

hammer which presses the tape against the typewheel, printing a character. As the printing bail roller rides down the cam, the transfer bail roller is riding up and as it reaches the peak, the transfer levers are forced against the selector levers and the selection set up in the selector levers is transferred to the code discs. While the transfer bail roller is riding to the peak of the internal cam the feed bail roller is riding up the external cam. The motion transmitted through the feed bail causes the feed pawl to move upward and engage the next tooth of the feed ratchet. Then as the roller rides down the cam the feed bail spring moves the feed pawl downward thus stepping the feed ratchet one tooth and through the medium of the feed wheel and pressure wheel moving the tape forward one letter space.

The selector lever unit is located to the right of the selector cam drum and holds the selector levers in a position so that they can be moved to either the spacing (up) or marking (down) position by the selector cams. The selector levers are mounted in slots in a guide. A flat spring is inserted in the slot with each selector lever to press the selector lever against the side of the slot to insure that it will remain where placed by the action of the corresponding selector cam.

The selector levers have four arms, the two upper arms being located one above and the other below the cam drum. The ends of these arms are offset with respect to each other, the lower or marking arm being offset toward the back and the upper or spacing arm being offset toward the front of the printer. This is done so that when the marking cams line up with the marking arms, the spacing cams will pass to the rear of the spacing arms, and when the spacing cams are in line with the spacing arms the marking cams will pass to the front of the marking arms.

The two lower arms of the selector levers are located above and in line with the transfer levers so that when the transfer levers are moved upward against the selector levers one arm of each transfer lever will strike against an arm of the corresponding selector lever, which arm depending upon whether the selector lever is in marking or spacing position. Thus the selection set up in the selector levers will be transferred to the code discs. It is to be noted that while there are six transfer levers there are only five code discs. The sixth transfer lever controls a shift mechanism which determines whether letters or figures shall be printed.

The typewheel shaft unit consists of a driving gear, typewheel shaft friction clutch, typewheel stop arm, typewheel and typewheel stop unit. The typewheel stop unit consists of code discs, stop pins and tension springs.

The five code discs which are part of the typewheel stop unit have a series of notches in their outer edges. At right angles to the code discs and equally spaced around their circumference are thirty two stop pins. These pins are held in slots in three guide discs, two to the rear and one to the front of the code discs. Tension springs press the pins against the edges of the discs. The friction is minimized by small rollers placed on the pins. The code discs

can be rotated slightly to either of two positions. The counter-clockwise position is the marking position while the opposite is the spacing position. With the code discs set in any particular combination the notches will be lined up in a certain position permitting the corresponding pin to move toward the center into the path of the typewheel stop arm, thus determining the letter to be printed. With the five discs there are thirty two possible combinations, thus any one of the thirty two stop pins can be selected and the typewheel stopped in any one of thirty two positions. Only thirty-one of these positions are utilized for characters, the thirty-second position, which corresponds to the all marking combination, having no character. The stop pin for this position is different from the others and not only stops the typewheel but prevents the tape from feeding. The typewheel is blank in this position. By the use of the shift mechanism it is thus seen that it is possible to print 62 characters. In this printer, however, some of the positions are not utilized.

The typewheel shaft is driven through the medium of a friction clutch. The typewheel and typewheel stop arm are fastened on this shaft so that when the typewheel is stopped to print a character, the friction clutch slips. The typewheel stop arm is equipped with a latch which passes over the end of the pin which is stopping the arm and engages with the opposite side of it preventing rebound.

Having described the functions of the various units and mechanism of the printer, it would now be well to follow through the complete operation of the printer in selecting and printing a character. Let us suppose that the letter "Y" is being transmitted. The transmitting distributor first sends out a start impulse which is always spacing. This impulse moves the selector armature to the spacing side and away from the flutter lever. This permits the flutter lever, by the action of its spring, to move the selector cam drum toward its front stop, disengaging the stop arm from the stop lug and initiating the rotation of the selector cam drum.

The next impulse is marking, which moves the selector armature to the marking side. As the cam drum rotates, the flutter lever will be moved outward permitting the selector armature to move into the path of the lever and block it. When the flutter lever is blocked by the selector armature, the flutter lever fork guides the flutter cam as it rotates so that the #1 marking cam on the drum will be moved into line with the marking arm of the #1 selector lever, and the cam will move the lever down to the marking position.

The next impulse is spacing. Therefore, the selector armature is moved to the spacing side, the flutter cam released and the cam drum permitted to move to its front stop. Thus, #2 spacing cam will be in line with #2 selector lever and as the drum revolves the #2 selector lever will be moved upward to the spacing position.

The third impulse being marking, the selector armature is again moved to the marking side and as the third marking cam approaches the marking arm of the third selector lever, the flutter cam will

move the flutter lever outward permitting the armature to slip under it and hold it. As the drum rotates further, the flutter lever being blocked, the flutter cam will cause the cam drum to be moved rearward and the third marking cam to come in line with the marking arm of the third selector lever and move it downward to the marking position.

The fourth impulse is spacing. Consequently the selector armature will be moved to the spacing side, releasing the flutter lever, permitting the #4 spacing cam to move the spacing arm on the #4 selector lever upward.

The fifth impulse is marking and consequently the selector armature will move to the marking side and in due course will block the flutter lever causing the fifth marking cam to move the fifth selector lever down.

The sixth impulse is spacing and consequently the sixth selector lever will be moved to the spacing position.

After the reception of the 6th selecting impulse, the stop impulse is received. As this impulse is always marking, the selector armature blocks the flutter lever and the cam drum will be moved to its rearward position and just as the rotation is completed the stop arm strikes against the stop lug and the cam drum is held at rest until the reception of the next start impulse.

During the rotation of the selector cam drum, and after the reception of the fourth impulse, a depression in the edge of the selector friction disc comes opposite the roller of the cam release bail. Through the action of the spring, this roller is pulled into the depression, the bail is rocked and the operating cam is released. The operating cam then starts to revolve. Shortly after the reception of the fifth pulse the operating cam is revolved far enough to operate the printing mechanism. However, the letter printed will not be the one just selected but a letter selected by the previous rotation of the cam drum. Following the sixth impulse, the operating cam has reached the position where it causes the operation of the transfer bail and thus the combination which has just been set up in the selector levers will be transferred to the code discs. The selector cam drum, of course, has now come to rest but the operating cam continues to revolve, causing the spacing of the tape for the previous letter before it completes its rotation and comes to rest against the cam release bail arm. The printing of the letter "Y", the selection of which has just been described, does not take place until the next selection is received and the cam drum has revolved far enough to release the operating cam.

When the selection was transferred to the code discs, the movement of these code discs in assuming their new positions moved outward the pin against which the typewheel stop arm was held, and permitted the stop arm to revolve until it struck against the "Y" pin which was permitted to move inward due to the notches in the code discs being in line in this position.

It will be seen from the above description that a letter which is selected during one revolution of the cam drum is not printed until the next revolution of the cam drum. In other words, while one character is being selected, the preceding character is being printed.

The typewheel shaft is geared to run 50% faster than the main shaft in order to allow plenty of time for it to rotate from one stop position to any other.

MOTOR CONTROL RELAY

The purpose of the motor control relay is to start and stop the printer motor. It is inserted in the signal line in series with the selector magnet coils. Its operation is as follows: The motor control pinion driving the motor control gear and cam causes the cam lever to move slowly up and down. The motor contact lever fastened to the cam lever is also moved up and down. When the armature of the relay is actuated by the line signals the contact lever can not be blocked by the armature. If the signal line is opened the tongue of the relay is held to the spacing side by a spring. As the cam lever is moved down by the cam, the contact lever is blocked by the top of the armature and pivoted so that the lower arm of the contact lever opens the motor contacts and stops the motor.

When the line is again closed the first marking impulse will energize the relay and move the armature away from the motor contact lever. The upper arm of the contact lever will then fall downward allowing the motor contacts to close starting the motor.

PRINTER ADJUSTMENTS

The following adjustments are arranged in a sequence that would be followed if a complete readjustment of the printer were undertaken. This fact should be kept in mind when a single adjustment is to be made.

MAIN SHAFT POSITION, FIG. 1.

With the selector armature to the spacing side rotate the motor governor until the selector cam drum stop arm is in front of the stop lug. Loosen the four main shaft bearing bracket screws and adjust the position of the main shaft so that there is from .004" to .006" space between the selector cam drum stop arm and the stop lug. After adjusting the shaft, tighten bracket screws.

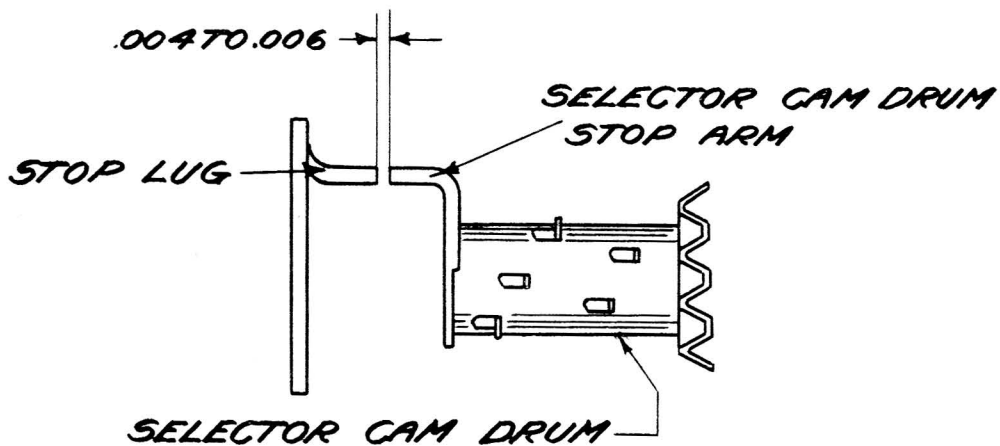

FIGURE 1.

OPERATING CAM CLUTCH RELEASE ARM POSITION, FIG. 2.

Rotate the motor governor until the operating cam is stopped by the cam release bail arm. Adjust the position of the clutch release arm by means of its clamping screws so that the clutch teeth are separated by from .005" to .015".

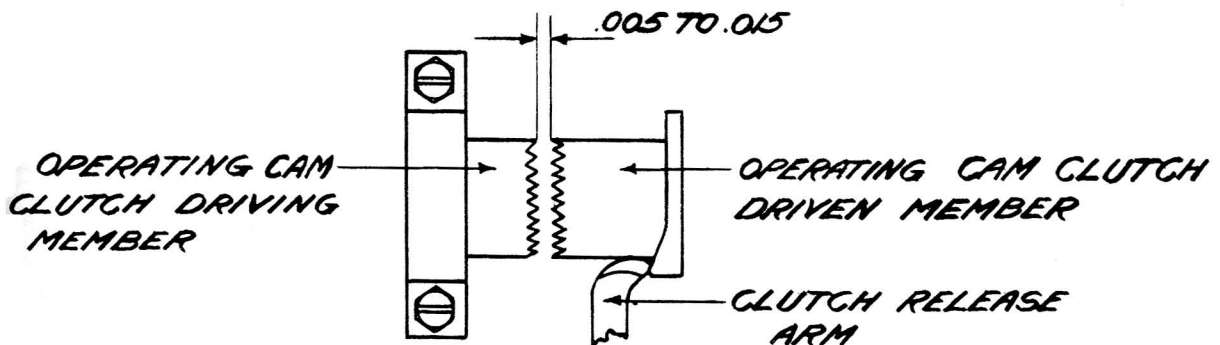

FIGURE 2.

SELECTOR LEVER SPRING TENSION, FIG. 3.

With the selector levers in the marking position (down against the stops) hook an 8 ounce scale under the selector lever at $\frac{5}{16}$ " from the end of the lever and pull upward. It should require from $2\frac{1}{2}$ to $3\frac{1}{2}$ ounces to start the lever moving. The correct tension is obtained by bending the springs as shown.

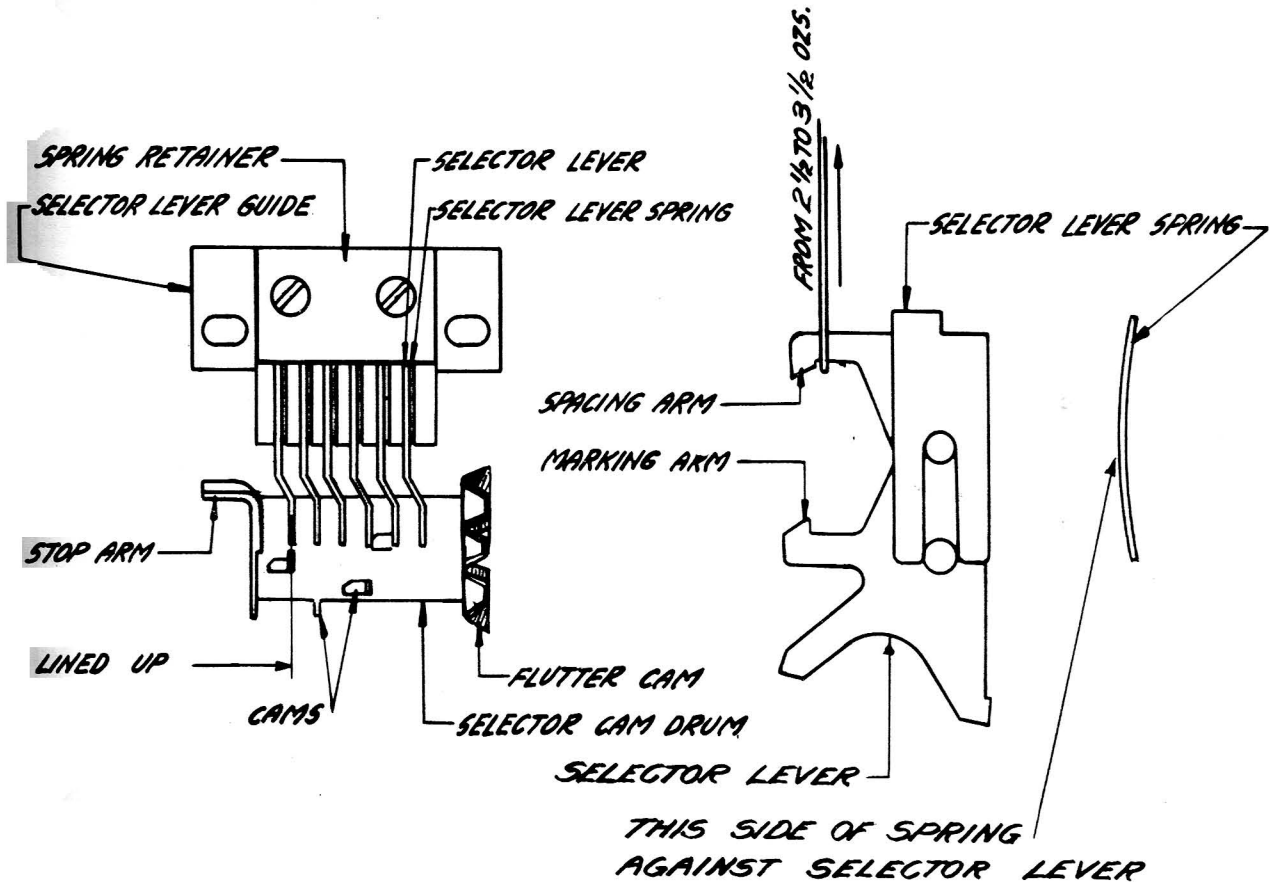

FIGURE 3.

SELECTOR LEVER GUIDE ADJUSTMENT, FIG. 3.

Loosen the selector lever guide mounting screws and adjust the position of the selector lever guide so that when the selector armature is held to the spacing side and the motor governor rotated the spacing cams on the selector cam drum will line up with the spacing arms of the selector levers. Tighten the guide mounting screws.

SELECTOR ARMATURE PIVOT SCREWS ADJUSTMENT.

Remove the permanent magnet and back off the armature buffer screws. Then adjust the up and down position of the selector armature by means of its pivot screws so that the top surface of

the armature is flush with the top surface of the left end of the pole pieces and also so that the selector armature is free and without play. After making this adjustment replace the permanent magnet so that the ends of the magnet are approximately 3/4" from the left end of the pole pieces.

ARMATURE BUFFER SCREWS ADJUSTMENT.

Adjust the armature buffer screws so that the armature will have .006" travel between the screws and so that the magnetism of the permanent magnet will hold the armature against either buffer screw. When making this adjustment be sure that the armature is not touching the flutter lever.

MAGNET BASE POSITION, FIG. 4.

Loosen the magnet base mounting screws and the eccentric stop screws. Move the eccentric stop away from the magnet base. With the selector armature to the spacing side rotate the motor governor until the selector cam stop arm has just passed the stop lug. Place the selector armature on the marking side and the flutter lever against the end of the armature. Then adjust the position of the magnet base so that when the governor is turned the marking cams on the selector cam drum line up with the marking arms of the selector levers. (See "A", Fig. 4). Now pivot the magnet base on the front mounting screw so that there is from .002" to .004" space between the side of the selector armature and the end of the flutter lever when the selector armature is on the spacing side and the flutter lever is in the spacing position. (See "B", Fig. 4). Recheck the alignment of the marking cams and the marking arms of the selector levers. Tighten the mounting screws. Set the eccentric stops against the magnet base and tighten screws.

With the selector armature held to the spacing side rotate the motor governor until the selector cam stop arm has just passed the stop lug. Hold the selector armature to the marking side and rotate the governor. There should be at least .004" clearance between the selector armature and the flutter lever when the flutter lever is on each high part of the flutter cam and the selector cam drum is on the spacing side. (See "C", Fig. 4). Should this clearance be less than .004" for any high part of the cam, recheck the magnet base position.

FLUTTER LEVER SPRING TENSION.

With the flutter lever against the end of the selector armature hook an 8 ounce scale over the lever in back of the spring hole and pull in line with spring. It should require from 6 to 7 ounces to just start the flutter lever moving.

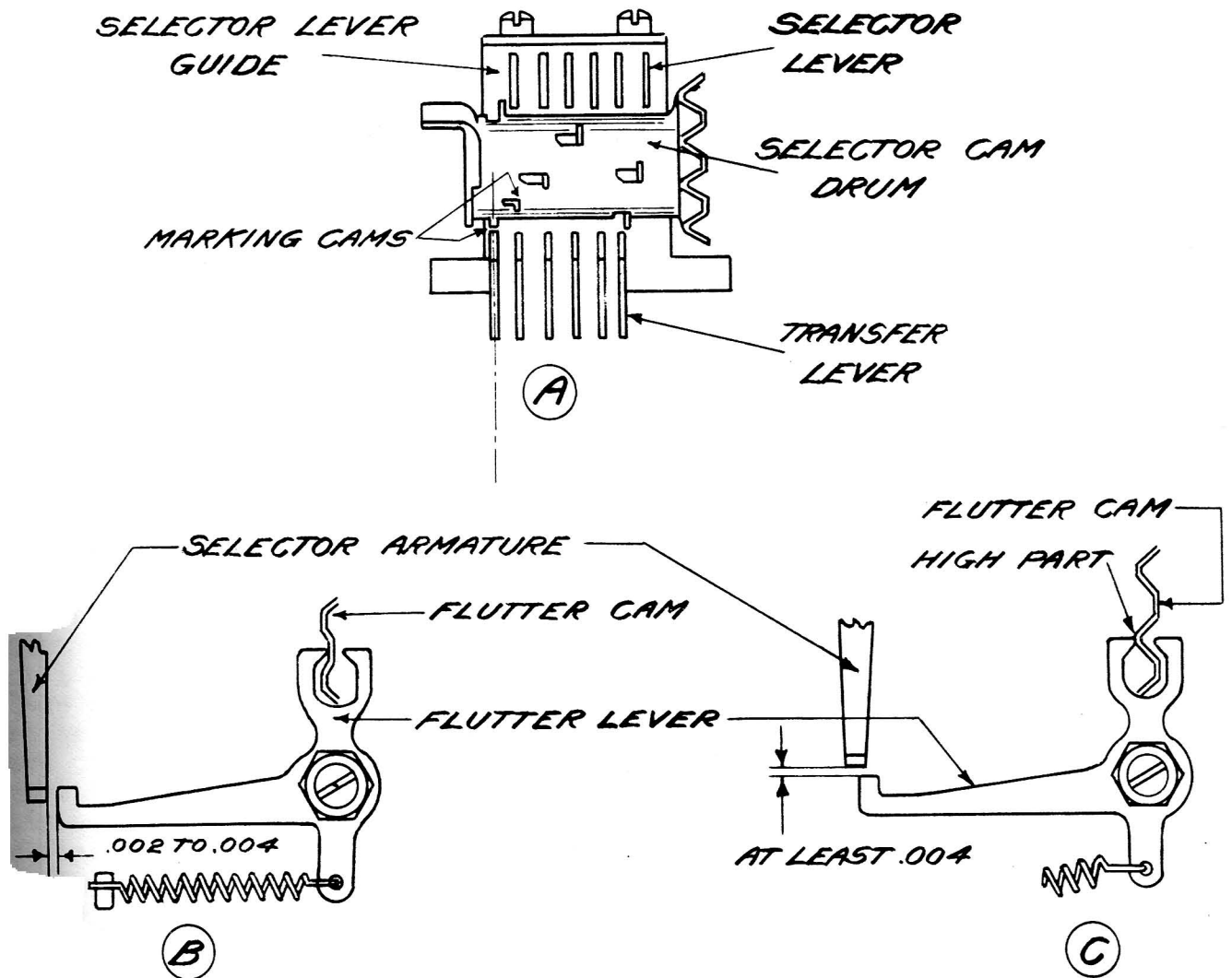

FIGURE 4.

TRANSFER BAIL SHAFT POSITION.

Loosen the transfer bail shaft set screws and set the shaft so that the right end of the shaft projects beyond the side of the transfer bail approximately $1/16$ ".

OPERATING CAM ROLLERS ADJUSTMENT.

Adjust the feed bail roller, printing bail roller and the transfer bail roller by means of their bearing screws and nuts so that the rollers turn freely and have no play.

CAM RELEASE BAIL POSITION.

Remove the flutter lever spring and loosen the bail collar screw. Set the collar so that the bail has from $.002$ " to $.004$ " play between the collar and casting.

CAM RELEASE BAIL SPRING TENSION.

With the cam release bail roller resting on the cam, hook a 32 ounce scale in the spring hole and pull in line with the spring. It should require from 10 to 16 ounces to just start the bail moving. Replace the flutter lever spring.

Remove the four screws and clamp holding the typewheel shaft unit to the main casting and remove the unit from the printer. Loosen the transfer bail arm clamping screws.

TRANSFER LEVER BEARING BRACKET POSITION, FIG. 5.

Loosen bracket clamping screws. The bracket may now be moved in all directions. First set the lateral position of the bracket, as described under "A".

A. With the transfer bail held in the "upward" position set the transfer bracket so that both arms of the transfer levers line up with the selector levers.

B. With the selector armature on the marking side and the flutter lever against the end of the selector armature, rotate the governor until the selector cam stop arm is resting against the stop lug. Place all selector levers in the marking position (down). Raise the transfer bracket and check the bite that the transfer levers have on the selector levers. Then set the selector levers in the spacing position (up). Raise the transfer bracket and check the bite on the spacing side. Now shift the bracket forward or backward so that the bite on the spacing side is equal to the bite on the marking side. Tighten bracket clamping screws. Recheck adjustment "A"

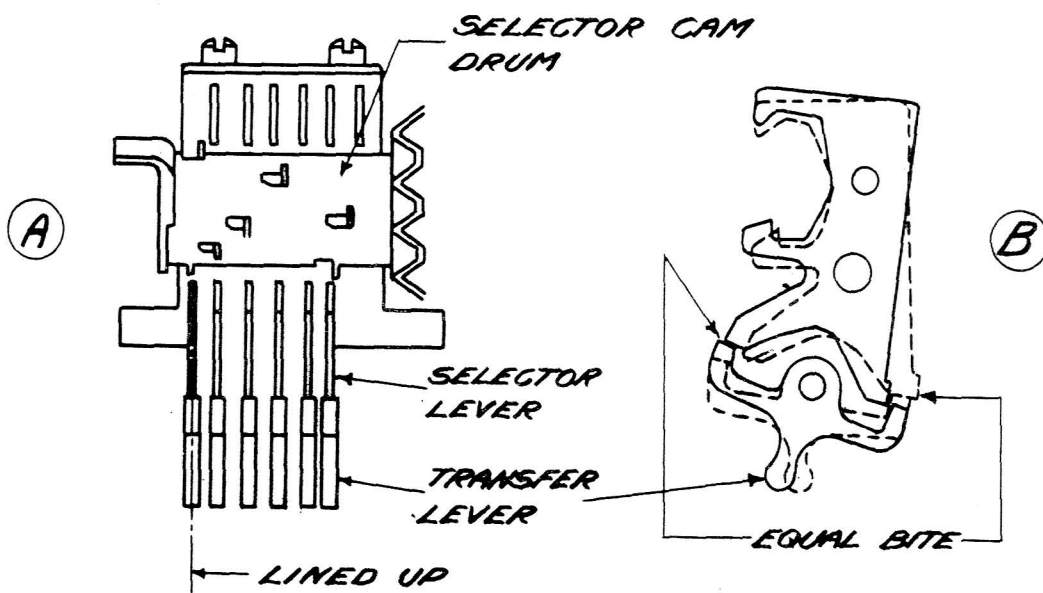

FIGURE 5

TYPEWHEEL STOP PIN SPRING TENSION.

Hold the typewheel stop unit in a horizontal position. Hook an 8 ounce scale over the front end of the stop pin and pull vertically in line with the slot. It should require from 2 to 4 ounces to just start the stop pin moving. Tension of rub-out bar is taken in the same manner. Scale should read from 4 to 7 ounces. The ends of the typewheel stop pin springs should be hooked together in the open space between the pins and in line with the code disc slots.

TYPEWHEEL STOP ARM LATCH SPRING TENSION.

With the typewheel shaft unit in a vertical position hook an 8 ounce scale over the end of the stop arm latch and pull at a right angle to the latch. It should require from 1 to 2 ounces to just start the latch moving.

TO REPLACE TYPEWHEEL SHAFT UNIT.

With the selector armature on the spacing side rotate the motor governor until the selector stop arm has just passed the stop lug. Place the selector armature on the marking side and the flutter lever against the end of the armature. Rotate the motor governor until the transfer arm roller is on the high part of the operating cam. Set the position of the code disc slots so that they are in line. Replace the type wheel shaft unit so that the transfer levers are in their respective code disc slots. Replace the unit clamp and tighten screws.

TYPEWHEEL STOP UNIT POSITION.

- A. With the selector armature on the spacing side rotate the motor governor until the transfer bail roller is at the place where it just starts to ride up the cam.
- B. Loosen the typewheel stop unit clamping screws sufficiently to permit the unit to be shifted horizontally.
- C. Adjust the horizontal position of the unit so that the transfer levers line up with their respective code discs.
- D. Move #1, #3 and #5 selector levers to the spacing position (up against the stops) and #2, #4 and #6 selector levers to the marking position (down against the stops). Move the #1, #3 and #5 code discs to the spacing position (clockwise) and #2, and #4 code discs to the marking position (counter-clockwise). Now continue rotating the motor governor until the locating mark on the operating cam is at its nearest point to the transfer bail arm roller. Force the transfer bail up by hand and at the same time rotate the typewheel stop unit in a clockwise and counter-clockwise direction until the arm on each transfer lever is against the arm of its respective selector lever. While holding the transfer bail up tighten the transfer bail arm clamping screws and the stop unit clamping screws.
- E. Recheck the horizontal position of the stop unit.

TYPEWHEEL STOP UNIT CENTERING ADJUSTMENT, FIG. 6.

With armature on the marking side and the flutter lever against the end of the armature rotate the motor governor until the selector cam stop arm is against the stop lug and the operating cam is stopped by the cam release arm. Place the code discs in the spacing position (clockwise) and operate the selector levers by hand so that the edge of the marking arms of the selector levers are just opposite the edges of the transfer levers. (See "A", Fig. 6). Note the space between the edges. Then move the code discs to the marking position (counter-clockwise) and operate the selector levers by hand so that the edges of the spacing arms of the levers are just opposite the edges of the transfer levers. (See "B", Fig. 6). If this space between the edges is not equal to the space between the edges on the other side, loosen the typewheel stop unit clamping screws sufficiently to permit the unit to be rotated and turn the stop unit so that the two spaces referred above are equal.

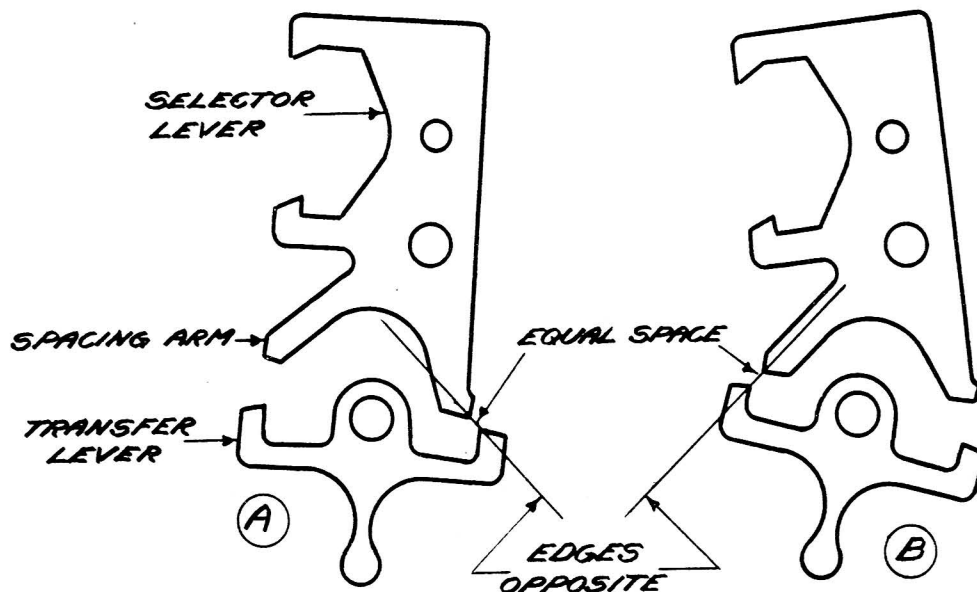

FIGURE 6

TRANSFER BAIL ADJUSTMENT.

With the selector cam stop arm against the stop lug and the operating cam stop arm against the release bail arm, move the selector armature to the spacing side and turn the motor governor until the locating mark on the operating cam is at its nearest point to the transfer bail roller. Loosen the transfer bail arm clamping screws. Place #1, #2 and #3 selector levers in the spacing position (up against the stops) and #4, #5 and #6 selector levers in the marking position (down against the stops). Place #1, #2 and #3 code discs in the spacing position (clockwise) and #4 and #5 code discs in the marking position (counter-clockwise). Now hold the transfer bail arm so that the roller is against the cam and at the same time hold

the transfer bail operated so that the transfer levers are up securely against their respective selector levers. Tighten the transfer bail arm clamping screws.

MOTOR POSITION ADJUSTMENT, FIG. 7.

By means of the motor adjusting nuts move one end of the motor up or down so that there is a slight amount of play between the motor pinion and the main shaft gear. (Not more than .002"). Tighten motor mounting screws and nut.

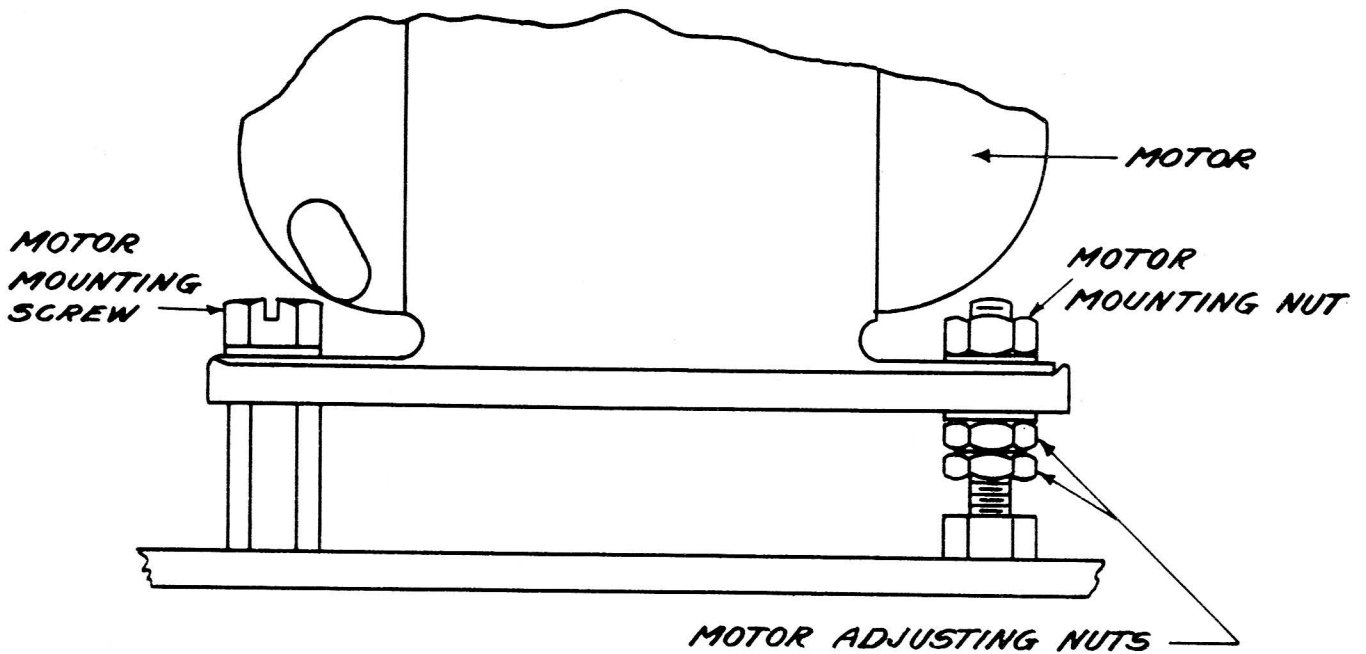

FIGURE 7

FEED BAIL SPRING TENSION, FIG. 8.

Remove the feed pawl spring. With the feed bail roller on the low part of the cam hook a 32 ounce scale over feed pawl bearing screw and pull vertically. It should require from 18 to 24 ounces to start the feed bail moving. Replace the feed pawl spring.

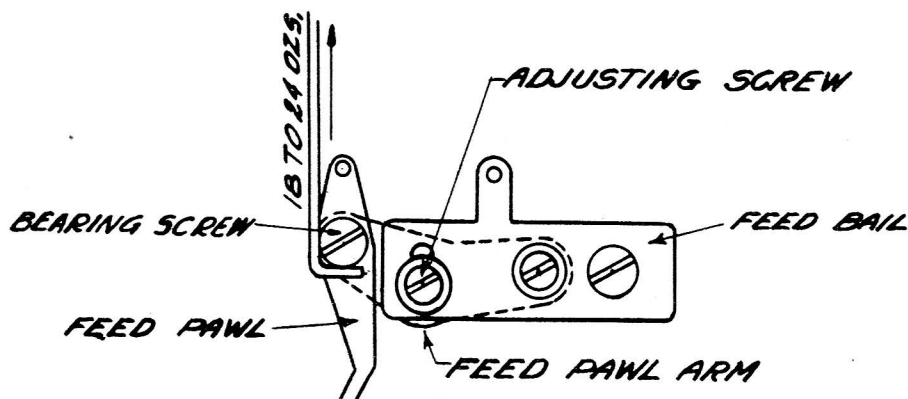

FIGURE 8.

PRESSURE WHEEL LEVER SPRING TENSION, FIG. 9.

Hook a 32 ounce scale over the spring arm of lever and pull in line with spring. It should require from 12 to 16 ounces to just start the lever moving.

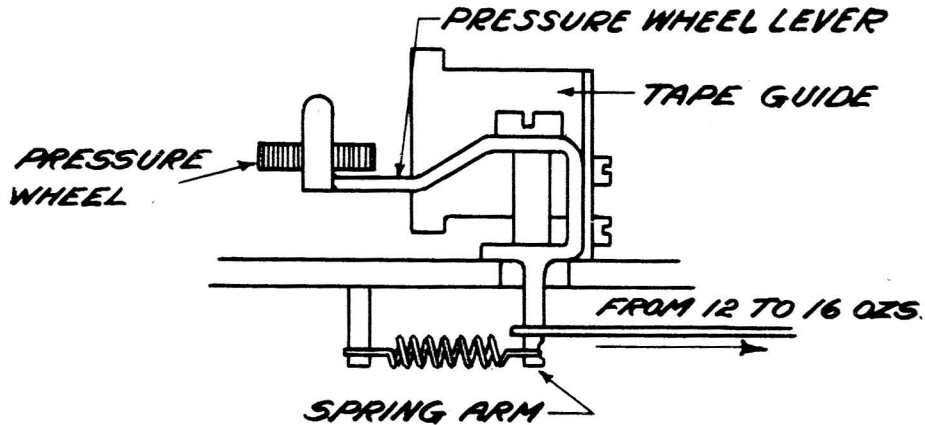

FIGURE 9

FEED RATCHET DETENT LEVER SPRING TENSION, FIG. 10.

Hook a 32 ounce scale in the spring hole of detent lever and pull in line with spring. It should require from 8 to 12 ounces to just start the lever moving.

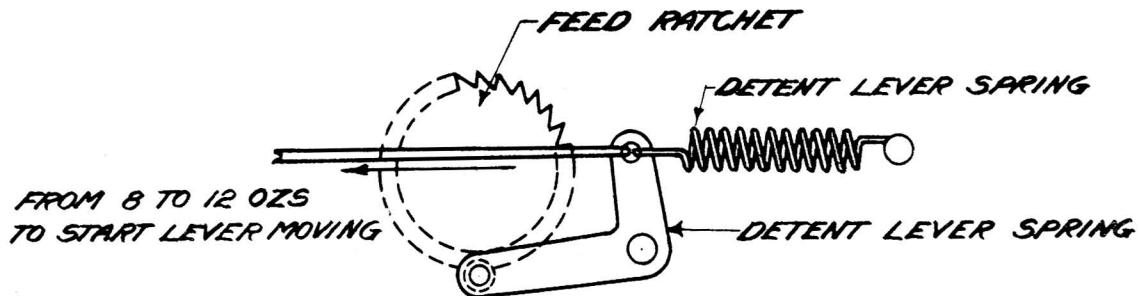

FIGURE 10

FEED PAWL ARM AND SPACE BLOCKING ARM ADJUSTMENT, FIG. 11.

With the selector armature on the spacing side rotate the motor governor until the transfer bail roller is at the place where it just starts to ride up the cam. Move all selector levers to the marking position (down against the stops) and rotate all the code discs to the marking position (counter-clockwise) so that the rub-out bar is selected. Now continue rotating the motor governor (about one-half revolution) until the feed bail roller is on the

high part of its cam.

Loosen the two screws holding the feed pawl arm and the space blocking arm. Set the position of the space blocking arm so that the arm overlaps the selected rub-out bar by from .020" to .040" and also so that there is a clearance of from .010" to .030" between the blocking arm and the rub-out bar. Then, before tightening the screws and without disturbing the position of the blocking arm, set the position of the feed pawl arm so that the end of the pawl over-travels the tooth that is in the horizontal center of the feed ratchet wheel by from .045" to .060" (approximately 1/2 tooth). Tighten the screws.

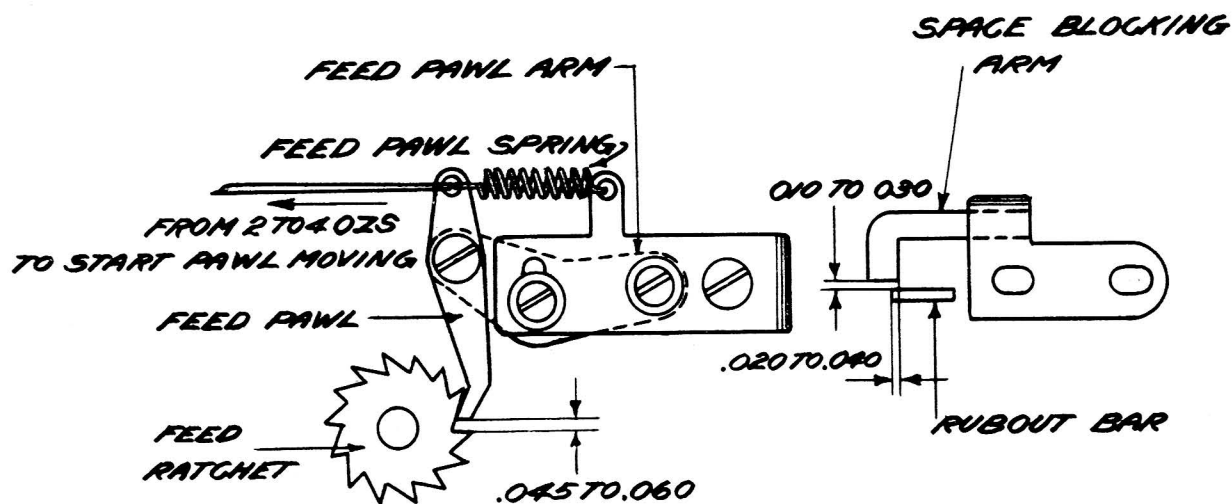

FIGURE 11.

FEED PAWL SPRING TENSION, FIG. 11.

Hook an 8 ounce scale in spring hole of the feed pawl and pull in line with the spring. It should require from 2 to 4 ounces to just start the pawl moving.

PRINTING HAMMERS ADJUSTMENT.

Remove the typewheel. Adjust the position of the printing hammers by means of shims between the printing hammer stud nut and the rear tape guide flange so that the sides of the strip between the two openings in the tape shield are equally distant from the sides of the letters and figures printing hammers when the printing hammers are flush against the separator collar. Replace the typewheel.

TYPEWHEEL SHAFT ADJUSTMENT, FIG. 12.

Adjust the position of the typewheel shaft by means of its bearing bracket so that the space between the upper and lower case characters on the typewheel lines up with the strip between the two openings in the tape shield.

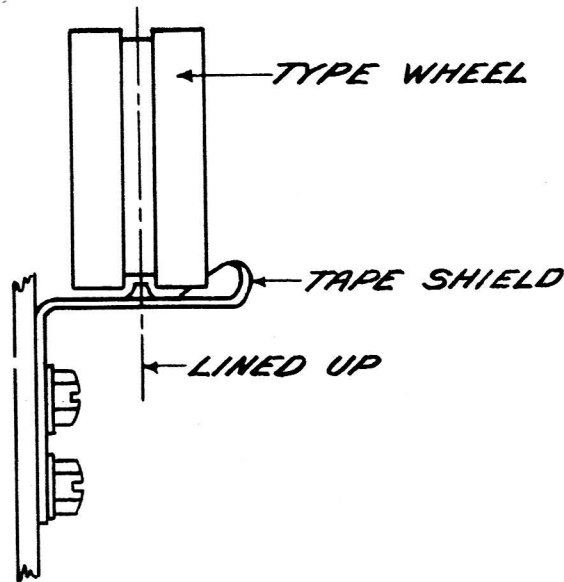

FIGURE 12.

PRINTING BAIL ADJUSTMENT.

Loosen printing link eccentric screw nut and turn eccentric screw so that the printing link is midway between its upper and lower adjusting limits. With the selector armature on the spacing side turn the motor governor until the printing arm roller is on the high part of the operating cam. Loosen the printing link clamping screws and set the position of the printing bail so that when the printing hammer striker is in the "figures" position the "figures" printing hammer is lightly touching a "figures" character on the typewheel.

HAMMER BACKSTOP ADJUSTMENT, FIG. 13.

Loosen the tape shield mounting screws and the printing hammer stud nut and adjust the hammer back stop so that when the hammers are resting lightly against a character on the typewheel there is from .020" to .030" between the hammers and the hammer back stop. Tighten the screws.

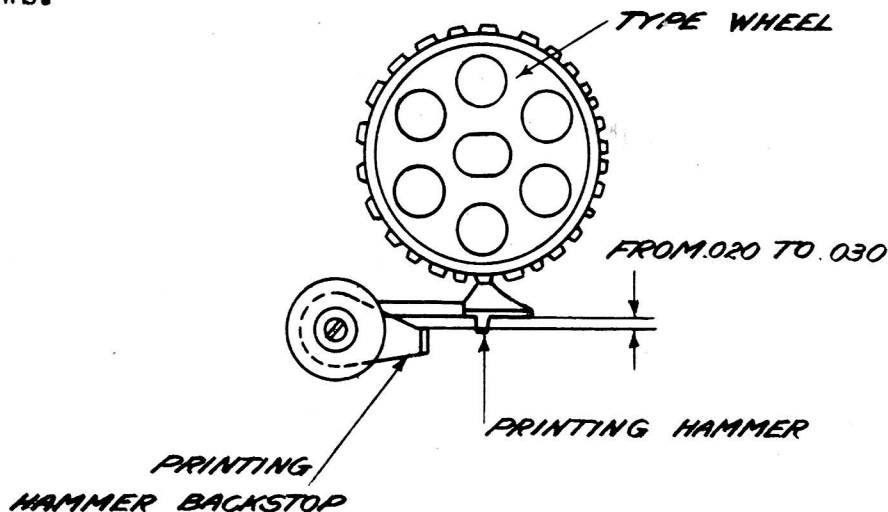

FIGURE 13

HAMMER STRIKER SPRING TENSION, FIG. 14.

With the hammer striker in the "figures" position hook an 8 ounce scale over the "figures" arm of the hammer striker and pull horizontally. It should require from 4 to 6 ounces to pull striker from "figures" to "letters" position.

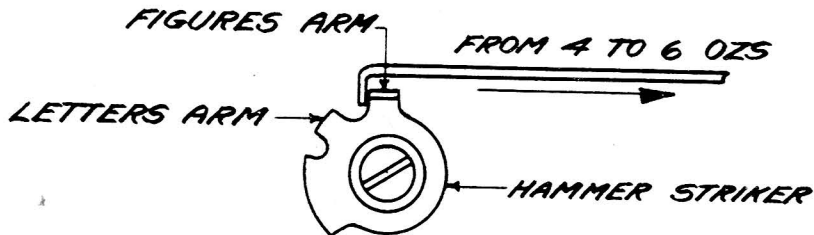

FIGURE 14

TAPE SHIELD ADJUSTMENT.

Set the position of the tape shield by means of its clamping screws so that the strip between the two openings in the tape shield is from .008" to .015" away from the section of the typewheel between the upper and lower case characters.

Care should be taken when making this adjustment that the shield is in a horizontal plane and that the printing surfaces of the printing hammers pass through the middle of the openings in the tape shield.

SHIFT LEVER ADJUSTMENT.

With the transfer bail roller on the low part of the operating cam shift the code discs so that they are in the spacing position (clockwise). Loosen the shift lever set screws and adjust the shift lever so that when the print hammer striker arm is against the "letters" stop the bottom of the shift transfer lever is in line with the bottom of the other transfer levers. Tighten the screws.

TYPEWHEEL STOP ARM ADJUSTMENT.

Move the #3 and #5 code discs to the marking side (counter-clockwise) and #1, #2 and #4 code discs to the spacing side (clockwise). This will select the "H" stop pin. Loosen the typewheel stop arm clamping screw and set the position of the stop arm on the shaft so that the arm latch has a bite of one-half its thickness on the selected stop pin. Hold the stop arm against the pin and rotate the shaft until the "H" on the typewheel will be in a position to print on the tape. Recheck the bite of the latch on the stop pin and tighten the stop arm clamping screw.

TAPE GUIDE POSITION, FIG. 15.

Loosen the tape guide screws and set the tape guide so that its top surface is horizontally in line with the top of the tape pressure wheel, and also so that the guide is in line with the tape guide flanges.

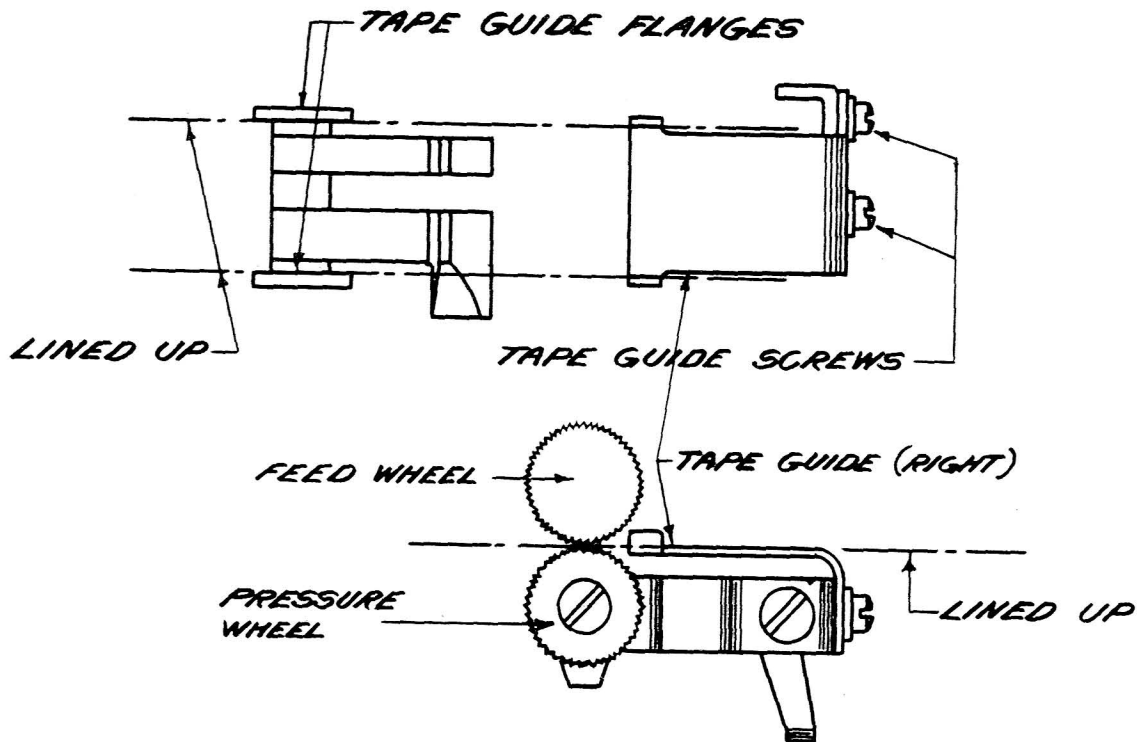

FIGURE 15

SELECTOR CAM FRICTION CLUTCH TENSION.

Move the orientation scale so that the range mark is at 120 on the scale. Take the clutch tension with the motor running and the selector cam stop arm against the stop lug. Hook a 32 ounce scale over the selector cam stop arm and pull horizontally. It should require from 20 to 28 ounces to just start the stop arm moving away from the stop lug.

OPERATING CAM FRICTION CLUTCH TENSION.

Take this tension with the motor running and the operating cam stop lug against the cam release arm. Hook a 32 ounce scale over the operating cam friction clutch drive pin and pull up vertically. It should require from 14 to 20 ounces to just start operating cam stop lug moving away from the cam release arm.

Precaution: When taking this tension be sure to hold the selector armature to the marking side because if the operating cam stop lug is permitted to pass the cam release arm the cam driven clutch will engage with the drive clutch causing the hand to be pulled to the printer and injury may result.

TYPEWHEEL SHAFT FRICTION CLUTCH TENSION.

Take this tension with the motor running and the typewheel stop arm against the selected "E" stop pin. (#1 code disc marking and #2, #3, #4, #5 and #6 code disc spacing). Lift the typewheel stop arm latch out of its guide slot and hook a 32 ounce scale in the guide slot. Pull horizontally. It should require from 14 to 20 ounces to just start the stop arm moving away from the "E" stop pin.

MOTOR CONTROL RELAY UNIT ADJUSTMENTS.

MOTOR CONTROL RELAY BRACKET ADJUSTMENT.

Adjust the motor control relay bracket by means of its mounting screws so that there is a slight amount of play between the motor control gear and worm. (Not more than .002").

After adjusting the relay bracket bend the relay terminals so that the terminals clear the base by at least 1/8".

ARMATURE STOP SCREWS ADJUSTMENT, FIG. 16.

Back off the armature stop screws, the pole piece screws and turn the bias spring screw so that the bias spring does not touch the armature.

Check to see that the armature stands straight in a centering position and is free from binds when moved to either side.

Turn the right hand stop screw until it just touches the armature. Then turn in the left hand stop screw so that when the armature is resting against the right hand stop screw, there is .008" space between the armature and the left hand stop screw.

Turn out the right hand stop screw so that when the armature is resting against the left hand stop screw there is .015" space between the armature and the right hand stop screw.

POLE PIECE SCREWS ADJUSTMENT.

With the armature against the right hand stop turn in the right hand pole piece screw until there is .004" (measured with a piece of printer tape) between the pole piece and the armature.

With the armature against the left hand stop turn in the left hand pole piece until there is .004" space (measured with a piece of printer tape) between the pole piece and the armature.

BIAS SPRING SCREW ADJUSTMENT, FIG. 16.

Turn the bias spring screw until the bias spring moves the armature against the left hand stop. When making this adjustment check to see that the bias spring screw is tight enough to prevent the screw being turned by the vibration of the printer in operation.

MOTOR CONTACT SPRING TENSION, FIG. 16.

Apply an 8 ounce push scale directly above the rear contact spring

and against the front contact spring fibre. It should require from 2 to 3 ounces to cause the front spring to just break contact with the rear spring.

RELAY MOUNTING BRACKET ADJUSTMENT, FIG. 16.

Loosen the relay mounting screws (three) and turn the motor governor until the motor control cam lever is resting on the highest part of the cam. Then adjust the relay so that when the contact lever is against either the left hand stop screw or the stop screw bracket there is from .002" to .004" space between the end of the contact lever and the side of the armature when the armature is against the right hand stop. Tighten the mounting screws.

MOTOR CONTACT SPRINGS ADJUSTMENT, FIG. 16.

With the motor control lever resting against the highest part of the cam raise the end of the contact lever so that the armature may be moved against the left hand stop. Then with the end of the contact lever against the top of the armature, there should be from .010" to .015" space between the motor contacts. If necessary bend the motor contact springs to obtain this space between the contacts, after which the tension should be rechecked and the contacts lined up.

MOTOR CONTROL CAM LEVER SPRING TENSION, FIG. 16.

With the cam lever on the low part of the motor control cam apply an 8 ounce push scale to the top of the lever directly above the left hand stop screw bracket and push down. It should require from 2 to 4 ounces to just start the lever moving.

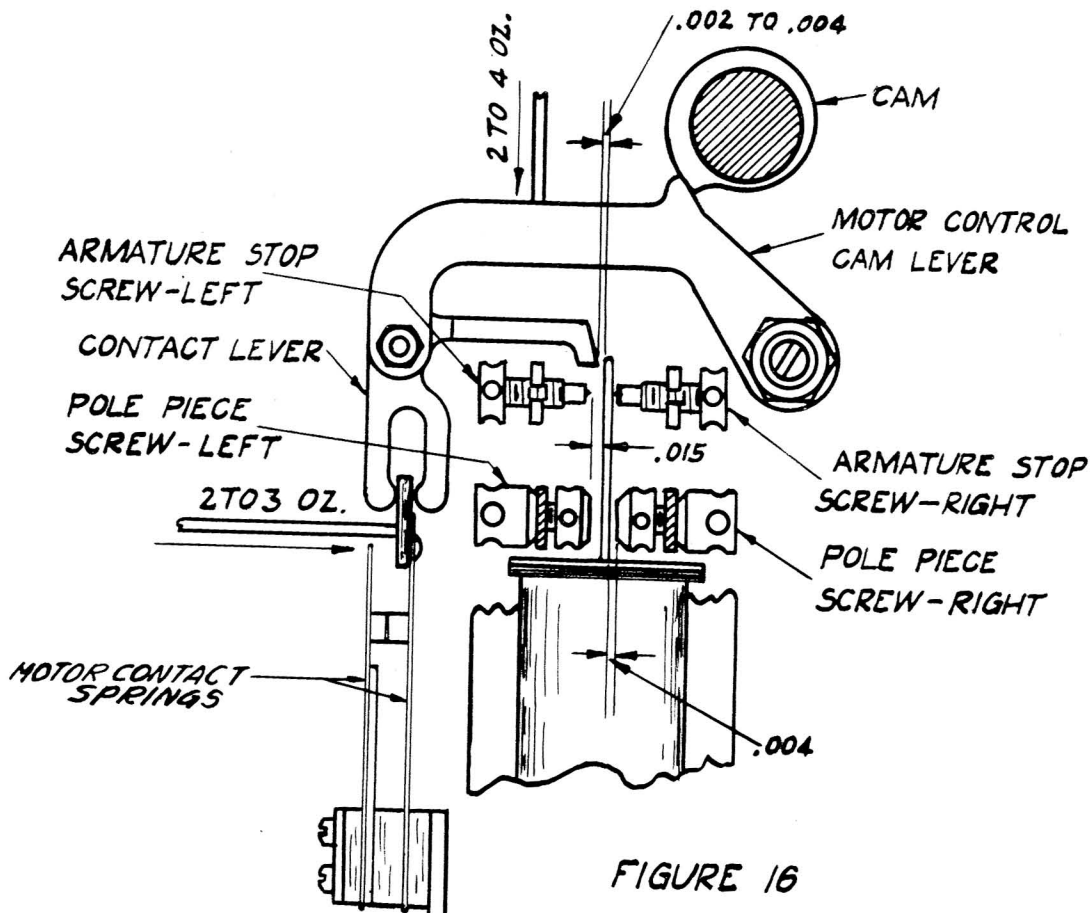

GOVERNOR ADJUSTMENTS.

SPEED ADJUSTING WHEEL, FIG. 17.

To measure the tension of the speed adjusting wheel spring, insert a bank pin in the leather rim (radially) and hook a 32 ounce scale to the pin, making sure that the hook is against the leather rim. Pulling at right angles it should require from 8 to 16 ounces to just start moving the wheel.

ADJUSTING SCREW GUIDE PIN.

The adjusting screw guide pin should be so bent that when the riveted end of the pin is jammed against the adjusting wheel the other end of the pin is held securely in the guide groove by one-half of its thickness.

GOVERNOR BRUSH SPRINGS, FIG. 18.

The required tension to depress the brush spring to its operating length, that is, to within $1/32$ " of the brush holder, shall not be more than 4 ounces and not less than 3 ounces.

The pigtails should be soldered to both the carbon brush and the brass insert of the brush screws.

GOVERNOR BRUSHES POSITION.

Adjust the position of the brush holder bracket so that the brushes project not more than $1/32$ " beyond the holder. Be sure that the brushes ride on the center of the collector rings. Elongated mounting holes are provided in the bracket to make it adjustable.

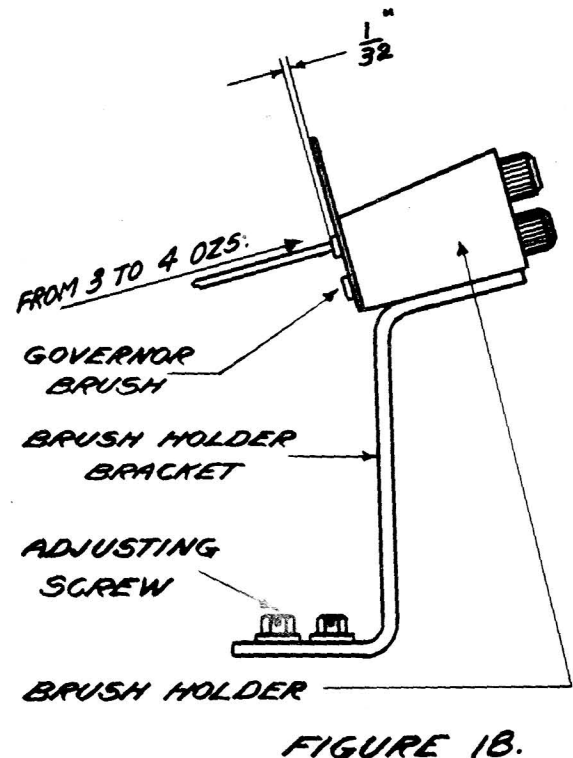
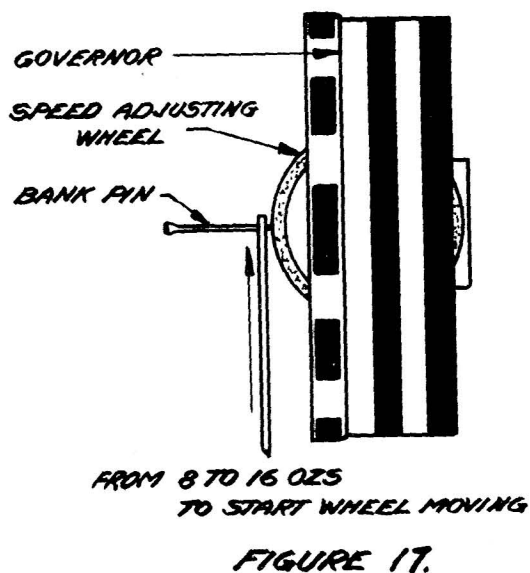

SPEED SETTING.

The tuning fork supplied is used for the purpose of regulating the printer motor speed. The fork is equipped with shutters attached to the ends of the tines. On the rim of the motor governor is attached a speed target of alternate black and white spots.

Tap the fork lightly, just enough to start it vibrating; a sharp blow may cause the shutters to buckle. Hold the fork close to the eye and view the moving spots on the governor through the fork shutters. If the spots appear to be moving in the direction of rotation, the motor speed is too high. The speed is too low if the spots appear to move in a direction opposite to that of rotation. The speed is correct when the spots seem to be stationary.

The motor speed may be increased by pushing against the speed adjusting lever (mounted on the top of the motor next to the governor). This turns the leather speed adjusting wheel in such a direction as to increase the tension of the governor armature spring, thereby speeding up the motor.

The speed is decreased by pressing the speed regulator against the outside surface of the revolving governor. This causes the wheel to be moved in such a way as to decrease the tension of the governor armature.

ORIENTATION.

The orientation scale, mounted directly behind the selector cam friction clutch, is used for the purpose of orientating the printer to the incoming signals.

To take an orientation range a test sentence such as "The quick brown fox, etc." should be transmitted to the printer continually while the range is being taken.

While this sentence is being received shift the orientation scale (loosen the thumb nut) toward "zero" until errors begin to appear in the test sentence. Then move it back slowly until these errors disappear. This position indicates one limit of the orientation range. Note the position on the scale. Repeat the same performance toward the opposite end of the scale to find the other limit.

After the two limits (or extreme positions of perfect printing) have been found the orientation scale should be set midway between these two points.

LINE CURRENT.

About 50 milliamperes are required for the operating coils when they are connected in series and about 100 milliamperes when they are connected in parallel.

OPERATING COIL RESISTANCE.

The operating coils measure 37 ohms each.

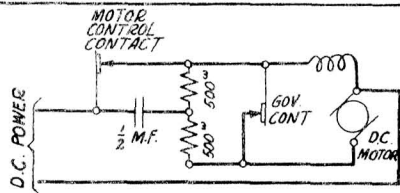

SCHEMATIC DIAGRAM OF
D.C. MOTOR CIRCUIT

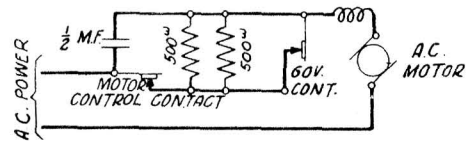

SCHEMATIC DIAGRAM OF
A.C. MOTOR CIRCUIT

- ① TWO WIRES FROM 6 TO 7 INSTEAD OF ONE
- ② CHANGED LINE JACK

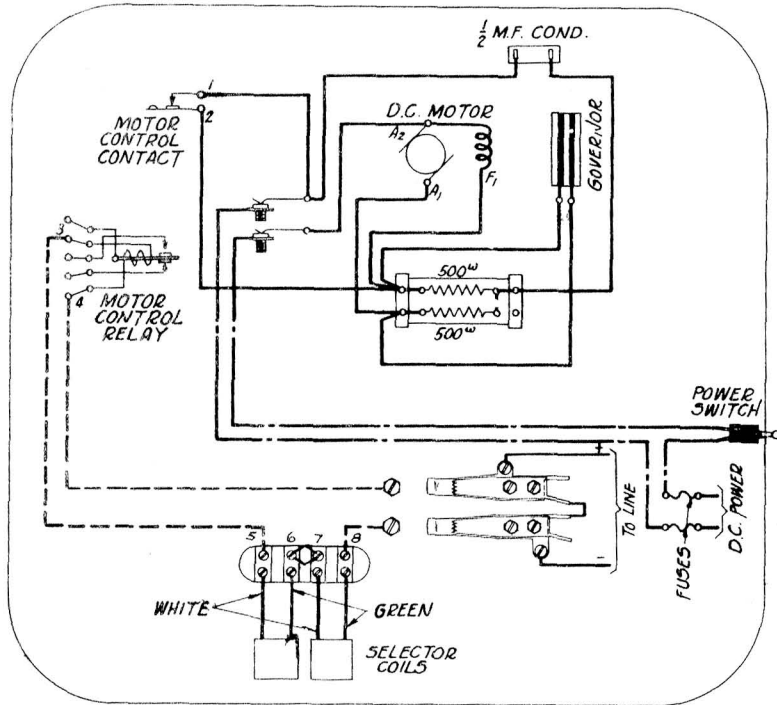

TICKER TELETYPE WITH D.C. MOTOR
(TOP VIEW)

NOTE:
ALL WIRES TO BE "DELTA BESTEN" EXCEPT WIRES FROM MOTOR

--- PRINTER CABLES
--- BASE CABLE

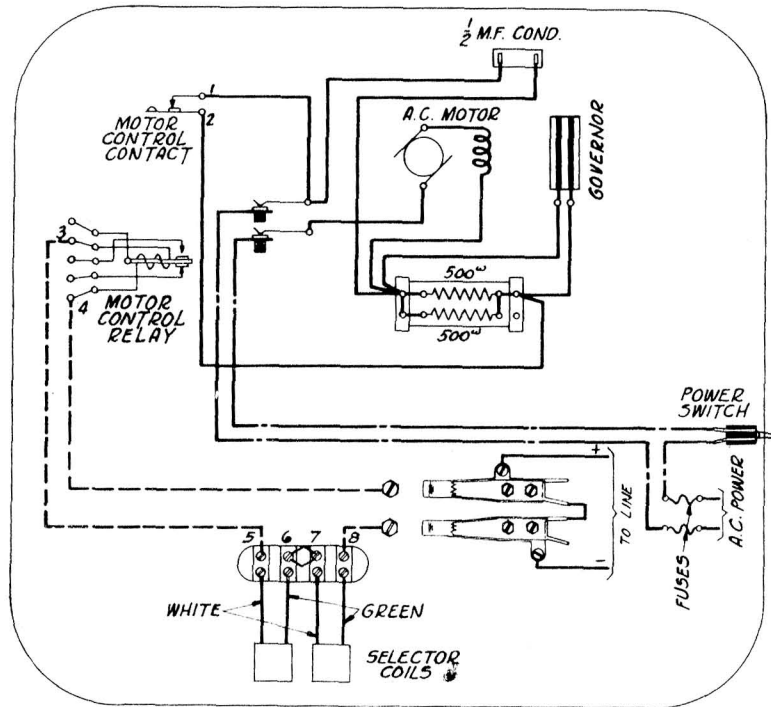

TICKER TELETYPE WITH A.C. MOTOR
(TOP VIEW)

WHEN CONTROL RELAY IS OMITTED SPLICE AND TAPE
WIRE 1 TO 2 AND WIRE 3 TO 4.

TO CONNECT SELECTOR MAGNETS IN MULTIPLE: STRAP 5 TO 7 & 6 TO 8.
TO CONNECT SELECTOR MAGNETS IN SERIES: STRAP 6 TO 7

MORCKUM-KLEINSCHMIDT CORPORATION	
967	
NOV. 1, 1928	
967-A	①
DEC. 4, 1928	
967-B	②
DEC. 10, 1928	

WIRING DIAGRAM
FOR
T.W.T.P. 1, 2 & 3
ARB-1

TICKER
TELETYPE

DRAWN
TRACED E.W.
CHECKED E.S.L.
ENG'R'D. H.L.P.
APPROVED

ADDITION TO BULLETINS

Bulletin 127, Issue 3, Type Bar Tape Printer (Model 14) , Page 36
Bulletin 137, Issue 2, Typewheel Tape Printer (Ticker), Page 29
Bulletin 138, Issue 5, Type Bar Page Printer (Model 15), Page 50
Bulletin 141, Issue 3, Transmitter, Page 18
Bulletin 147, Issue 2, Single Magnet Reperforator, Page 14
Bulletin 159, Issue 2, Typewheel Page Printer (Model 26), Page 36
Bulletin 160, Issue 1, Type Bar Printer (Model 20), Page 38
Bulletin 170, Issue 1, Multiple Transmitter Distributor and Base, Page 9
Bulletin 171, Issue 2, Typing Reperforator, Page 22
Bulletin 175, Issue 1, Single Unit Transmitter and Base, Page 8
Bulletin 176, Issue 1, Translator Unit, Receiving Distributor and Pane, Page 8
Bulletin 178, Issue 1, Reperforator Transmitter Distributor, Page 36
Bulletin 182, Issue 1, Multiplex, Start-Stop Extensor Set, Page 22
Bulletin 183, Issue 1, Portable Signal Distortion Test Set, Page 5
Bulletin 185, Issue 1, Multiple Transmitter Distributors and Base, Page 12
Bulletin 186, Issue 1, Two Channel Start-Stop Transmitter Distributor, Page 20
Bulletin 189, Issue 1, XD79 and XD95 Distributors, Page 15
Bulletin 192, Issue 1, Teletype Automatic Wheatstone Perforator Set, Page 19
Bulletin 193, Issue 1, Reperforator Transmitter Distributor (Model 14), Page 9
Bulletin 197, Issue 1, Multiple Reperforator Set, Page 25

Add the following adjustment immediately preceding the "SPEED
ADJUSTING WHEEL FRICTION WASHER SPRING TENSION ADJUSTMENT":

ADJUSTMENTS FOR ALIGNMENT AND SQUARENESS OF GOVERNOR CONTACTS

All governor contacts can be adjusted for alignment of edges; only those governor shells which provide elongated mounting holes for the fixed contact bracket permit adjustment of the contact for height by positioning the contact bracket.

The governor contacts should be in line and meet squarely so that maximum contact surface is provided. (Check with the retractile spring tension Adjusted so that the contacts just make, or the the limit of the adjusting screw).

- (a) Line up edges of contacts by means of the floating contact hinge mounting screw.
- (b) Adjust contacts for squareness from right to left by positioning the height of the fixed contact bracket using the elongated mounting holes in the governor shell.
- (c) To adjust from front to back, twist the floating contact hinge, applying pressure to the arm near the contact.

NOTE: Check by use of a .002" gauge (smaller if available). Check with gauge between edges of contacts to see that the gauge enters (or does not enter equally on all sides.

* * *

CHANGES IN BULLETINS

- 137, Issue 2, Type Wheel Tape Printer (Ticker), Page 29
- 147, Issue 2, Model 14 and 20 Nontyping Reperforator, Page 14
- 159, Issue 2, Model 26 Type Wheel Page Printer, Page 36
- 170, Issue 1, Single and Multiple Transmitter Distributor and Base, Page 9
- 175, Issue 1, Single Unit Transmitter and Base, Page 8
- 176, Issue 1, Translator Unit, Receiving Distributor and Panel, Page 8
- 183, Issue 1, Portable Signal Distortion Test Set (Code Disc Operated), Page 5

SPEED ADJUSTING WHEEL FRICTION WASHER SPRING TENSION ADJUSTMENT

Change the tension requirement for starting the adjusting wheel moving to read "16 to 24 ozs." instead of "16 to 20 ozs."

Bulletin 137 - Change the requirement to read "16 to 24 ozs." instead of "8 to 12 ozs."

Bulletin 147 - Change the requirement to read "16 to 24 ozs." instead of "8 to 16 ozs."

* * *

CHANGES IN LUBRICATION SPECIFICATIONS
WHICH APPLY TO ALL TELETYPE APPARATUS

The following lubricants have been standardized for use on all types of Teletype apparatus. These lubricants supersede those referred to in preceding Teletype specifications. The lubricants can be ordered from Teletype as follows:

88970	1 Qt. of KS-7470 Oil
88971	1 Gal. of KS-7470 Oil
88973	1 Lb. of KS-7471 Grease
*88975	KS-8319 Grease Gun
97116	4-oz. Tube of KS-7471 Grease

The above grease is recommended instead of oil for lubricating motors equipped with ball bearings. The 88975 grease gun should be used for injecting grease into the bearings of Teletype ball bearing motors. The gun may be used also for applying grease to other parts of the apparatus and no other grease container need be carried. If this grease gun is not available, the oil listed in the foregoing should be substituted for lubricating ball bearing motors.

* Instructions for Filling the Grease Gun

1. Unscrew the lubricant tube from the cap casting of the grease gun.
2. Insert fresh lubricant through the open end of the tube with the fingers. Apply gradually to eliminate air pockets.
3. Tamp the lubricant down solidly in the tube by pounding the closed end solidly against the palm of the hand. Continue to add lubricant until the tube is completely filled and the metal follower rests against the perforated tube cover.
4. Fill the cap casting with lubricant flush to the bottom side of the tube threads.
5. Screw the lubricant tube into the cap casting part way only. Then insert a pencil or rod through the perforated tube cover and exert pressure against the metal follower so as to expel any entrapped air past the tube threads. When lubricant begins to ooze through the threads, tighten the lubricant tube securely in the cap casting.
6. Operate the handle back and forth for several strokes or until lubricant is pumped from the nozzle. The gun is then ready for use. If the lubricant does not flow from the nozzle in a solid stream, it is an indication that all air has not been expelled from the lubricant tube. Invert the gun and pound the cap casting end against the palm of the hand to jar the lubricant into the pump cylinder.

*Instructions for Lubricating Motor Ball Bearings

The motor bearings are packed with grease before the motor leaves the factory and under ordinary operating conditions need no additional lubrication for

approximately two months. At the regular lubricating intervals one or two strokes of the plunger of the gun should apply sufficient grease to each bearing. To lubricate, press the nozzle of the gun against the ball oiler and force the grease into the hole by pushing on the plunger of the gun. Care should be taken that the bearings are not overloaded. Overloading will result in the grease oozing out of the end castings and being forced into the motor or being thrown on other parts of the mechanism. After lubricating, the motor should be run for a few minutes and then any excess grease that has been forced out of the ends of the castings should be wiped off. Each time that the gun is used for lubricating a motor bearing, the plunger should first be depressed slightly to make sure that grease will be delivered.

ADJUSTMENTS OF TICKER SELECTOR MAGNET UNIT
WITH "T" SHAPED ARMATURE

To be used in conjunction with Bulletin 137 -
Description and Adjustments of the
Typewheel Tape Printer (Ticker).

Page 12.

Cancel: SELECTOR ARMATURE PIVOT SCREWS ADJUSTMENT.
SELECTOR ARMATURE POLE PIECES AND BUFFER SCREWS ADJUSTMENT, FIG. 7.

and substitute the following:

SELECTOR ARMATURE PIVOT SCREWS ADJUSTMENT:-Remove permanent magnet and back off armature buffer screws. Adjust the "up" and "down" position of the armature, by means of its pivot screws, so that the top surface of the armature is flush with the top surfaces of the right ends of the pole pieces, and so that the armature is free, without end play. Replace permanent magnet so that the mark "TOP" is uppermost.

PERMANENT MAGNET ADJUSTMENT:-Adjust the position of the permanent magnet so that the ends of the magnet are approximately $\frac{3}{4}$ " from the left ends of the pole pieces (See figure).

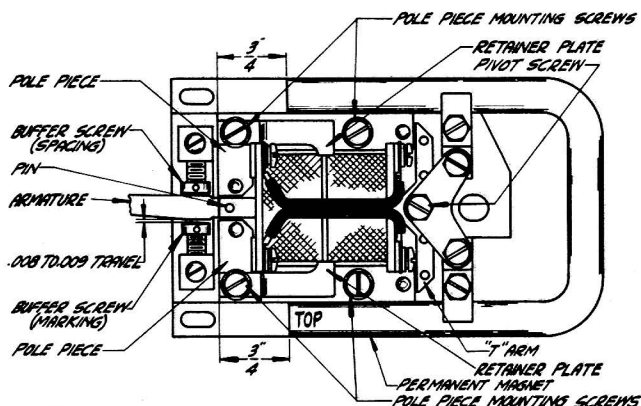

POLE PIECES ADJUSTMENT:-Loosen pole piece mounting screws. Move one pole piece as far toward the buffer screws as possible, holding it against the permanent magnet, and tighten the mounting screws just enough to hold the pole piece in this position. Hold the armature against this pole piece at the left end and adjust the other pole piece so that it just touches the "T" arm of the armature. Make sure that this pole piece is against the permanent magnet and tighten the mounting screws. Now hold the left end of the armature against this pole piece and adjust the other pole piece so that it just touches the "T" arm of the armature. Make sure that this pole piece is against the permanent magnet and tighten the mounting screws.

Note:-When tightening the left hand pole piece mounting screws hold the selector coil retainer plates so that the selector coils are held securely between the retainers.

BUFFER SCREWS ADJUSTMENT:- (A) Insert a .020" gauge between the left end of one pole piece and the armature. Hold the armature against the gauge and adjust the buffer screws so that there is from .004" to .005" space between each buffer screw and the side of the armature. Remove the .020" gauge. (B) Place the selector armature on the spacing side, hook an 8 oz. scale over the pin on the armature and pull at right angles toward the front of the printer. Observe the tension required to pull the armature to the marking side. Now hook the scale over the pin and pull at right angles toward the rear of the printer. Observe the tension required to pull the armature to the spacing side. If the two tensions are not within one ounce of being equal, refine the buffer screws adjustment. This adjustment should be made so that the armature will have from .008" to .009" travel between the buffer

(over)

screws (See figure).

Page 13.

MAGNET BASE POSITION, FIG. 8 - change to read: "from .003" to .005" instead of "from .002" to .004".

Insert after MAGNET BASE POSITION, FIG. 8.

After tightening base mounting screws recheck BUFFER SCREWS ADJUSTMENT, item (B). If it is necessary to change the adjustment of the buffer screws recheck MAGNET BASE POSITION.

ADJUSTMENTS OF FIVE UNIT TICKER SHIFT MECHANISM

To be used in Conjunction with Bulletin #137 -
Description & Adjustments of Typewheel Tape Ptr. (Ticker)

For tickers equipped with the five unit shift mechanism add the following adjustments after flutter cam oiler adjustment on page 23, Bulletin 137.

1-Remove cover guide. Place the code discs in the spacing position. Loosen the shift pawl lever arm mounting screws and the shift bracket mounting stud and screw. Adjust the shift bracket so that there is from .070" to .080" space between the shift pawl lever roller and the lower shift pawl when the roller is against the upper shift pawl (near the upper end). Tighten the shift bracket mounting stud and screw and recheck the above adjustment.

2-Remove both shift pawl springs and check pawls for freeness. Replace springs.

3-Check to see that the shift pawl lever roller turns freely and that the pin is bent so as to be safe from falling out.

4-Check to see that the shift pawl lever is free and has not more than .006" end play.

5-Adjust the shift pawl lever arm so that the pin on the shift pawl lever does not bind in the selector lever when in either the marking or the spacing position and so that the travel of the shift pawl lever roller is centered between the upper and lower shift pawls. Tighten the shift pawl lever arm mounting screws and recheck the above adjustment.

6-Check to see that when the #6 selector lever is in the marking position there is a clearance of from .002" to .006" between the shift pawl lever roller and the lower shift pawl when the play of the shift pawl lever and roller is taken up in a direction to make this clearance a maximum. Make the same check between the shift pawl lever roller and the upper shift pawl with the #6 selector lever in the spacing position. If necessary readjust the shift pawl lever arm or the shift bracket to obtain the above clearances. If it is necessary to readjust either arm or bracket recheck adjustment #5.

7-Check to see that both upper and lower shift pawls are safely on their stop pin rollers and that they clear the front guide disc.

8-Place the code discs in the marking position and #6 selector lever in the spacing position and check to see that there is not more than .015" clearance between the shift pawl lever roller and the lower shift pawl when all the play of the shift pawl lever and roller is taken up in a direction to make this clearance a maximum.

Make the same check between the shift pawl lever roller and the upper shift pawl when #1, #2, #4 and #5 code discs and #6 selector lever are in the marking position and #3 code disc is in the spacing position.

9-Place the code discs in the spacing position and check to see that the center of the shift pawl lever roller is at least .010" below a line connecting the upper ends of the shift pawls.

10-UPPER AND LOWER SHIFT PAWL SPRING TENSION:- With the code discs in the spacing position hook a 32 oz. scale over each pawl at the end of the pawl and pull at right angles to the pawl. It should require from 10 1/2 to 14 ozs. to just start each pawl moving.

11-Replace cover guide.

LUBRICATION:

In addition to the parts listed on page 8, Bulletin 137, the following parts of the new shift mechanism should be lubricated in the same manner:

- | | | | |
|-----|--------------------------|-----|----------------------|
| (1) | Shift pawl lever roller | (3) | Shift pawl lever pin |
| (2) | Shift pawl lever bearing | (4) | Shift pawl bearing |

(over)

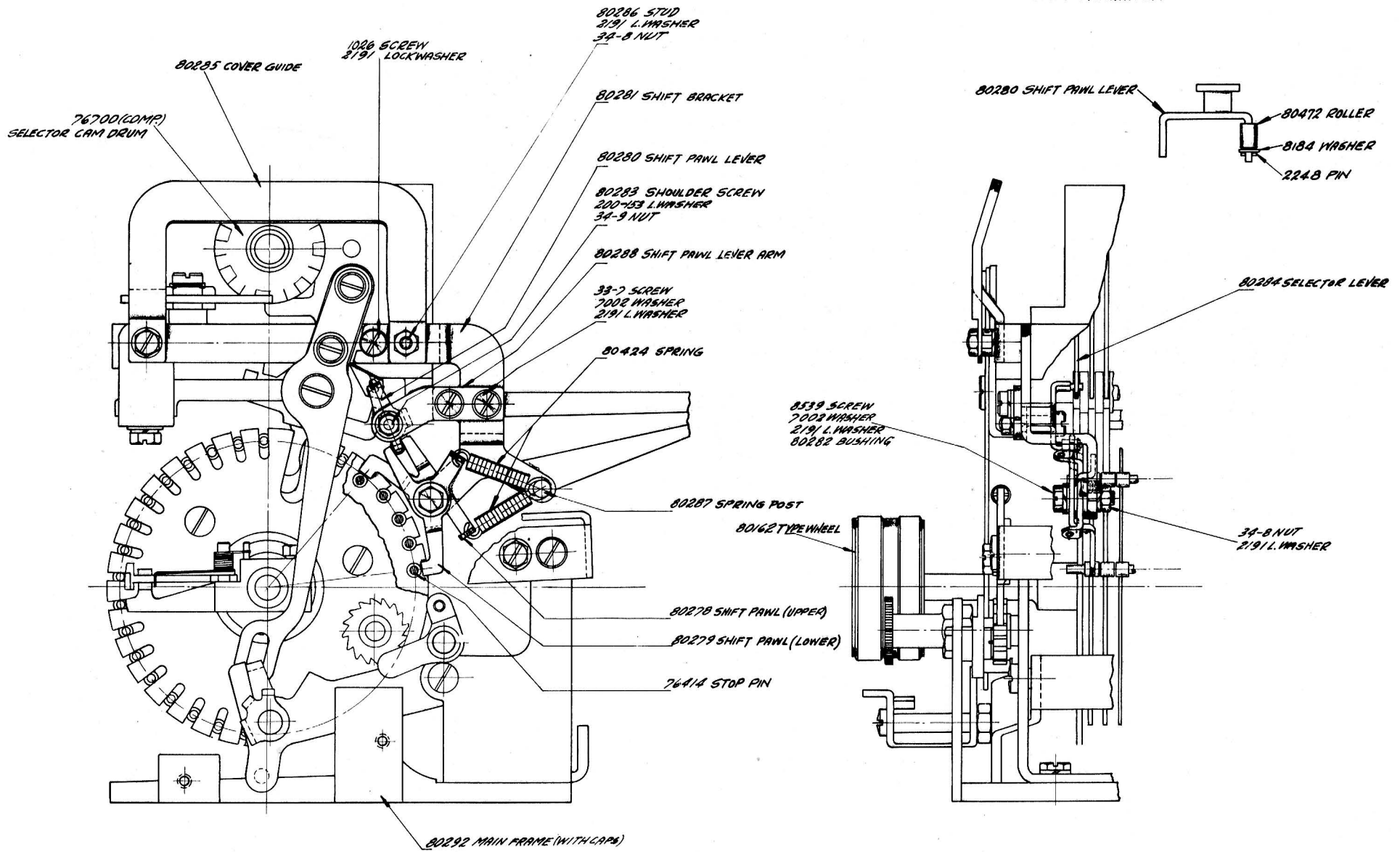

CP-14 USES #80285 POLAR MAGNET (COMP)

PARTS NOT LISTED HERE ARE THE SAME AS SHOWN ON PAGE #1 & 2 BULLETIN 1036

