

412574

Bulletin No. 163  
Issue 1  
April, 1941

FOR INFORMATION OF LABORATORIES ONLY

NOT APPROVED

# TELETYPE

FOR BELL SYSTEM USE  
PRINTING TELEGRAPH SYSTEMS

DESCRIPTION AND ADJUSTMENTS  
TYPE BAR TAPE PRINTER  
(MULTIPLEX SEVEN UNIT)

*not used  
in Bell  
System*

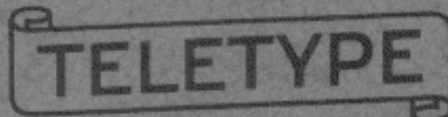

CORPORATION

SUBSIDIARY OF

*Western Electric Company*

CHICAGO, U.S.A.

Bulletin No. 163  
Issue 1  
April, 1941

# TELETYPE

PRINTING TELEGRAPH SYSTEMS

DESCRIPTION AND ADJUSTMENTS  
TYPE BAR TAPE PRINTER  
(MULTIPLEX SEVEN UNIT)



CORPORATION

SUBSIDIARY OF

*Western Electric Company*

CHICAGO, U.S.A.

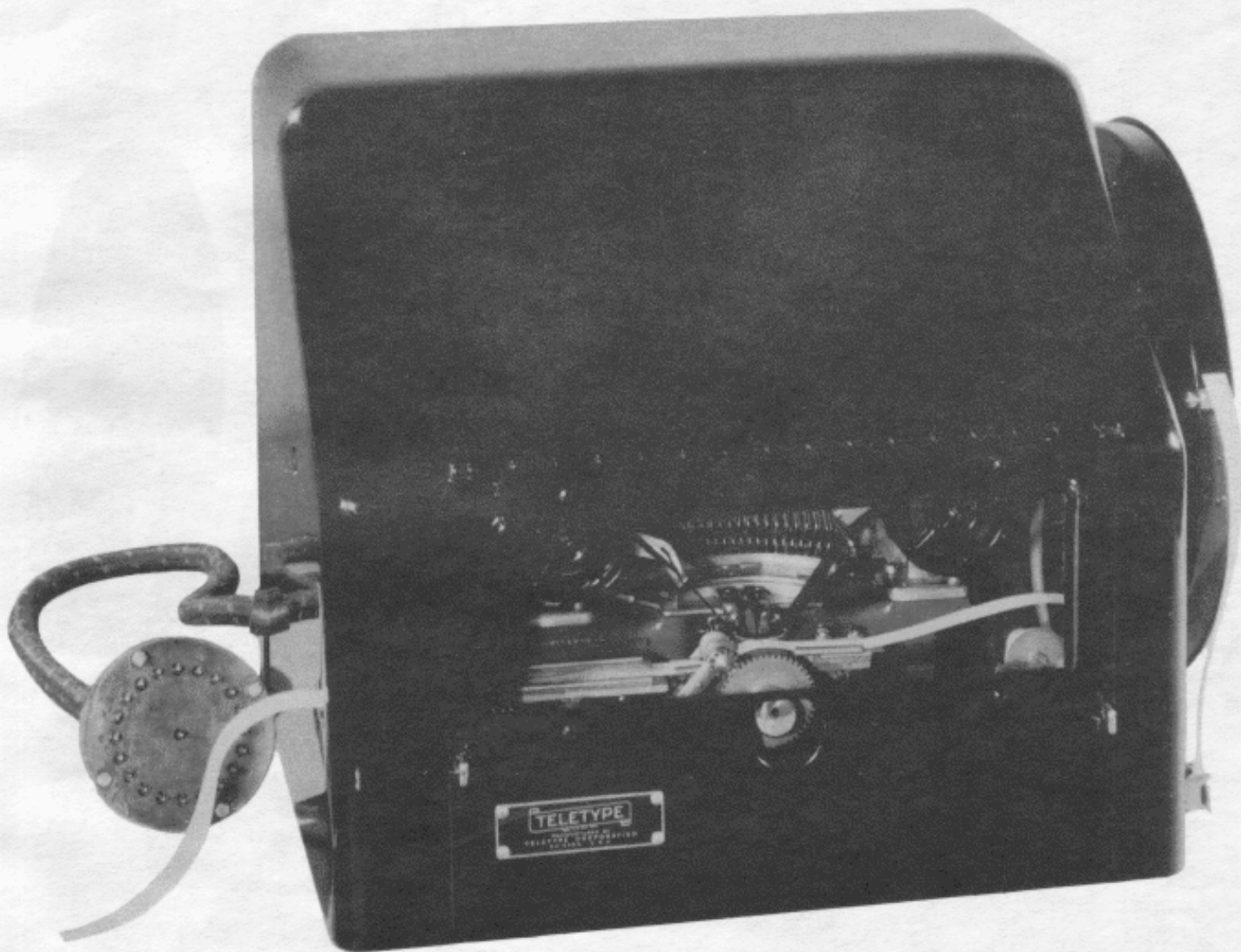

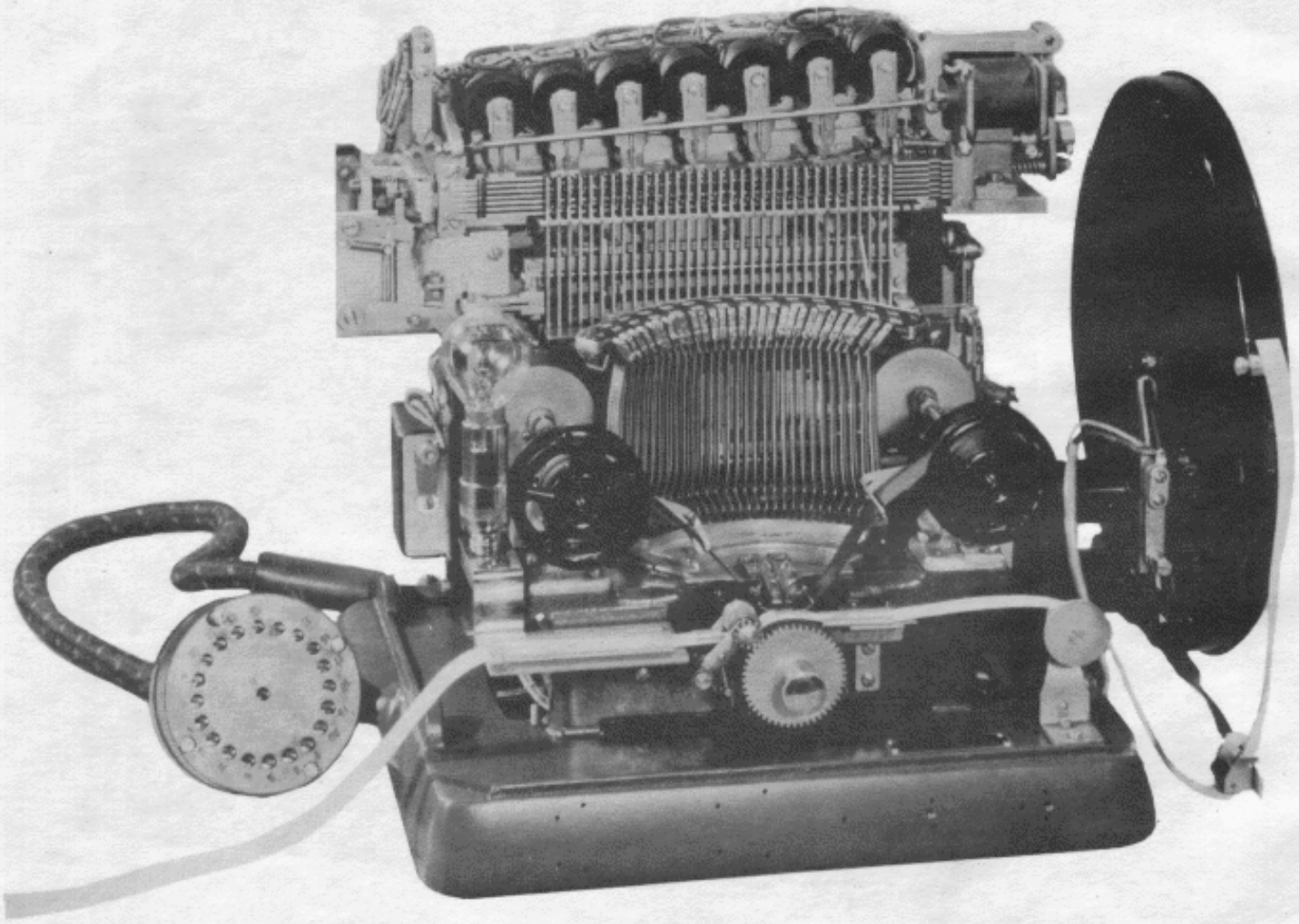

C O N T E N T S

	<u>Page</u>
<u>ADJUSTMENTS</u>	
Beam Reset Arm Adjustment . . . . .	15
Beam Reset Arm Spring Tension . . . . .	14
Bell Adjusting Lever Position . . . . .	17
Bell Crank Eccentric Adjustment . . . . .	14
Bell Hammer Bracket Adjustment . . . . .	17
Bell Hammer Spring Tension . . . . .	16
Blocking Lever Bracket Adjustment . . . . .	13
Blocking Lever Spring Tension . . . . .	14
Carriage Jockey Arm Spring Tension . . . . .	17
Carriage Return Spring Tension . . . . .	7
Contact Break Arm Spring Tension . . . . .	21
Contact Lock Operating Screw Adjustment . . . . .	12
Cutout Shaft Fingers Adjustment . . . . .	9
Cutout Shaft Lever Position . . . . .	9
Cutout Shaft Pivot Screw Adjustment . . . . .	8
Eighth Pulse Armature Arm Left Stop Adjustment . . . . .	6
Eighth Pulse Armature Arm Right Stop Adjustment . . . . .	6
Eighth Pulse Contact Bracket Adjustment . . . . .	8
Eighth Pulse Contact Screw Adjustment . . . . .	8
Eighth Pulse Contact Spring Tension . . . . .	8
Eighth Pulse Cutout Shaft Spring Tension . . . . .	9
Eighth Pulse Relay and Printing Relay Adjustments . . . . .	18
Feed Pawl Reverse Rod Detent Spring Adjustment . . . . .	18
Feed Pawl Reverse Rod Detent Spring Tension . . . . .	19
Figures Adjusting Screw Adjustment. . . . .	16
Letters Adjusting Screw Adjustment . . . . .	16

ADJUSTMENTS (Continued)

Page

Lock Arm Spring Tension . . . . .	9
Lock Arm Trip Spring Tension . . . . .	9
Lock Restoring Arm Stop Screw Adjustment . . . . .	12
Misselection Gong Adjustment . . . . .	17
Misselection Gong Hammer Spring Tension . . . . .	18
Misselection Mechanism Mounting Plate Adjustment . . . . .	13
Misselection Pull Bar Spring Adjustment . . . . .	22
Platen Carriage Tracks Adjustment . . . . .	16
Platen Shaft Retainer . . . . .	14
Printing Bail Adjustment . . . . .	11
Printing Bail Extension Blade Adjustment . . . . .	12
Printing Bail Frame Adjustment . . . . .	10
Printing Bail Roller Arms Adjustment . . . . .	11
Printing Bail Spring Tension Adjustment . . . . .	21
Printing Break Contact Screw Adjustment . . . . .	21
Printing Break Contact Spring Tension . . . . .	21
Printing Contact Lock Bracket Adjustment . . . . .	9
Printing Contact Screw Adjustment . . . . .	9
Printing Contact Spring Tension . . . . .	10
Printing Relay Adjustments . . . . .	18
Printing Solenoid Plunger Lower Stop Nut Adjustment . . . . .	10
Printing Solenoid Plunger Upper Stop Nut Adjustment . . . . .	11
Pull Bar Comb Adjustment . . . . .	11
Pull Bar Retaining Bar Adjustment . . . . .	11
Pull Bar Spring Tension . . . . .	6
Ribbon Feed Operating Lever Adjustment . . . . .	19
Ribbon Feed Operating Lever Spring Tension . . . . .	18
Ribbon Feed Pawl and Retaining Pawl Spring Tension . . . . .	20

ADJUSTMENTS (Continued)

Page

Ribbon Feed Reversing Arm Adjustment . . . . .	19
Ribbon Feed Stop Screw Adjustment . . . . .	20
Ribbon Feed Unit Operating Arm Adjustment . . . . .	18
Ribbon Reverse Arms Adjustment . . . . .	19
Ribbon Reverse Shaft Detent Collar Adjustment . . . . .	20
Ribbon Reverse Shaft Detent Spring Tension . . . . .	20
Ribbon Spool Head Adjustment . . . . .	20
Ribbon Spool Shaft Collar Adjustments . . . . .	20
Selector Armature Bracket Adjustment . . . . .	8
Selector Armature Spring Tension . . . . .	8
Selector Armature Stop Nut Adjustment . . . . .	7
Selector Armature Travel . . . . .	7
Selector Bar Detent Spring Adjustment . . . . .	5
Selector Bar Detent Spring Tension . . . . .	6
Selector Bar Pawl and Latch Spring Tension . . . . .	5
Selector Bar Pawl Latch Trip Strip Adjustment . . . . .	7
Selector Bar Return Lever Adjusting Screw Adjustment . . . . .	10
Selector Bar Return Lever Spring Adjustment . . . . .	10
Selector Carriage Push Rod Nut Adjustment . . . . .	6
Selector Carriage Push Rod Spring Tension . . . . .	7
Selector Magnets Base Adjustment . . . . .	7
Shift Cross Arm Adjustment . . . . .	17
Space Operating Arm Adjustment . . . . .	16
Spacer Ratchet Shaft Collar Adjustment . . . . .	15
Spacing Beam Left Stop Screw Adjustment . . . . .	15
Spacing Beam Right Stop Screw Adjustment . . . . .	15
Spacing Detent Spring Tension . . . . .	14
Tape Lever Spring Tension . . . . .	22

ADJUSTMENTS (Continued)

Page

Tape-Out Contact Adjustment . . . . .	21
Unlocking Bail Bearing Plate Adjustment . . . . .	12
Unlocking Bail Stop Screw Adjustment . . . . .	13
Universal Bar Stop Screw . . . . .	14
Universal Bar Support Spring Tension . . . . .	14
Word-Space Link Adjusting Plate Adjustment . . . . .	15
Word-Space Vertical Bar Upstop Adjustment . . . . .	11

DESCRIPTION

Figures Shift and Letters Shift . . . . .	3
General . . . . .	1
Misselection Indicator Mechanism . . . . .	2
Printing . . . . .	2
Ribbon Feeding . . . . .	3
Ribbon Reverse . . . . .	4
Selector Mechanism . . . . .	1
Signal Bell . . . . .	3
Signaling Code . . . . .	1
Spacing . . . . .	3
Tape-Out Buzzer . . . . .	4
Tie-Up Lamp . . . . .	4

LUBRICATION SPECIFICATION

23



## DESCRIPTION OF THE MULTIPLEX SEVEN UNIT TAPE PRINTER

### General

The Seven Unit Multiplex Tape Printer is a magnet operated unit for receiving messages. It is arranged to print a misselection indicating symbol and produce an audible signal when more or less than the required number of selecting impulses are received.

### Signaling Code

The seven unit signaling code used to select the various characters and functions is arranged especially for use in connection with the misselection indicating mechanism. Each character or function employs three marking impulses and four spacing impulses as shown in Figure 1. Impulses which operate selector magnets are known as marking and those which do not are known as spacing.

### Selector Mechanism

The selector mechanism located at the top of the unit consists essentially of seven selector magnets, a selector carriage, seven selector bars, an eighth pulse magnet, and an eighth pulse relay. The selector carriage assembly, located immediately in front of the lower end of the selector magnet armatures, consists of a selector carriage, seven selector bar pawls, and seven selector bar pawl latches (Figure 2).

When a selector magnet is energized by a marking impulse, its armature moves a selector bar pawl (Figure 2) into a notch of an adjacent selector bar. The associated selector bar pawl latch engages the selector bar pawl and holds it in its operated position. After the three marking impulses of any code combination have been distributed to the selector magnets an eighth impulse from the distributor operates the eighth pulse relay located in back of the eighth pulse magnet. The eighth pulse relay remains energized through a locking circuit and the contacts of the relay close a local circuit to energize the eighth pulse magnet which when operated moves the selector bar carriage to the left and carries with it the selector bars that are engaged by the operated selector bar pawls. As the selector carriage reaches the end of its travel, the selector bar detent springs drop into the right-hand notches of the operated selector bars and hold them in the operated position. Simultaneously, the trip latches cause the selector bar pawl latches to release the operated selector bar pawls, and the eighth pulse cutout lever, (Figure 3) located near the left end of the selector bar carriage, opens the eighth pulse contact thus breaking the locking circuit to the eighth pulse relay and allowing the selector carriage to return by spring to its unoperated position.

To suppress operation of the eighth pulse relay when no selection is received, a cutout shaft with seven fingers and a cutout shaft lever, located in front of the selector magnets, is provided. When the eighth pulse cutout lever is operated by the selector carriage, the cutout shaft lever engages the cutout lever and holds the eighth pulse contact open. The eighth pulse contact remains open until a selector magnet armature is operated. As the selector magnet armature responds to the code impulse, its lower extension strikes its associated finger on the cutout shaft and causes the cutout shaft lever to release the eighth pulse cutout lever and permit the eighth pulse contacts to close.

## Printing

With three of the selector bars positioned to the left in accordance with the code shown in Figure 1, notches in the selector bars will be aligned for the selection of a pull bar.

When the selector carriage is moved to its operated position, (left) it rotates the selector bar return lever (located at the left-hand end of the selector bars) to the left. The return lever is latched in its operated position by the lock arm (Figure 3). An extension of the return lever permits the printing contacts to close completing the circuit to the printing relay (mounted on the rear of the right frame casting) through the printing break contacts located in back of the selector magnets (Figure 4). When the printing relay armature pulls up, its contacts close the relay locking circuit and the circuit to the printing solenoid, through the printing break contacts.

As the printing solenoid plunger is drawn downward, it rotates the printing bail through a linkage and moves the printing bail roller upward, allowing the pull bars to move toward the selector bars (Figure 4).

The selected pull bar will move farther than the others into the notches of the code bars and into the path of the printing bail. As the printing bail continues on its upward stroke, the selected pull bar will also be moved upward. The lower end of the pull bar being linked to a type bar, through a horizontal lever, the type bar will be rotated so that its pallet moves against the platen (Figure 4).

When the printing bail completes its stroke, the printing break contacts are opened by the contact break arm and the circuits to the printing relay and solenoid are opened.

When the printing solenoid is de-energized, the printing shaft spring, attached to the ribbon feed unit operating arm, returns the printing bail to its unoperated position (Figure 5). As the printing bail is returning to its unoperated position the printing bail roller moves the pull bars away from the selector bars and the contact lock operating screw mounted on the left-hand end of the printing bail, moves the lock restoring arm down (Figure 3). The lock arm trip latch connected to the lock restoring arm, unlatches the lock arm permitting the selector bar return lever to restore the selector bars to their unoperated position and open the printing contacts.

## Misselection Indicator Mechanism

The printing of an error (misselection) symbol in the event that more or less than three impulses are received, is accomplished by an unblocking bail which is mounted to the rear of the pull bars so that it will be rotated when any pull bar is selected. A notch is cut into the unblocking bail opposite the misselection pull bar so that any movement of this pull bar will not affect the unblocking bail. A blocking lever, which is linked to the unblocking bail, is also located to the rear of the misselection pull bar. When the unblocking bail is rotated, the blocking lever is moved out of the path of the misselection pull bar and this pull bar will in turn move to the rear out of the path of the printing bail extension. The selector bars are cut to provide a path for the misselection pull bar regardless of the selection received, (Figure 4).

When more or less than three selector bars are operated, the unblocking bail and blocking lever will not be rotated and the misselection pull bar will remain in the path of

the printing bail extension. When the misselection pull bar is moved upward by the printing bail, the error symbol will be printed and the lower end of the pull bar will engage a gong hammer arm to provide a gong stroke with each operation (Figure 7).

### Spacing

When any character is printed, the type bar depresses the universal bar located immediately beneath the type bar segment (Figure 4). This permits the beam reset arm to rotate the spacing beam against the right spacing beam stop screw and in doing so the spacing pawl advances one tooth on the spacing ratchet (Figure 6). As the printing shaft spring returns the printing bail to its unoperated position, the space operating arm (Figure 4) which is clamped to the printing shaft, moves the spacing beam against its left stop screw by means of the space connecting rod, and the spacing pawl rotates the spacing ratchet, advancing the platen one character space (Figure 6).

To space the platen without printing, the space pull bar (which is the extreme right-hand pull bar) is selected. The lower end of this pull bar engages an intermediate bar and the rear extension of the intermediate bar depresses the word-space link which operates the beam reset arm and spacing beam, advancing the spacing pawl one tooth on the spacing ratchet (Figure 6). The actual spacing of the platen is then accomplished as described in the preceding paragraph.

### Figures Shift and Letters Shift

The lower character on most type pallets is a letter and the upper character is a figure or punctuation mark. The platen assembly is arranged so that the position of the platen can be shifted to line up with either the upper or lower case type pallets.

When the platen is in the "letters" position and the "figures" pull bar is selected, the lower end of the pull bar engages the shift cross arm roller and cams the entire platen assembly toward the front of the printer (Figure 7). The carriage jockey arm, operating against the shift cross arm roller, detents the platen assembly in the figures position.

The "letters" shift operation is similar in action to the "figures" shift operation except that the "letters" pull bar is selected. When the "letters" pull bar is raised, it shifts the platen to the rear in the same manner that the "figures" pull bar shifted it forward.

### Signal Bell

While the platen is being moved to the shift position, the bell adjusting lever on the shift cross arm engages the hooked extension of the "J" pull bar and moves it forward, disengaging it from its horizontal bar and engaging it with the rear of the bell hammer arm. Thus, when the bell combination is received ("J" combination, with the platen in the figures position) the bell pull bar rotates the bell hammer arm on its pivot causing it to strike the bell (Figure 7).

### Ribbon Feeding

The ribbon feed mechanism is used to move the typing ribbon. It is operated by the ribbon feed unit operating arm attached to the printing shaft (Figure 5).

The ribbon feed unit operating arm imparts a vertical motion to the ribbon feed pawl through the medium of the ribbon feed unit connecting link, ribbon feed operating lever, and ribbon feed shaft. The vertical motion of the ribbon feed pawl moves the ribbon feed ratchet forward on the downward stroke of the ribbon feed unit connecting link. The retaining pawl holds the ribbon feed ratchet while the ribbon feed pawl moves into engagement with another tooth on the upward stroke of the ribbon feed unit connecting link.

#### Ribbon Reverse

Assuming that the ribbon is being wound on the left-hand spool and is almost unwound from the right-hand spool, an eyelet, fastened to the ribbon a short distance from the end, engages the right-hand ribbon reverse arm and the feeding of the ribbon pulls the ribbon reverse arm downward rotating its shaft and shifting the connecting rod and ribbon reverse pawl to left. The next operation of the printing solenoid will cause the left end of the ribbon feed reversing arm to move downward (Figure 5) bringing the ribbon reverse pawl into contact with the left lug of the reverse rod arm, moving it and the feed pawl reverse rod to the right where it will be held by the reverse rod detent spring. In moving the feed pawl reverse rod to the right, the left-hand ribbon feed pawl and retaining pawl were disengaged from the left-hand ribbon feed ratchet and the right-hand ribbon feed pawl and retaining pawl are engaged with the right-hand ribbon feed ratchet.

#### Tie-up Lamp

The tie-up lamp, located on the left side of the printer, is provided to indicate that signals are being received. If the printer is not operating and the tie-up lamp is flickering it is an indication that the printer is not functioning as it should.

#### Tape-out Buzzer

The tape-out buzzer is provided to warn the attendant that the supply of tape is almost exhausted. The tape lever, which is pivoted on the tape reel bracket is held against the periphery of the roll of tape by its spring. When the supply is depleted, the insulator attached to the tape lever engages the contact spring, closing the circuit to the tape-out buzzer.

## ADJUSTMENTS OF THE SEVEN UNIT MULTIPLEX TAPE PRINTER

The following adjustments are arranged in a sequence that would be followed if a complete readjustment of the printer were undertaken. This fact should be kept in mind when a single adjustment is to be made.

When the text of any adjustment in this bulletin specifies the setting up of a certain character or function, the following method should be used:

Move all the selector bars to their right-hand position and move the selector bar return lever to its left-hand (latched) position. With a pencil point, or other pointed object, move to the left-hand position those selector bars which correspond with the marking impulses of the code combination to be set up. See Figure 1 for chart of code combinations. Then proceed in accordance with instructions outlined in that particular adjustment specification.

The spring tension values given in this bulletin were derived from measurements made with Teletype spring scales. These scales are calibrated for use in a vertical "pull" position. When used in any other position, the reading is an indicated value. Therefore, in order to obtain the proper spring value readings, the spring scales which are included in the Teletype catalog tool list should be used.

### Selector Bar Pawl and Latch Spring Tension (Figure 8)

To check the selector bar pawl and latch spring tension, it is necessary to lift out the selector carriage. To do this, unhook the cutout shaft spring, (Figure 16-A) remove the three selector magnet base mounting screws and remove the selector magnet base (Figure 13). Remove the left selector carriage retaining plate and loosen the right retaining plate screw (Figure 9). Unhook the selector carriage return spring from the carriage and lift out the carriage (Figure 8).

To measure the selector bar pawl spring tension, hook an 8 oz. scale over the rear edge of the pawl, close to the selector bar pawl latch (Figure 8-A). Hold off the selector bar pawl latch and pull toward the front of the carriage. It should require  $3/4$  to 1 oz. to start the pawl moving.

To measure the seventh selector bar pawl latch spring tension, turn the selector carriage upside down and hook an 8 oz. scale over the front notch in the seventh selector bar pawl latch (Figure 8-B). Pull parallel to the carriage, at the same time holding off the selector bar pawl. It should require  $1/2$  to  $3/4$  oz. to start the latch moving.

Replace the selector carriage, retaining plate, selector magnet base, and cut-out shaft and spring. Make certain that the carriage is free from binds before installing the carriage return spring.

### Selector Bar Detent Spring Adjustment (Figure 9)

The selector bar detent spring should be positioned so that the fingers of the spring enter the left and right-hand notches of the selector bars to an equal depth when the selector bars are shifted from side to side.

---

Note: After making a single adjustment, check related adjustments

To adjust, loosen the selector bar detent spring mounting screws and position the detent spring. Tighten the mounting screws.

#### Selector Bar Detent Spring Tension (Figure 9)

With all the selector bars to the left, hook an 8 oz. scale in the extreme right-hand notch in each selector bar and pull to the right in line with the bar. It should require from 3 to 4 ozs. to move each selector bar from its left-hand position to its right-hand position. Bend the detent spring fingers to obtain the correct pressure. Make certain that the detent spring fingers hold the selector bars firmly against their stop plates in both right and left positions.

#### Pull Bar Spring Tension (Figure 23)

To measure the tension of the pull bar springs, place the printer on its rear side. Hook an 8 oz. scale over the end of the pull bar and pull vertically upward. It should require  $3/4$  to  $1-3/4$  ozs. to start each pull bar moving except the misselection pull bar. It should require 2 to  $2-1/2$  ozs. to start the misselection pull bar moving.

Place the printer in its normal upright position.

#### Eighth Pulse Armature Arm Left Stop Adjustment (Figure 10)

When the eighth pulse magnet is energized, there should be .002" to .005" clearance between the eighth pulse armature and the eighth pulse magnet poles.

To adjust, connect the printer to a source of power and depress the armature of eighth pulse relay which is located in back of the eighth pulse magnet. Position the eighth pulse armature arm left stop to obtain the required clearance.

#### Selector Carriage Push Rod Nut Adjustment (Figure 10)

With all of the selector bar pawls engaged with their selector bars and the eighth pulse armature arm held against its left-hand stop, there should be some clearance, not over .004", between the selector carriage push rod nut and the push rod spring collar. (See Figure 11 for location of parts.)

To adjust, latch all of the selector bar pawls in the operated position by inserting a turn of small gauge magnet wire between each selector armature and its stop nut (Figure 13). Move the eighth pulse armature arm against its left stop and adjust for the proper clearance by means of the selector carriage push rod nut.

Recheck to make sure of clearance between the selector carriage push rod nut and the push rod spring collar after the lock nut is tightened.

#### Eighth Pulse Armature Arm Right Stop Adjustment (Figure 11)

With all of the selector bar pawls in the operated position (forward) and the selector bars in the right-hand position, there should be a clearance of .030" to .060" between the left-hand extremity of each selector bar pawl and the left side of the notch in its associated selector bar.

Adjust by means of the eighth pulse armature arm right stop (Figure 10).

---

Note: After making a single adjustment, check related adjustments.

### Selector Bar Pawl Latch Trip Strip Adjustment (Figure 11)

With all of the selector bar pawls in the operated position (forward) and the selector carriage to the right, there should be some clearance, not over .004", between the side of each trip latch and its associated selector bar pawl latch.

To adjust, loosen the trip strip mounting screws and slide the trip strip to the position most favorable to all seven selector bar pawl latches. Refine the adjustment by bending the individual trip latches.

### Carriage Return Spring Tension (Figure 12)

Apply the push end of an 8 oz. scale to the end of the selector carriage push rod and push toward the left. It should require 3 to 4 ozs. to start the push rod moving.

### Selector Carriage Push Rod Spring Tension (Figure 12)

With the selector bar return lever held in its right-hand position, apply the push end of a 12 lb. scale to the lower end of the eighth pulse armature arm and push toward the left. It should require 5 to 7 lbs. to start compressing the selector carriage push rod spring. (See Figure 18 for location of parts.)

### Selector Magnets Base Adjustment (Figure 13)

The selector magnet base should be positioned so that the ball points on the lower end of the selector armatures are in line with their associated selector bar pawls.

To adjust, loosen the three selector magnet base mounting screws and position the base by utilizing its slotted mounting holes. Tighten the mounting screws.

### Selector Armature Travel (Figure 14)

With any selector armature against the selector magnet core, the selector bar pawl should overtravel the selector bar pawl latch .002" to .004".

**CAUTION:** If it is found necessary to adjust the armatures, remove the eighth pulse cutout shaft assembly to avoid bending the cutout shaft fingers.

To increase the travel of the pawl, use RCAC armature bender #2200, or insert the end of a small screw driver into the hole in the armature and rotate the handle upward through an arc toward the rear of the printer. To reduce the travel, apply pressure to the end of the armature toward the rear of the printer.

### Selector Armature Stop Nut Adjustment (Figure 13)

With any selector armature resting against the selector armature stop nut and the selector bar pawl in its unoperated position, there should be .004" to .008" clearance between the ball point on the armature and the associated selector bar pawl.

Adjust by means of the selector armature stop nuts.

Note: After making a single adjustment, check related adjustments.

### Selector Armature Spring Tension (Figure 13)

Apply the push end of an 8 oz. scale to the selector armature directly below the selector armature stop nut and push toward the magnet. It should require 1/2 to 1 oz. to start the armature moving.

### Selector Armature Bracket Adjustment (Figure 15)

With all the selector bar pawls engaged with their respective selector bars, and the eighth pulse armature arm held against its left stop, the clearance between the side of each selector armature and its respective selector bar pawl, should be approximately equal to the clearance between the selector bar pawl latches and the selector armatures when the selector carriage is in the unoperated position and the selector bar pawls are in their unoperated position.

To adjust, loosen the selector armature bracket mounting screws and position the bracket by utilizing the clearance in the screw holes. Tighten the mounting screws. (See Figure 13 for location of parts.)

### Eighth Pulse Contact Bracket Adjustment

There should be some clearance, not over .015" between the eighth pulse cutout lever and the selector carriage when the play in the cutout lever bearing is taken up in a direction to make this clearance a minimum. The cutout shaft lever should also clear the selector carriage by at least .004" at the closest point.

To adjust, loosen the screw and nut which mount the bracket to the selector magnet base and utilize the slots in the bracket to obtain the desired clearance. Hold the stud with a screw driver when loosening the nut to avoid disturbing the adjustment of the selector armature bracket. (See Figures 13 and 16 for location of parts.)

### Eighth Pulse Contact Screw Adjustment

This adjustment must be made with the printer connected to a power source. With the printer connected to a power source, advance the eighth pulse contact screw (Figure 16-A) until the contacts just close, energizing the eighth pulse magnet. Then back off the contact screw until the contacts just break. Back off the contact screw one-quarter turn additional. Lock the contact screw in place with its lock nut.

### Eighth Pulse Contact Spring Tension (Figure 17)

Hook an 8 oz. scale over the eighth pulse contact spring just below the contact point and pull at right angles to the contact spring. It should require 1-1/2 to 2 oz. to separate the contacts.

### Cutout Shaft Pivot Screw Adjustment (Figure 16-A)

The cutout shaft should be free on its pivots with no perceptible end play. It is necessary to remove the cutout shaft spring in order to check this adjustment.

Adjust by means of the cutout shaft pivot screw. Lock the pivot screw by means of its lock nut. Recheck the adjustment after tightening the lock nut. Replace the cutout shaft spring.

Note: After making a single adjustment, check related adjustments.



### Cutout Shaft Fingers Adjustment (Figure 13)

The cutout shaft fingers should line up with the buttons on their respective armatures and there should be some clearance, not over .004", between the ends of the fingers and the buttons when the selector magnet armatures are resting against their stop nuts. Make certain that the cutout shaft lever does not interfere with the cutout lever when checking this adjustment. (Figure 16-A).

Adjust the cutout shaft fingers by bending.

### Eighth Pulse Cutout Shaft Spring Tension (Figure 16-A)

With the eighth pulse cutout shaft lever in its unlatched position, it should require a pull of 1/2 to 1-1/2 ozs. to move the cutout shaft fingers away from the armature buttons. To measure, place the printer on its rear side and hook an 8 oz. scale over the cutout shaft spring post at the bend and pull vertically upward.

### Cutout Shaft Lever Position (Figure 16)

When the eighth pulse armature arm is held tightly against its left stop, there should be .002" to .004" clearance between the extreme right edge of the eighth pulse cutout lever and the left edge of the cutout shaft lever (Figure 16-A). Also, when any selector armature is held against its core, the cutout shaft lever should overtravel the latching surface of the cutout lever .002" to .004" (Figure 16-B).

To adjust, loosen the cutout shaft lever clamping screw and position the lever to meet the requirements. Tighten the clamping screw.

### Printing Contact Lock Bracket Adjustment (Figure 18)

With all the selector bars to the left, and the selector bar return lever held in its operated position by the lock arm, there should be a clearance of .010" to .020" between the return lever and the ends of the selector bars.

To adjust, loosen the two printing contact lock bracket mounting screws and position the bracket. Tighten the mounting screws.

### Lock Arm Spring Tension (Figure 19)

With the eighth pulse armature arm held against its left stop, apply the push end of an 8 oz. scale to the right-hand end of the lock arm and push vertically downward. It should require 1-1/2 to 2 ozs. to start the lock arm moving.

### Lock Arm Trip Spring Tension (Figure 19)

Hold the lock restoring arm against its stop screw. Hook an 8 oz. scale over the upper end of the lock arm trip and pull to the left. It should require 3/4 to 1-1/2 ozs. to start the lock arm trip moving.

### Printing Contact Screw Adjustment (Figure 20-A)

With the selector bar return lever in its latched position, there should be .004" to .006" clearance between the printing contacts.

Note: After making a single adjustment, check related adjustments.

Adjust by means of the printing contact screw. Tighten the lock nut.

#### Printing Contact Spring Tension (Figure 20-B)

With the printing contacts closed, hook an 8 oz. scale over the upper end of the contact spring just below the fibre block and pull toward the front of the printer. It should require a pull of 3-1/2 to 4 ozs. to separate the contacts.

To adjust, bend the contact spring.

#### Selector Bar Return Lever Adjusting Screw Adjustment (Figure 21)

With the eighth pulse armature arm held against its right stop and the selector bar return lever in its unlatched position, there should be .004" to .008" clearance between the eighth pulse armature arm and the selector carriage push rod nut, when the play in the push rod is taken up in a direction to make this clearance a minimum.

Adjust by means of the selector bar return lever adjusting screw.

Tighten the lock nut. (See Figure 18 for location of parts.)

#### Selector Bar Return Lever Spring Adjustment

In order to check this adjustment it is necessary to remake it. To adjust, connect the printer to the power supply and operate it by transmitting all marking impulses. Back off the spring adjusting screw until the return lever fails to return the selector bars to their unoperated (right-hand) position. Advance the screw just far enough so that the return lever consistently returns the selector bars. Then advance the screw an additional one-quarter turn. (See Figure 18 for location of parts.)

#### Printing Solenoid Plunger Lower Stop Nut Adjustment (Figure 22)

The printing solenoid plunger lower stop nut should be adjusted so that the center of the lower link bearing screw is 1-1/4" (plus or minus 1/32") above the machined surface of the solenoid frame when the plunger is in its uppermost position. It may be necessary to remove the upper link bearing screw in order to raise the plunger to its uppermost position.

Adjust by means of the plunger lower stop nut. Tighten the lock nut and replace the upper link bearing screw if previously removed.

#### Printing Bail Frame Adjustment (Figure 23)

When the printing solenoid plunger is in its uppermost position, the printing bail roller should rest just below the apex of the rise on the pull bars.

To adjust, loosen the printing bail frame clamping screws and rotate the printing bail frame on the printing shaft. At the same time, center the printing bail frame so that the two printing bail roller arms are equidistant from the two end pull bars. Tighten the printing bail frame clamping screws. (See Figure 22 for location of parts.)

---

Note: After making a single adjustment, check related adjustments.

### Cutout Shaft Fingers Adjustment (Figure 13)

The cutout shaft fingers should line up with the buttons on their respective armatures and there should be some clearance, not over .004", between the ends of the fingers and the buttons when the selector magnet armatures are resting against their stop nuts. Make certain that the cutout shaft lever does not interfere with the cutout lever when checking this adjustment. (Figure 16-A).

Adjust the cutout shaft fingers by bending.

### Eighth Pulse Cutout Shaft Spring Tension (Figure 16-A)

With the eighth pulse cutout shaft lever in its unlatched position, it should require a pull of 1/2 to 1-1/2 ozs. to move the cutout shaft fingers away from the armature buttons. To measure, place the printer on its rear side and hook an 8 oz. scale over the cutout shaft spring post at the bend and pull vertically upward.

### Cutout Shaft Lever Position (Figure 16)

When the eighth pulse armature arm is held tightly against its left stop, there should be .002" to .004" clearance between the extreme right edge of the eighth pulse cutout lever and the left edge of the cutout shaft lever (Figure 16-A). Also, when any selector armature is held against its core, the cutout shaft lever should overtravel the latching surface of the cutout lever .002" to .004" (Figure 16-B).

To adjust, loosen the cutout shaft lever clamping screw and position the lever to meet the requirements. Tighten the clamping screw.

### Printing Contact Lock Bracket Adjustment (Figure 18)

With all the selector bars to the left, and the selector bar return lever held in its operated position by the lock arm, there should be a clearance of .010" to .020" between the return lever and the ends of the selector bars.

To adjust, loosen the two printing contact lock bracket mounting screws and position the bracket. Tighten the mounting screws.

### Lock Arm Spring Tension (Figure 19)

With the eighth pulse armature arm held against its left stop, apply the push end of an 8 oz. scale to the right-hand end of the lock arm and push vertically downward. It should require 1-1/2 to 2 ozs. to start the lock arm moving.

### Lock Arm Trip Spring Tension (Figure 19)

Hold the lock restoring arm against its stop screw. Hook an 8 oz. scale over the upper end of the lock arm trip and pull to the left. It should require 3/4 to 1-1/2 ozs. to start the lock arm trip moving.

### Printing Contact Screw Adjustment (Figure 20-A)

With the selector bar return lever in its latched position, there should be .004" to .006" clearance between the printing contacts.

Note: After making a single adjustment, check related adjustments.

Adjust by means of the printing contact screw. Tighten the lock nut.

#### Printing Contact Spring Tension (Figure 20-B)

With the printing contacts closed, hook an 8 oz. scale over the upper end of the contact spring just below the fibre block and pull toward the front of the printer. It should require a pull of 3-1/2 to 4 ozs. to separate the contacts.

To adjust, bend the contact spring.

#### Selector Bar Return Lever Adjusting Screw Adjustment (Figure 21)

With the eighth pulse armature arm held against its right stop and the selector bar return lever in its unlatched position, there should be .004" to .008" clearance between the eighth pulse armature arm and the selector carriage push rod nut, when the play in the push rod is taken up in a direction to make this clearance a minimum.

Adjust by means of the selector bar return lever adjusting screw.

Tighten the lock nut. (See Figure 18 for location of parts.)

#### Selector Bar Return Lever Spring Adjustment

In order to check this adjustment it is necessary to remake it. To adjust, connect the printer to the power supply and operate it by transmitting all marking impulses. Back off the spring adjusting screw until the return lever fails to return the selector bars to their unoperated (right-hand) position. Advance the screw just far enough so that the return lever consistently returns the selector bars. Then advance the screw an additional one-quarter turn. (See Figure 18 for location of parts.)

#### Printing Solenoid Plunger Lower Stop Nut Adjustment (Figure 22)

The printing solenoid plunger lower stop nut should be adjusted so that the center of the lower link bearing screw is 1-1/4" (plus or minus 1/32") above the machined surface of the solenoid frame when the plunger is in its uppermost position. It may be necessary to remove the upper link bearing screw in order to raise the plunger to its uppermost position.

Adjust by means of the plunger lower stop nut. Tighten the lock nut and replace the upper link bearing screw if previously removed.

#### Printing Bail Frame Adjustment (Figure 23)

When the printing solenoid plunger is in its uppermost position, the printing bail roller should rest just below the apex of the rise on the pull bars.

To adjust, loosen the printing bail frame clamping screws and rotate the printing bail frame on the printing shaft. At the same time, center the printing bail frame so that the two printing bail roller arms are equidistant from the two end pull bars. Tighten the printing bail frame clamping screws. (See Figure 22 for location of parts.)

---

Note: After making a single adjustment, check related adjustments.

### Cutout Shaft Fingers Adjustment (Figure 13)

The cutout shaft fingers should line up with the buttons on their respective armatures and there should be some clearance, not over .004", between the ends of the fingers and the buttons when the selector magnet armatures are resting against their stop nuts. Make certain that the cutout shaft lever does not interfere with the cutout lever when checking this adjustment. (Figure 16-A).

Adjust the cutout shaft fingers by bending.

### Eighth Pulse Cutout Shaft Spring Tension (Figure 16-A)

With the eighth pulse cutout shaft lever in its unlatched position, it should require a pull of 1/2 to 1-1/2 ozs. to move the cutout shaft fingers away from the armature buttons. To measure, place the printer on its rear side and hook an 8 oz. scale over the cutout shaft spring post at the bend and pull vertically upward.

### Cutout Shaft Lever Position (Figure 16)

When the eighth pulse armature arm is held tightly against its left stop, there should be .002" to .004" clearance between the extreme right edge of the eighth pulse cutout lever and the left edge of the cutout shaft lever (Figure 16-A). Also, when any selector armature is held against its core, the cutout shaft lever should overtravel the latching surface of the cutout lever .002" to .004" (Figure 16-B).

To adjust, loosen the cutout shaft lever clamping screw and position the lever to meet the requirements. Tighten the clamping screw.

### Printing Contact Lock Bracket Adjustment (Figure 18)

With all the selector bars to the left, and the selector bar return lever held in its operated position by the lock arm, there should be a clearance of .010" to .020" between the return lever and the ends of the selector bars.

To adjust, loosen the two printing contact lock bracket mounting screws and position the bracket. Tighten the mounting screws.

### Lock Arm Spring Tension (Figure 19)

With the eighth pulse armature arm held against its left stop, apply the push end of an 8 oz. scale to the right-hand end of the lock arm and push vertically downward. It should require 1-1/2 to 2 ozs. to start the lock arm moving.

### Lock Arm Trip Spring Tension (Figure 19)

Hold the lock restoring arm against its stop screw. Hook an 8 oz. scale over the upper end of the lock arm trip and pull to the left. It should require 3/4 to 1-1/2 ozs. to start the lock arm trip moving.

### Printing Contact Screw Adjustment (Figure 20-A)

With the selector bar return lever in its latched position, there should be .004" to .006" clearance between the printing contacts.

Note: After making a single adjustment, check related adjustments.

Adjust by means of the printing contact screw. Tighten the lock nut.

#### Printing Contact Spring Tension (Figure 20-B)

With the printing contacts closed, hook an 8 oz. scale over the upper end of the contact spring just below the fibre block and pull toward the front of the printer. It should require a pull of 3-1/2 to 4 ozs. to separate the contacts.

To adjust, bend the contact spring.

#### Selector Bar Return Lever Adjusting Screw Adjustment (Figure 21)

With the eighth pulse armature arm held against its right stop and the selector bar return lever in its unlatched position, there should be .004" to .008" clearance between the eighth pulse armature arm and the selector carriage push rod nut, when the play in the push rod is taken up in a direction to make this clearance a minimum.

Adjust by means of the selector bar return lever adjusting screw.

Tighten the lock nut. (See Figure 18 for location of parts.)

#### Selector Bar Return Lever Spring Adjustment

In order to check this adjustment it is necessary to remake it. To adjust, connect the printer to the power supply and operate it by transmitting all marking impulses. Back off the spring adjusting screw until the return lever fails to return the selector bars to their unoperated (right-hand) position. Advance the screw just far enough so that the return lever consistently returns the selector bars. Then advance the screw an additional one-quarter turn. (See Figure 18 for location of parts.)

#### Printing Solenoid Plunger Lower Stop Nut Adjustment (Figure 22)

The printing solenoid plunger lower stop nut should be adjusted so that the center of the lower link bearing screw is 1-1/4" (plus or minus 1/32") above the machined surface of the solenoid frame when the plunger is in its uppermost position. It may be necessary to remove the upper link bearing screw in order to raise the plunger to its uppermost position.

Adjust by means of the plunger lower stop nut. Tighten the lock nut and replace the upper link bearing screw if previously removed.

#### Printing Bail Frame Adjustment (Figure 23)

When the printing solenoid plunger is in its uppermost position, the printing bail roller should rest just below the apex of the rise on the pull bars.

To adjust, loosen the printing bail frame clamping screws and rotate the printing bail frame on the printing shaft. At the same time, center the printing bail frame so that the two printing bail roller arms are equidistant from the two end pull bars. Tighten the printing bail frame clamping screws. (See Figure 22 for location of parts.)

---

Note: After making a single adjustment, check related adjustments.

### Word-Space Vertical Bar Upstop Adjustment

The word-space pull bar (extreme right) should line up with the tops of the other pull bars.

To adjust, bend the upstop for the word-space vertical bar which is mounted by means of the two printing relay mounting screws.

### Pull Bar Comb Adjustment

When a selected pull bar rests in the bottom of the notches in the selector bars, the clearance on both sides of the pull bar should be approximately equal.

To adjust, position the pull bar comb by means of its mounting screws. Tighten the mounting screws. (See Figure 23 for location of parts.)

### Printing Bail Roller Arms Adjustment (Figure 23)

With the printing solenoid plunger in its unoperated position, there should be .020" to .035" clearance between the selector bars and the upper ends of all pull bars except the bell pull bar. With the platen in the figures position there should be at least .004" clearance between the selector bars and the upper end of the bell pull bar and when the platen is in the letters position, this clearance should not exceed .045".

To adjust, position the printing bail roller arms by means of their mounting screws. Tighten the screws.

### Printing Bail Adjustment (Figure 24)

With the pull bars resting against the selector bars, there should be .002" to .004" clearance between the front edge of the printing bail and the points of the humps on the unselected pull bars.

Adjust by means of the two printing bail mounting screws. Tighten the mounting screws.

### Pull Bar Retaining Bar Adjustment (Figure 23)

With the solenoid plunger in its unoperated position, there should be .025" to .050" clearance between the pull bars and the retaining bar.

Adjust by means of the retaining bar mounting screws. Tighten the screws.

### Printing Solenoid Plunger Upper Stop Nut Adjustment

When the printing solenoid plunger is depressed so that its upper leather washer is held firmly against the printing solenoid frame, the type pallet of any type bar, except the misselection type bar, should be moved to within 1/16" to 1/2" of the platen. Try all type bars.

Adjust by means of the printing solenoid plunger upper stop nut. Lock the upper stop nut in place by means of the upper stop nut lock nut. (See Figures 22 and 31 for location of parts.)

Note: After making a single adjustment, check related adjustments.

### Printing Bail Extension Blade Adjustment (Figure 25)

With the printing bail in its uppermost position and the misselection pull bar hook engaged with the blade of the printing bail extension, the type pallet of the misselection type bar should be moved to within 1/16" to 1/4" of the platen. (See Figure 31 for location of parts.)

When the printing bail extension blade is rotated past the tip of the hook on the misselection pull bar, as the misselection pull bar enters the notch in the selector bars, there should be .015" to .025" clearance between the rear upper edge of the bail extension blade and the point of the hook on the misselection pull bar at the closest point.

Adjust the height of the blade by means of spacer washers under the bail extension blade. There should be an equal number of washers under each side of the blade. After the blade has been adjusted to the proper height, position it for the proper horizontal clearance. The blade should be parallel to the pull bars and the polished portion should be centralized with respect to the misselection pull bar. Tighten the mounting screws. After the screws have been tightened, recheck both adjustments.

Note: It may be necessary to refine the vertical adjustment by loosening the printing bail extension mounting screws and utilizing the play in the bail extension mounting holes. Tighten the mounting screws.

### Lock Restoring Arm Stop Screw Adjustment (Figure 26)

When the selector bar return lever is in its latched position, and the lock restoring arm is against its stop screw, there should be .050" to .070" clearance between the operating face of the lock arm trip and the lock arm.

Adjust by means of the lock restoring arm stop screw and tighten the lock nut.

### Contact Lock Operating Screw Adjustment (Figure 27)

With the printing bail at the end of its downward stroke, there should be .025" to .035" clearance between the right end of the lock arm and the bottom edge of the return lever.

Adjust by means of the operating screw and tighten the lock nut.

### Unblocking Bail Bearing Plate Adjustment (Figure 28)

The unblocking bail should be equidistant from each of the end pull bars when the pull bars are resting against the selector bars but not selected.

To adjust, proceed as follows: Unscrew the unblocking bail stop screw so that it does not interfere with the unblocking bail. Depress the solenoid plunger so that all the pull bars (except the misselection pull bar) rest against the selector bars. To do this, insert an object about 1/8" thick between the solenoid plunger lower stop washer and the solenoid frame. Loosen the screws which mount the unblocking bail bearing plate and position the plate so that the unblocking bail touches both end pull bars. Tighten the screws and then recheck the adjustment to make certain that the plate did not shift when the screws were tightened.

Note: After making a single adjustment, check related adjustments.



### Unblocking Bail Stop Screw Adjustment (Figure 29)

To check this adjustment it is necessary to remake it. With the printer operating on repeat "Blank" combination, loosen the unblocking bail stop screw lock nut and withdraw the screw until a pull bar strikes the unblocking bail causing it to move backward at each operation of the printer. The unblocking bail must follow its stop screw when this adjustment is being made. If necessary, bend the bell crank extension so that the unblocking bail is held against its stop screw through the action of the blocking lever spring. Then advance the stop screw until the unblocking bail just fails to move when the printer is operating on repeat "Blank" combination. Do not advance the screw beyond this point. Tighten the lock nut and recheck the adjustment. See Figure 30 for location of parts.

Note: When this adjustment is properly made, the clearance between the unblocking bail and each pull bar (except the letters, figures, bell, and misselection pull bars) should not exceed .030" when the solenoid plunger is in its unoperated position.

### Blocking Lever Bracket Adjustment (Figure 30)

With the printing solenoid plunger in its unoperated position, there should be .035" to .040" clearance between the rear edge of the misselection pull bar and the blocking edge of the blocking lever (Figure 30-B).

Adjust from the rear of the printer by means of the three left-hand screws in the blocking lever bracket (Figure 30-C). In making this adjustment, the following procedure should be used: If the blocking lever is too far forward, loosen the upper and lower adjusting screws one-half turn each and advance the center screw until it is tight. If this should be insufficient to correct the condition, repeat the same procedure until the blocking lever is correctly positioned. If the blocking lever is too far toward the rear of the printer, unscrew the center adjusting screw one-half turn and tighten the upper and lower screws. Care should be taken that the upper and lower screws are advanced approximately the same amount in tightening. This procedure should be repeated until the blocking lever has been correctly positioned.

### Misselection Mechanism Mounting Plate Adjustment (Figure 30-A)

With the blocking lever in contact with the left stop (looking at the printer from the rear) and the misselection pull bar resting against the blocking lever, the blocking lever should engage the misselection pull bar by 1/2 to 3/4 the thickness of the pull bar. This requirement should be met if the right edge of the blocking lever protrudes .025" to .035" to the right of the misselection pull bar, looking at the printer from the front.

To adjust, loosen the screws which clamp the misselection mechanism mounting plate to the printer side frames and shift the mounting plate. Make certain that the blocking lever is in contact with its stop when making the measurement. Tighten the mounting screws.

---

Note: After making a single adjustment, check related adjustments.

Bell Crank Eccentric Adjustment (Figure 30-C)

With the printing solenoid plunger in its unoperated position, and the unblocking bail resting against its backstop screw, there should be some clearance, not over .002", between the left side of the formed over portion of the blocking lever and the side of the slot in the blocking lever bracket.

Adjust by means of the bell crank eccentric bushing, keeping the high side of the eccentric bushing toward the right. If the range of the eccentric is insufficient to meet the requirements, place the eccentric bushing in the middle of its adjustment range with the high side toward the right. Bend the bell crank extension until the adjustment is approximately correct. Refine this adjustment as previously outlined, using the eccentric bushing.

Blocking Lever Spring Tension

It should require a push of 8 to 12 grams to move the blocking lever from its left-hand stop to its right-hand stop (looking at the unit from the rear) when a gram scale is applied to the end of the unblocking bail and pressure is exerted toward the rear of the unit.

Universal Bar Stop Screw (Figure 31)

When the "T" type bar is pulled forward manually, its lower edge should strike the edge of the universal bar when the type pallet is 1-7/16" to 1-9/16" from the platen.

Adjust by means of the universal bar stop screw. Tighten the lock nut.

Platen Shaft Retainer (Figure 32)

The platen should have some end play, not over .002".

To adjust, loosen the platen shaft retainer mounting screw and position the retainer. Tighten the mounting screw.

Universal Bar Support Spring Tension (Figure 31)

Unhook the universal bar support spring at its forward end and hook a 32 oz. scale in the spring eye. It should require a pull of 12 to 15 ozs. to extend the spring to position length. Replace the spring.

Beam Reset Arm Spring Tension (Figure 31)

Hook an 8 oz. scale over the end of the beam reset arm and pull vertically upward. It should require 5 to 7 ozs. to start the arm moving.

Spacing Detent Spring Tension (Figure 34)

Hook a 32 oz. scale under the head of the spacing detent roller screw and pull vertically upward. It should require 24 to 28 ozs. to start the detent moving.

Note: After making a single adjustment, check related adjustments.

### Beam Reset Arm Adjustment (Figure 33)

To check this adjustment it is necessary to back off the right spacing beam stop screw. Then, with the printing solenoid plunger held partially operated (so that the space connecting rod does not restrict the motion of the spacing beam) the beam reset arm should rotate the spacing beam so that the spacing pawl over-travels a tooth on the ratchet .025" to .030" when the "T" bar is held against the platen.

To adjust, select the "T" type bar, operate the printing solenoid, and hold it in its operated position by inserting a spacer between the solenoid plunger lower washer and the solenoid frame. (As an alternative to this method of holding the printing solenoid operated, the printing shaft spring may be shifted to the hole in the rear of the ribbon feed unit operating arm - See Figure 42). Loosen the two screws that mount the beam reset arm adjusting block and adjust the block to obtain the desired condition (Figure 31). Tighten the mounting screws. Remove the spacer from the solenoid plunger or restore the printing shaft spring to its proper position.

### Word Space Link Adjusting Plate Adjustment (Figure 35)

With the "space" selection set up and with the printing solenoid plunger in its operated (lowermost) position, the spacing pawl should overtravel a tooth on the spacing ratchet by .004" to .010".

To adjust, loosen the word-space link adjusting plate mounting screws and position the plate. Tighten the mounting screws.

### Spacing Beam Right Stop Screw Adjustment (Figure 34)

With the spacing beam in contact with the right spacing beam stop screw, the spacing pawl should overtravel a tooth on the spacing ratchet .015" to .020".

To adjust, hold the spacing beam in contact with the right spacing beam stop screw by depressing the word-space link and position the stop screw to obtain the proper clearance. Tighten the lock nut.

### Spacing Beam Left Stop Screw Adjustment

With the feed pawl engaged with a tooth on the spacing ratchet and the detent roller resting in a hollow between two teeth of the ratchet, the spacing beam should make contact with the left spacing beam stop screw.

Adjust by means of the left spacing beam stop screw. Tighten the lock nut. (See Figure 34 for location of parts.)

### Spacer Ratchet Shaft Collar Adjustment (Figure 36)

There should be some end play, not over .004", in the spacer ratchet shaft.

To adjust, loosen the set screws in the spacer ratchet shaft collar and position the collar. Tighten the set screws.

Note: After making a single adjustment, check related adjustments.

### Space Operating Arm Adjustment (Figure 37)

With the printing solenoid plunger in the unoperated position and the space connecting rod shoulder screw resting in the bottom of the slot in the space connecting rod, there should be some clearance, not over .010", between the spacing beam and the left stop screw.

To adjust, loosen the space operating arm clamping screw and position the arm. At the same time locate the arm on the printing shaft so that the space connecting rod is approximately vertical. Tighten the clamping screw.

### Platen Carriage Tracks Adjustment

The platen carriage should be free from binds and there should be no side play between the carriage frame and the carriage tracks. To check this adjustment, unhook the carriage jockey arm spring from its spring post and move the carriage slowly back and forth with the printer setting in the normal upright position. Replace the carriage jockey arm spring.

To adjust, place the printer on its back and loosen the carriage tracks mounting screws. Position one or both of the carriage tracks to obtain the desired adjustment. Tighten the screws. Replace the carriage jockey arm spring. (See Figure 38 for location of parts.)

### Letters Adjusting Screw Adjustment

With the platen in the letters position, characters should be printed in the center of the platen. Press the type pallet directly against the platen. Make certain that the shift cross arm and the bell adjusting lever (Figure 38) do not prevent the carriage from stopping against the letters adjusting screw (Figure 32).

Adjust by means of the letters adjusting screw, which is accessible from the bottom of the printer. Tighten the lock nut.

### Figures Adjusting Screw Adjustment

With the platen in the letters position, print the letter "W" on the platen. Then with the platen in the figures position, the figure "2" should be in alignment with the letter "W" when figure "2" is printed directly on top of letter "W."

To adjust, loosen the set screw which locks the figures adjusting screw and position the adjusting screw. Tighten the set screw. (See figure 32 for location of parts.)

### Bell Hammer Spring Tension (Figure 39)

With the printer resting on its back, apply the push end of an 8 oz. scale to the formed end of the bell hammer and push horizontally toward the top of the printer. It should require 2 to 4 oz. to start the hammer moving.

---

Note: After making a single adjustment, check related adjustments.

### Shift Cross Arm Adjustment

When the platen is shifted from the letters to the figures position or vice versa, the figures roller should travel equally to either side of the apex of the carriage jockey arm (Figure 38). There should also be a slight clearance between the letters pull bar and the letters roller when the platen is in the figures position, and between the figures pull bar and the figures roller when the platen is in the letters position.

To adjust, position the cross arm by means of its mounting screws. Tighten the screws.

### Carriage Jockey Arm Spring Tension (Figure 40)

With the printer resting on its back, hook a 32 oz. scale over the end of the jockey arm just above the detent slope and pull at a right angle to the lever. It should require 11 to 13 ozs. to start the arm moving.

### Bell Adjusting Lever Position

With the platen in the figures position (forward), there should be some clearance, not over .010", between the bell pull bar and the bell adjusting lever when the bell pull bar is held in a position to make this clearance a maximum.

To adjust, loosen the bell adjusting lever mounting screw and position the lever. Tighten the screw. (See Figure 38 for location of parts.)

### Bell Hammer Bracket Adjustment

With the platen in the figures position, select the bell pull bar and raise the printing bail to its uppermost position. There should be .010" to .060" clearance between the bell hammer and the bell.

To adjust, loosen the two screws which mount the bell hammer bracket and swivel the bracket about its dowel pin until the desired adjustment is obtained. Tighten the screws. (See Figures 38 and 39 for location of parts.)

### Misselection Gong Adjustment

With the hook of the misselection pull bar engaged with the printing bail extension blade, raise the printing bail to its uppermost position. There should be .010" to .060" clearance between the gong hammer and the gong. (See Figures 25 and 38 for location of parts.)

To adjust, rest the printer on its back, loosen the gong mounting nut and position the gong mounting screw in its elongated slot. Tighten the nut.

Note: In case the mounting screw turns when the nut is tightened, turn the nut friction tight and then remove the gong and bracket from the printer by removing the two screws from the gong mounting bracket. Hold the gong mounting screw head with a screw driver and tighten the nut. Remount the gong and bracket. (See Figure 38 for location of parts.)

---

Note: After making a single adjustment, check related adjustments.

### Misselection Gong Hammer Spring Tension

With the printer resting on its back, apply the push end of an 8 oz. scale to the formed end of the gong hammer and push horizontally toward the top of the printer. It should require 2 to 4 ozs. to start the hammer moving. (See Figure 38 for location of parts.)

### Eighth Pulse Relay and Printing Relay Adjustments (Figure 41)

The eighth pulse relay and the printing relay should be adjusted to meet the following requirements:

1. With the contacts closed, there should be a clearance of .002" to .004" between the armature and the magnet core.
2. With the armature resting against the backstop nut, there should be a clearance of .010" to .015" between the contact points.
3. When the push end of an 8 oz. scale is applied vertically at a point on the armature just back of the backstop nut, it should require 1 to 1-1/2 ozs. to just start the armature moving.

Adjust the contact screw to meet the requirement of item 1. The requirement of item 2 may be met by adjusting the backstop nut. The proper spring tension requirement (item 3) may be obtained by positioning the armature spring bracket on its mounting screw. It will be necessary to remove the printing relay from the printer frame in order to make the last adjustment properly.

### Ribbon Feed Unit Operating Arm Adjustment (Figure 42) - See Note (A)

With the printing solenoid in its unoperated position, unhook the printing shaft spring from its spring post and hook a 12 lb. scale in the spring eye. To do this, set the printer so that its right side is flush with the edge of the table and pull downward. It should require a pull of 4-3/4 to 5 lbs. to extend the spring to its installed length.

To adjust, loosen the ribbon feed unit operating arm clamping screw and position the arm to obtain the required tension. Hold the printing bail in its unoperated position when tightening the clamping screw.

### Ribbon Feed Operating Lever Spring Tension (Figure 42) - See Note (A)

Unhook the ribbon feed operating lever spring from its upper spring post and hook a 32 oz. scale in the spring eye. Pulling vertically upward, it should require 18 to 22 ozs. to extend the spring to its installed length.

### Feed Pawl Reverse Rod Detent Spring Adjustment (Figure 43) - See Note (A)

With the feed pawl reverse rod detent spring in the left notch of the feed pawl reverse rod, the distance from the reverse arm pin to the top edge of the left

(A) In order to facilitate this measurement and adjustment, remove the tape container.

Note: After making a single adjustment, check related adjustments.

lug on the reverse rod arm should be equal to the distance from this same pin to the top edge of the right-hand lug when the reverse rod is moved so that the detent spring is in the right-hand notch.

To adjust, loosen the reverse rod detent spring mounting screws and position the detent spring. Tighten the mounting screws. (See Figure 45 for location of parts.)

#### Feed Pawl Reverse Rod Detent Spring Tension (Figure 45) - See Note (B)

With the feed pawl reverse rod detent spring in the right-hand reverse rod notch, hook a 32 oz. scale over the reverse rod connecting link screw nut and pull horizontally toward the right. It should require 16 to 20 ozs. to move the reverse rod from the right-hand notch to the left-hand notch position.

#### Ribbon Feed Operating Lever Adjustment (Figure 44)

With the printing solenoid plunger in its unoperated position, the ribbon feed pawl and the retaining pawl should be separated by seven ratchet teeth plus approximately one-half tooth overtravel.

To adjust, loosen the ribbon feed operating lever clamping screw and position the ribbon feed shaft. Tighten the clamping screw (Figure 45).

#### Ribbon Feed Reversing Arm Adjustment (Figure 42) - See Note (B)

With the printing solenoid plunger in its normal unoperated position, and the feed pawl reverse rod detent spring resting in the left-hand notch of the reverse rod, the hooked end of the ribbon reverse pawl should clear the right-hand lug on the reverse rod arm by .010" to .035". (See Figure 45 for location of parts.)

To adjust, loosen the ribbon feed reversing arm clamping screw and position the reversing arm. Tighten the clamping screw.

#### Ribbon Reverse Arms Adjustment (Figure 46) - See Notes (A) and (B)

- a. With the left-hand ribbon reverse arm resting against the left-hand ribbon spool head, and the feed pawl reverse rod detent spring resting in the right-hand notch of the feed pawl reverse rod (Figure 45), the center of the formed portion of the ribbon reverse pawl should be directly above the left-hand lug on the reverse rod arm.

To adjust, loosen the left-hand ribbon reverse arm set screw and position the arm. Tighten the set screw.

- b. With the right-hand ribbon reverse arm resting against the right-hand ribbon spool head, and the feed pawl reverse rod detent spring resting in the left-hand notch of the feed pawl reverse rod, the center of the formed portion of the ribbon reverse pawl should be directly above the right-hand lug on the reverse arm.

Adjust in the same manner used to adjust the left-hand ribbon reverse arm.

(A) In order to facilitate this adjustment, remove the ribbon reverse shaft detent spring.

(B) In order to facilitate this adjustment, remove the tape container.

Note: After making a single adjustment, check related adjustments.

### Ribbon Spool Shaft Collar Adjustments (Figure 45) - See Note (A)

Remove the ribbon spools from the printer (Figure 42). With the feed pawl and retaining pawl not engaged with the ratchet, hook an 8 oz. scale over the ribbon spool head post and pull in a horizontal direction at right angles to a radius of the ribbon spool head. It should require 2 to 2-1/2 ozs. to start the shaft turning. Measure the tension required to rotate both ribbon spool shafts.

To adjust, shift the feed pawl reverse rod so as to disengage the pawls from the ratchet and position the ribbon spool shaft collar to obtain the desired friction.

Note: The ribbon spool shafts should be approximately flush with the hubs of their respective ratchets. Adjust by means of the ratchet set screws (Figure 42).

### Ribbon Spool Head Adjustment (Figure 47)

With the ribbon reverse arm in contact with the ribbon spool head, there should be .010" to .030" clearance between the ribbon reverse arm and the head of the set screw in the ribbon spool head when the screw is opposite the ribbon reverse arm. Check both ribbon spool heads.

To adjust, loosen the ribbon spool head set screw and position the ribbon spool head. Tighten the set screw.

### Ribbon Reverse Shaft Detent Collar Adjustment

The ribbon reverse shaft detent spring should engage the notches of the detent collar equally when the ribbon reverse arms are in either position.

To adjust, loosen the detent collar set screw and position the detent collar. Tighten the set screw. (See Figure 45 for location of parts.)

### Ribbon Reverse Shaft Detent Spring Tension (Figure 45) - See Note (A)

With the right-hand ribbon reverse arm in the downward position, hook a 32 oz. scale directly above the indent in the detent spring and pull toward the right. It should require from 16 to 20 ozs. to start the detent spring moving.

### Ribbon Feed Stop Screw Adjustment - See Note (A)

Each time the printing solenoid plunger is operated, the feed pawls should move over 1-1/2 to 2-1/2 teeth of their respective ribbon feed ratchets (Figure 44).

Adjust by limiting the stroke of the ribbon feed reversing arm with the ribbon feed stop screw. Tighten the lock nut. (See Figures 42 and 45 for location of parts.)

### Ribbon Feed Pawl and Retaining Pawl Spring Tension (Figure 44) - See Note (A)

To measure a feed or retaining pawl spring tension, place the pawls in the engaged position. Apply the push end of an 8 oz. scale to the pawl directly above

(A) In order to facilitate this measurement and adjustment, remove the tape container.

Note: After making a single adjustment, check related adjustments.



lug on the reverse rod arm should be equal to the distance from this same pin to the top edge of the right-hand lug when the reverse rod is moved so that the detent spring is in the right-hand notch.

To adjust, loosen the reverse rod detent spring mounting screws and position the detent spring. Tighten the mounting screws. (See Figure 45 for location of parts.)

#### Feed Pawl Reverse Rod Detent Spring Tension (Figure 45) - See Note (B)

With the feed pawl reverse rod detent spring in the right-hand reverse rod notch, hook a 32 oz. scale over the reverse rod connecting link screw nut and pull horizontally toward the right. It should require 16 to 20 ozs. to move the reverse rod from the right-hand notch to the left-hand notch position.

#### Ribbon Feed Operating Lever Adjustment (Figure 44)

With the printing solenoid plunger in its unoperated position, the ribbon feed pawl and the retaining pawl should be separated by seven ratchet teeth plus approximately one-half tooth overtravel.

To adjust, loosen the ribbon feed operating lever clamping screw and position the ribbon feed shaft. Tighten the clamping screw (Figure 45).

#### Ribbon Feed Reversing Arm Adjustment (Figure 42) - See Note (B)

With the printing solenoid plunger in its normal unoperated position, and the feed pawl reverse rod detent spring resting in the left-hand notch of the reverse rod, the hooked end of the ribbon reverse pawl should clear the right-hand lug on the reverse rod arm by .010" to .035". (See Figure 45 for location of parts.)

To adjust, loosen the ribbon feed reversing arm clamping screw and position the reversing arm. Tighten the clamping screw.

#### Ribbon Reverse Arms Adjustment (Figure 46) - See Notes (A) and (B)

- a. With the left-hand ribbon reverse arm resting against the left-hand ribbon spool head, and the feed pawl reverse rod detent spring resting in the right-hand notch of the feed pawl reverse rod (Figure 45), the center of the formed portion of the ribbon reverse pawl should be directly above the left-hand lug on the reverse rod arm.

To adjust, loosen the left-hand ribbon reverse arm set screw and position the arm. Tighten the set screw.

- b. With the right-hand ribbon reverse arm resting against the right-hand ribbon spool head, and the feed pawl reverse rod detent spring resting in the left-hand notch of the feed pawl reverse rod, the center of the formed portion of the ribbon reverse pawl should be directly above the right-hand lug on the reverse arm.

Adjust in the same manner used to adjust the left-hand ribbon reverse arm.

(A) In order to facilitate this adjustment, remove the ribbon reverse shaft detent spring.

(B) In order to facilitate this adjustment, remove the tape container.

Note: After making a single adjustment, check related adjustments.

Ribbon Spool Shaft Collar Adjustments (Figure 45) - See Note (A)

Remove the ribbon spools from the printer (Figure 42). With the feed pawl and retaining pawl not engaged with the ratchet, hook an 8 oz. scale over the ribbon spool head post and pull in a horizontal direction at right angles to a radius of the ribbon spool head. It should require 2 to 2-1/2 ozs. to start the shaft turning. Measure the tension required to rotate both ribbon spool shafts.

To adjust, shift the feed pawl reverse rod so as to disengage the pawls from the ratchet and position the ribbon spool shaft collar to obtain the desired friction.

Note: The ribbon spool shafts should be approximately flush with the hubs of their respective ratchets. Adjust by means of the ratchet set screws (Figure 42).

Ribbon Spool Head Adjustment (Figure 47)

With the ribbon reverse arm in contact with the ribbon spool head, there should be .010" to .030" clearance between the ribbon reverse arm and the head of the set screw in the ribbon spool head when the screw is opposite the ribbon reverse arm. Check both ribbon spool heads.

To adjust, loosen the ribbon spool head set screw and position the ribbon spool head. Tighten the set screw.

Ribbon Reverse Shaft Detent Collar Adjustment

The ribbon reverse shaft detent spring should engage the notches of the detent collar equally when the ribbon reverse arms are in either position.

To adjust, loosen the detent collar set screw and position the detent collar. Tighten the set screw. (See Figure 45 for location of parts.)

Ribbon Reverse Shaft Detent Spring Tension (Figure 45) - See Note (A)

With the right-hand ribbon reverse arm in the downward position, hook a 32 oz. scale directly above the indent in the detent spring and pull toward the right. It should require from 16 to 20 ozs. to start the detent spring moving.

Ribbon Feed Stop Screw Adjustment - See Note (A)

Each time the printing solenoid plunger is operated, the feed pawls should move over 1-1/2 to 2-1/2 teeth of their respective ribbon feed ratchets (Figure 44).

Adjust by limiting the stroke of the ribbon feed reversing arm with the ribbon feed stop screw. Tighten the lock nut. (See Figures 42 and 45 for location of parts.)

Ribbon Feed Pawl and Retaining Pawl Spring Tension (Figure 44) - See Note (A)

To measure a feed or retaining pawl spring tension, place the pawls in the engaged position. Apply the push end of an 8 oz. scale to the pawl directly above

(A) In order to facilitate this measurement and adjustment, remove the tape container.

Note: After making a single adjustment, check related adjustments.

its support and push horizontally toward the middle of the printer. It should require 2 to 6 ozs. to start the pawl moving.

#### Printing Break Contact Screw Adjustment (Figure 48)

In order to check this adjustment it is necessary to remake it. To adjust, apply power to the printer and hold down the first, second, and seventh selector armatures. Advance the printing break contact screw until the printer fails to clear out, then back off the screw until the printer just clears out. Back off the screw an additional one-half turn and lock the screw with its lock nut.

#### Printing Break Contact Spring Tension (Figure 49)

With the printing solenoid plunger in the unoperated position (up), hook an 8 oz. scale over the printing break contact spring between the insulator and the contact point and pull vertically downward. It should require 3 to 4 ozs. to just separate the contacts.

To adjust, bend the contact spring.

#### Contact Break Arm Spring Tension (Figure 49)

With the printing solenoid plunger in the unoperated position (up) hook an 8 oz. scale over the rear end of the contact break arm in line with the rear edge of its mounting bracket and pull vertically downward. It should require 1-1/2 to 2-1/2 ozs. to start the arm moving.

#### Printing Bail Spring Tension Adjustment

The printing blow, i.e., the force with which the type bars strike the platen, can be adjusted by means of the printing bail springs adjusting screws (Figure 22).

To adjust, loosen the adjusting screw lock nuts and advance the screws (lower the spring tension) until the printing becomes faint. Then withdraw the screws (increase the spring tension) until all characters are printed distinctly. Adjust both screws simultaneously to approximately the same position. Tighten the adjusting screw lock nuts.

#### Tape Out Contact Adjustment (Figure 50) - See Note (A)

- (a) When the insulator on the tape lever is resting against the tape out contact spring and the contacts are closed there should be 1/4" (plus or minus 1/32") between the tape lever roller and the tape roller.

To adjust, loosen the contact screw lock nut and position the contact screw. Tighten the lock nut.

- (b) When the tape lever is held away from the contact spring, there should be .015" to .025" contact gap.

To adjust, bend the light contact spring (See Figure 50 for location of parts.)

- (A) In order to facilitate this measurement and adjustment, remove the tape container.

Note: After making a single adjustment, check related adjustments.

Tape Lever Spring Tension (Figure 50) - See Note (A)

Hook the pull end of an 8 oz. scale over the tape lever just below the insulator and pull horizontally toward the rear of the printer. It should require 3 to 4 ozs. to start the insulator moving away from the contact spring.

Misselection Pull Bar Spring Adjustment

To check this adjustment it is necessary to remake it. With the printer operating, hold the unblocking bail against its stop screw so that the misselection pull bar will be engaged by the bail extension blade repeatedly. Shift the misselection pull bar spring to the position on the spring post which provides the best printing of the error symbol and the best audible signal.

---

(A) In order to facilitate this measurement and adjustment, remove the tape reel.

Note: After making a single adjustment, check related adjustments.

## LUBRICATION SPECIFICATION

Proper attention to lubrication is of the utmost importance. If the moving parts of the printer are properly lubricated, wear will be minimized and it will operate for long periods without readjustment. An excessive amount of oil is undesirable. After lubricating the printer, wipe off any excessive oil from the magnet coils and cores, armatures, all contact points, type bars, the type bar segment platen, and the printer base.

The oil and grease specified in the supplement furnished with this bulletin should be used to lubricate this unit. Unless otherwise specified, one or two drops of oil at each of the places indicated will be sufficient. Use oil for lubrication at all of the places listed below, except where the use of grease or oil-grease-oil is specified.

### GENERAL

Oil both loops of all helical springs that exert a nominal tension of less than 2-1/2 pounds.

Apply grease to both loops of all helical springs that exert a nominal tension of 2-1/2 pounds or more.

1. Selector armature - at bearing points.
2. Selector bar pawls and latches - at pivots.
3. Selector bars - at both ends.
4. Cutout shaft - at pivot points.
5. Eighth pulse cutout lever - at bearing end.
6. Eighth pulse armature arm - at bearing point.
7. Selector carriage push rod - sliding surface.
8. Selector bar return lever - at pivot.
9. Lock arm - at shoulder screw.
10. Lock arm trip - at shoulder screw.
11. Lock restoring arm - at shoulder screw.
12. Bail roller - two ends - also a little on surface.
13. Ribbon spool shafts - two bearing ends.
14. Ribbon feed shaft - two bearing ends.
15. Feed pawl reverse rod - two bearing ends.
16. Ribbon reverse shafts - at bearing surface.
17. Ribbon guide - at sliding surface.
18. Tape pressure rollers - at bearing surfaces.
19. Carriage frame - front end sliding surface.
20. Platen shaft - at front end of platen shaft retainer.
21. Type bars - at segment slot.
22. Printing shaft - two oil holes at either end.
23. Ribbon feed unit connecting link - at both ends.
24. Eighth pulse relay armature - pivot point.
25. Printing relay armature - pivot point.
26. Printing solenoid plunger - sliding surface.
27. Plunger link - two bearing ends.
28. Space connecting rod - upper and lower ends.
29. Spacing detent roller.
30. Spacing detent - at pivot.
31. Spacing pawl - at pivot.
32. Spacing beam - at bearing surface.
33. Unblocking bail - at end bearings.
34. Blocking lever - at shoulder screw and top surface of blocking lever plate.

35. Bell crank - at shoulder screw.
36. Bell crank extension - at sliding surface - film of grease.
37. Printing bail extension blade - at polished surface - grease.
38. Word-space linkage - at shoulder screws and at wearing surfaces of adjusting plate and slotted link.

To oil the following, place the printer on its rear side.

39. Beam reset arm - at pivot point and at link.
40. Universal bar support - at pivot point and at link.
41. Carriage tracks.
42. Carriage cross arm - "letters" and "figures" rollers.
43. "Letters" and "figures" pull bars - at bottom ends in slot.
44. Bell hammer - at pivot point.
45. Gong hammer - at pivot point.

U.C.	-	?	:	\$	3	!	&	#	8	(	.	,	9	0	1	4	7	5	7	2	6	W	S	,	.	SPACE	
L.C.	A	B	C	D	E	F	G	H	I	J	K	L	M	N	O	P	Q	R	S	T	U	V	W	X	Y	Z	SPACE
1	●	○	○	○	○	○	○	○	○	○	○	○	○	○	○	○	○	○	○	○	○	○	○	○	○	○	○
2	○	○	○	○	○	○	○	○	○	○	○	○	○	○	○	○	○	○	○	○	○	○	○	○	○	○	○
3	○	○	○	○	○	○	○	○	○	○	○	○	○	○	○	○	○	○	○	○	○	○	○	○	○	○	○
4	○	○	○	○	○	○	○	○	○	○	○	○	○	○	○	○	○	○	○	○	○	○	○	○	○	○	○
5	○	○	○	○	○	○	○	○	○	○	○	○	○	○	○	○	○	○	○	○	○	○	○	○	○	○	○
6	○	○	○	○	○	○	○	○	○	○	○	○	○	○	○	○	○	○	○	○	○	○	○	○	○	○	○
7	○	○	○	○	○	○	○	○	○	○	○	○	○	○	○	○	○	○	○	○	○	○	○	○	○	○	○

FIGURE 1

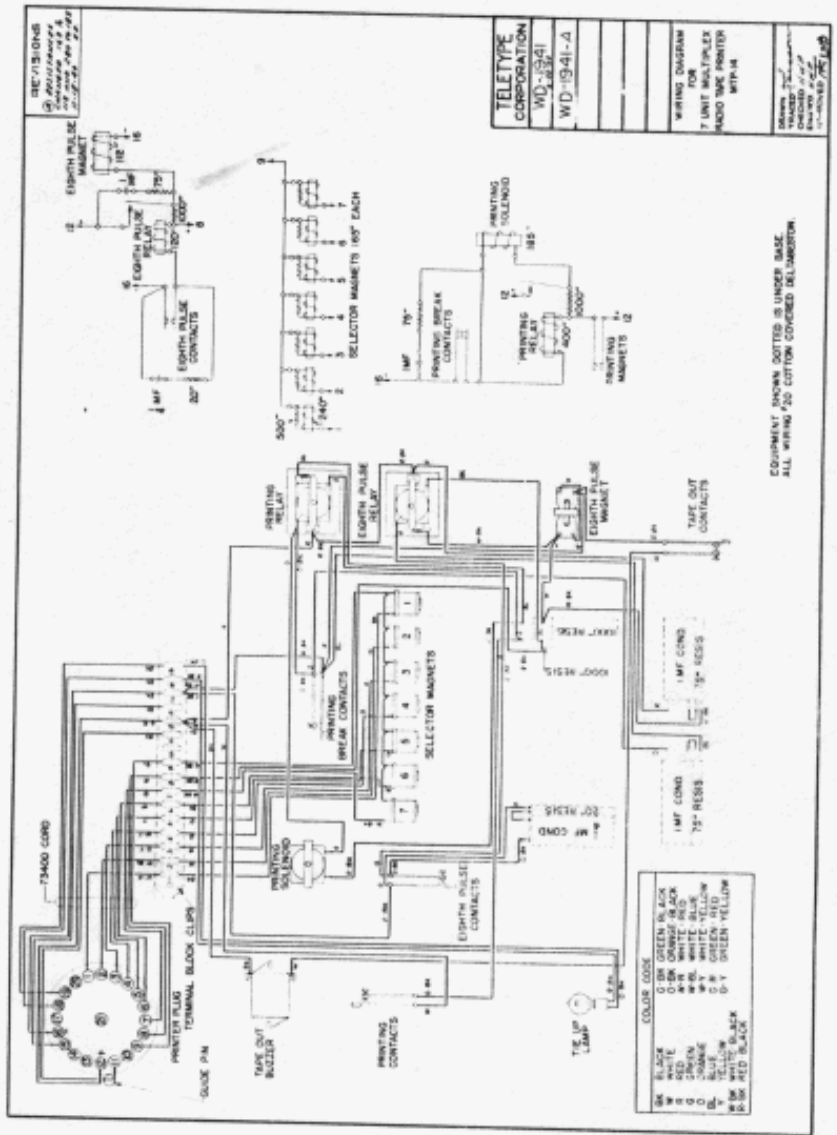

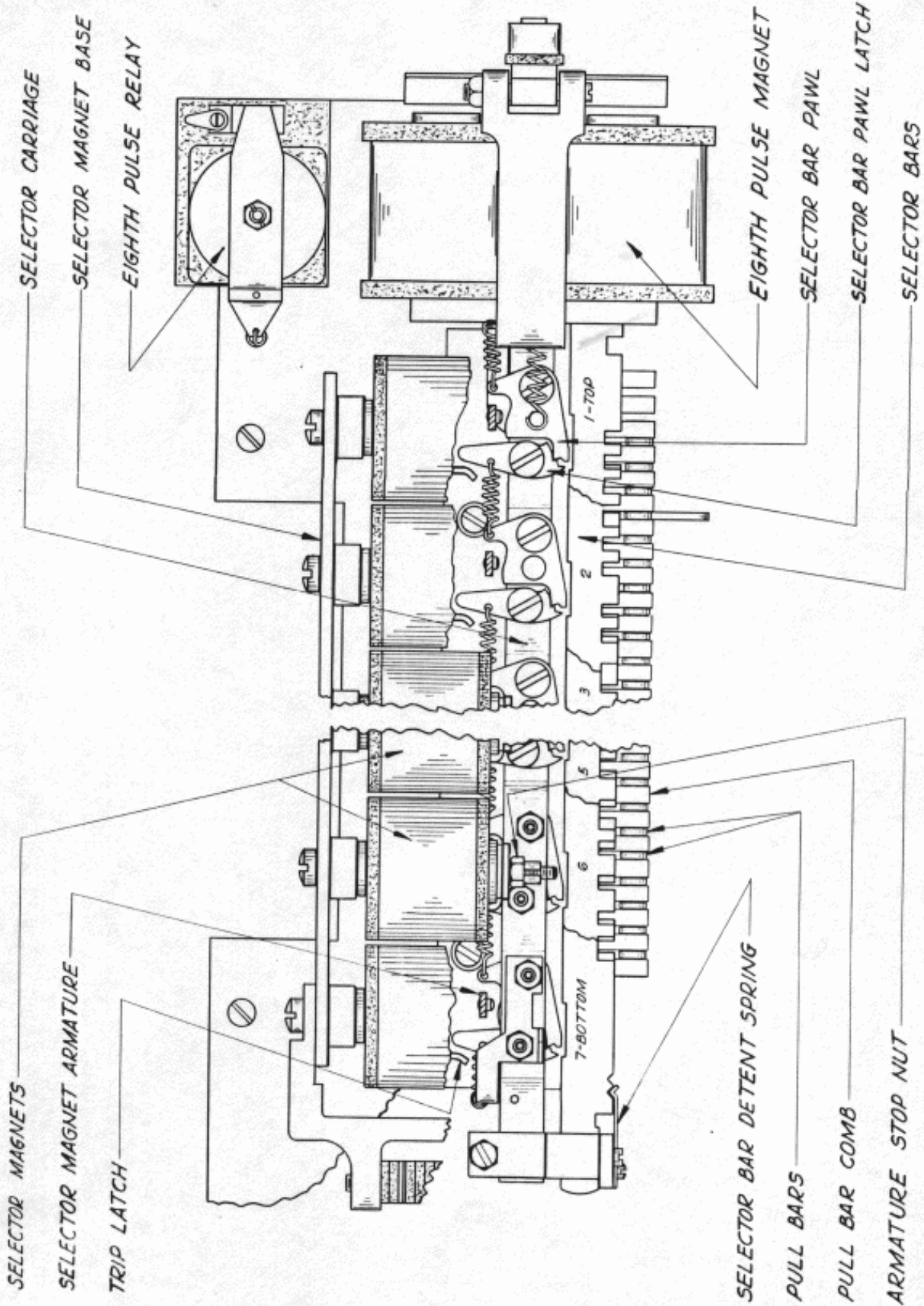

FIGURE 2



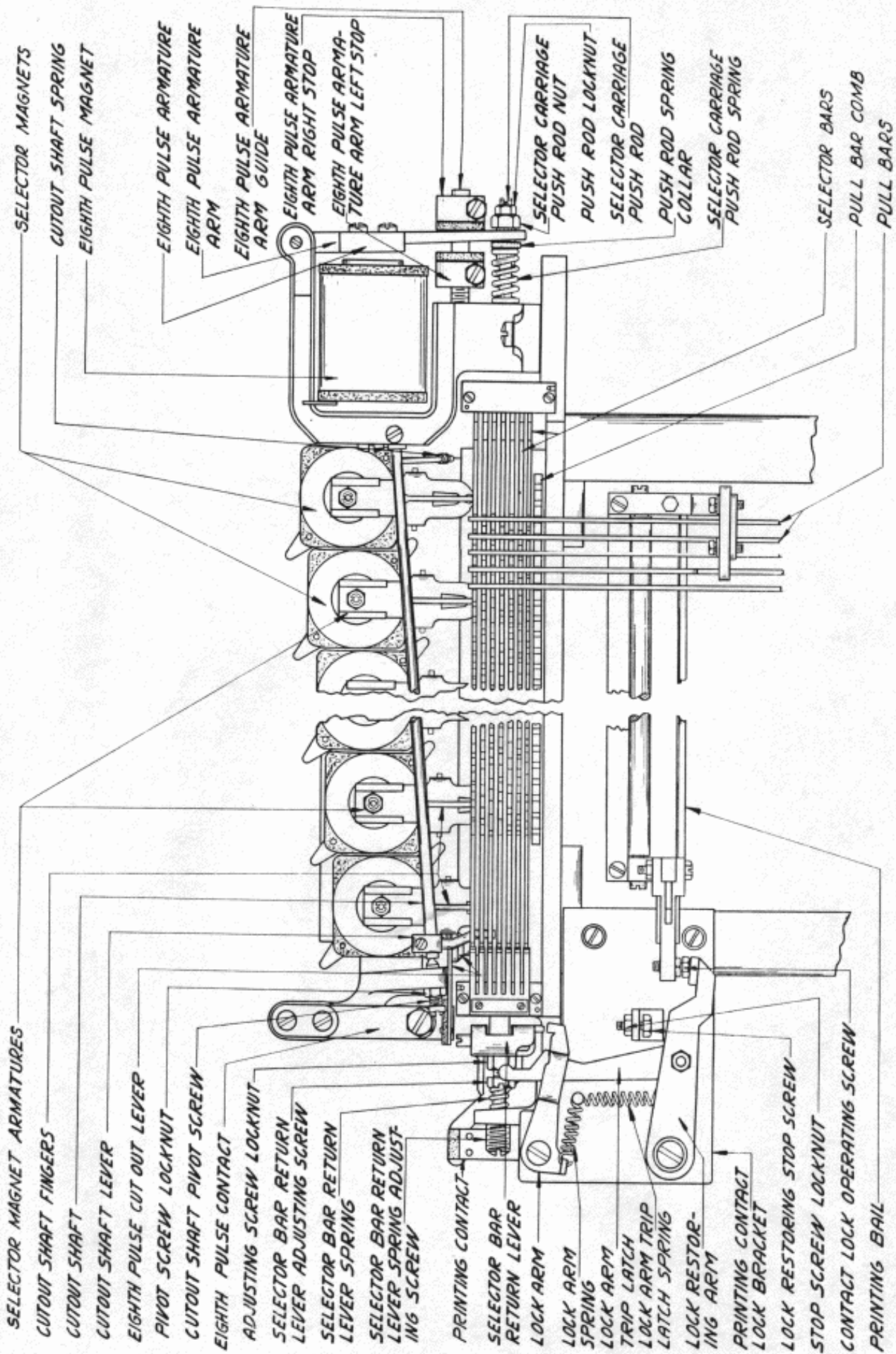

FIGURE 3

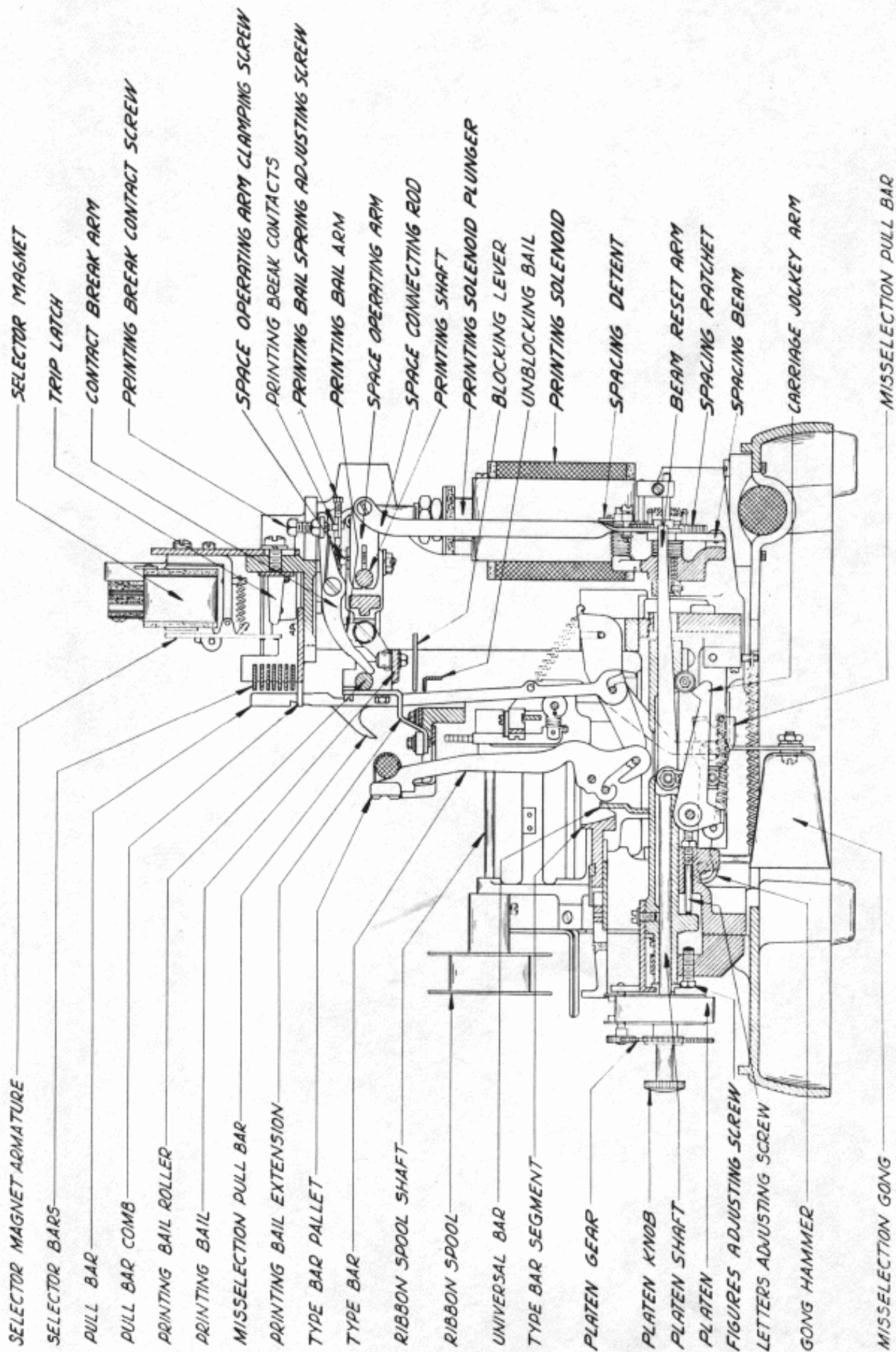

FIGURE 4

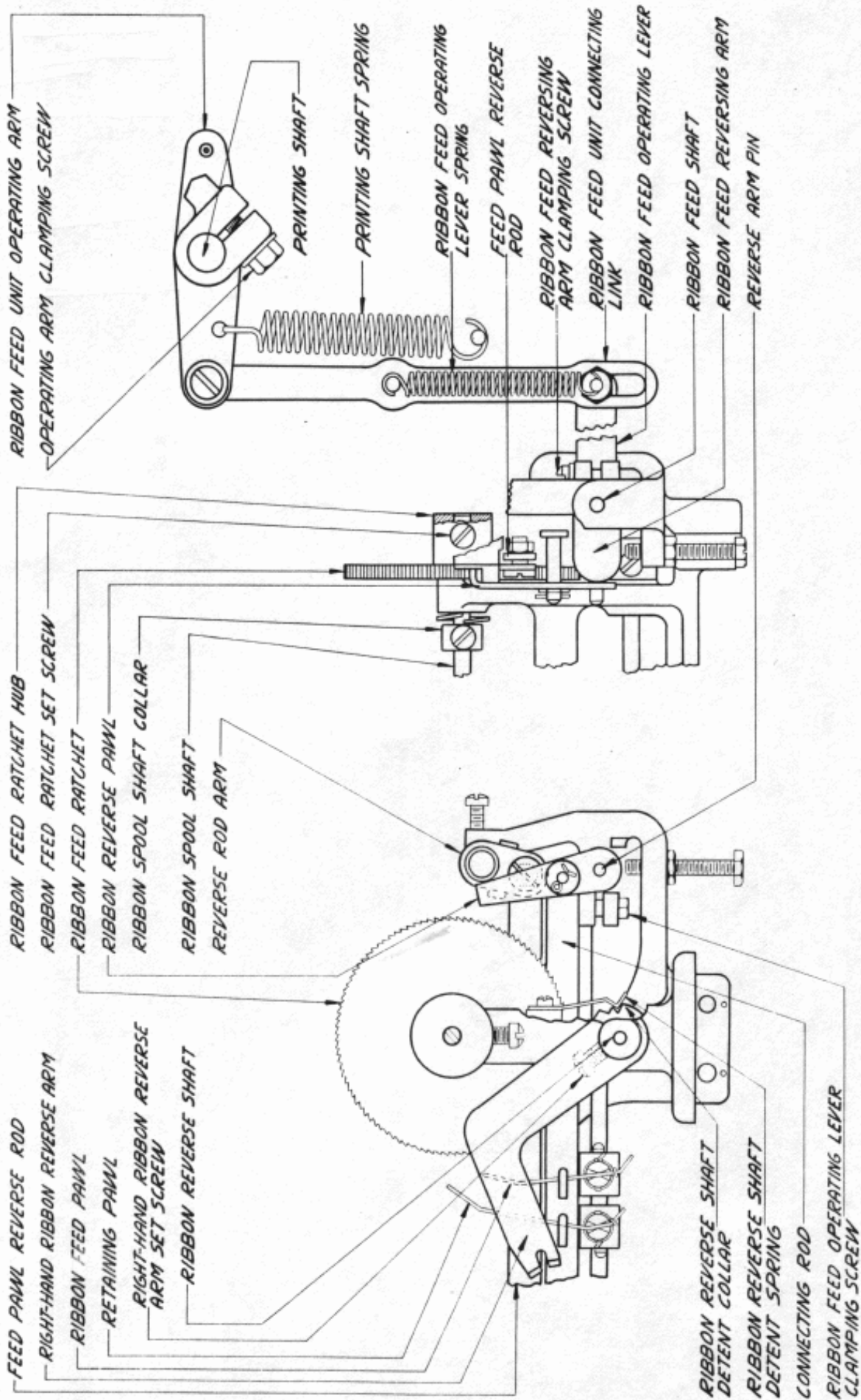

FIGURE 5

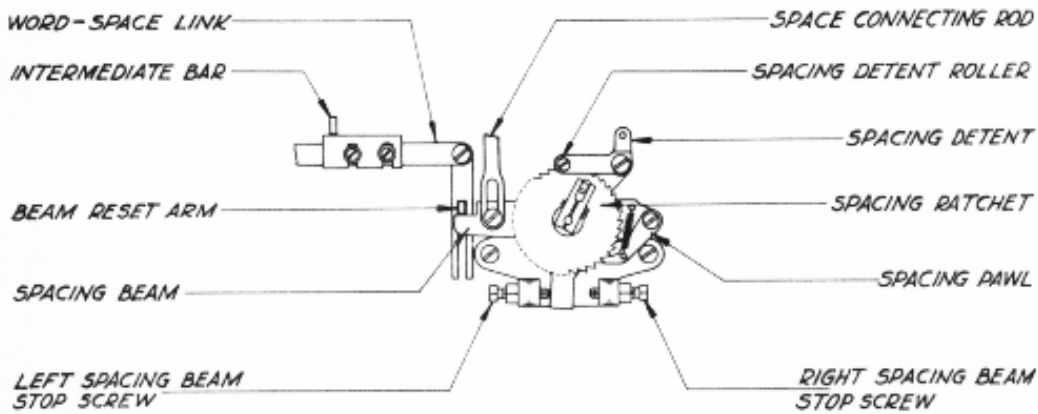

FIGURE 6

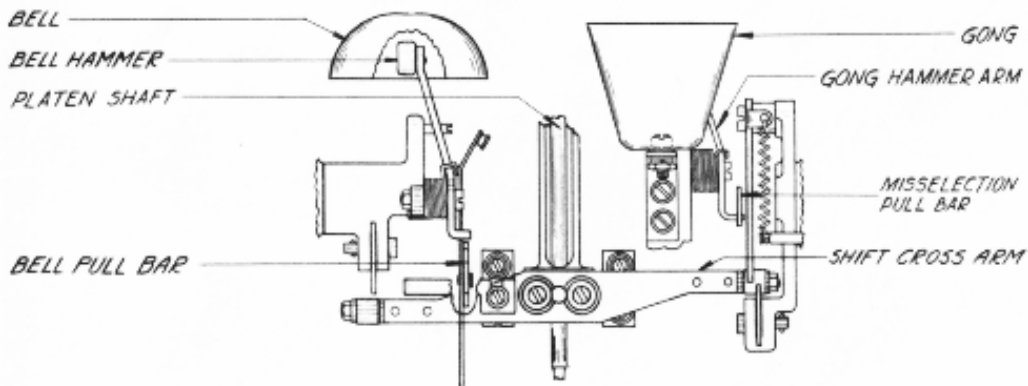
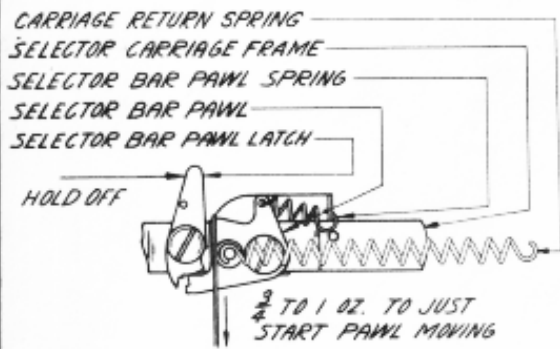
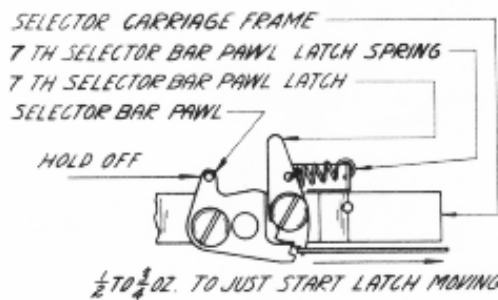

FIGURE 7



(A)



(B)

FIGURE 8

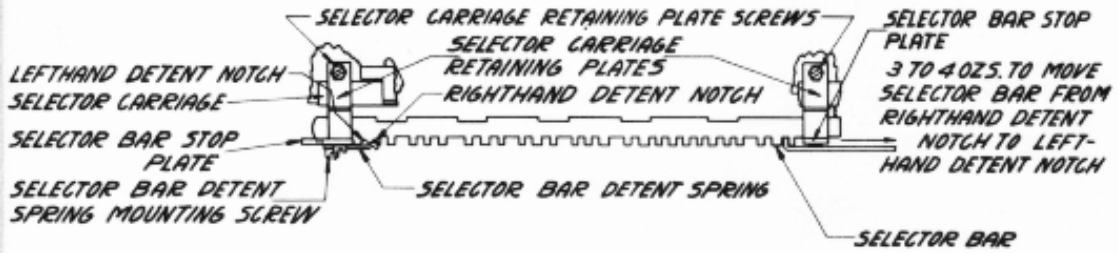

FIGURE 9

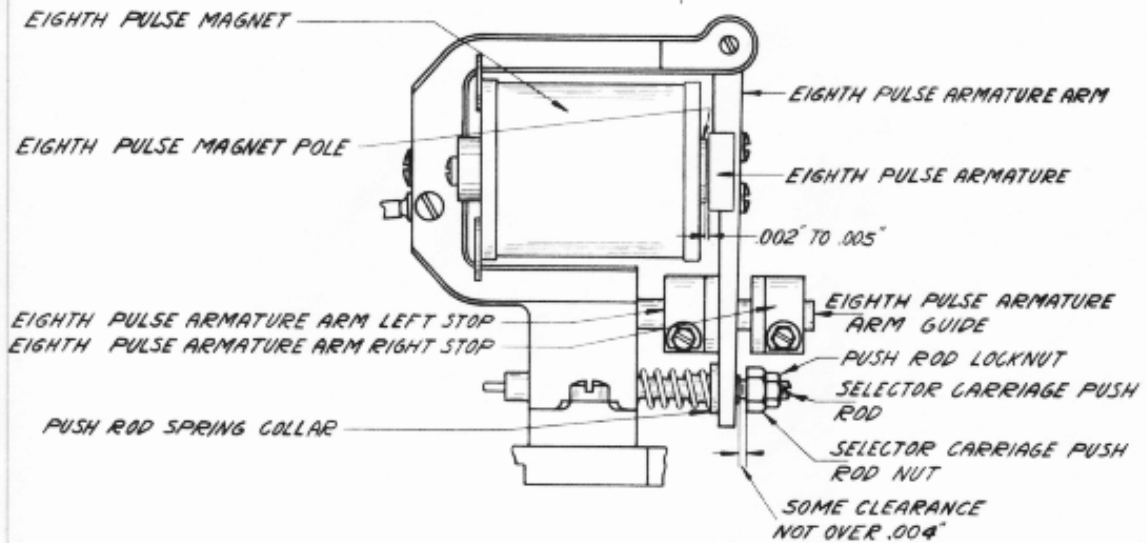

FIGURE 10

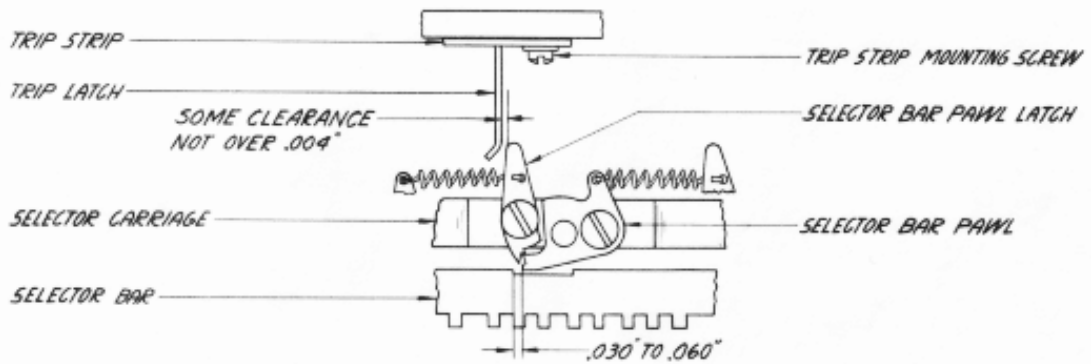

FIGURE 11

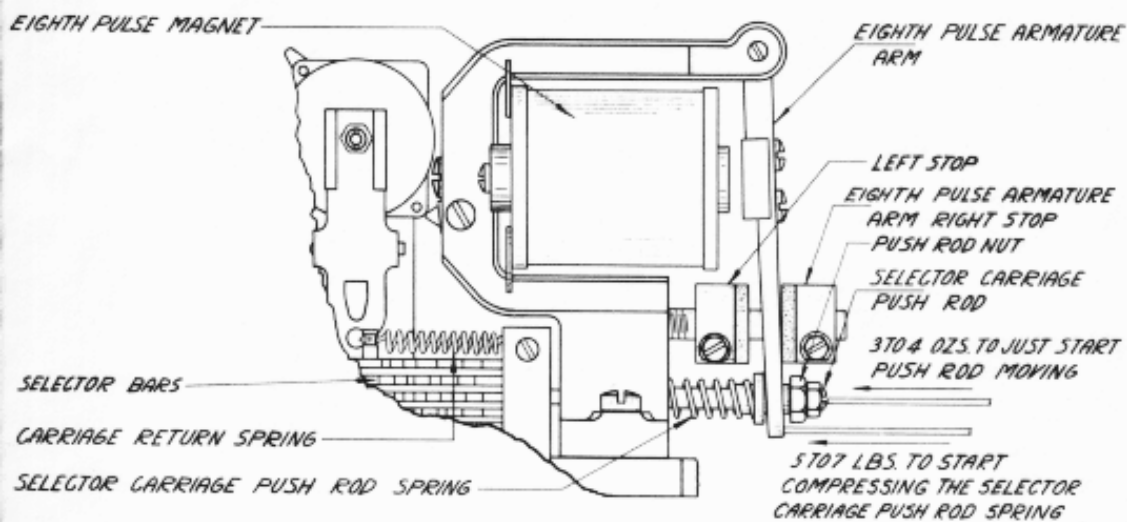

FIGURE 12

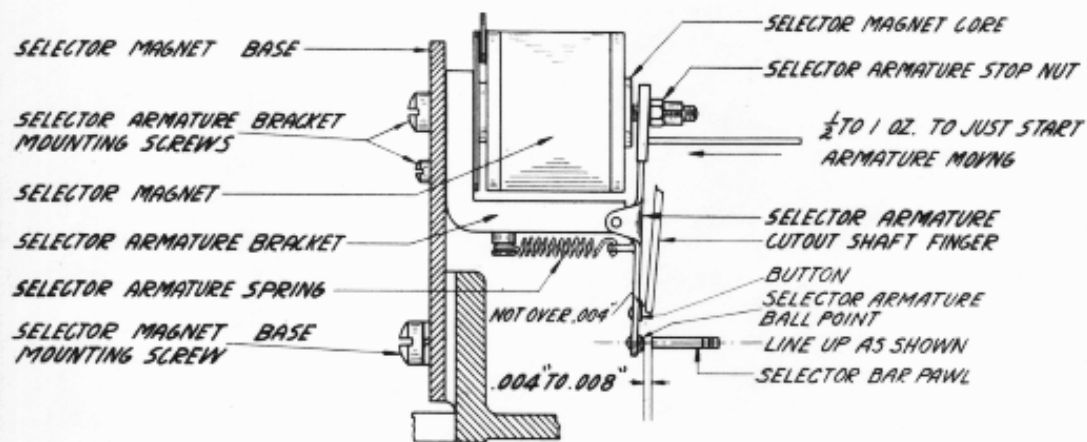

FIGURE 13

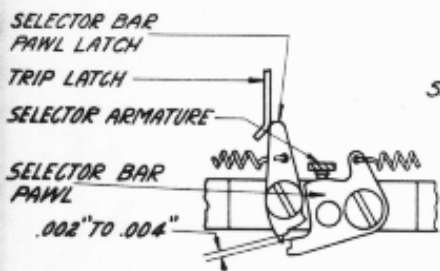

FIGURE 14

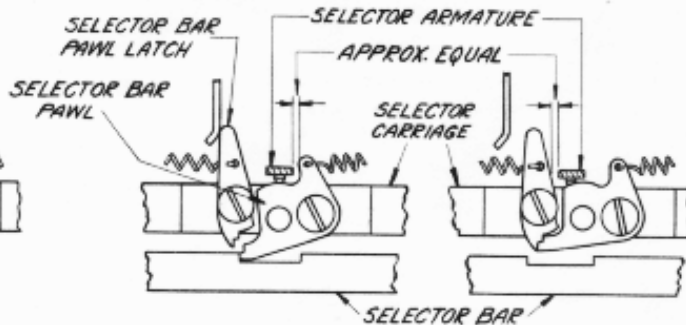

FIGURE 15

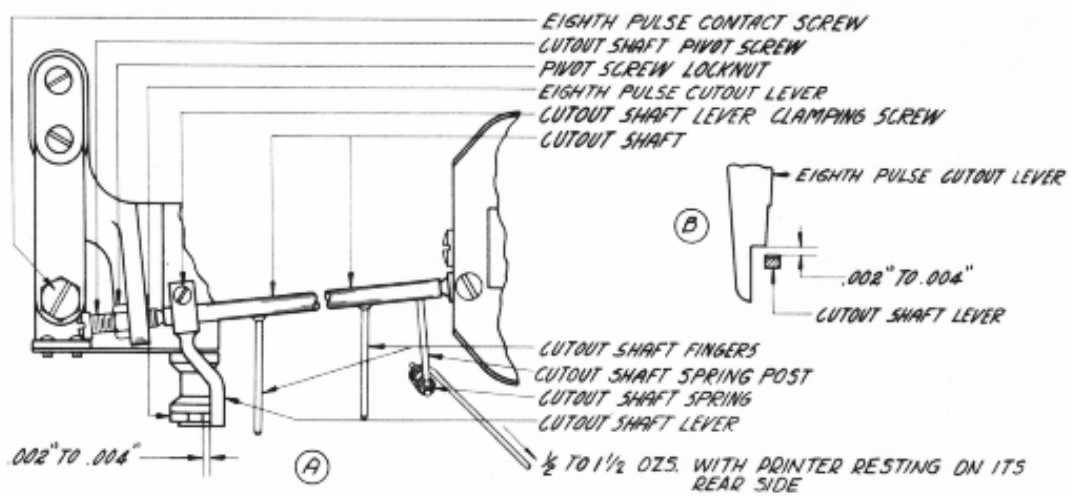

FIGURE 16

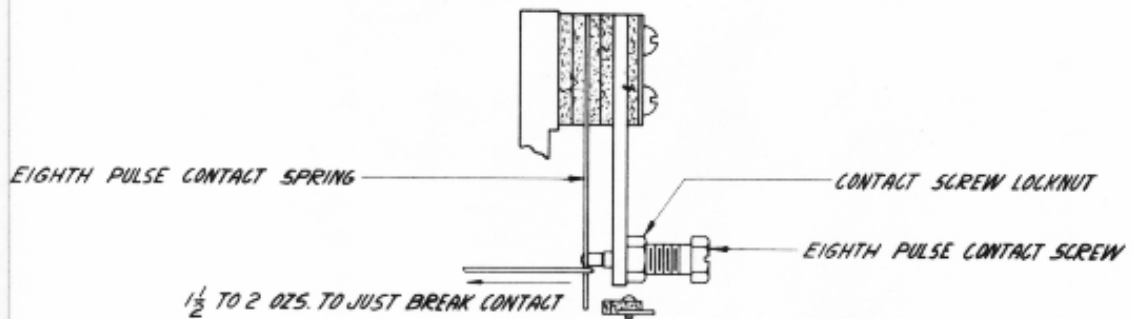

FIGURE 17

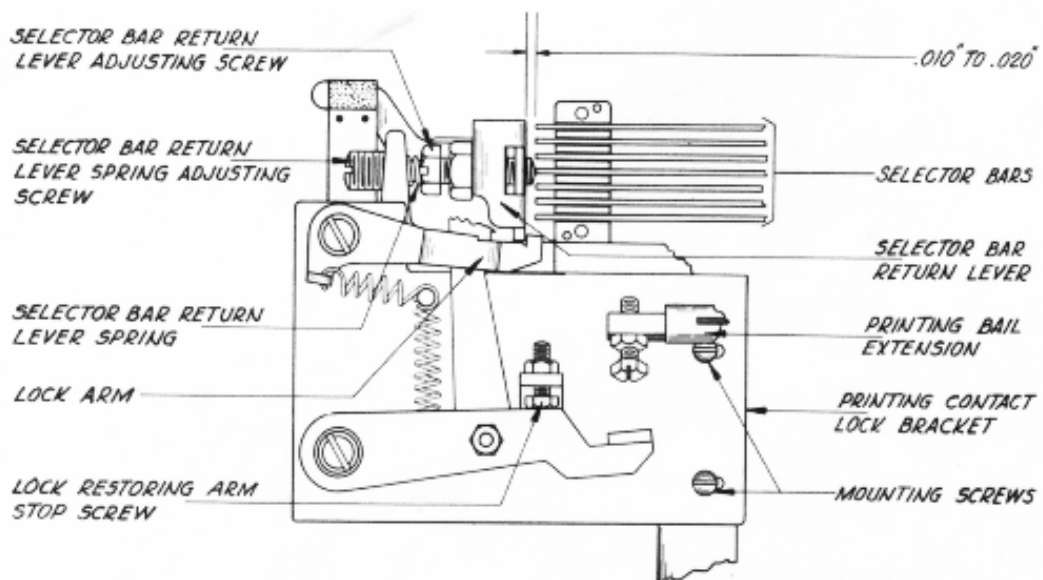

FIGURE 18

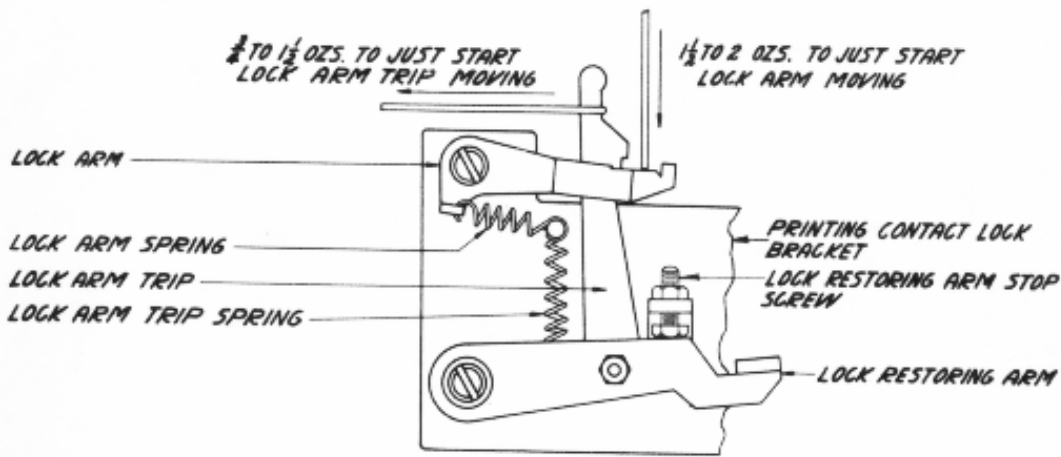

FIGURE 19

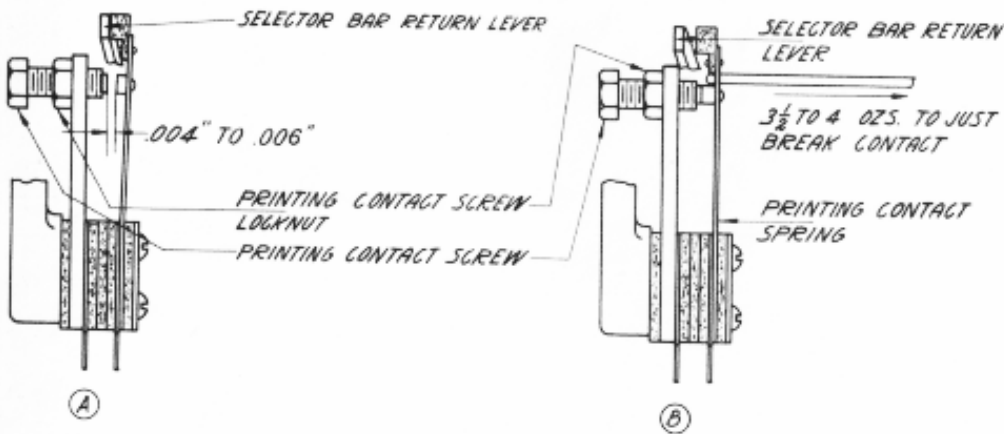

FIGURE 20

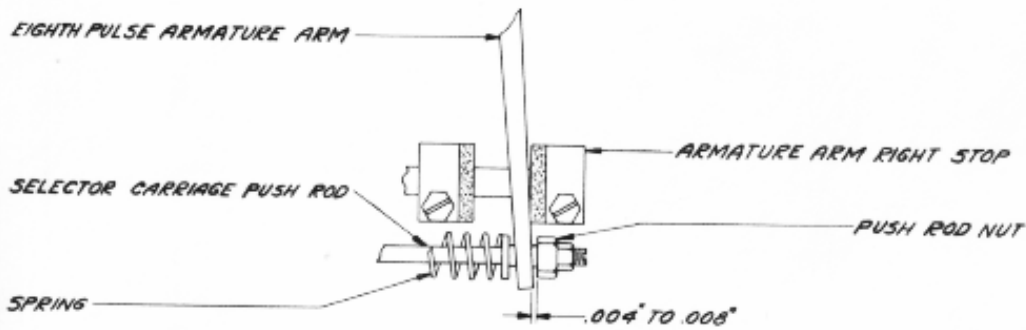

FIGURE 21



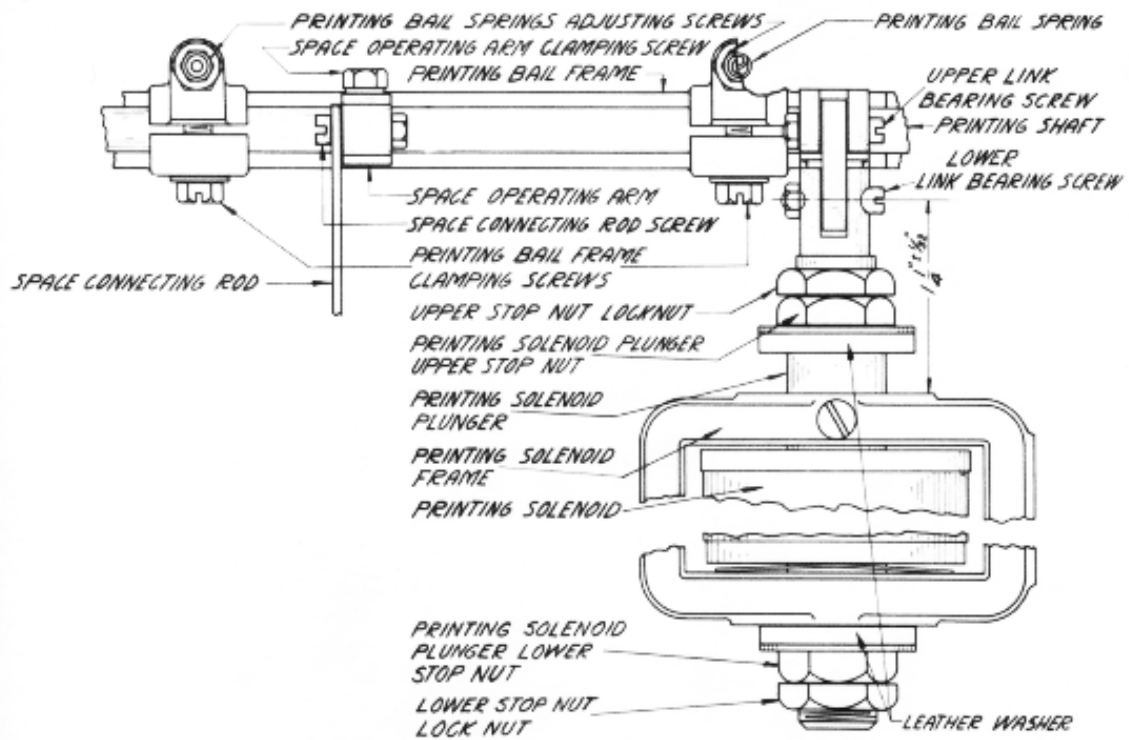

FIGURE 22

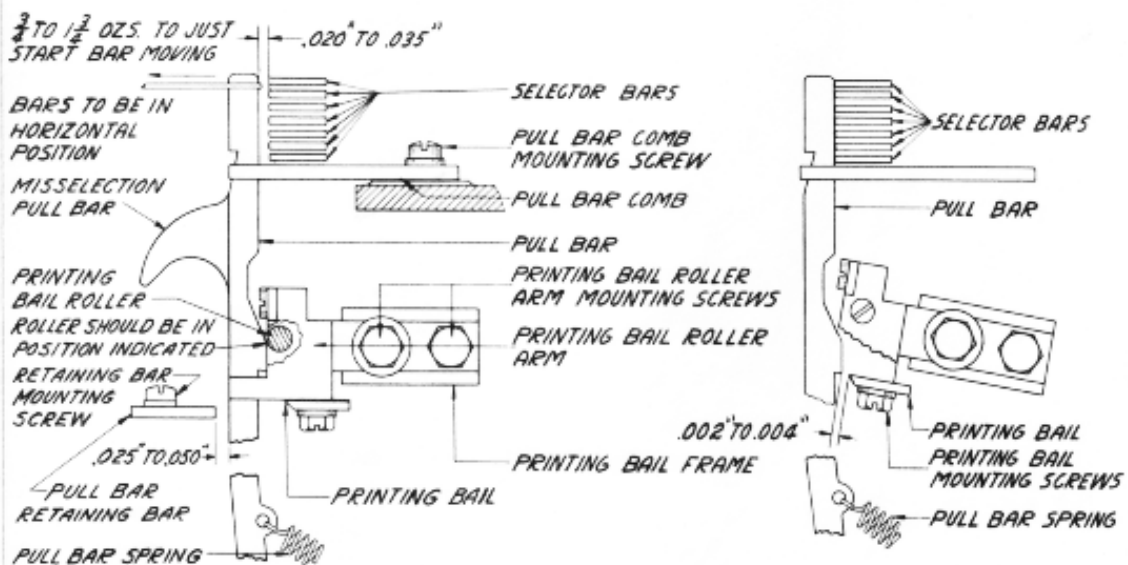

FIGURE 23

FIGURE 24

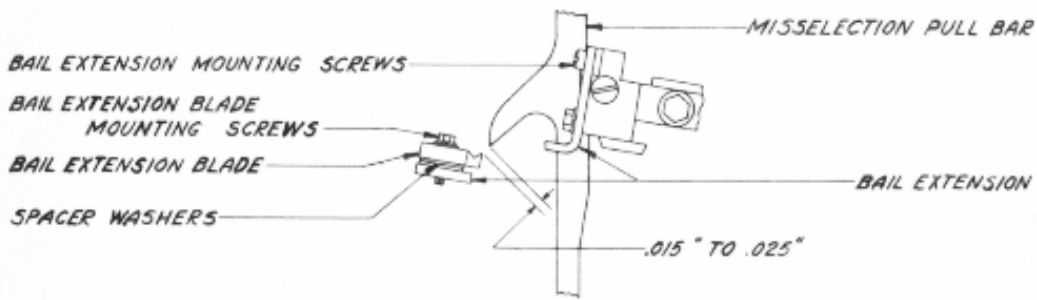

FIGURE 25

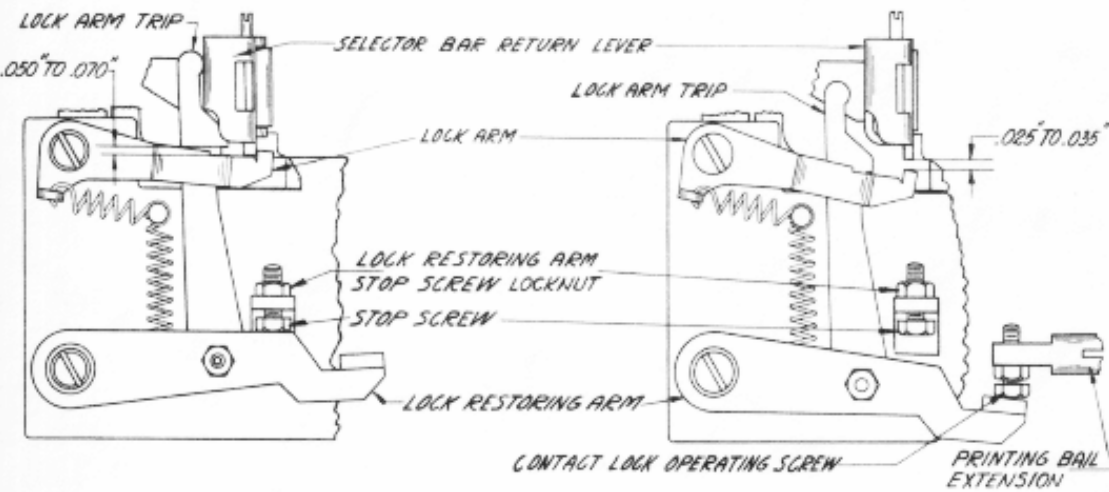

FIGURE 26

FIGURE 27

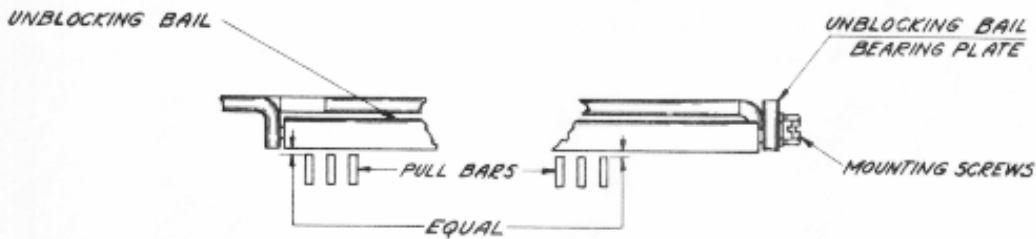

FIGURE 28

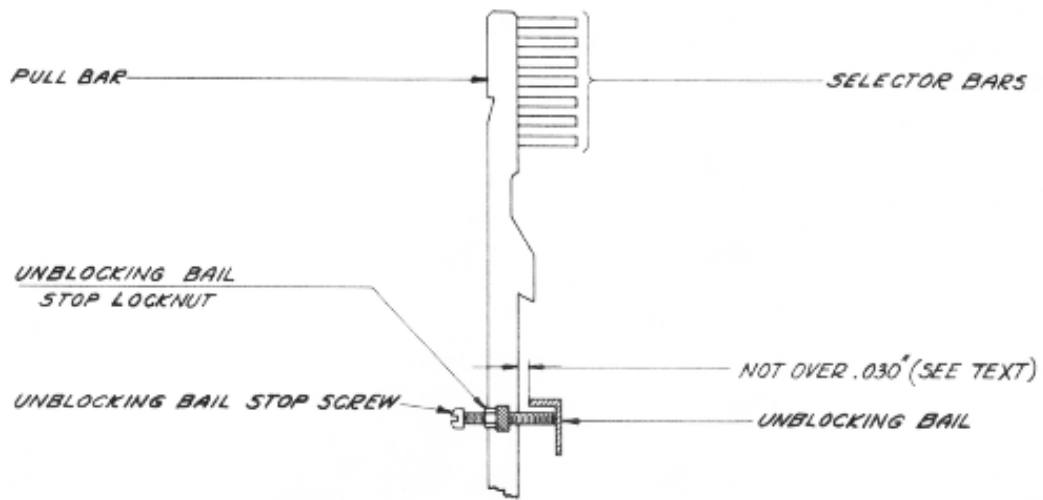

FIGURE 29

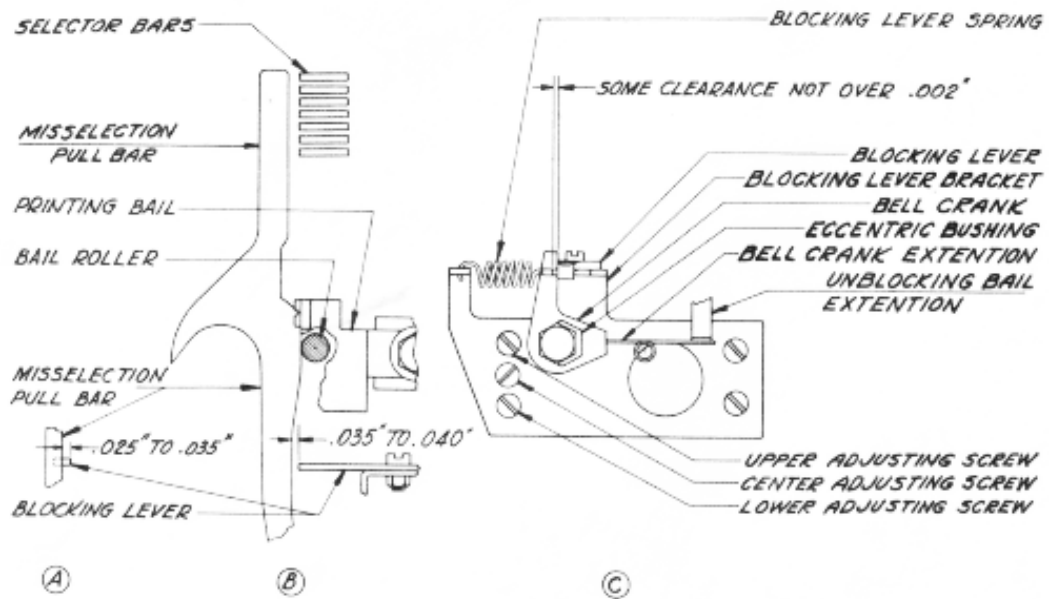

FIGURE 30

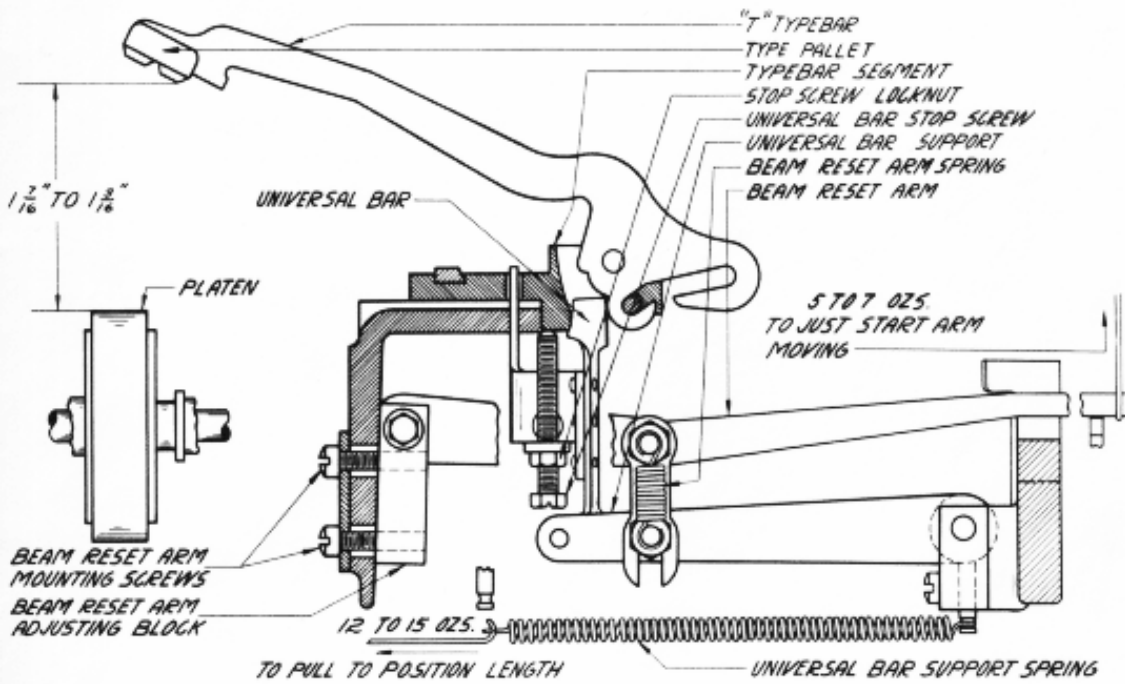

FIGURE 31

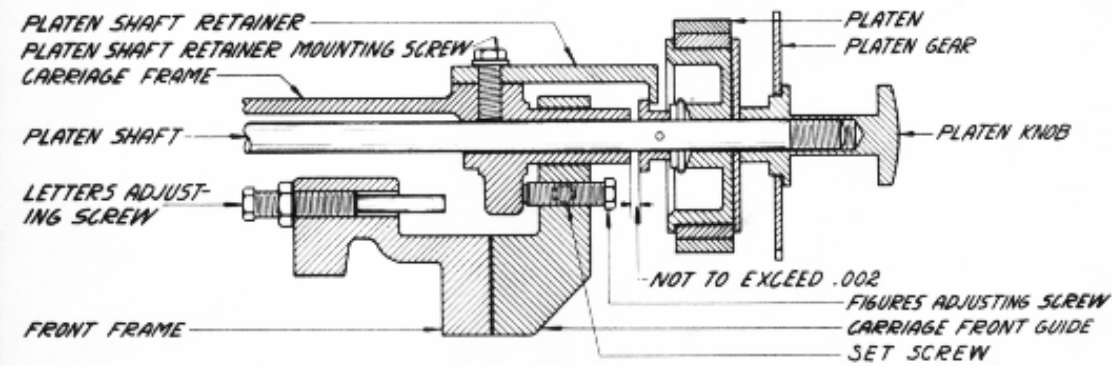

FIGURE 32

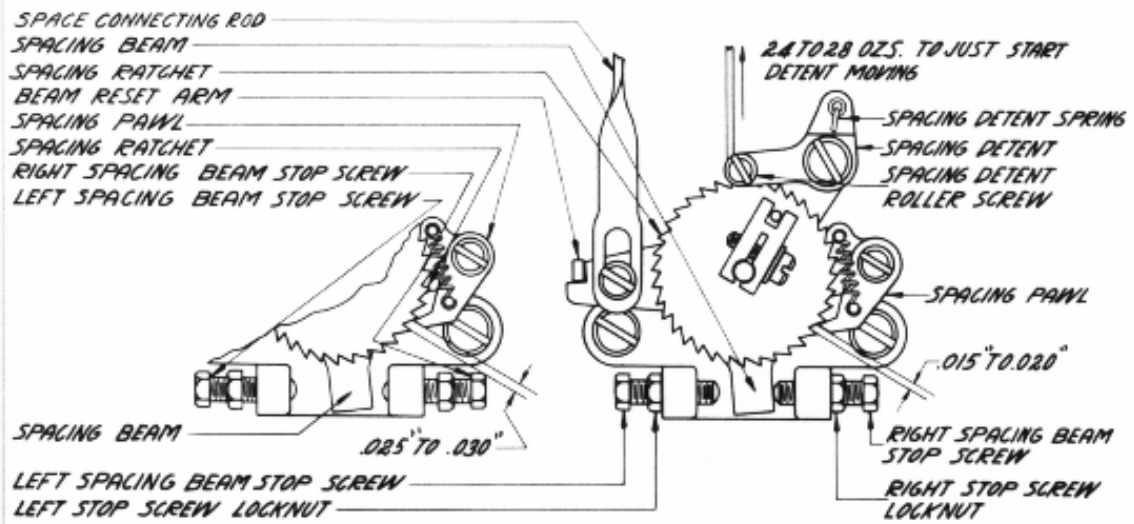

FIGURE 33

FIGURE 34

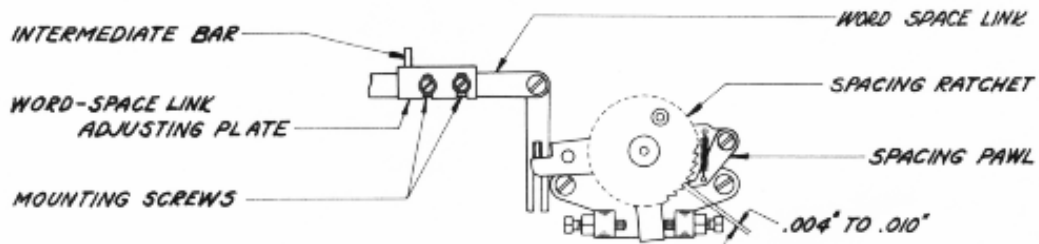

FIGURE 35

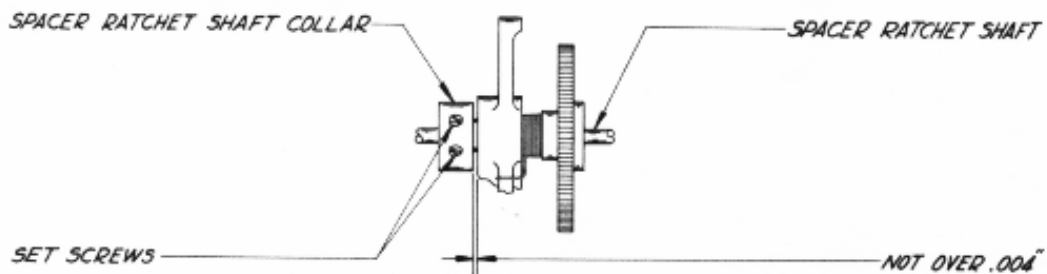

FIGURE 36

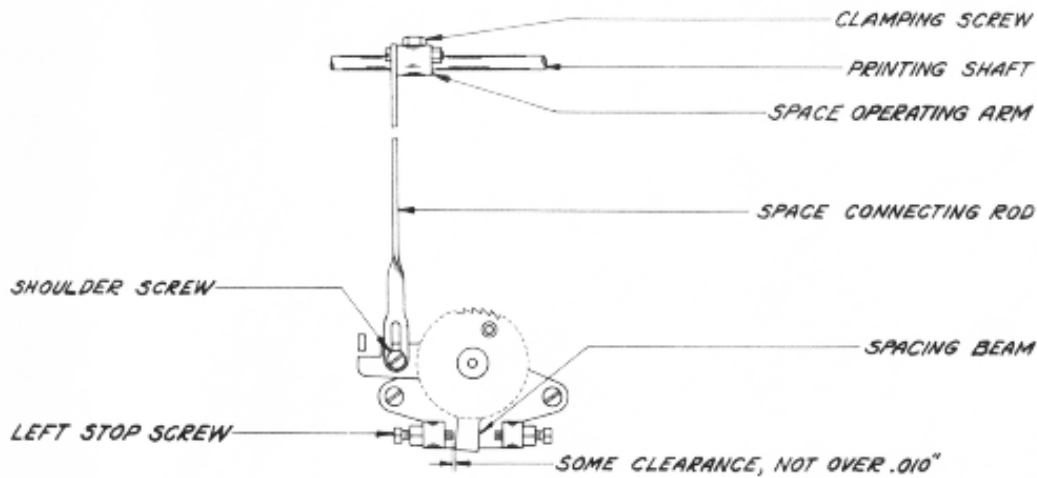

FIGURE 37

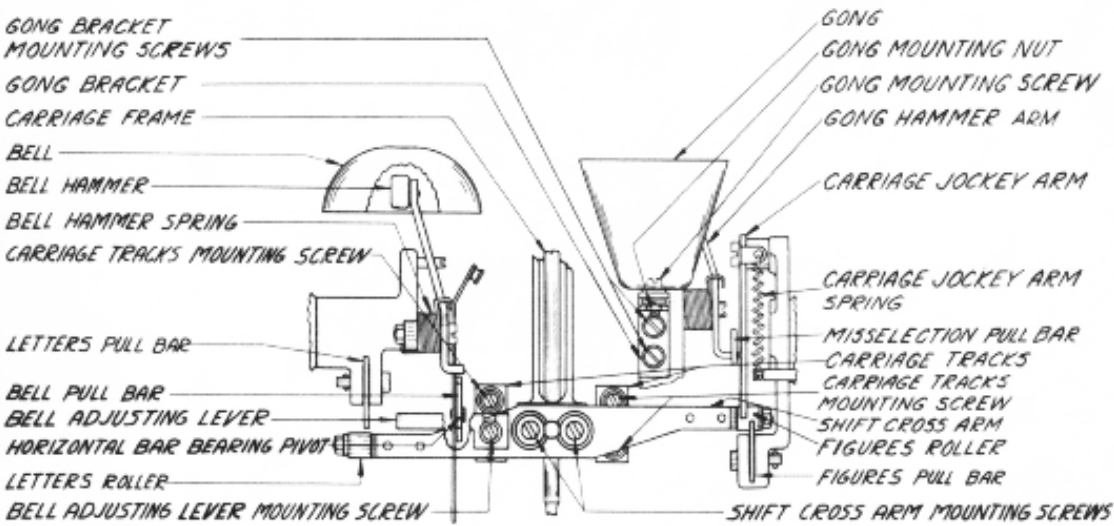

FIGURE 38

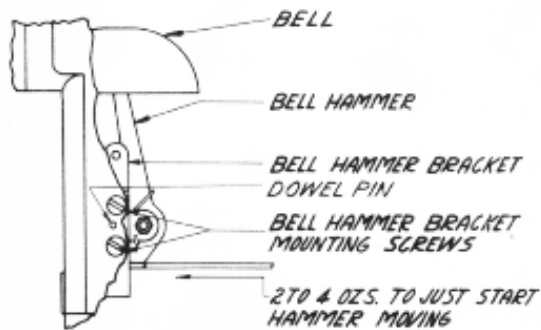

FIGURE 39

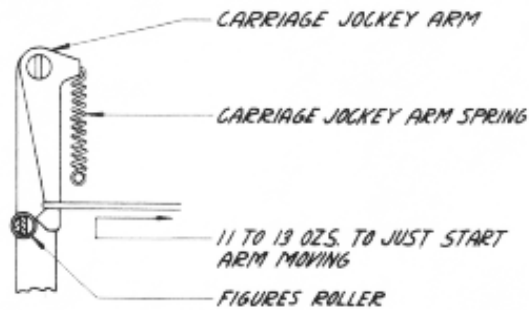

FIGURE 40

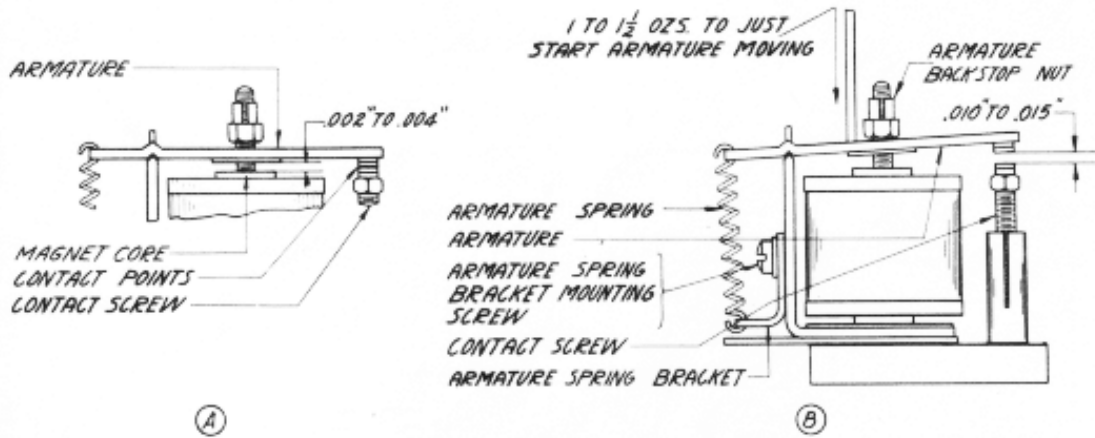

FIGURE 41

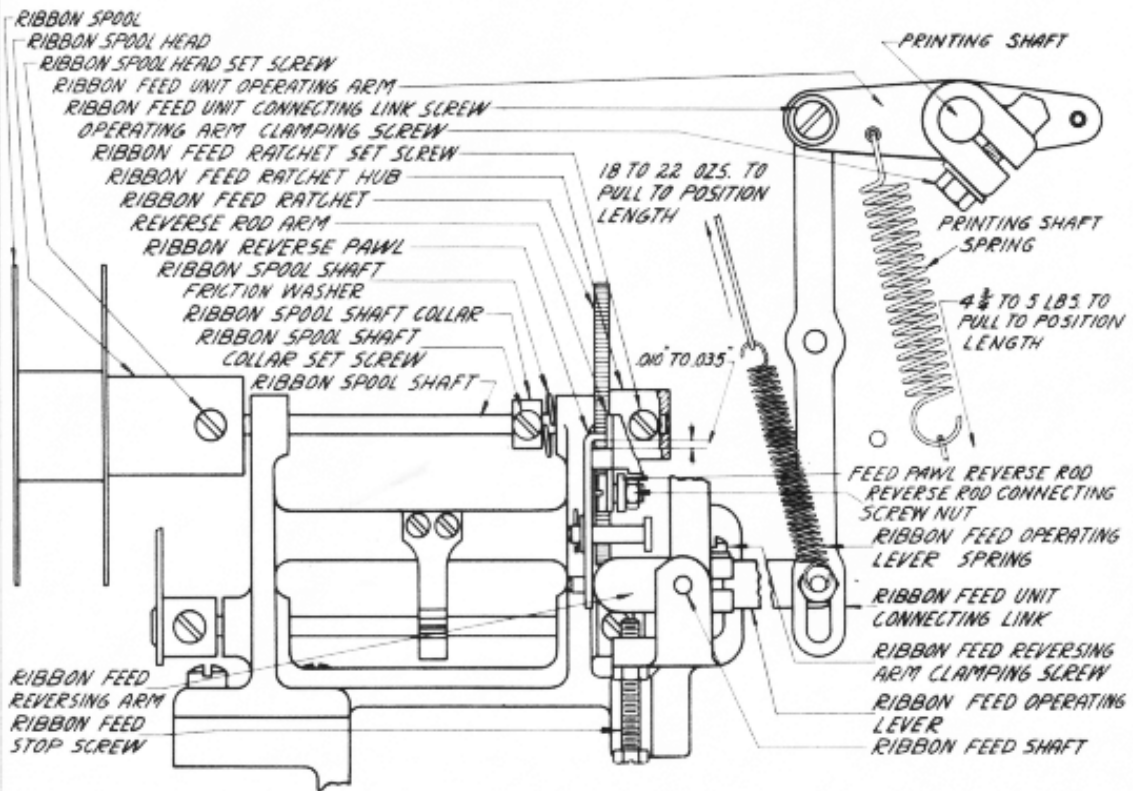

FIGURE 42

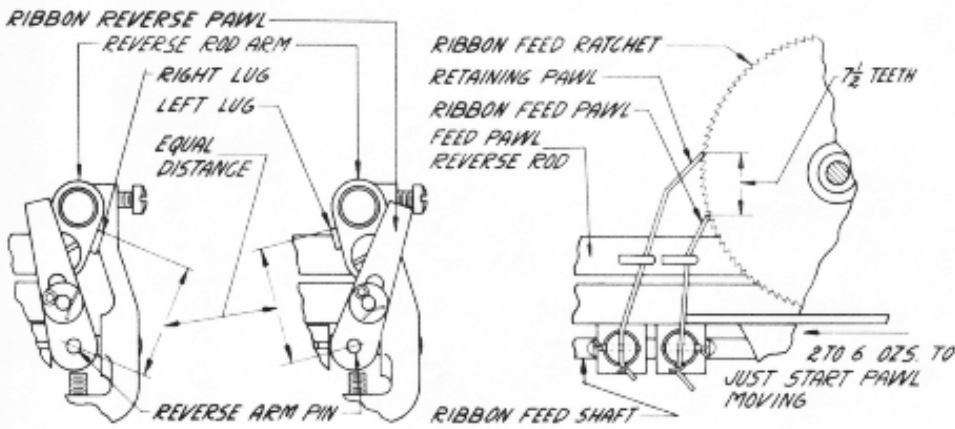

FIGURE 43

FIGURE 44

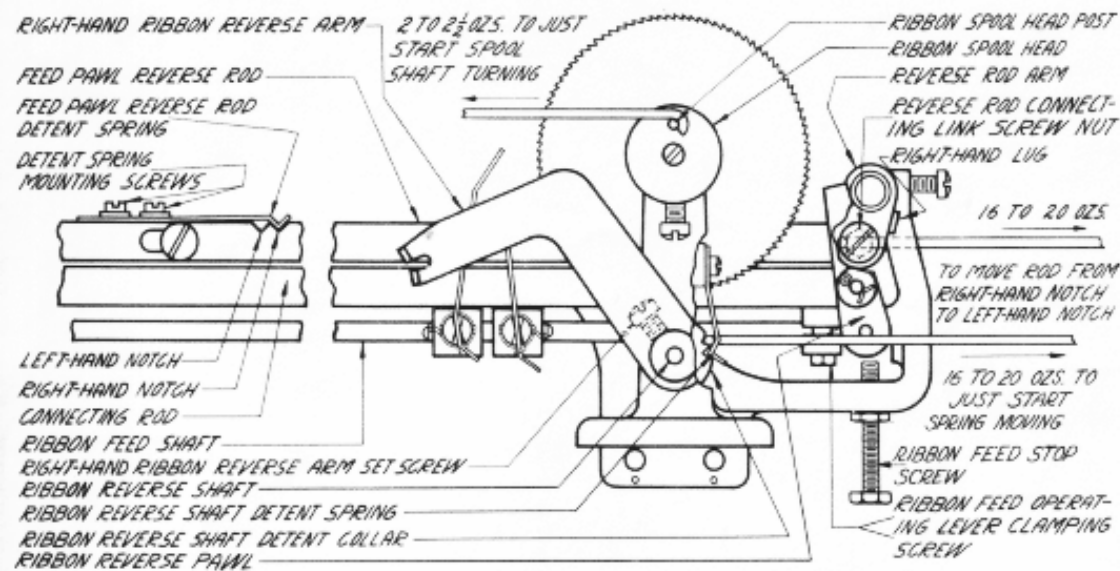

FIGURE 45

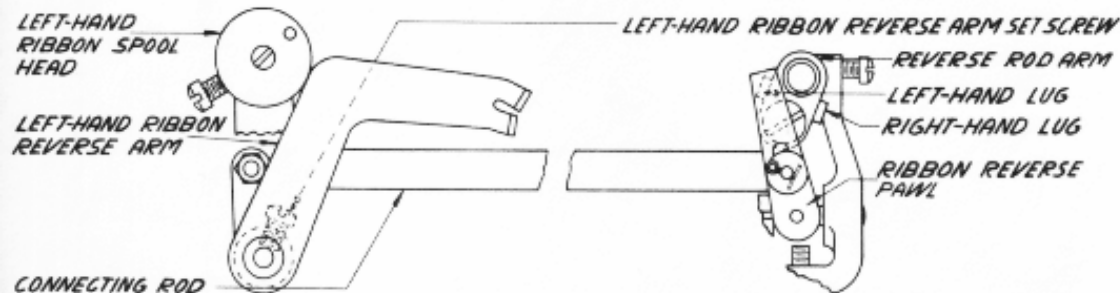

FIGURE 46



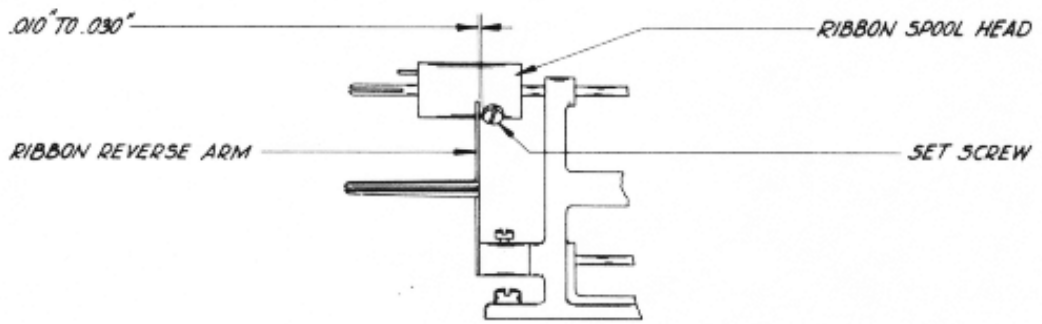

FIGURE 47

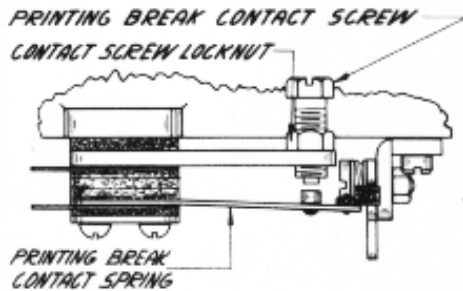

FIGURE 48

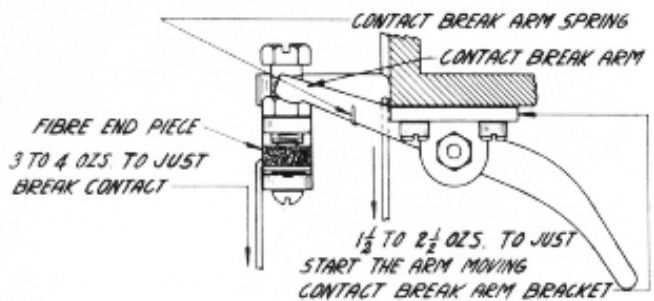

FIGURE 49

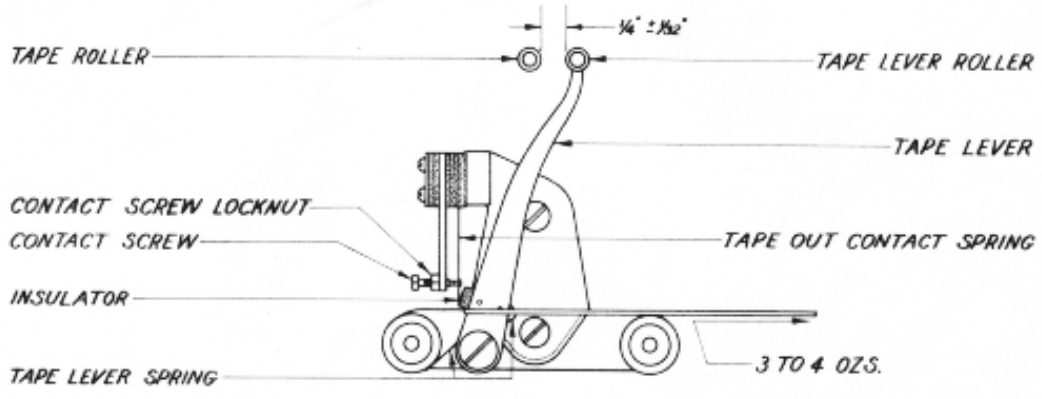

FIGURE 50