

TELETYPE MODEL 40 "OUTBURST" AMPS TERMINAL  
USER'S MANUAL

Copyright 1977 by Teletype Corporation  
5555 Touhy Avenue  
Skokie, Illinois 60076

All rights reserved.

Printed in U.S.A.

For further information, please contact:  
Mr. L. G. Schear, Teletype Corporation, 312-982-3594

## 1. ABOUT THE TELETYPE MODEL 40 "OUTBURST" SYSTEM

The Teletype Model 40 "OUTBURST" System Terminal provides facilities for preparing, storing, editing, printing, and automatically distributing messages within a large closed group of users. Each work position (maximum of 2 per terminal) consists of a CRT display screen, an operator console (keyboard), a printer, and magnetic tape cassette drives for the storage of messages, as well as some associated electronics to enable the interconnection of these components with other terminals in the system. Messages may be prepared by any user of the system, and the system will automatically and rapidly deliver them to whichever other users are desired. A terminal can normally receive messages as long as it is turned on, even if it is otherwise being used, and it will return a message to the sender confirming the delivery. If, for some reason, either the user-originated message or the confirmation-of-delivery message were not immediately delivered, the originating terminal would continue to attempt the message delivery, either until it was successful, or until the sender interrupted it, or until it had completed a pre-determined number of attempts. The sender has continuously updated status information available, thus giving the message communication system a high degree of reliability.

A message must be sent to a terminal, not to a work position. The destination terminal will inform the operator at work position 1 that a message has been received and can be read on the display screen and/or printed as a hard copy. The work positions are identical in all other respects. A response to a message may, of course, be sent to the originator from either work position, as well as to any other interested users - each message sent has its own distribution list, which is created for it either specifically or by referring to one of a number of distribution lists which may have been previously defined.

The terminal in the AMPS area is equipped with a special printer to produce messages in the OCR/A character font for eventual entry into the AMPS system via a suitable optical character reader. This printer is the only unique feature of the AMPS terminal when it is compared to a standard "OUTBURST" terminal.

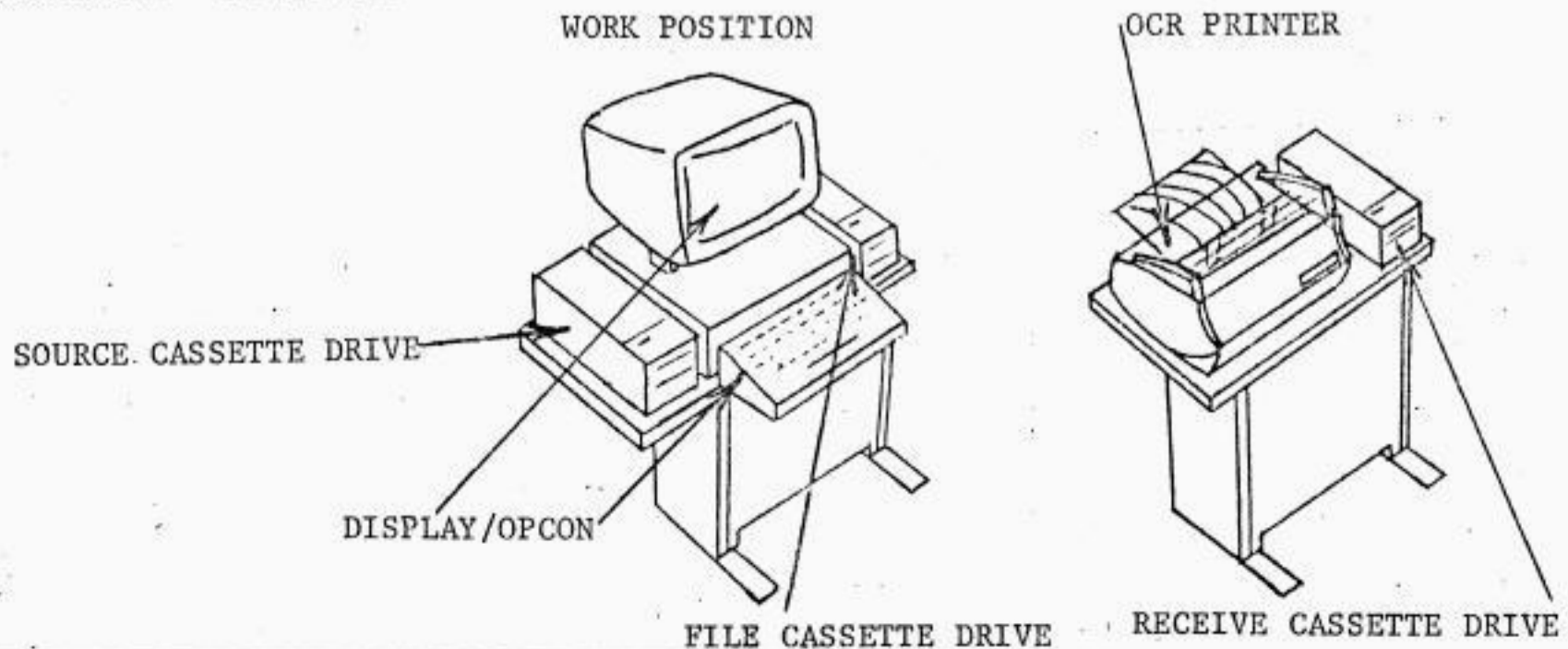

## 2. TURNING ON POWER

At a given location, a Teletype Model 40 "OUTBURST" System terminal consists of several pedestals, cabinets, and devices (displays, cassette drives, printer), each having a power switch.

PEDESTAL

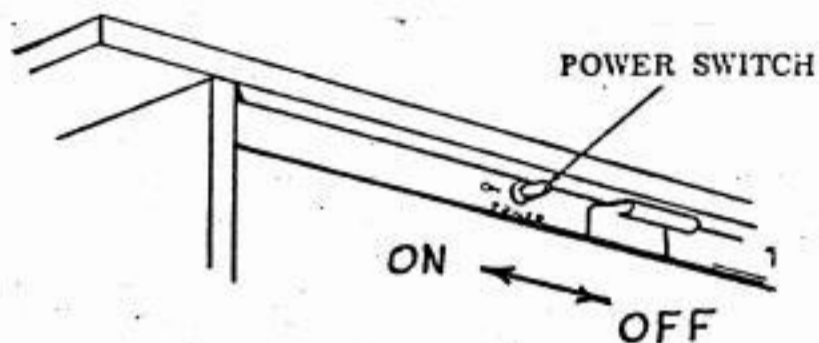

The pedestal power switch turns on power to any connected device. Individual devices may have their own power switches which must be turned on before use.

CABINET

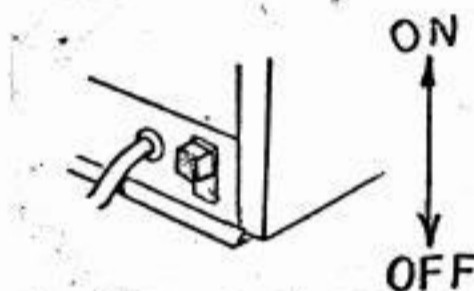

This switch, located on the left rear of the cabinet under the display, is the only control on the outside of the cabinet.

DISPLAY

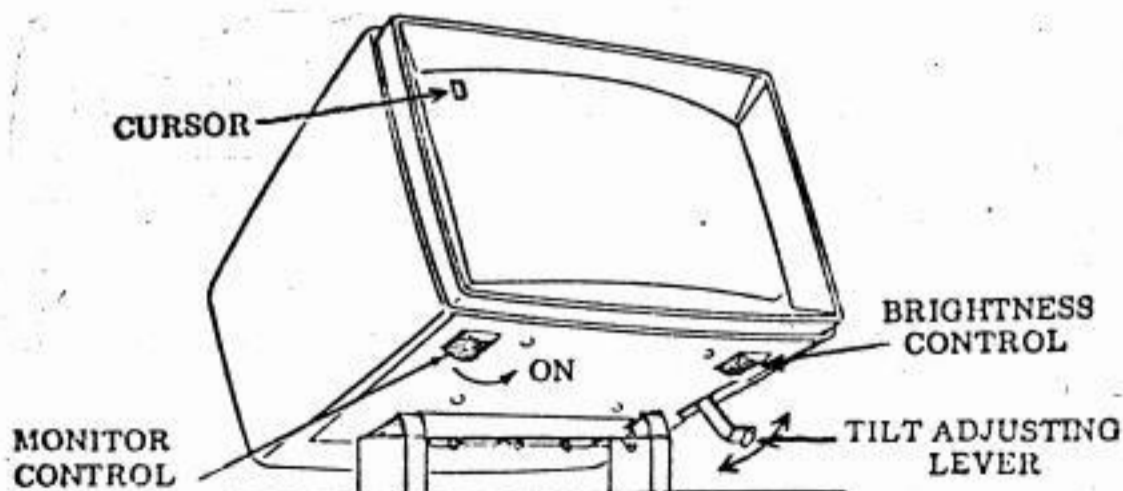

When the Monitor Control is rotated counter-clockwise, provided that power to the associated pedestal and cabinet is on, the cursor should appear after a short delay. Turn up the Brightness control (counter-clockwise) if not visible.

NOTE: The cursor is a lighted rectangular area on the screen that indicates where the next character will be displayed or where the next function will take place.

Should there be some glare reflected on the viewing surface of the display, a Screen Tilt control is provided. Move the adjusting lever to the right to disengage, and move it forward or backward to the desired position. Release lever to lock in place. Adjust Brightness and Screen Tilt for comfortable viewing.

When not in use, Brightness may be turned down and the Monitor Control may be turned off without loss of data on system display.

#### CASSETTE DRIVE

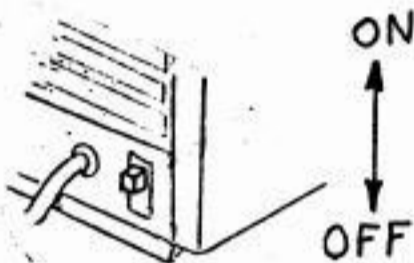

This switch, located on the left rear, is the only control on the outside of each cassette drive.

#### PRINTER

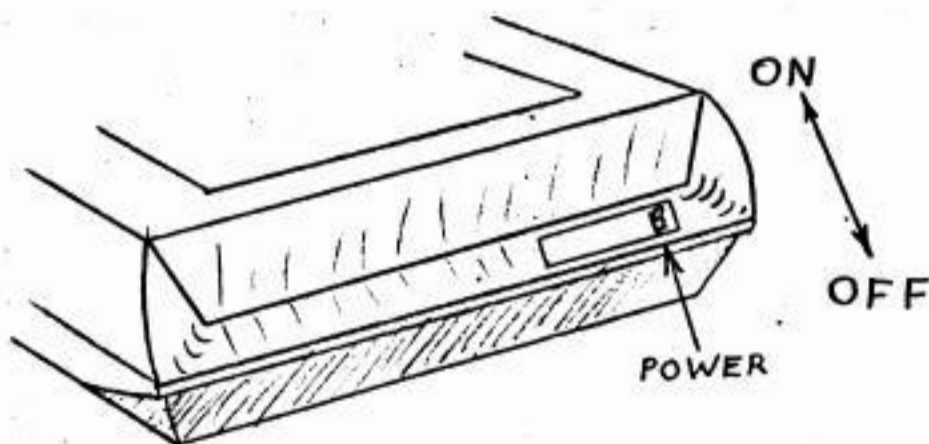

This switch is located on the right side of the exterior control panel of the Diablo HyTerm Model 1610 OCR/A printer.

When all power has been supplied to the terminal, it should be allowed to warm up for 30 seconds before proceeding. If pre-defined Interest Group distribution lists are not to be used, or are unavailable, skip the remainder of this paragraph; otherwise, insert the Interest Group cassette into the SOURCE cassette drive, located on the left side of the operator console and display of work position 1 (See Section 8 for cassette and cassette drive handling and operation). The red warning light on the SOURCE cassette drive will then be lit, indicating that the predefined Interest Group distribution lists are being loaded into the terminal. The cassette will then rewind and the red warning light will go out, indicating that the Interest Group cassette may be removed from the SOURCE cassette drive (See Section 8).

Insert the Terminal Program cassette into the SOURCE cassette drive, located on the left side of the operator console and display of work position 1 (see Section 8 for cassette and cassette drive handling and operation). The red warning light on the SOURCE cassette drive will then be lit, indicating that the program is loading. When this is completed, the index format for the three cassette drives associated with work position 1 will be presented on the display (if the power is turned on at work position 2, the index format will be displayed for the two cassette drives associated with it) and the INDEX key(s) will light.

The Terminal Program cassette will then automatically rewind and be examined and its presence will be noted in the SOURCE cassette index as a protected cassette named "????". The red warning light will go out and the cassette may then be removed (see Section 8).

**NOTE:** If the Terminal Program cassette does not load as described above, turn off all terminal power and repeat the power-on procedure after a wait of at least 15 seconds. Two sequential load failures indicate difficulty with either the Terminal Program cassette, the SOURCE cassette drive, or the terminal (see Section 12).

3. OPERATOR CONSOLE (KEYBOARD)

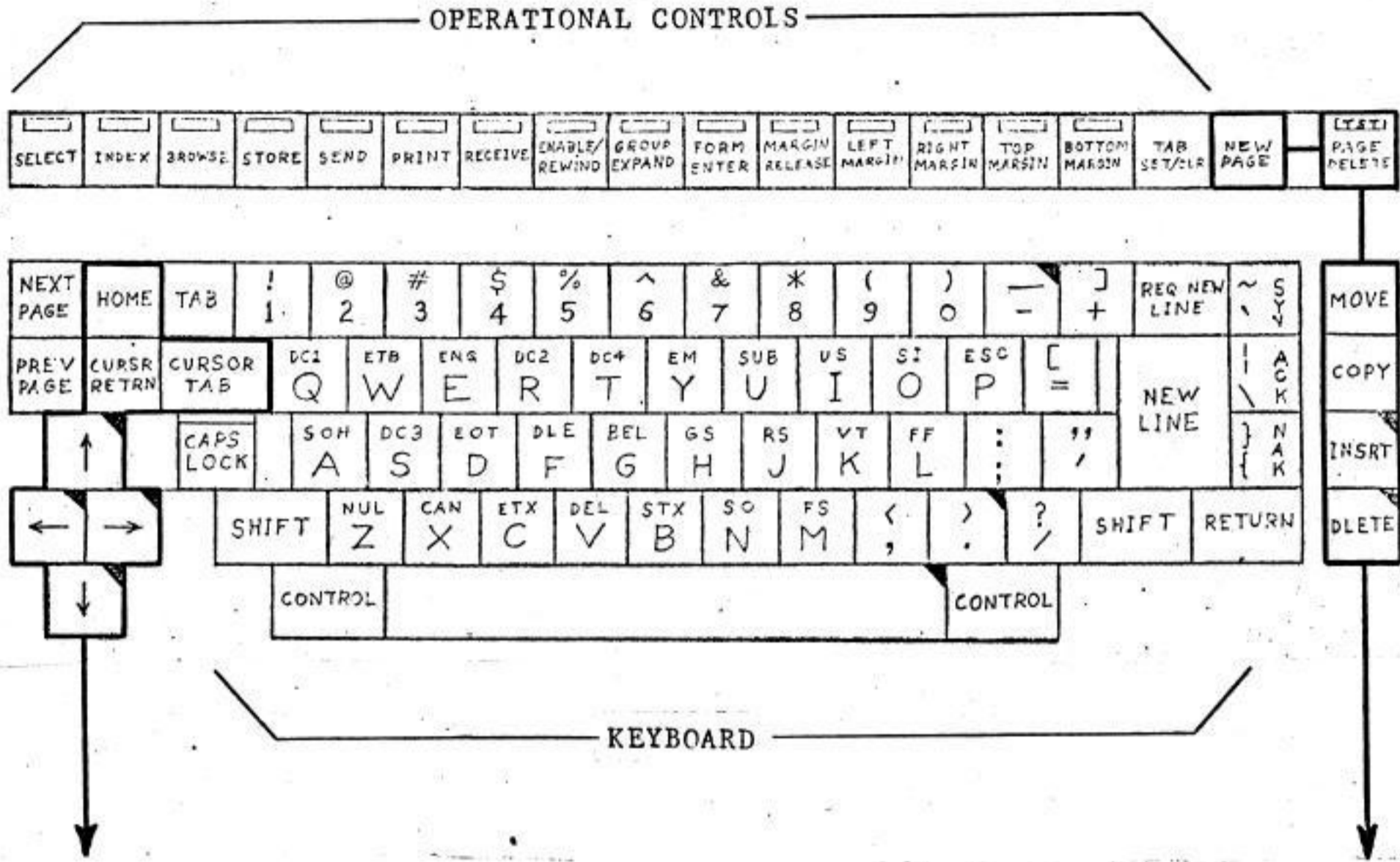

LEFT-HAND EDITING CONTROLS  
 (Used to position the cursor  
 without modifying information  
 on the display)

RIGHT-HAND EDITING CONTROLS  
 (Used to modify information  
 on the display)

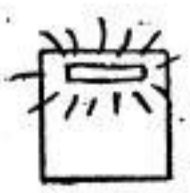

Key lights, indicating mode of operation.

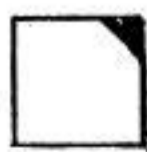

Keys repeats when pushed to bottom (repeat zone).

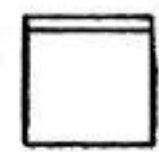

Push-push locking key

OPERATOR CONSOLE (KEYBOARD)

Pushing a key generates the corresponding character or performs the function on the display, as indicated.

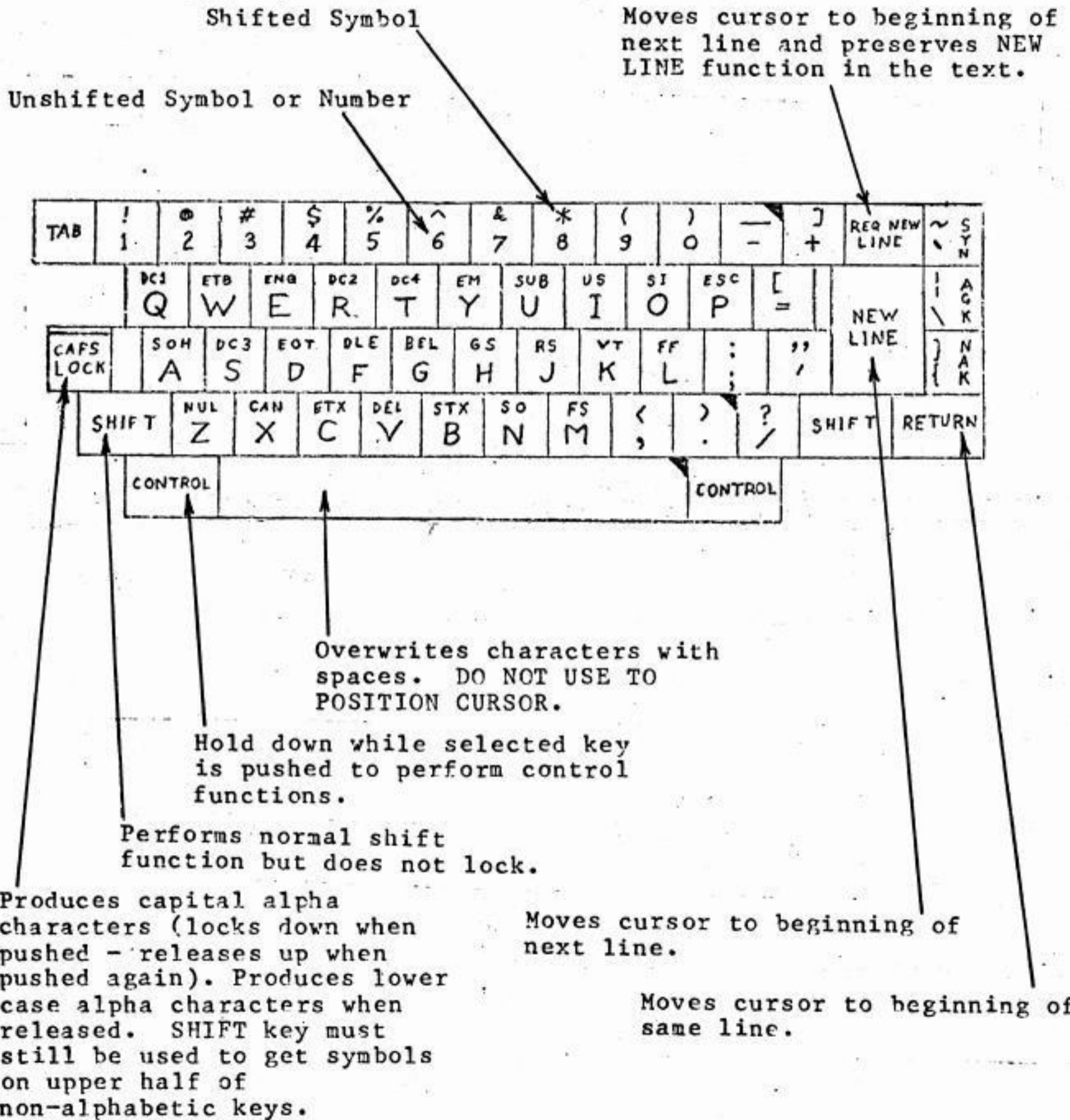

Key repeats when pushed to bottom (repeat zone).

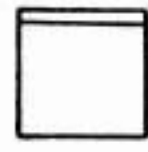

Push-push locking key.

LEFT-HAND EDITING CONTROLS

NOTE: These keys position cursor without altering data on the screen.



Positions cursor toward the upper left-hand corner of the screen.



Cursor Return - Moves cursor to the first position on the same line, as determined by the left margin.

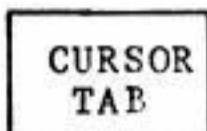

Moves cursor to next tab stop or to beginning of next line if there are no more tab stops on current line.

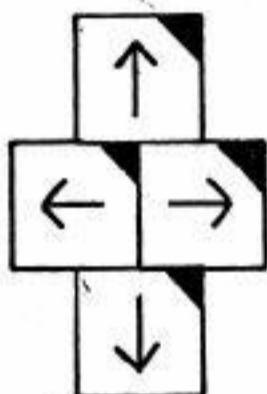

These up, down, left, and right cursor positioning keys move the cursor in the direction indicated by the arrow.



Key repeats when pushed to the bottom (repeat zone).



RIGHT-HAND EDITING CONTROLS

Delete - This key causes the CHARACTER at the cursor location to be deleted from the display and the rest of the text on that line to be shifted one space to the left, filling the space previously occupied by the deleted character. The cursor does not move.

If neither line margin is set, or if only one (left or right) is set, or if the MARGIN RELEASE key is lit, the delete operation will end when the last character on the line has been deleted.

If both the left and right margins are set, and the MARGIN RELEASE key is not lit, full WORDS will be wrapped upward from successive lines into the cursor line, as space becomes available. A similar operation takes place on all successive lines within the paragraph (a new paragraph is defined as text preceded by a blank line, or by a REQUIRED NEW LINE, or with an indentation from the left margin). If the DELETE key is held in the repeat zone, and the last character of the current paragraph has been deleted, successive LINES of the following paragraph(s) will be deleted, one at a time, at a slower rate than continuous character deletion.

If the DELETE key is pushed when the cursor is positioned over a message entry in the cassette index, that message will be deleted from the index; message sequence numbers will not be altered.

The entire index of a cassette will be deleted if the cursor is positioned over the name of the cassette and the DELETE key is pushed.



Key repeats when pushed to the bottom (repeat zone).

MOVE

This key operates similarly to DELETE, except that the deleted characters, words, and lines are saved in the MOVE/COPY storage buffer for future use. This allows a section of text to be moved from one position to another within a message, or to another message.

COPY

This key operates similarly to MOVE, except that the characters, words, and lines are not deleted from the text; the character at the cursor location is saved in the MOVE/COPY storage buffer for future use and the cursor is automatically incremented and successive lines are automatically displayed, as required. This capability is especially useful for copying paragraphs and entire sections of text within the same message and between different messages.

INSRT

Insert - With the MOVE/COPY storage buffer empty, a single push of the INSRT key will move text starting at the cursor location one space to the right. The cursor does not move. If the key is pushed to the bottom (repeat zone), the text will move through successive spaces to the right, with words wrapping around to the beginning of the next line if both left and right margins are set; otherwise, the existing text will move until it meets the right side of the display. No text will be lost.

If the INSRT key is held in the repeat zone with margins set, after the insert line is cleared of text, entire lines will be moved down. When the key is released, new text may be entered into the space created, starting at the cursor position.

If the MOVE/COPY storage buffer has some text in it, the text can be inserted into the message with the INSRT key. This will take place in a last-in-first-out order, and this insertion can be stopped at any time by merely releasing the key. Instead of spaces being inserted at the cursor location, the text from the MOVE/COPY buffer is inserted, with successive lines being moved down, a line at a time.

If an entire message is in the MOVE/COPY storage buffer, it can be stored on a cassette by positioning the cursor over an available entry in the cassette drive index and pressing the INSRT key. A new message number is assigned to the inserted message.



Key repeats when pushed to the bottom (repeat zone).

TELETYPE MODEL 40 "OUTBURST" AMPS TERMINAL

TABLE OF CONTENTS

<u>SECTION</u>	<u>TITLE</u>	<u>PAGE</u>
1.	About the Teletype Model 40 "Outburst" System . . . . .	1
2.	Turning On Power . . . . .	2
3.	Operator Console (Keyboard). . . . .	5
4.	Preparing and Editing Messages . . . . .	13
5.	Sending Messages . . . . .	21
6.	Printing Messages. . . . .	22
7.	Turning Off Power. . . . .	23
8.	Cassette Drive Operation . . . . .	24
9.	Printer Operation. . . . .	26
10.	Terminal Maintenance . . . . .	28
11.	Paper and Ribbon Replacement . . . . .	32
12.	When Trouble Occurs. . . . .	35

NEW  
PAGE

Text in the "OUTBURST" system is partitioned into "pages" of text of up to 66 lines per page. The NEW PAGE key is used to make room to allow a large amount of text to be inserted into a message being edited, to end the current page before the bottom margin is reached, or to add a page at the end of a message being edited. Note that the new or inserted page will follow the currently displayed page.

TST  
PAGE  
DELETE

The complete currently displayed page of text of a message being edited can be deleted at one time with the PAGE DELETE key. This must be done, however, before the page is written onto the FILE cassette (that is, before the NEXT PAGE key is pushed). The beginning of the next page of text, if any, will then appear on the display. The small TST light is used when checking the operation of the operator console, as described in Section 12. (This key is also used to initialize a cassette, as described in Section 8.)

OPERATIONAL CONTROLS

NOTE: For an explanation of how these controls are used, see Section 4.



The SELECT key is used to select a cassette index for display, to select a message from that cassette for reading, editing or some other operation, to de-select the current message, and to display a cassette index after reading or editing a message. The light indicates that part of a message is displayed.



The light in the INDEX key is lit when power is first applied to the work position and when a cassette index is displayed. Pushing this key has no effect.



The BROWSE key is used for continuous entry, reading, or editing of messages; after all operations are concluded with one message on a cassette, the next message is automatically accessed for similar operation, or, in the case of new message preparation, a blank message header will be automatically displayed.



The STORE key is used to store the displayed message on the FILE cassette drive.



The SEND key is used to send the displayed message to the users specified on the distribution list.



The PRINT key is used to send the displayed message to the printer.

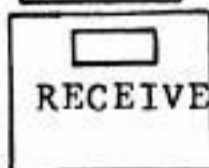

The light in the RECEIVE key is used to signal the operator of work position 1 that a high-priority message has arrived on the RECEIVE cassette drive. Pushing this key has no effect at the work position.



The ENABLE/REWIND key is used to enable the selected cassette drive for storing and retrieving messages and also to rewind the selected tape cassette before removing it from the cassette drive.



The GROUP EXPAND key is used to display or modify one or more pre-defined lists of users in order to create a distribution list for a message.

FORM  
ENTER

The FORM ENTER key is used to create or edit "protected" or "fixed" fields or sections of text which may not normally be affected by the various editing functions. This text may only be entered or changed when the key is lit.

MARGIN  
RELEASE

The MARGIN RELEASE key is used when it is desired to move the cursor, either for the purpose of entering text or changing margins, beyond the limits set by the current margins. The key is lit when the cursor is beyond current margins. The function resets when the cursor returns within current margins or when a margin is changed to the cursor position.

LEFT  
MARGIN

The LEFT MARGIN key is used to set the left margin to the character position (column) currently occupied by the cursor. It determines the beginning of the line.

RIGHT  
MARGIN

The RIGHT MARGIN key is used to set the right margin to the character position (column) currently occupied by the cursor. It determines the length of the line and will change to keep the line length constant when the left margin is changed.

TOP  
MARGIN

The TOP MARGIN key is used to position the first line of text on a page (of up to 66 lines) to the line currently occupied by the cursor.

BOTTOM  
MARGIN

The BOTTOM MARGIN key is used to position the last line of text on a page (of up to 66 lines to the line currently occupied by the cursor).

TAB  
SET/CLR

The TAB SET/CLR key is used to set or clear the tabulator stop in the column currently occupied by the cursor.

NEXT  
PAGE

The NEXT PAGE key is used to display the next page of a message, if one exists.

PREV  
PAGE

The PREV PAGE key is used to display the previous page of a message, if one exists.

The audible alarm ("bell") may sound ("ring") in two places on a line of text - at the end of a line, as determined by the right margin or column 80, and at the ninth character position before it. It will also sound when either the index or message header format is displayed if the operator tries to enter characters anywhere but in the designated areas.

#### 4. PREPARING AND EDITING MESSAGES

The "OUTBURST" terminal has the capabilities of message preparation, automatic multi-message storage and retrieval, editing, printing, and automatic distribution with indication of transmission status and verification of editing.

Messages are partitioned into pages of up to 66 lines, so that each may be printed on a single sheet of paper. Previous pages of the currently selected message may be recalled to the display, as well as the next pages of existing messages.

The user can input text from the operator console or from cassettes and present it on the display. The displayed text may be edited, stored on a cassette, printed, or sent to other users.

Two cassette drives are used for offline storage, automatically supplying text to the display and storing it from the display. The SOURCE cassette (in the SOURCE cassette drive) is used as a supplier of messages to be edited and the FILE cassette (in the FILE cassette drive) is used to record newly prepared or edited messages. Before the terminal memory is full, data will automatically be transferred to the FILE cassette to allow room for additional data. If an entirely new message is being created, this data will be entered from the operator console; otherwise, it will automatically be transferred from the SOURCE cassette. Incoming messages to the terminal are automatically stored on the RECEIVE cassette (in the Receive cassette drive), which is only accessible from work position 1; optionally, the Receive cassette may be read in any cassette drive of either work position.

CASSETTE TAPE INDEX

When a cassette is placed in a cassette drive, its identification and use status are displayed above the terminal index.

SOURCE CASSETTE: TEST  
 UNUSED BLOCKS: 293  
 MESSAGES: 0  
 PROTECTED: NO

FILE CASSETTE: NONE  
 UNUSED BLOCKS:  
 MESSAGES:  
 PROTECTED:

RECEIVE CASSETTE: NONE  
 UNUSED BLOCKS:  
 MESSAGES:  
 PROTECTED:

SOURCE INDEX	DESCRIPTION	P	DATE	JOBS
--------------	-------------	---	------	------

0. PREP

The SELECT key allows the operator to select either the SOURCE cassette, the FILE cassette, or the RECEIVE cassette for index display, depending upon the cursor position. Each push of the CURSOR TAB key will move the cursor to the next cassette label, with wraparound from the last to the first. The SELECT key will then display the index of messages for the cassette selected by the cursor. Each entry in the index consists of a message sequence number, description, priority, date of creation, and status (an "S" in this column indicates that the message is scheduled to be sent, and a "P" indicates that it is scheduled to be printed). The first entry, message 0, is a format used to aid the generation of new messages.

The ENABLE/REWIND key will enable the selected cassette drive and will underline "SOURCE CASSETTE", "FILE CASSETTE", or "RECEIVE CASSETTE" on the index display, indicating that messages may be read from (and possibly stored on) it. When a cassette drive is enabled, the name of the cassette currently loaded in it may not be changed; this may be done only when the cassette is rewound.

SOURCE CASSETTE: TEST  
 UNUSED BLOCKS: 293  
 MESSAGES: 0  
 PROTECTED: NO

FILE CASSETTE: NONE  
 UNUSED BLOCKS:  
 MESSAGES:  
 PROTECTED:

RECEIVE CASSETTE: NONE  
 UNUSED BLOCKS:  
 MESSAGES:  
 PROTECTED:

SOURCE INDEX	DESCRIPTION	P	DATE	JOBS
--------------	-------------	---	------	------

0. PREP



MESSAGE HEADER

Each message consists of two parts - the Message Header, which contains the message, its priority, date of creation, distribution list (intended destinations), and delivery status for each addressee, and the Message Text, which includes the information content of the message (main body of text, tables, etc.) and (optionally) the name of the originator and/or sender.

In order to select an existing message for editing, position the cursor over the number of the desired message with the cursor positioning keys (arrows), and push the SELECT key. The Message Header will then be displayed.

MESSAGE DESCRIPTION:

PRIORITY:

DATE:

SEND TO:

GRPTERMNAMEST

1.

2.

3.

4.

5.

6.

7.

8.

9.

10.

This presents the full identification and distribution status for this message. Up to 50 terminals may be specified as destinations for a single message. With the terminal number as part of the address, all users in a group or department may be addressed at once. A number of different terminals may be addressed at once by specifying one or more Interest Groups. The status information for each address shows whether or not the message has been sent and delivered, and the reason if it has not been corrected received.

Message Header Status Information

- "blanks" - No operation has been requested that will cause delivery to this destination or no delivery attempt has been completed.
- "DE" - (Delivered) The message has been sent and correctly delivered to this destination.
- "BA" - (Bad Address) A invalid destination has been detected for this destination.
- "RA" - (Repeated Address) A repeated destination has been detected (only one copy of a message need be sent to a terminal - multiple copies may be made locally).
- "T1" through "T6" - (Tried to deliver n times) "n" attempts have been made automatically to deliver the message. After 7 failures, the message is considered "Not Deliverable", and no further deliveries are attempted.
- "ND" - (Not Deliverable) The message can not be delivered to this destination.

MESSAGE TEXT

When the operator has finished examining or generating the distribution list for this message, using the up and down cursor positioning keys or the NEW LINE key to access entries before or after the ten currently displayed, the first page of the message itself can be viewed by pressing the NEXT PAGE key. The first page of the message will be displayed, with cursor and margin locations indicated.

MARGINS

Margins may be used to provide automatic boundaries for the text entered from the operator console. Left and right boundaries may be used to allow unstructured entry of text without concern for hyphens or broken words, and top and bottom margins may be used to define a page of text (maximum of 66 lines).

To set left and right margins, use the cursor positioning keys (arrows) to place the cursor in the appropriate column, as indicated by the column counter on the top line of the message format when the text of the message is displayed. Push either the LEFT MARGIN or the RIGHT MARGIN key. The new margin will be indicated by the margin indicator "l" (for "left") or "r" (for "right") in the row of dashes. If not set otherwise, the left and right margins are automatically set to column 11 and 70, respectively.

In order to set the left margin to the left of its current position, or to set the right margin to the right of its current position, the MARGIN RELEASE key must be used when positioning the cursor.

To set top and bottom margins, use the cursor positioning keys (arrows) to place the cursor on the appropriate line, as indicated by the line counter. Push either the TOP MARGIN or the BOTTOM MARGIN key. The new margin will be indicated on the top line of the message format. If you do not set them, the top and bottom margins are automatically set to lines 1 and 66, respectively.

The MARGIN RELEASE key may be used to ignore the margins without changing them. When pushed, it lights, indicating that all margins are released; when pushed again, the light goes off and the margins are set as before. Also, if the cursor returns within the margin boundaries, the MARGIN RELEASE function is ended and the light goes out. This key affects all four margins.

PAGE 11      LINE 2      COL 14      TOP 1      BOT 66

1  
-----  
THE CURSOR IS ON THE SECOND LINE OF THE 11 TH PAGE IN COLUMN  
#14

TABULATION

The TAB key may be used to move the cursor to the end of a protected field (area where characters from the operator console may not be entered) or to a tab stop. Spaces will fill the area skipped over when the message is printed. To rapidly reposition the cursor without inserting spaces, use the CURSOR TAB key. If either key is pressed and there is neither a tab stop nor a character position following a protected field on the current line, the cursor will move to the first print position on the next line (NEW LINE function) (except for the first line of the index format). Tab stops are indicated by a "T" in the row of dashes in the message header format and may be set or cleared with the TAB SET/CLR key. If no tab stops were set for that column when the key is pushed, one would be set; if one were set, it would be cleared. Tab stops are not permitted in the same columns as the left and right margins.

Tab stops may be individually set for each line of text; the last tab stops set on a page will be the ones set at the beginning of the next page.

After examining the distribution list for this message, the operator can display the first page of the message text by pressing the NEXT PAGE key (the Message Header is, effectively, page zero). Cursor, tab stop, and margin locations will be indicated.

```

                PAGE 11      LINE 2      COL 14      TOP 1      BOT 66
                T T          T          T          r
-----1----- THE CURSOR IS CN THE SECOND LINE OF THE 11 TH PAGE IN COLUMN
                #14□

```

Although there may be up to 66 lines per page, not all of them may be displayed at one time. There is enough room on the screen to display only 22 lines. Either the up or down cursor positioning keys may be pushed to the bottom (repeat zone), with the cursor at the top or bottom of the display, as appropriate, to scroll the text up or down on the display, and the entire page may be read (the line number of the cursor will always be indicated). Other pages may be examined by using the NEXT PAGE and the PREV PAGE keys. The right-hand editing keys may be used to modify the message and to add comments before printing it or sending it to another user.

MESSAGE DESTINATIONS

The Message Header for each message generated at or received by a terminal includes the intended destinations (or distribution list) for that message (a message received from another terminal would have its status indicated as blanks or "Tn" (tried to deliver n times) in the distribution list entry for the destination terminal). Each destination (maximum of 50) may be specified by an Interest Group (GRP), a terminal address or identification number (TERM), and/or a system user name (NAME). If an Interest Group is specified, its members may be displayed if the cursor is positioned on any letter of its name in the GRP column and the GROUP EXPAND key is pushed. The terminal number and name of each member of the group will be displayed on a separate line, and, at this point, the distribution list may be modified by adding or deleting individual destinations, including those that were specified as part of the Interest Group (using the cursor positioning keys and the DELETE key).

INTEREST GROUPS

The Interest Group provides a convenient means for addressing messages a group of users without specifying each member of the group individually. A number of different Interest Groups, as well as individual entries, may be combined to form the distribution list (of destinations) for a message; however, the total number of specified destinations must not exceed 50. If the same destination appears in 2 (or more) Interest Groups, it will count as 2 (or more) destinations; only after the message has been sent will the duplicate destination be identified in the Message Header as a Repeated Address ("RA") (in this case, the message will only be sent once).

When power is applied to a terminal, previously defined Interest Group distribution lists may be loaded, at the operator's option, prior to loading the Terminal Program (as described in Section 2). Once the Terminal Program has been loaded, any changes made to the Interest Groups will not be reflected when the terminal is turned off and later turned on again.

If a new Interest Group cassette is to be generated, or if changes are to be made to an existing one, the terminal power must first be turned off for at least 15 seconds (see Section 7), and then re-applied, as detailed in the first 2 pages of Section 2. Instead of loading the Terminal Program and/or Interest Group cassettes, the Interest Group Program cassette should be loaded (see Section 8 for cassette and cassette drive handling and operation) in the SOURCE cassette drive of work position 1. When the red warning light on the SOURCE cassette drive goes out, remove the Interest Group Program cassette from the cassette drive and insert the existing Interest Group cassette (if any) into the SOURCE cassette drive and insert a cassette with covered holes (see Section 8) into the FILE cassette drive. Follow the instructions on the display to create or modify the Interest Group(s).

The new Interest Group cassette will be in the FILE cassette drive. When the red warning light in that cassette drive goes out, remove the cassette, mark it accordingly, and expose the hole under the upper left orange plastic tab (see Section 8). Remove the old Interest Group cassette from the SOURCE cassette drive and cover the hole under the upper left orange tab (see Section 8) so that it may be used as a message cassette. Turn off terminal power and wait at least 15 seconds before turning it on again to load (the Interest Group cassette) and the Terminal Program cassette, (see Section 2).

## 5. SENDING MESSAGES

After the message (Message Header and Message Text) has been prepared and edited, it should be stored on the enabled FILE cassette, using the STORE key. This may be pressed when any page of the message and its Message Header are displayed. "STORE IN PROGRESS" will be displayed; then the terminal index will be displayed, and the FILE cassette drive should be selected with the CURSOR TAB and SELECT keys. Position the cursor on the line describing the message to be sent and push the SEND key.

### ALTERNATE MESSAGE SENDING METHODS

A message may be sent from any enabled cassette by selecting the message with the cursor on the cassette index and pushing the SEND key.

NOTE: If the message had been previously sent from this terminal, it would be necessary to change the status of the specified destinations to "blanks" (no action yet taken) before sending it again.

All the messages on a cassette may be sent by selecting the enabled cassette on the terminal index and pushing the SEND key. The above note applies.

A message may be sent from the display by pushing the SEND key when any page of the message is displayed. The light on the SEND key will light, and the work position will be "locked up" for about 20 seconds. The light in the SEND key will go out and the Message Header will be displayed, showing the delivery status for each addressee. Pushing the SEND key again will cause the attempted re-delivery of the message to all addressees with "Tn" (tried to deliver n times).

6. PRINTING MESSAGES

Messages may be printed from either the display or from a cassette. When the desired message is on the display, the operator may push the PRINT key; otherwise, either a single message on a cassette, or all the messages on a cassette may be selected, using the methods described in Section 5 for sending a message, and the operator may push the PRINT key. The messages will be printed in the order in which they were requested, or in the order in which they appear in the cassette index, and will include all the Message Header information.



## 7. TURNING OFF POWER

Although each device (display, cassette drive, printer) has its own power switch(es), it is normally not necessary to turn them off individually; each pedestal power switch controls power to those devices atop it, so only 3 switches need be used to turn off all power at a terminal (2 switches for a terminal with 1 work position). Before turning off a terminal, it is recommended that all cassettes be removed from the cassette drives, following the procedures specified in Section 8.

## 8. CASSETTE DRIVE OPERATION

Magnetic tape cassettes are used to file long and/or multiple messages which are handled by the terminal, and also to allow incoming messages to be received and outgoing messages to be sent without interrupting the user. Cassettes are handled by the cassette drives, designated as SOURCE, FILE, and RECEIVE. The SOURCE cassette drive is to the left of the operator console, the FILE cassette drive is to the right, and the RECEIVE cassette drive is located next to the printer (on a dual work position terminal, the RECEIVE cassette drive is only associated with work position 1).

Only Teletype Corporation cassettes (Part Number 403580) should be used; others may not function at all or may function with decreased reliability. A Teletype cassette has a white label on the front and a red label on the back with a rectangular notch and two orange tabs along the top edge. The tab on the upper left edge of the cassette may be used when it is desired to prevent information on that cassette from being erased or changed. The outer edge of the tab may be pried up with a fingernail or suitable tool and flipped 180 degrees toward the center of the cassette to expose a hole. The tab may be secured in that position with finger pressure. Should it later be desired to change the information stored on the cassette, the tab may be replaced in its original position, covering the hole.

Each cassette drive (SOURCE, FILE, and RECEIVE) must contain a cassette for normal operation. Raise the clear cover of the cassette drive and insert the cassette into the cassette guide, with the notch on top and the white label facing the operator. Gently lower the cassette into its holder and push it toward the back of the cassette drive until it latches into a vertical position. Close the cassette drive cover. Position the cursor over the name of either the SOURCE, FILE, or RECEIVE cassette on the display, using the CURSOR TAB key, and push the SELECT key to display that cassette index. If this is a new cassette, it may be given a four character (maximum) name now. If this is the cassette desired, according to the index entries, the ENABLE/REWIND key will enable the cassette drive, underline its name on the display, and allow that cassette to be used. The red warning light on the cover indicates that the cassette drive is in use and that the cassette should not be removed!

When finished with a cassette, and it is desired to remove it, the CURSOR TAB key is used to select the appropriate cassette on the index display. Press the ENABLE/REWIND key to rewind the cassette. When the red warning light on the cassette drive goes off, the clear cover may be opened and the EJECT bar may be pushed gently upward and to the rear of the cassette drive. The cassette will rock forward and may be removed by sliding it upward out of the cassette guide. Always close the cassette drive door when not inserting or removing a cassette to prevent the accumulation of dust.

INITIALIZING A CASSETTE

A cassette is initialized when it contains an "empty" index; that is, an index which indicates that no files are stored on the cassette and that no name has yet been assigned to it. This is done automatically when a new cassette is inserted into a cassette drive for the first time, provided that the orange tabs cover the holes in the top edge of the cassette. Initialization may also be used to "erase" a used cassette, again provided that the orange tabs cover the holes, by writing an "empty" index on it, making inaccessible any previously stored files. This can be done only before enabling a cassette or after rewinding it, by selecting the appropriate cassette drive with the CURSOR TAB key, pushing the CURSR RETRN key to place the cursor at the left of the name of the selected cassette drive, and pushing the PAGE DELETE key. The cassette index will then be "erased". The CURSOR TAB key will then position the cursor to the beginning of the space for the cassette name, and a four character (maximum) name may now be assigned from the operator console, if desired, or the cassette may be removed from the cassette drive.

## 9. PRINTER OPERATION

The Diablo HyTerm Model 1610 printer provides a machine-readable (OCR/A font) hard copy of messages originated locally, received from the system, or stored on tape cassettes. These messages may be entered into the AMPS system via a suitable optical character reader.

Control characters do not print. NEW LINE and RETURN functions are performed.

The printer will display 10 characters per inch horizontally and 6 lines per inch vertically, and uses fanfold tractor (pin) feed paper, varying in width between 2 1/4 inches (57.2mm) and 15 inches (381.0mm), for an effective form size between 1 1/4 inches (31.8mm) and 14 inches (355.6mm). Twelve form lengths are available, switch selectable, ranging between 1/6 inch (4.2mm) and 14 inches (355.6mm) (see description of FORM LENGTH switch in this section).

Two control panels allow various options and error recovery procedures to be selected; an exterior one on the right front of the printer, and an interior one under the printer cover.

### Exterior Control Panel

POWER	Red rocker switch controls AC power to printer. Red lamp indicates that power is turned on.
SCROLL	Grey rocker switch allows paper to advance one second after the last character is printed to allow it to be clearly read. Paper reverses when printing is resumed. As OCR/A print quality may suffer, it is recommended that this switch be turned to "OFF".
SET TOF	Grey spring-loaded rocker switch used to set top-of-form for printer electronics after manually positioning paper to print on first line (see Section 10).
FORM FEED	Grey spring-loaded rocker switch moves paper to first line of next form.
RESET	Grey spring-loaded rocker switch turns off error lamp and resets printer electronics after the condition causing an error has been cleared (exception - a printer check error requires operation of the CLEAR button on the interior control panel).
ERROR	Red lamp indicates error condition(s), including cover open and various data transmission errors. It is turned off by the RESET rocker switch or the CLEAR button.

Interior Control Panel

This control panel is located under the printer access cover; to remove the cover, grasp the horizontal aluminum trim bar just above the exterior control panel, lift upward, and remove the panel. To replace it, position the panel approximately in place and push it down.

- CLEAR** Button completely resets the printer electronics, including recovery from errors not affected by the RESET switch.
- DUPLEX** Toggle switch to select full or half duplex operation. This switch should remain in the "FULL" position.
- PARITY** Three-position toggle switch to select method of parity checking (if any) of characters to be printed. This switch should remain in the "MARK" position.
- AUTO LF** Toggle switch to generate a NEW LINE function every time a RETURN function is requested. This switch should remain in the "OFF" position..
- SPACING** Toggle switch to select 10 or 12 characters per inch (horizontal). This switch should remain in the "10" position.
- SPEED** Three-position toggle switch to select receive speeds of 10, 15, or 30 characters per second. This switch should remain in the "30" position.
- FORM LENGTH** Twelve-position rotary switch used with the SET TOF switch on the exterior control panel to determine the length of a form (in inches). If this switch is changed without turning off AC power, manually position the paper to the first line of a form and push the SET TOF switch. The standard form lengths are 1/6 inch (4.2mm) (one line), 3 inches (76.2mm), 3 1/2 inches (88.9mm), 4 inches (101.6mm), 5 1/2 inches (139.7mm), 6 inches (152.4mm), 7 inches (177.8mm), 8 inches (203.2mm), 8 1/2 inches (215.9mm), 11 inches (279.4mm), 12 inches (304.8mm), and 14 inches (355.6mm).

An unlabeled three-position toggle switch is located to the right of the interior control panel. This is the impression control switch, and is used to adjust the printer for different fonts and papers. For OCR/A printing on single-part continuous forms, this switch should remain in the "M" position.

## 10. TERMINAL MAINTENANCE

### PRINTER

The printer must be equipped with paper, ribbon cartridges, and printwheels. In addition, an adequate supply of these items should be kept in storage.

Only ribbon cartridges designed for use with the Diablo HyTerm Model 1610 printer should be used, such as Diablo part numbers 24150 (Teletype #40RC7XXS) (single-strike ribbon) and 24170 (Teletype #40RC7XXYS) (multi-strike ribbon, for less frequent ribbon cartridge changes).

Continuous forms with 1/2 inch (12.7mm) tractor (pin) feed holes on both edges must be used with the printer. Options may include multiple copies (maximum total form thickness, including carbons, is 0.027 inch (0.69mm)), scored edges to allow the tractor feed holes to be neatly removed, and paper color. The standard form width is 9 1/2 inches (241.3mm) and the standard form length is 11 inches (279.4mm), allowing the tractor feed holes to be removed, leaving a standard 8 1/2 inch (215.9mm) by 11 inch (279.4mm) sheet. The printer can accommodate other paper sizes; the width ranging from 2 1/4 inches (57.2mm) to 15 inches (381.0mm) with form lengths from 1/6 inch (4.2mm) to 14 inches (355.6mm).

The printwheel may need to be removed for cleaning or as a result of damage. The OCR/A printwheel is Diablo part number 38144 (Teletype #40TW7XXZS). It is recommended that power be turned off when replacing it.

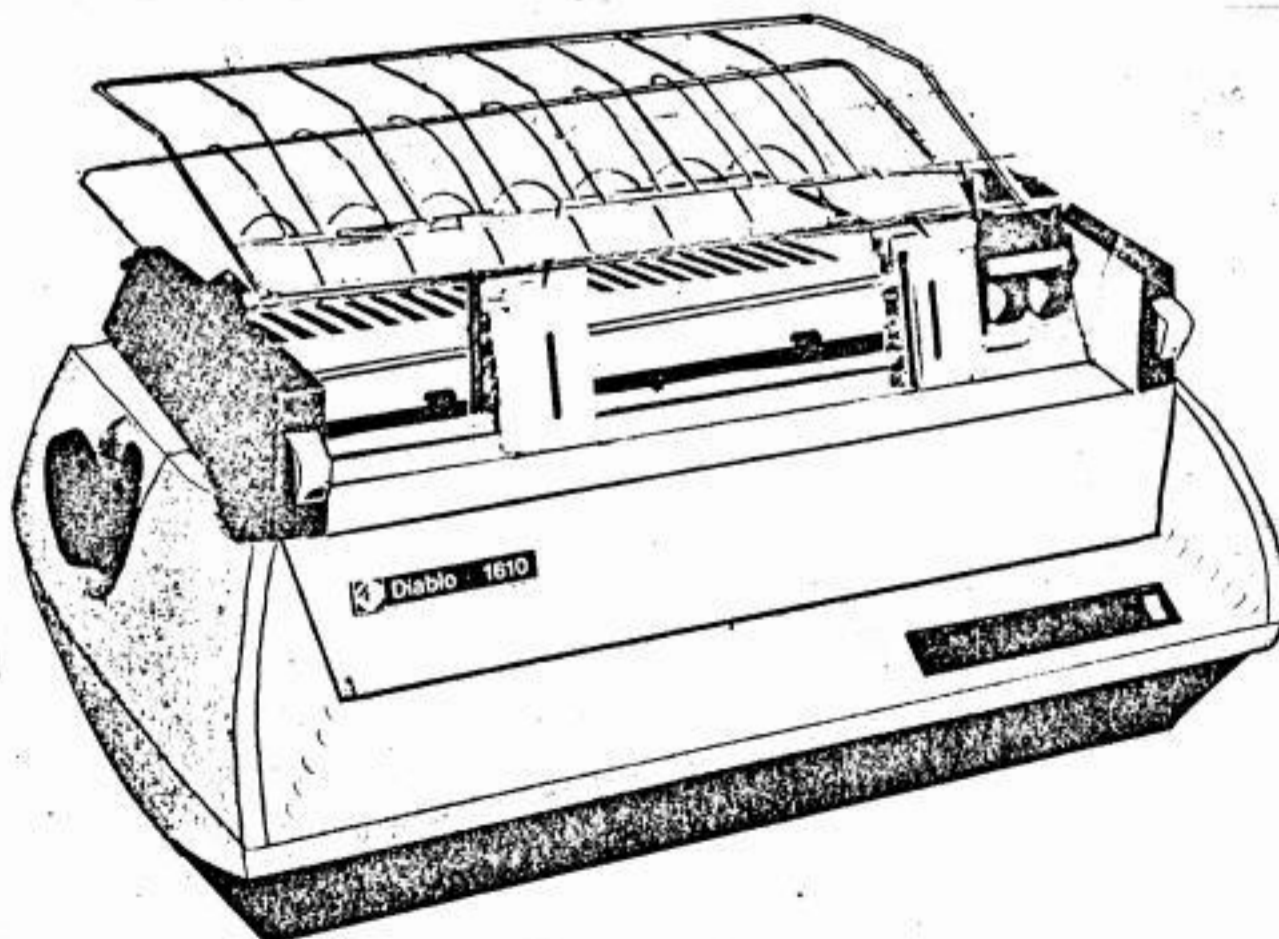

### Printwheel Replacement

Remove the printer access cover (see Section 11).

Remove the ribbon cartridge (see Section 11).

Pull the printwheel carriage away from the platen.  
It will snap into the position shown.

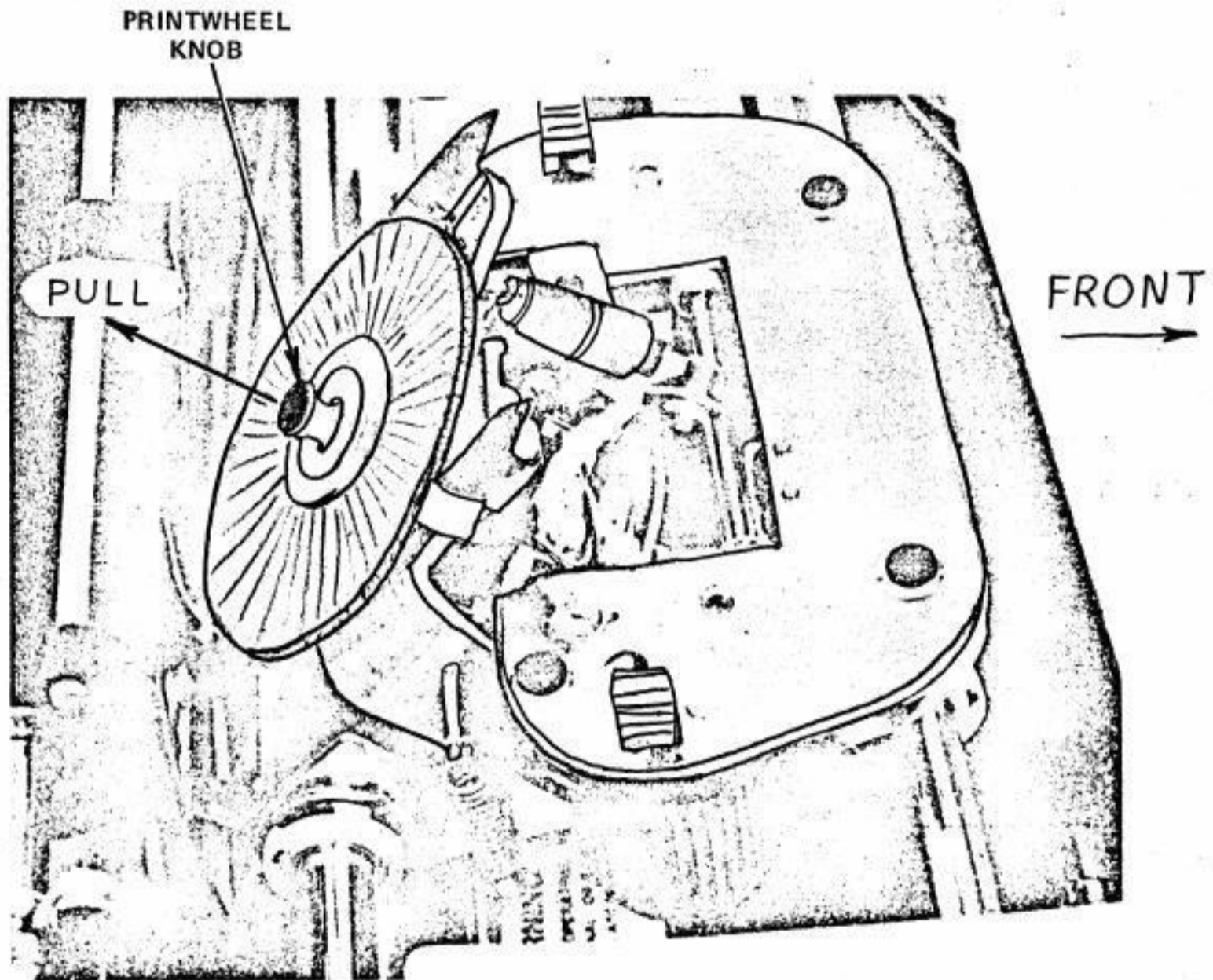

Remove the printwheel by pulling on the hard rubber knob at the printwheel hub.

When not in use, store the printwheel in its protective case.

To replace the printwheel, position it over the printwheel shaft, rotating it until its rectangular alignment hole is lined up with the alignment tab on the shaft.

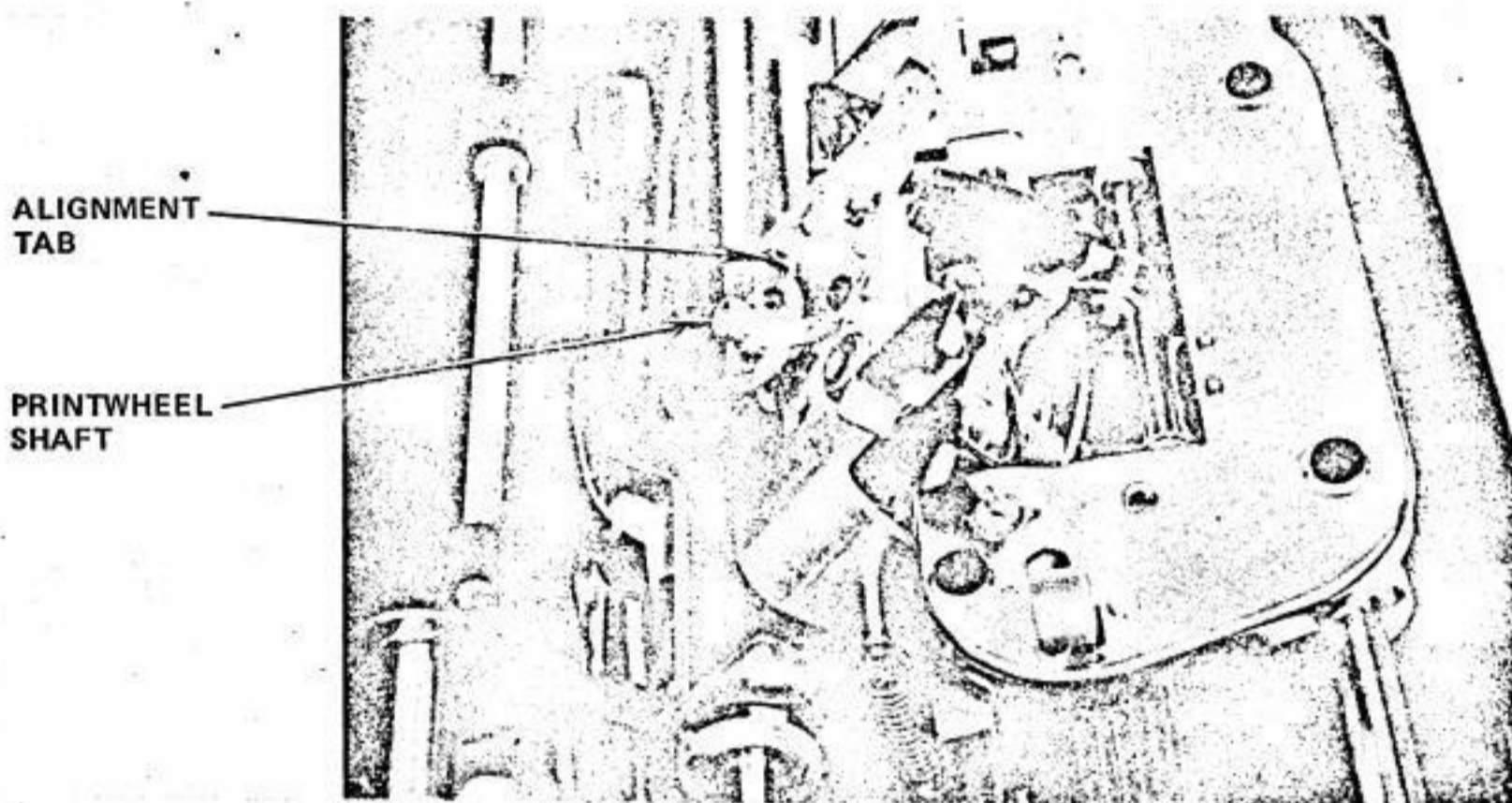

Press the hub of the printwheel firmly to lock it in place.

Push the carriage back into the printing position; it will snap into place.

Replace the ribbon cartridge (see Section 11).

Replace the printer access cover (see Section 11).

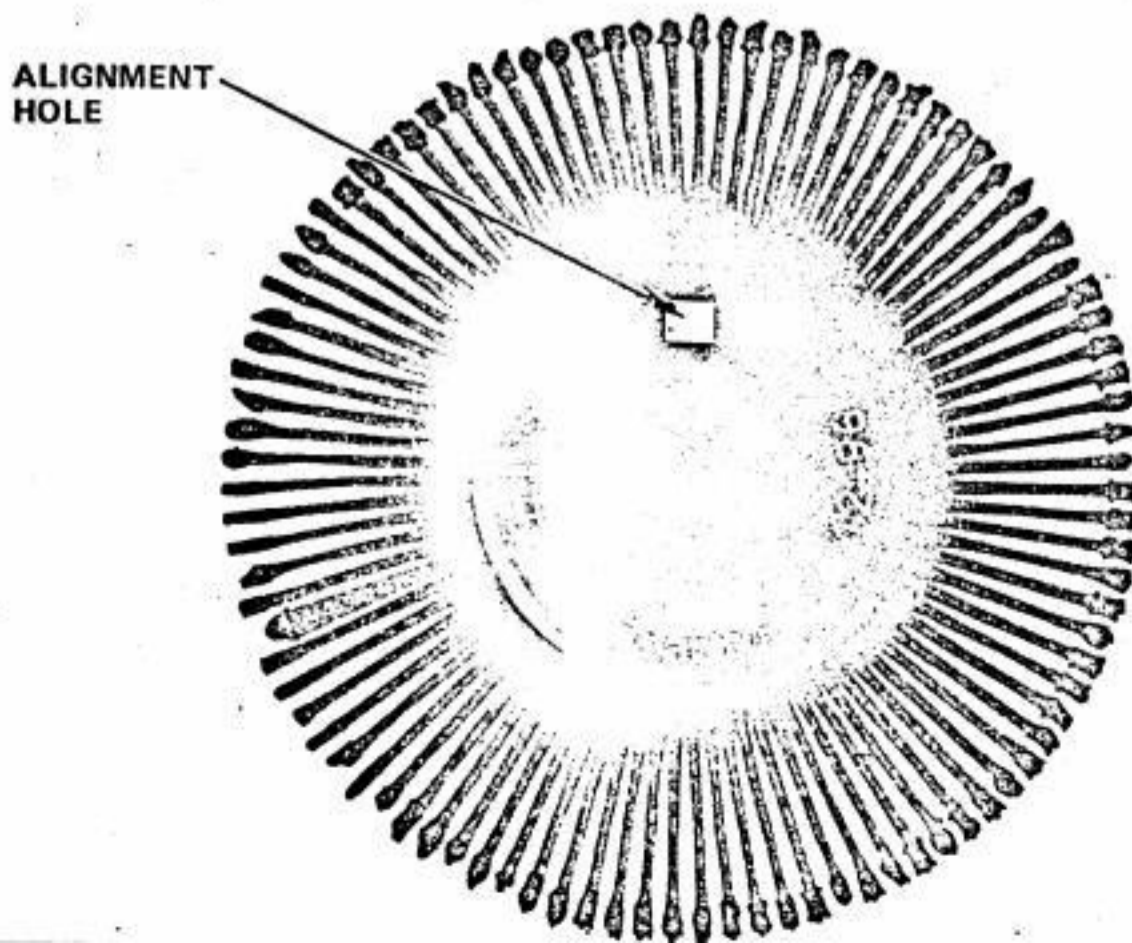



CASSETTE DRIVE

Using Teletype Part Number 337401 Recording Head Cleaner and a cotton swab, the tape head, hub drives and tape cassette locating pins should be cleaned once each week, or sooner, if dirt and oxide deposits are noticed.

Tape cassettes for the terminal appear to be standard Philips-type tape cassettes. They are not! There are significant differences which greatly increase the reliability of the Teletype-supplied tape cassettes when compared to conventional ones. Use only Teletype Model 40 Tape Cassettes (Teletype Part Number 403580) with this system; other tape cassettes will not work reliably.

## 11. PAPER AND RIBBON REPLACEMENT

### DIABLO HYTERM MODEL 1610 PRINTER

#### Paper Replacement

Pull the 3-roller paper bail toward the front of the printer, away from the platen.

Release both tractor feed paper clamps.

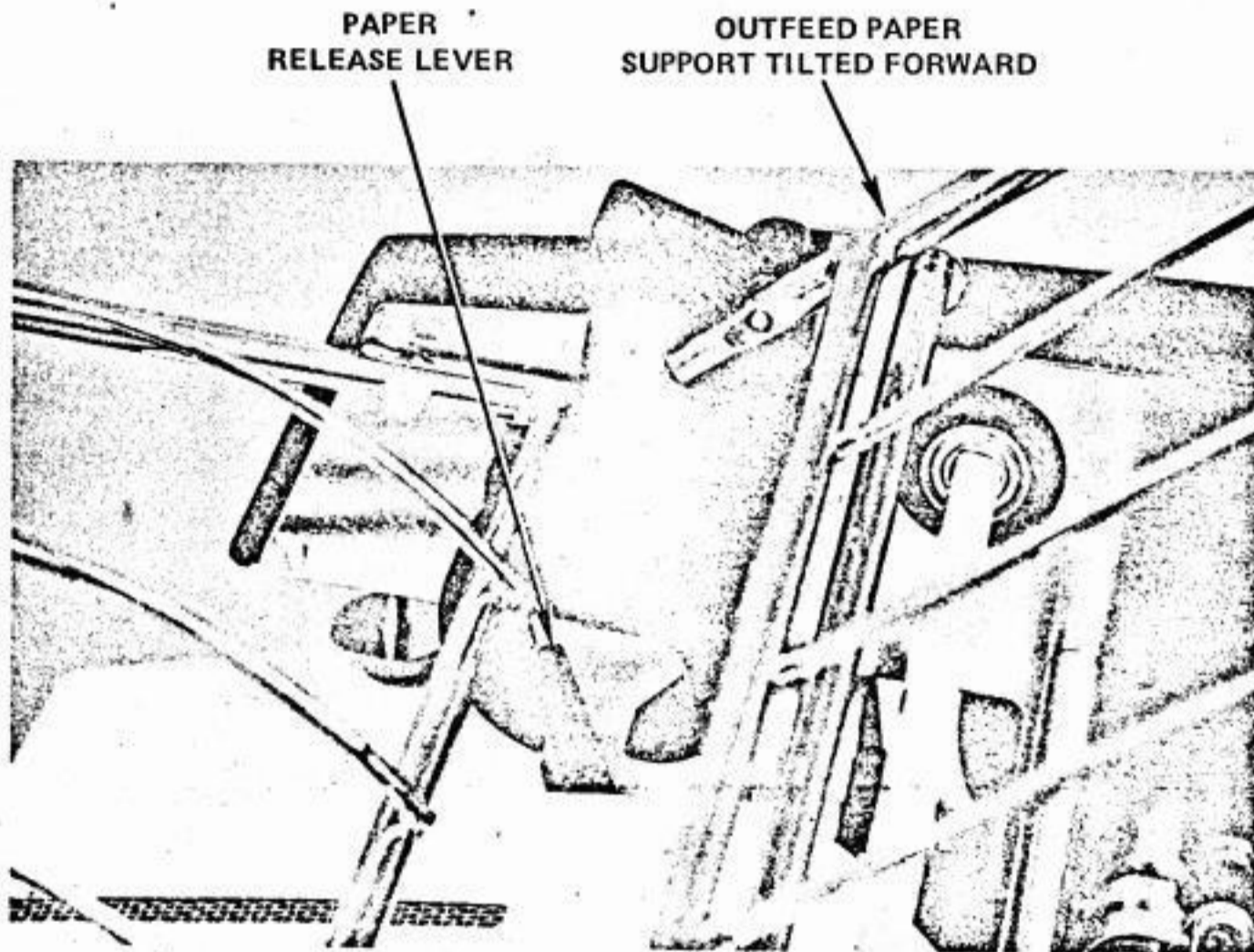

Tip the outfeed (top) paper support (wire frame) up and forward until a snap is heard and it rests in the forward position. This restores tension on the paper feed rollers so that turning the platen knobs will pull paper through the printer.

Insert the leading edge of the continuous form paper into the printer, over the infeed (lower) paper support (a third (lowest) wire frame paper support is for use without the tractor feed assembly), and down behind the platen. Using the platen knobs, turn the platen until the leading edge of the paper is several inches above the tractor feed paper clamps.

Push the outfeed paper support back down to its at-rest position. This releases tension on the paper feed rollers so that the paper can be pulled freely through the printer.

Place the form over the teeth of the left-hand tractor assembly and close the clamp.

Align the form so that the leading edge is horizontal, place it over the teeth of the right-hand tractor assembly, and close the clamp. If necessary, adjust the right-hand tractor assembly by loosening the tractor clamp screw and sliding the tractor left or right to lightly tension the paper. Retighten the tractor clamp screws following adjustment.

Horizontal form positioning can best be done after the form is already installed in both tractors. Both tractor clamp screws may be loosened, the tractor assemblies moved, and the tractor clamp screws re-tightened.

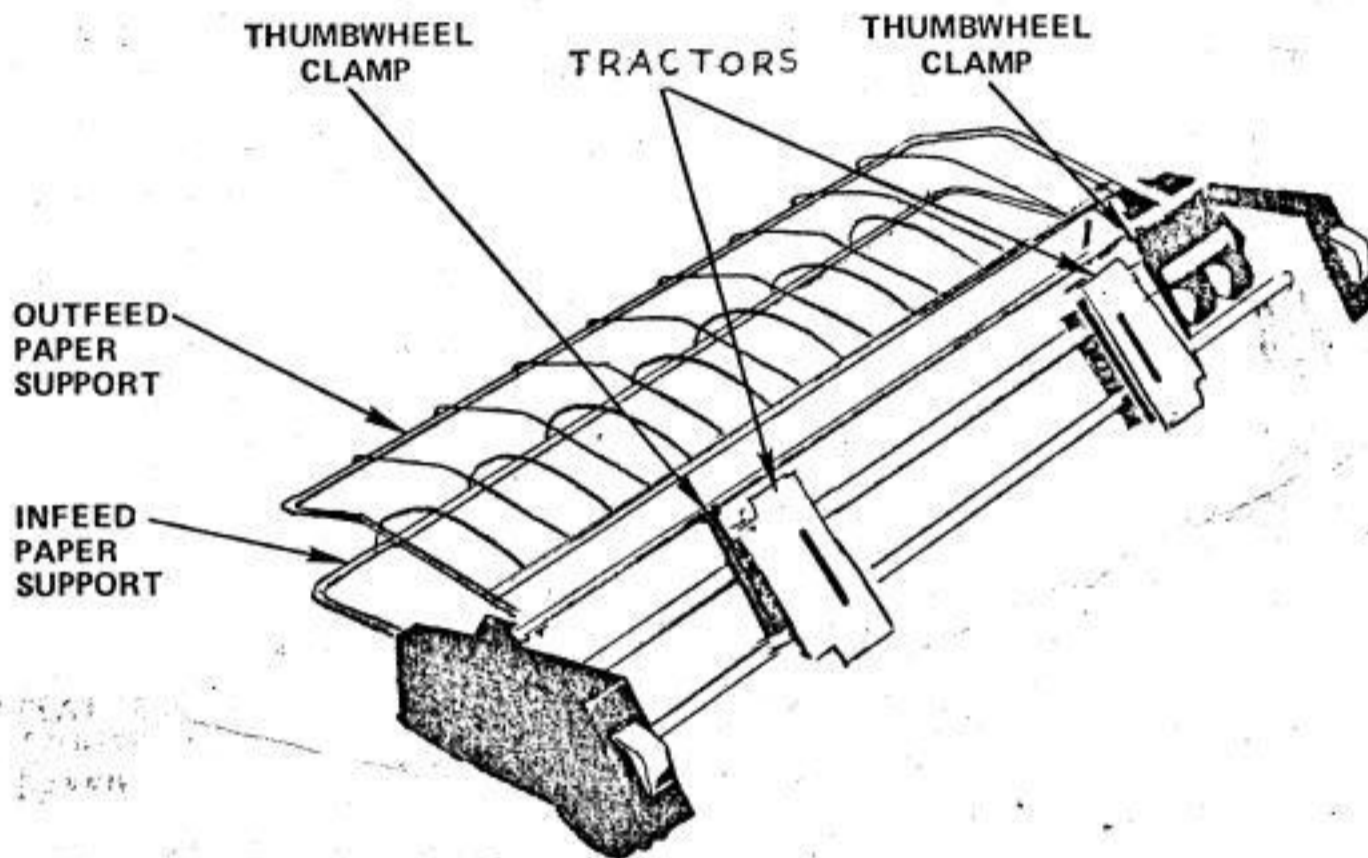

Push the 3-roller paper bail back against the platen.

Position the next form for the first line of printing, using the platen knobs; the right-hand platen knob may be pushed in and rotated for fine positioning.

Push the SET TOF switch.

### Ribbon Cartridge Replacement

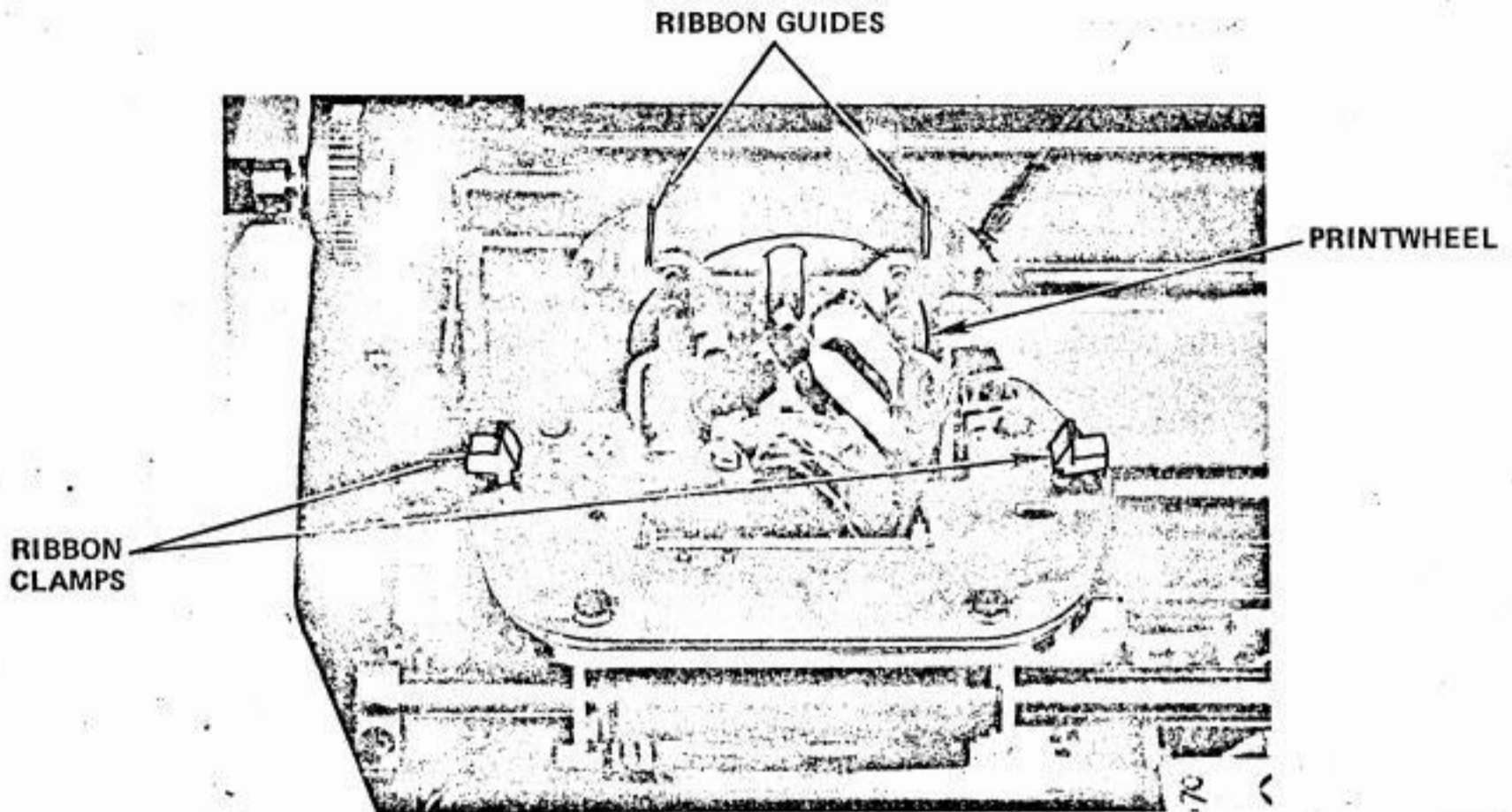

Remove the printer access cover.

Push down both ribbon clamps and lift the old ribbon cartridge out of the printer.

Turn the white ribbon advance knob on the new ribbon cartridge, in the direction indicated by the arrow on the ribbon cartridge casing, enough to remove all slack from the ribbon.

Holding the ribbon cartridge so that the white ribbon advance knob is toward the left side of the printer, guide the ribbon around the 2 metal ribbon guides and between the printwheel and the paper. Push the ribbon cartridge down until the ribbon clamps snap into position.

Replace the access cover.

## 12. WHEN TROUBLE OCCURS

Before reporting trouble, check the following:

Make certain that all plugs on power cords are properly seated in power outlets.

Make certain all switches are turned on.

If power plugs are properly connected, all switches are on, and no lamps are lit, determine whether power supply in the building has failed by checking lights in the room, another terminal, or any other electrically operated machines in the office. If there is no power, report this trouble as you would report no lights.

If power is available in the building, the questions on the next page should be answered by the operator or local supervisor to determine if the Teletype Corporation equipment is operating properly or if the trouble is in the system.

### CASSETTE DRIVE TROUBLE SHOOTING

The cassette drive performs a rewind every time a new cassette is loaded and performs a write-read test on cassettes upon which data may be recorded (hole covered). With power turned on in the system, you can see the end-of-tape lamp through the clear window in the cassette drive. When you insert a cassette on which data may be written, the external red indicator lamp will turn on and the cassette will rewind and move the tape back and forth a couple of times. If the cassette and the cassette drive are functional, the red indicator lamp will turn off. If the cassette failed the write-read test, the indicator lamp will blink. Remove and reinsert the cassette to repeat the test. If you insert a cassette up on which data may not be written (hole exposed), it should only rewind and the external indicator lamp should turn off.

TROUBLE SHOOTING QUESTIONSYESNO

1. Is the power turned on to all the pedestals?

(AC plugged in, pedestal switches on, fans moving air at rear of pedestal?)

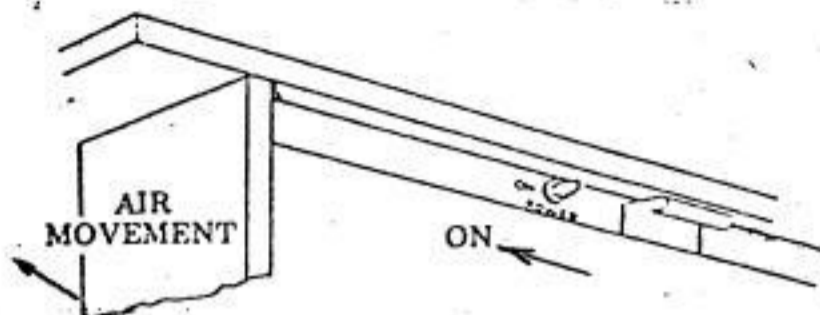

Go to 2.

Correct locally.

2. Is INDEX key on each operator console lit after the Terminal Program is loaded?

Go to 3.

Report as trouble in equipment.

3. Is cursor displayed on the display monitor? (Pedestal, cabinet and display power switches on and brightness turned up?)

Go to 4.

Report as trouble in equipment.

4. Does printer copy message selected from index when PRINT key is pushed? (Power turned on at printer, paper feeds out when FORM FEED switch is pushed.)

Go to 5.

Check ribbon. Report as trouble in equipment.

5. Can data be entered from the operator console to the display monitor?

Go to 6.

Report as trouble in equipment.

6. Do any operational problems appear to be common to the other work position (if any) on the same terminal?

Go to 7.

Report as trouble in equipment.

7. Does operator console self-test operate properly? (See next page.)

Report as trouble in the system.

Report as trouble in equipment.

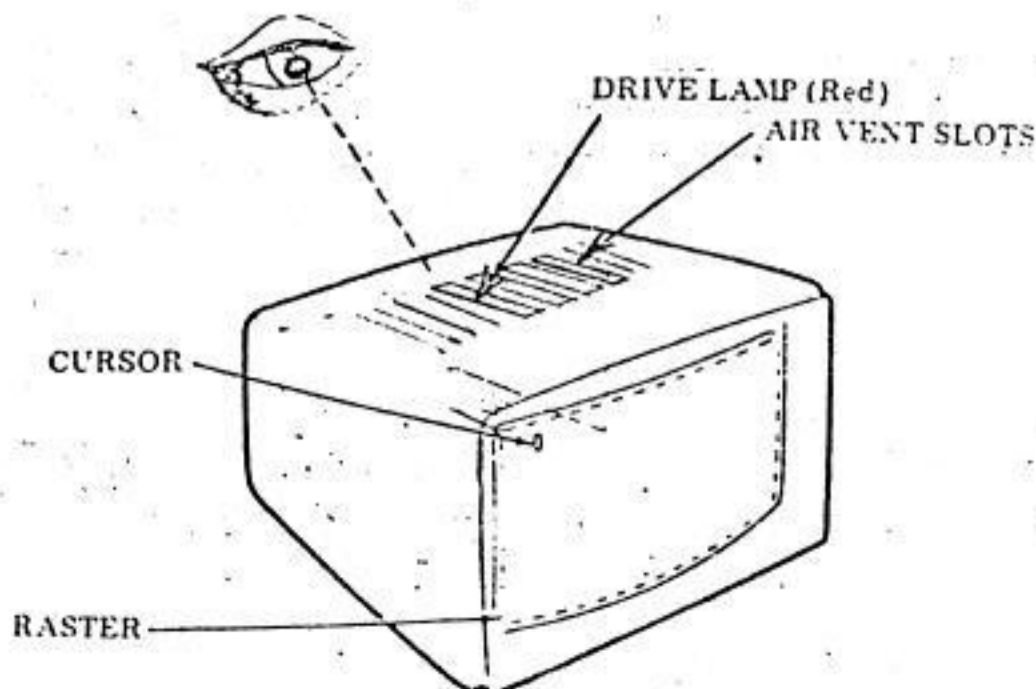

INTERNAL KEYBOARD DISPLAY TROUBLE SHOOTING

Ask the following questions:

Is AC power on?

Is INDEX lamp lighted after Terminal Program is loaded?



Is cursor displayed on monitor? (Monitor switch ON and brightness turned up.)

Is red drive lamp lighted in monitor? (Can be seen through air vent slots (10th slot from right) at top rear of monitor cover.)

Can raster (white outline of screen) be displayed? (Brightness turned all the way up.)

Can data be entered from operator console and displayed on monitor?

Can certain keys be made to light in operator console test mode? (See next page.)

Is the character image displayed on monitor distorted?

Does character on monitor correspond to character entered from the operator console?

OPERATOR CONSOLE SELF-TEST

Local analysis of the operator console can be started by depressing the RETURN and QUOTES keys simultaneously with more force than is required for normal operation (repeat zone position). The red TEST light on the PAGE DELETE key will light (until this self-test is concluded, ignore any characters that may appear on the display) and the audible alarm may sound.

NOTE: All lamps may flash and the audible alarm may sound continuously when this test is started. Lamps can be turned off individually, as shown in the following table, or the operator may conclude the test and restart it.

The self-test of the operator console may be concluded by fully depressing the RETURN and ESC P keys simultaneously (repeat zone position).

Various portions of the operator console circuitry may be tested, and a successful completion of the testing verified by the action of the lamps in the operational control keys, in response to various keys on the keyboard, as shown in the table on the next page.

NOTE: As only capital letters will start some of the tests, you may find it desirable to use the CAPS LOCK key.

OPERATIONAL CONTROL INDICATOR KEY	DEPRESS THIS KEY TO AFFECT LAMP		
	ON	OFF	FLASH
SELECT	A	SOH	
INDEX	C	ETX	→
BROWSE	D	EOT	
STORE	G	BEL	PREV PAGE
SEND	F	ACK	
PRINT	E	ENQ	
RECEIVE	B	STX	↓
ENABLE/REWIND	J	NEW LINE	PAGE DELETE
GROUP EXPAND	O	SI	
FORM ENTER	N	SO	
MARGIN RELEASE	M	RETURN	COPY
LEFT MARGIN	L	FF	MOVE
RIGHT MARGIN	K	VT	
TOP MARGIN	I	REQ NEW LINE	
BOTTOM MARGIN	H	←	NEXT PAGE

If any of these operations do not produce the proper response, the operator console is defective.

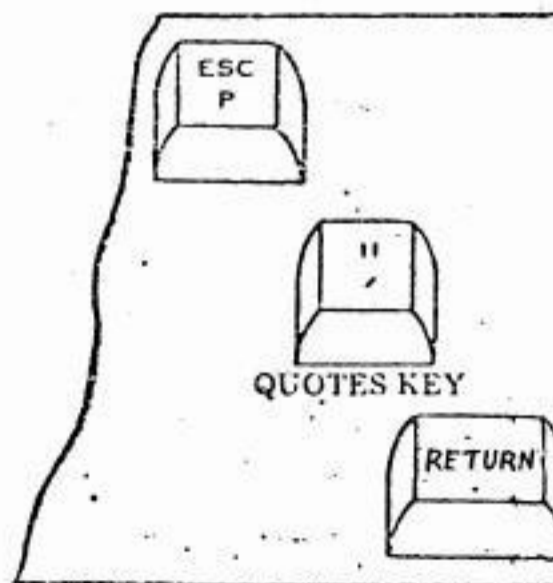



PRINTER ERROR RECOVERY

<u>ERROR INDICATION</u>	<u>POSSIBLE CAUSES</u>	<u>REMEDIAL ACTION</u>
Audible Alarm Sounds, Error Lamp Is Lit	Parity or Framing Error	Locate erroneous character(s), represented by "Y" symbol. Decide whether correct character can be ascertained from surrounding text. If errors are excessive, check SPEED and PARITY switches. Request PRINT again, if necessary.
	Printer Check	Push CLEAR button. Request PRINT again, if necessary.
	Cover Open	Push CLEAR. Close printer access cover.
Audible Alarm Sounds, Error Lamp Not Lit	Right Margin Exceeded	Undefined in this implementation. No action required.
	BEL Code Received	Expected effect. No action required.
Printing On Platen	Paper Out	Insert new paper (see Section 11). Push RESET. Request PRINT again, if necessary.