

BULLETIN 1037B
ISSUE 6
SUPERSEDES
ALL ISSUES OF
1037B, 1094B AND 1114B

TELETYPE

PRINTING TELEGRAPH SYSTEMS

BULLETIN 1037B
ISSUE 6

TYPE BAR PAGE PRINTER

(MODEL 15)

PARTS CATALOG

CORPORATION
SUBSIDIARY OF
Western Electric Company
CHICAGO, U.S.A.

BULLETIN 1037B
ISSUE 6
SUPERSEDES
ALL ISSUES OF
1037B, 1094B AND 1114B

TELETYPE

PRINTING TELEGRAPH SYSTEMS

BULLETIN 1037B
ISSUE 6

TYPE BAR PAGE PRINTER (MODEL 15) PARTS CATALOG



ATTENTION—BELL SYSTEM ONLY
WHEN ORDERING PARTS FROM THIS BULLETIN, EACH NUMBER SHOULD BE PRECEDED BY THE LETTERS TP, WITHOUT PARENTHESES, IN ORDER TO IDENTIFY THE ITEM AS ONE TO BE SECURED FROM THE TELETYPE CORPORATION.

LIST OF EFFECTIVE PAGES
 JANUARY, 1956
 (SUPERSEDES FEBRUARY, 1953 ISSUE)

PAGE NUMBERS	CHANGE IN EFFECT	PAGE NUMBERS	CHANGE IN EFFECT
A to F	Original		
I-1 to I-76	Original		
II-1 to II-4	Original		
III-1 to III-3	Original		
IV-1 to IV-4	Original		
V-1 to V-31	Original		

The above list indicates the effective pages as of the date of issue. Upon receipt of change pages, insert them numerically and discard any superseded pages.

TABLE OF CONTENTS

PREFACE	PAGE
Photographs - - - - -	C through E
Sample Printing - - - - -	F
 SECTION I	
Base - - - - -	I-1 through I-9
Keyboard - - - - -	I-10 through I-13
Typing Unit - - - - -	I-14 through I-40
Motor Units- - - - -	I-41 through I-45
Filters - - - - -	I-46
Cover- - - - -	I-47
Cover Front Plates - - - - -	I-48
Copyholders - - - - -	I-49
Accessories - - - - -	I-50 through I-76
 SECTION II	
BELL SYSTEM UNITS - - - - -	II-1 through II-4
 SECTION III	
OLD STYLE PARTS- - - - -	III-1 through III-3
 SECTION IV	
NOTES OF EXPLANATION - - - - -	IV-1 through IV-4
 SECTION V	
NUMERICAL INDEX - - - - -	V-1 through V-31



TELETYPE MODEL 15 SENDING - RECEIVING PAGE PRINTER SET

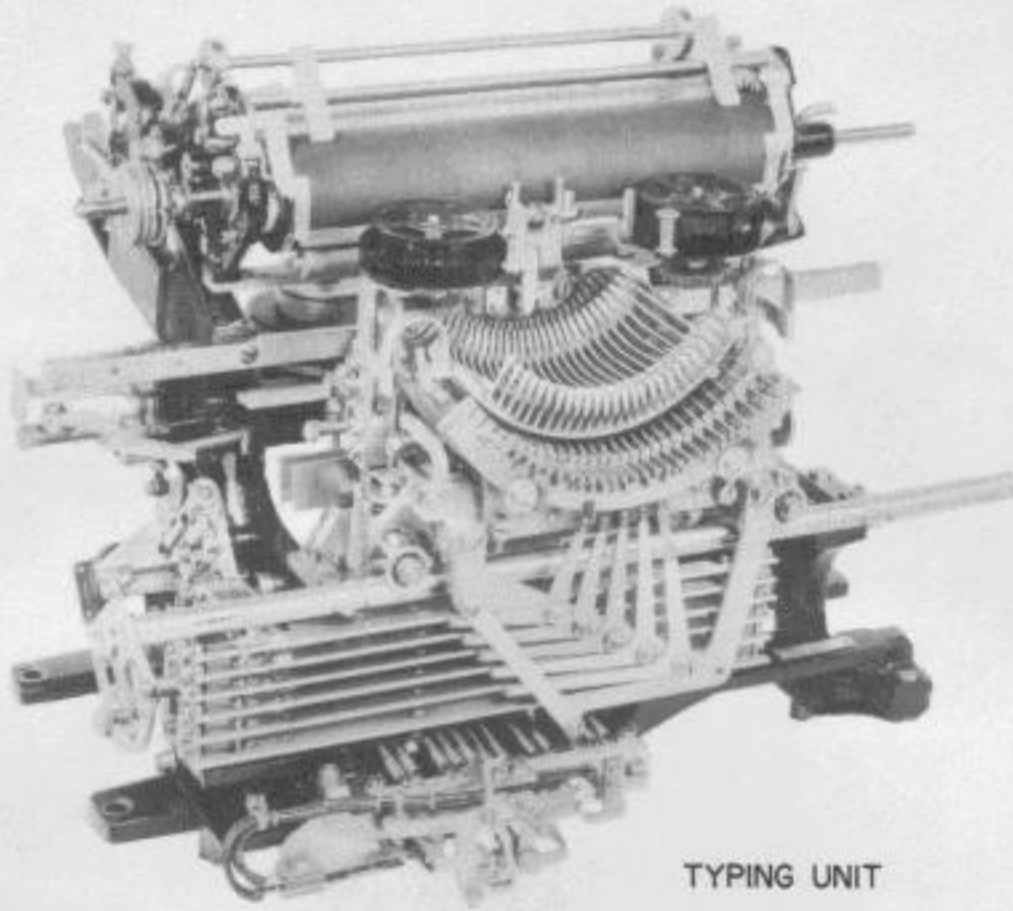

TYPING UNIT

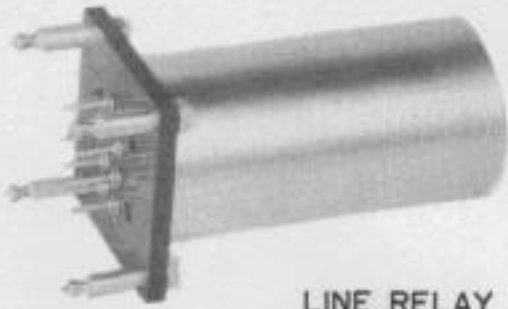

LINE RELAY

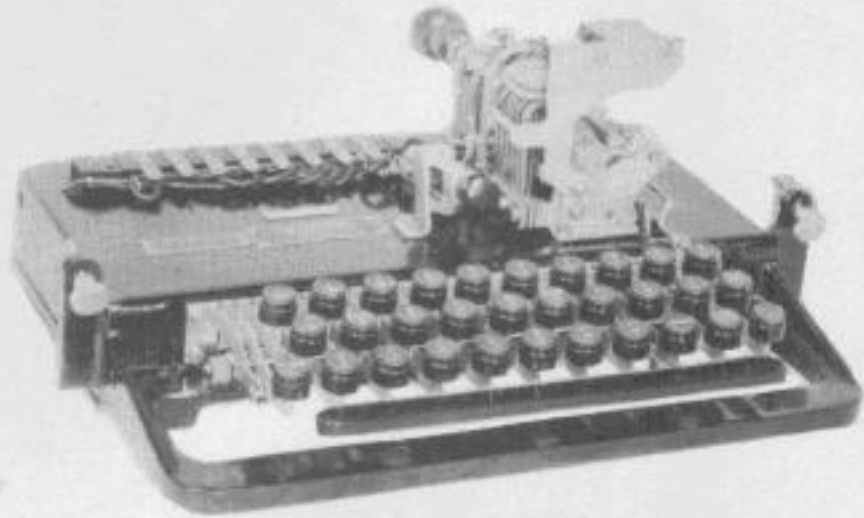

KEYBOARD

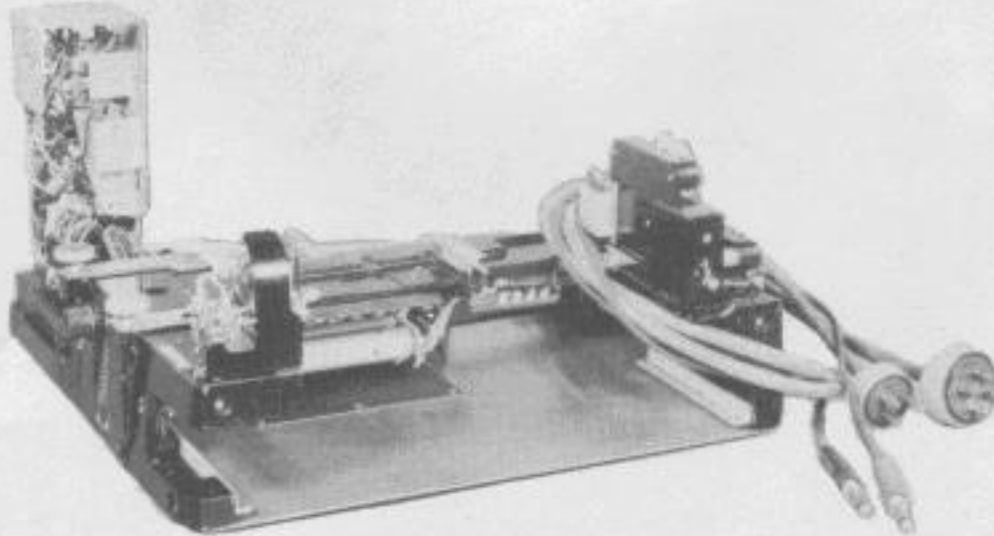

BASE

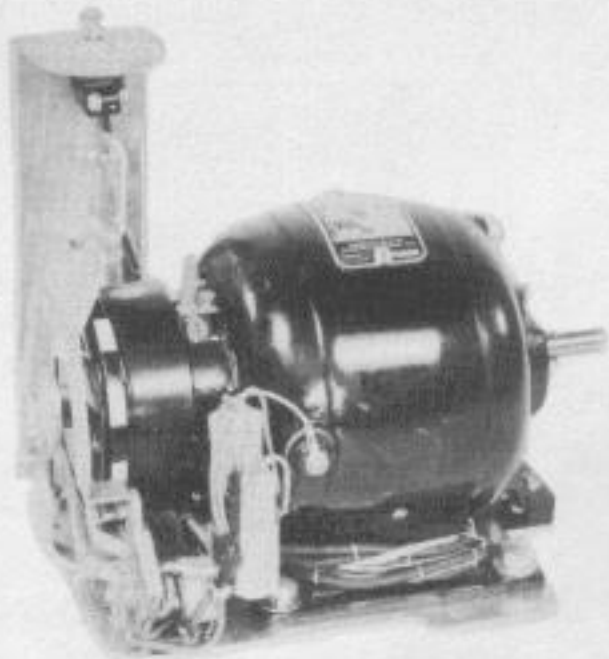

MOTOR UNIT
(GOVERNED)



MOTOR UNIT
(SYNCHRONOUS)

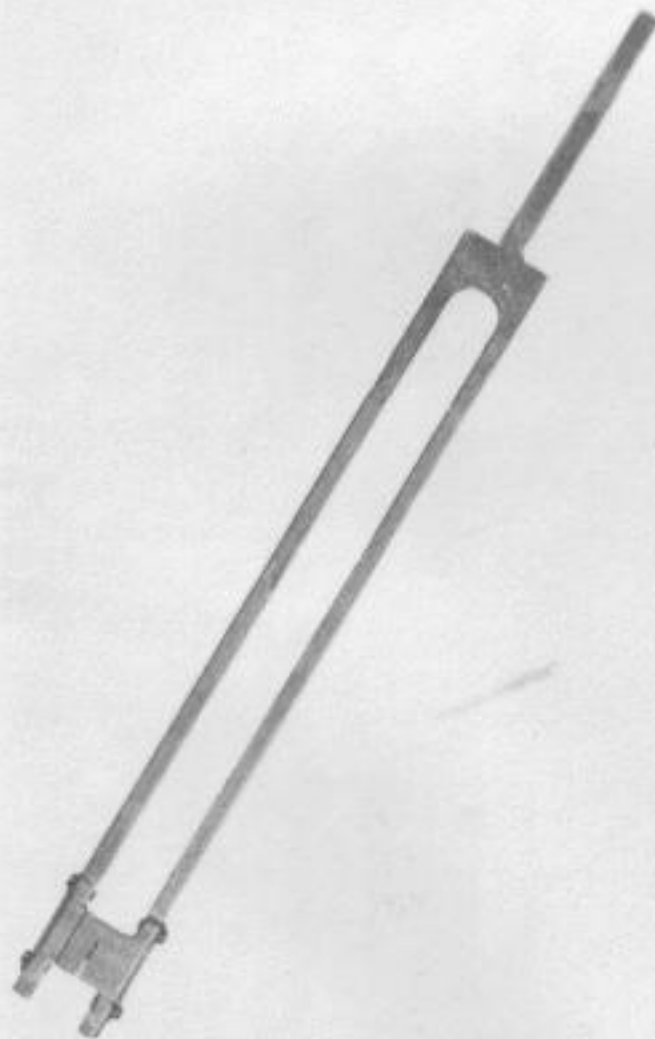

SPEED INDICATOR (TUNING FORK)
PART NUMBER 103628
(87.6 V.P.S.)

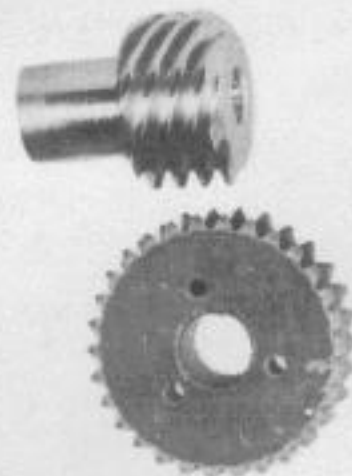

SET OF GEARS

SAMPLE PRINTING ILLUSTRATING THE VARIOUS STYLES OF TYPE

The following copy has been produced on a Model 15 printer equipped with:

MURRAY STYLE CHARACTERS

THE QUICK BROWN FOX JUMPED OVER THE LAZY DOGS BACK 1234567890 TIMES.
 ABCDEFGHIJKLMNOPQRSTUVWXYZ 1234567890'†↗↘↓↙←↘+/∞⊕⊙.
 †,X=:'-+()"/*√. 1131537
 \$!&£'()" /: ;? ,. 8482848\$& ,"/.

GOTHIC STYLE CHARACTERS

THE QUICK BROWN FOX JUMPED OVER THE LAZY DOG'S BACK 1234567890 TIMES.
 ABCDEFGHIJKLMNOPQRSTUVWXYZ \$!&£'()" /: ;? ,.

LONG GOTHIC STYLE CHARACTERS

THE QUICK BROWN FOX JUMPED OVER THE LAZY DOG'S BACK 1234567890 TIMES.
 ABCDEFGHIJKLMNOPQRSTUVWXYZ \$!&£'()" /: ;? ,.

LARGE GOTHIC STYLE CHARACTERS

THE QUICK BROWN FOX JUMPED OVER THE DOG.
 ABCDEFGHIJKLMNOPQRSTUVWXYZ

9\$&# ,"/. \$!&£'()" /: ;? ,. 1 1 3 1 5 3 7
 8 4 8 2 8 4 8
 1234567890

NOTE: SEE PAGE I-36 FOR SIZE OF CHARACTERS AS PRINTED. VARIATIONS IN HORIZONTAL SPACING MAY BE OBTAINED BY THE USE OF ONE OF THE SETS OF PARTS SHOWN ON PAGES I-56 AND I-69. VERTICAL SPACING MAY BE INCREASED BY USING THE SET OF PARTS SHOWN ON PAGE I-57.

SECTION I

BASIC PARTS AND ACCESSORIES

PAGES I-1 THROUGH I-76

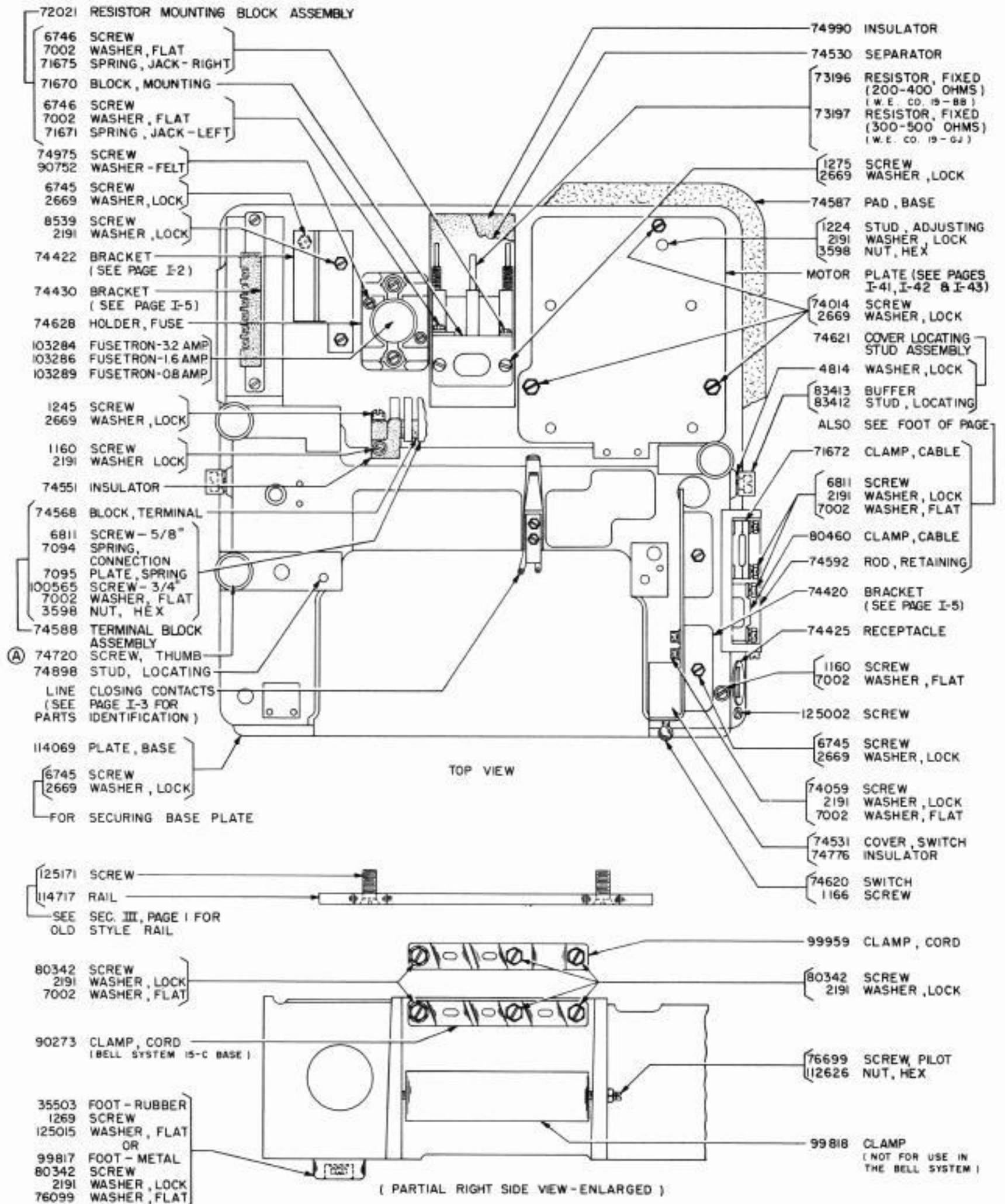

- 72021 RESISTOR MOUNTING BLOCK ASSEMBLY
- 6746 SCREW
- 7002 WASHER, FLAT
- 71675 SPRING, JACK - RIGHT
- 71670 BLOCK, MOUNTING
- 6746 SCREW
- 7002 WASHER, FLAT
- 71671 SPRING, JACK - LEFT
- 74975 SCREW
- 90752 WASHER - FELT
- 6745 SCREW
- 2669 WASHER, LOCK
- 8539 SCREW
- 2191 WASHER, LOCK
- 74422 BRACKET (SEE PAGE I-2)
- 74430 BRACKET (SEE PAGE I-5)
- 74628 HOLDER, FUSE
- 103284 FUSETRON-32 AMP
- 103286 FUSETRON-16 AMP
- 103289 FUSETRON-08AMP
- 1245 SCREW
- 2669 WASHER, LOCK
- 1160 SCREW
- 2191 WASHER, LOCK
- 74551 INSULATOR
- 74568 BLOCK, TERMINAL
- 6811 SCREW - 5/8"
- 7094 SPRING, CONNECTION
- 7095 PLATE, SPRING
- 100565 SCREW - 3/4"
- 7002 WASHER, FLAT
- 3598 NUT, HEX
- 74588 TERMINAL BLOCK ASSEMBLY
- (A) 74720 SCREW, THUMB
- 74898 STUD, LOCATING
- LINE CLOSING CONTACTS (SEE PAGE I-3 FOR IDENTIFICATION)
- 114069 PLATE, BASE
- 6745 SCREW
- 2669 WASHER, LOCK
- FOR SECURING BASE PLATE

- 74990 INSULATOR
- 74530 SEPARATOR
- 73196 RESISTOR, FIXED (200-400 OHMS) (W. E. CO. 19-88)
- 73197 RESISTOR, FIXED (300-500 OHMS) (W. E. CO. 19-02)
- 1275 SCREW
- 2669 WASHER, LOCK
- 74587 PAD, BASE
- 1224 STUD, ADJUSTING
- 2191 WASHER, LOCK
- 3598 NUT, HEX
- MOTOR
- 74014 SCREW
- 2669 WASHER, LOCK
- 74621 COVER LOCATING STUD ASSEMBLY
- 4814 WASHER, LOCK
- 83413 BUFFER
- 83412 STUD, LOCATING
- ALSO SEE FOOT OF PAGE
- 71672 CLAMP, CABLE
- 6811 SCREW
- 2191 WASHER, LOCK
- 7002 WASHER, FLAT
- 80460 CLAMP, CABLE
- 74592 ROD, RETAINING
- 74420 BRACKET (SEE PAGE I-5)
- 74425 RECEPTACLE
- 1160 SCREW
- 7002 WASHER, FLAT
- 125002 SCREW
- 6745 SCREW
- 2669 WASHER, LOCK
- 74059 SCREW
- 2191 WASHER, LOCK
- 7002 WASHER, FLAT
- 74531 COVER, SWITCH
- 74776 INSULATOR
- 74620 SWITCH
- 1166 SCREW

- 125171 SCREW
- 114717 RAIL
- SEE SEC. III, PAGE I FOR OLD STYLE RAIL

- 80342 SCREW
- 2191 WASHER, LOCK
- 7002 WASHER, FLAT
- 90273 CLAMP, CORD (BELL SYSTEM IS-C BASE)
- 35503 FOOT - RUBBER
- 1269 SCREW
- 125015 WASHER, FLAT OR
- 99817 FOOT - METAL
- 80342 SCREW
- 2191 WASHER, LOCK
- 76099 WASHER, FLAT

- 99959 CLAMP, CORD
- 80342 SCREW
- 2191 WASHER, LOCK
- 76699 SCREW, PILOT
- 12626 NUT, HEX
- 99818 CLAMP (NOT FOR USE IN THE BELL SYSTEM)

(A) SEE SEC. IV FOR EXPLANATION

BASE

ORIGINAL

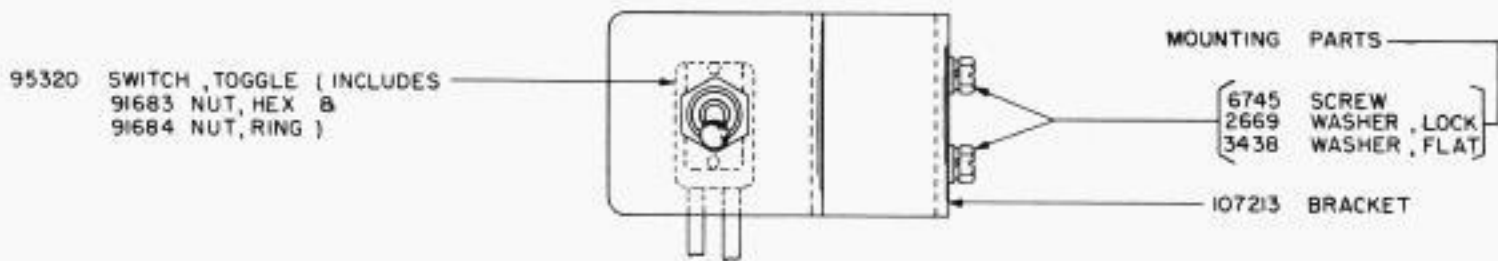

107269 POLAR-NEUTRAL TOGGLE SWITCH
(EXCLUDES MOUNTING PARTS)

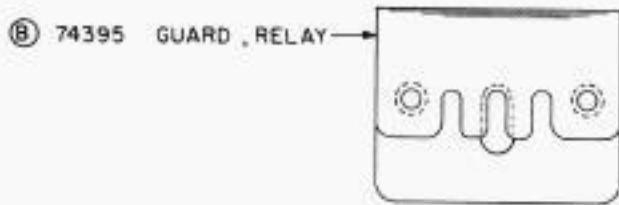

- (B) 74821 RESISTOR, FIXED (810 - 2000 OHMS) 110 V
- 90248 RESISTOR, FIXED (610 - 4000 OHMS) 220 V
- (B) 74614 RESISTOR, FIXED (600 - 2000 OHMS) 110 V
- 90247 RESISTOR, FIXED (1400 - 2000 OHMS) 220 V
- (B) 75436 RESISTOR, FIXED (1000 - 2000 OHMS) 110 V
- 90246 RESISTOR, FIXED (2000 - 4000 OHMS) 220 V

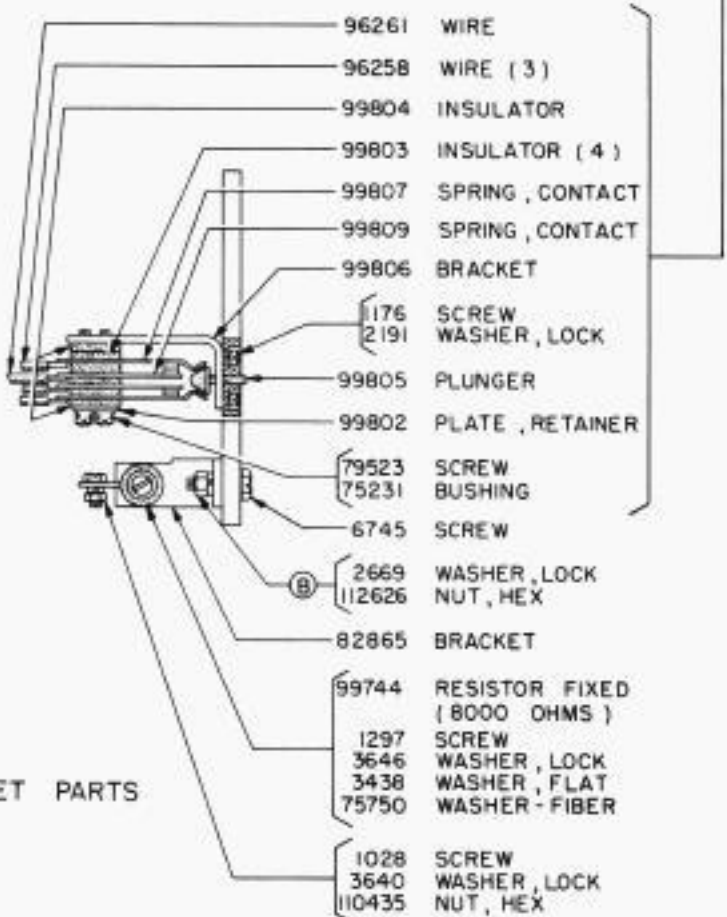
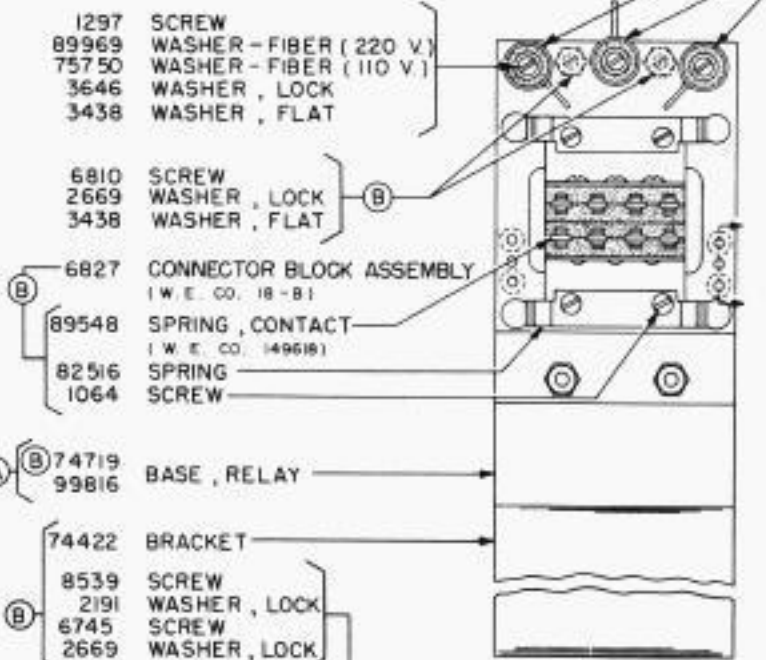
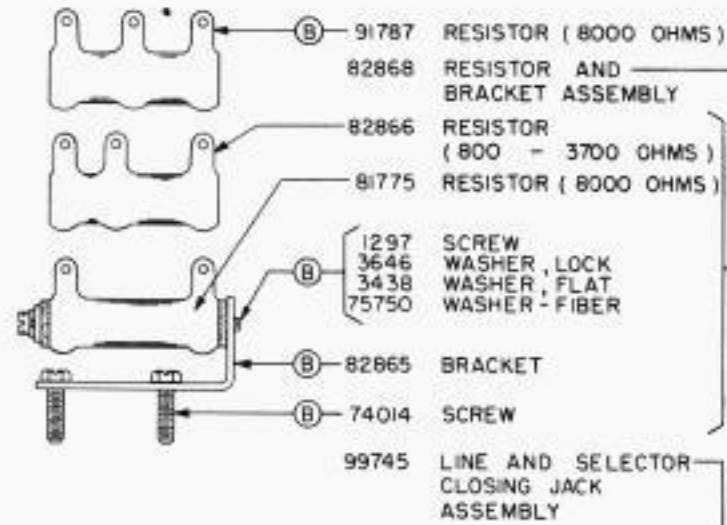

LINE RELAY BRACKET PARTS

- 74575 CABLE, LINE RELAY
- (B) 91789 CABLE, LINE RELAY

(A) SEE SEC. IV FOR EXPLANATION
(B) 91786 SET OF PARTS FOR RELAY MOUNTING - .020 AMP. (INCLUDES ALL PARTS MARKED (B) ON THIS PAGE AND PAGE I-3)

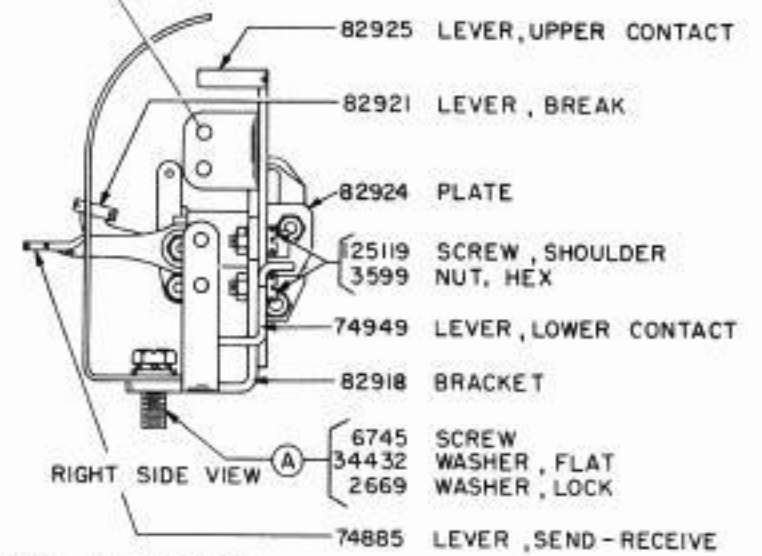
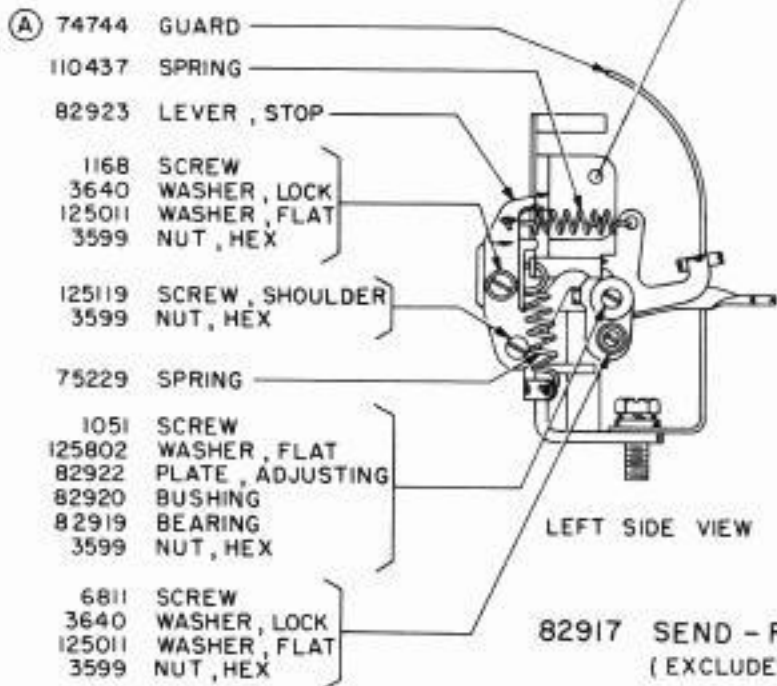
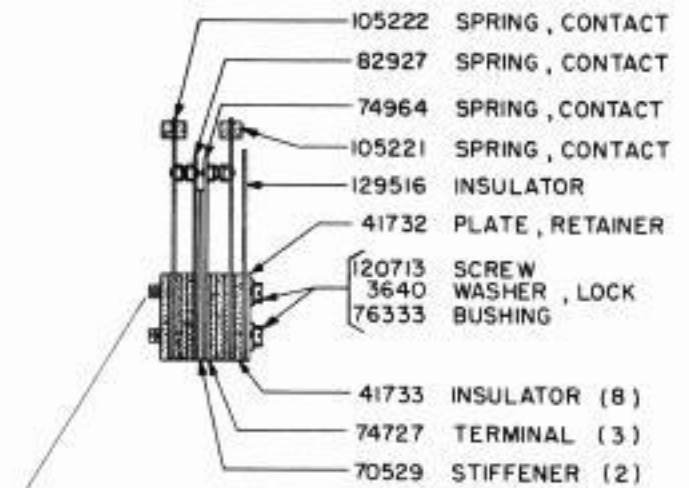
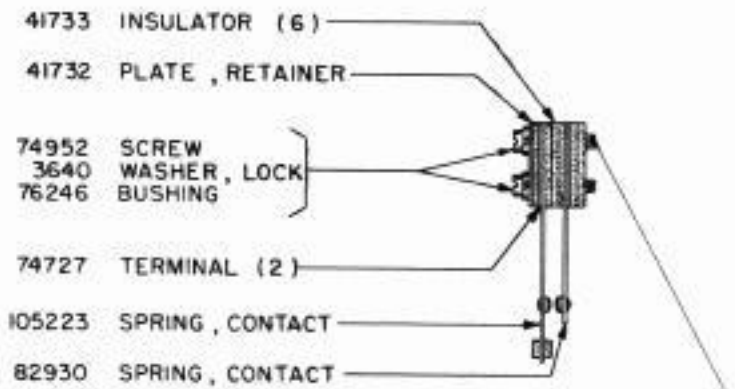

82917 SEND - RECEIVE - BREAK MECHANISM
(EXCLUDES PARTS MARKED (A))

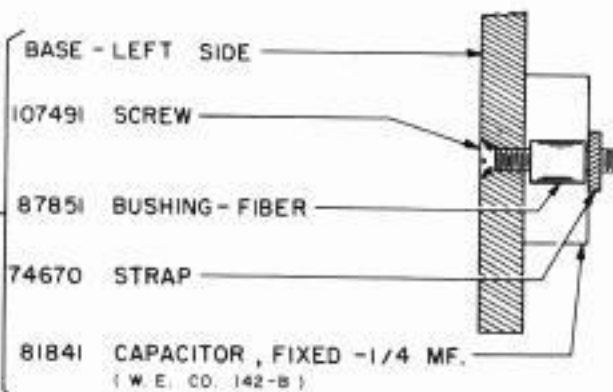

(B) 74817 LINE RELAY SPARK PROTECTION

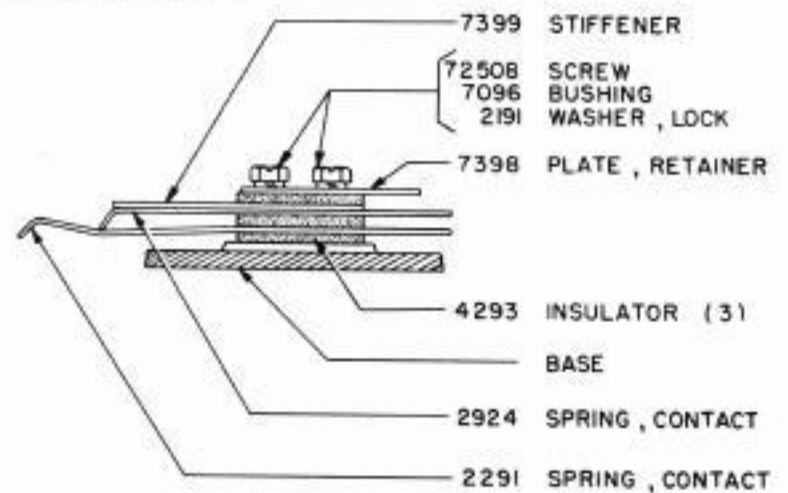

LINE CLOSING CONTACTS

(B) SEE PAGE I-2 FOR EXPLANATION

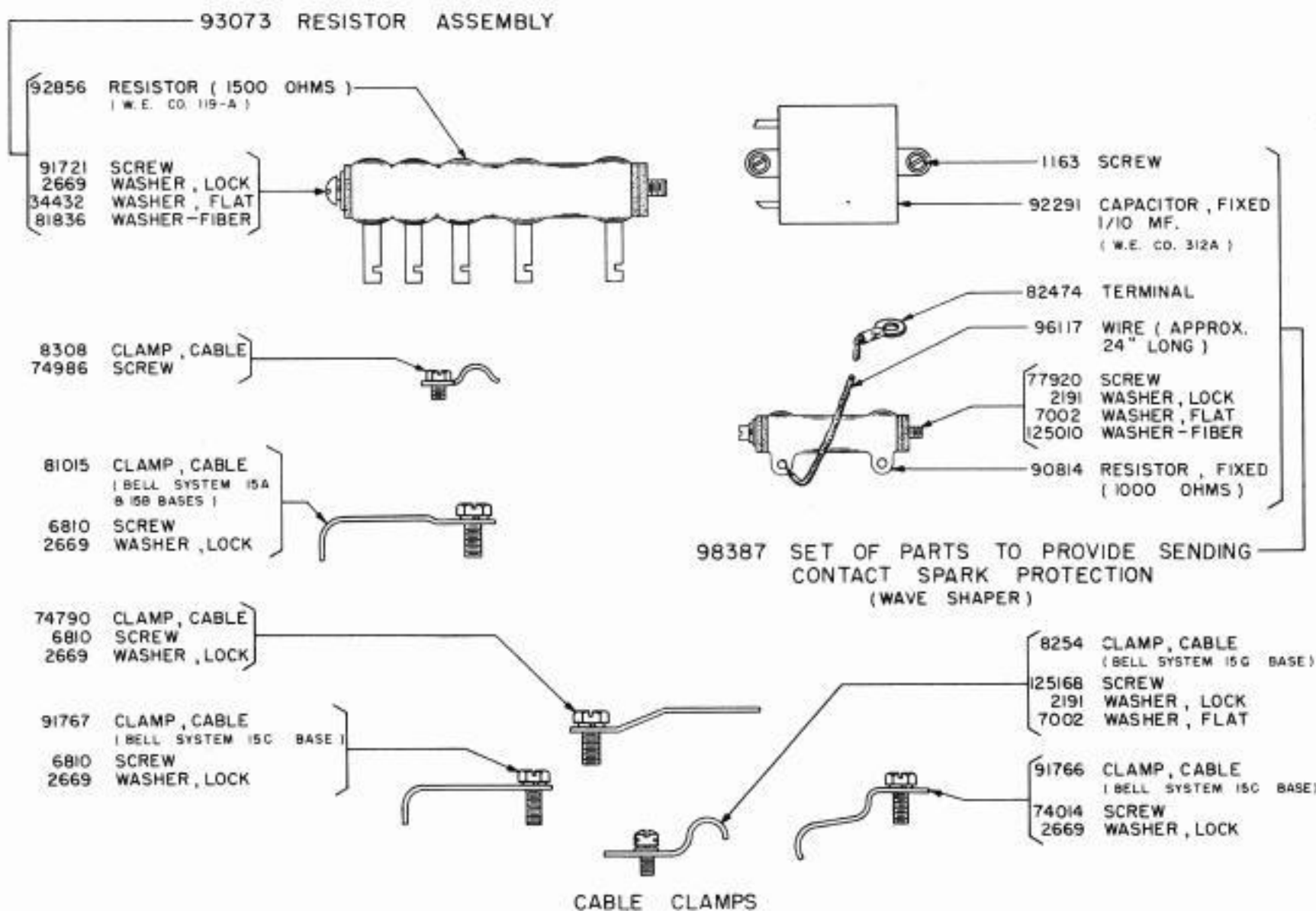
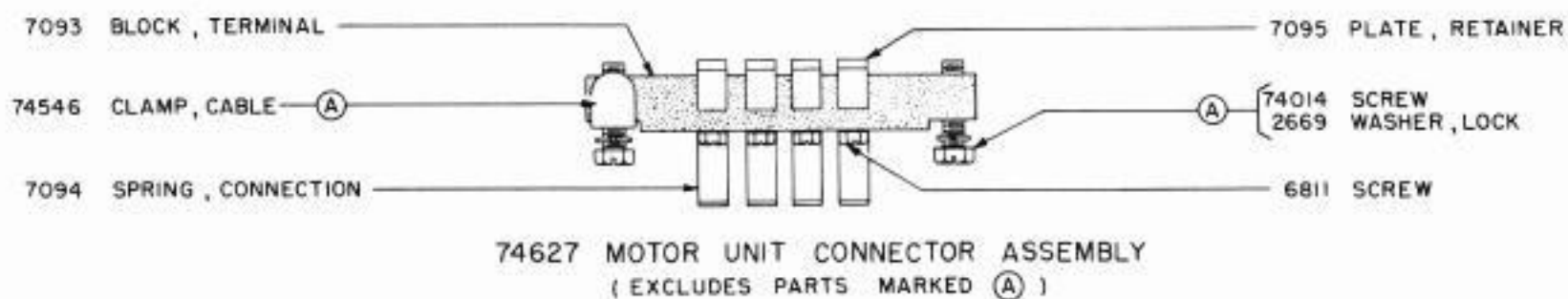
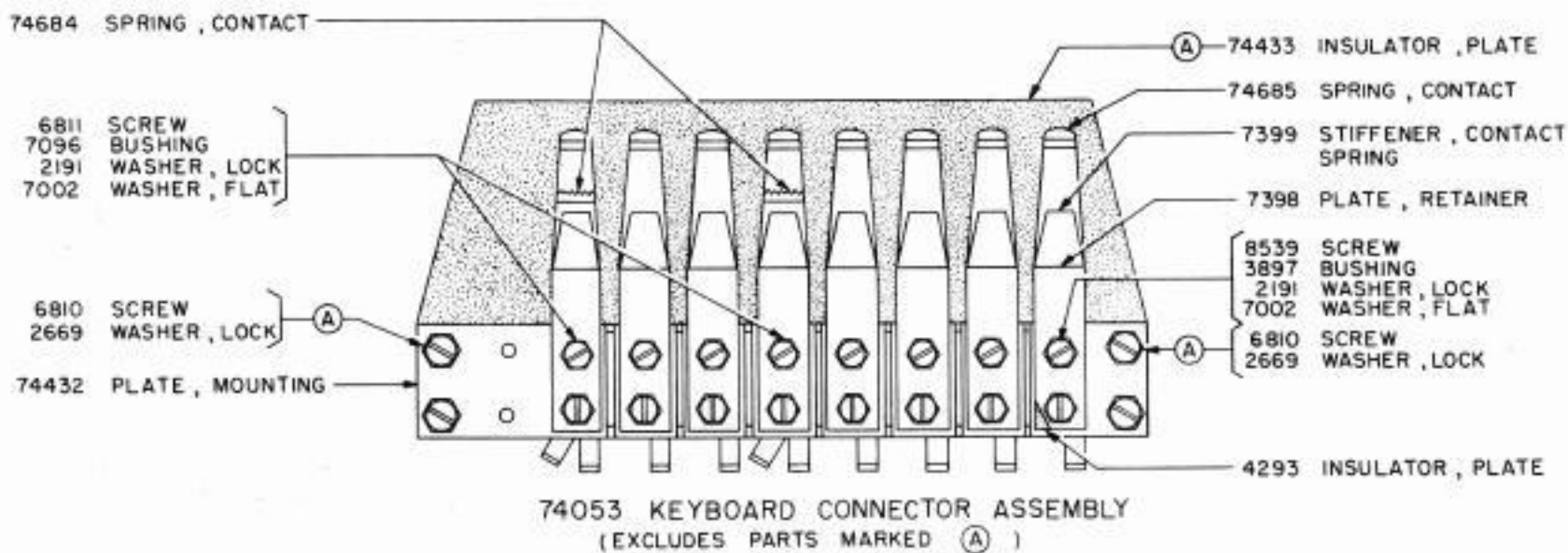

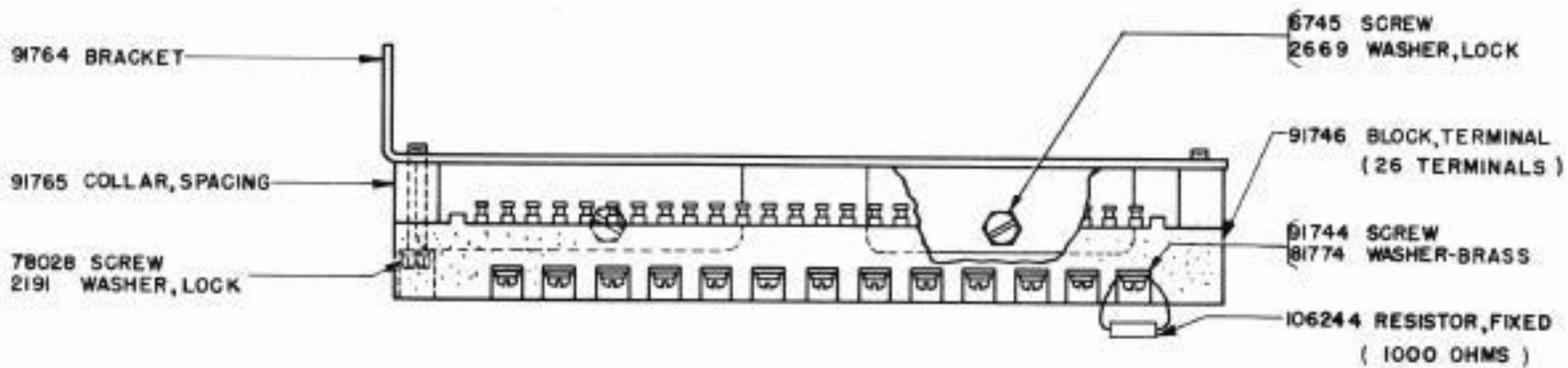
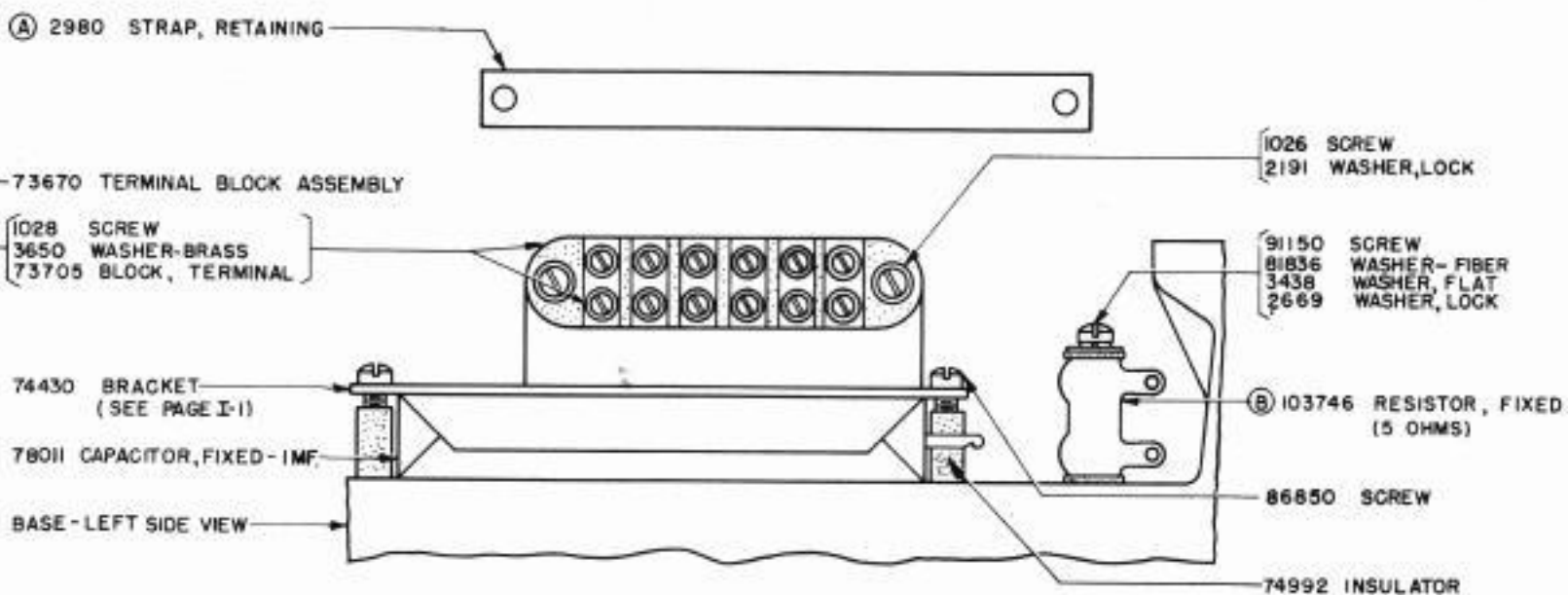
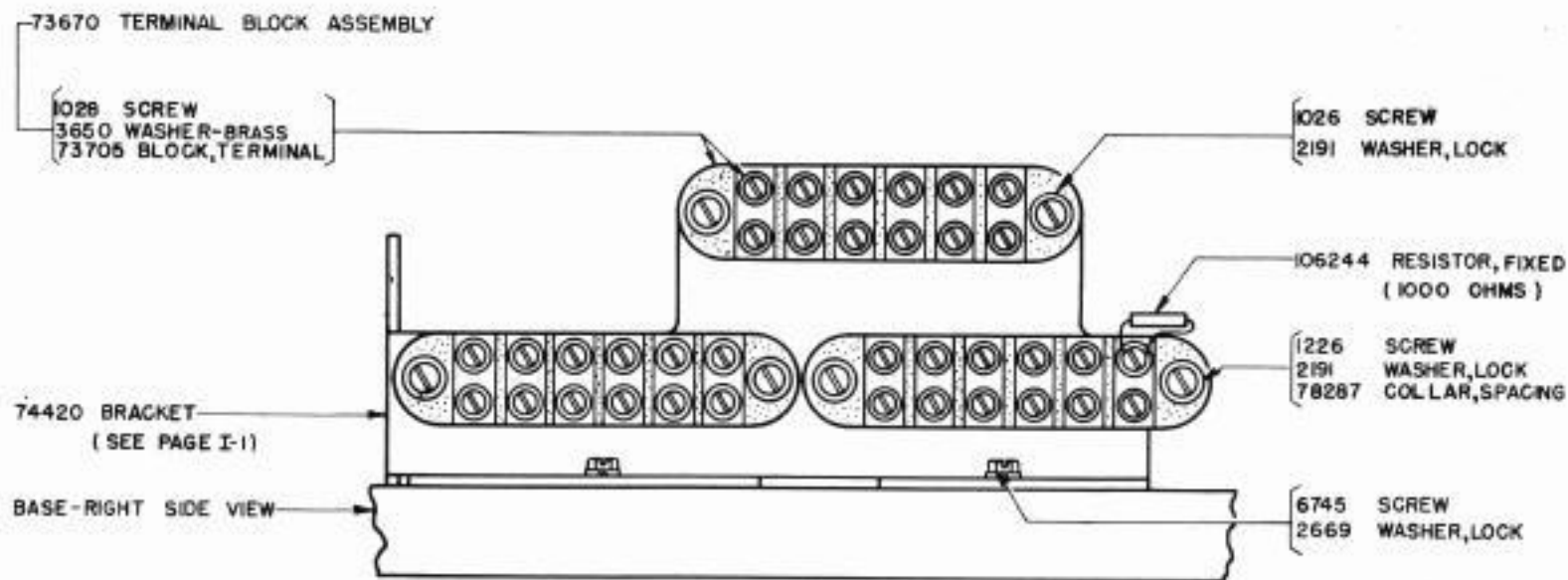

TERMINAL BLOCK PARTS

(A) (B) SEE SEC. III FOR EXPLANATION

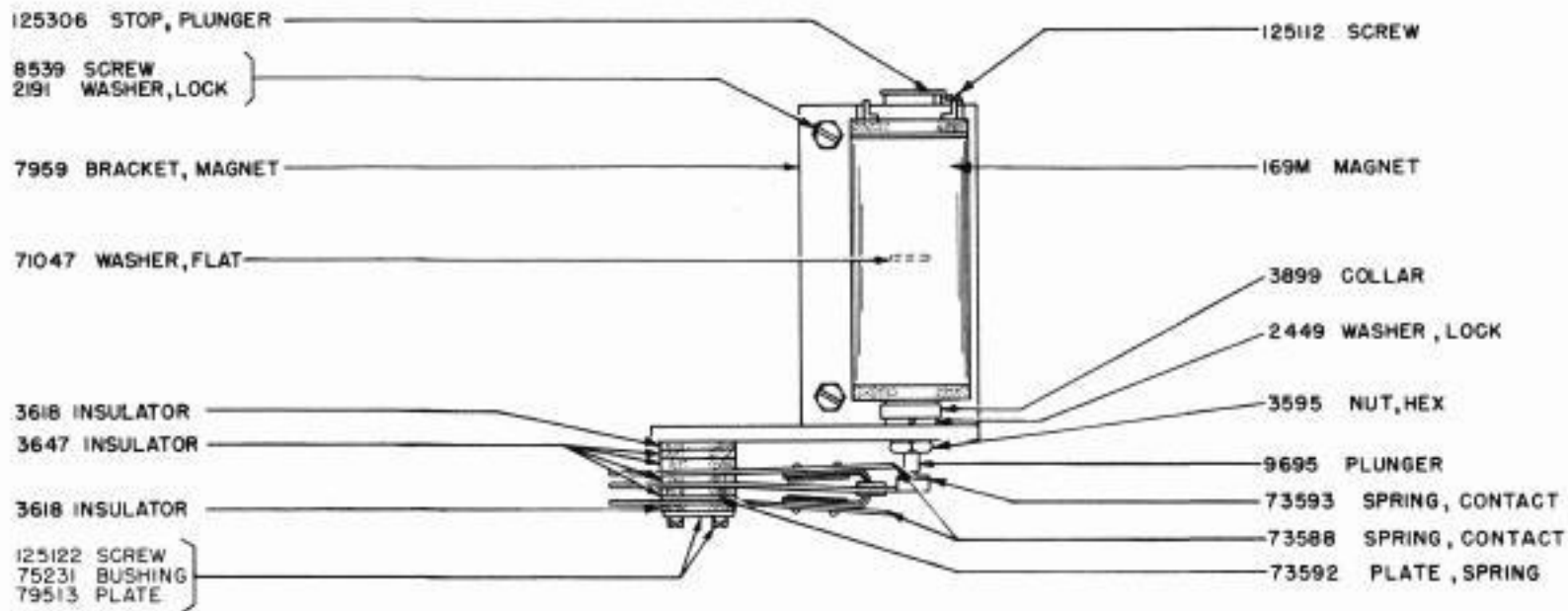

72484 MOTOR CONTROL RELAY

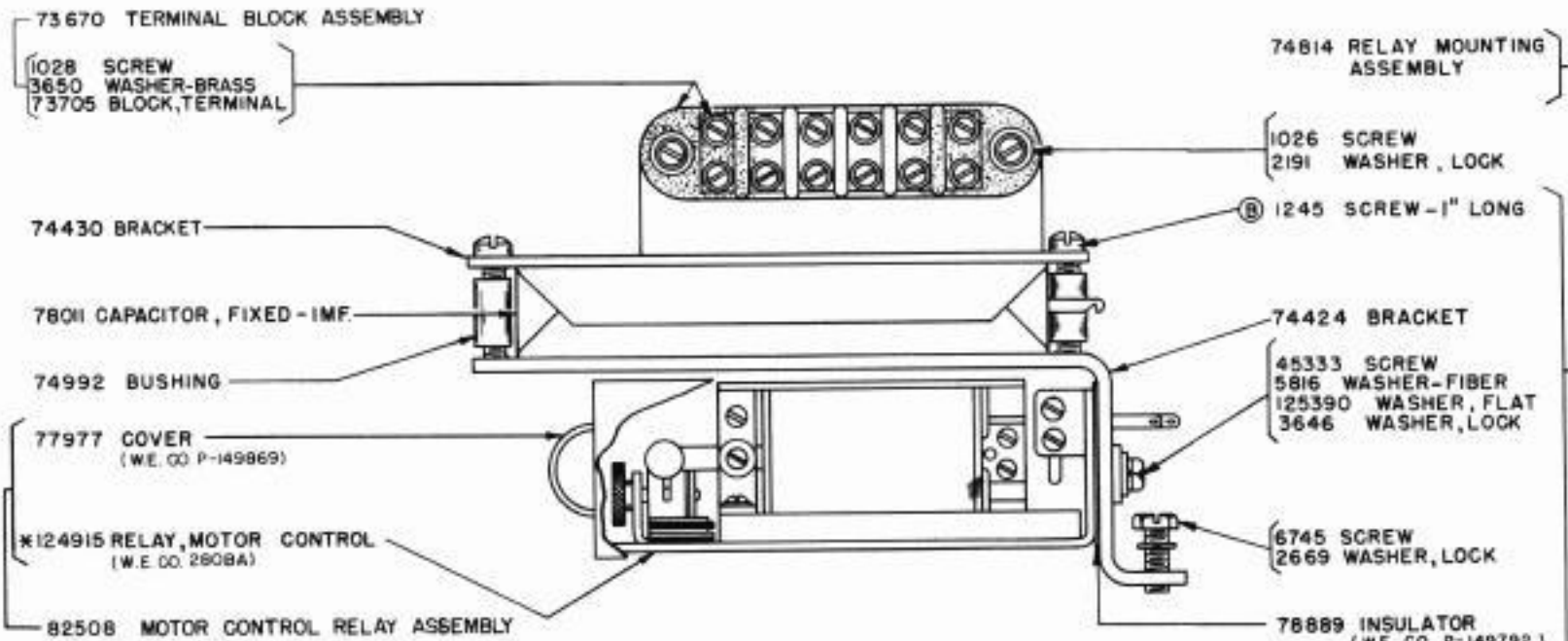

MOTOR CONTROL RELAY (POLARIZED)

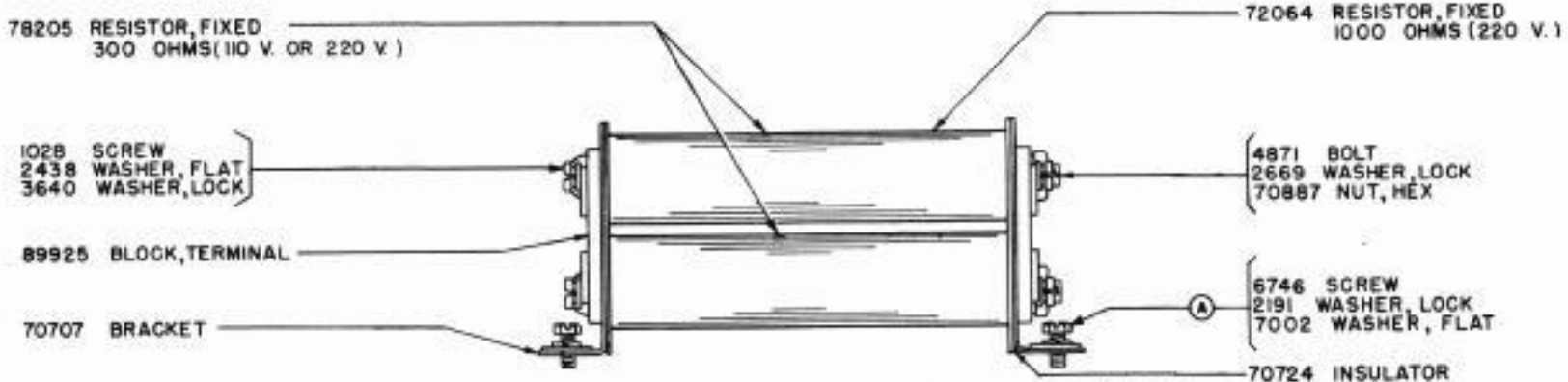

78206 RESISTOR ASSEMBLY: 150-300-600 OHMS (110 V.) (EXCLUDES PARTS MARKED (A))

82346 RESISTOR ASSEMBLY: 300-1000-1300 OHMS (220 V.) (EXCLUDES PARTS MARKED (A))

* FORMERLY 72818 (W.E. CO. 2064H)

(B) SEE SEC. IV FOR EXPLANATION

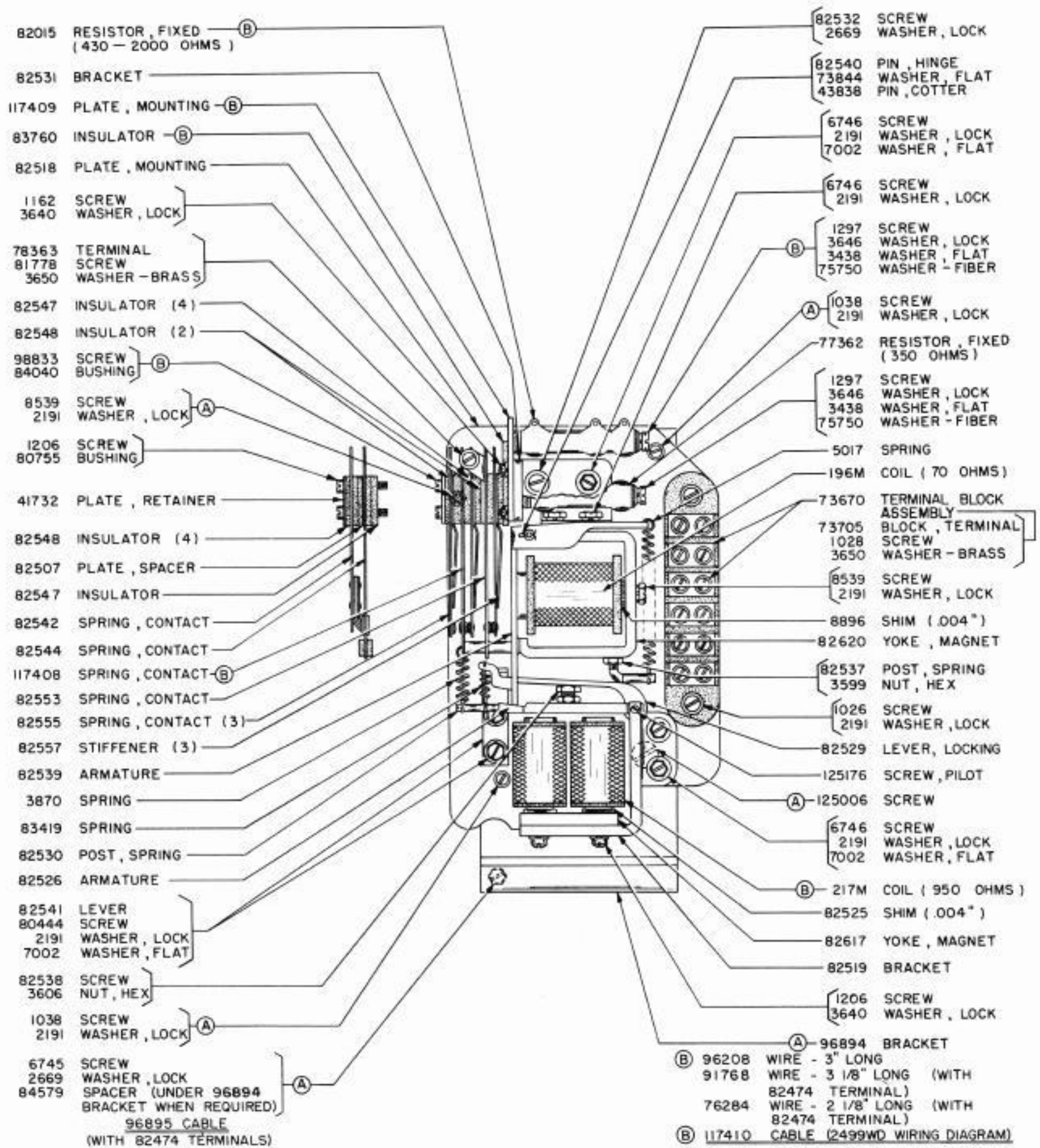

117746 SET OF PARTS FOR BASE

117745 SET OF PARTS TO PROVIDE ELECTRICAL MOTOR CONTROL
ON UPPER CASE "H" (.020 AMP. OR .060 AMP - POLAR OR NEUTRAL)
NOT USED IN THE BELL SYSTEM

97645 SET OF PARTS FOR TYPING UNIT (SHOWN ON PAGE I-8)
*117746 SET OF PARTS FOR BASE (SHOWN ABOVE)

*THE 117746 SET OF PARTS INCLUDES A 117747 MOTOR STOP ASSEMBLY CONSISTING
OF THE PARTS LISTED ABOVE, INCLUDING PARTS MARKED (B) AND EXCLUDING PARTS MARKED (A)

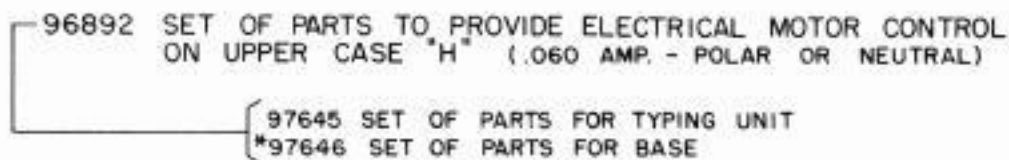
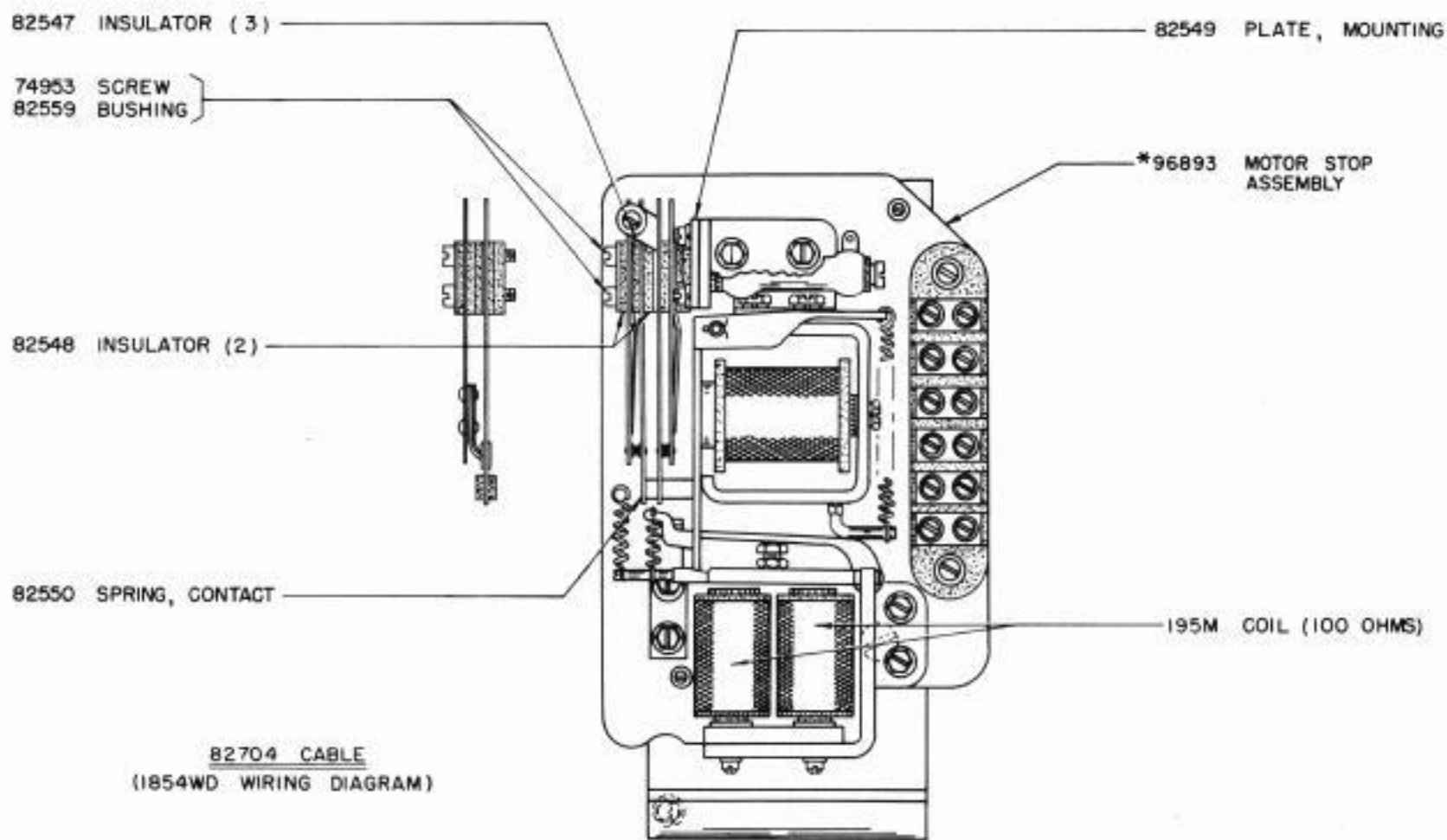
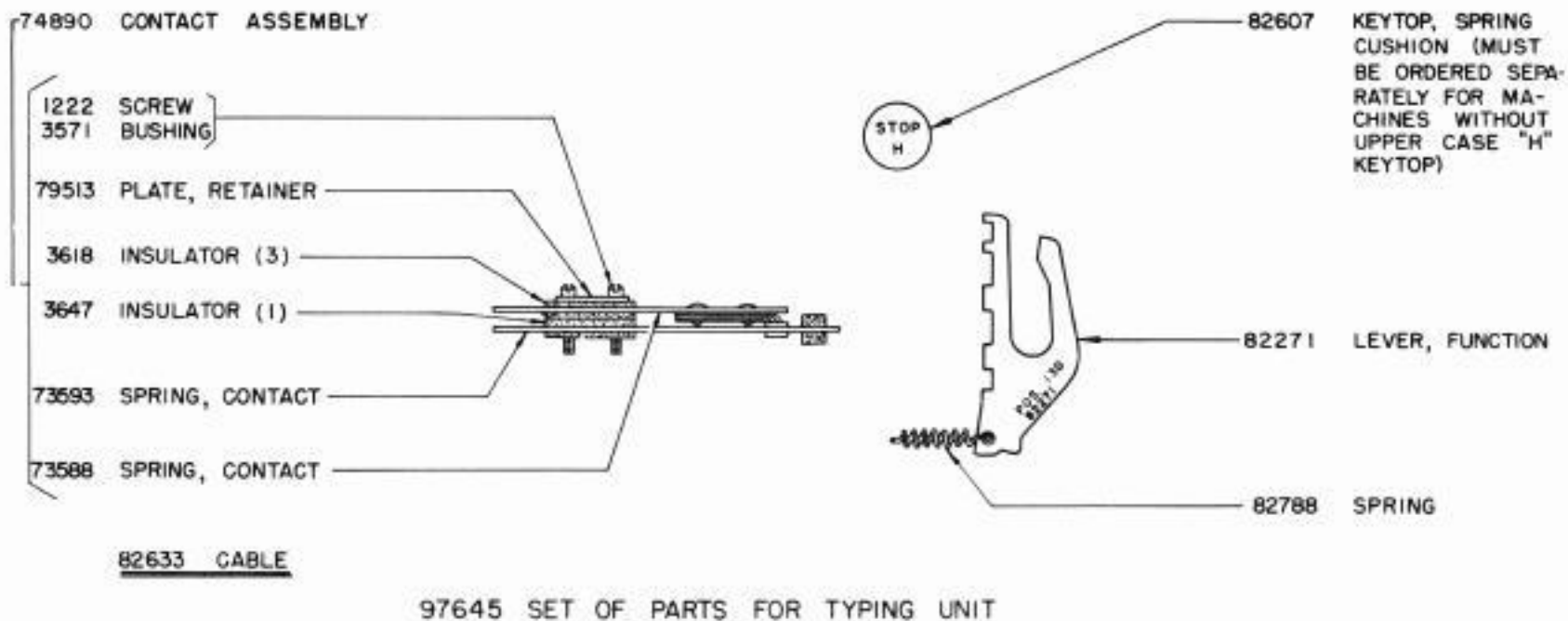

*THE 97646 SET OF PARTS INCLUDES A 96893 MOTOR STOP ASSEMBLY CONSISTING OF THE PARTS LISTED ABOVE AND ON PAGE I-7, EXCLUDING PARTS MARKED (A) AND (B)



74853 CORD, POWER

APPROXIMATELY 28 1/2 INCHES LONG, INCLUDES 72481 PLUG (2 PRONGS) AND 82474 TERMINALS.



89317 CORD, LINE

APPROXIMATELY 35 INCHES LONG, INCLUDES 73497 PLUG - RED (W.E. CO. 347A) AND 82474 TERMINALS.



89469 CORD, POWER

APPROXIMATELY 40 INCHES LONG, INCLUDES 92854 PLUG (2 PRONGS) AND 82474 TERMINALS.



8811 CORD, LINE

APPROXIMATELY 59 INCHES LONG, INCLUDES 73497 PLUG - RED (W.E. CO. 347A) AND 82474 TERMINALS.

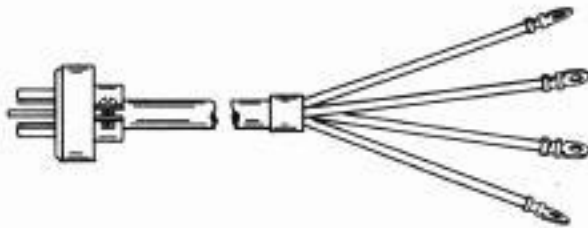

95050 CORD, POWER

APPROXIMATELY 40 INCHES LONG, INCLUDES 95063 PLUG (3 PRONGS) AND 82474 TERMINALS.



89472 CORD, LINE

APPROXIMATELY 41 INCHES LONG, INCLUDES 73497 PLUG - RED (W.E. CO. 347A) AND 102100 TERMINALS



8809 CORD, POWER

APPROXIMATELY 63 INCHES LONG, INCLUDES 125457 PLUG (2 PRONGS) AND 82474 TERMINALS.

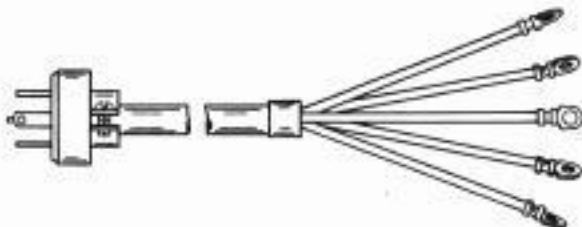

95052 CORD, POWER

APPROXIMATELY 40 INCHES LONG, INCLUDES 95064 PLUG (4 PRONGS) AND 82474 TERMINALS.



89438 CORD, LINE

APPROXIMATELY 41 INCHES LONG, INCLUDES 103236 PLUG - BLACK AND 102100 TERMINALS.

POWER AND LINE CORD ASSEMBLIES



- 55080 BEZEL
- 87182 DISK-CELLULOID
- 125463 PACKING

- 1169 SCREW
- 2191 WASHER, LOCK

- 74589 TERMINAL BLOCK ASSEMBLY
INCLUDES

- 74569 BLOCK, TERMINAL

- 101456 SCREW
- 125229 NUT, HEX

- 96883 TERMINAL

- 74609 SHAFT, SPACER BAR
- 3599 NUT, HEX

- 2378 LEVER, SPACER KEY

- 72643 SCREW, SHOULDER

- 74528 LOOP, SPACER BAR

- 6746 SCREW
- 2191 WASHER, LOCK

- 7334 POST
- 2191 WASHER, LOCK
- 3598 NUT, HEX

- 74749 PLATE, STOP
- 6746 SCREW
- 2191 WASHER, LOCK
- 7002 WASHER, FLAT

- 2525 GUIDE, KEY LEVER-
FRONT

- 6746 SCREW
- 2191 WASHER, LOCK

- 74525 SCREW, THUMB
- 74594 RING, RETAINING

- (A) 9210 LEVER, KEY (WITH DISK)
- (B) 72984 LEVER, KEY

- (A) 9209 LEVER, KEY (WITH DISK)
- (B) 72983 LEVER, KEY

- (A) 74762 LEVER, KEY (WITH DISK)
- (B) 7482 LEVER, KEY

- 85098 BAR, SPACE

TOP VIEW

- 72545 POST
- 2191 WASHER, LOCK
- 3598 NUT, HEX

- 74601 BAR, UNIVERSAL

- 70177 SCREW, PILOT
- 3606 NUT, HEX

- 93737 SHIM (.004")
- 3458 SHIM (.015")

- 8539 SCREW
- 2191 WASHER, LOCK

- 7396 BRACKET—LEFT
- 7397 BRACKET—RIGHT

- 9203 BRACKET (WITH ROLLERS)

- 2528 PLATE, SPRING

- 80392 SPRING, SPACER
KEY LEVER

- 74691 RESISTOR (800-800 OHMS) (C)

- 1297 SCREW
- 75750 WASHER-FIBER
- 3438 WASHER, FLAT
- 3646 WASHER, LOCK

- 2191 WASHER, LOCK
- 3598 NUT, HEX

- 74610 SHAFT, KEY LEVER

- 2663 BUMPER-RUBBER

- 2574 UPSTOP

- 1268 SCREW

- 74590 PLATE

- 74581 BAR, SELECTOR NO. 1
- 74582 BAR, SELECTOR NO. 2
- 74583 BAR, SELECTOR NO. 3
- 74584 BAR, SELECTOR NO. 4
- 74585 BAR, SELECTOR NO. 5

- 71449 GUIDE, KEY LEVER-
REAR

- 6746 SCREW
- 2191 WASHER, LOCK

- 74986 SCREW
- 2191 WASHER, LOCK

- (C) 82866 RESISTOR, FIXED
(800-3700 OHMS)

- (C) 1297 SCREW
- (C) 75750 WASHER-FIBER
- (C) 3438 WASHER, FLAT
- (C) 3646 WASHER, LOCK

- 2565 SPRING, KEY LEVER

BOTTOM VIEW

KEYBOARD

FOR KEYTOPS SEE CHART SHOWN ON PAGE I-39

(A) FOR SPRING CUSHION KEYTOPS

(B) FOR CELLULOID KEYTOPS

(C) PARTS ARE USED WITH LOCAL TEST KEY
(SEE PAGE I-13 FOR ADDITIONAL PARTS)

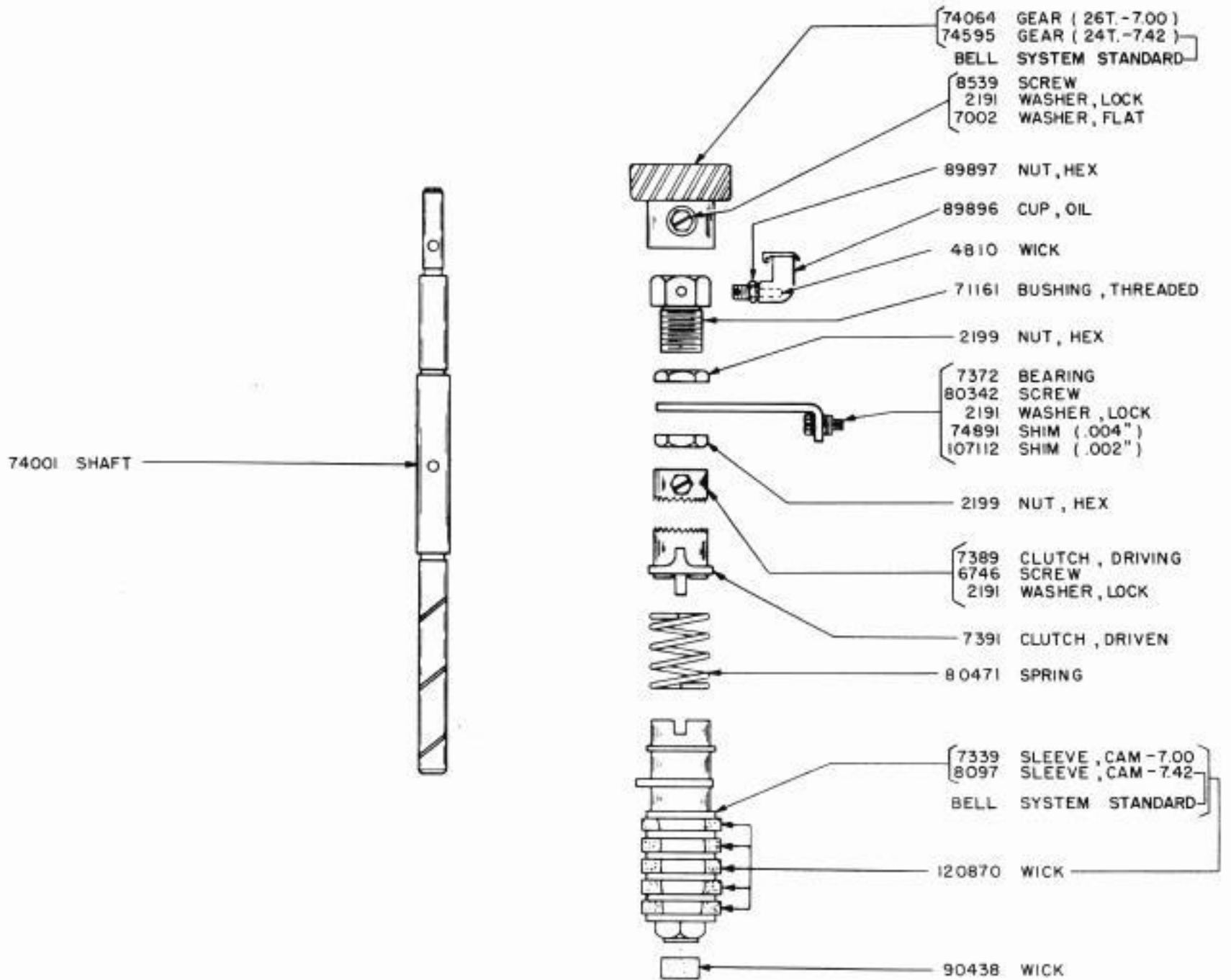
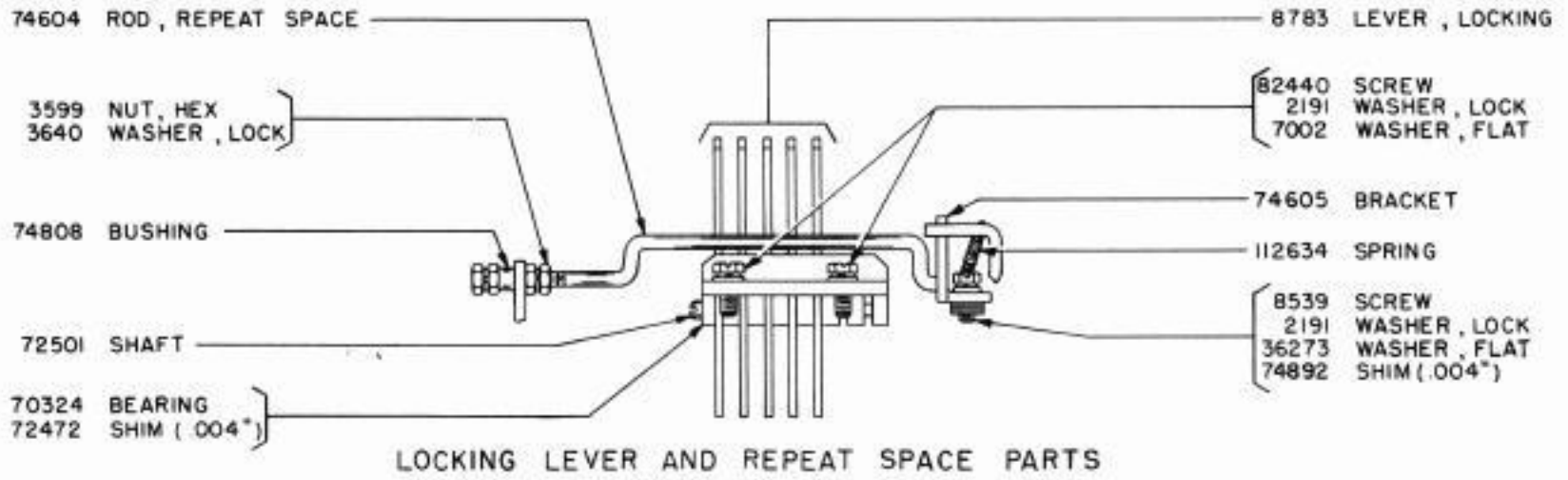

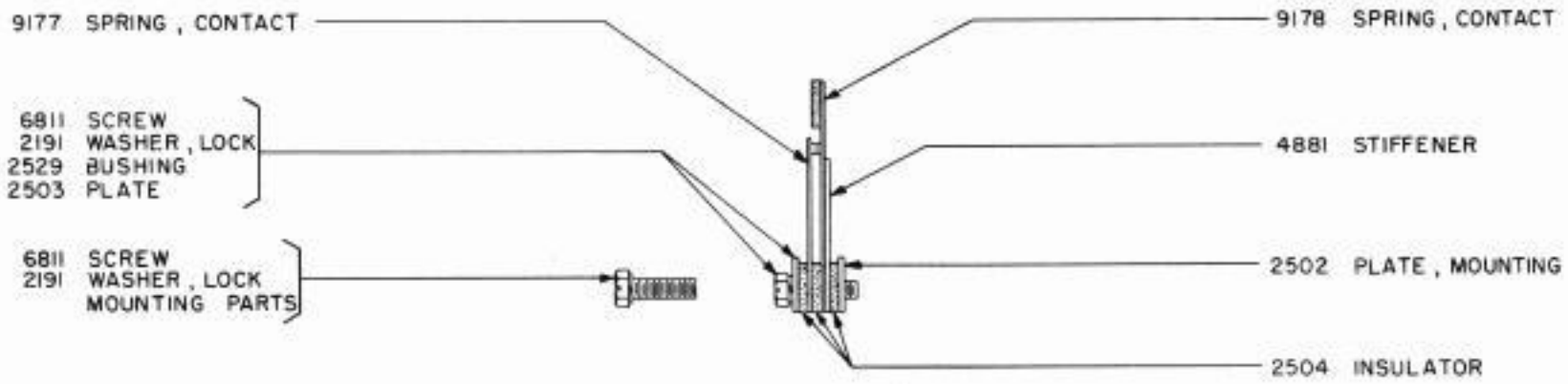

7381 CONTACT MOUNTING ASSEMBLY - LESS MOUNTING PARTS

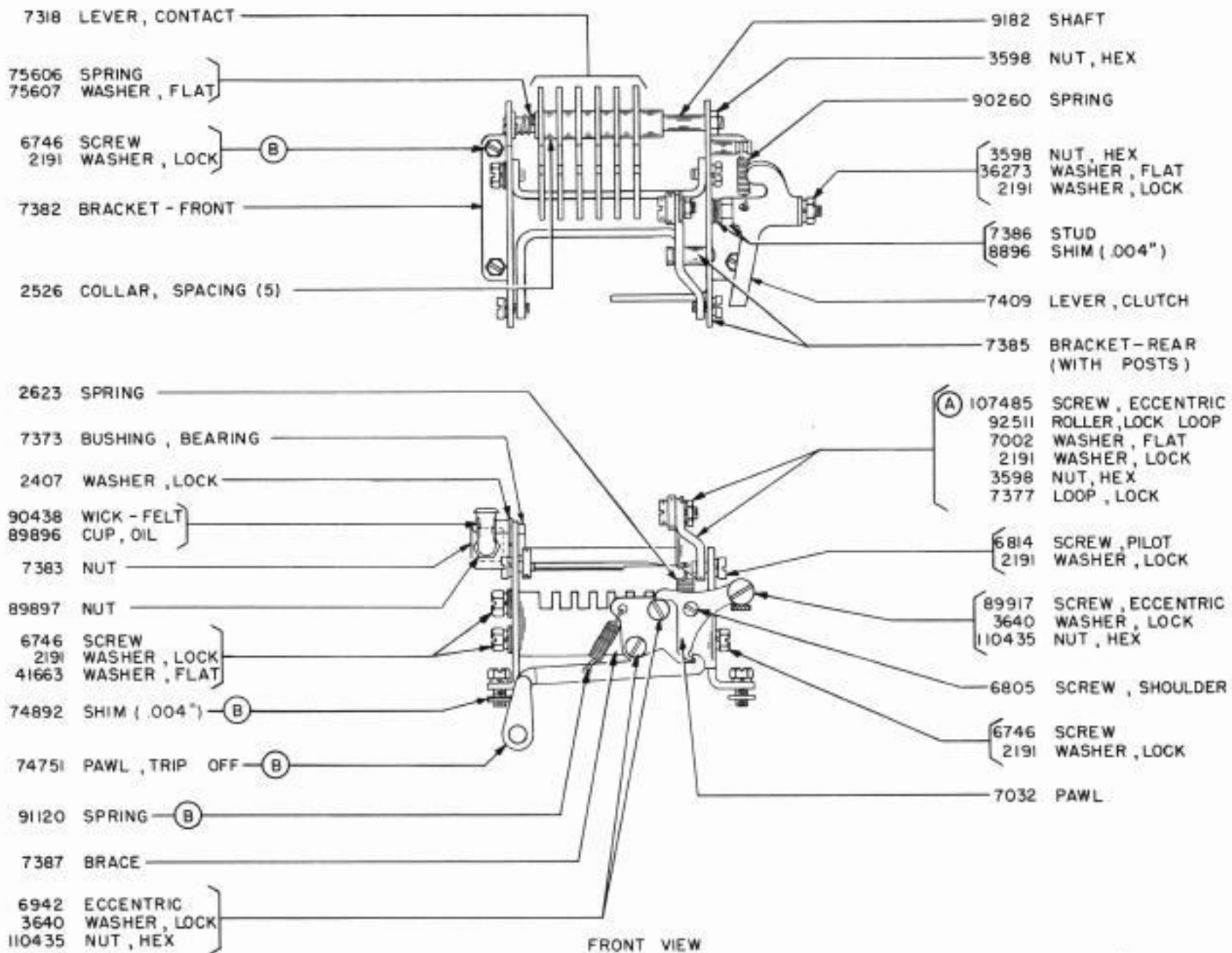

74690 TRANSMITTER MECHANISM (INCLUDES 7381 CONTACT MOUNTING ASSEMBLY)
(EXCLUDES PARTS MARKED (B))

(A) SEE SEC. IV FOR EXPLANATION

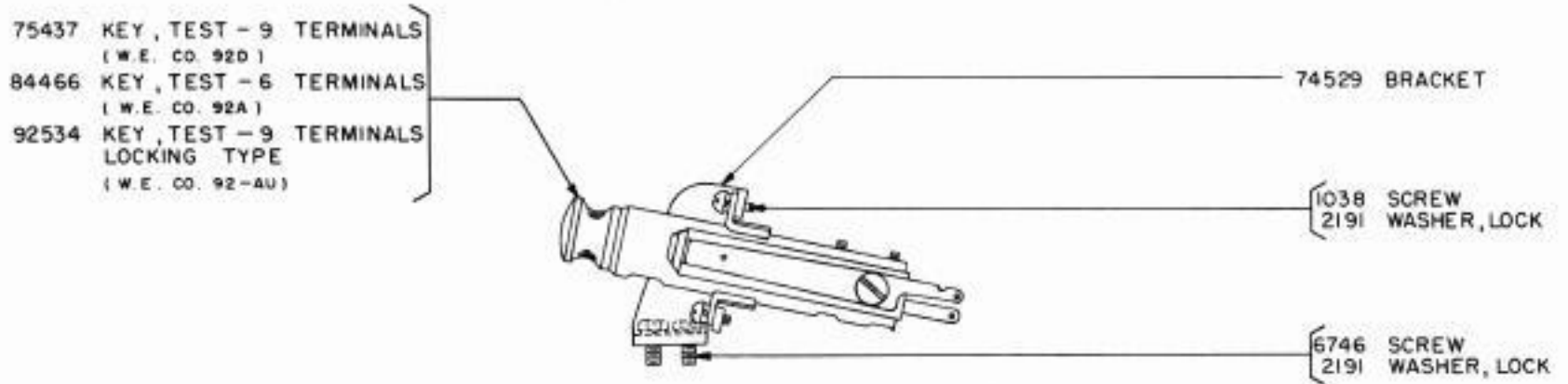

LINE TEST KEY - LOCKING AND NON-LOCKING (PUSH TYPE)

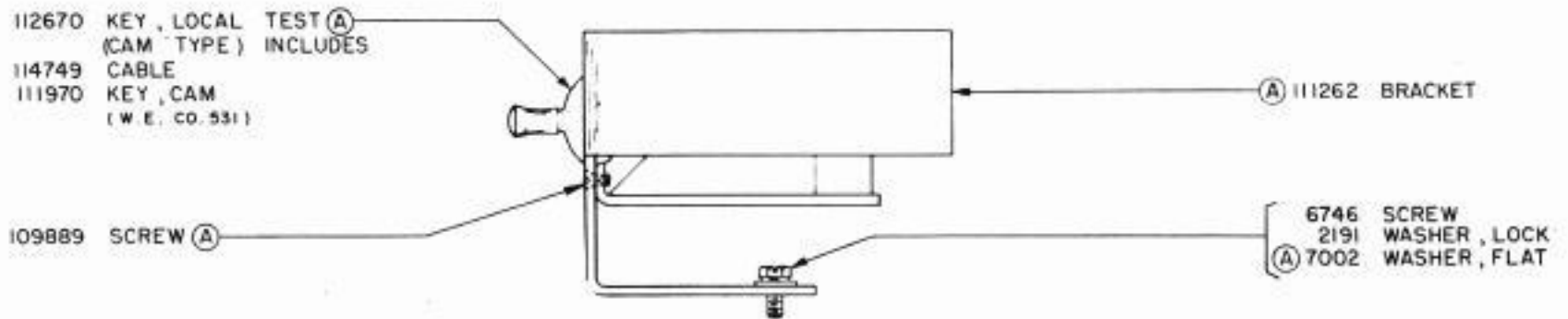

112549 SET OF PARTS TO PROVIDE LOCAL TEST ON KEYBOARD

(SEE PAGE I-10 FOR ADDITIONAL PARTS MARKED (C))

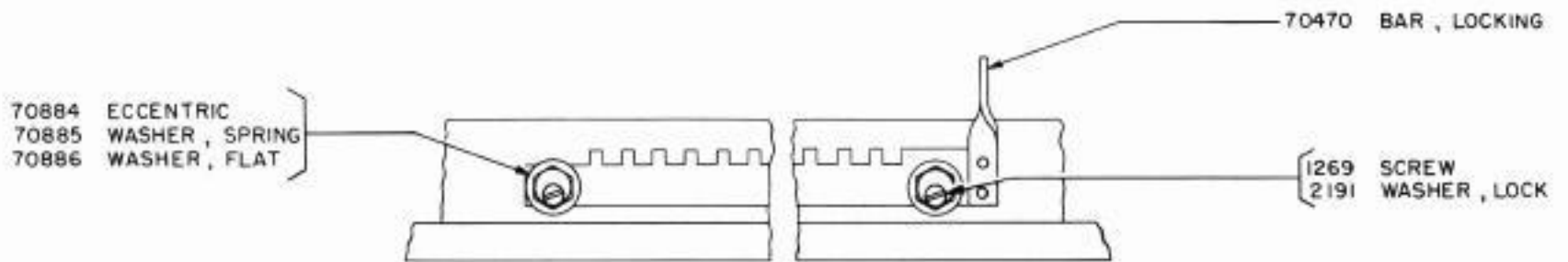

MANUAL KEYLEVER

(A) 106938 SET OF PARTS TO CONVERT THE PUSH TYPE TEST KEY TO THE CAM TYPE TEST KEY.

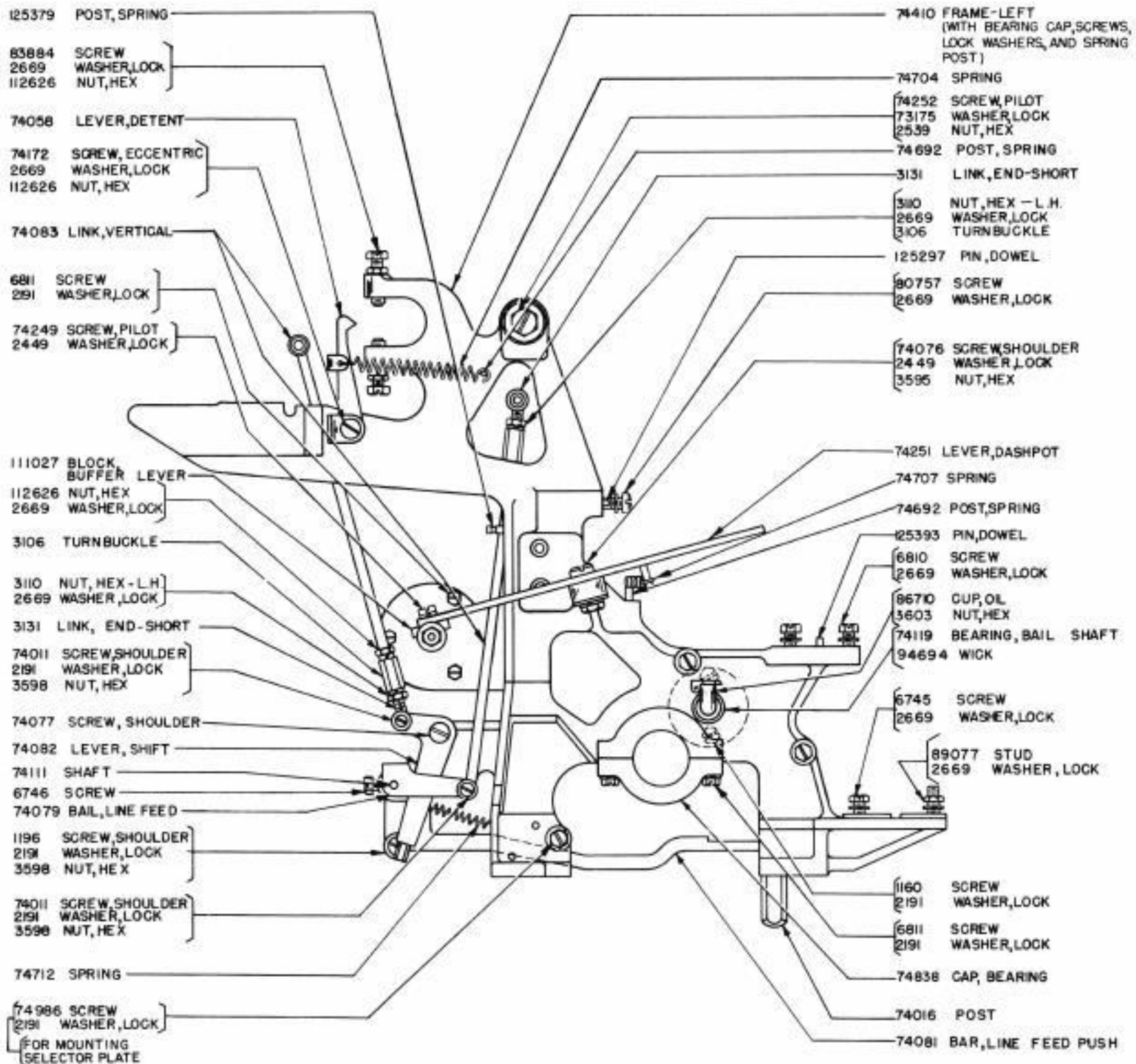

LEFT SIDE FRAME PARTS

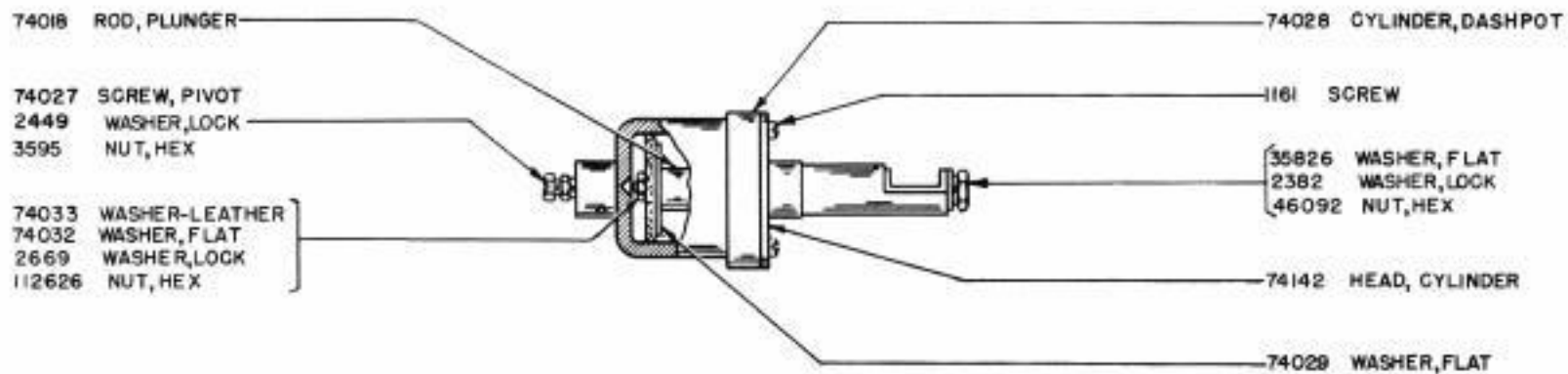

74282 DASHPOT ASSEMBLY

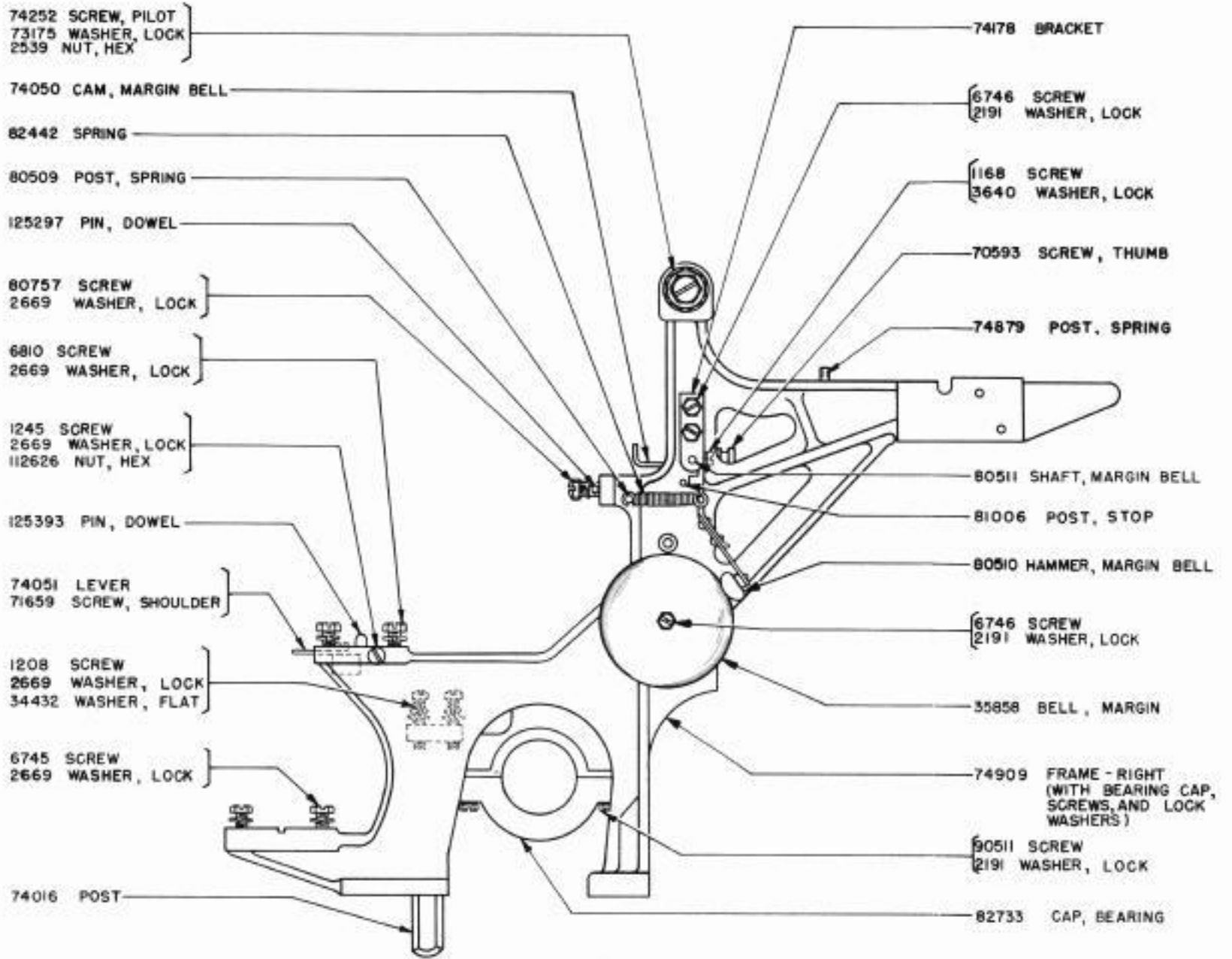

RIGHT SIDE FRAME PARTS

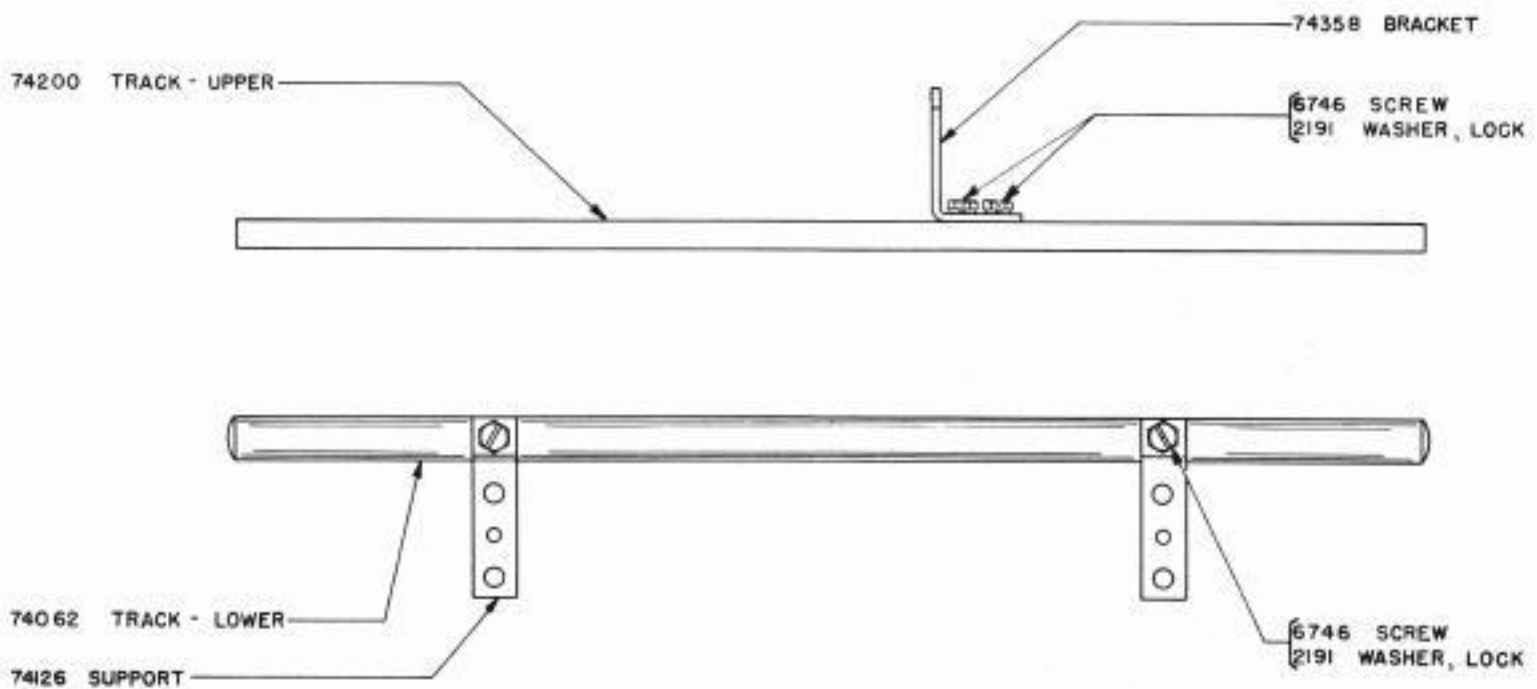

TYPE BAR CARRIAGE TRACKS

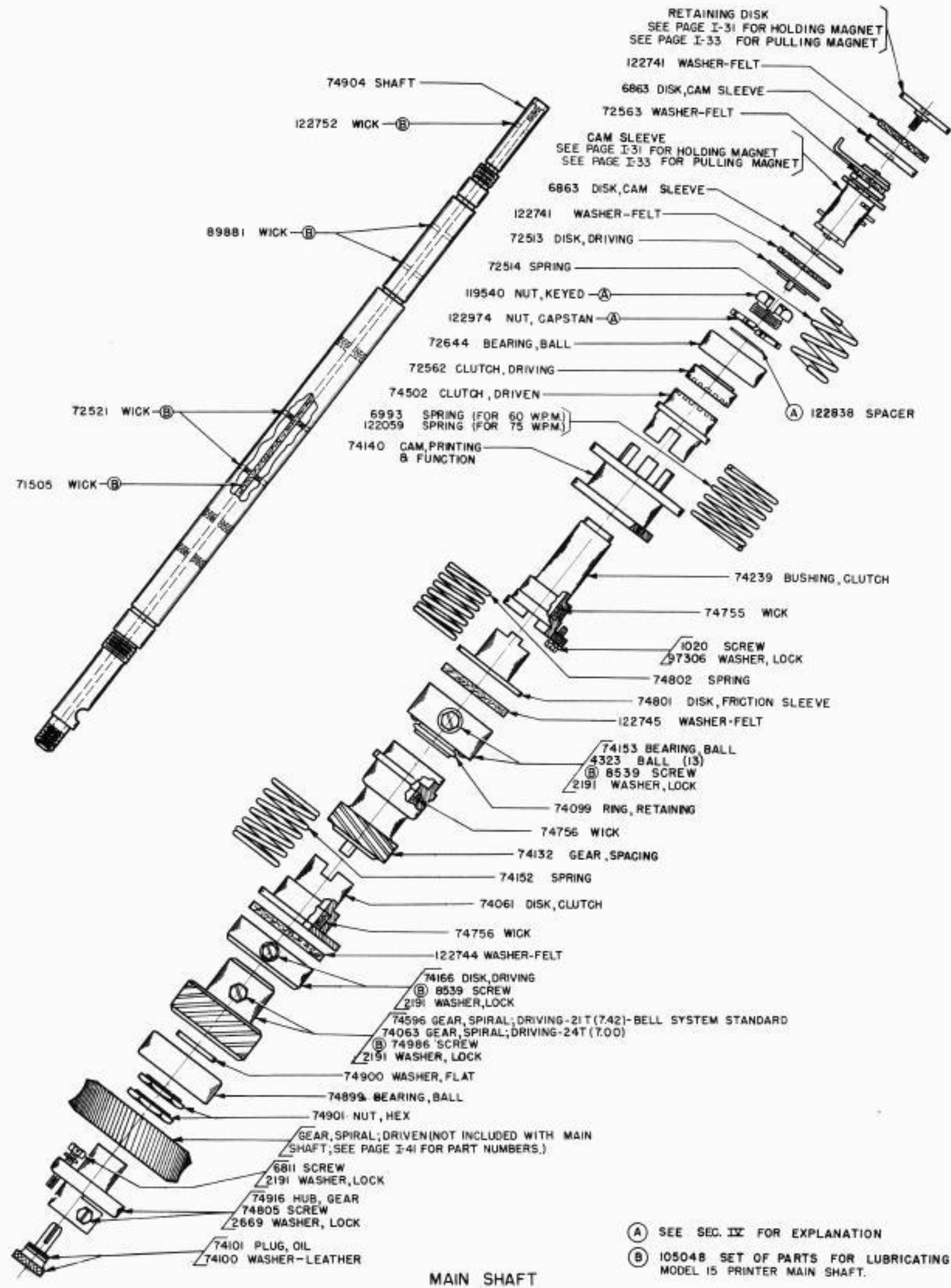

- (A) SEE SEC. IX FOR EXPLANATION
- (B) 105048 SET OF PARTS FOR LUBRICATING MODEL 15 PRINTER MAIN SHAFT.

MAIN SHAFT

ORIGINAL

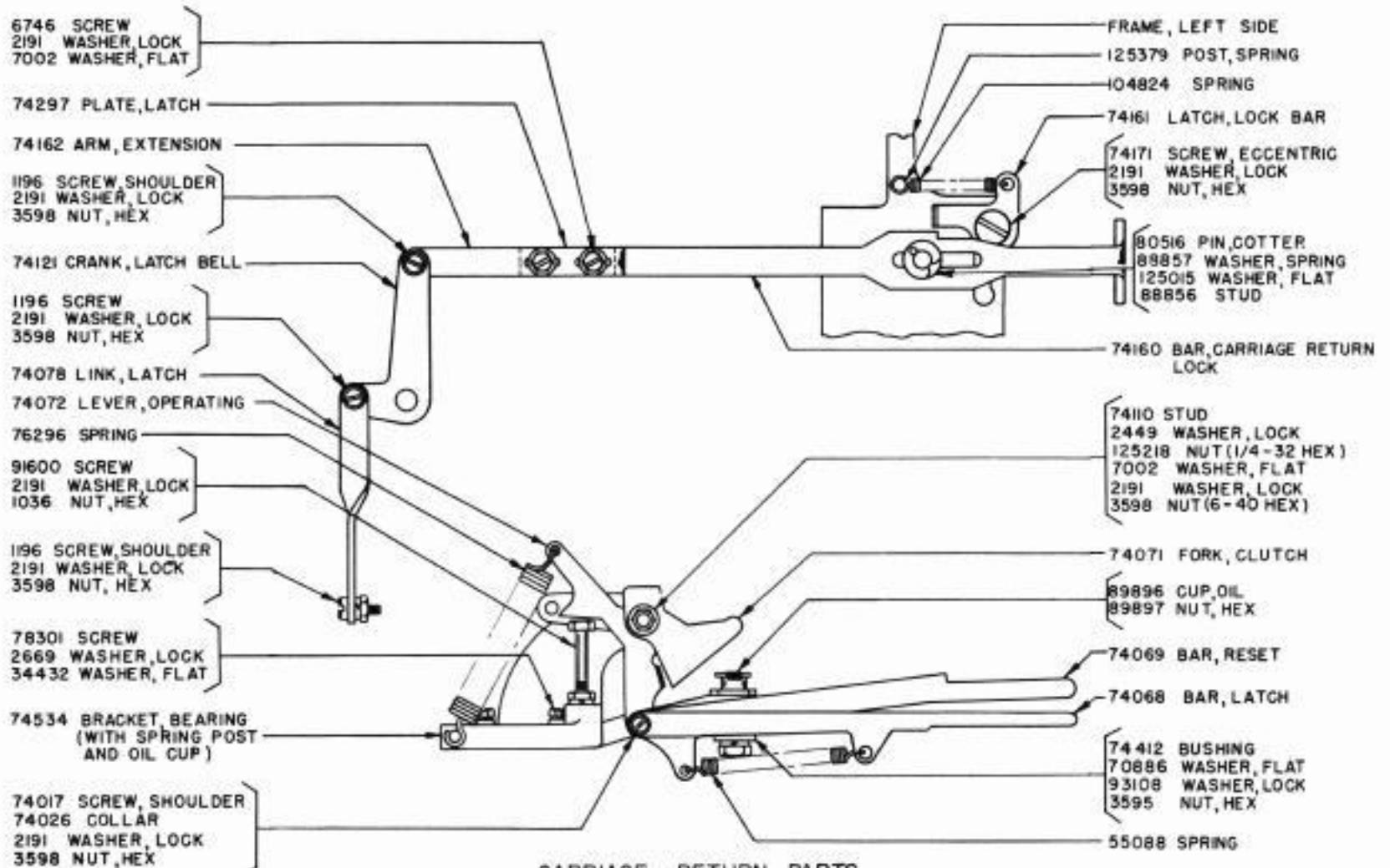

CARRIAGE RETURN PARTS

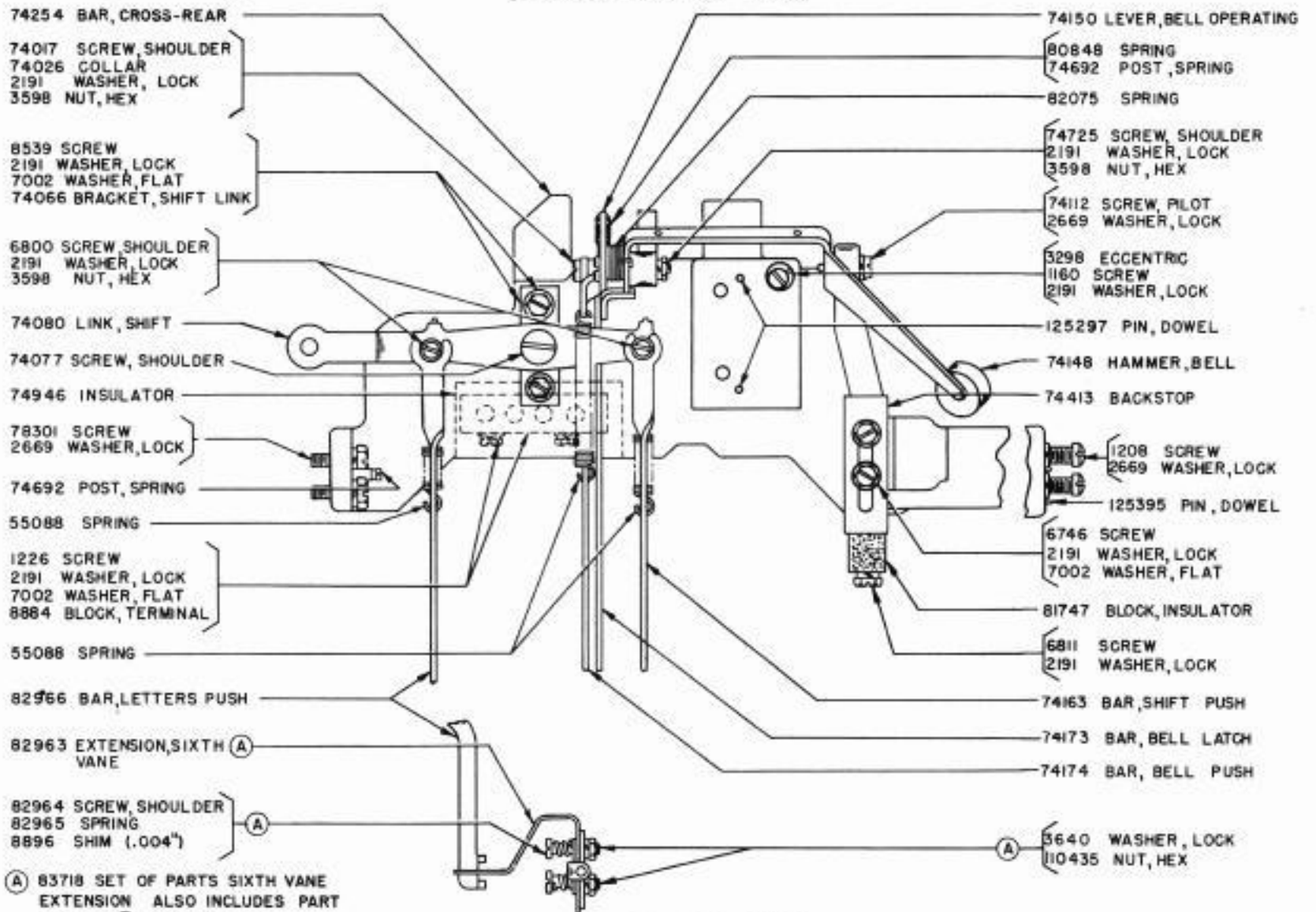

REAR CROSS BAR PARTS

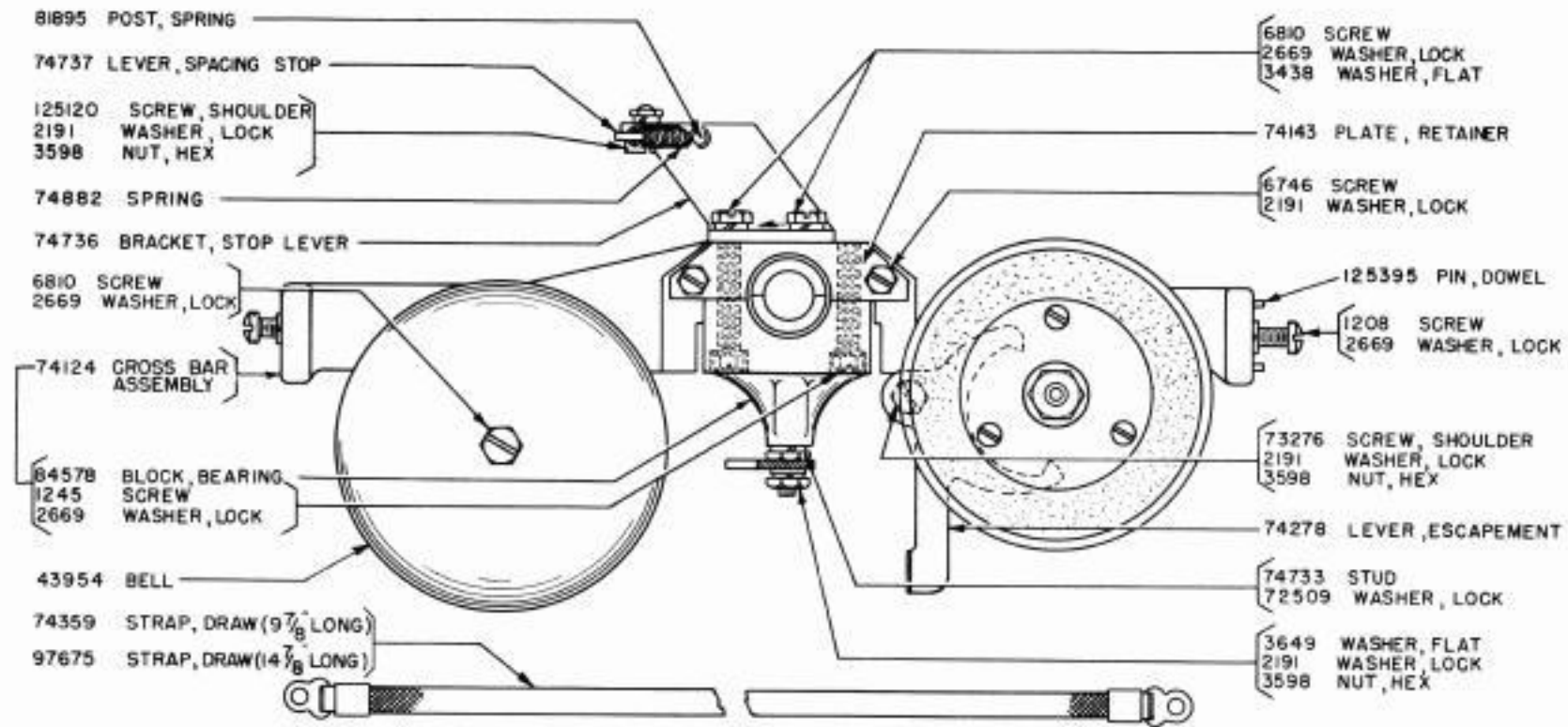

SPACING CROSS BAR PARTS

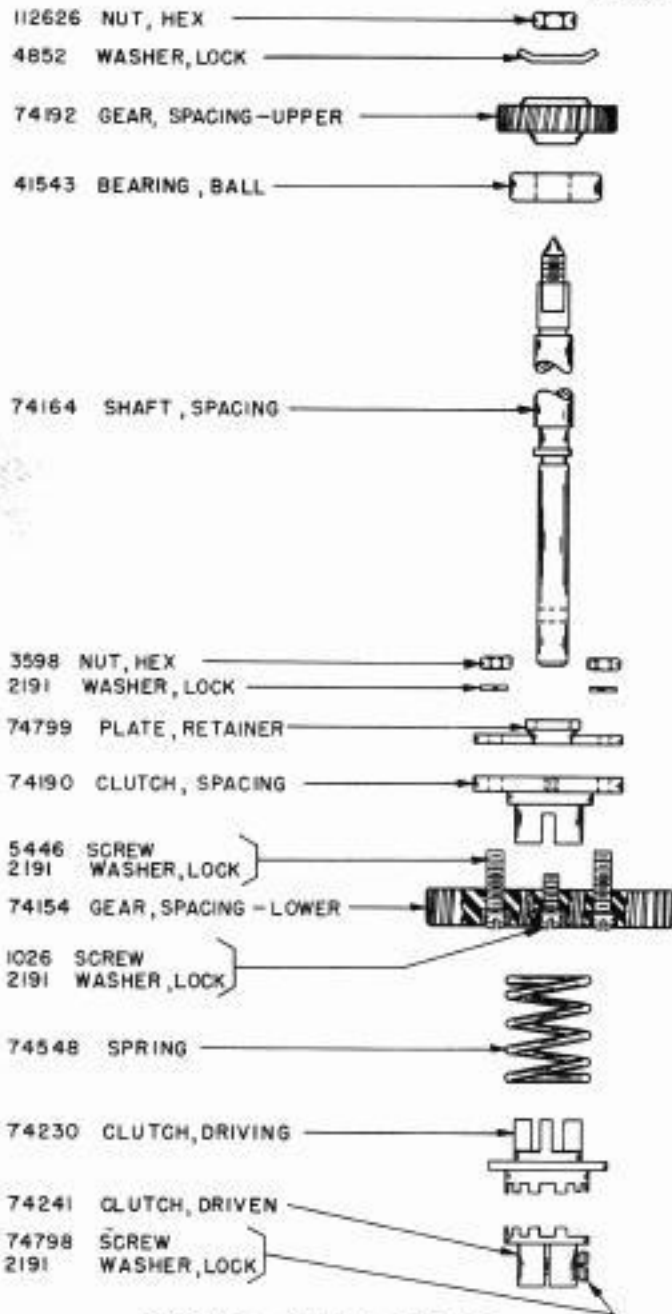

SPACING SHAFT PARTS

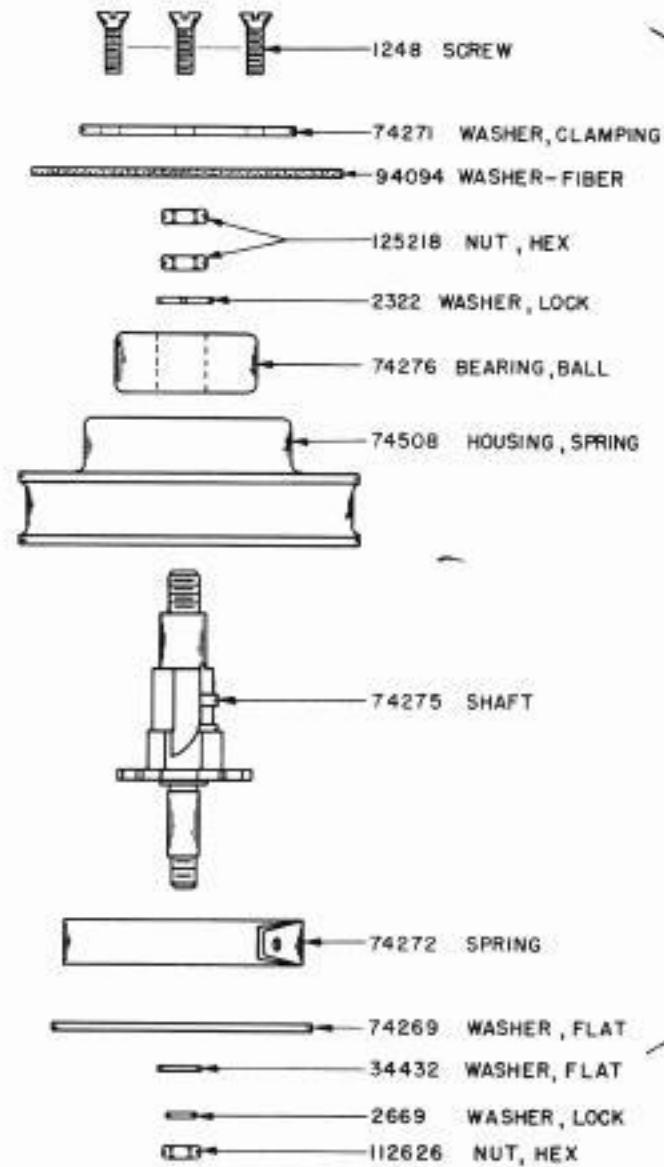

74300 SPRING DRUM ASSEMBLY

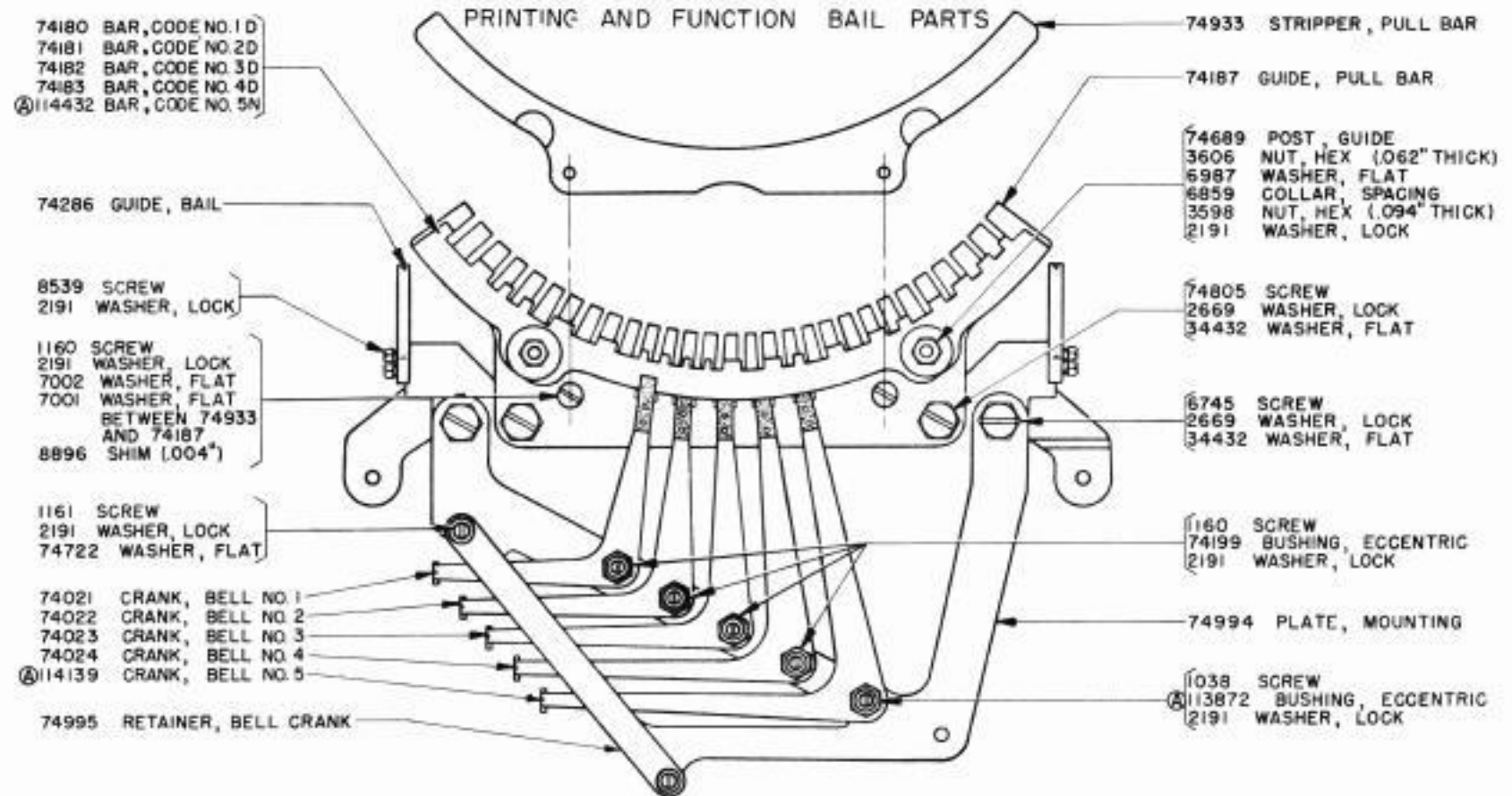
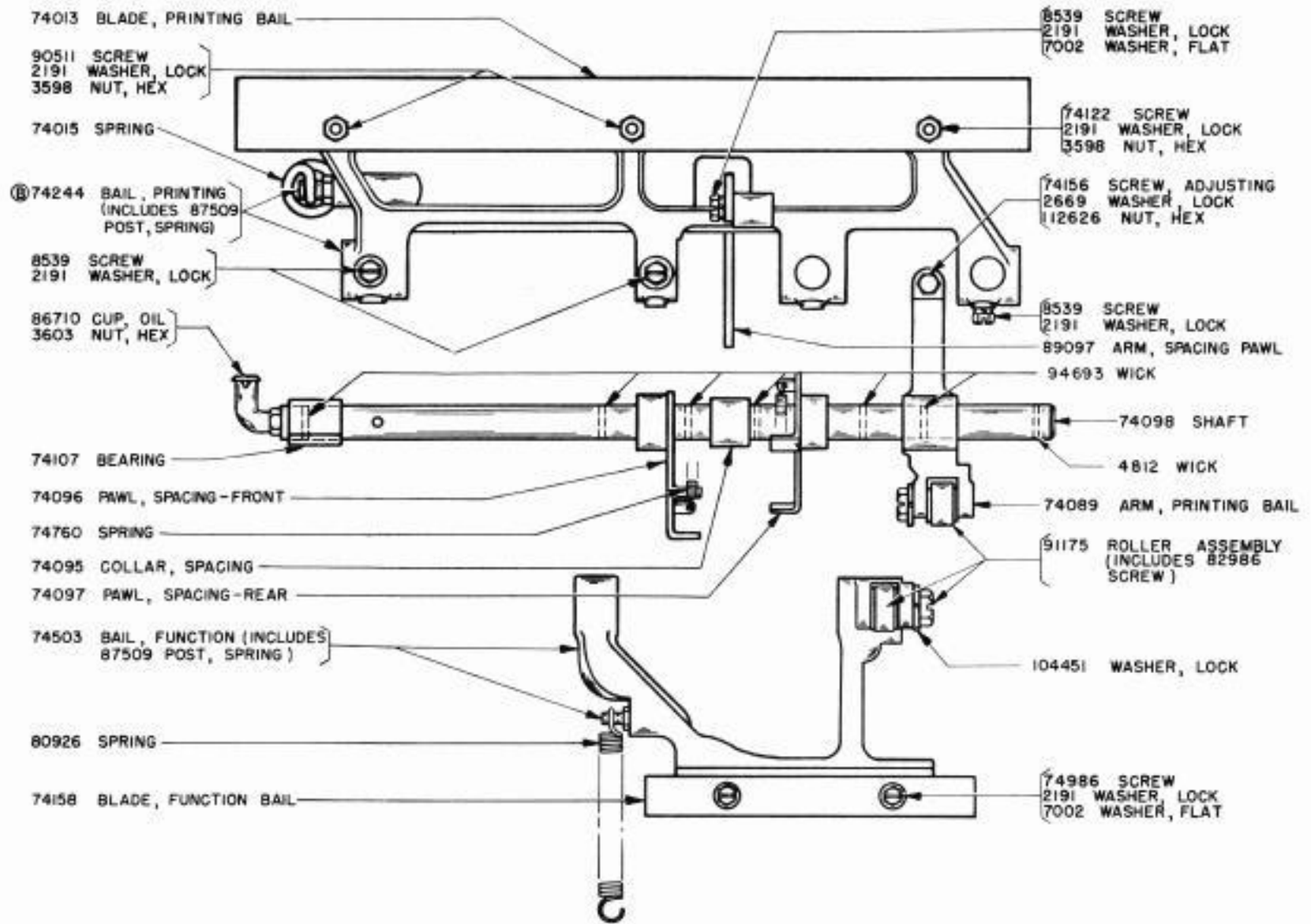

Ⓐ & ⓑ SEE SEC. IV FOR EXPLANATION

CODE BAR AND BELL CRANK PARTS

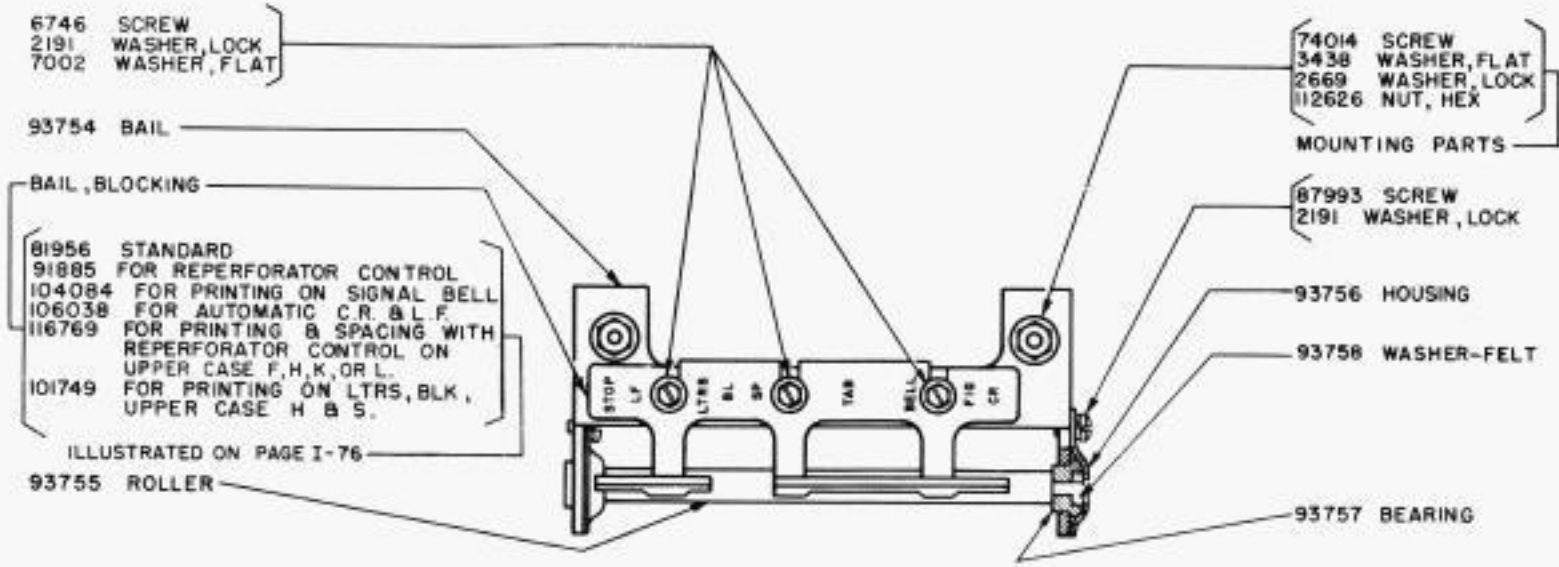

93839 FUNCTION LEVER BAIL ASSEMBLY - LESS MOUNTING PARTS
INCLUDES 81956 (STANDARD) BLOCKING BAIL

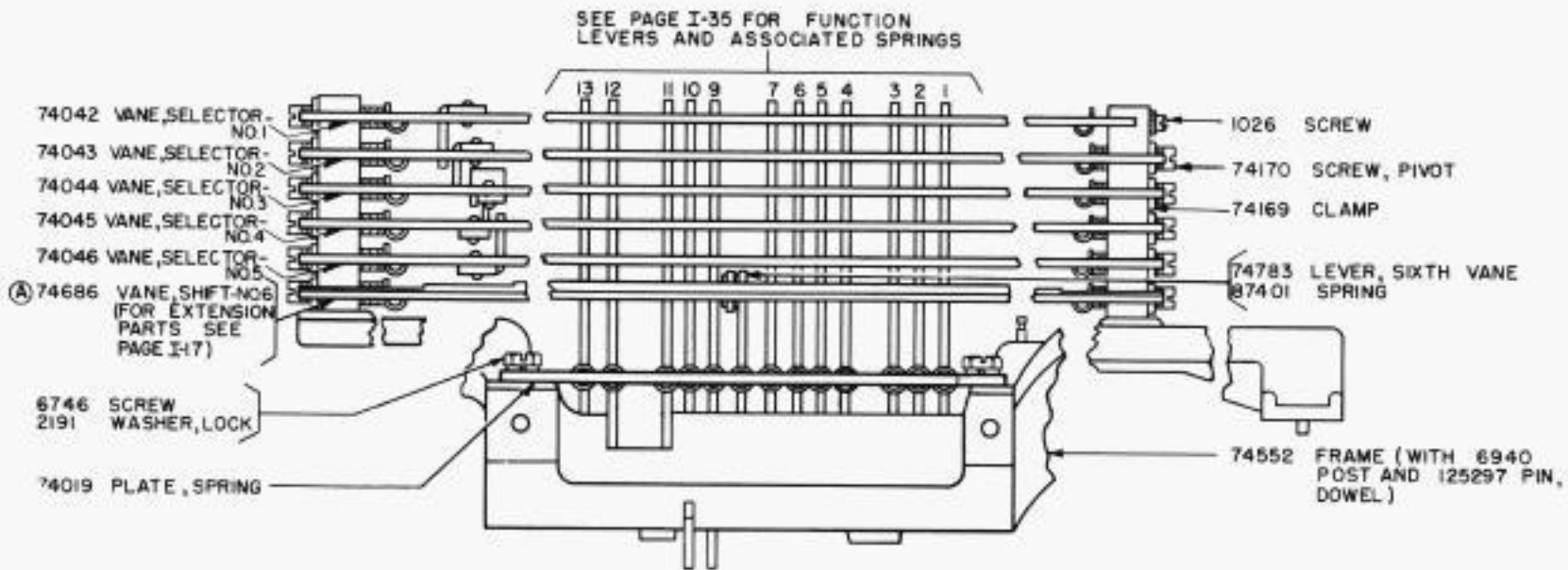

FRONT VIEW

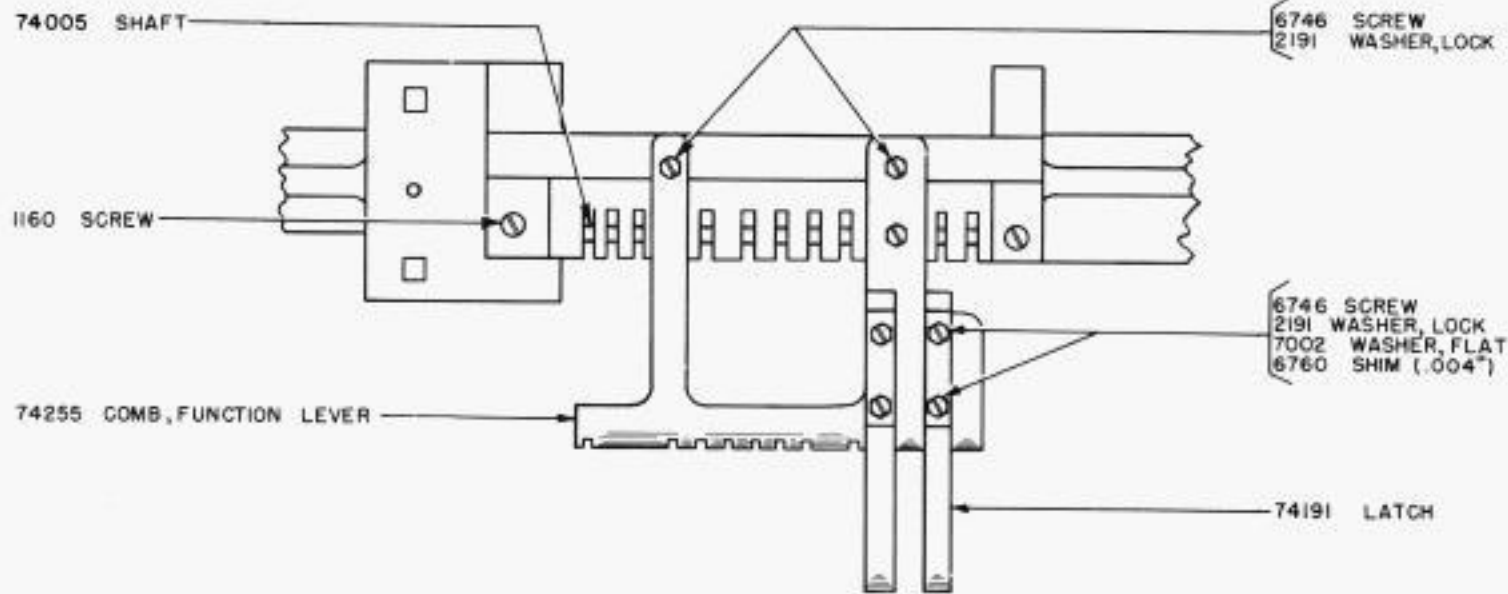

BOTTOM VIEW

VANE FRAME

(A) SEE PAGE I-17 FOR EXPLANATION

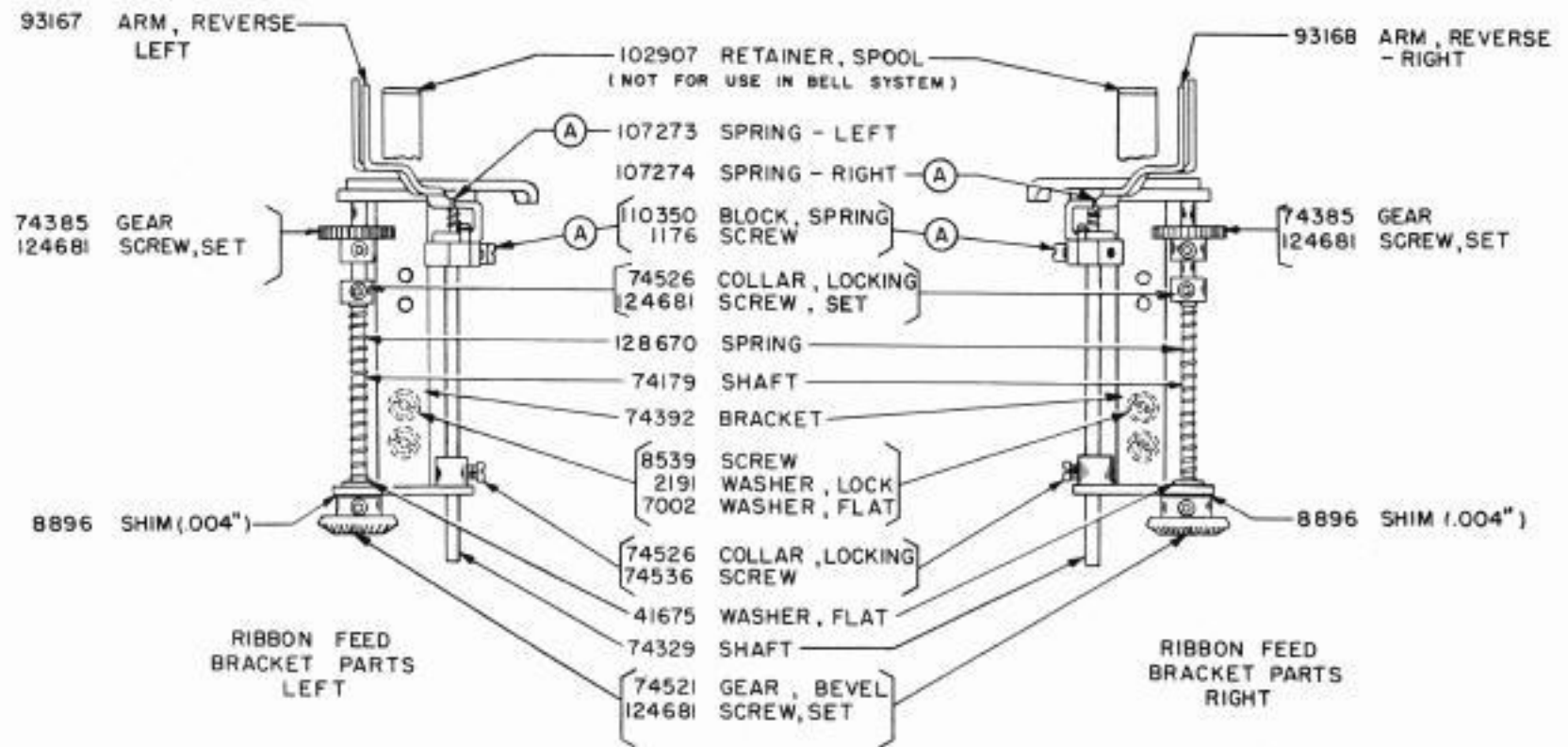
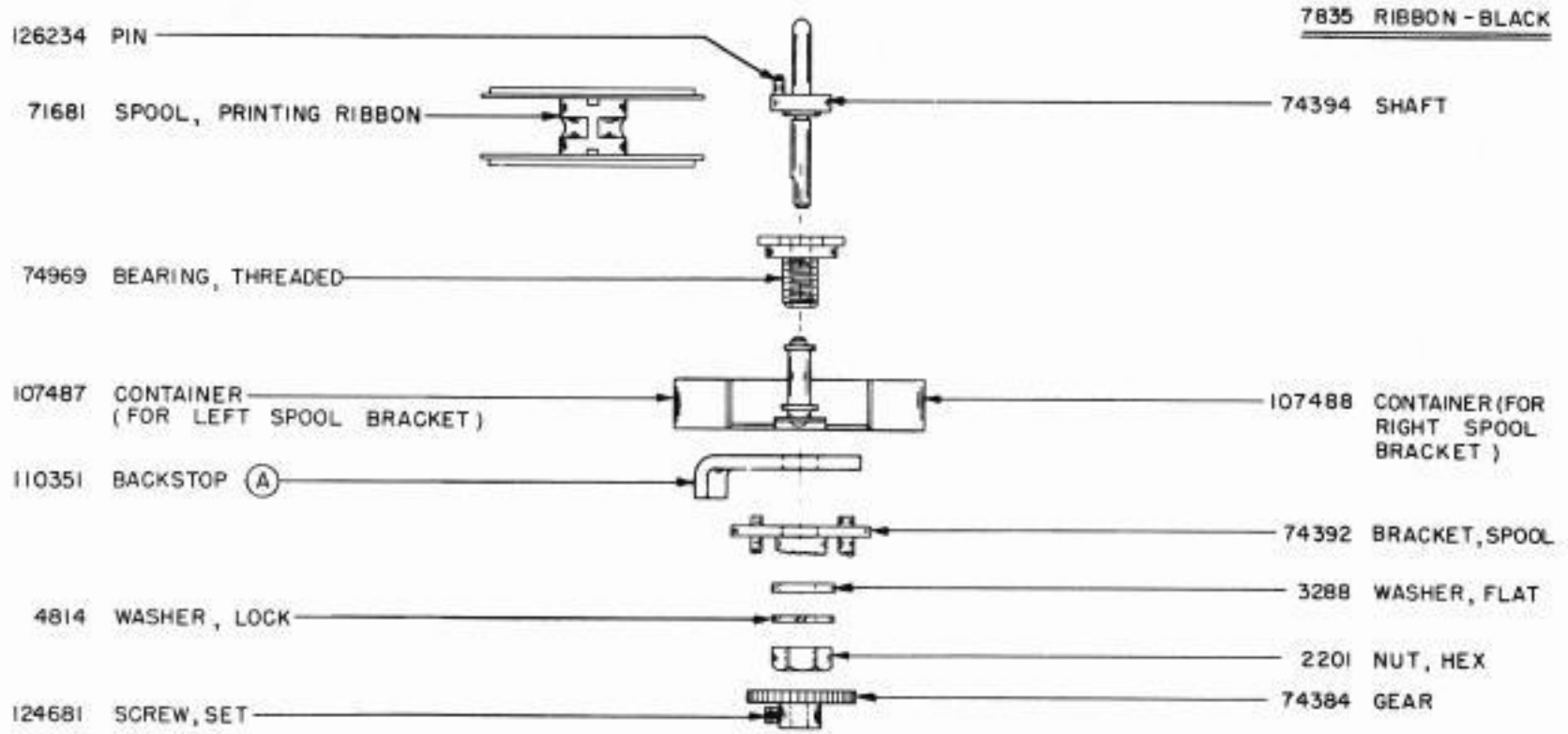

PARTS MARKED (A) COMPRISE THE 110352 SET OF RIBBON REVERSE ARM, YIELD SPRING AND BACKSTOP PARTS.

TYPE BAR CARRIAGE PARTS
(ALSO SEE PAGES I-22 & I-23)

(SEE SEC. III, PAGE I FOR OLD STYLE)

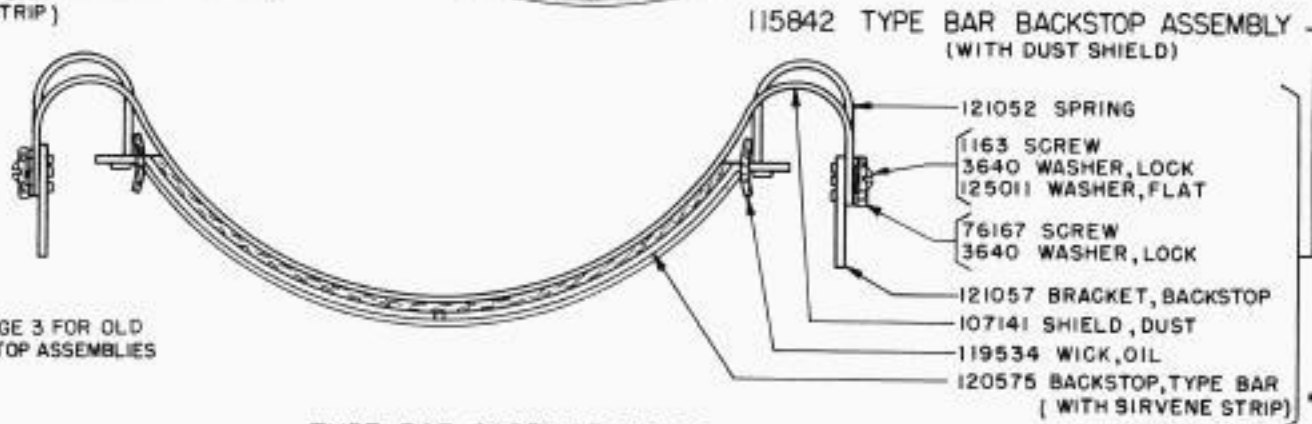
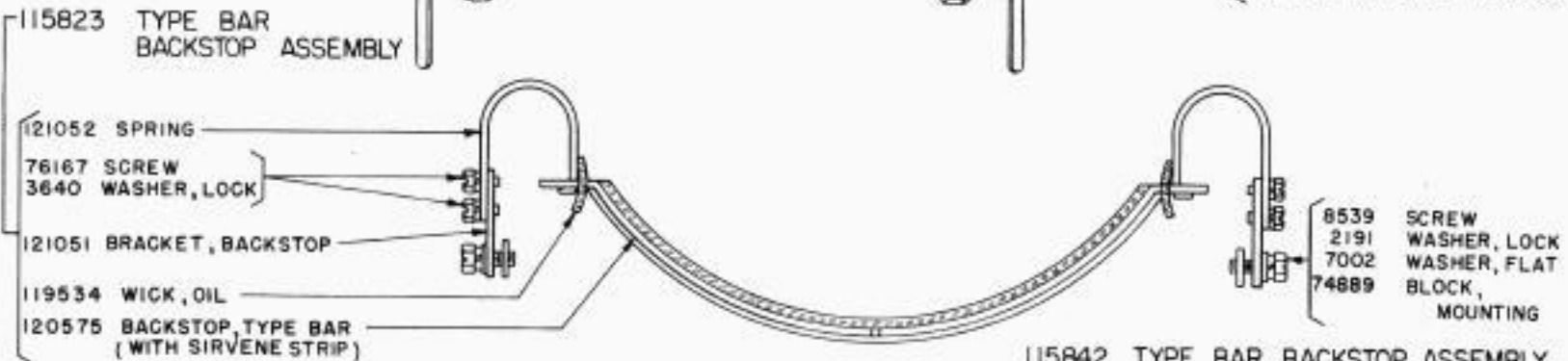
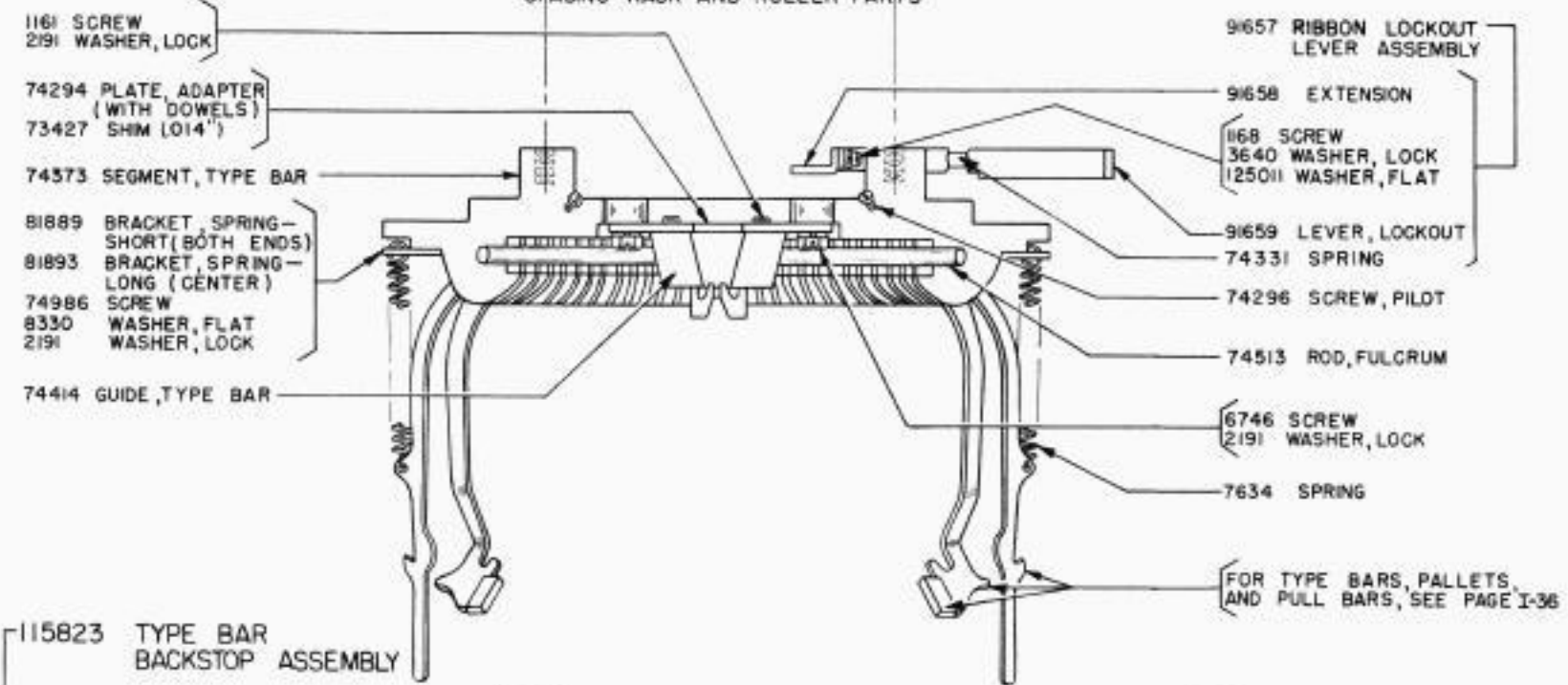
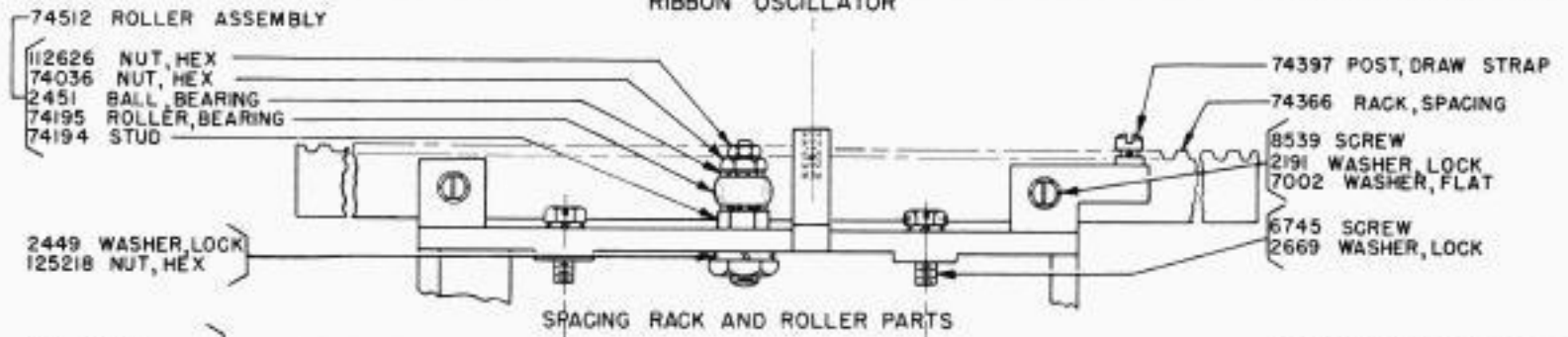
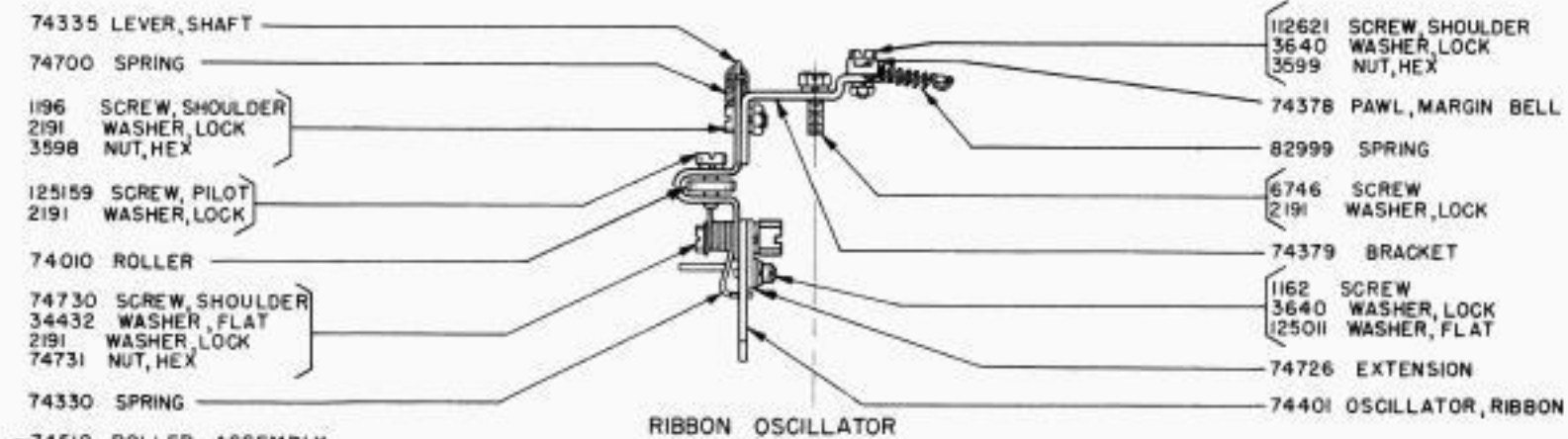

NOTE: SEE SEC III, PAGE 3 FOR OLD STYLE BACKSTOP ASSEMBLIES

TYPE BAR CARRIAGE PARTS
(ALSO SEE PAGES I-21 & I-23)

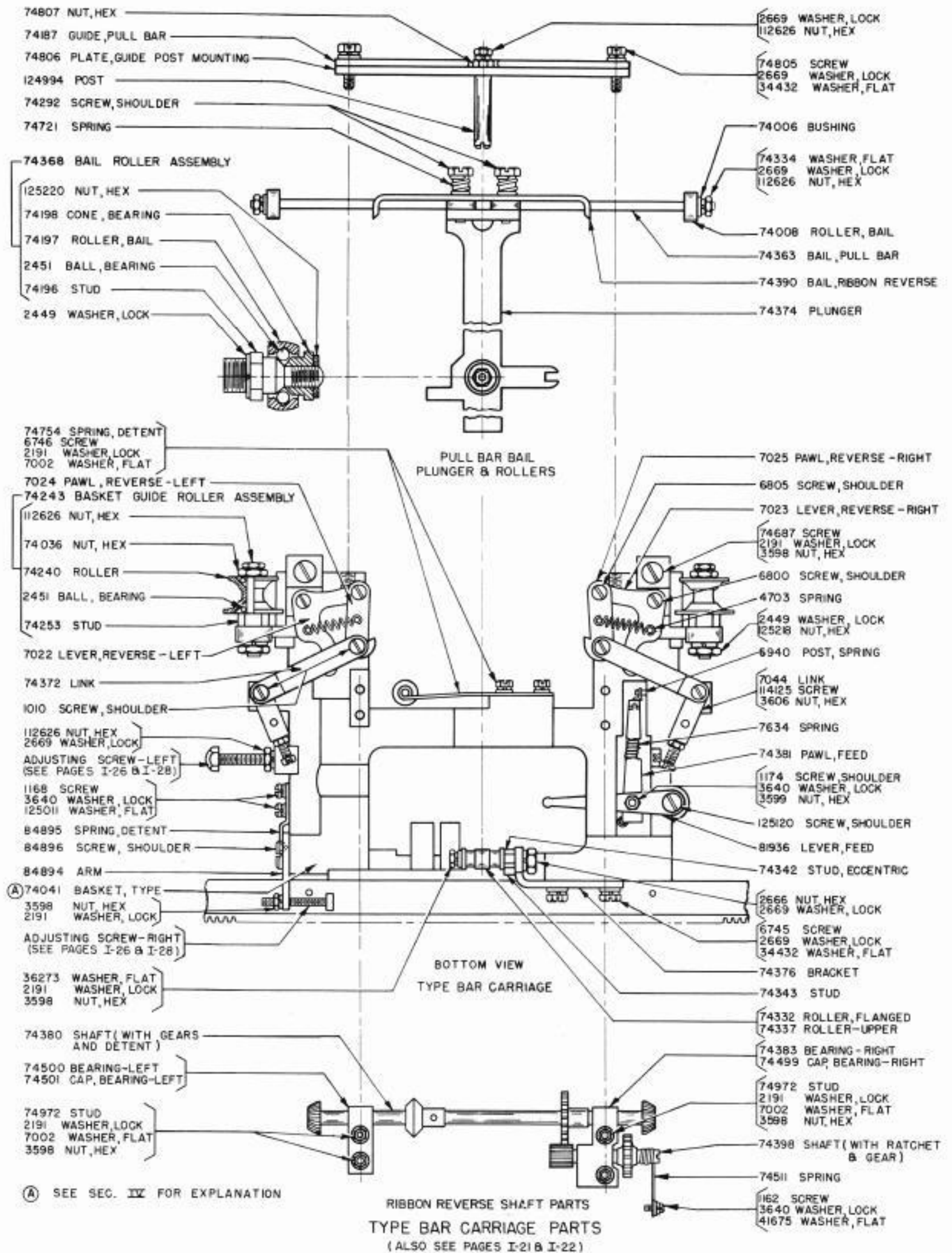

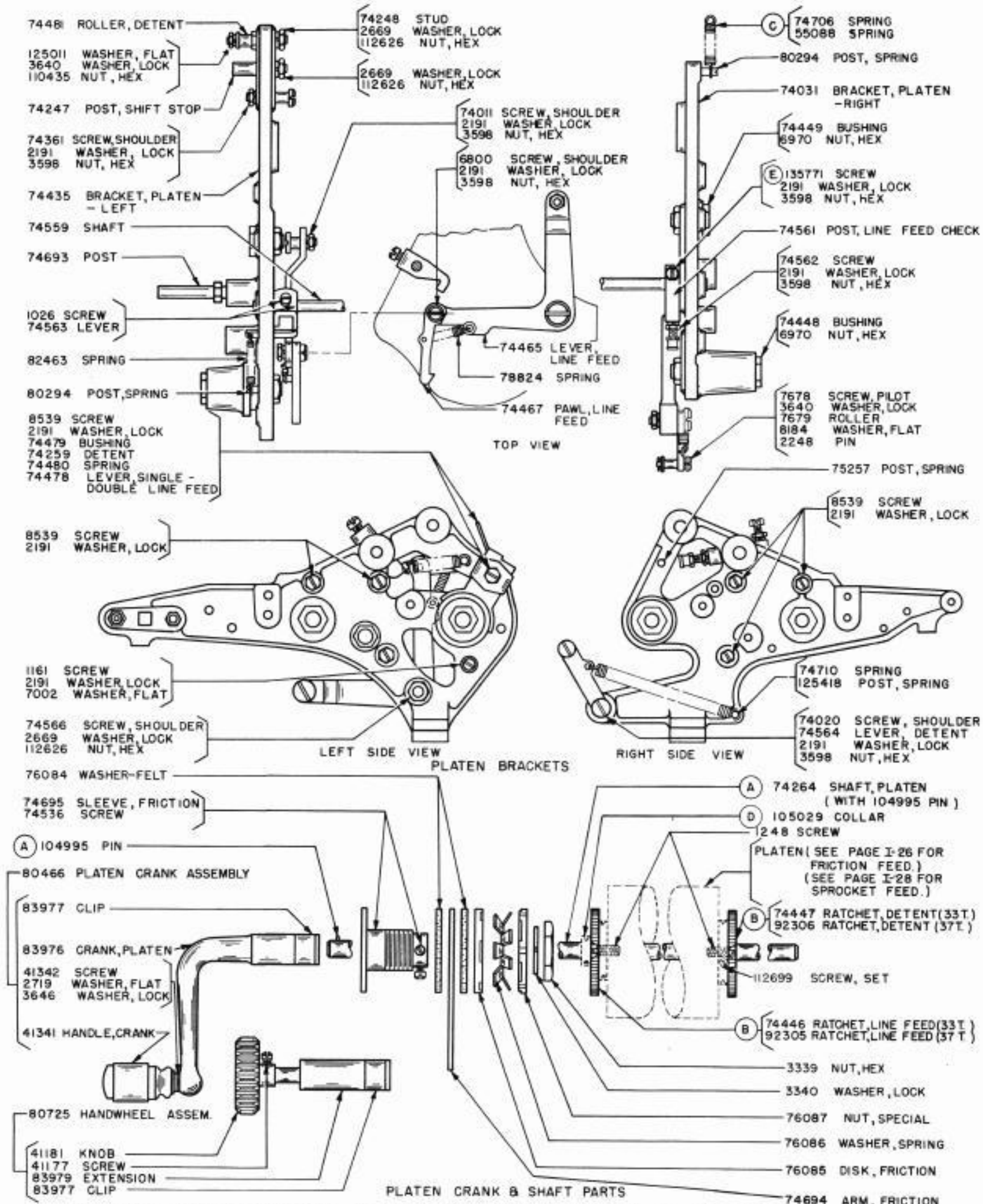

ALL PARTS ON THIS PAGE ARE FOR USE WITH EITHER FRICTION OR SPROCKET FEED PRINTERS
 (FOR PARTS USED ONLY WITH FRICTION FEED, SEE PAGES I-25 & I-26)
 (FOR PARTS USED ONLY WITH SPROCKET FEED, SEE PAGES I-27 & I-28)

(A) (B) (C) (D) (E) SEE SEC. IV FOR EXPLANATION

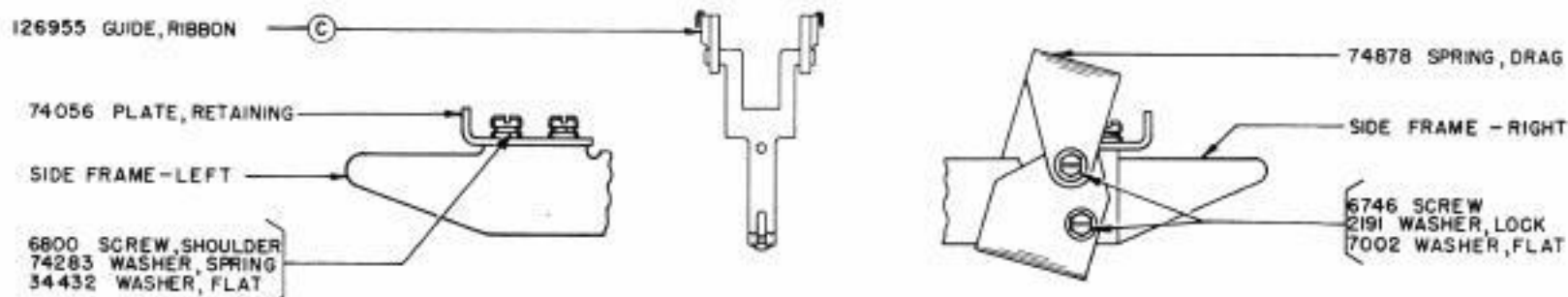
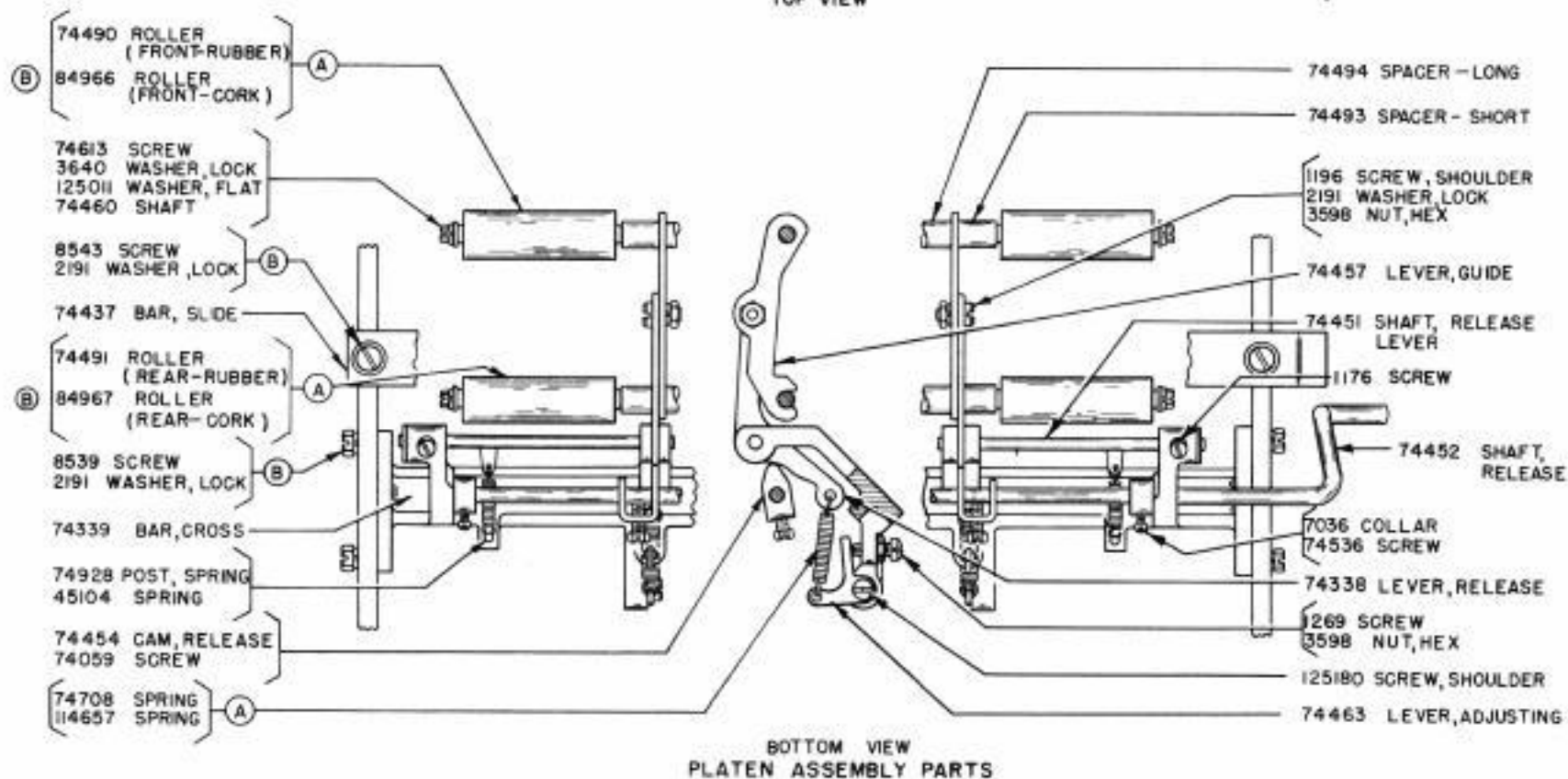
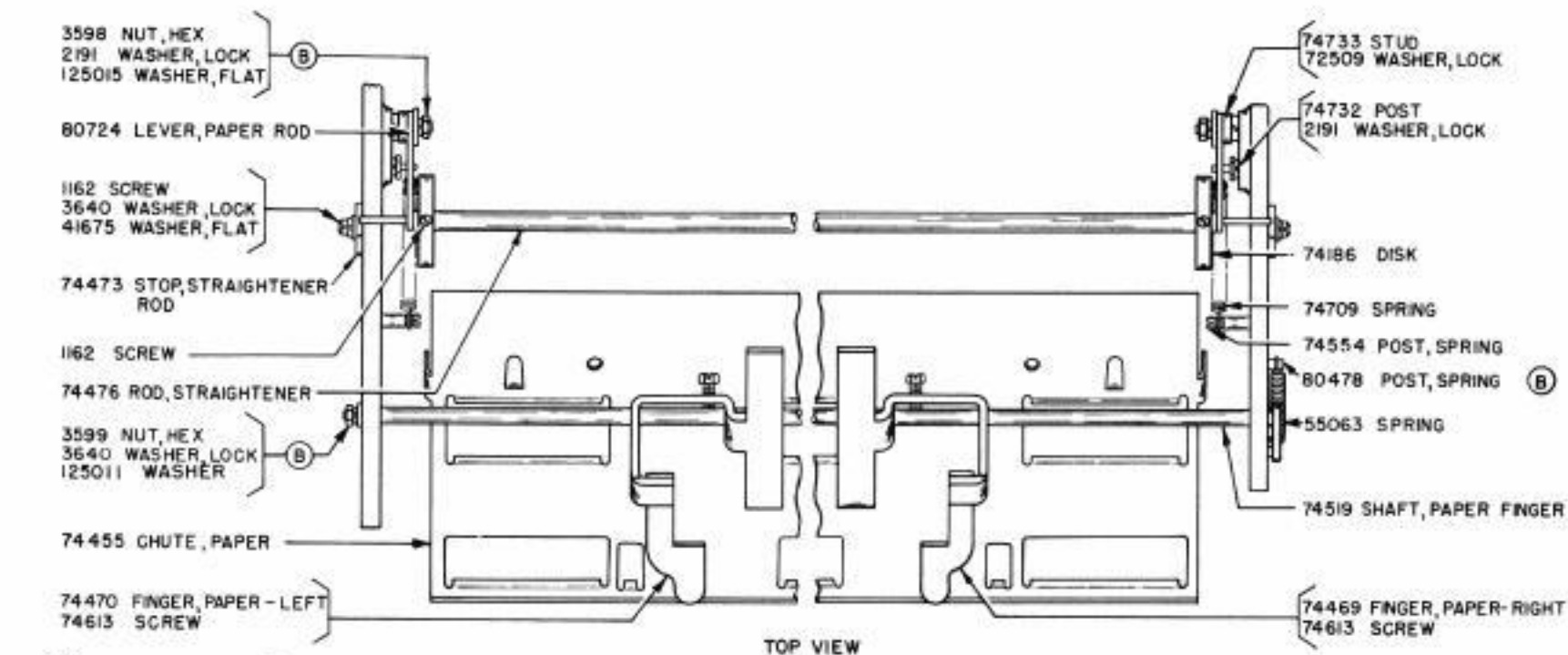

84913 SET OF PARTS FOR CONVERTING SPROCKET FEED PRINTERS TO FRICTION FEED
(EXCLUDES PARTS MARKED Ⓑ)

ALL PARTS ON THIS PAGE AND PAGE I-26 ARE FOR USE WITH FRICTION FEED PRINTERS

(FOR PARTS USED ONLY WITH SPROCKET FEED, SEE PAGES I-27 & I-28)
(FOR PARTS USED WITH EITHER FRICTION OR SPROCKET FEED, SEE PAGE I-24)

Ⓐ Ⓑ Ⓒ SEE SEC. IV FOR EXPLANATION



FRICTION FEED PLATENS				
WIDTH OF PAPER	PAPER LOCATED AT RIGHT HAND SIDE OF PLATEN			
	LEFT HAND MARGIN ADJ. SCREW	RIGHT HAND MARGIN ADJ. SCREW	PAPER ROLL SPINDLE	PLATEN RC-RUBBER COVERED HR-HARD RUBBER SJ-STEEL JACKETED
8 1/2	74367	74739	117313	74438 - RC 74820 - HR 82253 - SJ
8	80459	74739	117313	74438 - RC 74820 - HR 82253 - SJ
7	80459	74739	117313	74438 - RC 74820 - HR 82253 - SJ
6 1/2	86667	74739	117313	74438 - RC 74820 - HR 82253 - SJ
6	74923	74739	117313	74438 - RC 74820 - HR 82253 - SJ
5 1/2	74923	74739	117313	74438 - RC 74820 - HR 82253 - SJ
5	74923	74739	117313	74438 - RC 74820 - HR 82253 - SJ
4 5/16	81026	74739	117313	74438 - RC 74820 - HR 82253 - SJ

FRICTION FEED PLATENS				
WIDTH OF PAPER	PAPER CENTRALLY LOCATED			
	LEFT HAND MARGIN ADJ. SCREW	RIGHT HAND MARGIN ADJ. SCREW	PAPER ROLL SPINDLE	PLATEN RC-RUBBER COVERED HR-HARD RUBBER SJ-STEEL JACKETED
8 1/2	74367	74739	117313	74438 - RC 74820 - HR 82253 - SJ
6 1/2	80459	80458	117313	74438 - RC 74820 - HR 82253 - SJ
5 1/2	88777	88745	117313	74438 - RC 74820 - HR 82253 - SJ
5	88777	88745	117313	74438 - RC 74820 - HR 82253 - SJ

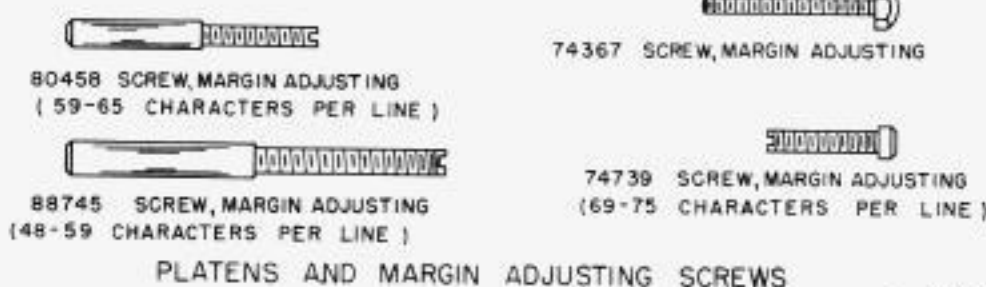
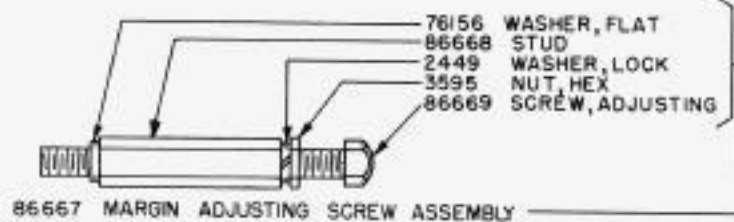
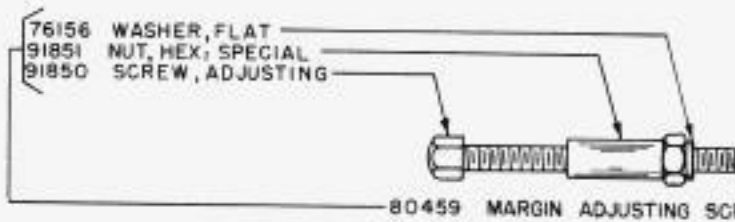
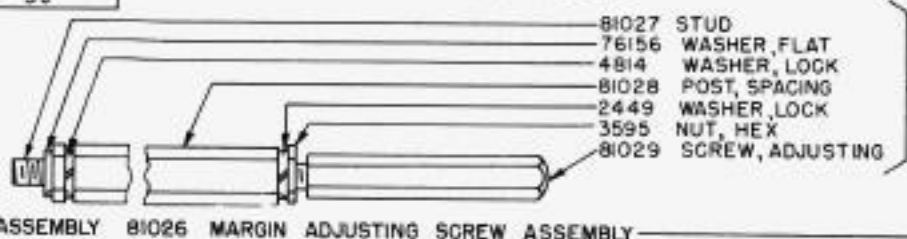
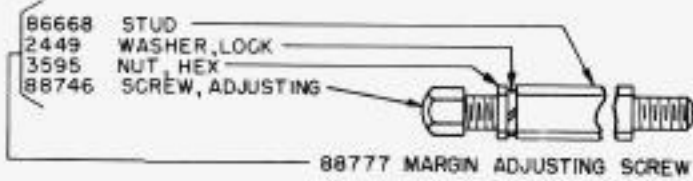
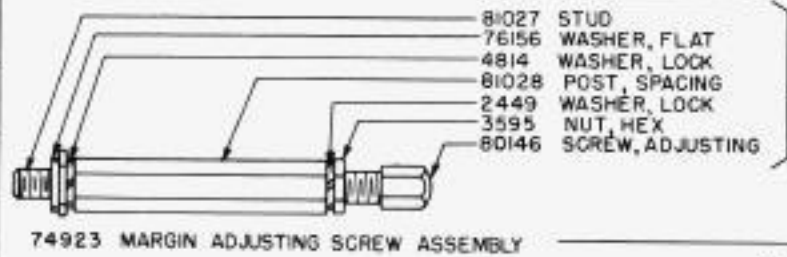

PLATENS AND MARGIN ADJUSTING SCREWS

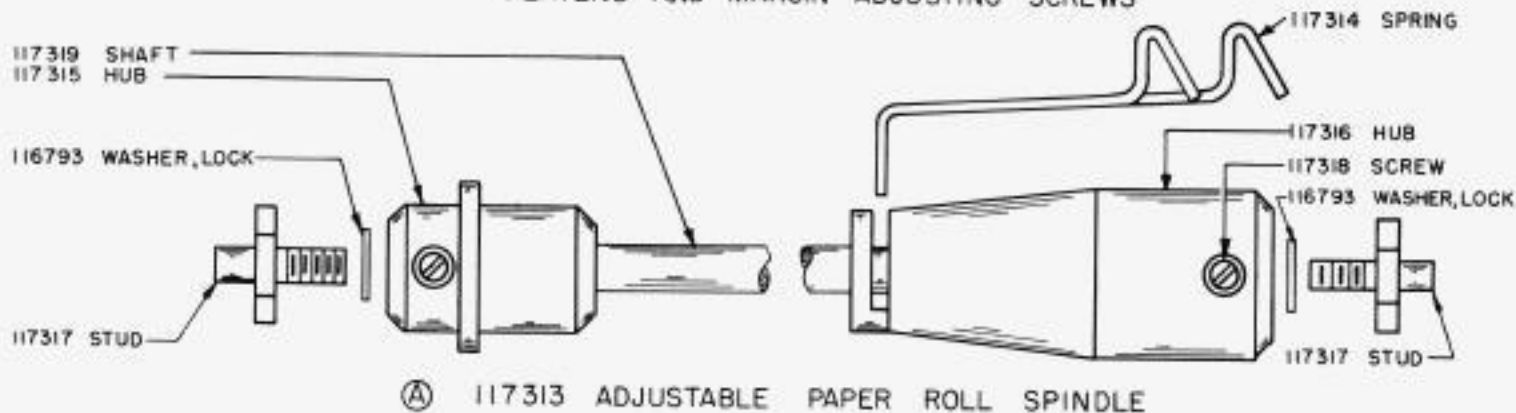

ALL PARTS ON THIS PAGE AND PAGE I-25 ARE FOR USE WITH FRICTION FEED PRINTERS
 (FOR PARTS USED WITH SPROCKET FEED, SEE PAGES I-27 & I-28)
 (FOR PARTS USED WITH EITHER FRICTION OR SPROCKET FEED, SEE PAGE I-24)

① SEE SEC. IV FOR EXPLANATION

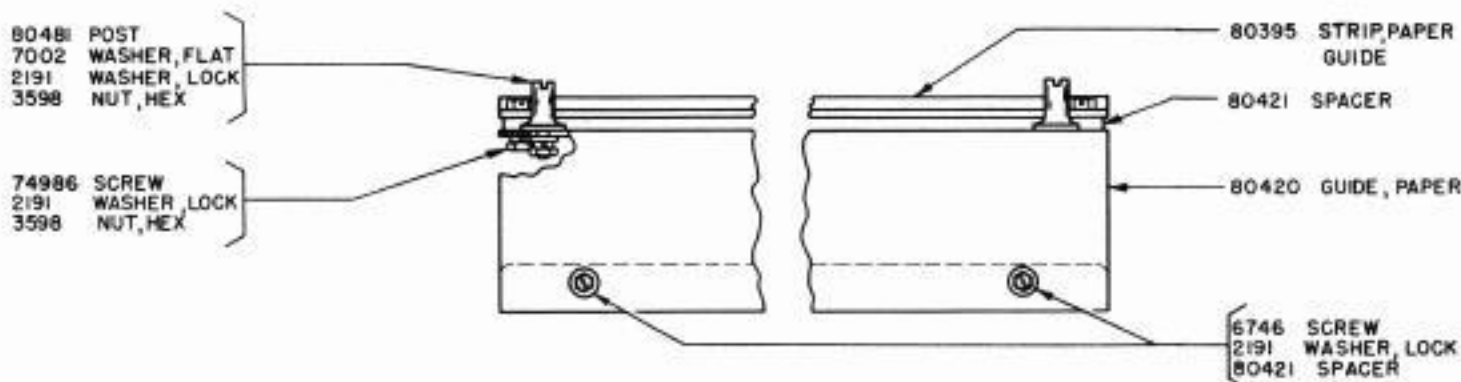

87154 SET OF PARTS TO PROVIDE A PAPER GUIDE ON THE COVER

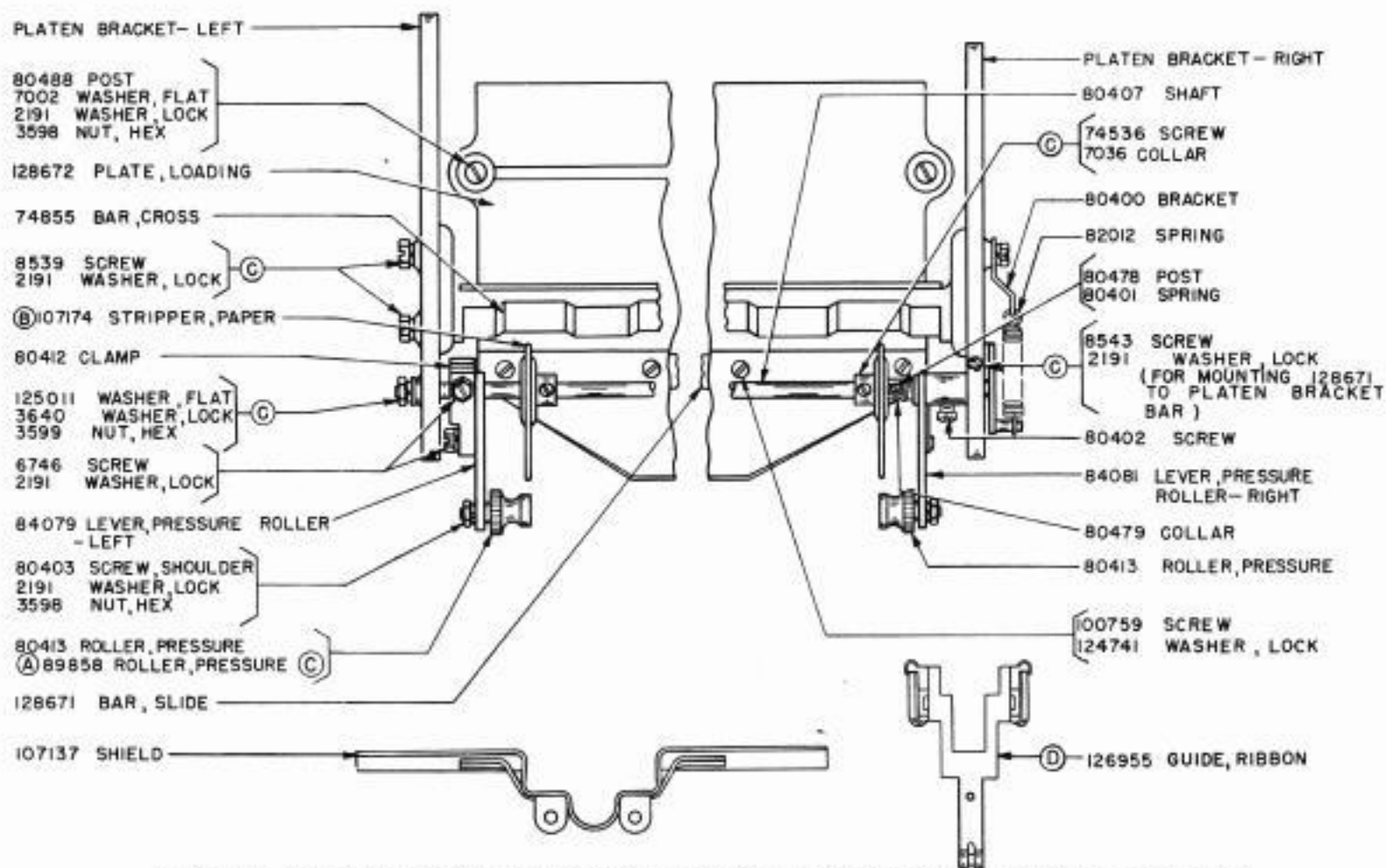
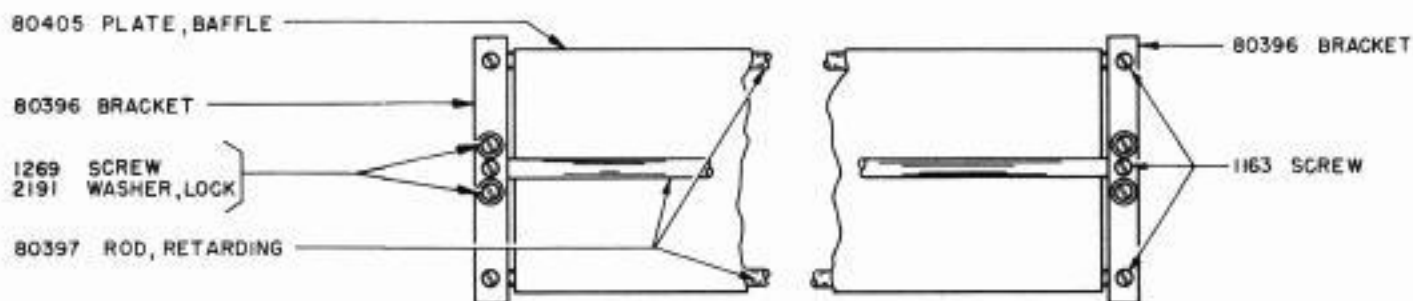

115872 SET OF PARTS TO CONVERT A FRICTION FEED TYPING UNIT INTO A SPROCKET FEED TYPING UNIT (EXCLUDES PARTS MARKED ©)

80483 SET OF PARTS FOR CONVERTING FRICTION FEED PRINTERS TO SPROCKET FEED (INCLUDES 87154 AND 115872 SET OF PARTS SHOWN ABOVE (EXCLUDES PARTS MARKED ©))

ALL PARTS ON THIS PAGE AND PAGE I-28 ARE FOR USE WITH SPROCKET FEED PRINTERS

(FOR PARTS USED ONLY WITH FRICTION FEED, SEE PAGES I-25 & I-26)
 (FOR PARTS USED WITH EITHER FRICTION OR SPROCKET FEED, SEE PAGE I-24)

(A), (B) & (D) SEE SEC. IV FOR EXPLANATION

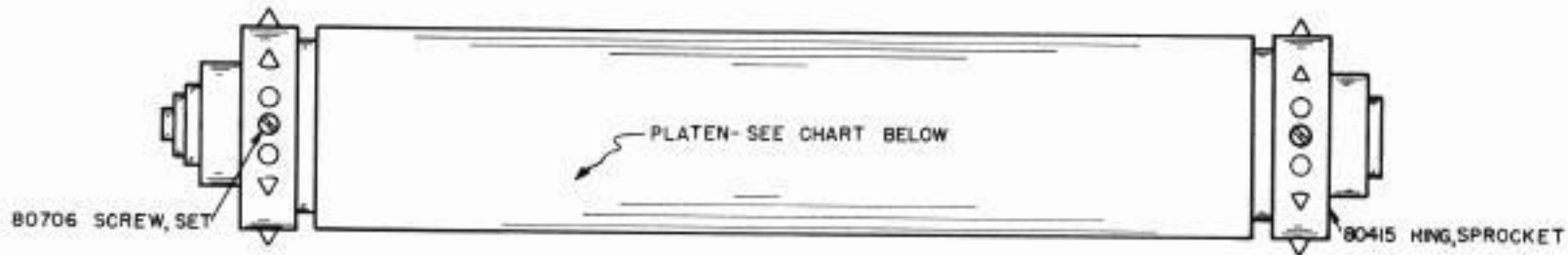

SPROCKET FEED PLATENS

* WIDTH OF PAPER	PAPER LOCATED AT RIGHT HAND SIDE OF PLATEN			
	LEFT HAND MARGIN ADJ. SCREW	RIGHT HAND MARGIN ADJ. SCREW	PLATEN HR - HARD RUBBER RC - RUBBER COVERED SJ - STEEL JACKETED	PLATEN WITH RINGS, SET SCREWS, AND LEFT HAND MARGIN ADJ. SCREW (SEE NOTES 1 AND 2)
8 1/2"	74367	74739	80422 (RC) 80765 (SJ) 135000 (HR)	80722 (RC) 80766 (SJ) 135001 (HR)
8"	80459	74739	80217 (RC) 89971 (SJ)	80723 (RC) 89972 (SJ)
7 1/2"	80459	74739	118265 (RC)	118267 (RC)
7"	80459	74739	82174 (RC)	82175 (RC)
6 1/2"	86667	74739	84902 (RC) 91509 (SJ)	89540 (RC) 91512 (SJ)
6 3/8"	86667	74739	92796 (RC)	92798 (RC)
6 1/4"	86667	74739	92819 (SJ)	** 92821 (SJ)
6 1/4"	86667	74739	99458 (RC)	99440 (RC)
6 1/4"	74923	74739	102369 (SJ)	102372 (SJ)
6"	74923	74739	80216 (RC) 81802 (SJ)	80598 (RC) 81801 (SJ)
5 3/4"	74923	74739	82172 (RC) 92795 (SJ)	82173 (RC) 92793 (SJ)
5 1/2"	74923	74739	80248 (RC) 81806 (SJ)	80599 (RC) 81805 (SJ)
5"	74923	74739	80451 (RC)	80600 (RC)
4 1/2"	81026	74739	92304 (RC) 92300 (SJ)	92308 (RC) 92303 (SJ)
4 5/16"	81026	74739	80249 (RC)	80601 (RC)
4 1/4"	81026	74739	91136 (RC)	91135 (RC)
4"	81026	74739	81025 (RC) 91868 (SJ)	81024 (RC) 91871 (SJ)
3 5/8"	81026	74739	88832 (RC)	88833 (RC)

NOTE 1

NO MARGIN ADJUSTING SCREW WITH 8-1/2" PLATENS

NOTE 2

WHEN CONVERTING FROM FRICTION FEED (NARROW PAPER, CENTRALLY LOCATED) TO SPROCKET FEED, THE RIGHT HAND MARGIN SCREW MUST ALSO BE CHANGED.

* THE WIDTH SHOWN IS THE OVERALL DIMENSION OF THE PAPER AND THE DISTANCE BETWEEN SPROCKET PIN HOLES IS 1/2" LESS.

** THE 92821 PLATEN ASSEMBLY HAS SPROCKET PINS ON THE LEFT HAND RING ONLY.

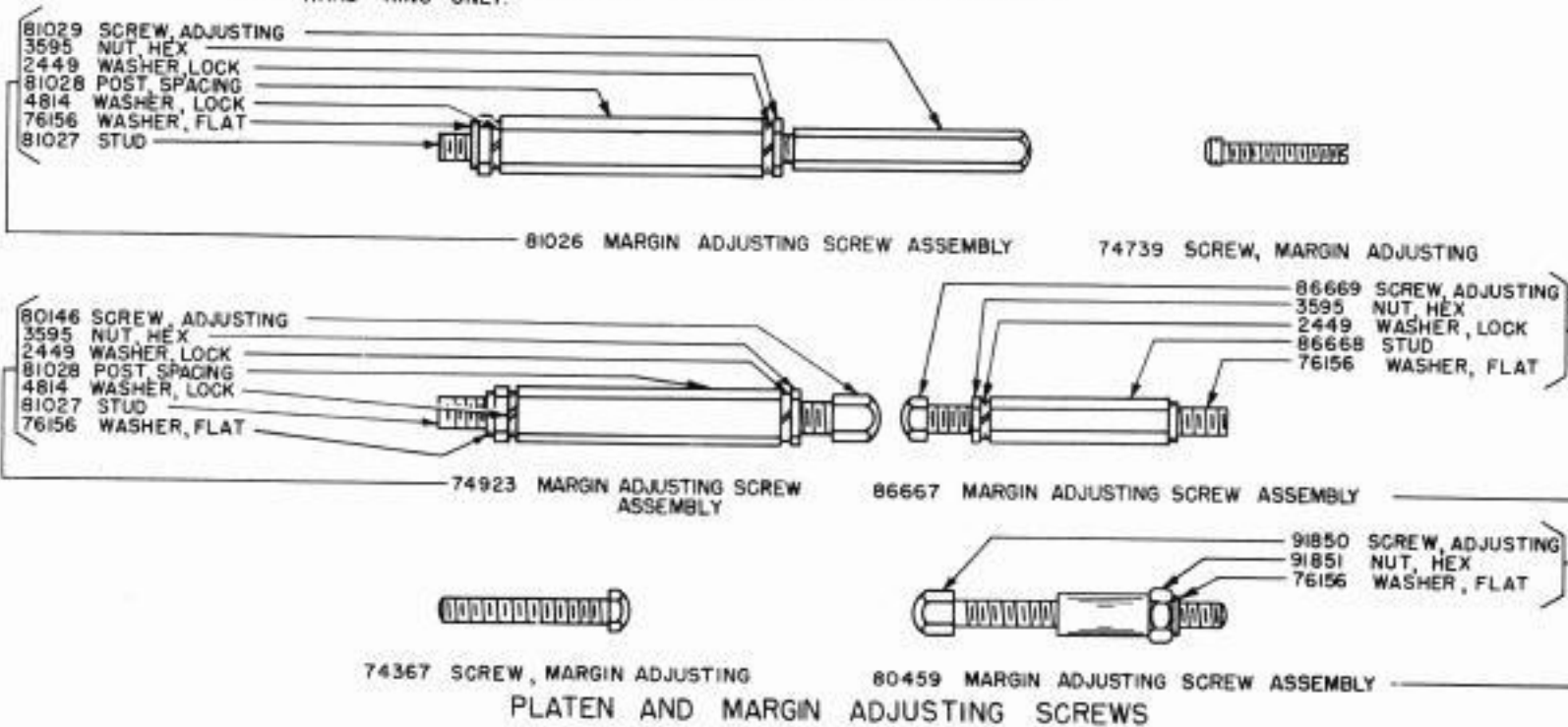

PLATEN AND MARGIN ADJUSTING SCREWS

ALL PARTS ON THIS PAGE AND PAGE I-27 ARE FOR USE WITH SPROCKET FEED PRINTERS

(FOR PARTS USED ONLY WITH FRICTION FEED, SEE PAGES I-25 & I-26)
(FOR PARTS USED WITH EITHER FRICTION OR SPROCKET FEED, SEE PAGE I-24)

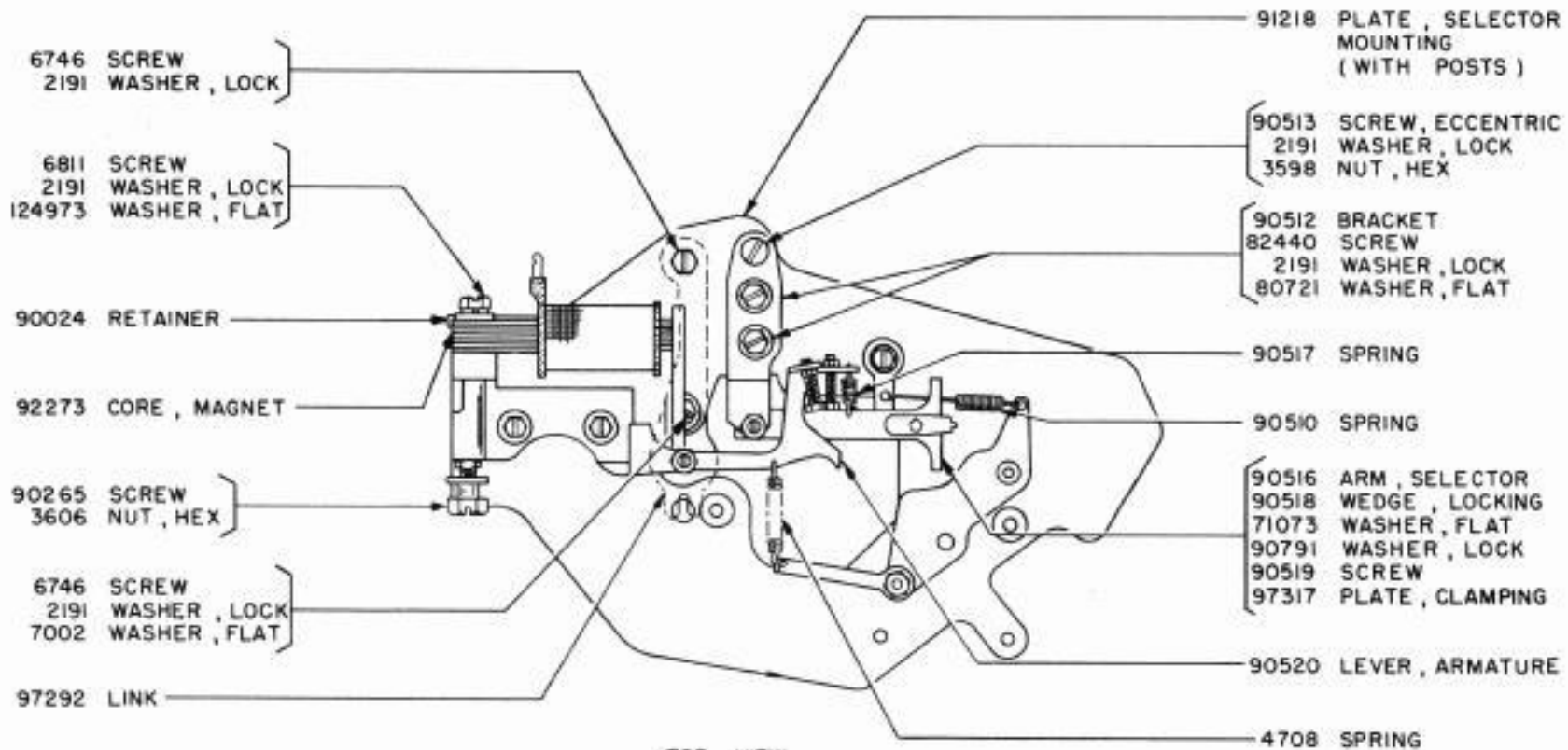

TOP VIEW

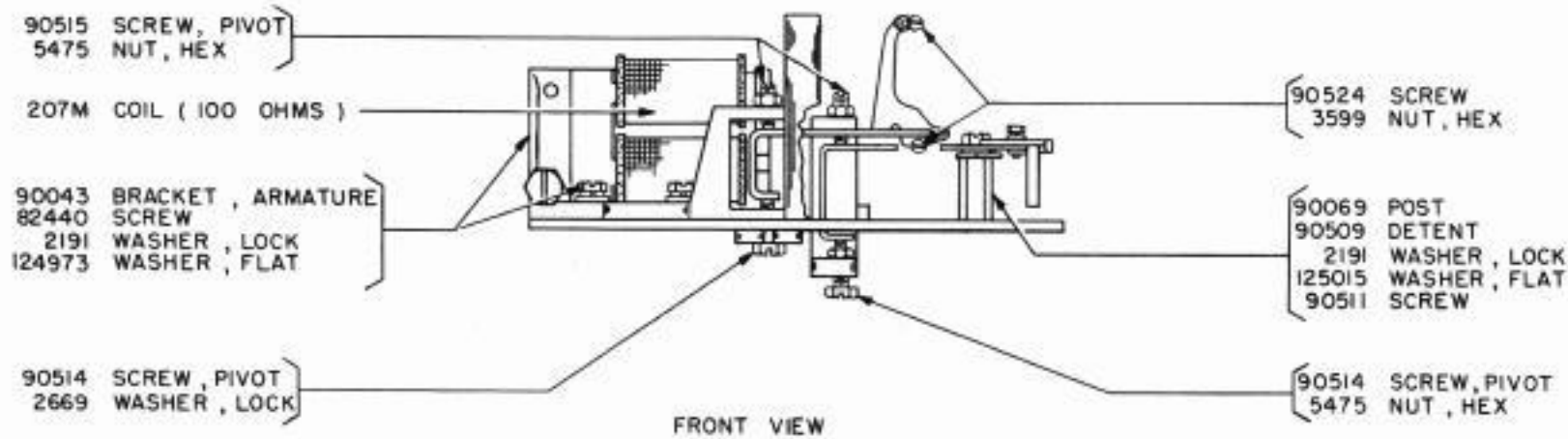

FRONT VIEW

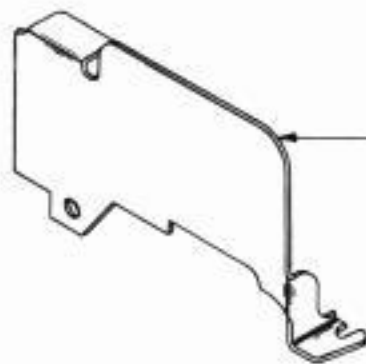

- (A) 92109 SHIELD, DUST (NOT FURNISHED WITH SELECTOR UNITS BUT MAY BE ORDERED FOR SPECIAL APPLICATIONS.)

HOLDING MAGNET SELECTOR

ALL PARTS ON THIS PAGE AND PAGES I-30 & I-31 ARE FOR USE WITH HOLDING MAGNET SELECTORS (FOR PARTS USED WITH PULLING MAGNET SELECTORS, SEE PAGES I-32 & I-33)

NOTE: 95380 SET OF PARTS CONVERTING A TYPING UNIT WITH A PULLING MAGNET SELECTOR TO A TYPING UNIT WITH A HOLDING MAGNET SELECTOR CONSISTS OF PARTS ON THIS PAGE AND PAGES I-30 & I-31 (EXCLUDING PARTS MARKED (A))

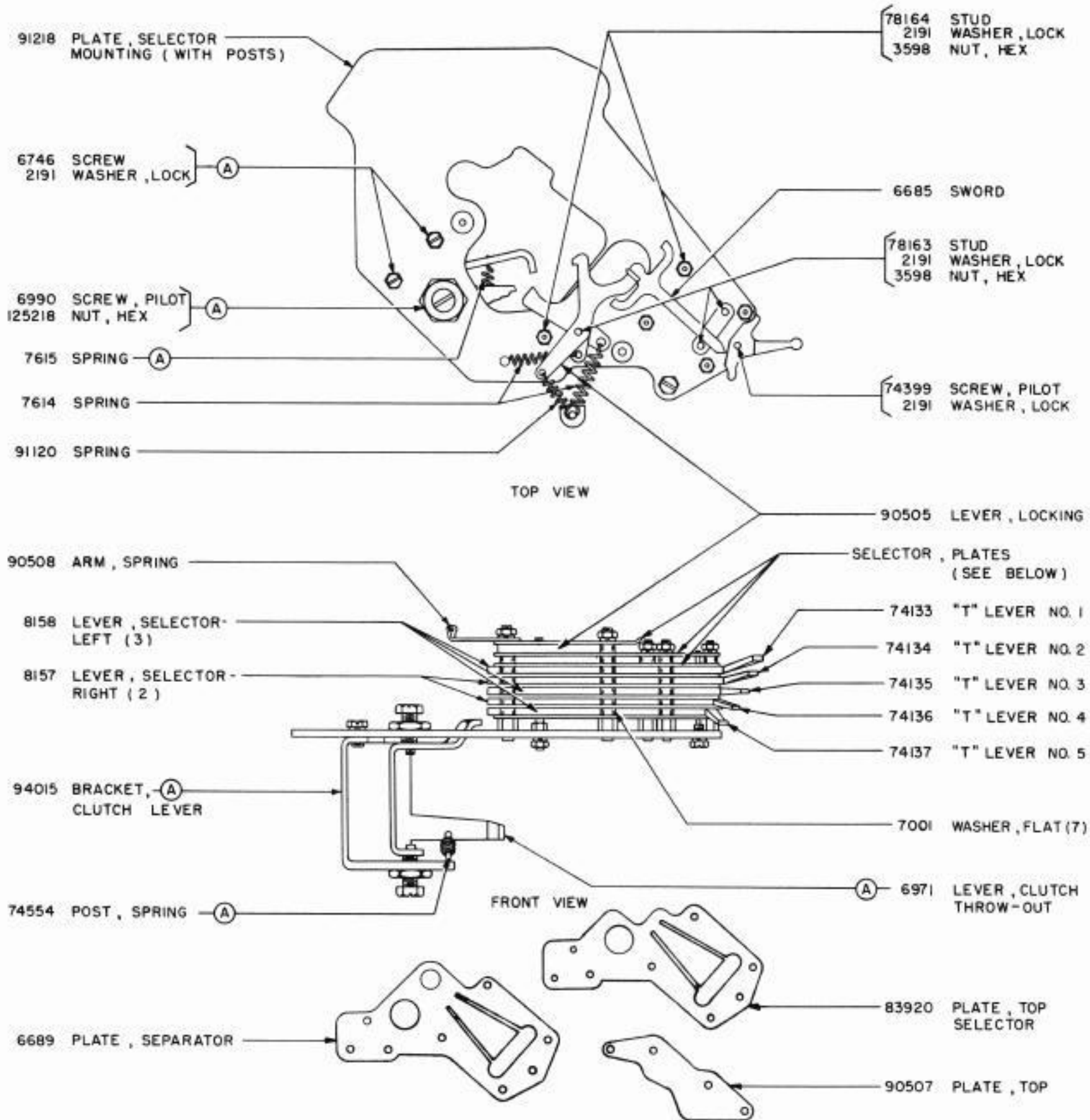

HOLDING MAGNET SELECTOR

ALL PARTS ON THIS PAGE AND PAGES I-298 I-31 ARE FOR USE WITH HOLDING MAGNET SELECTORS

(FOR PARTS USED WITH PULLING MAGNET SELECTORS, SEE PAGES I-32 & I-33)

(A) SEE NOTE ON PAGE I-29

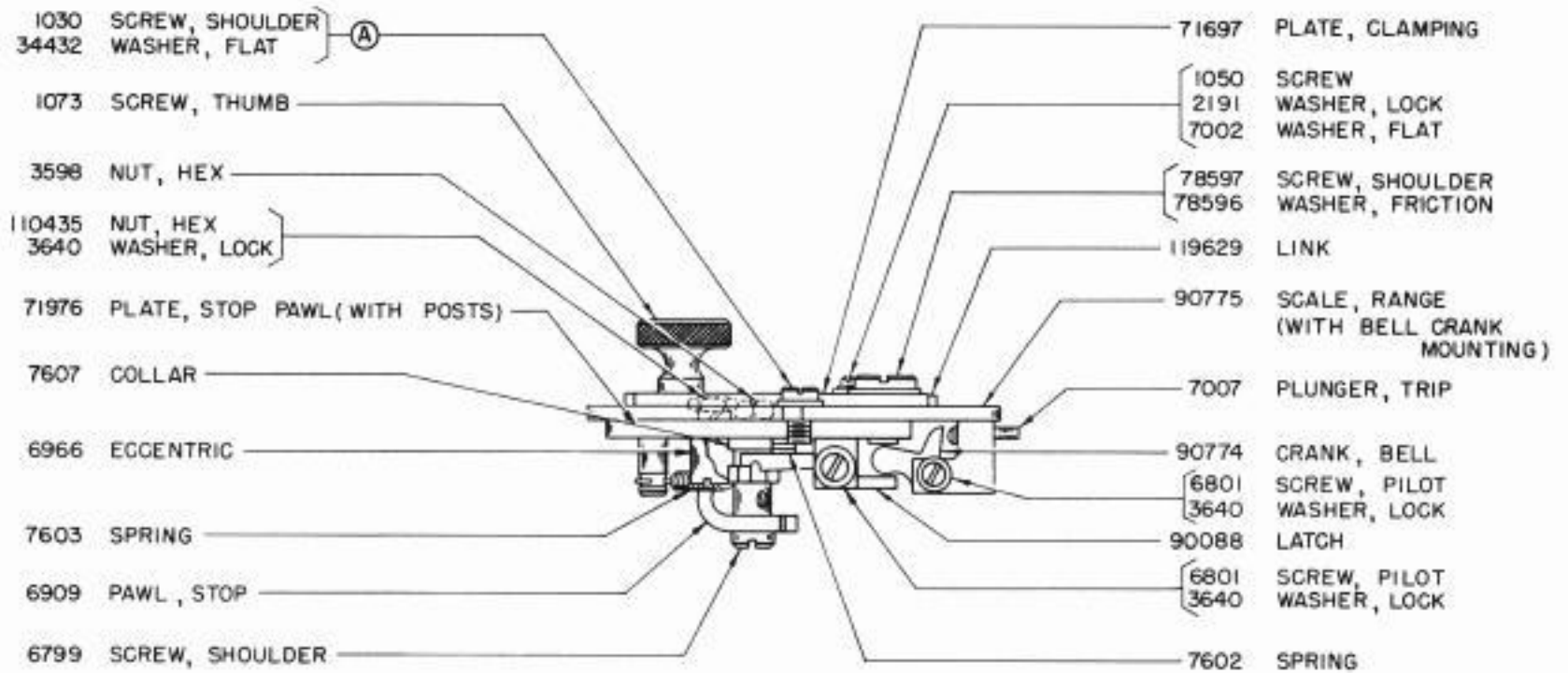

90760 RANGE SCALE ASSEMBLY
(EXCLUDES PARTS MARKED (A))



MAIN SHAFT PARTS
(FOR OTHER MAIN SHAFT PARTS SEE PAGE I-16)

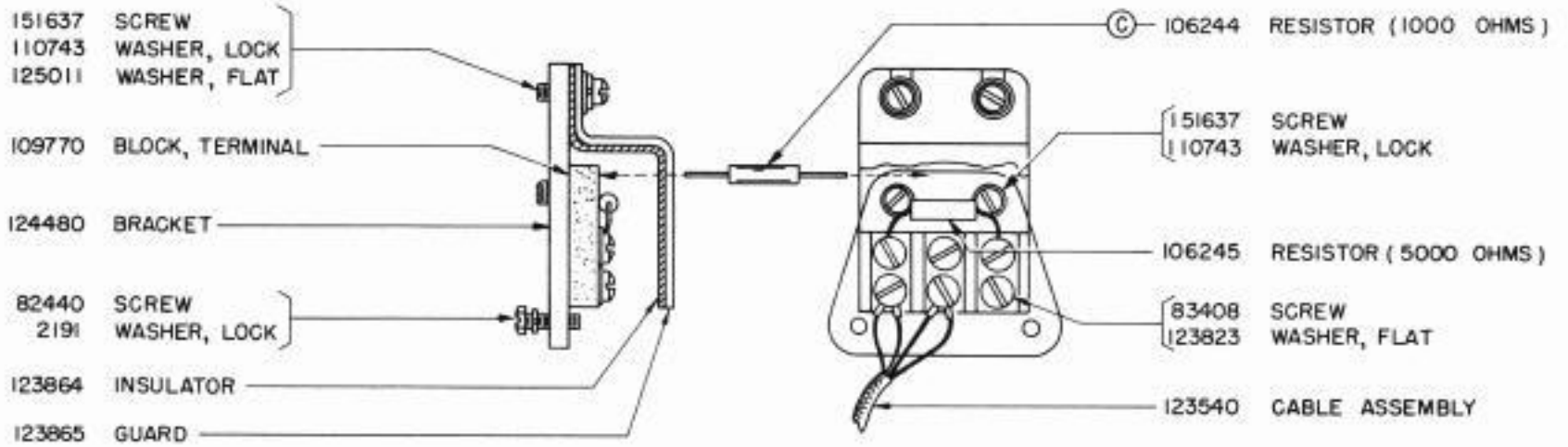

(B) 113703 TERMINAL BLOCK ASSEMBLY (SERIES - PARALLEL)
(EXCLUDES PARTS MARKED (C))

(A) & (B) 113704 TERMINAL BLOCK ASSEMBLY (SERIES - PARALLEL)
(INCLUDES PARTS MARKED (C)) NOT FOR USE IN BELL SYSTEM
SUPERSEDES 94490 SWITCH ASSEMBLY (SERIES - PARALLEL) SEE SEC. III, PAGE 3

ALL PARTS ON THIS PAGE AND PAGES I-29 & I-30 ARE FOR USE WITH HOLDING MAGNET SELECTORS
(FOR PARTS USED WITH PULLING MAGNET SELECTORS, SEE PAGES I-32 & I-33)

- (A) SEE NOTE ON PAGE I-29
- (B) SEE SEC. IV FOR EXPLANATION

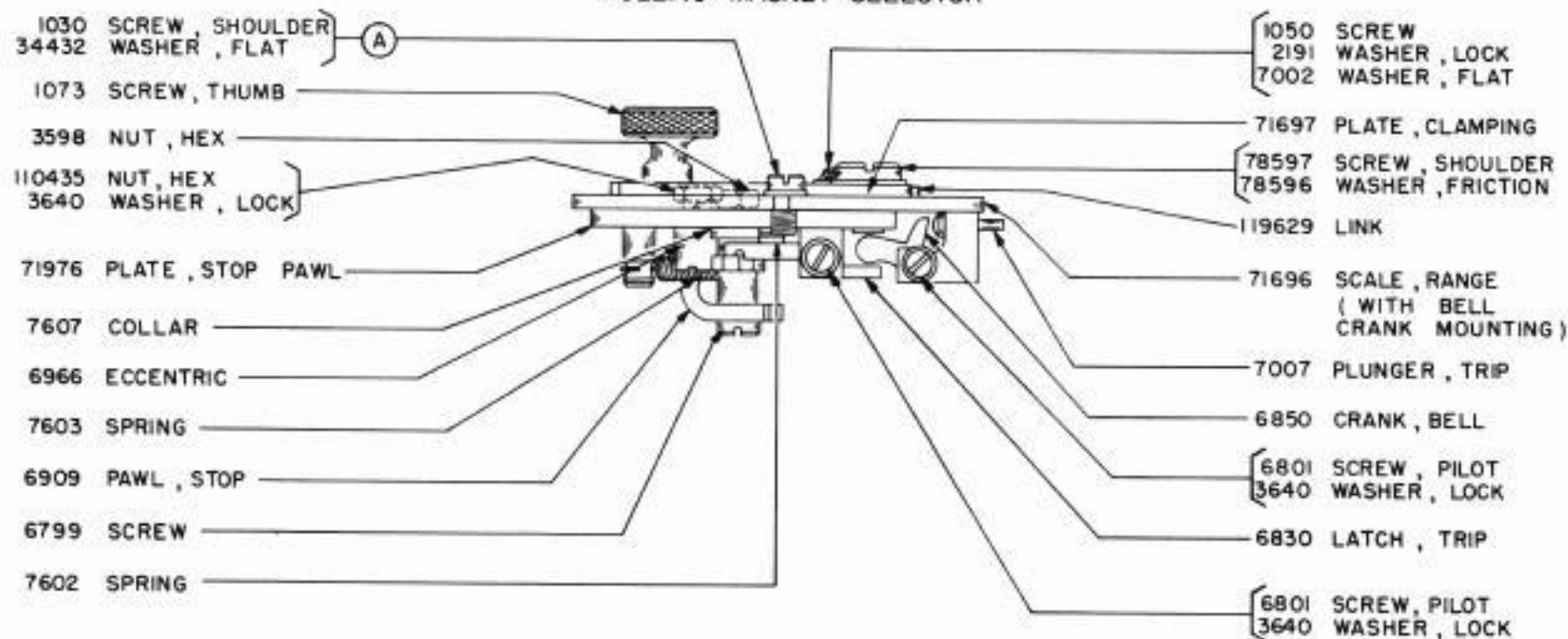
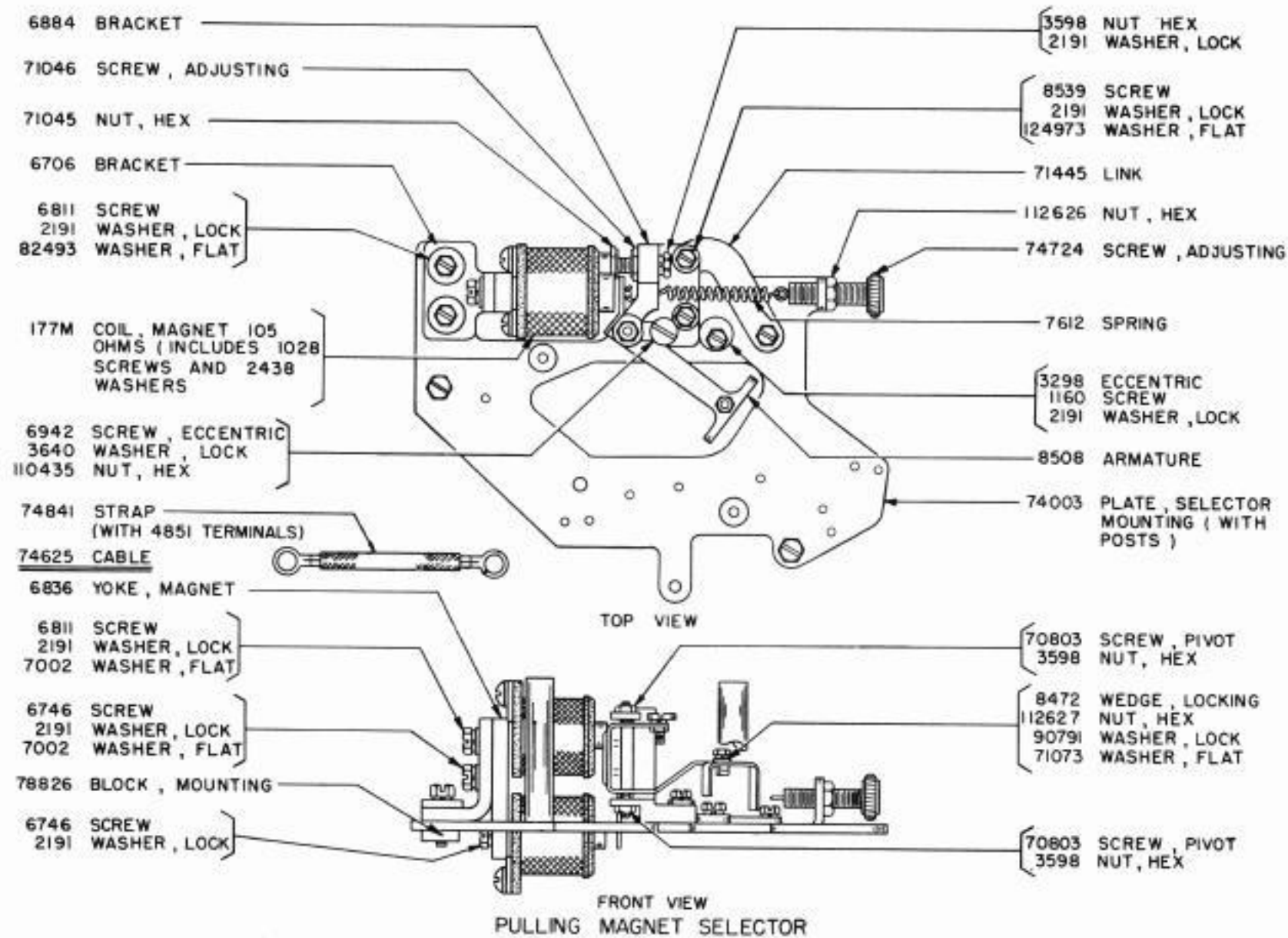

71829 RANGE SCALE ASSEMBLY
(EXCLUDES PARTS MARKED (A))

ALL PARTS ON THIS PAGE AND PAGE I-33 ARE FOR USE WITH
PULLING MAGNET SELECTORS
(FOR PARTS USED WITH HOLDING MAGNET SELECTORS, SEE PAGES I-29, I-30 & I-31)

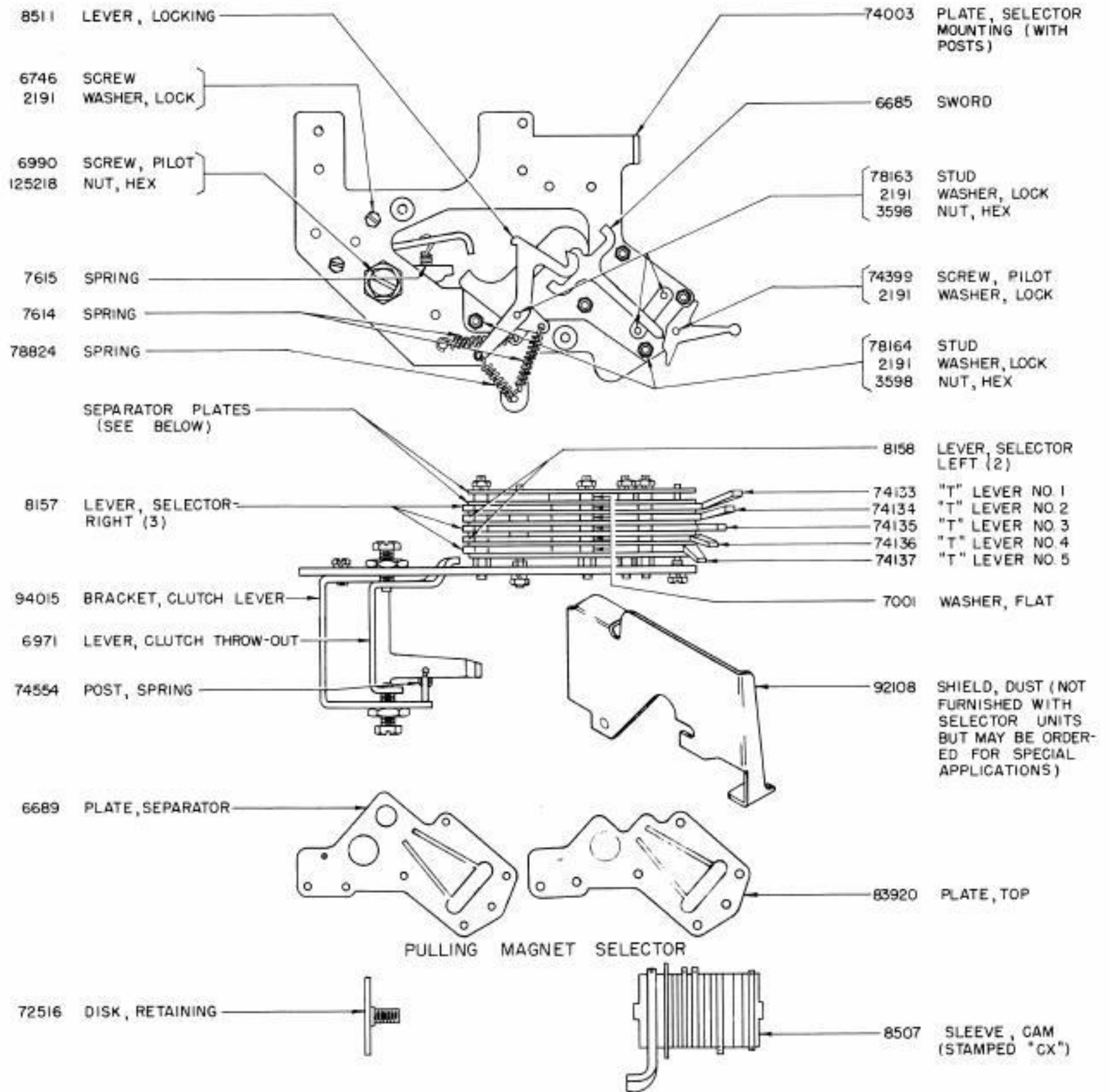

MAIN SHAFT PARTS

(FOR OTHER MAIN SHAFT PARTS SEE PAGE I-16)

ALL PARTS ON THIS PAGE AND PAGE I-32 ARE FOR USE WITH PULLING MAGNET SELECTORS
(FOR PARTS USED WITH HOLDING MAGNET SELECTORS, SEE PAGE I-29, I-30 & I-31)

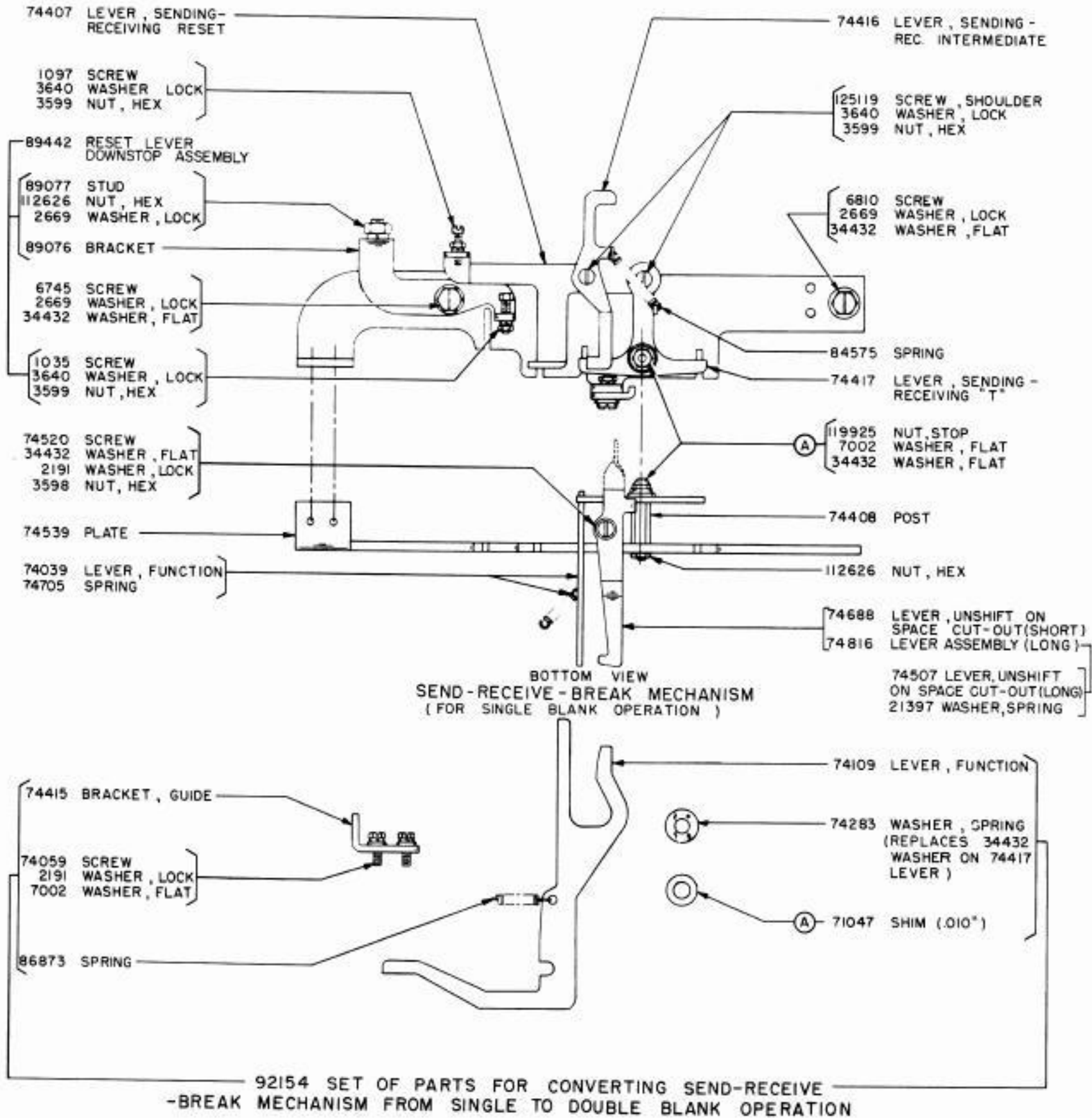

(A) SEE SEC. IV FOR EXPLANATION

FUNCTION LEVERS						
CATALOG NUMBER	POSITION USED	FUNCTION PERFORMED	SPRING	CODE SELECTION	OLD STAMPING	NEW STAMPING
74040	1	LOCKS VANES	74962	ALL COMBINATIONS	1	1
74131	2	CARRIAGE RETURN	74961	---4-	2	POS. 2 OR 3 74131
(A) 84927	2	CARRIAGE RETURN IN "LETTERS" POSITION ONLY	74961	---4-	2-B	POS. S2 84927
106145	2	CARRIAGE RETURN FOR AUTOMATIC C.R. & L.F.	74705	---4-	2	POS. 2 106145
119881	2	CARRIAGE RETURN IN "LETTERS" POSITION ONLY	74705	---4-	—	—
119882	2	CARRIAGE RETURN IN "LETTERS" AND "FIGURES"	74705	---4-	—	—
74128	3	SHIFT TO "FIGURES" POSITION	74962	12_45	3	POS. 3 74128
74138	4	BELL ON FIGURES "S"	74961	1_3_--	4	POS. 4 74138
80489	4	BELL ON FIGURES "J"	74961	12_4_--	4	POS. 4A 80489
80919	4	BELL ON "BLANK"	74961	-----	4	POS. 4B 80919
115542	4	BELL ON FIGURES "A"	74961	12_---	4	POS. 4C 115542
74109	5	RESETS SEND-RECEIVE-BREAK MECHANISM	86873	ANY SPACING CHARACTER	U	POS. 5A 74109
124421	5	RETURN RIBBON TO BLACK ON FIGURES "H"	34464	--3_5	—	UC-H 124421
84792	6	TABULATION ON FIGURES "Z"	74705	1_---5	6	POS. 6A 84792
86768	6	TABULATION ON FIGURES "G"	74705	-2_45	6	POS. 6B 86768
106144	6	AUTOMATIC CARRIAGE RETURN AND LINE FEED	74705	NONE	6	POS. 6 106144
120683	6	MOMENTARY OPERATION OF CONTACTS IN UPPER AND LOWER CASE "X"	74705	1_345	—	U & LC-X 120683
120684	6	MOMENTARY OPERATION OF CONTACTS IN UPPER AND LOWER CASE "Z"	74705	1_---5	—	U & LC-Z 120684
122874	6	STARTS OR STOPS REPERFORATOR	34464	SEE NOTE 1	—	—
124420	6	SHIFT RIBBON TO RED ON FIGURES "L"	34464	-2_--5	—	UC-L 124420
74932	7	SUPPRESSES PRINTING AND SPACING ON "BLANK"	87402	-----	7	7A
(A) (B) 84060	7	SUPPRESSES PRINTING AND SPACING ON "BLANK" IN LETTERS POSITION ONLY	4708	-----	7	7B
111015	7	STOPS REPERFORATOR ON FIGURES "H"	74962	--3_5	7	POS. 7 111015
116714	7	STOPS REPERFORATOR ON FIGURES "L"	74962	-2_--5	7	POS. 7 116714
122541	7	STOPS REPERFORATOR ON FIGURES "N"	74962	--34_	—	UC-N 122541
122542	7	STOPS REPERFORATOR ON FIGURES "V"	74962	-2345	—	UC-V 122542
126979	7	STOPS REPERFORATOR	74962	SEE NOTE 1	—	POS. 7 126979
126891	7	STOPS REPERFORATOR	74962	SEE NOTE 1	—	POS. 7
129481	9	MOMENTARY OPERATION OF CONTACTS	74962	SEE NOTE 1	—	—
74130	9	SHIFT TO LETTERS POSITION ON "SPACE"	74962	--3_--	9	POS. 9 74130
74039	10	OPERATES SEND-REC.-BRK. MECH. ON "BLANK" SIGNAL	74705	-----	10	10
74129	11	SHIFT TO "LETTERS" POSITION	74962	12345	11	POS. 11 74129
74127	12	LINE FEED	74962	-2_---	12	POS. 12 74127
(A) 84928	12	LINE FEED IN "LETTERS" POSITION ONLY	74962	-2_---	S-12	POS. 12A 84928
106279	12	LINE FEED IN "LETTERS" POSITION ONLY	74962	-2_---	—	POS. 12 106279
105274	12	LINE FEED FOR AUTOMATIC C.R. & L.F.	74962	-2_---	12	POS. 12 105274
74038	13	MOTOR STOP ON FIGURES "M"	82788	--345	13	POS. 13 74038
81784	13	MOTOR STOP ON "BLANK"	82788	-----	13	POS. 13C 81784
82271	13	MOTOR STOP ON FIGURES "H"	82788	--3_5	13	POS. 13D 82271
118484	13	MOTOR STOP ON FIGURES "F"	82788	1_34_	13	POS. 13 118484
96822	13	STARTS REPERFORATOR ON FIGURES "F"	74962	1_34_	13	POS. 13R-F 96822
98492	13	STARTS REPERFORATOR ON FIGURES "J"	74962	12_4_	—	POS. 13U-J 98492
99112	13	STARTS REPERFORATOR ON FIGURES "K"	74962	1234_	13	6G-K 99112
103300	13	STARTS REPERFORATOR ON FIGURES "M"	74962	--345	—	POS. 6 103300
116965	6 OR 13	STARTS OR STOPS REPERFORATOR	74962	SEE NOTE 1	—	—

NOTE 1: ANY CODE SELECTION MAY BE OBTAINED BY REMOVING THE PROPER KNOCKOUTS (SEE PAGE I-53)

(A) & (B) SEE SEC. IV FOR EXPLANATION

CODE BARS	
NO. STAMPED ON CODE BARS	CATALOG NO.
1D	74180
2D	74181
3D	74182
4D	74183
5N	11432

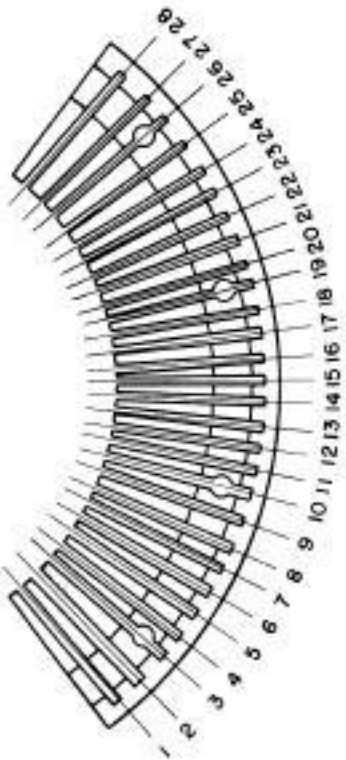

NOTE: CHECK CAREFULLY THE POSITION OF TYPE BARS IN THE SEGMENT AND THE ARRANGEMENT OF THE TYPE PALLETS ON THE TYPE BARS. IF THESE DIFFER IN ANY WAY FROM THE ARRANGEMENT SHOWN ON THIS PAGE, THE FOLLOWING PARTS SHOULD BE ORDERED BY NAME. FOR EXAMPLE ORDER:
 TYPE PALLET -----(A--)
 TYPE BAR 17 (WITH PALLET) -----(A--)
 SPRING CUSHION KEYTOP -----(A--)



NOTE: 74185 PULL BAR AND 7634 PULL BAR SPRING ARE USED IN ALL POSITIONS.

NOTE: SEE PAGE "J" FOR SAMPLE PRINTING ILLUSTRATING THE VARIOUS STYLES OF TYPE AS PRINTED.

TELETYPE ARRANGEMENT	DESCRIPTION	SETS OF TYPE PALLETS												TYPE BARS WITH PALLETS		TYPE BARS														
		MURRAY STYLE						LONG GOTHIC STYLE						GOTHIC STYLE		GOTHIC LARGE TYPE		NUMBER STAMPED ON BAR	PART NUMBER											
A -		69 TO 82	74301	69 TO 98	80858	100	82024	106	82499	69 TO 105	82750	105	82767	153	91521	230	107176	371	126747	374	126750	91057	74657	90206	84722	114840	74217	17	74217	17
A +		69 TO 82	74773	69 TO 98	80850	188	98465	100	82499	69 TO 105	82750	105	82767	153	91521	230	107176	371	126747	374	126750	91057	84743	90206	84722	114840	74217	17	74217	17
B ?		69 TO 82	74305	69 TO 98	80850	188	98465	100	82499	69 TO 105	82750	105	82767	153	91521	230	107176	371	126747	374	126750	91057	74645	90194	84710	114840	74205	5	74205	5
B %		69 TO 82	80149	69 TO 98	80850	188	98465	100	82499	69 TO 105	82750	105	82767	153	91521	230	107176	371	126747	374	126750	91057	82589	90220		114840	74205	5	74205	5
B #		69 TO 82	82176	69 TO 98	80850	188	98465	100	82499	69 TO 105	82750	105	82767	153	91521	230	107176	371	126747	374	126750	91057	82178	90226		114840	74205	5	74205	5
B 5		69 TO 82	74767	69 TO 98	80850	188	98465	100	82499	69 TO 105	82750	105	82767	153	91521	230	107176	371	126747	374	126750	91057	74843	90226		114840	74205	5	74205	5
B 5/8		69 TO 82	80862	69 TO 98	80850	188	98465	100	82499	69 TO 105	82750	105	82767	153	91521	230	107176	371	126747	374	126750	91057	82590	90226		114840	74205	5	74205	5
B ⊕		69 TO 82	82420	69 TO 98	80850	188	98465	100	82499	69 TO 105	82750	105	82767	153	91521	230	107176	371	126747	374	126750	91057	84737	90226		114840	74205	5	74205	5
C :		69 TO 82	74321	69 TO 98	80850	188	98465	100	82499	69 TO 105	82750	105	82767	153	91521	230	107176	371	126747	374	126750	91057	74661	90210	84726	114840	74221	21	74221	21
C 1/8		69 TO 82	74770	69 TO 98	80850	188	98465	100	82499	69 TO 105	82750	105	82767	153	91521	230	107176	371	126747	374	126750	91057	74847	90230		114840	74221	21	74221	21
C 1/8		69 TO 82	80865	69 TO 98	80850	188	98465	100	82499	69 TO 105	82750	105	82767	153	91521	230	107176	371	126747	374	126750	91057	82599	90230		114840	74221	21	74221	21
C O		69 TO 82	82423	69 TO 98	80850	188	98465	100	82499	69 TO 105	82750	105	82767	153	91521	230	107176	371	126747	374	126750	91057	84747	90230		114840	74221	21	74221	21
C #		69 TO 82	105343	69 TO 98	80850	188	98465	100	82499	69 TO 105	82750	105	82767	153	91521	230	107176	371	126747	374	126750	91057	74221H	90230		114840	74221	21	74221	21
D B		69 TO 82	74320	69 TO 98	80850	188	98465	100	82499	69 TO 105	82750	105	82767	153	91521	230	107176	371	126747	374	126750	91057	74660	90209	84725	114843	74220	20	74220	20
D /		69 TO 82	82148	69 TO 98	80850	188	98465	100	82499	69 TO 105	82750	105	82767	153	91521	230	107176	371	126747	374	126750	91057	84746	90209		114843	74220	20	74220	20
E 3		69 TO 82	74315	69 TO 98	80850	188	98465	100	82499	69 TO 105	82750	105	82767	153	91521	230	107176	371	126747	374	126750	91057	74655	90204	84720	114838	74215	15	74215	15
F I		69 TO 82	74322	69 TO 98	80850	188	98465	100	82499	69 TO 105	82750	105	82767	153	91521	230	107176	371	126747	374	126750	91057	74662	90211	84727	114840	74222	22	74222	22
F 1/4		69 TO 82	74771	69 TO 98	80850	188	98465	100	82499	69 TO 105	82750	105	82767	153	91521	230	107176	371	126747	374	126750	91057	74848	90223		114869	74222	22	74222	22

Code	80866	80867	80868	80869	80870	80871	80872	80873	80874	80875	80876	80877	80878	80879	80880	80881	80882	80883	80884	80885	80886	80887	80888	80889	80890	80891	80892	80893	80894	80895	80896	80897	80898	80899	80900
F 1/4																																			
F 1/8																																			
F 1/2																																			
G 1/4																																			
G 1/8																																			
G 1/2																																			
H 1/4																																			
H 1/8																																			
H 1/2																																			
I 1/4																																			
I 1/8																																			
I 1/2																																			
J 1/4																																			
J 1/8																																			
J 1/2																																			
K 1/4																																			
K 1/8																																			
K 1/2																																			
L 1/4																																			
L 1/8																																			
L 1/2																																			
M 1/4																																			
M 1/8																																			
M 1/2																																			
N 1/4																																			
N 1/8																																			
N 1/2																																			
O 1/4																																			
O 1/8																																			
O 1/2																																			
P 1/4																																			
P 1/8																																			
P 1/2																																			
Q 1/4																																			
Q 1/8																																			
Q 1/2																																			
R 1/4																																			
R 1/8																																			
R 1/2																																			
S 1/4																																			
S 1/8																																			
S 1/2																																			
T 1/4																																			
T 1/8																																			
T 1/2																																			
U 1/4																																			
U 1/8																																			
U 1/2																																			
V 1/4																																			
V 1/8																																			
V 1/2																																			
W 1/4																																			
W 1/8																																			
W 1/2																																			
X 1/4																																			
X 1/8																																			
X 1/2																																			
Y 1/4																																			
Y 1/8																																			
Y 1/2																																			
Z 1/4																																			
Z 1/8																																			
Z 1/2																																			
.																																			

TYPE BARS WITH PALLETS FOLLOW ON NEXT PAGE. ORIGINAL

LONG GOTHIC STYLE																									
DESCRIPTION	TYPE PALLET	TYPE BAR WITH PALLET	TYPE BARS		DESCRIPTION	TYPE PALLET	TYPE BAR WITH PALLET	TYPE BARS		DESCRIPTION	TYPE PALLET														
			PART NUMBER	NO. STAMPED ON BAR				PART NUMBER	NO. STAMPED ON BAR																
A 1 82289	82595	74217	17	17	D +	122903	74220C	74220	20	H %	91813	102990	74211	11	N *	74314	111745	74225A	74225	25	B 7	110910	11094	74205	5
B 1/2 89543	89541	74205	5	5	D	118054	74220D	74220	20	H %	120939	7421A	74211	11	N *	92447	94401	74225B	74225	25	B **	117150	74205A	74205	5
B MC 92445	92451	74205	5	5	F %	82177	82179	74222	22	H %	122348	7421B	74211	11	N #	99164	89353	74225C	74225	25	C B	89396	90218	74221	21
B V 97924	97926	74205	5	5	F #	83539	84748	74222	22	H %	94073	7421C	74211	11	N	11736	91527	74225D	74225	25	C **	115631	74221B	74221	21
B B 92529	98379	74205	5	5	F -	86663	88847	74222	22	J #	82025	82596	74218	18	N *	11748	122888	74225E	74225	25	C #	117158	74221G	74221	21
B @ 99526	114789	74205	5	5	F #	89325	89328	74222	22	J #	82290	82597	74218	18	N *	11747	120029	74225F	74225	25	D #	115635	74220B	74220	20
B ** 92801	74205B	74205	5	5	F *	99525	102982	74222	22	J *	84890	88848	74218	18	N %	120029	120029	74225G	74225	25	F #	115632	74222E	74222	22
B 1 99188	74205C	74205	5	5	F %	91610	91611	74222	22	J B	91013	91018	74218	18	N	99189	99189	74225H	74225	25	F #	115632	74222E	74222	22
B B 122882	74205D	74205	5	5	F %	99512	101584	74222	22	J #	99511	102984	74218	18	N	122883	122883	74225I	74225	25	F #	115632	74222E	74222	22
B) 122889	74205E	74205	5	5	F %	84687	93728	74222	22	J #	111749	114788	74218	18	N	122905	122905	74225J	74225	25	F #	115632	74222E	74222	22
C R 89222	89218	74221	21	21	F N	105333	74222C	74222	22	J GL	11762	114792	74218	18	N **	11761	11761	74225K	74225	25	F #	115632	74222E	74222	22
C % 89324	89327	74221	21	21	F 1/2	94411	74222B	74222	22	J #	87490	74218B	74218	18	S	83861	84756	74225L	74225	25	F #	115632	74222E	74222	22
C ** 91232	91233	74221	21	21	F 1/2	120937	74222A	74222	22	J #	87490	74218B	74218	18	S	89547	91578	74225M	74225	25	F #	115632	74222E	74222	22
C ? 92448	92454	74221	21	21	F @	120947	74222D	74222	22	J #	11744	74218C	74218	18	S	99513	101752	74225N	74225	25	F #	115632	74222E	74222	22
C B 99165	99168	74221	21	21	F #	122346	74222F	74222	22	J #	122909	74218D	74218	18	S	120946	74228A	74228	28	F #	115632	74222E	74222	22	
C # 120940	74221A	74221	21	21	G #	99531	102986	74224	24	L +	92446	92452	74210	10	V /	82770	84751	74225O	74225	25	F #	115632	74222E	74222	22
C # 118046	74221C	74221	21	21	G #	120938	74224A	74224	24	L GN	105337	114790	74210	10	V #	86662	88846	74225P	74225	25	F #	115632	74222E	74222	22
C C 122885	74221D	74221	21	21	G ?	120928	74224B	74224	24	L L	122884	74210A	74210	10	V W	89223	89219	74225Q	74225	25	F #	115632	74222E	74222	22
C 1/2 91526	74221E	74221	21	21	G *	122347	74224C	74224	24	M %	8201	82591	74208	8	V :	89326	89329	74225R	74225	25	F #	115632	74222E	74222	22
C 1/4 122311	74221F	74221	21	21	G	103171	74224D	74224	24	M #	82272	82592	74208	8	V #	14	89544	74225S	74225	25	F #	115632	74222E	74222	22
D % 82291	82598	74220	20	20	H 1/2	82718	84741	74211	11	M #	91875	102983	74208	8	V US	92449	92455	74225T	74225	25	F #	115632	74222E	74222	22
D ** 95171	95172	74220	20	20	H #	97925	97927	74211	11	M **	105338	114794	74208	8	V *	91814	102991	74225U	74225	25	F #	115632	74222E	74222	22
D @ 120936	74220A	74220	20	20	H B	87949	102987	74211	11	N -	81729	81730	74214	14	V LB	11764	114793	74225V	74225	25	F #	115632	74222E	74222	22

MURRAY STYLE																														
DESCRIPTION	TYPE PALLET	TYPE BAR WITH PALLET	TYPE BARS		DESCRIPTION	TYPE PALLET	TYPE BAR WITH PALLET	TYPE BARS		DESCRIPTION	TYPE PALLET																			
			PART NUMBER	NO. STAMPED ON BAR				PART NUMBER	NO. STAMPED ON BAR																					
A O 11990	C #	111741	E Y	119199	G	120036	J	120036	J	120036	J	120036	J	120036	J	120036	J	120036	J	120036	J	120036	J	120036	J	120036	J			
A L 118062	C	111756	E	120021	G	120053	J	120053	J	120053	J	120053	J	120053	J	120053	J	120053	J	120053	J	120053	J	120053	J	120053	J	120053	J	
A # 119188	C	12002	F B	99518	G	120915	J	120915	J	120915	J	120915	J	120915	J	120915	J	120915	J	120915	J	120915	J	120915	J	120915	J	120915	J	
A B 120922	C	118055	F	99523	G	122353	J	122353	J	122353	J	122353	J	122353	J	122353	J	122353	J	122353	J	122353	J	122353	J	122353	J	122353	J	
A # 120948	C	118072	F	11740	G	122876	J	122876	J	122876	J	122876	J	122876	J	122876	J	122876	J	122876	J	122876	J	122876	J	122876	J	122876	J	
A # 90277	C	119202	F	11987	G	94468	J	94468	J	94468	J	94468	J	94468	J	94468	J	94468	J	94468	J	94468	J	94468	J	94468	J	94468	J	
B # 91873	C	120025	F	118040	H	2/3	99507	J	99507	J	99507	J	99507	J	99507	J	99507	J	99507	J	99507	J	99507	J	99507	J	99507	J	99507	J
B N 99521	C	122310	F	118064	H	+	99505	K	99505	K	99505	K	99505	K	99505	K	99505	K	99505	K	99505	K	99505	K	99505	K	99505	K	99505	K
B 1/5 99532	C	120904	F	118077	H	5/8	99519	K	99519	K	99519	K	99519	K	99519	K	99519	K	99519	K	99519	K	99519	K	99519	K	99519	K	99519	K
B % 111737	C	120920	F	120026	H	3	120026	H	120026	H	120026	H	120026	H	120026	H	120026	H	120026	H	120026	H	120026	H	120026	H	120026	H	120026	H

B OZ	111766	C 3/4	120941	F X	120034	H 7	111988	K 1/2	120038	N 2	118075	Q 1	120037	V 1/4	122341	Z TAB	122918
B 1	111997	C 3/4	122343	F 1/4	120039	H 8	118049	K 3/4	120910	N 3	119185	R 1	120024	V 1/2	122342	Z 1	122879
B 1/2	118048	C 1/2	122357	F 1/2	120054	H 1	118066	K 1	120917	N 4	120906	R 2	111998	V 1/4	122354	Z 2	122887
B 3/4	118074	C 1/4	122912	F 3/4	120907	H 2	118084	K 2	122359	N 5	120913	R 3	119200	V 1/2	122902	Z 3	122897
B 1	118076	C 1/2	122898	F ON	120949	H 3	119180	K 3	122908	N 6	120919	S 1	118053	V 1/4	122913	Z 4	119189
B 1/2	118083	D 1	92441	F E	122351	H 4	120052	K 4	122905	N 7	120927	S 2	119204	V 1/2	122920	Z 5	119190
B 3/4	119182	D 1/2	99038	F FZ	122910	H 5	120055	L 1	131753	N 8	120930	S 3	120049	V 1/4	122886	Z 6	119191
B 1	120013	D 3/4	99508	F SZ	122914	H 6	120057	L 2	118069	N 9	122901	S 4	122877	V 1/2	122899	Z 7	119192
B 1/2	120912	D 1	111755	F 1	122875	H 7	122875	L 3	118079	N 10	122904	S 5	111738	V 1/4	120914	Z 8	119193
B 3/4	120926	D 1/2	112001	F 1/2	122890	H 8	122340	L 4	118079	N 11	122907	S 6	111739	V 1/2	120924	Z 9	119194
B 1	122356	D 3/4	118044	F 3/4	122895	H 9	122352	L 5	119203	N 12	122917	S 7	111760	V 1/4	120942	Z 10	119195
B 1/2	122900	D 1	118063	G %	99524	H 10	122905	L 6	120018	N 13	122919	T 1	111996	V 1/2	111994	Z 11	119196
B 3/4	122916	D 1/2	119206	G TAB	103169	H 11	122878	L 7	120060	N 14	122922	T 2	119205	V 1/4	118071	Z 12	119197
B 1	122921	D 3/4	120035	G *	111743	H 12	124687	L 8	120911	N 15	122923	T 3	120017	V 1/2	120901	Z 13	119198
B 1/2	122924	D 1	120042	G 1/2	111757	H 13	119181	L 9	120918	N 16	111746	T 4	120935	V 1/4	120903	Z 14	120925
B 3/4	122891	D 1/2	120934	G 3/4	112000	H 14	120020	L 10	120929	N 17	124690	T 5	90276	V 1/2	124688	Z 15	92443
B 1	122893	D 3/4	120944	G 1	118065	H 15	120033	L 11	122860	N 18	119187	T 6	111992	V 1/4	91874	Z 16	99516
B 1/2	90278	D 1	120945	G 1/2	120027	H 16	118042	L 12	122896	N 19	120019	T 7	119186	V 1/2	111759	Z 17	99520
B 3/4	99504	E 1	111989	G 3/4	120031	J 1	112016	L 13	103170	N 20	111993	T 8	111742	V 1/4	118038	Z 18	99528

*SPECIAL FRACTION TYPE PALLETS THAT ARE .150 IN HEIGHT

A 1	82608	B 1/2	99574	D 1	92822	F 1/4	117145	H 1/2	117243	V 1	115634
A 1/2	117972	B 3/4	96533	D 1/2	99041	F 1/2	117152	H 3/4	117242	V 1/2	115640
A 3/4	120756	B 1	113329	D 3/4	99545	F 3/4	117155	H 1	117236	V 1/4	96549
A 1	120791	C 1/2	89226	D 1	117943	F 1	117157	H 1/2	117238	V 1/2	115636
A 1/2	96523	C 3/4	91808	D 1/2	117973	F 1/2	117147	H 3/4	117247	V 3/4	115638
A 3/4	89545	C 1	91234	D 3/4	118003	F 3/4	117155	H 1	117239	V 1	117156
B 1/2	86463	C 1/2	86461	D 1	120778	F 1/4	117151	H 1/2	117249	V 1/2	96550
B 3/4	97528	C 3/4	89401	D 1/2	120786	F 3/4	117154	H 3/4	117241	V 3/4	117142
B 1	92530	C 1	92524	D 3/4	96524	F 1	117154	H 1	117238	V 1	117154
B 1/2	99543	C 1/2	91034	D 1	120733	F 1/2	117157	H 1/2	117247	V 1/2	96553
B 3/4	92802	C 3/4	123015	D 1/2	82611	F 3/4	117155	H 3/4	117236	V 3/4	117156
C 1	98190	C 1	78981	D 3/4	95173	F 1	117157	H 1	117238	V 1	117141
C 1/2	123012	C 1/2	123033	D 1	123038	G 1/4	117155	H 1/4	117246	V 1/4	96555
C 3/4	123018	C 3/4	113327	D 1/2	89404	G 1/2	117151	H 1/2	117249	V 1/2	117149
C 1	117948	C 1	91133	D 3/4	113318	G 3/4	117154	H 3/4	117241	V 3/4	117149
C 1/2	91876	C 1/2	99535	D 1	82612	G 1	117155	H 1	117236	V 1	117149
C 3/4	99566	C 3/4	113250	D 1/2	93085	G 1/2	117155	H 1/2	117238	V 1/2	117149
D 1	99593	C 1	95167	D 3/4	88851	G 3/4	117155	H 3/4	117247	V 3/4	117149
D 1/2	91810	C 1/2	117954	D 1	96598	G 1	117155	H 1	117238	V 1	117149
D 3/4	117984	C 3/4	117982	D 1/2	99575	G 1/2	117155	H 1/2	117247	V 1/2	117149
E 1	117989	C 1	95162	D 3/4	97649	G 3/4	117155	H 3/4	117241	V 3/4	117149
E 1/2	117995	C 1/2	118010	D 1	91294	G 1	117155	H 1	117238	V 1	117149
E 3/4	99447	C 3/4	120754	D 1/2	83902	G 1/2	117155	H 1/2	117249	V 1/2	117149
F 1	120745	C 1	78994	D 3/4	91032	G 3/4	117155	H 3/4	117241	V 3/4	117149
F 1/2	120750	C 1/2	120794	D 1	120790	G 1	117155	H 1	117238	V 1	117149
F 3/4	120811	C 3/4	120810	D 1/2	88878	G 1/2	117155	H 1/2	117247	V 1/2	117149
G 1	123028	C 1	123043	D 3/4	99561	G 3/4	117155	H 3/4	117241	V 3/4	117149
G 1/2	123050	C 1/2	123026	D 1	99568	G 1	117155	H 1	117238	V 1	117149
G 3/4	123057	C 3/4	96532	D 1/2	99632	G 1/2	117155	H 1/2	117249	V 1/2	117149
H 1	123059	C 1	91144	D 3/4	117940	G 3/4	117155	H 3/4	117241	V 3/4	117149

CONTINUED ON NEXT PAGE

TELETYPE ARRANGEMENT	DESCRIPTION	KEYTOPS	HP	BS	PW	BW	BY	BZ	GE	FD	CS	GF	LK	HP	+HP TO TO TO PW FD	GE TO TO TO PW GF	GE TO TO TO GF	LK TO TO TO GE	CELLULOID AT EW	
A	78946	X	X	X	X	X	X	X	X	89410	BELL SYSTEM ARRANGEMENT-D	X	X	78935	WEATHER SERVICE MAP	93731	93730	111182	KEYTOPS	88651
A 1/2	89414																			
A 3/4	78947	X	X	X	X	X	X	X	X											
B	78986																			
B 1/2	89425																			
B 3/4	78948	X	X	X	X	X	X	X	X											
C	89423																			
C 1/2	78949	X	X	X	X	X	X	X	X											
C 3/4	89415																			
D	78950	X	X	X	X	X	X	X	X											
D 1/2	78951	X	X	X	X	X	X	X	X											
D 3/4	78952	X	X	X	X	X	X	X	X											
E	89416																			
E 1/2	78952	X	X	X	X	X	X	X	X											
E 3/4	89417																			
F	78953	X	X	X	X	X	X	X	X											
F 1/2	78981	X	X	X	X	X	X	X	X											
F 3/4	82607																			
G	89418																			
G 1/2	78954	X	X	X	X	X	X	X	X											
G 3/4	78955	X	X	X	X	X	X	X	X											
H	78993																			
H 1/2	89419																			

CONTINUED ON NEXT PAGE

MISCELLANEOUS SPRING CUSHION KEYTOPS

DESCRIPTION	PART NUMBER	DESCRIPTION	PART NUMBER	DESCRIPTION	PART NUMBER	DESCRIPTION	PART NUMBER
J P $\frac{1}{2}$	120792	M B	118002	N 1/2	120753	V 1/2	117983
J P $\frac{1}{2}$	98527	M 3/8	118034	N 1/2	120765	V 1/2	117984
K P $\frac{1}{2}$	117952	M 1/2	89403	P 1/2	99560	V 1/2	91809
K P $\frac{1}{2}$	117978	N -	99534	P 1/2	120889	V 1/2	118011
K P $\frac{1}{2}$	117991	N -	89208	P 1/2	98522	V 1/2	89546
K P $\frac{1}{2}$	118013	N #	99169	S	86855	V 1/2	96493
K P $\frac{1}{2}$	99482	N -	93735	S +	123030	V 1/2	120781
K P $\frac{1}{2}$	98528	N P	97203	S %	94648	V 1/2	123056
K P $\frac{1}{2}$	120751	N Y	83904	S /	118028	V 1/2	123037
K P $\frac{1}{2}$	113345	N %	78990	S =	120814	V 1/2	123044
L +	86466	N N	95168	S @	117950	V 1/2	123027
L GN	113316	N N	123013	V /	91274	V 1/2	120793
L L	123014	N G	123049	V /	88850	V 1/2	117957
L L	99538	N P	92341	V W	89227	V 1/2	118018
L LM	113312	N -	99043	V :	96599	V 1/2	82613
L L	117979	N -	113259	V US	86482	X X	91273
L L	117992	N -	117985	V *	91811	X M	89228
L -	123006	N 1/2	118012	V LB	113311	X +	92180
L ?	120735	N 1/2	120746	V =	13252	X MO	113310
L L	118014	N 1/2	120772	V B	94496	X B	91877
L L	120771	N CG	123029	V -	89352	X	117936
L L	123024	N @	123035	V %	91528	X 1/2	117981
L L	96529	N GR	123039	V (123017	X #	120744
L L	120752	N 6, 6	123051	V +	99042	X 1/2	118017
M %	82605	N :	123054	V **	99551	X 1/2	96531
M #	82606	N 1/2	123058	V X	99569	Y #	117967
M 1	91878	N (89402	V ?	99629	Z #	89225
M P	113317	N @	98893	V)	99549	Z #	123021
M	99559	N 1/2	120775	V 7	118005	Z @	117999

MISCELLANEOUS CELLULOID KEYTOPS

DESCRIPTION	PART NUMBER	DESCRIPTION	PART NUMBER	DESCRIPTION	PART NUMBER	DESCRIPTION	PART NUMBER
A 1	99700	F	72036	H B	114992	M	78661
B 1	90282	F %	75889	H STOP	86630	M #	83862
B 1	75886	F #	83540	H 1	99704	M 1/2	99677
B 2	98499	F P	97852	H B	75891	N @	98500
B 3	99676	F ON	99211	H =	84532	N Y	72044
C 1	75701	F 1/2	114908	J %	78651	N -	75704
C 1/2	75807	F E	120834	J -	86631	N @	99698
C 1	77216	G 1/2	84531	J 1/2	114890	P 1/2	114893
C -	90283	G %	120835	J BELL	114921	S 1/2	72828
C O	98497	G 1/2	99703	J 1/2	95102	S	72049
D 1/2	75888	G **	75578	K 1/2	114891	S #	75525
D 1/2	99701	G	86841	K No	79652	S /	75894
D	84530	G 1/2	99689	L 1/2	114892	S B	78646
F 1/2	78648	G N	114919	M %	72043	U %	90281
F 1/2	99702	H 1/2	78650	M	75893	V 1/2	75702

SETS OF KEYTOPS
SPRING CUSHION

TELETYPE ARRANGEMENT	DESCRIPTION	KEYTOPS	HP	BS	PW	BW	BY	BZ	GE	FD	CS	GF	LK	HP TO PW	HP TO FD	90101 WEATHER MAP SERVICE	GE TO PW	GE TO GF	LK TO GE	CELLULOID	AT	EW
	K 1	78956	X	X	X	X	X	X	X		X	X	X	X			93730	93731	11182	KEYTOPS	75851	88651
	K 1/2	78988	X	X	X	X	X	X	X		X	X	X	X						72041		X
	K 1/2	89420								X						X				75653	X	
	L 1	78957	X	X	X	X	X	X	X		X	X	X	X						72042		X
	L 1/2	78983								X										75654	X	
	L 1/2	89421																				
	M -	78958	X	X	X	X	X	X	X													
	N -	78959	X	X	X	X	X	X	X													
	N 1/2	78987																				
	N @	89426								X						X						
	O 9	78960	X	X	X	X	X	X	X													
	P 0	78961	X	X	X	X	X	X	X													
	P 1/2	99564																				
	Q 1	78962	X	X	X	X	X	X	X													
	R 4	78963	X	X	X	X	X	X	X													
	S BELL	78980	X	X	X	X	X	X	X													
	T 5	78964	X	X	X	X	X	X	X													
	U 7	78965	X	X	X	X	X	X	X													
	V 1	78966	X	X	X	X	X	X	X													
	V 1/2	78985																				
	V 1/2	89424																				
	W 2	78967	X	X	X	X	X	X	X							X						
	X /	78968	X	X	X	X	X	X	X													
	Y 6	78969	X	X	X	X	X	X	X													
	Z P	78970	X	X	X	X	X	X	X													
	Z +	89422																				
	-	78979																				
	-	89413																				
	BLANK FIGS.	78971	X	X	X	X	X	X	X		X											
	LTRS.	78972	X	X	X	X	X	X	X													
	CAR. RET.	78973	X	X	X	X	X	X	X													
	LINE FEED	78976	X	X	X	X	X	X	X													
		78978	X	X	X	X	X	X	X													

† 113749 MODIFICATION KIT: TO CONVERT BELL SYSTEM KEYBOARD ARRANGEMENT FROM "A" TO "D" USE 90101 SET OF SPRING CUSHION KEYTOPS, 74762 KEYLEVER, 2565 KEYLEVER SPRING, AND 89413 SPRING CUSHION KEYTOP FOR USE IN BLANK POSITION.

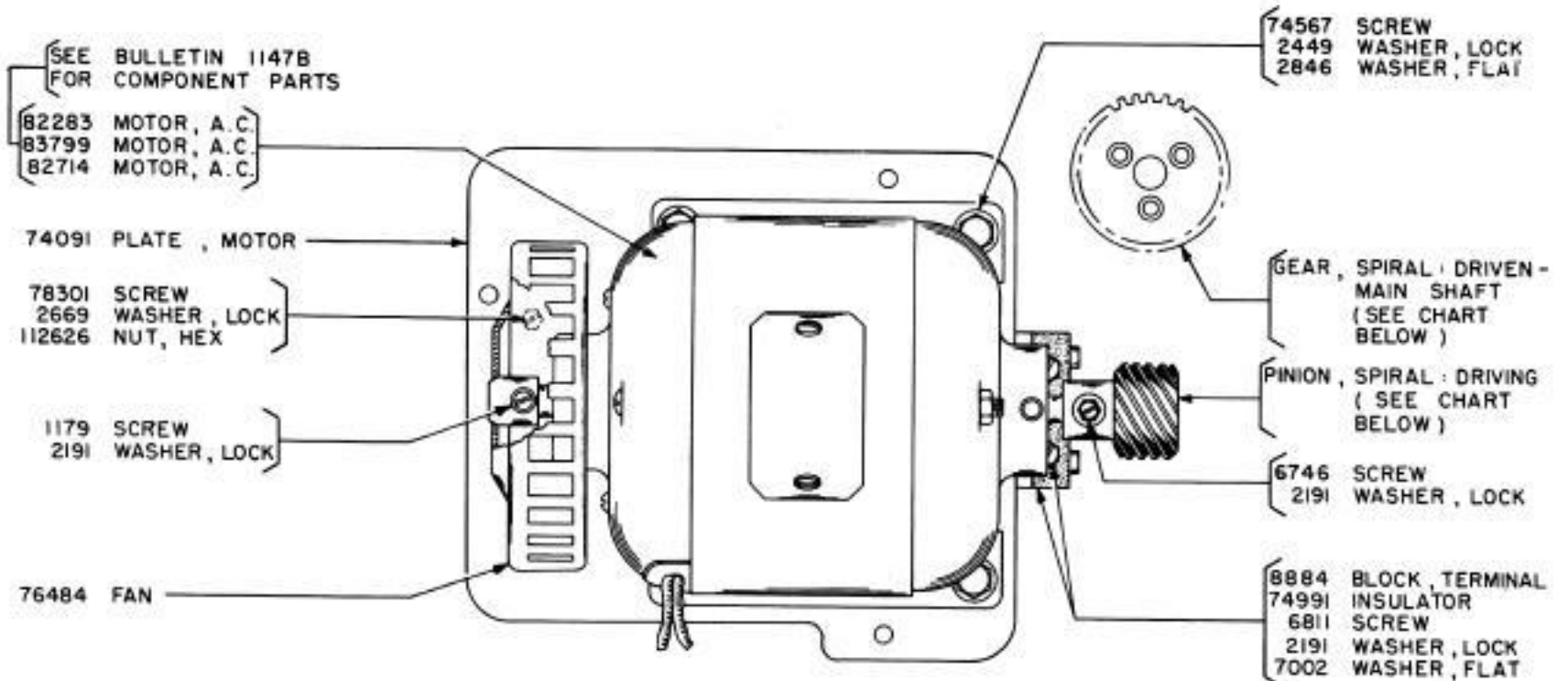

MU4 MOTOR UNIT (BELL SYSTEM 15D) - INCLUDES 82283 SYNCHRONOUS MOTOR, 60 CYCLE A. C.
 MU7 MOTOR UNIT (BELL SYSTEM 15M) - INCLUDES 83799 SYNCHRONOUS MOTOR, 60 CYCLE A. C.
 MU8 MOTOR UNIT (BELL SYSTEM 15E) - INCLUDES 82714 SYNCHRONOUS MOTOR, 50 CYCLE A. C.
 (PINION AND GEAR NOT INCLUDED WITH ABOVE MOTOR UNITS)

GEAR AND MOTOR PINION COMBINATIONS
 USED WITH GOVERNED AND SYNCHRONOUS MOTORS

SET NUMBER	BELL CODE	GEARS				OPERATIONS PER MINUTE	WORDS PER MINUTE	MOTOR DATA				TYPE OF MOTOR
		MAIN PART NO.	GEAR TEETH	MOTOR PART NO.	PINION TEETH			TARGET		SPEED INDICATOR		
								PART NO.	SPOTS	PART NO.	V. P. S.	
80437	15C	74913	30	74912	7	368	60	—	—	—	—	110V. 60 CYCLE - SYNCHRONOUS
96535	15G	91287	24	91286	7	460	75	—	—	—	—	
84042	15E	84019	25	84018	7	368	60	—	—	—	—	
107474	—	107460	20	107461	7	460	75	—	—	—	—	110V. 50 CYCLE - SYNCHRONOUS
84042	—	84019	25	84018	7	368	60	—	—	—	—	110V. 25 CYCLE - SYNCHRONOUS
107474	—	107460	20	107461	7	460	75	—	—	—	—	
80374	15A	74151	35	74505	7	368	60	7105	10	103628	87.6	110V. A. C. SERIES
96536	15H	84106	32	84105	8	460	75	7105	10	103628	87.6	
80374	—	74151	35	74505	7	368	60	7105	10	103628	87.6	
96536	—	84106	32	84105	8	460	75	7105	10	103628	87.6	110V. D. C. SHUNT
80374	—	74151	35	74505	7	368	60	7105	10	103628	87.6	220V. D. C. SHUNT
96536	—	84106	32	84105	8	460	75	7105	10	103628	87.6	

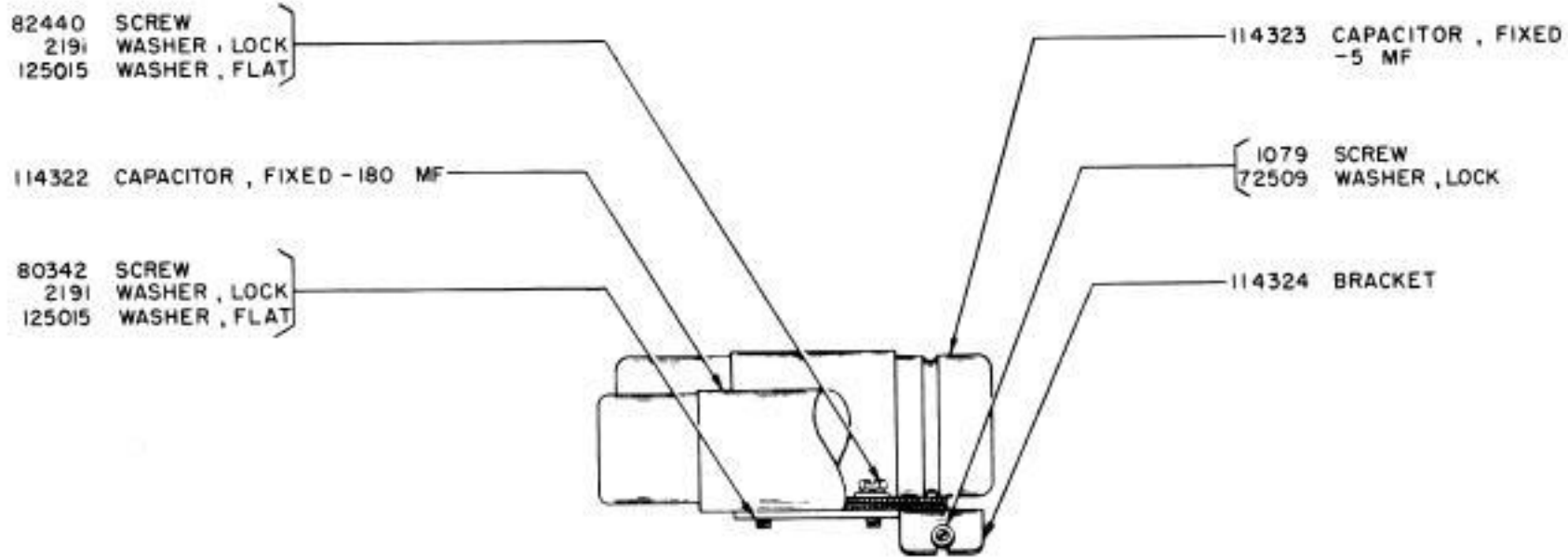

CAPACITOR PARTS USED ON MU33 ONLY

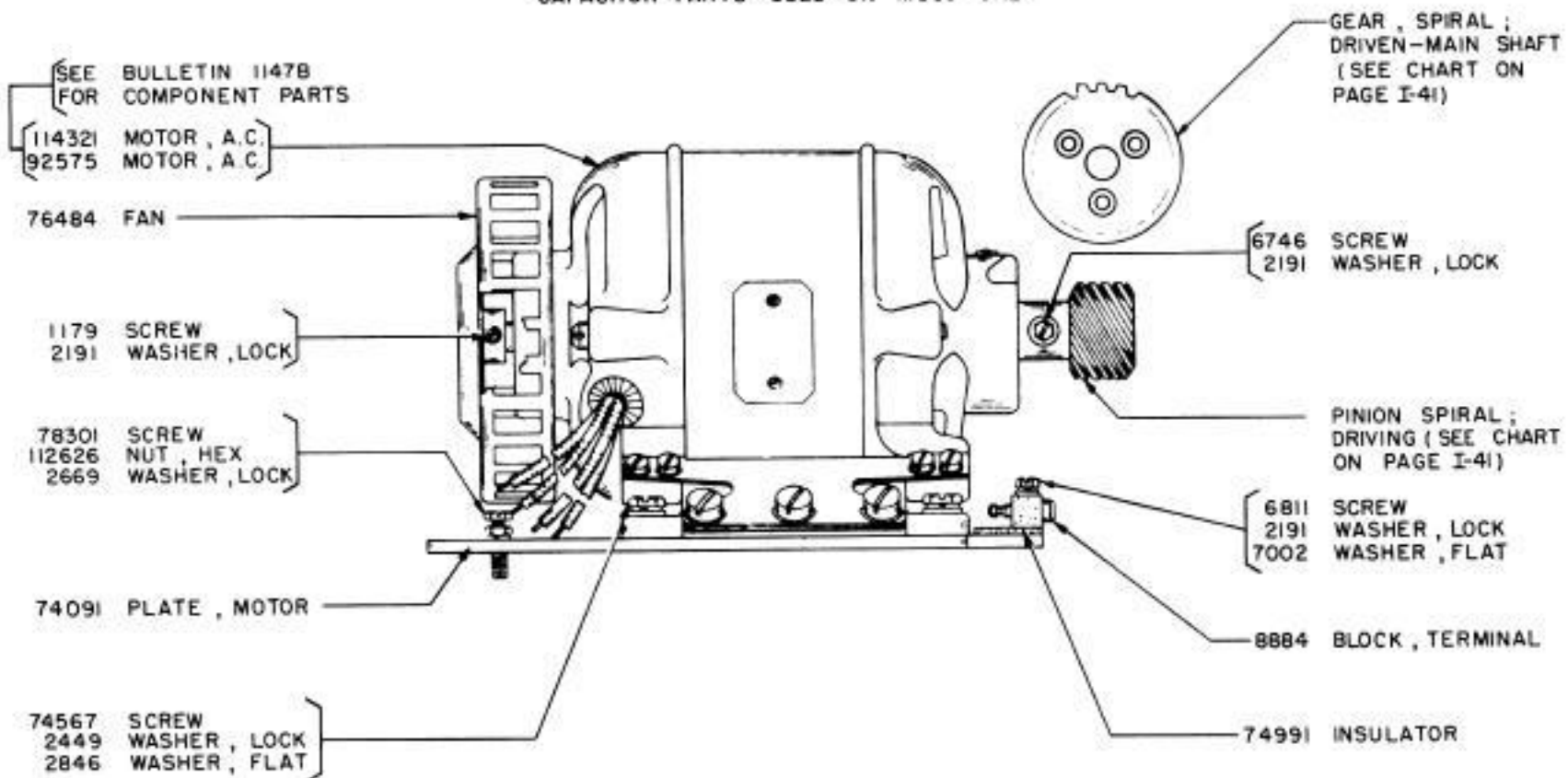

MUI5 MOTOR UNIT (BELL SYSTEM 15L) INCLUDES 92575 SYNCHRONOUS MOTOR, 60 CYCLE A.C. (*93854 SYNCHRONOUS MOTOR, 60 CYCLE A.C.)

MU33 MOTOR UNIT-INCLUDES 114321 SYNCHRONOUS MOTOR, 25 CYCLE A.C. (PINION AND GEAR NOT INCLUDED WITH ABOVE MOTOR UNITS)

* SAME AS 92575 EXCEPT EQUIPPED WITH AN ADDITIONAL 89946 (BELL SYSTEM SERVICE) NAME PLATE AND 78025 NAME PLATE MOUNTING SCREWS

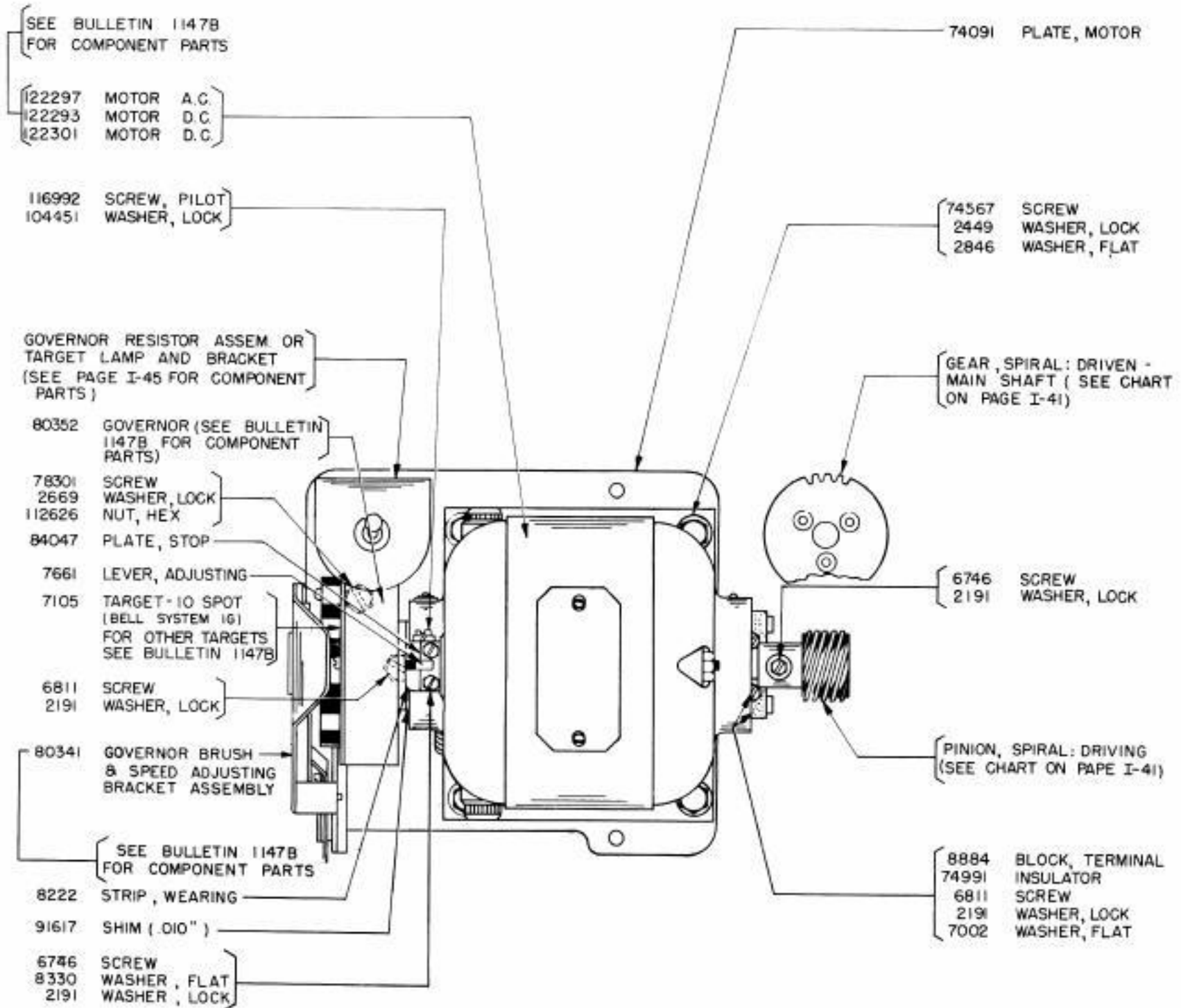

- MU1 MOTOR UNIT (BELL SYSTEM 15A) - INCLUDES 122297 GOVERNED MOTOR, 60 CYCLE A.C. SERIES
- ① MU3 MOTOR UNIT (BELL SYSTEM 15C) - INCLUDES 122297 GOVERNED MOTOR, 60 CYCLE A.C. SERIES
- MU12 MOTOR UNIT (BELL SYSTEM 15J) - INCLUDES 122297 GOVERNED MOTOR, 60 CYCLE A.C. SERIES
- MU27 MOTOR UNIT - INCLUDES 122297 GOVERNED MOTOR, 60 CYCLE A.C. SERIES
- MU32 MOTOR UNIT - INCLUDES 122297 GOVERNED MOTOR, 60 CYCLE A.C. SERIES
- MU2 MOTOR UNIT (BELL SYSTEM 15B) - INCLUDES 122293 GOVERNED, 110V. D.C. SHUNT
- MU11 MOTOR UNIT (BELL SYSTEM 15K) - INCLUDES 122293 GOVERNED, 110V. D.C. SHUNT
- MU28 MOTOR UNIT INCLUDES 122293 GOVERNED MOTOR, 110V. D.C. SHUNT
- MU35 MOTOR UNIT INCLUDES 122293 GOVERNED MOTOR, 110V. D.C. SHUNT
- MU5 MOTOR UNIT INCLUDES 122301 GOVERNED MOTOR, 220V. D.C. SHUNT

(PINION AND GEAR NOT INCLUDED WITH ABOVE MOTOR UNITS)
 (SEE PAGES I-44 & I-45 FOR ACCESSORIES USED ON ABOVE MOTOR UNITS)

① SEE SEC. IV FOR EXPLANATION

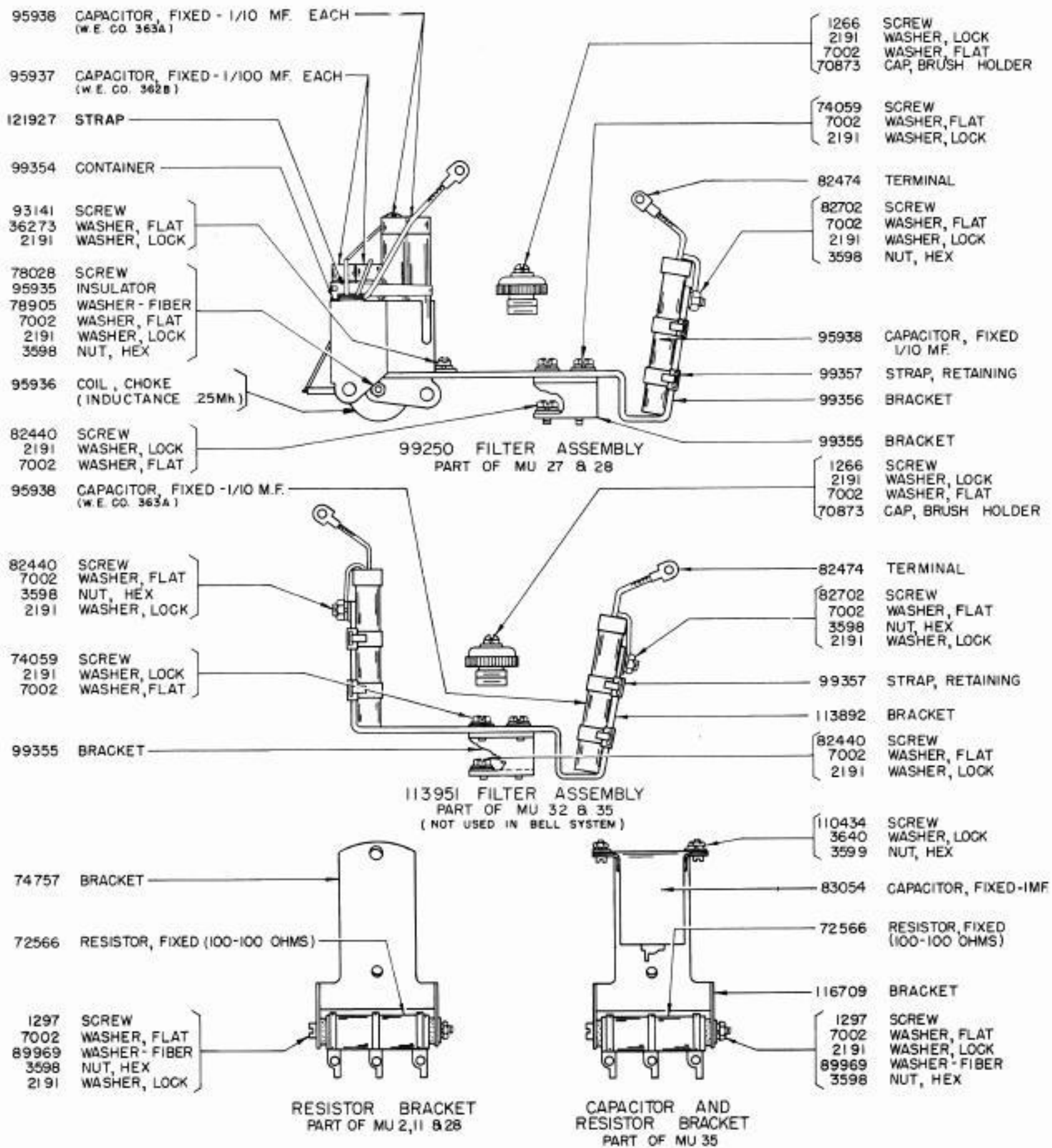

VARIABLE FEATURES OF MOTOR UNITS
MU 2, 11, 27, 28, 32 & 35

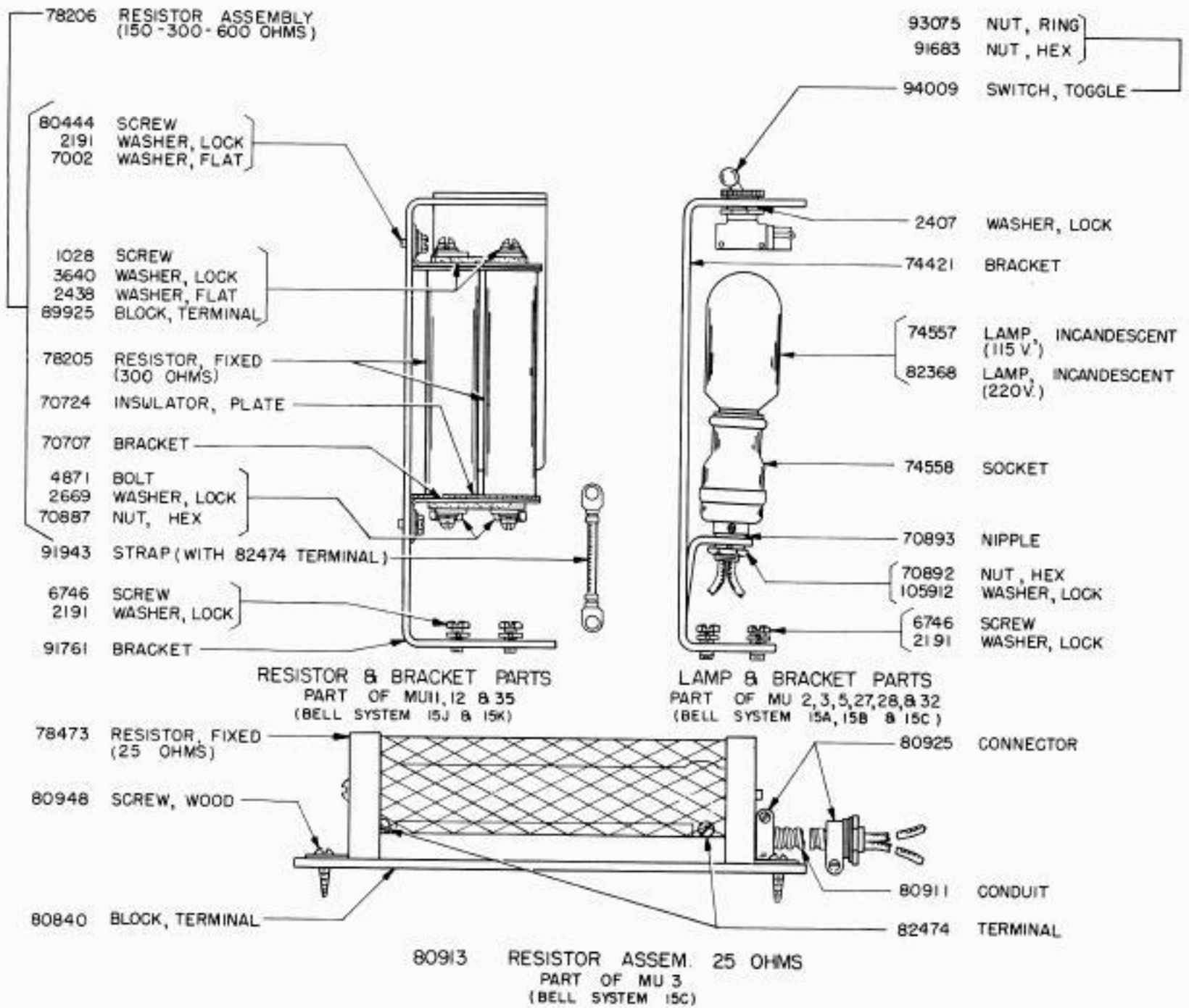

CABLE ASSEMBLY CHART		
MOTOR UNIT USED ON	CABLE ASSEMBLY NO	WIRING DIAGRAM
MU 1 (BELL SYSTEM 15A)	74788	1277 WD
MU 2 (BELL SYSTEM 15B)	74571	1277 WD
MU 3 (BELL SYSTEM 15C)	74788	1297 WD
MU 4 (BELL SYSTEM 15D)	NONE	1297 WD
MU 5	74571	1297 WD
MU 7 (BELL SYSTEM 15M)	NONE	1221 WD
MU 8 (BELL SYSTEM 15E)	NONE	1277 WD
MU 11 (BELL SYSTEM 15K)	91763	1620 WD
MU 12 (BELL SYSTEM 15J)	91762	1620 WD
MU 15 (BELL SYSTEM 15L)	NONE	1277 WD
MU 27	74788	2143 WD
MU 28	74571	2143 WD
MU 32	74788	2386 WD
MU 33	NONE	1620 WD
MU 35	115586	2422 WD

VARIABLE FEATURES OF MOTOR UNITS
MU 1, 2, 3, 5, 11, 12, 27, 28, 32 & 35

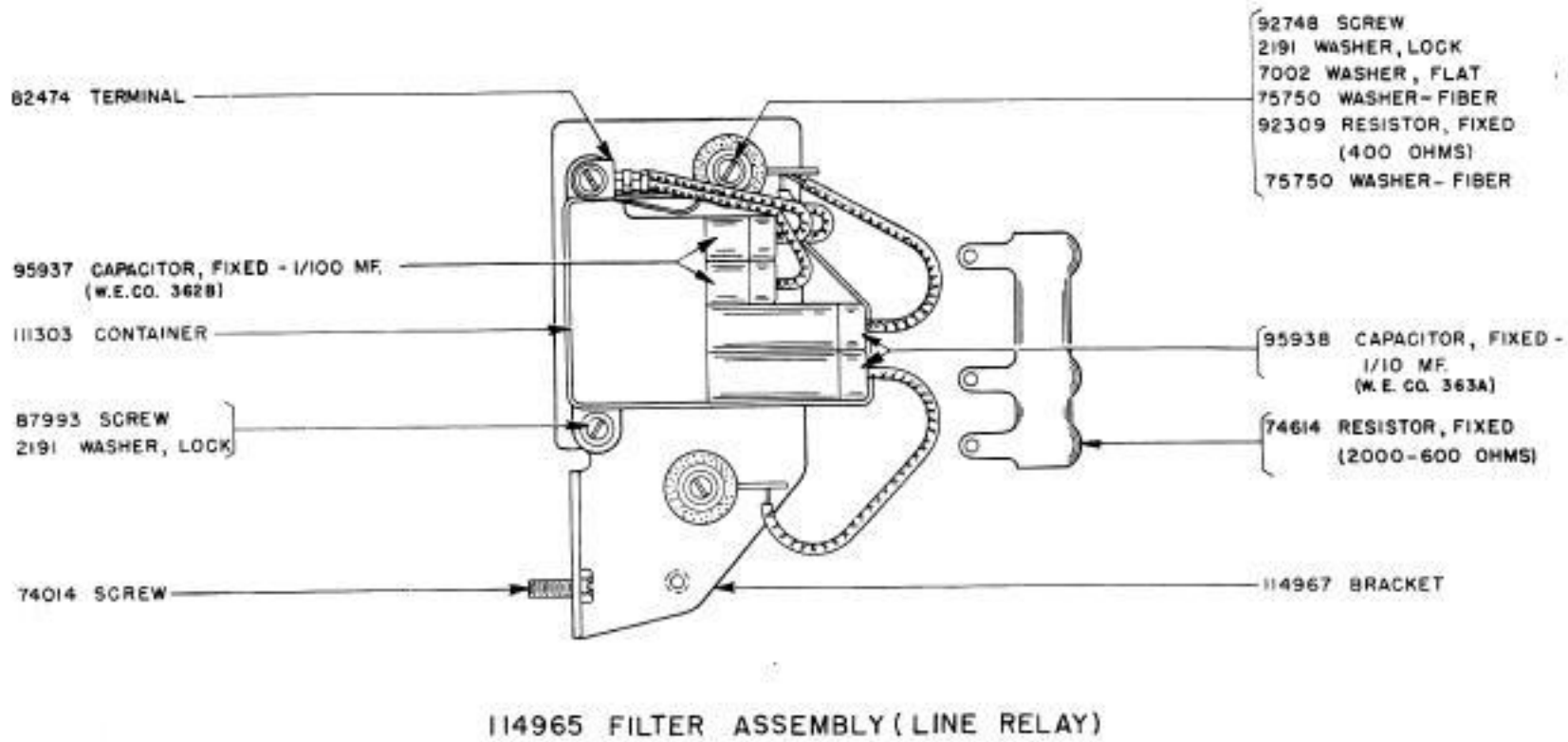
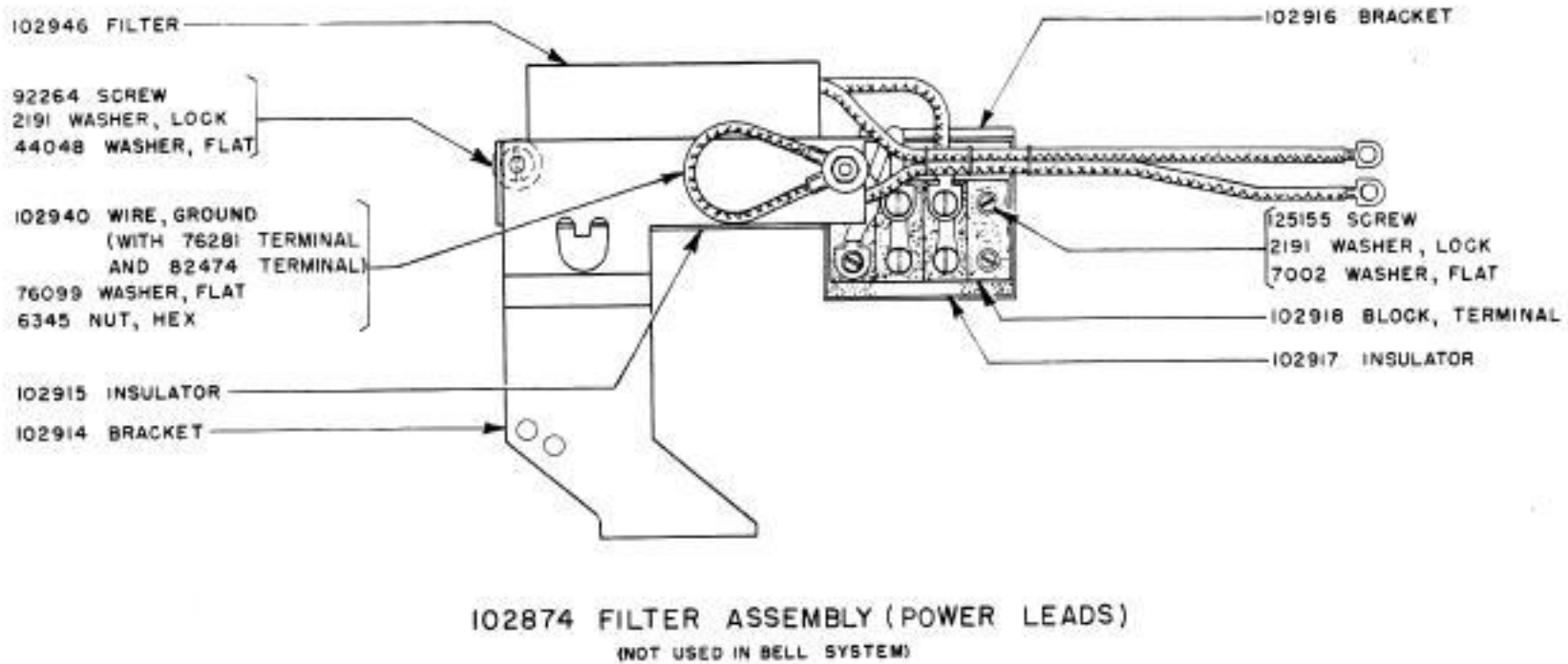
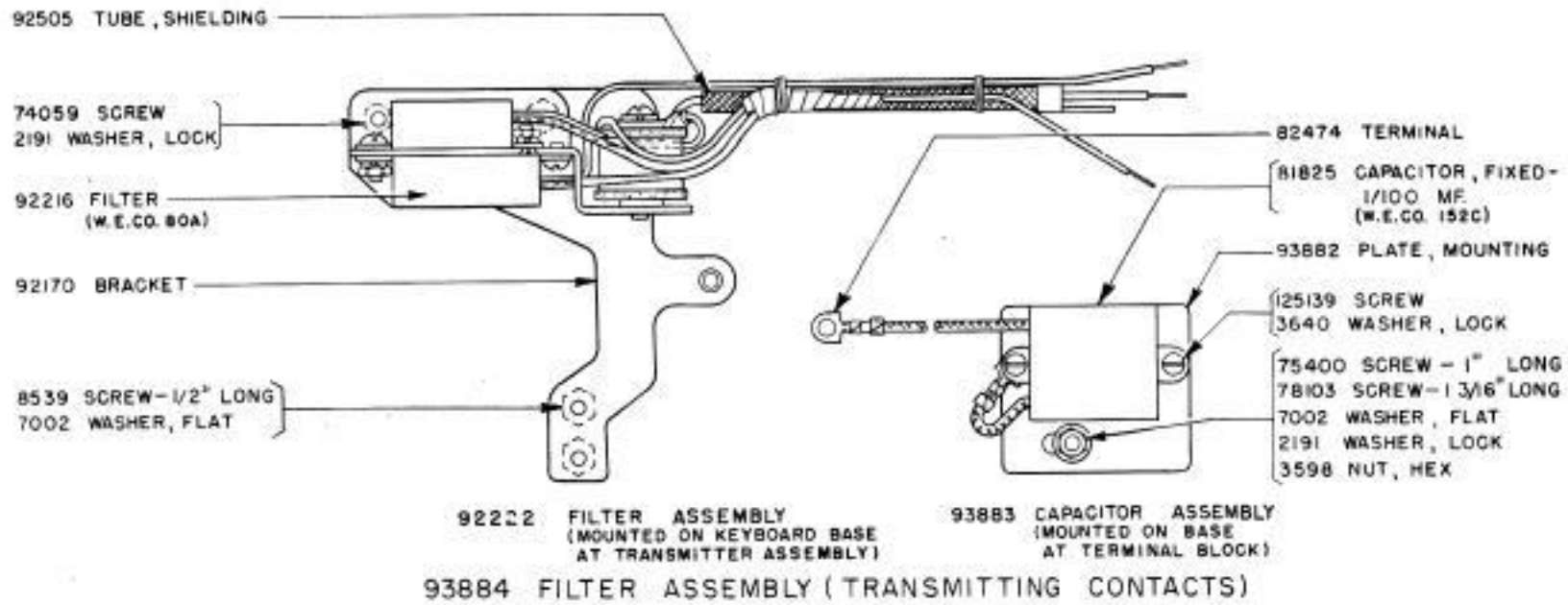

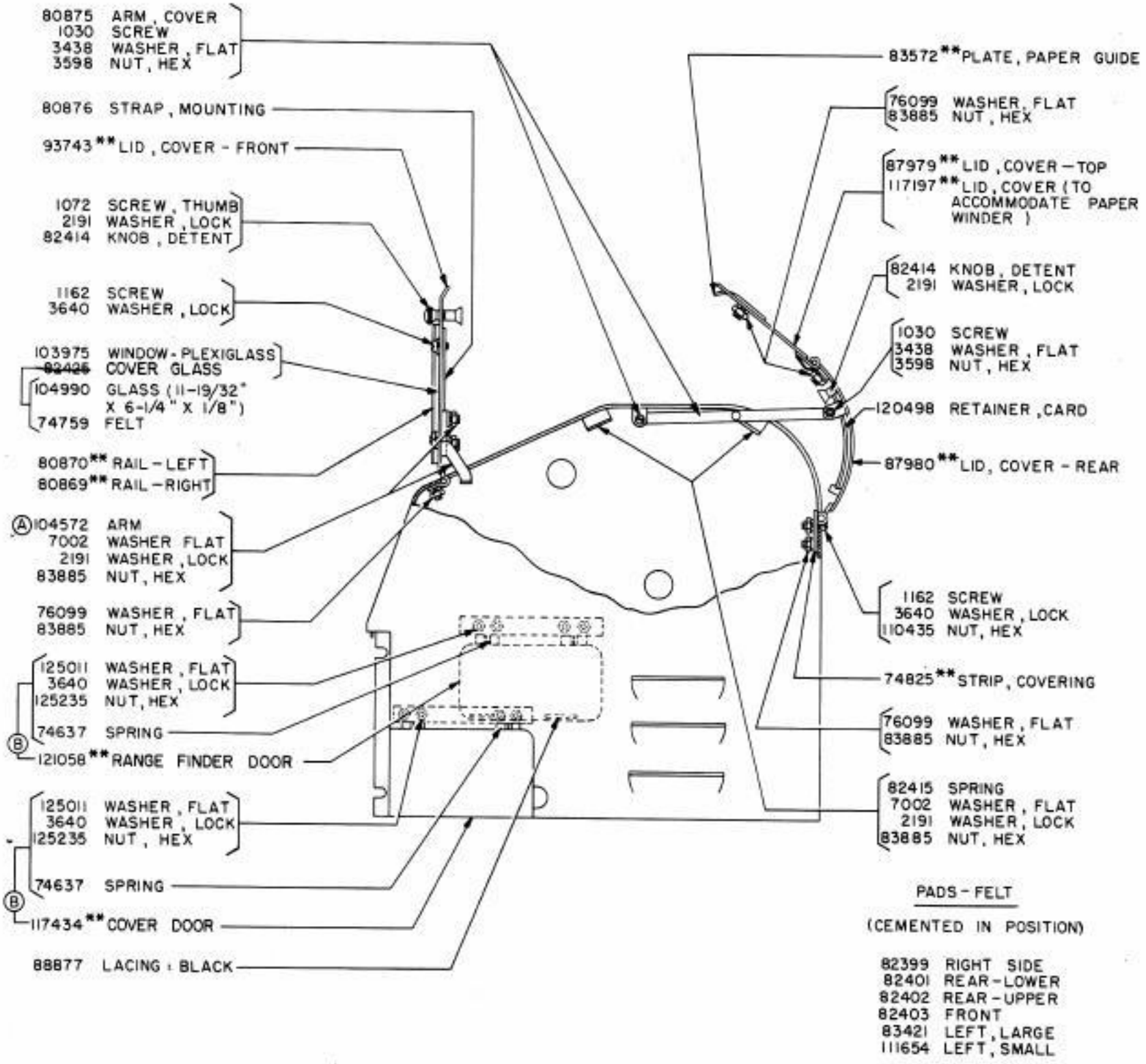

BPC200 ** COVER ASSEMBLY
(BELL SYSTEM 15C **)

** SEE SEC. IV, PAGE 4 FOR EXPLANATION
(A) & (B) SEE SEC. IV FOR EXPLANATION

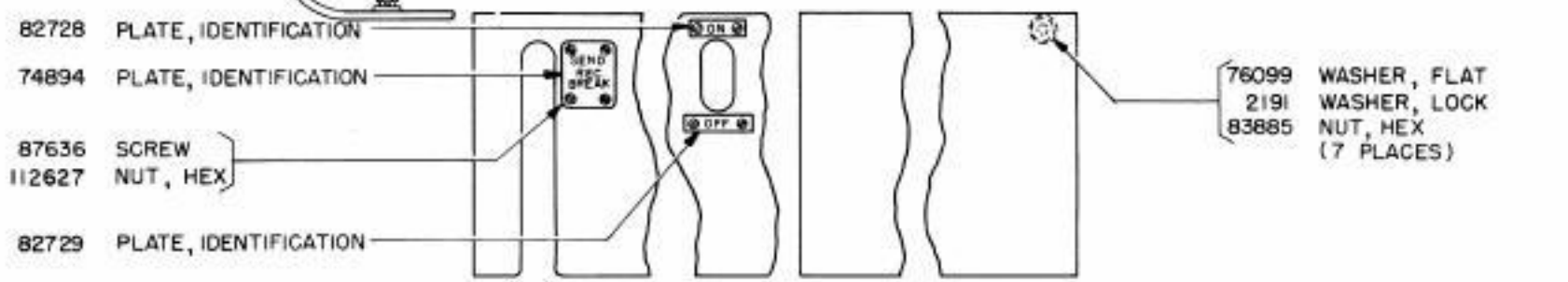
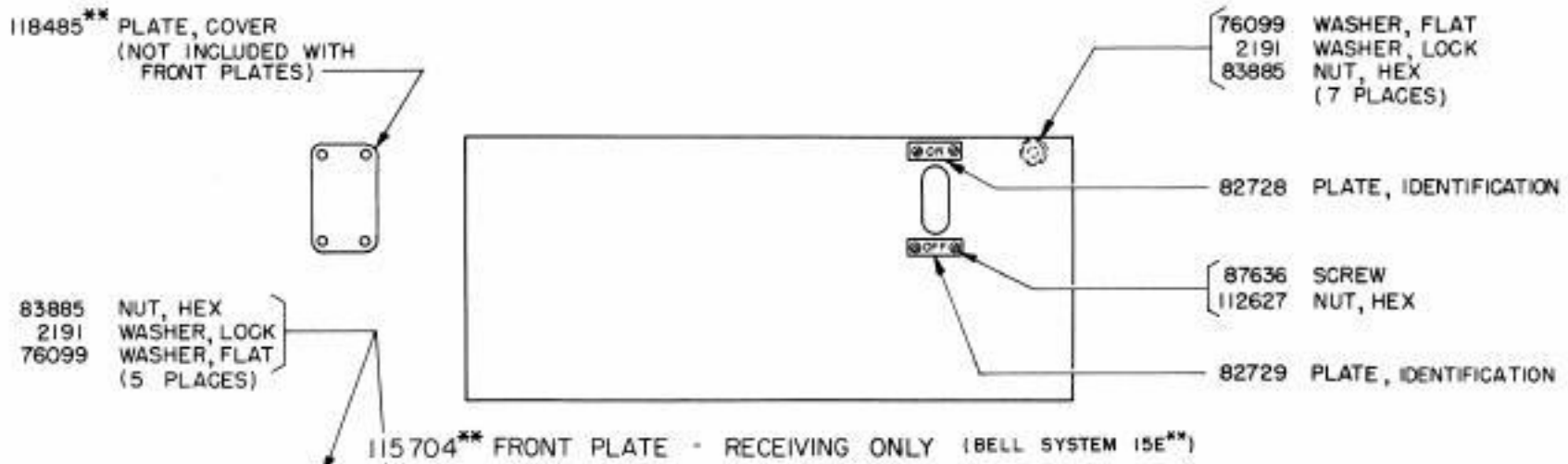
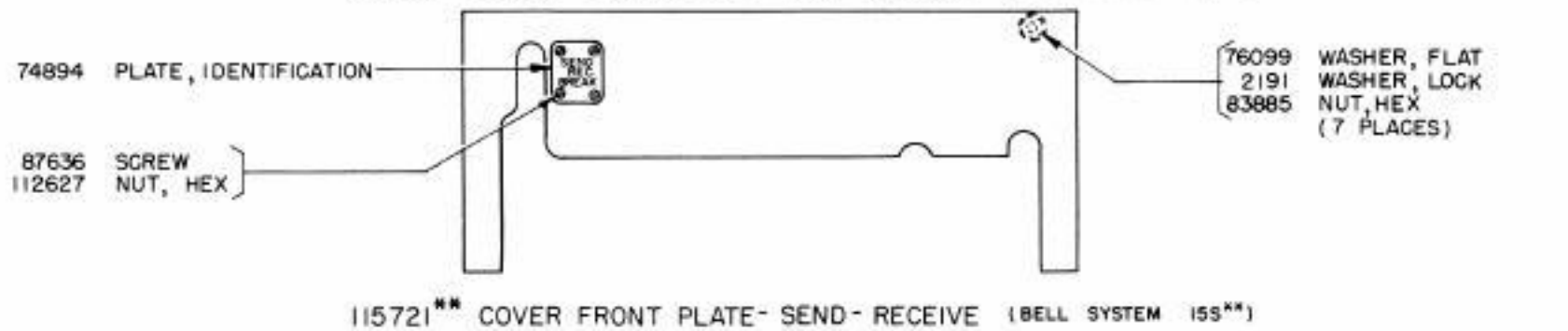
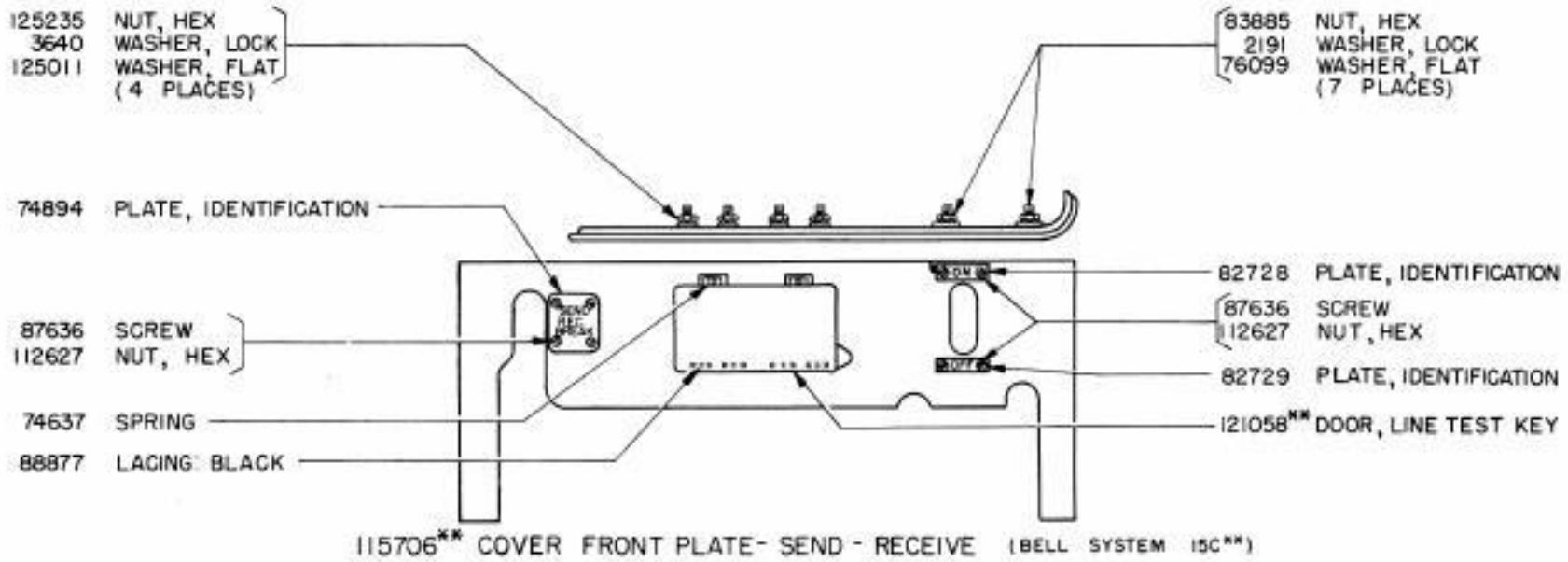

**SEE SEC. IX, PAGE 4 FOR EXPLANATION

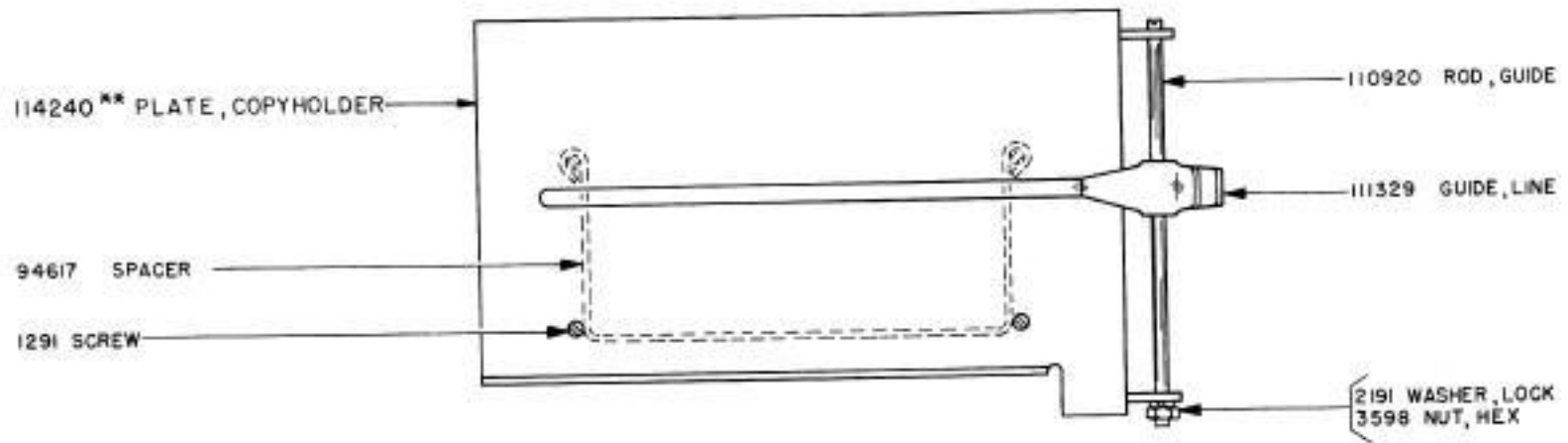

115700** COPYHOLDER ASSEMBLY - 6" (NEW STYLE)
 (BELL SYSTEM 14A**)
 SEE SEC.III,PAGE 2 FOR OLD STYLE

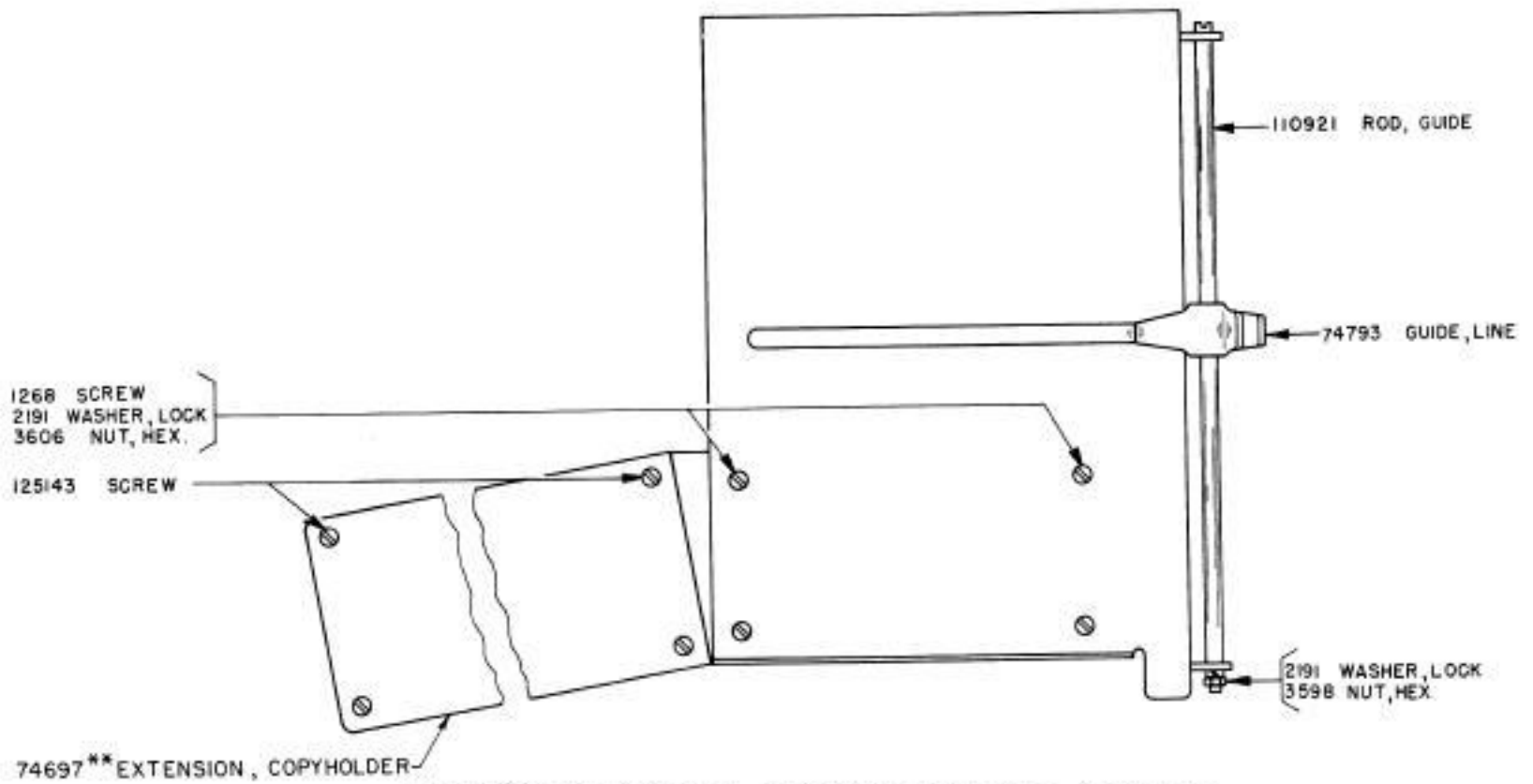

115709** COPYHOLDER ASSEMBLY - 12" (NEW STYLE)
 (BELL SYSTEM 15A**)
 SEE SEC.III,PAGE 2 FOR OLD STYLE

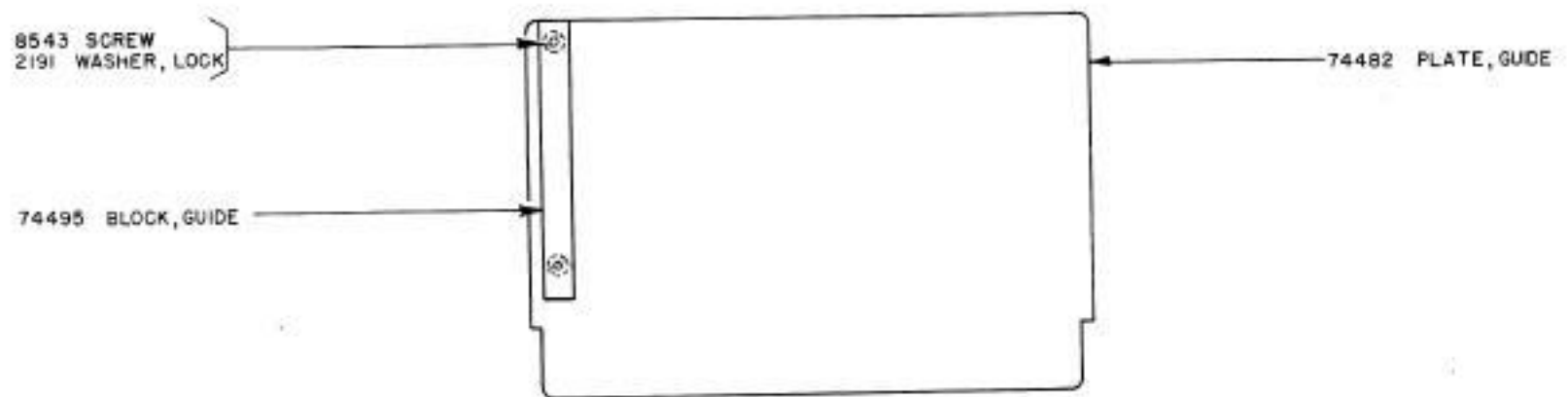

74624 BLANK GUIDE ASSEMBLY

** SEE SEC. IV , PAGE 4 FOR EXPLANATION

ORIGINAL

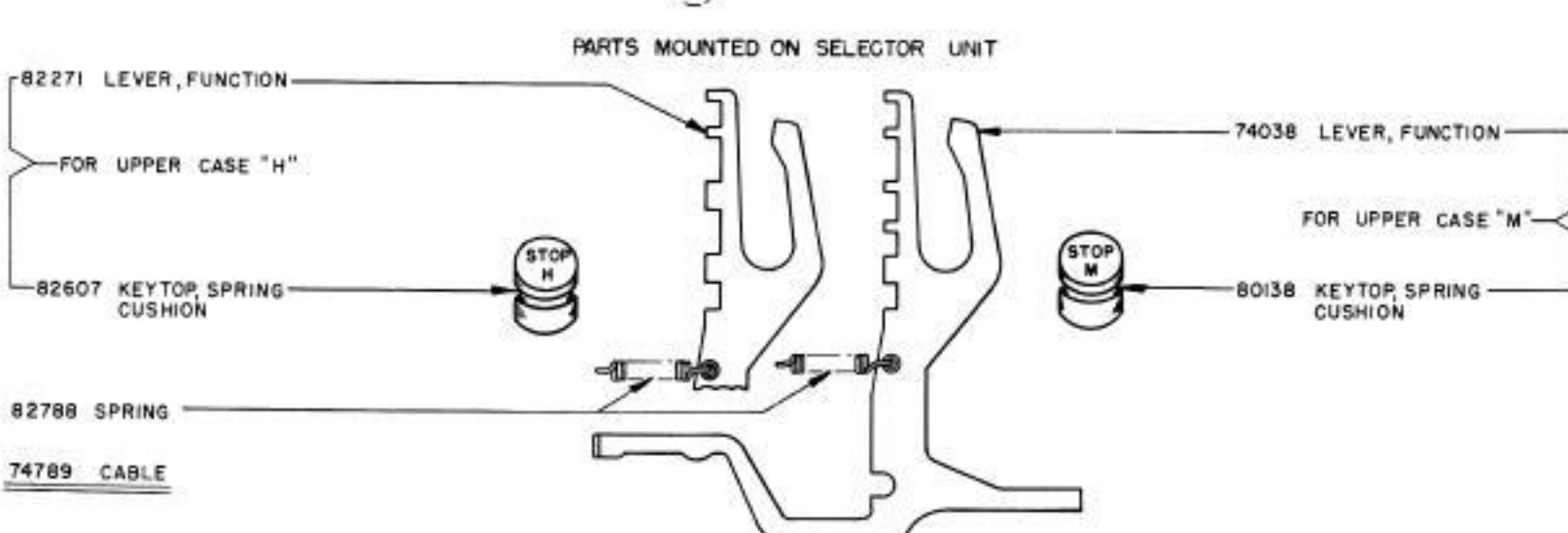
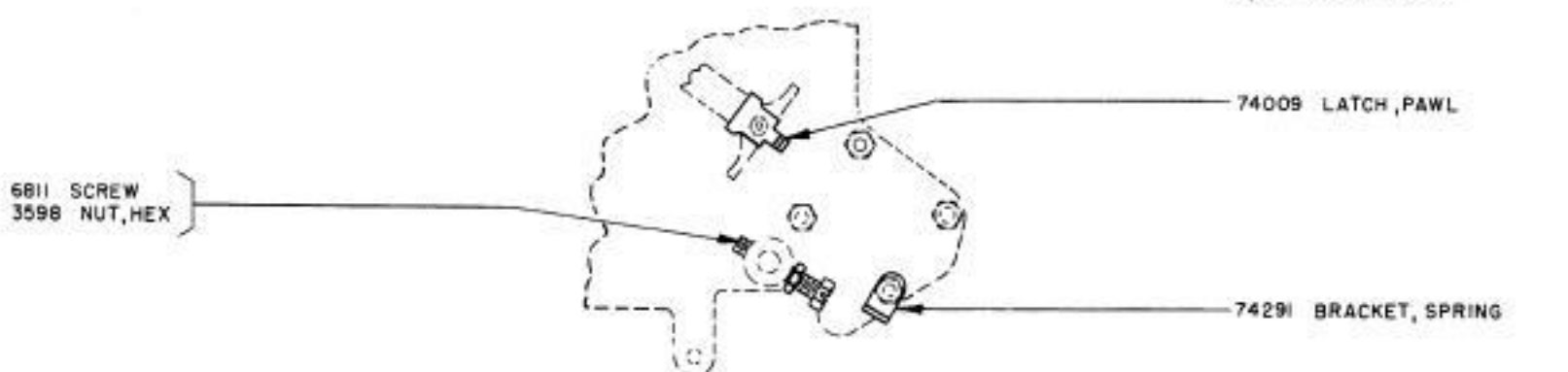
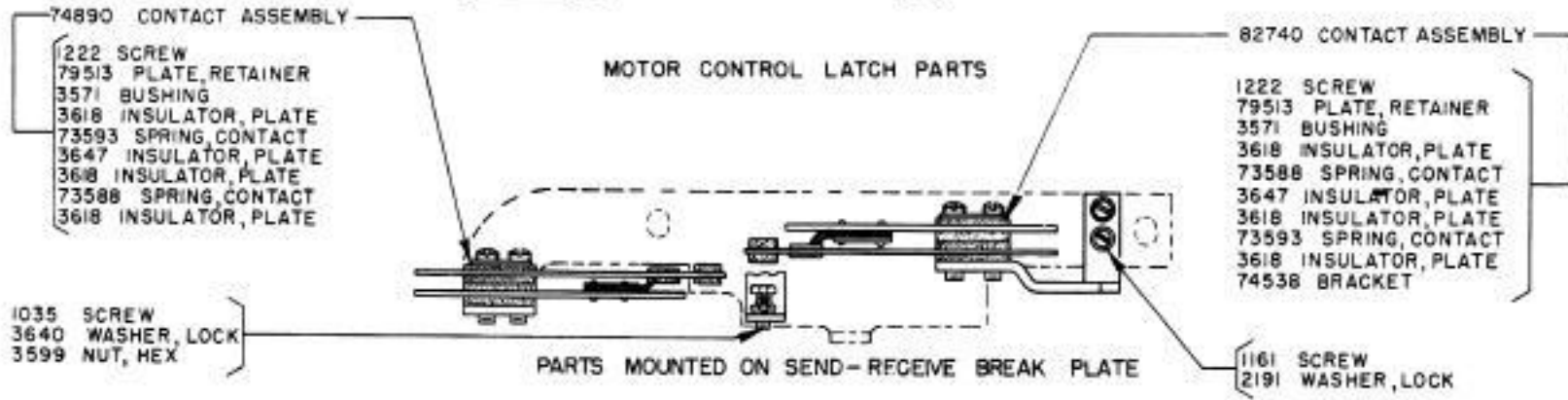
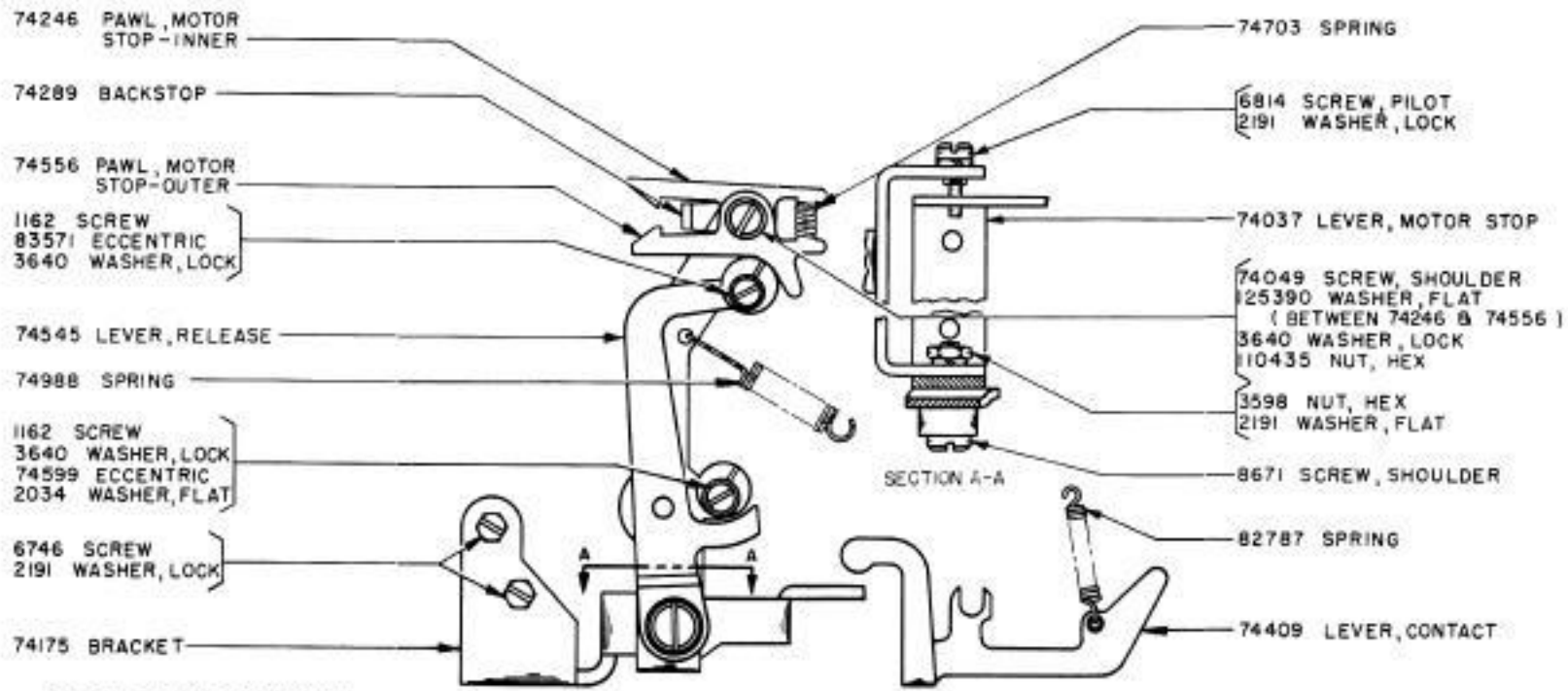

SET OF PARTS FOR MECHANICAL MOTOR CONTROL
 74764 FOR UPPER CASE "M"
 82742 FOR UPPER CASE "H"

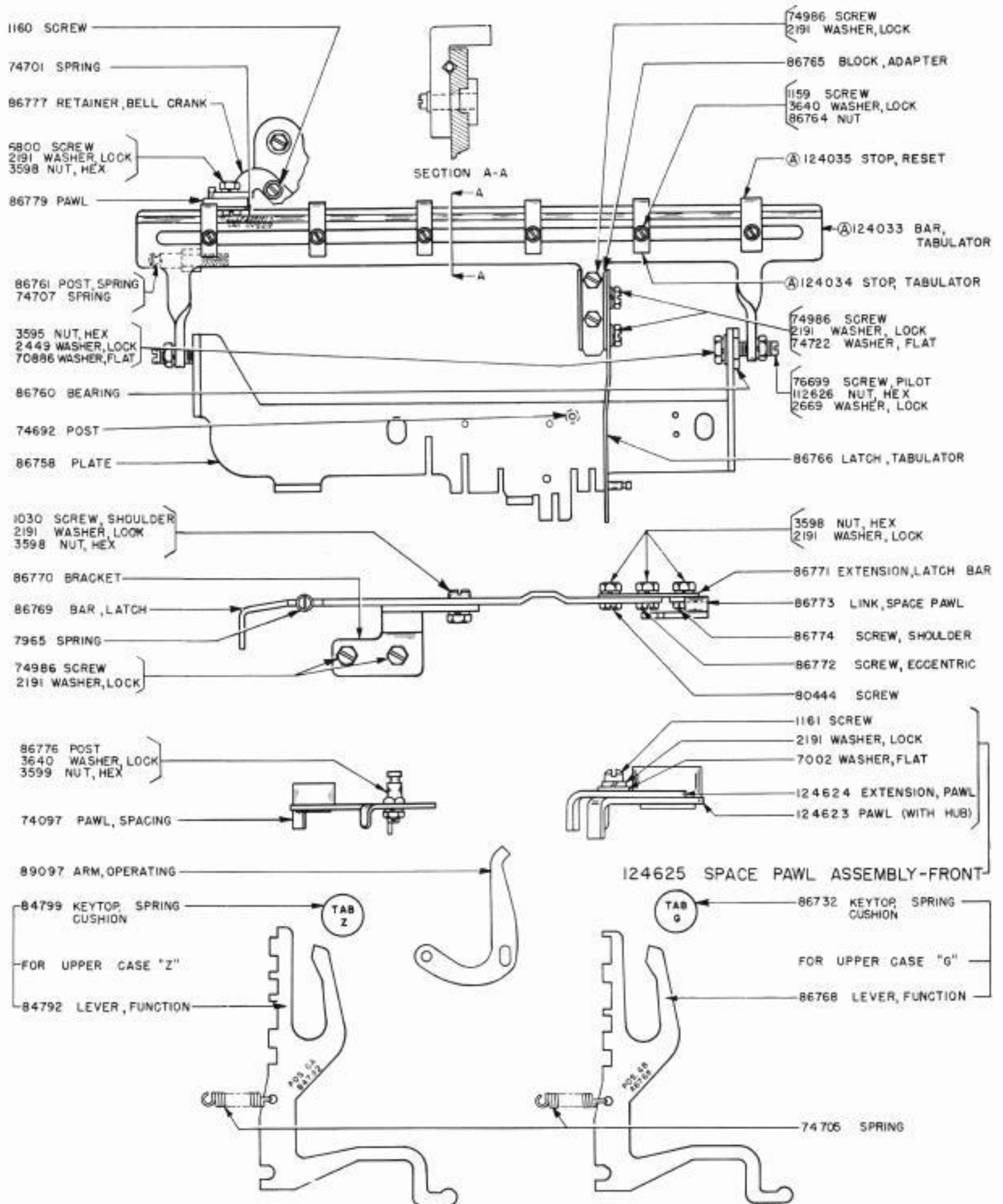

SET OF PARTS FOR HORIZONTAL TABULATOR

- 84925 FOR UPPER CASE "G"
- 87860 FOR UPPER CASE "Z"

(A) SEE SEC. IV FOR EXPLANATION

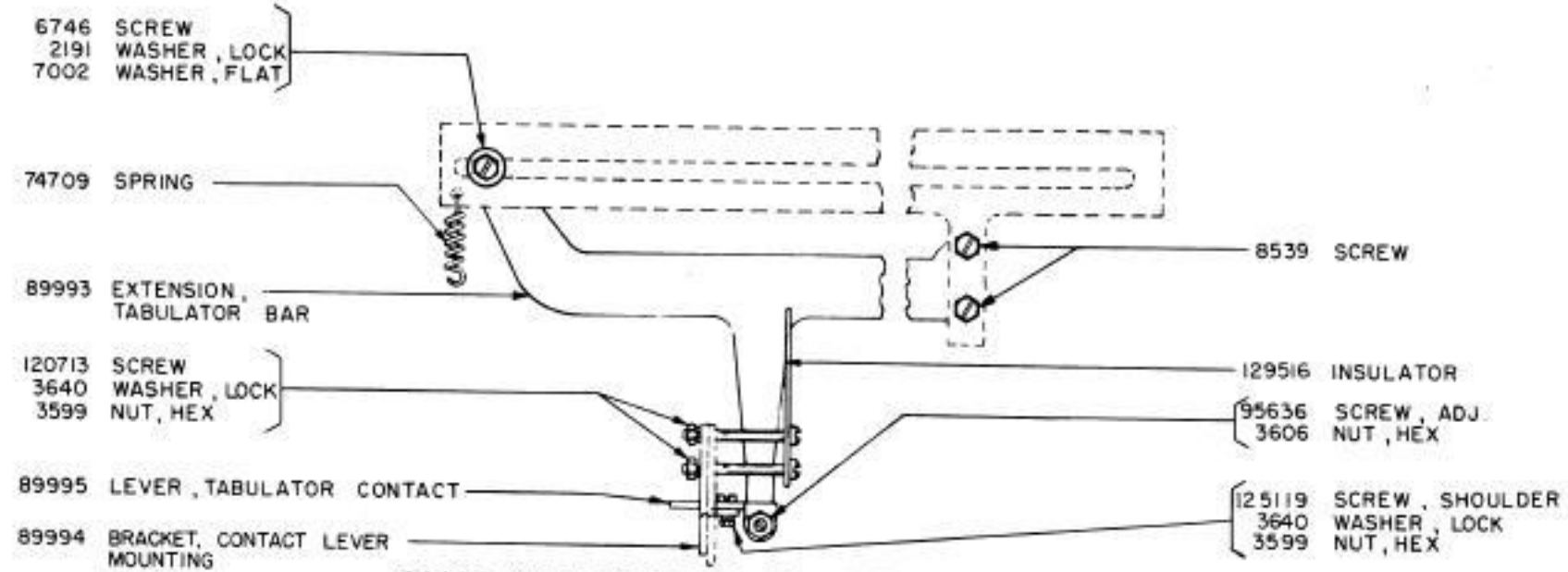

89992 SET OF PARTS TO CONTROL TRANSMITTER DISTRIBUTOR (XD) FROM TABULATOR

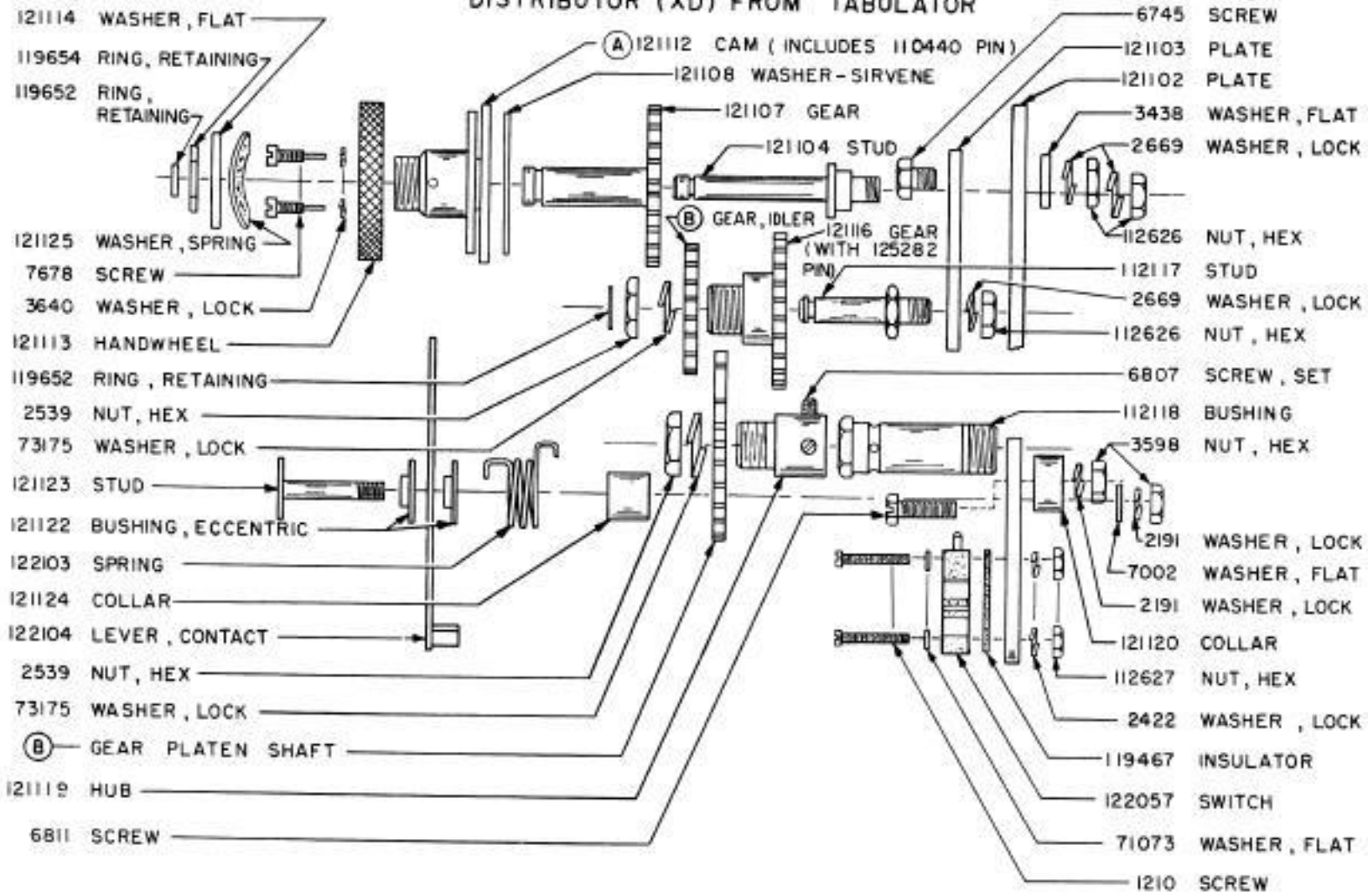

121130 SET OF PARTS TO PROVIDE PLATEN INDEXING FEATURE ON SPROCKET FEED PRINTER

(A) SEE SEC. IV FOR EXPLANATION

(B) SETS OF GEARS AVAILABLE FOR VARIOUS LENGTHS OF FORMS ARE LISTED IN SECTION IV AND MUST BE ORDERED SEPARATELY.

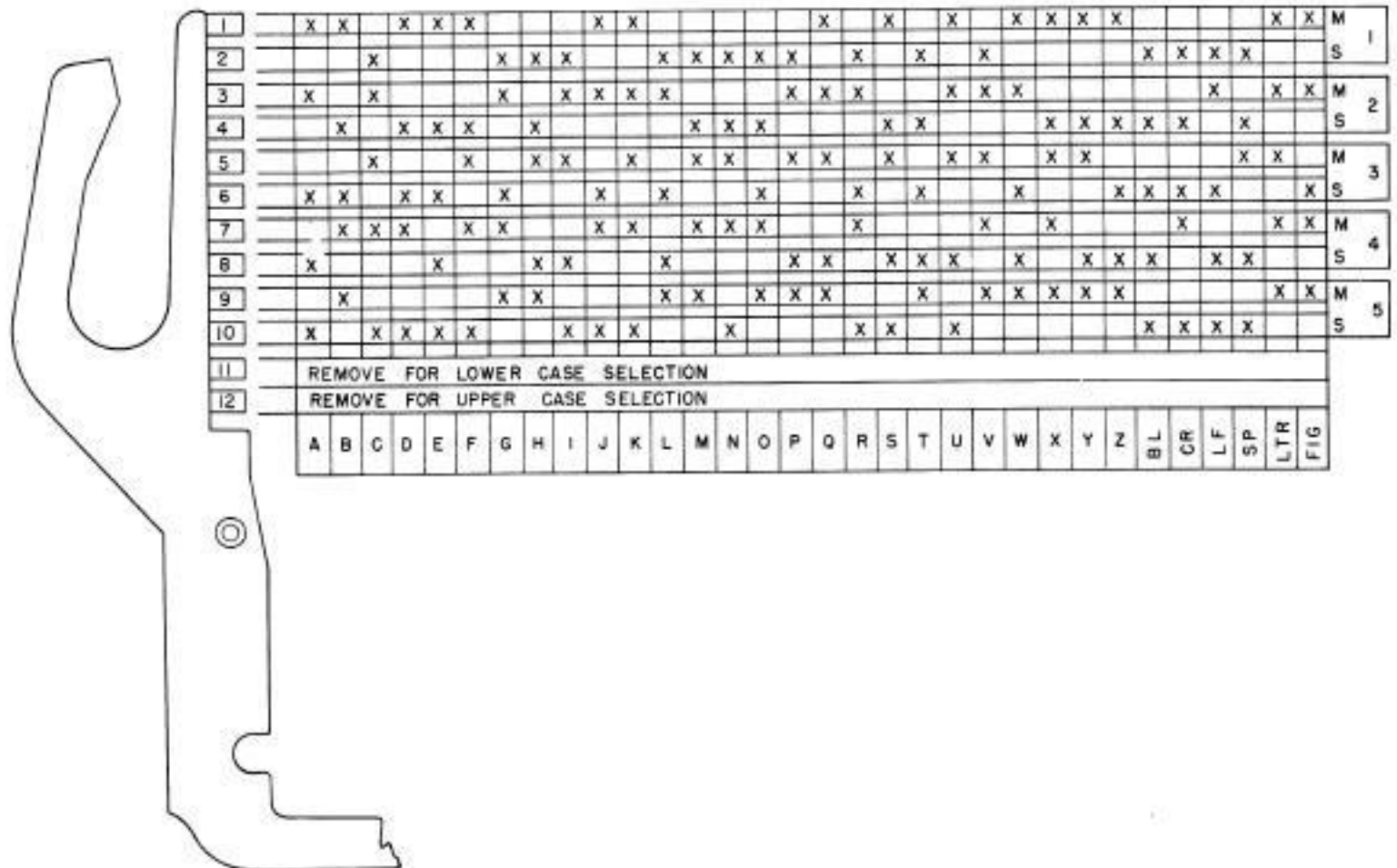
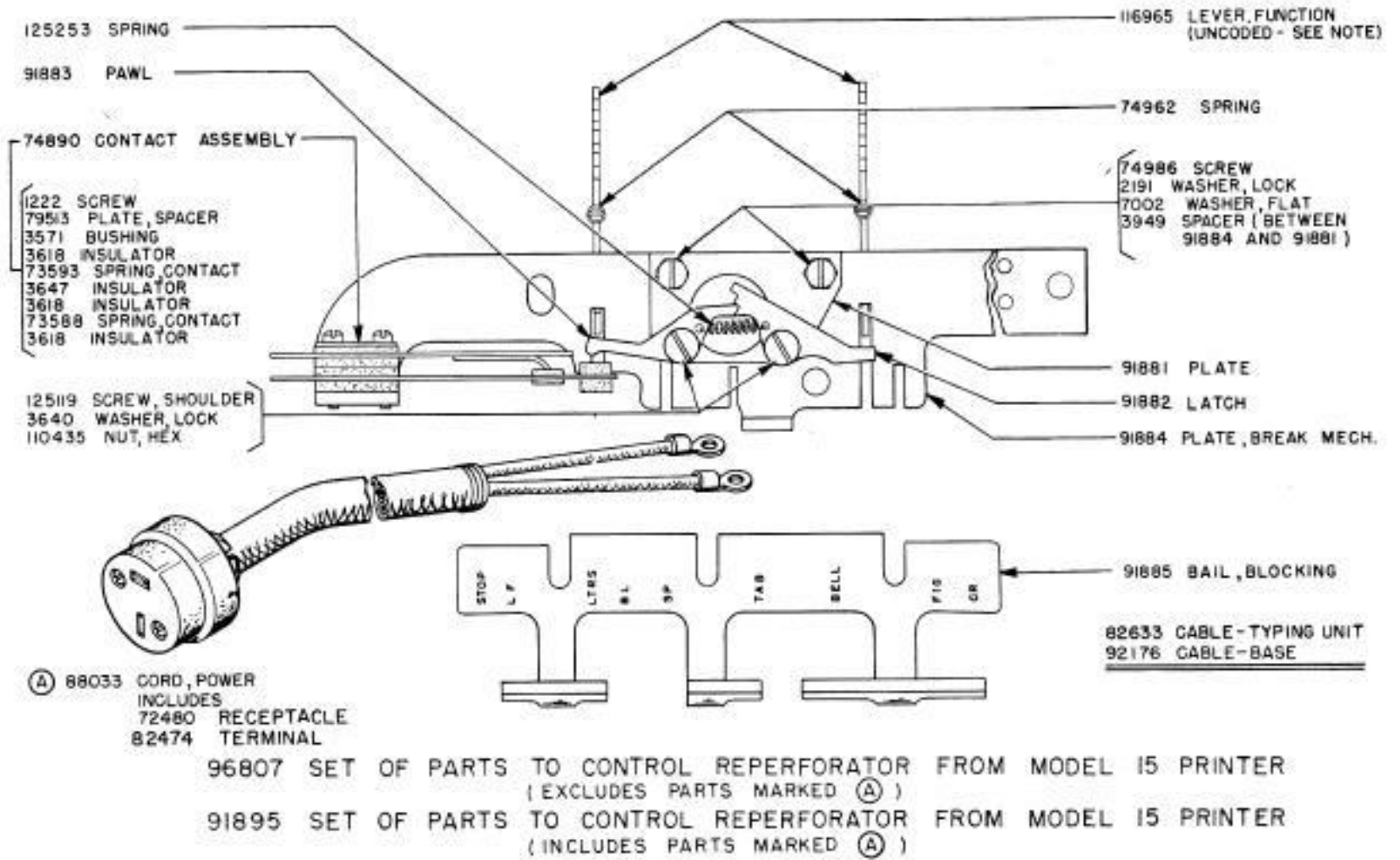

NOTE:
PLACE FUNCTION LEVER TO BE CODED ON ABOVE FIGURE NEXT TO THE CHARACTER ON WHICH OPERATION OF THE FUNCTION LEVER IS DESIRED, TAKING CARE THAT THE LUGS ARE ON THE CORRESPONDING LINES AS SHOWN IN THE FIGURE. MARK THE LUGS TO BE REMOVED AS INDICATED ON THE CHART WITH AN "X".
FOR OPERATION ON LOWER OR UPPER CASE, REMOVE LUG 11 OR 12 AS INDICATED. FOR OPERATION ON BOTH LOWER AND UPPER CASE, REMOVE LUGS 11 AND 12. THE FUNCTION LEVER SHOULD BE HELD SECURELY NEAR THE SCORE MARK, WHEN REMOVING THE LUGS, TO PREVENT DISTORTION OF THE LEVER.

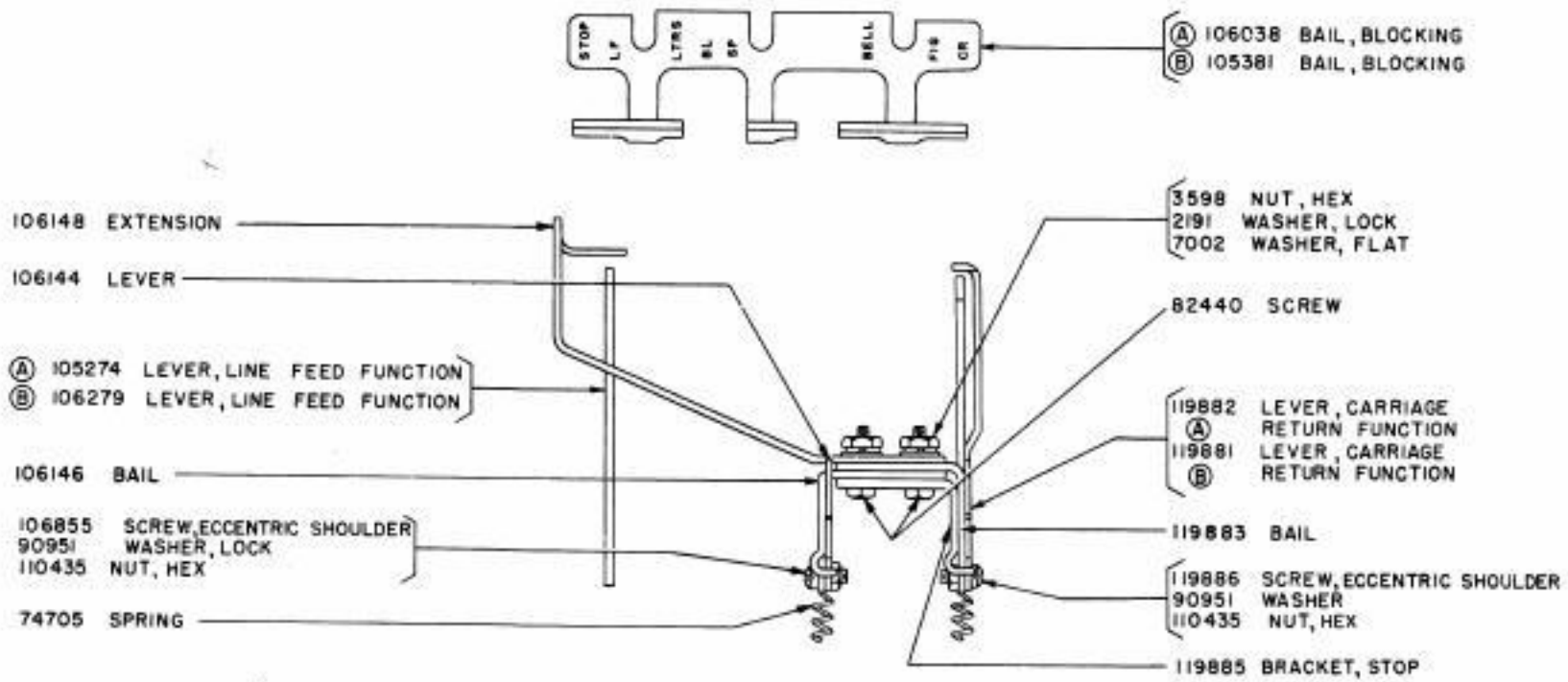

BAIL AND FUNCTION LEVER PARTS

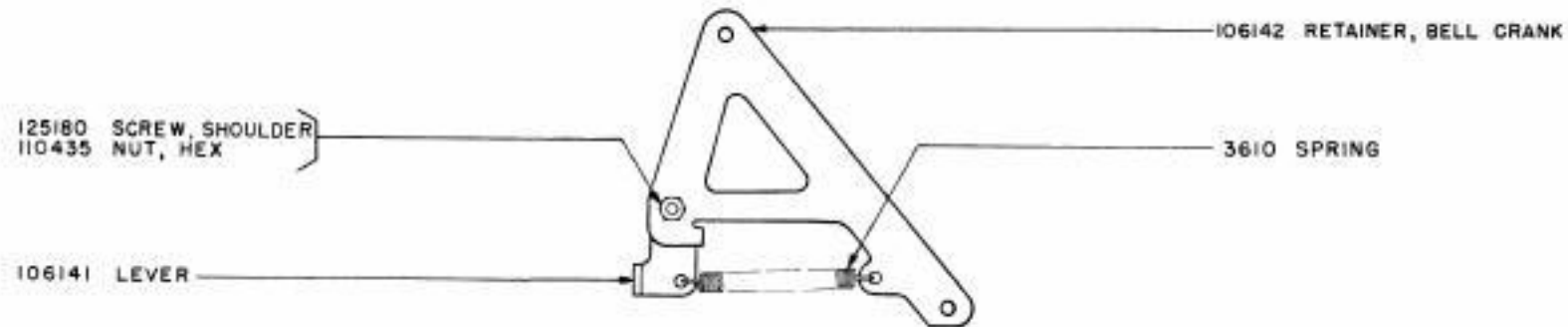

BELL CRANK RETAINER PARTS

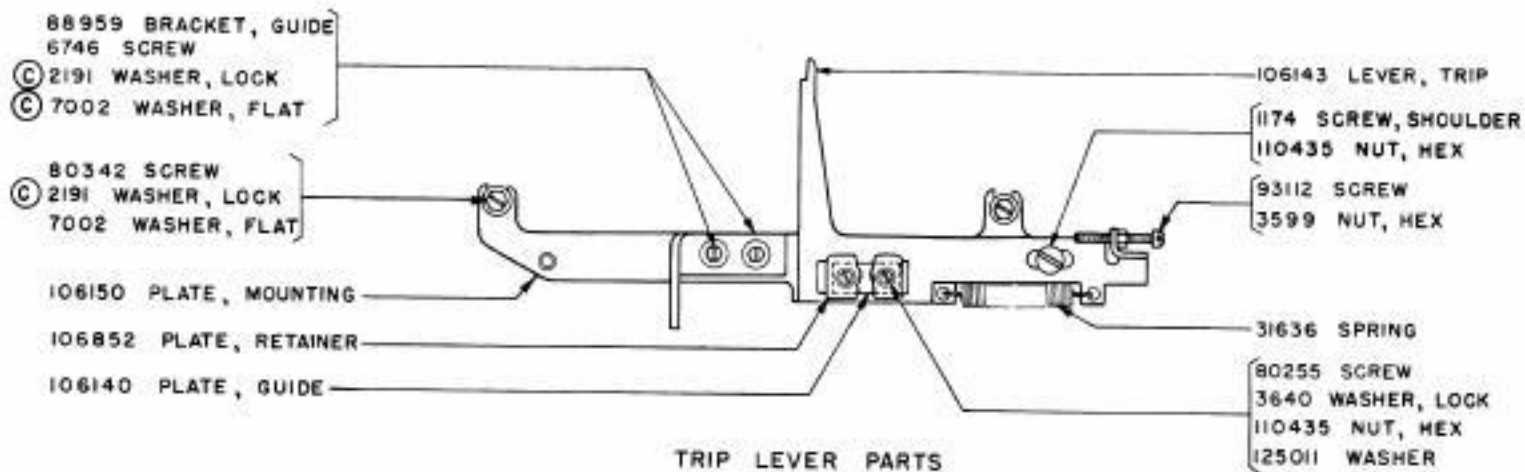

TRIP LEVER PARTS

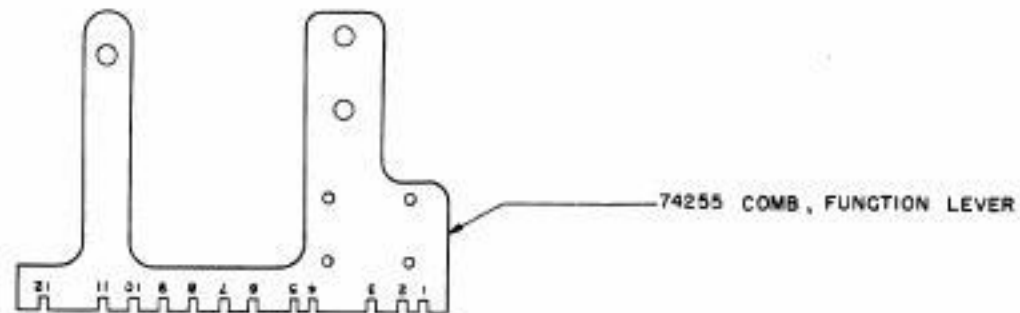

AUTOMATIC CARRIAGE RETURN AND LINE FEED PARTS

115751 SET OF PARTS FOR COMMUNICATION SERVICE
 OPERATES IN LETTERS & FIGURES POSITIONS - EXCLUDES PARTS MARKED (B) & (C)
 115752 SET OF PARTS FOR WEATHER SERVICE
 OPERATES IN LETTERS POSITION ONLY - EXCLUDES PARTS MARKED (A) & (C)

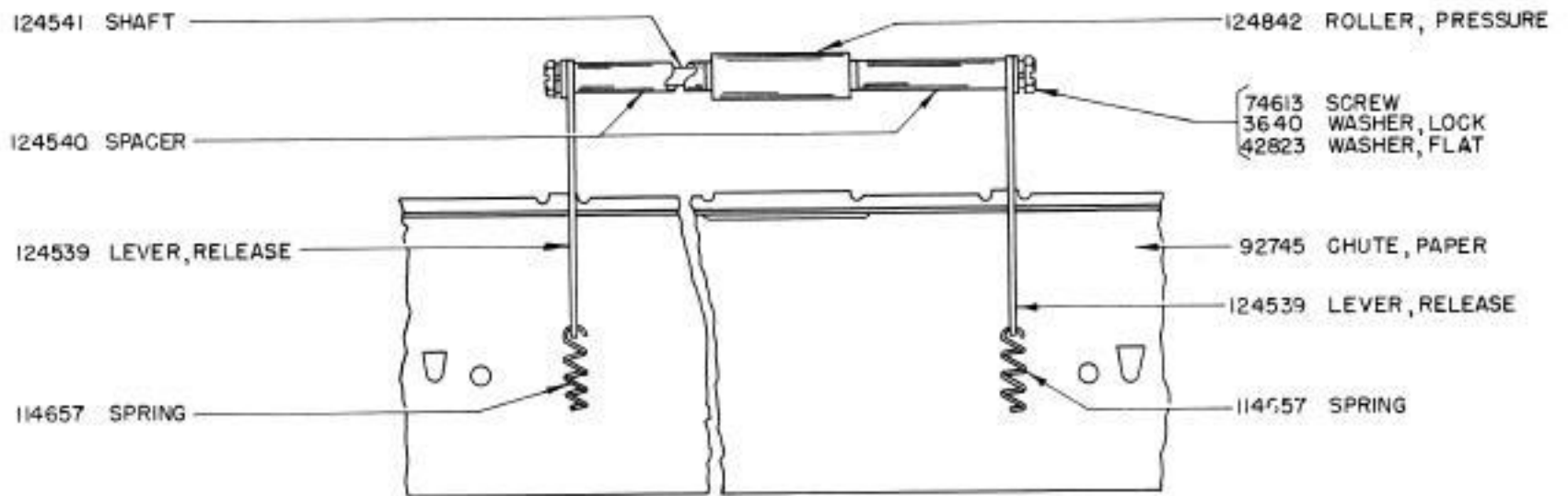

(A) 115790 SET OF PARTS TO PROVIDE A SINGLE PRESSURE ROLLER ON THE PLATEN

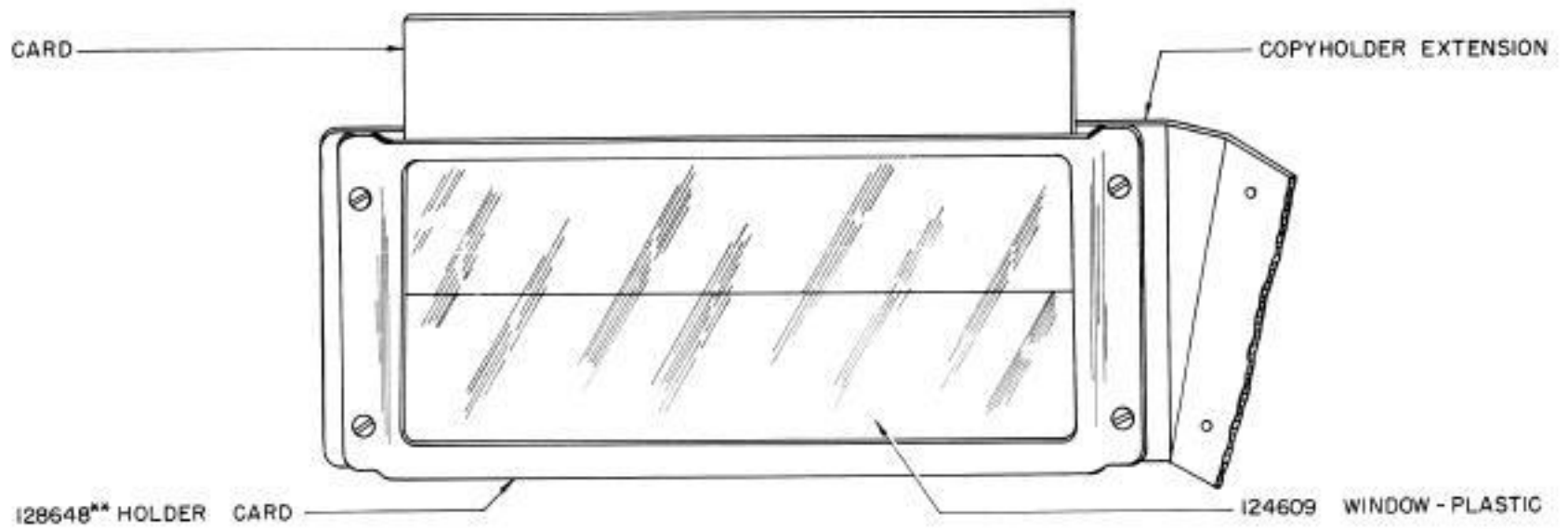

124608** SET OF PARTS FOR INSTRUCTION CARD HOLDER
(ACCOMODATES A CARD 3 1/2" WIDE BY 8 1/2" LONG)

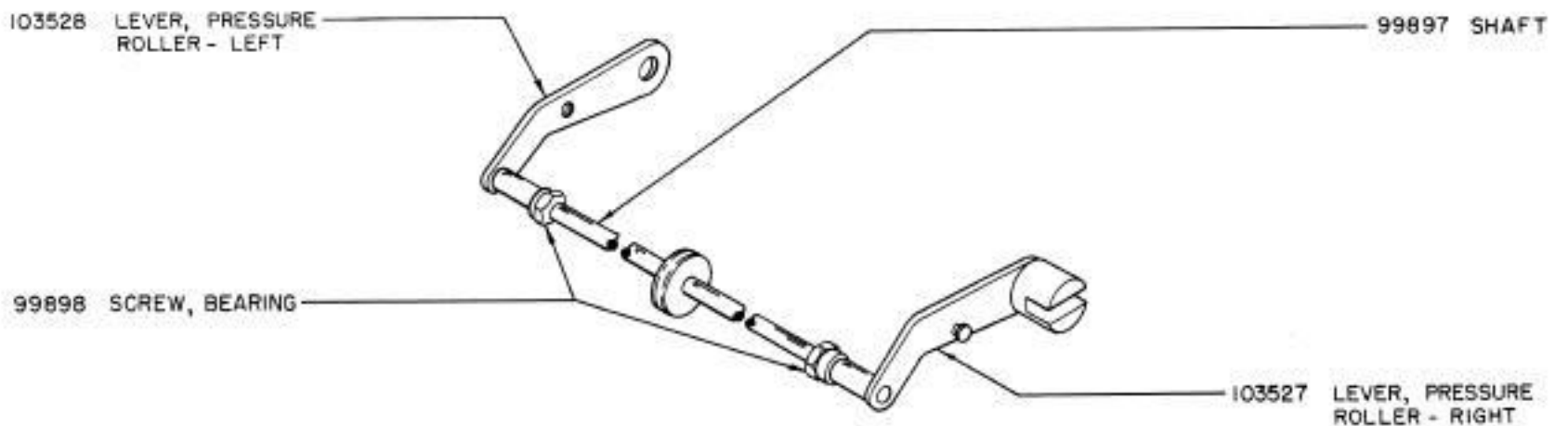

113699 PAPER GUIDE ROLLER SHAFT ASSEMBLY
(REQUIRED FOR SPROCKET FEED PRINTERS EQUIPPED WITH TWO-COLOR PRINTING)

(A) SEE SEC. IX FOR EXPLANATION
**SEE SEC. IX, PAGE 4 FOR EXPLANATION

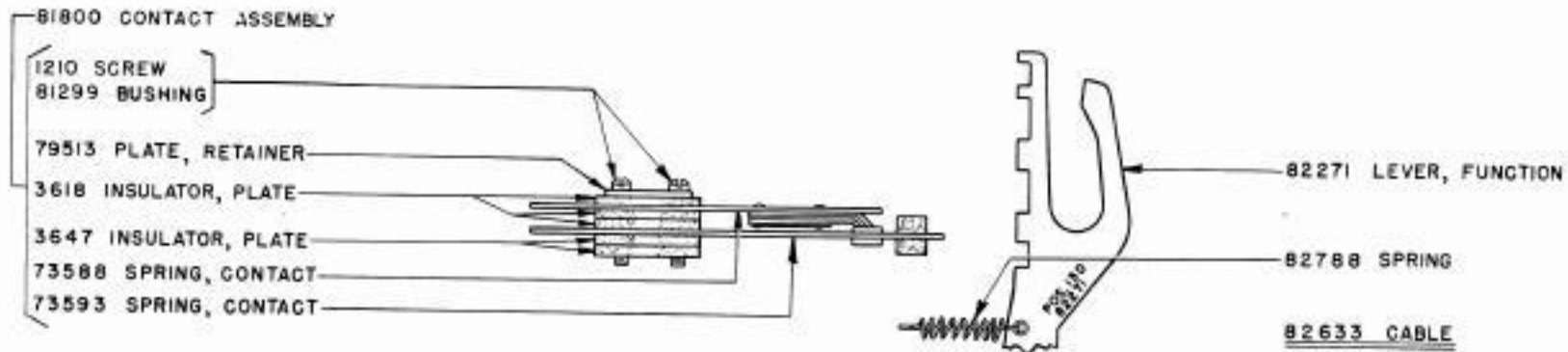

87868 SET OF PARTS FOR UPPER CASE "H" CONTACT MECHANISM

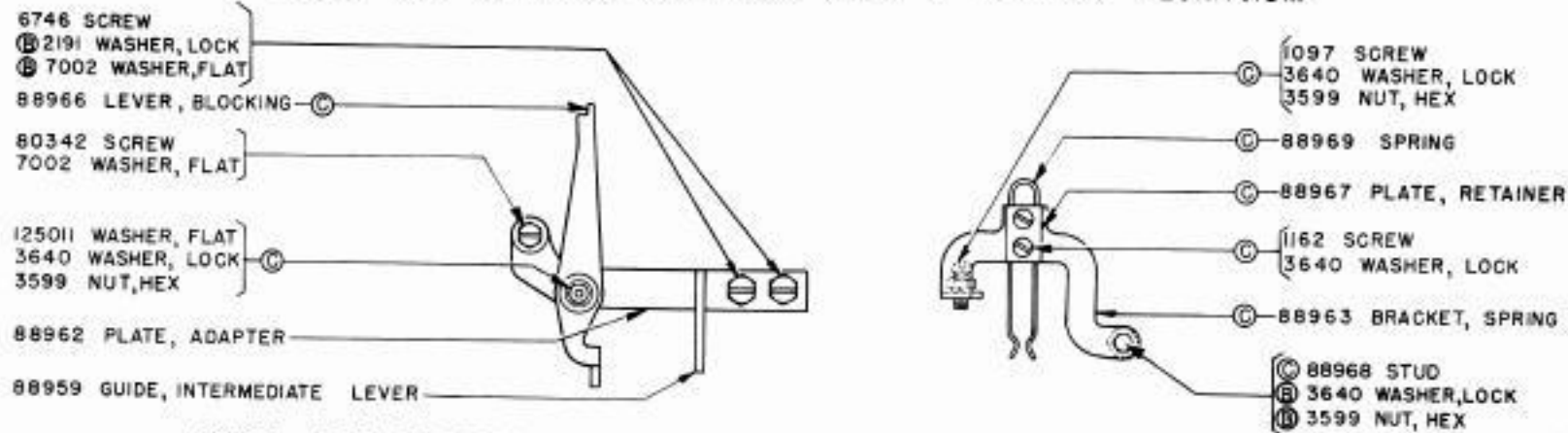

87403 SET OF PARTS TO ADAPT A MECHANICAL OR ELECTRICAL MOTOR CONTROL MECHANISM TO OPERATE ON SHIFT-BLANK-STOP (EXCLUDES PARTS MARKED (B))

106039 SET OF PARTS (SAME AS ABOVE) FOR PRINTERS EQUIPPED WITH THE AUTOMATIC CARRIAGE RETURN AND LINE FEED MECHANISM (CONSISTS OF PARTS MARKED (C))

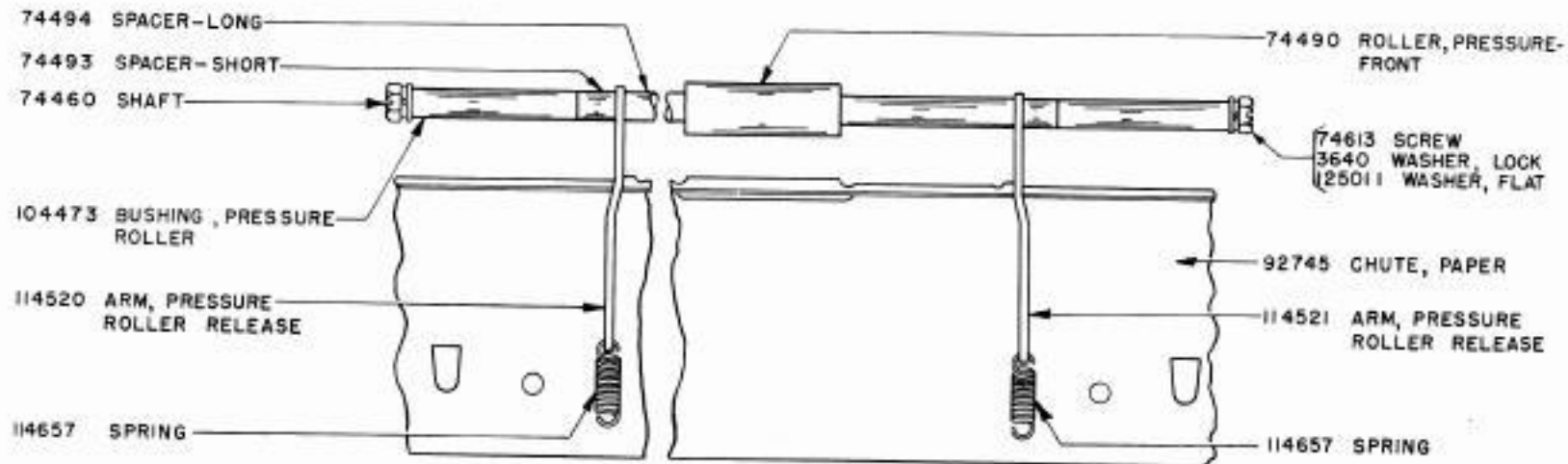

SINGLE PRESSURE ROLLER PARTS

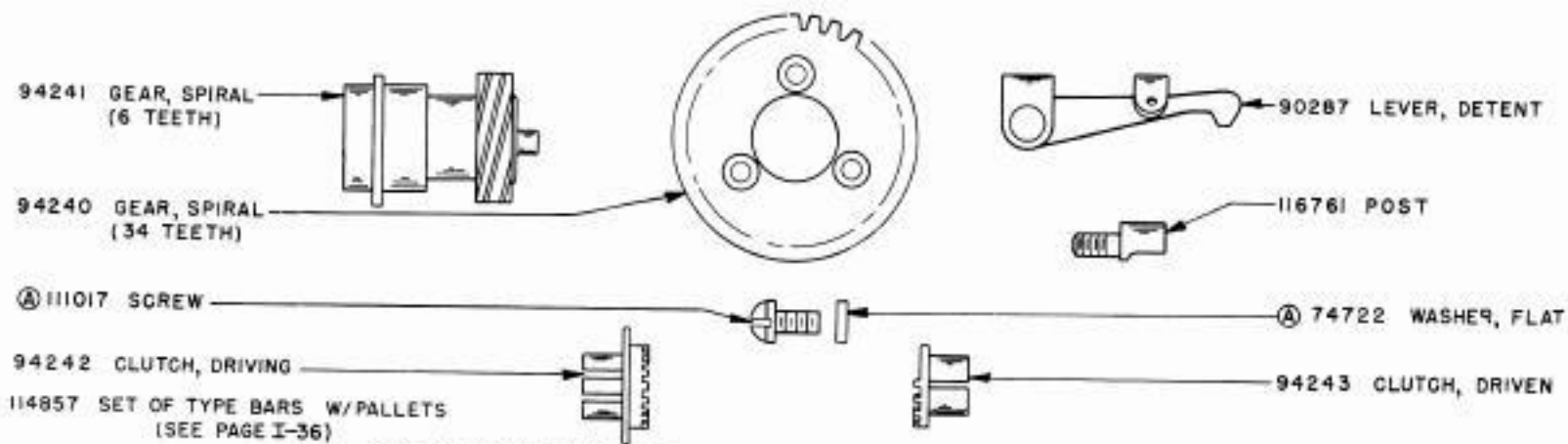

113763 SIX CHARACTERS PER INCH PARTS (HORIZONTALLY)

(A) SEE SEC. IV FOR EXPLANATION

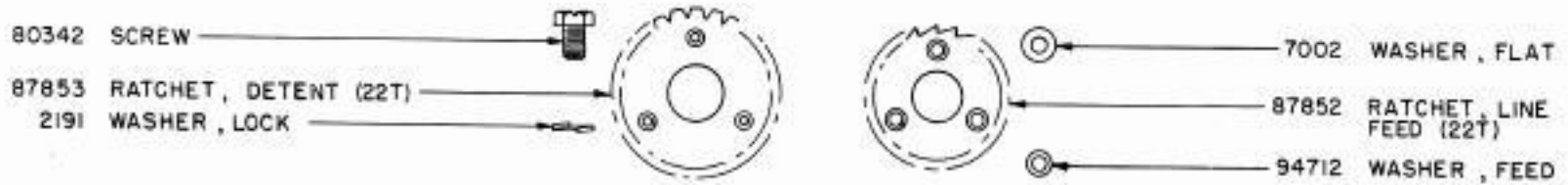

87692 SET OF PARTS FOR FEEDING FOUR LINES PER INCH

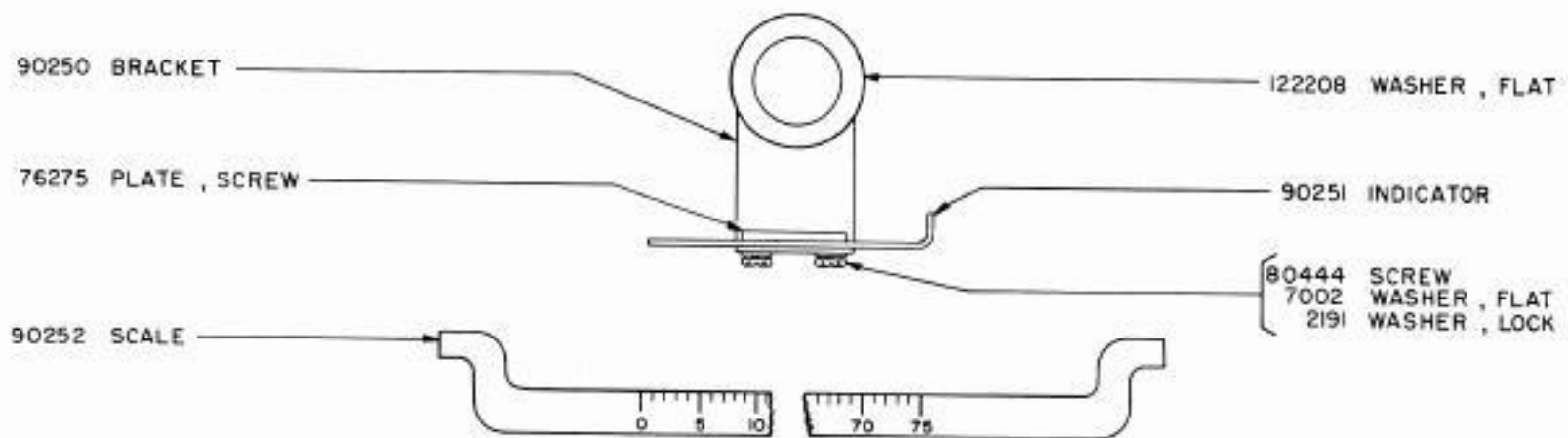

90249 SET OF PARTS FOR TABULATOR INDICATION

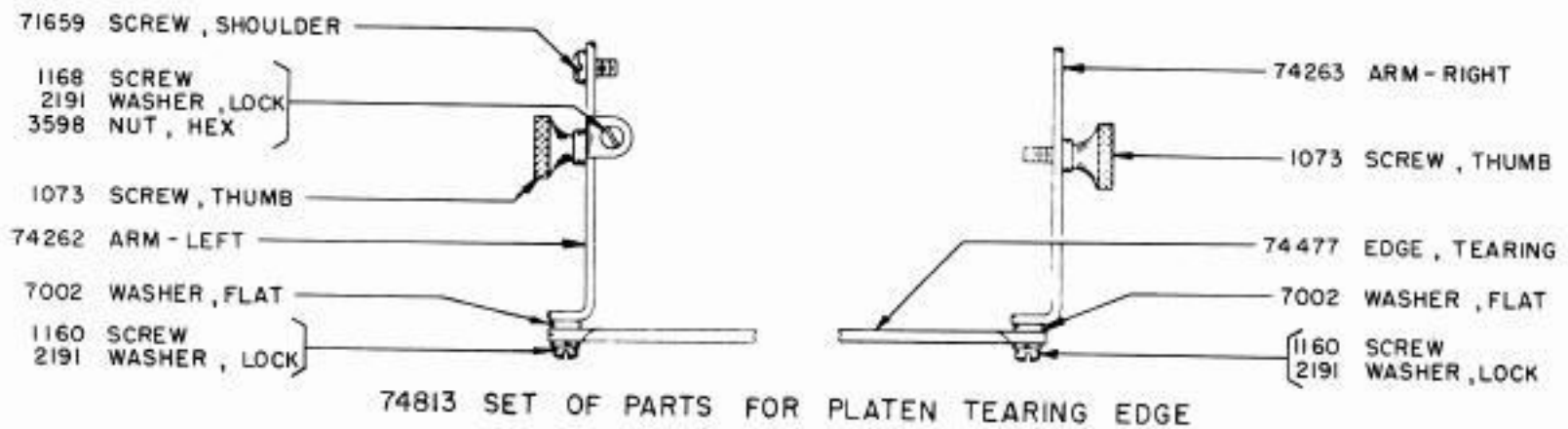

74813 SET OF PARTS FOR PLATEN TEARING EDGE

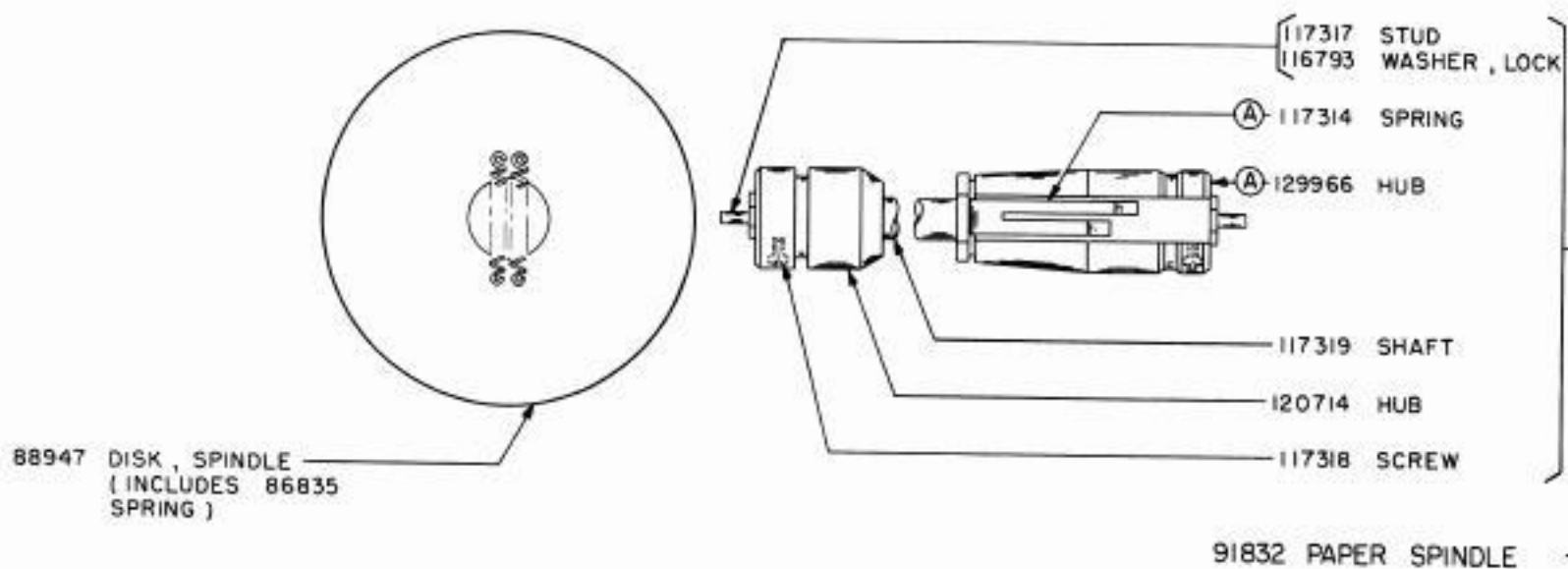

SPINDLE AND DISKS FOR USE WITH MULTI-COPY PAPER

(A) SEE SEC. IV FOR EXPLANATION

ORIGINAL

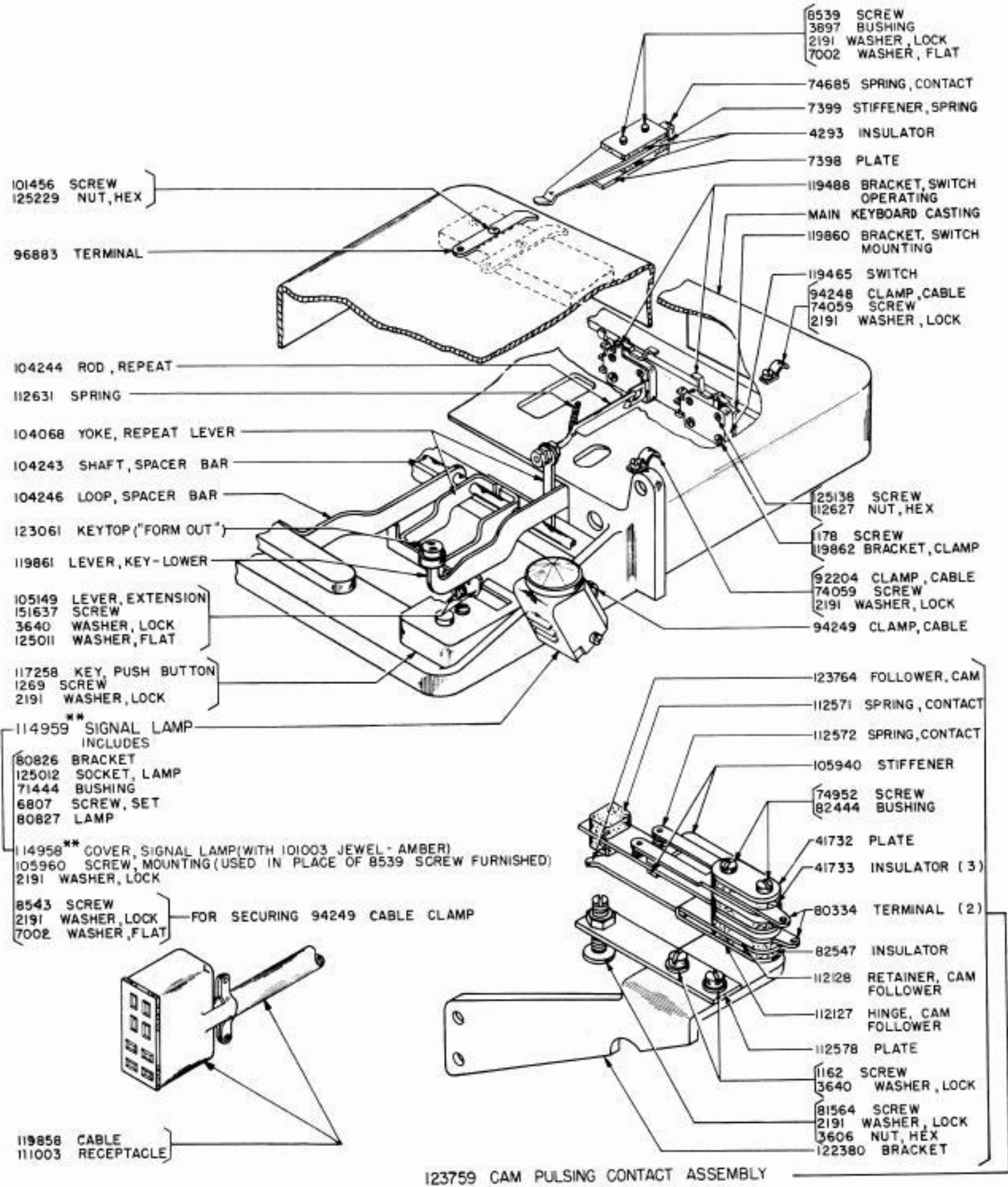

**SEE SEC. IV, PAGE 4 FOR EXPLANATION

- 123745 SET OF PARTS FOR LINE FEED COUNTING
- 123743 LINE FEED COUNTER ASSEMBLY (SHOWN ABOVE)
- 123744 ACCESSORY BOX (SHOWN ON PAGE I-59)

123756 BOX, APPARATUS
(W.E. CO. 105A)

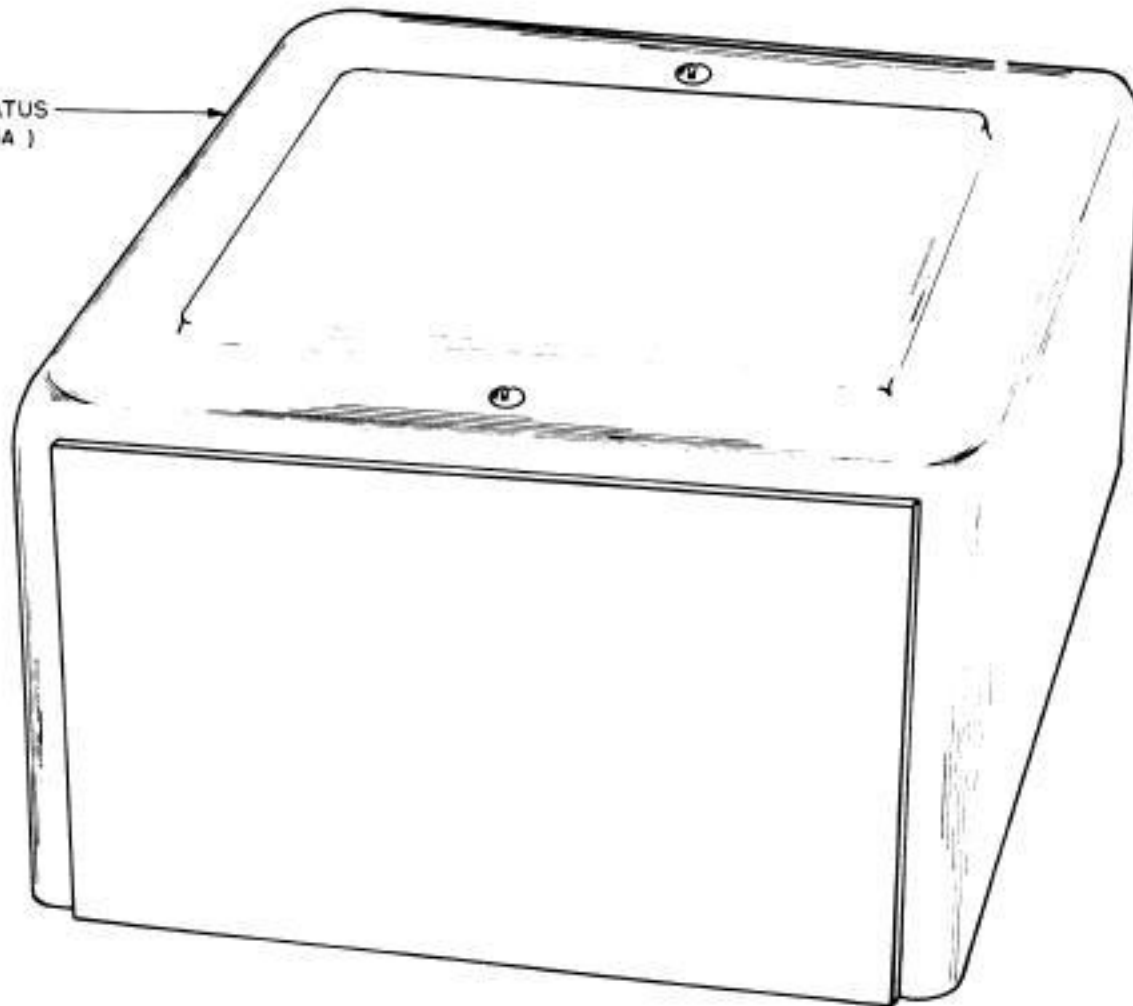

123760 SELECTOR
(W.E. CO. 206CJ)

123763 MOUNTING, APPARATUS
(W.E. CO. 5B)

125170 SCREW
3646 WASHER, LOCK

123761 BANK, CONTACT
(W.E. CO. 26A)

101470 PLUG

8543 SCREW
2191 WASHER, LOCK

93636 RESISTOR (100 OHMS)
1297 SCREW
3646 WASHER, LOCK
3438 WASHER, FLAT
83355 WASHER - FIBER

123765 CABLE (2707WD)

ENLARGED VIEW OF
CONTACT ASSEMBLY
(PART OF 123760 SELECTOR)

123758 CAPACITOR - 1 MF.

123762 MOUNTING, APPARATUS
(W.E. CO. 5A)

1026 SCREW
2191 WASHER, LOCK
7002 WASHER, FLAT

115299 STRIP, TERMINAL

1043 SCREW
2669 WASHER, LOCK

4851 TERMINAL

120122 RESISTOR (330 OHMS)

123757 BRACKET, MOUNTING

123744 ACCESSORY BOX
PART OF 123745 SET OF PARTS FOR LINE FEED COUNTING

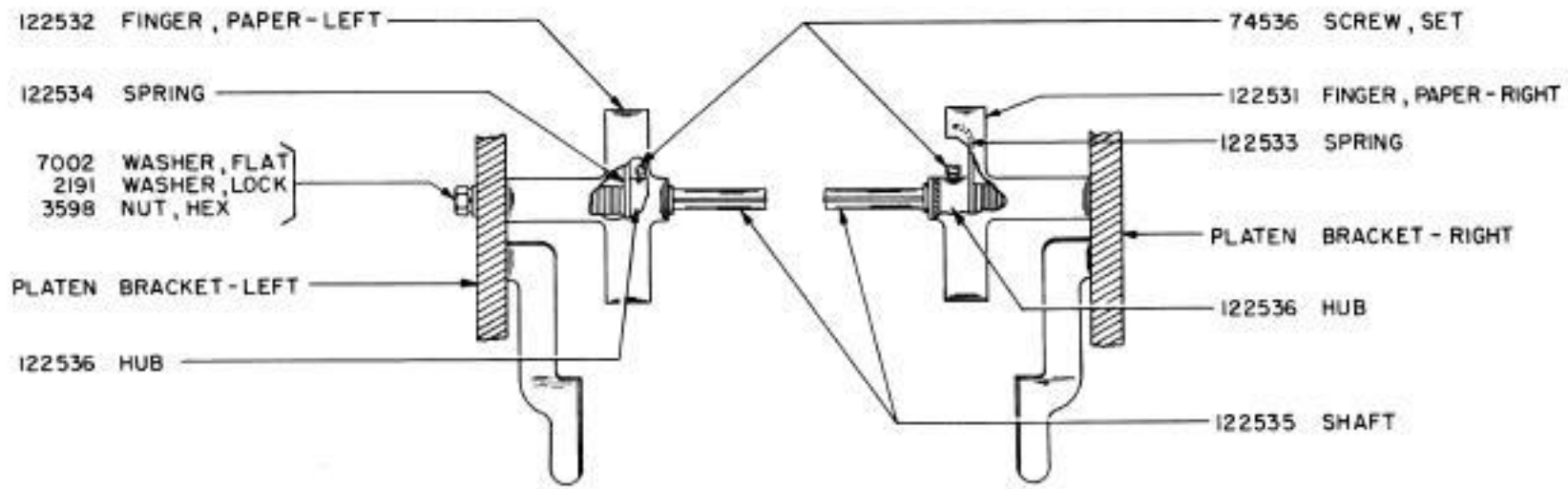

113675 SET OF PARTS FOR INDEPENDENTLY OPERATED PAPER FINGERS

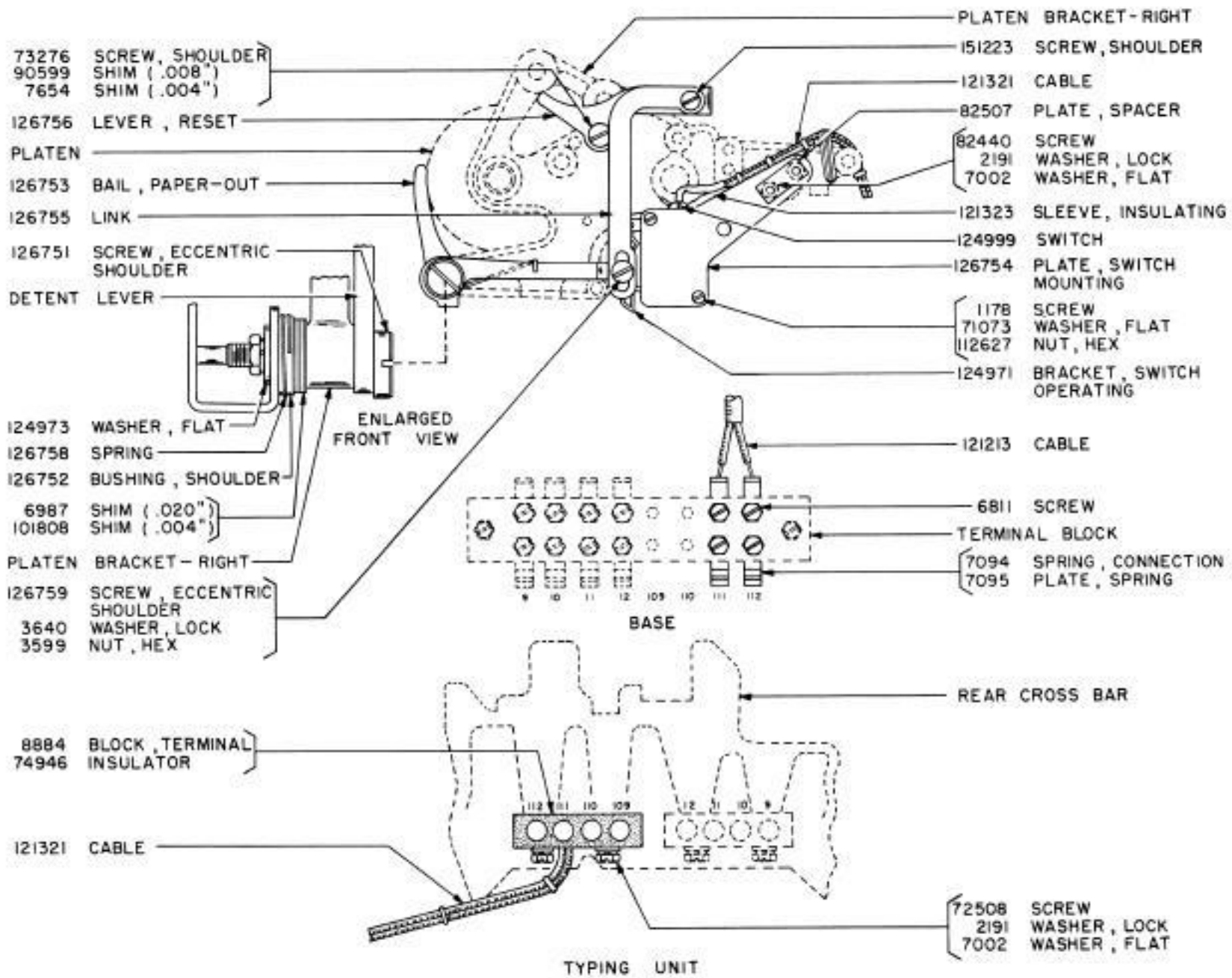

115847 SET OF PARTS TO PROVIDE END-OF-LAST-FORM INDICATING MECHANISM (MOUNTED ON THE TYPING UNIT)

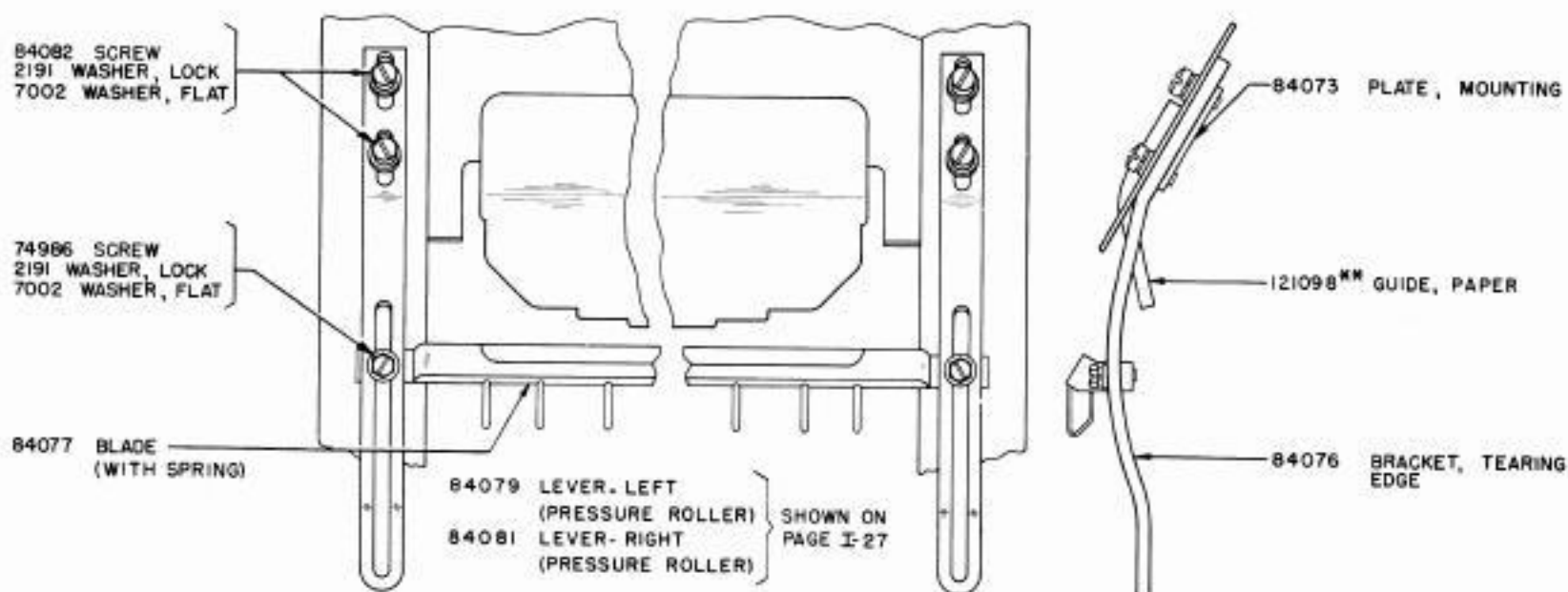

115769** SET OF PARTS TO PROVIDE SPROCKET FEED TEARING EDGE
(MOUNTED ON THE COVER)

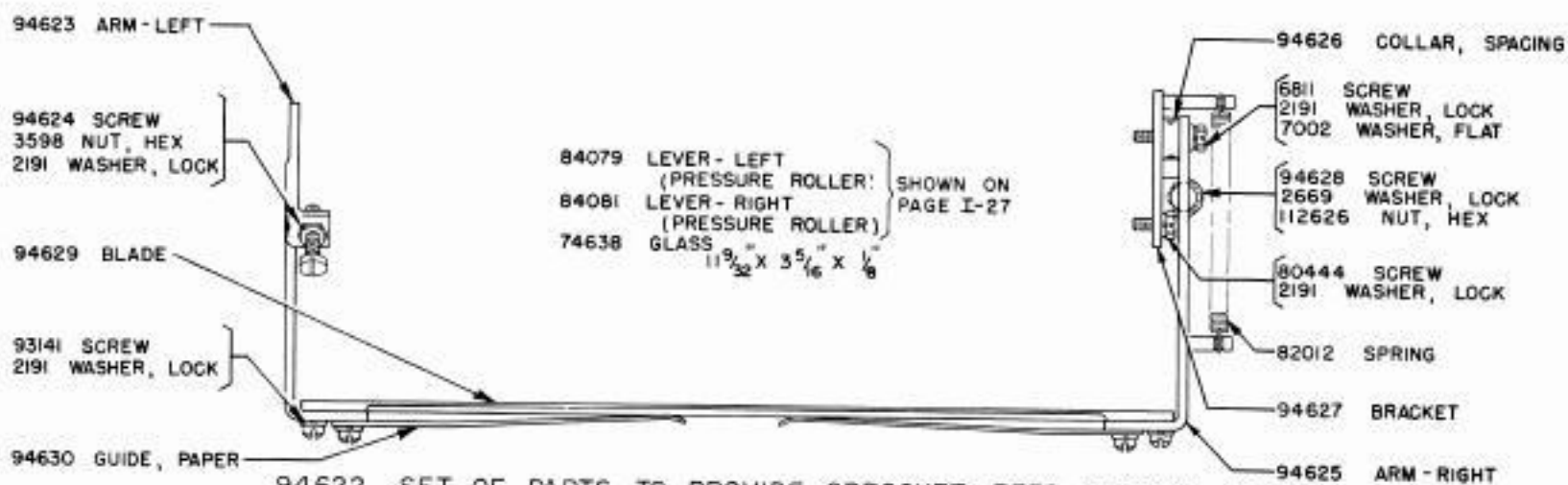

94622 SET OF PARTS TO PROVIDE SPROCKET FEED TEARING EDGE
(MOUNTING ON THE TYPING UNIT)

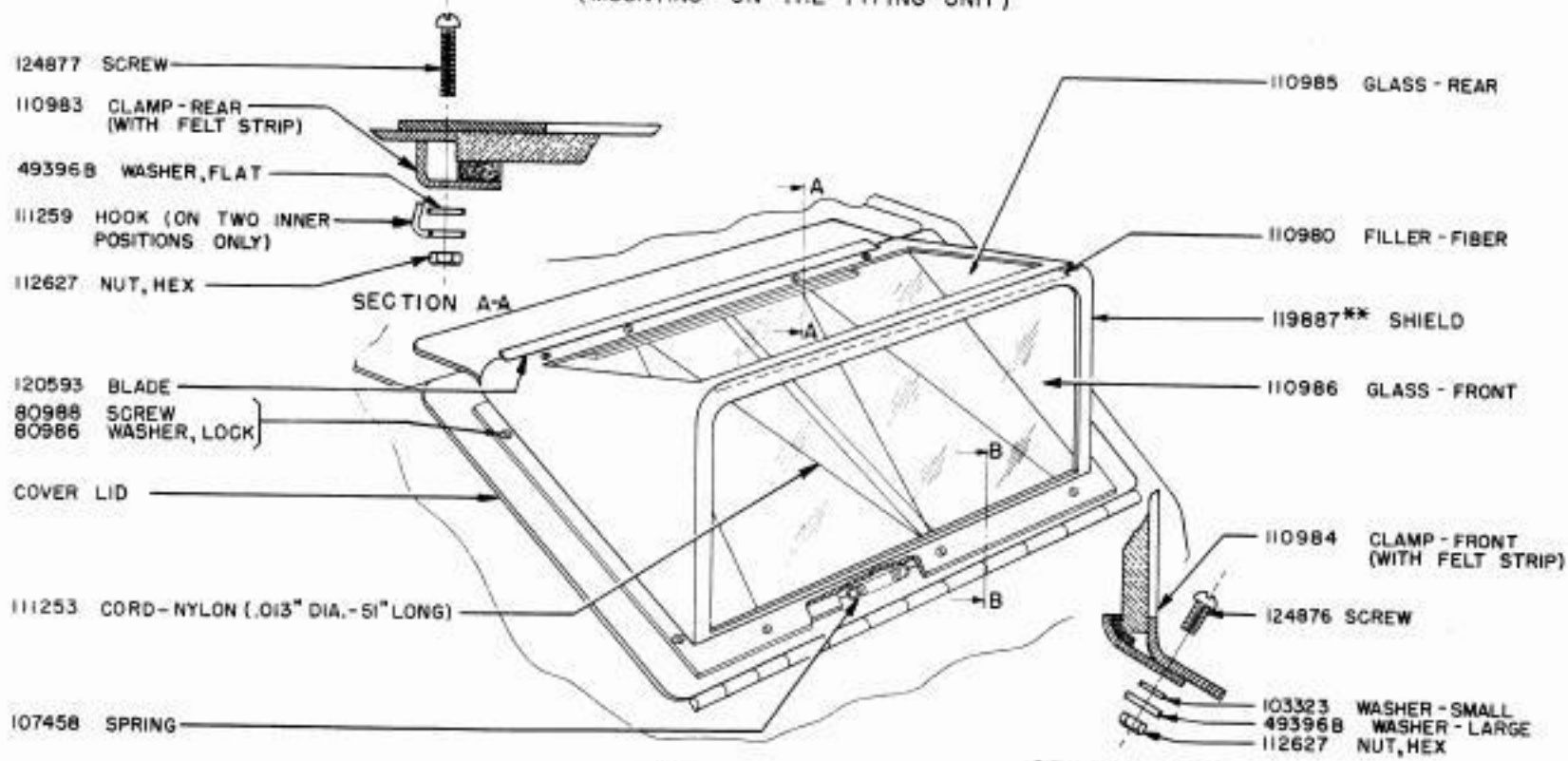

115740** GLARE SHIELD ASSEMBLY

**SEE SEC. IX, PAGE 4 FOR EXPLANATION

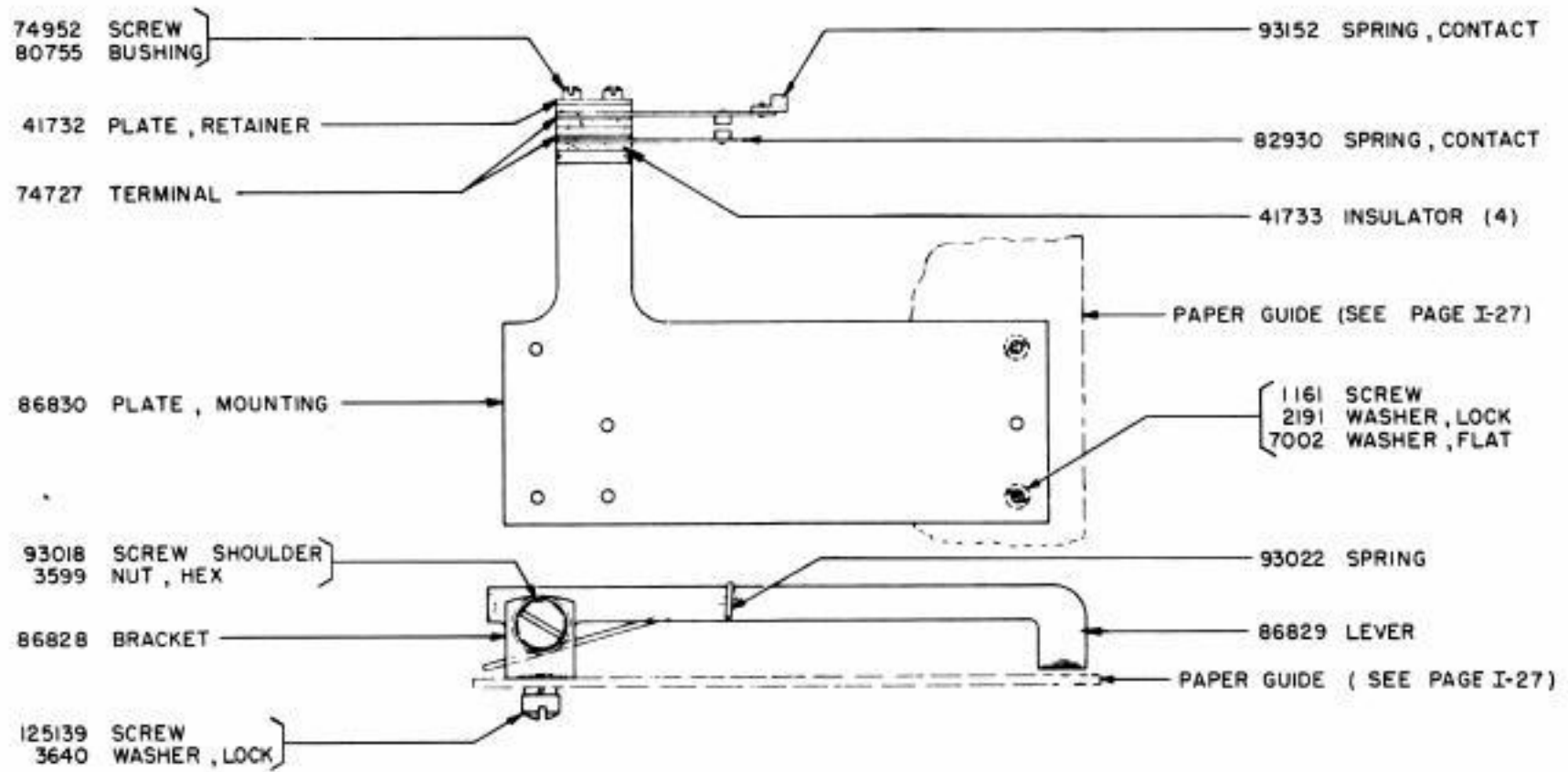

95201 SET OF PARTS TO PROVIDE END-OF-LAST-FORM INDICATING MECHANISM
(MOUNTED ON THE COVER)

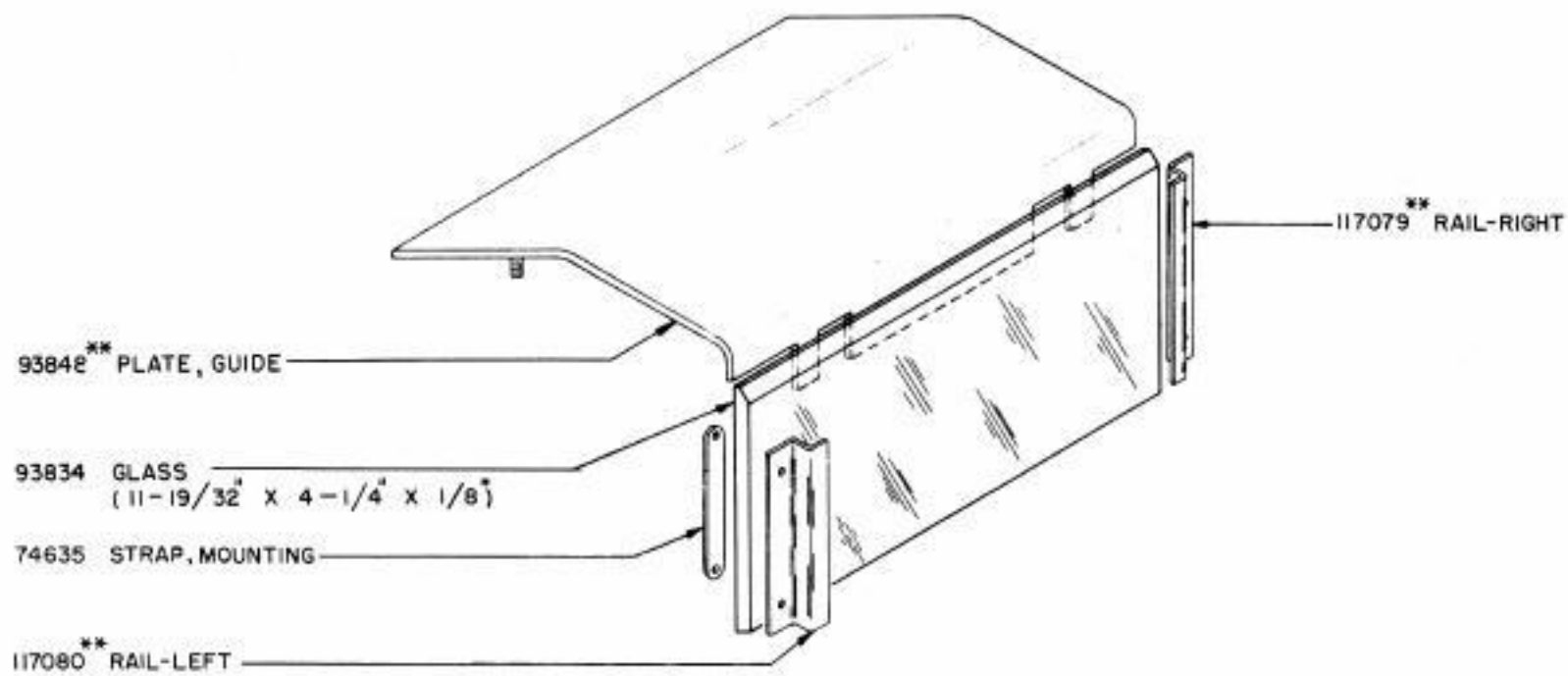

113790** PAPER GUIDE PLATE AND COVER GLASS TO PROVIDE TEAR-OFF
EDGE FOR SHORT FORMS

** SEE SEC. IV, PAGE 4 FOR EXPLANATION

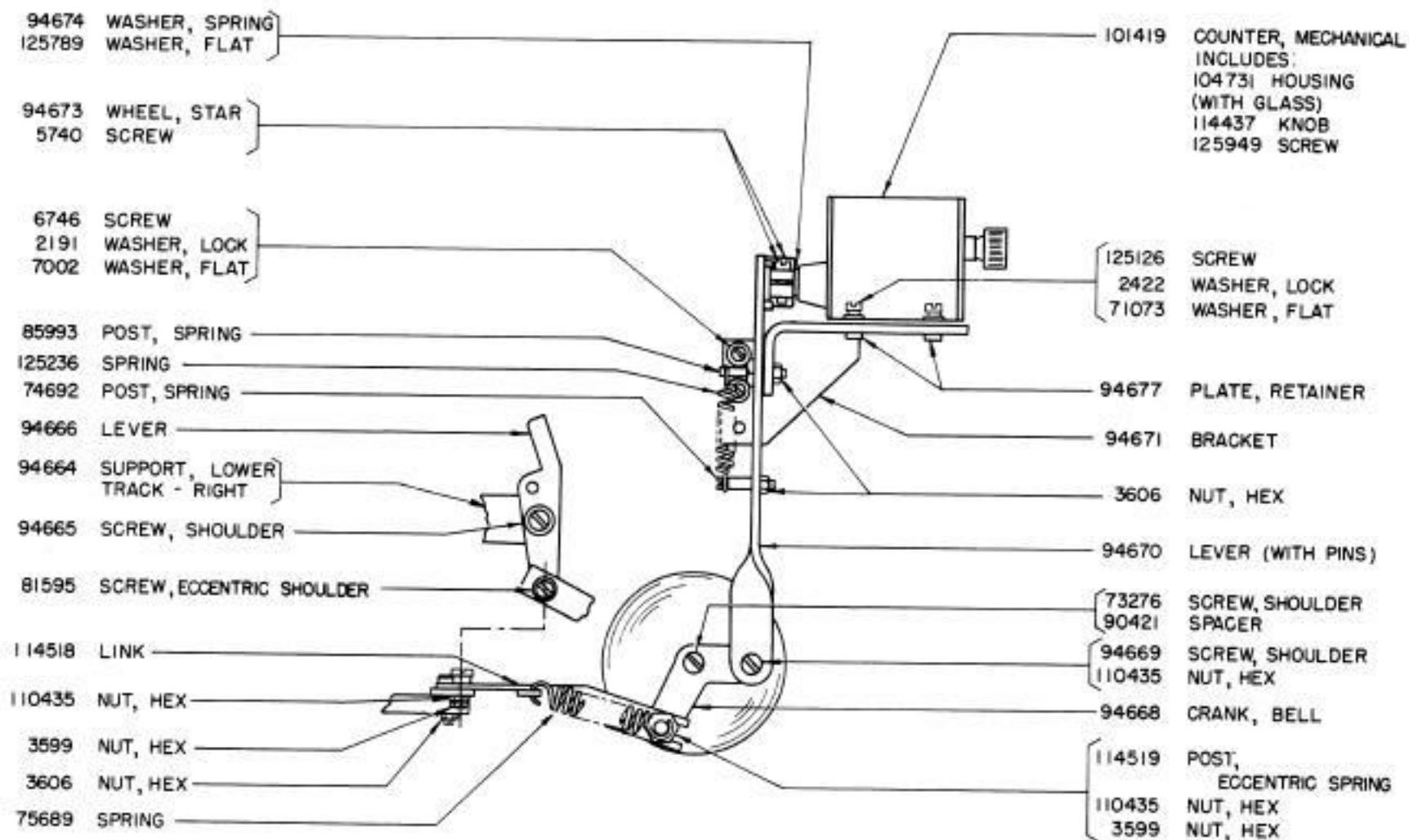

94663 SET OF PARTS FOR MECHANICAL WORD COUNTER

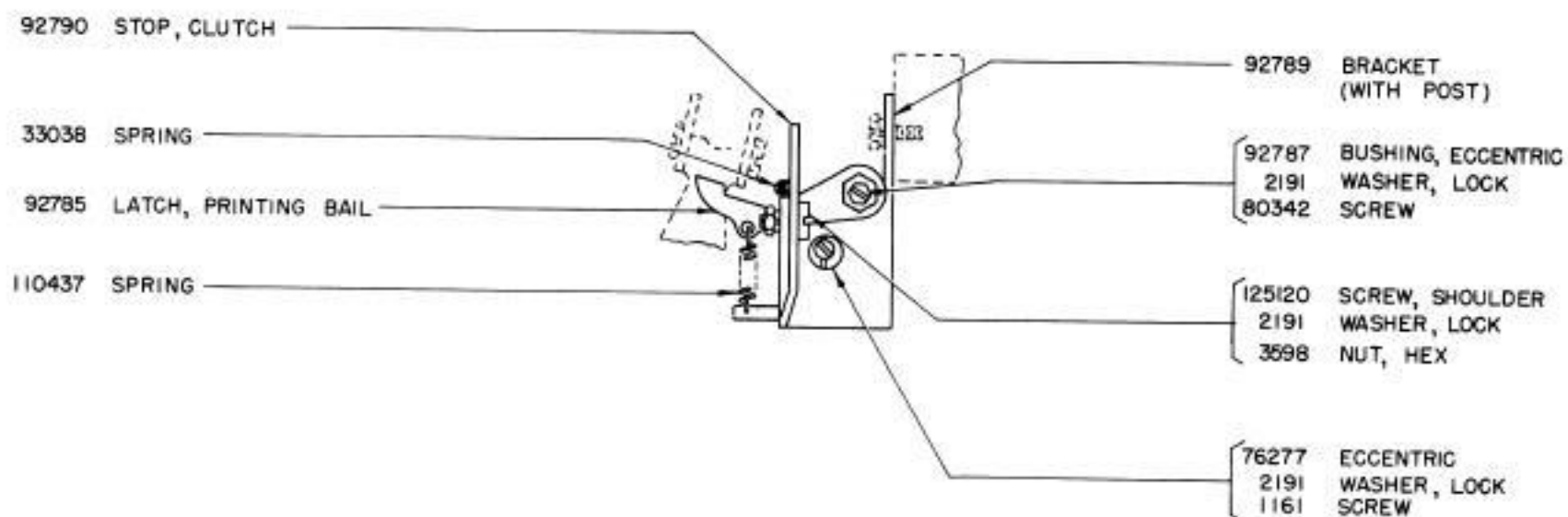

92784 SET OF PARTS TO PROVIDE END-OF-LINE PRINTING AND SPACING CUTOUT MECHANISM

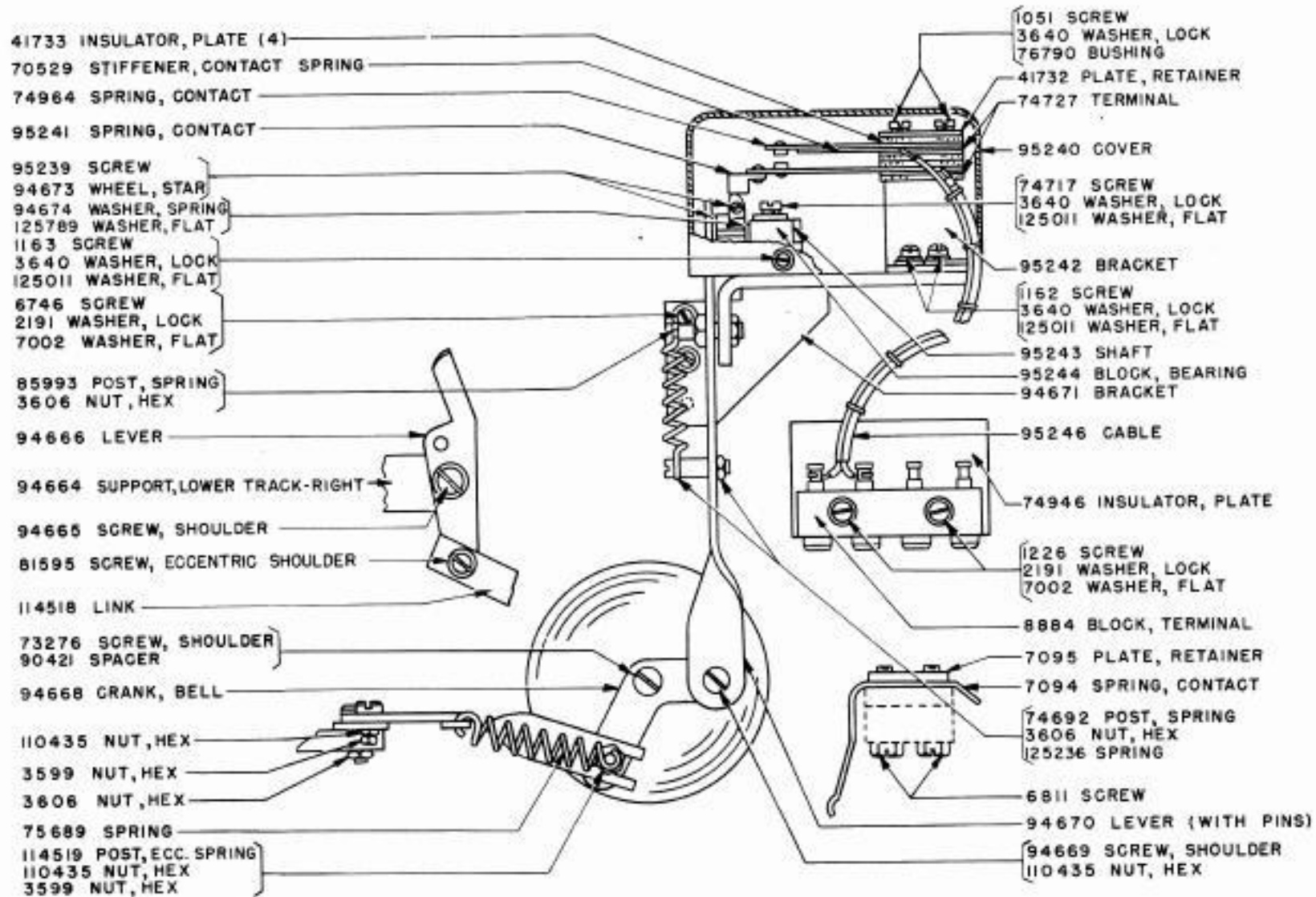

PARTS FOR ELECTRICAL COUNTER

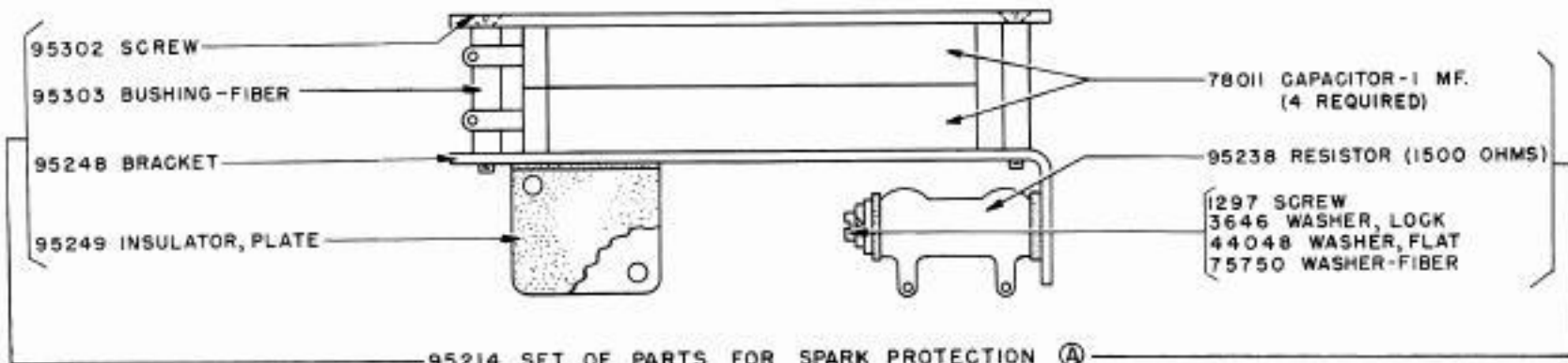

95214 SET OF PARTS FOR SPARK PROTECTION (A)

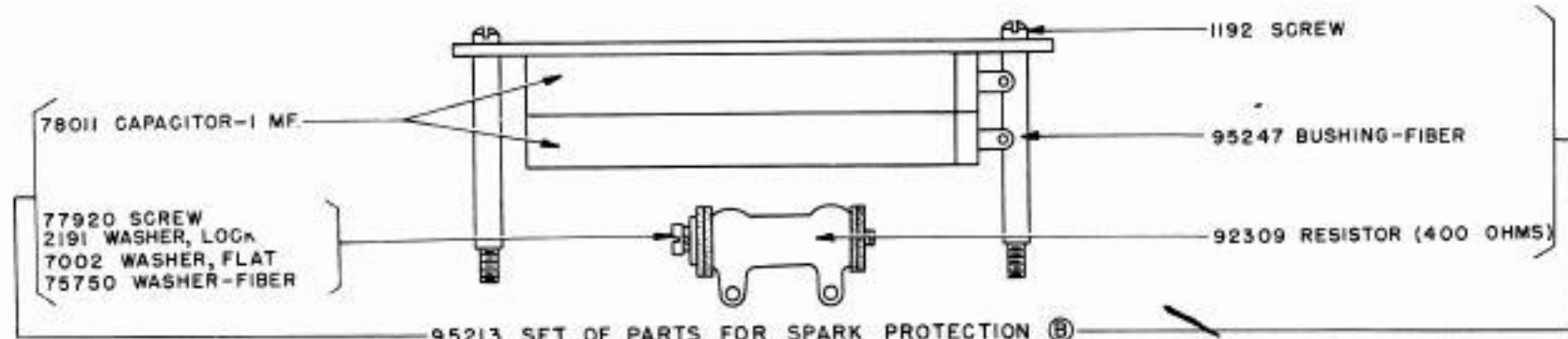

95213 SET OF PARTS FOR SPARK PROTECTION (B)

95216 SET OF PARTS TO PROVIDE ELECTRICAL WORD AND OPERATIONS COUNTER FOR USE WITH A.C. (EXCLUDES PARTS MARKED (A))

95217 SET OF PARTS TO PROVIDE ELECTRICAL WORD AND OPERATIONS COUNTER FOR USE WITH D.C. (EXCLUDES PARTS MARKED (B))

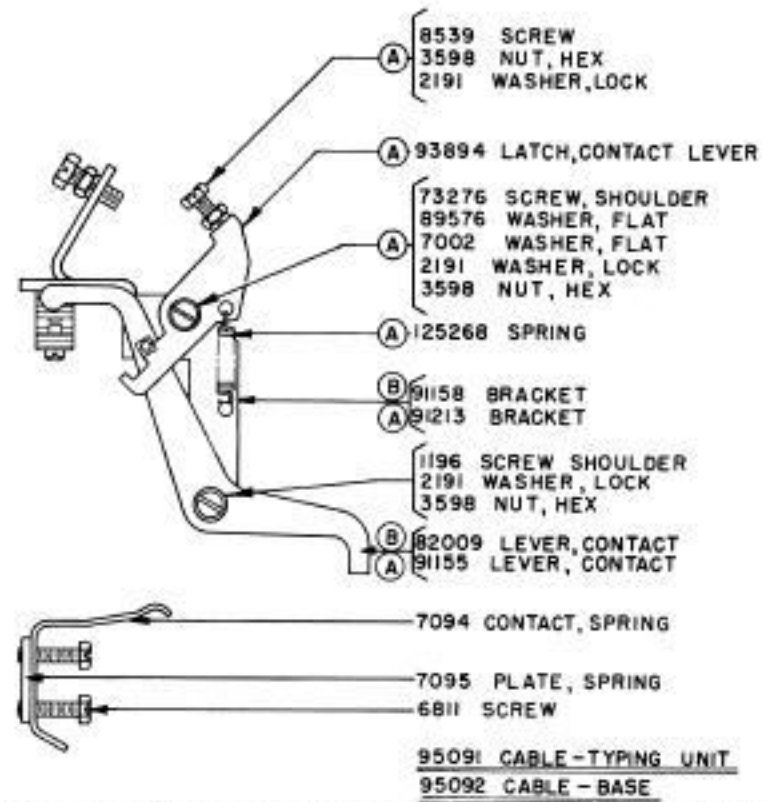
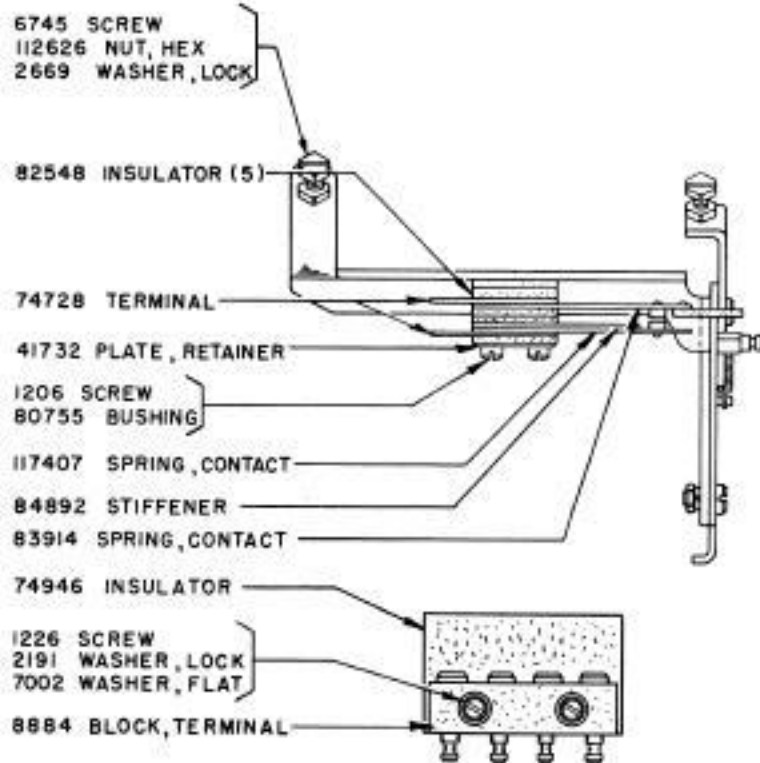

95088 SET OF PARTS FOR REMOTE SIGNAL BELL CONTACTS (WITHOUT LATCH) EXCLUDES PARTS MARKED (A)
 91159 SET OF PARTS FOR REMOTE SIGNAL BELL CONTACTS (WITH LATCH) EXCLUDES PARTS MARKED (B)

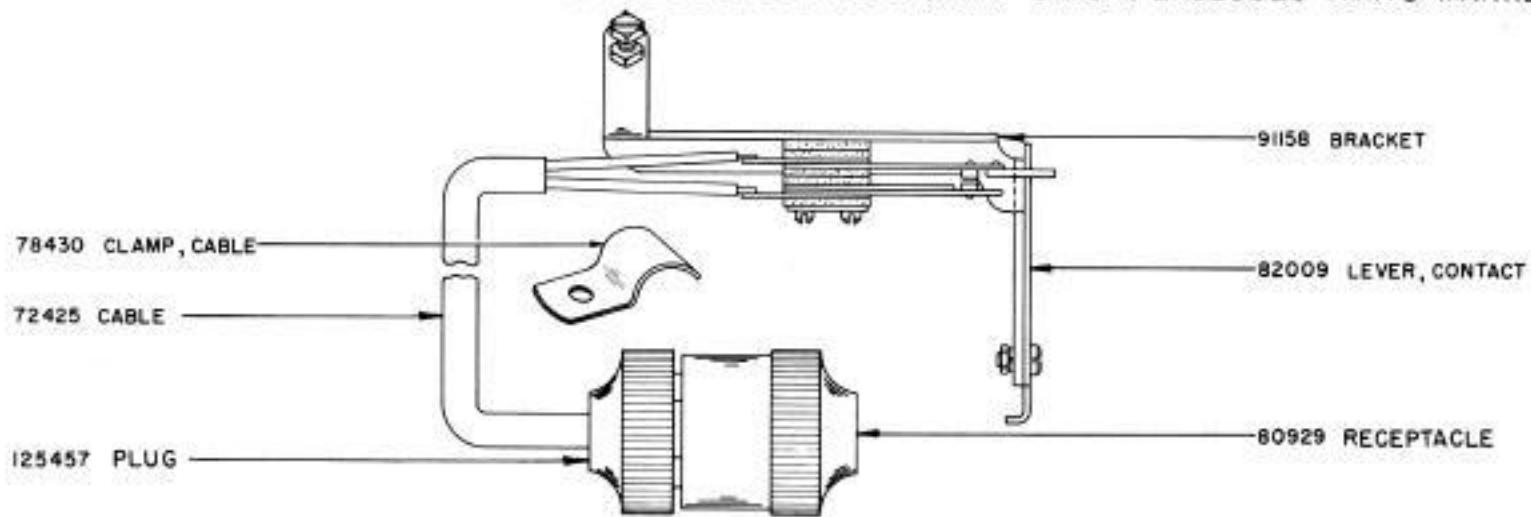

80956 SET OF PARTS FOR REMOTE SIGNAL BELL CONTACTS
 (PARTS SHOWN BUT NOT LISTED SAME AS ABOVE)

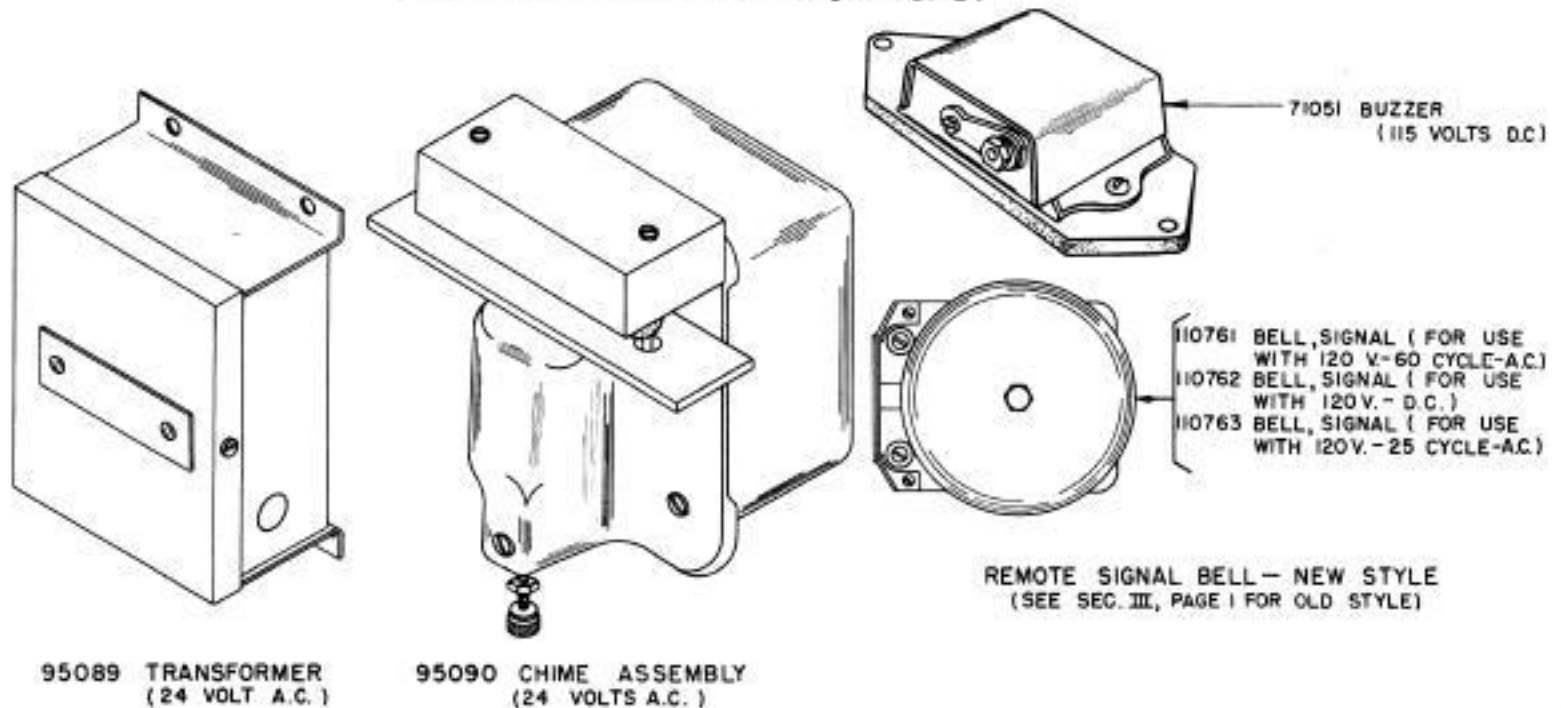

REMOTE SIGNAL BELL - NEW STYLE
 (SEE SEC. III, PAGE 1 FOR OLD STYLE)

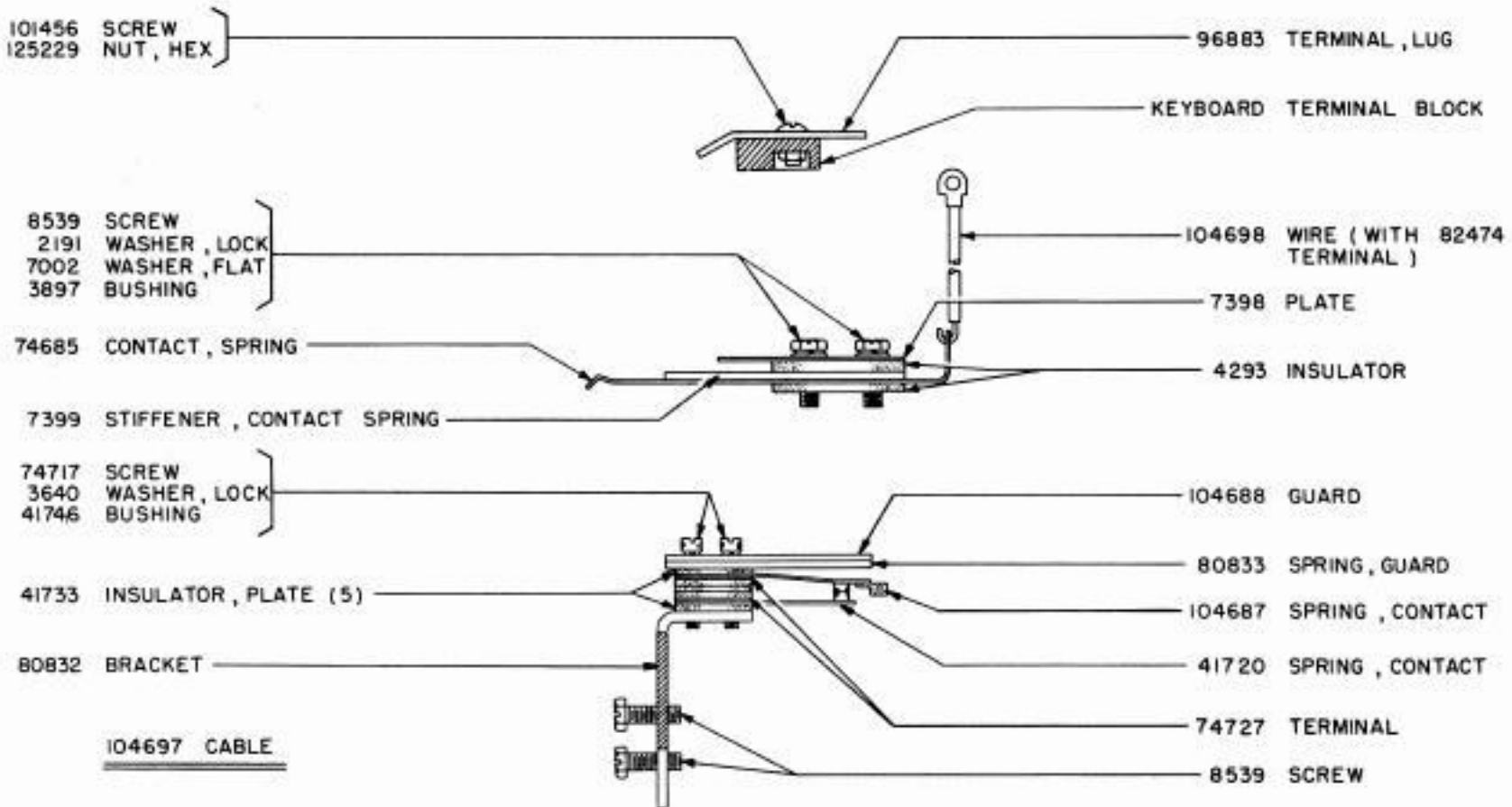

104666 SET OF PARTS FOR CAM OPERATED CONTACTS

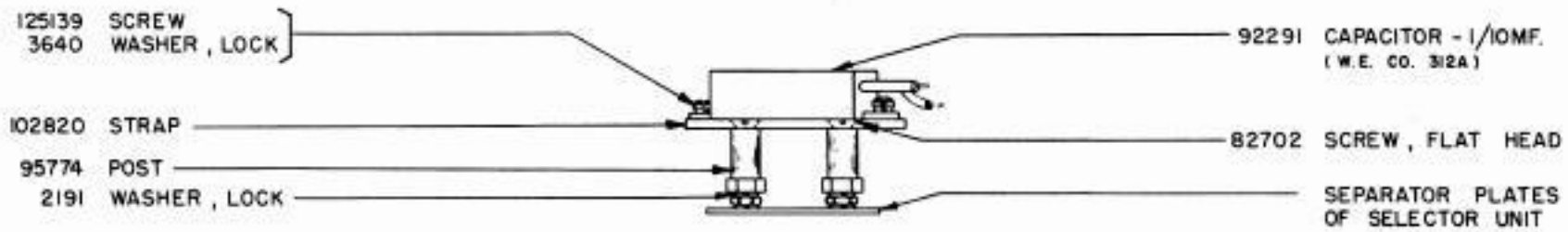

102821 SET OF PARTS TO PROVIDE 1/10MF CAPACITOR ACROSS UPPER CASE "H" MOTOR CONTROL CONTACTS



91507 SET OF PARTS FOR TRIPLE LINE FEED FUNCTION

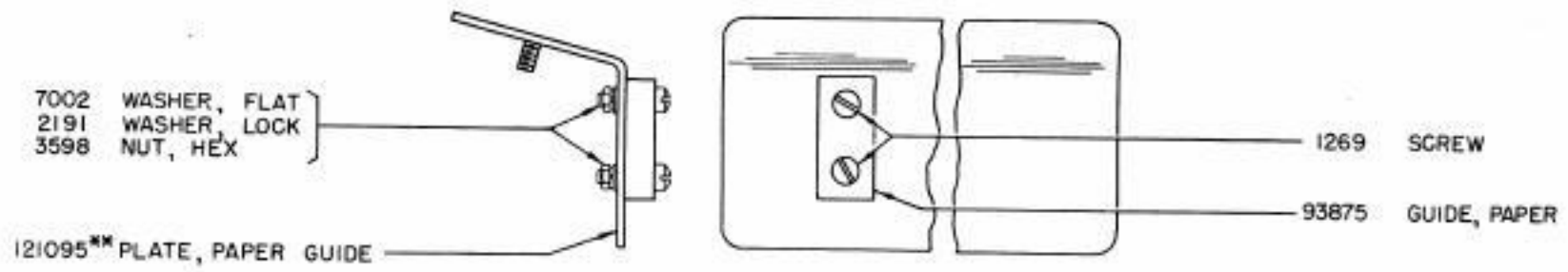

121096** PAPER GUIDE PLATE ASSEMBLY
TO FACILITATE HANDLING OF INDIVIDUAL FORMS OR MULTICOPY 8 1/2" WIDE
WITHOUT LIFTING THE TOP HINGED SECTION OF THE COVER

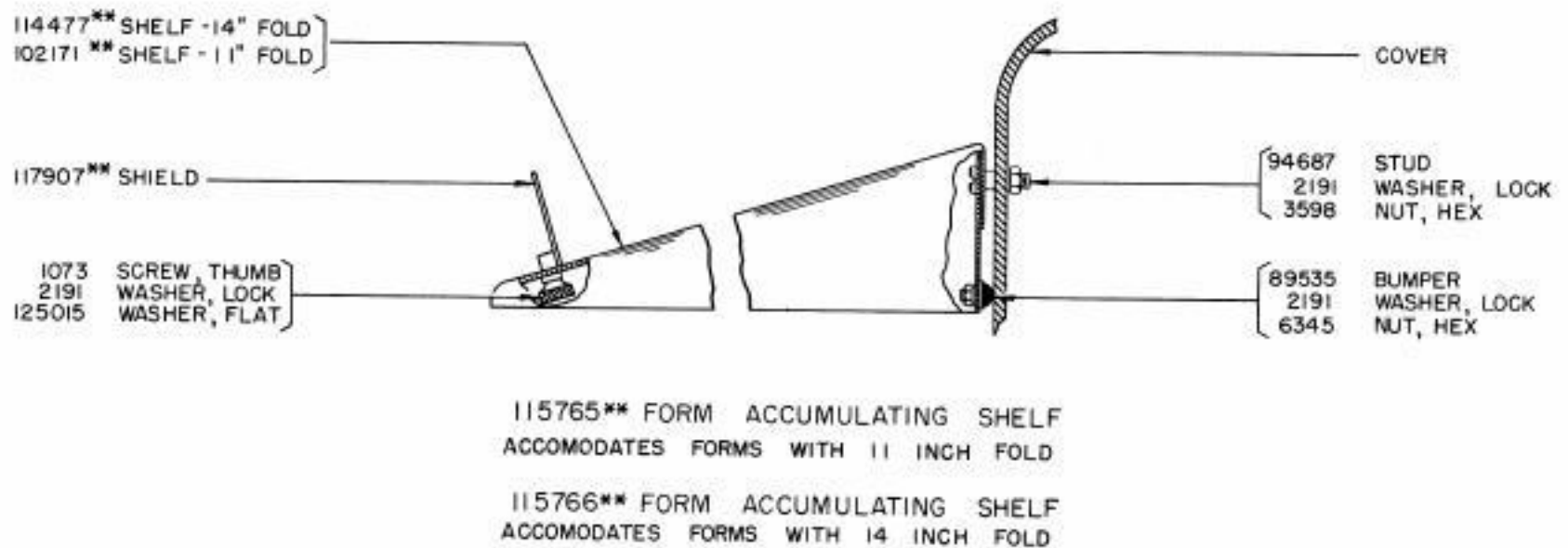
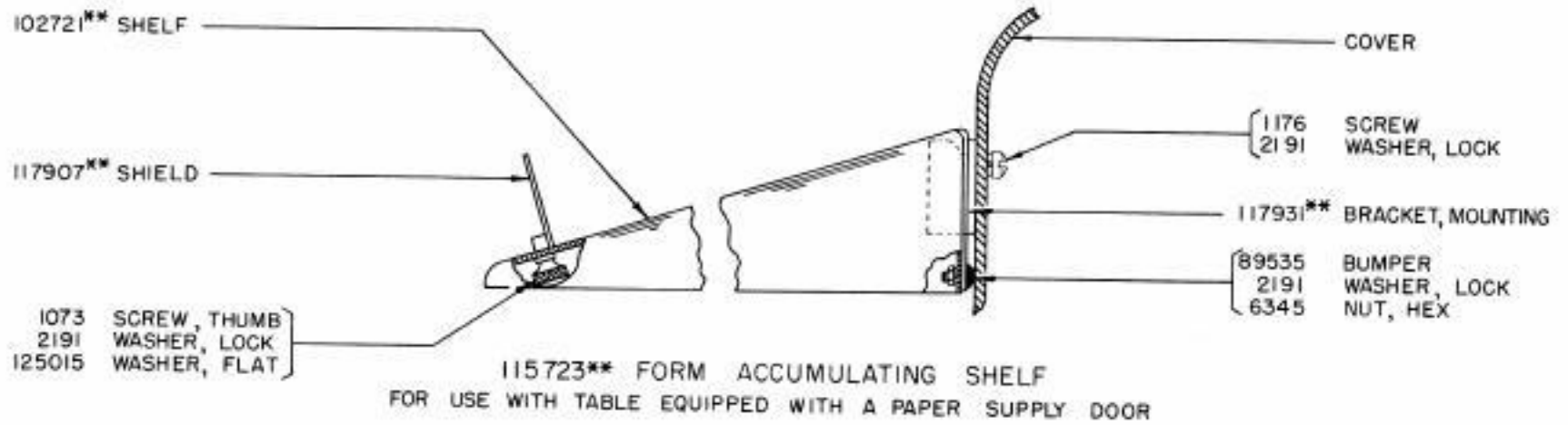

**SEE SEC. IV, PAGE 4 FOR EXPLANATION

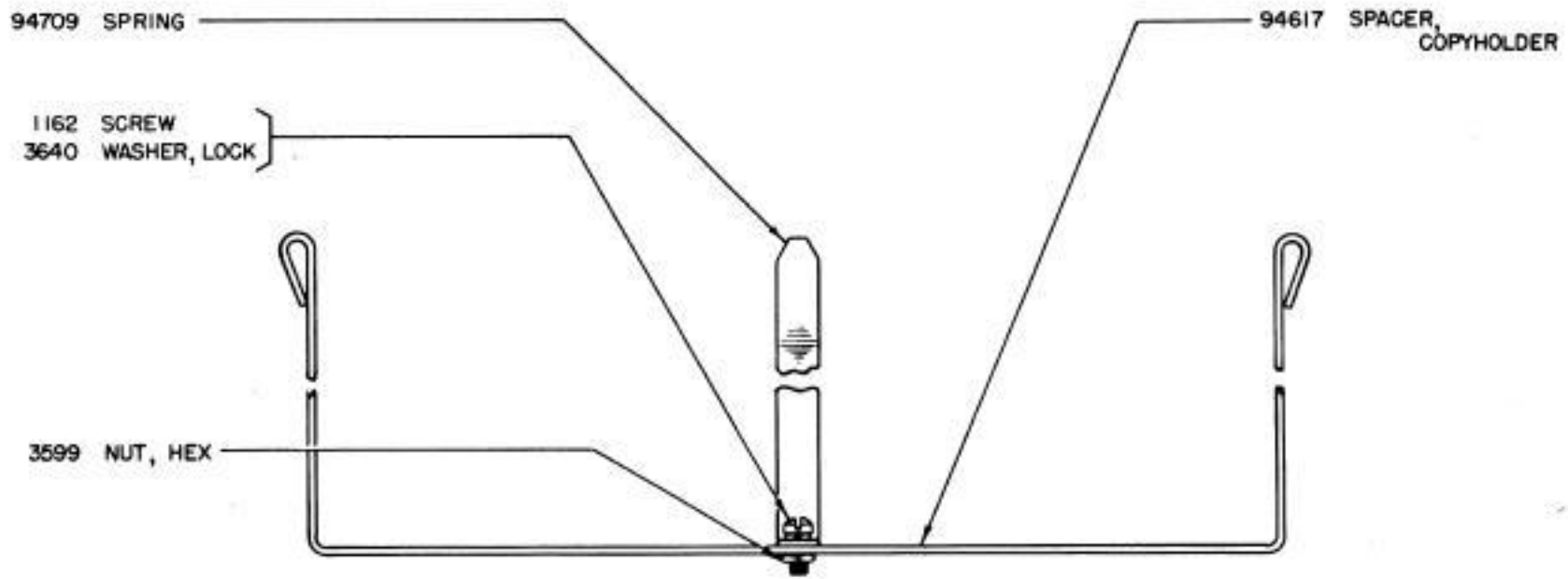

94616 SET OF PARTS FOR INSTRUCTION CARD HOLDER

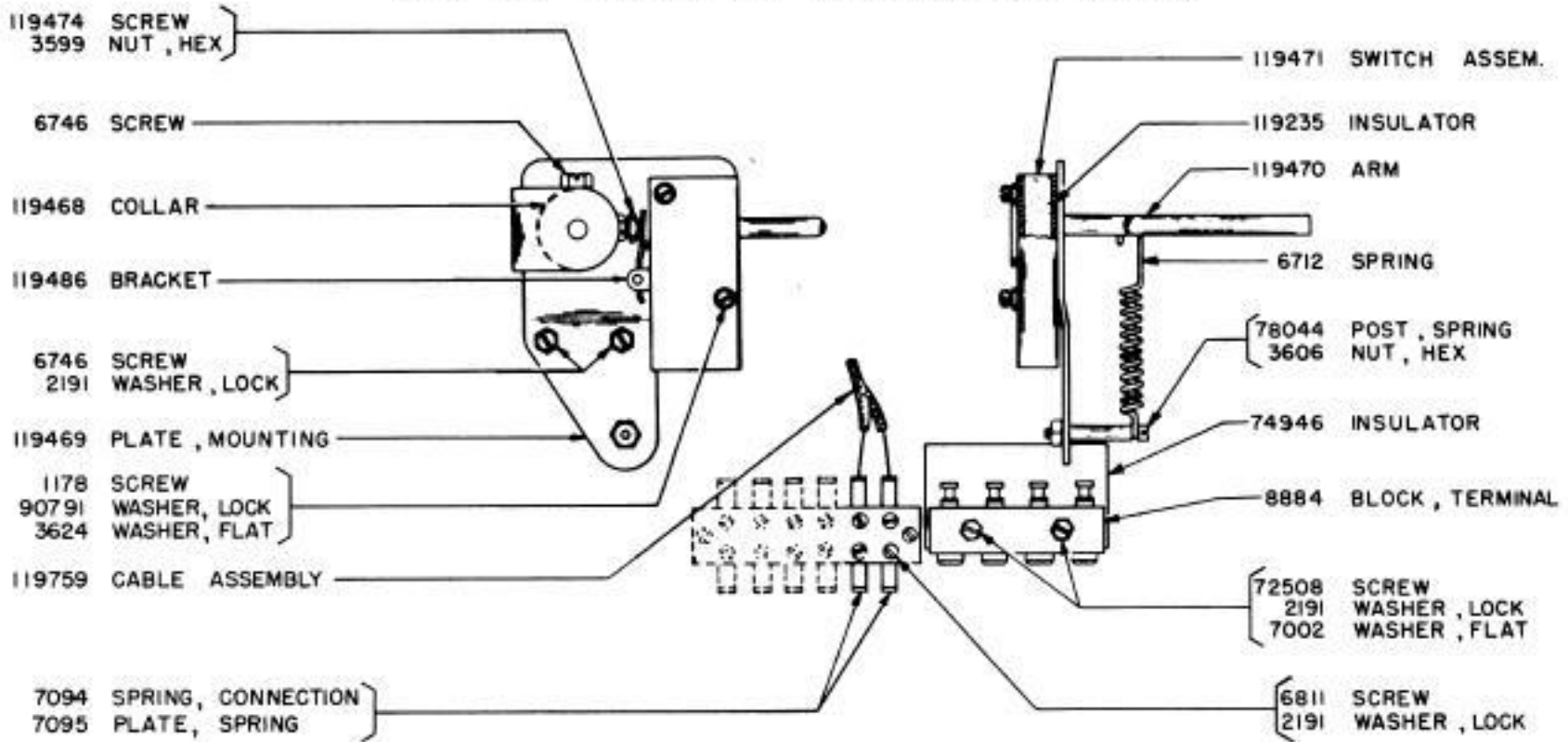

119975 SET OF PARTS FOR PAPER-OUT DEVICE

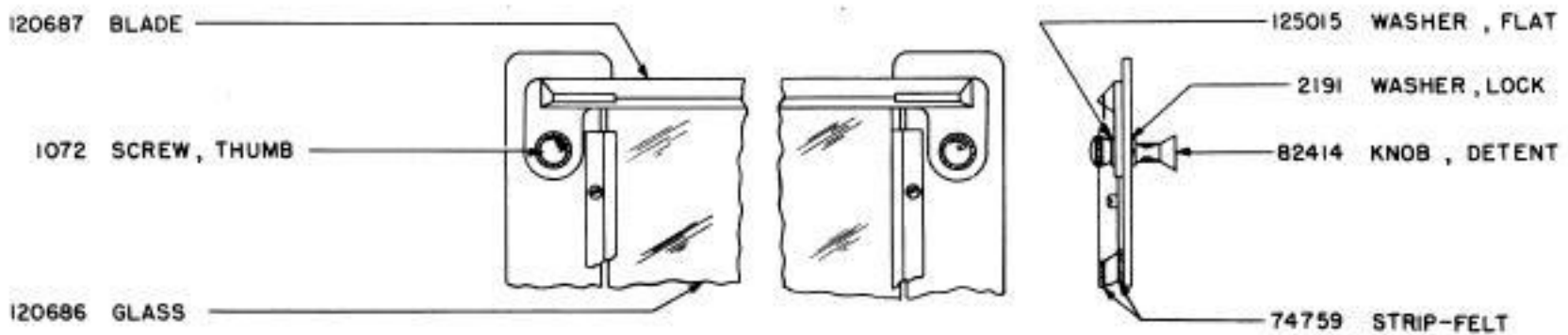

120685 SET OF PARTS TO PROVIDE TEARING EDGE WITH COVER GLASS

- 101750 TYPE BAR WITH PALLET
 - 101751 TYPE BAR WITH PALLET
 - 101752 TYPE BAR WITH PALLET
 - 74845 TYPE BAR WITH PALLET
 - 74185 PULL BAR (2)
 - 7634 SPRING (2)
- LISTED ON PAGES I-36, I-37 & I-38

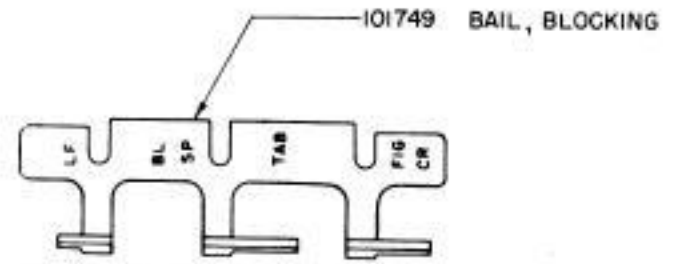

103440 SET OF PARTS TO PROVIDE FOR PRINTING AND SPACING ON BLANK AND OTHER FUNCTIONS

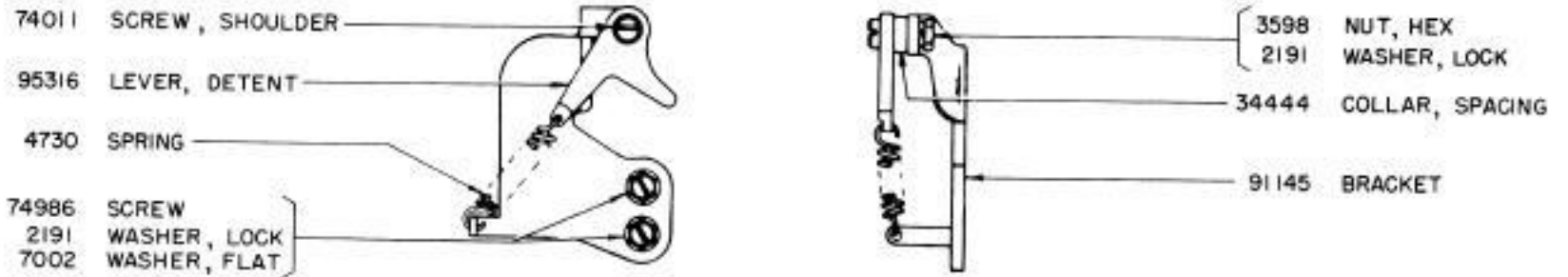

95317 SET OF PARTS TO APPLY SIGNAL DISTORTION PREVENTION DETENT

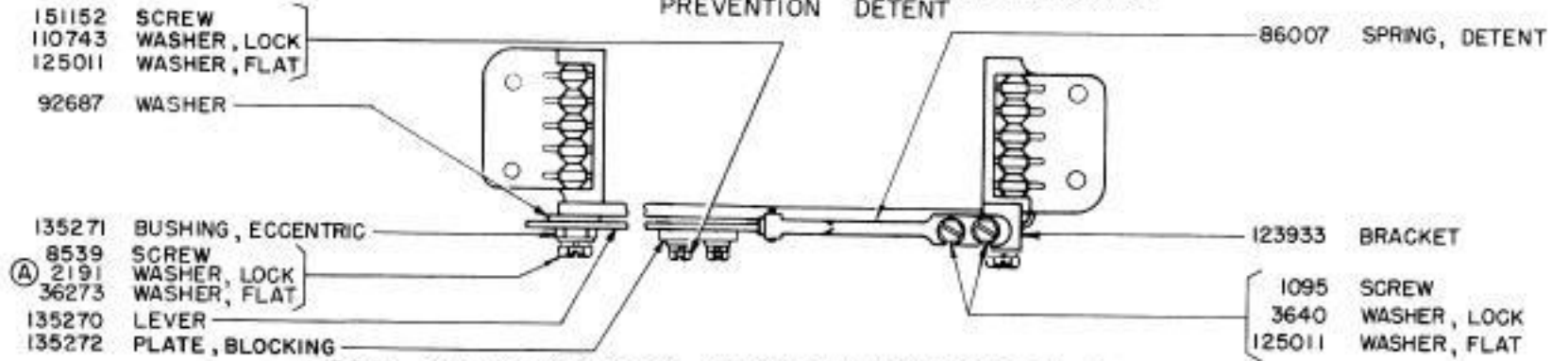

113761 SET OF PARTS TO PROVIDE "H" SUPPRESSION ON KEYBOARDS (EXCLUDES PARTS MARKED (A))



106968 SET OF PARTS TO PROVIDE FOR 84 CHARACTERS PER LINE OR 11 2/3 CHARACTERS PER INCH

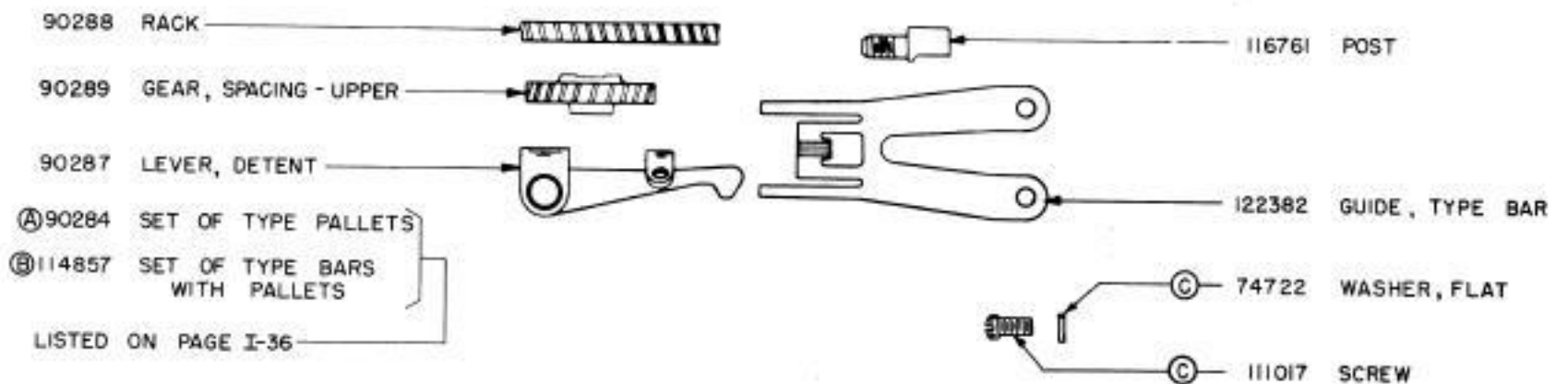

- (A) 84893 SET OF PARTS TO PROVIDE SPACING FOR 8 CHARACTERS TO THE INCH
- (B) 106939 SET OF PARTS TO PROVIDE SPACING FOR 8 CHARACTERS TO THE INCH

(C) FOR NOTE OF EXPLANATION SEE SEC. IV, PARAGRAPH FOR PAGE I-56 (A).

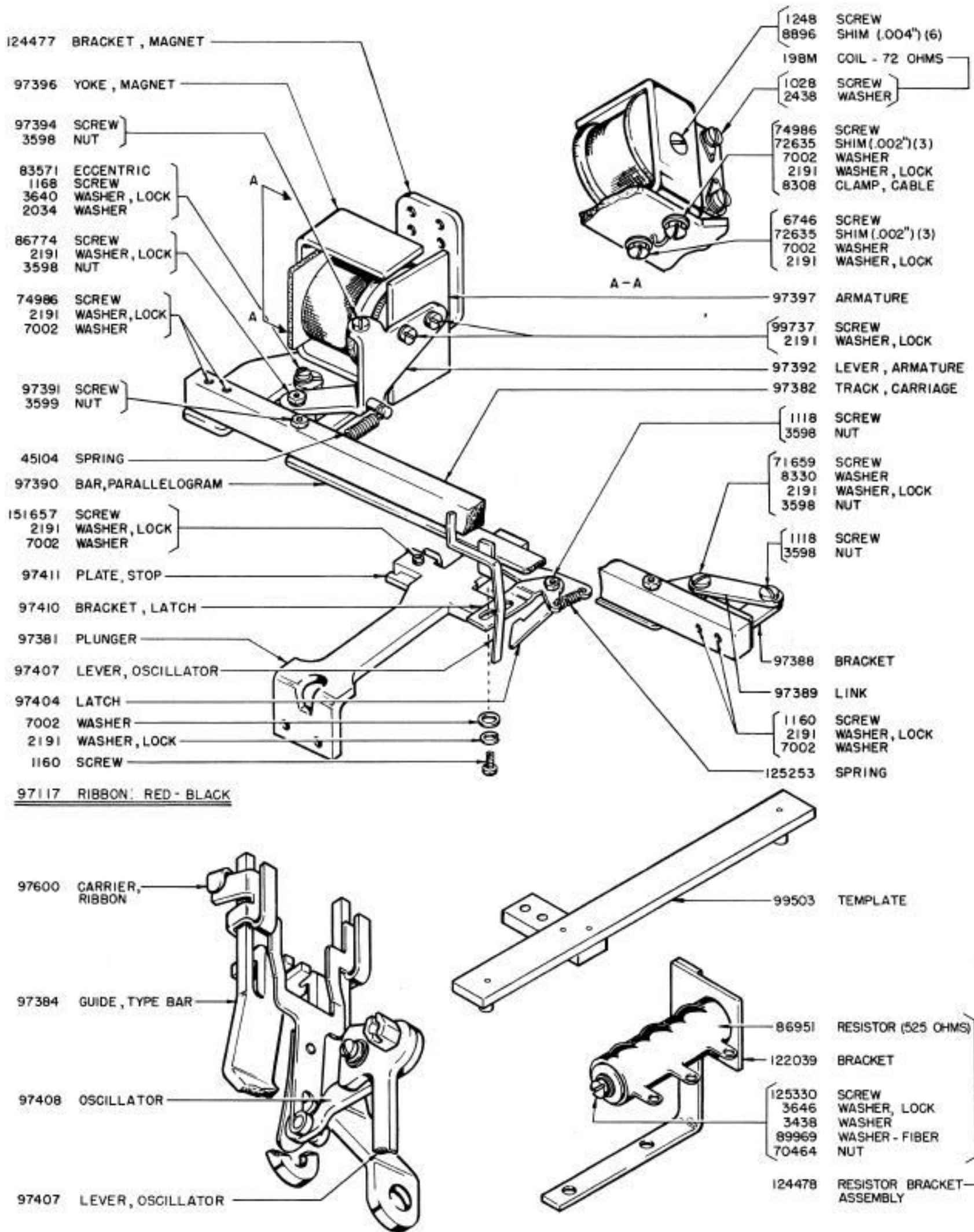

123525 SET OF PARTS FOR MANUALLY OPERATED TWO-COLOR RIBBON CONTROL
(INCLUDES ALL PARTS SHOWN ON THIS PAGE)

99502 SET OF PARTS FOR AUTOMATIC OPERATION OF TWO-COLOR RIBBON CONTROL
(INCLUDES ALL PARTS SHOWN ON THIS PAGE AND PAGE I-71, EXCLUDING PART MARKED (A))

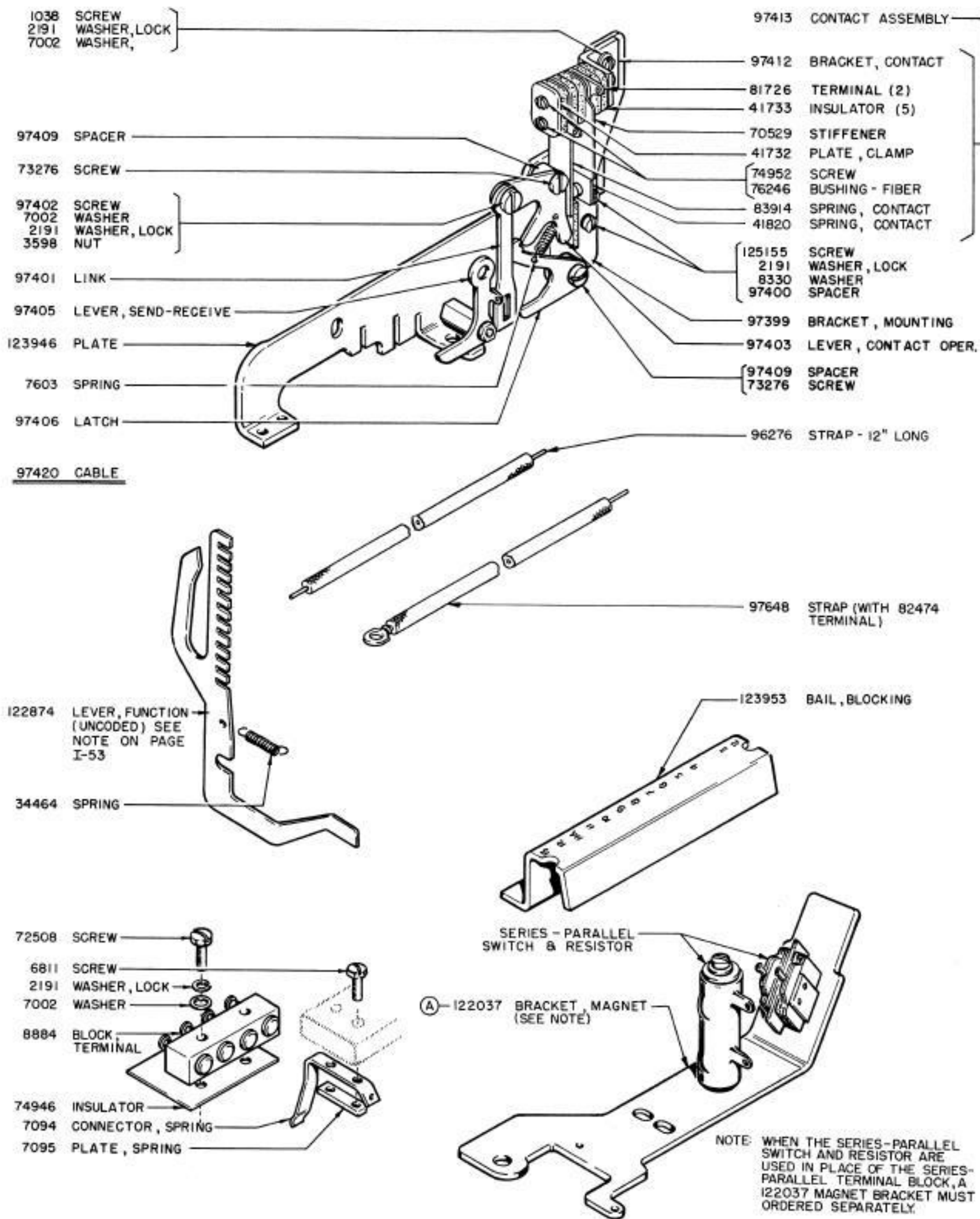

99502 SET OF PARTS FOR AUTOMATIC OPERATION OF TWO-COLOR RIBBON CONTROL
(INCLUDES ALL PARTS SHOWN ON THIS PAGE AND PAGE I-70, EXCLUDES PART MARKED (A))

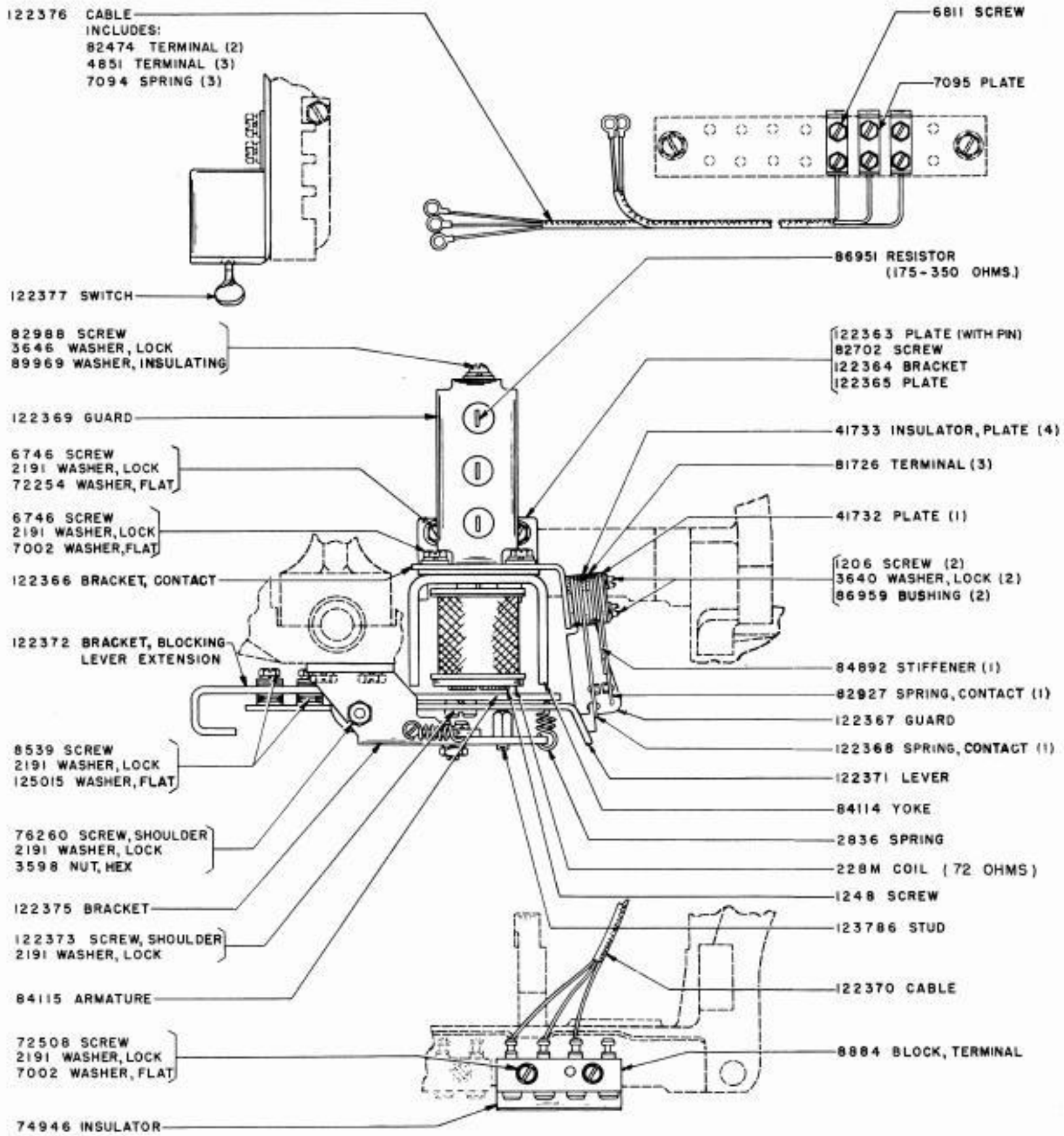

122362 SET OF PARTS FOR SWITCH CUT-IN AND AUTOMATIC
CUT-OUT OF THE HORIZONTAL TABULATION FEATURE

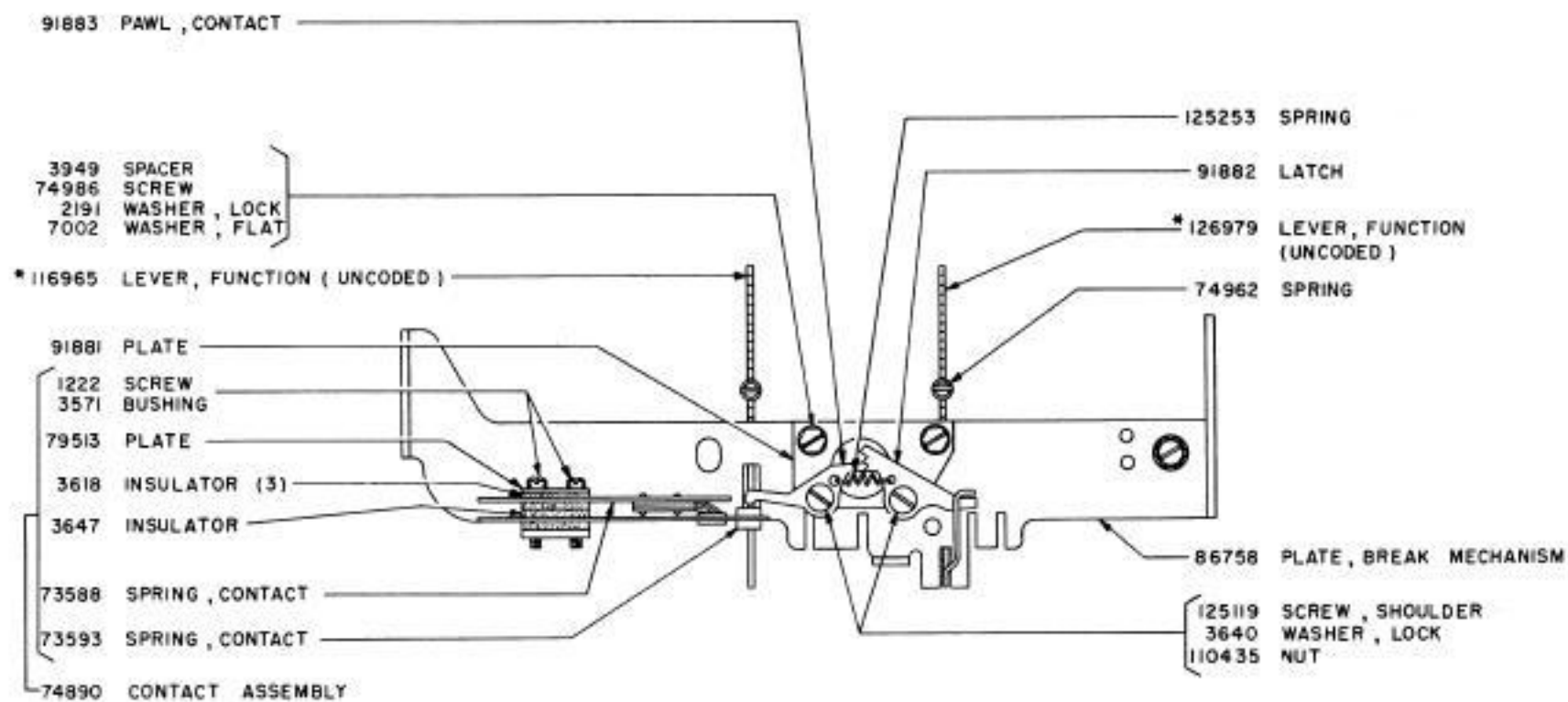

*SEE NOTE ON PAGE I-53 FOR DESIRED CODE COMBINATIONS FOR THE UNCODED FUNCTION LEVERS.

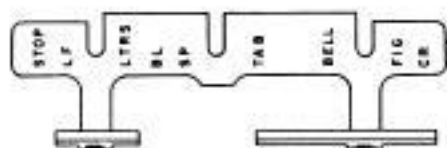

116769 BAIL , BLOCKING

82633 CABLE - TYPING UNIT
92176 CABLE - BASE

115889 SET OF PARTS TO CONTROL REPERFORATOR FROM MODEL 15 PRINTER
(FOR USE WITH HORIZONTAL TABULATION)

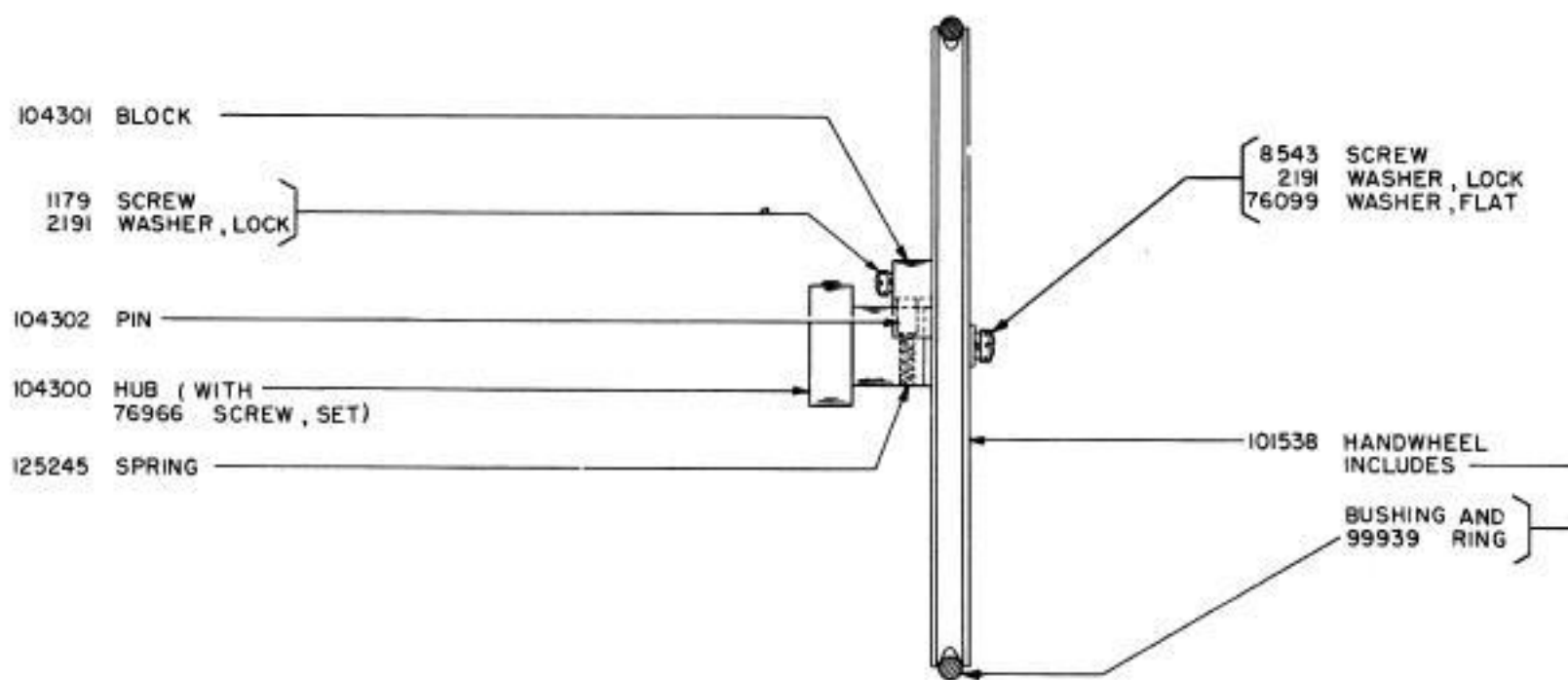

104521 HANDWHEEL ASSEMBLY

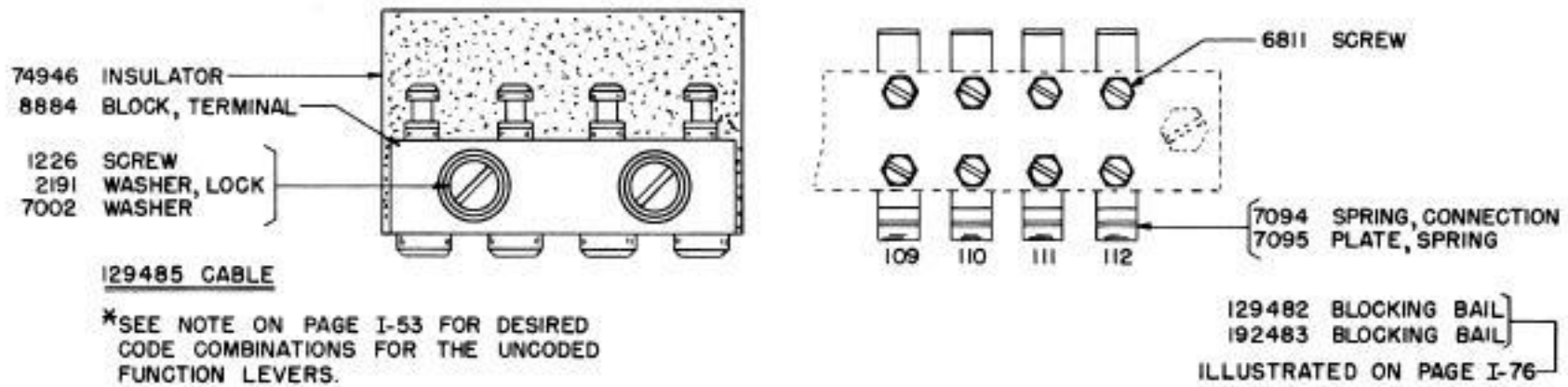
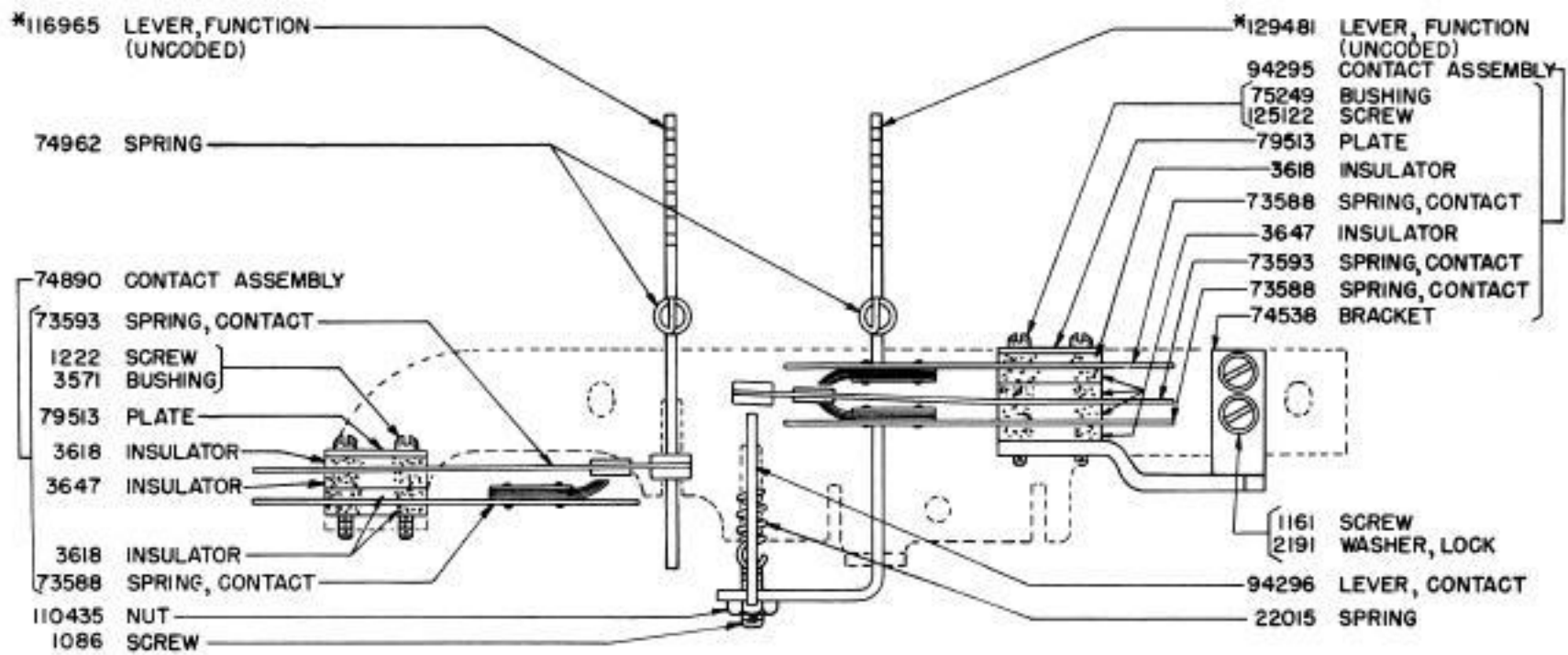

129480 SET OF PARTS TO OPEN AND CLOSE CIRCUITS EXTERNAL TO MODEL 15 PRINTER

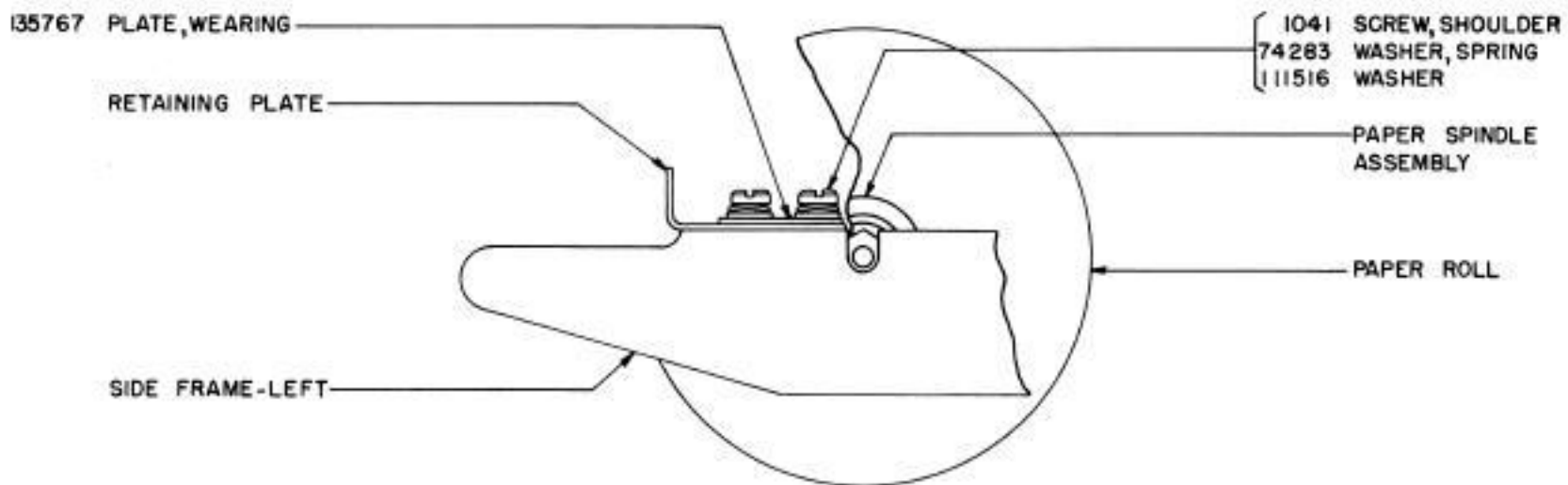

113780 SET OF PARTS FOR PRINTER HAVING EXCESSIVE WEAR ON THE LEFT SIDE FRAME (ALUMINUM)

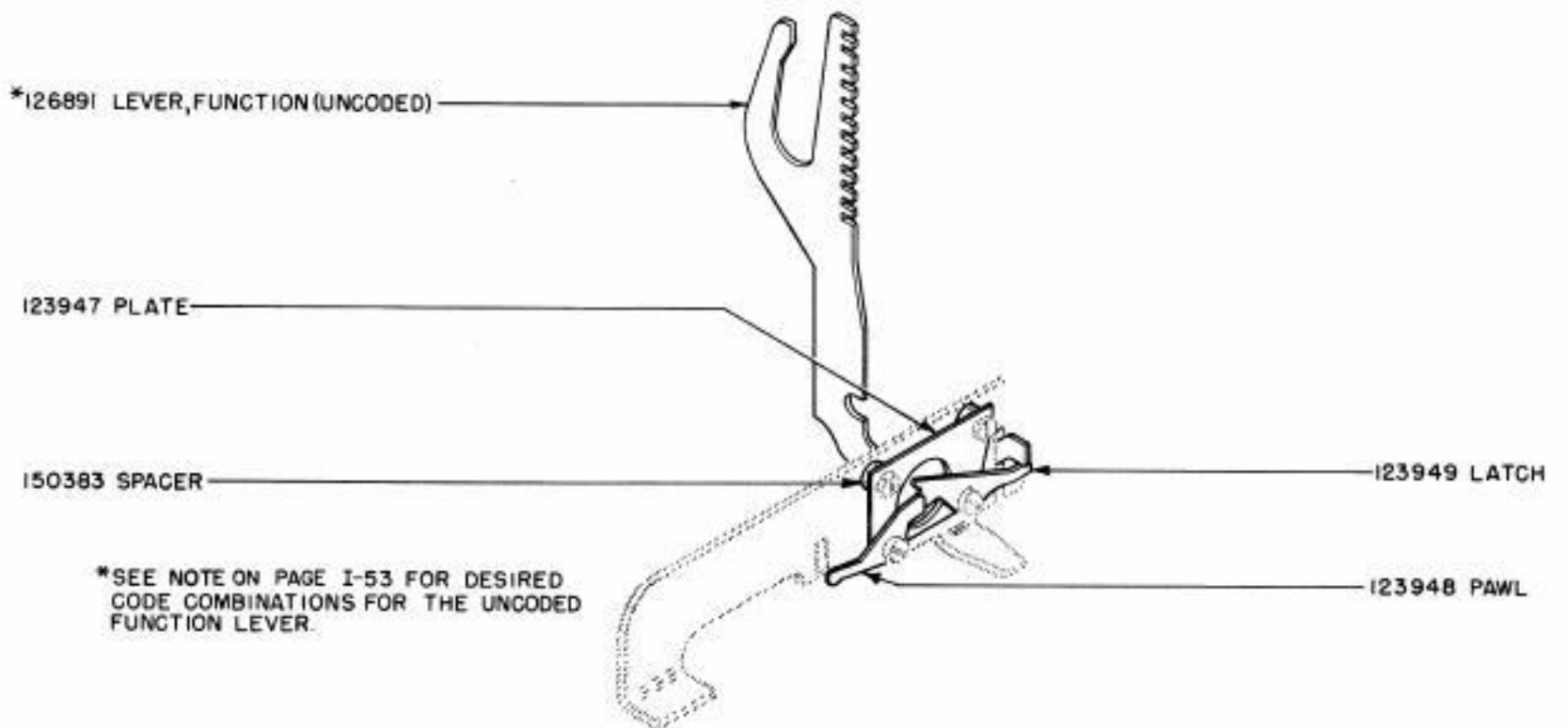

113700 SET OF PARTS FOR TWO-COLOR RIBBON PRINTER EQUIPPED WITH REPERFORATOR CONTROL

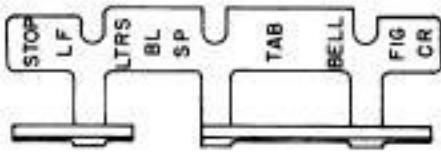

81956 (9,10)

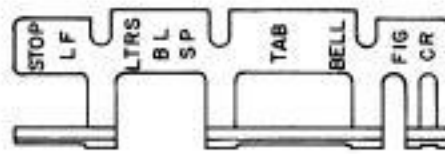

91519 (3,9,10,11)

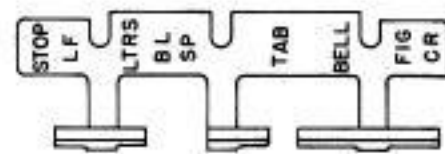

91885 (6,9,10,13)

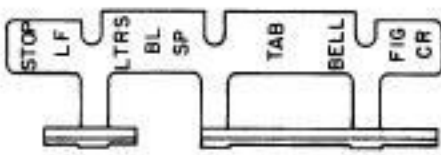

94300 (9,10,13)

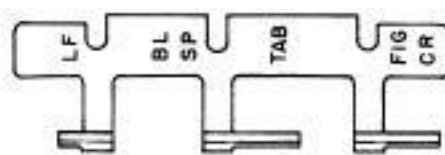

101749 (4,5,9,10,11,13)



104084 (4,5,9,10)

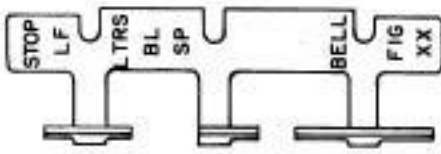

105381 (6,9,10,13)

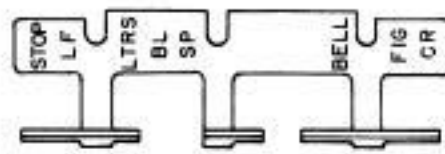

106038 (6,9,10)



116769 (7,8,9,10,13)

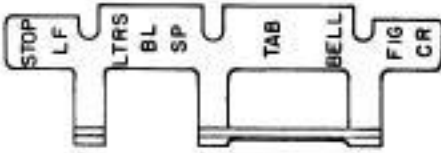

118491 (2,3,9,10,11,12,13)

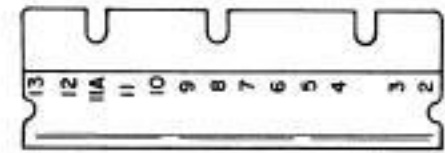

123953 (BLOCKS ALL FUNCTION LEVERS)

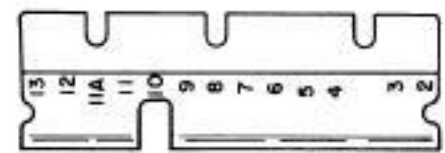

129482 (10)

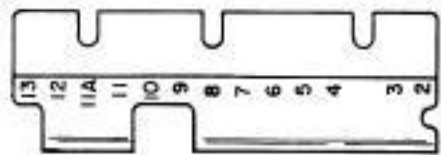

129483 (9,10,13)

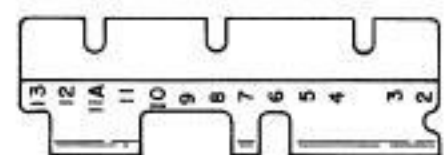

129557 (6,8,9,10,13)

FUNCTION LEVER BLOCKING BAILS
 NUMBERS IN PARENTHESIS INDICATE POSITIONS OF NON-BLOCKING
 FUNCTION LEVERS

SECTION II

BELL SYSTEM UNITS
PAGES II- 1 THROUGH II-4

THE PARTS ILLUSTRATED OR LISTED ON THIS PAGE AND THE FOLLOWING PAGES APPLY TO BELL SYSTEM UNITS.

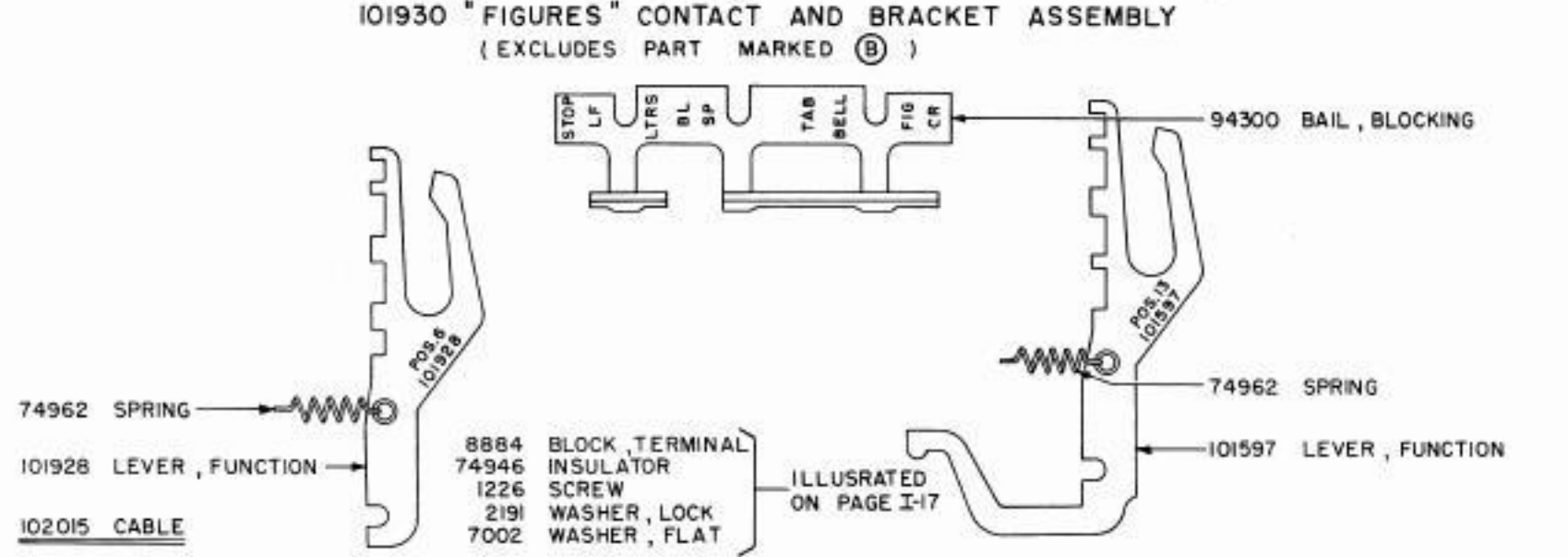
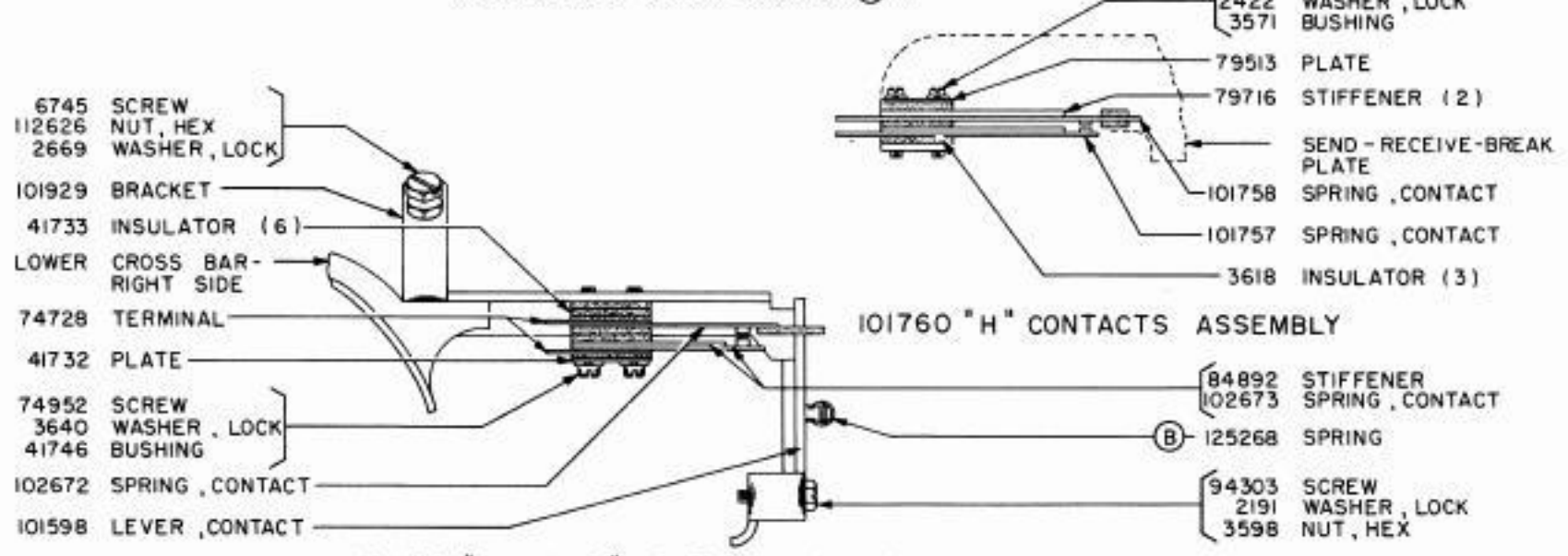
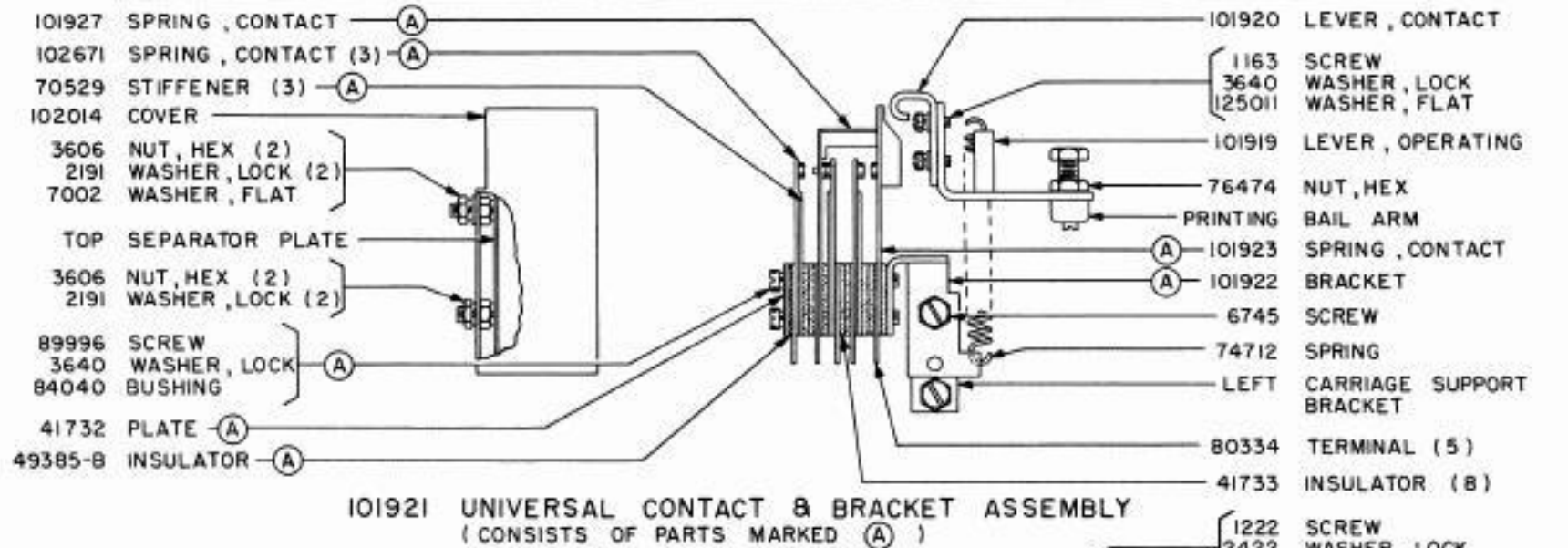

113660 SET OF PARTS TO PROVIDE SWITCHING CONTACTS ON TYPING UNITS BP99 (BELL SYSTEM 15AB) AND BPI05 (BELL SYSTEM 15AD) INCLUDES ALL PARTS LISTED ABOVE.

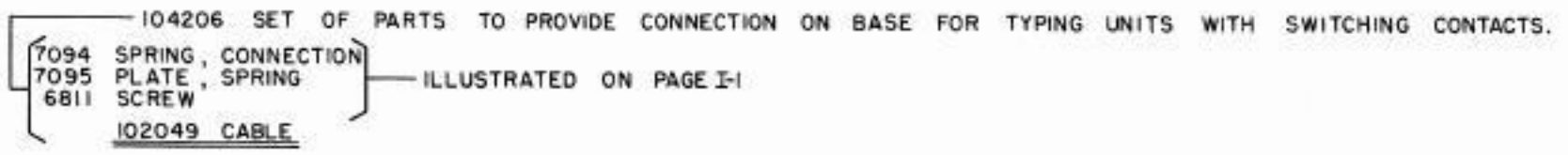

UPPER CASE "H" AND "BLANK" CONTACTS
(FOR BELL SYSTEM G. E. INSTALLATION)

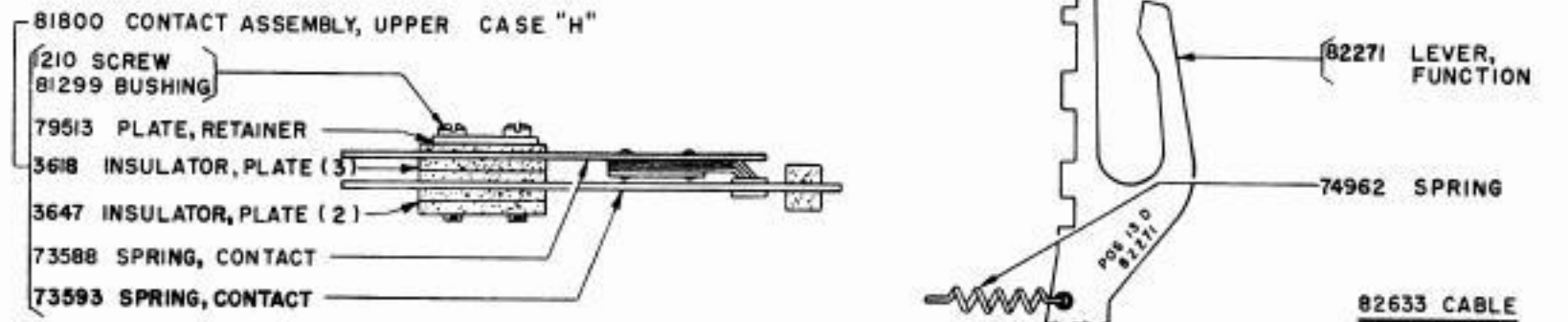

101384 SET OF PARTS FOR UPPER CASE "H" CONTACT MECHANISM
(FOR MACHINES WITHOUT THE SEND-RECEIVE-BREAK FEATURE)

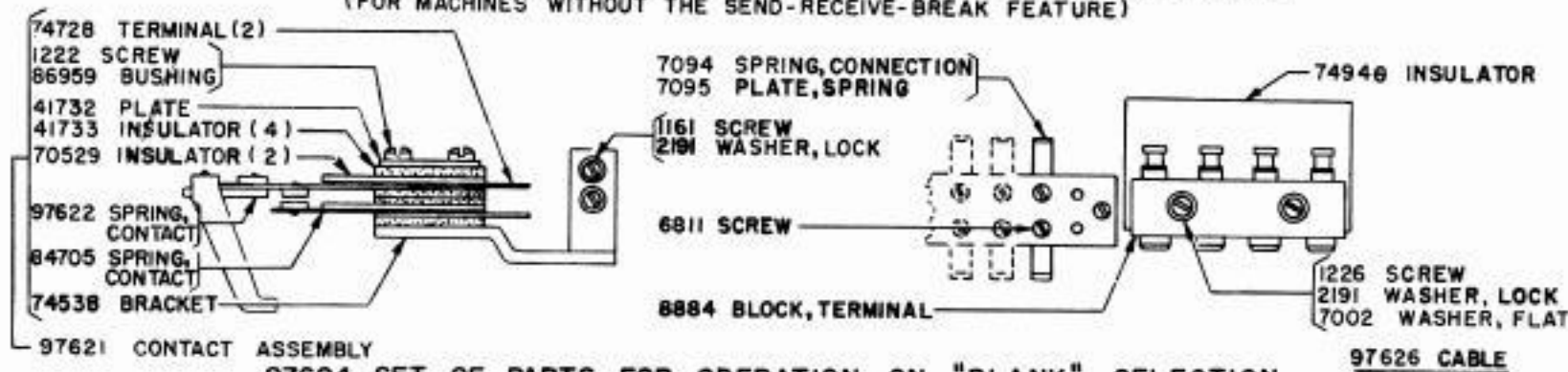

97604 SET OF PARTS FOR OPERATION ON "BLANK" SELECTION

SETS OF CONVERSION PARTS (BELL SYSTEM ONLY)

- 86192 set of parts for converting Bell System 15C** keyboard to 15B** consists of the following parts:
- | | | | |
|-------|---------------------------------|--------|---------------------------|
| 78981 | Keytop, Spring Cushion (H #)(1) | 120453 | Plate, Code (Keyboard)(1) |
| 78995 | Keytop, Spring Cushion (J ')(1) | | |
- 86193 set of parts for converting Bell System 15C** keyboard to 15A** consists of the following parts:
- | | | | |
|-------|---------------------------------|--------|----------------------------------|
| 78947 | Keytop, Spring Cushion (B ?)(1) | 78956 | Keytop, Spring Cushion (K ())(1) |
| 78948 | Keytop, Spring Cushion (C :)(1) | 78957 | Keytop, Spring Cushion (L))(1) |
| 78951 | Keytop, Spring Cushion (F !)(1) | 78959 | Keytop, Spring Cushion (N ,)(1) |
| 78953 | Keytop, Spring Cushion (H &)(1) | 78966 | Keytop, Spring Cushion (V ;)(1) |
| 78955 | Keytop, Spring Cushion (J ')(1) | 120453 | Plate, Code (Keyboard)(1) |
- 87693 set of parts for Bell System name plate (with window) consists of the following parts:
- | | | | |
|-------|-----------------|-------|------------|
| 92003 | Plate, Name (1) | 91621 | window (1) |
|-------|-----------------|-------|------------|
- 87868 set of parts for converting Bell System 15S and 15T typing units to 15J and 15L consists of the following parts:
- | | | | |
|-------|-------------------------------------|-------|----------------------------|
| 81800 | Upper Case "H" Contact Assembly (1) | 82788 | Spring, Function Lever (1) |
| 82271 | Lever, Function (1) | 82633 | Cable (1) |
- 90253 set of parts for converting Bell System 15S typing unit to 15E consists of the following parts:
- | | | | |
|-------|---------------------------------|--------|---------------------------------|
| 74185 | Bar, Pull (1) | 74765 | Pallet, Type (H #)(1) |
| 7634 | Spring, Pull Bar (1) | 120452 | Plate, Code (Typing Unit) (1) |
| 74642 | Bar, Type (with pallet)(. .)(1) | 83408 | Screws, Code Plate Mounting (2) |
| 74318 | Pallet, Type (J ')(1) | | |

*See Sec. IV, Page 4 for explanation

- 90254 set of parts for converting Bell System 15K typing unit to 15F consists of the following parts:
- | | | | | | |
|-------|---------------------------------|-----|--------|-----------------------------|----------|
| 74038 | Lever, Function | (1) | 74318 | Pallet, Type | (J ')(1) |
| 74185 | Bar, Pull | (1) | 74765 | Pallet, Type | (H #)(1) |
| 7634 | Spring, Pull Bar | (1) | 120452 | Plate, Code (Typing Unit) | (1) |
| 74642 | Bar, Type (with pallet)(. .)(1) | | 83408 | Screws, Code Plate Mounting | (2) |
- 90255 set of parts for converting Bell System 15I typing unit to 15G consists of the following parts:
- | | | | | | |
|-------|---------------------------------|----------|--------|-----------------------------|----------|
| 74185 | Bar, Pull | (1) | 74765 | Pallet, Type | (H #)(1) |
| 7634 | Spring, Pull Bar | (1) | 120452 | Plate, Code (Typing Unit) | (1) |
| 74642 | Bar, Type (with Pallet)(. .)(1) | | 83408 | Screws, Code Plate Mounting | (2) |
| 74318 | Pallet, Type | (J ')(1) | | | |
- 90256 set of parts for converting Bell System 15K typing unit to 15H consists of the following parts:
- | | | | | | |
|-------|---------------------------------|-----|--------|-----------------------------|----------|
| 74038 | Lever, Function | (1) | 74318 | Pallet, Type | (J ')(1) |
| 74185 | Bar, Pull | (1) | 74765 | Pallet, Type | (H #)(1) |
| 7634 | Spring, Pull Bar | (1) | 120452 | Plate, Code (Typing Unit) | (1) |
| 74642 | Bar, Type (with Pallet)(. .)(1) | | 83408 | Screws, Code Plate Mounting | (2) |
- 91827 set of parts for converting 74839 (Bell System 15A) motor unit to 91830 (Bell System 15J) motor unit consists of the following parts:
- | | | | | | |
|-------|------------------------|-----|--------|--------------------------|-----|
| 91761 | Bracket | (1) | 2191 | Washer, Lock | (2) |
| 78206 | Resistor Unit Assembly | (1) | 91762 | Cable | (1) |
| 6746 | Screw | (2) | 120460 | Plate, Code (Motor Unit) | (1) |
| 7002 | Washer, Flat | (2) | | | |
- 91828 set of parts for converting 74840 (Bell System 15B) motor unit to 91831 (Bell System 15K) motor unit consists of the following parts:
- | | | | | | |
|-------|------------------------|-----|--------|--------------------------|-----|
| 91761 | Bracket | (1) | 2191 | Washer, Lock | (2) |
| 78206 | Resistor Unit Assembly | (1) | 91763 | Cable | (1) |
| 6746 | Screw | (2) | 120460 | Plate, Code (Motor Unit) | (1) |
| 7002 | Washer, Flat | (2) | | | |
- 92232 set of parts for converting Bell System 15E** keyboard to 15D** consists of the following parts:
- | | | | |
|-------|---------------------------------|--------|---------------------------------------|
| 78947 | Keytop, Spring Cushion (B ?)(1) | 78957 | Keytop, Spring Cushion (L))(1) |
| 78948 | Keytop, Spring Cushion (C :)(1) | 78959 | Keytop, Spring Cushion (N ,)(1) |
| 78951 | Keytop, Spring Cushion (F !)(1) | 78966 | Keytop, Spring Cushion (V ;)(1) |
| 78953 | Keytop, Spring Cushion (H &)(1) | 120453 | Plate, Code (Keyboard)(1) |
| 78955 | Keytop, Spring Cushion (J ')(1) | 120456 | Plate, Code (Teletypewriter Base) (1) |
| 78956 | Keytop, Spring Cushion (K)(1) | | |
- 111182 set of parts for converting Bell System 15F** keyboard to 15G** consists of the following parts:
- | | | | |
|-------|-----------------------------------|--------|-----------------------------------|
| 78961 | Keytop, Spring Cushion (P O)(1) | 78987 | Keytop, Spring Cushion(N 7/8)(1) |
| 78982 | Keytop, Spring Cushion (F 1/2)(1) | 78988 | Keytop, Spring Cushion(K 1/2)(1) |
| 78983 | Keytop, Spring Cushion(L 3/4)(1) | 78993 | Keytop, Spring Cushion (J ')(1) |
| 78984 | Keytop, Spring Cushion(C 1/8)(1) | 82607 | Keytop, Spring Cushion(H Stop)(1) |
| 78985 | Keytop, Spring Cushion(J 3/8)(1) | 120453 | Plate, Code (Keyboard)(1) |
| 78986 | Keytop, Spring Cushion(B 5/8)(1) | | |

**See Sec. IV, Page 4 for explanation

CABLES WITH PART NUMBERS LISTED BELOW APPLY TO BELL SYSTEM UNITS

BASE

- 74574 Line } Associated with pulling magnet (for use with three terminal blocks -
- 74573 Power } Twelve terminals each).
- 91770 Line } Associated with holding magnet (for use with one terminal block -
- 91769 Power } Twenty-six terminals).
- 91789 Line Relay - Part of 91786 set of parts
- 74575 Line Relay

KEYBOARD

- 114749 For use with line test key (cam type).
- 92238 For use without local test.
- 92237 For use with line test key locking and non-locking - push type (color coded).
- 74572 For use with line test key locking and non-locking - push type (all black).

TYPING UNIT

- 91277 Selector unit (holding magnets) - with 8884 terminal block.
- 91898 Selector unit (holding magnets) - without 8884 terminal block (for use with 94490 series-parallel switch).
- 124591 Selector unit (holding magnets) (for use with 113703 terminal block assembly).
- 74625 Selector unit (pulling magnets).
- 82633 For upper case "H" contacts.
- 74789 For motor stop contacts.

BELL SYSTEM CODE DESIGNATION PLATES

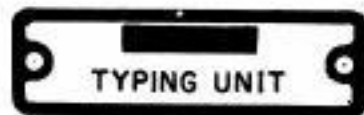

120452



120453

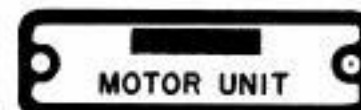

120460

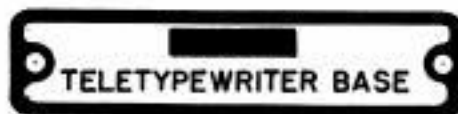

120456

TWO 83408 SCREWS ARE USED TO SECURE ANY OF THE ABOVE CODE PLATES.

SECTION III

OLD STYLE PARTS

PAGES III-1 THROUGH III-3

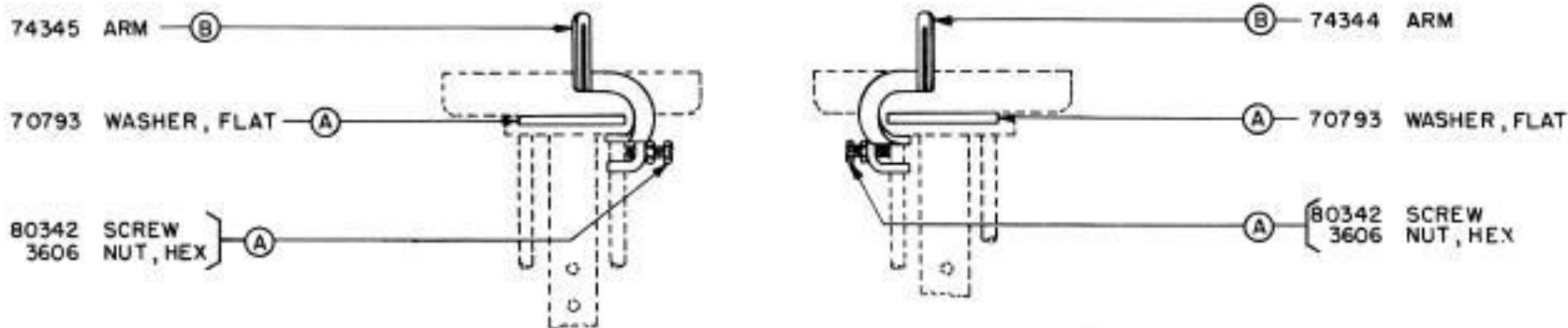

RIBBON FEED PARTS
(OLD STYLE - SEE PAGE I-21 FOR NEW STYLE)

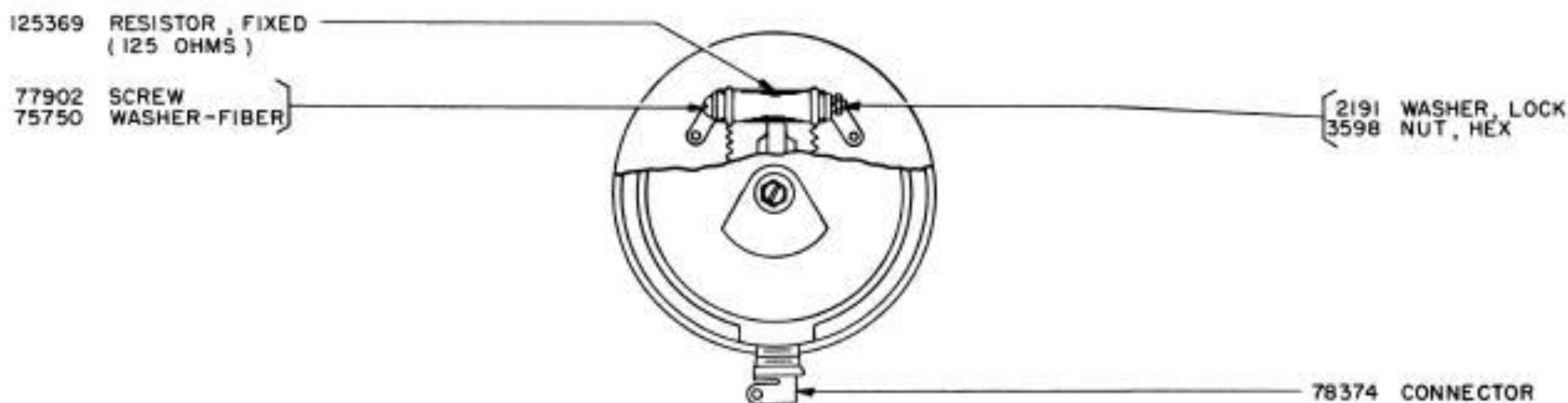

REMOTE SIGNAL BELL - OLD STYLE
(SEE PAGE I-65 FOR NEW STYLE)

82363 SIGNAL BELL SUPERSEDED BY 110763
80564 SIGNAL BELL SUPERSEDED BY 110761
80565 SIGNAL BELL SUPERSEDED BY 110762

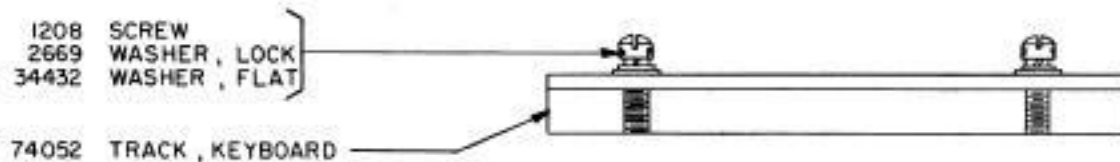

KEYBOARD TRACK
(SEE PAGE I-1 FOR NEW STYLE)

(A) AND (B) SEE SEC. IV FOR EXPLANATION

(ONLY PARTS LISTED ABOVE ARE AVAILABLE FOR MAINTENANCE)

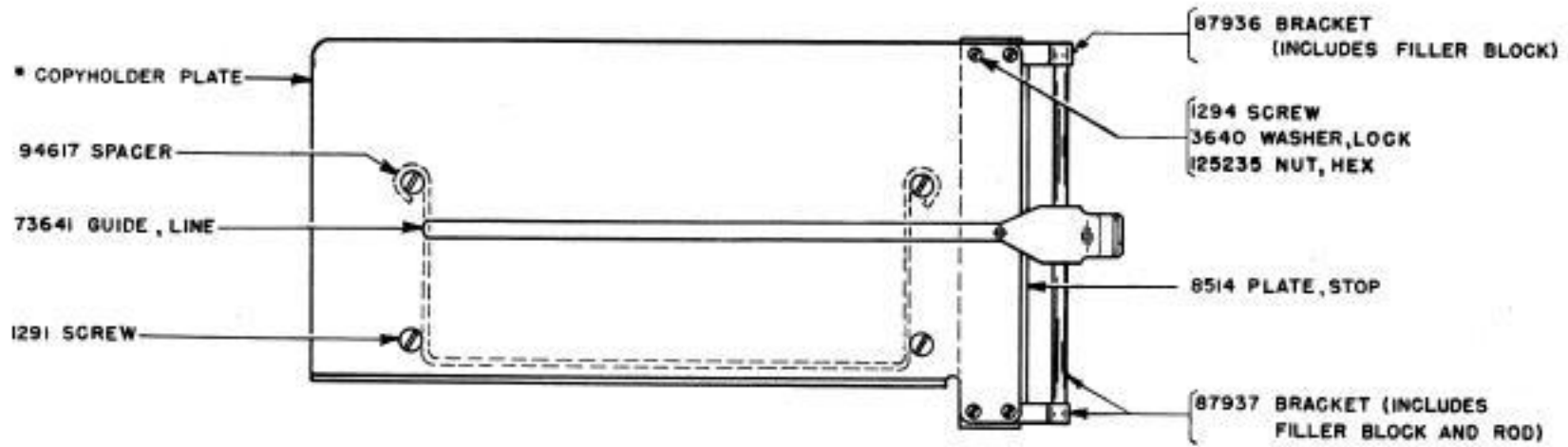

COPYHOLDER - 6" (OLD STYLE)
(SEE PAGE I-49 FOR NEW STYLE)

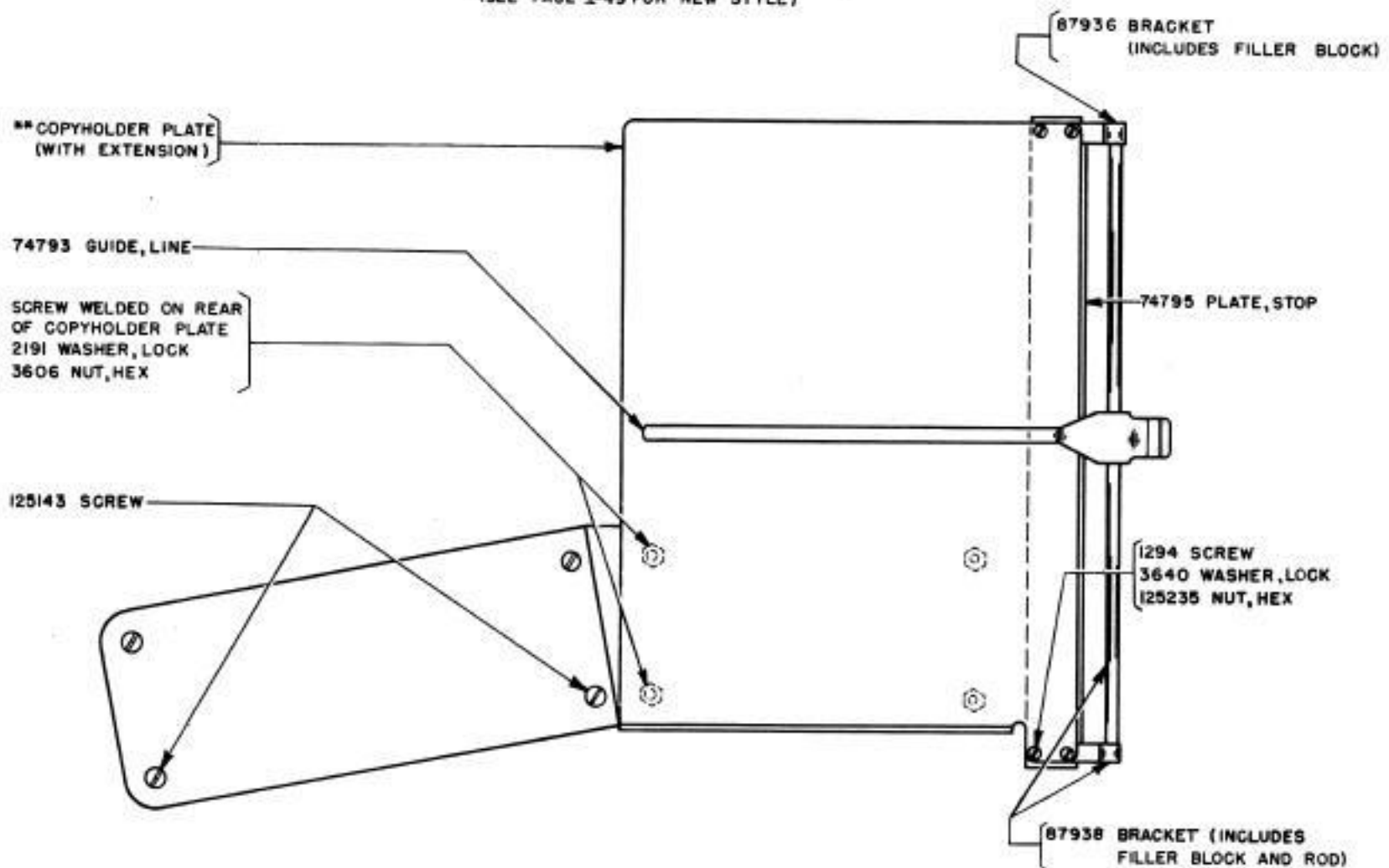

COPYHOLDER - 12" (OLD STYLE)
(SEE PAGE I-49 FOR NEW STYLE)

* THE OLD STYLE COPYHOLDER PLATE IS NO LONGER AVAILABLE. WHEN IT BECOMES NECESSARY TO REPLACE AN OLD STYLE COPYHOLDER PLATE, A NEW STYLE COPYHOLDER PLATE, SHOWN ON PAGE I-49, ALONG WITH ONE 110920 ROD, ONE 2191 LOCK WASHER AND ONE 3598 NUT SHOULD BE ORDERED INSTEAD.

** THE OLD STYLE COPYHOLDER PLATE (WITH EXTENSION) IS NO LONGER AVAILABLE. WHEN IT BECOMES NECESSARY TO REPLACE AN OLD STYLE COPYHOLDER PLATE (WITH EXTENSION), A COMPLETE NEW STYLE 12" COPYHOLDER (WITH EXTENSION), SHOWN ON PAGE I-49, SHOULD BE ORDERED INSTEAD.

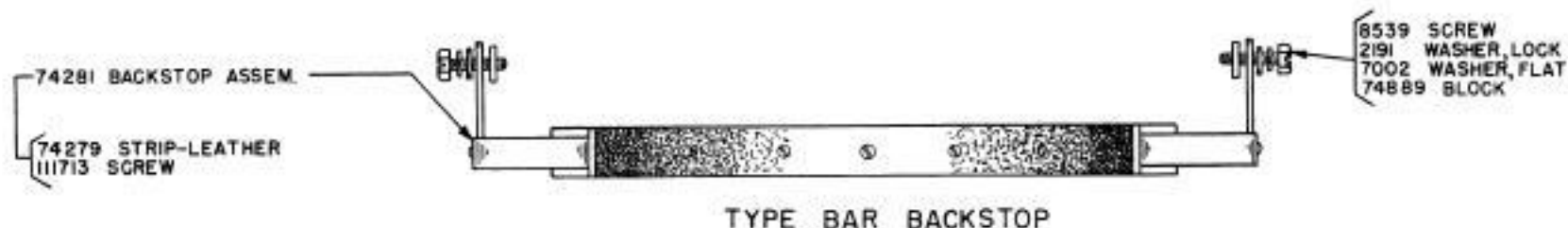

TYPE BAR BACKSTOP

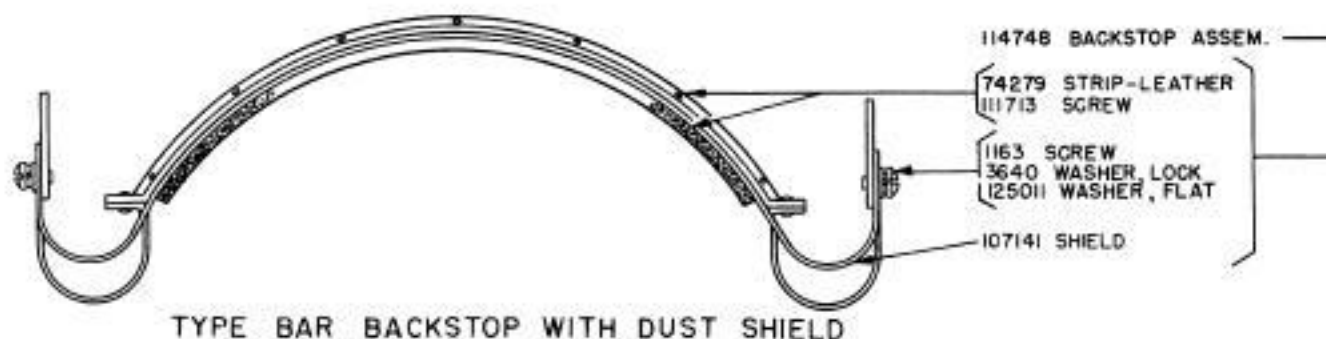

TYPE BAR BACKSTOP WITH DUST SHIELD

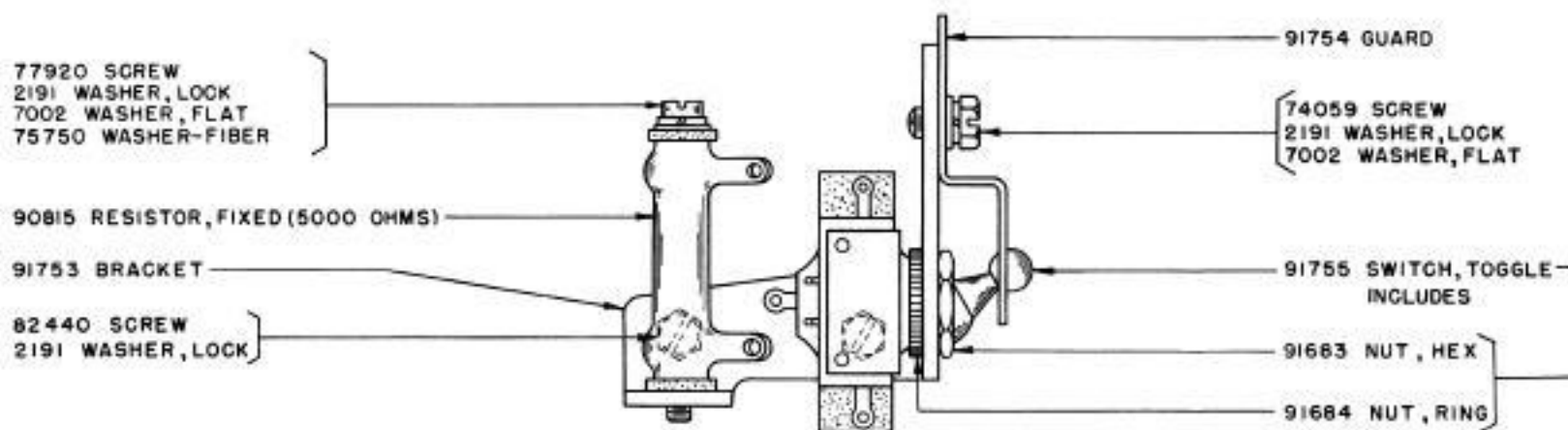
91898 CABLE

94490 "SERIES PARALLEL" SWITCH & RESISTOR BRACKET ASSEMBLY

(ALSO SEE SEC IV, PARAGRAPH FOR PAGE I-31 (B))

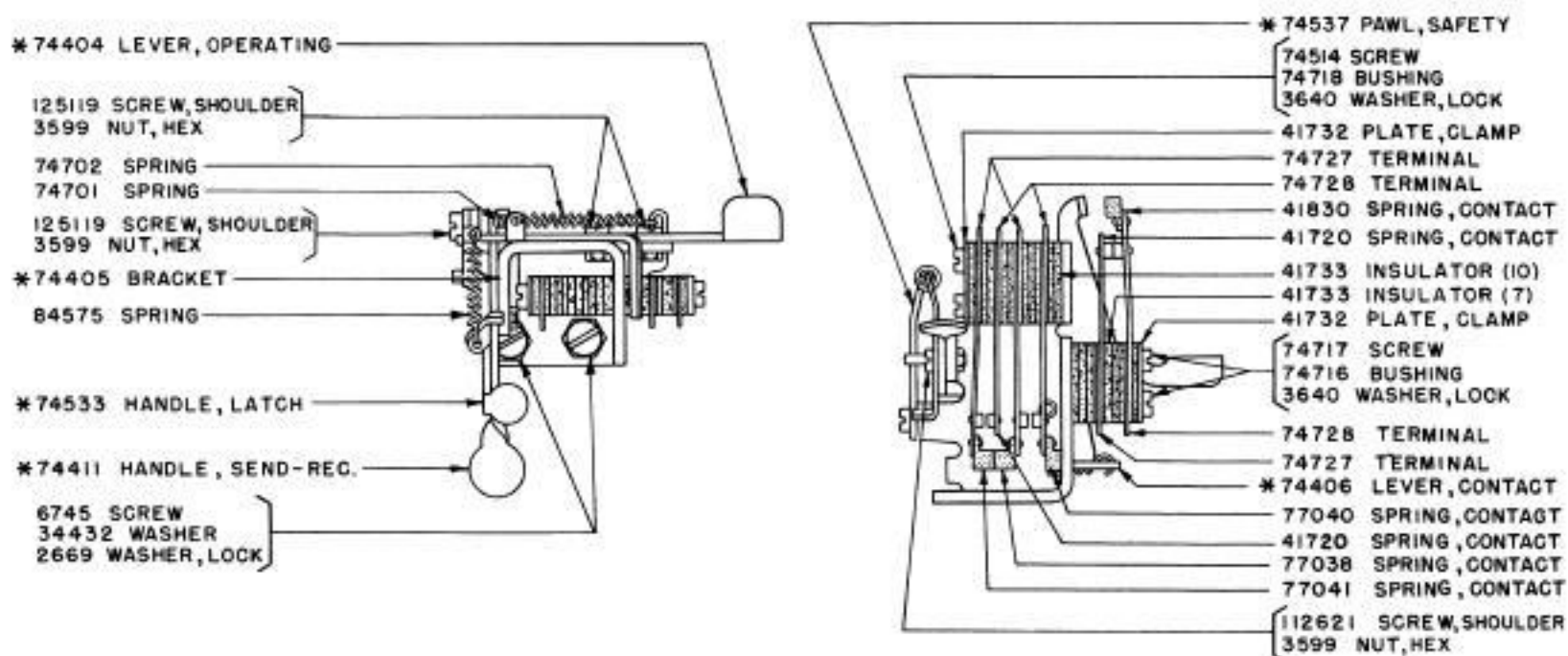

74428 SEND-REC-BREAK MECHANISM ASSEMBLY

NOTE: * INDICATES AN OLD STYLE PART WHICH IS NO LONGER FURNISHED. WHEN IT BECOMES NECESSARY TO REPLACE ANYONE OF THESE PARTS A COMPLETE NEW STYLE 82917 SEND-REC. BREAK MECHANISM ASSEM. SHOULD BE ORDERED. ALL OTHER OLD STYLE PARTS ARE STILL AVAILABLE FOR MAINTENANCE PURPOSES.

SECTION IV

NOTES OF EXPLANATION

PAGES IV-1 THROUGH IV-4

PAGE I-1

- (A) The 74720 thumb screw has been redesigned to include a captive lock washer, preassembled. The 2322 lock washer previously used is still available for use with the old style thumb screw.

PAGE I-2

- (A) The 99816 base has provisions for mounting the 99745 line and selector jack. The 74719 base does not have such provisions.

PAGE I-5

- (A) The 2980 retaining strap is used only when the 74430 bracket and 73670 terminal block are not used.
- (B) The 103746 resistor (5 ohm) is added in series with the 1 mf. capacitor in the governor circuit to improve the effect of this circuit when D.C. power is used.

PAGE I-6

- (B) The 1245 screws are replaced by 86850 screws when mounting capacitor on top of base (without 74814 relay mounting assembly).

PAGE I-12

- (A) In order to obtain a more flexible adjustment the 6800 screw (shoulder) has been replaced by a 107485 screw (eccentric shoulder).

PAGE I-16

- (A) To permit adjustment of the selector clutch torque without the necessity of removing the selector cam sleeve, a 119540 keyed nut, a 122974 capstan nut, and a 122838 spacer replace the 72517 nut and 72515 keyed nut.

Shims formerly supplied to adjust the selector clutch torque in the field are still available under the following numbers:

96763 Shim (0.012" thick) 96764 Shim (0.016" thick) 96765 Shim (0.020" thick)

Old and new style parts are not individually interchangeable but are interchangeable in sets.

PAGE I-19

- (A) In order to eliminate the possibility of erroneously gaining a fifth pulse, the following changes have been made:

The 74184 code bar No. 5D has been replaced by a 114432 code bar No. 5N which has additional portions cut away to reduce its weight. The 74025 bell crank No. 5 (0.050" thick) has been replaced by a 114139 bell crank No. 5 (0.025" thick). The 74199 bushing (shoulder 0.057" thick) has been replaced by a 113872 bushing (shoulder 0.032" thick). When either the 74025 bell crank or the 74199 bushing requires replacement, both parts must be replaced by new parts as the new style parts are not interchangeable with old style parts.

- (B) The 87509 spring post (threaded) has replaced the 8486 spring post (not threaded). The 74244 printing bail, which is now tapped, includes the 87509 spring post. Old style 74244 printing bails (not tapped) necessitate the use of the 8486 spring post for replacement purposes.

PAGE I-23

- (A) The 74041 type bar basket has been modified for use with two-color ribbon control and has been assigned part number 97380. It should be ordered under this number when required for use with two-color control.

PAGE I-24

- (A) The 74264 platen shaft has been redesigned, but retains its original number. The new design differs from the old design in that it has a hole near the left end for a 104995 pin instead of a tapped hole for the 80255 screw. The 80255 screw, however, is still available for maintenance purposes on the old style shafts.
- (B) The 74446 line feed ratchet (33 teeth) and the 74447 detent ratchet (33 teeth) are used for the standard single line feed of six lines per inch.
- (C) On typing units equipped with aluminum platen brackets a 55088 platen balance spring is required. However, the 74706 spring is still used on units having cast iron platen brackets.
- (D) The 105029 collar is used only when the portion of the hub on the platen extending beyond the line feed ratchet is removed.
- (E) The 135771 screw is used on units equipped with aluminum cross bars. A 6811 screw replaces the 135771 screw on units equipped with cast iron cross bars.

PAGE I-25

- (A) Units equipped with one roller per shaft have four 104473 spacing collars in place of the four end rollers.

The 114657 spring is used in place of a 74708 spring on these units.

- (C) On friction feed units equipped with the ribbon lock-out feature for stencil cutting, a 74371 ribbon carrier should be ordered.

PAGE I-26

- (A) The 117313 paper spindle, for all widths of paper, has replaced all of the old wooden spindles. Wooden spindles are no longer available, however, the 74877 spring used on these spindles is still available for maintenance purposes.

PAGE I-27

- (A) The 89858 pressure roller (long), which is 1/16" longer than the standard 80413 pressure roller, has been designed for use on sprocket feed printers handling forms which have sprocket holes on the left-hand side only of the carbon and on the right-hand side only of the paper.
- (B) The 107174 paper stripper replaces the 80398 pulley and 80399 paper carrier belt. However, the 80398 pulley and 80399 paper carrier belt are still available for maintenance purposes.
- (D) On sprocket feed units equipped with the ribbon lock-out feature for stencil cutting, a 74875 ribbon carrier should be ordered.

PAGE I-31

- (B) The 113703 or 113704 terminal block assembly (series - parallel) replaces the series parallel switch and resistor bracket assembly.

The old style 94490 series-parallel switch assembly, however, is available for maintenance purposes until present stock is exhausted. (See Page III-3).

PAGE I-34

- (A) A 119925 elastic stop nut, replacing the 2191 lock washer and 3598 nut, and a 71047 shim has been added to units equipped with the send-receive-break mechanism operating on "double blank" operation. For "single blank" operation the 71047 shim is not used.

PAGE I-35

- (A) The 90103 set of parts for converting Model 15 printer sets, equipped with spring cushion keytops, to disseminate weather map data consists of the function levers marked (A) (4708 spring used with 84060), 82750 type pallets and 90101 spring cushion keytops listed on pages I-35, I-36, I-39 and I-40, respectively.
- (B) 107160 set of parts to convert to weather map service consists of the function lever marked (B) (4708 spring used with 84060), (1) 74185 pull bar, (1) 7634 pull bar spring, (1) 84734 type bar with pallet (-), 107159 set of type pallets and 92154 set of parts for converting send-receive-break mechanism from single to double blank operation. (See pages I-34, I-35, I-36 and I-37).

PAGE I-43

- (A) The MU3 motor unit includes a 80913 resistor (illustrated on page I-45) for operation at 25 cycles.

PAGE I-47

- (A) The 104572 arm (new style) has replaced the 82411 bracket, 82412 bracket and 82413 arm (old style parts). Old style parts are no longer available.
- (B) The original screws (unslotted #6-32) welded to the cover have been replaced by smaller screws (unslotted #4-36) to provide clearance of slotted mounting bracket. On new style covers the 125235 nuts are used in place of the 83885 nuts formerly used to secure the range finder door and cover door.

PAGE I-51

- (A) In order to maintain the specified clearance between the tabulator stop and the escapement pawl the following changes have been made:

The 86759 tabulator bar has been replaced by a 124033 tabulator bar which has a piece of drill rod soldered in a "V" groove. The 86762 and 86763 tabulator stops have been replaced by 124034 and 124035 tabulator stops also having "V" grooves. New or old style tabulator stops may be used with old style tabulator bar. New style tabulator bar can only be used with new style tabulator stops.

PAGE I-52

- (A) For 1-5/6" long forms a 136394 cam (with 3 notches) replaces the standard 121112 cam. The 136394 cam is not a part of the set of parts and must be ordered separately.

(B) Gears available for use with the 121130 platen indexing mechanism are as follows:

LENGTH OF FORM (INCHES)	GEAR SET NUMBER	PLATEN SHAFT GEAR		IDLER GEAR	
		NUMBER	TEETH	NUMBER	TEETH
1-5/6	* 121221	121184	40	121184	40
2	121214	121174	55	121173	20
2-1/2	121215	121176	44	121175	20
3	121216	121178	44	121177	24
3-2/3	135266	135265	42	121179	28
4	121218	121180	44	121181	32
4-1/2	121219	121182	44	121183	36
5	121220	121182	44	121184	40
5-1/2	121221	121184	40	121184	40
6-1/2	121223	121186	33	121187	39
7	121224	121189	33	121188	42
7-1/3	126993	121189	33	121180	44
7-1/2	121225	121189	33	121190	45
8	121226	121127	33	121191	48
8-1/2	121227	121127	33	121128	51
11	121232	121196	22	121176	44

*136394 cam assembly (with 3 notches) required for the 1-5/6 inch forms.
See paragraph (A) for page I-52.

PAGE I-55

- (A) To facilitate adjustment, the 115790 set of parts also includes two (2) 1169 pressure roller adjusting screws to replace the 1269 pressure roller adjusting screws (illustrated on Page I-25).

PAGE I-56

- (A) The 111017 screw replaces 8543 screw which is used to secure the 74437 slide bar. The 74722 washer is used between the slide bar and platen brackets to lower the ribbon oscillator.

PAGE I-57

- (A) The 129966 hub and 117314 spring have replaced the 120714 hub to permit proper functioning of the paper straightener rod. New and old style parts are interchangeable.

PAGE III-1

- (A) The 110352 set of parts (page I-21) has replaced the 80342 screw, 3606 nut and the 70793 washer. However, the 80342 screw, 3606 nut and 70793 washer are available as maintenance parts for old style units. New and old style parts are not individually interchangeable.
- (B) The 74344 reverse arm (right) and 74345 reverse arm (left) have been replaced by a 93168 reverse arm (right) and 93167 reverse arm (left) (page I-21). The new reverse arms have been designed to prevent the ribbon from falling out by making the opening of the slot for the ribbon at the top instead of the bottom.

NOTE:

A double asterisk (**) following a part or assembly number designates a two-letter suffix which denotes the paint finish. The following finishes are now available:

Black Wrinkle	- AA	Light Brown Wrinkle	- AC
Gray Green Wrinkle	- AB	Dark Brown Wrinkle	- AD

In addition to the colors listed above other colors may be provided on request.

SECTION V

NUMERICAL INDEX

PAGES V-1 THROUGH V-31

Part Number	Description	Page	Part Number	Description	Page
BPC200	Cover	I-47	1169	Screw (6-40 x 7/16 Fil.)...	I-10;IV-4
MU1	Motor Unit	I-43,45	1174	Screw (4-40 Shoulder).....	I-23,54
MU2	Motor Unit	I-43,44,45	1176	Screw (6-40 x 3/16 Fil.)I-2,21,25,67	
MU3	Motor Unit	I-43,45;IV-3	1178	Screw (2-56 x 7/16 Fil.)..I-58,60,68	
MU4	Motor Unit	I-41,45	1179	Screw (6-40 x 5/8 Fil.)...I-41,42,73	
MU5	Motor Unit	I-43,45	1192	Screw (10-32 x 2-9/16 Fil.).....I-64	
MU7	Motor Unit	I-41,45	1196	Screw (6-40 Shoulder).....I-14,17,22	25,65
MU8	Motor Unit	I-41,45	1206	Screw (4-40 x 9/16 Fil.)...I-7,65,72	
MU11	Motor Unit	I-43,44,45	1208	Screw (10-32 x 5/8 Fil.)..I-15,17,18	III-1
MU12	Motor Unit	I-43,45	1210	Screw (2-56 x 5/8 Fil.)..I-52,56;II-2	
MU15	Motor Unit	I-42,45	1222	Screw (2-56 x 1/2 Fil.)..I-8,50,53,73	74;II-1,2
MU27	Motor Unit	I-43,44,45	1224	Stud (6-40 Special).....	I-1
MU28	Motor Unit	I-43,44,45	1226	Screw (6-40 x 3/4 Fil.).....I-5,17,64	65,74;II-1,2
MU32	Motor Unit	I-43,44,45	1245	Screw (10-32 x 1 Fil.)...I-1,6,15,18	IV-1
MU33	Motor Unit	I-42,45	1248	Screw (6-40 x 1/2 Flat Hd.)..I-18,24	70,72
MU35	Motor Unit	I-43,44,45	1266	Screw (6-32 x 7/16 Rd.Hd.).....I-44	
169M	Magnet	I-6	1268	Screw (6-40 x 5/16 Flat Hd.)..I-10,49	
177M	Coil (105 Ohms).....	I-32	1269	Screw (6-40 x 1/2 Fil.)..I-1,13,25,27	58,67;IV-4
195M	Coil (100 Ohms).....	I-8	1275	Screw (10-32 x 1-1/2 Rd.Hd.)....	I-1
196M	Coil (70 Ohms).....	I-7	1291	Screw (6-32 x 3/4 Flat Hd.)....	I-49
198M	Coil (72 Ohms).....	I-70			III-2
207M	Coil (100 Ohms).....	I-29	1294	Screw (4-36 x 1/2 Flat Hd.)....	III-2
217M	Coil (950 Ohms).....	I-7	1297	Screw (6-40 x 2-7/16 Fil.)..I-2,7,10	44,59,64
228M	Coil (72 Ohms).....	I-72	2034	Washer.....	I-50,70
1010	Screw (6-40 Shoulder).....	I-23	2191	Lock Washer...I-1 to 7, 10 to 25,27,	29 to 34,41 to 54,56 to 74;
1020	Screw (6-40 x 1/4 Hex).....	I-16			II-1,2,3;III-1,2,3;IV-3
1026	Screw (6-40 x 3/8 Fil.)..I-5,6,7,18	20,24,59	2199	Nut (7/16-32 Hex).....	I-11
1028	Screw (4-40 x 1/4 Fil.)..I-2,5,6,7	32,45,70	2201	Nut (5/16-32 Hex).....	I-21
1030	Screw (6-40 Shoulder)I-31,32,47,51		2248	Pin.....	I-24
1035	Screw (4-40 x 3/8 Hex).....	I-34,50	2291	Contact Spring.....	I-3
1036	Nut (6-40 Hex).....	I-17	2322	Lock Washer.....	I-18;IV-1
1038	Screw (6-40 x 9/32 Fil.)....	I-7,13	2378	Spacer Key Lever.....	I-10
		19,71	2382	Lock Washer.....	I-14
1041	Screw (6-40 Shoulder)	I-74	2407	Lock Washer.....	I-12,45
1043	Screw (10-32 x 5/16 Rd. Hd.)..	I-59	2422	Lock Washer.....	I-52,63;II-1
1050	Screw (6-40 x 7/32 Fil.)...I-31,32		2438	Washer.....	I-6,32,45,70
1051	Screw (4-40 x 1/2 Fil.).....	I-3,64	2449	Lock Washer...I-6,14,17,22,23,26,28	41,42,43,51
1064	Screw (6-32 x 1/4 Rd. Hd.)....	I-2	2451	Bearing Ball.....	I-22,23
1072	Screw (6-40 Thumb).....	I-47,68	2502	Mounting Plate	I-12
1073	Screw (6-40 Thumb).....	I-31,32,57	2503	Plate.....	I-12
		67	2504	Insulator.....	I-12
1079	Screw (6-32 x 5/16 Fil.).....	I-42	2525	Key Lever Guide-Front.....	I-10
1086	Screw (4-40 x 3/8 Headless)...I-74		2526	Spacing Collar.....	I-12
1095	Screw (4-40 x 5/32 Hex).....	I-69	2528	Spring Plate.....	I-10
1097	Screw (4-40 x 15/32 Fil.)..I-34,56		2529	Bushing.....	I-12
1118	Screw (6-40 Shoulder).....	I-70	2539	Nut (3/8-32 Hex).....	I-14,15,52
1159	Screw (4-40 x 3/8 Fil.).....	I-51	2565	Key Lever Spring	I-10,40
1160	Screw (6-40 x 5/16 Fil.)....	I-1,14	2574	Upstop	I-10
		17,19,20,32,51,57,70	2623	Spring.....	I-12
1161	Screw (6-40 x 1/4 Fil.)....	I-14,19	2663	Bumper-Rubber.....	I-10
		22,24,50,51,62,63,74;II-2			
1162	Screw (4-40 x 1/4 Fil.)..I-7,22,23	25,47,50,56,58,64,68			
1163	Screw (4-40 x 3/16 Fil.)..I-4,22,27	64;II-1;III-3			
1166	Screw (4-36 x 1/4 Flat Hd.)....	I-1			
1168	Screw (4-40 x 5/16 Fil.)..I-3,15,22	23,57,70			

Part Number	Description	Page	Part Number	Description	Page
2666	Nut (3/16-40 Hex).....	I-23	5740	Screw (2-56 x 1/4 Fil).....	I-63
2669	Lock Washer...I-1 to 7,14 to 20,22,23 24,29,34,41,42,43,45,51 52,59,61,65;II-1;III-1,3		5816	Washer-Fiber.....	I-6
2719	Washer.....	I-24	6345	Nut (6-32 Hex).....	I-46,67
2836	Spring.....	I-72	6685	Sword.....	I-30,33
2846	Washer.....	I-41,42,43	6689	Separator Plate.....	I-30,33
2924	Contact Spring.....	I-3	6706	Bracket.....	I-32
2980	Retaining Strap.....	I-5;IV-1	6712	Spring.....	I-68
3106	Turnbuckle.....	I-14	6745	Screw (10-32 x 1/2 Hex)....	I-1,2,3,5,6 7,14,15,19,22,23,34,52,65;II-1;III-3
3110	Nut (10-32 Hex L.H.).....	I-14	6746	Screw (6-40 x 5/16 Hex)..	I-1,6,7,10 to 15,17,18,20,22,23,25,27,29,30 32,33,41,42,43,45,50,52,54 56,63,64,68,70,72;II-3
3131	End Link - Short.....	I-14	6760	Shim (.004").....	I-20
3288	Washer.....	I-21	6799	Screw (6-40 Shoulder).....	I-31,32
3298	Eccentric.....	I-17,32	6800	Screw (6-40 Shoulder)....	I-17,23,24,25 51;IV-1
3339	Nut (9/16-32 Hex).....	I-24	6801	Screw (4-40 Pilot).....	I-31,32
3340	Lock Washer.....	I-24	6805	Screw (6-40 Shoulder).....	I-12,23
3438	Washer...I-2,5,7,10,18,20,47,52,59,70		6807	Screw (6-40 x 3/16 Set).....	I-52,58
3458	Shim (.015").....	I-10	6810	Screw (10-32 x 3/8 Hex)....	I-2,4,14,15 18,34
3571	Bushing.....	I-8,50,53,73,74;II-1	6811	Screw (6-40 x 5/8 Hex)...	I-1,3,4,12,14 16,17,29,32,41,42,43,50,52 60,61,64,65,68,71,72,74;II-1,2;IV-2
3595	Nut (1/4-32 Hex)...I-6,14,17,26,28,51		6814	Screw (6-40 Pilot).....	I-12,50
3598	Nut (6-40 Hex)....I-1,10,12,14,17,18 19,22 to 25,27,29 to 34,44,46 47,49 to 52,54,57,60,61,63 65,67,69,70,71,72;II-1;III-1,2;IV-3		6827	Connection Block.....	I-2
3599	Nut (4-40 Hex)...I-3,7,10,11,22,23,25 27,29,34,44,50,51,52,54 56,60,62,63,64,68,70;III-3		6830	Trip Latch.....	I-32
3603	Nut (1/4-32 Hex).....	I-14,19	6836	Yoke.....	I-32
3606	Nut (6-40 Hex)..I-7,10,19,23,29,49,52 58,63,64,68;II-1;III-1,2;IV-4		6850	Bell Crank.....	I-32
3610	Spring.....	I-54	6859	Spacing Collar.....	I-19
3618	Insulator.I-6,8,50,53,56,73,74;II-1,2		6863	Cam Sleeve Disk.....	I-16
3624	Washer.....	I-68	6884	Bracket.....	I-32
3640	Lock Washer.....I-2,3,6,7,11,12,15,17 22 to 25,27,31,32,34,44 to 48 50 to 56,58,60,62,64,66,68,69,70 72,73;II-1;III-2,3		6909	Stop Pawl.....	I-31,32
3646	Lock Washer.I-2,6,7,10,24,59,64,70,72		6940	Spring Post.....	I-20,23
3647	Insulator...I-6,8,50,53,56,73,74;II-2		6942	Screw (4-40 Eccentric).....	I-12,32
3649	Washer.....	I-18	6966	Screw (4-40 Eccentric).....	I-31,32
3650	Washer-Brass.....	I-5,6,7	6970	Nut (3/8-32 Hex).....	I-24
3870	Spring.....	I-7	6971	Clutch Throw-Out Lever.....	I-30,33
3897	Bushing.....	I-4,58,66	6987	Washer.....	I-19,60
3899	Collar.....	I-6	6990	Screw (1/4-32 Pilot).....	I-30,33
3949	Spacer.....	I-53,73	6993	Spring.....	I-16
4293	Insulator.....	I-3,4,58,66	7001	Washer.....	I-19,30,33
4323	Ball.....	I-16	7002	Washer.....I-1,4,6,7,10 to 13,17,19 to 25,27,29,31,32,34,41 to 47 51 to 54,56 to 74;II-1,2,3;III-3	
4703	Spring.....	I-23	7007	Trip Plunger.....	I-31,32
4708	Spring.....	I-29,35;IV-3	7022	Reverse Lever-Left.....	I-23
4730	Spring.....	I-69	7023	Reverse Lever-Right.....	I-23
4810	Wick.....	I-11	7024	Reverse Pawl-Left.....	I-23
4812	Wick.....	I-19	7025	Reverse Pawl-Right.....	I-23
4814	Lock Washer.....	I-1,21,26,28	7032	Pawl.....	I-12
4851	Terminal.....	I-32,59,72	7036	Collar.....	I-25,27
4852	Lock Washer.....	I-18,69	7044	Link.....	I-23
4871	Bolt (10-24 x 4 Rd.Hd.).....	I-6,45	7093	Terminal Block.....	I-4
4881	Stiffener.....	I-12	7094	Connection Spring....	I-1,4,60,64,65,68 71,72,74;II-1,2
5017	Spring.....	I-7	7095	Retainer Plate....	I-1,4,60,64,65,68,71 72,74;II-1,2
5446	Screw (6-40 x 9/16 Fil).....	I-18	7096	Bushing.....	I-3,4
5475	Nut (3/16-40 Hex).....	I-29			

Part Number	Description	Page	Part Number	Description	Page
7105	Target-10 Spot.....	I-41,43	8896	Shim (.004").....	I-7,12,17,19,21,70
7318	Contact Lever.....	I-12	9177	Contact Spring.....	I-12
7334	Post.....	I-10	9178	Contact Spring.....	I-12
7339	Cam Sleeve (7.00).....	I-11	9182	Shaft.....	I-12
7372	Bearing.....	I-11	9203	Bracket (with Rollers).....	I-10
7373	Bearing Bushing.....	I-12	9209	Key Lever (with Disk).....	I-10
7377	Lock Loop.....	I-12	9210	Key Lever (with Disk).....	I-10
7381	Contact Mounting Assembly.....	I-12	9695	Plunger.....	I-6
7382	Bracket - Front.....	I-12	21397	Spring Washer.....	I-34
7383	Nut.....	I-12	22015	Spring.....	I-74
7385	Bracket (with Posts) - Rear.....	I-12	31636	Spring.....	I-54
7386	Stud.....	I-12	33038	Spring.....	I-63
7387	Brace.....	I-12	34432	Washer.....	I-3,4,15,17,18,19,22 23,25,31,32,34;III-1,3
7389	Driving Clutch.....	I-11	34444	Spacing Collar.....	I-69
7391	Driven Clutch.....	I-11	34464	Spring.....	I-35,71
7396	Bracket - Left.....	I-10	35503	Foot-Rubber.....	I-1
7397	Bracket - Right.....	I-10	35826	Washer.....	I-14
7398	Retainer Plate.....	I-3,4,58,66	35858	Margin Bell.....	I-15
7399	Stiffener.....	I-3,4,58,66	36273	Washer.....	I-11,12,23,44,69
7409	Clutch Lever.....	I-12	41177	Screw (8-40 x 9/64 Fil.).....	I-24
7482	Key Lever.....	I-10	41181	Knob.....	I-24
7602	Spring.....	I-31,32	41341	Crank Handle.....	I-24
7603	Spring.....	I-31,32,71	41342	Screw (8-40 Shoulder).....	I-24
7607	Collar.....	I-31,32	41543	Ball Bearing.....	I-18
7612	Spring.....	I-32	41663	Washer.....	I-12
7614	Spring.....	I-30,33	41675	Washer.....	I-21,23,25
7615	Spring.....	I-30,33	41720	Contact Spring.....	I-66;III-3
7634	Spring.....	I-22,23,36,69;II-2,3;IV-3	41732	Retainer Plate.....	I-3,7,58,62,64,65,71 72;II-1,2;III-3
7654	Shim (.004").....	I-60	41733	Insulator.....	I-3,58,62,64,66,71,72 II-1,2;III-3
7661	Adjusting Lever.....	I-43	41746	Bushing.....	I-66;II-1
7678	Screw (4-40 Pilot).....	I-24,52	41820	Contact Spring.....	I-71
7679	Roller.....	I-24	41830	Contact Spring.....	III-3
7835	Ribbon - Black.....	I-21	42823	Washer.....	I-55
7959	Magnet Bracket.....	I-6	43838	Cotter Pin.....	I-7
7965	Spring.....	I-51	43954	Bell.....	I-18
8097	Cam Sleeve (7.42).....	I-11	44048	Washer.....	I-46,64
8157	Selector Lever - Right.....	I-30,33	45104	Spring.....	I-25,70
8158	Selector Lever - Left.....	I-30,33	45333	Screw (8-40 x 7/16 Hex).....	I-6
8184	Washer.....	I-24	46092	Nut (10-32 Hex).....	I-14
8222	Wearing Strip.....	I-43	49385B	Insulator.....	II-1
8254	Cable Clamp.....	I-4	49396B	Washer.....	I-61
8308	Cable Clamp.....	I-4,70	55063	Spring.....	I-25
8330	Washer.....	I-22,43,70,71	55080	Bezel.....	I-10
8472	Locking Wedge.....	I-32	55088	Spring.....	I-17,24;IV-2
8486	Spring Post.....	IV-1	70177	Screw (6-40 Pilot).....	I-10
8507	Cam Sleeve (Stamped "CX").....	I-33	70324	Bearing.....	I-11
8508	Armature.....	I-32	70464	Nut (8-40 Hex).....	I-70
8511	Locking Lever.....	I-33	70470	Locking Bar.....	I-13
8514	Stop Plate.....	III-2	70529	Stiffener.....	I-3,64,71;II-1,2
8539	Screw (6-40 x 1/2 Hex).....	I-1,2,4,6,7,10 11,16,17,19,21,22,24,25,27,32 46,52,58,65,66,69,72;III-3	70593	Screw (6-40 Thumb).....	I-15
8543	Screw (6-40 x 1/4 Fil).....	I-25,27,49,58 59,73;IV-4	70707	Bracket.....	I-6,45
8671	Screw (6-40 Shoulder).....	I-50	70724	Insulator.....	I-6,45
8783	Locking Lever.....	I-11	70793	Washer.....	III-1;IV-4
8809	Power Cord.....	I-9	70803	Screw (6-40 Pivot).....	I-32
8811	Line Cord.....	I-9	70873	Brush Holder Cap.....	I-44
8884	Terminal Block.....	I-17,41,42,43,60,64 65,68,71,72,74;II-1,2,4	70884	Eccentric.....	I-13
			70885	Spring Washer.....	I-13

Part Number	Description	Page	Part Number	Description	Page
70886	Washer.....	I-13,17,51	72818	Relay.....	I-6
70887	Nut (10-24 Hex).....	I-6,45	72824	Celluloid Keytop.....	I-40
70892	Lock Nut (1/8-27 Hex).....	I-45	72825	Celluloid Keytop.....	I-40
70893	Nipple	I-45	72826	Celluloid Keytop.....	I-39
71045	Lock Nut (6-40 Special).....	I-32	72827	Celluloid Keytop.....	I-39
71046	Screw (6-40 Special).....	I-32	72828	Celluloid Keytop.....	I-40
71047	Shim (.010").....	I-6,34;IV-3	72830	Celluloid Keytop.....	I-40
71051	Buzzer.....	I-65	72983	Key Lever.....	I-10
71073	Washer.....	I-29,32,52,60,63	72984	Key Lever.....	I-10
71161	Bushing.....	I-11	73151	Celluloid Keytop.....	I-40
71444	Bushing.....	I-58	73152	Celluloid Keytop.....	I-40
71445	Link	I-32	73175	Lock Washer.....	I-14,15,52
71449	Key Lever Guide-Rear.....	I-10	73196	Resistor (200-400 Ohms)(W.E.Co. 19-BB).....	I-1
71505	Wick.....	I-16	73197	Resistor (300-500 Ohms)(W.E.Co. 19-GJ).....	I-1
71659	Screw (6-40 Shoulder).....	I-15,57,70	73276	Screw (6-40 Shoulder)....	I-18,60,63 64,65,71
71670	Mounting Block.....	I-1	73427	Shim (.014").....	I-22
71671	Jack Spring-Left.....	I-1	73497	Plug - Red.....	I-9
71672	Cable Clamp.....	I-1	73588	Contact Spring	I-6,8,50,53 56,73,74;II-2
71675	Jack Spring-Right.....	I-1	73592	Spring Plate.....	I-6
71681	Printing Ribbon Spool	I-21	73593	Contact Spring	I-6,8,50,53,56 73,74;II-2
71696	Range Scale.....	I-32	73641	Line Guide.....	III-2
71697	Clamping Plate.....	I-31,32	73670	Terminal Block Assembly....	I-5,6,7 IV-1
71829	Range Scale Assembly.....	I-32	73705	Terminal Block	I-5,6,7
71976	Stop Pawl Plate.....	I-31,32	73844	Washer	I-7
72021	Resistor Mounting Block Assembly..	I-1	74001	Shaft	I-11
72031	Celluloid Keytops.....	I-39	74003	Selector Mounting Plate	I-32,33
through 72035	Celluloid Keytop.....	I-40	74005	Shaft.....	I-20
72036	Celluloid Keytop.....	I-40	74006	Bushing.....	I-23
72037	Celluloid Keytops.....	I-39	74008	Bail Roller.....	I-23
through 72039	Celluloid Keytops.....	I-39	74009	Pawl Latch.....	I-50
72041	Celluloid Keytops.....	I-40	74010	Roller.....	I-22
through 72059	Celluloid Keytop.....	I-40	74011	Screw (6-40 Shoulder)....	I-14,24,69
72061	Resistor (1000 Ohms).....	I-6	74013	Printing Bail Blade.....	I-19
72064	Washer.....	I-72	74014	Screw (10-32 x 3/4 Hex)..	I-1,2,4,20 46
72254	Cable	I-65	74015	Spring.....	I-19
72425	Shim (.004").....	I-11	74016	Post.....	I-14,15
72472	Receptacle.....	I-53	74017	Screw (6-40 Shoulder).....	I-17
72480	Plug.....	I-9	74018	Plunger Rod.....	I-14
72481	Relay.....	I-6	74019	Spring Plate.....	I-20
72501	Shaft.....	I-11	74020	Screw (6-40 Shoulder).....	I-24
72508	Screw (6-40 x 3/4 Hex).....	I-3,60,68 71,72	74021	Bell Crank (No.1).....	I-19
72509	Lock Washer.....	I-18,25,42	74022	Bell Crank (No.2).....	I-19
72513	Driving Disk.....	I-16	74023	Bell Crank (No.3).....	I-19
72514	Spring.....	I-16	74024	Bell Crank (No.4).....	I-19
72515	Keyed Nut.....	IV-1	74025	Bell Crank (No.5).....	IV-1
72516	Retaining Disk.....	I-33	74026	Collar.....	I-17
72517	Keyed Nut (5/16-32).....	IV-1	74027	Screw (1/4-32 Pivot).....	I-14
72521	Wick.....	I-16	74028	Dashpot Cylinder.....	I-14
72545	Post.....	I-10	74029	Washer.....	I-14
72562	Driving Clutch.....	I-16	74031	Platen Bracket-Right.....	I-24
72563	Washer-Felt.....	I-16	74032	Washer.....	I-14
72566	Resistor (100-100 Ohms).....	I-44	74033	Washer-Leather.....	I-14
72635	Shim (.002").....	I-70	74036	Nut (10-32 Hex).....	I-22,23
72643	Screw (6-40 Shoulder).....	I-10			
72644	Ball Bearing.....	I-16			

Part Number	Description	Page	Part Number	Description	Page
74037	Motor Stop Lever.....	I-50	74132	Spacing Gear.....	I-16
74038	Function Lever.....	I-35,50;II-3	74133	"T" Lever.....	I-30,33
74039	Function Lever.....	I-34,35	74134	"T" Lever.....	I-30,33
74040	Function Lever.....	I-35	74135	"T" Lever.....	I-30,33
74041	Type Basket.....	I-23;I7-2	74136	"T" Lever.....	I-30,33
74042	Selector Vane (No. 1).....	I-20	74137	"T" Lever.....	I-30,33
74043	Selector Vane (No. 2).....	I-20	74138	Function Lever.....	I-35
74044	Selector Vane (No. 3).....	I-20	74140	Printing and Function Cam.....	I-16
74045	Selector Vane (No. 4).....	I-20	74142	Cylinder Head.....	I-14
74046	Selector Vane (No. 5).....	I-20	74143	Retainer Plate.....	I-18
74049	Screw (4-40 Shoulder).....	I-50	74148	Bell Hammer.....	I-17
74050	Margin Bell Cam.....	I-15	74150	Bell Operating Lever.....	I-17
74051	Lever.....	I-15	74151	Gear (35T).....	I-41
74052	Keyboard Track.....	III-1	74152	Spring.....	I-16
74053	Connector Assembly.....	I-4	74153	Ball Bearing.....	I-16
74056	Retaining Plate.....	I-25	74154	Spacing Gear - Lower.....	I-18
74058	Detent Lever.....	I-14	74156	Screw (10-32 Special).....	I-19
74059	Screw (6-40 x 7/32 Hex).....	I-1,25,34,44 46,58;III-3	74158	Function Bail Blade.....	I-19
74061	Clutch Disk.....	I-16	74160	Carriage Return Lock Bar.....	I-17
74062	Track - Lower.....	I-15	74161	Lock Bar Latch.....	I-17
74063	Spiral Gear (24T).....	I-16	74162	Extension Arm.....	I-17
74064	Gear (26T).....	I-11	74163	Shift Push Bar.....	I-17
74066	Shift Link Bracket.....	I-17	74164	Spacing Shaft.....	I-18
74068	Latch Bar.....	I-17	74166	Driving Disk.....	I-16
74069	Reset Bar.....	I-17	74169	Clamp.....	I-20
74071	Clutch Fork.....	I-17	74170	Screw (10-32 Pivot).....	I-20
74072	Operating Lever.....	I-17	74171	Screw (6-40 Eccentric).....	I-17
74076	Screw (1/4-32 Shoulder).....	I-14	74172	Screw (10-32 Eccentric).....	I-14
74077	Screw (10-32 Shoulder).....	I-14,17	74173	Bell Latch Bar.....	I-17
74078	Latch Link.....	I-17	74174	Bell Push Bar.....	I-17
74079	Line Feed Bail.....	I-14	74175	Bracket.....	I-50
74080	Shift Link.....	I-17	74178	Bracket.....	I-15
74081	Line Feed Push Bar.....	I-14	74179	Shaft.....	I-21
74082	Shift Lever.....	I-14	74180	Code Bar.....	I-19,36
74083	Vertical Link.....	I-14	74181	Code Bar.....	I-19,36
74089	Printing Bail Arm.....	I-19	74182	Code Bar.....	I-19,36
74091	Motor Plate.....	I-41,42,43	74183	Code Bar.....	I-19,36
74095	Spacing Collar.....	I-19	74184	Code Bar.....	IV-1
74096	Spacing Pawl - Front.....	I-19	74185	Pull Bar.....	I-36,69;II-2,3;IV-3
74097	Spacing Pawl.....	I-19,51	74186	Disk.....	I-25
74098	Shaft.....	I-19	74187	Pull Bar Guide.....	I-19,23
74099	Retaining Ring.....	I-16	74190	Spacing Clutch.....	I-18
74100	Washer - Leather.....	I-16	74191	Latch.....	I-20
74101	Oil Plug.....	I-16	74192	Spacing Gear - Upper.....	I-18
74107	Bearing.....	I-19	74194	Stud.....	I-22
74109	Function Lever.....	I-34,35	74195	Bearing Roller.....	I-22
74110	Stud.....	I-17	74196	Stud.....	I-23
74111	Shaft.....	I-14	74197	Bail Roller.....	I-23
74112	Screw (10-32 Pilot).....	I-17	74198	Bearing Cone.....	I-23
74119	Bail Shaft Bearing.....	I-14	74199	Eccentric Bushing.....	I-19;IV-1
74121	Latch Bell Crank.....	I-17	74200	Track - Upper.....	I-15
74122	Screw (6-40 x 13/16 Hex).....	I-19	74202	Type Bar #2 (without Pallet).....	I-37,38
74124	Cross Bar Assembly.....	I-18	74202A	Type Bar #2 (with Pallet).....	I-38
74126	Support.....	I-15	74203	Type Bar #3 (without Pallet).....	I-37,38
74127	Function Lever.....	I-35	74203A	Type Bars #3 (with Pallets).....	I-38
74128	Function Lever.....	I-35	through		
74129	Function Lever.....	I-35	74203C		
74130	Function Lever.....	I-35	74204	Type Bar #4 (without Pallet).....	I-37,38
74131	Function Lever.....	I-35	74205	Type Bar #5 (without Pallet).....	I-36,38

Part Number	Description	Page	Part Number	Description	Page
74205A through 74205E	Type Bars #5 (with Pallets)....	I-38	74247	Shift Stop Post.....	I-24
74206	Type Bar #6(without Pallet).....	I-37, 38	74248	Stud.....	I-24
74207	Type Bar #7(without Pallet)....	I-37	74249	Screw (1/4-32 Pilot).....	I-14
74208	Type Bar #8(without Pallet).....	I-37, 38	74251	Dashpot Lever.....	I-14
74209	Type Bar #9(without Pallet)....	I-37	74252	Screw (3/8-32 Pilot).....	I-14, 15
74210	Type Bar #10(without Pallet).....	I-37, 38	74253	Stud.....	I-23
74210A	Type Bar #10 (with Pallet).....	I-38	74254	Cross Bar - Rear.....	I-17
74211	Type Bar #11(without Pallet).....	I-37, 38	74255	Function Lever Comb.....	I-20, 54
74211A through 74211C	Type Bars #11 (with Pallets)....	I-38	74259	Detent.....	I-24
74212	Type Bar #12(without Pallet)....	I-37	74262	Arm - Left.....	I-57
74213	Type Bar #13(without Pallet)....	I-37	74263	Arm - Right.....	I-57
74214	Type Bar #14(without Pallet).....	I-37, 38	74264	Platen Shaft.....	I-24; IV-2
74214A through 74214F	Type Bars #14 (with Pallets)....	I-38	74269	Washer.....	I-18
74215	Type Bar #15(without Pallet)....	I-36	74271	Clamping Washer.....	I-18
74216	Type Bar #16(without Pallet)....	I-37	74272	Spring.....	I-18
74217	Type Bar #17(without Pallet).....	I-36, 38	74275	Shaft.....	I-18
74218	Type Bar #18(without Pallet).....	I-37, 38	74276	Ball Bearing.....	I-18
74218A through 74218D	Type Bars #18 (with Pallets)....	I-38	74278	Escapement Lever.....	I-18
74219	Type Bar #19(without Pallet)....	I-37	74279	Strip - Leather.....	III-3
74220	Type Bar #20(without Pallet).....	I-36, 38	74281	Backstop Assembly.....	III-3
74220A through 74220D	Type Bars #20 (with Pallets)....	I-38	74282	Dashpot Assembly.....	I-14
74221	Type Bar #21(without Pallet).....	I-36, 38	74283	Spring Washer.....	I-25, 34, 74
74221A through 74221G	Type Bars #21 (with Pallets)....	I-38	74286	Bail Guide.....	I-19
74221H	Type Bar #21 (with Pallet)....	I-36	74289	Backstop.....	I-50
74222	Type Bar #22 (without Pallet).....	I-36, 37, 38	74291	Spring Bracket.....	I-50
74222A through 74222F	Type Bars #22 (with Pallets)....	I-38	74292	Screw (10-32 Shoulder).....	I-23
74223	Type Bar #23(without Pallet)....	I-37	74294	Adapter Plate.....	I-22
74224	Type Bar #24(without Pallet).....	I-37, 38	74296	Screw (6-40 Pilot).....	I-22
74224A through 74224D	Type Bars #24 (with Pallets)....	I-38	74297	Latch Plate.....	I-17
74225	Type Bar #25(without Pallet).....	I-37, 38	74300	Spring Drum Assembly.....	I-18
74225A through 74225E	Type Bars #25 (with Pallets)....	I-38	74301	Set of Type Pallets-Murray Style...	I-36
74226	Type Bar #26(without Pallet)....	I-37	74302 through 74304	Type Pallets.....	I-37
74227	Type Bar #27(without Pallet).....	I-37, 38	74305	Type Pallet.....	I-36
74228	Type Bar #28(without Pallet).....	I-37, 38	74306 through 74313	Type Pallets.....	I-37
74228A	Type Bar #28(with Pallet).....	I-38	74314	Type Pallet.....	I-37, 38
74230	Driving Clutch.....	I-18	74315	Type Pallet.....	I-36
74239	Clutch Bushing.....	I-16	74316	Type Pallet.....	I-37
74240	Roller.....	I-23	74317	Type Pallet.....	I-36
74241	Driven Clutch.....	I-18	74318	Type Pallet.....	I-37; II-2, 3
74243	Roller Assembly.....	I-23	74319	Type Pallet.....	I-37
74244	Printing Bail.....	I-19; IV-1	74320 through 74322	Type Pallets.....	I-36
74246	Motor Stop Pawl-Inner.....	I-50	74323 through 74328	Type Pallets.....	I-37
			74329	Shaft.....	I-21
			74330	Spring.....	I-22
			74331	Spring.....	I-22
			74332	Flanged Roller.....	I-23
			74334	Washer.....	I-23
			74335	Shaft Lever.....	I-22
			74337	Roller - Upper.....	I-23
			74338	Release Lever.....	I-25
			74339	Cross Bar.....	I-25
			74342	Eccentric Stud.....	I-23

Part Number	Description	Page	Part Number	Description	Page
74343	Stud.....	I-23	74451	Release Lever Shaft.....	I-25
74344	Reverse Arm - Right.....	III-1;IV-4	74452	Release Shaft.....	I-25
74345	Reverse Arm - Left.....	III-1;IV-4	74454	Release Cam.....	I-25
74358	Bracket.....	I-15	74455	Paper Chute.....	I-25
74359	Draw Strap.....	I-18	74457	Guide Lever.....	I-25
74361	Screw (6-40 Shoulder).....	I-24	74460	Shaft.....	I-25,56
74363	Pull Bar Bail.....	I-23	74463	Adjusting Lever.....	I-25
74366	Spacing Rack.....	I-22	74465	Line Feed Lever.....	I-24
74367	Screw (10-32 Special).....	I-26,28	74467	Line Feed Pawl.....	I-24
74368	Bail Roller Assembly.....	I-23	74469	Paper Finger - Right.....	I-25
74371	Ribbon Carrier.....	IV-2	74470	Paper Finger - Left.....	I-25
74372	Link.....	I-23	74473	Stop.....	I-25
74373	Type Bar Segment.....	I-22	74476	Straightener Rod.....	I-25
74374	Plunger.....	I-23	74477	Tearing Edge.....	I-57
74376	Bracket.....	I-23	74478	Lever.....	I-24
74378	Margin Bell Pawl.....	I-22	74479	Bushing.....	I-24
74379	Bracket.....	I-22	74480	Spring.....	I-24
74380	Shaft.....	I-23	74481	Detent Roller.....	I-24
74381	Feed Pawl.....	I-23	74482	Guide Plate.....	I-49
74383	Bearing - Right.....	I-23	74490	Roller - Front.....	I-25,56
74384	Gear.....	I-21	74491	Roller - Rear.....	I-25
74385	Gear.....	I-21	74493	Spacer.....	I-25,56
74390	Ribbon Reverse Bail.....	I-23	74494	Spacer.....	I-25,56
74392	Spool Bracket.....	I-21	74495	Guide Block.....	I-49
74394	Shaft.....	I-21	74499	Bearing Cap - Right.....	I-23
74395	Relay Guard.....	I-2	74500	Bearing - Left.....	I-23
74397	Draw Strap Post.....	I-22	74501	Bearing Cap - Left.....	I-23
74398	Shaft.....	I-23	74502	Driven Clutch.....	I-16
74399	Screw (6-40 Pilot).....	I-30,33	74503	Function Bail.....	I-19
74401	Ribbon Oscillator.....	I-22	74505	Pinion (7T).....	I-41
74404	Operating Lever.....	III-3	74507	Lever.....	I-34
74405	Bracket.....	III-3	74508	Spring Housing.....	I-18
74406	Contact Lever.....	III-3	74511	Spring.....	I-23
74407	Send-Receive-Reset Lever.....	I-34	74512	Roller Assembly.....	I-22
74408	Post.....	I-34	74513	Fulcrum Rod.....	I-22
74409	Contact Lever.....	I-50	74514	Screw (4-40 x 55/64 Fil.).....	III-3
74410	Frame - Left.....	I-14	74519	Paper Finger Shaft.....	I-25
74411	Send-Receive Handle.....	III-3	74520	Screw (6-40 Eccentric).....	I-34
74412	Bushing.....	I-17	74521	Bevel Gear.....	I-21
74413	Backstop.....	I-17	74525	Screw (1/4-32 Thumb).....	I-10
74414	Type Bar Guide.....	I-22	74526	Locking Collar.....	I-21
74415	Guide Bracket.....	I-34	74528	Spacer Bar Loop.....	I-10
74416	Lever.....	I-34	74529	Bracket.....	I-13
74417	Lever.....	I-34	74530	Separator.....	I-1
74420	Bracket.....	I-1,5	74531	Switch Cover.....	I-1
74421	Bracket.....	I-45	74533	Latch Handle.....	III-3
74422	Bracket.....	I-1,2	74534	Bearing Bracket.....	I-17
74424	Bracket.....	I-6	74536	Screw (6-40 x 9/64 Fil.)..	I-21,24,25 27,60
74425	Receptacle.....	I-1	74537	Safety Pawl.....	III-3
74428	Send-Receive-Break Mechanism...	III-3	74538	Bracket.....	I-50,74;II-2
74430	Bracket.....	I-1,5,6;IV-1	74539	Mounting Plate.....	I-34
74432	Mounting Plate.....	I-4	74545	Release Lever.....	I-50
74433	Plate Insulator.....	I-4	74546	Cable Clamp.....	I-4
74435	Platen Bracket - Left.....	I-24	74548	Spring.....	I-18
74437	Slide Bar.....	I-25;IV-4	74551	Insulator.....	I-1
74438	Platen - Rubber Covered.....	I-26	74552	Frame.....	I-20
74446	Line Feed Ratchet.....	I-24;IV-2	74554	Spring Post.....	I-25,30,33
74447	Detent Ratchet.....	I-24;IV-2	74556	Motor Stop Pawl.....	I-50
74448	Bushing.....	I-24	74557	Lamp.....	I-45
74449	Bushing.....	I-24			

Part Number	Description	Page	Part Number	Description	Page
74558	Socket.....	I-45	74663		
74559	Shaft.....	I-24	through	Type Bars (with Pallets).....	I-37
74561	Post.....	I-24	74668		
74562	Screw (6-40 Special).....	I-24	74670	Strap.....	I-3
74563	Lever.....	I-24	74684	Contact Spring.....	I-4
74564	Detent Lever	I-24	74685	Contact Spring.....	I-4,58,66
74566	Screw (10-32 Shoulder).....	I-24	74686	Shift Vane.....	I-20
74567	Screw (1/4-20 x 1/2 Hex).....	I-41,42,43	74687	Screw (6-40 x 5/8 Fil.).....	I-23
74568	Terminal Block.....	I-1	74688	Lever.....	I-34
74569	Terminal Block.....	I-10	74689	Guide Post.....	I-19
74571	Cable Assembly.....	I-45	74690	Transmitter Mechanism.....	I-12
74572	Cable.....	II-4	74691	Resistor.....	I-10
74573	Cable.....	II-4	74692	Post Spring.....	I-14,17,51,63,64
74574	Cable.....	II-4	74693	Post.....	I-24
74575	Cable.....	I-2;II-4	74694	Friction Arm.....	I-24
74581	Selector Bar.....	I-10	74695	Friction Sleeve.....	I-24
74582	Selector Bar.....	I-10	74697	Copyholder Extension.....	I-49
74583	Selector Bar.....	I-10	74700	Spring.....	I-22
74584	Selector Bar.....	I-10	74701	Spring.....	I-51;III-3
74585	Selector Bar.....	I-10	74702	Spring.....	III-3
74587	Base Pad.....	I-1	74703	Spring.....	I-50
74588	Terminal Block Assembly.....	I-1	74704	Spring.....	I-14
74589	Terminal Block.....	I-10	74705	Spring.....	I-34,35,51,54
74590	Plate.....	I-10	74706	Spring.....	I-24;IV-2
74592	Retaining Rod.....	I-1	74707	Spring.....	I-14,51
74594	Retaining Ring.....	I-10	74708	Spring.....	I-25;IV-2
74595	Gear (24T).....	I-11	74709	Spring.....	I-25,52
74596	Spiral Gear.....	I-16	74710	Spring.....	I-24
74599	Eccentric.....	I-50	74712	Spring.....	I-14;II-1
74601	Universal Bar.....	I-10	74716	Bushing.....	III-3
74604	Repeat Space Rod.....	I-11	74717	Screw (4-40 x 23/32 Fil.).....	I-64,66 III-3
74605	Bracket.....	I-11	74718	Bushing.....	III-3
74609	Spacer Bar Shaft.....	I-10	74719	Relay Base.....	I-2;IV-1
74610	Key Lever Shaft.....	I-10	74720	Screw (1/4-20 Thumb).....	I-1;IV-1
74613	Screw (4-40 x 1/4 Hex)	I-25,55,56	74721	Spring.....	I-23
74614	Resistor.....	I-2,46	74722	Washer.....	I-19,51,56,69;IV-4
74620	Switch.....	I-1	74724	Screw (10-32 Thumb).....	I-32
74621	Stud Assembly.....	I-1	74725	Screw (6-40 Shoulder).....	I-17
74624	Blank Guide Assembly.....	I-49	74726	Extension.....	I-22
74625	Cable.....	I-32;II-4	74727	Terminal.....	I-3,62,64,66;III-3
74627	Connector Assembly.....	I-4	74728	Terminal.....	I-65;II-1,2;III-3
74628	Fuse Holder.....	I-1	74730	Screw (6-40 Shoulder).....	I-22
74635	Mounting Strap.....	I-62	74731	Nut (6-40 Hex).....	I-22
74637	Spring.....	I-47,48	74732	Post.....	I-25
74638	Glass.....	I-61	74733	Stud.....	I-18,25
74642	Type Bar (with Pallet).....	I-37;II-2,3	74736	Bracket.....	I-18
74643	Type Bar (with Pallet).....	I-37	74737	Lever.....	I-18
74644	Type Bar (with Pallet).....	I-37	74739	Screw (6-40 Special).....	I-26,28
74645	Type Bar (with Pallet).....	I-36	74744	Guard.....	I-3
74646			74749	Stop Plate.....	I-10
through	Type Bars (with Pallets).....	I-37	74751	Trip-off Pawl.....	I-12
74654			74754	Detent Spring.....	I-23
74655	Type Bar (with Pallet).....	I-36	74755	Wick.....	I-16
74656	Type Bar (with Pallet).....	I-37	74756	Wick.....	I-16
74657	Type Bar (with Pallet).....	I-36	74757	Bracket.....	I-44
74658	Type Bar (with Pallet).....	I-37	74759	Felt.....	I-47,68
74659	Type Bar (with Pallet).....	I-37	74760	Spring.....	I-19,66
74660			74762	Key Lever.....	I-10,40
through	Type Bars (with Pallets).....	I-36	74763	Set of Type Pallets-Murray Style Fractions.....	I-36
74662					

Part Number	Description	Page	Part Number	Description	Page
74764	Set of Parts for Mechanical Motor Control.....	I-50	74898	Locating Stud.....	I-1
74765	Type Pallet.....	I-37;II-2,3	74899	Ball Bearing.....	I-16
74766	Type Pallet.....	I-37	74900	Washer.....	I-16
74767	Type Pallet.....	I-36	74901	Nut (15/32-32 Hex).....	I-16
74768	Type Pallet.....	I-37	74904	Shaft.....	I-16
74769	Type Pallet.....	I-37	74909	Frame-Right.....	I-15
74770	Type Pallet.....	I-36	74912	Pinion (7T).....	I-41
74771	Type Pallet.....	I-36	74913	Gear (30T).....	I-41
74772	Type Pallet.....	I-37	74916	Gear Hub.....	I-16
74773	Set of Type Pallets Murray Style.....	I-36	74923	Screw Assembly.....	I-26,28
74776	Insulator.....	I-1	74928	Spring Post.....	I-25
74783	Lever.....	I-20	74932	Function Lever.....	I-35
74788	Cable.....	I-45	74933	Pull Bar Stripper.....	I-19
74789	Cable.....	I-50;II-4	74946	Insulator.....	I-17,60,64,65,68,71 72,74;II-1,2
74790	Cable Clamp.....	I-4	74949	Lever.....	I-3
74793	Line Guide.....	I-49;III-2	74952	Screw (4-40 x 5/8 Fil.)....	I-3,58,62 71;II-1
74795	Stop Plate.....	III-2	74953	Screw (4-40 x 13/16 Fil.)....	I-8
74798	Screw (6-40 x 31/64 Fil.)....	I-18	74961	Spring.....	I-35
74799	Retainer Plate.....	I-18	74962	Spring.....	I-35,53,73,74;II-1,2
74801	Disk.....	I-16	74964	Contact Spring.....	I-3,64
74802	Spring.....	I-16	74969	Sleeve Bearing.....	I-21
74805	Screw (10-32 x 3/4 Hex)....	I-16,19,23	74972	Stud.....	I-23
74806	Guide Post Mounting Plate....	I-23	74975	Screw (10-32 x 5/8 Fil.)....	I-1
74807	Nut (10-32 Hex).....	I-23	74986	Screw (6-40 x 13/32 Hex)...	I-4,10,14 16,19,22,27,51,53,61,69,70,73
74808	Bushing.....	I-11	74988	Spring.....	I-50
74813	Set of Parts for Platen Tearing Edge.....	I-57	74990	Insulator.....	I-1
74814	Relay Mounting Assembly....	I-6;IV-1	74991	Insulator.....	I-41,42,43
74816	Lever Assembly.....	I-34	74992	Insulator Bushing.....	I-5,6
74817	Line Relay Spark Protection....	I-3	74994	Mounting Plate.....	I-19
74820	Platen-Hard Rubber.....	I-26	74995	Bell Crank.....	I-19
74821	Resistor.....	I-2	75229	Spring.....	I-3
74825	Covering Strip.....	I-47	75231	Bushing.....	I-2,6
74838	Bearing Cap.....	I-14	75249	Bushing.....	I-74
74839	Motor Unit.....	II-3	75257	Spring Post.....	I-24
74840	Motor Unit.....	II-3	75400	Screw (6-40 x 1 Fil.).....	I-46
74841	Strap.....	I-32	75436	Resistor.....	I-2
74842	Type Bar (with Pallet).....	I-37	75437	Test Key.....	I-13
74843	Type Bar (with Pallet).....	I-36	75525	Celluloid Keytop.....	I-40
74844	Type Bar (with Pallet).....	I-37	75578	Celluloid Keytop.....	I-40
74845	Type Bar (with Pallet).....	I-37,69	75606	Spring.....	I-12
74846	Type Bar (with Pallet).....	I-37	75607	Washer.....	I-12
74847	Type Bar (with Pallet).....	I-36	75652	Celluloid Keytop.....	I-39
74848	Type Bar (with Pallet).....	I-36	75653	Celluloid Keytop.....	I-40
74849	Type Bar (with Pallet).....	I-37	75654	Celluloid Keytop.....	I-40
74853	Power Cord.....	I-9	75655	Celluloid Keytop.....	I-39
74855	Cross Bar.....	I-27	75656	Celluloid Keytop.....	I-40
74875	Ribbon Carrier.....	IV-2	75657	Celluloid Keytop.....	I-39
74877	Spring.....	IV-2	75658	Celluloid Keytop.....	I-40
74878	Drag Spring.....	I-25	75689	Spring.....	I-63,64
74879	Spring Post.....	I-15	75701	Celluloid Keytop.....	I-40
74882	Spring.....	I-18	75702	Celluloid Keytop.....	I-40
74885	Lever.....	I-3	75704	Celluloid Keytop.....	I-40
74889	Mounting Block.....	I-22,III-3	75750	Washer - Fiber.....	I-2,7,10,46,64 III-1,3
74890	Contact Assembly....	I-8,50,53,73,74	75851	Set of Keytops-Celluloid....	I-39,40
74891	Shim (.004").....	I-11	75852	Celluloid Keytop.....	I-39
74892	Shim (.004").....	I-11,12			
74894	Identification Plate.....	I-48			

Part Number	Description	Page	Part Number	Description	Page
75886	Celluloid Keytops.....	I-40	78826	Mounting Block.....	I-32
through 75889	Celluloid Keytop.....	I-40	78889	Insulator.....	I-6
75891	Celluloid Keytop.....	I-40	78905	Washer-Fiber.....	I-44
75893	Celluloid Keytops.....	I-40	78932	Set of Keytops - Spring Cushion.....	I-30 40
through 75895	Washer-Felt.....	I-24	78935	Set of Keytops-Spring Cushion...I-39	40
76084	Friction Disk.....	I-24	78936	Set of Keytops-Spring Cushion...I-39	40
76085	Spring Washer.....	I-24	78939	Set of Keytops-Spring Cushion...I-39	40
76086	Nut (9/16-32 Special).....	I-24	78940	Set of Keytops-Spring Cushion...I-39	40
76087	Washer.....	I-1,46,47,48,73	78946	Spring Cushion Keytop.....	I-39
76099	Washer.....	I-26,28	78947	Spring Cushion Keytop....I-39;II-2,3	
76156	Screw (4-40 x 3/16 Hex).....	I-22	78948	Spring Cushion Keytop....I-39;II-2,3	
76167	Bushing.....	I-3,71	78949	Spring Cushion Keytop.....	I-39
76246	Screw (6-40 Shoulder).....	I-72	78950	Spring Cushion Keytop.....	I-39
76260	Plate.....	I-57	78951	Spring Cushion Keytop....I-39;II-2,3	
76275	Eccentric.....	I-63	78952	Spring Cushion Keytop.....	I-39
76277	Terminal.....	I-46	78953	Spring Cushion Keytop....I-39;II-2,3	
76281	Wire.....	I-7	78954	Spring Cushion Keytop.....	I-39
76284	Spring.....	I-17	78955	Spring Cushion Keytop....I-39;II-2,3	
76296	Bushing.....	I-3	78956	Spring Cushion Keytop....I-40;II-2,3	
76333	Nut (10-32 Hex).....	II-1	78957	Spring Cushion Keytop....I-40;II-2,3	
76474	Fan.....	I-41,42	78958	Spring Cushion Keytop.....	I-40
76484	Screw (10-32 Pilot).....	I-1,51	78959	Spring Cushion Keytop....I-40;II-2,3	
76699	Bushing.....	I-64	78960	Spring Cushion Keytop.....	I-40
76790	Screw (10-32 x 3/16 Set).....	I-73	78961	Spring Cushion Keytop.....I-40;II-3	
76966	Contact Spring.....	III-3	78962	Spring Cushion Keytop.....	I-40
77038	Contact Spring.....	III-3	78963	Spring Cushion Keytop.....	I-40
77040	Contact Spring.....	III-3	78964	Spring Cushion Keytop.....	I-40
77041	Celluloid Keytop.....	I-40	78965	Spring Cushion Keytop.....	I-40
77214	Celluloid Keytop.....	I-40	78966	Spring Cushion Keytop....I-40;II-2,3	
77216	Resistor.....	I-7	78967	through Spring Cushion Keytops.....	I-40
77362	Screw (6-40 x 2-3/8 Rd. Hd.)..	III-1	78974	Spring Cushion Keytop.....	I-40
77902	Screw (6-40 x 1-15/16 Fil.)..	I-4,64 III-3	78976	Spring Cushion Keytop.....	I-40
77920	Cover.....	I-6	78978	Spring Cushion Keytop.....	I-40
77977	Capacitor.....	I-5,6,64	78979	Spring Cushion Keytop.....	I-40
78011	Screw (4-48 x 3/16 Rd. Hd.)....	I-42	78980	Spring Cushion Keytop.....	I-40
78025	Screw (6-40 x 15/16 Hex).....	I-5,44	78981	Spring Cushion Keytop.....I-39;II-2	
78028	Spring Post.....	I-68	78982	Spring Cushion Keytop.....I-39;II-3	
78044	Screw (6-40 x 1-3/16 Hex).....	I-46	78983	Spring Cushion Keytop.....I-40;II-3	
78103	Post.....	I-30,33	78984	Spring Cushion Keytop.....I-39;II-3	
78163	Stud.....	I-30,33	78985	Spring Cushion Keytop.....I-40;II-3	
78164	Resistor.....	I-6,45	78986	Spring Cushion Keytop.....I-39;II-3	
78205	Resistor Assembly.....	I-6,45;II-3	78987	Spring Cushion Keytop.....I-40;II-3	
78206	Spacing Collar.....	I-5	78988	Spring Cushion Keytop.....I-40;II-3	
78287	Screw (10-32 x 5/8 Hex).....	I-17,41 42,43	78990	Spring Cushion Keytop.....	I-40
78301	Terminal.....	I-7	78991	Spring Cushion Keytop.....	I-39
78363	Connector.....	III-1	78993	Spring Cushion Keytop....I-39;II-3	
78374	Cable Clamp.....	I-65	78994	Spring Cushion Keytop.....	I-39
78430	Resistor.....	I-45	78995	Spring Cushion Keytop.....	II-2
78473	Friction Washer.....	I-31,32	79513	Plate....I-6,8,50,53,56,73,74;II-1,2	
78596	Screw (10-32 Shoulder).....	I-31,32	79523	Screw (2-56 x 25/32 Fil.).....	I-2
78597	Celluloid Keytop.....	I-40	79716	Stiffener.....	II-1
78646	Celluloid Keytop.....	I-40	80138	Spring Cushion Keytop.....	I-50
78648	Celluloid Keytop.....	I-40	80146	Screw (1/4-32 Special).....	I-26,28
78650	Celluloid Keytop.....	I-40	80148	Type Pallet.....	I-37
78651	Celluloid Keytop.....	I-40	80149	Type Pallet.....	I-36
78652	Celluloid Keytop.....	I-40	80216	Platen - Rubber Covered.....	I-28
78661	Celluloid Keytop.....	I-40			
78824	Spring.....	I-24,33			

Part Number	Description	Page	Part Number	Description	Page
80217	Platen - Rubber Covered.....	I-28	80725	Handwheel Assembly.....	I-24
80248	Platen - Rubber Covered.....	I-28	80755	Bushing.....	I-7,62,65
80249	Platen - Rubber Covered.....	I-28	80757	Screw (10-32 x 1/2 Fil.).....	I-14,15
80255	Screw (4-40 x 21/64 Fil.).....	I-54;IV-2	80765	Platen - Steel Jacketed.....	I-28
80294	Spring Post.....	I-24	80766	Platen - Steel Jacketed.....	I-28
80334	Terminal.....	I-58;II-1	80826	Bracket.....	I-58
80341	Governor Brush and Speed Adjusting Bracket Assembly.....	I-43	80827	Lamp.....	I-58
80342	Screw (6-40 x 23/64 Hex).....	I-1,11,42 54,56,57,63;III-1;IV-4	80832	Bracket.....	I-66
80352	Governor.....	I-43	80833	Guard Spring.....	I-66
80374	Set of Gears.....	I-41	80840	Terminal Block.....	I-45
80392	Spring.....	I-10	80848	Spring.....	I-17
80395	Paper Guide Strip.....	I-27	90860	Set of Type Pallets - Murray Style.. Fractions.....	I-36
80396	Bracket.....	I-27	80861	Type Pallet.....	I-37
80397	Retarding Rod.....	I-27	80862	Type Pallet.....	I-36
80398	Pulley.....	IV-2	80863	Type Pallet.....	I-37
80399	Paper Carrier Belt.....	IV-2	80864	Type Pallet.....	I-37
80400	Bracket.....	I-27	80865	Type Pallet.....	I-36
80401	Spring.....	I-27	80866	Type Pallet.....	I-37
80402	Screw (4-40 x 15/32 Fil.).....	I-27	80867	Type Pallet.....	I-37
80403	Screw (6-40 Shoulder).....	I-27	80868	Set of Type Pallets-Murray Style.....	I-36
80405	Baffle Plate.....	I-27	80869	Rail - Right.....	I-47
80407	Shaft.....	I-27	80870	Rail - Left.....	I-47
80412	Clamp.....	I-27	80875	Cover Arm.....	I-47
80413	Pressure Roller.....	I-27;IV-2	80876	Mounting Strap.....	I-47
80415	Sprocket Ring.....	I-28	80911	Conduit.....	I-45
80420	Paper Guide.....	I-27	80913	Resistor Assembly.....	I-45;IV-3
80421	Spacer.....	I-27	80919	Function Lever.....	I-35
80422	Platen - Rubber Covered.....	I-28	80924	Set of Type Pallets-Murray Style.....	I-36
80437	Set of Gears.....	I-41	80925	Connector.....	I-45
80444	Screw (6-40 x 1/4 Hex).....	I-7,45,51 57,61,66	80926	Spring.....	I-19
80451	Platen - Rubber Covered.....	I-28	80929	Receptacle.....	I-65
80458	Screw (6-40 Special).....	I-26	80948	Wood Screw.....	I-45
80459	Screw Assembly.....	I-26,28	80956	Set of Parts for Remote Signal Bell Contacts.....	I-65
80460	Cable Clamp.....	I-1	80985	Screw (4-40 Fil.).....	I-61
80466	Crank Assembly.....	I-24	80986	Lock Washer.....	I-61
80471	Spring.....	I-11	81006	Stop Post.....	I-15
80478	Spring Post.....	I-25,27	81015	Cable Clamp.....	I-4
80479	Collar.....	I-27	81024	Platen - Rubber Covered.....	I-28
80481	Post.....	I-27	81025	Platen - Rubber Covered.....	I-28
80483	Set of Parts for Converting Friction Feed Printers to Sprocket Feed.....	I-27	81026	Screw Assembly.....	I-26,28
80488	Post.....	I-27	81027	Stud.....	I-26,28
80489	Function Lever.....	I-35	81028	Spacing Post.....	I-26,28
80509	Spring Post.....	I-15	81029	Screw (1/4-32 Special).....	I-26,28
80510	Margin Bell Hammer.....	I-15	81299	Bushing.....	I-56;II-2
80511	Margin Bell Shaft.....	I-15	81564	Screw (6-40 Special).....	I-58
80516	Cotter Pin.....	I-17	81595	Screw (4-40 Eccentric Shoulder).....	I-63 64
80564	Signal Bell.....	III-1	81726	Terminal.....	I-71,72
80565	Signal Bell.....	III-1	81729	Type Pallet.....	I-38
80598	Platen - Rubber Covered.....	I-28	81730	Type Bar (with Pallet).....	I-38
80599	Platen - Rubber Covered.....	I-28	81747	Insulator Block.....	I-17
80600	Platen - Rubber Covered.....	I-28	81760	Type Pallet.....	I-37
80601	Platen - Rubber Covered.....	I-28	81774	Washer - Brass.....	I-5
80706	Screw (6-40 x 3/16 Set).....	I-28	81775	Resistor (8000 ohms).....	I-2
80721	Washer.....	I-29	81778	Screw (4-40 x 3/16 Fil.).....	I-7
80722	Platen - Rubber Covered.....	I-28	81784	Function Lever.....	I-35
80723	Platen - Rubber Covered.....	I-28	81800	Contact Assembly.....	I-56;II-2
80724	Paper Rod Lever.....	I-25	81801	Platen - Steel Jacketed.....	I-28
			81802	Platen - Steel Jacketed.....	I-28
			81805	Platen - Steel Jacketed.....	I-28

Part Number	Description	Page	Part Number	Description	Page
81806	Platen - Steel Jacketed.....	I-28	82474	Terminal.....	I-4,7,9,44,45,46,53,66 71,72
81825	Capacitor.....	I-46	82493	Washer.....	I-32
81836	Washer - Fiber.....	I-4,5	82498	Type Pallet.....	I-37
81841	Capacitor.....	I-3	82499	Set of Type Pallets-Murray Style	I-36
81889	Spring Bracket.....	I-22	82507	Plate.....	I-7,60
81893	Spring Bracket.....	I-22	82508	Relay Assembly.....	I-6
81895	Spring Post.....	I-18	82516	Spring.....	I-2
81936	Feed Lever.....	I-23	82518	Mounting Plate.....	I-7
81956	Blocking Bail.....	I-20,76	82519	Bracket.....	I-7
82009	Contact Lever.....	I-65	82525	Shim (.004").....	I-7
82011	Type Pallet.....	I-38	82526	Armature.....	I-7
82012	Spring.....	I-27,61	82529	Lever.....	I-7
82015	Resistor.....	I-7	82530	Spring Post.....	I-7
82021	Type Bar (with Pallet).....	I-38	82531	Bracket.....	I-7
82024	Set of Type Pallets - Murray Style	I-36	82532	Screw (6-40 Shoulder).....	I-7
82025	Type Pallet.....	I-38	82537	Spring Post.....	I-7
82075	Spring.....	I-17	82538	Screw (6-40 x 5/16 Hex).....	I-7
82147	Type Pallet.....	I-36	82539	Armature.....	I-7
82148	Type Pallet.....	I-36	82540	Hinge Pin.....	I-7
82149	Type Pallets.....	I-37	82541	Lever.....	I-7
through	Type Pallets.....	I-37	82542	Contact Spring.....	I-7
82154	Platen - Rubber Covered.....	I-28	82544	Contact Spring.....	I-7
82172	Platen - Rubber Covered.....	I-28	82547	Insulator.....	I-7,8,58
82173	Platen - Rubber Covered.....	I-28	82548	Insulator.....	I-7,8,65
82174	Platen - Rubber Covered.....	I-28	82549	Mounting Plate.....	I-8
82175	Platen - Rubber Covered.....	I-28	82550	Contact Spring.....	I-8
82176	Type Pallet.....	I-36	82553	Contact Spring.....	I-7
82177	Type Pallet.....	I-38	82555	Contact Spring.....	I-7
82178	Type Bar (with Pallet).....	I-36	82557	Stiffener.....	I-7
82179	Type Bar (with Pallet).....	I-38	82559	Bushing.....	I-8
82253	Platen - Steel Jacketed.....	I-26	82588	Type Bar (with Pallet).....	I-37
82271	Function Lever.....	I-8,35,50,56;II-2	82589	Type Bar (with Pallet).....	I-36
82272	Type Pallet.....	I-38	82590	Type Bar (with Pallet).....	I-36
82283	Synchronous Motor.....	I-41	82591	Type Bar (with Pallet).....	I-38
82289	Type Pallet.....	I-38	82592	Type Bar (with Pallet).....	I-38
82290	Type Pallet.....	I-38	82593	Type Bar (with Pallet).....	I-37
82291	Type Pallet.....	I-38	82594	Type Bar (with Pallet).....	I-37
82346	Resistor Assembly.....	I-6	82595	Type Bars(with Pallets).....	I-38
82363	Signal Bell.....	III-1	through	Type Bar (with Pallet).....	I-36
82368	Incandescent Lamp.....	I-45	82598	Type Bars(with Pallets).....	I-37
82399	Pad - Felt.....	I-47	82599	Spring Cushion Keytop.....	I-40
82401	Pad - Felt.....	I-47	82600	Spring Cushion Keytop.....	I-40
82402	Pad - Felt.....	I-47	through	Spring Cushion Keytop.....	I-8,39,50;II-3
82403	Pad - Felt.....	I-47	82602	Spring Cushion Keytops.....	I-39
82411	Bracket.....	IV-3	82605	Spring Cushion Keytop.....	I-40
82412	Bracket.....	IV-3	82606	Magnet Yoke.....	I-7
82413	Arm.....	IV-3	82607	Magnet Yoke.....	I-7
82414	Detent Knob.....	I-47,68	82620	Cable.....	I-8,53,56,73;II-2,4
82415	Spring.....	I-47	82633	Screw (6-40 x 9/32 Flat Hd.).....	I-44 66,72
82420	Type Pallet.....	I-36	82702	Cable.....	I-8
82421	Type Pallet.....	I-37	through	Synchronous Motor.....	I-41
82422	Type Pallet.....	I-38	82612	Type Pallet.....	I-38
82423	Type Pallet.....	I-36	82613	Spring Cushion Keytop.....	I-40
82425	Cover Glass.....	I-47	82617	Magnet Yoke.....	I-7
82440	Screw (6-40 x 7/16 Hex)...	I-11,29,31 42,44,54,60;III-3	82620	Magnet Yoke.....	I-7
82442	Spring.....	I-15	82633	Cable.....	I-8,53,56,73;II-2,4
82444	Bushing.....	I-58	82702	Screw (6-40 x 9/32 Flat Hd.).....	I-44 66,72
82463	Spring.....	I-24	82704	Cable.....	I-8
			82714	Synchronous Motor.....	I-41
			82718	Type Pallet.....	I-38

Part Number	Description	Page	Part Number	Description	Page
82728	Identification Plate.....	I-48	83412	Locating Stud.....	I-1
82729	Identification Plate.....	I-48	83413	Buffer.....	I-1
82733	Bearing Cap.....	I-15	83419	Spring.....	I-7
82740	Contact Assembly.....	I-50	83421	Pad-Felt.....	I-47
82742	Set of Parts for Mechanical Motor Control.....	I-50	83538	Type Pallet.....	I-37
82750	Set of Type Pallets-Murray Style (Weather Map Service)....	I-36;IV-3	83539	Type Pallet.....	I-38
82751	Type Pallet.....	I-37	83540	Celluloid Keytop.....	I-40
82767	Set of Type Pallets Murray Style.....	I-36	83571	Eccentric.....	I-50,70
82770	Type Pallet.....	I-38	83572	Paper Guide Plate.....	I-47
82771	Type Pallet.....	I-38	83718	Set of Parts Sixth Vane Extension..	I-17
82787	Spring.....	I-50	83760	Insulator.....	I-7
82788	Spring.....	I-8,35,50,56;II-2	83799	Synchronous Motor.....	I-41
82859	Set of Keytops-Spring Cushion.....	I-39,40	83861	Type Pallet.....	I-38
82865	Bracket.....	I-2	83862	Celluloid Keytop.....	I-40
82866	Resistor.....	I-2,10	83863	Celluloid Keytop.....	I-40
82868	Resistor and Bracket Assembly...	I-2	83864	Celluloid Keytop.....	I-40
82871	Set of Type Pallets-Gothic Style...	I-36	83884	Screw (10-32 x 3-3/4 Hex).....	I-14
82873	Type Pallet.....	I-37	83885	Nut (6-32 Hex).....	I-47,48;IV-3
82874	Type Pallet.....	I-37	83902	Spring Cushion Keytop.....	I-39
82875	Type Pallet.....	I-36	83904	Spring Cushion Keytop.....	I-40
82876	Type Pallet.....	I-36	83906	Spring Cushion Keytop.....	I-40
through	Type Pallets.....	I-37	83914	Contact Spring.....	I-65,71
82884	Type Pallet.....	I-36	83920	Top Separator Plate.....	I-30,33
82885	Type Pallet.....	I-36	83976	Platen Crank.....	I-24
82886	Type Pallet.....	I-37	83977	Clip.....	I-24
82887	Type Pallet.....	I-36	83979	Extension.....	I-24
82888	Type Pallet.....	I-37	84018	Pinion (7T).....	I-41
82889	Type Pallet.....	I-37	84019	Gear (25T).....	I-41
82890	Type Pallet.....	I-37	84025	Type Pallet.....	I-37
through	Type Pallets.....	I-36	84040	Bushing.....	I-7;II-1
82892	Type Pallet.....	I-36	84042	Set of Gears.....	I-41
82893	Type Pallet.....	I-36	84047	Stop Plate.....	I-43
through	Type Pallets.....	I-37	84060	Function Lever.....	I-35;IV-3
82898	Type Pallet.....	I-37	84069	Type Pallet.....	I-37
82917	Send-Receive-Break Mechanism.....	I-3;III-3	84073	Mounting Plate.....	I-61
82918	Bracket.....	I-3	84076	Tearing Edge Bracket.....	I-61
82919	Bearing.....	I-3	84077	Blade.....	I-61
82920	Bushing.....	I-3	84079	Lever - Left.....	I-27,61
82921	Break Lever.....	I-3	84081	Lever - Right.....	I-27,61
82922	Adjusting Plate.....	I-3	84082	Screw (6-40 x 13/32 Fil).....	I-61
82923	Stop Lever.....	I-3	84105	Pinion (8T).....	I-41
82924	Plate.....	I-3	84106	Gear (32T).....	I-41
82925	Upper Contact Lever.....	I-3	84114	Yoke.....	I-72
82927	Contact Spring.....	I-3,72	84115	Armature.....	I-72
82930	Contact Spring.....	I-3,62	84466	Test Key.....	I-13
82963	Extension.....	I-17	84530	Celluloid Keytop.....	I-40
82964	Screw (4-40 Shoulder).....	I-17	84531	Celluloid Keytop.....	I-40
82965	Spring.....	I-17	84532	Celluloid Keytop.....	I-40
82966	Letters Push Bar.....	I-17	84535	Celluloid Keytop.....	I-40
82986	Screw (1/4-32 Pilot).....	I-19	84536	Celluloid Keytop.....	I-40
82988	Screw (6-40 x 2-1/2 Rd. Hd.)...	I-72	84575	Spring.....	I-34;III-3
82999	Spring.....	I-22	84578	Bearing Block.....	I-18
83054	Capacitor.....	I-44	84579	Spacer.....	I-7
83355	Washer-Fiber.....	I-59	84687	Type Pallet.....	I-38
83408	Screw (4-40 x 3/16 Rd. Hd.)....	I-31	84705	Contact Spring.....	II-2
		II-2,3,4	84708	Type Bar (with Pallet).....	I-37
			84709	Type Bar (with Pallet).....	I-37
			84710	Type Bar (with Pallet).....	I-36

Part Number	Description	Page	Part Number	Description	Page
84711	Type Bars (with Pallets).....	I-37	86193	Set of Parts for Converting Bell System 15C** Keyboard to 15A**II-2	
through 84719	Type Bar (with Pallet).....	I-36	86461	Spring Cushion Keytop.....	I-39
84720	Type Bar (with Pallet).....	I-37	86462	Spring Cushion Keytop.....	I-40
84721	Type Bar (with Pallet).....	I-36	86463	Spring Cushion Keytop.....	I-39
84722	Type Bar (with Pallet).....	I-37	86466	Spring Cushion Keytop.....	I-40
84723	Type Bar (with Pallet).....	I-37	86630	Celluloid Keytop.....	I-40
84724	Type Bar (with Pallet).....	I-37	86631	Celluloid Keytop.....	I-40
84725	Type Bars (with Pallets).....	I-36	86635	Set of Type Pallets - Long Gothic Style.....	I-36
through 84727	Type Bars (with Pallets).....	I-37	86636	Type Pallet.....	I-37
84728	Type Bars (with Pallets).....	I-37	86637	Type Pallet.....	I-37
through 84733	Type Bar (with Pallet).....	I-37;IV-3	86638	Type Pallet.....	I-36
84734	Type Bar (with Pallet).....	I-37	86639	Type Pallet.....	I-37
84735	Type Bar (with Pallet).....	I-37	86641	Type Pallet.....	I-37
84736	Type Bar (with Pallet).....	I-37	86643	Type Pallet.....	I-37
84737	Type Bar (with Pallet).....	I-36	86644	Type Pallet.....	I-37
84738	Type Bars (with Pallets).....	I-37	86647	Type Pallet.....	I-37
through 84740	Type Bar (with Pallet).....	I-38	86650	Type Pallet.....	I-36
84741	Type Bar (with Pallet).....	I-37	86651	Type Pallet.....	I-37
84742	Type Bar (with Pallet).....	I-36	86653	Type Pallets.....	I-36
84743	Type Bar (with Pallet).....	I-37	through 86655	Type Pallets.....	I-37
84744	Type Bar (with Pallet).....	I-37	86657	Type Pallets.....	I-37
84745	Type Bar (with Pallet).....	I-36	through 86661	Type Pallet.....	I-38
84746	Type Bar (with Pallet).....	I-36	86662	Type Pallet.....	I-38
84747	Type Bar (with Pallet).....	I-38	86663	Type Pallet.....	I-38
84748	Type Bar (with Pallet).....	I-37	86667	Screw Assembly.....	I-26,28
84749	Type Bar (with Pallet).....	I-37	86668	Stud.....	I-26,28
84750	Type Bar (with Pallet).....	I-38	86669	Screw (1/4-32 Special).....	I-26,28
84751	Type Bar (with Pallet).....	I-37	86710	Oil Cup.....	I-14,19
84752	Type Bar (with Pallet).....	I-38	86732	Spring Cushion Keytop.....	I-39,51
84753	Type Bar (with Pallet).....	I-38	86758	Plate.....	I-51,73
84754	Type Bar (with Pallet).....	I-37	86759	Tabulator Bar.....	IV-3
84755	Type Bar (with Pallet).....	I-38	86760	Bearing.....	I-51
84756	Type Bar (with Pallet).....	I-35,51	86761	Spring Post.....	I-51
84792	Function Lever.....	I-40,51	86762	Tabulator Stop.....	IV-3
84799	Spring Cushion Keytop.....	I-38	86763	Tabulator Stop.....	IV-3
84890	Stiffener.....	I-65,72;II-1	86764	Nut (4-40 Special).....	I-51
84892	Set of Parts to Provide Spacing for 8 Characters per Inch.....	I-69	86765	Adapter Block.....	I-51
84893	Arm.....	I-23	86766	Tabulator Latch.....	I-51
84894	Detent Spring.....	I-23	86768	Function Lever.....	I-35,51
84895	Screw (10-32 Shoulder).....	I-28	86769	Latch Bar.....	I-51
84896	Platen - Rubber Covered.....	I-25	86770	Bracket.....	I-51
84902	Set of Parts for Converting Sprocket Feed Printers to Friction Feed.....	I-25	86771	Extension.....	I-51
84913	Set of Parts for Tabulator.....	I-51	86772	Screw (6-40 Eccentric).....	I-51
84925	Function Lever.....	I-35	86773	Link.....	I-51
84927	Function Lever.....	I-35	86774	Screw (6-40 Shoulder).....	I-51,70
84928	Roller - Cork.....	I-25	86776	Post.....	I-51
84966	Roller - Cork.....	I-10	86777	Retainer.....	I-51
84967	Space Bar.....	I-63,64	86779	Pawl.....	I-51
85098	Spring Post.....	I-69	86828	Bracket.....	I-62
85993	Detent Spring.....	I-62	86829	Lever.....	I-62
86007	Set of Parts for Converting Bell System 15C** Keyboard to 15B**II-2	I-5;IV-1	86830	Mounting Plate.....	I-62
86192			86835	Spring.....	I-57
			86841	Celluloid Keytop.....	I-40
			86850	Screw (10-32 x 1-1/4 Fil).....	I-5;IV-1

Part Number	Description	Page	Part Number	Description	Page
86873	Spring.....	I-34,35	88969	Spring.....	I-56
86951	Resistor.....	I-70-72	89076	Bracket.....	I-34
86959	Bushing.....	I-72;II-2	89077	Stud.....	I-14,34
87136	Lever.....	I-66	89097	Spacing Pawl Arm.....	I-19,51
87154	Set of Parts to Provide a Paper Guide.....	I-27	89208	Spring Cushion Keytop.....	I-40
87182	Disk.....	I-10	89217	through Type Bars (with Pallets).....	I-38
87401	Spring.....	I-20	89220		
87402	Spring.....	I-35	89221		
87403	Set of parts to Adapt a Mech. or Elect. Motor Control to Operate on Shift-Blank-Stop.....	I-56	through Type Pallets.....	I-38	
87483	Type Pallet.....	I-38	89224		
87490	Type Pallet.....	I-38	89225	Spring Cushion Keytop.....	I-40
87509	Spring Post.....	I-19;IV-1	89226	Spring Cushion Keytop.....	I-39
87573	Type Pallet.....	I-37	89227	Spring Cushion Keytop.....	I-40
87636	Screw (2-56 x 3/16 Rd.Hd.).....	I-48	89228	Spring Cushion Keytop.....	I-40
87692	Set of Parts for Feeding Four Lines per Inch.....	I-57	89317	Line Cord.....	I-9
87693	Set of Parts for Bell System Name Plate.....	II-2	89324	through Type Pallets.....	I-38
87851	Bushing - Fiber.....	I-3	89326		
87852	Line Feed Ratchet.....	I-57	89327	through Type Bars (with Pallets).....	I-38
87853	Detent Ratchet.....	I-57	89329		
87860	Set of Parts for Tabulator.....	I-51	89352	Spring Cushion Keytop.....	I-40
87868	Set of Parts for Converting Bell System 15S and 15T Typing Units to 15J and 15L (Upper Case "H" Contact Mechanism).....	I-56;II-2	89353	Type Pallet.....	I-38
87936	Bracket.....	III-2	89396	Type Pallet.....	I-38
87937	Bracket.....	III-2	89397	Type Pallet.....	I-37
87938	Bracket.....	III-2	89398	Type Pallet.....	I-36
87949	Type Pallet.....	I-38	89399	Type Pallet.....	I-38
87979	Cover Lid.....	I-47	89400	Type Pallet.....	I-38
87980	Cover Lid.....	I-47	89401	Spring Cushion Keytop.....	I-39
87993	Screw (6-40 x 5/32 Fil.).....	I-20,46	89402	Spring Cushion Keytop.....	I-40
88033	Power Cord.....	I-53	89403	Spring Cushion Keytop.....	I-40
88651	Set of Keytops - Celluloid.....	I-39,40	89404	Spring Cushion Keytop.....	I-39
88745	Screw (6-40 Special).....	I-26	89410	Set of Keytops.....	I-39,40
88746	Screw (1/4-32 Special).....	I-26	89413	Spring Cushion Keytop.....	I-40
88777	Screw Assembly.....	I-26	89414	through Spring Cushion Keytops.....	I-39
88832	Platen - Rubber Covered.....	I-28	89419		
88833	Platen - Rubber Covered.....	I-28	89420	through Spring Cushion Keytops.....	I-40
88846	Type Bar (with Pallet).....	I-38	89422		
88847	Type Bar (with Pallet).....	I-38	89423	Spring Cushion Keytop.....	I-39
88848	Type Bar (with Pallet).....	I-38	89424	Spring Cushion Keytop.....	I-40
88849	Spring Cushion Keytop.....	I-39	89425	Spring Cushion Keytop.....	I-39
88850	Spring Cushion Keytop.....	I-40	89426	Spring Cushion Keytop.....	I-40
88851	Spring Cushion Keytop.....	I-39	89438	Line Cord.....	I-9
88855	Spring Cushion Keytop.....	I-40	89442	Downstop Assembly.....	I-34
88856	Stud.....	I-17	89469	Power Cord.....	I-9
88857	Spring Washer.....	I-17	89472	Line Cord.....	I-9
88877	Lacing; Black.....	I-47,48	89535	Bumper.....	I-67
88878	Spring Cushion Keytop.....	I-39	89540	Platen - Rubber Covered.....	I-28
88947	Spindle Disk.....	I-57	89541	Type Bar (with Pallet).....	I-38
88959	Guide Bracket.....	I-54,56	89542	Type Bar (with Pallet).....	I-38
88962	Adapter Plate.....	I-56	89543	Type Pallet.....	I-38
88963	Spring Bracket.....	I-56	89544	Type Pallet.....	I-38
88966	Blocking Lever.....	I-56	89545	Spring Cushion Keytop.....	I-39
88967	Retainer Plate.....	I-56	89546	Spring Cushion Keytop.....	I-40
88968	Stud.....	I-56	89547	Type Pallet.....	I-38
			89548	Contact Spring.....	I-2
			89576	Washer.....	I-65
			89734	Type Pallet.....	I-36

Part Number	Description	Page	Part Number	Description	Page
89735	Type Pallet.....	I-37	90227		
89736	Type Pallet.....	I-37	through	Type Bars (with Pallets).....	I-37
89858	Pressure Roller.....	I-27,82	90229		
89881	Wick.....	I-16	90230	Type Bar (with Pallet).....	I-36
89896	Oil Cup.....	I-11,12,17	90231	Type Bar (with Pallet).....	I-37
89897	Nut (10-32 Hex).....	I-11,12,17	90246	Resistor.....	I-2
89917	Screw (4-40 Eccentric).....	I-12	90247	Resistor.....	I-2
89925	Terminal Block.....	I-6,45	90248	Resistor.....	I-2
89932	Type Pallet.....	I-36	90249	Set of Parts for Tabulator Indication.....	I-57
89933	Type Pallet.....	I-37	90250	Bracket.....	I-57
89934	Type Pallet.....	I-37	90251	Indicator.....	I-57
89936	Type Pallet.....	I-36	90252	Scale.....	I-57
89937	Type Pallet.....	I-37	90253	Set of Parts for Converting Bell System 15S Typing Unit to a 15E.....	II-2
89946	Name Plate.....	I-42	90254	Set of Parts for Converting Bell System 15K Typing Unit to a 15F.....	II-3
89969	Washer - Fiber.....	I-2,44,70,72	90255	Set of Parts for Converting Bell System 15T Typing Unit to a 15G.....	II-3
89971	Platen - Steel Jacketed.....	I-28	90256	Set of Parts for Converting Bell System 15M Typing Unit to a 15H.....	II-3
89972	Platen - Steel Jacketed.....	I-28	90260	Spring.....	I-12
89992	Set of Parts to Control Transmitter Distributor (XD) from Tabulator..	I-52	90265	Screw (6-40 Special).....	I-29
89993	Tabulator Bar Extension.....	I-52	90273	Cord Clamp.....	I-1
89994	Bracket.....	I-52	90275	Spring Cushion Keytop.....	I-39
89995	Tabulator Contact Lever.....	I-52	90276	Type Pallet.....	I-39
89996	Screw (4-40 x 63/64 Fil.).....	II-1	90277	Type Pallet.....	I-38
90024	Retainer.....	I-29	90278	Type Pallet.....	I-39
90043	Armature Bracket.....	I-29	90279	Type Pallet.....	I-38
90069	Post.....	I-29	90281	Celluloid Keytop.....	I-40
90088	Latch.....	I-31	90282	Celluloid Keytop.....	I-40
90101	Set of Keytops - Spring Cushion (Weather Map Service).....	I-39,40;IV-3	90283	Celluloid Keytop.....	I-40
90103	Set of Parts to Disseminate Weather Map Data.....	IV-3	90284	Set of Type Pallets-Large Gothic Style.....	I-36,69
90192	Type Bar (with Pallet).....	I-37	90287	Detent Lever.....	I-56,69
90193	Type Bar (with Pallet).....	I-37	90288	Rack.....	I-69
90194	Type Bar (with Pallet).....	I-36	90289	Spacing Gear - Upper.....	I-69
90195			90421	Spacer.....	I-63,64
through	Type Bars (with Pallets).....	I-37	90438	Wick.....	I-11,12
90203			90505	Locking Lever.....	I-30
90204	Type Bar (with Pallet).....	I-36	90507	Top Plate.....	I-30
90205	Type Bar (with Pallet).....	I-37	90508	Spring Arm.....	I-30
90206	Type Bar (with Pallet).....	I-36	90509	Detent.....	I-29
90207	Type Bar (with Pallet).....	I-37	90510	Spring.....	I-29
90208	Type Bar (with Pallet).....	I-37	90511	Screw (6-40 x 13/16 Hex).....	I-15,19,29
90209			90512	Bracket.....	I-29
through	Type Bars (with Pallets).....	I-36	90513	Screw (6-40 Eccentric).....	I-29
90211			90514	Screw (3/16-40 Pivot).....	I-29
90212			90515	Screw (3/16-40 Pivot).....	I-29
through	Type Bars (with Pallets).....	I-37	90516	Selector Arm.....	I-29
90217			90517	Spring.....	I-29
90218	Type Bar (with Pallet).....	I-38	90518	Locking Wedge.....	I-29
90219	Type Bar (with Pallet).....	I-37	90519	Screw (2-56 x 3/16 Special).....	I-29
90220	Type Bar (with Pallet).....	I-36	90520	Armature Lever.....	I-29
90221	Type Bar (with Pallet).....	I-38	90524	Screw (4-40 Special).....	I-29
90222	Type Bar (with Pallet).....	I-38			
90223	Type Bar (with Pallet).....	I-36			
90224	Type Bar (with Pallet).....	I-37			
90225	Type Bar (with Pallet).....	I-37			
90226	Type Bar (with Pallet).....	I-36			

Part Number	Description	Page	Part Number	Description	Page
90599	Shim (.008").....	I-60	91519	Blocking Bail.....	I-76
90752	Washer - Felt.....	I-1	91521	Set of Type Pallets - Murray Style.....	I-36
90760	Range Scale Assembly.....	I-31	91526	Type Pallet.....	I-38
90774	Bell Crank.....	I-31	91527	Type Pallet.....	I-38
90775	Range Scale.....	I-31	91528	Spring Cushion Keytop.....	I-40
90791	Lock Washer.....	I-29, 32, 68	91578	Type Bar (with Pallet).....	I-38
90814	Resistor (1000 OHMS).....	I-4	91600	Screw (6-40 x 31/32 Hex).....	I-17
90815	Resistor.....	III-3	91610	Type Pallet.....	I-38
90951	Lock Washer.....	I-54	91611	Type Bar (with Pallet).....	I-38
91013	Type Pallet.....	I-38	91617	Shim (.010").....	I-43
91018	Type Bar (with Pallet).....	I-38	91619	Spring Cushion Keytop.....	I-39
91032	Spring Cushion Keytop.....	I-39	91621	Window.....	II-2
91033	Spring Cushion Keytop.....	I-39	91657	Lever Assembly.....	I-22
91034	Spring Cushion Keytop.....	I-39	91658	Extension.....	I-22
91043	Type Pallet.....	I-37	91659	Lockout Lever.....	I-22
91044	Type Pallet.....	I-37	91683	Nut (15/32-32 Hex).....	I-2, 45; III-3
91045	Type Pallet.....	I-36	91684	Nut (15/32-32 Ring).....	I-2; III-3
91046	Type Pallets.....	I-37	91721	Screw 10-32 x 3-3/4 Fil.).....	I-4
through 91054	Type Pallet.....	I-36	91744	Screw (6-40 x 13/64 Fil.).....	I-5
91055	Type Pallet.....	I-37	91746	Terminal Block.....	I-5
91056	Type Pallet.....	I-36	91753	Bracket.....	III-3
91057	Type Pallet.....	I-37	91754	Guard.....	III-3
91058	Type Pallet.....	I-37	91755	Toggle Switch.....	III-3
91059	Type Pallet.....	I-37	91761	Bracket.....	I-45; II-3
91060	Type Pallets.....	I-36	91762	Cable Assembly.....	I-45; II-3
through 91062	Type Pallets.....	I-36	91763	Cable Assembly.....	I-45; II-3
91063	Type Pallets.....	I-37	91764	Bracket.....	I-5
through 91068	Spring.....	I-12, 30	91765	Spacing Collar.....	I-5
91120	Spring Cushion Keytop.....	I-39	91766	Cable Clamp.....	I-4
91133	Spring Cushion Keytop.....	I-39	91767	Cable Clamp.....	I-4
91134	Spring Cushion Keytop.....	I-39	91768	Wire.....	I-7
91135	Platen - Rubber Covered.....	I-28	91769	Cable.....	II-4
91136	Platen - Rubber Covered.....	I-28	91770	Cable.....	II-4
91144	Spring Cushion Keytop.....	I-39	91786	Set of Parts for Relay Mounting..	I-2 IV-2
91145	Bracket.....	I-69	91787	Resistor.....	I-2
91150	Screw (10-32 x 1-9/16 Fil.).....	I-5	91789	Line Relay Cable.....	I-2; IV-2
91155	Contact Lever.....	I-65	91805	Type Pallet.....	I-36
91158	Bracket.....	I-65	91808	Spring Cushion Keytop.....	I-39
91159	Set of Parts for Remote Signal Bell Contacts.....	I-65	91809	Spring Cushion Keytop.....	I-40
91175	Roller Assembly.....	I-19	91810	Spring Cushion Keytop.....	I-39
91213	Bracket.....	I-65	91811	Spring Cushion Keytop.....	I-40
91218	Selector Mounting Plate.....	I-29, 30	91813	Type Pallet.....	I-38
91232	Type Pallet.....	I-38	91814	Type Pallet.....	I-38
91233	Type Bar (with Pallet).....	I-38	91827	Set of Parts for Converting 74839 Motor Unit to 91830.....	II-3
91234	Spring Cushion Keytop.....	I-39	91828	Set of Parts for Converting 74840 Motor Unit to 91831.....	II-3
91266	Retaining Disk.....	I-31	91830	Motor Unit.....	II-3
91273	Spring Cushion Keytop.....	I-40	91831	Motor Unit.....	II-3
91274	Spring Cushion Keytop.....	I-40	91832	Paper Spindle.....	I-57
91277	Cable.....	II-4	91850	Screw (10-32 Special).....	I-26, 28
91286	Pinion (7T).....	I-41	91851	Nut (10-32 Special).....	I-26, 28
91287	Gear (24T).....	I-41	91868	Platen - Steel Jacketed.....	I-28
91294	Spring Cushion Keytop.....	I-39	91871	Platen - Steel Jacketed.....	I-28
91507	Set of Parts for Triple Line - Feed Function.....	I-66	91873	Type Pallet.....	I-38
91509	Platen - Steel Jacketed.....	I-28	91874	Type Pallet.....	I-39
91512	Platen - Rubber Covered.....	I-28	91875	Type Pallet.....	I-38
			91876	Spring Cushion Keytop.....	I-39

Part Number	Description	Page	Part Number	Description	Page
91877	Spring Cushion Keytop.....	I-40	92529	Type Pallet.....	I-38
91878	Spring Cushion Keytop.....	I-40	92530	Spring Cushion Keytop.....	I-39
91881	Plate.....	I-53,73	92534	Test Key.....	I-13
91882	Latch.....	I-53,73	92575	Synchronous Motor.....	I-42
91883	Pawl.....	I-53,73	92687	Washer.....	I-69
91884	Plate.....	I-53	92745	Paper Chute.....	I-55,56
91885	Blocking Bail.....	I-20,53,76	92748	Screw (6-40 x 1-7/16 Fil.)...I-46	
91895	Set of Parts to Control Reperforator from Model 15 Printer.....	I-53	92784	Set of Parts to Provide End-of-Line Printing and Spacing Cutout Mechanism....	I-63
91898	Cable.....	II-4;III-3	92785	Printing Bail Latch.....	I-63
91943	Strap.....	I-45	92787	Eccentric Bushing.....	I-63
92003	Name Plate.....	II-2	92789	Bracket.....	I-63
92108	Dust Shield.....	I-33	92790	Clutch Stop.....	I-63
92109	Dust Shield.....	I-29	92793	Platen - Steel Jacketed.....	I-28
92154	Set of Parts for Converting Send-Receive-Break Mechanism from Single to Double Blank Operation.....	I-34;IV-3	92795	Platen - Steel Jacketed.....	I-28
92170	Bracket.....	I-46	92796	Platen - Rubber Covered.....	I-28
92176	Base Cable.....	I-53,73	92798	Platen - Rubber Covered.....	I-28
92180	Spring Cushion Keytop.....	I-40	92801	Type Pallet.....	I-38
92204	Cable Clamp.....	I-58	92802	Spring Cushion Keytop.....	I-39
92216	Filter.....	I-46	92819	Platen - Steel Jacketed.....	I-28
92222	Filter Assembly.....	I-46	92821	Platen - Steel Jacketed.....	I-28
92231	Set of Keytops - Spring Cushion I-39,40		92822	Spring Cushion Keytop.....	I-39
92232	Set of Parts for Converting Bell System 15E** Keyboard to 15D**.....	II-3	92823	Spring Cushion Keytop.....	I-39
92237	Cable.....	II-4	92824	Spring Cushion Keytop.....	I-40
92238	Cable.....	II-4	92854	Plug (2 Prong).....	I-9
92256	Type Pallet.....	I-37	92856	Resistor.....	I-4
92257	Type Bar (with Pallet).....	I-37	93018	Screw (4-40 Shoulder).....	I-62
92258	Spring Cushion Keytop.....	I-39	93022	Spring.....	I-62
92264	Screw (6-32 x 2-1/4 Rd.Hd.)..I-46		93073	Resistor Assembly.....	I-4
92273	Magnet Core.....	I-29	93075	Nut (15/32-32 Ring).....	I-45
92291	Capacitor.....	I-4,66	93085	Spring Cushion Keytop.....	I-39
92299	Set of Keytops - Spring Cushion I-39,40		93108	Lock Washer.....	I-17
92300	Platen - Steel Jacketed.....	I-28	93112	Screw (4-40 x 7/8 Fil.).....	I-54
92303	Platen - Steel Jacketed.....	I-28	93141	Screw (6-40 x 7/32 Fil.)..I-44,61	
92304	Platen - Rubber Covered.....	I-28	93152	Contact Spring.....	I-62
92305	Line Feed Ratchet (37T).....	I-24	93167	Reverse Arm - Left.....	I-21;IV-4
92306	Detent Ratchet (37T).....	I-24	93168	Reverse Arm - Right.....	I-21;IV-4
92308	Platen - Rubber Covered.....	I-28	93636	Resistor (100 OHMS).....	I-59
92309	Resistor.....	I-46,64	93668	Type Pallet.....	I-38
92341	Spring Cushion Keytop.....	I-40	93669	Type Pallet.....	I-38
92441	Type Pallet.....	I-39	93728	Type Bar (with Pallet).....	I-38
92442	Type Pallet.....	I-38	93730	Set of Keytops - Spring Cushion.....	I-39,40
92443	Type Pallet.....	I-39	93731	Set of Keytops - Spring Cushion.....	I-39,40
92444	Type Pallets.....	I-38	93735	Spring Cushion Keytop.....	I-40
through 92449	Type Bars (with Pallets).....	I-38	93737	Shim (.004").....	I-10
92450	Type Bars (with Pallets).....	I-38	93743	Cover Lid.....	I-47
through 92455	Shielding Tube.....	I-46	93754	Bail.....	I-20
92505	Lock Loop Roller.....	I-12	93755	Roller.....	I-20
92511			93756	Housing.....	I-20
			93757	Bearing.....	I-20
			93758	Washer - Felt.....	I-20
			93834	Glass.....	I-62
			93839	Bail Assembly.....	I-20
			93848	Paper Guide Plate.....	I-62
			93854	Synchronous Motor.....	I-42
			93875	Paper Guide.....	I-67

Part Number	Description	Page	Part Number	Description	Page
93882	Mounting Plate.....	I-46	94673	Star Wheel.....	I-63,64
93883	Capacitor Assembly.....	I-46	94674	Spring Washer.....	I-63,64
93884	Filter Assembly (Transmitting Contacts).....	I-46	94677	Retainer Plate.....	I-63
93887	Spring Cushion Keytop.....	I-39	94687	Stud.....	I-67
93894	Contact Lever Latch.....	I-65	94693	Wick.....	I-19
93915	Spring Cushion Keytop.....	I-40	94694	Wick.....	I-14
94000	Spring Cushion Keytop.....	I-39	94709	Spring.....	I-68
94009	Toggle Switch.....	I-45	94712	Washer.....	I-57
94015	Clutch Lever Bracket.....	I-30,33	95050	Power Cord.....	I-9
94073	Type Pallet.....	I-38	95052	Power Cord.....	I-9
94074	Spring Cushion Keytop.....	I-39	95063	Plug (3 Prong).....	I-9
94094	Washer - Fiber.....	I-18	95064	Plug (4 Prong).....	I-9
94226			95088	Set of Parts for Remote Signal Bell Contacts.....	I-65
through	Type Pallets.....	I-38	95089	Transformer.....	I-65
94233			95090	Chime Assembly.....	I-65
94234	Type Pallet.....	I-39	95091	Typing Unit Cable.....	I-65
94235	Type Pallet.....	I-38	95092	Base Cable.....	I-65
94240	Spiral Gear (34T).....	I-56	95102	Celluloid Keytop.....	I-40
94241	Spiral Gear (6T).....	I-56	95162	Spring Cushion Keytop.....	I-39
94242	Driving Clutch.....	I-56	95167	Spring Cushion Keytop.....	I-39
94243	Driven Clutch.....	I-56	95168	Spring Cushion Keytop.....	I-40
94248	Cable Clamp.....	I-58	95169	Spring Cushion Keytop.....	I-40
94249	Cable Clamp.....	I-58	95171	Type Pallet.....	I-38
94295	Contact Assembly.....	I-74	95172	Type Bar (with Pallet).....	I-38
94296	Contact Lever.....	I-74	95173	Spring Cushion Keytop.....	I-39
94300	Blocking Bail.....	I-76;II-1	95201	Set of Parts to Provide End-Of- Last-Form Indicating Mechanism.....	I-62
94303	Screw (6-40 Pilot).....	II-1	95210	Set of Keytops - Spring Cushion	I-39,40
94401	Type Pallet.....	I-38	95213	Set of Parts for Spark Protection.....	I-64
94406	Type Pallet.....	I-38	95214	Set of Parts for Spark Protection.....	I-64
94411	Type Pallet.....	I-38	95216	Set of Parts to Provide Electrical Word and Operations Counter for Use with A.C.....	I-64
94468	Type Pallet.....	I-38	95217	Set of Parts to Provide Electrical Word and Operations Counter for Use with D.C.....	I-64
94490	Series - Parallel Switch Assembly I-31;II-4;III-3;IV-2		95238	Resistor.....	I-64
94496	Spring Cushion Keytop.....	I-40	95239	Screw (2-56 Special).....	I-64
94616	Set of Parts for Instruction Card Holder.....	I-68	95240	Cover.....	I-64
94617	Spacer.....	I-49,68;III-2	95241	Contact Spring.....	I-64
94622	Set of Parts to Provide Sprocket Feed Tearing Edge Mounted on the Typing Unit.....	I-61	95242	Bracket.....	I-64
94623	Arm - Left.....	I-61	95243	Shaft.....	I-64
94624	Screw (6-40 x 1-1/8 Fil.).....	I-61	95244	Bearing Block.....	I-64
94625	Arm - Right.....	I-61	95246	Cable.....	I-64
94626	Spacing Collar.....	I-61	95247	Bushing.....	I-64
94627	Bracket.....	I-61	95248	Bracket.....	I-64
94628	Screw (10-32 x 7/8 Rd.Hd.).....	I-61	95249	Plate Insulator.....	I-64
94629	Blade.....	I-61	95302	Screw (6-40 x 1-3/4 Flat Hd.).....	I-64
94630	Paper Guide.....	I-61	95303	Bushing.....	I-64
94648	Spring Cushion Keytop.....	I-40	95316	Detent Lever.....	I-69
94663	Set of Parts for Mechanical Word Counter.....	I-63	95317	Set of Parts to Apply Signal Distortion Prevention Detent....	I-69
94664	Support - Right.....	I-63,64	95320	Toggle Switch.....	I-2
94665	Screw (6-40 Shoulder).....	I-63,64			
94666	Lever.....	I-63,64			
94668	Bell Crank.....	I-63,64			
94669	Screw (4-40 Shoulder).....	I-63,64			
94670	Lever.....	I-63,64			
94671	Bracket.....	I-63,64			

Part Number	Description	Page	Part Number	Description	Page
95380	Set of Parts Converting a Typing Unit with a Pulling Magnet Selector to a Typing Unit with a Holding Magnet Selector.....	I-29	97381	Plunger.....	I-70
95636	Screw (6-40 Special).....	I-52	97382	Carriage Track.....	I-70
95774	Post.....	I-66	97384	Type Bar Guide.....	I-70
95935	Insulator.....	I-44	97388	Bracket.....	I-70
95936	Choke Coil.....	I-44	97389	Link.....	I-70
95937	Capacitor.....	I-44, 46	97390	Bar.....	I-70
95938	Capacitor.....	I-44, 46	97391	Screw (4-40 Shoulder).....	I-70
96117	Wire.....	I-4	97392	Armature Lever.....	I-70
96208	Wire.....	I-7	97394	Screw (6-40 Shoulder).....	I-70
96258	Wire.....	I-2	97396	Magnet Yoke.....	I-70
96261	Wire.....	I-2	97397	Armature.....	I-70
96276	Strap.....	I-71	97399	Bracket.....	I-71
96493	Spring Cushion Keytop.....	I-40	97400	Spacer.....	I-71
96522	Spring Cushion Keytop.....	I-40	97401	Link.....	I-71
96523			97402	Screw (6-40 Shoulder).....	I-71
through	Spring Cushion Keytops.....	I-39	97403	Contacting Operating Lever.....	I-71
96526			97404	Latch.....	I-70
96527			97405	Send-Receive Lever.....	I-71
through	Spring Cushion Keytops.....	I-40	97406	Latch.....	I-71
96531			97407	Lever.....	I-70
96532	Spring Cushion Keytop.....	I-39	97408	Oscillator.....	I-70
96533	Spring Cushion Keytop.....	I-39	97409	Spacer.....	I-71
96534	Spring Cushion Keytop.....	I-40	97410	Bracket.....	I-70
96535	Set of Gears.....	I-41	97411	Plate.....	I-70
96536	Set of Gears.....	I-41	97412	Bracket.....	I-71
96545			97413	Contact Assembly.....	I-71
through	Type Pallets.....	I-38	97420	Cable.....	I-71
96548			97600	Ribbon Carrier.....	I-70
96549			97604	Set of Parts for Operation on "Blank" Selection.....	II-2
through	Type Pallets.....	I-39	97621	Contact Assembly.....	II-2
96554			97622	Contact Spring.....	II-2
96555	Type Pallet.....	I-38	97626	Cable.....	II-2
96556	Type Pallet.....	I-38	97645	Set of Parts for Upper Case "H" Contact Mechanism.....	I-7, 8
96557	Type Pallet.....	I-39	97646	Set of Parts for Motor Control...	I-8
96558	Type Pallet.....	I-38	97648	Strap.....	I-71
96559	Type Pallet.....	I-37	97649	Spring Cushion Keytop.....	I-39
96598	Spring Cushion Keytop.....	I-39	97675	Draw Strap.....	I-18
96599	Spring Cushion Keytop.....	I-40	97852	Celluloid Keytop.....	I-40
96763	Shim (.012").....	IV-1	97924	Type Pallet.....	I-38
96764	Shim (.016").....	IV-1	97925	Type Pallet.....	I-38
96765	Shim (.020").....	IV-1	97926	Type Bar (with Pallet).....	I-38
96807	Set of Parts to Control Reperforator from Model 15 Printer.....	I-53	97927	Type Bar (with Pallet).....	I-38
96822	Function Lever.....	I-35	97928	Spring Cushion Keytop.....	I-39
96883	Terminal.....	I-10, 58, 66	97929	Spring Cushion Keytop.....	I-39
96892	Set of Parts for Upper Case "H" Electrical Motor Control.....	I-8	98049	Spring Cushion Keytop.....	I-39
96893	Motor Stop Assembly.....	I-8	98351	Spring Cushion Keytop.....	I-39
96894	Bracket.....	I-7	98379	Type Bar (with Pallet).....	I-38
96895	Cable.....	I-7	98387	Sending Contact Spark Protection (Wave Shaper).....	I-4
97117	Ribbon: Red-Black.....	I-70	98465	Set of Type Pallets Murray Style.....	I-36
97203	Spring Cushion Keytop.....	I-40	98492	Function Lever.....	I-35
97292	Link.....	I-29	98497	Celluloid Keytop.....	I-40
97306	Lock Washer.....	I-16	98499	Celluloid Keytop.....	I-40
97317	Clamping Plate.....	I-29	98500	Celluloid Keytop.....	I-40
97380	Type Bar Basket.....	IV-2	98833	Screw (4-40 x 31/32 Fil.).....	I-7
			98893	Spring Cushion Keytop.....	I-40
			99038	Type Pallet.....	I-39

Part Number	Description	Page	Part Number	Description	Page
99039	Type Pallet.....	I-38	99535	Spring Cushion Keytop.....	I-39
99040	Type Pallet.....	I-38	99538	Spring Cushion Keytop.....	I-40
99041	Spring Cushion Keytop.....	I-39	99543	through Spring Cushion Keytops.....	I-39
99042	Spring Cushion Keytop.....	I-40	99545	99549	Spring Cushion Keytop.....
99043	Spring Cushion Keytop.....	I-40	99549	Spring Cushion Keytop.....	I-40
99112	Function Lever.....	I-35	99551	Spring Cushion Keytop.....	I-40
99163	Type Pallet.....	I-38	99556	through Spring Cushion Keytops.....	I-39
99164	Type Pallet.....	I-38	99558	99559	Spring Cushion Keytop.....
99165	Type Pallet.....	I-38	99559	Spring Cushion Keytop.....	I-40
99166	Type Bar (with Pallet).....	I-38	99560	Spring Cushion Keytop.....	I-40
99167	Type Bar (with Pallet).....	I-38	99561	Spring Cushion Keytop.....	I-39
99168	Type Bar (with Pallet).....	I-38	99562	Spring Cushion Keytop.....	I-39
99169	Spring Cushion Keytop.....	I-40	99564	Spring Cushion Keytop.....	I-40
99175	Spring Cushion Keytop.....	I-39	99566	Spring Cushion Keytop.....	I-39
99188	Type Pallet.....	I-38	99568	Spring Cushion Keytop.....	I-39
99189	Type Pallet.....	I-38	99569	Spring Cushion Keytop.....	I-39
99190	Spring Cushion Keytop.....	I-39	99574	Spring Cushion Keytop.....	I-39
99197	Type Pallet.....	I-38	99575	Spring Cushion Keytop.....	I-39
99198	Type Bar (with Pallet).....	I-38	99578	Spring Cushion Keytop.....	I-39
99199	Spring Cushion Keytop.....	I-40	99579	Spring Cushion Keytop.....	I-40
99210	Spring Cushion Keytop.....	I-40	99589	Spring Cushion Keytop.....	I-40
99211	Celluloid Keytop.....	I-40	99593	Spring Cushion Keytop.....	I-39
99250	Filter Assembly.....	I-44	99629	Spring Cushion Keytop.....	I-40
99354	Container.....	I-44	99632	Spring Cushion Keytop.....	I-39
99355	Bracket.....	I-44	99676	Celluloid Keytop.....	I-40
99356	Bracket.....	I-44	99677	Celluloid Keytop.....	I-40
99357	Retaining Strap.....	I-44	99689	Celluloid Keytop.....	I-40
99440	Platen - Rubber Covered.....	I-28	99698	Celluloid Keytop.....	I-40
99447	Spring Cushion Keytop.....	I-39	99700	through Celluloid Keytops.....	I-40
99450	Spring Cushion Keytop.....	I-39	99704	99737	Screw (6-40 x 13/64 Fil.).....
99452	Spring Cushion Keytop.....	I-40	99737	99744	Resistor.....
99458	Platen - Rubber Covered.....	I-28	99744	99745	Line and Selector Jack.....
99502	Modification Kit for Two-Color Printing.....	I-70,71	99745	99802	Retainer Plate.....
99503	Template.....	I-70	99802	99803	Insulator.....
99504	Type Pallet.....	I-39	99803	99804	Insulator.....
99505	through Type Pallets.....	I-38	99804	99805	Plunger.....
99507	99508	Type Pallet.....	99805	99806	Bracket.....
99508	Type Pallet.....	I-39	99806	99807	Contact Spring.....
99509	Type Pallet.....	I-39	99807	99809	Contact Spring.....
99510	through Type Pallets.....	I-38	99809	99816	Relay Base.....
99515	99516	Type Pallet.....	99816	99817	Foot - Metal.....
99516	Type Pallet.....	I-39	99817	99818	Clamp.....
99517	through Type Pallets.....	I-38	99818	99897	Shaft.....
99519	99520	Type Pallet.....	99897	99898	Screw (6-40 Special).....
99519	Type Pallet.....	I-39	99898	99939	Ring.....
99520	Type Pallet.....	I-38	99939	99959	Cord Clamp.....
99521	Type Pallet.....	I-38	99959	100565	Screw (6-40 x 3/4 Hex).....
99522	Type Pallet.....	I-38	100565	100759	Screw (4-40 x 3/16 Flat).....
99523	Type Pallet.....	I-38	100759	101003	Jewel - Amber.....
99524	Type Pallet.....	I-39	101003	101384	Set of Parts for Upper Case "H" Contact Mechanism.....
99525	through Type Pallets.....	I-38	101384	101419	Mechanical Counter.....
99527	99528	Type Pallet.....	101419	101456	Screw (6-32 x 9/32 Rd. Hd.).....
99527	Type Pallet.....	I-39	101456		58,66
99528	through Type Pallets.....	I-38		101470	Plug.....
99529	99533	Spring Cushion Keytop.....	101470	101538	Handwheel.....
99529	Spring Cushion Keytop.....	I-40	101538		I-73

Part Number	Description	Page	Part Number	Description	Page
101584	Type Bar (with Pallet).....	I-38	103286	Fusetron - 1.6 Amp.....	I-1
101597	Function Lever.....	II-1	103289	Fusetron - 0.8 Amp.....	I-1
101598	Contact Lever.....	II-1	103300	Function Lever.....	I-35
101748	Type Bar.....	I-38	103323	Washer.....	I-61
101749	Blocking Bail.....	I-20,69,76	103440	Set of Parts to Provide for Printing and Spacing on Blank and Other Functions....	I-69
101750	Type Bar (with Pallet)....	I-38,69	103527	Pressure Roller Lever.....	I-55
101751	Type Bar (with Pallet)....	I-38,69	103528	Pressure Roller Lever.....	I-55
101752	Type Bar (with Pallet)....	I-38,69	103628	Speed Indicator.....	I-41
101757	Contact Spring.....	II-1	103746	Resistor.....	I-5;IV-1
101758	Contact Spring.....	II-1	103933	Type Pallet.....	I-38
101760	Contact Assembly.....	II-1	103934	Type Pallet.....	I-38
101808	Shim (.004").....	I-60	103975	Window.....	I-47
101919	Operating Lever.....	II-1	104068	Repeat Lever Yoke.....	I-58
101920	Contact Lever.....	II-1	104075	Type Pallet.....	I-36
101921	Universal Contact and Bracket Assembly.....	II-1	104084	Blocking Bail.....	I-20,76
101922	Bracket.....	II-1	104206	Set of Parts to Provide Connection on Base for Typing Units with Switching Contacts.....	II-1
101923	Contact Spring.....	II-1	104243	Spacer Bar Shaft.....	I-58
101927	Contact Spring.....	II-1	104244	Repeat Rod.....	I-58
101928	Function Lever.....	II-1	104246	Spacer Bar Loop.....	I-58
101929	Bracket.....	II-1	104300	Hub.....	I-73
101930	"Figures" Contact and Bracket Assembly.....	II-1	104301	Block.....	I-73
102014	Cover.....	II-1	104302	Pin.....	I-73
102015	Cable.....	II-1	104451	Lock Washer.....	I-19,43
102049	Cable.....	II-1	104473	Pressure Roller Bushing..	I-56;IV-2
102100	Terminal.....	I-9	104521	Handwheel Assembly.....	I-73
102171	Shelf.....	I-67	104572	Arm.....	I-47;IV-3
102369	Platen - Steel Jacketed.....	I-28	104666	Set of Parts for Cam Operated Contacts.....	I-66
102372	Platen - Steel Jacketed.....	I-28	104687	Contact Spring.....	I-66
102671	Contact Spring.....	II-1	104688	Guard.....	I-66
102672	Contact Spring.....	II-1	104697	Cable.....	I-66
102673	Contact Spring.....	II-1	104698	Wire.....	I-66
102721	Shelf.....	I-67	104731	Housing.....	I-63
102820	Strap.....	I-66	104824	Spring.....	I-17
102821	Set of Parts to Provide 1/10 MF Capacitor Across Upper Case "H" Motor Control Contacts...I-66		104990	Glass.....	I-47
102874	Filter Assembly (Power Leads)	I-46	104995	Pin.....	I-24;IV-2
102907	Spool Retainer.....	I-21	105029	Collar.....	I-24;IV-2
102914	Bracket.....	I-46	105048	Set of Parts for Lubricating Model 15 Printer Main Shaft...I-16	
102915	Insulator.....	I-46	105149	Extension Lever.....	I-58
102916	Bracket.....	I-46	105221	Contact Spring.....	I-3
102917	Insulator.....	I-46	105222	Contact Spring.....	I-3
102918	Terminal Block.....	I-46	105223	Contact Spring.....	I-3
102940	Ground Wire.....	I-46	105274	Function Lever.....	I-35,54
102946	Filter.....	I-46	105333	Type Pallet.....	I-38
102982			105337	Type Pallet.....	I-38
through	Type Bars (with Pallets)....	I-38	105338	Type Pallet.....	I-38
102984			105343	Type Pallet.....	I-36
102985	Type Bar (with Pallet).....	I-37	105381	Blocking Bail.....	I-54,76
102986			105912	Lock Washer.....	I-45
through	Type Bars (with Pallets)....	I-38	105940	Stiffener.....	I-58
102991			105960	Screw (6-40 x 41/64 Hex)....	I-58
103169	Type Pallet.....	I-39	106038	Blocking Bail.....	I-20,54,76
103170	Type Pallet.....	I-39	106039	Set of Parts to Adapt a Mech. Motor Control to Operate on Shift-Blank-Stop.....	I-56
103171	Type Pallet.....	I-38			
103236	Plug - Black.....	I-9			
103284	Fusetron - 3.2 Amp.....	I-1			

Part Number	Description	Page	Part Number	Description	Page
106140	Guide Plate.....	I-54	110761	Signal Bell.....	I-65;III-1
106141	Lever.....	I-54	110762	Signal Bell.....	I-65;III-1
106142	Bell Crank Retainer.....	I-54	110763	Signal Bell.....	I-65;III-1
106143	Trip Lever.....	I-54	110908		
106144	Function Lever.....	I-35,54	through	Type Pallets.....	I-38
106145	Function Lever.....	I-35	110911		
106146	Bail.....	I-54	110912		
106148	Extension.....	I-54	through	Type Bars (with Pallets).....	I-38
106150	Mounting Plate.....	I-54	110915		
106244	Resistor.....	I-5,31	110920	Guide Rod.....	I-49;III-2
106245	Resistor.....	I-31	110921	Guide Rod.....	I-49
106279	Function Lever.....	I-35,54	110980	Filler - Fiber.....	I-61
106852	Retainer Plate.....	I-54	110983	Clamp - Rear.....	I-61
106855	Screw (4-40 Eccentric Shoulder)	I-54	110984	Clamp - Front.....	I-61
			110985	Glass - Rear.....	I-61
106938	Set of Parts to Convert Test Key from Push Type to Cam Type.....	I-13	110986	Glass - Front.....	I-61
106939	Set of Parts to Provide Spacing for 8 Characters per Inch....	I-69	111003	Receptacle.....	I-58
106968	Set of Parts to Provide for 84 Characters per Line or 11-2/3 Characters per Inch	I-69	111015	Function Lever.....	I-35
107112	Shim (.002").....	I-11	111017	Screw (6-40 x 5/16 Fil.)....	I-56,69 IV-4
107137	Shield.....	I-27	111027	Buffer Lever Block.....	I-14
107141	Dust Shield.....	I-22;III-3	111182	Set of Parts for Converting Bell System 15F** Keyboard to 15G** (Set of Keytops - Spring Cushion).....	I-39,40;II-3
107159	Set of Type Pallets (Weather Map Service).....	I-37;IV-3	111253	Cord - Nylon.....	I-61
107160	Set of Parts to Convert to Weather Map Service.....	IV-3	111259	Hook.....	I-61
107174	Paper Stripper.....	I-27;IV-2	111262	Bracket.....	I-13
107176	Set of Type Pallets - Murray Style.....	I-36	111303	Container.....	I-46
107213	Bracket.....	I-2	111329	Line Guide.....	I-49
107269	Polar-Neutral Toggle Switch....	I-2	111365	Type Pallet.....	I-38
107273	Spring - Left.....	I-21	111366	Type Pallet.....	I-39
107274	Spring - Right.....	I-21	111367	Type Pallet.....	I-39
107458	Spring.....	I-61	111448	Type Pallet.....	I-37
107460	Gear (20T).....	I-41	111516	Washer.....	I-74
107461	Pinion (7T).....	I-41	111654	Pad - Felt.....	I-47
107474	Set of Gears.....	I-41	111713	Screw (2-56 x 5/32 Flat Hd.)....	III-3
107485	Screw (6-40 Eccentric Shoulder).....	I-12;IV-1	111736	Type Pallet.....	I-38
107487	Container.....	I-21	111737	Type Pallet.....	I-38
107488	Container.....	I-21	111738	Type Pallet.....	I-39
107491	Screw (10-32 x 1 Flat Hd.)....	I-3	111739	Type Pallet.....	I-39
109770	Terminal Block.....	I-31	111740	Type Pallet.....	I-38
109889	Screw (3-56 x 1/4 Flat Hd.)....	I-13	111741	Type Pallet.....	I-38
110350	Spring Block.....	I-21	111742	Type Pallet.....	I-39
110351	Backstop.....	I-21	111743	Type Pallet.....	I-39
110352	Set of Parts for Ribbon Reverse Arm, Yield Spring and Backstop	I-21;IV-4	111744	Type Pallet.....	I-38
110434	Screw (4-40 x 3/16 Fil.)....	I-44	111745	Type Pallet.....	I-38
110435	Nut (4-40 Hex)....	I-2,12,17,24,31 32,47,50,53,54,63,64,73,74	111746	Type Pallet.....	I-39
110437	Spring.....	I-3,63	111747		
110440	Pin.....	I-52	through	Type Pallets.....	I-38
110743	Lock Washer.....	I-31,69	111752		
			111753	Type Pallet.....	I-39
			111754	Type Pallet.....	I-38
			111755	Type Pallet.....	I-39
			111756	Type Pallet.....	I-38
			111757	Type Pallet.....	I-39
			111758	Type Pallet.....	I-38
			111759	Type Pallet.....	I-39

Part Number	Description	Page	Part Number	Description	Page
111760	Type Pallet.....	I-39	113675	Set of Parts for Independently Operated Paper Fingers.....	I-60
111761			113699	Paper Guide Roller Shaft Assembly.....	I-55
through 111764	Type Pallets.....	I-38	113700	Set of Parts for Two-Color Ribbon Printer Equipped with Reperforator Control.....	I-75
111765	Type Pallet.....	I-39	113703	Terminal Block Assembly (Series-Parallel)...I-31;II-4;IV-2	
111766	Type Pallet.....	I-39	113704	Terminal Block Assembly...I-31;IV-2	
111970	Cam Key.....	I-13	113749	Modification Kit to Convert Bell System Keyboard from Arrangement "A" to "D".....	I-40
111987	Type Pallet.....	I-38	113761	Set of Parts to Provide "H" Suppression on Keyboards.....	I-69
111988	Type Pallet.....	I-39	113780	Set of Parts for Printer Having Excessive Wear on Side Frame..	I-74
111989	Type Pallet.....	I-39	113790	Set of Parts to Provide Tear-off Edge for Short Forms.....	I-62
111990	Type Pallet.....	I-38	113872	Eccentric Bushing.....	I-19;IV-1
111991	Type Pallet.....	I-38	113892	Bracket.....	I-44
111992			113951	Filter Assembly.....	I-44
through 111994	Type Pallets.....	I-39	114069	Base Plate.....	I-1
111995	Type Pallet.....	I-38	114125	Screw (6-40 x 3/8 Hex).....	I-23
111996			114139	Bell Crank.....	I-19;IV-1
through 111998	Type Pallets.....	I-39	114240	Copyholder Plate.....	I-49
111999	Type Pallet.....	I-38	114321	Synchronous Motor.....	I-42
112000	Type Pallet.....	I-39	114322	Capacitor.....	I-42
112001	Type Pallet.....	I-39	114323	Capacitor.....	I-42
112002	Type Pallet.....	I-38	114324	Bracket.....	I-42
112003	Type Pallet.....	I-38	114432	Code Bar.....	I-19,36;IV-1
112016	Type Pallet.....	I-39	114437	Knob.....	I-63
112127	Cam Follower Hinge.....	I-58	114477	Shelf.....	I-67
112128	Cam Follower Retainer.....	I-58	114515	Set of Keytops-Spring Cushion.....	I-39,40
112549	Set of Parts to Provide Local Test on Keyboard.....	I-13	114518	Link.....	I-63,64
112571	Contact Spring.....	I-58	114519	Eccentric Spring Post.....	I-63,64
112572	Contact Spring.....	I-58	114520	Arm.....	I-56
112578	Plate.....	I-58	114521	Arm.....	I-56
112621	Screw (4-40 Shoulder).....	I-22;III-3	114627	Type Pallet.....	I-38
112626	Nut (10-32 Hex).I-1,2,14,15,18,19,20,22,23,24,32,34,41,42,43,51,52,61,65;II-1		114628	Type Pallet.....	I-38
112627	Nut (2-56 Hex)...I-32,48,52,58,60,61		114629	Type Pallet.....	I-39
112631	Spring.....	I-58	114657	Spring.....	I-25,55,56;IV-2
112634	Spring.....	I-11	114717	Rail.....	I-1
112670	Local Test Key.....	I-13	114748	Backstop Assembly.....	III-1
112699	Screw (6-40 Set).....	I-24	114749	Cable.....	I-13;II-4
113250	Spring Cushion Keytop.....	I-39	114785	Type Bar (with Pallet).....	I-37
113251	Spring Cushion Keytop.....	I-39	114786	Type Bar (with Pallet).....	I-38
113252	Spring Cushion Keytop.....	I-40	114788		
113259	Spring Cushion Keytop.....	I-40	through	Type Bars (with Pallets).....	I-38
113296	Spring Cushion Keytop.....	I-39	114794		
113309	Spring Cushion Keytop.....	I-39	114826	Type Bar (with Pallet).....	I-37
113310			114829		
through 113312	Spring Cushion Keytops.....	I-40	through	Type Bars (with Pallets).....	I-37
113316	Spring Cushion Keytop.....	I-40	114832		
113317	Spring Cushion Keytop.....	I-40	114835	Type Bar (with Pallet).....	I-37
113318	Spring Cushion Keytop.....	I-39	114836	Type Bar (with Pallet).....	I-37
113327	Spring Cushion Keytop.....	I-39	114838	Type Bar (with Pallet).....	I-36
113329	Spring Cushion Keytop.....	I-39	114839	Type Bar (with Pallet).....	I-37
113345	Spring Cushion Keytop.....	I-40	114840	Type Bar (with Pallet).....	I-36
113348	Spring Cushion Keytop.....	I-40	114842	Type Bar (with Pallet).....	I-37
113660	Set of Parts to Provide Switching Contacts on BP99 and BP105.II-1				

Part Number	Description	Page	Part Number	Description	Page
114843	Type Bar (with Pallet).....	I-36	115751	Set of Parts for Communication Service.....	I-54
114846	Type Bar (with Pallet).....	I-37	115752	Set of Parts for Weather Service.....	I-54
114847	Type Bar (with Pallet).....	I-37	115765	Form Accumulating Shelf.....	I-67
114849	Type Bar (with Pallet).....	I-37	115766	Form Accumulating Shelf.....	I-67
114850	Type Bar (with Pallet).....	I-37	115769	Sprocket Feed Tearing Edge Assembly.....	I-61
114857	Set of Type Bars with Pallets - Large Gothic Style.....	I-36, 56, 69	115790	Single Pressure Roller on Platen Parts.....	I-55; IV-4
114861	Type Bar (with Pallet).....	I-37	115823	Type Bar Backstop Assembly....	I-22
114862	Type Bar (with Pallet).....	I-37	115842	Type Bar Backstop Assembly (with Dust Shield).....	I-22
114863	Type Bar (with Pallet).....	I-36	115847	End-of-Last-Form Indicating Mechanism.....	I-60
114864	Type Bars (with Pallets).....	I-37	115872	Set of Parts to Convert Typing Unit.....	I-27
through 114867	Type Bars (with Pallets).....	I-37	115889	Control Reperforator from Model 15 Printer.....	I-73
114868	Type Bar (with Pallet).....	I-36	116709	Bracket.....	I-44
114869	Type Bar (with Pallet).....	I-36	116714	Function Lever.....	I-35
114870	Type Bar (with Pallet).....	I-37	116761	Post.....	I-56, 69
114890	Celluloid Keytops.....	I-40	116769	Blocking Bail.....	I-20, 73, 76
through 114894	Celluloid Keytop.....	I-40	116793	Lock Washer.....	I-26, 57
114897	Celluloid Keytop.....	I-40	116965	Function Lever.....	I-35, 53, 73, 74
114908	Celluloid Keytop.....	I-40	116992	Screw (1/4-32 Pilot).....	I-43
114919	Celluloid Keytop.....	I-40	117079	Rail - Right.....	I-62
114921	Celluloid Keytop.....	I-40	117080	Rail - Left.....	I-62
114958	Signal Lamp Cover.....	I-58	117141	Type Pallet.....	I-39
114959	Signal Lamp.....	I-58	117142	Type Pallet.....	I-39
114965	Filter Assembly (Line Relay)...	I-46	117143	Type Pallet.....	I-38
114967	Bracket.....	I-46	117145	Type Pallet.....	I-39
114992	Celluloid Keytop.....	I-40	117146	Type Pallet.....	I-38
115299	Terminal Strip.....	I-59	117147	Type Pallet.....	I-39
115542	Function Lever.....	I-35	117148	Type Pallet.....	I-38
115586	Cable.....	I-45	117149	Type Pallet.....	I-39
115620	Type Pallet.....	I-37	117150	Type Pallet.....	I-38
115621	Type Pallet.....	I-36	117151	Type Pallets.....	I-39
115622	Type Pallets.....	I-37	through 117157	Type Pallet.....	I-38
through 115627	Type Pallet.....	I-36	117158	Type Pallet.....	I-38
115628	Type Pallet.....	I-36	117197	Cover Lid (to Accommodate Paper Winder).....	I-47
115629	Type Pallets.....	I-38	117235	Set of Type Pallets - Gothic Style.....	I-36
through 115633	Type Pallet.....	I-39	117236	Type Pallet.....	I-37, 39
115634	Type Pallet.....	I-38	117237	Type Pallet.....	I-36, 38
115635	Type Pallet.....	I-39	117238	Type Pallet.....	I-37, 39
115636	Type Pallet.....	I-38	117239	Type Pallet.....	I-37, 39
115637	Type Pallet.....	I-39	117240	Type Pallet.....	I-36, 38
115638	Type Pallet.....	I-38	117241	Type Pallet.....	I-37, 39
115639	Type Pallet.....	I-39	117242	Type Pallet.....	I-37, 39
115640	Type Pallet.....	I-38	117243	Type Pallet.....	I-39
115641	Type Pallet.....	I-39	117244	Type Pallet.....	I-38
115642	Type Pallet.....	I-38	117245	Type Pallet.....	I-38
115643	Type Pallet.....	I-39	117246	Type Pallet.....	I-39
115644	Type Pallet.....	I-38	117247	Type Pallet.....	I-39
115700	Copyholder Assembly.....	I-49	117248	Type Pallet.....	I-38
115704	Cover Plate - Front.....	I-48	117249	Type Pallet.....	I-39
115706	Cover Plate - Front.....	I-48			
115709	Copyholder Assembly.....	I-49			
115715	Cover Plate - Front.....	I-48			
115721	Cover Plate - Front.....	I-48			
115723	Form Accumulating Shelf.....	I-67			
115740	Glare Shield.....	I-61			

Part Number	Description	Page	Part Number	Description	Page
117258	Push Button Key.....	I-58	118011		
117306	Cover Plate - Front.....	I-48	through	Spring Cushion Keytops.....	I-40
117313	Adjustable Spindle.....	I-26;IV-2	118014		
117314	Spring.....	I-26,57;IV-4	118015	Spring Cushion Keytop.....	I-39
117315	Hub.....	I-26	118017	Spring Cushion Keytop.....	I-40
117316	Hub.....	I-26	118018	Spring Cushion Keytop.....	I-40
117317	Stud.....	I-26,57	118019	Spring Cushion Keytop.....	I-39
117318	Screw (6-32 x 1/4 Fil.)....	I-26,57	118020	Spring Cushion Keytop.....	I-39
117319	Shaft.....	I-26,57	118028	Spring Cushion Keytop.....	I-40
117407	Contact Spring.....	I-65	118034	Spring Cushion Keytop.....	I-40
117408	Contact Spring.....	I-7	118035		
117409	Mounting Plate.....	I-7	through	Type Pallets.....	I-38
117410	Cable.....	I-7	118037		
117434	Cover Door.....	I-47	118038	Type Pallet.....	I-39
117745	Set of Parts for Upper Case "H" Electric Motor Control.....	I-7	118039		
117746	Set of Parts for Motor Control.....	I-7	through	Type Pallets.....	I-38
117747	Motor Stop Assembly.....	I-7	118041		
117907	Shield.....	I-67	118042	Type Pallet.....	I-39
117931	Mounting Bracket.....	I-67	118043	Type Pallet.....	I-38
117936	Spring Cushion Keytop.....	I-40	118044	Type Pallet.....	I-39
117939	Spring Cushion Keytop.....	I-40	118045		
117940	Spring Cushion Keytop.....	I-39	through	Type Pallets.....	I-38
117943	Spring Cushion Keytop.....	I-39	118047		
117948	Spring Cushion Keytop.....	I-39	118048	Type Pallet.....	I-39
117949	Spring Cushion Keytop.....	I-39	118049	Type Pallet.....	I-39
117950	Spring Cushion Keytop.....	I-40	118052	Type Pallet.....	I-38
117951	Spring Cushion Keytop.....	I-39	118053	Type Pallet.....	I-39
117952	Spring Cushion Keytop.....	I-40	118054		
117954	Spring Cushion Keytop.....	I-39	through	Type Pallets.....	I-38
117955	Spring Cushion Keytop.....	I-39	118062		
117957	Spring Cushion Keytop.....	I-40	118063	Type Pallet.....	I-39
117967	Spring Cushion Keytop.....	I-40	118064	Type Pallet.....	I-38
117970	Spring Cushion Keytop.....	I-39	118065	Type Pallet.....	I-39
117971	Spring Cushion Keytop.....	I-40	118066	Type Pallet.....	I-39
117972			118067	Type Pallet.....	I-38
through	Spring Cushion Keytops.....	I-39	118068	Type Pallet.....	I-38
117977			118069	Type Pallet.....	I-39
117978			118070	Type Pallet.....	I-38
through	Spring Cushion Keytops.....	I-40	118071	Type Pallet.....	I-39
117981			118072	Type Pallet.....	I-38
117982	Spring Cushion Keytop.....	I-39	118073	Type Pallet.....	I-38
117983	Spring Cushion Keytop.....	I-40	118074		
117984	Spring Cushion Keytop.....	I-39	through	Type Pallets.....	I-39
117985	Spring Cushion Keytop.....	I-40	118076		
117989	Spring Cushion Keytop.....	I-39	118077	Type Pallet.....	I-38
117990	Spring Cushion Keytop.....	I-39	118078	Type Pallet.....	I-39
117991	Spring Cushion Keytop.....	I-40	118079	Type Pallet.....	I-39
117992	Spring Cushion Keytop.....	I-40	118081	Type Pallet.....	I-38
117994	Spring Cushion Keytop.....	I-40	118082	Type Pallet.....	I-38
117995	Spring Cushion Keytop.....	I-39	118083	Type Pallet.....	I-39
117996	Spring Cushion Keytop.....	I-39	118084	Type Pallet.....	I-39
117999	Spring Cushion Keytop.....	I-40	118265	Platen - Rubber Covered.....	I-28
118000	Spring Cushion Keytop.....	I-39	118267	Platen - Rubber Covered.....	I-28
118001	Spring Cushion Keytop.....	I-39	118281	Spacing Gear - Upper.....	I-69
118002	Spring Cushion Keytop.....	I-40	118282	Rack.....	I-69
118003	Spring Cushion Keytop.....	I-39	118484	Function Lever.....	I-35
118005	Spring Cushion Keytop.....	I-40	118485	Cover Plate.....	I-48
118010	Spring Cushion Keytop.....	I-39	118491	Blocking Bail.....	I-76

Part Number	Description	Page	Part Number	Description	Page
118836	Set of Type Pallets - Long Gothic Style.....	I-36	120021	Type Pallet.....	I-38
118837	Set of Type Pallets - Long Gothic Style.....	I-36	120023	Type Pallet.....	I-38
119180 through 119182	Type Pallets.....	I-39	120024	Type Pallet.....	I-39
119183	Type Pallet.....	I-38	120025	Type Pallet.....	I-38
119184	Type Pallet.....	I-38	120026	Type Pallet.....	I-38
119185	Type Pallet.....	I-39	120027	Type Pallet.....	I-39
119186	Type Pallet.....	I-39	120028	Type Pallet.....	I-38
119187	Type Pallet.....	I-39	120029	Type Pallet.....	I-38
119188	Type Pallet.....	I-38	120031	Type Pallet.....	I-39
119189 through 119198	Type Pallets.....	I-39	120033	Type Pallets.....	I-39
119199	Type Pallet.....	I-38	120035	Type Pallet.....	I-38
119200	Type Pallet.....	I-39	120036	Type Pallet.....	I-38
119201	Type Pallet.....	I-38	120037	Type Pallets.....	I-39
119202	Type Pallet.....	I-38	120039	Type Pallet.....	I-38
119203 through 119206	Type Pallets.....	I-39	120040	Type Pallet.....	I-38
119207	Type Pallet.....	I-38	120041	Type Pallet.....	I-38
119235	Insulator.....	I-68	120042	Type Pallet.....	I-39
119465	Switch.....	I-58	120049	Type Pallet.....	I-39
119467	Insulator.....	I-52	120052	Type Pallet.....	I-39
119468	Collar.....	I-68	120053	Type Pallet.....	I-38
119469	Mounting Plate.....	I-68	120054	Type Pallet.....	I-39
119470	Arm.....	I-68	120055	Type Pallet.....	I-39
119471	Switch Assembly.....	I-68	120056	Type Pallet.....	I-38
119474	Screw (4-40 Special).....	I-68	120057	Type Pallets.....	I-39
119486	Bracket.....	I-68	120061	Resistor (330 OHMS).....	I-59
119488	Switch Operating Bracket.....	I-58	120452	Code Plate.....	II-2,3,4
119534	Oil Wick.....	I-22	120453	Code Plate.....	II-2,3,4
119540	Keyed Nut.....	I-16;IV-1	120456	Code Plate.....	II-3,4
119629	Link.....	I-31,32	120460	Code Plate.....	II-3,4
119652	Retaining Ring.....	I-52	120490	Type Pallet.....	I-38
119654	Retaining Ring.....	I-52	120498	Retainer.....	I-47
119759	Cable Assembly.....	I-68	120575	Type Bar Bracket.....	I-22
119858	Cable.....	I-58	120593	Blade.....	I-61
119860	Switch Mounting Bracket.....	I-58	120683	Function Lever.....	I-35
119861	Key Lever.....	I-58	120684	Function Lever.....	I-35
119862	Clamp Bracket.....	I-58	120685	Set of Parts to Provide Tearing Edge with Cover Glass.....	I-68
119881	Function Lever.....	I-35,54	120686	Glass.....	I-68
119882	Function Lever.....	I-35,54	120687	Blade.....	I-68
119883	Bail.....	I-54	120713	Screw (4-40 x 1-1/16 Fil.).....	I-3,52
119885	Stop Bracket.....	I-54	120714	Hub.....	I-57;IV-4
119886	Screw (4-40 Eccentric Shoulder).....	I-54	120720	Spring Cushion Keytop.....	I-39
119887	Shield.....	I-61	120725	Spring Cushion Keytop.....	I-40
119925	Stop Nut.....	I-34;IV-3	120726	Spring Cushion Keytop.....	I-40
119975	Set of Parts for Paper-Out Device.....	I-68	120733	Spring Cushion Keytop.....	I-39
120012	Type Pallet.....	I-38	120735	Spring Cushion Keytop.....	I-40
120013	Type Pallet.....	I-39	120737	Spring Cushion Keytop.....	I-40
120014 through 120016	Type Pallets.....	I-38	120739	Spring Cushion Keytop.....	I-40
120017 through 120020	Type Pallets.....	I-39	120743	Spring Cushion Keytop.....	I-40
			120744	Spring Cushion Keytop.....	I-40
			120745	Spring Cushion Keytop.....	I-39
			120746	Spring Cushion Keytop.....	I-40
			120747	Spring Cushion Keytop.....	I-39
			120750	Spring Cushion Keytop.....	I-39

Part Number	Description	Page	Part Number	Description	Page
120751			120934	Type Pallet.....	I-39
through 120753	Spring Cushion Keytops.....	I-40	120935	Type Pallet.....	I-39
120754	Spring Cushion Keytop.....	I-39	120936		
120756	Spring Cushion Keytop.....	I-39	through 120940	Type Pallets.....	I-38
120761	Spring Cushion Keytop.....	I-39	120941	Type Pallet.....	I-39
120765	Spring Cushion Keytop.....	I-40	120942	Type Pallet.....	I-39
120770	Spring Cushion Keytop.....	I-39	120943	Type Pallet.....	I-38
120771	Spring Cushion Keytop.....	I-40	120944	Type Pallet.....	I-39
120772	Spring Cushion Keytop.....	I-40	120945	Type Pallet.....	I-39
120775	Spring Cushion Keytop.....	I-40	120946		
120778	Spring Cushion Keytop.....	I-39	through 120948	Type Pallets.....	I-38
120780	Spring Cushion Keytop.....	I-39	120949	Type Pallet.....	I-39
120781	Spring Cushion Keytop.....	I-40	121051	Bracket.....	I-22
120782	Spring Cushion Keytop.....	I-40	121052	Spring.....	I-22
120786			121057	Backstop Bracket.....	I-22
through 120788	Spring Cushion Keytops.....	I-39	121058	Range Finder and Line Test	
120790	Spring Cushion Keytop.....	I-39		Key Door.....	I-47,48
120791	Spring Cushion Keytop.....	I-39	121095	Paper Guide Plate.....	I-67
120792	Spring Cushion Keytop.....	I-40	121096	Paper Guide Plate Assembly....	I-67
120793	Spring Cushion Keytop.....	I-40	121098	Paper Guide.....	I-61
120794	Spring Cushion Keytop.....	I-39	121102	Plate.....	I-52
120805	Spring Cushion Keytop.....	I-39	121103	Plate.....	I-52
120810	Spring Cushion Keytop.....	I-39	121104	Stud.....	I-52
120811	Spring Cushion Keytop.....	I-39	121107	Gear.....	I-52
120814	Spring Cushion Keytop.....	I-40	121108	Washer-Sirvene.....	I-52
120815	Spring Cushion Keytop.....	I-39	121112	Cam Assembly.....	I-52;IV-3
120816	Spring Cushion Keytop.....	I-39	121113	Handwheel.....	I-52
120834	Celluloid Keytop.....	I-40	121114	Washer.....	I-52
120835	Celluloid Keytop.....	I-40	121116	Gear Assembly.....	I-52
120870	Wick.....	I-11	121117	Stud.....	I-52
120893	Celluloid Keytop.....	I-40	121118	Bushing.....	I-52
120900	Type Pallet.....	I-38	121119	Hub.....	I-52
120901	Type Pallet.....	I-39	121120	Collar.....	I-52
120902	Type Pallet.....	I-38	121122	Bushing.....	I-52
120903	Type Pallet.....	I-39	121123	Stud.....	I-52
120904	Type Pallet.....	I-38	121124	Collar.....	I-52
120905	Type Pallet.....	I-38	121125	Spring Washer.....	I-52
120906	Type Pallet.....	I-39	121127	Gear (33T).....	IV-4
120907	Type Pallet.....	I-39	121128	Gear (51T).....	IV-4
120910			121130	Set of Parts to Provide Platen	
through 120914	Type Pallets.....	I-39		Indexing Feature on Sprocket	
120915	Type Pallet.....	I-38		Feed Printer.....	I-52;IV-4
120916	Type Pallet.....	I-38	121173	Gear (20T).....	IV-4
120917			121174	Gear (55T).....	IV-4
through 120919	Type Pallets.....	I-39	121175	Gear (20T).....	IV-4
120920			121176	Gear (44T).....	IV-4
through 120922	Type Pallets.....	I-38	121177	Gear (24T).....	IV-4
120924			121178	Gear (44T).....	IV-4
through 120927	Type Pallets.....	I-39	121179	Gear (28T).....	IV-4
120928	Type Pallet.....	I-38	121180	Gear (44T).....	IV-4
120929			121181	Gear (32T).....	IV-4
through 120931	Type Pallets.....	I-39	121182	Gear (44T).....	IV-4
			121183	Gear (36T).....	IV-4
			121184	Gear (40T).....	IV-4
			121186	Gear (33T).....	IV-4
			121187	Gear (39T).....	IV-4
			121188	Gear (42T).....	IV-4

Part Number	Description	Page	Part Number	Description	Page
121189	Gear (33T).....	IV-4	122368	Contact Spring.....	I-72
121190	Gear (45T).....	IV-4	122369	Guard.....	I-72
121191	Gear (48T).....	IV-4	122370	Cable.....	I-72
121196	Gear (22T).....	IV-4	122371	Lever.....	I-72
121213	Cable.....	I-60	122372	Bracket.....	I-72
121214	Set of Gears.....	IV-4	122373	Screw (6-40 Shoulder).....	I-72
121215	Set of Gears.....	IV-4	122375	Bracket.....	I-72
121216	Set of Gears.....	IV-4	122376	Cable.....	I-72
121218	Set of Gears.....	IV-4	122377	Switch.....	I-72
121219	Set of Gears.....	IV-4	122380	Bracket.....	I-58
121220	Set of Gears.....	IV-4	122382	Type Bar Guide.....	I-69
121221	Set of Gears.....	IV-4	122531	Paper Finger - Right.....	I-60
121223	Set of Gears.....	IV-4	122532	Paper Finger - Left.....	I-60
121224	Set of Gears.....	IV-4	122533	Spring.....	I-60
121225	Set of Gears.....	IV-4	122534	Spring.....	I-60
121226	Set of Gears.....	IV-4	122535	Shaft.....	I-60
121227	Set of Gears.....	IV-4	122536	Hub.....	I-60
121232	Set of Gears.....	IV-4	122541	Function Lever.....	I-35
121321	Cable.....	I-60	122542	Function Lever.....	I-35
121323	Insulating Sleeve.....	I-60	122741	Washer - Felt.....	I-16
121927	Strap.....	I-44	122744	Washer - Felt.....	I-16
122037	Magnet Bracket.....	I-71	122745	Washer - Felt.....	I-16
122039	Bracket.....	I-70	122752	Wick.....	I-16
122057	Switch.....	I-52	122754	Cam Sleeve.....	I-31
122059	Spring.....	I-16	122838	Spacer.....	I-16;IV-1
122065	Spring Cushion Keytop.....	I-40	122874	Function Lever.....	I-35,71
122089	Spring Cushion Keytop.....	I-40	122875	Type Pallet.....	I-39
122103	Spring.....	I-52	122876	Type Pallet.....	I-38
122104	Contact Lever.....	I-52	122877		
122208	Washer.....	I-57	through	Type Pallets.....	I-39
122293	Governed Motor.....	I-43	122881		
122297	Governed Motor.....	I-43	122882		
122301	Governed Motor.....	I-43	through	Type Pallets.....	I-38
122310	Type Pallet.....	I-38	122885		
122311	Type Pallet.....	I-38	122886	Type Pallet.....	I-39
122340			122887	Type Pallet.....	I-39
through	Type Pallets.....	I-39	122888	Type Pallet.....	I-38
122343			122889	Type Pallet.....	I-38
122346			122890	Type Pallet.....	I-39
through	Type Pallets.....	I-38	122891	Type Pallet.....	I-39
122348			122893	Type Pallet.....	I-39
122349			122895		
through	Type Pallets.....	I-39	through	Type Pallets.....	I-39
122352			122902		
122353	Type Pallet.....	I-38	122903	Type Pallet.....	I-38
122354	Type Pallet.....	I-39	122904	Type Pallet.....	I-39
122355	Type Pallet.....	I-38	122905	Type Pallet.....	I-39
122356	Type Pallet.....	I-39	122906	Type Pallet.....	I-38
122357	Type Pallet.....	I-39	122907	Type Pallet.....	I-39
122358	Type Pallet.....	I-38	122908	Type Pallet.....	I-39
122359	Type Pallet.....	I-39	122909	Type Pallet.....	I-38
122362	Set of Parts for Switch Cut-In and Automatic Cut-Out of Horizontal Tabulation Feature.....	I-72	122910	Type Pallet.....	I-39
122363	Plate.....	I-72	122911	Type Pallet.....	I-38
122364	Bracket.....	I-72	122912		
122365	Plate.....	I-72	through	Type Pallets.....	I-39
122366	Contact Bracket.....	I-72	122914		
122367	Guard.....	I-72	122915	Type Pallet.....	I-38

Part Number	Description	Page	Part Number	Description	Page
122916 through 122924	Type Pallets.....	I-39	123763	Apparatus Mounting.....	I-59
122974	Capstan Nut.....	I-16;IV-1	123764	Cam Follower.....	I-58
123005	Spring Cushion Keytop.....	I-40	123765	Cable.....	I-59
123006	Spring Cushion Keytop.....	I-40	123786	Stud.....	I-72
123012	Spring Cushion Keytop.....	I-39	123823	Washer.....	I-31
123013	Spring Cushion Keytop.....	I-40	123864	Insulator.....	I-31
123014	Spring Cushion Keytop.....	I-40	123865	Guard.....	I-31
123015	Spring Cushion Keytop.....	I-39	123933	Bracket.....	I-69
123017	Spring Cushion Keytop.....	I-40	123946	Plate.....	I-71
123018	Spring Cushion Keytop.....	I-39	123947	Plate.....	I-75
123021	Spring Cushion Keytop.....	I-40	123948	Pawl.....	I-75
123023	Spring Cushion Keytop.....	I-39	123949	Latch.....	I-75
123024	Spring Cushion Keytop.....	I-40	123953	Blocking Bail.....	I-71,76
123025	Spring Cushion Keytop.....	I-40	124033	Tabulator Bar.....	I-51;IV-3
123026	Spring Cushion Keytop.....	I-39	124034	Tabulator Stop.....	I-51;IV-3
123027	Spring Cushion Keytop.....	I-40	124035	Reset Stop.....	I-51;IV-3
123028	Spring Cushion Keytop.....	I-39	124420	Function Lever.....	I-35
123029	Spring Cushion Keytop.....	I-40	124421	Function Lever.....	I-35
123030	Spring Cushion Keytop.....	I-40	124477	Magnet Bracket.....	I-70
123033	Spring Cushion Keytop.....	I-39	124478	Resistor Bracket Assembly.....	I-70
123035	Spring Cushion Keytop.....	I-40	124480	Bracket.....	I-31
123036	Spring Cushion Keytop.....	I-39	124539	Release Lever.....	I-55
123037	Spring Cushion Keytop.....	I-40	124540	Spacer.....	I-55
123038	Spring Cushion Keytop.....	I-39	124541	Shaft.....	I-55
123039	Spring Cushion Keytop.....	I-40	124591	Cable.....	II-4
123040	Spring Cushion Keytop.....	I-39	124608	Instruction Card Holder.....	I-55
123041	Spring Cushion Keytop.....	I-39	124609	Window - Plastic.....	I-55
123042	Spring Cushion Keytop.....	I-40	124623	Pawl (with Hub).....	I-51
123043	Spring Cushion Keytop.....	I-39	124624	Pawl Extension.....	I-51
123044	Spring Cushion Keytop.....	I-40	124625	Space Pawl Assembly.....	I-51
123048	Spring Cushion Keytop.....	I-39	124681	Screw (6-40 Set).....	I-21
123049	Spring Cushion Keytop.....	I-40	124687	Type Pallet.....	I-39
123050	Spring Cushion Keytop.....	I-39	124688	Type Pallet.....	I-39
123051	Spring Cushion Keytop.....	I-40	124689	Type Pallet.....	I-38
123054	Spring Cushion Keytop.....	I-40	124690	Type Pallet.....	I-39
123056	Spring Cushion Keytop.....	I-40	124741	Lock Washer.....	I-27
123057	Spring Cushion Keytop.....	I-39	124842	Pressure Roller.....	I-55
123058	Spring Cushion Keytop.....	I-40	124876	Screw (2-56 x 1/4 Rd.Hd.).....	I-61
123059	Spring Cushion Keytop.....	I-39	124877	Screw (2-56 x 1/2 Rd.Hd.).....	I-61
123060	Spring Cushion Keytop.....	I-39	124915	Motor Control Relay.....	I-6
123061	Spring Cushion Keytop.....	I-58	124971	Switch Operating Bracket.....	I-60
123101	Celluloid Keytop.....	I-40	124973	Washer.....	I-29,32,60
123525	Modification Kit for Manually Controlled Two-Color Printing.....	I-70	124994	Post.....	I-23
123540	Cable Assembly.....	I-31	124999	Switch.....	I-60
123743	Counter Assembly.....	I-58	125002	Screw (8-32 x 3/8 Flat Hd.).....	I-1
123744	Accessory Box.....	I-58,59	125006	Screw (10-32 x 5/8 Flat Hd.).....	I-7
123745	Set of Parts for Line Feed Counting.....	I-58,59	125010	Washer - Fiber.....	I-4
123756	Apparatus Box.....	I-59	125011	Washer....I-3,22,23,24,25,27,31,4748,54,56,58,64,69,II-1;III-3	
123757	Bracket.....	I-59	125012	Lamp Socket.....	I-58
123758	Capacitor - 1 MF.....	I-59	125015	Washer....I-1,17,25,29,42,67,68,72	
123759	Contact Assembly.....	I-58	125112	Screw (2-56 x 1/8 Fil.).....	I-6
123760	Selector.....	I-59	125119	Screw (4-40 Shoulder)....I-3,34,52 53,73;III-3	
123761	Contact Bank.....	I-59	125120	Screw (6-40 Shoulder)...I-18,23,63	
123762	Apparatus Mounting.....	I-59	125122	Screw (2-56 x 3/4 Fil.).....	I-6,74
			125126	Screw (2-56 x 9/32 Fil.).....	I-63
			125138	Screw (2-56 x 3/8 Fil.).....	I-58
			125139	Screw (4-40 x 1/8 Fil.)..I-46,62,66	

Part Number	Description	Page	Part Number	Description	Page
125143	Screw (6-32 x 3/8 Flat Hd.)	I-49;III-2	129480	Set of Parts to Open and Close	
125155	Screw (6-40 x 1/2 Fil.)	I-46,71		External Circuits	I-74
125159	Screw (6-40 Pilot)	I-22	129481	Function Lever	I-35,74
125168	Screw (6-40 x 1/4 Fil.)	I-4	129482	Blocking Bail	I-74,76
125170	Screw (8-32 x 5/16 Fil.)	I-59	129483	Blocking Bail	I-74,76
125171	Screw (10-32 x 1/2 Flat Hd.)	I-1	129485	Cable	I-74
125176	Screw (3-56 Pilot)	I-7	129516	Insulator	I-3,52
125180	Screw (4-40 Shoulder)	I-25,54	129557	Blocking Bail	I-76
125218	Nut (1/4-32 Hex)	I-17,18,22 23,30,33	129821		
125220	Nut (8-40 Hex)	I-23	through	Type Pallets	I-39
125229	Nut (6-32 Hex)	I-10,58,66	129827		
125235	Nut (4-36 Hex)	I-47,48;III-2;IV-3	129966	Hub	I-57;IV-4
125236	Spring	I-63,64	135000	Platen - Hard Rubber	I-28
125245	Spring	I-73	135001	Platen - Hard Rubber	I-28
125253	Spring	I-53,70,73	135265	Gear (42T)	IV-4
125268	Spring	I-65;II-1	135266	Set of Gears	IV-4
125282	Pin	I-52	135270	Lever	I-69
125297	Dowel Pin	I-14,15,17,20	135271	Eccentric Bushing	I-69
125306	Plunger Stop	I-6	135272	Blocking Plate	I-69
125330	Screw (8-40 x 2-17/32 Fil.)	I-70	135767	Wearing Plate	I-74
125369	Resistor	III-1	135771	Screw (6-40 Special)	I-24;IV-2
125379	Spring Post	I-14,17	136394	Cam	IV-3,4
125390	Washer	I-6,50	150383	Spacer	I-75
125393	Dowel Pin	I-14,15	151152	Screw (4-40 x 3/16 Hex)	I-69
125395	Dowel Pin	I-17,18	151223	Screw (4-40 Special)	I-60
125418	Spring Post	I-24	151637	Screw (4-40 x 1/4 Fil.)	I-31,58
125457	Plug (2 Prong)	I-9,65	151657	Screw (6-40 x 1/4 Fil.)	I-70
125463	Packing	I-10			
125789	Washer	I-63,64			
125802	Washer	I-3			
125949	Screw (0-80 x 1/8 Fil.)	I-63			
126234	Pin	I-21			
126746	Set of Keytops - Spring Cushion	I-39,40			
126747	Set of Type Pallets - Long Gothic Style	I-36			
126750	Set of Type Pallets - Long Gothic Style	I-36			
126751	Screw (6-40 Eccentric Shoulder)	I-60			
126752	Shoulder Bushing	I-60			
126753	Paper-Out Bail	I-60			
126754	Switch Mounting Plate	I-60			
126755	Link	I-60			
126756	Reset Lever	I-60			
126758	Spring	I-60			
126759	Screw (4-40 Eccentric Shoulder)	I-60			
126891	Function Lever	I-35,75			
126955	Ribbon Guide	I-25,27			
126979	Function Lever	I-35,73			
126993	Set of Gears	IV-4			
128648	Card Holder	I-55			
128670	Spring	I-21			
128671	Slide Bar	I-27			
128672	Loading Plate	I-27			