

BULLETIN 125
ISSUE 2
AUGUST, 1937

TELETYPE

PRINTING TELEGRAPH SYSTEMS

DESCRIPTION AND ADJUSTMENTS
OF THE
TELETYPE WHEATSTONE PERFORATOR

TELETYPE
CORPORATION
SUBSIDIARY OF
Western Electric Company
CHICAGO, U.S.A.





C O N T E N T S

	<u>Page</u>
<u>Adjustments</u>	5
Bell Crank Stop Screw Adjustment	16
Brake Arm Adjustment	17
Combination Lever Link Adjustment	13
Connecting Links Adjustment	11
Contact Screw Adjustment	8
Detent Adjusting Block Adjustment	13
Feed Lever Advancing Screw Adjustment	14
Feed Lever Retracting Screw Adjustment	14
Feed Lever Stop Screw Adjustment	14
Feed Pawl Stop Screw Adjustment	13
Feed Wheel Stud Adjustment	9
Floating Lever Backstop Adjustment	11
Magnet Lower Core Adjustment	11
Punch Head Adjusting Screw Adjustment	14
Punch Head Slides Adjustment	7
Punch Head Spring Tension Adjustment	16
Punch Head Stop Screws Adjustment	7
Shift Bracket Front Adjusting Screws Adjustment	9
Shift Bracket Rear Adjusting Screws Adjustment	8
Tape Guide Adjustment	9
Tape Reel Stud Adjustment	17
<u>Description</u>	
General	1
Punch Selecting Mechanism	1
Punching Mechanism	2
Signaling Code	1
Tape Feed Mechanism	4
<u>Lubrication Specification</u>	18
Locations on the Bottom Side of the Perforator	18
Locations on the Top Side of the Perforator	18

Spring Tensions

Brake Arm Spring Torsion	17
Combination Lever Spring Tension	13
Connecting Bar Spring Tension	5
Contact Spring Pressure	7
Detent Spring Tension	13
Die Slot Cover Spring Tension	12
Feed Pawl Spring Tension	9
Floating Lever Spring Tension	12
Left Unshift Spring Tension	7
Main Lever Spring Tension	16
Pressure Block Arm Spring Tension	10
Punch Head Spring Tension Adjustment	16
Right Unshift Spring Tension	6
Selecting Bar Spring Tension	6
Shock Absorber Spring Torsion	18
Universal Pressure Bar Spring Tension	11

DESCRIPTION OF THE TELETYPE WHEATSTONE PERFORATOR

GENERAL

The Teletype Wheatstone Perforator is a unit of apparatus that is used to perforate tape for automatic telegraph transmission. It is a self-contained, magnet (solenoid type) operated portable unit. It consists essentially of a set of key levers, a punch selecting mechanism, a punching mechanism, and a tape feed mechanism. When any key lever is depressed, corresponding groups of perforations that represent dot and dash character signals of the Continental Code are perforated in the tape. The perforated tape with the dot and dash character signals thus recorded may be fed automatically through a tape transmitting device, operating a recording instrument at a distant station.

The perforator is equipped with a power cord and attachment plug. D.C. power is required for its operation.

NOTE: In all the figures of this bulletin, fixed pivot points are designated by solid black circles.

Signaling Code

Two types of perforators are available: One known as the "Continental" type; and the other as the "Cable" type. These perforators use the so-called "Continental Code."

On the "Continental" type perforators, dots are represented in the tape by two holes, one of which is above the feed hole and the other directly below it. Dashes are also represented by two holes, one above the feed hole and one below, but the lower hole is positioned to the right of the upper hole (See Figure 1).

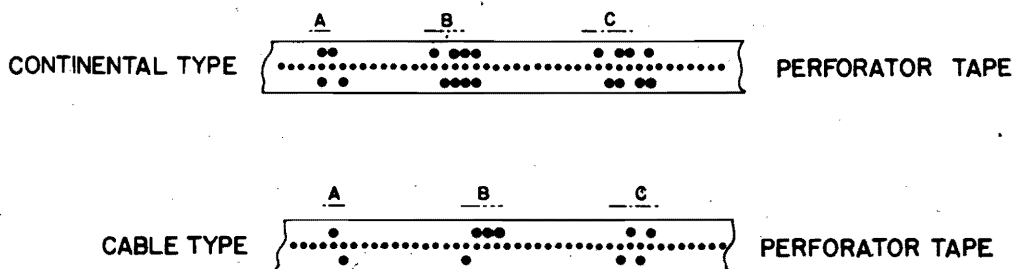

FIGURE 1

"Cable" type perforators use the same code (i.e., Continental Code), but the dots are represented in the tape by only one hole which is located above the feed hole, and dashes are represented in the tape by one hole located below the feed hole.

Punch Selecting Mechanism

Each key lever operates a selecting bar located directly below it, which is held in line by guide projections attached to the sides of the key lever (Figure 2). A spring attached to the rear end of each selecting bar holds both the selecting bar and key lever in their unoperated positions. The lower edge of each selecting bar is notched in accordance with the code combination of the character represented. Located below the selecting bars and at right angles to them are the "T" bars. These bars move up and down in the slots of a guide comb. The vertical portion of each "T" bar has two parallel links pivoted to it (Figure 5), which cause the upper edge of the "T" bar to maintain a horizontal position throughout its travel. A connecting bar makes contact with each "T" bar through a slot in the vertical section

of the "T" bar. A spring attached to the rear section of each connecting bar supports the weight of the "T" bar connected to the front end, and holds the "T" bar in contact with the selecting bars above (Figure 2). A connecting bar spring bracket, set at an angle so as to provide spring positions of different length, causes the connecting bar springs to exert greater tension on the connecting bars having greater length. The rear end of each connecting bar has a connecting link attached thereto which supports a punch selector bar on its upper end. The punch selector bars are located in the punch head directly in line with their respective punches.

When a key lever and its associated selecting bar are depressed, they carry downward, those "T" bars that are not in line with the notches in the selecting bar. Each "T" bar in motion actuates its respective connecting bar which pivots on its fulcrum and raises its connecting link and the attached punch selector bar to a point where the selector bar is positioned behind its respective punch.

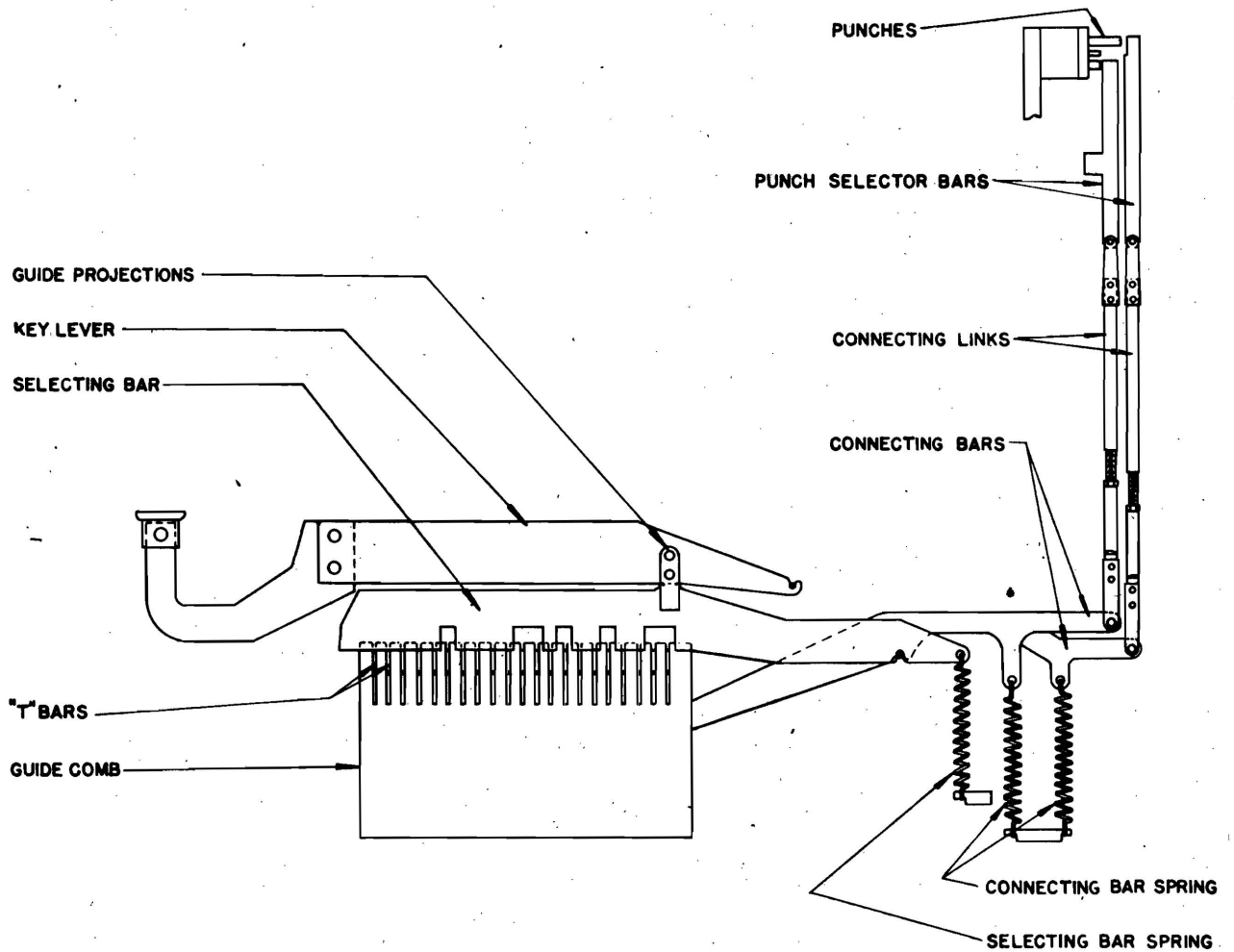

FIGURE 2

Punching Mechanism

The motivating force for the punching operation is supplied by a solenoid magnet and plunger which is operated on a direct current power supply. The solenoid plunger is connected to a main lever, located on top of the perforator, through the medium of a link and bell crank (Figure 3). A valve in the lower core of the magnet regulates the passage of air and thereby cushions the downward stroke of the solenoid plunger. A sliding punch head is located directly in front of the main lever and carries a punch retracting comb on its front face. The teeth of the retracting comb occupy the spaces between the punches of the die block which is mounted directly

in front of the punch head. The three rows of punches are arranged to perforate the tape in consecutive order, beginning with the center row which perforates about .005" in advance of the lower row. The upper row follows the lower by a like margin. This arrangement provides a more uniform distribution of the operating loads. A spring attached to the main lever at its left end holds the main lever and the solenoid plunger in the unoperated position when idle. A spring attached to a post on the punch head holds it in the rearmost position when unoperated.

The depression of any key lever causes the associated selecting bar to depress a "power" "T" bar (foremost) in addition to the "code" "T" bars. The "power" "T" bar actuates a contact bar that closes the power contacts which energize the solenoid magnet. The downward stroke of the solenoid plunger rotates the main lever forward where a punch head adjusting screw, projecting from the central portion of the main lever, comes in contact with the punch head and slides the punch head forward against the tension of its spring. The forward motion of the punch head carries the selected punch selector bars against the punches and pushes the punches through the tape. When the magnet is deenergized, the main lever returns to its normal position and lifts the solenoid plunger through the medium of the main lever spring. The punches are withdrawn from the tape by means of the retracting comb attached to the punch head as the punch head spring returns the punch head to its unoperated position.

Figure 4 shows the methods of connecting the magnet coils at the terminals, depending on the type of magnet used and the voltage of the power supply.

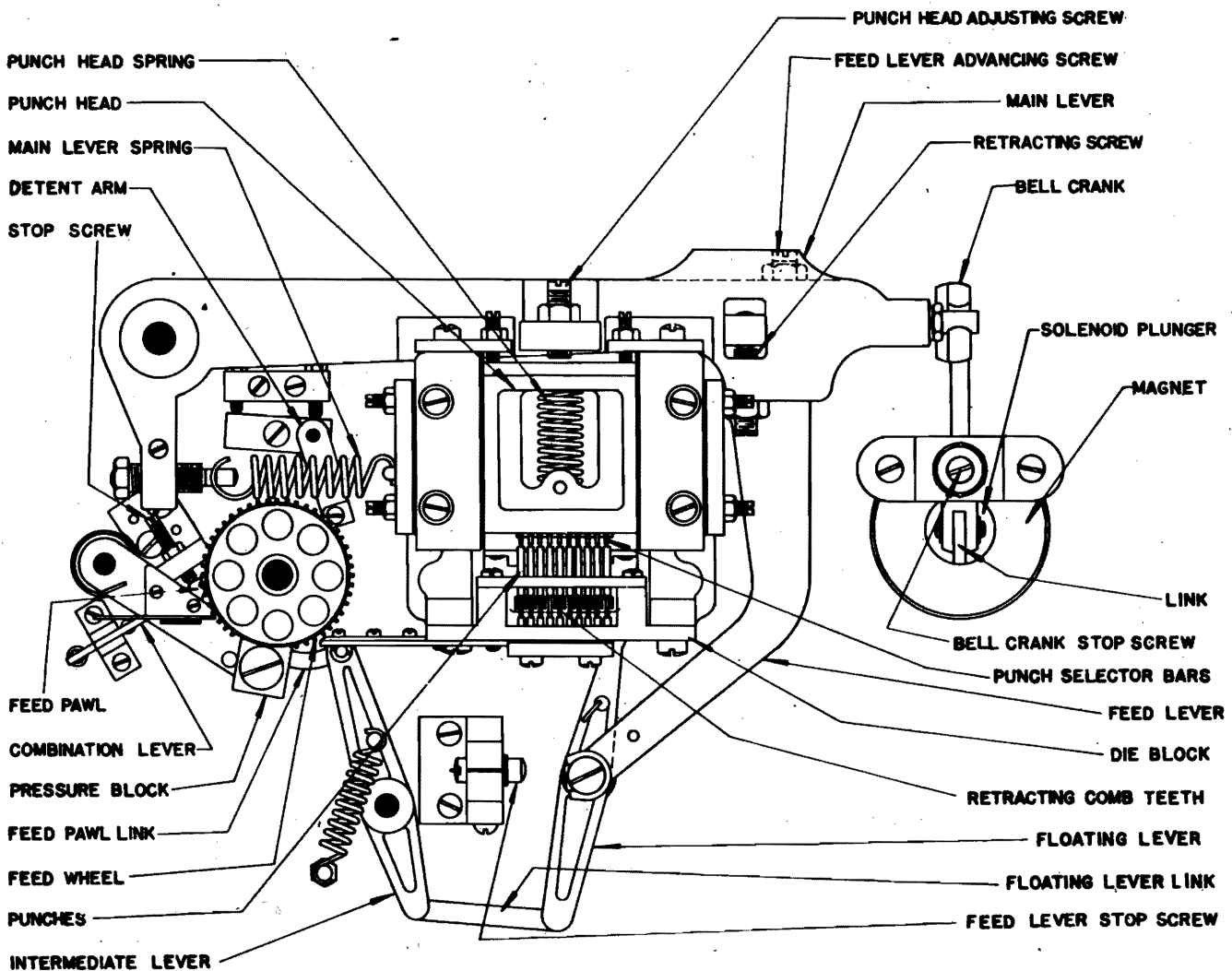
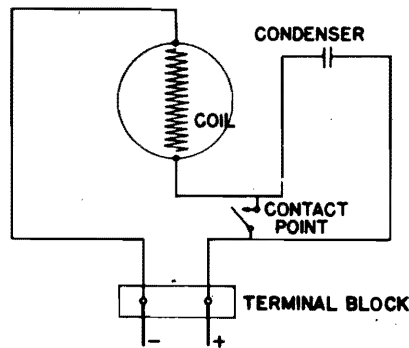

FIGURE 3

Tape Feed Mechanism

A feed lever mounted on a pivot screw located below the main lever carries on its forward end a floating lever (Figure 3). A floating lever link attached to the front end of the floating lever connects the floating lever to an intermediate lever. The intermediate lever is mounted on a pivot screw near its mid-section. Attached to the rear end of the intermediate lever is a feed pawl link which connects with a feed pawl. A feed pawl spring holds the feed pawl in contact with the ratchet teeth of a combined feed wheel and ratchet located to the left of the die block.



CONNECTED FOR SINGLE WOUND COIL

DIAGRAM 1

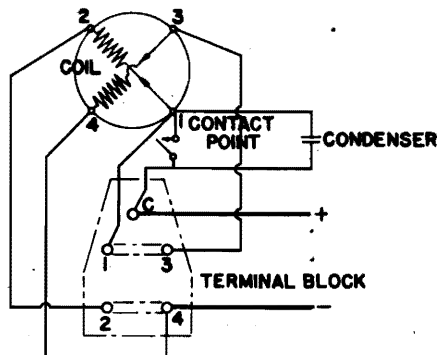

CONNECTED FOR 110 VOLTS
DOUBLE WOUND COIL

DIAGRAM 2

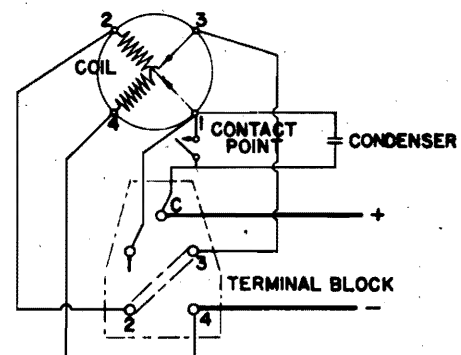

CONNECTED FOR 220 VOLTS
DOUBLE WOUND COIL

DIAGRAM 3

FIGURE 4

A detent arm and roller placed to the rear of the feed wheel rides on the ratchet teeth. The feed pawl is held in its advanced position against a stop screw by the spring which hooks onto the intermediate lever.

The combination lever used to join perforated characters, by eliminating the space between them, is mounted on a bracket to the left of the feed pawl.

On "Continental" type perforators, the front punch selector bars, in addition to selecting the required punches, also act as stops for the floating lever when the punch selector bars are in the selected position. On "Cable" type perforators the punch selector bars, both front and rear, have side projections which engage horizontally positioned floating lever stops when the punch selector bars are being operated. These floating lever stops are carried on the punch head and are held normally depressed by a universal pressure bar which rests on their rear portion. Just above and to the rear of the floating lever stop, on both types of machines, a semi-circular floating lever lock is mounted.

As the main lever rotates forward in operation, a feed lever retracting screw projecting from the front side of the main lever withdraws from the feed lever, allowing the floating lever spring to swing the free end of the feed lever toward the left carrying the floating lever with it. The rear end of the floating lever moves to the left until it strikes a floating lever stop that has been previously raised by a punch selector bar. The continued forward motion of the main lever carries the punch head with the attached floating lever lock forward until a notch in the floating lever lock engages the rear end of the floating lever, thus relieving the stop of further pressure from the floating lever and acting as a fulcrum point for the front end movement of the lever. A feed lever advancing screw projecting through the rear side of the main lever extends the travel of the feed lever. The travel of the forward end of the floating lever is inversely proportional to the travel of the rear end, and this travel is transmitted to the feed pawl, causing it to withdraw from its advanced position against the stop screw. The feed pawl engages the feed wheel ratchet at a point that will feed the tape a distance equivalent to the length of the perforated character plus one space. As the main lever swings backward, the floating lever lock withdraws. The feed lever retracting screw, comes in contact with the feed lever and returns it and the floating lever to the unoperated position. The return motion of the floating lever is transmitted to the feed pawl and causes it to rotate the ratchet and feed wheel. As the feed wheel rotates, it draws the tape through a guide slot in the die and positions it for the next perforation.

"Cable" type perforators are equipped with die blocks having either seven or nine feed hole punches and corresponding code punches. The floating lever stop selected by the "blank" key lever on this type of perforator, occupies a guide slot which provides spacing of five perforations in the tape when a die block having seven feed hole punches is used, and in a second guide slot which provides spacing of seven perforations, when a die block having nine feed hole punches is used. "Cable" type perforators insert three spaces between words when the space bar is operated. "Continental" type perforators may use either two or three spaces between words. On this latter type, a special punch selector bar, having a stop projection permanently raised, is used in No. 1 position when three spaces between words are required.

In order to make available an unusual number of code combinations of dots and dashes, some "Continental" type perforators are equipped with "shift" key levers, which, when operated, shift all selecting bars forward, allowing them to depress a combination of "T" bars different from the combination which would be depressed if the selecting bars were operated in the normal unshifted position. This arrangement makes possible two code combinations for each key lever.

ADJUSTMENTS OF THE TELETYPE WHEATSTONE PERFORATOR

The following adjustments are arranged in a sequence that would be followed if a complete readjustment of the perforator were undertaken. This fact should be kept in mind when a single adjustment is to be made.

The spring tension values specified in this bulletin were derived from measurements made with Teletype spring scales. These spring scales are calibrated for use in a vertical "pull" position. When used in any other position, the reading is an indicated value. Therefore, in order to obtain the proper spring value readings, the spring scales which are included in the Teletype catalogue tool list should be used.

Connecting Bar Spring Tension (Figure 5)

With the perforator resting on its back, hook an 8 oz. scale over the lower link of any "T" bar at the point where the link is pivoted to the "T" bar, and pull at right angles to the link. It should require 1 to 2 ozs. to start the connecting bar moving.

NOTE: After making a single adjustment, check related adjustments.

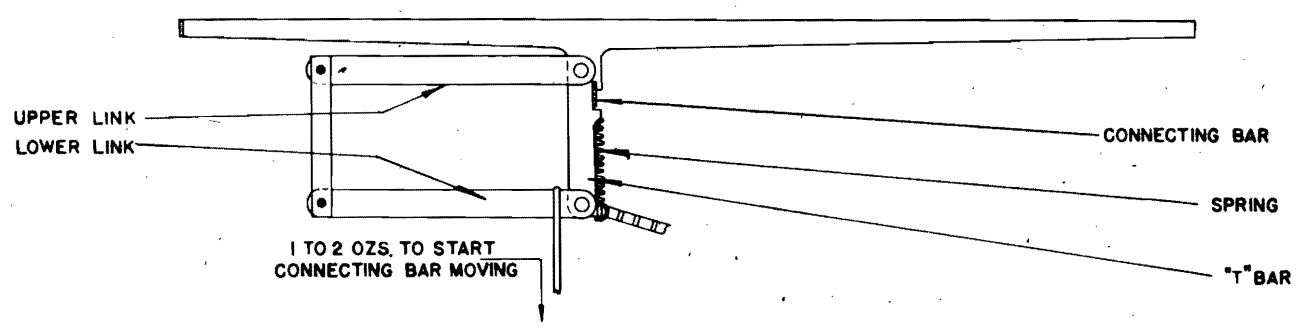

FIGURE 5

Selecting Bar Spring Tension (Figure 6)

NOTE: (a) Applies only to those perforators not equipped with selecting bar shift mechanism.

(b) Applies to perforators equipped with selecting bar shift mechanism.

(a) Place the perforator on its left side. Unhook the "E" selecting bar spring at the spring bracket and hook a 12 lb. scale in the spring eye. It should require 3 to 3-1/2 lbs. to pull the spring to its position length.

Check the "Blank" and "Space" selecting bar springs in the same manner.

All other selecting bar springs should be measured in the same manner with a 32 oz. scale. A tension of 24 to 30 ozs. being required to pull each spring to its position length.

(b) Place the perforator on its left side. Unhook a selecting bar spring at the spring bracket and hook a 32 oz. scale in the spring eye. It should require 12 to 18 ozs. to pull any spring to its position length.

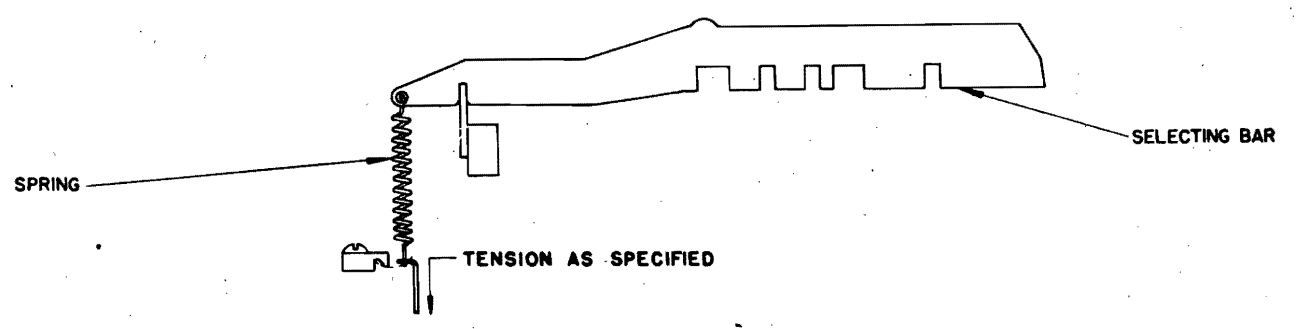

FIGURE 6

Right Unshift Spring Tension (Figure 7)

NOTE: This spring tension applies only to those perforators equipped with selecting bar shift mechanism.

Unhook the right unshift spring at the spring post and hook a 12 lb. scale in the spring eye. It should require 2 to 4 lbs. to pull the spring to its position length.

NOTE: After making a single adjustment, check related adjustments.

Left Unshift Spring Tension (Figure 7)

NOTE: This spring tension applies only to those perforators equipped with selecting bar shift mechanism.

Unhook the left unshift spring at the front end and hook a 12 lb. scale in the spring eye. It should require 1-1/2 to 3-1/2 lbs. to pull the spring to its position length.

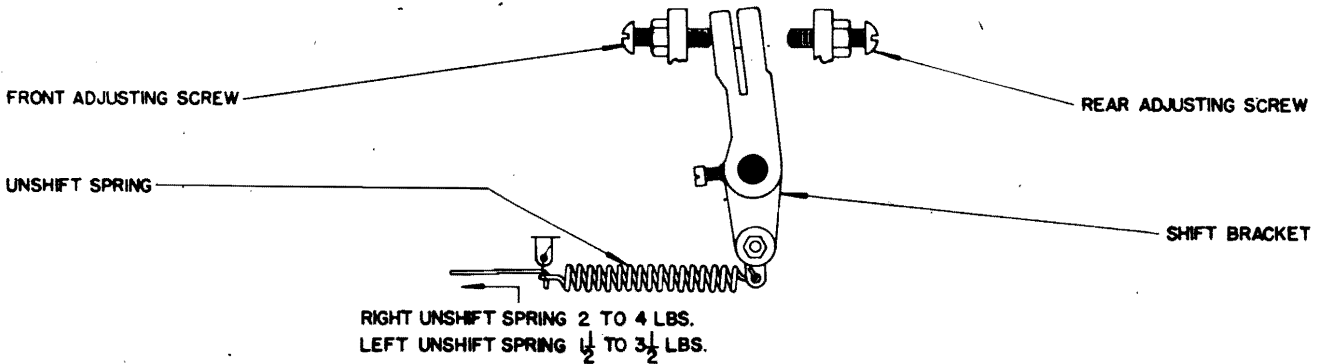

FIGURE 7

Punch Head Slides Adjustment (Figure 8)

The punch head slides should be so positioned that the teeth of the retracting comb clear the sides of the punches by at least .002" and that the punch head will move freely in the slides without side play.

Check the clearance between the teeth of the retracting comb and the punches with the punch head in both the operated and unoperated positions.

To adjust, remove the punch head spring, loosen the punch head slide clamping screws, and back off the slide adjusting screws. Hold the slides against the punch head and position the slides and punch head to meet the foregoing requirements. Clamp the slides in place and set the adjusting screws against the sides of the slides

Replace the punch head spring.

Punch Head Stop Screws Adjustment (Figure 8)

With the punch head resting against its stop screws, each punch should have some end play, not more than .005", between the punch retracting comb teeth and the punch rear guide plate.

Adjust by means of the punch head stop screws, setting the screws so that they will both support the impact plate on the punch head evenly when the punch head is in its rearmost position.

Contact Spring Pressure (Figure 9)

With the perforator resting on its left side, hook an 8 oz. scale over the contact spring at the contact point. A horizontal pull of 1 to 2 oss. should be required to start to depress the contact spring.

To adjust, remove and bend the contact spring.

NOTE: After making a single adjustment, check related adjustments.

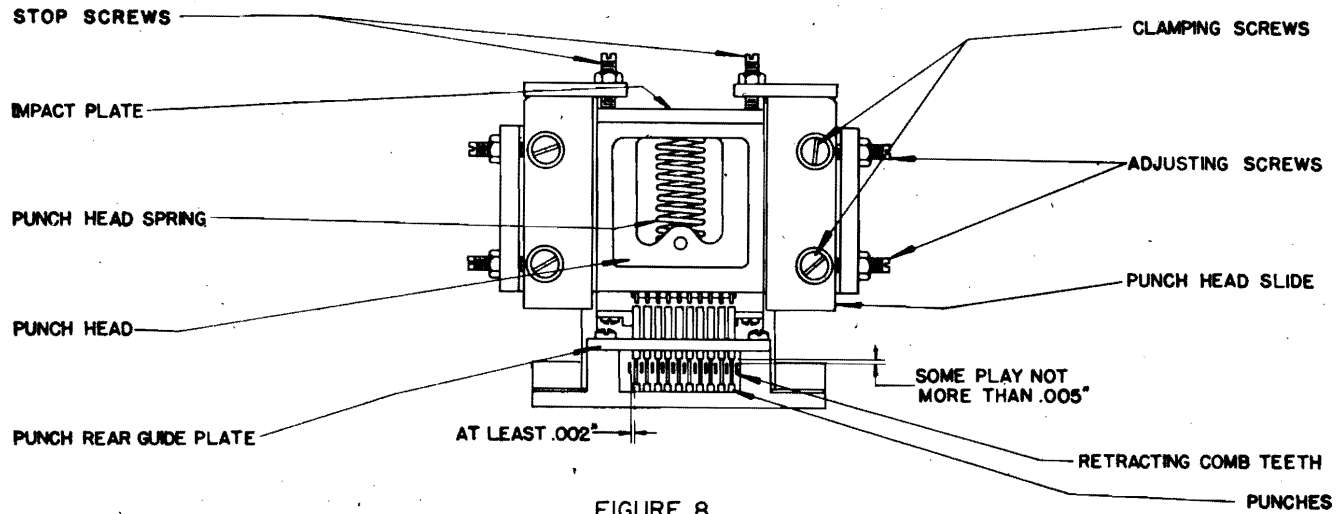

FIGURE 8

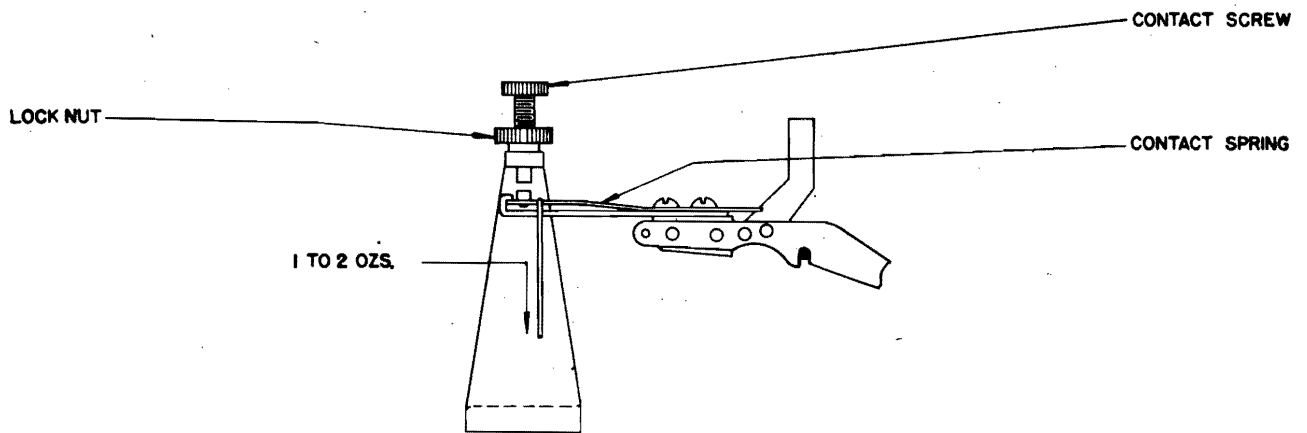

FIGURE 9

Contact Screw Adjustment

When any key lever is depressed the contacts should close with sufficient operating margin.

To adjust, hold depressed any key lever and turn the contact screw just enough to make contact. In this manner, depress any key lever and determine which key lever gives the contact spring the least travel. With this key lever held depressed, turn the contact screw just enough to close the contacts. Then give the contact screw one full turn additional and tighten the lock nut. (See Figure 9 for location of parts.)

NOTE: THE FOLLOWING TWO ADJUSTMENTS APPLY ONLY TO THOSE PERFORATORS EQUIPPED WITH SELECTING BAR SHIFT MECHANISM.

Shift Bracket Rear Adjusting Screws Adjustment

With the shift key levers unoperated, the unshift projections on the selector bars should strike with their center portions on the "T" bars when a character key lever is depressed.

To adjust, set the position of the shift bracket rear adjusting screws both right and left. When both screws are adjusted equally, pieces of perforator tape inserted between the ends of the rear adjusting screws and the bracket on each side will be equally gripped by the screws. (See Figure 7 for location of parts.)

NOTE: After making a single adjustment, check related adjustments.

Shift Bracket Front Adjusting Screws Adjustment

With a shift key lever held depressed, the shift projections on the code bars should strike with their center portions on the "T" bars when a character key lever is depressed.

To adjust, set the position of the shift bracket front adjusting screws, both right and left. When both screws are equally adjusted, pieces of perforator tape inserted between the ends of the front adjusting screws and the bracket on either side should be gripped equally by the screws. (See Figure 7 for location of parts.)

Feed Pawl Spring Tension (Figure 10)

With the intermediate lever held parallel to the sides of the perforator, hook an 8 oz. scale over the end of the feed pawl and pull horizontally at right angles to the pawl. A pull of 3 to 5 ozs. should be required to start the feed pawl moving.

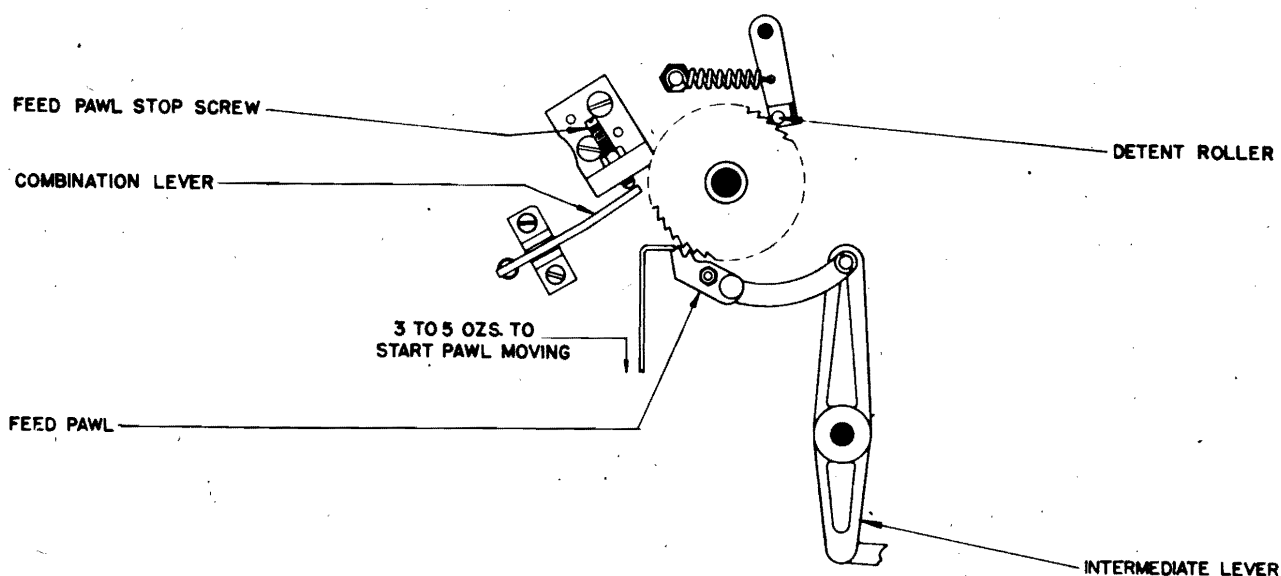

FIGURE 10

Feed Wheel Stud Adjustment (Figure 11)

The feed wheel should rotate freely but without end play.

Adjust by means of the feed wheel stud and lock nut.

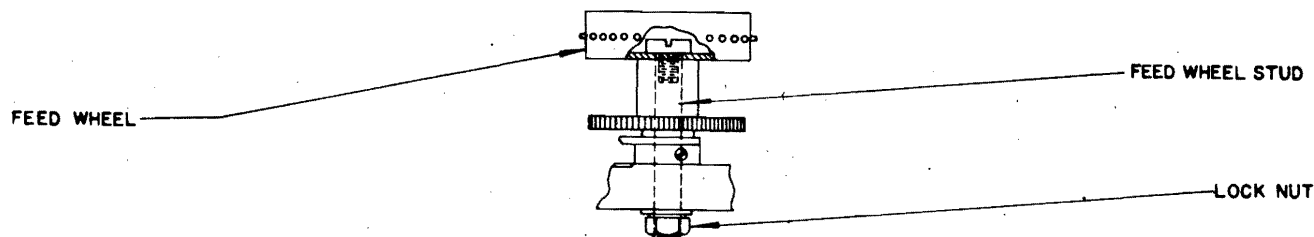

FIGURE 11

Tape Guide Adjustment (Figure 12)

The clearance for the passage of tape between the two sections of the tape guide should be .010" to .015", and the clearance between the end of the tape guide and

NOTE: After making a single adjustment, check related adjustments.

the feed wheel should be .010" to .015".

To adjust, position the tape guides on the pressure block arm by means of their enlarged mounting holes.

Pressure Block Arm Spring Tension (Figure 12)

Hook an 8 oz. scale over the pressure block mounting screw and pull at right angles to the pressure block arm. A pull of 4-1/2 to 5-1/2 ozs. should be required to start the arm moving.

Adjust by loosening the pressure block arm stud lock nut and rotating the stud. Tighten the lock nut.

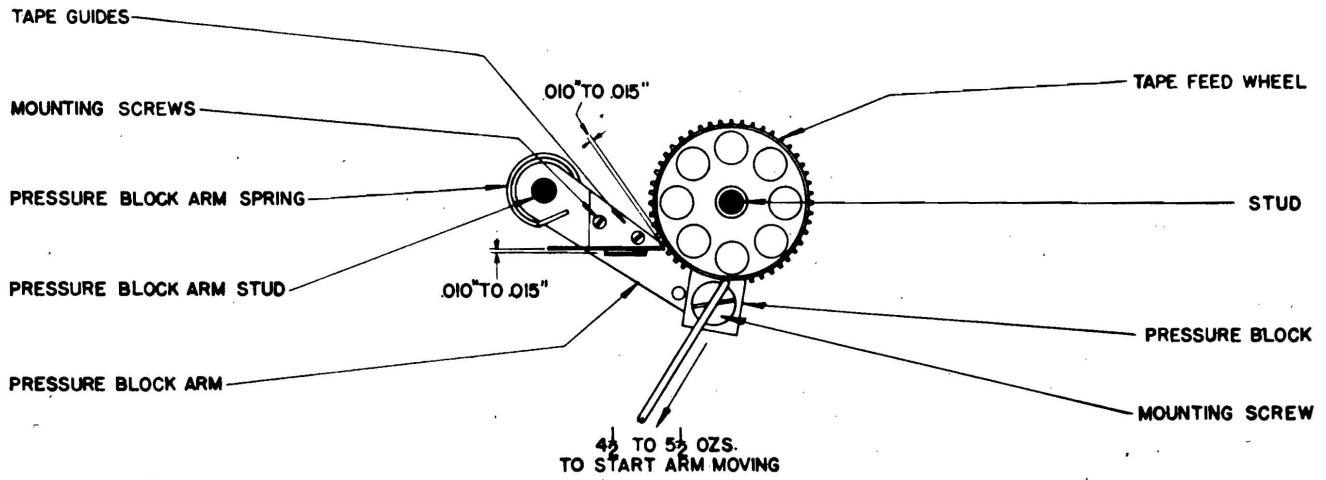

FIGURE 12

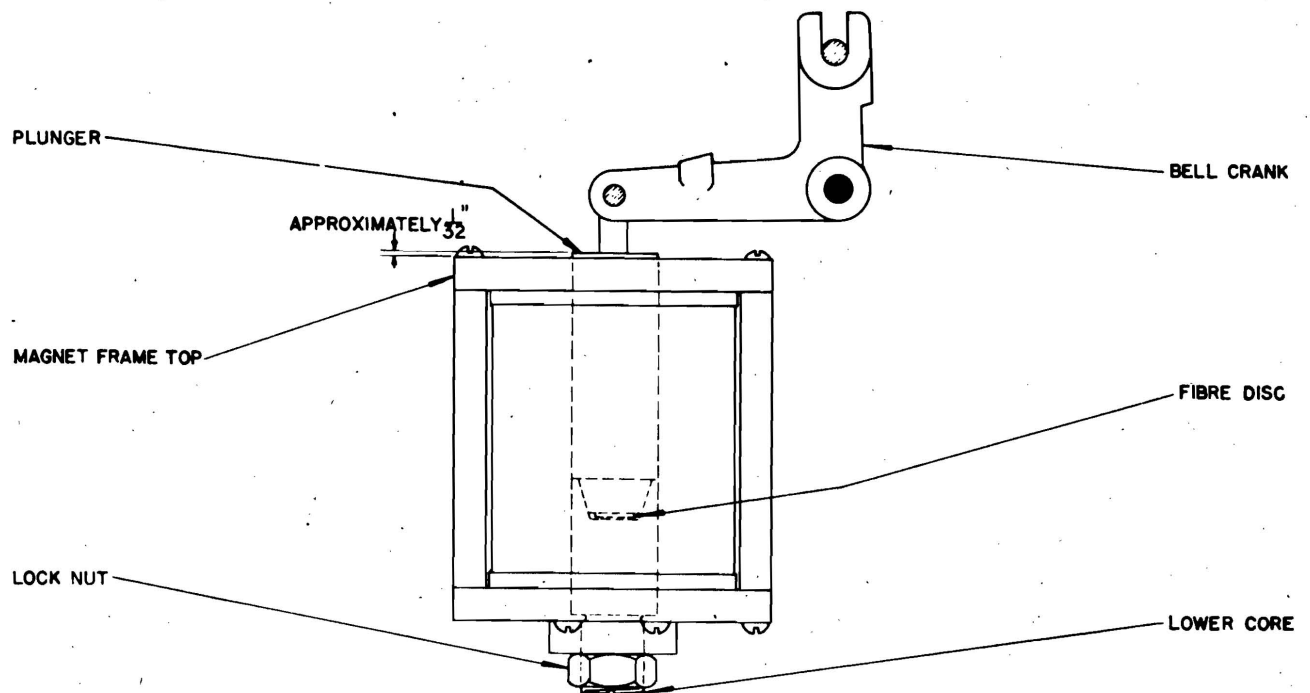

FIGURE 13

NOTE: After making a single adjustment, check related adjustments.

Magnet Lower Core Adjustment (Figure 13)

With the magnet plunger depressed until it strikes the lower core, its upper end should project approximately $1/32$ " above the magnet frame top.

Adjust by loosening the lock nut and rotating the lower core.

NOTE: If necessary back off feed lever advancing screw. (See Figure 3.)

Floating Lever Backstop Adjustment (Figure 14)

The floating lever backstop should clear both the locking rack and the lower front punch selector bar guide by at least $.004$ ".

To adjust, position the backstop by means of its mounting screws.

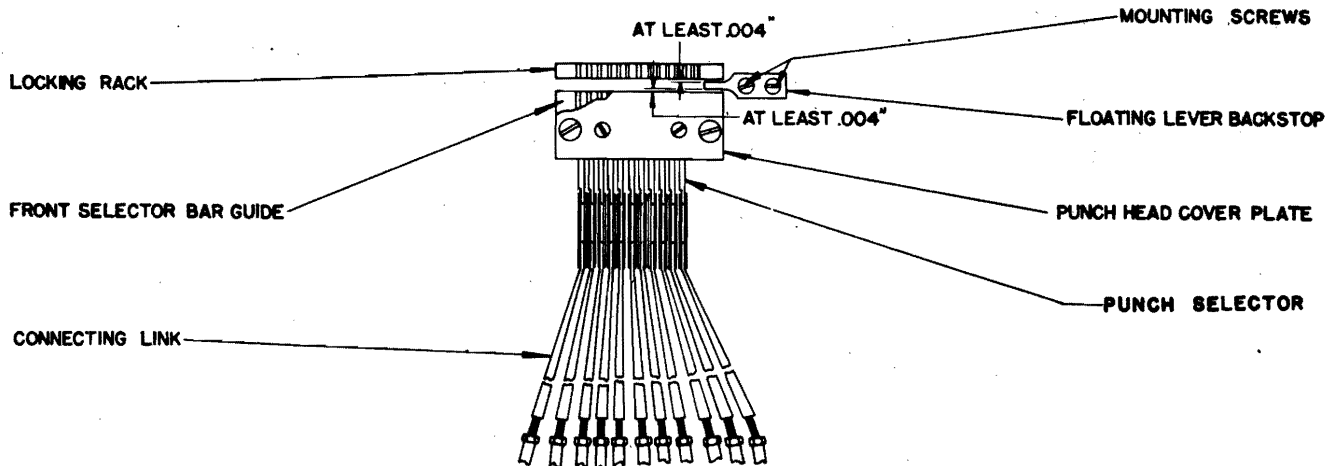

FIGURE 14

Universal Pressure Bar Spring Tension (Figure 15)

NOTE: This spring tension applies only to "Cable" type perforators.

Hook an 8 oz. scale under the universal pressure bar and pull up, vertically. It should require $1-1/2$ to $2-1/2$ ozs. to start the bar moving.

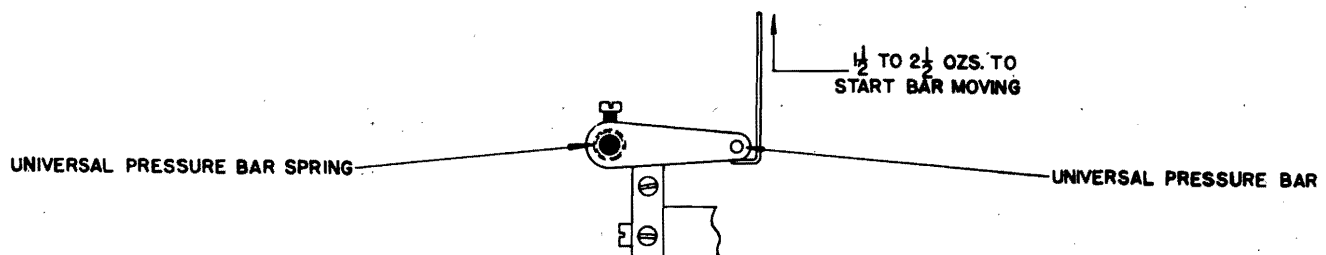

FIGURE 15

Connecting Links Adjustment

The travel of the punch selector bars should be adjusted to meet the following requirements:

NOTE: After making a single adjustment, check related adjustments.

- (a) When any key lever is depressed until the contacts just close, the floating lever stops should rise to approximately one-half the thickness of the floating lever, at the point where it engages the stop, and all punch selector bars should rise to at least one-quarter of the diameter of their respective punches.
- (b) When any key lever is fully depressed, the punch selector bars should rise to at least one-half the diameter of the punches.
- (c) With the key levers unoperated, the floating lever stops should drop flush with the top surface of the punch head cover plate, and all punch selector bars should clear the lower side of the punches by at least .002" when the punch head is moved forward by hand.

To adjust, disconnect the connecting links at one end and regulate their length. (See Figures 14 and 20 for location of parts.)

Floating Lever Spring Tension (Figure 16)

Push down on the magnet plunger until the floating lever just touches the floating lever stationary stop. Then hook an 8 oz. scale in the spring hole on the floating lever and pull at right angles to the lever. It should require 3 to 5 ozs. to start the lever moving.

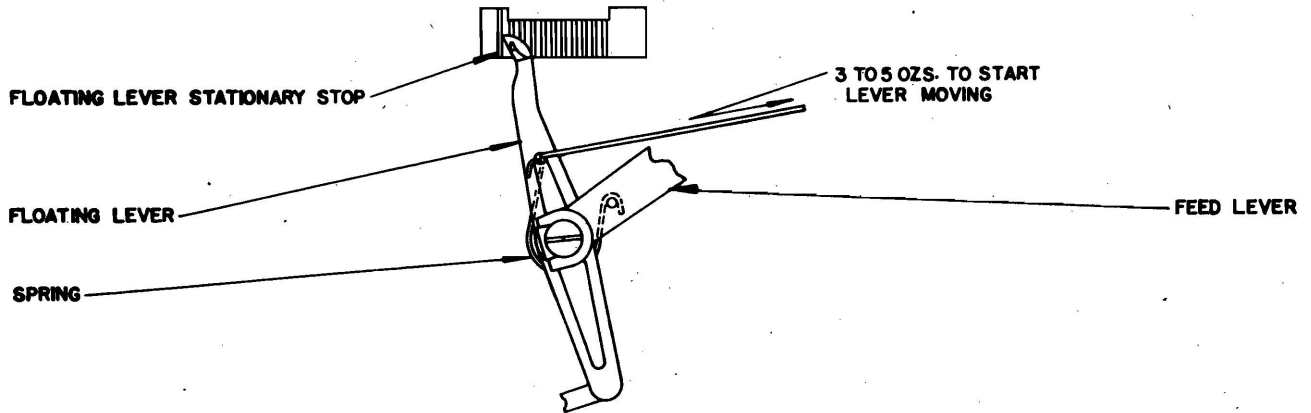

FIGURE 16

Die Slot Cover Spring Tension (Figure 17)

Hook an 8 oz. scale over the center of the lip on the front edge of the die slot cover and pull at right angles to the cover. It should require $\frac{3}{4}$ to $1\frac{3}{4}$ ozs. to start the cover moving.

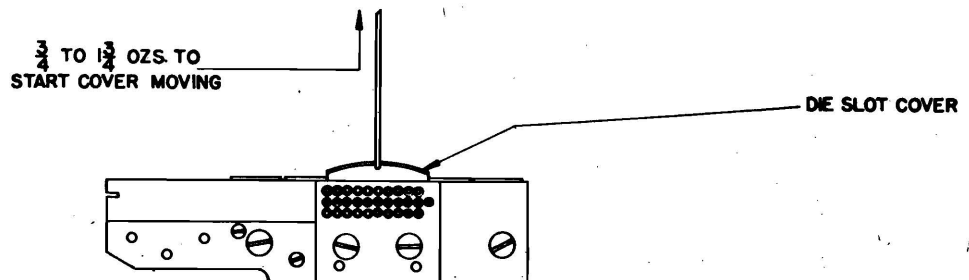

FIGURE 17

NOTE: After making a single adjustment, check related adjustments.

Detent Adjusting Block Adjustment

The feed hole perforations in the tape should meet the standard spacing of ten holes to the inch when checked with the tape gauge (Catalogue No. 2215).

Adjust as follows: Perforate a row of feed holes in the end of a six inch piece of tape and move the tape through the tape channel until the feed holes are over the pins on the feed wheel and under the pressure block. Hold the feed pawl away from the ratchet, allowing the detent roller to set in the notch between two ratchet teeth, and perforate another row of feed holes in the tape. Then check the perforations at each end against the gauge. One feed hole of the first group of perforations should be in the center of the first hole in the gauge, when a hole of the last group of perforations is in the center of the next to the last hole in the gauge. Adjust the position of the detent adjusting block by means of its adjusting screws until the perforations in the tape align with the holes in the gauge. The adjusting block and bracket should be kept as nearly parallel as the adjustment will permit. (See Figure 18 for location of parts.)

Detent Spring Tension (Figure 18)

Unhook the detent spring at the spring post and hook a 32 oz. scale in the spring eye. It should require 14 to 20 ozs. to stretch the spring to its position length.

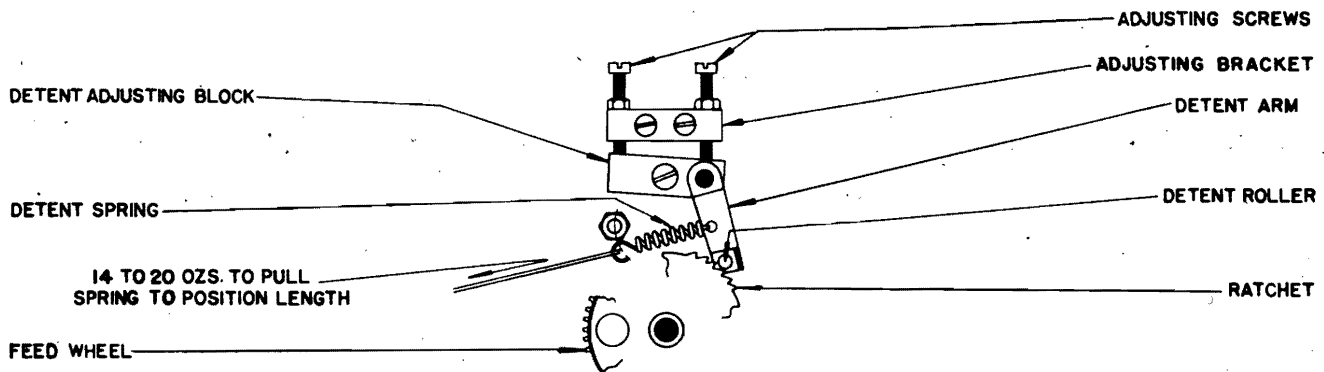

FIGURE 18

Feed Pawl Stop Screw Adjustment

The feed pawl stop screw should stop the feeding travel of the feed pawl at the same time that the detent roller falls into the notch between the ratchet teeth. (See Figure 10 for location of parts.)

To adjust, position the feed pawl stop screw. Check all ratchet teeth for variations.

Combination Lever Link Adjustment

The combination lever should clear the lower surface of the feed pawl when in the unoperated position, and it should rise above the center of the feed pawl stop screw when in the operated position.

Adjust by means of the combination lever link. (See Figures 10 and 19 for location of parts.)

Combination Lever Spring Tension (Figure 19)

With the feed pawl held to the right, hook an 8 oz. scale under the end of the combination lever and pull up vertically. It should require 3 to 5 ozs. to start the combination lever moving.

NOTE: After making a single adjustment, check related adjustments.

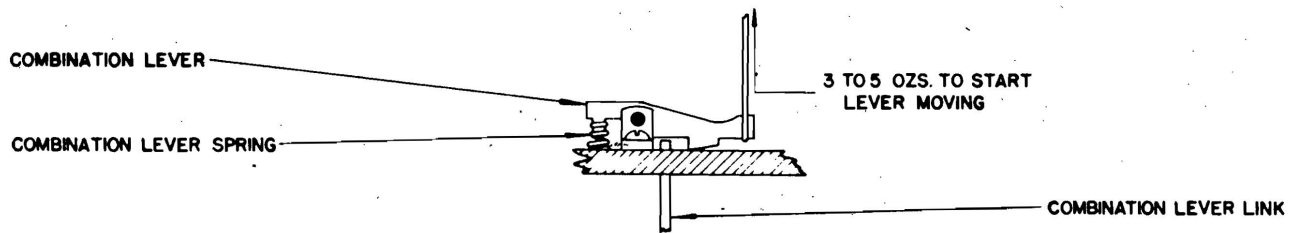

FIGURE 19

Punch Head Adjusting Screw Adjustment (Figure 20)

Connect the perforator to the proper power supply. With the key lever that will cause the floating lever to be stopped at the center of the locking rack, held depressed, there should be .010" to .015" clearance between the end of the locking wedge on the floating lever and the bottom of a notch in the locking rack.

To measure this clearance, hold depressed the key lever that will cause the floating lever to be stopped at the center of the locking rack; then insert a screw driver between the impact plate and a punch head stop screw, and move the punch head forward so that the locking rack is against the floating lever. While holding the punch head in this position, measure the clearance between the impact plate and the punch head adjusting screw.

To adjust, loosen the punch head adjusting screw lock nut and position the screw to obtain the specified clearance. Tighten the lock nut.

Feed Lever Advancing Screw Adjustment (Figure 21)

With the floating lever held to the extreme left and the space bar held operated, the feed pawl should withdraw from its stop screw a distance of 1-1/4 to 1-1/2 ratchet teeth on perforators where two spaces are required between words and a distance of 2-1/4 to 2-1/2 ratchet teeth on perforators where three spaces are required between words. With any key lever held depressed, the feed pawl should overtravel a tooth on the ratchet by .020" to .045". Try all key levers.

Adjust by means of the feed lever advancing screw and lock nut.

NOTE: The "Feed Lever Stop Screw Adjustment" which follows must be made in conjunction with the "Feed Lever Advancing Screw Adjustment" in order to secure the foregoing requirement.

Feed Lever Stop Screw Adjustment (Figure 21)

With the space bar held operated, there should be some clearance, not more than .002", between the steel face on the feed lever and the feed lever stop screw. With that key lever which selects the greatest number of punches held depressed, there should be some clearance, not more than .004", between the steel face on the feed lever and the feed lever stop screw.

Set the position of the feed lever stop screw, by means of its clamping screw, to meet the foregoing requirements, and recheck the "Feed Lever Advancing Screw Adjustment."

Feed Lever Retracting Screw Adjustment

There should be some clearance, not more than .008", between the punch head and the punch head adjusting screw when the feed lever is held by hand against its stop screw.

Adjust as follows: With the punch head in its unoperated position, hold the feed lever against its stop screw and adjust the feed lever retracting screw to obtain this requirement. (See Figure 21 for location of parts.)

NOTE: After making a single adjustment, check related adjustments.

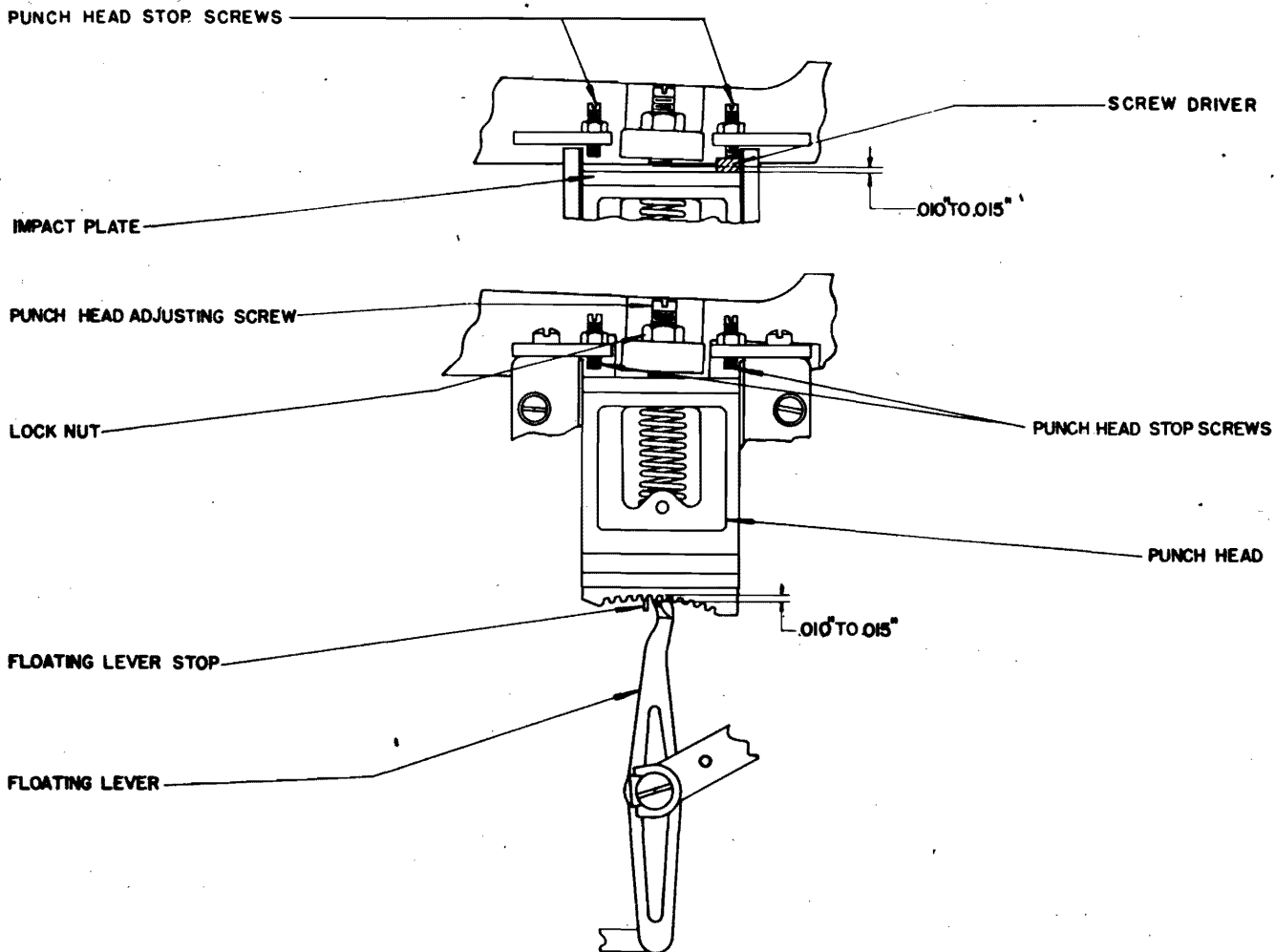

FIGURE 20

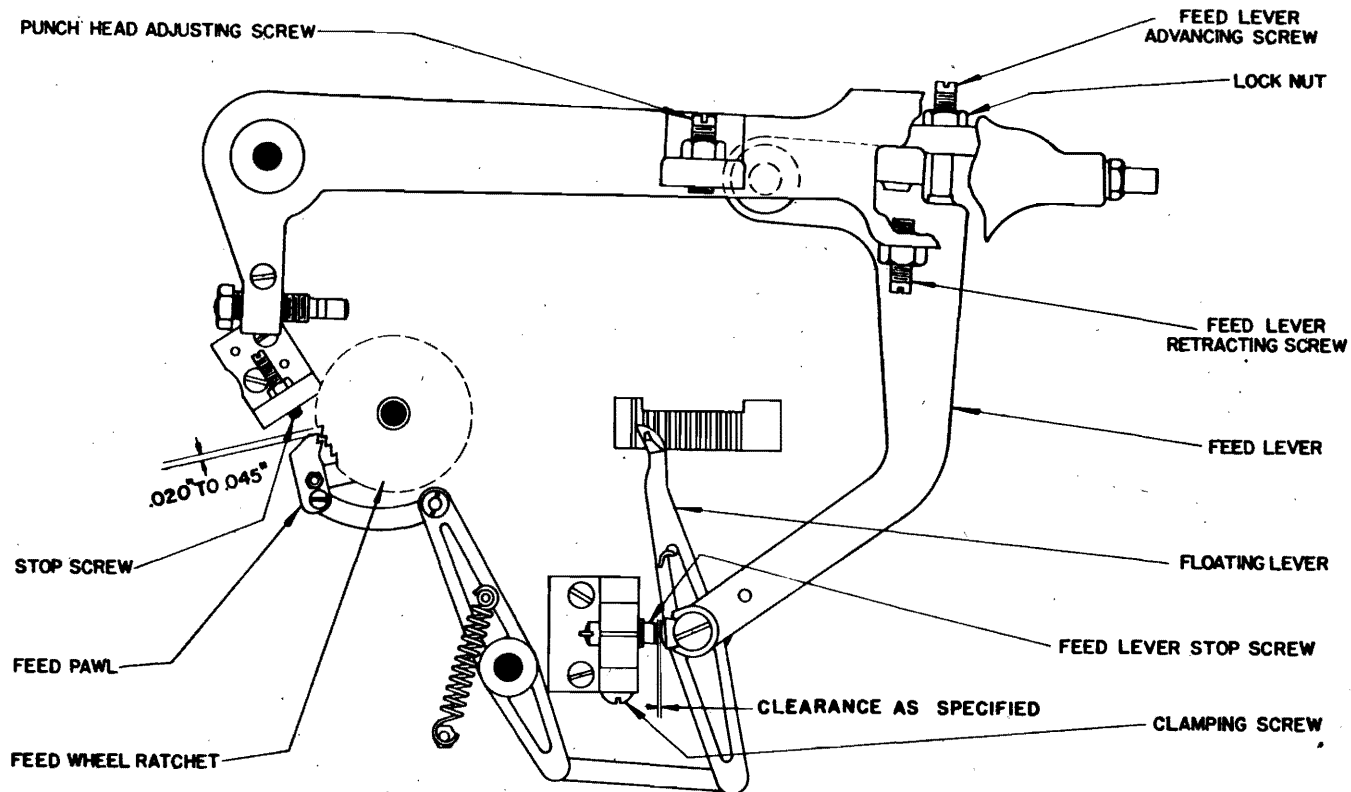

FIGURE 21

Bell Crank Stop Screw Adjustment

The bell crank should make contact with its stop screw at the same time that the floating lever makes contact with the floating lever backstop.

To adjust, loosen the bell crank stop screw lock nut and position the stop screw. Tighten the lock nut. (See Figure 14 and 22 for location of parts.)

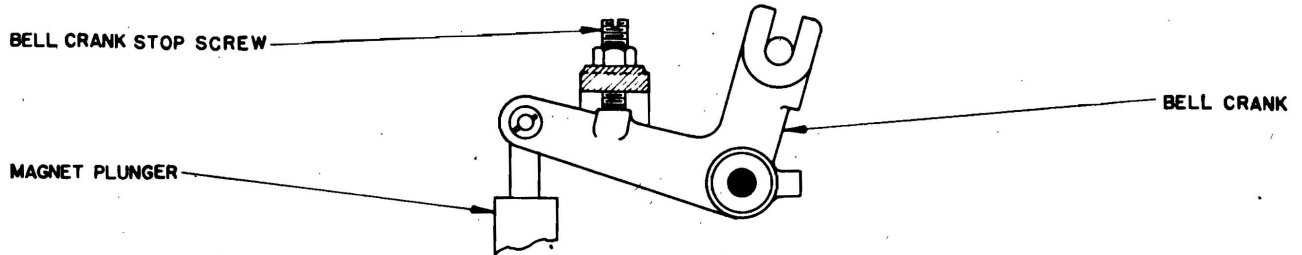

FIGURE 22

Punch Head Spring Tension Adjustment (Figure 23)

The punch head spring tension should be sufficient to allow the retracting comb to withdraw the punches from the tape after all the punches have been operated. When a 25 lb. scale is applied to the punch head casting, in line with the spring, a pull of not more than 18 lbs. should be required to start the punch head moving.

To adjust, insert tape in the die slot and partially release the tension on the punch head spring by backing off the spring adjusting screw. With all "T" bars except the power "T" bar held depressed, operate the punch head and hold it in the forward position. Then release all the "T" bars and allow the punch head to be withdrawn slowly by the spring. Increase the spring tension by means of the adjusting screw very gradually until the punches are suddenly withdrawn from the tape; then increase the spring tension three-quarters of a turn.

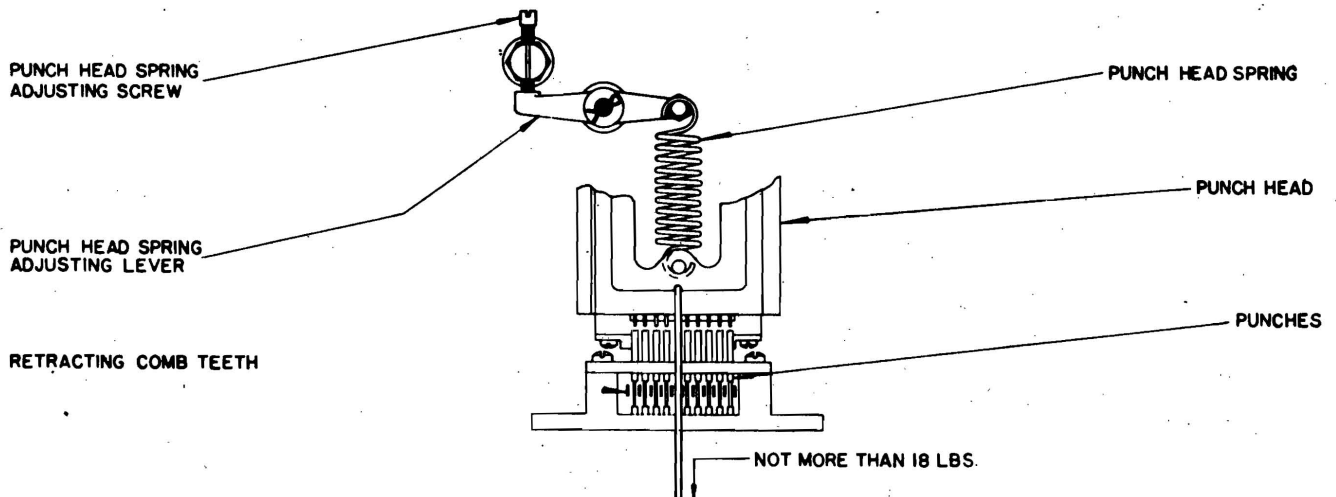

FIGURE 23

Main Lever Spring Tension (Figure 24)

With the floating lever held to the right, hook a 12 lb. scale in the fork of the bell crank and pull horizontally toward the front of the perforator. A pull of

NOTE: After making a single adjustment, check related adjustments.

2 to 4 lbs. should be required to start the main lever moving. This tension should be sufficient to return the floating lever to its backstop.

To adjust, loosen the main lever spring adjusting screw clamping screw and position the adjusting screw to obtain the proper tension. Tighten the clamping screw.

ON PERFORATORS EQUIPPED WITH TAPE REEL (CATALOGUE NO. 55418), THE FOLLOWING ADJUSTMENTS APPLY:

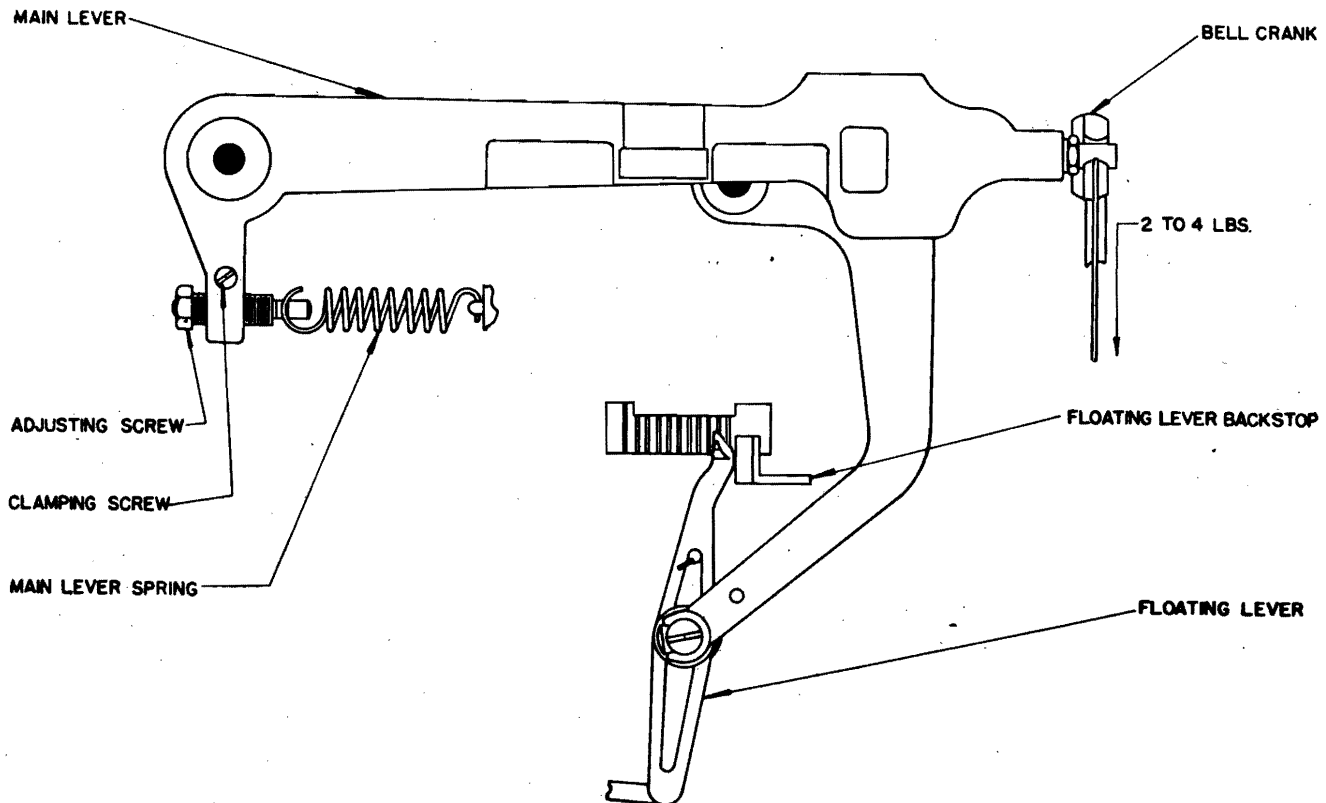

FIGURE 24

Tape Reel Stud Adjustment

When a roll of tape is placed in the tape reel, the lower edge of the tape on the reel should align with the bottom of the tape channel in the die block.

Adjust by means of the tape reel stud and lock nut.

Brake Arm Adjustment

The brake shoe should be positioned directly to the right of the bell crank stop screw, and the top of the brake shoe should align with the top of the tape reel.

To adjust, position the brake arm by bending.

Brake Arm Spring Torsion

With an 8 oz. scale held parallel to the brake arm and applied to the post on the brake shoe, a pressure of 1/2 to 1 oz. should be required to start the brake shoe moving away from the tape reel.

ON PERFORATORS EQUIPPED WITH A TAPE SHOCK ABSORBER, THE FOLLOWING SPRING TORSION APPLIES:

NOTE: After making a single adjustment, check related adjustments.

Shock Absorber Spring Torsion

Hook an 8 oz. scale over the shock absorber lever at the right tape roller and pull at right angles to the lever. It should require 1 to 2 ozs. to start the lever moving.

LUBRICATION SPECIFICATION

The oil and grease specified in the supplement furnished with this bulletin should be used to lubricate the perforator.

Unless otherwise specified, one or two drops of oil at each of the locations listed will be sufficient. Use oil for lubrication at all of the locations listed below, except where the use of grease is specified.

A. Locations on the Bottom Side of the Perforator

Shift key lever bearing screws - right and left.

Right and left shift links - front and rear ends.

Shift bracket shaft bearings - right and left.

Upper and lower "T" bar links - at right and left ends.

Connecting bars - at point of contact with "T" bars.

All helical tension spring loops.

B. Locations on the Top Side of the Perforator

"T" bars - at right and left guide comb slots.

Key levers - at fulcrum.

Selecting bars - at fulcrum and at points of contact with key bars and "T" bars.

Connecting bars - at fulcrum.

Power connecting bar - at fulcrum and guide slot.

Connecting links - at lower end.

Solenoid plunger oil tube.

Bell crank link - upper and lower connections.

Bell crank bearing screw.

Feed lever bearing screw.

Floating lever bearing screw.

Floating lever link - at both ends.

Intermediate lever bearing screw.

Feed pawl link - at both ends.

Feed wheel stud oil hole and ratchet teeth.

Combination lever pivot.

Combination lever link - upper and lower ends.

Pressure block pivot.

NOTE: After making a single adjustment, check related adjustments.

Pressure block arm pivot.

Feed wheel locking arm - pivot and roller.

Main lever oil hole.

Punch head slide.

Punch selector bars - at guide slots.

Punches - at front and rear guides.

All helical tension spring loops.

GREASE SHOULD BE APPLIED AT THE FOLLOWING LOCATIONS:

Right-hand end of main lever.

End of punch head adjusting screw.

End of feed lever retracting screw.

End of feed lever advancing screw.