

MODEL 32 ASR, KSR, AND RO
OPTIONAL FEATURES

CONTENTS	PAGE	CONTENTS	PAGE
1. GENERAL	1	I. 186185 Modification Kit — For Conversion of the Form Feed Rate of a Model 32 Sprocket Feed Typing Unit	12
2. OPTIONAL FEATURES	2	J. 186226 Modification Kit — Provides Mobility for a Model 32 Set	14
A. 180801 Coding and Installation of the Universal Function Lever	2	K. 186752 Modification Kit — Provides Locking of the Model 32 Keyboard	16
B. 183877 Through 183883 Modification Kits — Equips Model 32 Sprocket Feed Typing Unit Form Out for Handling Various Lengths of Forms	3	L. 186776 Modification Kit — Provides a Handle for a Model 32 Typing Unit	18
C. 184157 Modification Kit — Provides Model 32 Friction Feed Typing Unit With Automatic Line Feed on Carriage Return	4	M. 194822 Directory Holder for Model 32 KSR and ASR Cabinets	19
D. 185705 Modification Kit — Provides Model 32 ASR With a Tape Guide for Folded Tape	6	N. 333521 Set of Parts — Provides AC Motor and Governor Assembly to be Used in Driving Model 32 Apparatus in Locations Where Regulated 50/60 Hertz Frequency Alternating Current is Not Available	19
E. 183859 Modification Kit — Provides Model 32 Cabinet With a Paper Supply Bin and Accumulating Shelf	7		
F. 185791 Modification Kit — Provides Operator-Controlled Single or Double Line Feed Feature on a Model 32 Friction Feed Typing Unit	8	1. GENERAL	
G. 185971 Modification Kit — Provides Model 32 Typing Unit With a Margin Bell to Ring on Approximately the 61st Character	9	1.01 This section provides the description and operation, adjustments, lubrication, and disassembly and reassembly information for the optional features and modification kits that are available for use on the various components and units that comprise a Model 32 Set.	
H. 185983 Modification Kit — Adds Carriage Return on Line Feed to a Model 32 Typing Unit	11	1.02 The adjustments covered in this section apply only to those adjustments that are peculiar to a particular modification kit or optional feature. Other adjustments that are affected when a modification kit is installed are referenced by title and section number.	

SECTION 574-160-105TC

1.03 The lubrication procedures to be followed and the type of lubricants to be used are the same as outlined in standard Model 32 lubrication sections.

1.04 Disassembly and reassembly as outlined in this section covers the procedure for removing and replacing the individual parts that make up a particular modification kit or optional feature. Where it is felt that additional disassembly and reassembly information is needed, reference is made to the appropriate sections and specifications.

1.05 For some modification kits, adjustment, lubrication, or disassembly and reassembly information does not appear. In these cases none is required.

2. OPTIONAL FEATURES

A. 180801 Coding and Installation of the Universal Function Lever

Description

2.01 The 180801 universal function lever has no marking or spacing tines removed. This allows the customer the option of removing tines to either code the function lever to respond to "nonstandard" code combinations, or to replace damaged function levers.

2.02 The tines of the 180801 function lever (Figure 1) are numbered from right to left as follows: PS, 0, 1, 2, 3, 4, 5, 6, 7.

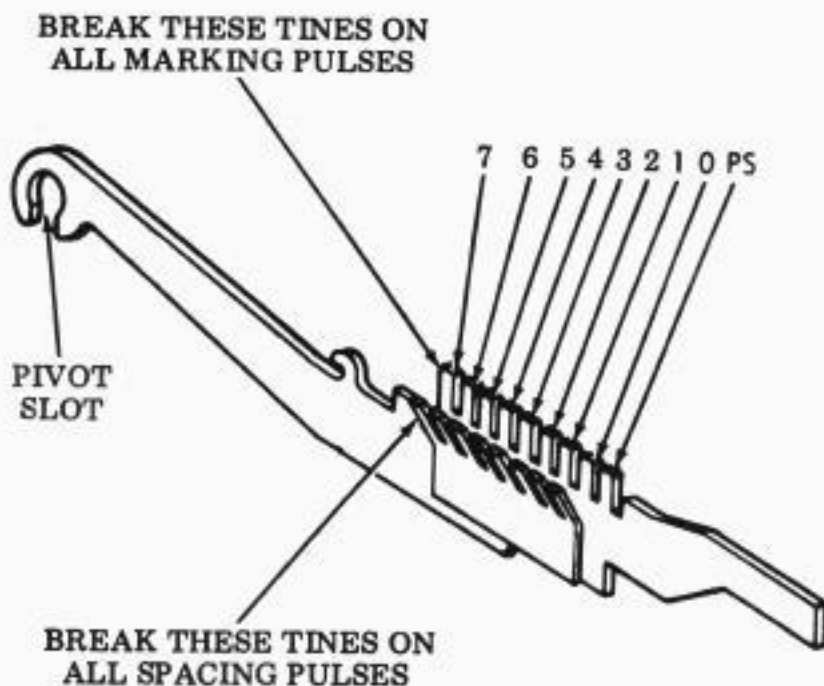

Figure 1 - 180801 Universal Function Lever

2.03 There are two rows of tines on the universal function lever. The straight row of tines corresponds to the marking pulses of a given code combination; the slanted row of tines corresponds to the spacing pulses of a given code combination.

Coding

2.04 Choose the code combination the function lever is to respond to and break off the straight tine whose number corresponds to the marking pulses in the desired code. Break off the slanted tines whose number corresponds to the spacing pulses in the desired code.

2.05 If a tine tool is not available, the tines on the universal function lever are easily broken off with long-nose pliers.

2.06 Break the PS (Print Suppression) tine when printing is desired. The "0" tine represents the shift level. Where upper case (figures) is part of the code, break the straight "0" tine. For lower case (letters), break the slanted "0" tine.

2.07 Since codebars do not exist in the Model 32 typing unit for the number 6 and 7 tines, these tines do not have to be broken.

Installation

2.08 The 180801 universal function lever is to be installed only in the numbered slots of the function casting, such as 3, 4, 5, 6, etc. Do not install the universal function lever in the lettered slots of the function casting, such as B, C, D, E, F, etc.

2.09 To install the universal function lever, proceed as follows:

(a) If the typing unit is equipped with a function lever retainer, lower the retainer sufficiently to allow the universal function lever to be installed under the codebar basket. Readjust the function lever retainer.

(b) Place the universal function lever under the codebar basket with the open end of the pivot slot on the pivot shaft.

(c) While holding the lever in place, squeeze it onto the pivot shaft with a pair of pliers. This is a "snap" fit and sufficient pressure should be applied with

the pliers to seat the lever fully on the shaft. The lever should pivot freely once on the shaft.

(d) Locate the proper numerical slot on the function casting, place the lever in the slot, and install the 186669 spring.

B. 183877 Through 183883 Modification Kits
 — Equips Model 32 Sprocket Feed Typing Unit Form Out for Handling Various Lengths of Forms

Description and Operation

2.10 The modification kits provide parts for changing the cam lobes, spur gear, and gear w/gear on the form out mechanism of the sprocket feed typing unit that will enable the typing unit to accommodate various paper form lengths (see Figure 2).

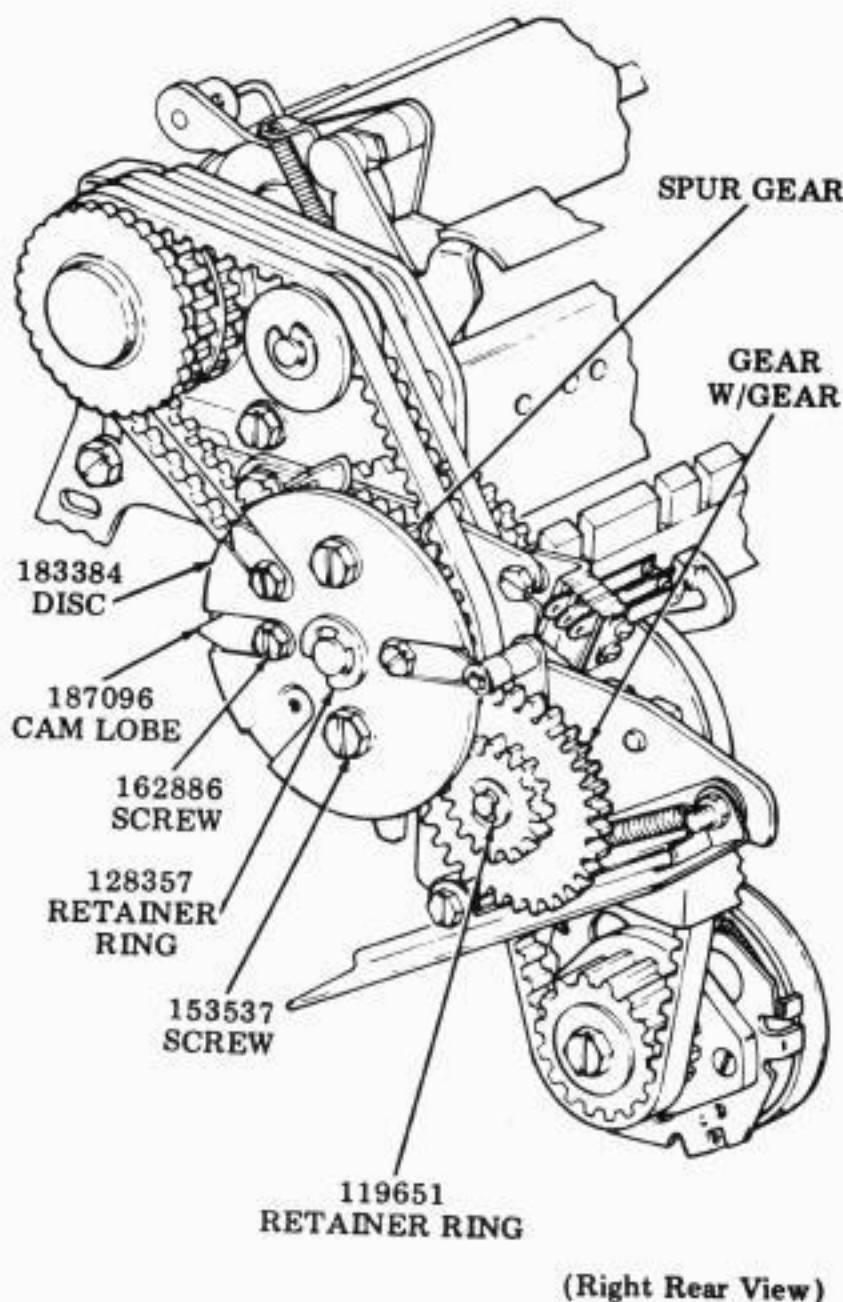

Figure 2 - Form Out Mechanism

2.11 The modification kits and the form lengths they will handle are shown in the following chart. The chart also shows how many cam lobes are included in each kit with the resulting length of form out when these cam lobes are installed. Figure 3 shows the various positions of the cam lobes.

Modification Kit	No. of Cam Lobes Used		
	1	2	3
	Form Lengths (In Inches)		
183877	11	5-1/2	3-2/3
183878	9	4-1/2	3
183879	7	3-1/2	2-1/3
183880	8	4	2-2/3
183881	8-1/2	—	2-5/16
183882	10	5	3-1/3
183883	6	—	—

Adjustments

2.12 After installation of any of the modification kits, perform the following adjustments as outlined in Section 574-172-700TC: Cam Lobe Position (FOA-8), Reset Follower Lever — Reset Position (FOA-30), and Cam Zero Position (FOA-31, 32, 33, and 34).

Lubrication

2.13 Follow the lubrication requirements as outlined for cam, pulley and gear combination, and form out mechanism in Section 574-172-701TC.

Disassembly and Reassembly

2.14 Disassembly and reassembly is necessary when a change from one form length to another is required. The change is accomplished by merely changing the spur gear, the gear w/gear, and the number of cam lobes. Refer to Figure 2 and proceed as follows:

- (a) Remove the typing unit from the sub-base as outlined in Section 574-160-702TC covering removal and replacement of components.
- (b) Remove the 128357 retainer ring and pull off 183384 disc to which a spur gear and cam lobes are secured by screws.
- (c) Remove the 187096 cam lobes from the 183384 disc by removing the 162886 screws.

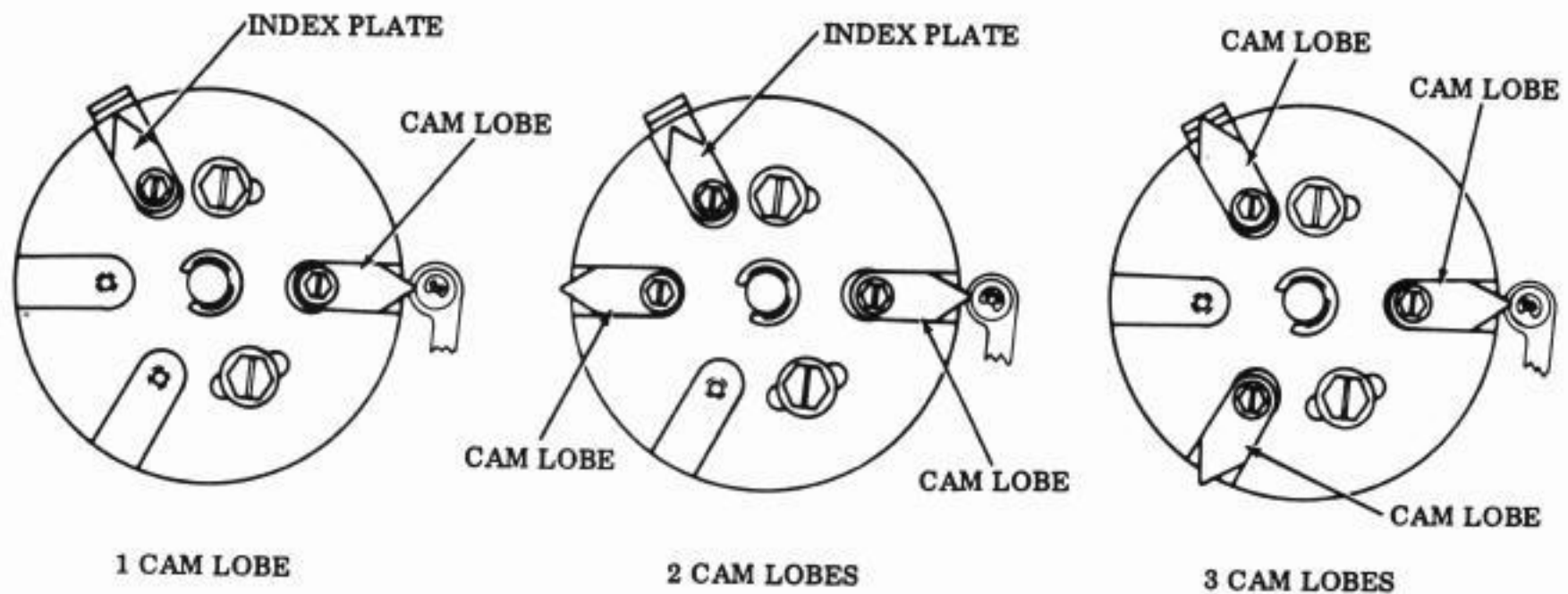

Figure 3 - Position of Cam Lobes

- (d) Disassemble the spur gear from the 183384 disc by removing two 153537 screws.
- (e) Remove the 119651 retainer ring and pull off the gear w/gear.
- (f) To reassemble (with the same gears or with different gears), reverse the disassembly procedure.

Install proper number of cam lobes per Figure 2.

C. 184157 Modification Kit — Provides Model 32 Friction Feed Typing Unit With Automatic Line Feed on Carriage Return

Description and Operation

2.15 The installation of this modification kit, which consists of a spring and function lever, will enable the typing unit to line feed automatically when the operator depresses the carriage return button.

2.16 Upon receiving the carriage return code combination, the 180793 carriage return function lever (see Figure 4) moves upward to its selected position. In doing so, it engages the extended tab of the 183499 blocking lever and causes it to move up also. As the blocking lever rises, it engages the latching surface of the 181500 line feed drive link. During the middle portion of the cycle, the carriage return lever and the line feed drive link are driven downward causing both functions to occur simultaneously.

Adjustments

2.17 After installation of the modification kit, check and remake the following adjustments as outlined in Section 574-172-700TC: Line Feed Drive Arm Clearance (PLA-5) and Line Feed Upstop Bracket Position (PLA-6).

Lubrication

2.18 Follow standard lubrication requirements as outlined in Section 574-172-701TC.

Disassembly and Reassembly

2.19 Refer to Specification 50413S and Section 574-172-800TC for parts identification and proceed as follows:

- (a) Remove cover as outlined in Section 574-160-702TC.
- (b) Remove typing unit from subbase as outlined in Section 574-160-702TC covering removal and replacement of components.
- (c) Turn typing unit on its left side and unhook 84226 spring from 181500 drive link.
- (d) Unhook 101386 spring from 183499 blocking lever and 181503 guide bracket.

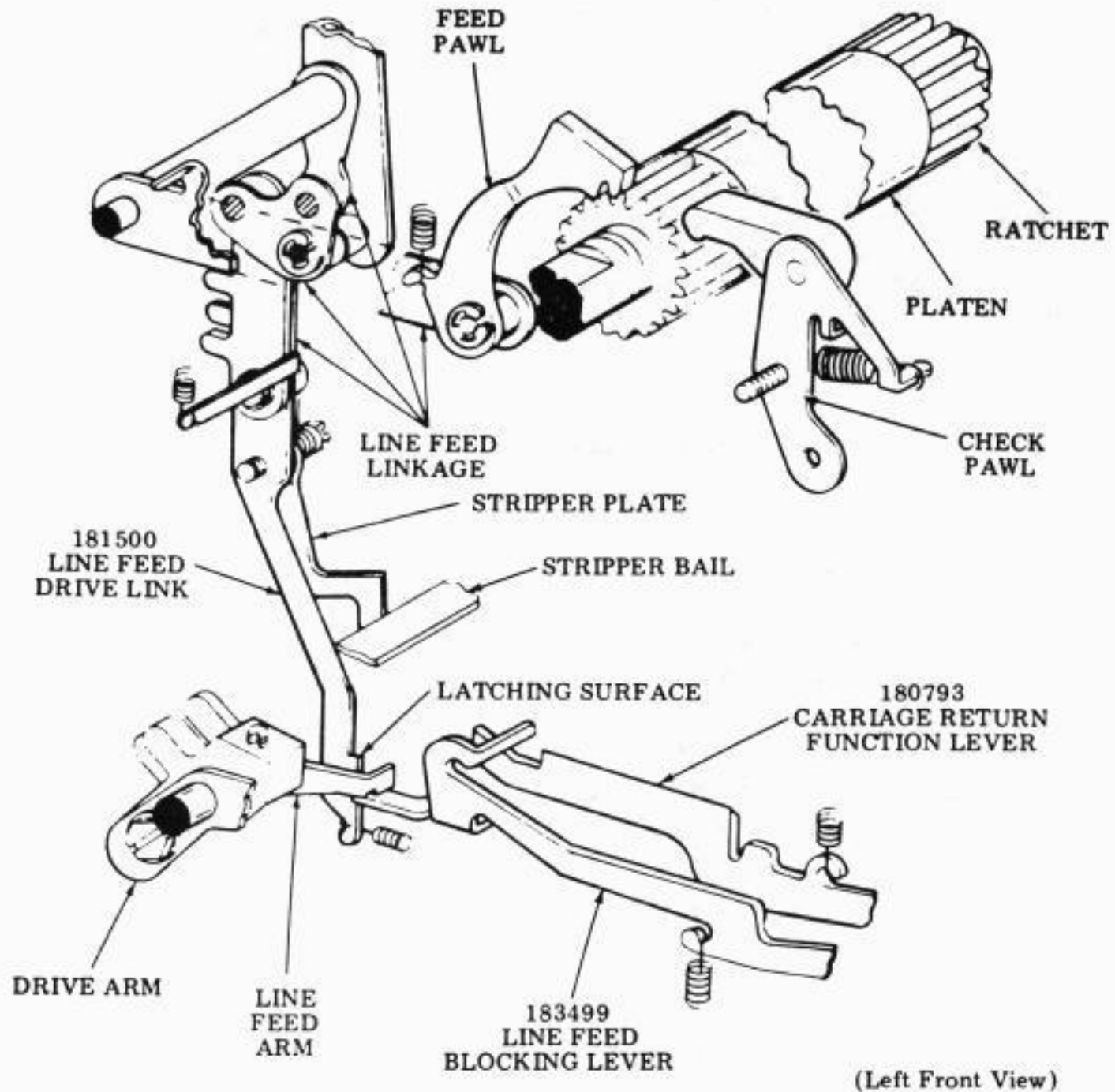

Figure 4 - Paper Feed Mechanism

(e) Remove the 181503 guide bracket by removing the two 181240 screws that secure the bracket to the 180769 left link.

(f) Place typing unit upright and loosen the three 180798 screws that secure two 180797 clamps and a 180795 spring bracket so that the 180782 shaft can be rotated freely.

CAUTION: IN REMOVING A FUNCTION LEVER, ROTATE SHAFT NO FARTHER THAN NECESSARY. IF THE SHAFT IS ROTATED TOO FAR, OTHER FUNCTION LEVERS WILL COME OFF. IN THIS EVENT, IT WILL BE NECESSARY TO REMOVE THE SPRINGS FROM

THOSE FUNCTION LEVERS AND REPOSITION THE LEVERS ON THE 180782 SHAFT TO THEIR ORIGINAL POSITIONS.

(g) Unhook 101386 spring from 180793 carriage return function lever and allow the function lever and the 183499 line feed blocking lever to drop.

(h) Remove the 183499 blocking lever by applying slight upward pressure to it at a point just in rear of the 180782 shaft while slowly rotating the flat side of the shaft toward the front of the typing unit until the blocking lever lifts off.

(i) To replace the parts, reverse the procedure used to remove them.

SECTION 574-160-105TC

D. 185705 Modification Kit — Provides Model 32 ASR With a Tape Guide for Folded Tape

Description and Operation

2.20 This modification kit enables the Model 32 ASR to accommodate folded tape by providing a bracket (see Figure 5) which is attached to the punch block between the tape feed roller and the punch block, and a tape depressor which straddles the tape feed roller above the tape.

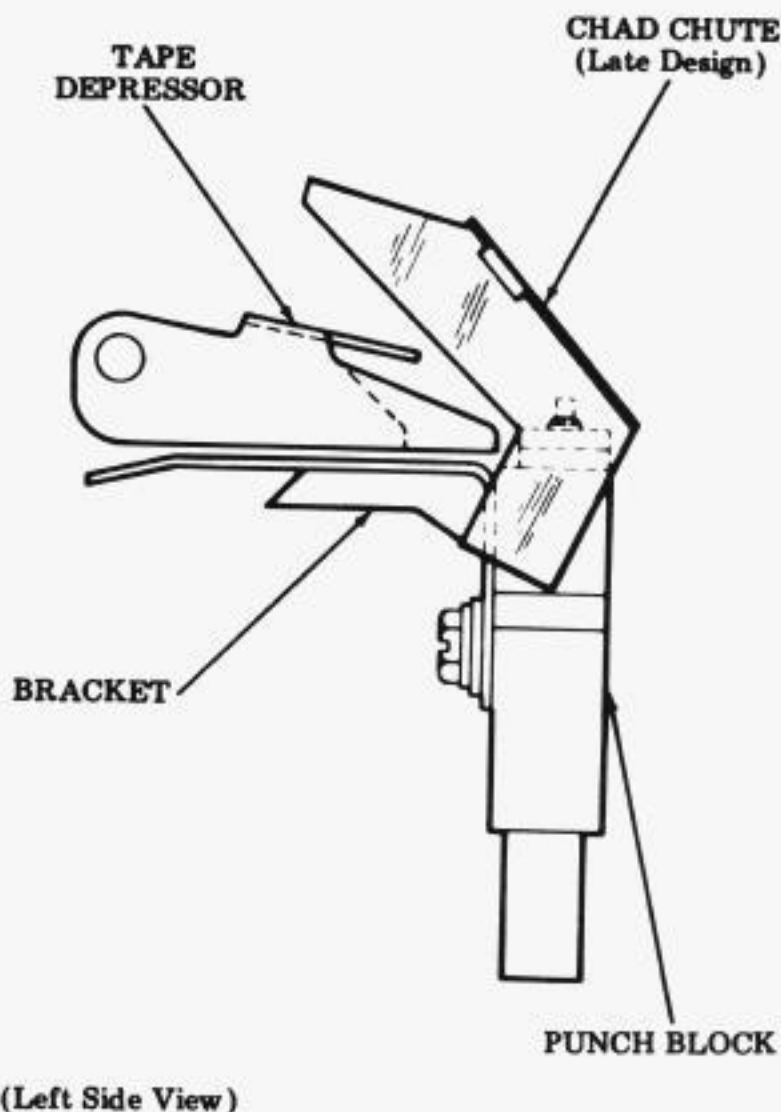

(Left Side View)

Figure 5 - Tape Guide for Prefolded Tape

2.21 When folded tape is fed through the punch, the tape depressor prevents the tape from buckling upward or downward and jamming the punch block.

Adjustments

2.22 The adjustments (Figure 6), apply to tape punches equipped with either the early design or late design chad chute.

(1) Requirement
With no tape in punch, bracket should be flush with top surface of punch block casting.

To Adjust
Loosen screw and position bracket.
Tighten screw.

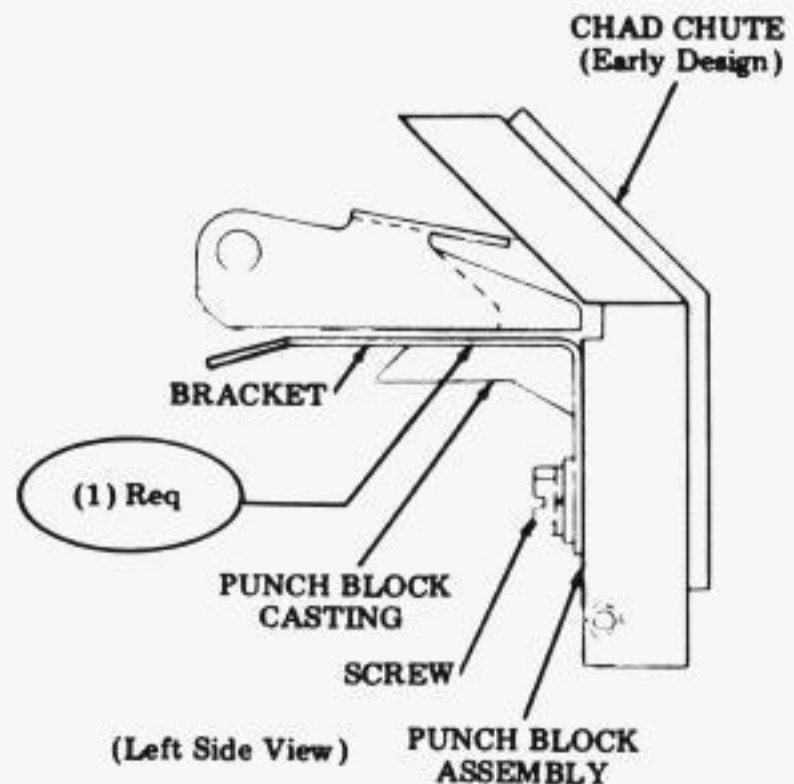

(2) Requirement
With tape in punch
Min some — Max 0.015 inch
between tape depressor tab and under-
side of chad chute.

To Adjust
Bend tape depressor tab.

Note: Check Ten Characters Per Inch adjustment and refine if necessary (refer to Section 574-175-700TC).

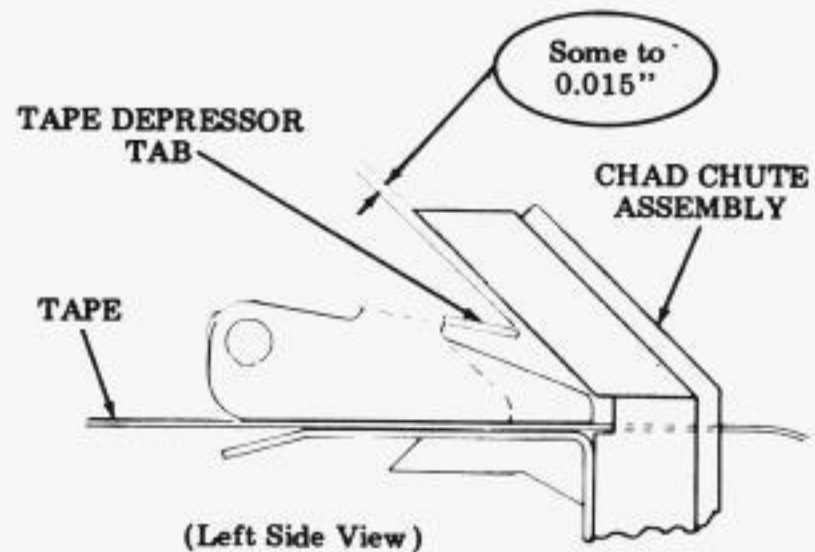

Figure 6 - Folded Tape Guide Adjustment

Lubrication

- 2.23 Refer to Figure 7 for lubrication of the tape guide for folded tape.

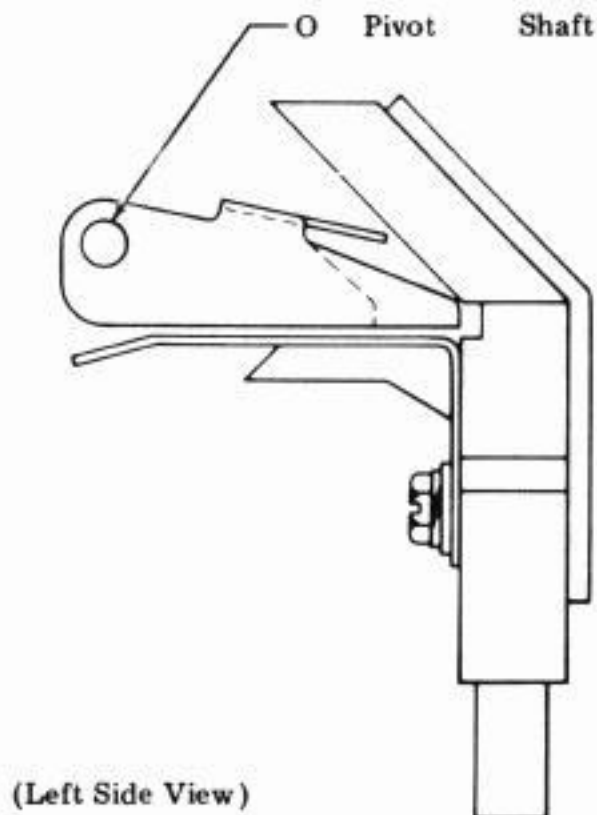

Figure 7 - Tape Guide Lubrication

Disassembly and Reassembly

- 2.24 Remove cover as outlined in Section 574-160-702TC covering removal and replacement of components.
- 2.25 For parts identification, refer to parts drawings in Section 574-175-800TC, and proceed as follows:
- Remove the 182915 extension.
 - Remove the 182908 chad chute (early design) by removing two 151152 screws, 110743 lockwashers, and 2034 flat washers; or remove the 185891 chad chute (late design) by removing two 185890 push nuts and 186582 flat washers.
 - Remove the two 119649 retaining rings securing the 182800 shaft that contains the 182857 roller and 185704 tape depressor.
 - Disassemble the 182857 roller and 185704 tape depressor from the shaft by removing the remaining two 119649 retaining rings.
 - Remove the 185706 bracket by removing the 151152 screw, 110743 lockwasher, and 125011 flat washer.
 - To replace the parts, reverse the procedure used to remove them.

E. 183859 Modification Kit — Provides Model 32 Cabinet With a Paper Supply Bin and Accumulating Shelf

Description

- 2.26 When installed (see Figure 8), the modification kit provides a cabinet with a means of storing forms prior to and during operation of the printer, and also accumulating these forms after they have been typed.

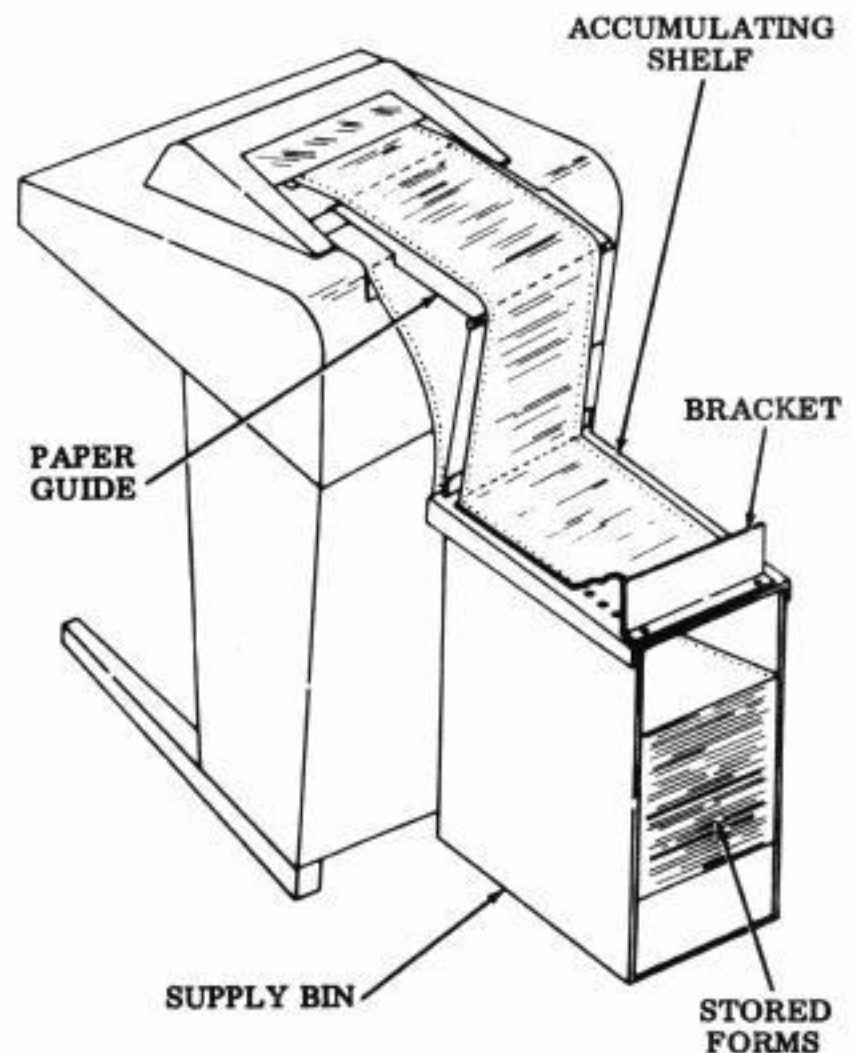

Figure 8 - Accumulating Shelf and Supply Bin

- 2.27 The modification kit will accumulate folded form stationery 8-1/2 inches in width and from 6 inches to 12 inches in length. The forms feed from inside the bin and are routed under the shelf, paper guide, and platen mechanism. The printed forms are accumulated on the shelf.

SECTION 574-160-105TC

2.28 The accumulating shelf can accommodate various lengths of forms by positioning the bracket at various points on the shelf.

Adjustments

2.29 Refer to Figure 9 for accumulating shelf adjustment.

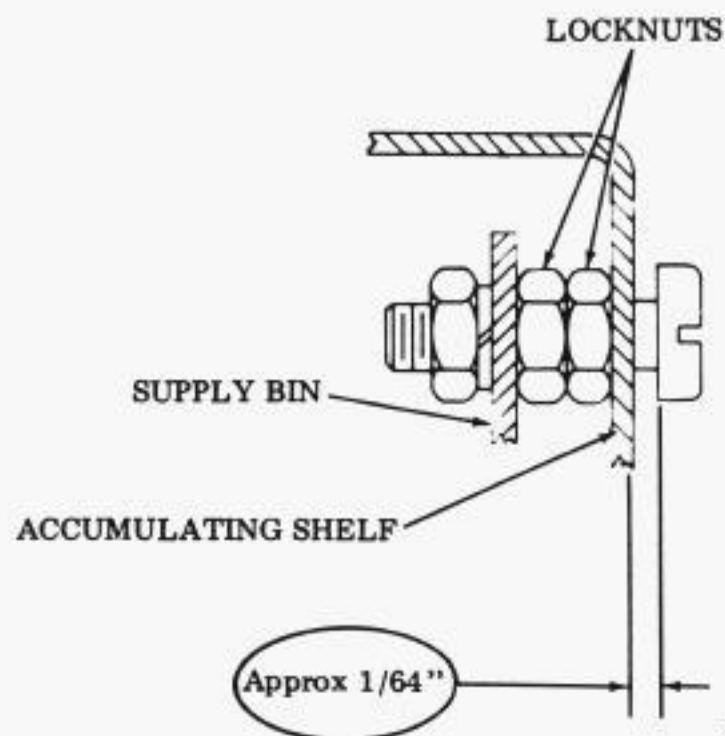

Requirement

The accumulating shelf should pivot freely on the supply bin. There should be
Approx 1/64 inch
clearance.

To Adjust

Position the two locknuts to meet this requirement.

Figure 9 - Accumulating Shelf Adjustment

Disassembly and Reassembly

2.30 Refer to Section 574-176-800TC for parts identification and proceed as follows:

- (a) Remove the 184159 backstop bracket by removing two 151657 screws, two 3598 nuts, and two 2191 lockwashers.
- (b) Remove the 183860 spring clip by removing the 185707 screw.

(c) Remove the 183856 paper guide by removing two 3598 nuts, two 2191 lockwashers, and two 103084 flat washers.

(d) Remove the 183855 plate w/hinges by removing two 151657 screws, two 3598 nuts, and two 2191 lockwashers.

(e) Remove the 183857 paper shelf by removing two 151659 screws, six 3598 nuts, and two 2191 lockwashers.

(f) Remove the four 183854 feet from the bottom of the 183858 paper supply bin by removing four 2263 nuts and four 3646 lockwashers.

(g) To replace the paper supply bin and accumulating shelf, reverse the procedure used to remove them.

F. 185791 Modification Kit — Provides Operator-Controlled Single or Double Line Feed Feature on a Model 32 Friction Feed Typing Unit

Description and Operation

2.31 The installation of this modification kit will enable the operator to manually shift into either a single or double line feed mode. This modification kit is not compatible with early design typing units using the 181041 retainer on the 181034 platen. Early design typing units may be modified to be compatible with the modification kit by replacing the early design 181034 platen and adding the late design retainer parts (185816 screw and 3606 nut). See parts drawings in Section 574-172-800TC.

2.32 The modification kit provides the typing unit with a movable line feed pawl upstop stud (see Figure 10). The stud is fixed to a movable arm that is detented by the operator into either one of two detents to obtain single or double line feed. The upper detent is for single line feed and the lower detent is for double line feed. Each detent is stamped with a numeral corresponding to its functional position. Shifting from one mode of operation to the other is accomplished by applying a slight sideways force to the detent plate extension in a direction away from the shift lever arm and positioning the shift lever arm up for single line feed or down for double line feed.

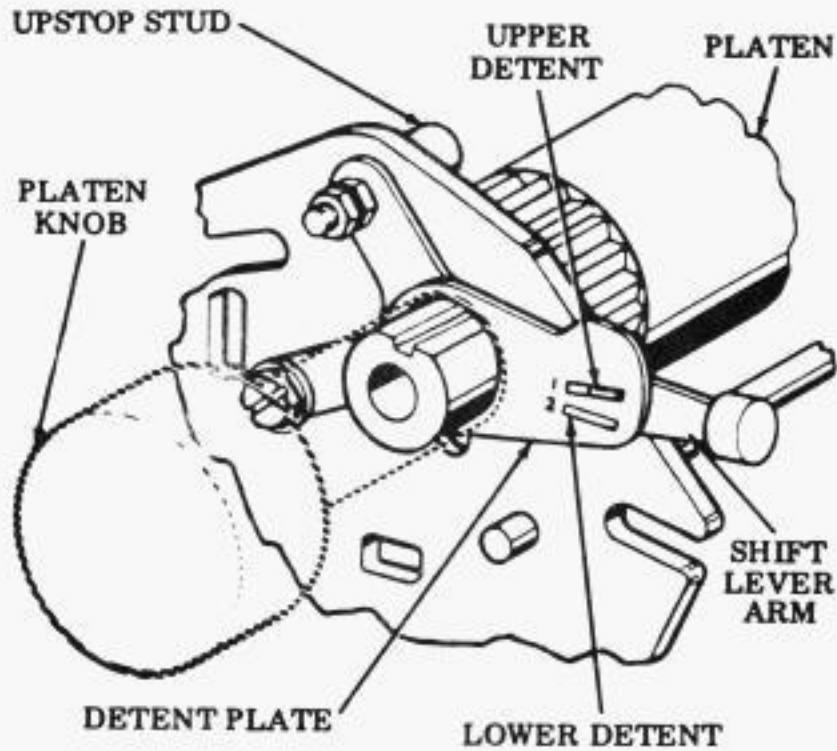
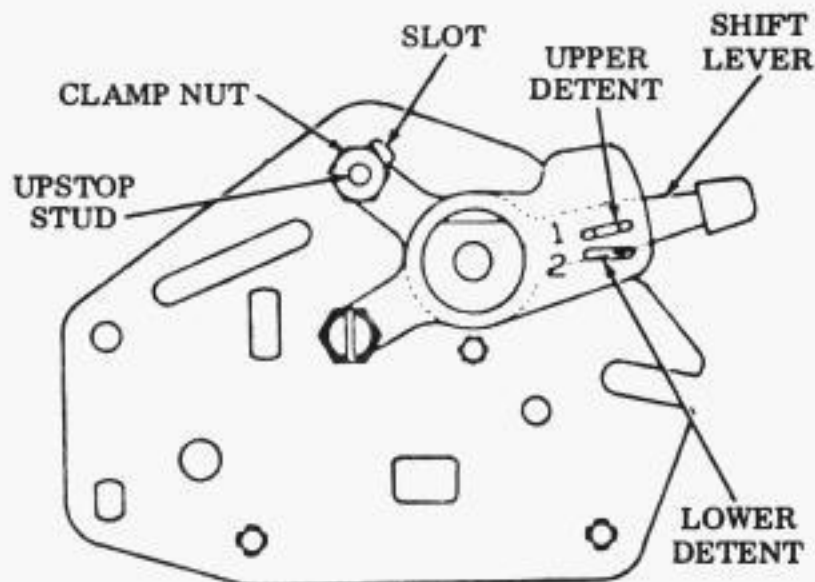

Figure 10 - Single or Double Line Feed Feature

Adjustments

- 2.33 Refer to Figure 11 for line feed selection adjustment.



(Left Side View)

Requirement

Upstop stud should be at bottom of slot when shift lever is placed in upper detent for single line feed or at top of slot when shift lever is placed in lower detent for double line feed.

To Adjust

Loosen clamp nut friction tight. Position upstop stud. Tighten clamp nut.

Figure 11 - Line Feed Selection Adjustment

Lubrication

- 2.34 See Figure 12 for line feed selection lubrication.

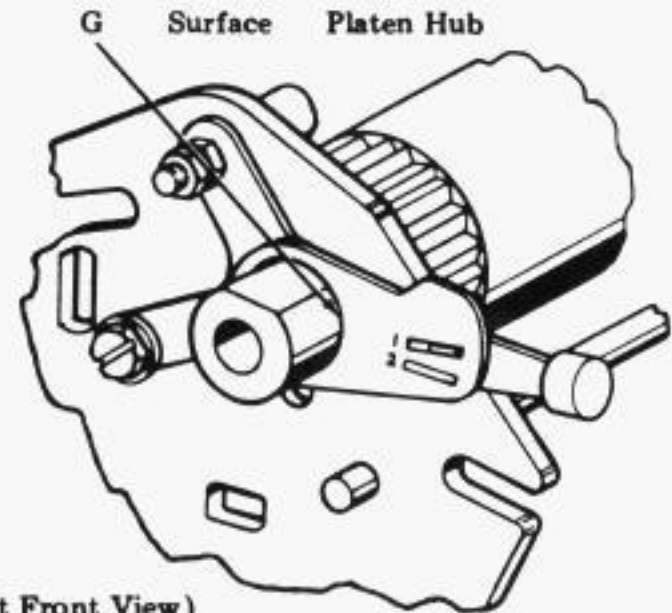

(Left Front View)

Figure 12 - Line Feed Selection Lubrication

Disassembly and Reassembly

- 2.35 For parts identification, refer to parts drawings in Section 574-172-800TC and proceed as follows:

- (a) Remove all power from unit.
 - (b) Remove cover as outlined in Section 574-160-702TC.
 - (c) Remove the 181039 platen knob.
 - (d) Remove the 181241 screw and associated 76461 flat washer.
 - (e) Remove the 185790 detent plate.
 - (f) Remove the 185789 stud and associated 3599 and 110435 nuts.
 - (g) Remove the 185788 arm.
 - (h) To replace the parts, reverse the procedure used to remove them.
- G. 185971 Modification Kit — Provides Model 32 Typing Unit With a Margin Bell to Ring on Approximately the 61st Character

Description and Operation

- 2.36 With the modification kit installed, a margin bell signal will ring when the printer carriage is at approximately the 61st

printing position. If the typing unit is equipped with automatic line feed carriage return, the 183498 margin bell codebar must be replaced with one of the following: a 183495 codebar for a 69-character line, a 183496 codebar for a 72-character line, or a 183497 codebar for a 74-character line.

2.37 When printing is begun and the carriage moves a sufficient distance to the right, the carriage upper-rear roller (see Figure 13) depresses a latch mounted on the carriage rear rail. The latch which remains depressed for one to two characters, pivots a lever which moves the margin bell codebar to the right. When the margin bell codebar is in this right side position, a function lever senses a notch in the lower edge of the margin bell codebar and picks up a special function pawl. This pawl moves the adjacent pawl which has a clapper loosely fixed to it. The pawl w/clapper is driven downward by the motion of the function lever. A stripper bail then strips the function pawl allowing it to move upward under its associated spring tension until it hits an upstop. Due to its loose fit, the clapper dynamically continues its upward motion and strikes a gong. The impact drives the clapper free of the gong, allowing the gong to ring undamped.

Adjustments

2.38 After installation of the modification kit, perform the following adjustments as outlined in Section 574-172-700TC: Rear Rail Position (CRA-4), Rear Roller Clearance (CRA-5), and Margin Bell Bellcrank Clearance (MDA-7).

Lubrication

2.39 Follow the lubrication requirements as outlined for Carriage Rear Rail and Codebars in Section 574-172-701TC.

Disassembly and Reassembly

2.40 For parts identification, refer to Section 574-172-800TC and Specification 50342S, and proceed as follows:

- (a) Remove all power from unit.
- (b) Remove cover as outlined in Section 574-160-702TC.
- (c) Remove the 22746, 180956, and 180922 codebar springs.

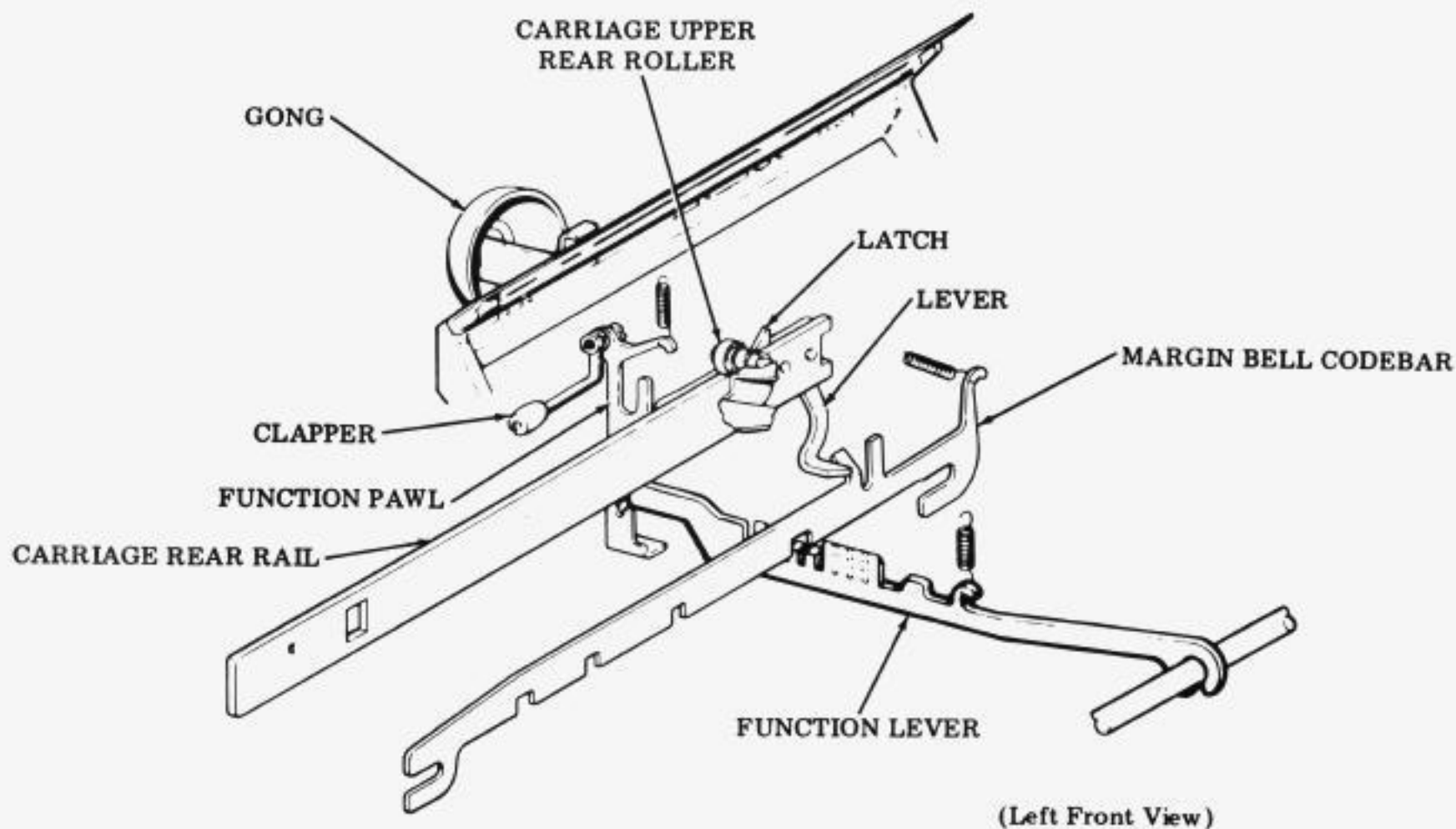

Figure 13 - Margin Bell Signal

- (d) Remove the 180921 spring bracket.
- (e) Remove the 183498 codebar.
- (f) Remove the 151650 screw, 124177 lockwasher, and 90790 flat washer.
- (g) Remove the 185970 lever.
- (h) Remove the 185969 hub.
- (i) Remove the 121923 spring.
- (j) Remove the 185968 latch.

Note: Some difficulty may arise in removing the above parts from sprocket feed printers. In this case remove the 180788 carriage rear rail.

- (k) Remove the 3598 nut and 124177 lockwasher.
- (l) Remove the 185986 eccentric post.
- (m) Remove the 119649 and 119652 retaining rings.
- (n) Remove the 185987 roller.
- (o) To replace the parts, reverse the procedure used to remove them.

H. 185983 Modification Kit — Adds Carriage Return on Line Feed to a Model 32 Typing Unit

Description and Operation

2.41 The installation of this modification kit will enable the carriage to return to the left-hand margin automatically when the operator depresses the line feed button.

2.42 Upon receiving the line feed code combination, the 185984 line feed lever senses the combination (see Figure 14) and moves upward to its selected position carrying the 181179 blocking lever with it by engaging its extended tab. As the line feed lever moves upward, the 185985 automatic carriage return lever, which was held down by the tab on the line feed lever, also begins moving upward picking up the 181325 pawl. The motion of this pawl is transferred to the 181322 carriage return pawl through its extension; thus, line feed and automatic carriage return occur simultaneously.

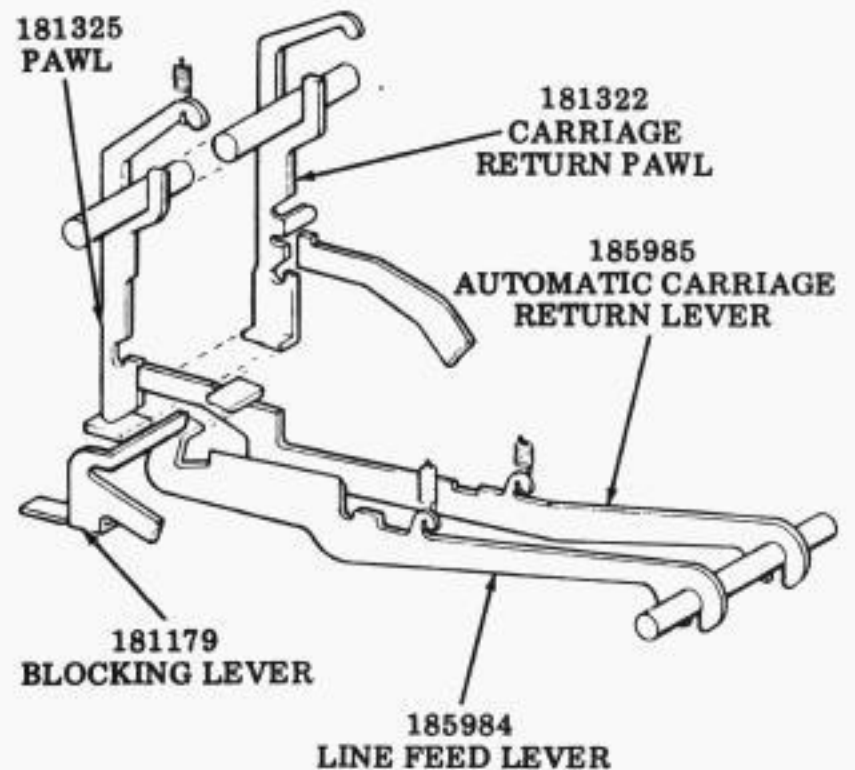

Figure 14 - Carriage Return Function on Line Feed

Adjustments

2.43 After installing the modification kit, perform the following adjustments as outlined in Section 574-172-700TC: Line Feed Drive Arm Clearance (PLA-5) and Line Feed Upstop Bracket Position (PLA-6).

Lubrication

2.44 Follow standard lubrication requirements as outlined in Section 574-172-701TC.

Disassembly and Reassembly

2.45 Refer to Section 574-172-800TC for parts identification and proceed as follows:

- (a) Remove cover as outlined in Section 574-160-702TC.
- (b) Remove typing unit from subbase as outlined in Section 574-160-702TC.
- (c) Unhook the 101386 spring from the 185984 line feed lever in slot "one" and allow lever to drop.
- (d) Unhook the 186669 spring from the 185985 lever in slot "A" and allow lever to drop.

(e) Loosen the three 180798 screws that secure two 180797 clamps and a 180795 spring bracket so that the 180782 shaft can be rotated freely.

(f) Remove the 185984 line feed lever by applying slight upward pressure to it at a point just in rear of the 180782 shaft while slowly rotating the flat side of the shaft toward the front of the printer until the line feed lever lifts off.

CAUTION: ROTATE SHAFT NO FARTHER THAN NECESSARY. IF THE SHAFT IS ROTATED TOO FAR, OTHER FUNCTION LEVERS WILL COME OFF. IN THIS EVENT IT WILL BE NECESSARY TO REMOVE THE SPRINGS FROM ALL FUNCTION LEVERS AND REPOSITION THE LEVERS ON THE SHAFT TO THEIR ORIGINAL POSITIONS.

(g) Remove the 185985 lever using the same procedure as outlined in (f).

Note: It may be necessary to lower the 183851 left retainer to facilitate removal of the levers. Should this be done, refer to the appropriate adjustment section for readjustment of the retainer.

(h) Remove the 86283 spring from the 181325 pawl in slot "A" and remove the pawl.

(i) To replace the parts, reverse the procedure used to remove them.

I. 186185 Modification Kit — For Conversion of the Form Feed Rate of a Model 32 Sprocket Feed Typing Unit

Description and Operation

2.46 This modification kit provides parts for changing the pulleys w/gears, stop discs, and line feed bail (see Figures 15 and 16)

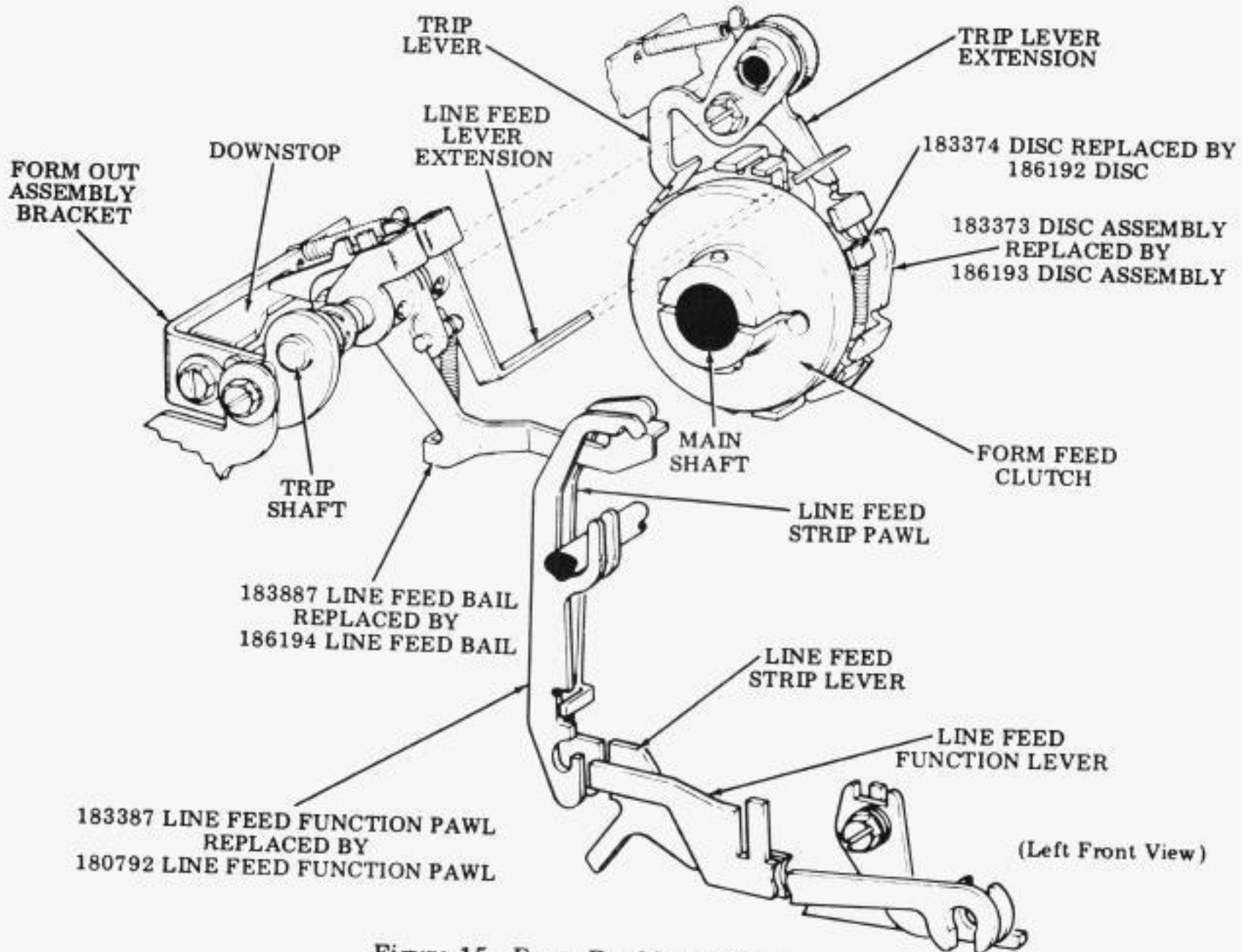
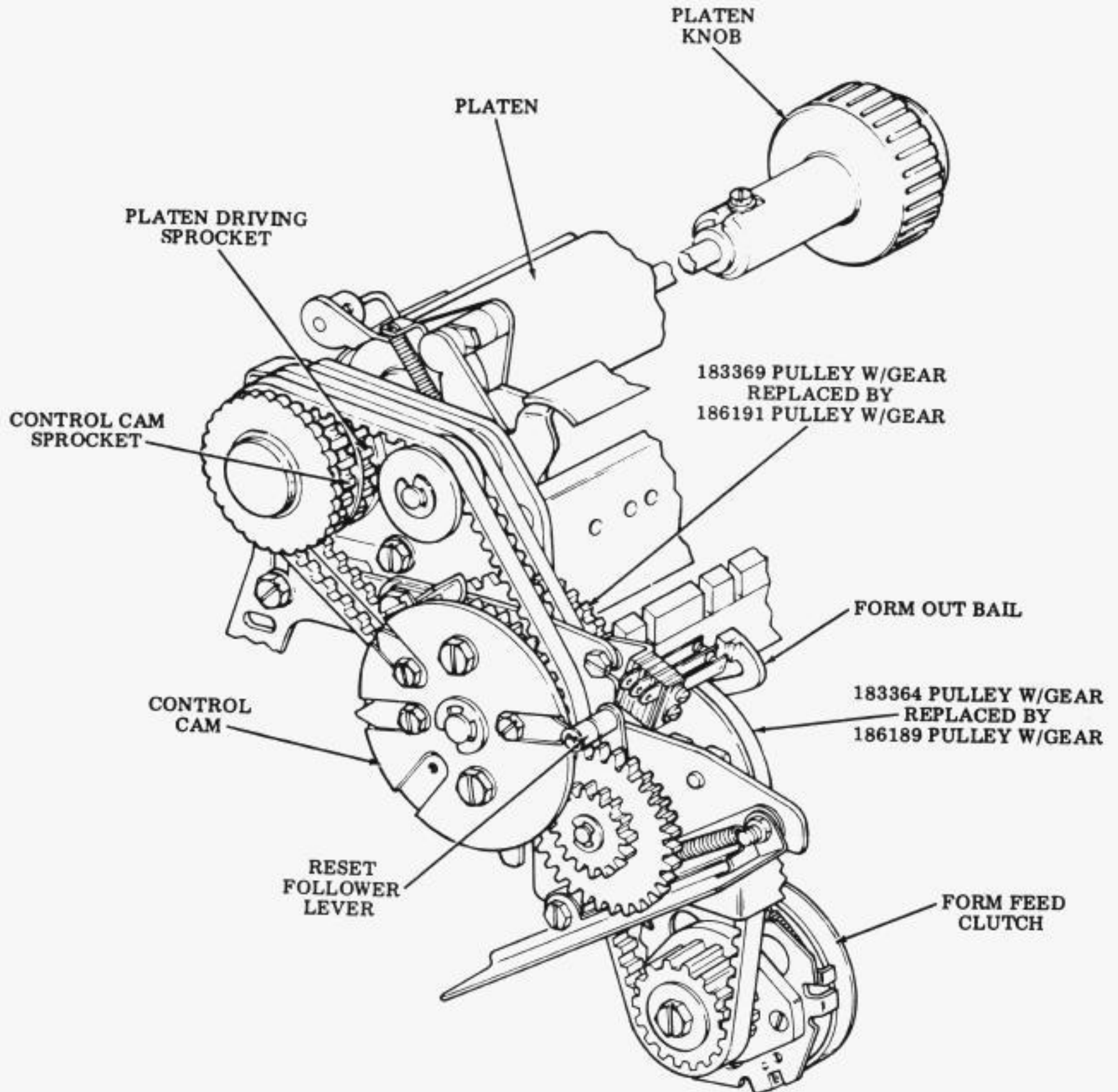

Figure 15 - Form Feed Mechanism

on the form feed mechanism of the sprocket feed typing unit. These part changes will convert the form feed rate from six line feeds per main shaft revolution to three line feeds per main shaft revolution. This will enable the unit to be

compatible in a systems network with other equipment having the slower form feed rate.

2.47 An explanation of the operation will be found in Section 574-172-100TC.



(Right Rear View)

Figure 16 - Platen Drive Mechanism

SECTION 574-160-105TC

Adjustments

2.48 Refer to Figure 17 for early design and late design line feed selection adjustments.

To Check
Place typing unit in stop condition.

Requirement
Single line feed
Min 0.145 -- Max 0.160 inch
between pawl and line feed lever.

Double line feed
Min 0.010 -- Max 0.090 inch
between pawl and line feed lever.

To Adjust
Early Design (FOA-13)
While holding rear part of line feed lever against downstop, loosen screw friction tight. Position line feed lever using pry points. Tighten screw.

Late Design (FOA-17)
With screw friction tight, position line feed lever using pry points. Tighten screw.

Related Adjustments
Affected By
Form Feed Belt Tension - S
Trip Lever Engagement -
Line Feed - S
Trip Lever Engagement -
Form Out - S
(See Section 574-172-700TC.)

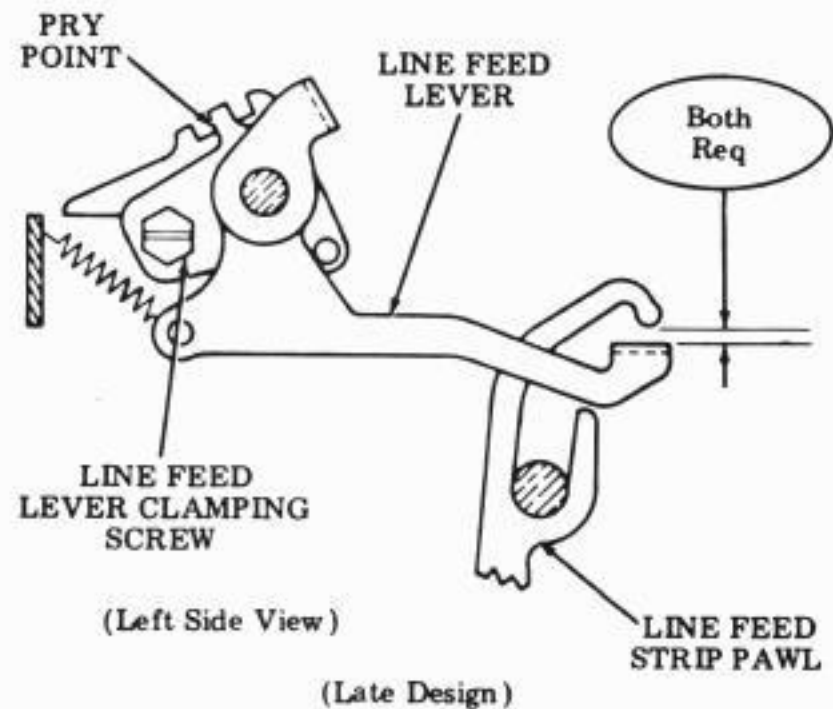
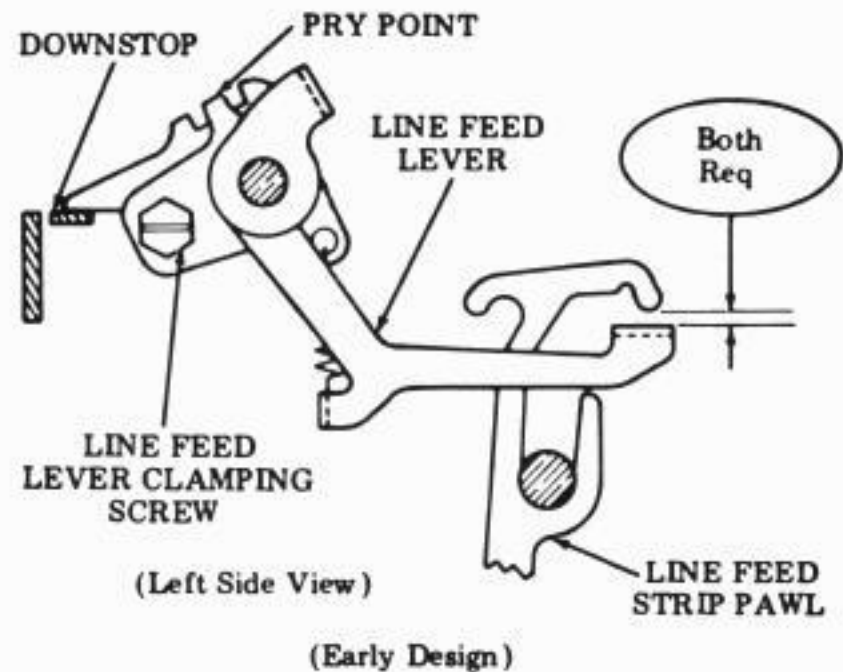

Figure 17 - Line Feed Selection Adjustment (FOA-13 or FOA-17)

Lubrication

2.49 Follow standard lubrication requirements as outlined in Section 574-172-701TC.

Disassembly and Reassembly

2.50 Since installation of this modification kit involves only a one-for-one part replacement (see Figures 15 and 16), follow the standard disassembly and reassembly procedures as outlined in Section 574-172-702TC.

J. 186226 Modification Kit - Provides Mobility for a Model 32 Set

Description and Operation

2.51 The modification kit consists of two feet, two brackets, four casters, and mounting hardware. The two feet, unlike the ones the cabinet is normally equipped with, are longer so as to extend beyond the rear of the cabinet to provide additional stability. When installed (see Figure 18), the modification kit provides a means of easily moving the set that is used in applica-

tions requiring different operating locations. A braking device is provided on the two front casters to prevent the set from moving while in operation.

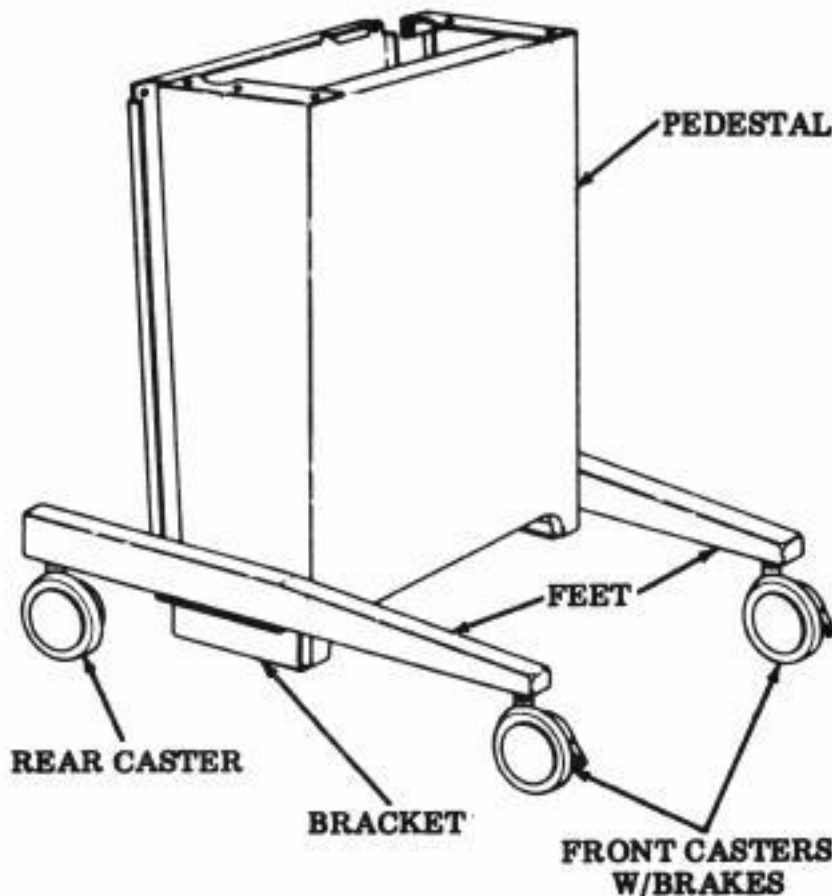

Figure 18 - Mobile Cabinet

2.52 No cabinet workover is required to install this modification kit.

Adjustments

2.53 See Figure 19 for foot and caster height adjustments.

Disassembly and Reassembly

2.54 Refer to Section 574-176-800TC for parts identification and proceed as follows:

- (a) Remove the 183244 back panel from the pedestal.
- (b) Unplug all cables within the pedestal.
- (c) Remove the hardware that secures the base with printer to the pedestal.
- (d) Remove the base and printer assembly from the pedestal.
- (e) Place the pedestal on its side or back (whichever is preferred) and remove each foot assembly by removing two 6035 screws, two 92146 nuts, two 2449 lock-washers, and four 2846 flat washers.

(1) Requirement
Foot should be against side of pedestal.

To Adjust
Loosen foot mounting screws. Position foot against side of pedestal. Tighten screws. Adjust both sides.

(2) Requirement
Min 3-5/16 inches
Max 3-9/16 inches
between floor and bottom side of foot.

To Adjust
Loosen caster nuts. Screw casters in or out to meet requirement. Tighten caster nuts.

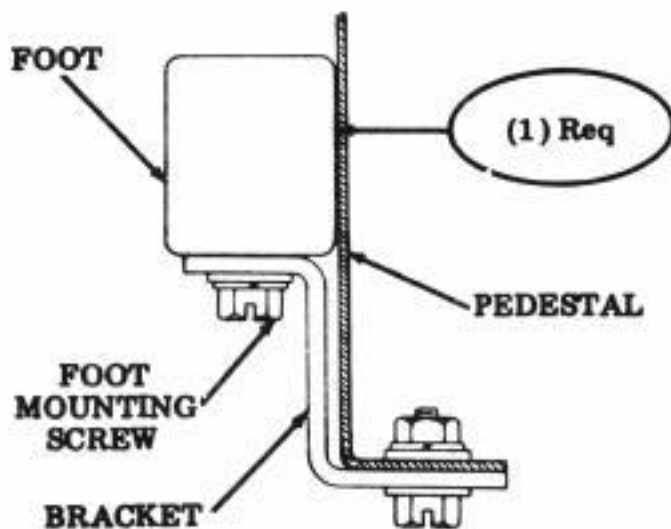

(Front View - Left Side)

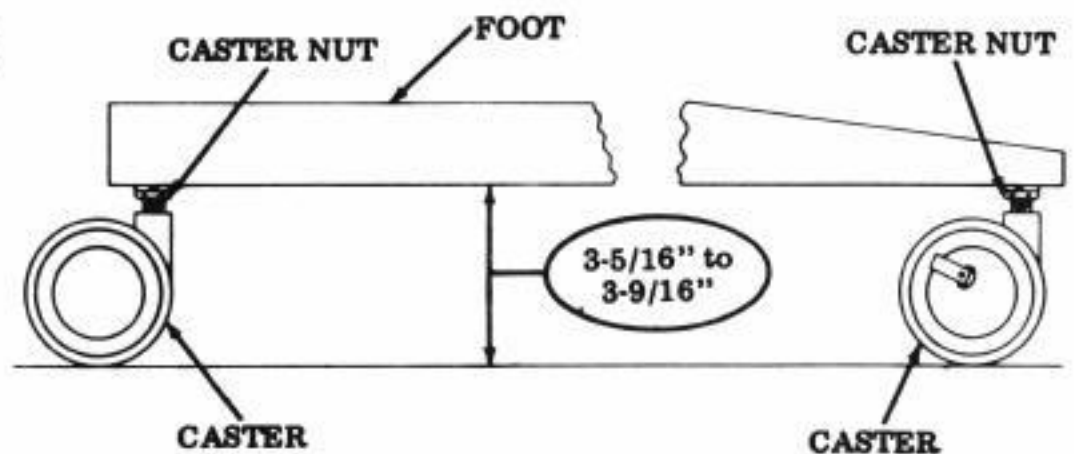

(Left Side View)

Figure 19 - Foot and Caster Adjustments

- (f) Remove the 186239 bracket from each foot assembly by removing two 6035 screws, two 2449 lockwashers, and two 2846 flat washers.
- (g) Remove the 186229 caster w/brake from the front of each 186238 foot.
- (h) Remove the 186227 caster from the rear of each 186238 foot.
- (i) To replace the foot assemblies, reverse the procedure used to remove them.

K. 186752 Modification Kit — Provides Locking of the Model 32 Keyboard

Description and Operation

2.55 The modification kit provides a locking mechanism, the function of which is to block the universal lever in its latched position,

thereby preventing the lever from tripping the distributor clutch in the typing unit.

2.56 The locking mechanism (see Figure 20) consists of a solenoid which when energized, pulls in its plunger causing a cam shaft assembly to rotate, imparting a counterclockwise movement to a trip cam. The camming surface of the trip cam engages the universal lever (which is in the latched-down position) driving the lever farther down and blocking it.

2.57 The lock mechanism operates only when the universal lever is latched (down position). If the set is turned off and the keyboard is tripped, keyboard lock will not occur until the universal lever is relatched.

Adjustment

2.58 See Figure 21 for locking mechanism adjustments.

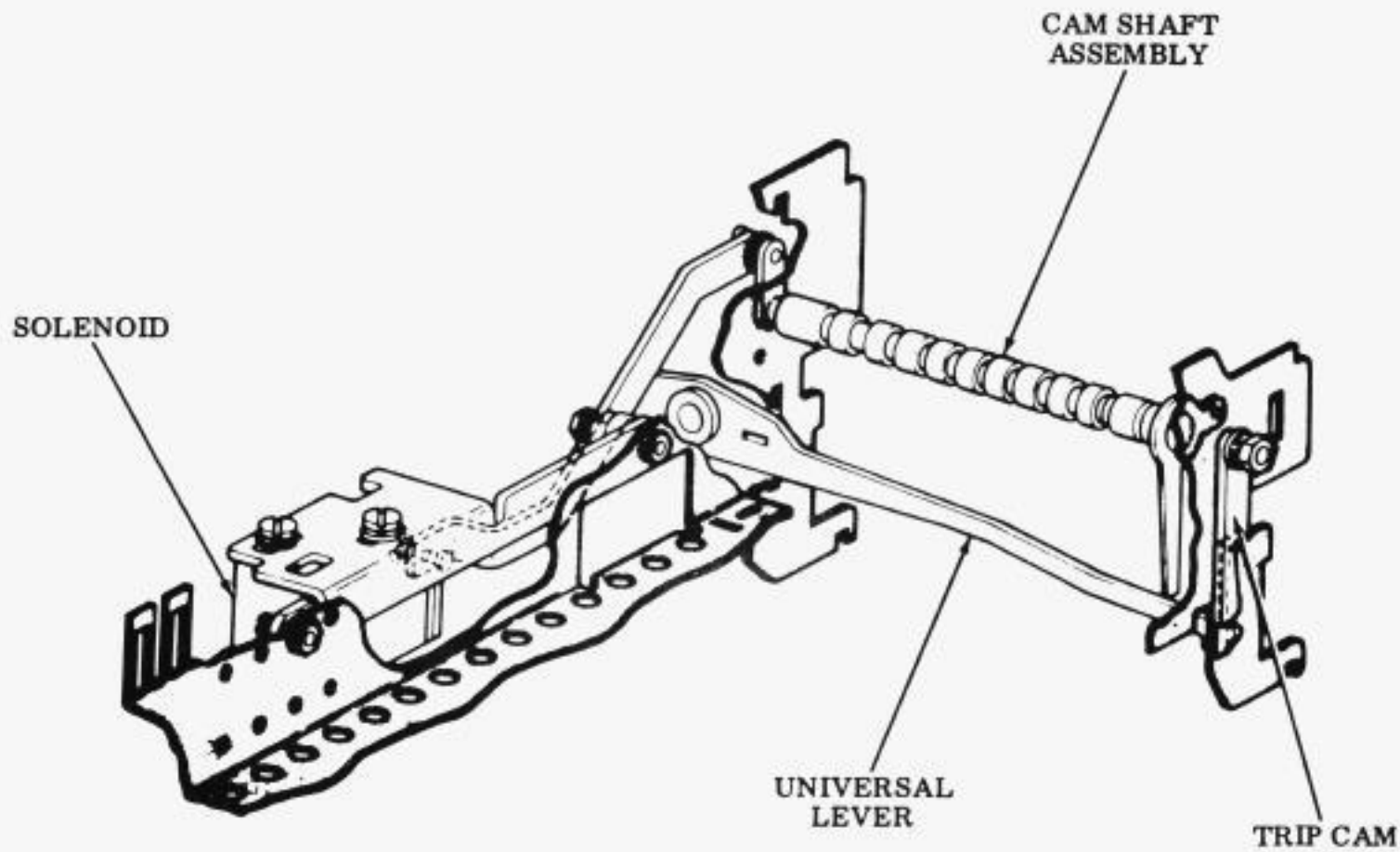

(Left Front View)

Figure 20 - Keyboard Locking Mechanism

LATCHLEVER

Note: The following adjustment must be made with the solenoid plunger completely seated in the coil (energized). To obtain this condition, bend the leaf spring tabs away from the solenoid.

Requirement

With solenoid energized
Min some -- Max 0.015 inch
between latchlever and trip arm.

To Adjust

Loosen solenoid mounting screws friction tight. Using pry points, position solenoid left or right to meet requirement. Tighten screws.

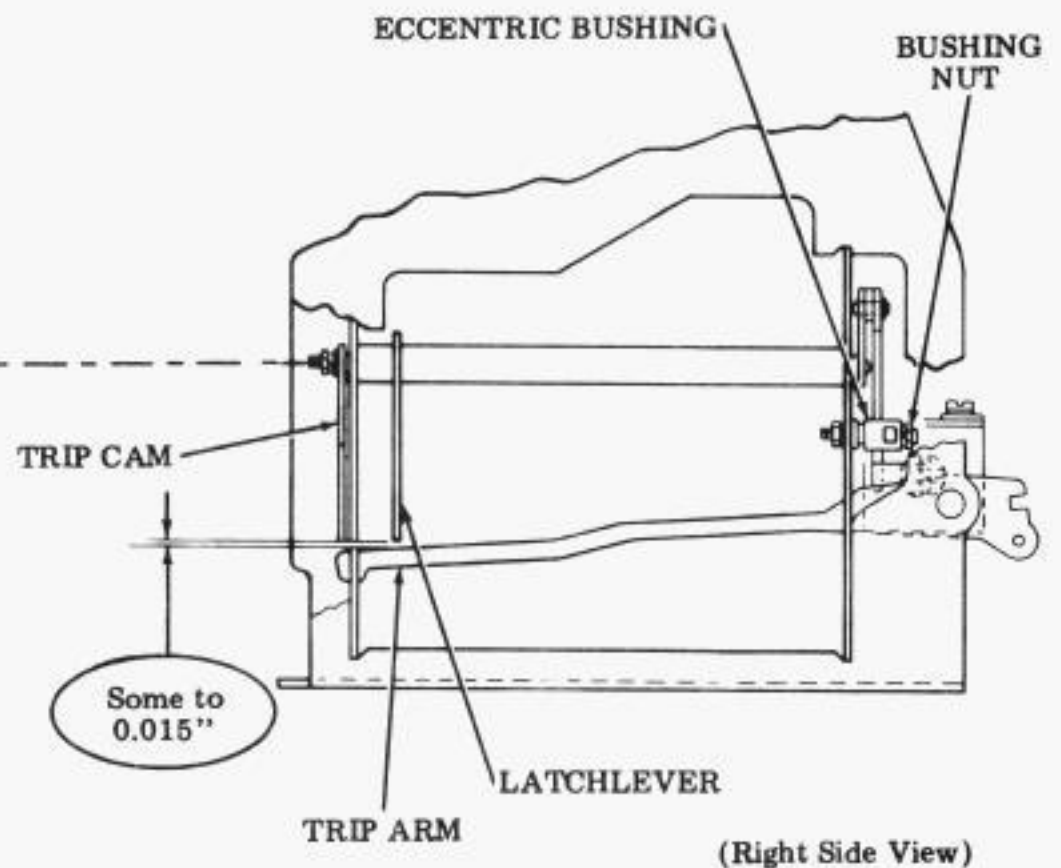
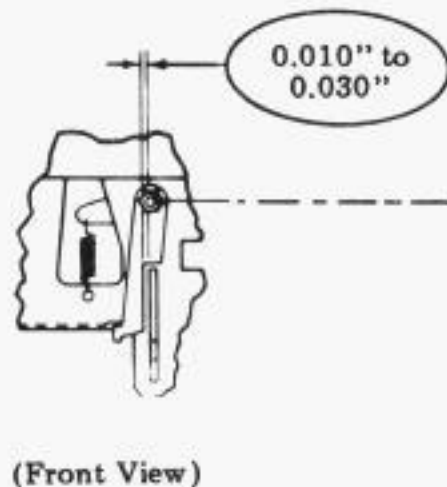
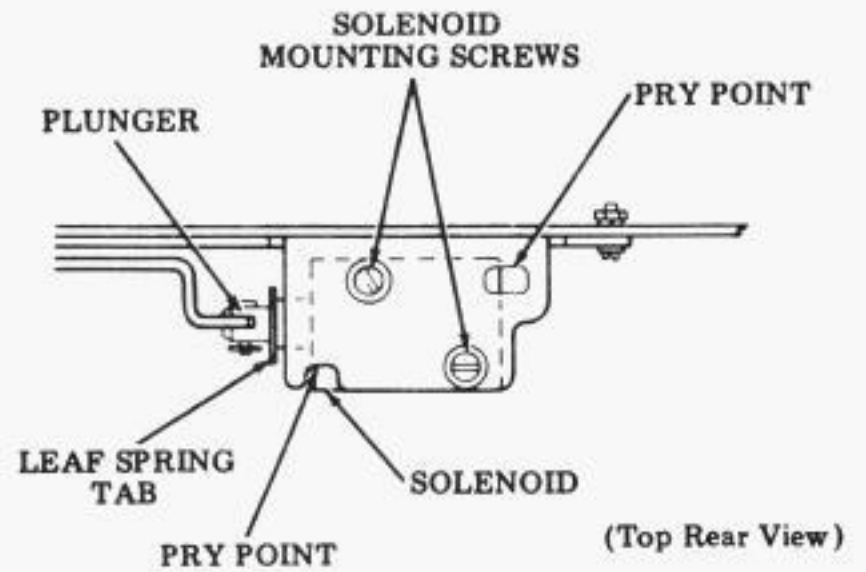
TRIP CAM**Requirement**

Min 0.010 inch -- Max 0.030 inch
between trip cam and slot in which trip arm
travels.

To Adjust

Loosen bushing nut friction tight. Rotate
eccentric bushing to meet requirement.
Tighten nut.

Figure 21 - Locking Mechanism Adjustments

SECTION 574-160-105TC

Lubrication

2.59 See Figure 22 for locking mechanism lubrication.

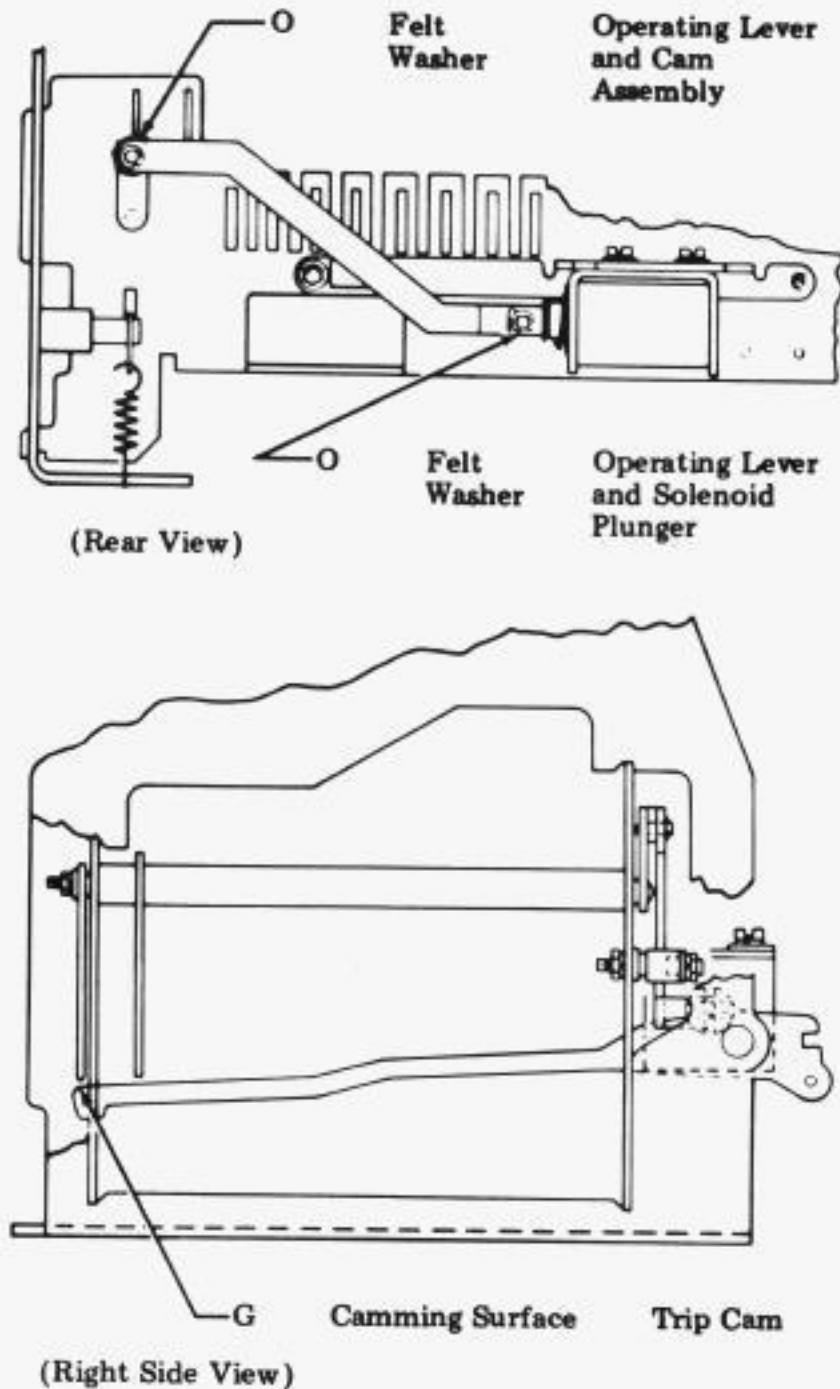

Figure 22 - Operating Lever and Trip Cam Lubrication

Disassembly and Reassembly

2.60 For parts identification, refer to Section 574-171-800TC and proceed as follows:

- (a) Remove the keyboard as outlined in Section 574-160-702TC covering removal and replacement of parts.
- (b) Remove the keyboard cover, keylevers, spacebar mechanism, codebars, keyboard contact mechanism, and T-lever shafts

by following disassembly procedures as outlined in Section 574-171-702TC covering disassembly and reassembly.

- (c) Remove the 119648 retaining ring securing the 186834 lever to the 186833 shaft w/lever.
- (d) Pull 186834 lever free from 186833 shaft post and remove 86079 felt washer.
- (e) Remove solenoid plunger, with 186834 lever attached, from solenoid.
- (f) Remove 303037 spring from solenoid plunger.
- (g) Disassemble the 186834 lever from solenoid plunger by removing the 119648 retaining ring, 321895 pin and 86079 felt washer.
- (h) Remove 186832 eccentric bushing by removing 151880 nut, 93984 lockwasher, and 104807 flat washer from stud on 186830 bracket.
- (i) Remove 186874 trip cam by removing 3599 nut, 130664 lockwasher, and 125011 flat washer.
- (j) Remove 186833 shaft w/lever from within 186700 shaft.
- (k) Remove 186700 shaft by spreading the sides of the keyboard frame.
- (l) Remove the 185802 solenoid by removing two 1263 screws, 2191 lockwashers, and 90790 flat washers.
- (m) Remove 186830 bracket by removing the 5740 screw, two 93117 lockwashers, two 112627 nuts, and 71073 flat washer.
- (n) To replace the locking mechanism reverse the procedures used to remove it.

L. 186776 Modification Kit — Provides a Handle for Model 32 Typing Unit

Description

2.61 The modification kit provides a handle (Figure 23) which when assembled to the printer base casting, assists in lifting the

printer for purposes of installation or removal. The handle, once installed, can remain in place.

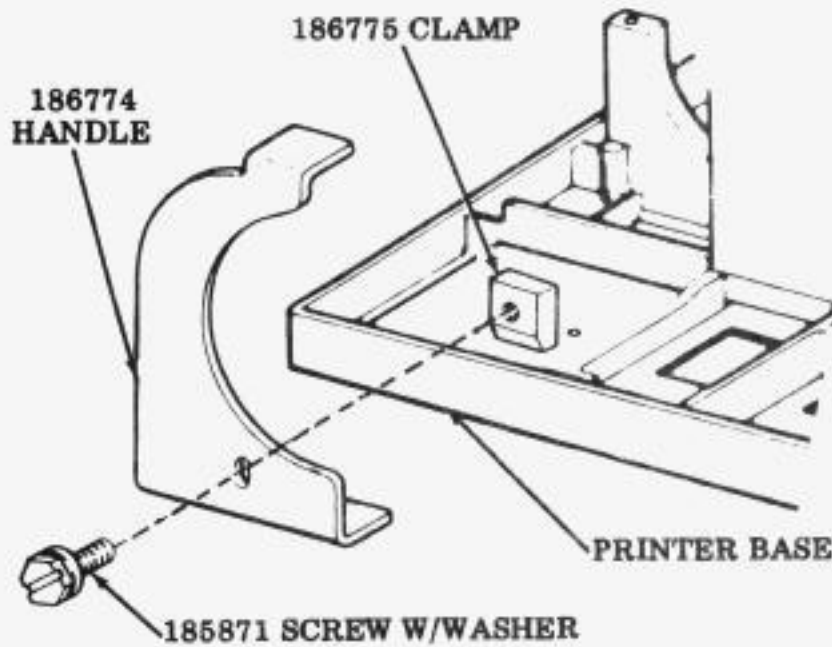

Figure 23 - Typing Unit Handle

Disassembly and Reassembly

2.62 To remove or to replace the handle, perform the following steps:

- (a) Remove all power from the unit.
- (b) Remove cover as outlined in Section 574-160-702TC covering removal and replacement of components.
- (c) Loosen the 186775 clamp (see Figure 23) and remove the 186774 handle.
- (d) Disassemble the 186775 clamp from the 186774 handle by removing the 185871 screw w/washer.
- (e) To replace the handle reverse the procedure used to remove it.

M. 194822 Directory Holder for Model 32 KSR and ASR Cabinets

Description

2.63 The 194822 directory holder provides KSR and ASR cabinets with a facility for conveniently storing directories and similar materials.

2.64 The directory holder is mounted to the cabinet (see Figure 24) by means of an adhesive tape fixed to the back of the holder. The

protective backing is simply removed from the tape and the holder is pressed into place. Refer to Specification 50602S.

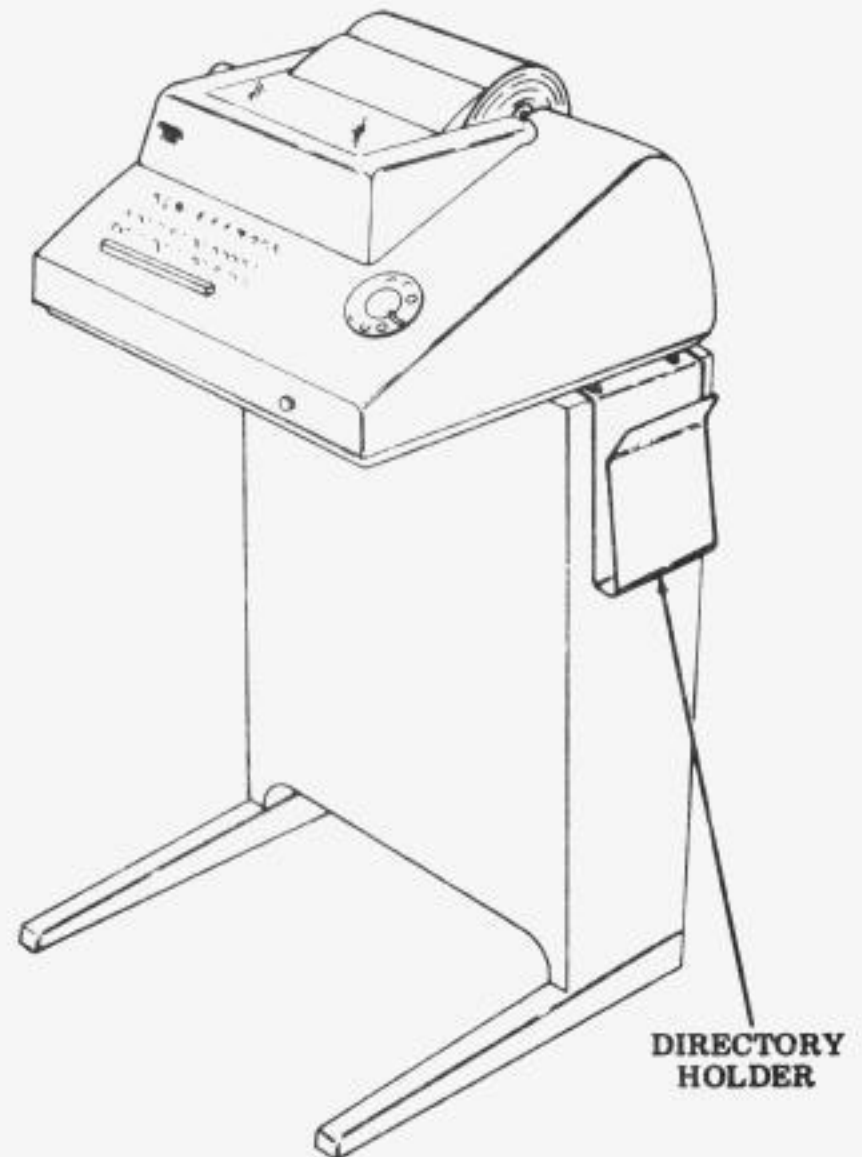

Figure 24 - Cabinet With Directory Holder

N. 333521 Set of Parts — Provides AC Motor and Governor Assembly to be Used in Driving Model 32 Apparatus in Locations Where Regulated 50/60 Hertz Frequency Alternating Current is not Available

Description and Operation

2.65 Unregulated frequency causes speed variations which result in printing errors when synchronous motors are used. This set of parts consists of an ac series motor, a governor assembly, and a brush holder assembly. A bidirectional switch is wired in series with the series motor armature and two field windings, and is controlled by contacts located in the governor.

2.66 Within a predetermined speed, a governor contact spring holds the governor contacts closed (see Figure 25). When

SECTION 574-160-105TC

the motor shaft exceeds the predetermined speed, the centrifugal force exerted on the governor contact arm briefly overcomes the tension of the governor contact spring causing the governor contacts to open. The trigger is removed from the gate of the bidirectional switch located in the brush holder assembly causing the switch to go into the blocking or nonconducting state, thereby removing current to the motor causing it to slow down. The motor slows to a point where the diminished centrifugal force allows the governor contacts to close, once again restoring current to the motor. The tension on the contact spring is adjusted by means of an adjusting screw to maintain the motor speed at 3600 rpm.

Adjustments

2.67 For adjustment information, refer to Section 570-220-700TC.

Lubrication

2.68 For lubrication requirements, refer to Section 570-220-701TC.

Disassembly and Reassembly

2.69 For disassembly and reassembly instructions, refer to Section 570-220-702TC.

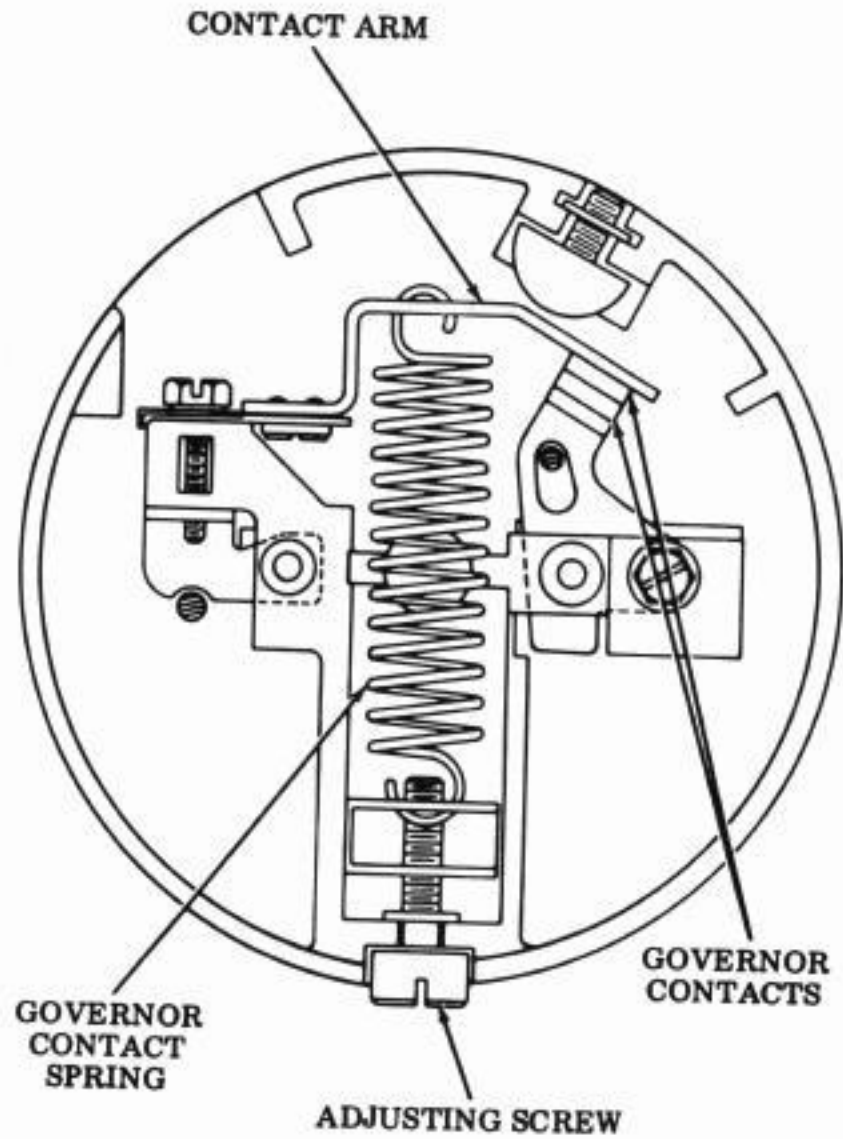

Figure 25 - Motor Governor