

TECHNICAL MANUAL
32 AND 33
TELETYPEWRITER SETS
KEYBOARD SEND-RECEIVE (KSR)
RECEIVE-ONLY (RO)
AUTOMATIC SEND-RECEIVE (ASR)

1. GENERAL

- 1.001 This addendum supplements existing adjustments in Bulletin 273B, Volume 2, Change 5, and applies only to 33TN and 33TX ASR sets.
- 1.002 Adjustments on the following pages augment sections in Bulletin 273B, Volume 2, as follows:

574-121-700	Keyboard	Part 3
574-122-700	Typing Unit	Part 2
574-124-700	Tape Reader	Part 4

Precede the CONTACT WIRES adjustment in Section 574-121-700 with the adjustments found in Paragraphs 3.001 and 3.002 respectively. All of the other adjustment information should be performed in the sequence presented and can follow the existing adjustment information found in the applicable sections listed above.

Note: Disregard the UNIVERSAL LINK and DISTRIBUTOR TRIP LINKAGE adjustments in Section 574-121-700 and the TRIP LEVER ENGAGEMENT adjustment in Section 574-122-700. They are not applicable.

- 1.003 Special lubrication instructions for 33TN and 33TX ASR sets are given in Part 6. All other lubrication instructions can be found in Bulletin 273B, Volume 1.

2. PRINTER ADJUSTMENTS

PRINTER "ON" TRIP ARMATURE ADJUSTMENT (See Figure 1)

- 2.001 Requirement: With the codebar moved to the right and latched, there shall be 0.010" to 0.020" clearance between the edge of the no. 4 function lever and the edge of the codebar tine.
- 2.002 To Adjust: Loosen the printer "OFF" solenoid mounting screws and position solenoid to the right to allow codebar unrestricted motion. Loosen armature clamp screw and adjust length of armature by means of pry points.

PRINTER "OFF" SOLENOID BRACKET ADJUSTMENT (See Figure 2)

2.003 Requirement: With the solenoid held electrically energized or with the plunger held mechanically seated, there shall be 0.006" to 0.012" clearance between the end of the trip armature and the latch surface.

2.004 To Adjust: Loosen the solenoid mounting screws and position solenoid body by means of pry points.

PRINTER "ON" TRIP MAGNET OVERTRAVEL ADJUSTMENT (See Figure 3)

2.005 Requirement: With the armature held against the core, there shall be 0.010" to 0.015" clearance between the armature and latch.

2.006 To Adjust: Loosen clamp nut and adjust overtravel by turning adjusting screw.

3. KEYBOARD ADJUSTMENTS

KEYBOARD DRIVE HUB ADJUSTMENT (See Figure 4)

3.001 Requirement: With the play taken up to the right, there shall be 0.060" to 0.070" clearance between the adjusting plate and keyboard reset lever.

Note: There is enough play that reset lever will touch adjusting screw.

3.002 To Adjust: Loosen setscrew and position hub.

KEYBOARD RESET LEVER ADJUSTMENT (See Figure 4)

3.003 Requirement: With the reset solenoid energized, there shall be 0.010" to 0.040" clearance between the keyboard reset lever and the latchlever.

3.004 To Adjust: Loosen clamp adjusting screw and position by pry points.

KEYBOARD CLEAR SWITCH ADJUSTMENT (See Figure 4)

3.005 Requirement: The switch actuator shall be centered in engagement with the keylever (by eye) and there shall be 0.025" to 0.040" clearance between the keylever and actuator in the unoperated condition.

3.006 To Adjust: Loosen bracket mounting screws to meet centering adjustment. Loosen switch mounting screws and position actuator to meet requirement.

KEYBOARD TIMING CONTACT MAGNET ADJUSTMENT (See Figure 4)

3.007 Requirement: There shall be 0.020" to 0.040" clearance between magnet face and reed switch assembly.

3.008 To Adjust: Bend extension lever at form to meet requirement.

KEYBOARD TIMING CONTACT ADJUSTMENT (See Figure 4)

3.009 Requirement: (Preliminary) Position reed switch assembly so that rear edge of assembly is approximately flush with rear edge of bracket.

3.010 Requirement: (Final) With the keyboard reset lever in the latched position, the contact shall be closed; with the keyboard reset lever tripped, the contact shall be open.

3.011 To Adjust: Loosen clamp screw and position switch assembly to meet requirement.

4. READER ADJUSTMENTS

TIMING CONTACT ADJUSTMENTS (See Figure 5)

4.001 Requirement: (Preliminary) Position both switches so that they are in the center of their adjustment slots.

4.002 Requirement: (Final) With the sensing pins fully down, the reset switch (front) shall be closed and the busy switch (rear) shall be open. With the sensing pins fully up in the energized position, the switches shall transfer.

4.003 To Adjust: Loosen adjusting screws and move switches up or down to meet requirement.

5. SPRING TENSIONS

PRINTER "ON" TRIP ARMATURE SPRING TENSION (See Figure 6)

5.001 With the armature de-energized and holding the suppression codebar to the right, it shall take 2 to 3 oz to start the armature moving.

LATCH SPRING TENSION (See Figure 7)

5.002 With the latch disengaged, it shall take 2 to 3 oz to start the codebar moving.

RESET LEVER SPRING TENSION (See Figure 4)

- 5.003 With the reset lever latched, it shall take 9-1/2 to 10-1/2 oz to start the reset lever moving.

TRIP MAGNET ARMATURE SPRING TENSION (See Figure 8)

- 5.004 With the cam roller on the high part of the trip lever cam and the armature unattracted, it shall take 2 to 3 oz to start the armature moving.

6. LUBRICATION

- 6.001 Oil all pivots and slots associated with the keyboard reset lever. Do not oil solenoid.
- 6.002 Should the rotary solenoid require lubrication, use only Beacon 325 or ANG 25 grease or equivalent.
- 6.003 The solenoid should be disassembled with care and cleaned prior to relubrication. There are small loose parts internally and only experienced personnel should perform this task.

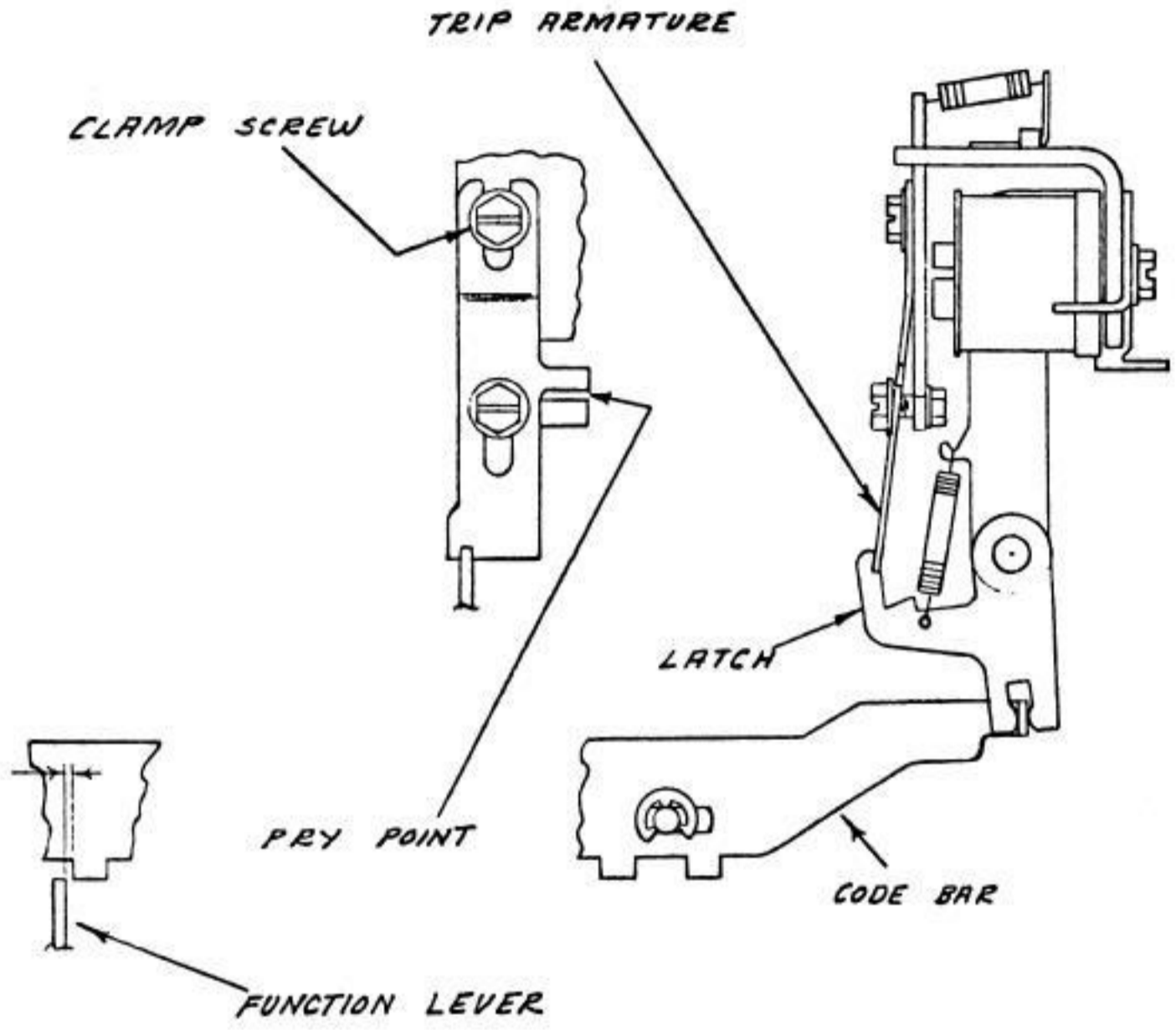

TRIP ARMATURE ADJUSTMENT

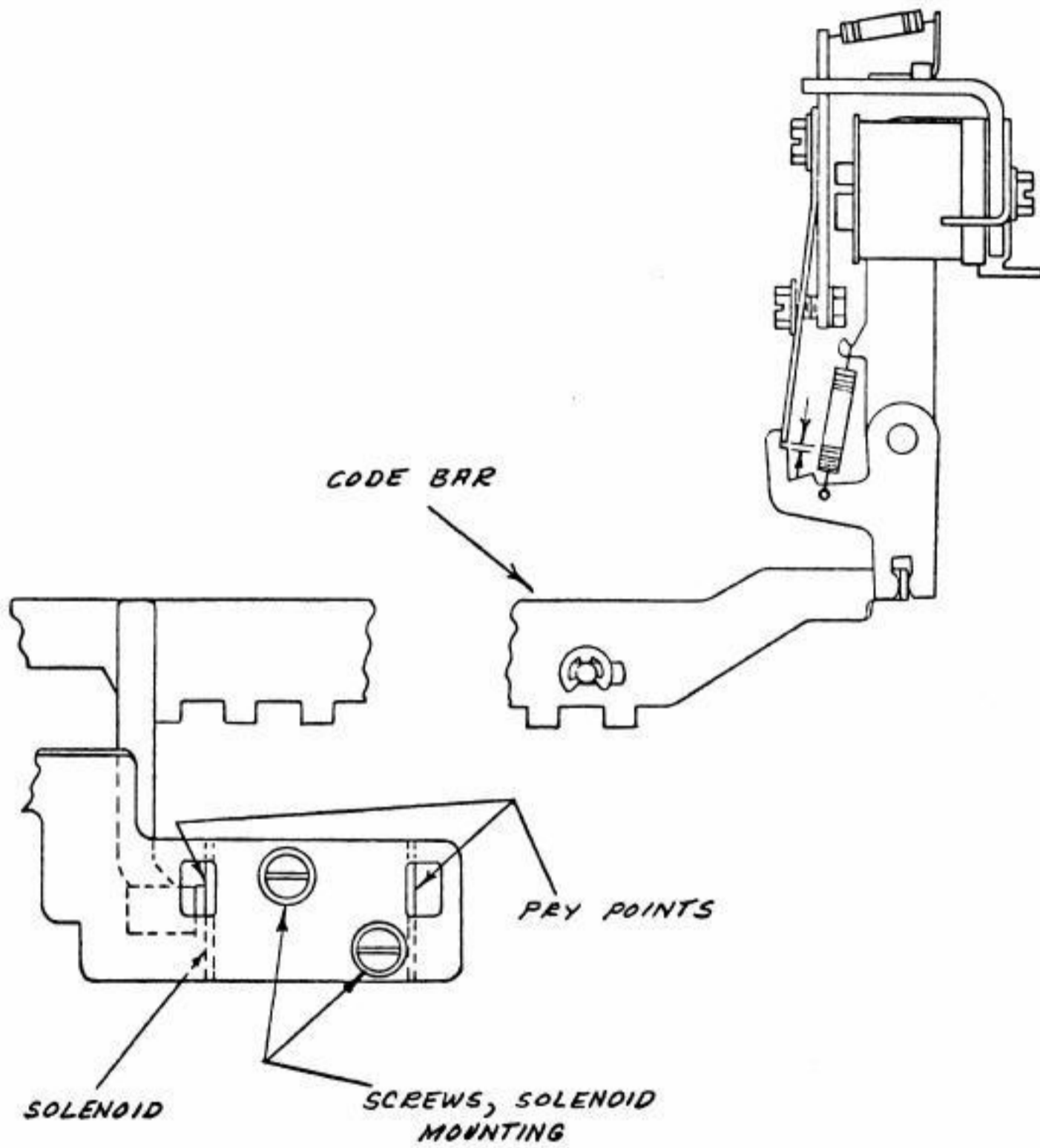

SOLENOID BRACKET ADJUSTMENT

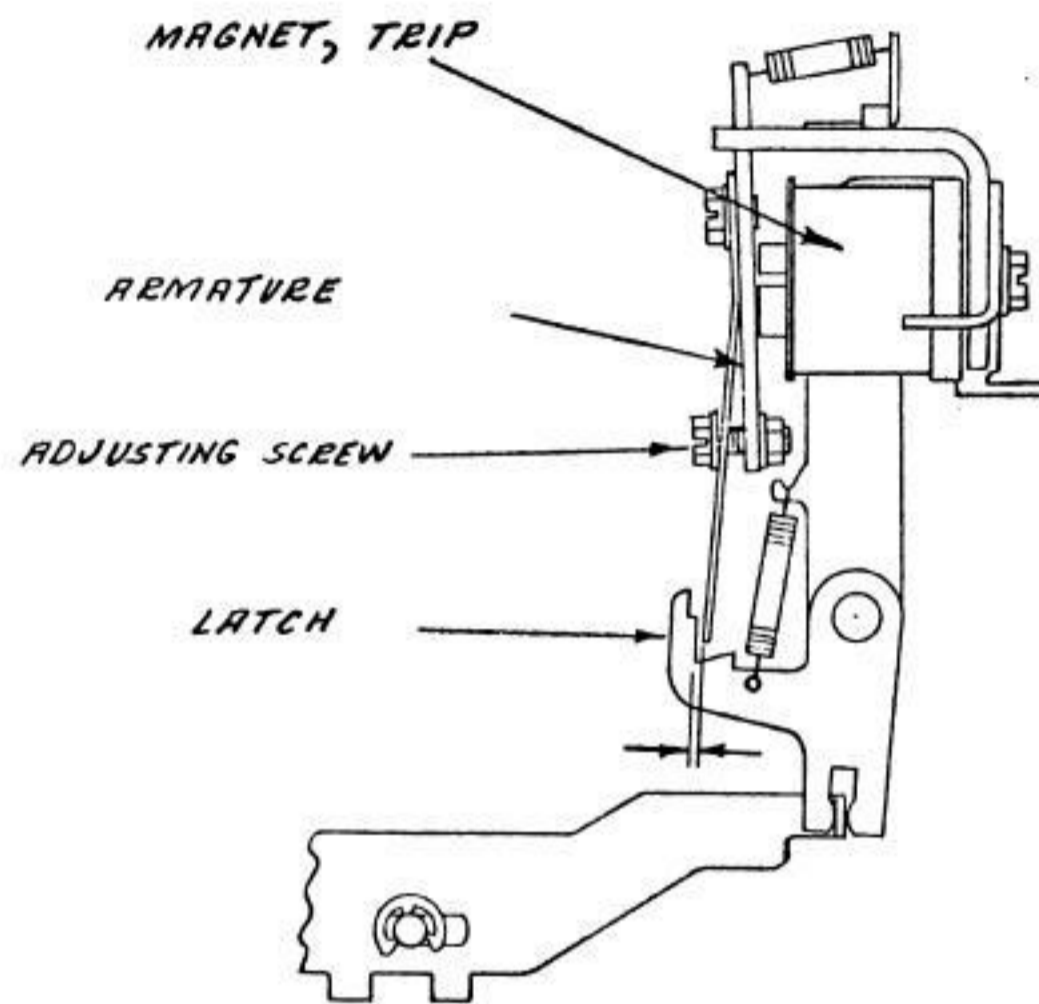

TRIP MAGNET OVERTRAVEL ADJUSTMENT

Figure No. 4

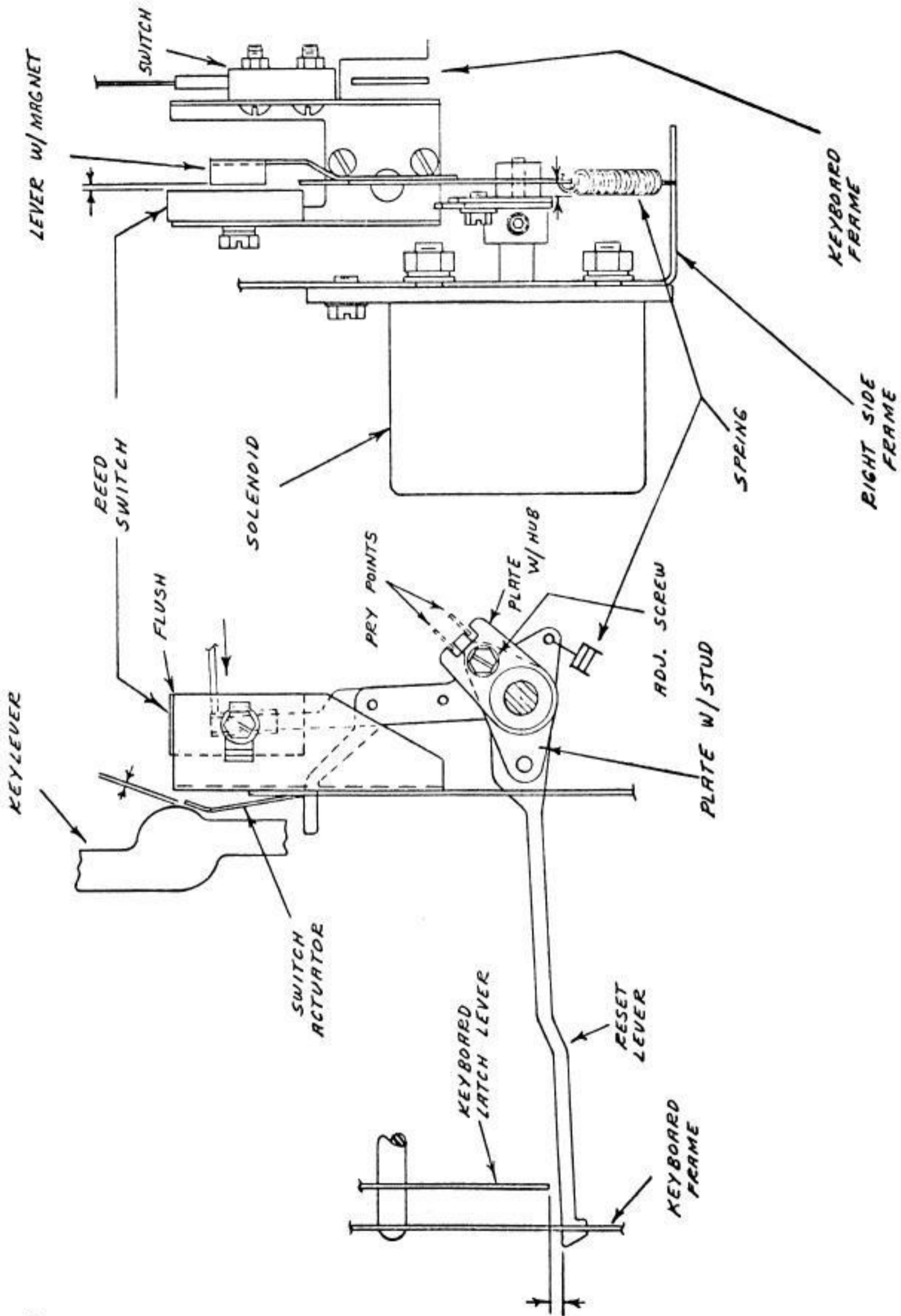

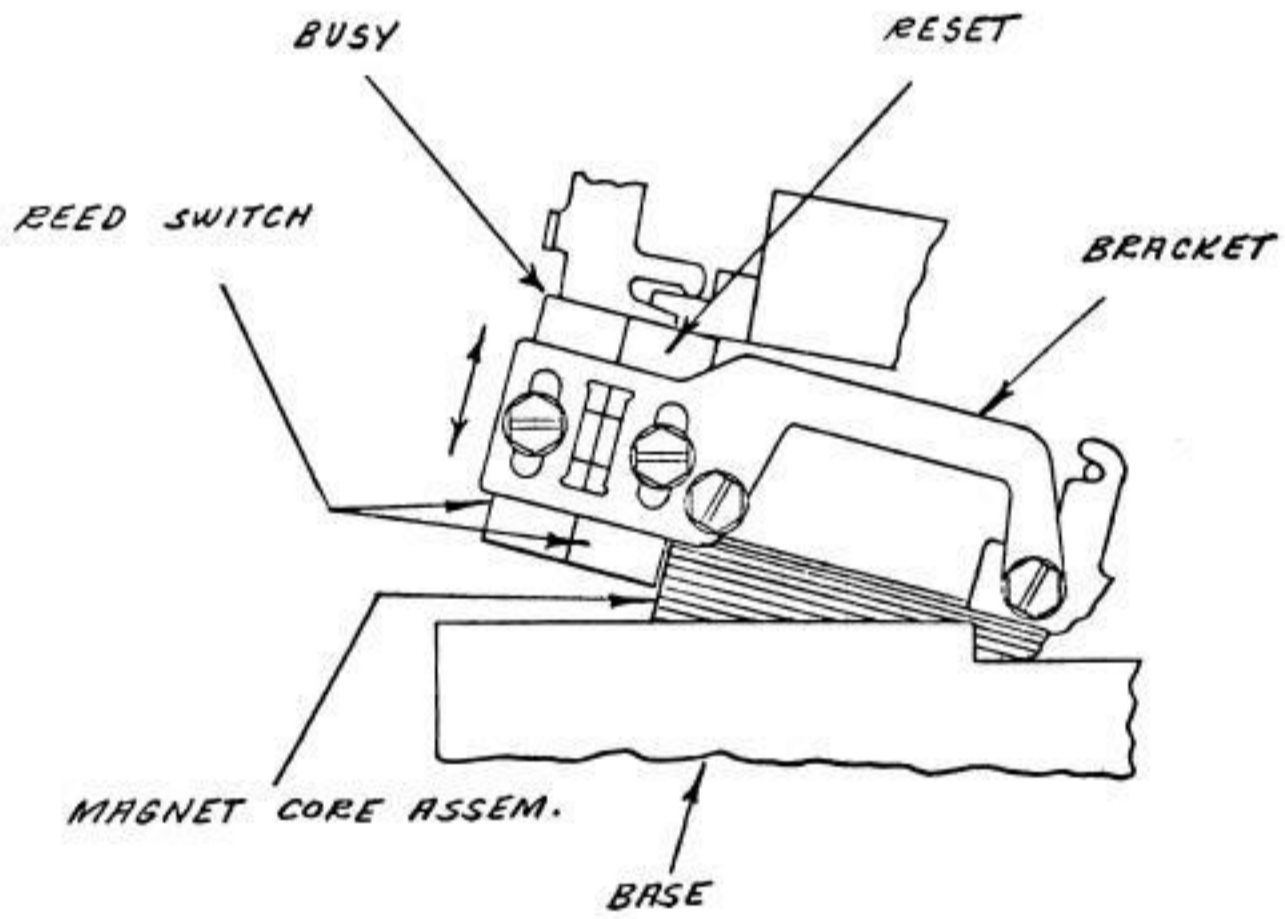

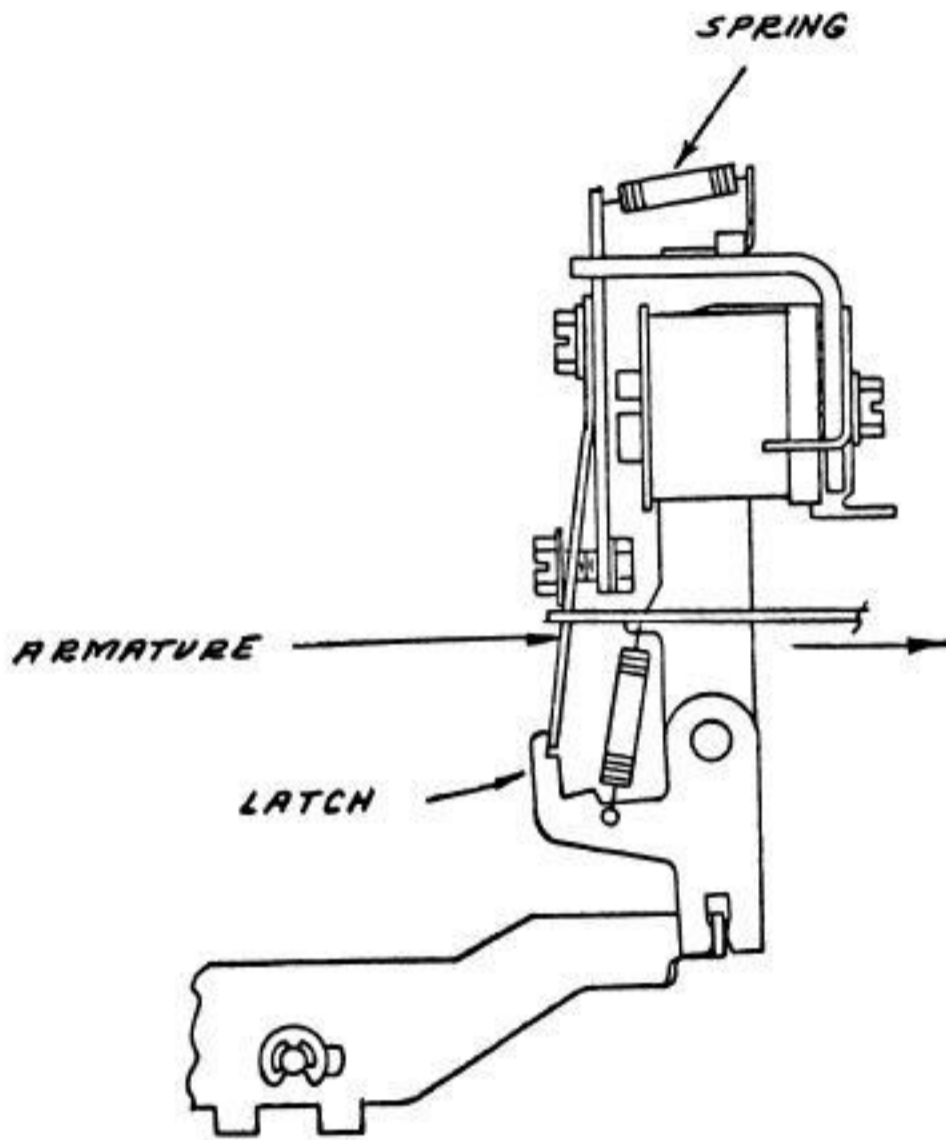

ARMATURE SPRING TENSION

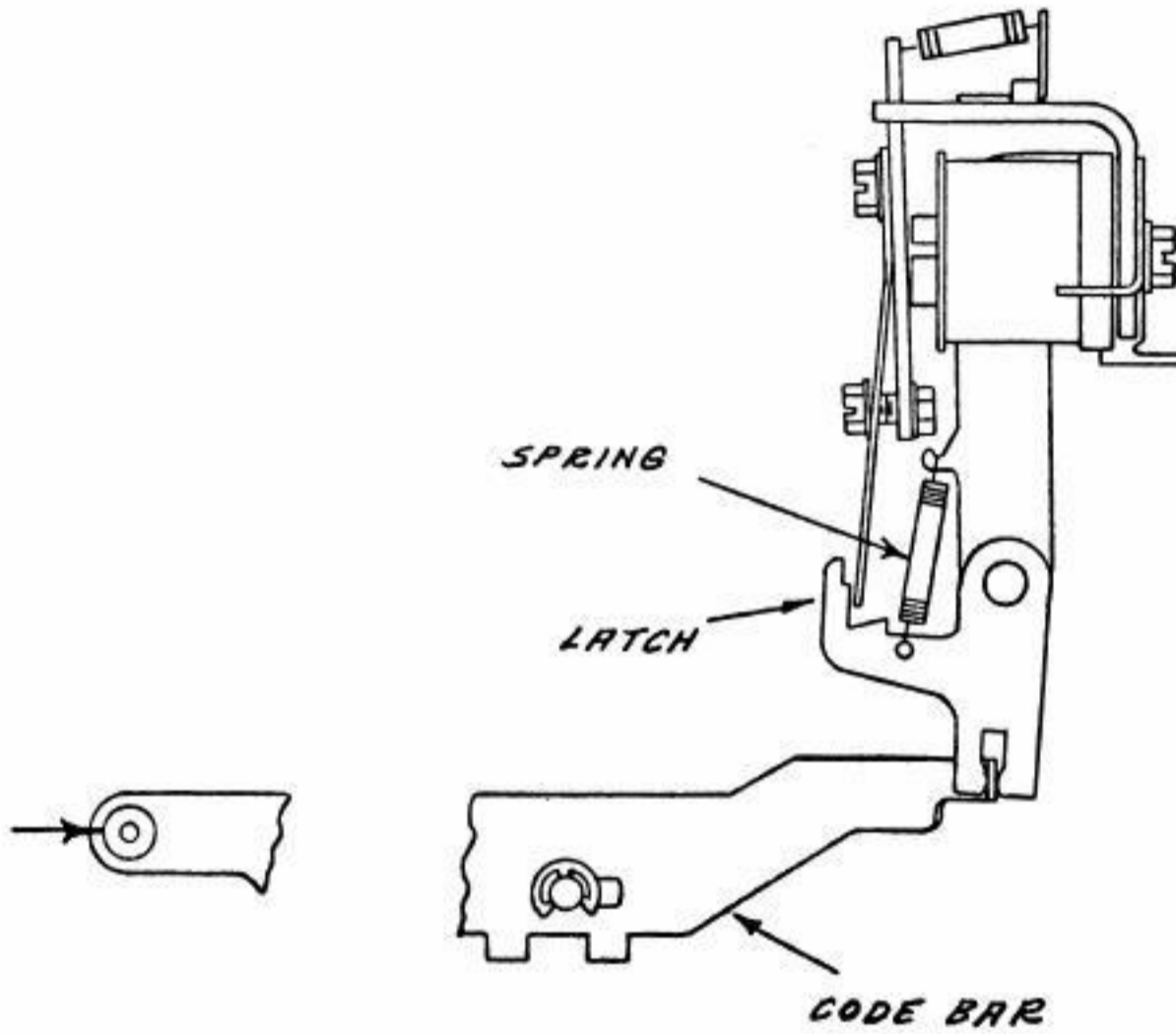

LATCH SPRING TENSION

Figure No. 8

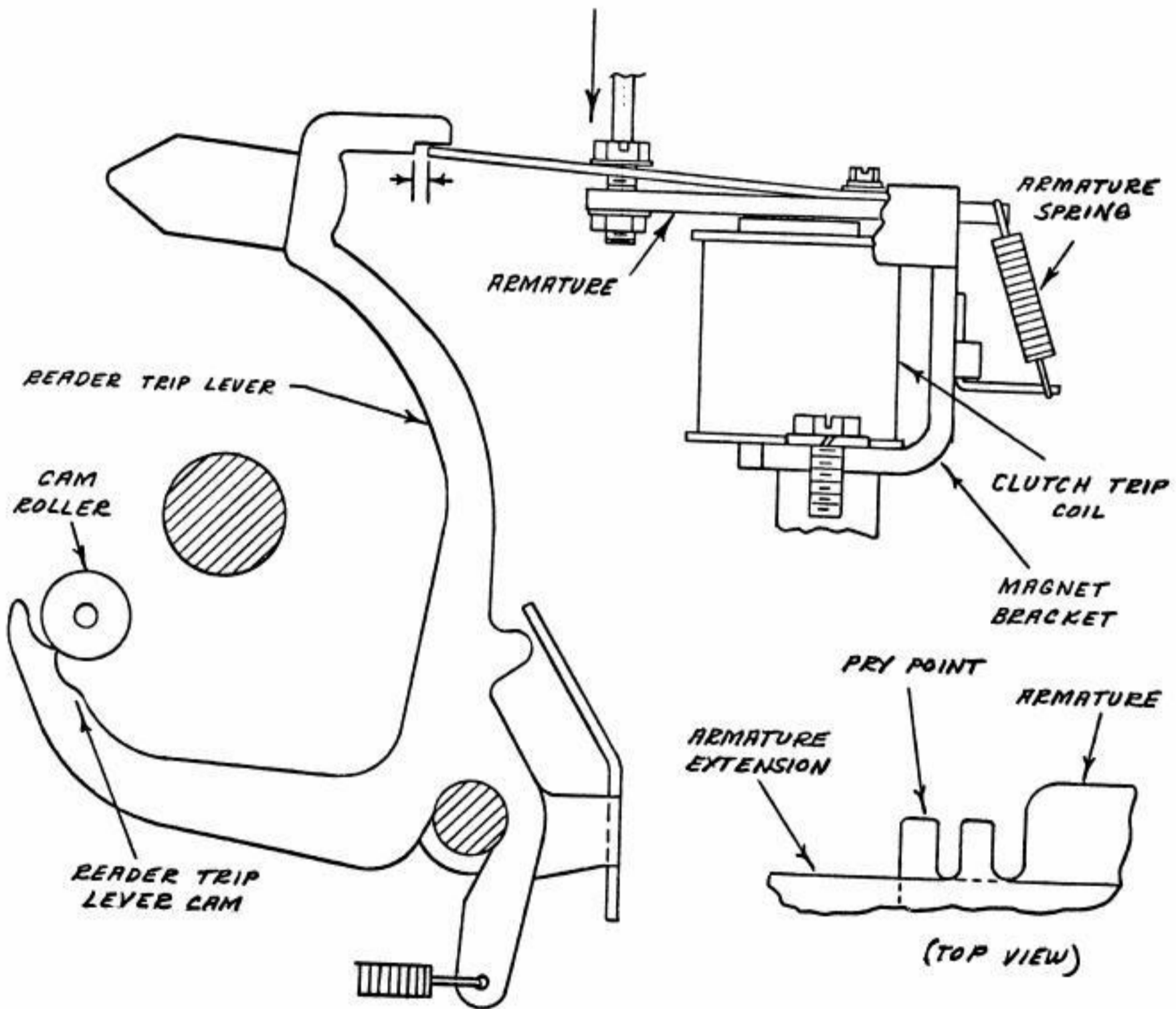

TRIP MAGNET ARMATURE SPRING
(CLUTCH TRIP)

BULLETIN 273B
VOL 2

TECHNICAL MANUAL
32 AND 33
TELETYPEWRITER SETS
KEYBOARD SEND-RECEIVE (KSR)
RECEIVE-ONLY (RO)
AUTOMATIC SEND-RECEIVE (ASR)

CONTENTS

ADJUSTMENTS



TELETYPE[®]
CORPORATION

5555 TOUHY AVENUE, SKOKIE, ILLINOIS

BULLETIN 273B
VOL 2

TECHNICAL MANUAL
32 AND 33
TELETYPEWRITER SETS
KEYBOARD SEND-RECEIVE (KSR)
RECEIVE-ONLY (RO)
AUTOMATIC SEND-RECEIVE (ASR)

CONTENTS
ADJUSTMENTS



TELETYPE[®]
CORPORATION
5555 TOUHY AVENUE, SKOKIE, ILLINOIS

VOLUME 2

INTRODUCTION

Bulletin 273B is a technical manual that provides general and specific information about the 32 and 33 Keyboard Send-Receive (KSR), Receive-Only (RO), and Automatic Send-Receive (ASR) Teletypewriter Sets and their component units. It consists of two volumes.

Volume 1 contains a description of the 32 and 33 Teletypewriter Sets and gives installation instructions. Also included in Volume 1 is information on the disassembly and reassembly, lubrication, and principles of operation of the component units of the Teletypewriter Sets. Volume 2 includes adjustment information on all component units of 32 and 33 Teletypewriter Sets.

Each volume is made up of a group of appropriate independent sections. Each independent section is complete within itself—it is separately identified by a title and section number, and the pages are numbered consecutively.

Each individual section is identified by a 9-digit section number which appears at the top of each page of a section. The section number appears on the left corner of left-hand pages and on the right corner of right-hand pages. In addition, the section number on the first page contains the suffix TC which identifies it as a Teletype Corporation section. All sections are placed in the technical manual in ascending numerical order.

To locate specific information, refer to the table of contents on the following page. In the first column, under "Equipment," find the name of the component unit or set in question. Move across the page to the second column and locate the title being sought. The applicable 9-digit section number can then be found in the third column. Turn to Page 1 of the applicable section, and the contents of that section will be found.

VOLUME 2
TABLE OF CONTENTS

FILING INSTRUCTIONS

1. The following filing instructions apply to changes sent to the field.
2. Asterisks (*) in the table of contents indicate changes.
3. When the issue of a section changes, replace the old issue with the attached new one.
4. In the case of addendums, turn to the affected section and follow the instructions on the first page of the attached addendum.
5. Replace the old table of contents with this new one.

Note: Adjustments for the cover are included in Section 574-126-100.
This section is found in Volume 1 of this bulletin.

<u>Equipment</u>	<u>Title</u>	<u>Section</u>	<u>Issue</u>
Keyboard	Adjustments	574-121-700	1
Typing Unit	Adjustments	574-122-700	2
Tape Reader	Adjustments	574-124-700	1, Add 1
Tape Punch	Adjustments	574-125-700	2, Add 1*