

"INKTRONIC[®]" PAGE PRINTER SET (RO)

INSTALLATION

CONTENTS	PAGE	1. GENERAL
1. GENERAL	1	1.01 This section provides the installation procedure for the INKTRONIC Receive-Only Page Printer Set (Figures 1 and 2). It is being reissued to place the section in standard format and to include recent engineering changes. Since this is a general revision, marginal arrows used to indicate changes and additions are omitted.
2. INSTALLATION PROCEDURE	1	1.02 Testing and checkout information is contained in Section 592-820-300TC.
UNPACKING	1	
VARIABLE FEATURES	4	
DATA SET INSTALLATION OR "TELESPEED*" CONNECTION FOR SERIAL INTERFACE (DAIF1)	4	2. INSTALLATION PROCEDURE
A. Installing a 202C Data Set	9	UNPACKING
B. Installing a 202D Data Set	9	2.01 Remove the set from its carton as follows:
C. Connection to a TELESPEED Type 2 Sender Only	11	(1) Remove the cover from the box.
D. Connection to a TELESPEED Type 2 Receiver Only	11	(2) Remove the nails fastening the side and back panels to the base skid.
E. Connection to Both a TELESPEED Type 2 Sender and Receiver	12	(3) Carefully remove the box assembly. Support the cartons containing the panels.
DATA SET INSTALLATION OR "TELESPEED" CONNECTION FOR PARALLEL INTERFACE (DAIF2)	13	(4) Remove all tape and other packing material from the set and panels.
A. Installing a 402D Data Set	13	(5) Carefully remove the set from the base skid.
B. Installing an 804A Data Auxiliary Set	13	2.02 Remove the cover assembly from the top deck of the set by pressing in on the latch buttons on the sides of the cover and lifting the cover upward so it separates from its base and front panel. Set the cover aside and remove the three large screws that secure the paper transport assembly to the cover base. These three screws are located in the following positions:
C. Connection to a TELESPEED Type 5 Sender Only	13	(1) On the left side of the transport, just to the rear of the front "leg" of the transport frame.
D. Connection to a TELESPEED Type 5 Receiver Only	14	(2) On the right side of the transport, just to the rear of the front "leg" of the transport frame.
E. Connection to Both a TELESPEED Type 5 Sender and Receiver	14	
PANEL AND DOOR INSTALLATION	15	
PAPER INSTALLATION	18	
INK SUPPLY	19	
ELECTRICAL CONNECTIONS	20	

*Trademark of Teletype Corporation

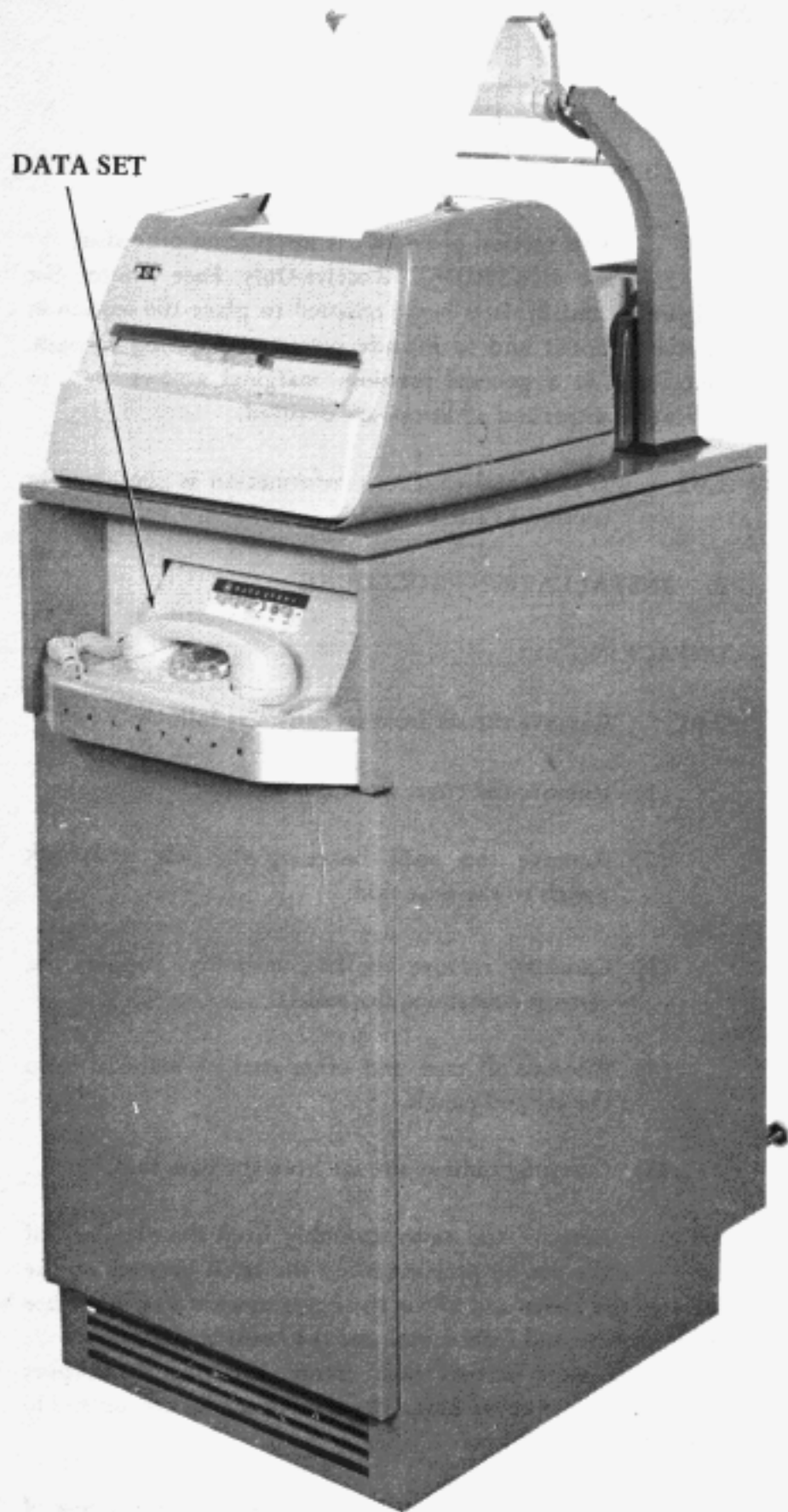

DATA SET

With Shelf for 202C Data Set or 804A
Data Auxiliary Set

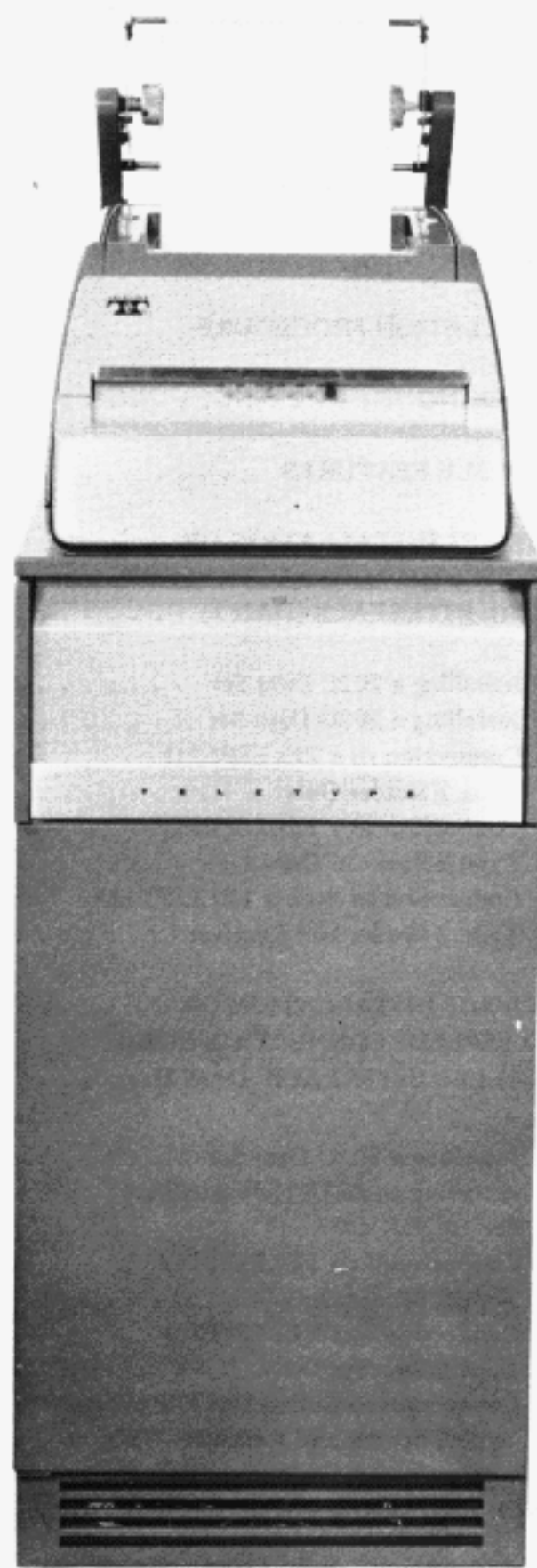

With Blank Panel for Use With 202D or
402D Data Set, or Direct Interface
With TELESPEED Equipment

Figure 1 - INKTRONIC Page Printer Set (RO)

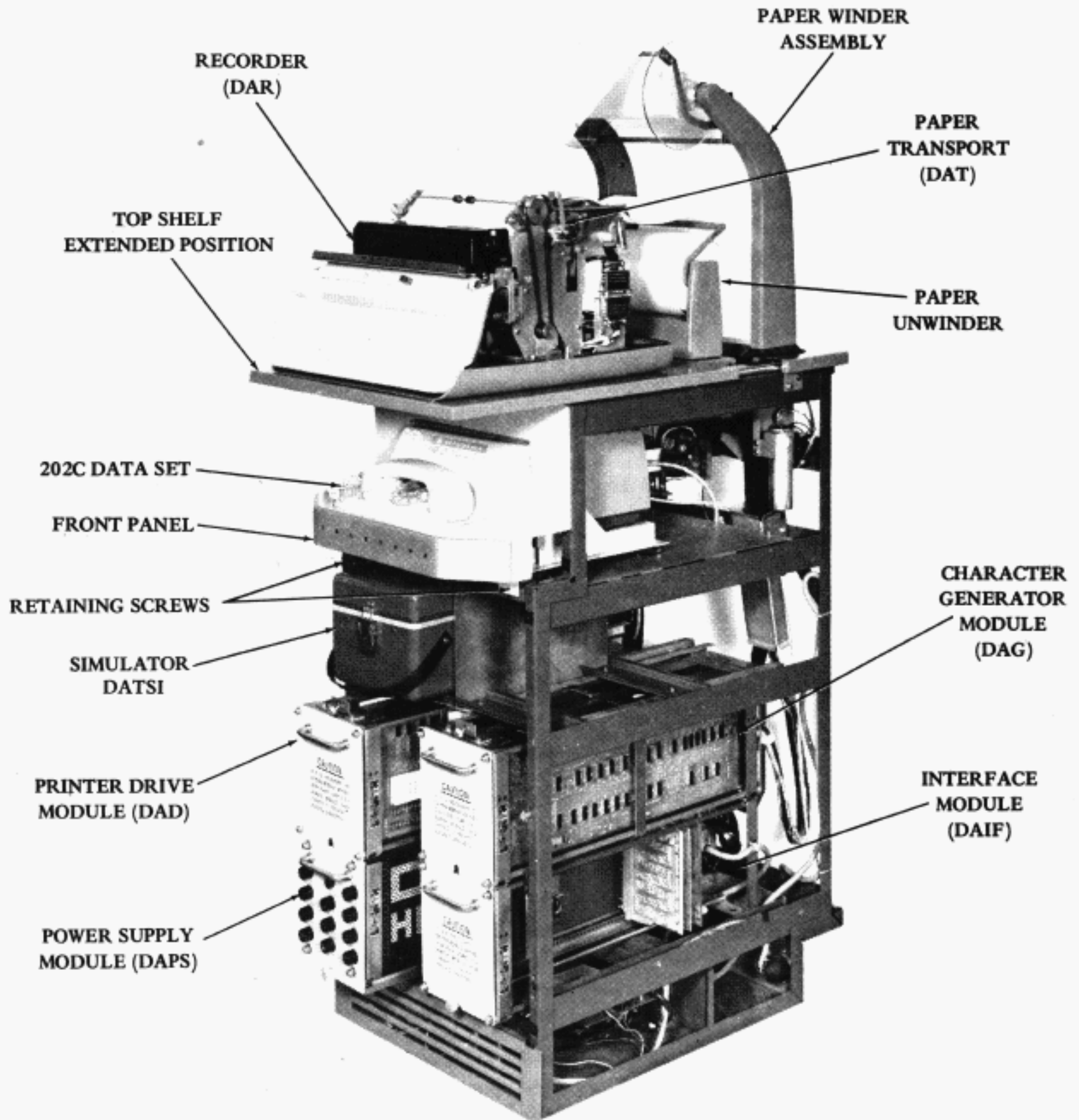

Note: Modules and shelf shown in extended positions. Slide into cabinet before installing data set.

Figure 2 - INKTRONIC Page Printer Set (RO) Showing Positions of Modules and Other Major Components

- (3) At the center rear of the transport, just forward of the screw that holds the circuit card assembly to the transport base.

VARIABLE FEATURES

- 2.03 Sets are shipped with variable features and modification kits as ordered. Only the data set, if required, must be installed in the field. If it should be necessary to use a set in a service or code arrangement other than that for which it was ordered, be sure that all requirements for the arrangement are met. These requirements are listed in Tables A and B. Functions may also be modified as shown in Table C.
- 2.04 The serial interface modification kit consists of a rotary switch and a cable assembly, while the parallel interface modification kit consists of a rotary switch, a cable assembly, and a relay package with power supply. Installation instructions are provided with each kit.
- 2.05 Interface strap option connections are shown in Figure 3. These connections may be made with the jumper clips illustrated. Only those clips listed should be present. Option A will be present in all sets using ASCII (United States of America Standard Code for Information Interchange) code and 7.00 or 7.42 unit Baudot code. Option B will be present in all sets using 5-level, 10-unit Baudot code.
- 2.06 A bit timer is part of the receiver distributor control cards MC180-MC183, located at position ZAS in the DAIF1 serial interface module (Figure 4). Sets using ASCII code may use either an MC180 or MC181 control card, depending on the desired operating speed. Sets using Baudot code may use an MC180, MC181, MC182, or MC183 control card, depending on the desired operating speed and number of units in the code (Table A). These cards are ordered by their part numbers, TP322180 through TP322183.
- 2.07 The discrete calling generator modification kit may be added to either a DAIF1 or DAIF2 interface that was ordered without it. This is done as follows:
- (1) Remove the mounting screws from the muslin bag included in the kit. Mount the TP199568 relay bracket assembly in position CE to the left of the NORM./TEST switch. The relay should be on top with the UP inscription on the upper edge.
 - (2) Mount the TP199570 signal generator assembly to the left of the relay bracket assembly in positions CU and CJ. The cable connector must be closer to the lower mounting rail.

- (3) Plug cable connector P1001 on the relay bracket assembly into receptacle J1001 on the signal generator assembly. Unlatch and remove jumper plug assembly CA1. Plug cable connector DAIF/CA1 into receptacle CA1.

- (4) Remove the rectangular cover from the signal generator mounting plate. Remove the code disc from the motor shaft by loosening the screw in the collar underneath the code disc.

- (5) Code the disc as specified in the installation order by using a screwdriver or diagonal cutter to break the narrow necks of the metal spokes to be opened. (Spokes are numbered as follows: The spoke connected to the long segment of the outer ring is the Start spoke, the spoke next to it in the counterclockwise direction is number 1, and the remaining spokes are numbers 2 through 14, in the same direction.)

CAUTION: DO NOT SCRATCH ANY OF THE OTHER CONDUCTING SURFACES.

- (6) After coding, clean the disc with a clean, soft cloth to remove all fingerprints and dirt. Replace the coding disc and cover on the signal generator plate.

- (7) Verify the disc coding by calling an identically coded TELESPEED Sender. Transmission should begin within five seconds after the TRANS START button on the printer control panel is pushed.

- 2.08 The discrete calling generator, if present when the printer is shipped, must be coded as described in 2.07, (5) through (7).

- 2.09 The paper advance rate, carriage return (CR), and line feed (LF) functions may be modified as shown in the table of Figure 5. The time required to feed out one line of paper when the PAPER ADVANCE button is depressed is changed by repositioning a wire at the rear of the DAG module. Simultaneous carriage return and line feed upon receipt of CR, available for ASCII only, is obtained by ordering a special MC152 card and adding a wire in the front of the DAG module. Simultaneous carriage return and line feed upon receipt of LF is obtained by placing an additional wire in the front of the DAG module.

DATA SET INSTALLATION OR "TELESPEED" CONNECTION FOR SERIAL INTERFACE (DAIF1)

- 2.10 If the printer has a DAIF1 serial interface module, it may be used with a 202C or 202D data set, or it may be connected to a TELESPEED Type 2 Sender, Receiver, or Sender and Receiver. For convenience, the data set should be installed or the TELESPEED connections should be made before the panels and doors are mounted on the printer.

TABLE A
SERVICE ARRANGEMENT REQUIREMENTS

TYPE OF OPERATION	OWN DATA SET REQUIRED	DATA SET OPTIONS REQ	INTERFACE MOD KIT	INT STRAP OPTION	RECEIVER DISTRIBUTOR CONTROL CARD	OWN DISCRETE CALLING GEN	FRONT ASSEMBLY
Stand Alone, Serial Interface 1050 wpm, With Discrete Calling	202C or Equivalent	ZE	None	DU	MC180	Yes	TP331140
Stand Alone, Serial Interface, 1200 wpm, With Discrete Calling	202C or Equivalent	ZE	None	DU	MC181-183*	Yes	TP331140
Stand Alone, Serial Interface, 1050 wpm, Without Discrete Calling, on Switched Network	202C or Equivalent	ZE	None	DU	MC180	No	TP331140
Stand Alone, Serial Interface, 1200 wpm, Without Discrete Calling, on Switched Network	202C or Equivalent	ZE	None	DU	MC181-183*	No	TP331140
Stand Alone, Serial Interface, 1050 wpm, Without Discrete Calling, on Private Line	202D or Equivalent	-	None	PL	MC180	No	TP331160
Stand Alone, Serial Interface, 1200 wpm, Without Discrete Calling, on Private Line	202D or Equivalent	-	None	PL	MC181-183*	No	TP331160
Interfaced Directly to TELESPEED Type 2 Sender	None	ZC, M	TP325191	DU or PL	MC180	No	TP331160
Interfaced Directly to TELESPEED Type 2 Receiver	None	ZE	TP325190	DU (1)	MC180	No	TP331160
Interfaced Directly to TELESPEED Type 2 Sender and Receiver	None	ZC, M	TP325192	DU (2)	MC180	No	TP331160
Stand Alone, Parallel Interface, With Discrete Calling	402D, With or Without 804A, or Equivalent	E**	None	DU	None	Yes	TP331110
Stand Alone, Parallel Interface, Without Discrete Calling, on Switched Network	402D Plus 804A, or Equivalent	E**	None	DU	None	No	TP331110
Stand Alone, Parallel Interface, Without Discrete Calling, on Private Line	402D or Equivalent	-	None	PL	None	No	TP331160

*See notes at end of table.

TABLE A

SERVICE ARRANGEMENT REQUIREMENTS (Continued)

TYPE OF OPERATION	OWN DATA SET REQUIRED	DATA SET OPTIONS REQ	INTERFACE MOD KIT	INT STRAP OPTION	RECEIVER DISTRIBUTOR CONTROL CARD	OWN DISCRETE CALLING GEN	FRONT ASSEMBLY
Interfaced Directly to TELESPEED Type 5 Sender	None	—	TP325195	PL	None	No	TP331160
Interfaced Directly to TELESPEED Type 5 Receiver	None	—	TP325195	PL	None	No	TP331160
Interfaced Directly to TELESPEED Type 5 Sender and Receiver	None	—	TP325195	DU	None	No	TP331160

Note 1: Interfaces above the double line are serial (DAIF1); interfaces below the double line are parallel (DAIF2).

Note 2: Only the data set options which are not factory-furnished are listed in the DATA SET OPTIONS REQ column. All other options remain unchanged.

*MC181 is for 10-unit code (ASCII or Baudot), MC182 is for 7.42-unit code (Baudot), and MC183 is for 7.00-unit code (Baudot).

**Data set option E required with data auxiliary set 804A only.

TABLE B
CODE REQUIREMENTS

INTERFACE	CODE	INTERFACE STRAP OPTION	CHARACTER GENERATOR CODE
Serial	No Field Changes Possible		
Parallel	7.00 or 7.42 Unit Baudot	A	DAG 2/AAC Only
	10-Unit Baudot	B	DAG 2/AAC Only
	No Other Field Changes Possible		

Note: Except in the case shown, the strap options supplied with the interface should not be disturbed.

TABLE C
FUNCTION VARIATIONS

FUNCTION		OBTAINABLE BY
Line Feed Rate (PAPER ADVANCE Pushbutton):	64 ms (160 wpm)	Standard Unless Ordered Otherwise
	32 ms (320 wpm)	Orderable or Wiring Change
CR on CR, LF on LF		Standard Unless Ordered Otherwise
CR and LF on CR (ASCII Only)		Orderable or Circuit Card Replacement
CR and LF on LF		Orderable or Wiring Change

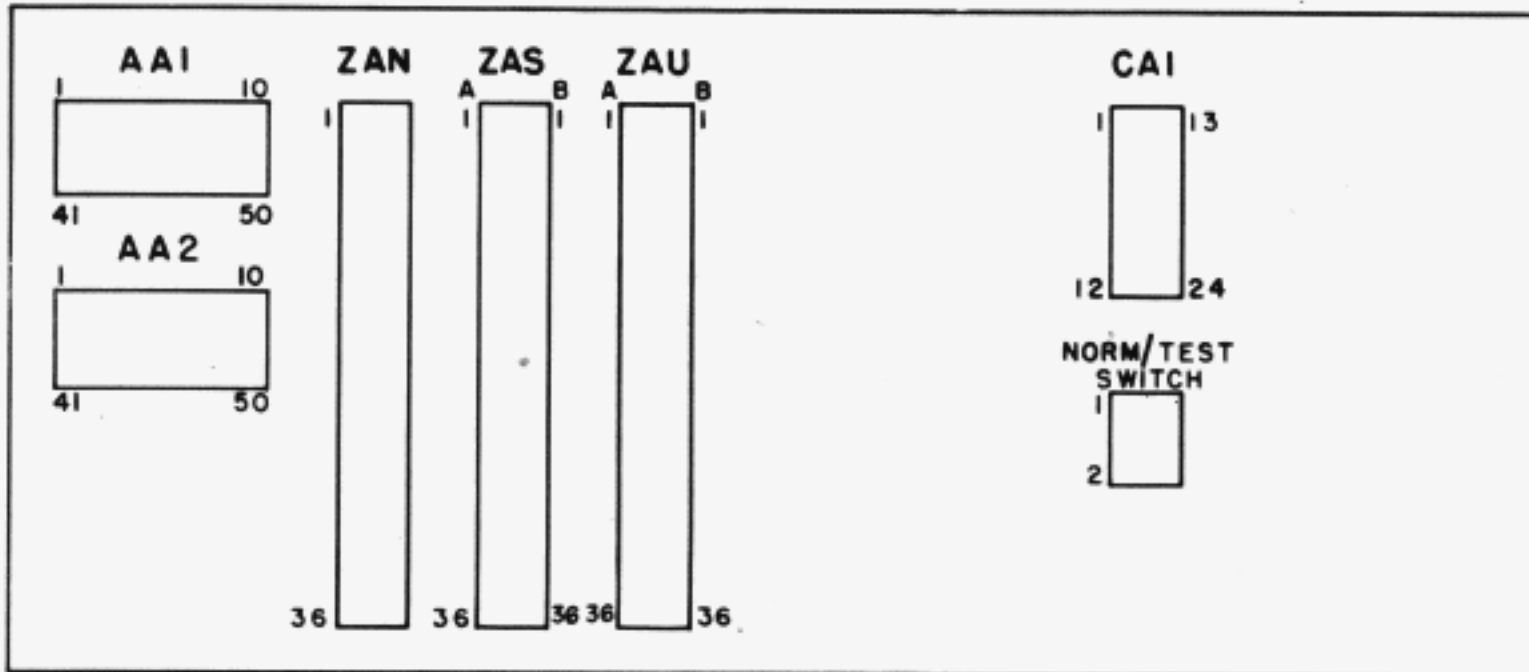

DAIF1 Serial Interface Terminal Location (Wiring Side View)

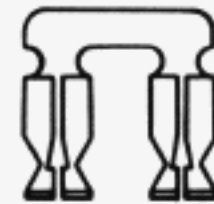

JUMPER CLIP

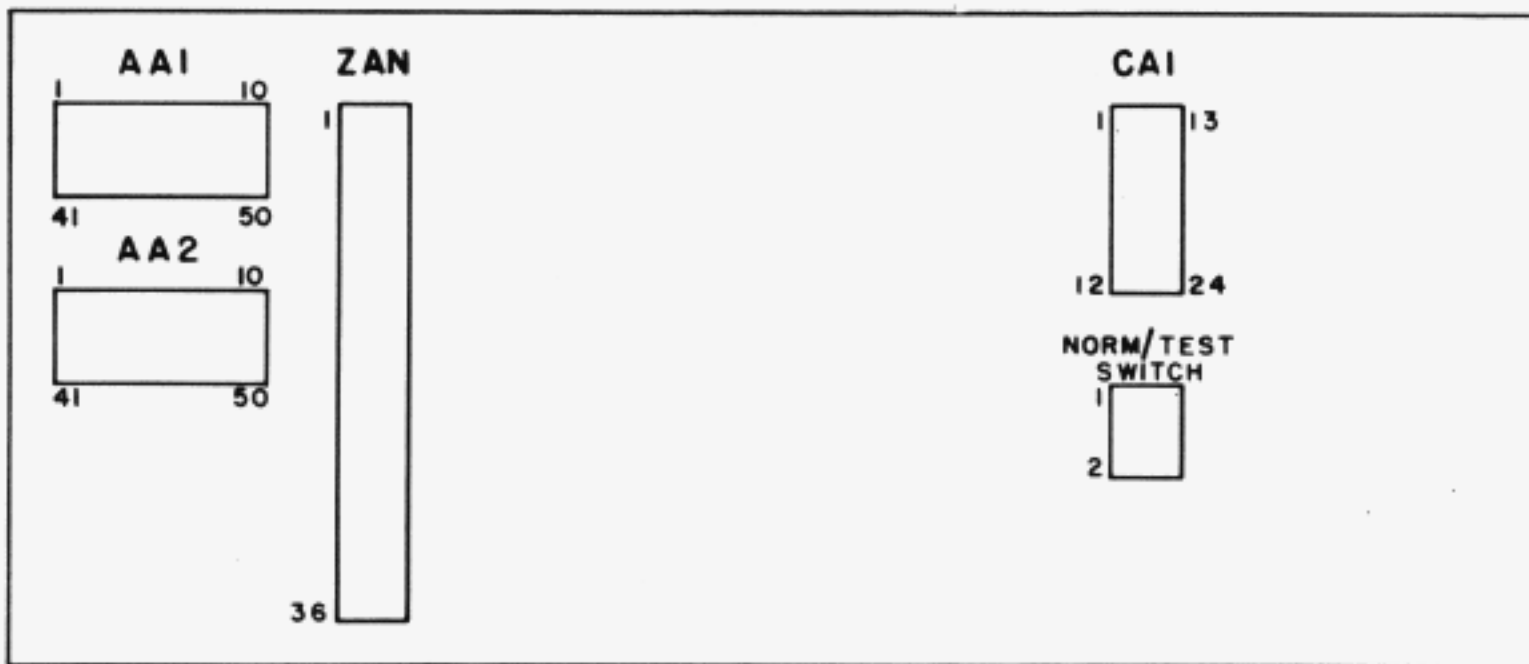

DAIF2 Parallel Interface Terminal Locations (Wiring Side View)

INTERFACE	STRAP OPTION	AA1 CONNECTIONS	AA2 CONNECTIONS	AA1/AA2 CONNECTIONS	ZAN CONNECTIONS
Serial	PL	26-36	25-35	None	25-27*
	DU	16-26	17-27, 18-28, 9-19	None	None
	DU (1)	16-26	17-27, 18-28, 9-19	AA1/26-AA2/25**	None
	DU (2)	16-26	17-27, 18-28, 9-19	None	None
Parallel	DU	16-26	18-28, 9-19, 20-30	None	None
	PL	None	None	None	None
Both	A	1-11, 2-12, 3-13, 4-14, 5-15	None	None	None
	B	11-21, 12-22, 13-23, 14-24, 15-25	None	None	None

*Bend jumper clip to make this connection.

**Make this connection by carefully soldering a piece of wire between the terminals.

Figure 3 - Interface Strap Options

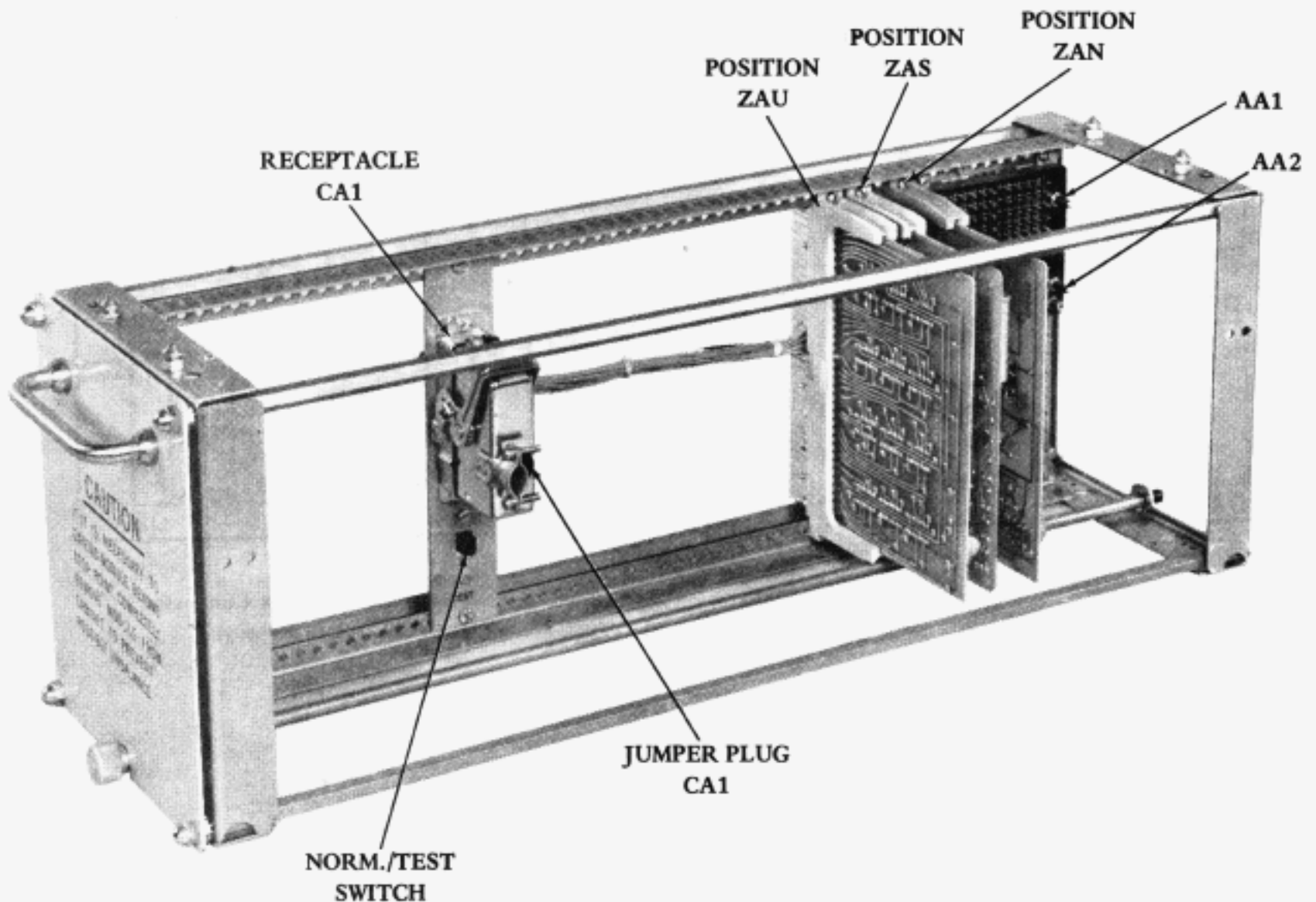

Note: DAIF2 parallel interface has circuit card in position ZAN only.

Figure 4 - DAIF1 Serial Interface Module Showing Location of Circuit Cards and Connectors

A. Installing a 202C Data Set

2.11 If the printer is shipped with a shelf assembly for use with a 202C data set, proceed as follows:

- (1) Remove the two retaining screws that hold the bottom of the data set shelf to the printer frame.
- (2) Pull the shelf forward so the two studs at the top disengage from the frame. Slide the shelf off the tracks and lay it on the floor or on a work table.
- (3) Place the 202C data set in position on the shelf. Move it as far toward the front as possible and secure it with the L-shaped bracket.
- (4) Carefully place the shelf flanges in the tracks and slide the shelf into the frame until the studs snap into the holes in the frame. Do not insert the two retaining screws, since the shelf must be moved forward to install the side panels after the connections are made.

- (5) Plug connector P202 of the printer into the rectangular receptacle at the rear of the data set.
- (6) Plug connector DAC/G1 into the circular receptacle at the rear of the data set.
- (7) The data set must be connected to the telephone line by means of its attached cable.
- (8) Install the panels and doors on the printer (2.23 and 2.24).

B. Installing a 202D Data Set

2.12 If the printer is shipped with a blank panel assembly for use with a 202D data set, proceed as follows:

- (1) Lay the data set on the perforated panel above the module housing, with the data set connectors to the rear of the printer frame.

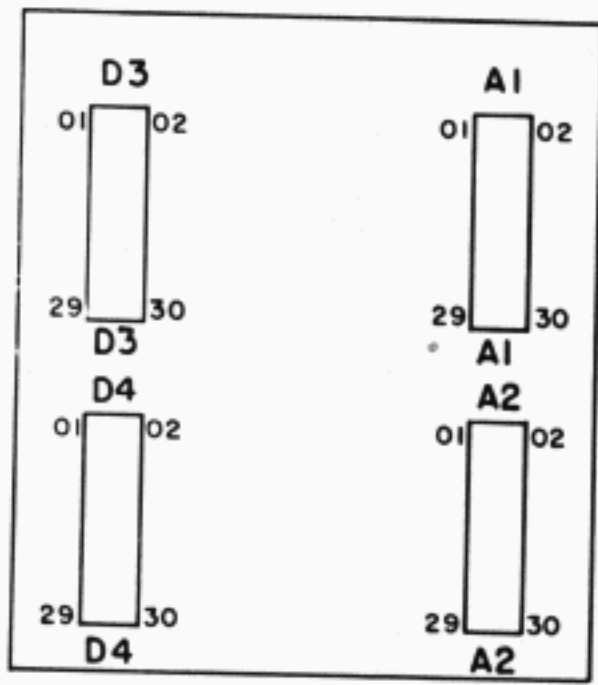

Front of DAG Module
(Coverplate Removed)

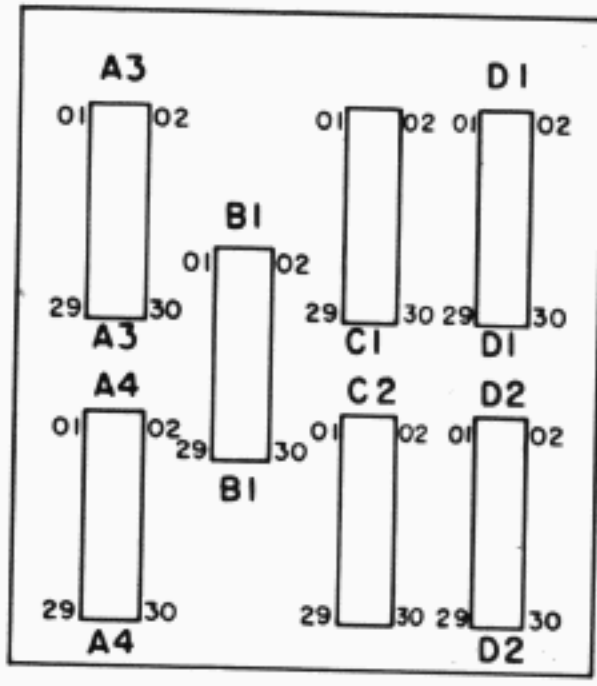

Rear of DAG Cable Connector
(Coverplate Removed)

Cable and Card Connectors for DAG Module

FUNCTION		MC152 CARD	FRONT CONNECTION	REAR CONNECTIONS
Line Feed Rate (PAPER ADVANCE Pushbutton):	64 ms (160 wpm)	-	-	D4-22 to D4-06
	32 ms (320 wpm)	-	-	D4-22 to D4-10
CR on CR, LF on LF		Standard	Standard	-
CR and LF on CR (ASCII only)		Special Order	A3-01 to D1-19	-
CR and LF on LF		Standard	D1-25 to D1-19*	-

Note: The front connection shown is in addition to the standard set wiring. Do not disturb any of these other wires. The paper advance rate and CR functions are independent of each other.

*Diode CR11 on circuit card TP322150 must be removed to provide this function.

Figure 5 - Function Variation Connections

- (2) Plug connector P202 of the printer into the rectangular receptacle at the rear of the data set.
- (3) Plug connector DAC/G1 into the circular receptacle at the rear of the data set.
- (4) The data set must be connected to the telephone line by means of its attached cable.
- (5) Install the panels and doors on the printer (2.23 and 2.24).

C. Connection to a TELESPEED Type 2 Sender Only

2.13 If the printer is shipped with a blank panel assembly and TP325191 modification kit for interface with a TELESPEED Type 2 Sender only, connect the printer to the sender as shown in Figure 6. The procedure is as follows:

- (1) Install the rotary switch, instruction plate, and knob on the switch panel.
- (2) Rest the switch panel on the perforated panel above the module housing in the printer frame, and assemble connector IIC of the cable to connector P202 of the printer.
- (3) Route the cable to the rear of the printer and through the hole in the lower part of the frame. Tie as necessary.
- (4) Remove the rear panel from the sender cabinet.
- (5) Route the cable through the hole in the lower right of the sender cabinet.
- (6) If the sender has a protected unattended transmitter recognizer module, remove connector DS from the rear of the data set in the sender, insert connector DS of the printer cable into the rectangular receptacle at the rear of the data set, and insert connector DSC of the printer cable into connector DS of the recognizer module.

If the sender does not have a protected unattended transmitter recognizer module, remove connector P701 from the rear of the data set in the sender, insert connector DS of the printer cable into the rectangular receptacle at the rear of the data set, and insert connector DSC of the printer cable into connector P701.

- (7) Place the rear panel on the sender cabinet.
- (8) Install the panels and doors on the printer (2.23 and 2.24).

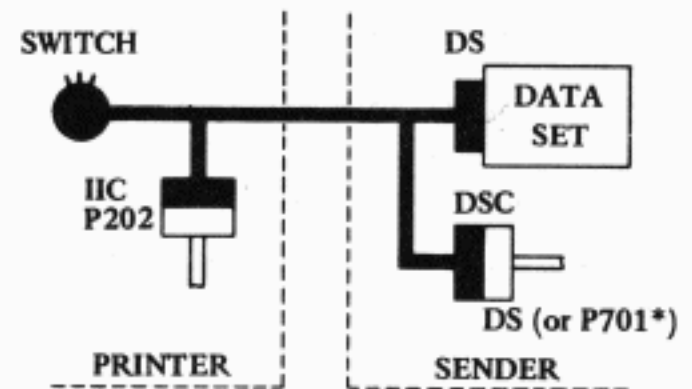

*P701 used if sender does not have recognizer module.

Figure 6 - Connection of INKTRONIC Printer to Type 2 TELESPEED Sender

D. Connection to a TELESPEED Type 2 Receiver Only

2.14 If the printer is shipped with a blank panel assembly and TP325190 modification kit for interface with a TELESPEED Type 2 Receiver only, connect the printer to the receiver as shown in Figure 7. The procedure is as follows:

- (1) Install the rotary switch, instruction plate, and knob on the switch panel.
- (2) Rest the switch panel on the perforated panel above the module housing in the printer frame, and assemble connector IIC of the cable to connector P202 of the printer.
- (3) Route the cable to the rear of the printer and through the hole in the lower part of the frame. Tie as necessary.
- (4) Remove the rear panel from the receiver cabinet.
- (5) Route the cable through the hole in the lower right of the receiver cabinet.
- (6) If the receiver has a protected unattended transmitter identifier module, insert connector DS of the printer cable into the rectangular receptacle at the rear of the data set, and insert connector DSC of the printer cable into connector DS of the identifier module in the receiver.

If the receiver does not have a protected unattended transmitter identifier module, remove connector P701 from the rear of the data set in the receiver, insert connector DS of the printer cable into the rectangular receptacle at the rear of the data set, and insert connector DSC of the printer cable into connector P701.

- (7) Place the rear panel on the receiver cabinet.
- (8) Install the panels and doors on the printer (2.23 and 2.24).

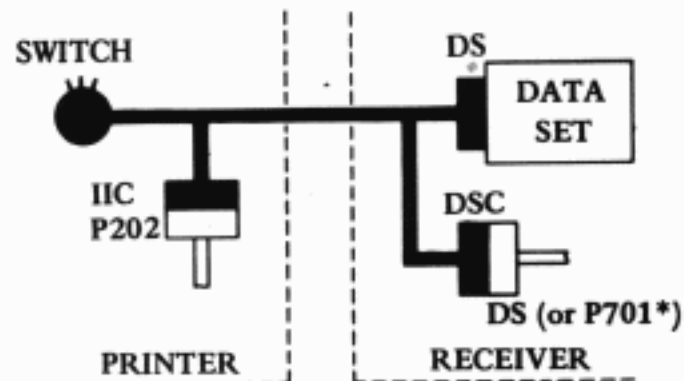

*P701 used if receiver does not have identifier module.

Figure 7 - Connection of INKTRONIC Printer to Type 2 TELESPEED Receiver

E. Connection to Both a TELESPEED Type 2 Sender and Receiver

2.15 If the printer is shipped with a blank panel assembly and TP325192 modification kit for interface with both a TELESPEED Type 2 Sender and Receiver, connect the printer to the sender and receiver as shown in Figure 8. The procedure is as follows:

- (1) Install the rotary switch, instruction plate, and knob on the switch panel of the printer.
- (2) Rest the switch panel on the perforated panel above the module housing in the printer frame, and assemble connector IIC of the cable to connector P202 of the printer.
- (3) Route the cable to the rear of the printer and through the hole in the lower part of the frame. Tie as necessary.
- (4) Remove the rear panel from the sender and receiver cabinets.
- (5) Route connector DSCR of the cable into the receiver cabinet through the hole in the lower right of the rear panel.
- (6) Route connectors DS, DSCS, and RTC of the cable into the sender cabinet through the hole in the lower right of the rear panel.

- (7) If the receiver has a protected unattended transmitter identifier module, disconnect connector RT (on the Y cable from the sender) from connector DS (on the cable from the identifier module in the receiver), and insert connector DSCR of the printer cable into connector DS of the cable from the identifier module.

If the receiver does not have a protected unattended transmitter identifier module, disconnect connector RT (on the Y cable from the sender) from connector P701 of the receiver, and insert connector DSCR of the printer cable into connector P701 of the receiver.

- (8) Pull connector RT of the Y cable into the sender cabinet through the hole in the lower right of the rear panel.
- (9) Insert connector RTC of the printer cable into connector RT of the Y cable of the sender.
- (10) If the sender has a LOCAL control switch, remove connector AL (on the T cable from the sender) from the rear of the data set in the sender, and insert

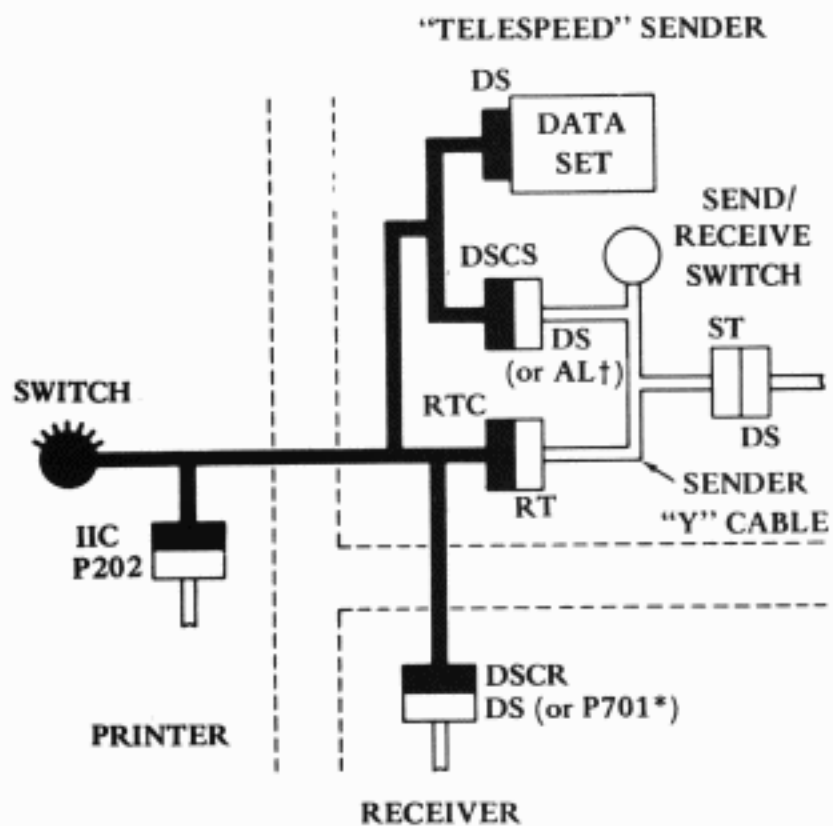

*P701 used if receiver does not have identifier module.

†AL of "T" cable used if sender has LOCAL control switch.

Figure 8 - Connection of INKTRONIC Printer to Type 2 TELESPEED Sender and Receiver

connector DSCS of the printer cable into connector AL of the T cable.

If the sender does not have a LOCAL control switch, remove connector DS (on the Y cable from the sender) from the rear of the data set, and insert connector DSCS of the printer cable into connector DS of the Y cable.

- (11) Insert connector DS of the printer cable into the rectangular receptacle at the rear of the data set.
- (12) Place the rear panels on the sender and receiver.
- (13) Install the panels and doors on the printer (2.23 and 2.24).

DATA SET INSTALLATION OR "TELESPEED" CONNECTION FOR PARALLEL INTERFACE (DAIF2)

2.16 If the printer has a DAIF2 parallel interface module, it may be used with a 402D data set (with or without an 804A data auxiliary set), or it may be connected to a TELESPEED Type 5 Sender, Receiver, or Sender and Receiver. For convenience, the data set and data auxiliary set (if used) should be installed or the connections to the TELESPEED system should be made before the panels and doors are mounted on the printer.

A. Installing a 402D Data Set

2.17 If a 402D data set is used in the installation, it is mounted at some point outside the printer cabinet, but close enough to permit interconnection with the DAIF2 interface (and 804A data set, if used). The connections are made as follows:

- (1) Plug connector P402 of the printer into the rectangular receptacle on the rear of the data set.
- (2) The data set must be connected through appropriate fittings to the telephone line and to the ac power line.

Note: Ac connector DAC/G1 of the printer cannot be used for connection to an external data set such as a 402D.

- (3) If an 804A data auxiliary set is not used, install the panels and doors on the printer (2.23 and 2.24).

B. Installing an 804A Data Auxiliary Set

2.18 If the printer is shipped with a shelf assembly for use with an 804A data auxiliary set in addition to the 402D data set, install the data auxiliary set as follows:

- (1) Remove the two retaining screws that hold the bottom of the set shelf to the printer frame.
- (2) Pull the shelf forward so the two studs at the top disengage from the frame. Slide the shelf off the tracks and lay it on the floor or on a work table.
- (3) Place the 804A data auxiliary set in position on the shelf. Move it as far toward the front as possible and secure it with the L-shaped bracket.
- (4) Carefully place the shelf flanges in the tracks, and slide the shelf into the frame until the studs snap into the holes in the frame. Do not insert the retaining screws, since the shelf must be moved forward to install the side panels after the connections are made.
- (5) The data auxiliary set must be connected by appropriate fittings to the data set.
- (6) Install the panels and doors on the printer (2.23 and 2.24).

C. Connection to a TELESPEED Type 5 Sender Only

2.19 If the printer is shipped with a blank panel assembly and TP325195 modification kit for interface with a TELESPEED Type 5 Sender only, connect the printer to the sender as shown in Figure 9. The procedure is as follows:

- (1) Remove the stop tab from position 1 on the stop plate of the rotary switch, and mount the switch, instruction plate, and knob on the switch panel of the printer.
- (2) Lay the power supply and relay card assembly on the perforated panel above the module housing. Rest the bottom of the switch panel on the front part of the perforated panel.
- (3) Assemble connector J402 of the cable to connector P402 of the DAIF2 interface module.
- (4) Route the cable to the rear of the printer, and through the hole in the lower part of the frame.
- (5) Remove the rear panel from the sender cabinet and route the branch of the cable containing the DS and DSCS connectors through the hole at the lower left rear of the cabinet.
- (6) Remove the connector from the data set in the sender, and connect the DS connector of the cable to the data set.

- (7) Connect the DSCS connector of the cable to the data set connector of the sender.
- (8) Tie the branch of the cable containing the DS and DSCR connectors back to the main cable.
- (9) Place the rear panel on the sender.
- (10) Install the panels and doors on the printer (2.23 and 2.24).

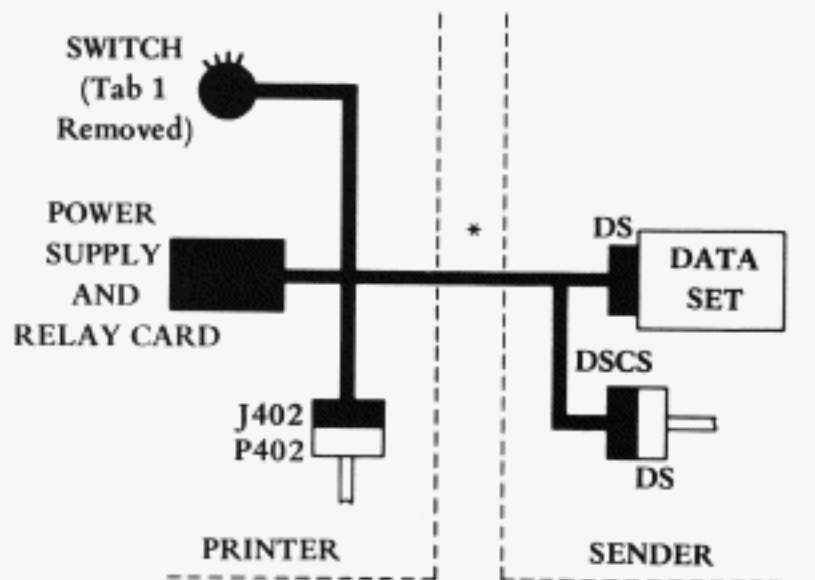

Figure 9 - Connection of INKTRONIC Printer to Type 5 TELESPEED Sender

D. Connection to a TELESPEED Type 5 Receiver Only

2.20 If the printer is shipped with a blank panel assembly and TP325195 modification kit for interface with a TELESPEED Type 5 Receiver only, connect the printer to the receiver as shown in Figure 10. The procedure is as follows:

- (1) Mount the rotary switch, instruction plate, and knob on the switch panel of the printer.
- (2) Lay the power supply and relay card assembly on the perforated panel above the module housing. Rest the bottom of the switch panel on the front part of the perforated panel.
- (3) Assemble connector J402 of the cable to connector P402 of the DAIF2 interface.

- (4) Route the cable to the left rear of the printer cabinet, down the left rear corner and out the hole at the lower left of the cabinet. Tie the cable as necessary.
- (5) Remove the back panel of the receiver cabinet and route the branch of the cable containing the DS and DSCR connectors through the hole at the lower left rear of the cabinet.
- (6) Remove the connector from the data set in the sender, and connect the DS connector of the cable assembly to the data set.
- (7) Connect the DSCR connector of the cable to the data set connector of the receiver.
- (8) Tie the branch of the cable containing the DS and DSCR connectors back to the main cable.
- (9) Place the rear panel on the receiver.
- (10) Install the panels and doors on the printer (2.23 and 2.24).

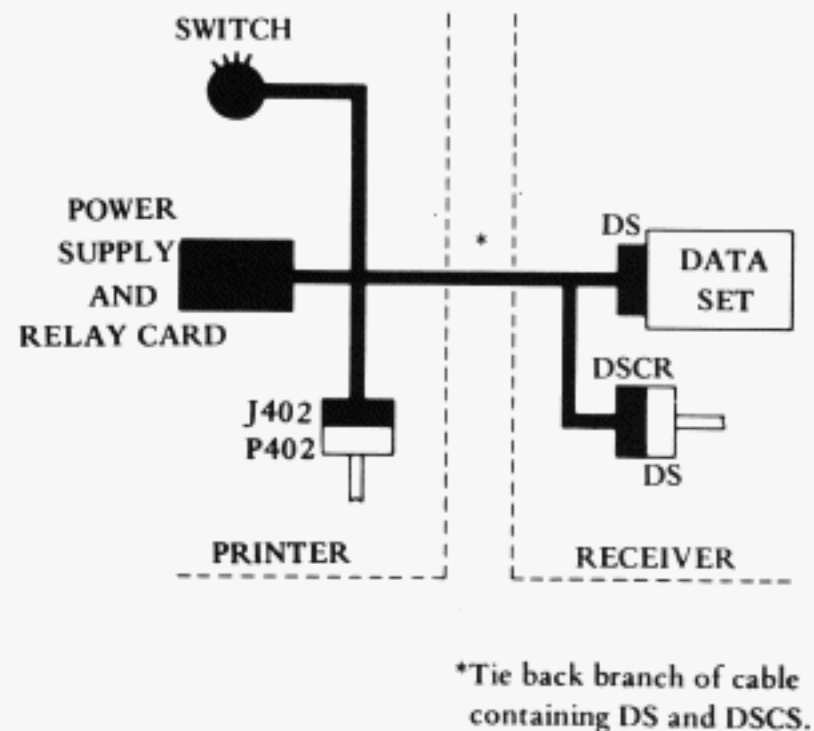

Figure 10 - Connection of INKTRONIC Printer to Type 5 TELESPEED Receiver

E. Connection to Both a TELESPEED Type 5 Sender and Receiver

2.21 If the printer is shipped with a blank panel assembly and TP325195 modification kit for interface with both a TELESPEED Type 5 Sender and Receiver, connect the printer to the sender and receiver as shown in Figure 11. The procedure is as follows:

- (1) Remove the stop tabs from switch positions 1, 5, 6, and 7 on the stop plate of the rotary switch, and mount the switch, instruction plate, and knob on the switch panel of the printer.
- (2) Lay the power supply and relay card assembly on the perforated panel above the module housing. Rest the switch panel on the front part of the perforated panel.
- (3) Assemble connector J402 of the cable to connector P402 of the DAIF2 interface.
- (4) Route the cable to the left rear of the printer, down the left rear corner and out the hole at the lower left of the cabinet. Tie the cable as necessary.
- (5) Remove the back panels from the sender and receiver cabinets. Route the branch of the cable containing the DS and DSCS connectors through the hole at the lower left rear of the sender cabinet. Route the branch containing the DS and DSCR connectors through the hole at the lower left rear of the receiver cabinet.
- (6) Remove the connectors from the data sets in the sender and receiver and connect the DS connectors of the respective cable branches to the data sets.
- (7) Connect the DSCS connector of the cable assembly to the data set connector of the sender.
- (8) Connect the DSCR connector of the cable assembly to the data set connector of the receiver.

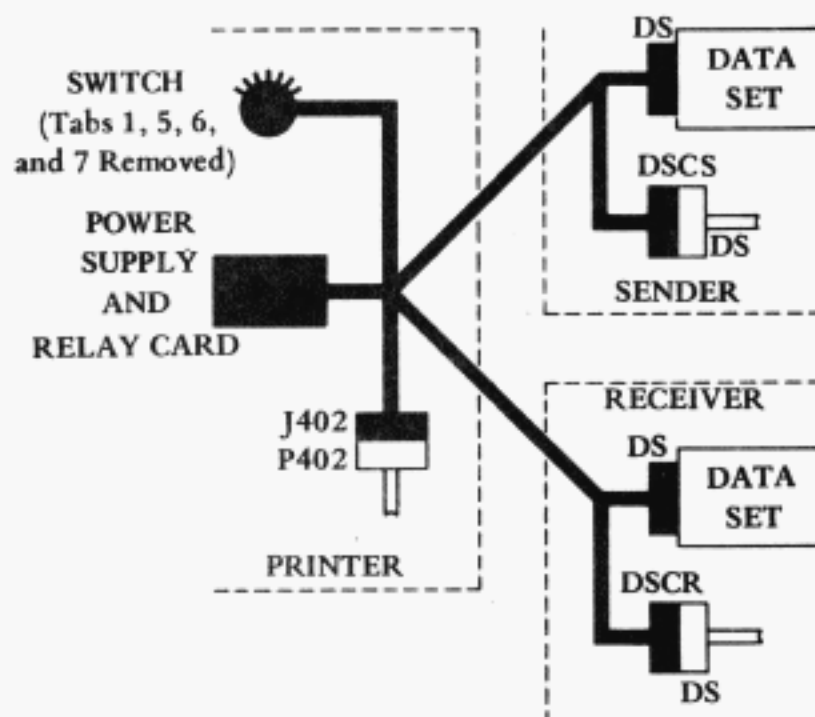

Figure 11 - Connection of INKTRONIC Printer to Type 5 TELESPEED Sender and Receiver

- (9) Place the rear panels on the sender and receiver.
- (10) Install the panels and doors on the printer (2.23 and 2.24).

PANEL AND DOOR INSTALLATION

2.22 Hardware necessary to install the panels and doors is in a muslin bag attached to the printer. Remove the bag and sort the hardware.

2.23 If the set has a shelf assembly for a 202C data set or an 804A data auxiliary set (Figure 12), proceed with the installation as follows:

- (1) With the two retaining screws removed from the bottom of the shelf, pull the shelf forward so the two studs at the top disengage from the frame.
- (2) Set each side panel in place and attach it to the frame with four TP148756 sheet metal screws at the front and three at the rear.
- (3) Screw a gray plastic bumper into the large hole near the bottom rear of each side panel until it stops against the frame.

Note: The bumpers prevent the set from being pushed too close to a wall and thus assure adequate air circulation from the rear. Insufficient air cooling will result in component failures due to overheating.

- (4) Slide the shelf into the cabinet until the studs snap into the holes on the frame. Secure the shelf with the retaining screws.
- (5) Install the front door by inserting the bottom plunger into the hole in the bracket at the lower left side of the frame, then depressing the top plunger and snapping it into the upper bracket. Adjust the door latch by loosening the two hex head screws and positioning the latch as required. Tighten the two hex head screws.
- (6) Assemble the TP172715 captive screw in the rear panel. Place the rear panel on the cabinet.

2.24 If the set is shipped with a switch panel and a blank front panel for use with a 202D data set, a 402D data set without an 804A data auxiliary set, or for direct interface with a TELESPEED unit (Figure 13), proceed with the installation as follows:

- (1) Set each side panel in place and attach it to the frame with four TP148756 sheet metal screws at the front and three at the rear.

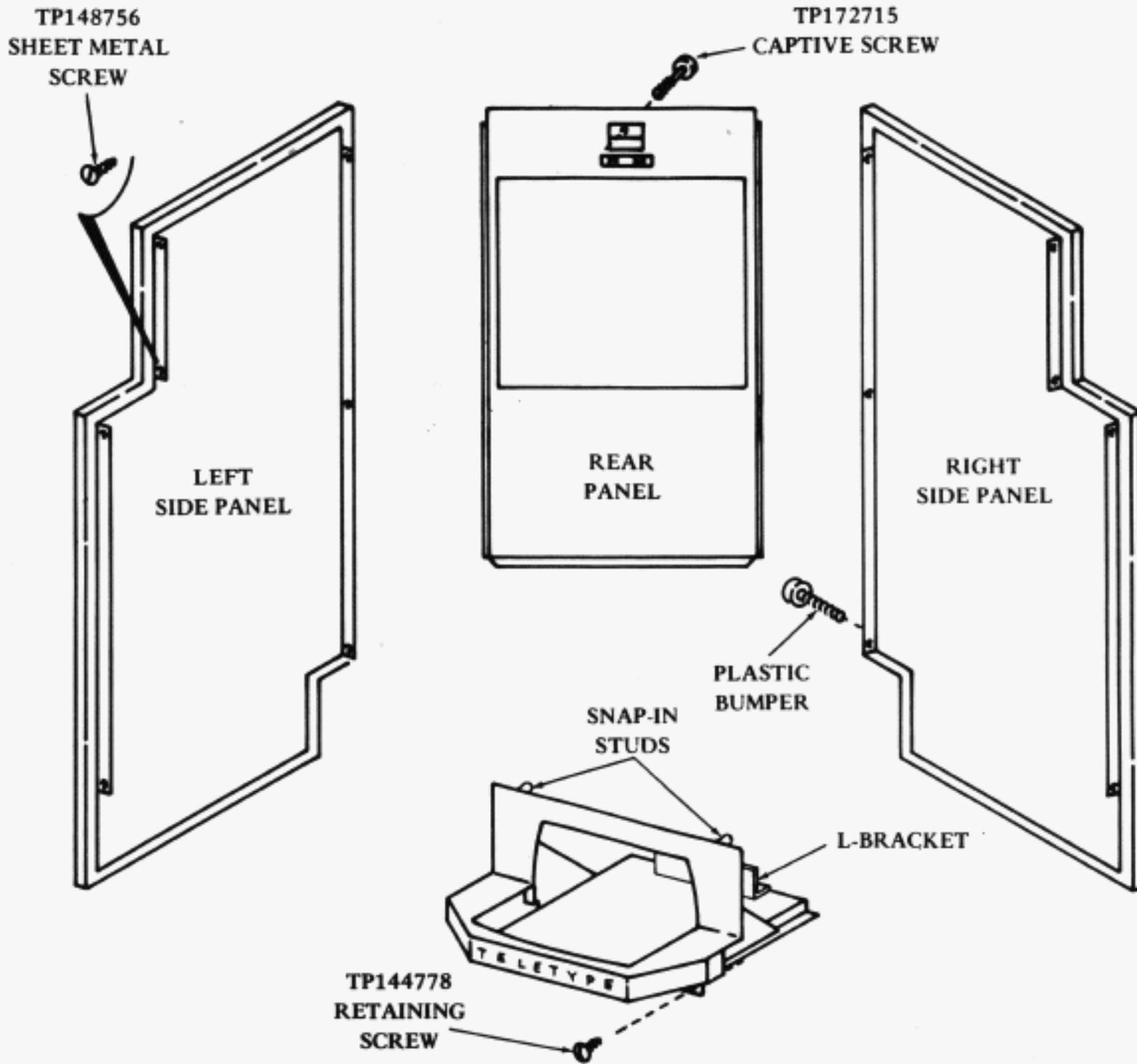
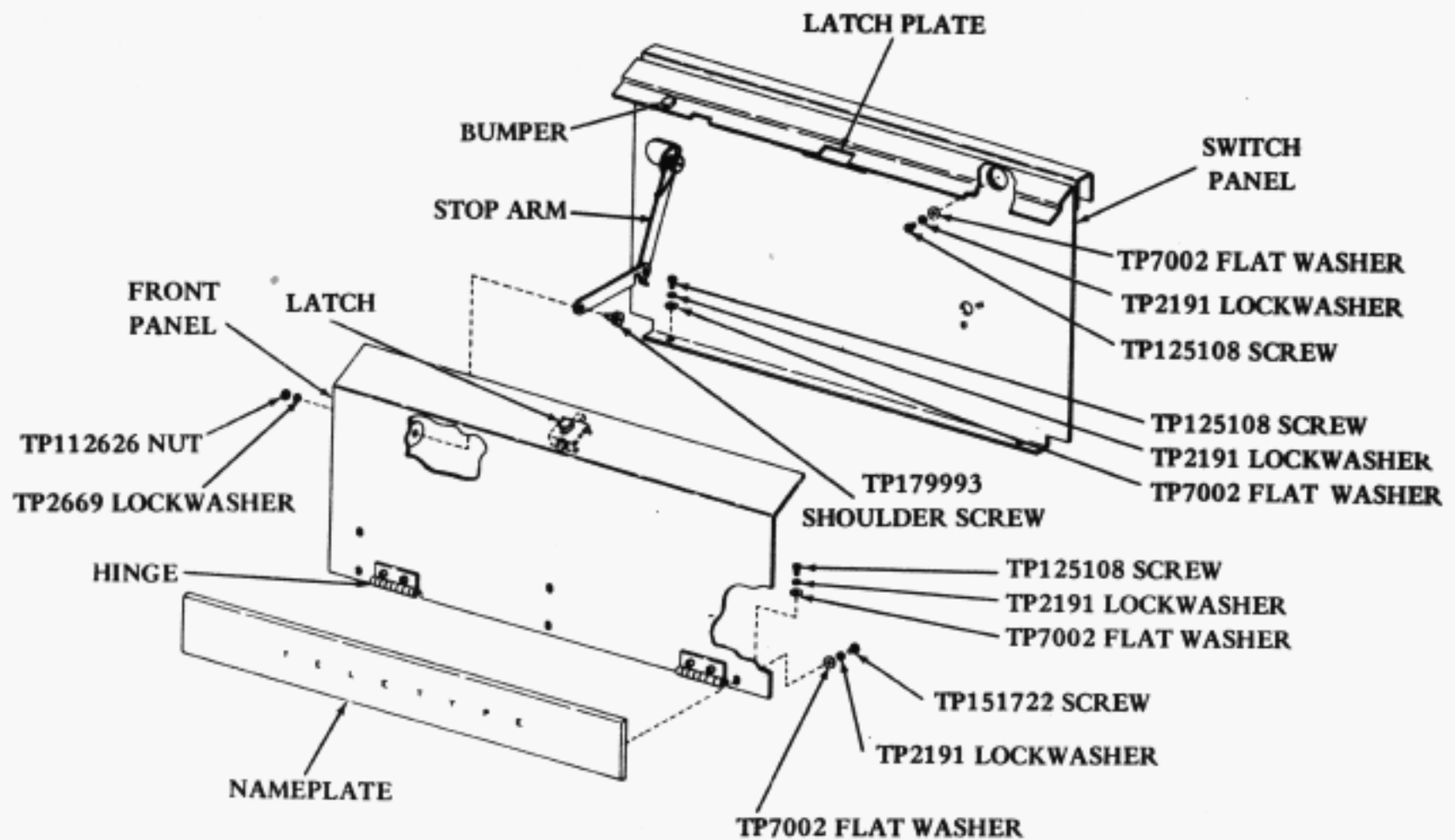

Figure 12 - Installation of Panels With Data Set Shelf Assembly



Note: Side and rear panels installed as in Figure 12.

Figure 13 - Installation of Blank Front Panel Assembly

- (2) Screw a gray plastic bumper in the large hole near the bottom rear of each side panel until it stops against the frame.

Note: The bumpers prevent the set from being pushed too close to a wall and thus assure adequate air circulation from the rear. Insufficient air cooling will result in component failures due to overheating.

- (3) Position the switch panel so the sides are flush with the top of the frame and the bottom flange of the panel is resting on the perforated panel inside the frame. Secure the panel with four TP125108 screws, TP2191 lockwashers, and TP7002 flat washers.

- (4) Screw the front panel hinges to the frame with four TP125108 screws, TP2191 lockwashers, and TP7002 flat washers. Do not tighten the screws at this time.

- (5) Attach the stop arm on the switch panel to the bracket on the front panel with a TP179993 shoulder screw, TP2669 lockwasher, and TP112626 nut.

- (6) Center the front panel between the side panels and tighten the four hinge screws to the frame. Loosen the screws that hold the front panel to the hinges, and adjust the panel up or down until it seats properly on the bumpers at the top of the switch panel. Tighten the hinge screws.

- (7) With the latch plate mounting nuts friction tight, adjust the latch plate so it engages the latch securely when the front panel is closed. Tighten the nuts on the latch plate.

- (8) Mount the nameplate on the front panel with six TP151722 screws, TP2191 lockwashers, and TP7002 flat washers.

- (9) Install the front door by inserting the bottom plunger into the hole in the bracket at the lower left side of the frame, then depressing the top plunger and snapping it into the hole in the upper bracket. Adjust the door latch by loosening the two hex screws and positioning the latch as required. Tighten the hex screws.

- (10) Assemble the TP172715 captive screw in the rear panel. Place the rear panel on the cabinet.

PAPER INSTALLATION

2.25 The printer accepts standard, single copy, 8-1/2 inch wide, teletypewriter paper rolls up to 5 inches in diameter. Install a roll by inserting the paper unwinder spindle (Figure 14) into the roll, pushing the slack arm and low paper alarm arm aside, and setting the spindle on its supports.

2.26 Place the end of the paper roll on top of the rear guide pan and thread it through the paper transport as shown on the decal affixed to the inside of the cover, as follows:

- (1) Push the paper pressure roller arm to its open position, then push in and release the idler roller assembly latches. Pivot the idler roller assembly up and push about 6 to 8 inches of paper across the rear guide pan and over the front guide pan.

- (2) Feed the paper down the front guide pan and up across the face of the platen. Lift the pressure roller on the paper tensioner and feed the paper across the paper tensioner roller. Release the paper tensioner pressure roller.

- (3) If a paper winder is not present or will not be used, push the paper roller arm to its closed position and push the idler roller assembly down until it latches.

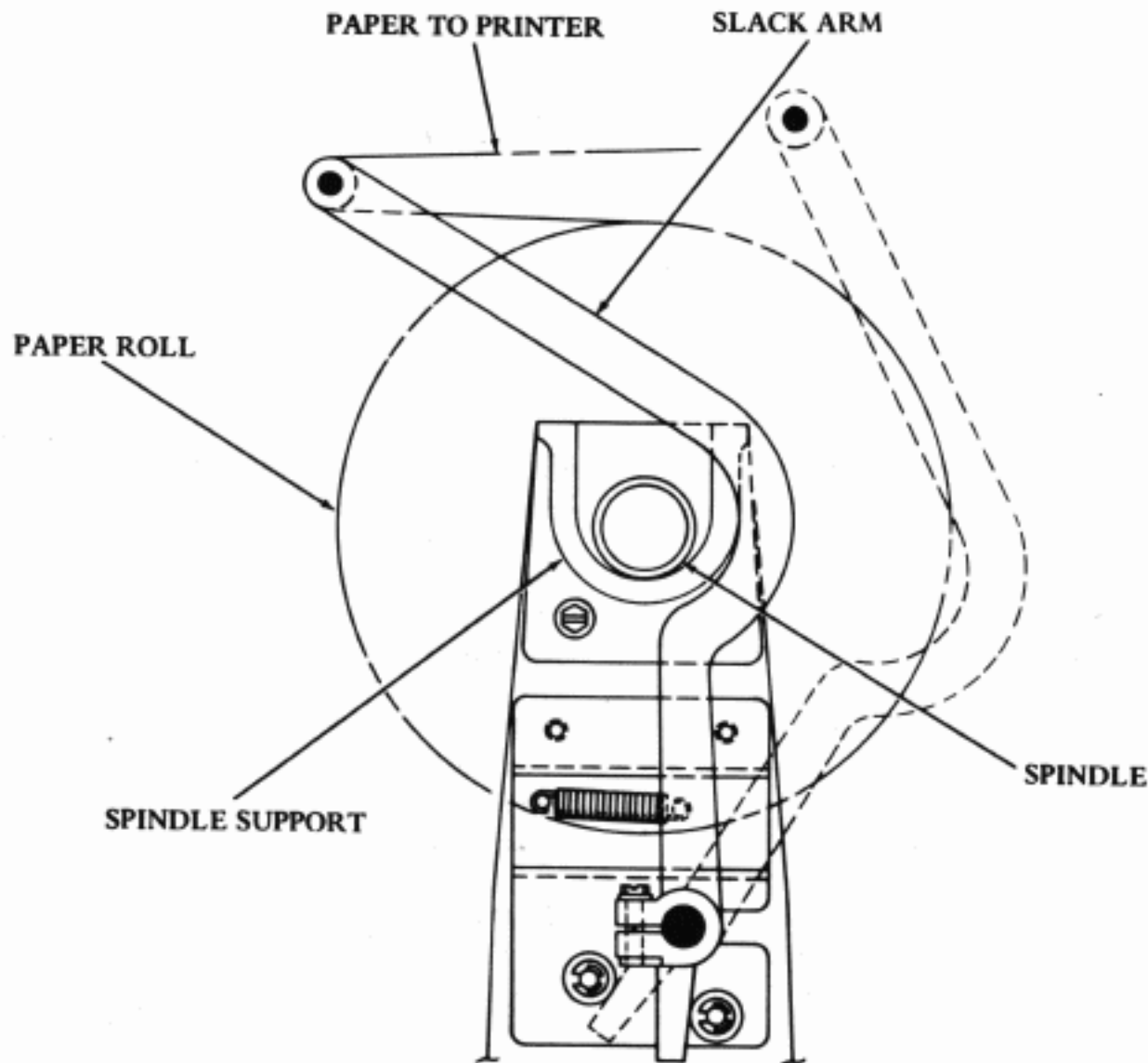

(Low Paper Arm Not Shown)

Figure 14 - Paper Unwinder

2.27 If a paper winder is used, thread the end of the paper from the platen over the paper winder slack arm (Figure 15) and through the metal rods. Rotate the winder reel a few times to secure the paper.

2.28 Push the paper pressure roller arm to its closed position and push the idler roller assembly down until it latches.

INK SUPPLY

2.29 To fill the recorder tank with ink, loosen the nuts on each end of the recorder tank cover (Figure 16) and pivot them down. Remove the cover and add approximately one bottle of INKTRONIC 1A ink (TP301168).

Note: Use only this ink. Be careful not to spill any; it has powerful staining properties.

2.30 Replace the tank cover. Pivot the two nuts up and tighten them.

2.31 It will be necessary to add ink again after about 40 to 50 rolls of paper have passed through the printer. To check on the ink level, remove the tank cover as described in 2.29. If the connecting leads are exposed near the bottom of the pump, add about one-half bottle of ink. Do not fill so full that the top of the ink pump is covered. (Overfilling may cause serious electrical problems.) Replace the tank cover. Pivot the nuts up and tighten them.

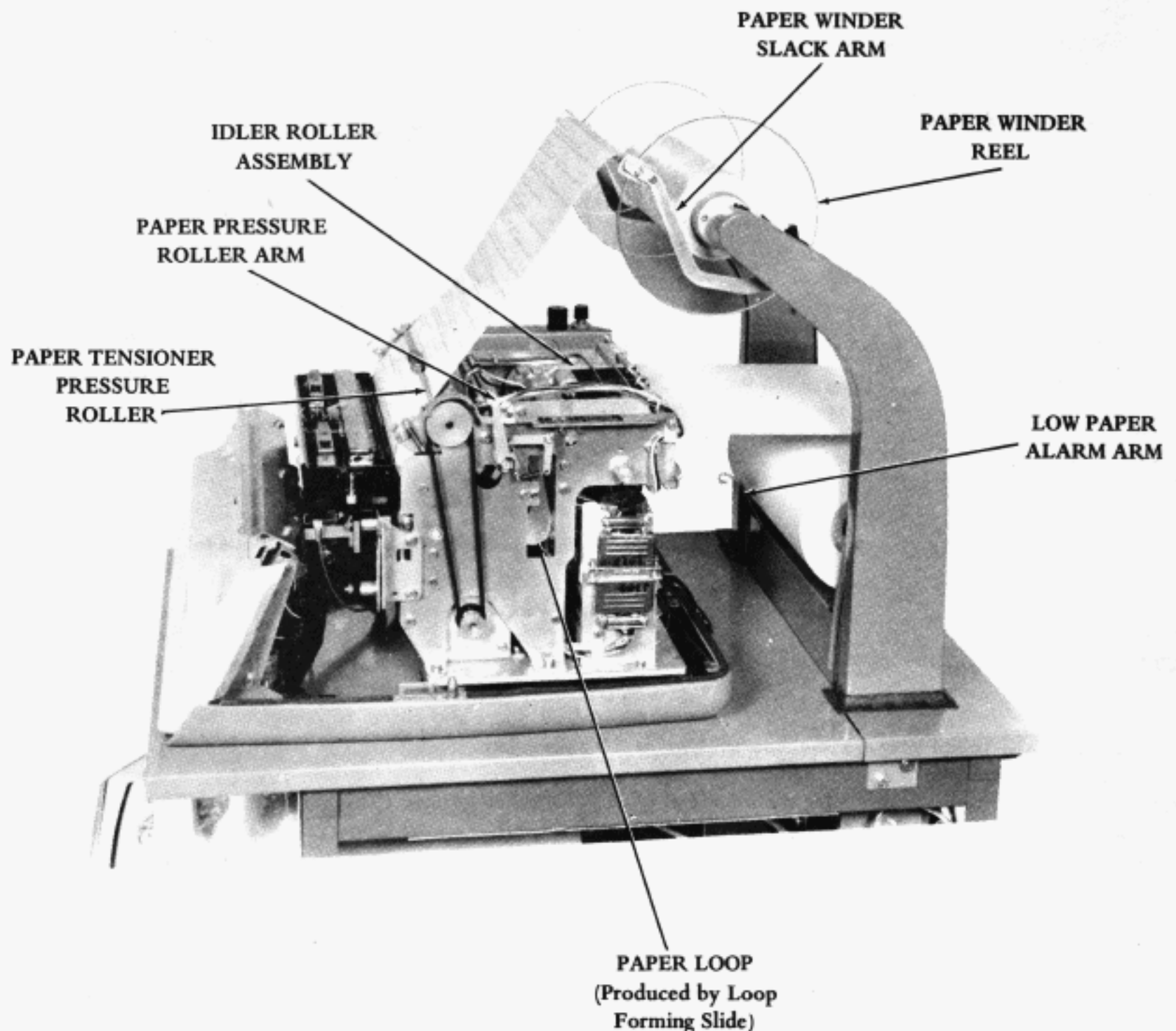

Figure 15 - Paper Transport Mechanism With Paper Properly Installed (Paper Winder Included)

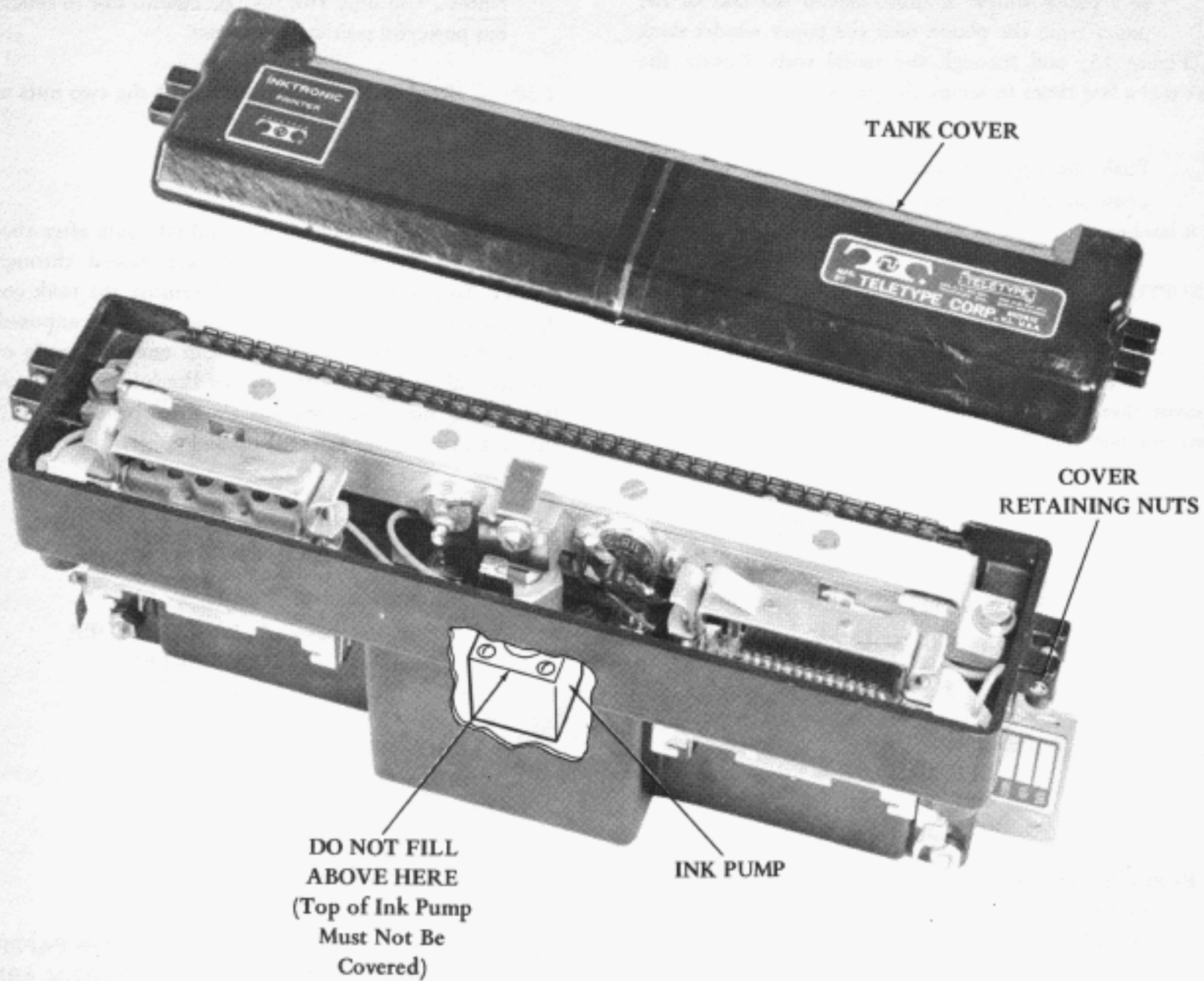

Figure 16 - Recorder With Cover Removed to Show Inside of Tank (Cutaway Shows Ink Pump)

ELECTRICAL CONNECTIONS

2.32 Connect the round plug on the line cord to its mating receptacle in the lower left of the rear of the cabinet, as viewed from the rear. Plug the other end of the line cord into a standard 117 v ac, 60 Hz outlet.

2.33 Turn on the ac ON/OFF toggle switch, located inside the front door on the cabinet frame. Close all doors and covers to complete the high voltage interlock circuitry.

2.34 Allow 15 minutes for the ink to warm up. The printer is now ready for operational testing.