

B.K. Martin Book C60

**BELL SYSTEM PRACTICES**  
Station Installation and Maintenance

**SECTION C63.269**  
Issue 4, 11-1-43  
AT&T Co Standard

## **LINE AND RINGER CONNECTIONS**

### **MAIN AND EXTENSION STATIONS**

#### **1. GENERAL**

1.01 This section covers the line, ringer and loud ringing bell connections for sidetone and anti-sidetone main and extension stations of the following classes of service.

##### **Ten and Twenty—Party Bridged and Divided Code Ringing**

1.02 This section is reissued to extend the scope of the section to manual and dial offices; cancel Section C63.267; remove time interval information in paragraph 2.01; correct code ringing information in paragraph 2.06, and bring other information up to date.

1.03 The ringing arrangements covered herein apply to exchange districts served by the types of offices listed in 2.02 to 2.16.

1.04 In certain of these offices the equipment arrangements provide for as many as twenty bridged or divided code ringing stations per line, subject to loop limitations and other restrictions specified hereinafter.

1.05 The code ringing codes are indicated for both ten and twenty-party lines. The ringing code and, in the case of divided code ringing, whether the ringing is applied to the tip or ring side of the line is in some cases determined by the last digit of the station number and in other cases by the last and another digit of the station number.

1.06 In the assignments made incident to the connection and disconnection of stations on divided code ringing lines consideration is given to proper balance of ringing equipment connected to these lines as covered in the section entitled "Ringer Connection Limitations—Non-Polarized Ringing Lines." Installers shall not, therefore, make any changes in the number of ringing bridges or their connections without proper authorization.

1.07 Bridged ringing party station numbers are of course assigned without restrictions.

**C63.269**

Page 1

**LINE AND  
RINGER  
CONNECTIONS  
MAIN AND  
EXTENSION  
STATIONS**

**PIONEER MUSEUM**

Paso Robles, CA

## 2. CODE RINGING DATA FOR VARIOUS TYPES OF OFFICES

2.01 In the data following, "L" represents a long ring; "M," a medium ring; "S," a short ring and "—" a pause. "T" indicates tip side ringing and "R" ring side ringing.

### CX10, CX30, CX60, CX100, CX200 and CX1000 Offices

2.02 The station number final digit determines the individual code and, in the case of divided code ringing, whether the ringing is tip or ring side as indicated below. When both the first and second set of codes are used, the first digit of the station number determines which set of codes is rung.

| <u>Station Number<br/>Final Digit</u> | <u>First Set<br/>of Codes</u> | <u>Second Set<br/>of Codes</u> |
|---------------------------------------|-------------------------------|--------------------------------|
| 1                                     | 1L (R)                        | 1S, 1L (R)                     |
| 2                                     | 2S (T)                        | 3S (T)                         |
| 3                                     | 4S (R)                        | 5S (R)                         |
| 4                                     | 2L (T)                        | 1S, 2L (T)                     |
| 5                                     | 2L, 1S (R)                    | 1S, 2L, 1S (R)                 |
| 6                                     | 2S, 1L (T)                    | 3S, 1L (T)                     |
| 7                                     | 2S, 1L, 1S (R)                | 3S, 1L, 1S (R)                 |
| 8                                     | 1L, 1S (T)                    | 1S, 1L, 1S (T)                 |
| 9                                     | 1L, 2S (R)                    | 1S, 1L, 2S (R)                 |
| 0                                     | 1L, 3S (T)                    | 1S, 1L, 3S (T)                 |

### 32A44 Offices

2.03 Ringing codes of these offices furnish ring side ringing only and two terminals per line are therefore used for divided ringing party lines. The station number final digit determines the individual code as indicated below. When both the first and second set of codes are used, the first digit of the station number determines which set of codes is rung. The second set of codes is not used with divided ringing.

| <u>Station Number<br/>Final Digit</u> | <u>First Set<br/>of Codes</u> | <u>Second Set<br/>of Codes</u> |
|---------------------------------------|-------------------------------|--------------------------------|
| 1                                     | 1L                            | 2S—3S                          |
| 2                                     | 2S                            | 2S—4S                          |
| 3                                     | 3S                            | 3S—1S                          |
| 4                                     | 4S                            | 3S—2S                          |
| 5                                     | 1S—1S                         | 3S—3S                          |
| 6                                     | 1S—2S                         | 3S—4S                          |
| 7                                     | 1S—3S                         | 4S—1S                          |
| 8                                     | 1S—4S                         | 4S—2S                          |
| 9                                     | 2S—1S                         | 4S—3S                          |
| 0                                     | 2S—2S                         | 4S—4S                          |

### 375 Offices

2.04 The station number final digit determines the individual code. The first digit of the station number determines tip or ring side ringing as well as whether the first or second set of codes is rung, if both sets are used.

| <u>Station Number<br/>First Digit</u> | <u>Code and Tip or<br/>Ring Side Ringing</u> |
|---------------------------------------|--|
| 2                                     | First set on ring                            |
| 3                                     | First set on tip                             |
| 4                                     | Second set on ring                           |
| 5                                     | First set on ring                            |
| 6                                     | First set on tip                             |

| <u>Station Number<br/>Final Digit</u> | <u>First Set<br/>of Codes</u> | <u>Second Set<br/>of Codes</u> |
|---------------------------------------|-------------------------------|--------------------------------|
| 1                                     | 1L                            | 2S—1S                          |
| 2                                     | 1L, 1S                        | 2S—2S                          |
| 3                                     | 1L, 2S                        | 2S—3S                          |
| 4                                     | 1L, 3S                        | 2S—4S                          |
| 5                                     | 1L, 4S                        | 3S—4S                          |
| 6                                     | 2L                            | 4S—1S                          |
| 7                                     | 1S, 1L                        | 3S—1S                          |
| 8                                     | 2S, 1L                        | 3S—2S                          |
| 9                                     | 3S, 1L                        | 3S—3S                          |
| 0                                     | 4S, 1L                        | 4S—2S                          |

### 385 and 386 Offices

2.05 The station number final digit determines the individual code and whether the ringing is tip or ring side. When both the first and second set of codes are used, the first digit of the station number determines which set is rung, 1 to 6 giving the first set and 7, the second set.

| <u>Station Number<br/>Final Digit</u> | <u>First Set<br/>of Codes</u> | <u>Second Set<br/>of Codes</u> |
|---------------------------------------|-------------------------------|--------------------------------|
| 1                                     | 1L (R)                        | 2S—1S (R)                      |
| 2                                     | 1L, 1S (R)                    | 2S—2S (R)                      |
| 3                                     | 1L, 2S (R)                    | 2S—3S (R)                      |
| 4                                     | 1L, 3S (R)                    | 2S—4S (R)                      |
| 5                                     | 1L, 4S (R)                    | 3S—4S (R)                      |
| 6                                     | 2L (T)                        | 4S—1S (T)                      |
| 7                                     | 1S, 1L (T)                    | 3S—1S (T)                      |
| 8                                     | 2S, 1L (T)                    | 3S—2S (T)                      |
| 9                                     | 3S, 1L (T)                    | 3S—3S (T)                      |
| 0                                     | 4S, 1L (T)                    | 4S—2S (T)                      |

C63.269

Page 3

LINE AND  
RINGER  
CONNECTIONS  
MAIN AND  
EXTENSION  
STATIONS

**32A32 Offices**

2.06 A ringing code having five different ringing combinations is used with the station number final digit determining the individual code and whether the ringing is tip or ring side. There are two different arrangements, (a) and (b), of the way the code is rung as indicated below. Either one may be used at any one office.

| <u>Station Number<br/>Final Digit</u> | <u>Arrangement<br/>(a)</u> | <u>Arrangement<br/>(b)</u> |
|---------------------------------------|----------------------------|----------------------------|
| 1                                     | 1L (T)                     | 1L (R)                     |
| 2                                     | 2S (R)                     | 2S (R)                     |
| 3                                     | 3S (T)                     | 3S (R)                     |
| 4                                     | 4S (R)                     | 4S (R)                     |
| 5                                     | 1L, 1S (T)                 | 1L, 1S (R)                 |
| 6                                     | 1L (R)                     | 1L (T)                     |
| 7                                     | 2S (T)                     | 2S (T)                     |
| 8                                     | 3S (R)                     | 3S (T)                     |
| 9                                     | 4S (T)                     | 4S (T)                     |
| 0                                     | 1L, 1S (R)                 | 1L, 1S (T)                 |

**36A1 Offices**

2.07 The individual code rung and tip or ring side ringing is determined by the station number final digit as shown in 2.06 under Arrangement (a) for the 32A32 offices.

**36A3 Offices**

2.08 The individual code rung and tip or ring side ringing is determined by the station number final digit as shown in 2.06 under Arrangement (b) for the 32A32 offices.

**35E97 Offices**

2.09 A code having either five or ten different ringing combinations may be provided. The station number final digit determines the individual code and whether ringing is tip or ring side. **In the case of ten code ringing, if more than ten parties are on the line, the tip and ring connections for these additional parties are reversed at the office and for these parties 1 to 5 gives tip side and 6 to 0 ring side ringing.**

| <u>Station Number<br/>Final Digit</u> | <u>Five Code</u> | <u>Ten Code</u> |
|---------------------------------------|------------------|-----------------|
| 1                                     | 1L (R)           | 1L (R)          |
| 2                                     | 2S (R)           | 2S (R)          |
| 3                                     | 3S (R)           | 3S (R)          |
| 4                                     | 4S (R)           | 4S (R)          |
| 5                                     | 1L, 1S (R)       | 1L, 1S (R)      |
| 6                                     | 1L (T)           | 1L, 2S (T)      |
| 7                                     | 2S (T)           | 2L (T)          |
| 8                                     | 3S (T)           | 1S, 1L (T)      |
| 9                                     | 4S (T)           | 1S, 2L (T)      |
| 0                                     | 1L, 1S (T)       | 2S, 1L (T)      |

**Manual, Step-by-Step No. 1 and 350 Offices** ←

2.10 These offices may use any one of four different codes, known as the "Pre-A5", the "A-5", the "C" and the "D" codes. Offices having terminal per line connection use either the "Pre-A5" or the "A5" code and the station number final digit determines the individual code and whether the ringing is tip or ring side.

| <u>Station Number<br/>Final Digit</u> | <u>Pre- A5<br/>Code</u> | <u>A5<br/>Code</u> |
|---------------------------------------|-------------------------|--------------------|
| 1                                     | 1L (R)                  | 1L (R)             |
| 2                                     | 1L (T)                  | 1L (T)             |
| 3                                     | 2S (R)                  | 2S (R)             |
| 4                                     | 2S (T)                  | 2S (T)             |
| 5                                     | 3S (R)                  | 3S (R)             |
| 6                                     | 3S (T)                  | 3S (T)             |
| 7                                     | 4S (R)                  | 1L, 1S (R)         |
| 8                                     | 4S (T)                  | 1L, 1S (T)         |
| 9                                     | 1L, 1S (R)              | 4S (R)             |
| 0                                     | 1L, 1S (T)              | 4S (T)             |

2.11 Offices having terminal per station connections use the "C" or "D" code. At these offices, the individual code rung and tip or ring side ringing is not determined by the digits of the station number. Therefore at stations connected to such offices, information as to these points should be determined from the assignment card.

| <u>"C" Code</u> | <u>"D" Code</u> |
|-----------------|-----------------|
| 2M              | 1L              |
| 3S              | 2L              |
| 4S              | 1L, 1S          |
| 1L, 1S          | 1L, 2S          |
| 1L, 2S          | 1L, 1S, 1L      |

**355 Offices**

2.12 These offices may use any one of three different codes, known as the "A5", "A10" and "B" code. In offices having terminal per line connection and using the "A5" or "A10" codes, the final digit of the station number determines the individual code and whether ringing is tip or ring side.

| <u>Station Number<br/>Final Digit</u> | <u>A5<br/>Code</u> | <u>A10<br/>Code</u> |
|---------------------------------------|--------------------|---------------------|
| 1                                     | 1L (R)             | 1L (R)              |
| 2                                     | 1L (T)             | 2S (T)              |
| 3                                     | 2S (R)             | 3S (R)              |
| 4                                     | 2S (T)             | 1L, 1S (T)          |
| 5                                     | 3S (R)             | 4S (R)              |
| 6                                     | 3S (T)             | 1L, 2S (T)          |
| 7                                     | 1L, 1S (R)         | 1S, 1L (R)          |
| 8                                     | 1L, 1S (T)         | 2L (T)              |
| 9                                     | 4S (R)             | 1S, 1L, 1S (R)      |
| 0                                     | 4S (T)             | 2S, 1L (T)          |

2.13 In offices having terminal per station connection and using the "A5" code, the individual code rung and tip or ring side ringing is not determined by the digits of the station number. Therefore at stations connected to such offices, information as to these points should be determined from the assignment card.

2.14 In offices using the "B" code, the station number final digit determines the individual code and whether ringing is tip or ring side. When both the first and second set of codes are used, the third digit from the last of the station number determines which set of codes is rung. In case of ten code ringing, if more than ten parties are on the line, the tip and ring connections for these additional parties are reversed at the office and for these parties, 1, 3, 5, 7 and 9 give tip side and 2, 4, 6, 8 and 0 ring side ringing.

| <u>Station Number<br/>Final Digit</u> | <u>First Set<br/>of Codes</u> | <u>Second Set<br/>of Codes</u> |
|---------------------------------------|-------------------------------|--------------------------------|
| 1                                     | 1L (R)                        | 1S, 1L (R)                     |
| 2                                     | 2S (T)                        | 3S (T)                         |
| 3                                     | 4S (R)                        | 5S (R)                         |
| 4                                     | 2L (T)                        | 1S, 2L (T)                     |
| 5                                     | 2L, 1S (R)                    | 1S, 2L, 1S (R)                 |
| 6                                     | 2S, 1L (T)                    | 3S, 1L (T)                     |
| 7                                     | 2S, 1L, 1S (R)                | 3S, 1L, 1S (R)                 |
| 8                                     | 1L, 1S (T)                    | 1S, 1L, 1S (T)                 |
| 9                                     | 1L, 2S (R)                    | 1S, 1L, 2S (R)                 |
| 0                                     | 1L, 3S (T)                    | 1S, 1L, 3S (T)                 |

### 360 Offices

2.15 The station number final digit determines the individual code and whether ringing is tip side or ring side.

| <u>Station Number<br/>Final Digit</u> | <u>Code</u> |
|---------------------------------------|-------------|
| 1                                     | 1L (R)      |
| 2                                     | 1L (T)      |
| 3                                     | 2S (R)      |
| 4                                     | 2S (T)      |
| 5                                     | 3S (R)      |
| 6                                     | 3S (T)      |
| 7                                     | 4S (R)      |
| 8                                     | 4S (T)      |
| 9                                     | 1L, 1S (R)  |
| 0                                     | 1L, 1S (T)  |

### 370 Offices

2.16 The station number final digit determines the individual code and whether ringing is tip side or ring side.

| <u>Station Number<br/>Final Digit</u> | <u>Code</u> |
|---------------------------------------|-------------|
| 1                                     | 2M (R)      |
| 2                                     | 2M (T)      |
| 3                                     | 3S (R)      |
| 4                                     | 3S (T)      |
| 5                                     | 4S (R)      |
| 6                                     | 4S (T)      |
| 7                                     | 1L, 1S (R)  |
| 8                                     | 1L, 1S (T)  |
| 9                                     | 1L, 2S (R)  |
| 0                                     | 1L, 2S (T)  |

## 3. CONNECTIONS

3.01 Use only high impedance ringing bridges at ten and twenty-party bridged or divided code ringing stations. The station sets to be used are those specified for divided code ringing stations in the sections listing station sets by classes of service.

3.02 The maximum number of ringing bridges per line and the conductor loop resistance ranges (in the case of ground return lines, the conductor resistance) for lines served by the various types of offices are given in Table 1. The limitations as to loop resistance, except in the case of the 355 type 20 code office, do not contemplate the use of long line circuits.

If such circuits are used the loop resistance may be increased. These loop ranges are the usually accepted values for the type of office indicated when central office maintenance procedures are followed and battery voltages are maintained at or above the recommended minimum.

**TABLE 1**  
**MAXIMUM NUMBER OF RINGING BRIDGES AND LOOP RESISTANCE FOR DIAL OFFICE INDICATED**

| Type of Office   | No. of Ringing Bridges<br>Each Side<br>of Line |              | Conductor<br>Loop Resistance<br>in Ohms |
|------------------|--|--------------|---|
|                  | Bridged  | or to Ground |   |
| All CX, 32A44    | 10   | 10           | 885                                     |
| 375, 385, 386    |  |              |   |
| 32A32, 36A1,     | 5  | 5            | 885                                     |
| 36A3, 35E97      |  |              |   |
| 350 or SXS No. 1 | 5  | 5            | 635, 735 or 885                         |
| 355—5 Code       | 7  | 7            | 885                                     |
| (See note 1)     |  |              |   |
| 355—10 Code      | 10   | 10           | 885                                     |
| 355—20 Code      | 20   | 10           | 635                                     |
| (See note 2)     |  |              |   |
| 360              | 5  | 5            | 635                                     |
| 370              | 5  | 5            | 635                                     |

Note 1: The number of allowable ringing bridges permits the use of two extensions with ringers per line for bridged and two per side for divided code ringing on lines having the maximum number of main stations.

Note 2: Auxiliary line circuits are required on ground return lines. If the resistance of the conductor to the station furthest away from the office is 750 ohms or less, 20 ringing bridges may be connected to the line. The allowable number of bridges is progressively reduced as the conductor resistance to the furthest station increases, until at 1600 ohms, 10 bridges may be used.

3.03 Extension stations with ringers or extension ringers may be provided so long as the limits given in Table 1 are not exceeded. If more than one loud ringing bell must be connected across the line or on a given side, each 392 type subscriber set (loud ringing bell) added after the first shall be considered as the equivalent of two ringing bridges, but each



592 type may be considered as one bridge. In this connection, limits of unbalance as given in Section C63.251 must be given consideration.

3.04 For extension stations without ringers, see Section C63.261.

3.05 The connections shown in Figs. 1, 2 and 3 are for anti-sidetone subscriber sets. Similar line and ringer connections are used with sidetone subscriber sets.

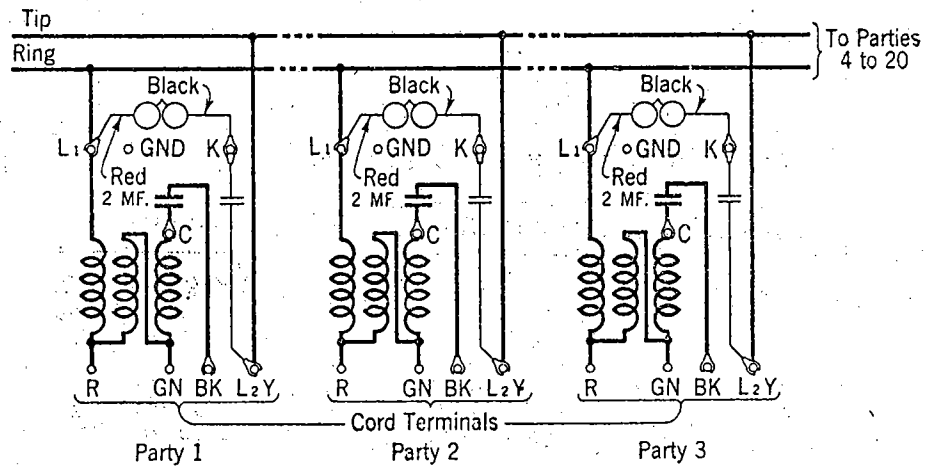

**Fig. 1—Bridged Ringing Anti-Sidetone Stations—High Impedance Ringers**

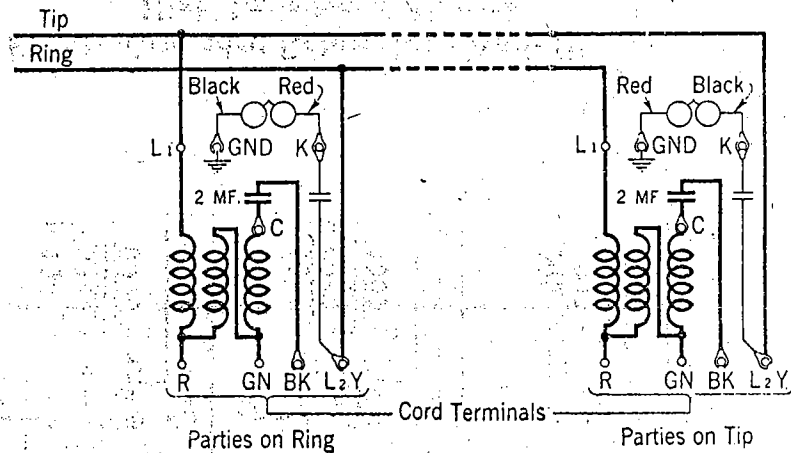

**Fig. 2—Divided Code Ringing Anti-Sidetone Stations—High Impedance Ringers**

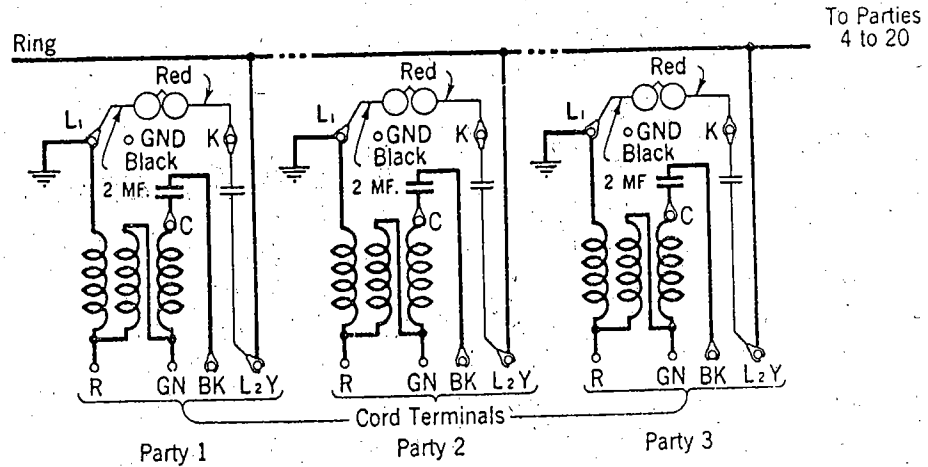

**Fig. 3—Grounded Return Line Anti-Sidetone Stations—  
High Impedance Ringers**

3.06 In general the maximum external circuit for grounded lines is as follows:

|   |   |  |
|---|---|--|
| <p><b>Automatic<br/>Electric Co.<br/>Offices</b><br/>375, 385, 386,<br/>32A32, 32A44,<br/>36A1 and 36A3</p> | <p><b>North Electric<br/>Co. Offices</b><br/>All CX Types</p> | <p><b>SXS No. 1</b><br/>350 and<br/>355A</p> |
| <p>500 ohms</p>   | <p>1100 ohms</p>  | <p>1400-2000 ohms</p>                        |

The number of ringers and codes is the same as for metallic circuits.