

32 KEYBOARD
 LUBRICATION

CONTENTS	PAGE
1. GENERAL	1
2. BASIC UNIT	2
Codebar mechanism	5
Contact block	4
HERE IS, BREAK, and REPT keylevers	3
Keyboard	2
Keylevers	3
Latchlever hooks	4
LTRS-FIGS detent	4
Reset bail	5
Spacebar	3
Universal lever	5
3. OPTIONAL FEATURE	6
Locking mechanism	6

LUBRICATION INTERVAL
 (Based on 5-day Week)

Daily Operation of Keyboard			
Speed (wpm)	0-8 hrs	8-16 hrs	16-24 hrs
60	39 wks	26 wks	13 wks
66	39 wks	26 wks	13 wks
75	39 wks	26 wks	13 wks
100	26 wks	13 wks	6 wks

Note 1: Reduce lubricating intervals 15% for a 6-day week, and 30% for a 7-day week.

Note 2: Units with serial nos. below 144,000, reduce lubricating intervals 33%. Units with serial nos. above 144,000, use above chart.

1.05 The textual instructions that accompany each line drawing consist of abbreviated directions, specific lubrication points, and parts affected. The meanings of the abbreviated directions (symbols) are given below:

<u>Symbol</u>	<u>Meaning</u>
D	Keep dry -- no lubricant permitted.
O	Oil (KS7470)
G	Apply thin coat of grease (KS7471).

1.06 References to left, right, front, or rear, etc, consider the keyboard to be viewed from a position where the spacebar faces up and the contact mechanism is located to the viewer's right.

CAUTION: DO NOT USE ALCOHOL, MINERAL SPIRITS, OR OTHER SOLVENTS TO CLEAN PLASTIC PARTS OR PARTS WITH PROTECTIVE DECORATIVE FINISHES. NORMALLY, A SOFT, DRY CLOTH SHOULD BE USED TO REMOVE DUST, OIL, GREASE, OR OTHERWISE CLEAN PARTS OR SUBASSEMBLIES. IF NECESSARY, A SOFT CLOTH DAMPENED WITH SOAP OR MILD DETERGENT MAY BE USED. AFTERWARDS,

1. GENERAL

1.01 This section provides lubrication requirements for the 32 keyboard. It is reissued to include engineering changes. Marginal arrows indicate changes.

1.02 The general lubrication areas are illustrated by photographs. The specific points to receive lubricant are indicated on line drawings with appropriate textual instructions. The line drawings and textual instructions follow a photograph and are keyed to the photograph by paragraph numbers.

1.03 Thoroughly lubricate the keyboard, but avoid overlubrication that might permit the lubricant to drip or be thrown onto adjacent parts.

1.04 Lubricate keyboard before placing it in storage, or before placing it in service if it had been stored six months or longer. Thereafter, relubricate keyboard at the following intervals:

RINSE PART OR SUBASSEMBLY WITH A SOFT, DAMP CLOTH AND BUFF WITH A SOFT, DRY CLOTH.

1.07 Tools and materials needed for teletypewriter lubrication are listed in Section 570-005-800TC.

1.08 Disassembly and reassembly instructions are given in Section 574-171-702TC.

CAUTION: REMOVE ALL ELECTRICAL POWER FROM UNIT BEFORE LUBRICATION OR DISASSEMBLY.

2. BASIC UNIT

2.01 Keyboard

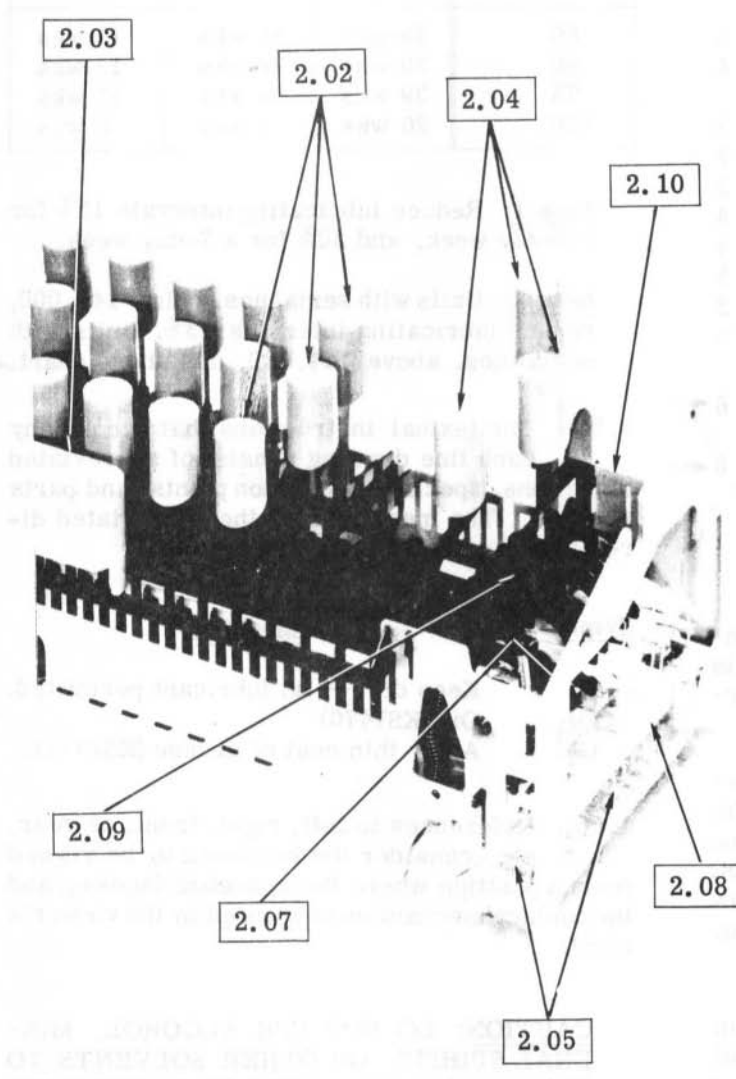

(Right Front View,
Keyboard Cover Removed)

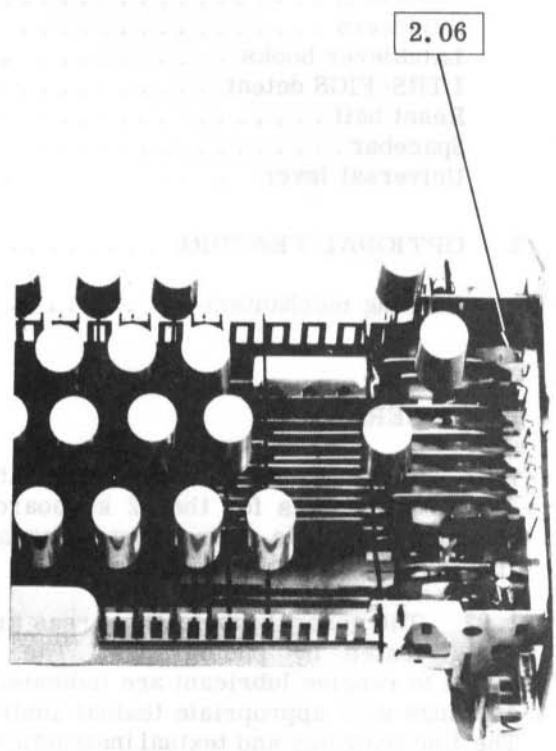

(Front View,
4-Row 5-Level Keyboard)

2.02 Keylevers

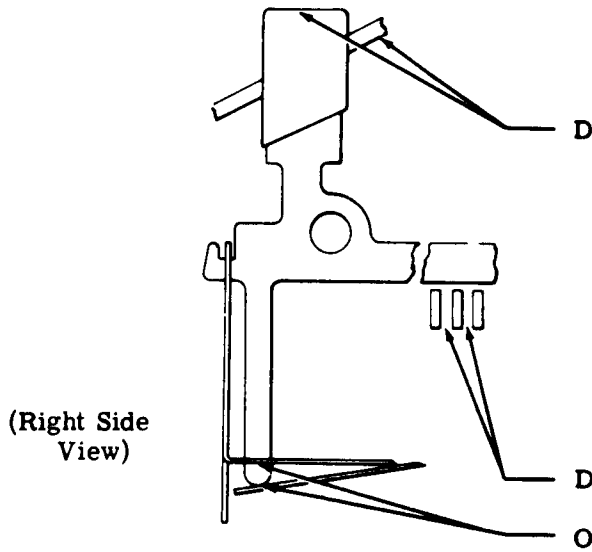

- D Top Surface Keytops and Keyboard Cover
- D Areas Between Bars Codebars
- O Contact Surface Keylever Springs

2.03 Spacebar

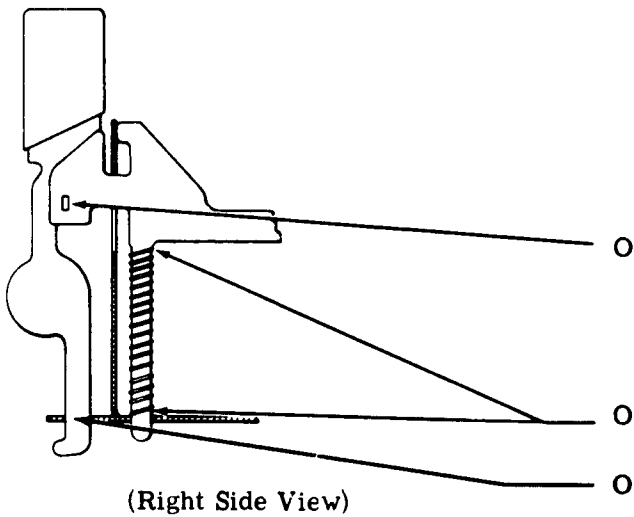

- O Contact Surfaces (5) Space Lever
- O Seat (Each End) Springs (2)
- O Sliding Surfaces Space Lever

2.04 HERE IS, BREAK, and REPT Keylevers

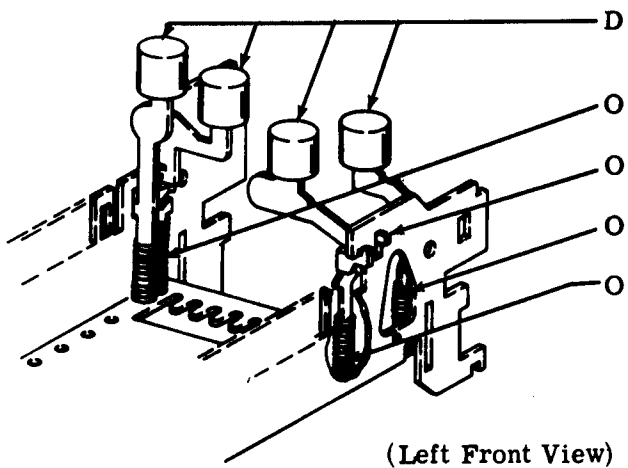

- D Top Surface Keytops
- O Seat (Each End) Springs
- O Contact Surfaces Keylevers
- O Seat (Each End) Spring
- O Seat (Each End) Spring

2.05 Contact Block

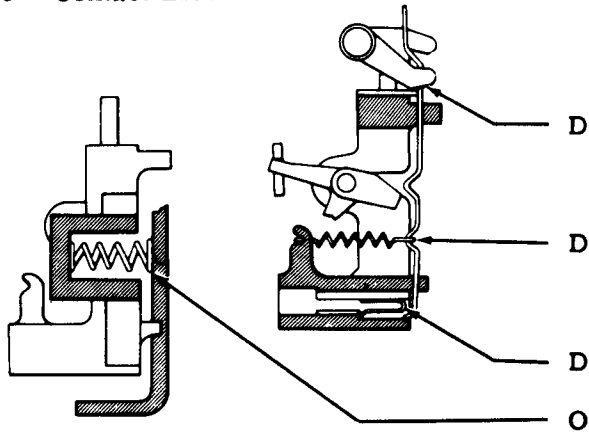

(Front Views)

D	Contact Surface	Contact Wires
D	Springs	Contact Wires
D	Contact Surface	Contact Wires
O	Seat	Springs (2)

CAUTION: DO NOT CLEAN THE KEYBOARD CONTACT BLOCK WITH ALCOHOL, MINERAL SPIRITS, OR OTHER SOLVENTS.

2.06 LTRS-FIGS Detent

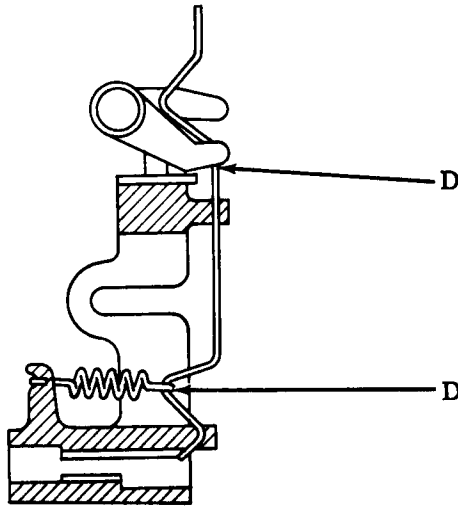

(Front View)

Note: Requirement is for 4-row 5-level keyboards only.

D	Contact Surface	Detent
D	Spring	Detent

2.07 Latchlever Hooks

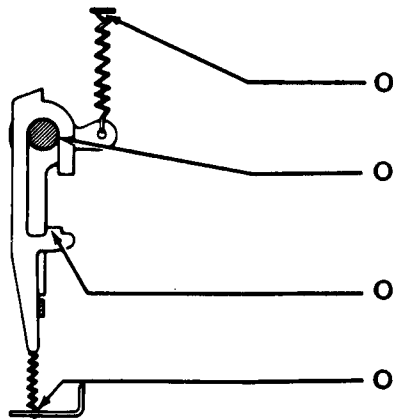

(Front View)

O	Hooks (Each End)	Latchlever Spring
O	Pivot	Latchlever and Nonrepeat Lever
O	Contact Surface	Latchlever
O	Hooks (Each End)	Nonrepeat Spring

2.08 Reset Bail

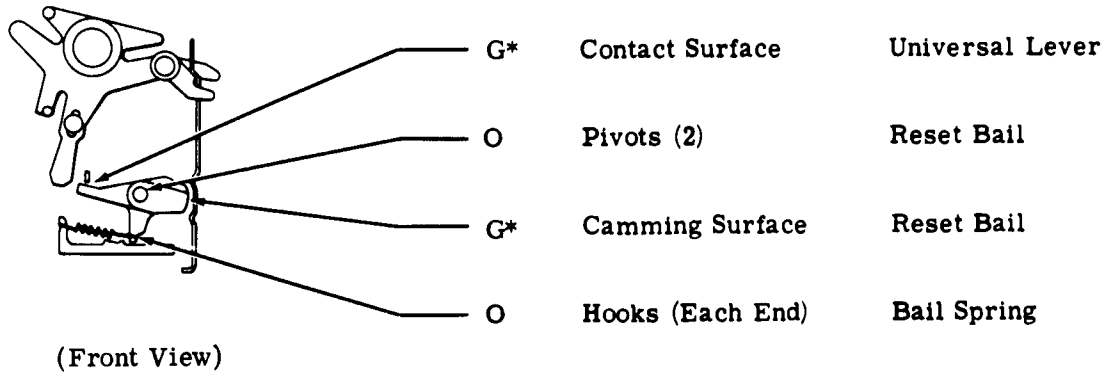

*At 1500 hour lubrication intervals, apply a coat of thoroughly mixed 50 percent KS7470 oil and 50 percent KS7471 grease. ←

2.09 Codebar Mechanism

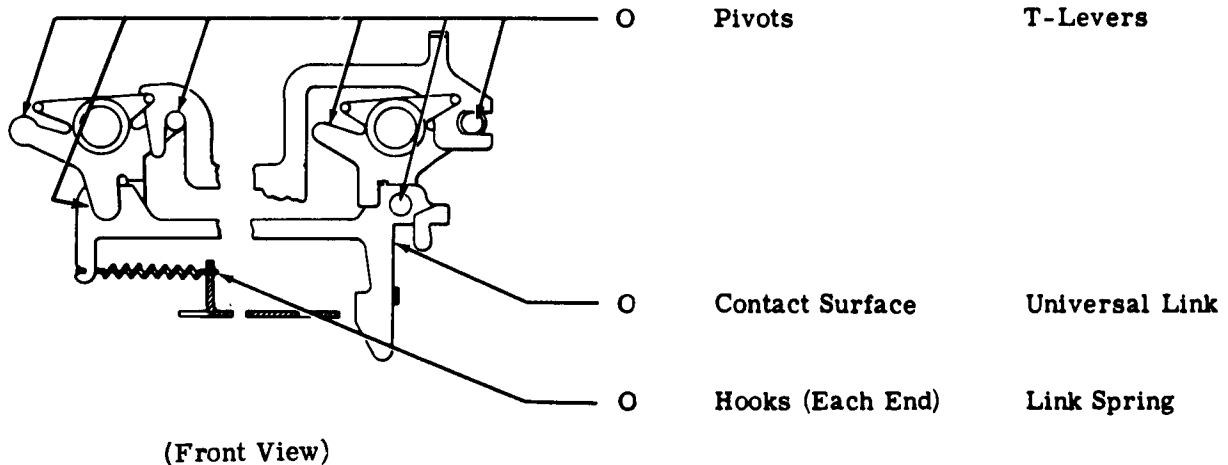

2.10 Universal Lever

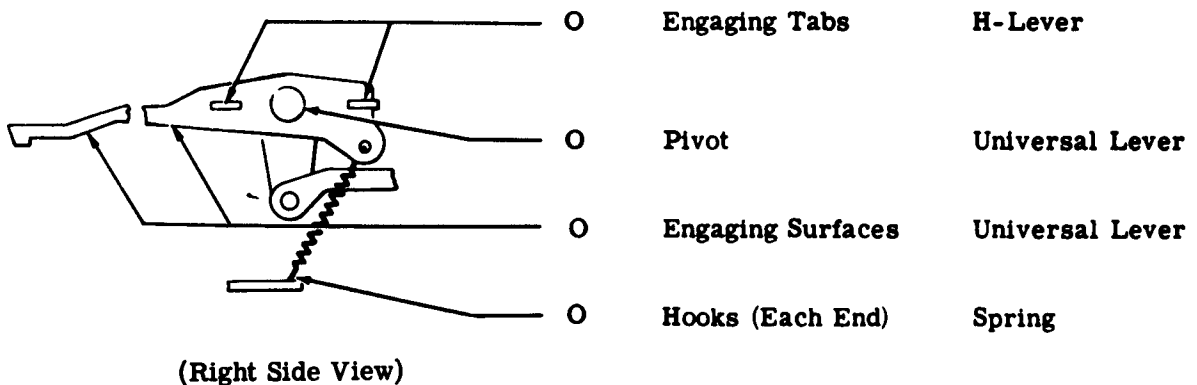

3. OPTIONAL FEATURE

3.01 Locking Mechanism

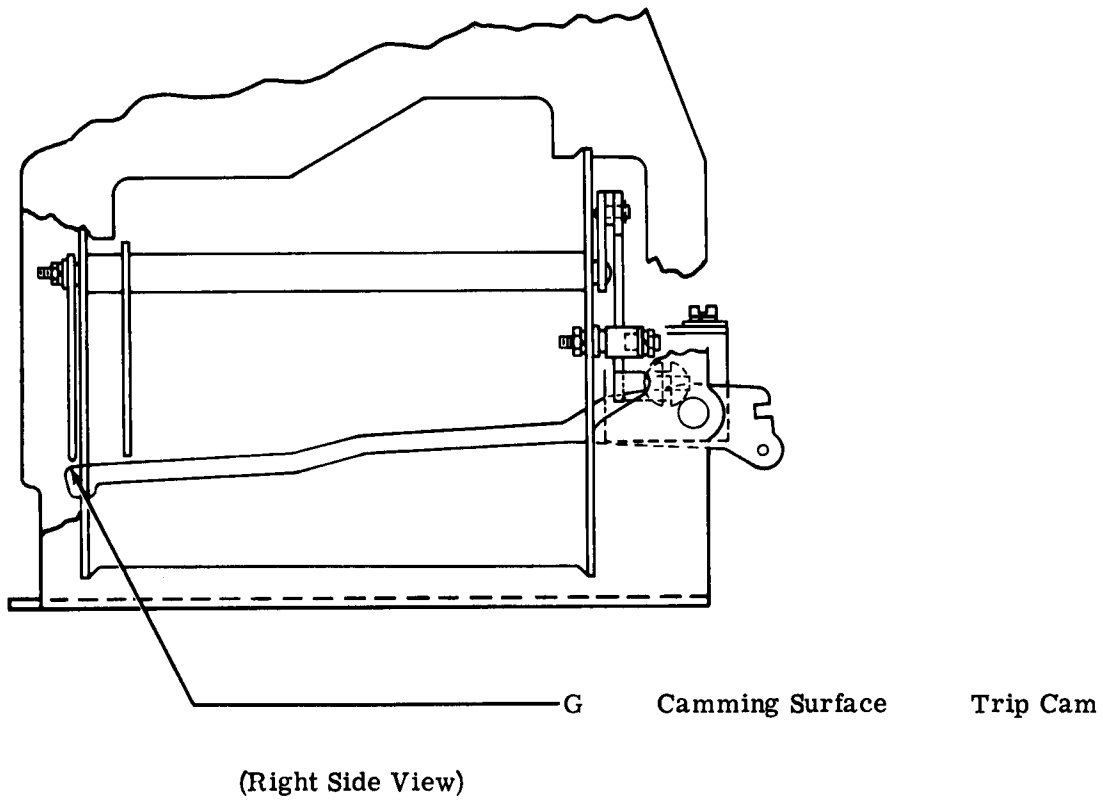
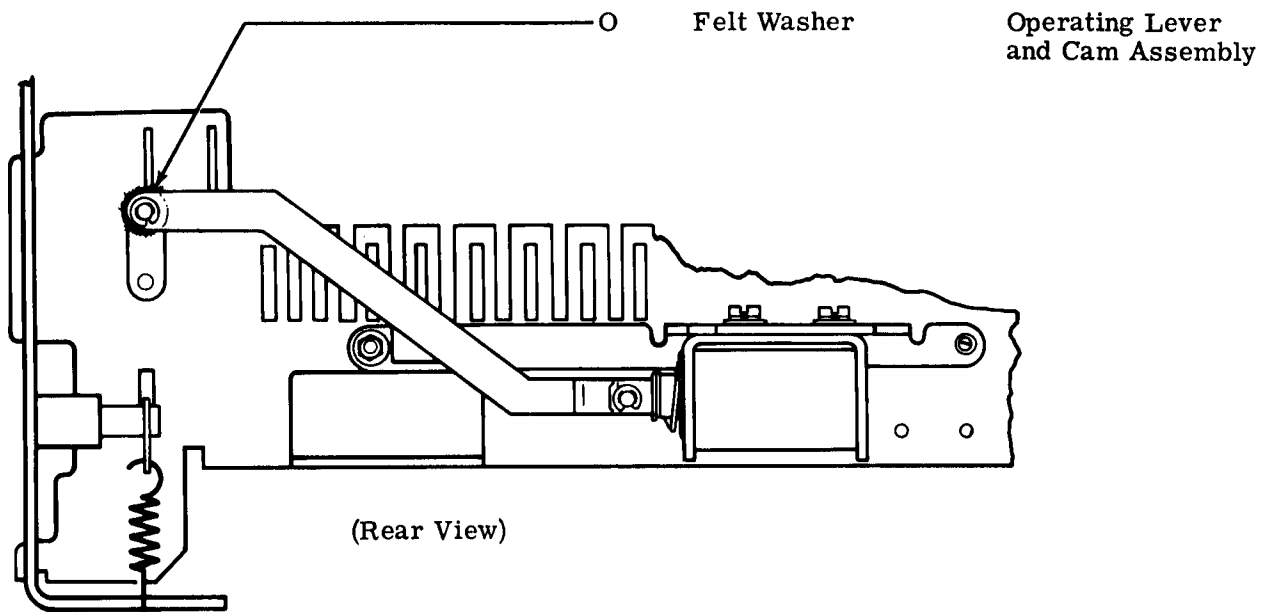

32 KEYBOARD

DISASSEMBLY AND REASSEMBLY

CONTENTS	PAGE
1. GENERAL	1
2. DISASSEMBLY AND REASSEMBLY . .	1
KEYLEVER COVER	1
KEYLEVER	2
SPACEBAR MECHANISM	3
CODEBAR	4
KEYBOARD CONTACT MECHANISM	4
T-LEVER SHAFTS	4
LOCKING MECHANISM	4 ←

1. GENERAL

1.01 This section contains disassembly and reassembly information for 32 keyboards. It is reissued to include information for the keyboard locking mechanism. Marginal arrows indicate changes. ←

1.02 References to left, right, front, rear, etc, consider the keyboard to be viewed from a position where the spacebar faces up and the contact mechanism is located to the viewer's right.

1.03 Disassembly, as outlined in this section, covers the procedure for removing the principle subassemblies which make up the unit. If further disassembly is required, refer to Section 574-171-800TC which shows detailed arrangements of parts. Where it will help in determining their location, the numbers of the parts are given in the instructions. ←

CAUTION: BEFORE BEGINNING DISASSEMBLY, REMOVE CONNECTORS FROM EXTERNAL RECEPTACLES (POWER SOURCE, DATA SET, ETC).

1.04 When self-tapping screws are used to mount mechanisms onto castings, do not remove the self-tapping screws. Merely loosen them enough to remove the mechanisms unless specifically instructed otherwise.

1.05 Retaining rings are made of spring steel and have a tendency to release suddenly. To avoid loss of these rings when removing them, proceed as follows:

- (a) Hold retaining ring to prevent its rotating.
- (b) Place blade of screwdriver in one of ring's slots and rotate screwdriver to increase diameter.
- (c) Ring will come off easily in fingers without flying.

1.06 All tools used to remove the mechanisms referred to in this section can be found in the 570-005-800TC standard tool section.

1.07 All damaged, worn, or distorted parts should be replaced if encountered in the disassembly and reassembly procedures.

2. DISASSEMBLY AND REASSEMBLY

Note: For information concerning the proper procedure to remove the keyboard assemblies from the set, refer to Section 574-160-702TC. ←

KEYBOARD COVER

2.01 To remove the keyboard cover (Figure 2), proceed as follows.

(a) Remove TP119652 retaining ring and TP41663 flat washer from the left side of the keyboard cover, and rotate the left side bracket away. ←

(b) Hold the right side bracket firmly in place against the two TP180031 compression springs of keyboard contact mechanism, and remove the TP119652 retaining ring and TP41663 flat washer from the right side of the keyboard cover. ←

(c) Continue to hold the right side bracket firmly in place, and disengage the keyboard cover from the right side bracket by moving it up and to the left. Lift the keyboard cover off the keys.

Note: With the keyboard cover removed, the right side bracket may be pushed unexpectedly from its assembled position, due to the spring load of two compression springs. If this happens, certain parts may prematurely fall off. To prevent this, always keep the right side bracket firmly against the two compression springs of the keyboard contact mechanism, i e, either hold the right side bracket in place by hand or place it firmly against a fixed vertical surface.

(d) To replace the keyboard cover, reverse the procedure used to remove it.

KEYLEVER

2.02 To remove any keylever (Figure 1), proceed as follows.

- (a) Depress the front end of the TP182240, TP185766 (earlier designs), or TP186253 (late design) universal lever.
- (b) Depress keylever and disengage it from front or rear guide slot.
- (c) Lift keylever out of keyboard frame.
- (d) To replace any keylever, reverse procedure used to remove it.

Note: Certain levers have compression springs on their lower stems. Make sure that the springs are properly replaced during reassembly.

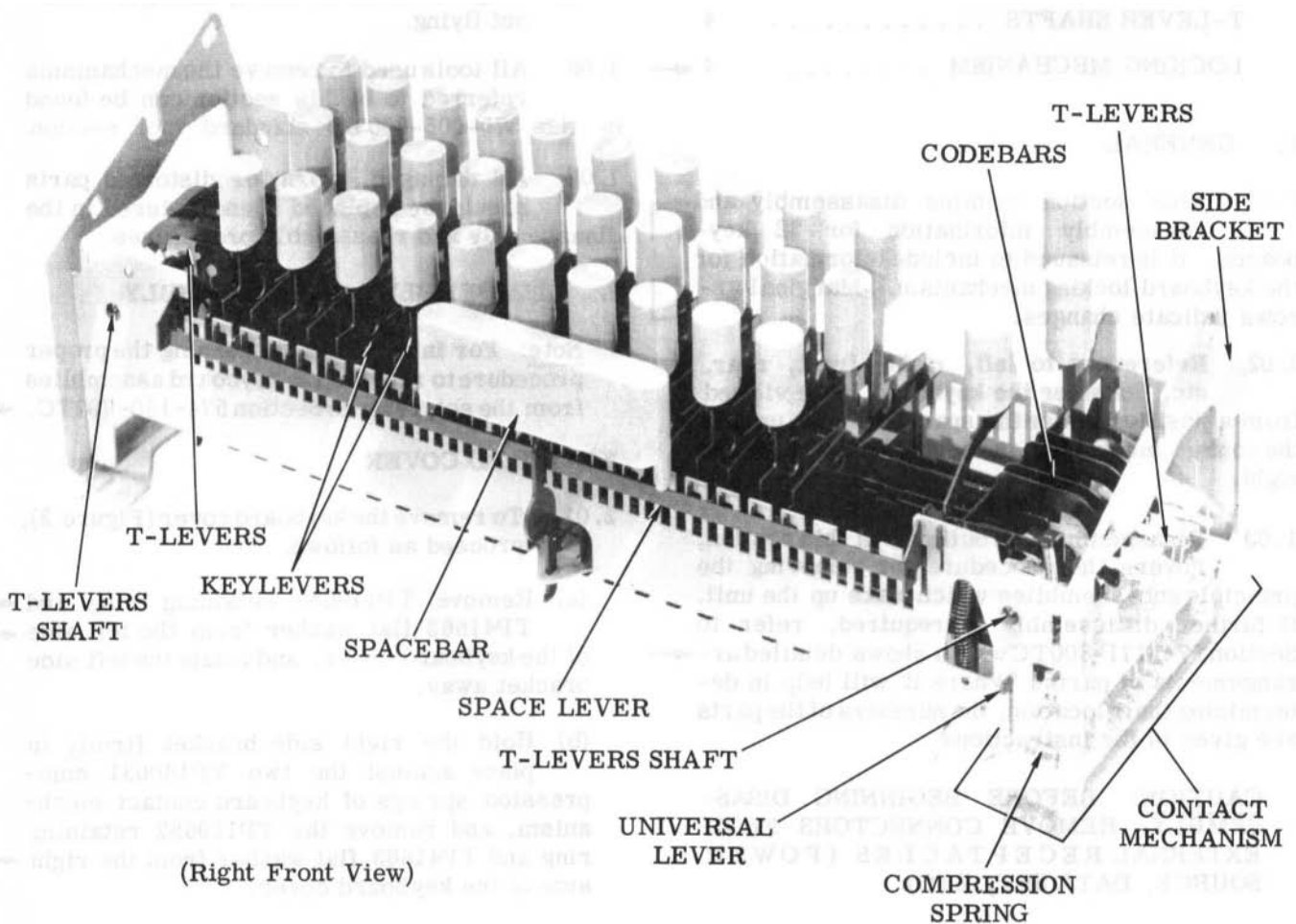

Figure 1 - Keyboard (Cover Removed)

SPACEBAR MECHANISM

2.03 To remove spacebar mechanism (Figure 1), proceed as follows.

- (a) Remove the TP180057 spacebar with the attached TP180054 keylever.
- (b) Bow the TP180056 space lever and disengage it from the two TP180055 space keylevers.

- (c) Disengage space keylevers from guide slots and remove them from frame.

Note: Careful attention should be given to the position of compression springs on keylever's lower stems so that they can be properly replaced during reassembly.

- (d) To replace spacebar, reverse procedure used to remove it.

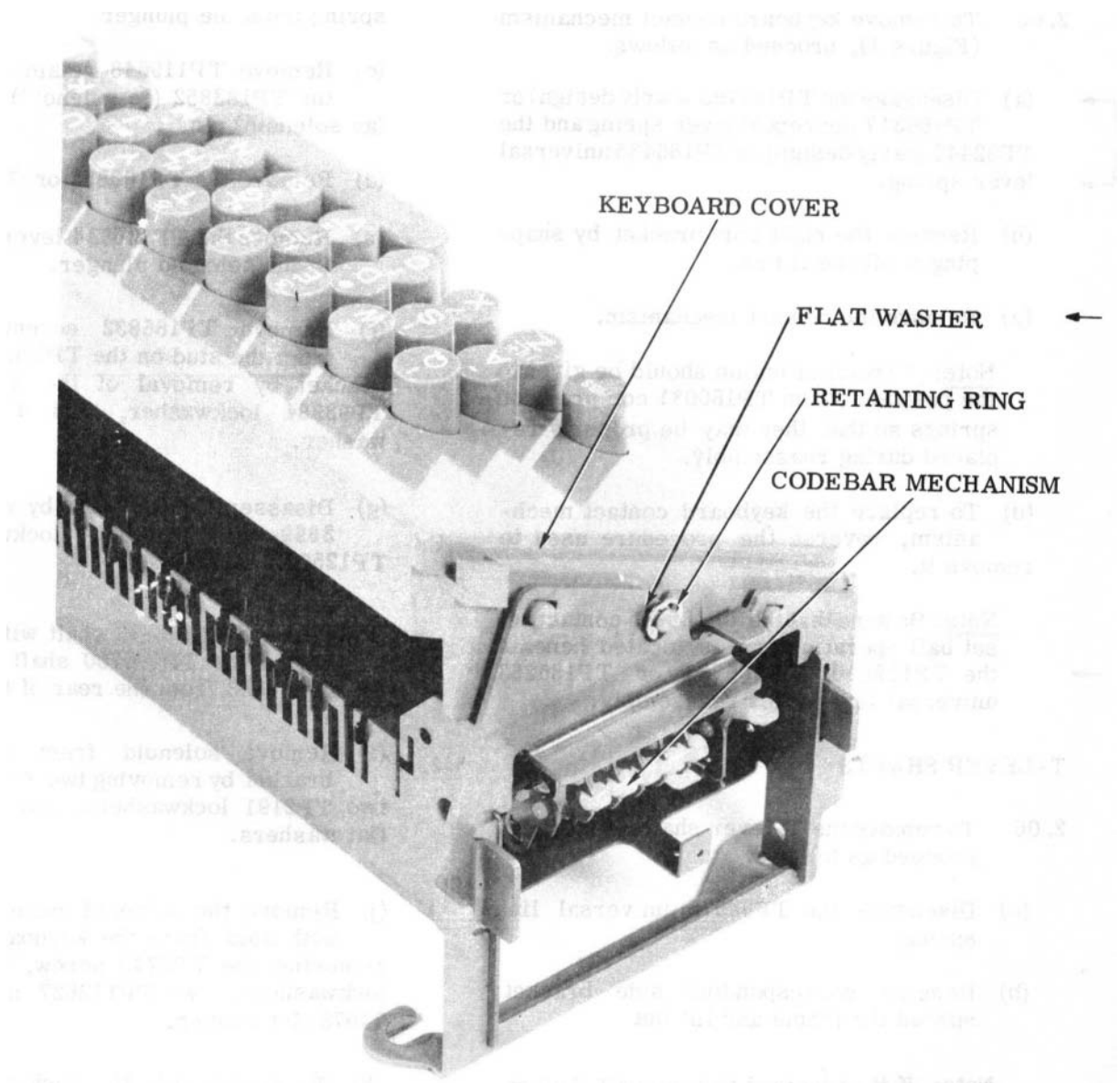

Figure 2 - Codebar Mechanism

CODEBAR

2.04 To remove any codebar (Figure 1), proceed as follows.

- (a) Remove all keylevers from typing unit.
- (b) Disengage codebars from left and right T-levers and remove them from keyboard frame.
- (c) To replace codebars, reverse procedure used to remove them.

KEYBOARD CONTACT MECHANISM

2.05 To remove keyboard contact mechanism (Figure 1), proceed as follows.

- (a) Disengage the TP185798 (early design) or TP186347 nonrepeat lever spring and the TP82442 (early design) or TP186435 universal lever spring.
- (b) Remove the right side bracket by snapping it off the frame.
- (c) Remove the contact mechanism.

Note: Careful attention should be given to the position of the TP180031 compression springs so that they may be properly replaced during reassembly.

- (d) To replace the keyboard contact mechanism, reverse the procedure used to remove it.

Note: Be sure that the TP180046 contact reset bail operating arm is located beneath the TP182240, TP185766 or TP186253 universal lever after reassembly.

T-LEVER SHAFTS

2.06 To remove the T-lever shafts (Figure 1), proceed as follows.

- (a) Disengage the TP84575 universal link spring.
- (b) Remove corresponding side bracket; spread the frame and lift out.

Note: If it is desired to remove T-levers, remove the TP119653 retaining rings and slide levers off their shafts.

- (c) To replace the T-levers shafts, reverse the procedure used to remove it.

LOCKING MECHANISM

2.07 To remove locking mechanism (Figure 3), proceed as follows:

- (a) Remove TP119648 retaining ring. Remove TP186834 lever from post. Remove TP86079 felt washer.
- (b) Remove the solenoid plunger with the TP186834 lever attached to it. On ac solenoids remove the 303037 compression spring from the plunger.
- (c) Remove TP119648 retaining ring from the TP183852 (dc solenoid) or TP321895 (ac solenoid) pin.
- (d) Remove the TP183852 or TP321895 pin.
- (e) Remove the TP186834 lever from the slot in the solenoid plunger.
- (f) Remove TP186832 eccentric bushing from the stud on the TP186830 mounting bracket by removal of the TP151880 nut, TP93984 lockwasher, and TP104807 flat washer.
- (g) Disassemble trip cam by removing TP 3599 nut, TP130664 lockwasher, and TP125011 flat washer.
- (h) Remove TP186833 shaft with lever from within the TP186700 shaft by pulling at the TP186833 from the rear of the keyboard.
- (i) Remove solenoid from its mounting bracket by removing two TP1263 screws, two TP2191 lockwashers, and two TP90790 flat washers.
- (j) Remove the solenoid mounting bracket with stud from the keyboard frame by removing the TP5740 screw, two TP93117 lockwashers, two TP112627 nuts, and TP 71073 flat washer.
- (k) To reassemble the locking mechanism reverse the procedures used to remove it.

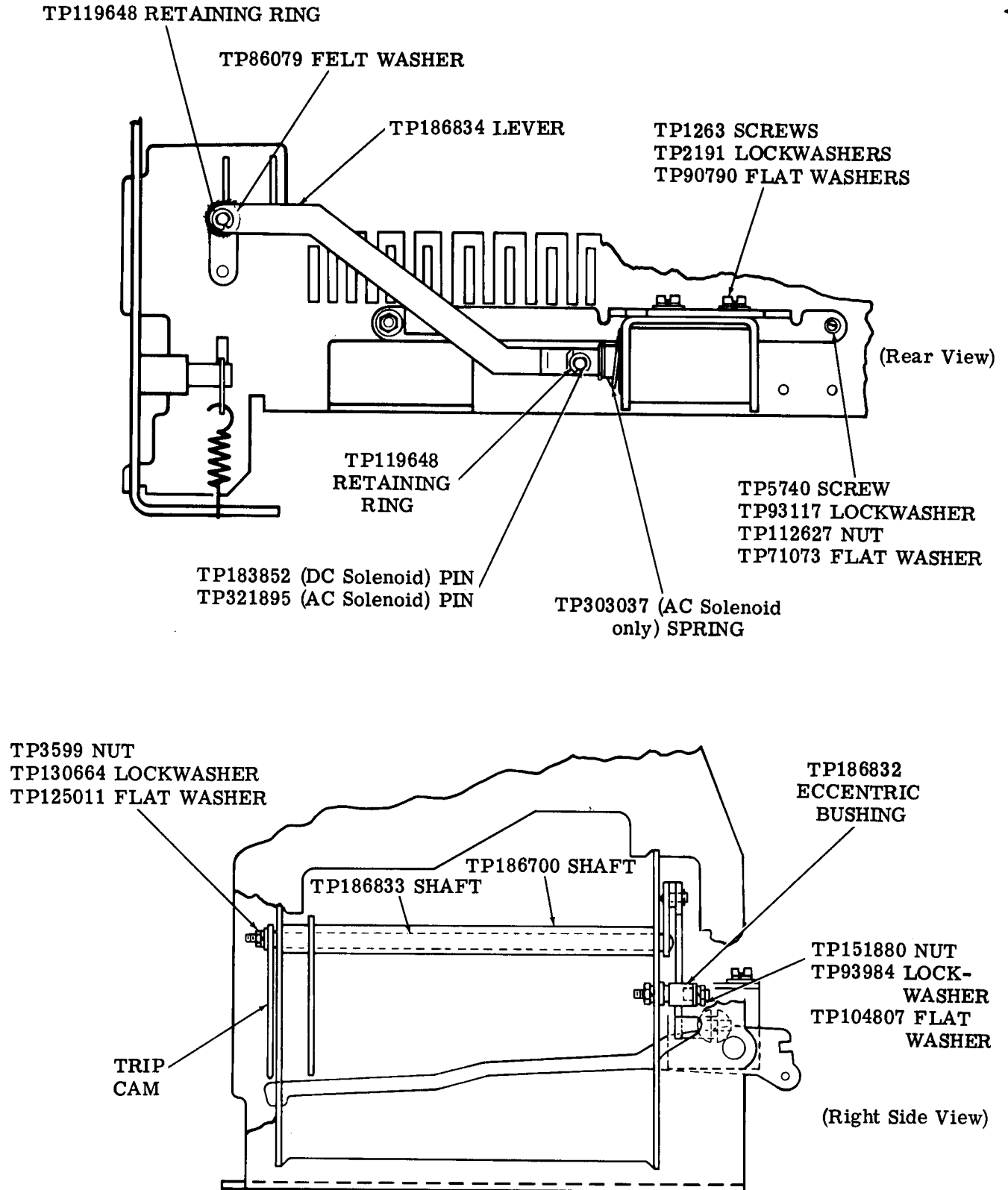

Figure 3 - Locking Mechanism

