

28 TAPE PRINTER BASE (STOCK TICKER)

DESCRIPTION, ADJUSTMENTS AND LUBRICATION

CONTENTS	PAGE
1. GENERAL	1
2. COMPONENTS	1
BASE PAN	1
BASE PLATE	1
INTERMEDIATE GEAR ASSEMBLY	1
POWER SUPPLY	4
SELECTOR MAGNET DRIVER	4
A. Function	4
B. Input Signal	4
C. Input Impedance	4
D. Input Switching Level	4
E. Switching Principle	4
F. Output Wave Shaping	4
G. Magnet Current	4
3. CIRCUIT OPERATION	4
POWER SUPPLY	4
SELECTOR MAGNET DRIVER	4
4. ADJUSTMENTS	8
Intermediate Shaft Assembly Position	8
Motor Pinion to Intermediate Gear	8
Overload Release Mechanism Spring	8
5. LUBRICATION	9
1. GENERAL	
1.01 The tape printer base provides mounting facilities for a motor, an intermediate gear assembly, the tape printer unit, power supply assembly and selector magnet driver with mounting facilities. It may be mounted on a	

table, on an associated pedestal, or in an associated projector set.

1.02 A base pan serves as a container for a base plate on which the motor intermediate gear assembly, and tape printer unit are mounted. The electrical power supply assembly and selector magnet driver are also contained in the base pan (Figs. 1 and 2).

2. COMPONENTS

BASE PAN

2.01 The base pan is a rectangular shaped stamped plate formed into a pan 14 inches long by 8-1/2 inches wide. Facilities are provided for mounting a base plate on rubber vibration mounts. The base pan is finished in matching color with its cover.

BASE PLATE

2.02 The base plate is an irregularly shaped metal plate that is mounted on the six rubber vibration mounts in the base pan. The intermediate gear assembly, motor, and tape printer unit are mounted on the base plate.

INTERMEDIATE GEAR ASSEMBLY

2.03 This gear assembly consists of a plate assembly, a shaft with two bearings, a steel gear, and an overload clutch mechanism. The assembly provides means for making proper gear ratio arrangement between the motor and tape printer main shaft. One gear of an associated set of gears is mounted to one end of the intermediate gear assembly shaft. A steel gear in the assembly drives the main shaft of the typing unit.

2.04 The overload clutch mechanism is built into the steel driving gear of the assembly. It consists of a plate assembly, a lever and a spring. The lever is held in a notch inside the gear under tension of its spring. When the torque applied to the gear becomes greater than the force applied by the spring to the lever in its

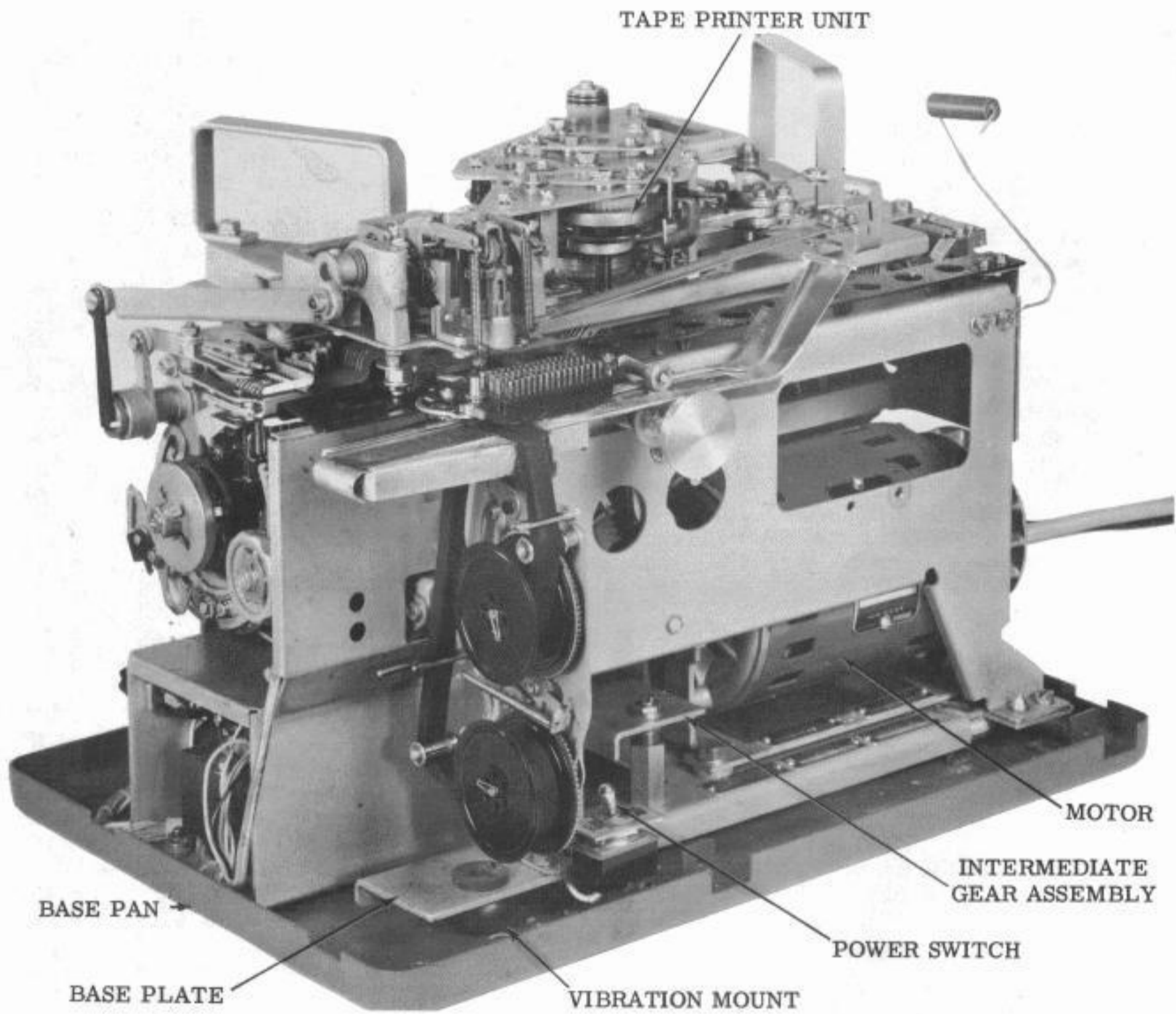

Figure 1

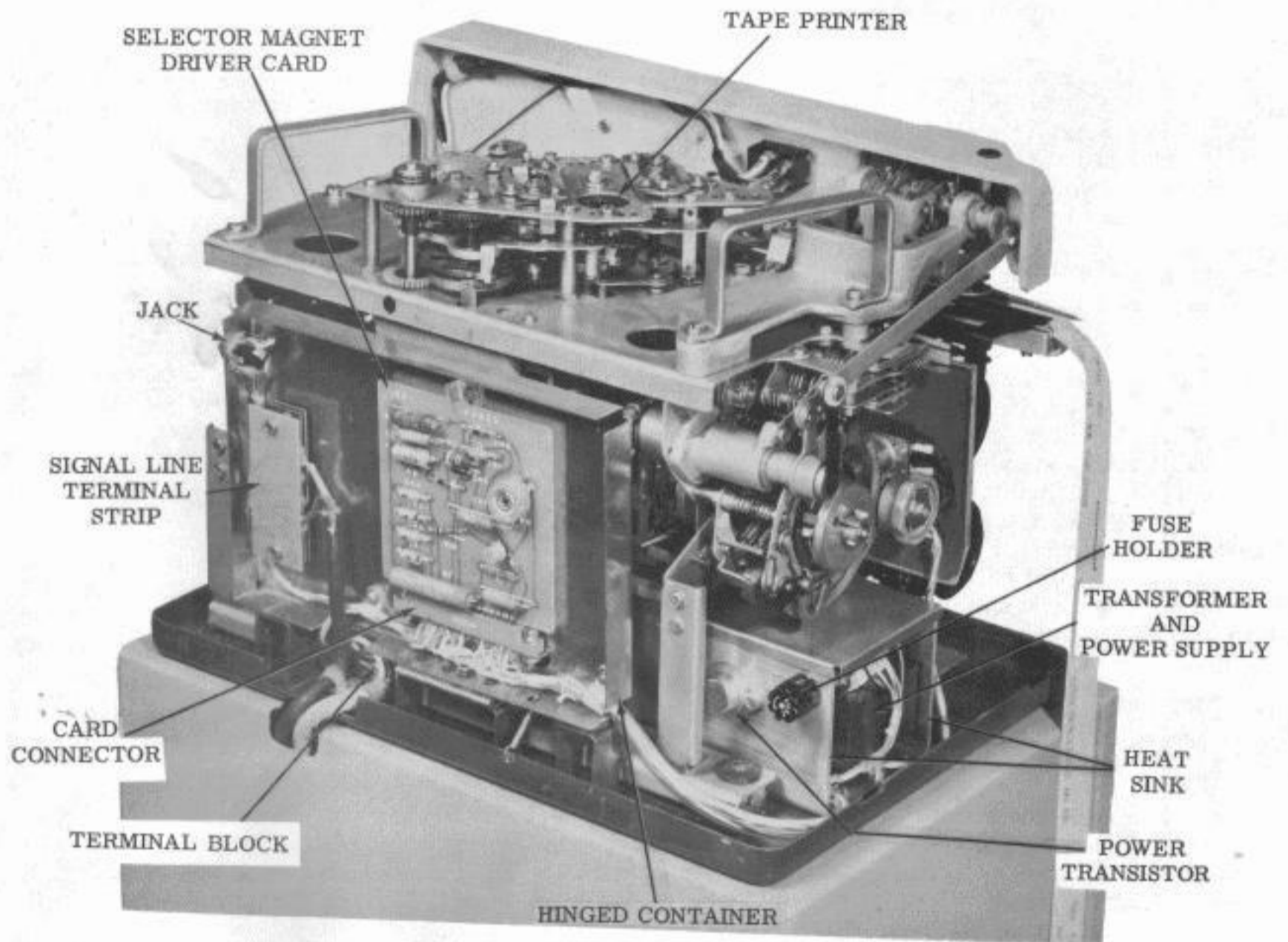

Figure 2

notch, the lever is forced out of its notch and rotates without the gear, thus providing a yield in the driving force. When this happens, a clanking noise that acts as an audible alarm is produced. To re-engage the clutch, if it should become disengaged, the power must be turned off and the motor rotated by hand until the throwout lever snaps back into its notch.

POWER SUPPLY

2.05 The power supply is mounted to the base pan near the left end. It consists of a transformer, two filter capacitors, power transistor mounted on a suitable heat sink and a cable assembly. It delivers necessary power to operate the electronic selector magnet driver card and the selector magnet.

SELECTOR MAGNET DRIVER

2.06 The selector magnet driver with its mounting assembly is mounted to the base pan at the rear of the tape printer unit (Fig. 2). The mounting assembly is a hinged container that permits access to the rear of the tape printer. A signal line terminal block, signal line measuring jack and the selector magnet driver card are mounted on the container.

A. Function

2.07 The electronic selector magnet driver, consisting of an etched circuit card with mounted components serves to couple polar telegraph signals to selectors requiring 0.500 ampere dc MARK signals and essentially zero current SPACE signals.

2.08 The signal line measuring jack is not functional with the selector magnet driver but is provided for use with a customer furnished more sensitive selector magnet driver.

B. Input Signals

2.09 The input signal is +0.020 to +0.060 ampere for MARK signals and -0.020 to -0.060 ampere for SPACE signals.

C. Input Impedance

2.10 The input impedance is nonreactive at approximately 10 ohms for 0.060 ampere input, 30 ohms for 0.020 ampere input and a similar inverse proportion for other currents.

D. Input Switching Levels

2.11 Switching is performed at approximately the zero current level as in a conventional polar telegraph repeating relay circuit.

E. Switching Principle

2.12 The basic circuit is a regenerative amplifier or flip-flop that produces full ON or OFF output without intermediate levels similar to relay contacts.

F. Output Wave Shaping

2.13 Output wave shaping is provided by a surge suppressing circuit that protects the output transistor from breakdown as the selector magnet field collapses from the application of a spacing signal. This circuit is designed to provide approximately equal magnet PULL-UP and DROP-OUT times.

G. Magnet Current

2.14 The magnet current is automatically regulated to the nominal 0.500 ampere level on MARK, in order to be independent of normal variations in power supply voltage, selector magnet, and current limiting resistance values.

3. CIRCUIT OPERATION (Figure 4)

POWER SUPPLY

3.01 The primary source of power is derived from a 117 volt ac source through the primary winding of a step-down isolation transformer (terminal 1 and terminal 2 Figure 4). The secondary winding voltage of terminal 3 and terminal 5 is converted to the nominal dc voltages by four rectifier diodes mounted on the magnet driver card. The output of the rectifier bridge, CR1 and CR3 for +20 volts dc and CR2 and CR4 for -20 volts dc, are filtered by a 500 microfarad capacitor and a 1500 microfarad capacitor, respectively. The dc voltages and the selector magnet driver circuit common are referenced to the center tap of the transformer.

SELECTOR MAGNET DRIVER

3.02 The electronic circuit of the selector magnet driver is a two-stage triggering amplifier capable of switching high output currents (0.500 amperes) at very closely controlled

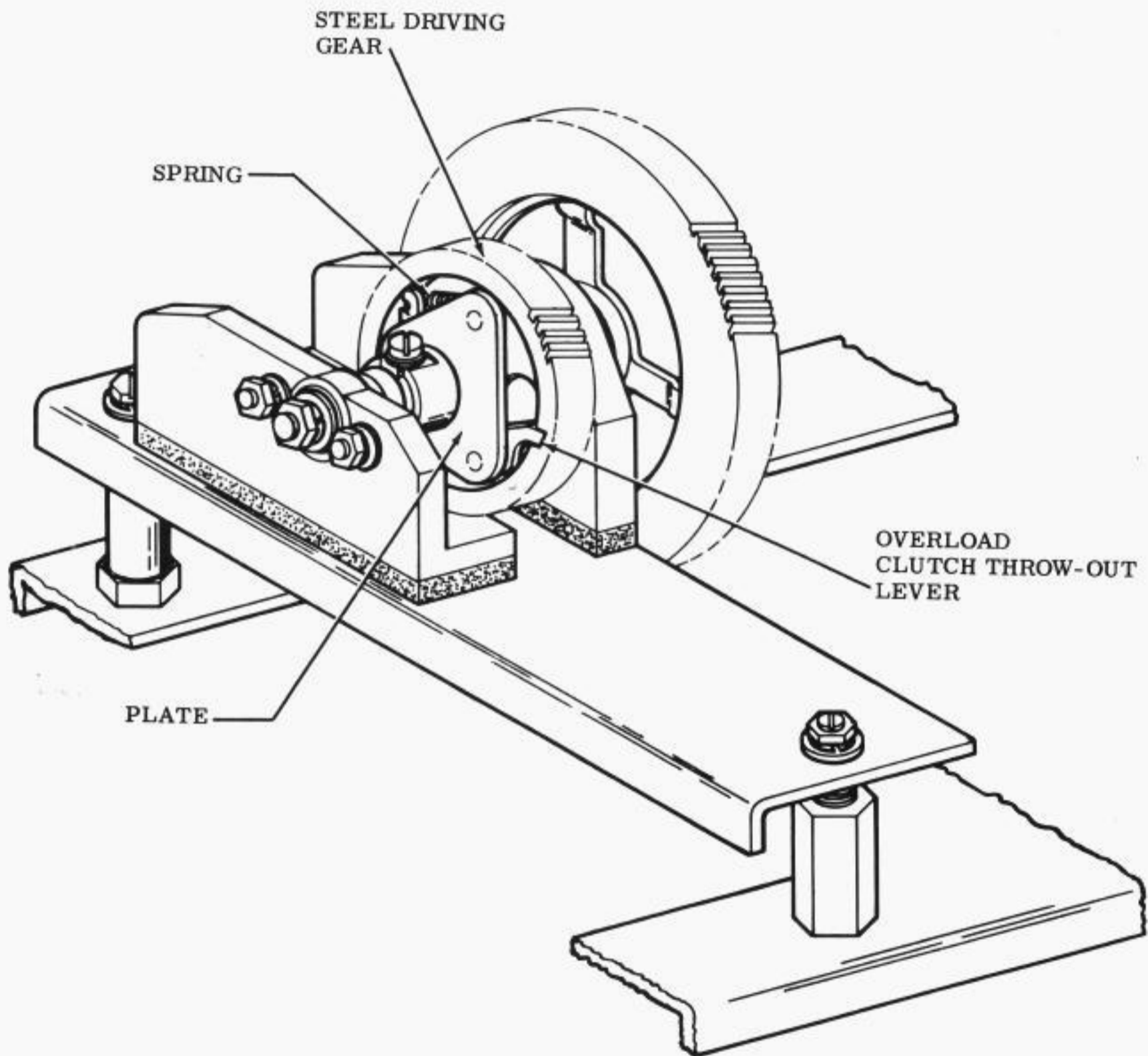
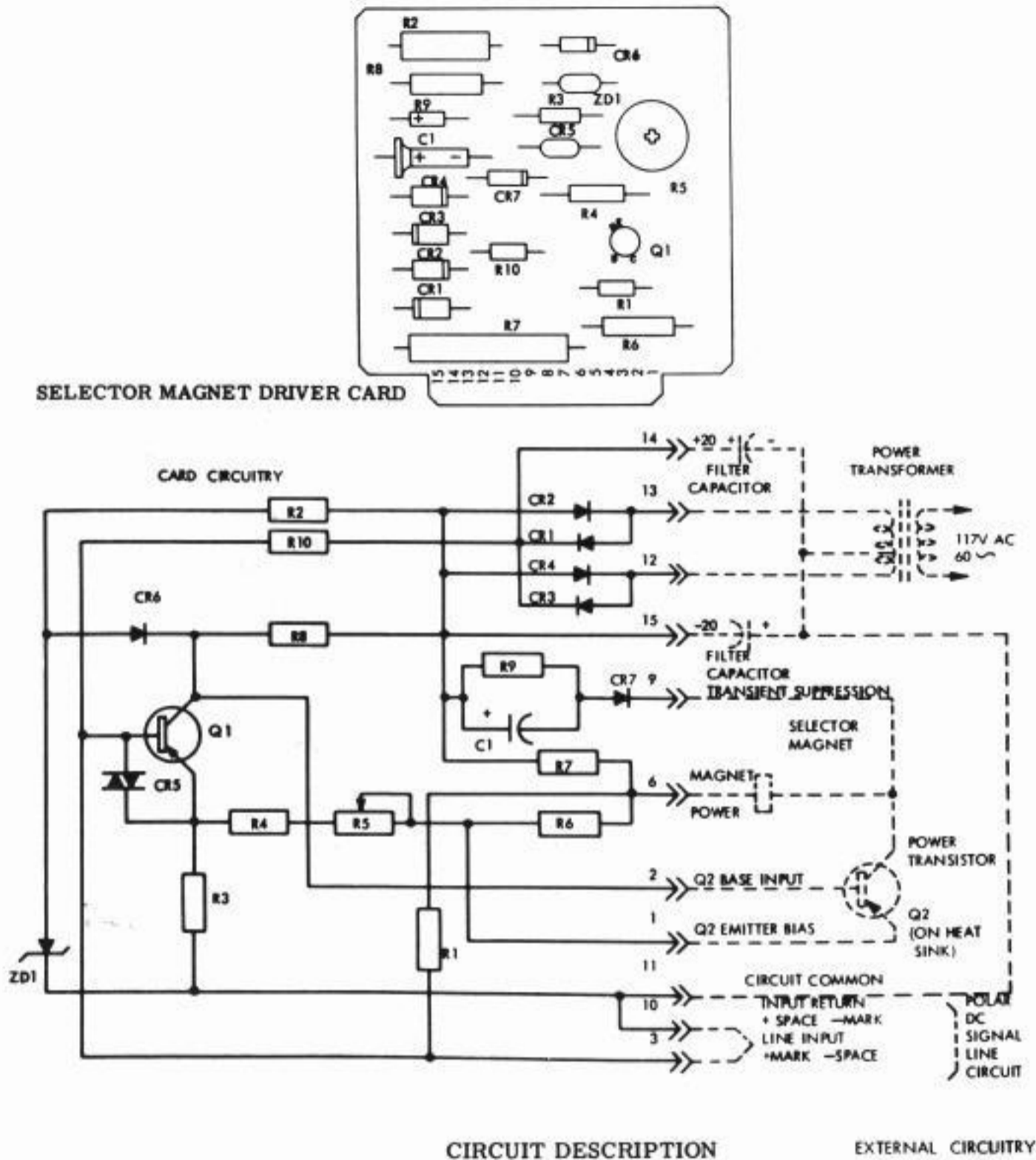

Figure 3 - Intermediate Gear Assembly



The selector magnet driver obtains primary power from a 117 volt ac source through a step down isolation transformer. Full wave rectification of the reduced voltage is provided by the four power rectifiers: CR1 and CR3 for +20 volts dc at terminal 14 and CR2 and CR4 for -20 volts dc at terminal 15. The power supply filter capacitors are connected to their respective dc voltage terminal and their common connected to terminal 11.

The polar direct current line circuit is connected through terminals 3 and 10. When the line input, terminal 3, is positive with respect to the input return, terminal 10, the marking condition prevails and when the line is negative with respect to the input return, the spacing condition prevails. In the marking condition, Q1 is biased off. The collector of Q1 and consequently the base of Q2 is clamped at the zener reference voltage by diode CR6. Q2 is connected as a constant current emitter follower. With -6 volts applied at its base, current flows through R3, R4, and R5, which develops 0.500 amperes. The current is adjusted by rheostat R5. The input current requirements for Q1 switching are determined by resistors R1 and R10. As the line input becomes negative with respect to the input return, Q1 begins to conduct. A regenerative action accelerates the conduction of Q1 and the reverse biasing of Q2 off. The Q2 protection network consisting of R9, C1, and CR7 suppresses the inductive transient caused by the selector magnet collector load.

Figure 4

input current levels. The power of the selector magnet driver is obtained through the combined operation of the circuit card and a power supply assembly located under the left end of the Tape Printer.

3.03 If the line circuit is opened during operation, the input transistor Q1 will remain either on or off depending upon the last condition before the line was opened. If Q1 is on when the line is opened, sufficient negative bias current is obtained through R1 for Q1 to remain on.

3.04 With Q1 conducting Q2 will be off, since the potential at the base of Q2 will be more positive than at the emitter. In this condition, only small leakage currents will flow in the collector circuit.

3.05 As a SPACE-TO-MARK transition begins, the negative bias current flowing in the base of Q1 is diverted to the line circuit. As the line current transverses the zero current level and rises toward the MARKING current value, it extracts base current from Q1. When the line current approaches the positive switching point current, Q1 begins to turn OFF. Q2 will then begin to receive forward bias current from R8 and begin to turn ON. The current supplied to the base of Q2 is amplified by Q2 and a current which is a multiple of the base current appears in the emitter circuit. This increase in emitter current causes an increase in the negative potential measured across R3. This increase in the negative potential at the emitter of Q1 will cause it to be further cut off. The feedback process continues until the current in the selector magnet reaches a value which is determined by the zener reference voltage, clamp diode CR6 and the emitter resistance of Q2 which is adjusted by rheostat R5 to compensate for component variations to 0.500 ampere selector magnet current.

3.06 As the line current completes the transition to the final MARKING current value, the base of Q1 becomes positively biased. The positive bias current will be approximately one-half the total MARKING line current. The positive potential developed at the base of Q1 is clamped to approximately 0.6 volts by the input protecting varistor CR5.

3.07 The line current in changing from MARK-TO-SPACE will transverse the zero current level and negative bias current begins to flow into the base of Q1. When the line current approaches the negative switching point current, Q1 begins to conduct. As Q1 begins to turn ON, the current through R8 will be diverted from the base of Q2 causing it to begin to turn OFF. As Q2 turns OFF, the voltage across R4 will begin to go positive, causing Q1 to be further turned ON. This effect gives regeneration to the MARK-TO-SPACE transition.

3.08 When Q2 is turned off during the MARK-TO-SPACE transition, a negative voltage transient is developed at its collector. This transient is due to dissipation of the energy stored in the magnetic field of the driven magnet when energized 0.500 ampere. If the high voltage developed at the collector of Q2 is not limited, it would continue to rise until the collector-to-emitter reach through breakdown voltage is exceeded. It has been found that repeated breakdown of this kind causes deterioration of the transistor and finally a collector-to-emitter short circuit. Therefore, it is necessary to provide a transient suppressing network at the collector of Q2. The transient suppression network presently in use is a compromise which affords a minimum peak voltage combined with a magnet release time which provides for adequate printer margins. The network consists of C1 in parallel with R9. CR7 isolates the network from voltages more positive than negative battery potential.

4. ADJUSTMENTS

INTERMEDIATE SHAFT ASSEMBLY POSITION

Requirement

Min 0.004 inch---Max 0.008 inch
of backlash between the typing unit gear and the intermediate driving gear at the closest point.

To Adjust

Loosen the screws which secure the intermediate gear assembly mounting post to the rear rail. Loosen the nut on the adjusting screw of the front mounting post and position the intermediate gear assembly. Tighten the rear post mounting screws.

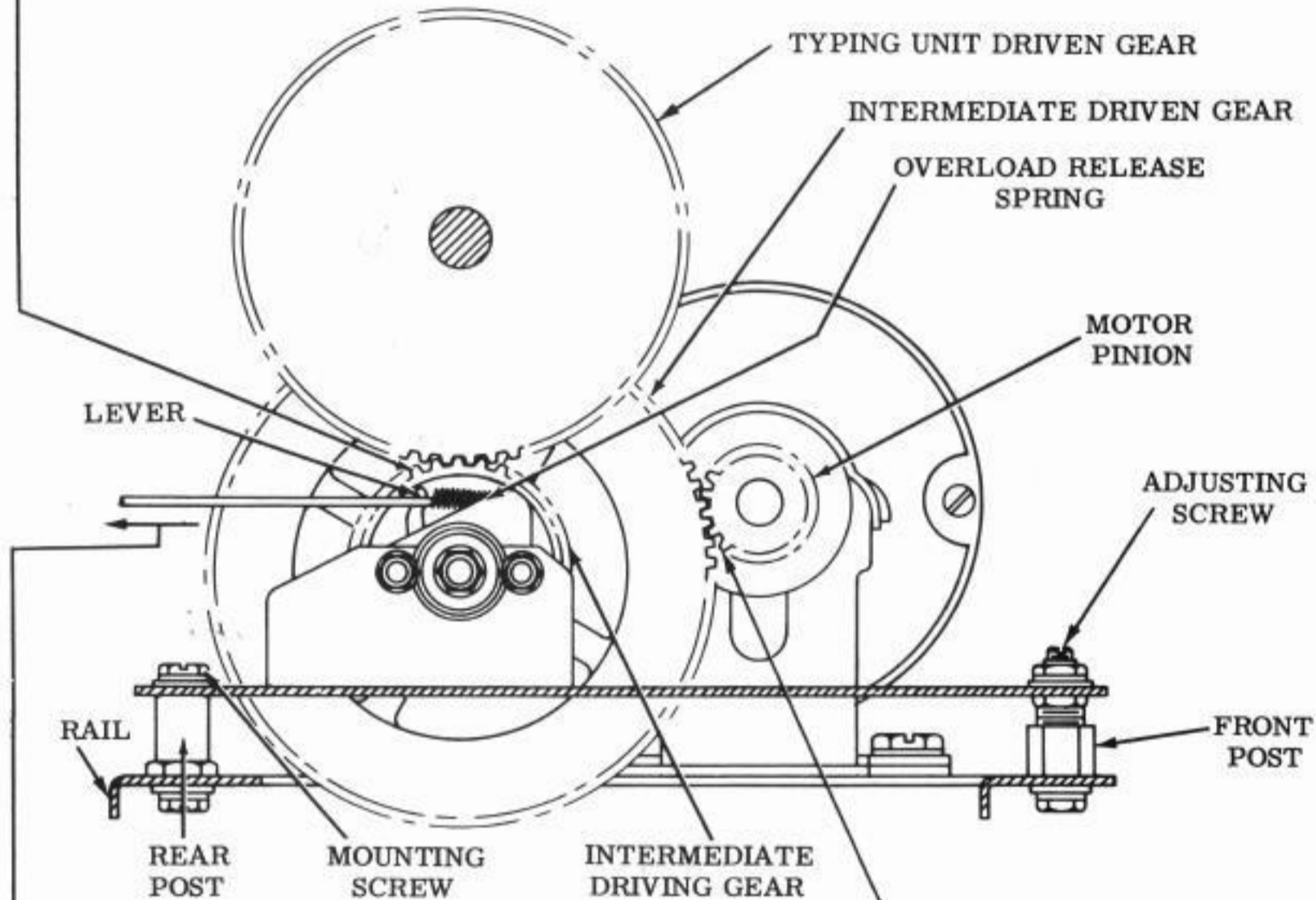

MOTOR PINION TO INTERMEDIATE GEAR

Requirement

Min 0.004 inch---Max 0.008 inch
of backlash between motor pinion and intermediate gear at closest point.

To Adjust

Raise or lower the intermediate gear assembly with the adjusting screw on the front post. Refine the intermediate shaft assembly position if necessary to obtain quiet operation.

OVERLOAD RELEASE MECHANISM SPRING

To Check

Hold plate of overload release mechanism stationary
Min 40 oz---Max 64 oz
to start lever moving.

5. LUBRICATION

