

28 KEYBOARD SEND-RECEIVE AND RECEIVE-ONLY
 TYPING REPERFORATOR SETS (KTR AND ROTR)
 INSTALLATION AND CHECKOUT

CONTENTS	PAGE
1. GENERAL	1
2. TECHNICAL DATA	1
SIZE AND WEIGHT	1
POWER SUPPLY REQUIREMENTS	2
3. INSTALLATION	2
UNPACKING	2
INSTALLATION OF KEYBOARD SEND-RECEIVE TYPING REPER- FORATOR SET	2
INSTALLATION OF RECEIVE-ONLY TYPING REPERFORATOR SET	6
ELECTRICAL AND SIGNAL CIRCUITRY	7
4. CHECKOUT	7
GENERAL	7
A. Tape Threading	7
B. Ribbon	7
C. Power Switch	8
D. Gears	9
E. Keyboard Operation	9

1. GENERAL

1.01 This section is issued to outline the assembly of components and to provide installation and checkout procedures for the keyboard send-receive and receive-only typing reperforators. It also provides requirements and adjustments needed so that the components operate properly as a set.

1.02 In this section all references to the location of parts are made from the operator's position at the front of the set.

1.03 For illustration and location of part numbers used, refer to the appropriate parts section.

1.04 The complete set consists of the following basic units:

Keyboard Send-Receive Typing Reperforator Set

- Typing reperforator keyboard
- Motor unit
- Set of gears
- Typing reperforator
- Cover

Receive-Only Typing Reperforator Set

- Reperforator base
- Motor unit
- Set of gears
- Typing reperforator
- Cover

2. TECHNICAL DATA

SIZE AND WEIGHT

2.01 The approximate size (in cubic feet) and weight (including equipment spares) of the sets is as follows:

(a) Keyboard Send-Receive Set

Crated: 18.2 feet; 238 pounds
 Uncrated: 10.0 feet; 119 pounds

(b) Receive-Only Set (Standard Size)

Crated: 8.5 feet; 115 pounds
 Uncrated: 4.4 feet; 61 pounds

(c) Receive-Only Set (Miniaturized)

Crated: 8.5 feet; 110 pounds
 Uncrated: 4.3 feet; 57 pounds

2.02 Refer to Figure 1 for an outline and minimum mounting dimensions of the sets and Figure 2 for bulkhead or counter installation drilling specifications for shock mounts.

POWER SUPPLY REQUIREMENTS

2.03 The following requirements apply to the motors used with the Transmitter Distributor Sets.

(a) Ac synchronous motor (LMU3)

Input voltage	115 v ac, + 10%
Phase	single
Frequency	60 Hz, + 0.5%
Input current, starting	9 amp
Running	1.85 amp
Watts	65 watts
Power factor	No load, 23.7%
	Full load, 38.5%
Heat dissipation	50 watts
Horsepower	0.050

(b) Miniaturized ac synchronous motor (LMU24)

Input voltage	115 v ac, + 10%
Phase	single
Frequency	60 Hz, ± 0.5%
Input current, starting	5 amp
Running, no load	1.05 amp
Full load	1.25 amp
Horsepower	0.025

(c) Ac governed motor (LMU4)

Input voltage	115 v ac, + 10%
Phase	single
Frequency	50 to 60 Hz
Input current, starting	1.75 amp
Running	1.00 amp
Watts	95 watts
Power factor	No load, 71%
	Full load, 66.8%
Heat dissipation	75 watts
Horsepower	0.50

2.04 The ambient operating temperature of the sets is -20°C (-4°F) to $+50^{\circ}\text{C}$ ($+122^{\circ}\text{F}$). The temperature rise should not be in excess of $+40^{\circ}\text{C}$ ($+104^{\circ}\text{F}$) above ambient temperature.

3. INSTALLATION

UNPACKING

3.01 The reperforator sets are shipped as component assemblies. Each component is packaged individually. Carefully cut the sealed edges of the carton so as not to damage the component. When the unit is fastened to a shipping pallet (for example, a typing unit or motor unit), it is preferable to cut the sealed edges at the bottom of the carton, then fold back the flaps so that the pallet rests directly on the bench or floor; then lift carton off. The cloth bag containing small parts should remain tied to the unit until the parts are required for the installation.

INSTALLATION OF KEYBOARD SEND-RECEIVE TYPING REPERFORATOR SET

3.02 Install drive pinion on motor shaft using rubber isolators and parts provided with gear set.

3.03 Install driven gear on hub of intermediate gear assembly of the base using two screws provided on hub.

3.04 Install motor unit. Place the TP152045 gear guard over left rear mounting hole and fasten motor with four TP151678 screws provided in cloth bag. Remove fibre insulator from 4-point terminal block on base and connect motor leads to terminals 1 and 2 per applicable wiring diagrams. Replace insulator.

3.05 Motor pinion to intermediate gear adjustment:

(a) Requirement: There should be a barely perceptible backlash between motor pinion and intermediate gear throughout a complete revolution of the gear.

(b) To Adjust: Raise or lower front end of intermediate gear bracket by means of fillister head adjusting and clamping screws. Refine adjustment if necessary.

3.06 Remove and discard the TP151442 mounting screw, retain the TP2191 lockwasher from the main shaft of the typing reperforator. Mount the TP156226 hub on the shaft using a TP151632 screw and the retained lockwasher. Mount the TP161897 gear on hub using the three TP151695 screws and the TP161831 spring washer.

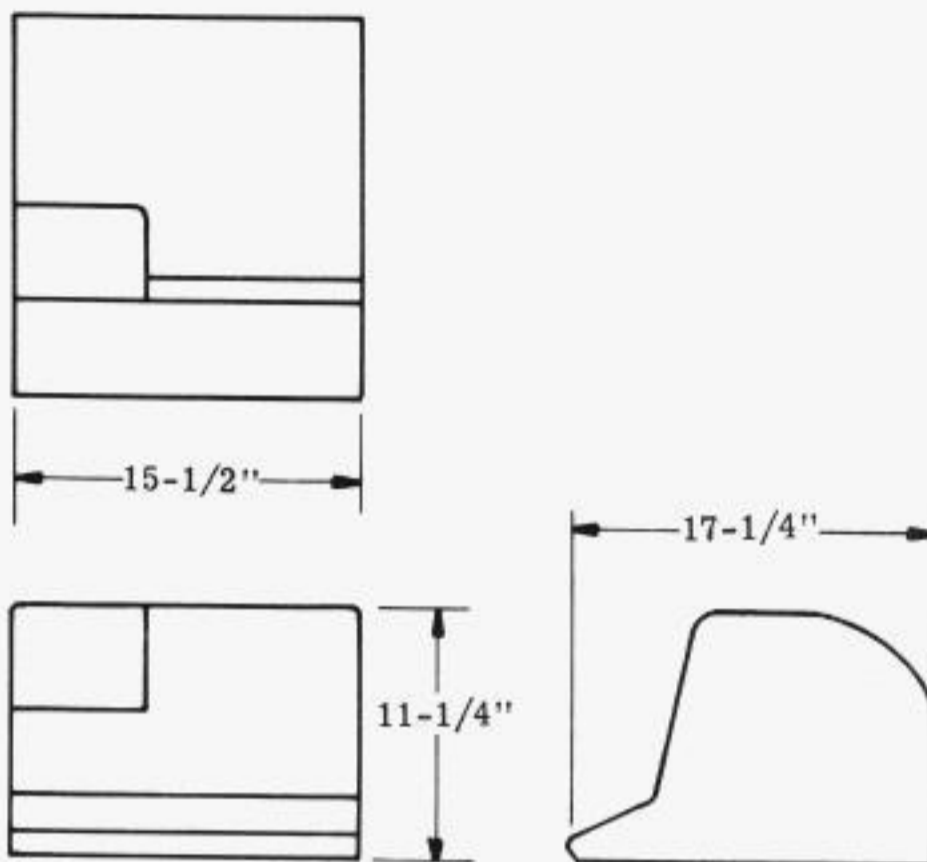

Keyboard Send-Receive Set

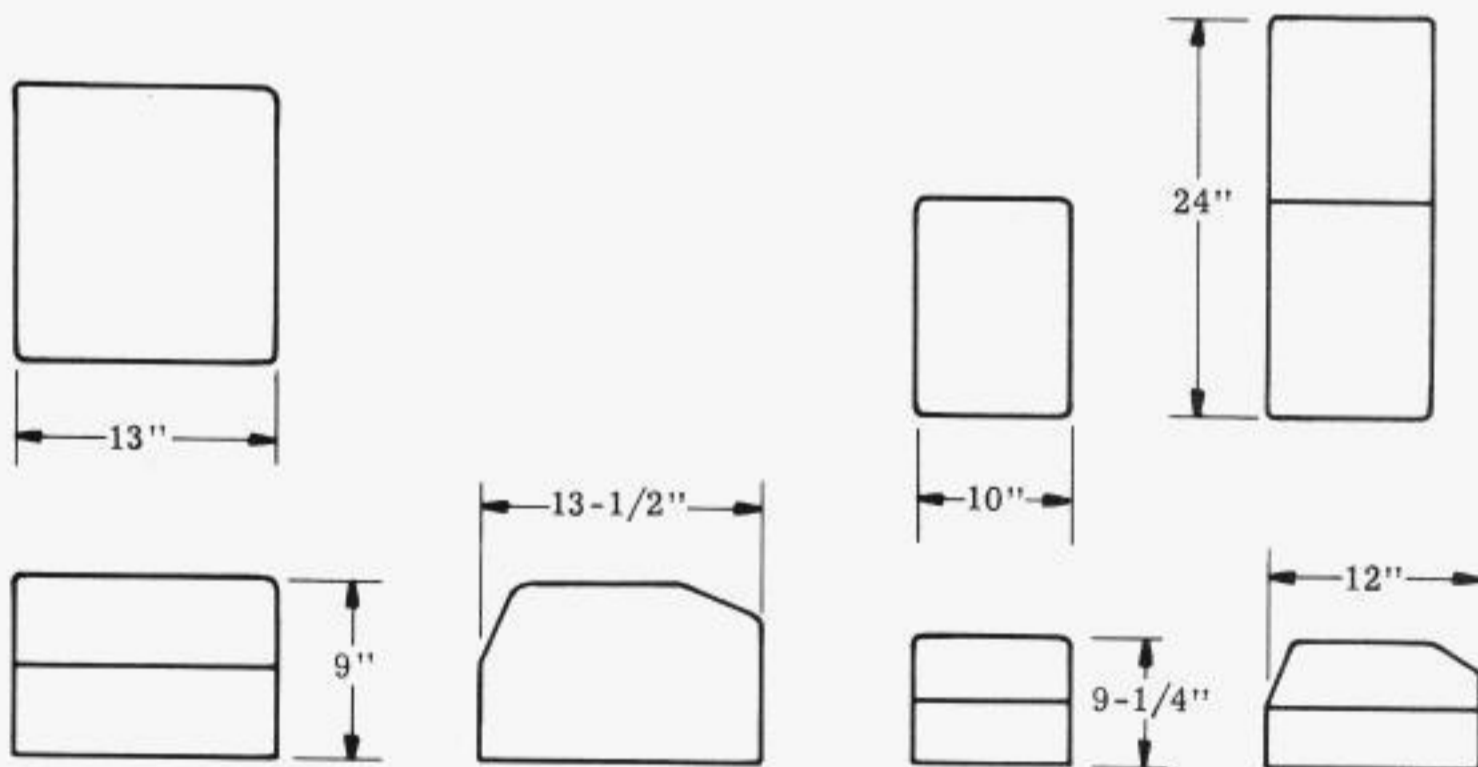

Receive-Only Set (Standard Size)

Receive-Only Set (Miniaturized)

Figure 1 - Outline and Mounting Dimensions

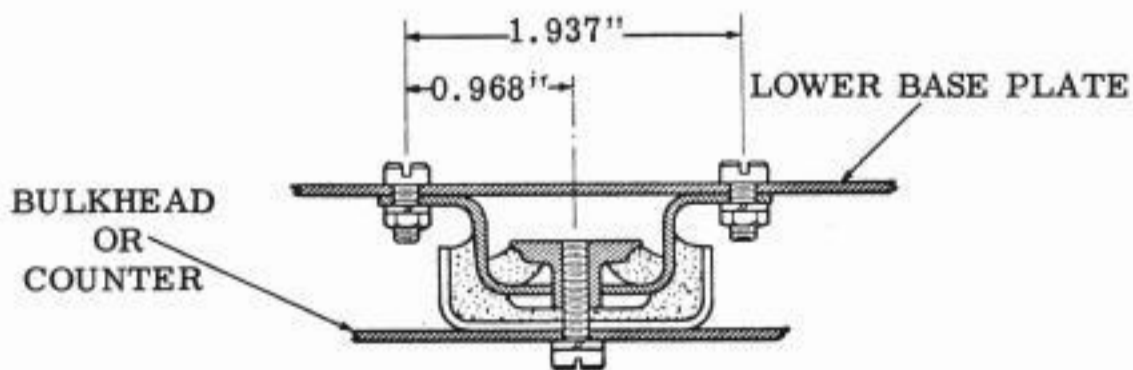
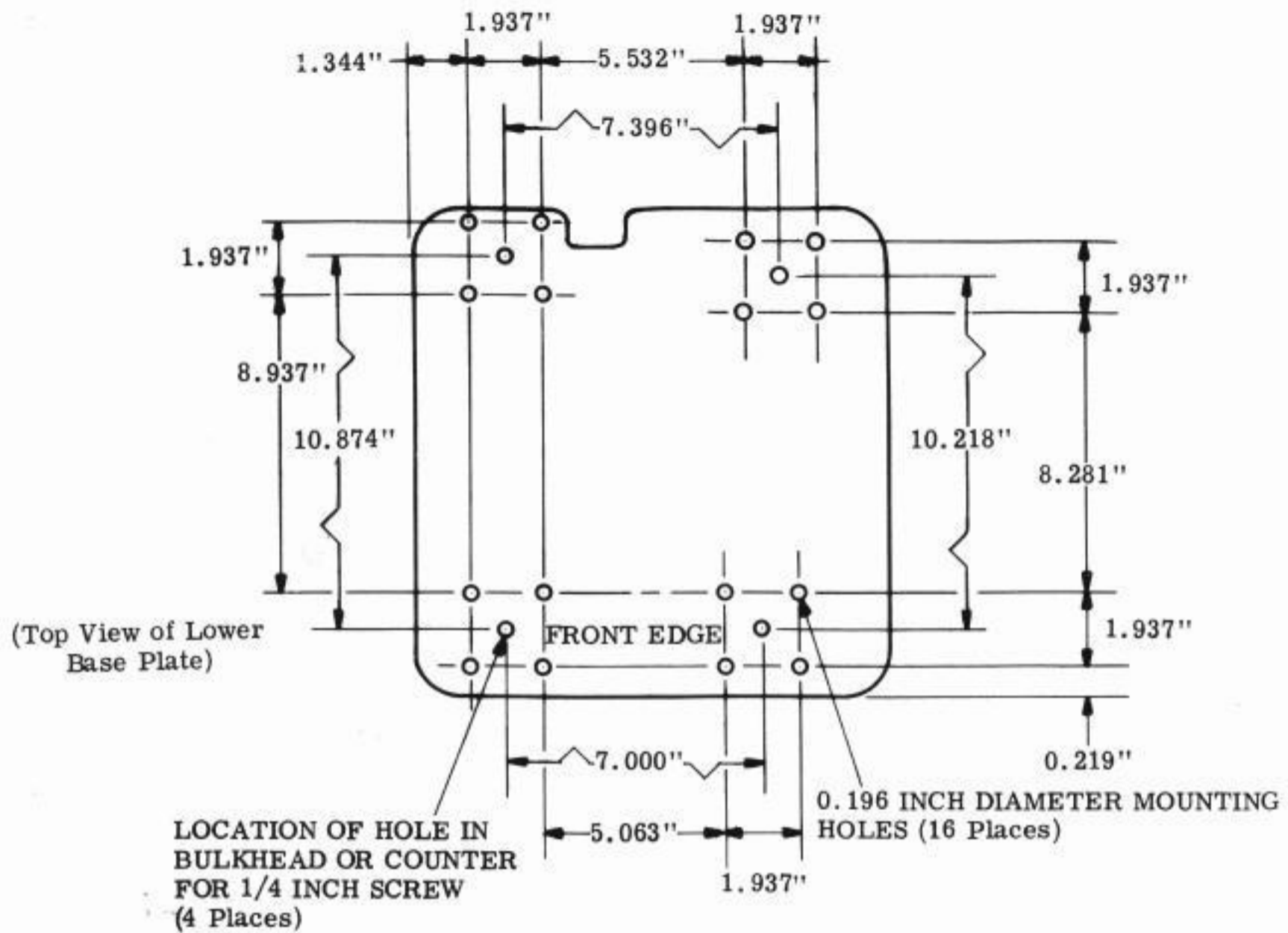

Figure 2 - Bulkhead or Counter Installation Drilling Specifications for Shock Mounts

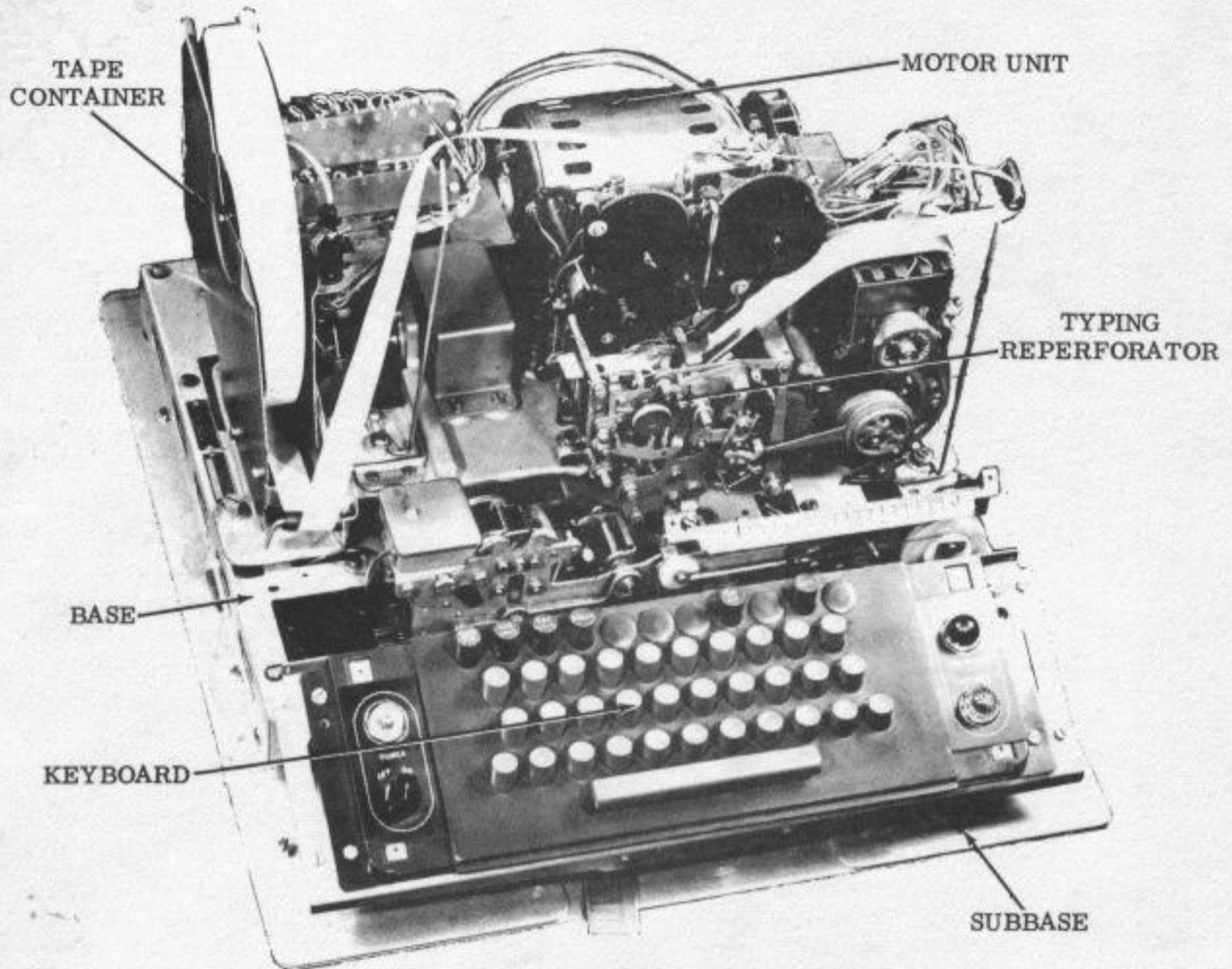

Figure 3 - Typical 28 Keyboard Send-Receive Typing Reperforator Set (Cover Removed)

3.07 Install the typing reperforator using the three TP78301 screws, three TP3639 lockwashers, three TP3438 flat washers, one TP151631 screw, one TP2191 lockwasher, and one TP125015 flat washer. The typing reperforator driven gear should be positioned in line with its drive gear.

3.08 Intermediate Gear Assembly To Reperforator Gear Adjustment: There should be a barely perceptible amount of backlash between intermediate gear and reperforator gear throughout a complete revolution of the larger gear.

3.09 Apply a thin film of KS7471 grease to all gears.

3.10 Route the tape as shown in Figure 3. Operate the unit; tape should feed over approximate center of rollers and feed smoothly without any binding. Bend tape guides to meet requirements.

3.11 A 16-point connector is provided for connecting the reperforator to the base. It is necessary to strap together terminals 1 and 9. Terminal 2 is the grounded side and terminal 11 is the ungrounded side of the power line. Terminals 8 and 11 are the signal circuit. See applicable wiring diagram.

3.12 Mount keyboard typing reperforator on subbase of cover using the TP151549 screws which are found on subbase. Move latch

handle to left and place cover on subbase. Make sure that cables exit through notched portion of cover at rear and that cover is resting directly on subbase. Open access door and plug in cover cable connector. Move latch to right to lock cover to subbase.

- 3.13 When the associated typing reperforator unit is equipped with a backspace feature, the TP151540 character counter lampholder should be adjusted to the extreme upper position.

CAUTION: TO CLEAN GOLD CONTACTS IN UNITS SO EQUIPPED, PASS TWILL JEAN CLOTH BETWEEN THE CLOSED CONTACTS OF THE SIGNAL GENERATOR; AVOID PULLING THE TWILL JEAN COMPLETELY THROUGH THE CONTACTS. OPEN CONTACTS TO RELEASE THE TWILL JEAN CLOTH. USE NO OTHER CLEANING OR BURNISHING METHODS. AVOID PITTING OR CHIPPING THE GOLD CONTACT POINTS. DO NOT TOUCH THE CLEANED CONTACT SURFACES.

INSTALLATION OF RECEIVE-ONLY TYPING REPERFORATOR SET

- 3.14 Remove the two TP161630 screws and TP2191 lockwashers holding the TP156904 gear-guard of intermediate shaft assembly casting. Set these parts aside.
- 3.15 Remove the TP151346 screw and TP2191 lockwashers from the shaft and TP156226 hub. Remove hub from shaft.
- 3.16 Select gear set for the desired speed.

Speed	Speed		Gear	Motor Pinion
	WPM	OPM		
60	368	TP161654	TP156981	TP156982
66	404	TP161519	TP161103	TP161104
75	460	TP161655	TP156983	TP156984
100	600	TP161656	TP156985	TP156986

Mount gear on hub using three each of TP151695 and TP2191 screws and lockwashers. Mount gear with counterbored holes away from hub. Do not tighten screws. To align gear, hub, and shaft, slip assembly onto intermediate shaft with hub side first, tighten gear mounting screws. The assembly is removed and remounted with gear side first on the shaft. Secure hub to shaft using screw and lockwasher found in cloth bag attached to base (3.15).

- 3.17 Mount motor pinion on motor shaft using the TP151346 screw and TP2191 lockwasher.

3.18 Remove the following parts from attached bag: one TP156334 stud, one TP156344 adjusting bracket, one TP125224 1/4-32 nut, five TP2449 lockwashers, and four TP156936 1/4-32 x 5/16 screws. Thread the TP156334 stud in motor mounting post to immediate left of driven gear. Do not tighten at this time. Using two TP156936 screws and two TP2449 lockwashers, mount adjusting bracket to gear end of motor with center hole extending beyond motor mounting plate. Place motor with bracket over three motor mounting posts with hole in adjusting bracket passing over stud in right post. Fasten fan end of motor with two TP156936 screws and two TP2449 lockwashers to the two posts, taking up all slack in mounting holes to extreme left position. Place remaining TP2449 lockwasher and TP125224 nut on stud holding adjusting plate. Tighten nut friction tight.

3.19 Remove the TP156400 sprocket from bag attached to drive assembly. Mount sprocket to hub on reperforator using screws and lockwashers already fastened to hub. The screw heads and lockwashers should be on the side of the deeper inset of the sprocket.

3.20 To mount reperforator onto base, remove the following from bag attached to base: three TP156887 10-32 x 9/16 hex head screws, three TP2699 lockwashers, three TP3438 flat washers, one TP151631 6-40 x 5/16 hex head screw, one TP2191 lockwasher, and one TP7002 flat washer. Place reperforator over its mounting holes in base. Loosen screw holding small TP156183 L-bracket to lower right front corner of punching mechanism. Start the TP151631 screw with the TP2191 lockwasher and the TP7002 flat washer through the TP156183 L-bracket into the proper tapped hole in base plate. Do not tighten screw. Start the three TP156887 screws with TP2669 lockwashers and the TP3438 flat washers through casting holes in base plate. Do not tighten screws. Press the TP156183 L-bracket against base plate and tighten screw holding bracket to punching mechanism. Tighten screw holding bracket to base. Tighten the three TP156887 mounting screws.

3.21 Remove the TP156866 toothed belt from bag attached to base. Loosen intermediate shaft assembly mounting screws. Slip belt over sprockets on intermediate shaft assembly and reperforator drive shaft. Move intermediate shaft assembly away from motor until there

is a deflection of 1/8 inch when a pressure of 8 ounces is applied to the belt midway between sprockets. Tighten screws.

3.22 The motor pinion and intermediate gear should have a barely perceptible backlash, adjust stud in right motor mounting post up or down as needed. Tighten nut on stud while holding stud. Loosen mounting screws on intermediate shaft casting if gears do not mesh at right angles. Correct angle and maintain tension on toothed belt as described in 3.21. Tighten casting screws. Recheck backlash.

3.23 Lubricate motor pinion and intermediate gear with KS7471 grease. Do not lubricate the sprockets over which the belt rides.

3.24 Remount gear guard on intermediate drive shaft casting using its screws and lockwashers (3.14).

3.25 Mount tape container along right edge of base with tape guide toward front. Remove two TP151623 10-32 x 3/8 hex head screws, two TP2669 lockwashers, and two TP3438 flat washers from the bag attached to the base and use to secure container to base.

3.26 The right hand or "low" tape switch should operate before the left hand or "tape out" switch. The low tape switch should operate when the tape roll diameter is reduced to 2-7/16 inches. The tape out switch should operate when the diameter is further reduced to 2-5/16 inches. To adjust, bend switch levers to meet requirements. To facilitate adjustment remove switch assembly from tape container.

ELECTRICAL AND SIGNAL CIRCUITRY

3.27 See appropriate wiring diagrams.

3.28 Cable connectors will be found on their associated base connector.

4. CHECKOUT

GENERAL

4.01 Check mating of all connectors and receptacles. Check screw terminal connections and lamps for loosening or breakage. On some sets check fuse.

4.02 The main power switch should be in the down (OFF) position before closing the main power line to the set.

A. Tape Threading

4.03 Thread the tape according to Figure 4. Threading is identical for all units within the typing reperforator mechanism, but the path from the tape container is adapted to the particular unit.

4.04 All typing reperforator sets print upon and perforate standard teletypewriter tape supplied in eight-inch rolls on a two-inch spool. Remove the tape container hub from the tape container and insert it through the spool. On most units the tape feeds from right to left. However, in some receive-only units the tape feeds from left to right. Insert hub and roll into tape container to feed from bottom of roll. Make certain the low tape switch lever is riding on the outer edge of the tape roll when the tape is installed in the container.

4.05 Cut or tear the leading end of the tape square and feed it from the base tape guide rollers or loop into the tape chute. Push the tape downward around the die wheel to the point where it will be engaged by the feed wheel. Turn the manual feed thumbscrew counterclockwise to thread the tape between the feed wheel and the die wheel, under the tape shoe, and through the punch block.

4.06 Extend the tape beyond the edge of the cabinet or cover tape aperture, closing the access door with the tape protruding.

B. Ribbon

4.07 Open the cabinet or cover access door. The ribbon (Figure 5) mounts in a vertical position at the top of the reperforator, held in place on each of two ribbon spool shafts by a toggle lever. Engage the hook on the end of the ribbon in the hub of an empty spool (retain one spool if replacing a used ribbon). Wind a few turns of the ribbon onto the empty spool to make sure that the reversing eyelet has been wound upon the spool. The left spool winds clockwise, the right counterclockwise. Install the empty spool over the open toggle of its spindle, and turn the spool slightly until the driving pins on the shaft engage the holes in the rear of the spool. Close the toggle, and thread the ribbon around the roller, through the reversing pins (making sure the eyelet is always above the pins) for both

spools, over the left (or under the right) roller and to the opposite spindle. Place the spool on the spindle. Rotate the spool to take up the slack in the ribbon. Latch the second toggle. The ribbon properly installed should feed from the outside of each ribbon spool and should reverse whenever an eyelet engages a set of reversing pins.

C. Power Switch

4.08 Turn the power switch ON to prepare the equipment for automatic operation as receive-only sets responsive to incoming signal

line impulses, or for combined send-receive operation. On receive-only sets the main power switch is a toggle-type switch located at the right side of the front of the cover and accessible through apertures in the cover. Send-receive sets are equipped with a rotary-type switch located at the left side of the keyboard. By rotating this switch counterclockwise the pilot light above the switch lights and the set is turned ON.

CAUTION: BE SURE THE POWER SWITCH IS OFF BEFORE TURNING ON THE EXTERNAL POWER SUPPLY.

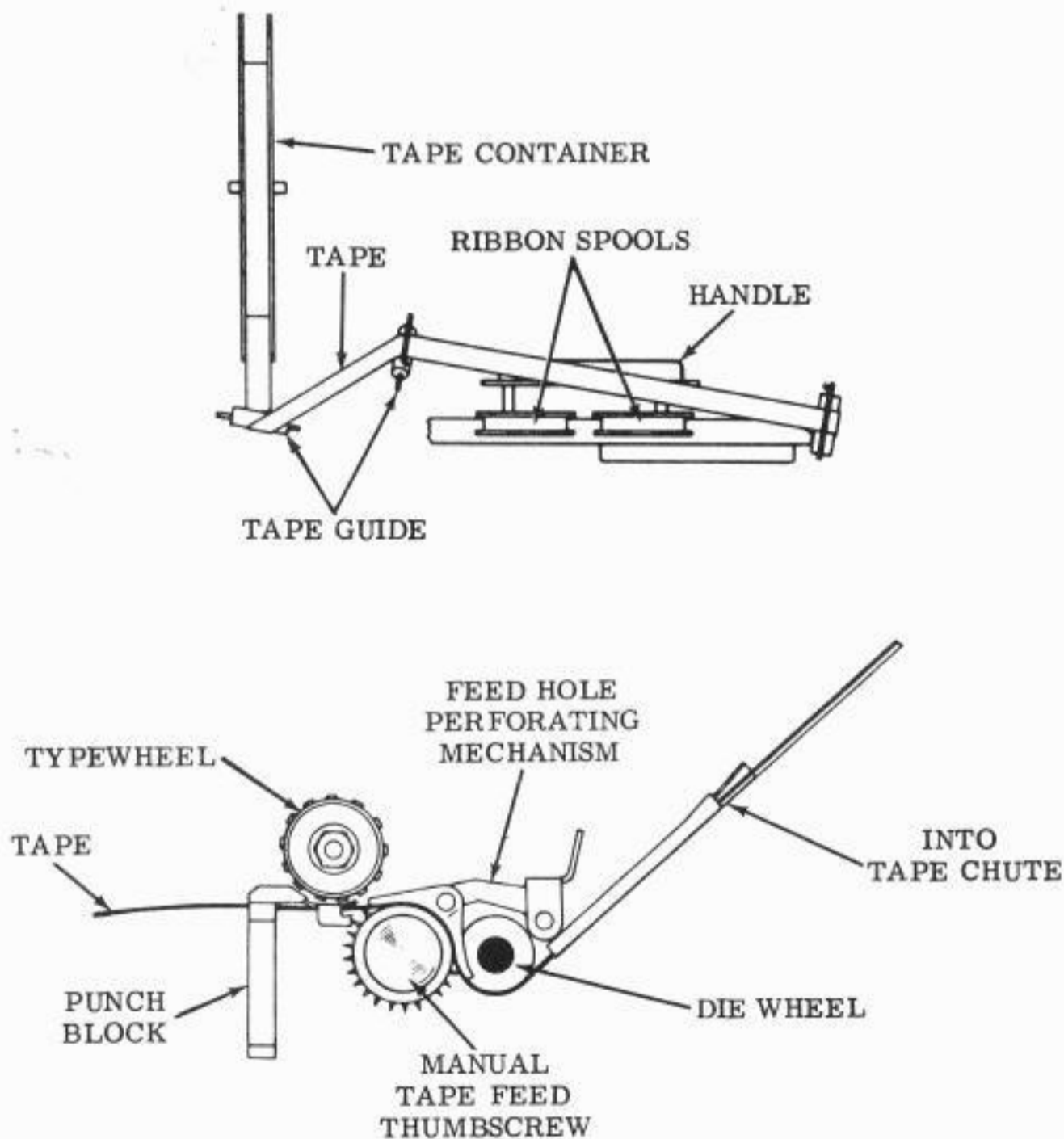

Figure 4 - Path of Tape

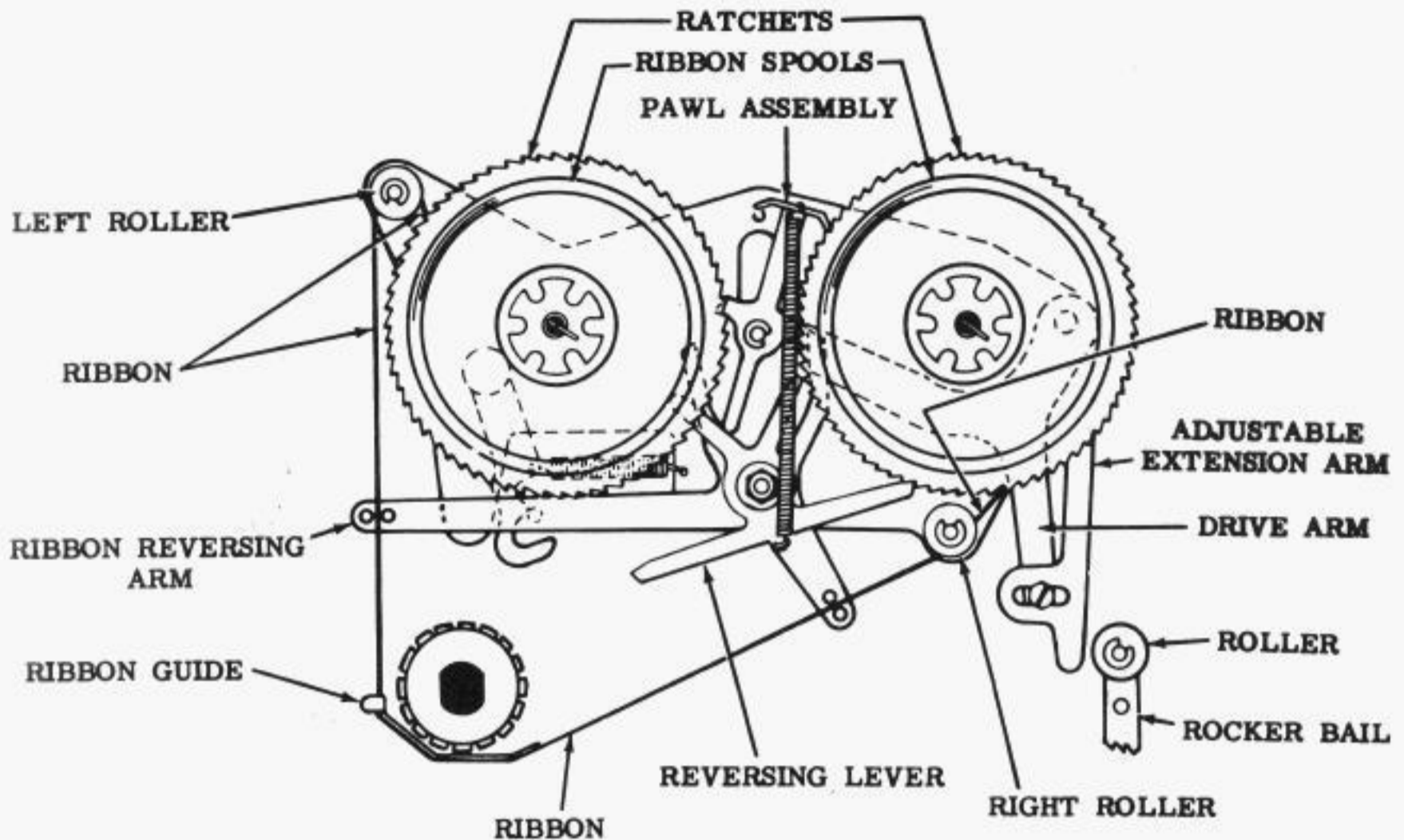

Figure 5 - Path of Ribbon

D. Gears

4.09 Send-receive sets are equipped with gears of a given speed. Before operating the set make sure any other receiving equipment looped with it is equipped with the same gearset. Receive-only sets may be equipped either with a single speed set of gears or with a variable speed mechanism which allows the set to operate at typical speeds of 60, 75, or 100 words per minute. Before the equipment is operated make certain that the set gears are compatible with the speed of the sending equipment. The variable speed mechanism has a selecting lever at the rear of the set which may be moved to obtain the desired speed.

CAUTION: OPERATE THE SPEED SELECTOR LEVER WITH THE MOTOR OFF.

E. Keyboard Operation

4.10 Visually check operation of the tape feed-out magnet armature when the TAPE FEED-OUT button (TAPE FEED-OUT key for send-receive sets) is depressed. The armature should be pulled down. Tape feed-out will not take place, however, since the set is running open (no signal circuit) and tape feed is continuous.

4.11 Close the external signal circuit. The typing reperforator should run closed (marking signal circuit) until an incoming signal initiates perforating and typing functions.

4.12 Check an incoming message by inspecting the typed tape and comparing the coded equivalent (six characters in advance of the typed

character) with the typed character. The punch mechanism and the typing mechanism are factory adjusted for satisfactory operation without installation adjustment. The quality of the input signal, however, may require refinement of the orientation range setting.

4.13 Check keyboard functions on send-receive sets by operating the keys under power and checking the tape prepared in the typing reperforator.

4.14 With the motor switch ON depress the KBD UNLK (keyboard unlock) key. Type any typical test message. Note that the indicator on the character counter advances one unit for each character. The character counter lamp at the right side of the keyboard should be illuminated between 66 and 68 characters. Depress the CAR RET (carriage return) key when the end-of-line indicator lamp is lit. The lamp should be extinguished, and the character counter indicator should return to zero position.

4.15 Depress the TAPE B SP (tape backspace) key. Tape in the typing reperforator should be moved one character to the right of the punch block.

4.16 Depress the TAPE F.O. (tape feed-out) key. Tape should automatically feed out of the typing reperforator to a predetermined length. Depending on the type of feed-out mechanism in the set this feature must be checked accordingly. The set may be equipped with either an interfering or a noninterfering feed-out mechanism. Feed-out may be accomplished either automatically or manually.

4.17 Depress the RPT (repeat) key simultaneously with any other character key. Transmission of the character should be continuous until the character key is released.

4.18 Depress the BREAK key. The typing reperforator should run open, indicating an interruption in the signal circuit.

4.19 Depress the KBD LOCK key. All keys on the keyboard should lock.

4.20 There are three lamps on the send-receive set. They are the power pilot light, end-of-line indicator lamp, and the low-tape lamp. The Miniaturized Typing Reperforator Set has only the low-tape lamp. Make sure these lamps are operative.