

NONCODED TOOLS

COPPERS AND IRONS (SOLDERING)

DESCRIPTION

<b>COPPER, SOLDERING, KS-8740 L1</b> Replaced by Copper, Soldering, KS-8740 L2	Manufacture Discontinued
<b>COPPER, SOLDERING, KS-8740 L10</b> Replaced by Copper, Soldering, KS-8740 L11	Manufacture Discontinued
<b>COPPER, SOLDERING, KS-8740 L21</b> Replaced by Copper, Soldering, KS-8740 L22	Manufacture Discontinued

**COPPER, SOLDERING, KS-8740** (Furnished without tip, which must be ordered separately)  
Word orders for soldering coppers and tips as follows:  
(Quantity) Copper, Soldering, KS-8740 L (number)  
(Quantity) Tip, KS-8740 L (number) L numbers for tips are given in the illustrations.

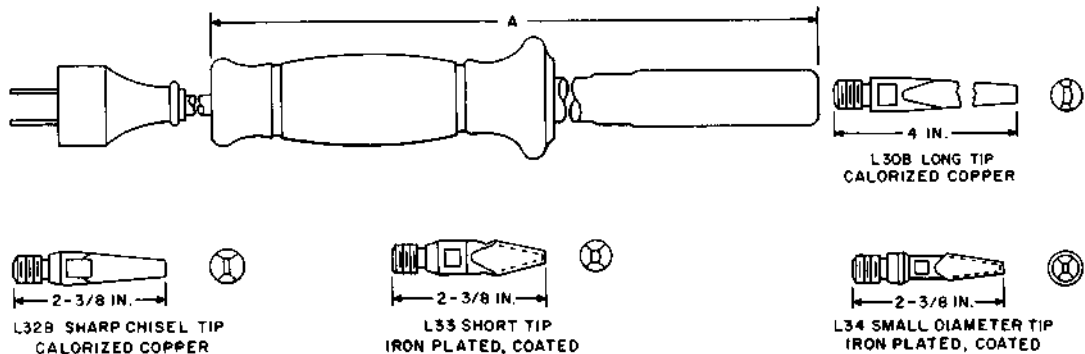

DESCRIPTION OF KS-8740 SOLDERING COPPERS

LIST NUMBER	WATTAGE	LENGTH DIM. A	CORD LENGTH	PLUG TYPE
2	95	11"	20 ft.	par nonpol
3	95	11"	6 ft.	par nonpol
9	110	11"	20 ft.	par nonpol
11	95	11"	9 ft.	par nonpol
13	95	11"	6 ft.	3 wire gnd
22	95	16-1/4"	20 ft.	par nonpol

For a soldering copper holder, refer to the 504A tool.

For piece-part data and maintenance information, see Section 075-191-812.

For general use.

SECTION 074-591-101

---

COPPER, SOLDERING, KS-14440 L1 Replaced by Copper, Soldering, KS-14440 L2	"Mfr Disc."
COPPER, SOLDERING, KS-14440 L2 Replaced by Copper, Soldering, KS-14440 L6	"Mfr Disc."
COPPER, SOLDERING, KS-14440 L3 Replaced by Copper, Soldering, KS-14440 L7	"Mfr Disc."
COPPER, SOLDERING, KS-14440 L5 Replaced by Copper, Soldering, KS-14440 L8	"Mfr Disc."
COPPER, SOLDERING, KS-14440 L6 Replaced by Copper, Soldering, KS-14440 L16	"Mfr Disc."
COPPER, SOLDERING, KS-14440 L7 Replaced by Copper, Soldering, KS-14440 L17	"Mfr Disc."
COPPER, SOLDERING, KS-14440 L8 Replaced by Copper, Soldering, KS-14440 L18	"Mfr Disc."
COPPER, SOLDERING, KS-14440 L11 Replaced by Copper, Soldering, KS-14440 L12	"Mfr Disc."
COPPER, SOLDERING, KS-14440 L12 Replaced by Copper, Soldering, KS-14440 L13	"Mfr Disc."

---

**COPPER, SOLDERING, KS-14440**

Word orders for soldering coppers as follows:  
 (Quantity) Copper, Soldering, KS-14440 L (number)

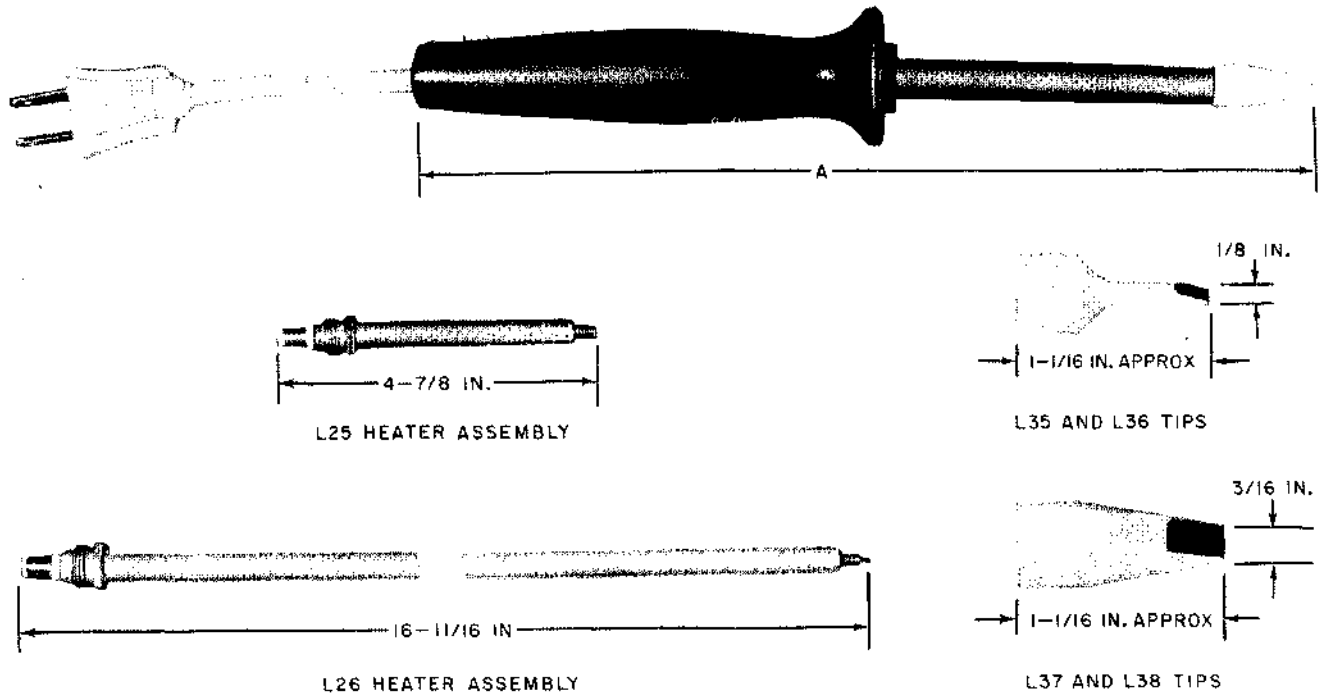

(Illustration 2)

**DESCRIPTION OF KS-14440 SOLDERING COPPERS**

LIST NO.	HEATER ASSEMBLY	TIPS	LENGTH DIM. A	CORD LENGTH	PLUG TYPE
13	26	*	21.5"	20 ft.	Parallel
16	25	*	9.7"	20 ft.	Parallel
17	25	*	9.7"	6 ft.	Parallel
18	25	*	9.7"	6 ft.	3-Prong Gnd

\* L35, L36, L37 and L38 tips must be ordered separately.

Lightweight, 120-volt, 45-watt, quick-heating soldering coppers consisting of a handle, replaceable heater, replaceable threaded tip, and a replaceable cord set. The tip must be ordered separately. Intended for applications where small size, lightweight and quick-heating are desirable or where space limitations make use of the larger KS-8740 soldering copper impracticable or inconvenient.

For soldering copper holders, refer to the 504A tool and the KS-8526 rest.

For piece-part data and maintenance information, see Section 075-191-812.

Soldering Coppers, KS-14440 L16 and L17 are for general use. The L13 is primarily for use on switchboard multiples. The L18 is a grounded soldering copper which is available where it is required. The L18 is not for use in the central office.

**COPPER, SOLDERING, KS-14582 L1**  
 Replaced by KS-14582 L2 Soldering Copper

"Mfr Disc."

**COPPER, SOLDERING, KS-14582 L2** (Furnished with tip which must be specified in the order)

Word orders for soldering coppers as follows:

(Quantity), Copper, Soldering, KS-14582 L2 with list number tip

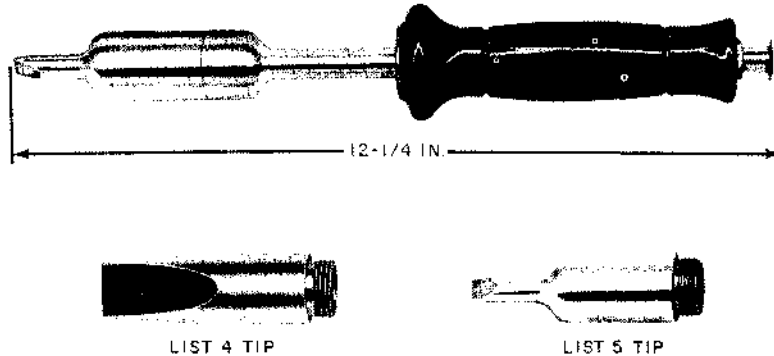

Operates on one KS-14768 Heat Unit. Heat units must be ordered separately in cartons of 12. For information on handling and maintaining the KS-14582 L2 Soldering Copper and using the KS-14768 Heat Unit, refer to Section 075-190-811. For piece-part data refer to Section 075-191-812.

The BR-34 Brush, Kemode Manufacturing Co, for cleaning the tip chamber and threads, is furnished with the soldering copper.

The RM-12 Reamer, Kemode Manufacturing Co, which must be ordered separately, is available for cleaning the body assembly of the copper.

For a soldering copper holder, refer to the 504A tool.

For use where electric power is not available.

**IRON, SOLDERING, KS-16346 L1****IRON, SOLDERING, KS-16346 L2**

In ordering, specify list number desired.

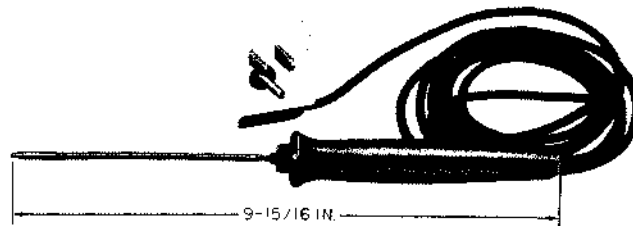

Furnished with Heat Unit, Tip, and KS-16368 L3 Transformer.

LIST NUMBER	LENGTH OF CABLE	HEAT UNIT AND TIP	VOLTS	WEIGHT (including Cable)
1	9 ft.	L31	105/125	2 oz.
2	19 ft.	L32	105/125	3 oz.

Lightweight, miniature 6-volt, quick-heating, soldering irons equipped with cable and 50/60 cycle power transformer. The dimensions and characteristics of the L1 and L2 irons are the same but different tips are used to function with cables of different lengths. The transformer mounts in a standard parallel blade convenience outlet. A removable third prong, used for centering, is provided for mounting in a three-prong outlet.

For piece-part data and maintenance, see Section 075-191-812.

For use in soldering wire wrapped connections.