

INSERTERS
DESCRIPTION
TOOLS

1. GENERAL

1.01 This section describes coded and noncoded inserter tools.

1.02 Revision arrows are used to emphasize significant changes. The reasons for reissue are listed below.

- (a) To add the 756B2, 756C3, 756D2, 963A, and 964A inserter tools
- (b) To add Table A
- (c) To rate KS-16205 and KS-21771 inserter tools Mfr Disc.

1.03 Replacement tools are indicated adjacent to the following tools that have been Mfr Disc.

TOOLS	REPLACEMENT
756B	756B2
756C	756C3
756C2	756C3
756D	756D2
AT-8762B	AT-8762D
KS-16205	—
KS-21771	724A and 756D2

2. DESCRIPTION OF TOOLS

2.01 714B: The 714B wire inserter tool (Fig. 1) is used for making cross-connections on 66-type connecting blocks.

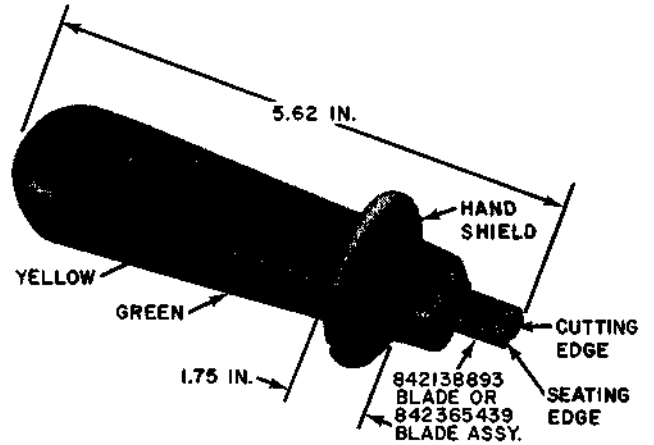

Fig. 1—714B Wire Inserter Tool

2.02 714E2: The 714E2 wire inserter tool (Fig. 2) is used for making cross-connections on the 66G- and 66H-type connecting blocks. The 714E2 tool replaces the 714E tool.

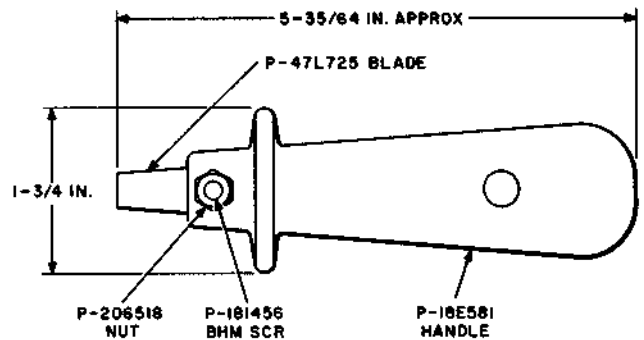

Fig. 2—714E2 Wire Inserter Tool

NOTICE

Not for use or disclosure outside the
AT&T Companies except under written agreement

2.03 756B2: The 756B2 wire inserter tool (Fig. 3) is used for making connections on the 78-type connecting blocks. The 756B2 tool replaces the 756B tool.

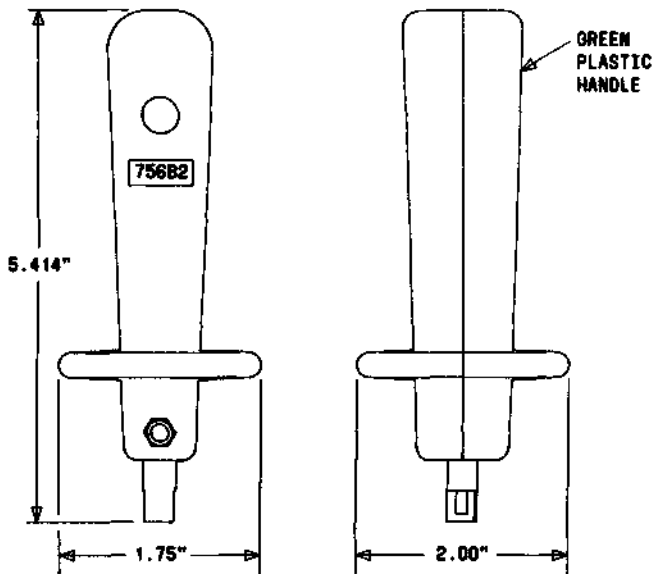

Fig. 3—756B2 Wire Inserter Tool

2.04 756C3: The 756C3 inserter tool (Fig. 4) consists of a light gray plastic handle, an insulated blade, and associated hardware. The blade is provided with wire retention holes, a V-shaped slot on the 3-beam end, and has a black nylon coating to prevent electrical shorting during installation. The 756C3 tool is used for inserting wires into 3-beam and 4-beam terminals on 78- and 112-type connector blocks in the COSMIC^{*} I and II main distributing frames. The 756C3 tool replaces the 756C2 inserter tool.

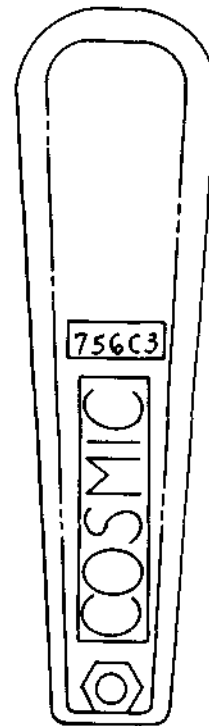

Fig. 4—756C3 Inserter Tool

2.05 756D2: The 756D2 inserter tool (Fig. 5) consists of a plastic handle, an insulated blade, and associated hardware. The tool is used in seating 22 American Wire Gauge (AWG) Irradiated Polyvinyl Chloride (IPVC) wire in both single slip terminals and in quick connect terminals welded assemblies in 78A and 78B connecting blocks on the ESS[†] switching equipment.

* Trademark of Western Electric.

† Trademark of Western Electric.

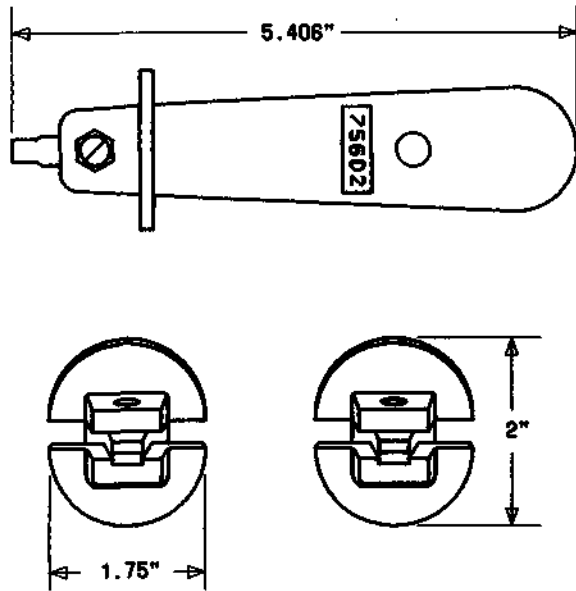

Fig. 5—756D2 Inserter Tool

2.06 788B2: The 788B2 inserter tool (Fig. 6) is used with a 788A1 handle to insert cable pairs on 88-type wiring blocks, one to five pairs at a time. The 788B2 tool is also used to install 88-type connecting blocks on to 88-type wiring blocks.

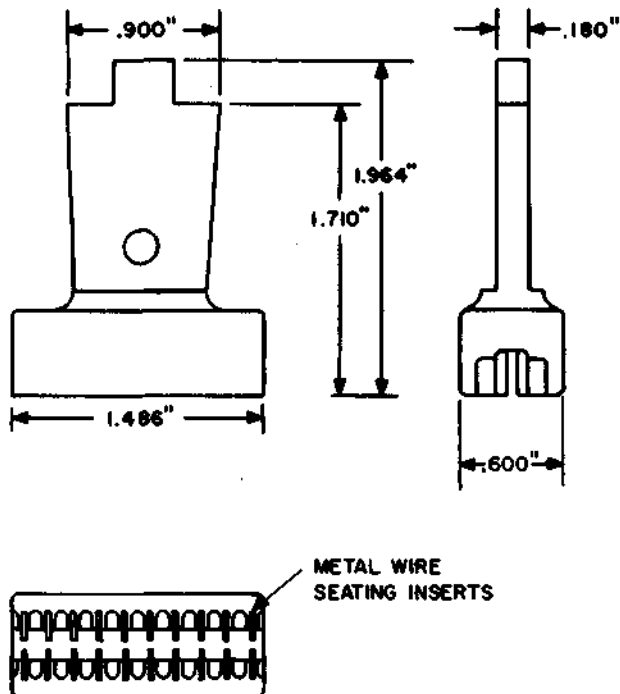

Fig. 6—788B2 Inserter Tool

2.07 788C1: The 788C1 inserter tool (Fig. 7) is used with a 788A1 tool handle. The 788C1 tool is used for inserting and trimming off up to five pairs of conductors at a time while being installed in an 88-type wiring block.

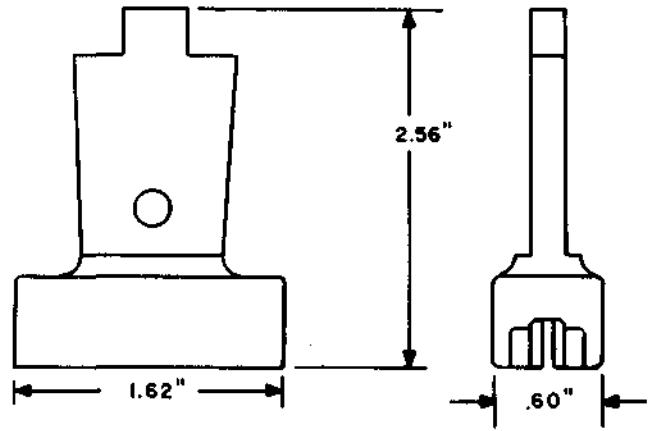

Fig. 7—788C1 Inserter Tool

2.08 788D3: The 788D3 inserter-cutter tool (Fig. 8) consists of a 788A1 tool handle and an insertion head. The 788D3 is a single-pair insertion tool with reversible ends on the head. One end provides insertion cutoff capable of seating and cutting off a pair of 24-gauge F cross-connect wires on the top (jumper) side of an 88-type connecting block. The other end is for insertion only.

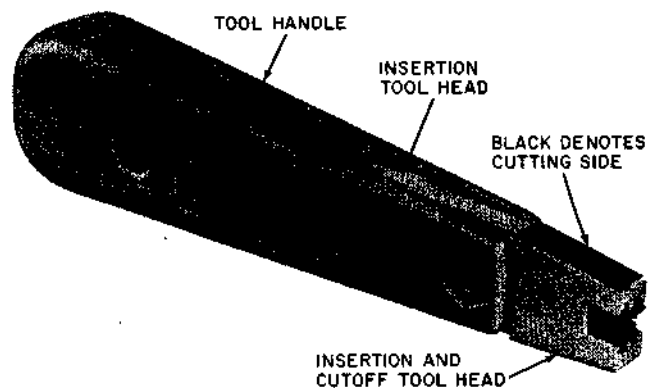

Fig. 8—788D3 Inserter-Cutter Tool

2.09 788J1: The 788J1 spring-loaded impact tool (Fig. 9) is used to install 88-type connecting blocks and to seat, or seat and trim, up to ten conductors.

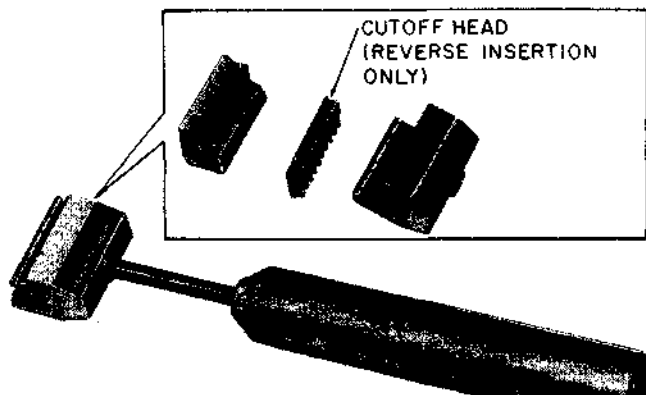

Fig. 9—788J1 Spring-Loaded Impact Tool

2.10 788K1: The 788K1 conductor holder tool (Fig. 10) is used to hold conductors in place on 88-type wiring blocks during the removal of 88-type connector blocks.

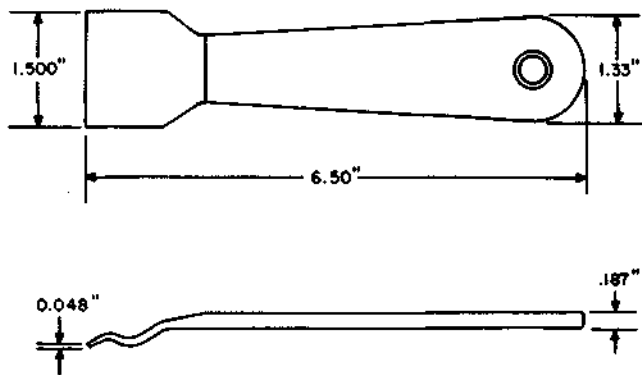
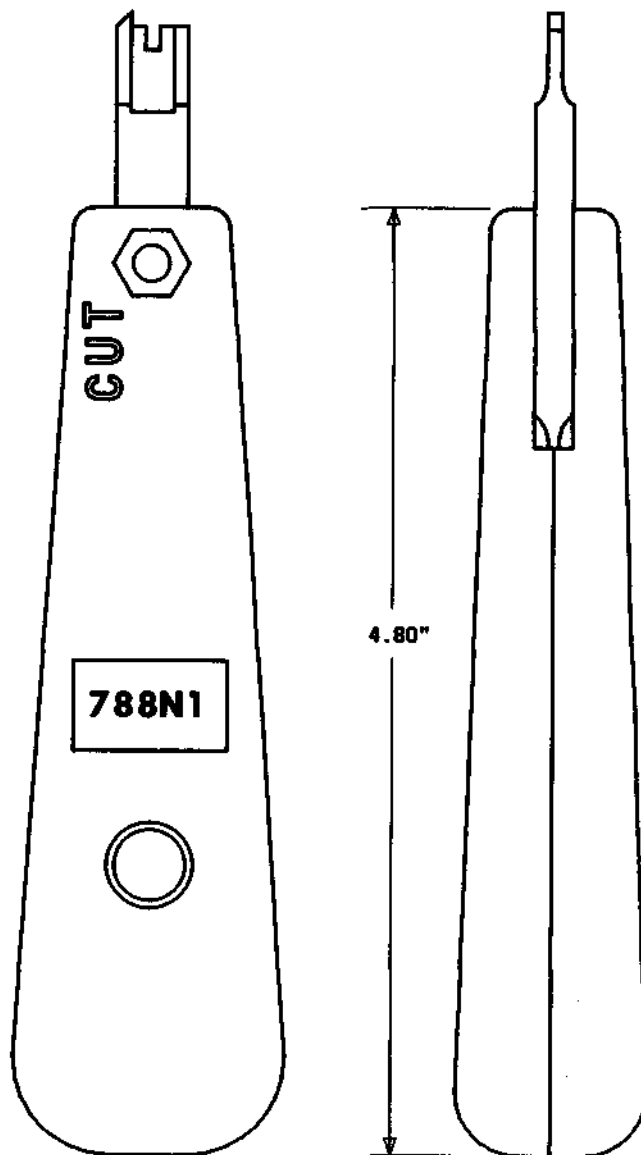

Fig. 10—788K1 Conductor Holder Tool

2.11 788M1: The 788M1 body pressing head assembly tool consists of ten molded metallic wire stuffers and a reversible cutting assembly containing ten metallic cutting elements. When installed in a 788J1 tool, it will seat or seat and trim conductors in an 88-type wiring block. The 788M1 tool may be used to mount 88- or 108-type connecting blocks.

2.12 788N1: The 788N1 reversible blade insertion tool (Fig. 11) consists of a reversible blade mounted in a plastic handle and is used with the 88 and 108 connector systems to terminate jumper wires, one at a time.



◆Fig. 11—788N1 Reversible Blade Insertion Tool◆

2.13 **793A:** The 793A insertion tool (Fig. 12) is used for insertion and removal of all paddle boards.

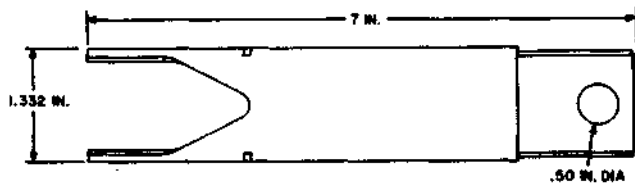

Fig. 12—793A Insertion Tool

2.14 **797A:** The 797A double-ended plastic lead insertion tool (Fig. 13) is used with the 788A1 tool (handle). This tool is used in wiring of the 630A jack phone center. The 797A tool seats and inserts, but does not trim insulated station wire conductors.

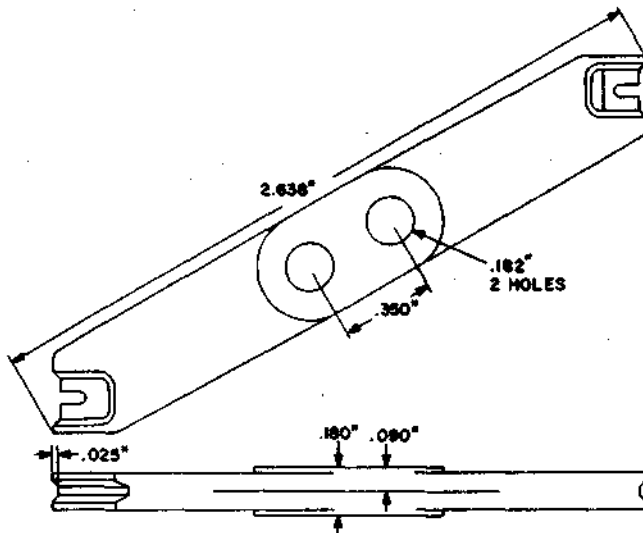

Fig. 13—797A Insertion Tool

2.15 **821A:** The 821A insertion tool (Fig. 14) is used to insert and remove the P-11F667 fuse cap of the modular-type fuse blocks where equipped with a neoprene washer.

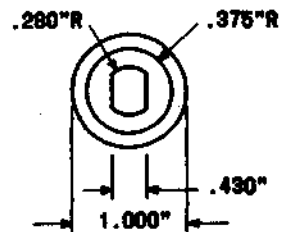
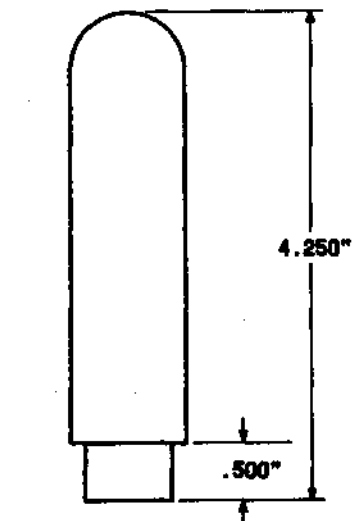

Fig. 14—821A Insertion Tool

2.16 **833A:** The 833A insertion and cutoff tool (Fig. 15) is used to insert and cut off 22-gauge wire on the jumper side of the 93 series connecting blocks.

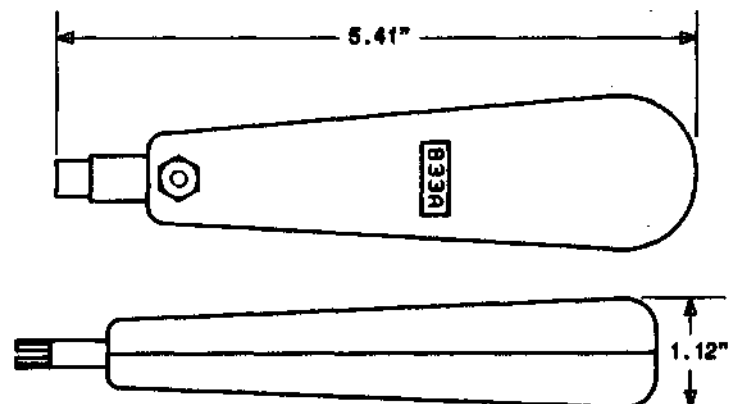

Fig. 15—833A Insertion and Cutoff Tool

2.17 834A: The 834A polarized wire stuffer and cutoff tool is used to seat and cut ten, 22-gauge polyvinyl chloride conductors mounted in an index strip on the 93-type connecting blocks. The 834A tool is used with the 834B tool.

2.18 834B: The 834B insertion and cutoff tool (Fig. 16) consists of an impact handle and 834A tool. The 834B tool is used to seat and cut ten, 22-gauge polyvinyl chloride conductors mounted in an index strip on the 93-type connecting blocks with one impact.

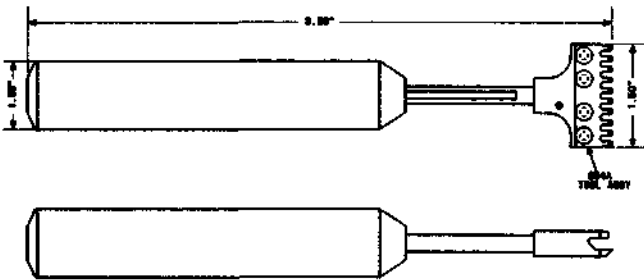

Fig. 16—834B Insertion and Cutoff Tool

2.19 872A: The 872A insertion tool (Fig. 17) consists of a flexible, restrictive and nonrestrictive blade. It is used to correct faulty 78-type terminals in the COSMIC main distributing frame.

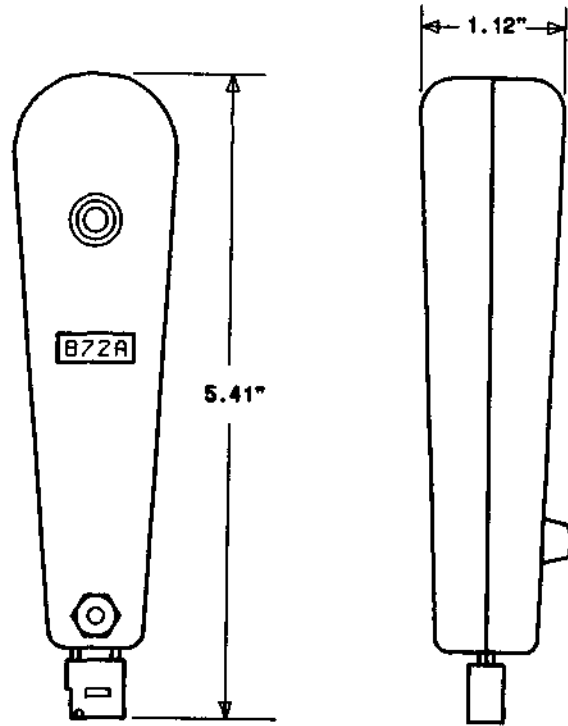

Fig. 17—872A Insertion Tool

2.20 950A: The 950A jumper wire cutoff, insertion, and removal tool (Fig. 18) is used on the COSMIC I and II main distributing frames. One insertion end (identified by the red dot) is used for inserting DT24P jumper into the 4-beam clips of the 78C blocks. The other end (identified by the blue dot) inserts DT24P wire into the 3-beam clips of the 112C blocks.

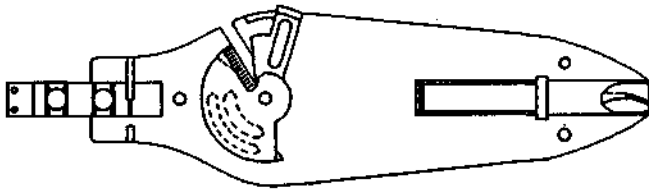

Fig. 18—950A Jumper Wire Cutoff, Insertion, and Removal Tool

2.21 **954A:** The 954A wire and cable insertion tool (Fig. 19) is designed to push wire or cable leads into the index strip to the front of the 93 series connecting blocks prior to impacting them with the 834B insertion and cutoff tool.

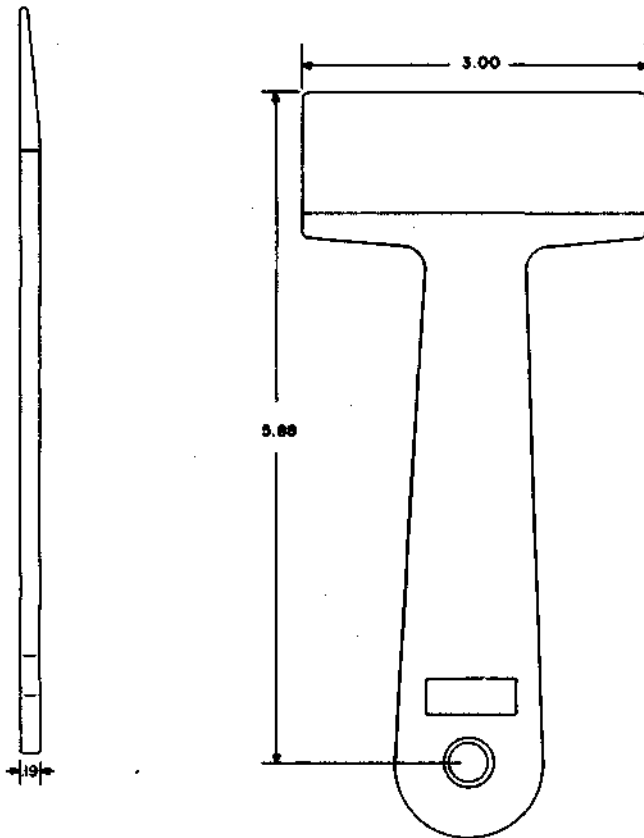

Fig. 19—954A Wire and Cable Insertion Tool

2.22 **963A:** The 963A insertion tool (Fig. 20) is used for inserting straight-type spade lug receptacles such as AMP[®] 250 series FASTON[®] onto 221B and 221C terminals.

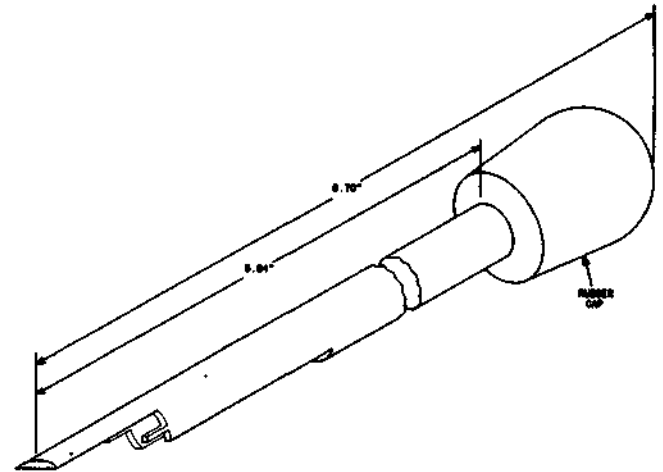

Fig. 20—963A Insertion Tool

2.23 **964A:** The 964A insertion tool (Fig. 21) is used for inserting flag-type spade lug receptables such as AMP 250 series FASTON onto 221B and C terminals.

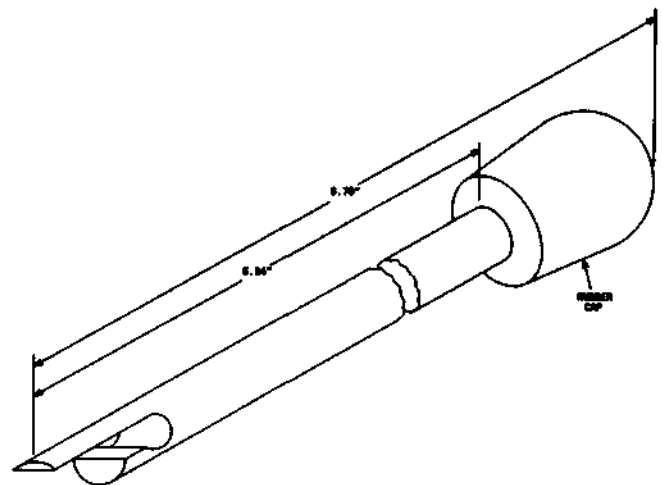

Fig. 21—964A Insertion Tool

* Trademark of AMP Corporation.

2.24 R-4710: The R-4710 C impact tool (Fig. 22) has an impact force in the range of 18 to 21 pounds. The available blades are 4710 and 4710A. The 4710 blade is used to seat wire ends. The 4710A blade is used to seat and cut off wire ends. This tool is used for terminating wires in the 94-type connecting block.

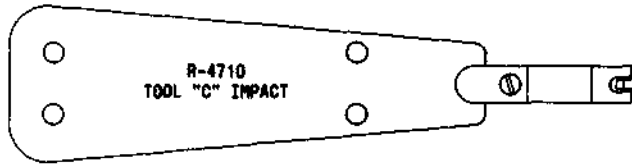

Fig. 22—R-4710 C Impact Tool

2.25 R-4710A: The R-4710A C impact tool (Fig. 23) has an impact force in the range of 25 to 33 pounds. The available blades are 4710 and 4710A. The 4710 blade is used to seat wires. The 4710A blade is used to seat and cut off wire ends. This tool is used for terminating wires in the 94-type connecting block.

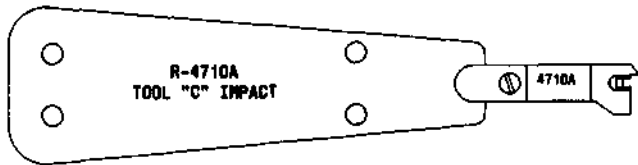
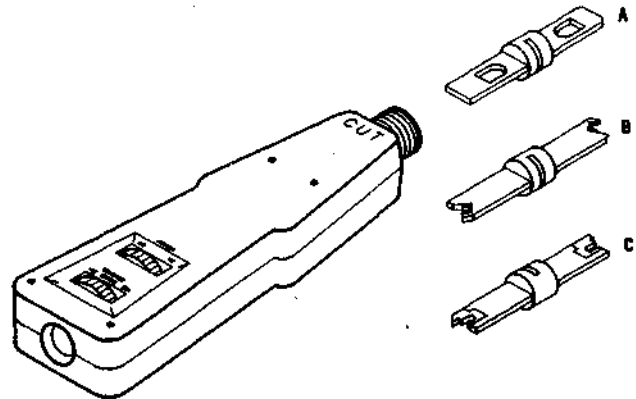

Fig. 23—R-4710A C Impact Tool

2.26 AT-8762D: The AT-8762D impact tool (Fig. 24) consists of an impact handle and three attachment blades used for terminating wires onto bifurcated terminals. The tapered plastic handle contains a spring impact mechanism for a high or low impacting force as well as a storage compartment for a spare blade. The blades that are used are as follows:

- (a) **66:** The 66 blade is used for 66-type connecting blocks.
- (b) **88:** The 88 blade is used for connecting wires to 88-, 108-, 109- and 110-type connecting blocks.

(c) **630:** The 630 blade is used for connecting wires to 630A jacks.



LOC	BLADE NO. 8762D-
A	66
B	630
C	88

Fig. 24—AT-8762D Impact Tool

2.27 AT-8764: The AT-8764 insertion cutter tool (Fig. 25) is used in splicing, one pair at a time, in both the old and new 710 connectors.

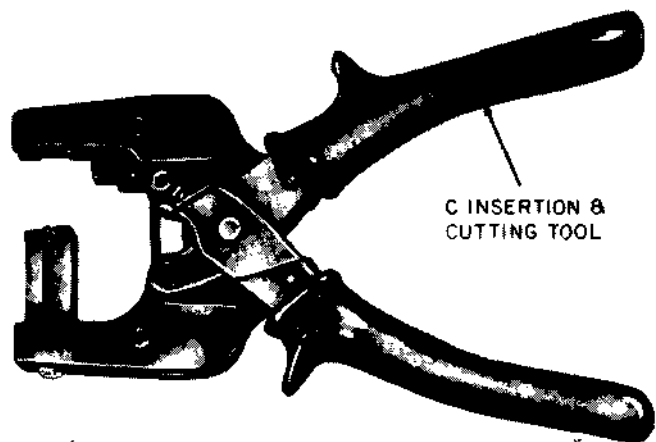

Fig. 25—AT-8764 Insertion Cutter Tool

2.28 KS-14553: The KS-14553 card inserter tool (Fig. 26) is used to insert single-coded cards in 1-type translators.

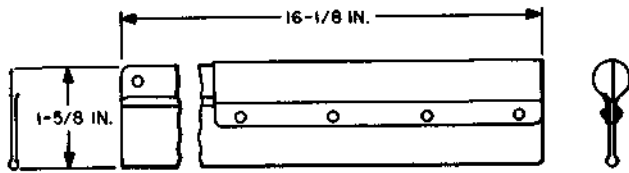

Fig. 26—KS-14553 Card Inserter Tool

2.29 KS-16748, L1: The KS-16748, L1, insertion tool (Fig. 27) is used in replacing solderless-wrap terminals in cast resin terminal strips.

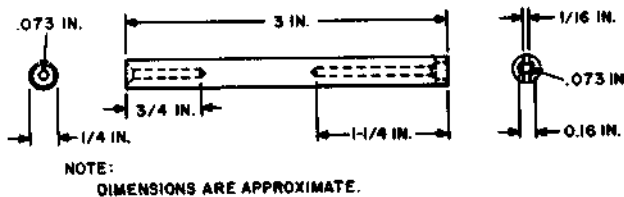

Fig. 27—KS-16748, L1, Insertion Tool

2.30 KS-19092, L1: The KS-19092, L1, inserting and extracting tool (Fig. 28) is used with 24-gauge strap wire on wedge terminals of printed circuits.

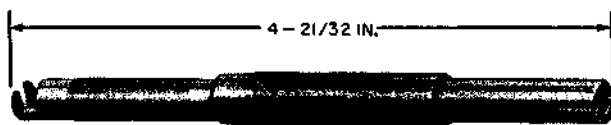

Fig. 28—KS-19092, L1, Insertion and Extracting Tool

2.31 KS-21873, L1: The KS-21873, L1, inserting guide bushing tool (Fig. 29) is used with the 440-type coaxial plugs.

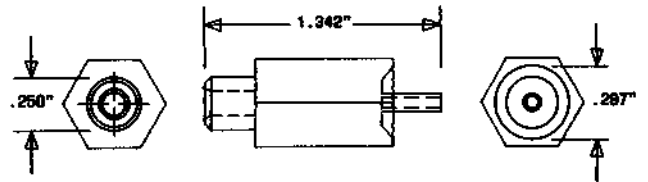

Fig. 29—KS-21873, L1, Inserting Guide Bushing Tool

2.32 KS-21873, L2: The KS-21873, L2, inserting guide bushing tool (Fig. 30) is used with the 358-type coaxial plugs.

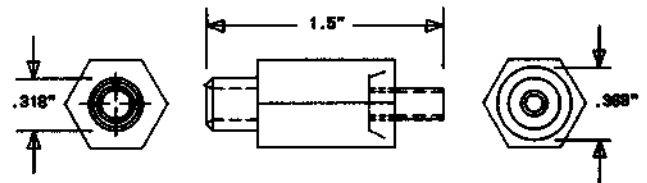

Fig. 30—KS-21873, L2, Inserting Guide Bushing Tool

2.33 KS-22386, L1: The KS-22386, L1, cap inserter tool (Fig. 31) is used to install shielding caps on right angle, miniature coaxial connectors similar to KS-20864, L3 and L4.

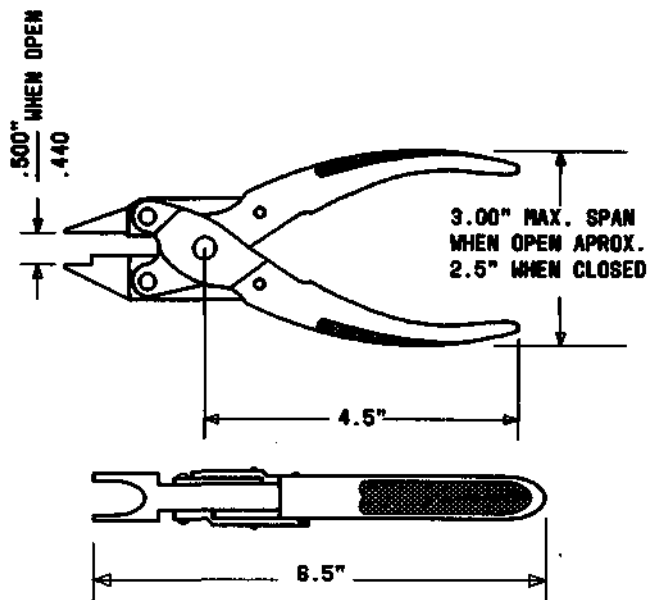

Fig. 31—KS-22386, L1, Cap Inserter Tool

2.34 HELI-COIL® Corp Inserting Tool: The HELI-COIL Corp inserting tool (Fig. 32) is used for HELI-COIL inserts. In ordering, specify number of tool desired. This tool is used on the KS-13835 reader, and the inserts (Table A) must be ordered separately.

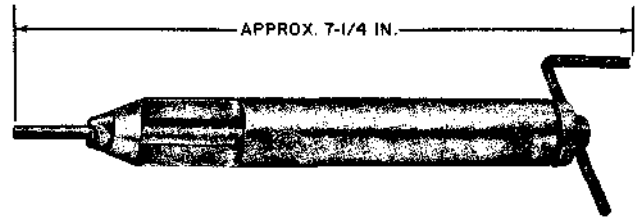

Fig. 32—HELI-COIL Corp Inserting Tool

TABLE A

HELI-COIL INSERTER INSERTS

TOOL NUMBER	INSERTS USED WITH TOOL	THREAD SIZES
528-2N	1185-2CN	8-32
535-3N	1191-3CN	10-32
535-4N	1191-4CN	1/4-28
535-5N	1191-5CN	5/16-24

* Registered Trademark of Heli-Coil Corporation.