

## CIRCUIT SCHEMATIC DRAWINGS (SDs) DESCRIPTIVE INFORMATION

CONTENTS	PAGE	CONTENTS	PAGE
1. GENERAL . . . . .	3	5. FUNCTIONAL SCHEMATICS . . . . .	11
2. EVOLUTION OF THE SD- DRAWING . . . . .	4	6. APPARATUS FIGURES . . . . .	12
DETACHED CONTACT SCHEMATICS . . . . .	4	A. General . . . . .	12
A. Circuit Pack and Circuit Module Schematics . . . . .	5	B. Circuit Packs . . . . .	12
B. Sectionalized and Nonsectionalized SDs . . . . .	5	C. Relays . . . . .	13
C. "O&M" and "E&M Only" Partitioning . . . . .	5	Wire-Spring Relays . . . . .	14
3. ARRANGEMENT OF INFORMATION ON SD- DRAWINGS . . . . .	5	Dry Reed Relays . . . . .	14
A. General . . . . .	5	Mercury Contact Relays . . . . .	15
B. Sectionalized Drawings (Prepared Prior to September 1, 1980) . . . . .	6	Flat-Spring Relays . . . . .	15
C. Sectionalized Drawings (Prepared After September 1, 1980) . . . . .	6	General Relay Tabular Form . . . . .	15
D. Sectionalized Drawings (Common Practices) . . . . .	7	Individual Relays . . . . .	15
E. Nonsectionalized Drawings . . . . .	8	D. Capacitors . . . . .	15
4. INDEXES AND SUPPORTING INFORMATION . . . . .	9	E. Component Assemblies . . . . .	15
A. Sheet Index . . . . .	9	F. Connectors . . . . .	16
B. Supporting Information . . . . .	9	G. Cords . . . . .	16
C. Apparatus Index . . . . .	9	H. Diodes, Fuses, and Inductors . . . . .	16
D. Lead Index . . . . .	10	I. Jacks . . . . .	16
E. Option Index . . . . .	10	J. Keys and Keytops . . . . .	16
F. Designation Mnemonic Index . . . . .	11	K. Lamps and Networks . . . . .	17
		L. Outlets and Receptacles . . . . .	17
		M. Plugs . . . . .	17
		N. Potentiometers, Rectifiers, and Regulators . . . . .	17

CONTENTS	PAGE	CONTENTS	PAGE
O. Resistors . . . . .	17	<b>FIGURES</b>	
P. Selectors . . . . .	17	1A. Sheet Index for Drawings Arranged for Individual Sheet Reissue Prior to September 1, 1980 . . . . .	31
Q. Switches . . . . .	18	1B. Sheet Index for Drawings Arranged for Individual Sheet Reissue After September 1, 1980 . . . . .	31
R. Switchtops . . . . .	18	1C. Sheet Index Not Arranged for Individual Sheet Reissue . . . . .	31
S. Thermistors, Transformers, Transistors, Tubes, and Varistors . . . . .	18	1D. Supporting Information Table . . . . .	31
T. Other Components . . . . .	18	2A. Apparatus Index . . . . .	32
<b>7. NOTES AND GENERAL CIRCUIT INFORMATION . . . . .</b>	<b>18</b>	2B. Lead Index Connecting Circuits Table . . . . .	32
A. Circuit Notes . . . . .	18	2C. Lead Index . . . . .	32
B. Equipment Notes . . . . .	19	2D. Option Index . . . . .	32
C. Information Notes . . . . .	19	3. Designation Mnemonic Index . . . . .	32
D. Cross-Connection Information . . . . .	20	4. Functional Schematic — Methods of Showing Information . . . . .	33
E. Transmission Test Requirements Table . . . . .	21	5. Methods of Showing Information in Apparatus Figures . . . . .	39
F. Working Limits Table . . . . .	21	5A. Basic Table Format . . . . .	39
<b>8. SEQUENCE CHARTS . . . . .</b>	<b>21</b>	5B. Simplified Format . . . . .	39
<b>9. CIRCUIT REQUIREMENTS TABLES . . . . .</b>	<b>22</b>	5C. Elementized Circuit Pack Format . . . . .	39
<b>10. TIMING REQUIREMENTS TABLES . . . . .</b>	<b>22</b>	5D. Method of Showing Wire-Spring Relays . . . . .	39
<b>11. CABLING DIAGRAMS . . . . .</b>	<b>22</b>	5E. Method of Showing Multicontact Wire Spring Relays . . . . .	40
<b>12. BLOCK DIAGRAMS . . . . .</b>	<b>23</b>	5F. Alternative Method of Showing Dry Reeds. . . . .	40
<b>13. CIRCUIT PACK SCHEMATICS ON AN SD . . . . .</b>	<b>24</b>	5G. Alternative Method of Showing Dry Reeds. . . . .	40
<b>14. CIRCUIT MODULE SCHEMATICS ON AN SD . . . . .</b>	<b>26</b>	5H. Alternative Method of Showing Dry Reeds. . . . .	40
<b>15. LOCATING INFORMATION ON THE DRAWING . . . . .</b>	<b>26</b>	5I. Method of Showing Mercury Contact Relays . . . . .	40
<b>16. CIRCUIT DESCRIPTIONS . . . . .</b>	<b>27</b>		
REASONS FOR REISSUE . . . . .	28		

CONTENTS	PAGE
5J. Method of Showing Flat-Spring Relays . . . . .	40
5K. General . . . . .	41
5L. Method of Showing Individual Relays . . . . .	41
5M. Method of Showing Capacitors . . . . .	41
5N. Method of Showing Keys and Keypops . . . . .	42
5P. Basic Tabular Form of Listing Information . . . . .	43
6. Fusing Note . . . . .	44
7. Feature or Option Table . . . . .	44
8. Record of Changes Table . . . . .	44
9. Network Values Table . . . . .	44
10. Transmission Test Requirements Table . . . . .	44
11. Working Limits Table . . . . .	44
12. Sequence Chart Method of Showing Information . . . . .	45
13. Sequence Chart Index of Operate and Release Location . . . . .	47
14. Circuit Requirement Table . . . . .	48
15. Timing Requirement Table . . . . .	48
16. Methods of Showing Information in Cabling Diagrams . . . . .	49
17A. Circuit Block Diagram . . . . .	50
17B. Functional Schematic Block Diagram . . . . .	51
17C. System Block Diagram . . . . .	52
17D. System Application Diagram . . . . .	53
18. Schematic Diagram Method of Showing Circuit Packs . . . . .	54

**TABLES**

CONTENTS	PAGE
<b>A. ARRANGEMENT OF INFORMATION ON SECTIONALIZED DRAWINGS (PRIOR TO SEPTEMBER 1, 1980)</b> . . . . .	<b>6</b>
<b>B. PARTITIONING OF "E&amp;M" ONLY "O&amp;M" INFORMATION ON AN SD (AFTER SEPTEMBER 1, 1980)</b> . . . . .	<b>6</b>
<b>C. ARRANGEMENT OF INFORMATION ON NONSECTIONALIZED DRAWINGS</b> . . . . .	<b>8</b>

**1. GENERAL**

1.01 This BSP describes a type of circuit drawing issued by Bell Telephone Laboratories, Incorporated. These drawings document mainly electromechanical and non-ESS-type electronic circuits of units, frames, and systems. (Information pertaining to circuit drawings for ESS-type circuits may be found in Section 005-111-101.) The drawings have evolved into a format commonly called detached-contact circuit schematic drawings. They are identified by an SD- prefix followed by a 5-character number, a hyphen, and an engineering requirements suffix, eg, SD-6G125-01.

1.02 This BSP has been reissued to agree with the latest BTL practices. This includes major changes and additions to the text and illustrations. Since this is a general revision, arrows are not used to indicate changes. Detailed information concerning the changes can be found at the end of this BSP under REASONS FOR REISSUE.

1.03 An SD- drawing and its Circuit Description (described in Section 16) are the basic design control documents for equipment and systems. A circuit schematic represents all interconnected apparatus in the equipment or system, and contains notes that explain features, options, and critical conditions. An entire system may be represented by a group of SDs. These drawings have three main uses:

- (a) Used by Western Electric as the basis for the preparation of T (wiring) and J (assembly) drawings.

## SECTION 005-109-101

- (b) Used by Western Electric and the operating companies for central office engineering, installation, and testing of equipment and systems.
- (c) Used by operating companies to operate and maintain circuits and to train personnel.

**1.04** The figures in this BSP are located at the end. The configurations, charts, tables, and indexes illustrated in these figures are typical and do not represent a particular drawing.

### 2. EVOLUTION OF THE SD- DRAWING

**2.01** Since about 1928, SD- drawings have been prepared in "attached" form. That is, the individual relays, jacks, keys, coils, tubes, etc, which, when properly wired together, constitute a circuit, were shown on the SD as complete physical units. Because many of these apparatus items consisted of separate parts (contacts) used to perform multiple functions in the circuit, it was necessary to show the circuit paths going back and forth between the separate parts. This method of presenting the circuit was generally satisfactory for the types of circuits then in use. However, with the gradual replacement of manual switching systems by more and more complex dial switching systems, effectively presenting the circuit information on SD- drawings became difficult. Sometimes understanding the circuit and tracing circuit paths was complicated by having to follow the action of the circuit through many parallel and crossing lines that frequently extended over several sheets. With the introduction of common control switching systems and automatic message accounting, devising a different method of presenting circuits became imperative. Thousands of individual relays, tubes, and other apparatus comprised some of the complex circuits. Under such conditions, the presentation, understanding, and use of the circuit information was difficult. The detached-contact SD has been devised as a simpler and more effective means of presenting switching systems circuit information.

#### DETACHED-CONTACT SCHEMATICS

**2.02** Since the early 1950s, SD- drawings have been prepared in "detached-contact" form. The information presented on these schematic drawings is separated into groups, each presenting similar information. Cross-referencing between the groups coordinates the information. Extensive indexes on the first page or pages of the drawings help locate individual items of information in any group.

**2.03** On a detached-contact SD- drawing, the circuit paths emphasize the functions performed by the circuit. The circuit paths are shown on a series of Functional Schematics (FSs) constituting one group of the drawing. Each FS represents a function or a related group of functions and shows the complete functional paths of all pertinent relays and apparatus. In general, all circuit paths are shown complete from battery to ground, even though this may require duplicating information shown in other FSs or other circuits. External circuit information is shown in sufficient detail to give meaning to the function path.

**2.04** To achieve the objectives of an FS, relays, jacks, keys, switches, and other apparatus having parts that perform separate operations are shown in a "detached" manner. For example, relay contacts are shown directly associated with their functional path and not in physical relation to the relay coil that operates them. In this sense, the relay contacts are "detached" from their operating coil. Thus, detached-contact schematics are fundamentally different from attached-contact schematics, which emphasized physical apparatus grouping.

**2.05** The individual parts of a given relay, jack, key, or other component in a circuit may perform different functions. As a result, the individual parts may be shown on numerous FSs of the circuit. This requires a means to readily associate the detached parts with each other. This is done by showing all parts of each piece of apparatus together in one place in another group of the drawing called Apparatus Figures (APP FIGs). In addition to showing each apparatus item in its physical arrangement, APP FIGs indicate where all the parts of each apparatus item are shown on the FSs of the circuit. Also, the APP FIG gives the code number of each apparatus item and the quantity required. When the apparatus item is available in a variety of values, the required value is given. An APP FIG, therefore, indicates complete information for ordering all the individual apparatus items included in a coded unit (J code).

**2.06** To clarify the circuit, another group of information known as Sequence Charts (SCs) is usually included as part of the drawing. SCs for electromechanical circuitry show the time order (sequence) of operation and release of the relays, switches, and other electromagnetic and electronic devices as they perform their various functions in the circuit. SCs for electronic circuitry show flow or data

or signals occurring from one functional unit (register, bus, adder, etc) to another, from one location in a circuit to another, and between connecting circuits when required. The SCs provide a *diagrammatic representation* of the sequence or circuitry interconnections needed to carry out the flow or data for a given order of operations.

**2.07** In addition to the indexes and the three major groups of circuit information (FSSs, APP FIGs, and SCs) just described, other information required to complete the circuit story is contained in notes, cabling diagrams, circuit requirements, and block diagrams. These groups are all auxiliary to the three major groups of circuit information.

#### A. Circuit Pack and Circuit Module Schematics

**2.08** As a result of printed wiring board (PWB) technology introduced in the early 1960s, two additional groups of information were added to the SD- drawing. The new groups of information documented the components and their interconnection on PWBs of Circuit Packs (CPs) and Circuit Modules (CMs). CPs are generally plug-in devices that connect directly to the backplane of a frame, bay, or equivalent. CMs do not directly access the backplane and are mounted on CPs or other CMs.

#### B. Sectionalized and Nonsectionalized SDs

**2.09** Until late 1980, SD- drawing groups were arranged in sectionalized or nonsectionalized formats depending on certain requirements. Nonsectionalized drawing sheets were numbered consecutively beginning with 1 and the groups of information were arranged as covered in detail in Part 2. Sectionalized drawings separated the groups into a separate section for each group of information. The sections were lettered alphabetically beginning with A, as covered in detail in Part 2.

#### C. "O&M" and "E&M Only" Partitioning

**2.10** In September 1980, a further partitioning of the SD- drawing was introduced, and nonsectionalized drawings were no longer prepared. To allow for selective distribution, the SD- drawing is now arranged to identify SD information required to perform operations and maintenance functions. To accomplish this the SD information is partitioned into two separate categories:

(a) *Operation and Maintenance (O&M)*: The O&M information is the base level information required to operate and maintain a circuit by level 1 craft or equivalent. The O&M category does not contain proprietary information or other information required only for engineering and manufacturing. "O&M" information is placed in drawing sections identified by a '#' symbol appended to the basic drawing section letter, ie, A#1, B#5, D#2, etc.

(b) *Engineering and Manufacturing Only (E&M Only)*: The E&M Only category consists of all remaining information that does *not* fit the O&M category; ie, that information required for engineering and manufacturing functions only.

"E&M Only" information is placed in drawing sections *not* having a '#' symbol, ie, A1, D1, etc.

**2.11** Presently all new and redrawn drawings are prepared using this method of partitioning. Section 3 explains the format for the information associated with sectionalized and nonsectionalized SD-drawings. The remaining parts of this BSP explain the contents of each section or group of information.

### 3. ARRANGEMENT OF INFORMATION ON SD- DRAWINGS

#### A. General

**3.01** *Requirements for a Sectionalized or Nonsectionalized SD*: Reference is made in this BSP to sectionalized and nonsectionalized drawings. All new or completely redrawn SDs issued on or after September 1, 1980, are sectionalized. Drawings issued prior to that date are sectionalized if they contain three or more sheets of Functional Schematics (FSSs) or if they contain 30 or more relays each having a different functional designation. Drawings that did not meet either of these conditions usually had been prepared as nonsectionalized drawings. A complete description of both sectionalized and nonsectionalized drawings is explained in Sections B, C, and D.

**3.02** *Size of SD Forms*: All sheets of both sectionalized and nonsectionalized SDs are drafted on mylar forms measuring 22 by 34 inches or COM equivalent. All sheets are reduced to 11 by 17 inches when printed for field use.

**3.03 Accessory Information on All SD Sheets:**

The drawing number, sheet number, complete title, rating, issue number, distribution code, CLEI code, equipment designation, and replacement information (if any) are shown in the lower right corner of the first sheet forms of the drawing. The second sheet forms show the drawing number, sheet number, issue number, and the title of the specific circuit (rather than the title of the whole system) in the lower right corner.

**3.04 Numbering of Sheets:** The method of numbering the sheets and arranging the circuit information differs for sectionalized and nonsectionalized drawings. These differences are explained below in Sections B, C, and D.

**3.05 Reference to Sheet Notes:** Occasionally the statement SEE NOTE, followed by the numbers 1, 2, etc, is shown on a sheet of the drawing. These refer to sheet notes located somewhere on the sheet. These notes are numbered in sequence starting with note 1 on each sheet and clarify circuit information on the sheet.

**3.06 Reference to Tables:** Like notes, tables supplement other information on the drawing. Tables are lettered in sequence from A through Z on each sheet. They are located on the sheet on which they are referenced.

**B. Sectionalized Drawings (Prepared Prior to September 1, 1980)**

**3.07 Format of Sectionalized Drawings:** The information presented on a sectionalized drawing is arranged in clearly separated sections for each group of information. An SD may have up to 10 sections, designated alphabetically from A through K (omitting the letter I). Table A lists all the possible sections and their type of information for SDs initially prepared or issued (Issue 1) prior to September 1, 1980. Sections A, B, C, and D were always required, with the remaining sections provided as required. For SDs initially prepared or issued subsequent to that date, see Table B in 3.08.

**C. Sectionalized Drawings (Prepared After September 1, 1980)**

**3.08 Format of Sectionalized Drawings With O&M and E&M Only Partitioning:** Each group of information on a sectionalized drawing is clearly separated. Certain sections, in part or in

TABLE A

**ARRANGEMENT OF INFORMATION ON SECTIONALIZED DRAWINGS (PRIOR TO SEPTEMBER 1, 1980)**

SECTION	CONTENTS
A	Sheet Index Supporting Information Apparatus Index Lead Index Option Index Designation Mnemonic Index
B	Functional Schematics (FS)
C	Apparatus Figures (APP FIG)
D	Circuit Notes (100 Series) Equipment Notes (200 Series) Information Notes (300 Series) Cross-Connecting Information Notes (400 Series) Transmission Test Requirements Table Working Limits Information
E	Sequence Charts (SC)
F	Circuit Requirements Table (CRT) Timing Requirements Table (TRT)
G	Cabling Diagrams (CAD)
H	Block Diagrams (BD)
J	Circuit Pack Schematics (CPS)
K	Circuit Module Schematics (CMS)

total, have the "O&M" information completely distinguished from the "E&M Only" information (defined in paragraph 2.10) by a '#' symbol following the section letter. Table B lists all the possible sections and the type of information each section contains for SDs prepared after September 1, 1980. Sections A, A#, B#, C#, D and D# are always required. The remaining sections are provided as required.

TABLE B

**PARTITIONING OF "E&M" ONLY "O&M"  
INFORMATION ON AN SD  
(AFTER SEPTEMBER 1, 1980)**

SECTION	CONTENTS
A	Sheet Index Supporting Information Option Index
A#	Sheet Index (for O&M only) Apparatus Index Lead Index Designation Mnemonic Index
B#	Functional Schematics (FS)
TABLE B (Contd)	
C#	Apparatus Figures (APP FIG)
D	Circuit Notes: 101. Fusing Note 102. Network Values Table 103.199. Miscellaneous Notes (Transformer Option Note, Working Limits, Tripping Ranges, etc)  Equipment Notes (200 Series)
D#	Information Notes: 301. UNLESS OTHERWISE SPECIFIED...note 302. Feature and Option Table 303. Record of Changes Table 304-399. Miscellaneous Notes (Transmission Test Requirements, Electrolytic Capacitor Test Requirements, etc)
E#	Sequence Charts (SC)
F#	Circuit Requirements Table (CRT) Timing Requirements Table (TRT)
G	Cabling Diagrams (CAD) (Section G and G# are mutually exclusive and Section G is usually provided)
G#	Cabling Diagrams (CAD) (Only when wiring information such as T drawings will not be available)

## SECTION CONTENTS

H#	Block Diagrams (BD)
J	Circuit Pack Schematics (CPS)
K	Circuit Module Schematics (CMS)

**D. Sectionalized Drawings (Common Practices)**

**3.09 Missing Sections on an SD:** The contents of each section listed in Table A and Table B are described in this BSP beginning with paragraph 5.01. Some circuit drawings may not include one or more of the sections listed. For example, if SCs are not required on a drawing, the E (or E#) section will be omitted.

**3.10 Numbering of Sheets:** The sheets in each section are numbered in sequence beginning with Sheet 1. The section letter and sheet number are shown on each sheet as a suffix to the drawing number. For example, on SD-27827-01-A2, the A2 indicates Section A, Sheet 2, and on SD-12345-01-B#3, the B#3 indicates Section B#, Sheet 3. When more than one sheet is required to document a Circuit Pack Schematic (CPS) in the J section of the SD, or a Circuit Module Schematic (CMS) in the K section, all sheets for a particular code are assigned the same sheet number but have different lettered suffixes beginning with the letter A. For example, if the CPS for a single code required three sheets, the sheets would be numbered J1A, J1B, and J1C.

**3.11 Inserted Sheet:** On some reissued drawings, a new sheet of information must be added between two existing sheets in a section. Rather than renumber all the sheets, a sheet may be inserted. The letter A is added to the sheet number of the sheet immediately preceding the inserted sheets. The inserted sheets will have the same sheet numbers as the sheet with the A suffix preceding them, but their suffix letters will be assigned alphabetically beginning with B. For example, if two sheets must be inserted between sheets B#10 and B#11, B#10 becomes B#10A, and the new sheets become B#10B and B#10C.

**3.12 Sheet Coordinates:** For ease of reference, sheet coordinates are furnished on all SD sheets except those in the A, A#, and F# sections. The two systems of coordinates used are as follows:

(a) **Sheets in the B#, C#, D, D#, G, G#, H#, J, and K Sections:** This coordinate system uses numbers beginning with 0, evenly spaced, read from left to right along the top and bottom edges of the sheet. Also used are letters beginning with A, evenly spaced, read from top to bottom along the left and right edges of the sheet.

(b) **Sheets in the E# Section:** This coordinate system uses numbers beginning with 1, evenly spaced, read from top to bottom along the left and right edges of the sheet. Also used are letters beginning with A, evenly spaced, read from left to right along the top and bottom edges of the sheet.

**3.13 Specifying Coordinate Locations:** The sheet coordinate information defined in paragraph 3.12 is used to locate components, connections, etc, within the drawing. The coordinate information consists of the sheet number, a letter coordinate, and a number coordinate. Within a section, the section letter is understood and is omitted from the coordinate location. For example, a coordinate location such as 7H5 referred to in the B# section means Sheet B#7 (the B# is understood), letter coordinate H, and number coordinate 5. Coordinate location 3AA10 referred to in the E# section means Sheet E#3 (the E# is understood), letter coordinate AA, and number coordinate 10. When references are made from one section to another, section letters are shown; however, if a column heading is indicative of a section, the section letter is omitted from the coordinate location. When referencing locations on inserted sheets such as B#10A, or on J or K sheets such as J2A or K2B, a slash (/) separates the sheet number from the letter and number coordinates of the sheet, eg, B#10A/C5 or J2A/A4.

#### E. Nonsectionalized Drawings

**3.14 Limited Existence:** As of September 1, 1980, all new or completely redrawn SDs are sectionalized. Therefore, the only nonsectionalized drawings are those that existed prior to that date.

**3.15 Numbering of Sheets:** All sheets of nonsectionalized drawings are numbered in sequence beginning with Sheet 1. The sheet number is shown as a suffix to the drawing number. For example, on SD-27872-01-4, the number 4 represents Sheet 4.

**3.16 Sheet Coordinates:** The system of coordinates as described in paragraph 3.12(a) appears on all sheets of nonsectionalized drawings.

**3.17 Apparatus Index:** An Apparatus Index is usually not provided. If it is, no equipment location is shown, since the apparatus for small circuits is usually concentrated in a small area on a single equipment unit or central office frame.

**3.18 Arrangement of Information:** The arrangement of information on a nonsectionalized drawing is shown below in Table C.

TABLE C

#### ARRANGEMENT OF INFORMATION ON NONSECTIONALIZED DRAWINGS

SHEET	CONTENTS
1 (and 2 if required)	Sheet Index Supporting Information Apparatus Index Lead Index Option Index Transmission Test Requirements Table Working Limits Circuit Notes (100 Series) Equipment Notes (200 Series) Information Notes (300 Series) Cross-Connecting Information Notes (400 Series)
Subsequent Sheets	Functional Schematics (FS) Apparatus Figures (APP FIG) Sequence Charts (SC) Circuit Requirements Table (CRT) Timing Requirements Table (TRT) Cabling Diagrams (CAD) Block Diagrams (BD)

#### 3.19 Placement of Information on Sheets

(a) If space permits, the Apparatus Figure (APP FIG) may appear on the same sheet as the Functional Schematic (FS).

(b) Sequence Charts (SCs) are generally located on a separate sheet, but if there is sufficient space they may be located on the same sheet as the FS to which they apply. Circuits with only a few operating elements may not require an SC.

(c) If space permits, Cabling Diagrams (CADs) may appear on the same sheet as the Circuit Requirements Table (CRT).



**3.20 Addition of New Sheets:** A new sheet added during the reissue of a nonsectionalized drawing usually is placed at the end of the drawing. However, new sheets also may be inserted as described in paragraph 3.11.

#### 4. INDEXES AND SUPPORTING INFORMATION

##### A. Sheet Index

**4.01 Purpose:** The Sheet Index lists the contents and the latest issue of every sheet of a drawing.

##### 4.02 Format of Sheet Index for Sectionalized Drawings

(a) **SDs Initially Issued Before September 1, 1980:** Fig 1A shows a Sheet Index for a sectionalized drawing issued prior to September 1, 1980. The column designated CONTENTS lists the subject or title of the circuit information shown on each sheet. The column designated SHEET NO lists the sheet numbers in sequence according to the sections, eg, A1, A2, B1, C1, etc. The column with the overall designation of ISSUE NO shows the latest issue of each sheet and provides a record which indicates the sheets affected by a reissue of the SD.

(b) **SDs Initially Issued After September 1, 1980:** The format of the Sheet Index is the same as that described in paragraph 4.02(a) except that the index only shows the current issue or issues (if concurrent) of each sheet. It does not provide a historical record of which sheets were reissued for each reissue of the SD. See Fig 1B.

**4.03 Format of Sheet Index for Nonsectionalized Drawings:** Prior to September 1, 1980, nonsectionalized drawings of eight or more sheets used the format described in paragraph 4.02(a) except that the sheet numbers were listed as 1, 2, 3, etc. Drawings consisting of less than eight sheets used the format shown in Fig 1C.

##### B. Supporting Information

**4.04** The Supporting Information Table references the Equipment Design Requirements (J Specs), Equipment Drawings (J or ED), and other applicable information such as Circuit Pack Schematic (CPS & EPS) drawings, Circuit Pack Information SD- Drawing, Bell System Practices (BSPs), Trunk

Tables, etc. The Supporting Information Table always appears on the first sheet of an SD- drawing. See Fig 1D.

##### C. Apparatus Index

**4.05 Purpose:** The Apparatus Index contains information for locating all components (except contact protection networks, as explained in paragraph 4.07) on the FSs and in the APP FIGs. On some circuits the Apparatus Index also indicates the frame equipment location of the components. See Fig 2A through D.

**4.06 Types of Tables:** Two types of tables may appear in the Apparatus Index. The first table lists circuit packs in numerical order of equipment location [see (a)]. The second table lists all designated components (including circuit packs) [see (b)].

##### (a) Circuit Packs by Equipment Locations:

This table lists circuit packs in numerical order of their equipment locations and is divided into three columns, arranged as follows:

- (1) The EQPT LOC column lists the circuit pack equipment locations in numerical order.
- (2) The FS column lists the FS sheet number and location coordinates of the circuit pack.
- (3) The APP FIG column lists the APP FIG number in which the circuit pack is located.

(b) **Components by Designations:** This table lists all designated components under their respective categorical headings. The headings are listed on a noun-first basis. Circuit packs (PACK, CIRCUIT) are listed first, followed by relays, and then all other types of components in alphabetical order such as amplifiers, capacitors, keys, etc. This table is divided into four columns arranged as follows:

- (1) The DESIG column lists the component designations in numeric-alpha order under their respective categorical headings. When components have both functional and reference designations, only the functional designations are listed.
- (2) The FS column lists the FS sheet number and location coordinates of the components.

The location coordinates for relays refer to the location of the relay cores.

(3) The APP FIG column lists the APP FIG number of which the apparatus is a part.

(4) The EQPT column is always provided but is used only when it is necessary to show where the apparatus is located on the frame. Equipment locations may be one of the following two types:

a. Mounting plate locations are usually necessary only when the apparatus is spread over 8 or 10 mounting plates or over more than one equipment bay. The bay number is shown first, followed by the plate number, eg, 1-10. It also may be necessary to show the apparatus location when the apparatus is mounted in a cabinet or on a panel. In these cases, the cabinet or panel designation is shown.

b. Circuit pack locations are always provided when a coordinate system has been established for the equipment. The equipment location for circuit packs usually consists of the bay number, followed by the shelf level number and the circuit pack slot number on the shelf, eg, 01-034-29. In some cases the circuit pack locations may consist of only the shelf level number followed by the circuit pack slot number on the shelf, eg, 034-29.

**4.07** Contact protection networks usually are omitted from the Apparatus Index since they usually are connected to and given the same designation as the apparatus with which they are associated. However, they are included in the Apparatus Index when used for purposes other than contact protection or not directly associated with a particular piece of apparatus.

#### D. Lead Index

**4.08 Purpose:** The Lead Index lists the FS and CAD coordinate locations of all leads that connect to external circuits (see Fig 2C). A Lead Index is provided when there are two or more sheets of FS figures.

**4.09 Arrangement of the Lead Index:** Titles of connecting circuits are shown as the table heading above their associated group of leads and are

listed in alphabetical order on Issue 1. When there is insufficient space on subsequent issues, new circuit titles may be inserted disregarding alphabetical order if there is a Lead Index Connecting Circuits Table (see paragraph 4.10). The Lead Index is arranged in three columns as follows:

(a) The DESIG column lists the designations of the leads that connect to the external circuit. These designations are listed in numeric-alpha order within the table.

(b) The FS LOC column lists the FS sheet number and coordinate location of each lead. When a group of leads is shown bracketed on the FS figures, the coordinate location for the center of the bracket is listed for those leads.

(c) The CAD LOC column lists the CAD sheet number and coordinate location of each lead. When a group of leads is shown bracketed in the CADs, the coordinate location for the center of the bracket is listed for those leads. When CAD information is shown on a sheet that does not have location coordinates, the CAD number is listed, eg, CAD 2. This type of entry may occur on nonsequentialized drawings when CADs appear on the same sheet as the Circuit Requirements Table.

#### 4.10 Lead Index Connecting Circuits Table:

When a Lead Index requires more than one sheet on a new or redrawn SD, the external circuit titles may be listed in a Lead Index Connecting Circuits Table (see Fig 2B) which immediately precedes the Lead Index. The external circuit titles are listed alphabetically and the sheet and coordinate location of where they appear in the Lead Index is given. On subsequent issues of the SD, circuit titles may be added to the Lead Index disregarding alphabetical order, but they are always added alphabetically to the Lead Index Connecting Circuits Table. This allows the user to locate readily any external circuit title in the Lead Index.

#### E. Option Index

**4.11 Purpose:** The Option Index (see Fig 2D) lists options shown on an SD for wiring, apparatus, and APP FIGs.

**4.12 Arrangement of the Option Index:** The Option Index is arranged in four columns as follows:

- (a) The APP or WRG column lists optional APP FIGs first. Numbered APP FIGs are listed before lettered APP FIGs, if any. Single-lettered option designations of optional apparatus and wiring are listed next in reverse alphabetical order. Multilettered option designations follow next with the first letter in reverse alphabetical order and the second letter in alphabetical order, eg, ZA to ZZ, YA to YZ, ending with AA to AZ.
- (b) The RATED ON ISSUE column gives the rating history of each option.
- (c) The REF NOTES column lists note numbers that pertain to particular options. The Feature or Option note and the Record of Changes note are not referenced.
- (d) The LOCATION column lists the FS coordinate locations, APP FIG numbers and CAD numbers of options. When an option appears eight or more times on the same FS sheet, only the sheet number is entered in the LOCATION column, eg, SHEET B#3.

## F. Designation Mnemonic Index

**4.13** This index is usually provided on drawings that use mnemonics as designations. It lists in numeric-alpha order the mnemonic and the definition of all lead and component designations used on the SD. For lead designations, the FS number of the initial output is provided. For leads connecting to external circuits, the FS number of the first appearance of the lead designation is provided. Typical entries are shown in Fig 3.

## 5. FUNCTIONAL SCHEMATICS

**5.01 Description:** A general description of Functional Schematics (FSs) is given in paragraphs 2.03 and 2.04.

**5.02 Examples of FS Information:** Standard methods of presenting information on an FS, together with detailed explanations of the symbols used, are shown in Fig 4.

**5.03 Number of FSs on an SD:** The number of FSs in a circuit depends on the size and type of circuit. Circuits that perform several different

functions will have several FSs, whereas a small circuit, such as a trunk, might have only one FS.

**5.04 Titles of FSs:** Each FS is given a number and title. The title may indicate a circuit function, such as Pulse Counting, or the name of the circuit, such as Trunk Circuit.

**5.05 Symbols for Contacts:** Two basic symbols represent contacts. They are designed to allow a circuit path to be shown according to its function. Therefore, each contact of a piece of apparatus can serve a different function and does not have to appear with its coil, as in the attached-contact schematics (see paragraph 2.01). The following symbols represent contacts:

- (a) A line with a superimposed X (\*) represents a make contact (open when unoperated).
- (b) A line with a superimposed bar (+) represents a break contact (closed when unoperated).

**5.06 Battery Symbol:** Instead of using a battery symbol, the battery voltage is spelled out, eg, -48.

**5.07 Symbols in General:** The symbols used on FSs can, in general, be found in Section 005-108-111. Some symbols may be represented by a rectangle with the component type entered inside. Most rectangular symbols represent electronic components not easily represented by standard symbols due to their multiplicity of functions or components for which a specific symbol has not been established.

**5.08 Abbreviations and Condensed Patterns:** Abbreviations and condensed patterns may be used on FSs. However, an FS should always contain sufficient detail to permit a person familiar with the practices, but not necessarily familiar with the scope of the circuit, to interpret and apply the information.

**5.09 Repeated Information:** In general, an FS will show the circuit paths complete from battery to ground. Sometimes this may require repeating some information shown on other FSs or other circuits. As illustrated in Fig 4, Item 30, all external circuitry and circuitry repeated for clarity is enclosed within a double-line box.

**6. APPARATUS FIGURES****A. General**

**6.01 Description:** A general description of Apparatus Figures (APP FIGs) is given in paragraph 2.05.

**6.02 Contents of an APP FIG:** An APP FIG consists of a grouping of apparatus that can be conveniently manufactured or ordered as a unit. The contents of an APP FIG are determined by the equipment, manufacturing, and optional ordering considerations, and are not based on the contents of any particular FS. Therefore, one APP FIG may contain apparatus from several different FSs. When only one or two components in an APP FIG are required, a separate APP FIG containing just those components can be shown, or the components may be shown as a letter-designated option within another APP FIG.

**6.03 Optional APP FIGs:** Depending on circumstances, an APP FIG may be nonoptional (meaning that it is always furnished), optional as a whole, or optional in part.

**6.04 Examples of APP FIG Information:** Fig 5A through P gives examples of various types of components and the information normally provided. In an APP FIG, circuit packs are listed first, followed by relays and then the remaining components in alphabetical order noun first, eg, PACKS, CIRCUIT.

**6.05 Individual Component Information:** In general, all apparatus that comprises a circuit is listed in an APP FIG; exceptions are mounting plates, connecting blocks, terminal strips, lamp sockets, tube sockets, and components mounted on a circuit pack. Components that are part of an assembly appearing on the FS and not documented elsewhere (CPS, EPS, or APS drawing) are listed in the APP FIG on an E/W (equipped with) basis to the overall assembly. See Fig 5M, Component Assembly. The following information is shown as required for each component listed in an APP FIG:

- (a) Type of Component
- (b) Functional or Reference Designation
- (c) Option Designation

- (d) Code (Complete Ordering Information)
- (e) FS Location of Each Component or Component Part
- (f) Quantity (if more than one designation is associated with a single code)
- (g) Contact Numbering and Arrangement
- (h) Terminal or Pin Numbers.

**6.06 Tabular and Graphic Representation:**

Whenever practical, the information in an APP FIG is shown in basic tabular form (see Fig 5P). Tabular form includes simple components, such as resistors, listed in a top-down order, and more complex components, such as circuit packs or relays, listed in a table. A graphic and tabular representation is used when it is necessary to show a complete symbol for components whose parts have been shown detached or separated on the FSs or when a tabular arrangement by itself is insufficient.

**B. Circuit Packs**

**6.07** Basically three types of tables may be used to list circuit packs (CPs) in the APP FIG. A description of each table is as follows:

- (a) **Basic Table Format:** This table, illustrated in Fig 5A, is most frequently used for listing CPs and is arranged as follows:
  - (1) The EQPT LOC line shows the physical location of the CPs in the equipment. This location is expressed in the coordinate system described in paragraph 4.06(b), (4)b. The order of the entries made in the table approximates that of the CPs in the equipment.
  - (2) The DESIG line is used when a single functional designation is assigned to an entire CP. The DESIG line is generally omitted when designations are associated with element identification letters as in ESS projects (see Fig 5C).
  - (3) The CLEI code line shows the first seven characters of the Common Language Equipment Identification code for the CP.
  - (4) The CODE line shows the code of the CP.

- (5) The OPTION line shows the option (if any) for each CP.
- (6) The DESIG column shows functional designations assigned to individual CP elements or parts of CP circuitry shown on FSs within boundary line enclosures. When no designations are assigned to the circuit elements or CP parts, the DESIG column may be omitted.
- (7) The TERM column lists the highest numbered output terminal for each circuit element or CP part. When the entire CP circuitry is shown within a single boundary line enclosure on the FS, only the highest numbered output terminal for the CP is entered in the TERM column, if no spare terminals need to be listed. Terminal numbers are listed in descending order from top to bottom of the TERM column. The TERM column is eliminated when circuit elements or CP parts are identified on FSs with element identification letters (see Fig 5C).
- (8) The LOC column lists the FS location of the highest output terminal for each circuit element, CP part, or entire CP shown on the FS. The absence of an entry in the LOC column for a particular terminal identifies it as a spare.
- (b) **Table Used for Elementized CPs:** When element identifiers and symbol numbers are assigned to circuit elements, CP parts, or entire CPs on FSs (as in several ESS projects), the table format shown in Fig 5C may be used. This format differs from the basic format described in that the TERM column shown for each CP entry is eliminated. For ESS projects the LOC heading is listed as FS/SYM. In addition, ELEM ID columns are shown at the left and right ends of the table. Element identification letters are entered in the ELEM ID column in alphabetical order from top to bottom. Because it is not likely that all the identification letters listed in the ELEM ID column will apply to each CP, the word SPARE is entered in the DESIG column to identify spare elements or CP parts. The absence of either a DESIG and LOC (FS/SYM) entry or the word SPARE in the DESIG column indicates that the element identifier does not apply to that particular CP.
- (c) **Simplified Format:** A simplified format for depicting circuit packs in an APP FIG may be used when a complete circuit pack is shown in

one or at most a few FS locations, as shown in Fig 5B. Although the format is different from that of the Basic Table, the information that applies to the column headings, DESIG, EQPT LOC, CLEI CODE, CODE, FS LOC, and OPTION is the same. See (a) above.

### C. Relays

**6.08 General:** Several table formats represent the various types of relays in an APP FIG. The basic information in each table is the DESIG line, OPTION line, CONT ARR column, and LOC column. Since information for some relays varies, these differences are covered in paragraphs 6.13 through 6.18. A description of the basic table and associated information follows.

**6.09 Basic Table Information:** The tables are divided into major columns formed by heavy vertical lines which contain information for a particular relay. A column at each end of the table shows the type of information listed for each relay (see Fig 5D) and consists of the following:

- (a) The DESIG line shows the functional designation of each relay. Relays are usually listed in numeric-alpha order.
- (b) The CODE line shows the code of each relay.
- (c) The OPTION line shows the option (if any) assigned to each relay.
- (d) The numbers appearing in the column at the extreme left or right of the table refer to the spring or contact position numbers. The contact arrangement of a position on a particular relay is determined by reading across from the spring position number to the CONT ARR (contact arrangement) column. If no contact arrangement is given in the table, that relay is not equipped with a contact in that position. The location on the FS of the contacts provided in a particular position is determined by reading across to the LOC (location) column. If location information is not given for a contact, that contact is not used in the circuit.
- (e) The COIL line shows the FS location of each relay coil.

**6.10 Abbreviations of Contact Arrangements:** The following abbreviations are used in APP FIG tables for relay contact arrangements.

M	Make
MB	Make Break
M-B	Make-Break
MBM	Make Break Make
MM	Make Make
M-M	Make-Make
B	Break
BM	Break Make (Nonsequence transfer)
BMB	Break Make Break
BMM	Break Make Make
BM-M	Break Make-Make
EB	Early Break
EBM	Early Break Make (Sequence transfer)
EM	Early Make
EMB	Early Make Break (Continuity)
PB	Preliminary Break
PBEM	Preliminary Break — Early Make (Preliminary continuity with respect to late contacts)
PBM	Preliminary Break Make
PM	Preliminary Make
PMEB	Preliminary Make — Early Break (Preliminary transfer with respect to late contacts)

**6.11 Split Contacts:** When separate functions on different FSs are controlled by the make and break contacts of a transfer contact having direct battery or ground on its common spring, the transfer may be split into its make and break components on the FS. This avoids leads between FSs. The double location is given in a footnote referenced by letters a, b, etc, in the LOC column for each split transfer. This is illustrated in Fig 5D, relay MT, contact 12.

**6.12 Options:** If, because of options, a contact is shown at more than one location on the FS, the location is shown as described above for split contacts. This is illustrated in Fig 5D, relay MR, contact 6.

#### Wire-Spring Relays

**6.13 Wire-spring relays** having 12 or 24 contacts are shown in tables as illustrated in Fig 5D and described in paragraph 6.09.

(a) **Dual armature wire spring relays** such as the AK type are shown in tables as illustrated in Fig 5D. To determine which two halves are mounted together, the notation MTD/W( ) is shown above each relay column. Each half has a maximum of five contact positions. Contact springs 1

to 5 and the associated coil (terminals 1L and 2L) form the lower half of the relay. Contact springs 8 to 12 and the associated coil (terminals 1U and 2U) form the upper half of the relay. Because of this division of contact numbers, only five contacts are tabulated for each half of the relay. The CODE line shows the notation "1/2" preceding the code, eg, 1/2AK8.

(b) **Wire spring multicontact relays** are shown in tables as illustrated in Fig 5E and described in paragraph 6.09. Note that no column is included on this table for indicating the contact arrangements. This is because all contacts of the wire-spring multicontact relays are makes. The 287A and 288A relays in Fig 5E consist of two units (upper and lower), each having a coil and 30 springs. The methods for listing these double-unit relays in the APP FIG are, in general, the same as those described in paragraph 6.09.

#### Dry Reed Relays

**6.14 Dry reed relays** may be shown in several different ways as illustrated in Fig 5F, G, and H, depending on the coil and contact arrangement and the grouping of the relay parts within an FS.

(a) Fig 5F illustrates several relays whose parts are shown grouped together on an FS.

(1) The DESIG column lists the functional designation of each relay unit used in the circuit. For example, A0, 1, 2, 4, 7 indicates that coils 1, 2, 3, 4, and 5 are used. CT0, 1, 2 indicates that coils 1, 2, and 3 are used. DVA, CG10, CN, CR, TN indicates that coils 1, 2, 3, 4, and 5 are used. With each coil, a coil contact and load contact having the same designation are shown on the FS. The number in brackets, [1], indicates that one 293A relay is required.

(2) The LOC column shows the location on the FS of the items listed in the subcolumns. For example, the COIL column lists the location of the coils and the associated A (coil) contacts. The B CONT column lists the location of the B (load) contacts.

(b) Fig 5G illustrates a 293-type relay whose parts are shown separated throughout the FSs. The table is designed so an FS location can

be given to each of the five relays and their associated A and B contacts which make up the 293A relay.

(c) Fig 5H illustrates a 295-type relay. The table information is basically the same as appears in the basic table format described in paragraph 6.09 except that the CONT column is subdivided into six lines, lettered A, B, C, D, E, and F from bottom to top. These letters associate the contacts of the relay shown in the diagram with the information listed in the table. They are used for reference only and do not appear on the FS.

#### Mercury Contact Relays

**6.15** Mercury contact relays (see table for 275- and 276-type relays in Fig 5I) are shown individually or in tabular form. If there is more than one relay of a type, the tabular form is generally used. The table is similar to those described previously except that the numbers in the left-hand column refer to the terminal numbers of the relays. Because of the different internal contact arrangements of these relays, the arrangement is illustrated to the left of the table.

#### Flat-Spring Relays

**6.16** Flat-spring relays are listed in a table (see Fig 5J) that contains the basic information described in paragraph 6.09. As noted in Fig 5J, each relay contains a top and bottom portion consisting of a maximum of 12 contacts grouped together. The contact arrangement of a particular relay is determined by reading across from the spring position numbers to the CONT ARR column.

#### General Relay Tabular Form

**6.17** If an APP FIG contains relays having the same code, they are listed as shown for the S63 relay in Fig 5K except as noted above for relays of the wire-spring, dry reed, mercury contact, and flat-spring types. The information is arranged as follows:

- (a) The designations to the right of the relay code are the relay functional designations. All information shown under each designation applies to the same relay.
- (b) Any option designations applying to the relays are shown directly above the relay designations.

(c) The FS location of the coil or a contact of a particular relay is determined by reading across from the symbol in the illustration to the relay designation column.

#### Individual Relays

**6.18** Individual relays are listed as shown for the GT, CLR, RL, TR, and PT relays in Fig 5L. The information is arranged as follows:

- (a) Relays are grouped together, and the group is headed by the word RELAY.
- (b) The symbol for each relay is shown.
- (c) The code is shown above each symbol.
- (d) The relay functional designation is shown above the code.
- (e) Option designations, if any, are shown to the left of the functional designation.
- (f) The FS location is shown adjacent to each detached contact of the relay.

The PT relay illustrated in Fig 5L is a 266A-type. The 266-type relay consists of two R-type relays permanently joined. The left- and right-hand units are referred to as PTL and PTR respectively, and are indicated as such on the FS. This relay has a set of make contacts actuated by the cover cap. At these contact locations on the FS, a notation is made that they are operated by the cap.

#### D. Capacitors

**6.19** Capacitors are listed in the APP FIG in the basic tabular form, as shown in Fig 5M and explained in paragraphs 6.05 and 6.06. The listing does not include capacitors that are part of units coded as network.

#### E. Component Assemblies

**6.20** Component assemblies are listed in the APP FIG in both symbolic and tabular form (see Fig 5M). All the components shown within the component assembly are listed to the right of the diagram under their categorical headings. The designations of these components match those used within the diagram. The LOC column lists the FS location of each component. The CODE column lists the code of each

component. The DESIG and CODE columns above the diagram refer to the mounting facility itself (in this example, a terminal strip). If several identical component assemblies are used in the circuit, a table similar to a circuit pack table may be used.

#### F. Connectors

**6.21** Connectors are listed in the APP FIG in tabular form, as shown in Fig 5M and explained in paragraphs 6.05 and 6.06.

#### G. Cords

**6.22** Cords are considered connecting devices and are listed under CONNECTOR in the APP FIG as shown in Fig 5M. When a component is coded as a cord, the word CORD is listed adjacent to the code in the code column. The heading CORD is listed in the APP FIG, but the only information it contains is the notation SEE CONNECTOR.

#### H. Diodes, Fuses, and Inductors

**6.23** These components are listed in the APP FIG in the basic tabular form, as shown in Fig 5M and explained in paragraphs 6.05 and 6.06.

#### I. Jacks

**6.24** Jacks are considered connecting devices and are listed under CONNECTOR in the APP FIG as shown in Fig 5M. When a connecting device is coded as a jack, the word JACK is listed adjacent to the code in the code column. The heading JACK is listed in the APP FIG, but the only information it contains is the notation SEE CONNECTOR. When the parts of a jack are shown at several FS locations, the complete jack symbol is shown in the APP FIG. The contacts are numbered with the jack viewed from the wiring side to permit identification of the detached contacts of the jacks on the FSs. The functional designation, the FS location of the contacts, the option (if any), and the code (see AL and BM jacks) are also provided as shown. When all parts of a jack appear at one FS location, the jack is listed in tabular form as shown for jacks A, B, etc.

#### J. Keys and Keytops

**6.25** *Types of Keys:* As shown in Fig 5N, an individual diagram is provided for each different functionally designated key. The functional designa-

tions appear above the diagrams for pushbutton- and adjacent to the diagram for turnbutton-type keys. This is illustrated by the LINE PERF key and the READJ-TST key, respectively. For lever-type keys, the functional designations are located as illustrated by the NORTH-SOUTH and EAST-WEST keys. The code of the key appears under the heading KEY. Any option designations appear to the left of the functional designation.

**6.26** *Numbering of Keys:* The springs of each key are numbered to identify the detached contacts of the key on the FS. Keys are numbered according to their type, as follows:

(a) *Lever-Type Keys:* Lever-type keys are divided into quadrants identified by the letters A, B, C, and D. The lettering of the quadrants is fixed in relation to the front of the key. The front of the key is defined as the end where the key code is stamped. The operation of the key lever toward the front of the key always operates the springs in the A and D quadrants. The quadrants are arranged in the diagrams so that the springs of the key are pictured in the same position as they appear to a person working on the wiring side of the equipment. If the key is mounted so that it is rotated either 90 or 180 degrees, the quadrants rotate accordingly. In each quadrant, the springs are numbered from the plunger out. A single- or double-ended arrow represents the plunger. The NORTH-SOUTH key diagram shows that the front of the key is toward the bottom of the frame as seen from the wiring side. In the EAST-WEST key diagram, the view shown is for a 479DW key mounted in a keyshelf as seen when the keyshelf is raised to permit access to the wiring side of the key. In this case, the front of the key is toward the front of the keyshelf.

(b) *Pushbutton- and Turnbutton-Type Keys:* The springs of pushbutton- and turnbutton-type keys mounted with their contact terminals in a vertical or horizontal array as viewed from the wiring side are numbered from bottom to top or left to right, respectively. When this type of key is mounted with its array of terminals in other than a vertical or horizontal position, the terminals are numbered as follows:

(1) When the key is mounted so the terminal array is positioned 45 degrees or less from the horizontal, the key is considered to be rotated the shortest distance necessary to bring the



array into horizontal alignment, and the terminals are numbered from left to right.

- (2) When the key is mounted so the terminal array is positioned more than 45 degrees (but less than 90) from the horizontal, the key is considered to be rotated the shortest distance necessary to bring the array into vertical alignment, and the terminals are numbered from bottom to top.

**6.27 Keytops:** A keytop diagram is given for each different functionally designated key and indicates the position in which a key is mounted in the equipment. Keytop diagrams, however, are not shown for individually mounted pushbutton keys which have only one operating position. For lever-type keys, non-normal orientation resulting in the code being positioned at the top or left in a vertical panel or toward the hinge in a closed keyshelf is indicated with the word "FRONT" appropriately located in the keytop diagram. The word "FRONT" is not shown when a key is normally mounted with its code at the bottom or right in a vertical panel or toward the front of a closed keyshelf. Keytop diagrams shown in Fig 5N illustrate normal and non-normal orientation of lever-type keys.

#### K. Lamps and Networks

**6.28** Lamps and networks are listed in the basic tabular form, as shown in Fig 5N and explained in paragraphs 6.05 and 6.06. Built-up-type contact protection, which consists of a coded capacitor and a coded resistor, is not listed under networks unless they are coded collectively as network. The individual parts, when not coded as network, are listed under capacitors and resistors. Contact protection networks are listed only when used for purposes other than contact protection. Lamp colors other than white are specified in the CODE column.

#### L. Outlets and Receptacles

**6.29** Outlets and receptacles are listed in the basic tabular form, as shown in Fig 5N and explained in paragraphs 6.05 and 6.06.

#### M. Plugs

**6.30** Plugs are considered connecting devices and are listed under CONNECTOR in the APP FIG as shown in Fig 5M. A component coded as a

plug is listed in a tabular arrangement under the heading CONNECTOR and the word PLUG is shown following the code in the CODE column. The heading PLUG is also listed but the only information it contains is the notation SEE CONNECTOR. See Fig 5P.

#### N. Potentiometers, Rectifiers, and Regulators

**6.31** These components are listed in the APP FIG in tabular form, as shown in Fig 5P and explained in paragraphs 6.05 and 6.06.

#### O. Resistors

**6.32** Resistors are listed in tabular form as shown in Fig 5P. Quantity indications, when required, are shown to the left of the functional designation. Note that the ordering information under the heading CODE is complete but varies depending upon the type of resistor. For example:

- (a) For resistors A and B, the codes 18AG and 19GH are sufficient since these particular codes define the resistance value and the tolerance.
- (b) For resistor C, the code 145B defines the type and the tolerance, but not the resistance value. Therefore, the resistance value is shown.
- (c) For resistor D, the required tolerance is specified by L1, L2, or L3 (corresponding to  $\pm 5$  percent,  $\pm 10$  percent, or  $\pm 20$  percent). Also, the required resistance value is shown.

#### P. Selectors

**6.33** Selectors are shown in tabular form as in Fig 5P. The functional designation, option (if any), selector code, and bank code are listed. The ARC column is divided into a number of columns, one for each arc of the bank. When the terminals of each arc appear at one FS location, one location coordinate is shown in the column. When the terminals of any arc appear at many FS locations, the arc columns are subdivided into two columns, one designated TERM, which lists the terminals of the arc, and the other designated LOC, which lists the FS location of the terminals. The next major column is designated STEP MAG LOC and shows the FS location of the stepping magnet core. The last column, designated INT CONT LOC, lists the location of the interrupter

contacts. When the interrupter contacts are composed of several springs, a spring combination symbol is shown in this column along with the locations of the individual springs.

#### Q. Switches

**6.34** Fig 5P shows the APP FIG arrangements for these various types of switches:

- (a) Single-pole toggle switches (CLP, PLP, etc) are listed in tabular form showing the functional designation, the location, the code, and the option (if any).
- (b) A double-pole, double-throw toggle switch is listed as illustrated by the MB switch.
- (c) Section-type switches are listed in several ways depending upon the switch and its use on the FS.

(1) Switches with only one circuit per section that have contacts shown at one FS location are listed as illustrated by the AUD TEST switch. When the contacts appear at many FS locations, the switch is listed in a table as illustrated by the FREQ SWITCH. This table shows the functional designation, code, option (if any), and the FS locations of the terminals of the various parts of the sections.

(2) Switches with more than one circuit per section are listed in a table illustrated by the PULSE TEST switch. This table shows the functional designation, option (if any), code, and the FS locations of the terminals of the circuits of the various sections.

(d) Crossbar switches are listed in tables arranged in various ways, depending on how the switch is used in the circuit. The illustrations in Fig 5P cover several different usages. These tables and illustrations, with some minor variations, cover most conditions.

#### R. Switchtops

**6.35** Switchtop figures are provided for all switches except toggle and pushbutton types. The switchtop figures are adjacent to tabular or graphic representations of the switch (see Fig 5P). The

switchtop figures indicate the actual orientation of the switches in the equipment and are the basis for markings on the equipment.

#### S. Thermistors, Transformers, Transistors, Tubes, and Varistors

**6.36** These components are listed in the APP FIG in tabular form, as shown in Fig 5P and explained in paragraphs 6.05 and 6.06.

#### T. Other Components

**6.37** Other components not specifically covered in paragraphs 6.07 through 6.36 are entered in the APP FIGs in a tabular and graphic format consistent with the preceding paragraphs.

### 7. NOTES AND GENERAL CIRCUIT INFORMATION

#### A. Circuit Notes

**7.01 Definition:** Circuit Notes describe how to order, engineer, and install a circuit. They are assigned the 100 series of numbers.

**7.02 Contents:** Due to the partitioning of E&M Only and O&M information on an SD (see paragraph 2.10), the information each note category contains is not the same on every SD. The type of Circuit Note information on each SD depends on one of the following two conditions:

(a) *SDs Prepared or Initially Issued Before September 1, 1980:* For SDs that have been prepared or have an Issue 1 date prior to September 1, 1980, the Circuit Notes are arranged as follows:

- (1) Note 101 — Fusing Note
- (2) Note 102 — Feature or Option Table
- (3) Note 103 — Record of Changes Table
- (4) Note 104 — Network Values Table
- (5) Notes 105-199 — Miscellaneous Circuit Notes

(b) *SDs Prepared or Initially Issued After September 1, 1980:* For SDs that have been prepared or have an Issue 1 date after September 1, 1980, the Circuit Notes are arranged as follows:

- (1) Note 101 — Fusing Note
- (2) Note 102 — Network Values Table
- (3) Notes 103-199 — Miscellaneous Circuit Notes

**7.03 Fusing Note:** This note is shown in tabular form (see Fig 6). It provides information for the battery, ground, and tone supply leads, and is arranged as follows:

- (a) The DESIG column lists the designations of the battery, ground, and tone supply leads that are externally protected. The designations of these tone supply leads agree with the designations of the associated fuses.
- (b) The FUSE AMP column lists the rated capacity of the devices in amperes.
- (c) The POTENTIAL column lists the nominal potential of the batteries, the abbreviation GRD for the ground leads, and the name of the tone supply leads, such as DIAL TONE.
- (d) The ONE PER column indicates that one fuse is needed for each part of the circuit listed in the column.
- (e) Battery symbols, voltage ranges, and explanatory notes are shown at the bottom of the table.
- (f) On circuits for which connecting block terminals are shown on the FS and in which the power is supplied through connecting block terminals, an added column designated TERM DESIG shows the block and terminal to which the supply leads are connected. If the terminal differs for different options, the option designation is shown (in a circle) to the left of the block designation.

Explanatory notes and the voltage limits of the circuit are shown at the bottom of the table.

**7.04 Feature or Option Table:** Prior to September 1, 1980, the FEATURE AND OPTION table was CIRCUIT NOTE 102. All drawings prepared or issued after that date will have this note as INFORMATION NOTE 302. See paragraph 7.10 for details concerning this table.

**7.05 Record of Changes Table:** Prior to September 1, 1980, the RECORD OF CHANGES table was CIRCUIT NOTE 103. All drawings prepared after September 1, 1980, will have this note as INFORMATION NOTE 303. See paragraph 7.11 for details concerning this table.

**7.06 Network Values Table:** This table shows the resistance and capacity of the networks in the circuit (see Fig 9). If no networks are used in a circuit, the note is reserved for network information that may be required on later issues of the drawing. The term network refers to a coded apparatus unit containing a resistor and a capacitor. The term applies whether the unit is used for contact protection, termination of a transmission line, or any other purpose. The table is arranged as follows:

- (a) The NETWORK NO column lists the arbitrarily assigned numbers shown as part of network symbols throughout the FSs. These numbers are for value reference only and do not indicate the functional designation of the networks.
- (b) The RESISTANCE IN OHMS column lists the nominal value, in ohms, of the resistance part of the network.
- (c) The CAPACITANCE IN  $\mu\text{F}$  column lists the nominal value, in microfarads, of the capacitance part of the network.

#### B. Equipment Notes

**7.07** The 200 Series notes are reserved for equipment information and are referred to as Equipment Notes. These notes are primarily intended for use in the preparation of documentation called manufacturing information. They may also be used by the installer. They cover mounting restrictions of apparatus, size of wires, length of leads, balancing of capacitors, resistance of leads, running of leads, etc.

#### C. Information Notes

**7.08** The 300 Series notes, referred to as Information Notes, provide information for operating and maintaining equipment or apparatus covered by the drawing. Information Notes also provide information of a general nature which cannot be correctly listed with the other categories of notes. They cover interrupted intervals of timing, normal post springs, position of switches, direction of transmission, block diagrams, theory schematics, etc.

## SECTION 005-109-101

(a) Information Notes are arranged as follows:

- (1) Note 301 — Unit of Values Note
- (2) Note 302 — Feature or Option Table
- (3) Note 303 — Record of Changes Table
- (4) Notes 304-399 — Miscellaneous Information Notes

**7.09 Unit of Values Note 301:** This note indicates the units of value for capacitance, resistance, inductance, and voltage, as applicable, used throughout the drawing, with the exception of the J and K sections. This note is repeated in the J and K sections.

**7.10 Feature or Option Table:** This table shows the apparatus and wiring necessary for particular features and options (see Fig 7). This table is arranged as follows:

- (a) The FEATURE OR OPTION column lists the features or options that can be ordered separately.
- (b) The APP FIG column shows the APP FIG numbers that must be provided to obtain the associated features.
- (c) The APP OR WRG column lists the letter-designated component or wiring options that must be provided to obtain the associated feature.
- (d) The QUANTITY column lists the quantity of each APP FIG required to obtain the associated feature. Quantities are specified per a unit of circuitry or hardware ranging in size from an APP FIG to an office. Quantities are not generally listed for lettered options since they are usually provided automatically as part of the APP FIG.

**7.11 Record of Changes Table:** This table lists changes made to the circuit during the life of the drawing by indicating the addition of or changes in the rating of the APP FIGs and options in the circuit. In some instances, codes of components rather than option letters are shown in the table (see Fig 8). The information is arranged as follows:

(a) The CHANGED ON ISS column lists the drawing issue number and change classification for those changes for which a record is being kept.

(b) The IF JOB RECORDS DO NOT SPECIFY column lists particular options, APP FIGs, or types of components.

(c) The THIS OPTION WAS FURN column lists particular options or APP FIGs, or may list the word NONE. This column of information is related to the column designated IF JOB RECORDS DO NOT SPECIFY.

(d) The SEE NOTE column refers to Circuit Notes.

(e) The STD column lists options, APP FIGs, or codes of apparatus whose use in the circuit is rated Standard.

(f) The A&M column lists options, APP FIGs, or codes of apparatus whose use in the circuit is rated Additions and Maintenance Only.

(g) The MD column lists options, APP FIGs, or codes of apparatus whose use in the circuit is rated Manufacture Discontinued.

(h) The MDNO column may appear as part of this table. It indicates the rating Manufacture Discontinued Not Orderable for apparatus-coded products whose circuitry is controlled by that drawing.

### D. Cross-Connection Information

**7.12 Information required for assigning and making cross-connections that are subject to periodic changes is sometimes listed on the SD, usually in a cross-connection Information Note. Any explanatory note may be assigned to the 400 Series. This information is required by the field to determine the following:**

(a) The conditions that require specific terminals to be cross-connected.

(b) How to locate the punchings on the equipment (that is, the designations of the terminal strips and punchings).

- (c) The type and color of wire used to cross-connect specific punchings.

Two methods of presenting cross-connection information in the circuit drawing are described below:

- (d) All information is placed in tables with references, if required, to notes in the 400 Series. These notes are a combination of explanations and schematics.
- (e) The information is placed in a series of FSs numbered in the next available 100 group to the regular FSs. Each FS shows the cross-connection between specific punchings (or groups of punchings) and in some cases, shows the complete circuit to the punchings. References are made on the FSs to the 400 Series notes which explain the conditions under which the cross-connections are made.

#### E. Transmission Test Requirements Table

7.13 When required, the allowable transmission losses for an entire transmission circuit and for individual pieces of apparatus affecting transmission in the circuit are listed in tabular form. Fig 10 shows a Transmission Test Requirements Table. These tables are described in detail in Section 005-121-101.

#### F. Working Limits Table

7.14 The working limits table shown on SDs may include the following types of information:

- (a) Maximum external circuit loop
- (b) Minimum external circuit loop
- (c) Maximum conductor loop
- (d) Minimum insulation resistance
- (e) Earth potentials
- (f) Sleeve resistance
- (g) Voltage limits for different maximum external circuit loops.

Fig 11 shows a typical Working Limits Table.

#### 8. SEQUENCE CHARTS

8.01 *Description:* A general description of Sequence Charts (SCs) is given in paragraph 2.06.

8.02 *Number of SCs in a Circuit:* As many SCs as necessary are used to explain the operation of the circuit. Each circuit function may be covered by a separate SC. A function of the circuit may be the operation of normal calls, the operation of abandoned calls, the operation of the timing part of the circuit, etc.

8.03 *External SC Information:* Although SCs are presented on a circuit basis, related operations of connecting circuits are included when necessary to preserve continuity of operation of a call. Thus, a connected story is given even though the functions involve a number of other circuits. The responsibility for continuity of description lies with the major circuit of a system.

8.04 *Titles of SCs:* Each SC is given a number and a title. The title shows the usage or function that the SC represents, such as Establishing Connection, Operator Answers At Distant End, Timing, etc.

8.05 *Examples of SC Information:* Interpreting an SC for an electromechanical circuit requires an understanding of the methods governing their arrangement and the symbols used. Fig 12 provides this information. Special symbols are not required for SCs associated with electronic circuitry, and the form and format of these SCs make them readily understandable.

8.06 *SC Index:* On very large sectionalized circuits, an SC Index may be provided. This index is the first item on the SC sheets and gives the SC locations of the operate and release symbols of each relay, electron tube, etc (see Fig 13). It is arranged by circuits rather than by SCs. The index in a particular SD lists the information for that SD first, followed by information for connecting circuits. The title of each circuit is shown above its associated group of information. The index is divided into three columns of information, arranged as follows:

- (a) The DESIG column lists the functional designations of the apparatus. Number designations are listed first in numerical order followed by letter designations in alphabetical order. Electron tubes are listed with the relays, and the word

TUBE is placed under the designation. If an option designation is required to identify a particular relay, the option designation is shown (circled) to the right of the functional designation.

(b) The OPR column lists the SC sheet and location coordinates of the operate symbols of the apparatus. If a designation appears at more than one SC location, information is listed for each appearance. If a designation occurs repeatedly in an SC, the number of the SC may be listed instead.

(c) The RLS column lists the SC sheet and location coordinates of the release symbols of the apparatus. If a designation appears at more than one SC location, information is listed for each appearance. If a designation occurs repeatedly in an SC, the number of the SC may be listed instead.

## 9. CIRCUIT REQUIREMENTS TABLES

**9.01** A Circuit Requirements Table (CRT) gives the electrical and/or mechanical requirements for relays and other apparatus, as required. Designations of apparatus are listed in numeric-alpha order under their respective categorical headings. The categorical headings are listed in alphabetical order, eg, Magnets, Relays, Tubes, etc (see Fig 14). This table lists the procedures (in the form of block and insulate directions and notes) when testing or readjusting the apparatus. This procedure lists all information necessary for taking equipment out of service but assumes the equipment has been made busy. When components mounted on circuit packs need to be listed in this table, the table is shown as part of the Circuit Pack Schematic (CPS) information, either on the J sheets of the SD or on a separate CPS drawing. The block and insulate procedures are required to do the following:

- (a) Prevent interference with the reading on the test set, locally or over paths from or through connecting circuits.
- (b) Prevent interference with connecting circuits.
- (c) Prevent the operation of alarms, traffic and plant registers, and lamps and signals on other frames or before operators. If registers cannot be protected by blocking or insulating, a CRT note specifies that local instructions apply to recording the registrations.

(d) Prevent the blowing of fuses and the removal of make-busy conditions.

(e) Prevent contact with hazardous voltages.

CRTs are described in detail in Section 005-120-101.

## 10. TIMING REQUIREMENTS TABLES

**10.01** A Timing Requirements Table (TRT) gives the timing requirements applied to relays, tubes, and relay interrupter circuits. See Fig 15 for an example. When timing requirements must be specified for only a few components, the information may be shown in the Circuit Requirements Table (CRT) or in an auxiliary Timing Requirements Table which follows Test Notes on the last page of the CRT. When timing requirements are shown for step-by-step relays in the CRT, the REMARKS column heading is changed to TIME REQ. The TRTs are described in detail in Section 005-120-101.

## 11. CABLING DIAGRAMS

**11.01** *Definition:* Cabling Diagrams (CADs) are interconnection diagrams that represent internal and external connecting information scattered over the FSs of the drawing. CADs provide the direct connection, connector, or terminal strip information necessary to connect to other SD circuits or for intraunit wiring requiring connectors or terminal strips. See Fig 16 for typical examples of CADs.

**11.02** *Assignment and Identification of Connecting Devices:* Connecting devices are assigned on a unit basis, a cabinet or chassis basis, or a bay or frame basis. Unit and cabinet devices generally serve only the SD of which they are a part. Bay or frame connecting devices may serve more than one SD. Identification of connecting devices is shown at the bottom of the terminal diagram. Codes of the connecting devices are not shown.

**11.03** *Use of CADs:* Cabling Diagrams are used for the following purposes:

- (a) To show intermediate points of connections, such as terminal strips, between two connecting SDs.
- (b) To show connections run directly from the electrical components of one SD to the electrical components of another SD.

- (c) To show cross-connections and straps.
- (d) To show internal connections between terminal strips, eg, when the SD uses more than one equipment frame or panel.

**11.04 Arrangement of CAD Information:** Cabling Diagrams are numbered in sequence beginning with CAD 1 and are positioned left to right. Detailed requirements pertaining to CADs are contained in Section 800-610-153. As shown in Fig 16, CADs are arranged as follows:

- (a) The associated APP FIG number(s) is shown directly under the CAD number.
- (b) The type of cabling and wiring is indicated. The conventions and symbols are explained in Section 005-150-101.
- (c) Titles of connecting circuits or apparatus are shown at the ends of connecting leads.
- (d) Information about internal lead connections is given in sufficient detail so the leads can be traced on the FS.
- (e) Terminal strips are designated and the terminals numbered. Terminals may be shown out of order when it improves the layout of the diagram or when a special grouping is desired. See Section 800-613-155 for specific requirements for the numbering and lettering of terminal strips.
- (f) In some switching systems, connectors are used as terminal strips. The connectors consist of male and female halves in a plug-in arrangement. They facilitate quick connection of a multitude of leads. In general, connectors are shown in the same manner as terminal strips.
- (g) Optional wiring and optional APP FIGs are indicated.
- (h) The method of interconnecting CADs is indicated, eg, LOCAL CABLE or SWITCHBOARD CABLE.

**11.05 CAD References:** The following sources provide more detailed information about CADs:

- (a) Section 800-610-153 — Cabling Diagrams for Schematic Circuit Drawings. This BSP contains detailed information on the content and format of CADs.
- (b) Section 800-613-155 — Specific Requirements for Numbering and Lettering Terminal Strips
- (c) Section 800-613-158 — Specific Requirements for Numbering and Lettering Distributing and Protector Frames
- (d) Section 005-150-101 — Wiring symbols, abbreviations, and definitions. Graphic and letter symbols used in CADs are defined here.

## 12. BLOCK DIAGRAMS

**12.01 Purpose:** Block Diagrams (BDs) represent, with blocks and a minimum of connecting lines, the significant functional relationship between FSs or groups of FSs on an SD, SDs of a system, and SDs of connecting systems.

**12.02 Types:** The three principal types of BDs and a brief description of their contents and relation to each other are as follows:

- (a) **FS BDs:** These BDs show the functional relationship between the FSs of an SD. Thus, an SD may have one or more FS BDs depending on the number of FSs in the entire SD. The number of leads that a signal path line represents is shown in parentheses at the originating ends of connecting lines. On long lines and for interrupted lines, the number of leads is shown at both ends of the lines. See Fig 17B for an example of an FS BD.
- (b) **Circuit BDs:** These BDs show the functional relationship between groups of FS BDs and possibly other related circuits. They are used only when an SD contains more than one FS BD as explained above. In general, single connecting lines between blocks are sufficient for conveying block interrelations. To aid in this, lines are labeled with word descriptions of the essential functions. See Fig 17A for an example of a Circuit BD.
- (c) **System BDs:** These BDs show the interrelationship of SDs that make up a system. They are prepared only when three or more SDs connect to make up a system. These BDs are shown on separate SDs and the words SYSTEM BLOCK DIAGRAM are included in the drawing title box.

Lead designations and signal flow arrowheads are shown only if they will clarify the circuit. See Fig 17C for an example of a System BD.

**12.03 System Application Diagram:** A System Application Diagram shows how the SDs of one system connect to SDs of related systems. This diagram is prepared when it will help explain how a particular system fits into a larger system. See Fig 17D for an example.

**12.04 BDs As Information Notes:** In addition to the BDs mentioned above, abbreviated BDs or simplified schematics may be shown in the D# section of an SD as part of the 300 Series Information Notes. However, any of the BDs mentioned in paragraph 12.02 may not be shown as Information Notes.

### 13. CIRCUIT PACK SCHEMATICS ON AN SD

**13.01 Use of J Section:** The preferred method of documenting a Circuit Pack (CP) is on a Circuit Pack Schematic (CPS) drawing for apparatus coded circuit packs and on an Equipment Product Schematic (EPS) drawing for equipment coded circuit packs; however, when a small project has only a few circuit packs unique to that particular project, the J section of an SD may be used. See Fig 18 for an example. A general description of a circuit pack is given in paragraph 2.08.

**13.02 J Section Contents:** A J section should consist of the items listed below. Each item is explained in detail beginning with paragraph 13.04. The arrangement of a J section depends on the amount of information to be documented and number of sheets required.

- (a) Circuit Diagram
- (b) Symbol
- (c) Component List
- (d) Manufacturing Reference Table
- (e) Input/Output Information
- (f) Circuit Description
- (g) Notes

- (h) Record of Changes Table
- (i) Manufacturing Test Requirements.

**13.03 Numbering of Sheets:** The J section letter and sheet number are shown on each sheet as a suffix to the drawing number. For example, on SD-27827-01-J1, the J1 represents section J, sheet 1. When more than one sheet is required to document a CPS code, all the sheets for that particular code are assigned the same sheet number but have different lettered suffixes beginning with the letter A. For example, if a CPS code required three sheets, the sheets would be numbered J1A, J1B, and J1C.

**13.04 Circuit Diagram:** The circuitry of a circuit pack is represented in the Circuit Diagram. Some basic requirements for its arrangement and representation are as follows:

- (a) **Reading Direction:** Diagrams are drawn so that signal flow is from left to right or top to bottom. When signal flow does not conform to either of these two methods, the direction of flow is indicated by directional arrowheads on the leads. Bidirectional signal leads are also indicated by arrowheads.
- (b) **Diagram Enclosure:** To clearly depict and locate CP terminations, the entire CP diagram is enclosed within boundary lines as shown in Fig 18. When a CP requires more than one sheet, the boundary lines are continued from sheet to sheet by leaving the boundary lines of the middle sheets open on both sides of the diagram. Heavy vertical lines are used to indicate CP pin terminations at the open sides. The boundary lines on the first and last sheets are open-ended only on one side, as applicable.
- (c) **Designations of Components:** Reference designations are assigned to all components and are based on the class of hardware to which each component belongs.

**13.05 Symbol:** A CP symbol represents the CP on an FS and is an abbreviated diagram of the CPS circuitry shown in the J section of an SD drawing. The duplication of the symbol in both the B# and the J sections is avoided when the symbol is shown in its entirety at one location in the B# section. In this case, the words AS SHOWN IN FS appear under the caption SYMBOL in the



**J section.** When a CP symbol is not shown in its entirety at one location in the B# section, it is shown in the J section under the caption SYMBOL (see Fig 18). An abbreviated symbol is a combination of analog symbols, logic symbols, or higher level rectangular symbols. The relationship of the CPS diagram and the symbol is accomplished by bracketing areas of circuitry in the CPS figure and indicating the function above the bracket. These functions are then represented by symbols in the SYMBOL diagram.

**13.06 Component List:** A Component List provides the designations, location (in some cases), and codes of all components mounted on the circuit pack. Each CPS has a component list. Component classifications are listed on a noun-first basis beginning with integrated circuits (Circuit, Integrated), followed by relays and then other components in alphabetical order. Components under each classification are listed in numeric-alpha order of their reference designations. Tables used for relays are the same type used in the APP FIGS (C# section) of an SD.

**13.07 Manufacturing Reference Table:** The entries in this table consist of the CP code and the connector requirements of the printed wiring board and frame. When CP documentation is borrowed from one project and is used in another, the Manufacturing Reference Table of the "borrowing" project will show the words CONTROLLING DRAWING followed by an SD number.

**13.08 Input/Output Information:** Information concerning the status of CP inputs and outputs during operating conditions is listed under the heading INPUT/OUTPUT INFORMATION. This information may consist of the following items:

- (a) Function of inputs or outputs and applicable conditions
- (b) Definition of lead designations
- (c) Signal level — logic states (1 and 0) and applicable voltage levels
- (d) Signal shape if other than common square waves
- (e) Requirements for synchronization among inputs and outputs

- (f) Propagation delay of signals from inputs to outputs
- (g) Conditions of polarity shift
- (h) Operating requirements for relays.

When it is more convenient to include input/output information in the Circuit Description (see paragraph 13.09), a reference is entered under the heading INPUT/OUTPUT INFORMATION that reads SEE CD-XXXXX-01.

**13.09 Circuit Description:** A Circuit Description (CD) provided in the J section sheets for each CP explains the internal operation of the circuit pack. These other types of information may be included in the CD of the circuit pack:

- (a) Reference to logic and truth tables on the drawing
- (b) Reference to sequence charts, timing charts, and waveforms shown on the drawing
- (c) Information concerning the sequence in which voltages are to be applied or removed, or other such precautionary information
- (d) Component adjustments that may be necessary
- (e) Reference information on the use of the circuit pack with other circuit packs
- (f) Any additional information that clarifies the CP circuit operation.

**13.10 Notes:** Information, usually common to a CP as a whole, that is not listed in any of the previously described sections of a J sheet, is listed under the heading NOTES. Some information that may be included under NOTES is:

- (a) Units of capacitance and resistance that generally apply throughout the documented circuitry.
- (b) Common battery and ground terminal table for integrated circuit devices. The codes are listed in numeric-alpha order.
- (c) Integrated circuit information.

## SECTION 005-109-101

- (d) Requirements for grounding spare integrated circuit device inputs.
- (e) Component code and value table for CPSs that document the circuitry of more than one coded CP.
- (f) Switchtop information.

**13.11 Record of Changes Table:** Circuit pack modifications identified by option letters are recorded in this table. The method of recording information in this table is similar to that for the Record of Changes Table in the D# section of a drawing (see paragraph 7.11).

- (a) **CD Record:** Circuit modifications may be described in the Circuit Description (CD) of the SD (see paragraph 16.01); however, this method is not preferred.
- (b) **Controlling and Noncontrolling CPS:** When the controlling CPS is borrowed and shown on another drawing, the Record of Changes Table is shown only on the controlling drawing. However, any circuitry modifications are shown on both drawings.

**13.12 Manufacturing Testing Requirements:** Manufacturing testing requirements for a CP may be documented in one of the following ways:

- (a) An X Specification or other type of specification may be used for apparatus- or equipment-coded CPs when requirements are extensive or when many requirements are common to several CPs. A reference to this specification is provided in the MANUFACTURING REFERENCES TABLE (see paragraph 13.07).
- (b) When the requirements are minimal, they may be placed on the CPS following the Circuit Description in the J section under the heading of "MANUFACTURING TEST REQUIREMENTS".

**13.13 Modification Indications:** Circuit pack modifications may be indicated by either of the following two methods:

- (a) **Option Letters:** Option letters are assigned independent of FS option letters and do not appear in the Option Index located in the A section

of an SD. Modifications indicated by option letters are recorded in the Record of Changes Table on the J sheet (see Fig 18).

- (b) **Line-Out Method:** When this method is used, the replacing information is shown adjacent to the lined-out information (see Fig 18). This method is used as follows:

- (1) When the electrical value of a particular component code changes from nonstandard to standard (see resistor R3 in Fig 18).
- (2) When one component is replaced by another that is electrically and mechanically interchangeable.

## 14. CIRCUIT MODULE SCHEMATICS ON AN SD

**14.01** The preferred method of documenting circuit modules (CMs) is on the circuit pack schematic on which they are used (ie, on the stand-alone CPS drawing or on the SD J section circuit figure). CMs are enclosed in boundary lines in the CP circuit figure and are designated CM1, CM2, etc. CMs are listed in the CP component list under the heading MODULE, CIRCUIT. When a CM is used on more than one CP code which is documented in the J section, the CM may be documented in the K section and is designated according to its code, eg, CMXX15. The information required to document CMs in the K section is similar to that required for CPs in the J section and is formatted in a like manner.

## 15. LOCATING INFORMATION ON THE DRAWING

**15.01 Methods Used:** The various items of information contained on the SD are readily found by means of the indexes, the sheet coordinates, and the cross-referencing arrangements furnished as part of each drawing.

The following paragraphs explain how to locate typical information.

### 15.02 FS Information:

- (a) To locate contacts of relays and other components, refer to the APP INDEX. First find the category heading of the type of component, eg, relays. Then find the designation of the particular

component in question and read across to the APP FIG column to determine in which APP FIG it is located. Next, find on which C# sheet the APP FIG is located by referring to the Sheet Index or scanning the C# sheets. When you find the APP FIG, look under the component heading and find the designation of the particular component. Then read across to the LOC column to find the FS sheet coordinates.

(b) To determine the resistance and capacitance of networks, note the number shown in the network symbol on the FS. Next, refer to the Network Values Table located in the D section CIRCUIT NOTES where the resistance and capacitance for the corresponding number can be found. The code of the network is given in the APP FIG.

(c) Leads to connecting circuits are traced by their lead designations. If a lead is being traced from circuit X to circuit Y, note in circuit X the designation of the lead and the title of the connecting circuit (circuit Y in this case). In the Lead Index of circuit Y, find the title of circuit X. Under this title find the designation of the lead and read across to the FS LOC column to find the FS coordinates.

**15.03 APP FIG Information:** To determine the complete ordering information for all components shown on the FSs, refer to the APP INDEX to determine in which APP FIGs they are located. Next, find on which C# sheets the APP FIGs are located by referring to the Sheet Index or by scanning the C# sheets of the drawing. When the APP FIGs are found, look under the component headings and find the designations of the particular component. Then read across to the CODE column to find the complete ordering information.

**15.04 SC Information:** To determine in which SC a relay, electron tube, etc, is located, refer to the SC Index if there is one. Otherwise, refer to the APP INDEX to determine in which APP FIG the component is located. Then scan the SC headings above the SC diagram to determine which APP FIG(s) they represent. If a particular SC represents the APP FIG in which the component is located, the component will be shown in that SC.

## 16. CIRCUIT DESCRIPTIONS

**16.01 Definition and Purpose:** A Circuit Description (CD) describes the operation of the cir-

cuit. It also provides engineering, operating, testing, and maintenance information that applies specifically to that circuit.

**16.02 Location of CD Information:** Each CD bears the same 5-digit number as its associated SD. Each reissue of an SD is covered by a reissue of the CD or by a CD appendix. Added connecting circuits, changed working limits, changed operating sequence, etc, are explained in the CD. Circuit Descriptions for circuit packs as covered in paragraph 13.09 are shown in the J section for each CP.

**16.03 Contents:** The information contained in a CD is arranged in sections, as follows:

(a) **Section I - General Description:** This section of a CD briefly states the purpose and gives a general description of the operation of the circuit.

(b) **Section II - Detailed Description:** This section includes details of what the circuit is intended to do and how it performs those functions. It includes a description of all features, functions, figures, and apparatus and wiring options. Option ratings are not given. The purpose of relays with core symbols such as SO, SR, etc, and any special contact sequences is also explained.

(c) **Section III - Reference Data:** This section provides the following information, in the order given:

- (1) Working Limits
- (2) Functional Designations
- (3) Functions of the Circuit
- (4) Connecting Circuits
- (5) Manufacturing Testing Requirements.

In addition to the information listed above, the following information is given, if applicable:

- (6) Alarm Information
- (7) Taking Equipment Out of Service (TEOS).

(d) **Section IV - Reasons for Reissue:** This section describes and gives the reasons for changes made on reissues of the drawing.

## SECTION 005-109-101

**16.04 Abbreviated CDs:** A CD containing limited information is prepared on a temporary basis when project schedules make it impossible to initially prepare a complete CD to accompany the release of the SD. However, a complete CD is prepared and released with a later reissue of the SD. Information in an abbreviated CD is as follows:

(a) **Section I - General Description**

(b) **Section III - Reference Data**

(1) Working Limits

(2) Connecting Circuits.

### REASONS FOR REISSUE

1. The BSP title was changed from "Detached-Contact-Type Schematic Drawings (SDs) Descriptive Information" to "Circuit Schematic Drawings (SDs) Descriptive Information." The specific reference to detached-contact-type schematics was eliminated to provide a more generic title to accommodate the SD- drawing as it has evolved over the years.
2. Part 1, General, was revised to indicate the drawing number identification scheme of an SD and to remove exclusive reference to switching systems. Paragraphs 1.04 through 1.10 were transferred to Part 2.
3. Part 2, Evolution of the SD- Drawing, which incorporates former paragraphs 1.04 through 1.10 of Part 1, was created to provide an explanation of the evolution of the SD- drawing to its present format. Included in this explanation is the addition of Block Diagrams, Circuit Pack Schematics, and Circuit Module Schematics to the existing groups of SD- drawing information and the partitioning requirements of the SD into "Engineering and Manufacturing Only" (E&M Only) and "Operation and Maintenance" (O&M) categories. A specific symbol, '#', used to identify the O&M information is explained in detail.
4. Part 3, Arrangement of Information on SD- Drawings, formerly Part 2, was revised to:
  - (a) Include an explanation of the preparation and arrangement of information on an SD- drawing due to the latest partitioning requirements of the information into E&M Only and O&M categories
  - (b) Include the date on which the partitioning requirements became effective
  - (c) Include a description of the accessory information (drawing identification information) that appears on SD- drawing sheets
  - (d) Include an explanation of the method used to insert sheets in a drawing
  - (e) Explain three groups of information, ie, Block Diagrams, Circuit Pack Schematics, and Circuit Module Schematics
  - (f) Describe the method used to number sheets
  - (g) Expand the explanation of coordinate locations.
5. Part 4, Indexes and Supporting Information, formerly Part 3, was revised to:
  - (a) Include information for listing circuit packs in the Apparatus Index
  - (b) Provide an explanation of the Lead Index Connecting Circuits Table
  - (c) Provide an explanation of the Designation Mnemonic Index
  - (d) Provide details of the expanded Option Index Table which now includes two additional columns titled **RATED ON ISSUE** and **REF NOTES**
  - (e) Describe the latest sheet index that is used on SD- drawings.
6. Part 5, Functional Schematics, formerly Part 4, was revised to:
  - (a) Provide additional information on FS symbols
  - (b) Provide reference to Section 005-108-111
  - (c) Add conventions for depicting line symbols and circuit pack symbols on FSs.
7. Part 6, Apparatus Figures, formerly Part 5, was revised to:

- (a) Include methods of representing circuit packs, component assemblies, diodes, and inductors in the Apparatus Figure (APP FIG)
  - (b) Modify the method for representing jacks, plugs, and cords in the APP FIG
  - (c) Clarify the listing of networks.
8. Part 7, Notes and General Circuit Information, formerly Part 6 was revised to:
    - (a) Include the latest arrangement of note information due to the partitioning of the SD-drawing into O&M and E&M Only categories
    - (b) Update the BSP reference.
  9. Part 8, Sequence Charts, formerly Part 7, was revised to:
    - (a) Include information for electronic circuitry sequence charts
    - (b) Update the BSP reference.
  10. Part 9, Circuit Requirements Tables, formerly Part 8, was revised to update the BSP reference.
  11. Part 11, Cabling Diagrams, formerly Part 10, was expanded to:
    - (a) Indicate the assignment and identification of connecting devices
    - (b) Indicate the use of CADs
    - (c) Provide spare terminal information
    - (d) Explain the use of distributing frame terminal strips
    - (e) Provide a list of references.
  12. Part 12, Block Diagrams, was added to explain the various types of Block Diagrams (BDs) such as FS BDs, Circuit BDs, System BDs, and System Application BDs.
  13. Part 13, Circuit Pack Schematics on an SD, was added to explain the use, format, and contents of Circuit Pack Schematics on an SD-drawing.
  14. Part 14, Circuit Module Schematics on an SD, was added to explain the use, format, and contents of Circuit Module Schematics on an SD-drawing.
  15. Part 16, Circuit Descriptions, formerly Part 12, was revised to:
    - (a) Explain the CD numbering scheme
    - (b) Explain the definition, purpose, and content of a CD
    - (c) Add information on abbreviated CDs.
  16. Fig 1 was revised to indicate the various methods of showing sheet indexes for drawings issued before and after September 1, 1980.
  17. Fig 2 was revised to indicate latest methods of showing information in the Apparatus, Lead, and Option Indexes and to show a Lead Index Connecting Circuits Table.
  18. Fig 3 was added to show a Designation Mnemonic Index.
  19. Fig 4 was revised to indicate the latest methods of showing miscellaneous information, and to add line symbols and circuit pack information.
  20. Fig 5 was revised to indicate the latest methods of showing miscellaneous information and to add examples of flat-spring relays, circuit packs, component assemblies, cords, jacks, and plugs.
  21. Fig 6 was revised to remove the TERM DESIG column.
  22. Fig 7, 9, 10, and 13 were revised to indicate the latest methods of showing column headings.
  23. Fig 11 was revised to show the latest methods of indicating resistances.
  24. Fig 16 was revised to add distributing frame terminal strips, connectors used as TSSs, and methods of showing shop and installer wiring on TSSs.
  25. Fig 17 A through D was added to show examples of Block Diagrams.
  26. Fig 18 was added to show a CPS documented in the J section.

CONTENTS	SHEET NO.	SHEET INDEX																									SHEET NO.	
		1	2	3	4	5	6	7	8	9	10	11	12	13	14	15	16	17	18	19	20	21	22	23	24	25		
SHEET INDEX SUPPORTING INFORMATION	A1	1	2	3	4	5																						A1
APPARATUS INDEX LEAD INDEX OPTION INDEX	A2	1	2	2	2	5																						A2
FS 1 - REGISTER CONTROL FS 2 - REGISTER TEST	B1	1	2	2	2	5																						B1
FS 3 - PULSE COUNTING FS 4 - DIGIT STEERING	B2	1	2	2	2	2																						B2
FS 5 - DIGIT REGISTRATION	B3	1	2	2	2	2																						B3
FS 6 - CONNECTOR SELECTION FS 7 - PLANT AND TRAFFIC REGISTERS	B4	1	2	2	2	5																						B4
FS 8 - OVERALL TIMING AND TROUBLE RELEASE FS 9 - LINK ALARM AND TROUBLE RELEASE TIMING FS 10- ALARMS	B5	1	2	3	3	5																						B5
APP FIG. 1	C1	1	2	3	4	5																						C1
CIRCUIT NOTES 101-110 WORKING LIMITS	D1	1	1	3	3	5																						D1
CIRCUIT NOTES 111 TO END EQUIPMENT NOTES INFORMATION NOTES	D2		3	3	5																							D2
SC 1 - NORMAL CALL	E1	1	1	1	1	1																						E1
SC 2 - LINK ALARM TIMING SC 3 - TROUBLE RELEASE TIMING SC 4 - STUCK REGISTER TIMING SC 5 - PERMANENT SIGNAL TIMING SC 6 - PARTIAL DIAL TIMING SC 7 - NO SENDER ATTACHED	E2	1	2	2	2	5																						E2
CKT REQ TABLES RELS 1CA-SAP	F1	1	2	3	4	5																						F1
CKT REQ TABLE SC TO END TIMING REQ TABLE	F2	1	2	2	2	2																						F2
CAD 1,2,3,4	G1	1	2	3	3	3																						G1

Fig 1A—Sheet Index for Drawings Arranged for Individual Sheet Reissue Prior to September 1, 1980

CONTENTS	SHEET NO.	SHEET INDEX	
		SHEET NO.	SHEET ISSUE NO.
SHEET INDEX SUPPORTING INFORMATION OPTION INDEX	A1	1	1
SHEET INDEX - OPERATION AND MAINTENANCE APPARATUS INDEX LEAD INDEX	A#1	1	1
FS1 CABLE RECEIVER	B#1	1	1
FS2 ENABLE VERIFY PULSER	B#2	1	1
FS3 PROTECTION SWITCHING	B#3	1	1
FS4 POWER DISTRIBUTION	B#4	1	1
FS5 GENERATOR CIRCUIT	B#5	1	1
FS6 CONTROL LOGIC CKT	B#6	1	1
APP FIG. 1,2,3	C#1	1	1
APP FIG. 4	C#2	1	1
APP FIG. 5,6	C#3	1	1
CIRCUIT NOTES EQUIPMENT NOTES INFORMATION NOTES	D1	1	1
SC1 SCAN ORDER	E#1	1	1
CIRCUIT REQUIREMENTS TABLE	F#1	1	1
CAD 1	G1	1	1
CAD 2	G2	1	1
CAD 3,4	G3	1	1
CAD 5	G4	1	1
CAD 6	G5	1	1
BD1	H#1	1	1
BD2	H#2	1	1

Fig 1B—Sheet Index for Drawings Arranged for Individual Sheet Reissue After September 1, 1980

CONTENTS	SHEET NO.
SHEET INDEX APPARATUS INDEX LEAD INDEX OPTION INDEX TRANSMISSION TEST REQ TABLE WORKING LIMITS CIRCUIT NOTES EQUIPMENT NOTES INFORMATION NOTES SUPPORTING INFORMATION	1
FS 1 - TRUNK CKT	2
FS 2 - NO. 3C OR 3CL TOLL SWBD FS 3 - NO. 1 TOLL SWBD	3
APP FIG. 1,2,3,4	4
CKT REQ TABLE CAD 1,2,3	5
SC 1 - ESTABLISHING CONNECTION SC 2 - CALL ABANDONED SC 3 - OPERATOR ANSWERS AT NO. 3C OR 3CL TOLL SWBD SC 4 - OPERATOR ANSWERS AT NO.1 TOLL SWBD	6
SC 5 - OPERATOR COLLECTS OR RETURNS COIN SC 6 - OPERATOR DISCONNECTS SC 7 - RECALLING SUBSCRIBER	7

Fig 1C—Sheet Index Not Arranged for Individual Sheet Reissue

SUPPORTING INFORMATION	
CATEGORY	NO.
EQUIPMENT DESIGN REQ	J34000
EQUIPMENT DRAWING	J34000A J34000B
SYSTEMS BLOCK DIAGRAM	SD-1A002

Fig 1D—Supporting Information Table

APPARATUS INDEX			
EQPT LOC	LOCATION		
	FS	APP FIG.	EQPT
PACKS, CIRCUIT			
032-01	2D5	3	
032-03	2C5	3	
032-05	2C6	3	
032-07	2D8	6	
034-01	5C6	2	
034-03	1C8	2	
034-07	6D0	2	
034-11	1B3	1	
034-13	2D1	5	
034-15	2F3	2	
034-17	8C0	2	
034-21	7F4	4	
034-23	4G0	4	
034-25	4G7	4	
034-29	3F4	2	

DESIG	LOCATION		
	FS	APP FIG.	EQPT
PACKS, CIRCUIT			
AA	3F4	2	034-29
LMO	2C5	3	032-03
LM1	2C6	3	032-05
P	7F4	4	034-21
PVE	2D5	3	032-01
RP1	6D0	2	034-07
RP2	2D1	5	034-13
TLO	4G0	4	034-23
TL1	4G7	4	034-25

Fig 2A—Apparatus Index

LEAD INDEX CONNECTING CIRCUITS	
CIRCUIT TITLE	CKT LEAD INDEX LOC
ALL MARKERS BUSY OR ALL TRANSVERTERS BUSY CKT AUTOMATIC MONITOR REGISTER AND SENDER TEST CKT AUTOMATIC PROGRESSION TRUNK TEST CKT	18A2 18B2 18E2
CENTREX TRAFFIC REGISTER TRANSLATOR CKT	18G2
FOREIGN AREA TRANSLATOR CONNECTOR CKT	18A4
REGISTER PRIORITY LINK CKT	20E1
SENDER CKT SERVICE OBSERVING REGISTER CONNECTOR CKT SERVICE OBSERVING TRUNK SELECTION & CONTROL CKT	20G1 20A2 20C2
TRAFFIC REGISTER CKT TRAFFIC USAGE RECORDER CKT	20F2 20A3

Fig 2B—Lead Index Connecting Circuits Table

LEAD INDEX		
DESIG	LOCATION	
	FS	CAD
CALL STORE SELECTOR 0 CKT CALL STORE SELECTOR 1 CKT PROGRAM STORE DATA CKT SIGNAL COMPARATOR CKT		
0A0	8E2	5B7
0B0	8E2	5B7
0C0	8E2	5B7
0D0	8E2	5B7
0E0	8E2	5B7
0F0	8E2	5B7
CENTRAL PULSE DISTRIBUTION CKT		
0EN02N	6A5	3D4
0EN02P	6A5	3D4
0EN12N	6A5	3D4
0EN12P	6A5	3D4
1EN012N	7A5	4D4
1EN012P	7A5	4D4
1EN12N	7A5	4D4
1EN12P	7A5	4D4
COMMUNICATION BUS TERMINATING CKT		
0A000N	1B6	1E0
0A000P	1B6	1E0
0A001N	1B6	1E0
0A001P	1B6	1E0
0A002N	2B6	2E0
0A002P	2B6	2E0
0A003N	2B6	2E0
0A003P	2B6	2E0
0A004N	3B6	3E0
0A004P	3B6	3E0
0A005N	3B6	3E0
0A005P	3B6	3E0
AD12N	1B0	4E0
AD12P	1B0	4E0
AD13N	1B0	4E0
AD13P	1B0	4E0
AD14N	2B0	1E0
AD14P	2B0	1E0
AD15N	2B0	1E0
AD15P	2B0	1E0
AD16N	3B0	2E0
AD16P	3B0	2E0
AD17N	3B0	2E0
AD17P	3B0	2E0
DIGITAL TAPE RECORDER CKT		
RO	5G5	
R1	5G5	
RAD	5G5	
RDD	5G5	
RE0	5G5	

Fig 2C—Lead Index

OPTION INDEX			
APP OR WRG	RATED ON ISSUE	REF NOTES	LCCATION
Z	STD 1		2A4, 2A5, 2A6
Y	STD 1		2A4, 2A5, 2A6
X	STD 1		APP FIG. 3, 2F4, 2F6
W	STD 1		APP FIG. 3, 2F4, 2F6

Fig 2D—Option Index

DESIGNATION MNEMONIC INDEX

MNEMONIC	FS NO.	DEFINITION
AASCSA	54	AUXILIARY UNIT SEQUENCER TO CS ADDRESS BUS
AASPKA	65	AUXILIARY UNIT STORE ADDRESS REGISTER - PARITY BIT
AASR	65	AUXILIARY UNIT STORE ADDRESS REGISTER - READ BIT
AASW	65	AUXILIARY UNIT STORE ADDRESS REGISTER - WRITE BIT
AASXX	65	AUXILIARY UNIT STORE ADDRESS REGISTER BIT XX (0 THRU 21)
CSMC	52	CS CONTROL MODE BIT
CSMM	52	MAINTENANCE MODE BIT
DARCSA	54	SELECT DAR TO CS ADDRESS BUS
DARXX	25	DATA ADDRESS REGISTER BIT XX (00-24)
MTCCS	105	CALL STORE MAINTENANCE MODE CONTROL
PAP	23	PROGRAM ADDRESS PARITY
PARCSA	54	SELECT PAR TO CSA
PARXX	23	PROGRAM ADDRESS REGISTER BIT XX (00-23)
READ	52	READ BIT ON ADDRESS
SCCSA	54	SELECT SC TO CS ADDRESS BUS
SCP	35	STACK COUNTER PARITY
SCXX	35	STACK COUNTER BIT XX (0 THRU 5)
WRITE	52	WRITE BIT ON ADDRESS

Fig 3—Designation Mnemonic Index

**NOTES**

1. AN FS SHOWS THE INTERCONNECTIONS REQUIRED IN A CIRCUIT FOR A FUNCTION OR A GROUP OF FUNCTIONS.
2. ALL WIRING, BOTH NONOPTIONAL AND OPTIONAL, AND ALL APPARATUS OPTIONS INVOLVED IN WIRING, ARE SHOWN IN THE FS.
3. THE SYMBOLS USED IN FSs ARE ILLUSTRATED AND DESCRIBED IN THE FIGURE; IF NOT SPECIFICALLY COVERED HEREIN, THE SYMBOLS FOR SCHEMATIC DRAWINGS ILLUSTRATED AND DESCRIBED IN BSP SECTION 005-108-111 ARE EMPLOYED.
4. A SYMBOL MAY BE TURNED IN ANY DIRECTION WITHOUT AFFECTING ITS MEANING
5. EACH SYMBOL IS IDENTIFIED BY THE FUNCTIONAL DESIGNATION OF THE APPARATUS IT REPRESENTS. THE FUNCTIONAL DESIGNATION IS SHOWN IN HEAVY LETTERING WHEN ASSOCIATED WITH ACTIVE APPARATUS SUCH AS RELAY COILS, TUBES, ETC. WHEN ASSOCIATED WITH DETACHED CONTACTS OF RELAYS, JACKS, KEYS, ETC., AND WITH CAPACITORS AND RESISTORS, THE FUNCTIONAL DESIGNATIONS ARE SHOWN IN LIGHT LETTERING.
6. AS ILLUSTRATED IN THIS FIGURE, A RELAY COIL IS DEPICTED BY A RECTANGLE. NOTE THAT:
  - (A) THE RELAY WINDING RESISTANCE OHM SYMBOL IS NOT SHOWN.
  - (B) RELAYS WITH PARTICULAR OPERATING FEATURES SUCH AS SLOW OPERATE, SLOW RELEASE, POLAR, ETC., HAVE AN ABBREVIATION WITHIN THE RECTANGLE SYMBOL THAT COVERS THE PARTICULAR OPERATING FEATURE WHICH APPLIES.
  - (C) INNER-END SYMBOLS ARE NOT SHOWN FOR SINGLE-WOUND AND POLAR RELAYS; THEY ARE SHOWN FOR ALL OTHER TYPES OF RELAYS.
7. HEAVY LINES ARE USED FOR TALKING AND FUNDAMENTAL LEADS; ALL OTHER LEADS ARE SHOWN IN LIGHT LINES.
8. SHORT DASH LINES ARE USED TO INDICATE CIRCUIT PATH CONTINUITY THROUGH LIKE INTERMEDIATE CIRCUIT ELEMENTS, AND ALSO TO INDICATE OMITTED SECTIONS OF AN EXTERNAL CIRCUIT.
9. DETACHED PARTS OF APPARATUS COMPONENTS ARE IDENTIFIED BY BOTH THE FUNCTIONAL DESIGNATION OF THE APPARATUS TO WHICH THEY BELONG AND BY THEIR TERMINAL OR ELEMENT IDENTIFIERS.
10. DOUBLE-LINE BOXES ARE USED TO ENCLOSE INFORMATION FOR COMPLETING CIRCUIT PATHS ON AN FS. DETAILED INFORMATION WHICH IS SHOWN ELSEWHERE ON THE CIRCUIT OR IN ANOTHER CIRCUIT IS SHOWN WITHIN THE DOUBLE-LINE BOXES. THIS INFORMATION IS NOT INTENDED FOR WIRING PURPOSES.
11. UNASSIGNED CONTACTS OF RELAYS ARE NOT SHOWN IN THE FS.
12. AN FS IS USUALLY GIVEN A TITLE, WHICH IS SHOWN BELOW THE FS NUMBER.
13. COORDINATES ARE USED TO LOCATE THE POSITION OF APPARATUS ON EACH SHEET CONTAINING FSs. LETTERS, EVENLY SPACED, ARE PLACED FROM TOP TO BOTTOM ON THE LEFT- AND RIGHT-HAND EDGES OF THE SHEET. NUMBERS, EVENLY SPACED, ARE PLACED FROM LEFT TO RIGHT ON THE TOP AND BOTTOM EDGES OF THE SHEET. THUS, COORDINATE B5 MEANS HORIZONTAL LINE B, VERTICAL COLUMN 5.
14. THE MAKE, BREAK, AND TRANSFER CONTACTS OF RELAYS THAT ARE NORMALLY OPERATED ARE SHOWN IN THE SAME MANNER AS THOSE OF RELAYS THAT ARE NORMALLY UNOPERATED. HOWEVER, AT THE CORE AND CONTACTS IN THE FS AND AT THE CODE IN THE APP FIG. FOR A NORMALLY OPERATED RELAY AN ASTERISK (OR EQUIVALENT MARK) SHALL BE SHOWN. THE ASTERISK SHALL BE EXPLAINED IN A SHEET NOTE AS FOLLOWS:
 

\* RELAY NORMALLY ENERGIZED AT ALL TIMES.

**SYMBOLS**

SYMBOL	MEANING
	BATTERY. NEGATIVE SIDE OF 48 VOLT POSITIVE GROUNDED BATTERY. THE LETTER (WHEN USED) DESIGNATES THE FUSE THROUGH WHICH BATTERY IS FED TO THE APPARATUS. WHEN OTHER THAN -48 VOLT BATTERY IS REQUIRED, THE DESIRED VOLTAGE AND POLARITY IS SHOWN IN PLACE OF -48.
	GROUND. THE LETTER (WHEN USED) DESIGNATES THE GROUND BUS TO WHICH THE LEAD IS CONNECTED.
	SINGLE-WOUND RELAY OR COIL. SG IS THE FUNCTIONAL DESIGNATION. 250 IS THE RESISTANCE OF THE WINDING IN OHMS, AND 5T AND 5B IDENTIFY THE WINDING TERMINALS. SO INDICATES THAT RELAY IS SLOW OPERATE.
	MULTI-WOUND RELAY OR COIL. (SHOWN IN EITHER MANNER) HM IS THE FUNCTIONAL DESIGNATION. P AND S ARE PRIMARY AND SECONDARY WINDINGS OF 2.5K OHMS EACH, AND 4BF, 7TF, 5BR AND 8TR IDENTIFY THE WINDING TERMINALS. THE INNER ENDS OF THE WINDINGS ARE IDENTIFIED BY SOLID CIRCULAR SEGMENTS WHICH INDICATE POLARITY SINCE THE INNER ENDS ARE USUALLY CONNECTED TO THE GROUNDED FRAMES. INNER ENDS ARE NOT INDICATED FOR SINGLE OR MULTI-WOUND POLARIZED RELAYS BECAUSE BOTH + AND - SIGNS ARE SHOWN.
	MAKE CONTACT OF A RELAY HAVING TOP AND BOTTOM SPRING PILE UPS; OPEN WHEN RELAY IS UNOPERATED, CLOSED WHEN RELAY IS OPERATED. SG IS THE FUNCTIONAL DESIGNATION OF THE RELAY AND 1 AND 2T IDENTIFY THE NUMBER 1 AND 2 SPRINGS IN THE TOP PILE-UP.
	MAKE CONTACT OF A RELAY HAVING CONTACTS LOCATED IN DEFINITE NUMBERED POSITIONS ON THE RELAY STRUCTURE. OPEN WHEN RELAY IS UNOPERATED, CLOSED WHEN RELAY IS OPERATED. HM IS THE FUNCTIONAL DESIGNATION OF THE RELAY AND 1 IDENTIFIES THE FIXED SPRING OF THE NUMBER 1 SET OF CONTACTS.
	BREAK CONTACT OF A RELAY HAVING TOP AND BOTTOM SPRING PILE-UPS. CLOSED WHEN RELAY IS UNOPERATED, OPEN WHEN RELAY IS OPERATED. SG IS THE FUNCTIONAL DESIGNATION OF THE RELAY AND 3 AND 4B IDENTIFY THE NUMBER 3 AND 4 SPRINGS IN THE BOTTOM PILE-UP.
	BREAK CONTACT OF A RELAY HAVING CONTACTS LOCATED IN DEFINITE NUMBERED POSITIONS ON THE RELAY STRUCTURE. CLOSED WHEN RELAY IS UNOPERATED, OPEN WHEN RELAY IS OPERATED. HM IS THE FUNCTIONAL DESIGNATION OF THE RELAY AND 5 IDENTIFIES THE FIXED SPRING OF THE NUMBER 5 SET OF CONTACTS.
	TRANSFER CONTACTS. THESE THREE-SPRING COMBINATIONS ARE SHOWN IN A VARIETY OF WAYS, AS ILLUSTRATED. CONTACT NUMBERS AND LETTERS ARE USED IN THE SAME MANNER AS EXPLAINED ABOVE FOR MAKES AND BREAKS: IN THE CASE OF THE HM RELAY, FOR EXAMPLE, THE SINGLE-NUMBER IS SHOWN FOR THE FIXED SPRING. THE CONTACT SEQUENCE, SUCH AS MAKE-BREAK (CONTINUITY) AND BREAK-MAKE (TRANSFER), IS COVERED IN THE APP FIG. DOTS USUALLY ARE NOT SHOWN AT JUNCTION POINTS OF THE MAKE AND BREAK, EXCEPT AS ILLUSTRATED ON SHEET 2 OF THIS FIGURE, ITEM 28, COVERING SYMMETRIC CIRCUITS.
	DOUBLE TRANSFER CONTACTS. THIS TYPE OF SPRING COMBINATION MAY BE SHOWN IN VARIOUS WAYS AS ILLUSTRATED. IT CONSISTS OF 2 MAKE CONTACTS AND 2 BREAK CONTACTS ALL WITH A COMMON ARMATURE. A IS THE FUNCTIONAL DESIGNATION OF THE RELAY AND NUMBERS 1, 2, 4, AND 5 IDENTIFY THE FIXED SPRINGS AND NUMBER 3 IDENTIFIES THE MOVABLE SPRING.

Fig 4—Methods of Showing Information on a Functional Schematic



**SYMBOLS (CONT.)**

SYMBOL	MEANING
<p>11. </p>	<p><b>INTERRUPTER AND OFF-NORMAL CONTACTS.</b> AST and TA ARE THE FUNCTIONAL DESIGNATIONS OF THE APPARATUS AND 3 AND 4 AND 1 AND 2 IDENTIFY THE SPRINGS. O.N. AND INT INDICATE OFF-NORMAL AND INTERRUPTER RESPECTIVELY.</p>
<p>12. </p>	<p><b>LEVER TYPE KEY CONTACTS.</b> TLK IS THE FUNCTIONAL DESIGNATION OF THE KEY, AND 1 AND 2A IDENTIFY THE NUMBERS 1 AND 2 SPRINGS IN THE "A" QUADRANT. L OR NL PRECEDING THE WORD KEY DISTINGUISH BETWEEN LOCKING AND NON-LOCKING KEYS. THE CONTACT CONFIGURATION OF THE KEY AND THE NUMBER AND QUADRANT ASSIGNMENTS ARE SHOWN IN THE APP FIG. (SEE PARAGRAPH 5.26 OF BSP TEXT.)</p>
<p>13. </p>	<p><b>PUSH- AND TURN-BUTTON KEY CONTACTS.</b> RING IS THE FUNCTIONAL DESIGNATION OF THE KEY, AND 1 AND 2 IDENTIFY THE NUMBERS 1 AND 2 SPRINGS. L OR NL PRECEDING THE WORD KEY DISTINGUISH BETWEEN LOCKING AND NON-LOCKING KEYS. THE CONTACT CONFIGURATION OF THE KEY AND THE NUMBER ASSIGNMENT IS SHOWN IN THE APP FIG. (SEE PARAGRAPH 5.26 OF BSP TEXT.)</p>
<p>14. </p>	<p><b>JACK SPRINGS.</b> THE TIP, RING AND SLEEVE WITH WHICH THE PLUG MAKES CONTACT MAY BE SHOWN AS ILLUSTRATED. THE PARTS OF THE JACK ARE NUMBERED TO COORDINATE THEM IN THE FS AND APP FIG.</p>
<p>15. </p>	<p><b>JACK CONTACTS.</b> CONTACTS OF JACKS MAY BE DETACHED AS ILLUSTRATED. L IS THE FUNCTIONAL DESIGNATION OF THE JACK; 5 AND 6 IDENTIFY BREAK CONTACT SPRINGS; 7 AND 8 IDENTIFY MAKE CONTACT SPRINGS; 2, 3, AND 4 IDENTIFY TRANSFER CONTACT SPRINGS.</p>
<p>16. </p>	<p><b>LEADS</b> HB LEAD TO SHEET 3, AT LOCATION COORDINATE C4.</p>
<p>17. </p>	<p><b>TROUBLE RECORD INFORMATION.</b> A SOLID TRIANGLE (▼) BELOW A LEAD INDICATES THAT THE LEAD IS USED AS A TROUBLE RECORD LEAD AND CONTROLS THE PERFORATION OF A TROUBLE RECORD CARD, THE LIGHTING OF A LAMP IN A TROUBLE INDICATOR, OR THE PRINTING OF A NOTATION ON A TROUBLE TICKET.</p> <p>IN THE ILLUSTRATION, THE TCU9 LEAD DESIGNATION AGREES WITH THE DESIGNATION OF THE TROUBLE PUNCH OR LAMP. THE TMIX LEAD DESIGNATION DOES NOT AGREE WITH THE PUNCH OR LAMP DESIGNATION. THEREFORE, THE PUNCH OR LAMP DESIGNATION, TM, IS SHOWN ADJACENT TO THE SOLID TRIANGLE.</p> <p>THE TROUBLE TICKETER RECORDS TROUBLE BY PRINTING CHARACTERS ON A TICKET. THE LEADS THAT CONTROL THE PRINTING OF THE CHARACTERS ARE SHOWN ON THE FS AS ILLUSTRATED. THERE IS NO SIMILARITY BETWEEN THE CHARACTERS PRINTED ON THE TICKET AND THE LEAD DESIGNATIONS. THEREFORE, INFORMATION WHICH RELATES THE CHARACTERS TO THE LEAD DESIGNATIONS IS GIVEN IN TABULAR FORM AS AN INFORMATION NOTE ON THE CIRCUIT WHICH DIRECTLY CONNECTS TO THE TROUBLE TICKETER OR CONNECTS TO A CIRCUIT WHICH ITSELF DIRECTLY CONNECTS TO THE TROUBLE TICKETER.</p>
<p>18. </p>	<p><b>TERMINALS</b> <b>CONNECTING BLOCK TERMINAL.</b> THIS ILLUSTRATES TERMINAL 7 ON THE B TERMINAL STRIP. <b>CROSS-CONNECTION TERMINAL.</b> JPL0 IS THE FUNCTIONAL DESIGNATION. THE LOCATION OF THE TERMINAL IS GIVEN IN THE CROSS-CONNECTION INFORMATION.</p>
<p>19. </p>	<p><b>CONNECTOR TERMINALS.</b> MALE AND FEMALE CONTACTS OF MATING CONNECTORS. THE FUNCTIONAL DESIGNATION A AND THE CONTACT TERMINAL NUMBER 6 ARE SHOWN ONCE WHERE THE TWO CONNECTORS ARE SHOWN IN ONE LOCATION IN THE FS. WHEN THE MATING CONNECTORS ARE SEPARATED THE FUNCTIONAL DESIGNATION AND THE CONTACT TERMINAL NUMBER ARE REPEATED AT EACH CONNECTOR.</p>

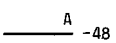
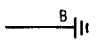
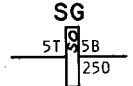
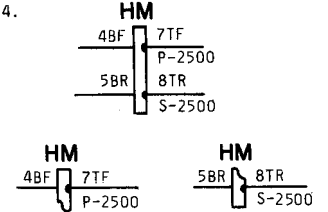
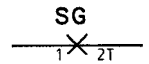
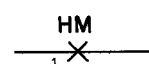
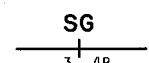
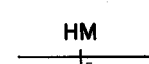
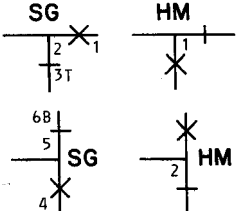
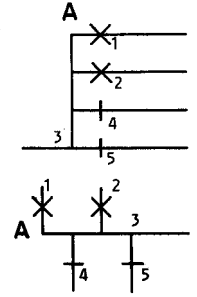
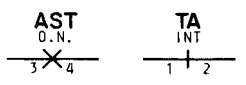
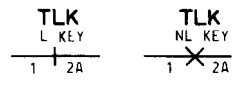
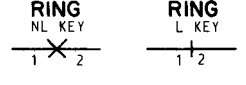
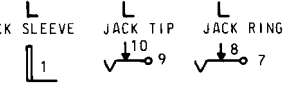
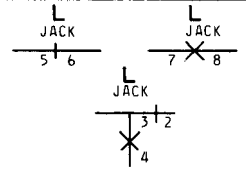
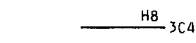
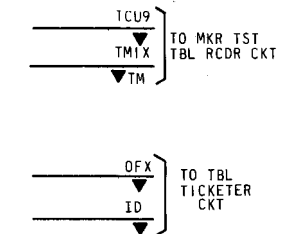
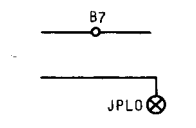
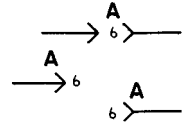
SYMBOL	MEANING										
<p>20. </p>	<p><b>MULTIPLE CONNECTOR.</b> THE MULTIPLE SYMBOL MAY BE ACCOMPANIED BY AN EXPLANATORY NOTE. IN THIS ILLUSTRATION THE PS AND PD LEADS FROM ONE TRAFFIC REGISTER CIRCUIT CONNECT TO ALL OTHER DP SENDER CIRCUITS.</p> <p>WHEN THE MULTIPLE SYMBOL IS NOT ACCOMPANIED BY AN EXPLANATORY NOTE, BUT IS PLACED CLOSE TO A SYMBOL REPRESENTING MORE THAN ONE CIRCUIT ELEMENT TERMINAL, IT INDICATES THAT ALL OF THESE TERMINALS ARE MULTIPLIED. IN THIS ILLUSTRATION, THE MULTIPLE SYMBOL INDICATES CONNECTION TO 5T OF RELAYS CD(A), CD(B), AND CD(C). THE TERMINAL TO WHICH DIRECT BATTERY OR DIRECT GROUND IS CONNECTED DOES NOT CARRY THE MULTIPLE SYMBOL.</p>										
<p>21. </p>	<p><b>CONTACT PROTECTION NETWORK.</b> THE NUMBER WITHIN THE RECTANGLE REFERS TO THE CORRESPONDING ENTRY IN THE NETWORK VALUE TABLE (CKT NOTE) WHICH GIVES THE VALUES OF THE RESISTOR AND CAPACITOR THAT COMPRISE THE NETWORK. THE SYMBOL AT THE LEFT IS FOR A TWO-TERMINAL OR A FOUR-TERMINAL NETWORK; THE OTHER SYMBOL IS FOR A THREE-TERMINAL NETWORK.</p>										
<p>22. </p>	<p><b>ROTARY SWITCH OR SELECTOR.</b> FOR SIMPLICITY, THE TERMINALS ARE ARRANGED IN A LINE AND ONE TERMINAL SYMBOL MAY REPRESENT A NUMBER OF TERMINALS, AS INDICATED BY THE PLURAL NUMBERING.</p> <p>DCK IS THE FUNCTIONAL DESIGNATION. SEL IDENTIFIES THE APPARATUS AS A SELECTOR. THE ARCS OF THE BANK ARE IDENTIFIED AS ARC 1, ARC 2, ETC. THE TYPE OF BRUSH IS SHOWN AS BRDG OR NONBRIDGING NBRDG. THE NUMBERS (OR LETTERS) AT THE ARROWHEADS REPRESENT THE POSITION DESIGNATIONS OF THE SELECTOR. THE NUMBERS AT THE TERMINALS IDENTIFY THE TERMINALS OF THE ARC OF THE BANK. THE TERMINAL DESIGNATED ALL REPRESENTS THE WIPER AND INDICATES THAT THE WIPER MAKES CONTACT IN ALL POSITIONS OF THE SELECTOR. THUS WHEN THE INDEX WHEEL INDICATES POSITION 2, THERE IS A CIRCUIT PATH THROUGH THE WIPER TO TERMINAL 2. WHEN THE INDEX WHEEL INDICATES POSITION 10, THERE IS A CIRCUIT PATH THROUGH THE WIPER TO TERMINALS 10, 11, 12, AND 15.</p> <p>TST AND FR ARE THE FUNCTIONAL DESIGNATIONS. SW INDICATES THAT THE APPARATUS IS A SWITCH. THE SECTIONS OF THE SWITCH, IF MORE THAN ONE, ARE INDICATED BY SECT 1, SECT 2, ETC. SECTION 1 IS THE SECTION NEAREST THE KNOB. WHEN THERE IS MORE THAN ONE CIRCUIT ON A SIDE OF A SECTION EACH CIRCUIT IS IDENTIFIED AS CKT A, CKT B, ETC. WHEN A SECTION HAS A CIRCUIT OR CIRCUITS ON BOTH SIDES, FRONT INDICATES THE SIDE NEAREST THE KNOB. THE LETTERS (OR NUMBERS) AT THE ARROWHEADS REPRESENT THE SWITCH DESIGNATION OF THE POSITION OF THE SWITCH AT WHICH THE CONTACT IS MADE. THE NUMBERS AT THE TERMINALS IDENTIFY THE CONTACT TERMINALS WHICH ARE NUMBERED WITH THE SWITCH VIEWED FROM THE WIRING SIDE. THE POSITION DESIGNATION ALL INDICATES THAT CONTACT IS MADE IN ALL POSITIONS OF THE SWITCH. THUS WHEN THE TST SWITCH IS IN THE OFF POSITION THERE IS A CIRCUIT PATH FROM TERMINAL 5 TO TERMINAL 1. WHEN THE SWITCH IS IN THE FAST POSITION, THERE IS A CIRCUIT PATH FROM TERMINAL 5 TO TERMINAL 3. WHEN THE FR SWITCH IS IN THE 100 POSITION, THERE IS A CIRCUIT PATH FROM TERMINAL 1 TO TERMINAL 2. WHEN THE SWITCH IS IN POSITION 150, THERE IS A CIRCUIT PATH FROM TERMINAL 2 TO TERMINAL 3.</p> <p>IN SOME CASES THE SWITCH POSITION DESIGNATIONS CANNOT BE CONVENIENTLY SHOWN AT THE SWITCH SYMBOL. IN THESE CASES A TABLE OR SHEET NOTE MAY BE USED TO INDICATE THE ASSOCIATED CIRCUIT PATHS AND SWITCH POSITIONS.</p>										
<p></p>	<p><b>TST</b> SW SECT 1(FRONT) CKT A</p>										
<p></p>	<p><b>FR</b> SW</p>										
<table border="1"> <thead> <tr> <th>POSITION NUMBER</th> <th>POSITION DESIGNATION</th> </tr> </thead> <tbody> <tr> <td>1</td> <td>OFF</td> </tr> <tr> <td>2</td> <td>ADJ POT</td> </tr> <tr> <td>3</td> <td>TEST MEAS</td> </tr> <tr> <td>4</td> <td>PULSE TEST</td> </tr> </tbody> </table>	POSITION NUMBER	POSITION DESIGNATION	1	OFF	2	ADJ POT	3	TEST MEAS	4	PULSE TEST	
POSITION NUMBER	POSITION DESIGNATION										
1	OFF										
2	ADJ POT										
3	TEST MEAS										
4	PULSE TEST										
<p>23. </p>	<p><b>AMA READER CONTACTS</b> <b>READING CONTACT.</b> CONTACT CLOSURE WHEN CAM-DRIVEN SENSING PIN FINDS PERFORATION IN TAPE. WHEN TAPE IS NOT PERFORATED, PIN TRAVEL IS BLOCKED AND CONTACT CLOSURE IS PREVENTED.</p> <p><b>CONTROL CONTACTS.</b> BREAK CONTACT ILLUSTRATED AT LEFT, MAKE CONTACT AT RIGHT. THE MOVING SPRING OF THE CAM-DRIVEN INTERRUPTER CONTACT IS ILLUSTRATED ABOVE THE CONTACTS.</p>										
<p>24. </p>	<p><b>ALARM TYPE FUSE.</b> A IS THE FUNCTIONAL DESIGNATION, IF REQUIRED, OF THE FUSE. THE FUSE CONTACT MAKES WHEN THE FUSE OPERATES CONNECTING THE SOURCE OF POWER TO THE ALARM CIRCUIT.</p>										

Fig 4—Methods of Showing Information on a Functional Schematic (Contd)

SYMBOLS (CONT.)

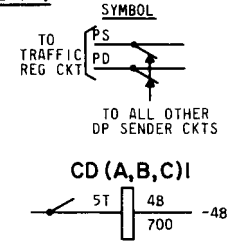
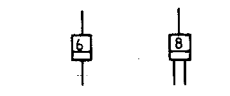
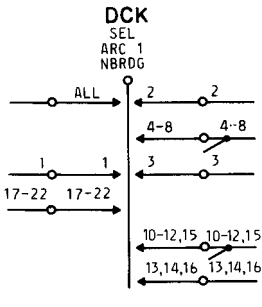
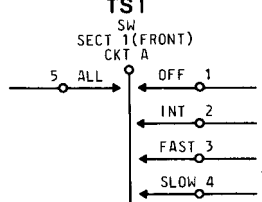
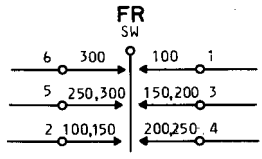
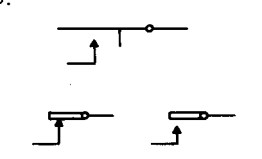
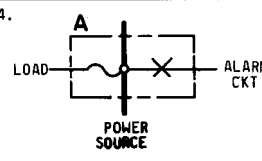
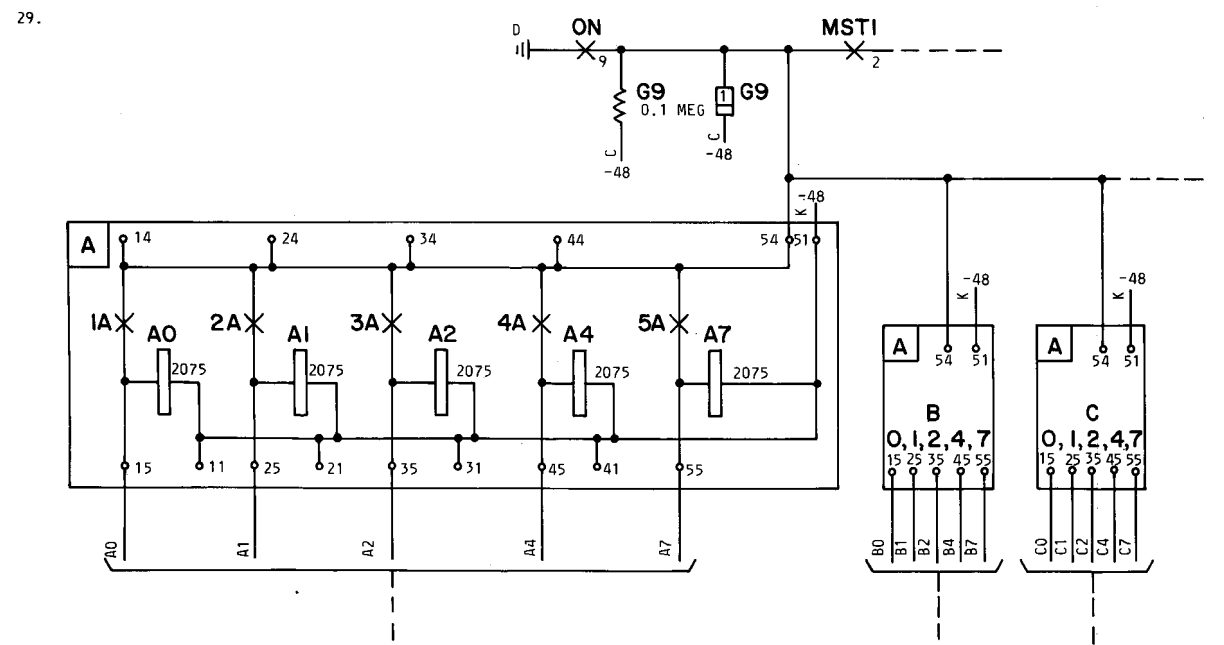
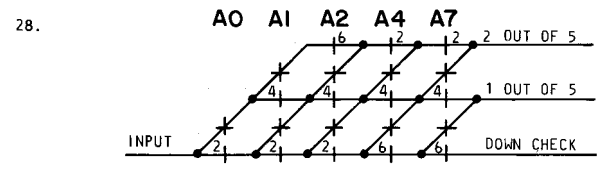
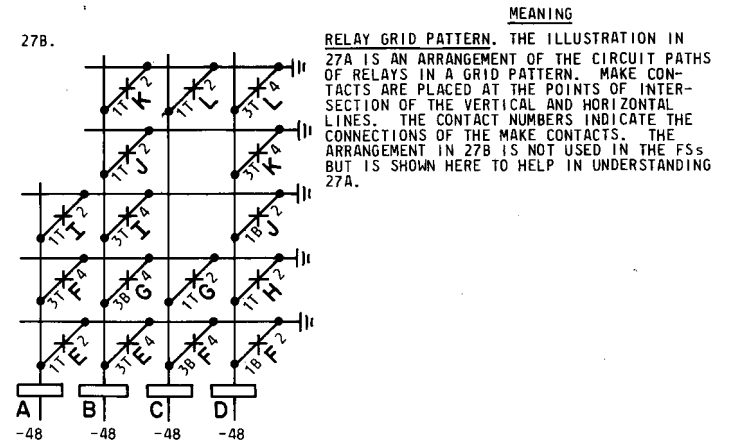
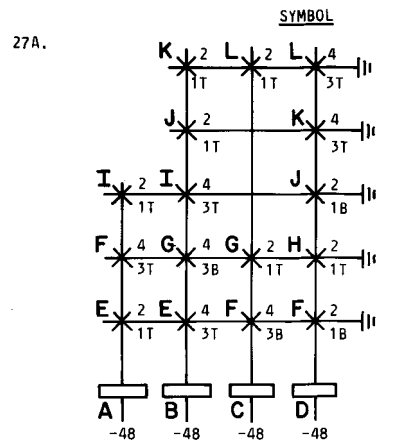
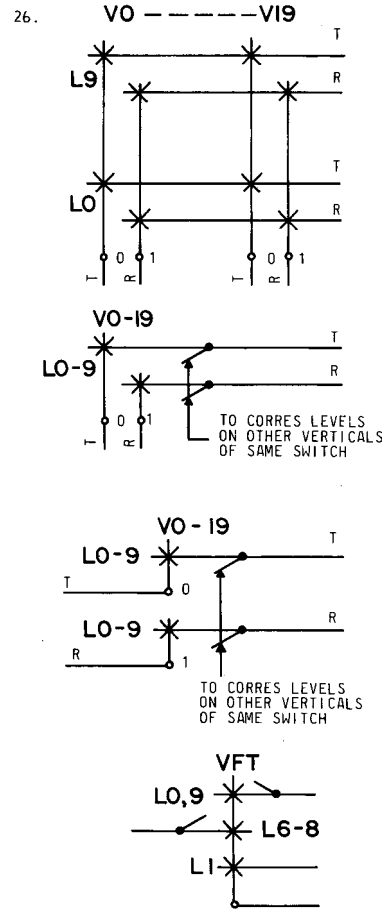
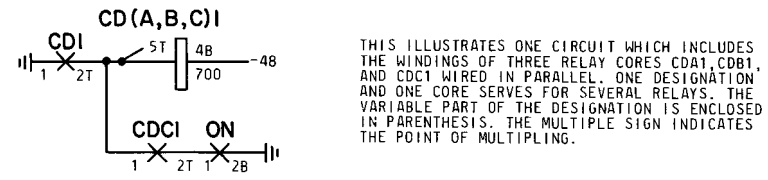
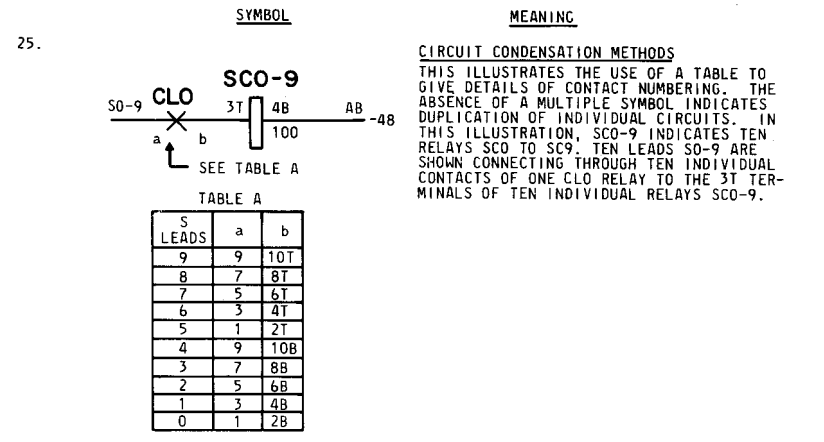
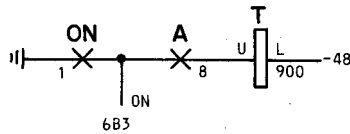
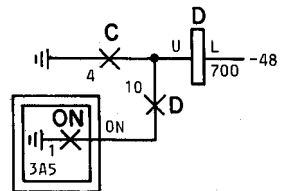
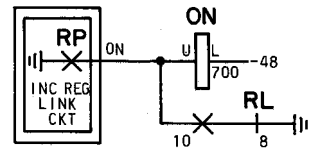

Fig 4—Methods of Showing Information on a Functional Schematic (Contd)

**SYMBOLS (CONT.)**

30.

SYMBOL	MEANING
	<p><b>EXTERNAL CIRCUIT INFORMATION</b></p> <p>A DOUBLE-LINE BOX IS USED TO ENCLOSE CIRCUIT INFORMATION REPEATED TO AVOID THE NECESSITY OF REFERRING TO OTHER SHEETS OF THE DRAWING OR TO ANOTHER CIRCUIT DRAWING. WHEN ALL THAT IS REQUIRED IS A GENERAL UNDERSTANDING OF A CIRCUIT PATH, THE INFORMATION SHOWN WITHIN A DOUBLE-LINE BOX MAY BE INCOMPLETE, SINCE ONLY SUFFICIENT DETAILS ARE INCLUDED TO PORTRAY THE COMPLETED CIRCUIT PATH. ALSO, THE INFORMATION SHOWN IS NOT INTENDED FOR WIRING PURPOSES, SINCE IT IS REPEATED FROM EITHER ANOTHER FS OF THE SAME CIRCUIT OR FROM ANOTHER CIRCUIT.</p> <p>THE NUMBER 1 CONTACT OF THE ON RELAY PROVIDES A LOCKING GROUND FOR RELAYS IN TWO DIFFERENT FS. AT THIS APPEARANCE THE CONTACT IS NOT ENCLOSED IN A DOUBLE-LINE BOX BUT REFERENCE (6B3) IS MADE TO THE OTHER APPEARANCES WHERE A DOUBLE-LINE BOX IS EMPLOYED. ONLY THE LOCATION OF THE UNENCLOSED APPEARANCE IS LISTED IN THE APP FIG.</p>
	<p>AT THIS APPEARANCE THE DOUBLE-LINE BOX ENCLOSES THE PART OF THE CIRCUIT THAT IS REPEATED; IN THIS CASE THE NUMBER 1 CONTACT OF THE ON RELAY. REFERENCE (3A5) IS MADE TO THE LOCATION OF THE UNENCLOSED APPEARANCE.</p>
	<p>IN THIS ILLUSTRATION, THE DOUBLE-LINE BOX IS USED TO EXTEND THE CIRCUIT PATH INTO ANOTHER CIRCUIT; IN THIS CASE, THE ON RELAY IS OPERATED OVER LEAD ON TO THE INCOMING REGISTER LINK CIRCUIT BY THE RP RELAY OF THE LINK. THE INFORMATION IN THE DOUBLE-LINE BOX IS NOT NECESSARILY COMPLETE AND CONTACT NUMBERS MAY BE OMITTED.</p>

31.

USE OF LINE	LINE THICKNESS
MAIN OR TRANSMISSION PATHS (TALK & TLG), BUS BAR CHARGE & DISCHARGE LEADS	THICK
DIVISION BETWEEN FIG. OFF-NORMAL GROUND	THICK
OFF-NORMAL BATTERY BOUNDARY OF MECHANICAL GROUPING STUBS	THICK
SEQUENCE SWITCH ROTARY MAGNETIC FEED	THICK
GENERAL USE SYMBOLS CONNECTIONS TO SYMBOLS BRACKETS, LEADERS ETC. SIGNAL & POWER CONTROL REPEATED PATTERN ENCLOSURES	THIN
CONNECTIONS BETWEEN BRACKETS, JUMPERS	THIN
MECH CONN, SHLD, THRU INTER. APPEARANCES	THIN
BOUNDARY OF MECHANICAL GROUPING	THIN
ENCLOSURE OF EXTERNAL CKT. INFO.	THIN

32. **CIRCUIT PACK SYMBOLS**

THE SYMBOLS USED TO REPRESENT A CIRCUIT PACK IN AN FS MAY CONSIST OF ANY COMBINATION OF DISCRETE COMPONENTS, LOGIC SYMBOLS OR HIGH LEVEL RECTANGULAR SYMBOLS. THE INFORMATION ASSOCIATED WITH THE CP SYMBOL MAY CONSIST OF THE NAME OR TITLE OF THE CP, THE DESIGNATION, THE EQUIPMENT LOCATION AND THE CP CODE. THIS INFORMATION IDENTIFIES THE CP WITH RESPECT TO THE CIRCUIT AS A WHOLE. THE NUMBERS SHOWN ADJACENT TO THE CP SYMBOL ENCLOSURE IDENTIFY THE CP BACKPLANE ACCESS TERMINAL NUMBERS. FOR INFORMATION CONCERNING TABULAR SYMBOLS SEE BSP 005-111-101.

DESIGNATION (FUNCTIONAL)  
EQPT LOC  
CODE

SYMBOLS

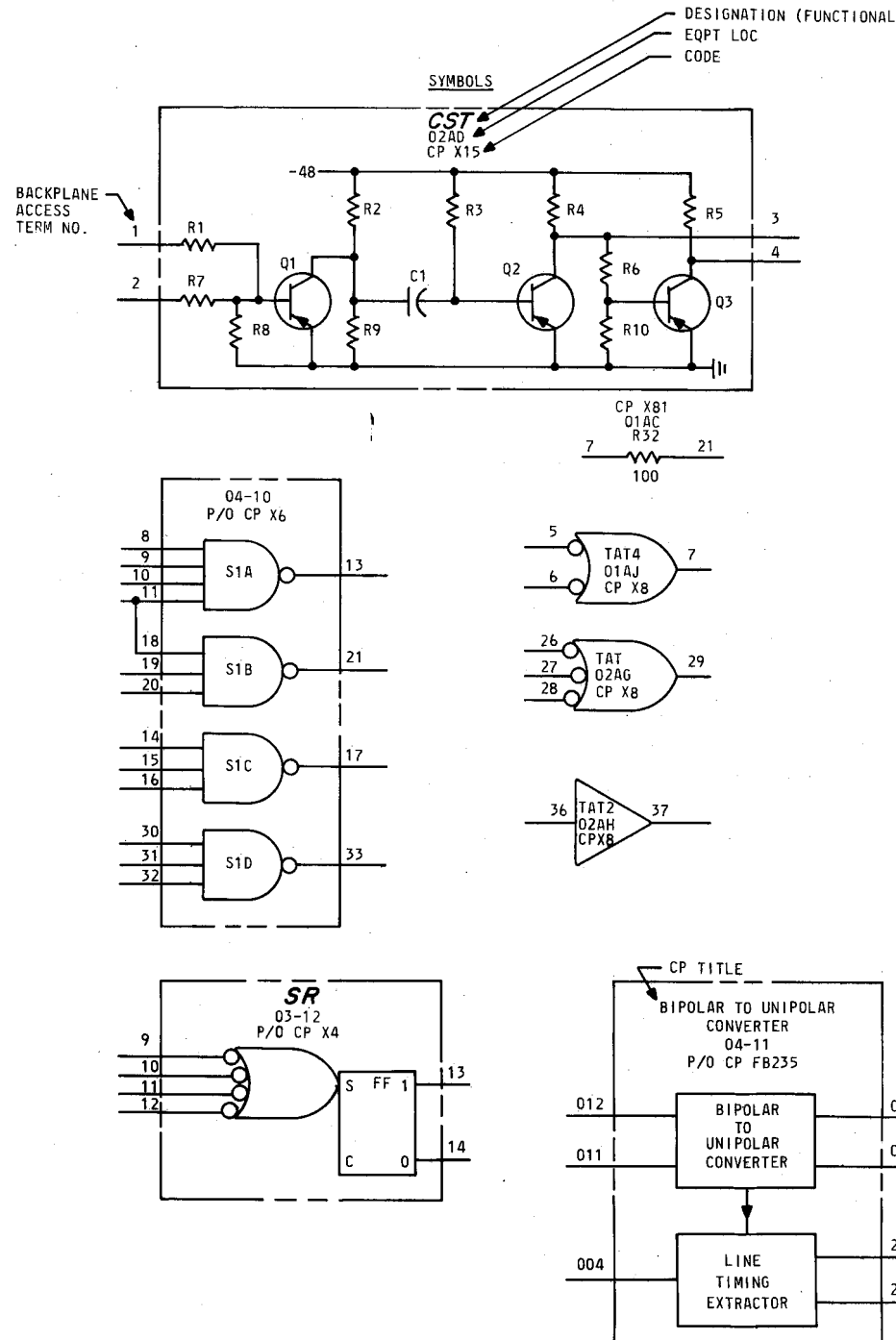

BACKPLANE ACCESS TERM NO.

CP X81  
01AC  
R32

CP X6  
P/O CP X6

CP X8  
TAT4  
01AJ  
CP X8

CP X8  
TAT2  
02AH  
CP X8

CP FB235  
P/O CP FB235

Fig 4—Methods of Showing Information on a Functional Schematic (Contd)

OPTIONS

51. ALL OPTIONAL WIRING AND OPTIONAL APPARATUS IS SHOWN IN THE FS.
52. ALL OPTIONAL INFORMATION IS ASSIGNED AN "OPTION DESIGNATION" CONSISTING OF EITHER LETTERS OR NUMBERS. THIS DESIGNATION IS SHOWN WITHIN A CIRCLE OR AN OVAL. TWO CONCENTRIC CIRCLES OR OVALS ARE USED TO ENCLOSE LETTERED CIRCUIT FIGURES OF ATTACHED-CONTACT TYPE SCHEMATICS WHEN CONVERTING TO DETACHED-CONTACT TYPE SCHEMATICS.
53. APPARATUS WHICH IS A PART OF, AND WIRING WHICH IS REQUIRED WITH, AN OPTIONAL APP FIG. IS DESIGNATED IN THE FS BY THE ENCIRCLED APP FIG. NUMBER, EXCEPT WHEN COVERED BY A LETTERED OPTION.
54. LETTERED OPTIONS ARE USED TO IDENTIFY OPTIONAL PORTIONS OF AN APP FIG. AND/OR OPTIONAL WIRING, IN ANY PART OF THE CIRCUIT.
55. WHEN THE APPARATUS AND WIRING OF AN ENTIRE FS IS OPTIONAL, THE OPTION DESIGNATION IS PLACED TO THE LEFT OF THE FS NUMBER.
56. WHEN ONLY PARTS OF AN FS ARE OPTIONAL, THE OPTION DESIGNATIONS ARE PLACED SO AS TO CLEARLY LIMIT AND DEFINE THE SCOPE OF THE OPTION. TO HELP DO THIS, IN SOME CASES ARROWS ARE ATTACHED TO CIRCLES USED TO ENCOMPASS THE OPTION DESIGNATION.

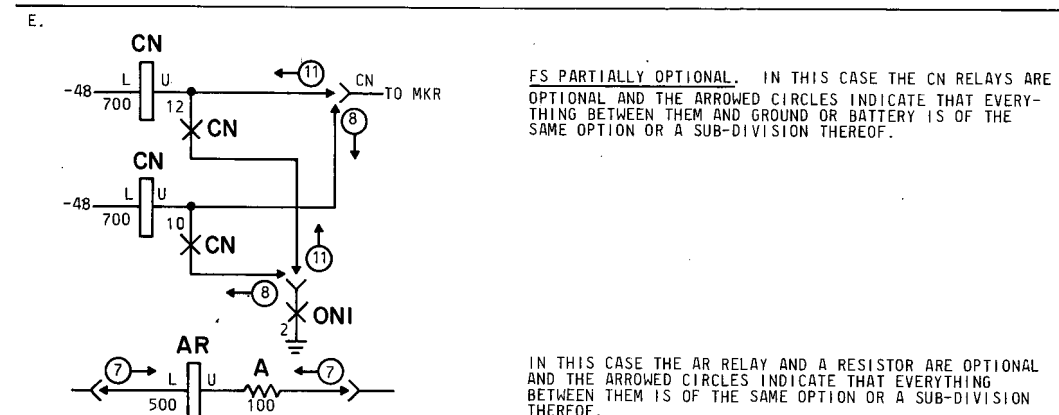
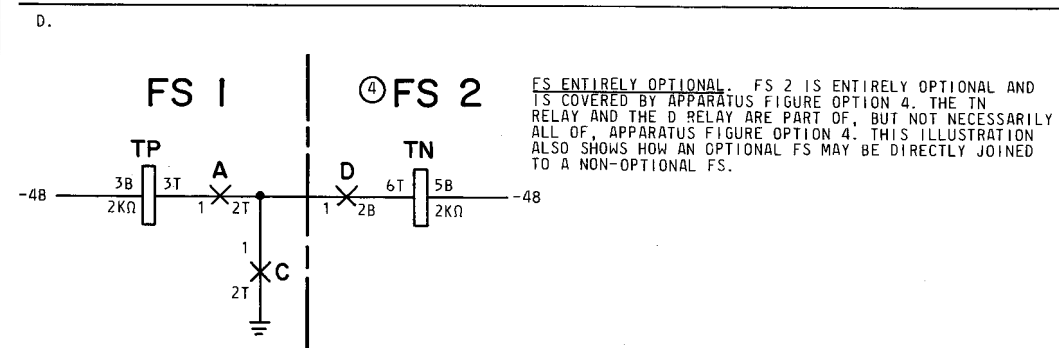
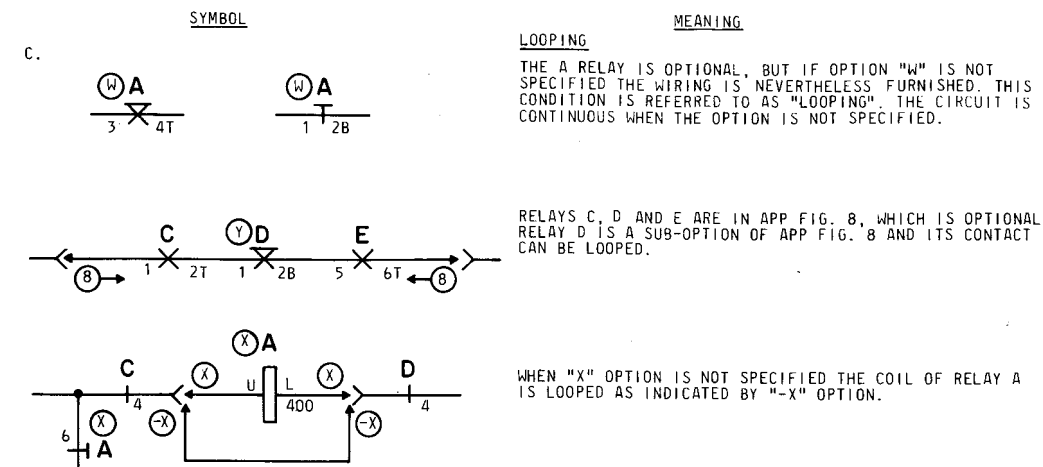
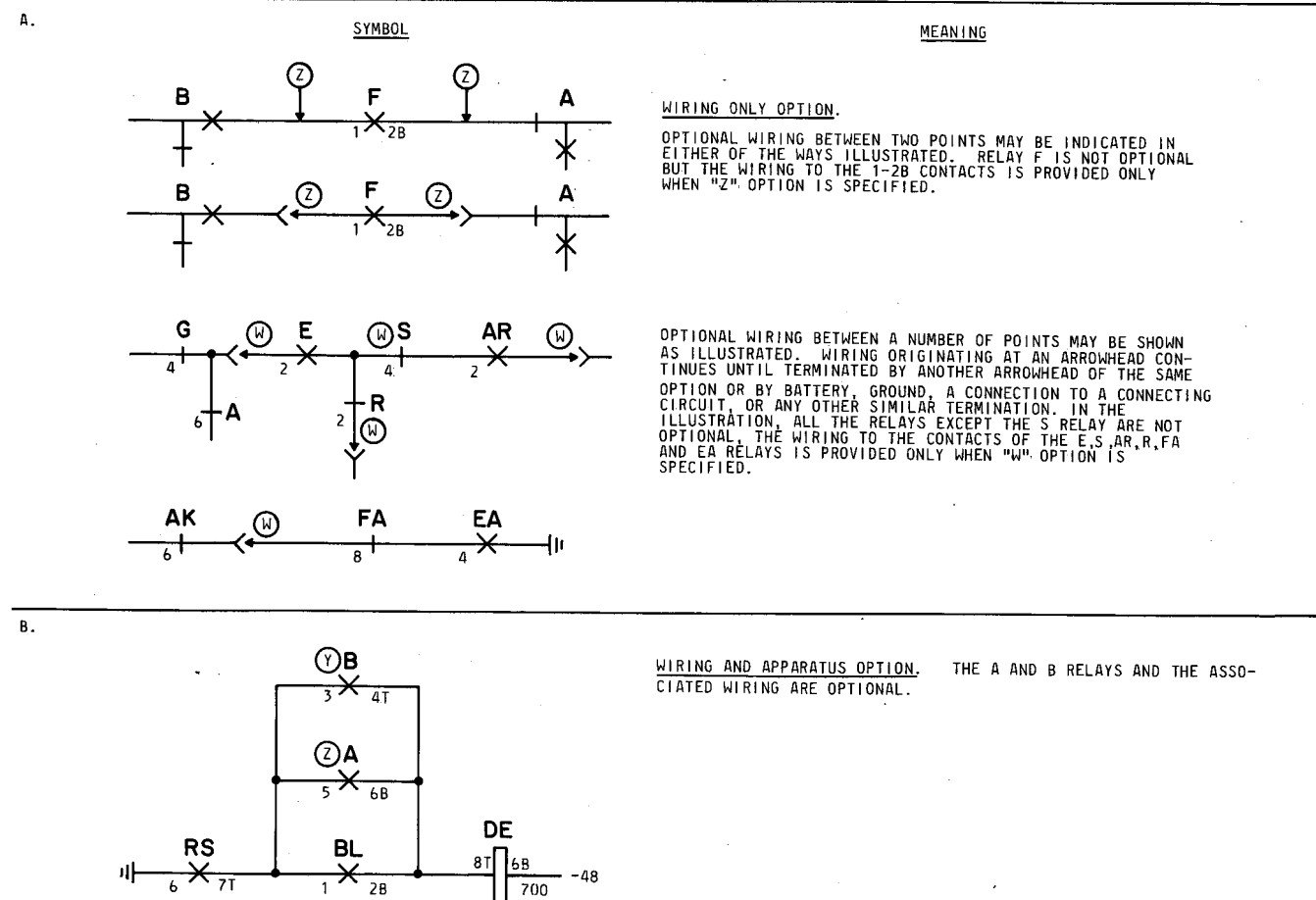

Fig 4—Methods of Showing Information on a Functional Schematic (Contd)

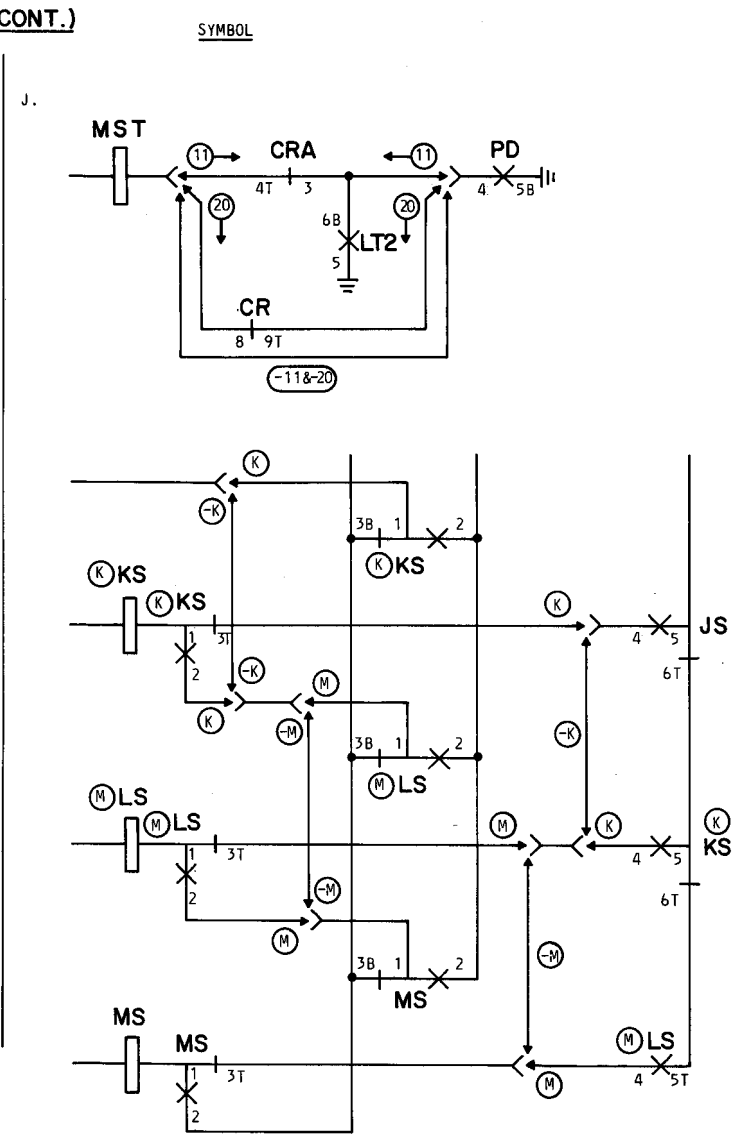
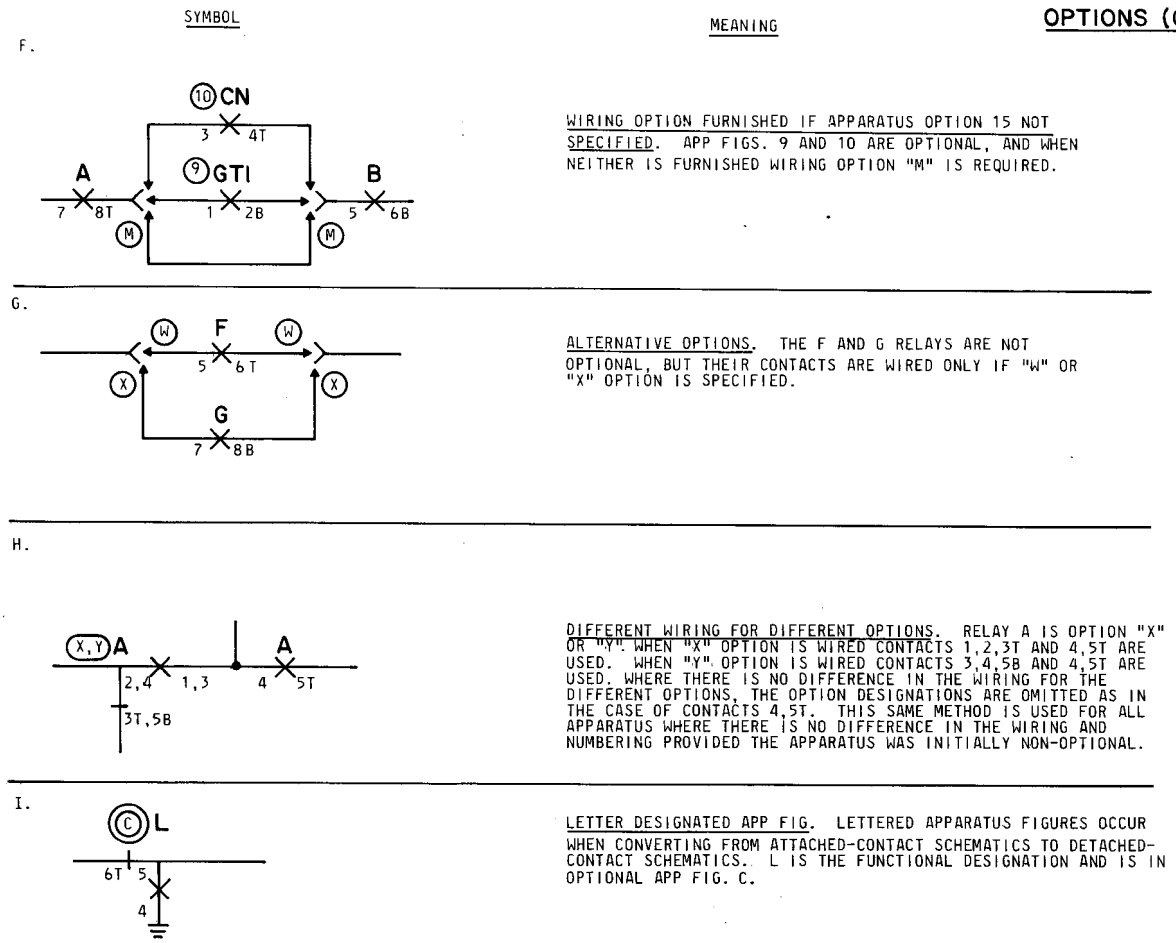

Fig 4—Methods of Showing Information on a Functional Schematic (Contd)



RELAY			
DESIG	RA	RB	
CODE	286A	286A	
OPTION			
54	2G5	3B4	
53	2G5	3B4	
52	2G5	3B5	
51	2G5	3B4	
50	2G5	3B6	
44	2G5	3A5	
43	2G5	3A5	
42	2G5	3A5	
41	2G5	3A5	
40	2G5	3A5	
34	3B1	3F1	
33	3B1	3F1	
32	3B1	3F1	
31	3B1	3F1	
30	3B1	3F1	
24	3G5	3F1	
23	3B8	3F1	
22		3F1	
21		3F1	
20		3F1	
14	3A8	3E1	
13	3C8	3E1	
12	3A1	3E1	
11		3E1	
10	2F5	3E2	
04	2F5	3E2	
03	2F5	3E2	
02	2F5	3E2	
01	2F5		
00	2F5		
COIL	2D5	3C3	

Fig 5E—Method of Showing Multicontact Wire Spring Relays

RELAY			
DESIG	CTEA	CTFA	FCRA
CODE	AJ7Q2	AJ7Q2	AJ7Q2
OPTION			
24	20F8		
23	19F7	20B1	
22	19F6	20B1	
21	19F6	20B0	
20	19F8	20B2	22B6
19	19F8	20B2	22B6
18	19F8	20B2	22B6
17	19F8	20B2	22B6
16	19F8	20B2	22B6
15	19F8	20B2	22B6
14	19F8	20B2	22B6
13	19F8	20B2	22B6
12	19F8	20B2	22B6
11	19F8	20B2	22B6
10	19F8	20B2	22B2
9	19F8	20B2	22B2
8	19F8	20B2	22B2
7	19F8	20B2	22B2
6	19F8	20B2	22B2
5	19F8	20B2	22B2
4	19F8	20B2	22B2
3	19F8	20B2	22B2
2	19F8	20B2	22B2
1	19F8	20B2	22B2
COIL	17F8	17H2	20D0

RELAY			
DESIG	D	H	
CODE	287A	288A	
OPTION			
59	4E4	6D2	
58	4E4	6D2	
57	4E4	6D2	
56	4E4	6D2	
55	4E4	6D2	
49	4E4	6D2	
48	4E4	6D2	
47	4E4	6D2	
46	4E4	6D2	
45	4E4	6D2	
39	4E3	6D1	
38	4E3	6D1	
37	4D3		
36	4D3		
35	5D4		
29	5D4	6B2	
28	5D4	6B2	
27	5D4	6B2	
26	5D4	6B2	
25	5D4	6B2	
19	5C3	5E5	
18	5B3	5E5	
17	5B3	5E5	
16		5F6	
15	4D5	5F6	
09	4D5	5F6	
08	4D5	5F6	
07		5F6	
06			
05			
COIL	4B5	5D3	
54	5F7	5G2	
53	5F7	5G2	
52	5F7	5G2	
51	5F7	5G2	
50	5E4	5G2	
44	5E4	5G2	
43	5E4	5G2	
42	5E4	5G2	
41	5E4	5G2	
40	5E4	5G2	
34	5E4		
33	5E4		
32	5E4	5F1	
31	5E4	5F1	
30	5E4	5F1	
24	4D2	5F1	
23	4D2	5F1	
22	4D2	5F1	
21		5F1	
20		5F1	
14		5E1	
13	4C8	5E1	
12	4C8	5E1	
11	4C8	5E1	
10	4C8	5E1	
04	4C8	5E1	
03	4C8	5E1	
02	4C8		
01	4C8		
00	4C8		
COIL	4C7	5E3	

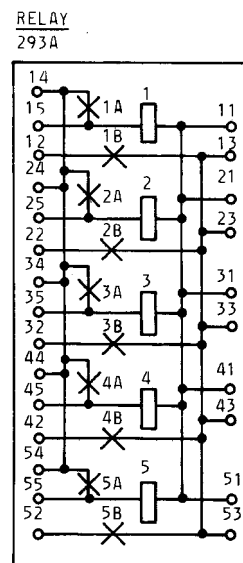

OPTION	DESIG	COIL	A. CONT	B. CONT
	[1]A0,1,2,4,7	3C1	3C1	6B3
	[1]B0,1,2,4,7	3D3	3D3	6C3
	[1]C0,1,2,4,7	3D4	3D4	6B8
	[1]CT0,1,2	3C3	3C3	3D3
ZE	[1]DVA,CG10,CN,CR,TN	3B4	3B4	3D4
	[1]D0,1,2,4,7	3B5	3B5	3D5

Fig 5F—Alternative Method of Showing Dry Reeds

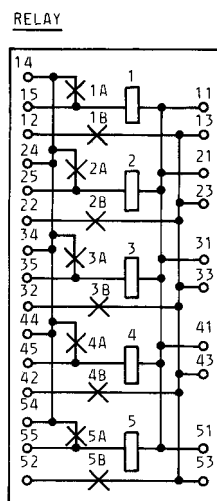

DESIG	BA	BB	BC	BD	BE	DR1D	DR2D	DR3D	DR4D	DR5D		
CODE	293A					293A						
OPTION	ZA											
COIL	POS	1	2	3	4	5	1	2	3	4	5	
	LOC	3C1	3C1	3C2	3C2	3C4	19G5	20A1	19G5	19G5	23B5	
CONT	A	LOC	3C1	3C1	3C2	3C2	3C4	19G5	17B3	18D5	19G5	23C5
	B	LOC	6B3	6B4	6B4	6B5	6B6	25E3	25E3	22A8	25E3	25E3

Fig 5G—Alternative Method of Showing Dry Reeds

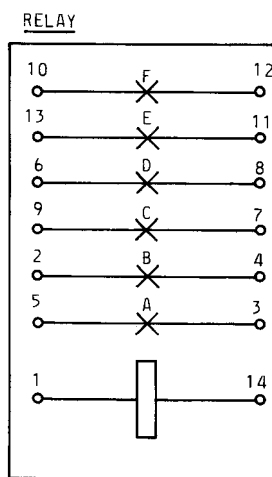

DESIG	DM1	DM2	FRO1	FRO2	FRO3	
CODE	295A	295A	295A	295A	295A	
OPTION						
CONT	F					
	E	31E8	38E8	31E9	31E9	31E4
	D	31E7	31E7	31E8	31E8	31E3
	C	31E6	31E6	31E7	31E7	31E2
	B	31E5	31E5	31E6	31E6	31E1
A	31E2	31E3	31E4	31E5	31E6	
COIL	31B2	31B1	31B3	31B3	31B5	

Fig 5H—Alternative Method of Showing Dry Reeds

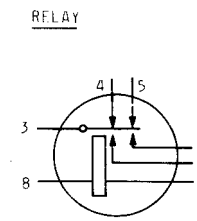

DESIG	10CLK	20CLK	CDL	CMIL	CM2L	CNDL	HM	JM	K2		DESIG
CODE	275A	276J	275A	275A	275A	275A	275A	275A	275A		CODE
OPTION											OPTION
8	52B6	52E6	53F2	53G1	53G1	53G3	79B2	79E2	81F3		8
7	52B6	52E6	53F2	53G1	53G1	53G3	79B2	79E2	81F3		7
6											6
5	52B6	52E6	53F2	53G1	53G1	53G3	79B2	79D2	81F3		5
4								79D2			4
3											3
2	52B7	52D7	53G2	53G0	53G1	53G3	79D2	80E2	81G3		2
1	52B7	52D7	53G2	53G0	53G1	53G3	79D2	80E3	81G3		1

Fig 5I—Method of Showing Mercury Contact Relays

RELAYS											
DESIG	CH			LR			TRL				
CODE	U1414			U1426			U574				
OPTION											
CONT	NO.	CONT	LOC	CONT	CONT	LOC	CONT	CONT	LOC		
	ARR	ARR		ARR	ARR		ARR	ARR			
TOP	12,11,10	BM	2F8								
	9,8	B	2D7	10,9	M	5C6	9,8	B			
	7,6	B	2D6	8,7,6	BM	6F4	7,6	M			
	5,4	B	2E5	5,4,3	BM	2E4	5,4	B			
	2,1,3	MB	11F2	2,1	B	3E7	2,1,3	MB	4B7		
BOT	2,1,3	MB	4G7	2,1,3	MB		2,1,3	MB	4D8		
	5,4	M	4C8	5,4	M	4C9	6,5,4	BM	9E5		
	7,6	M	4B7	7,6	B		8,7	M			
	10,9,8	BM	4C6	9,8	M	4C6					
	12,11	M	10B2								
COIL			4A7			4A8			4A7		

Fig 5J—Method of Showing Flat-Spring Relays

Fig 5E Through 5J—Methods of Showing Information in Apparatus Figures

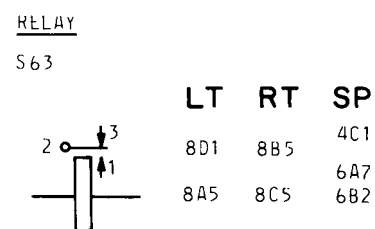

Fig 5K—General

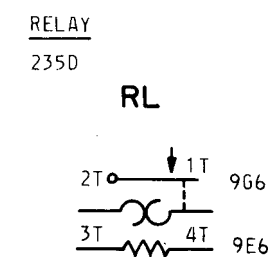
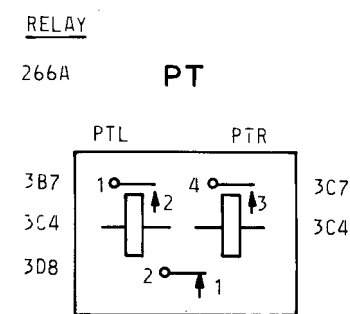
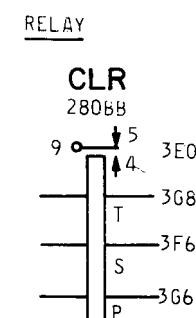
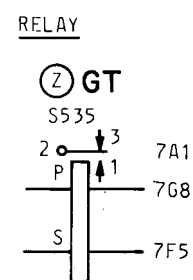
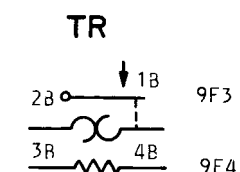
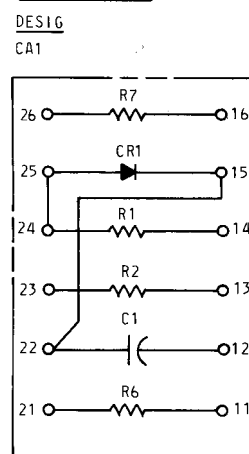

Fig 5L—Method of Showing Individual Relays



ASSEMBLY, COMPONENT  
TERMINAL STRIP



CODE	E/W
278A	

CAPACITOR

DESIG	LOC	CODE
C1	2C2	KS-16390

DIODE

DESIG	LOC	CODE
CR1	2B3	446C

RESISTOR

DESIG	LOC	CODE
R1	2B3	KS-19151
R2	2E2	KS-19151
R6	2C1	KS-19151
R7	2D1	KS-19151

CAPACITOR

OPT	DESIG	LOC	CODE
	A	3H3	440A
	B	3H3	KS-14330
[1]	R	4B5	437A
	T	4C3	
	S	6E9	KS-13368, L3, 0.001 UF
[2]	W1, 2	5C2	KS-13368, L3, 0.001 UF

CORD  
(SEE CONNECTOR)

OPT	DESIG	LOC	CODE
	CR1	2D6	417B
	CR2	4B7	HUGHES 1N97

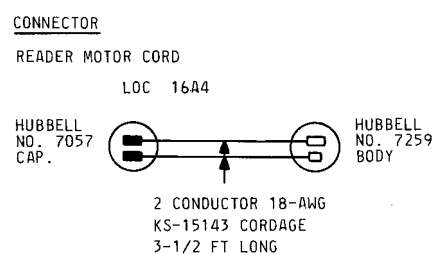

CONNECTOR

OPT	DESIG	LOC	CODE
	A	7F7	364 JACK
	B	7B2	364 JACK
	L14	8C1	141 JACK
	L15	3B5	141 JACK
	L17	5C8	141 JACK
	T	2F5	239 JACK
	-	7B8	2P4A PATCHING CORD
	-	7B6	2P4B PATCHING CORD
	WB1	3C2	151 PLUG

CONNECTOR  
280C JACK

OPT	DESIG	LOC	CODE
	L	18D7	18E7
	M	15B3	15B3
		18D7	18E7

Fig 5M—Method of Showing Capacitors

Fig 5K Through 5M—Methods of Showing Information in Apparatus Figures



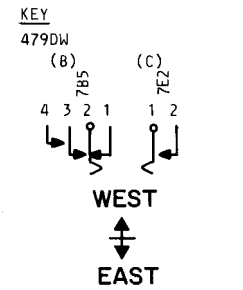
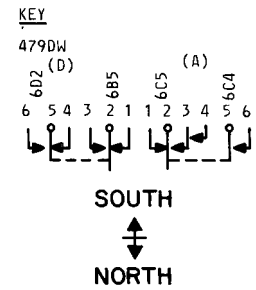
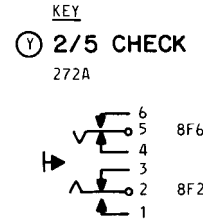
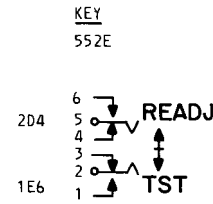
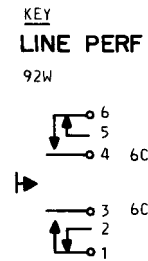

BELOW IS AN ILLUSTRATION OF HOW THE 479DW KEY APPEARS ON THE WECO CARD CATALOG WITH THE EXCEPTION THAT THE QUADRANT LETTERS A, B, C, AND D AND THE WORD "FRONT" ARE NOT SHOWN ON THE CARD CATALOG FIGURES. THIS ILLUSTRATION IS INCLUDED HERE ONLY AS AN AID IN INTERPRETING THE METHOD USED IN CONVERTING THE CARD CATALOG PICTURE TO THE APP FIG. SYMBOL AND IS NOT SHOWN IN THE APP FIGS. OF THE SD DRAWINGS.

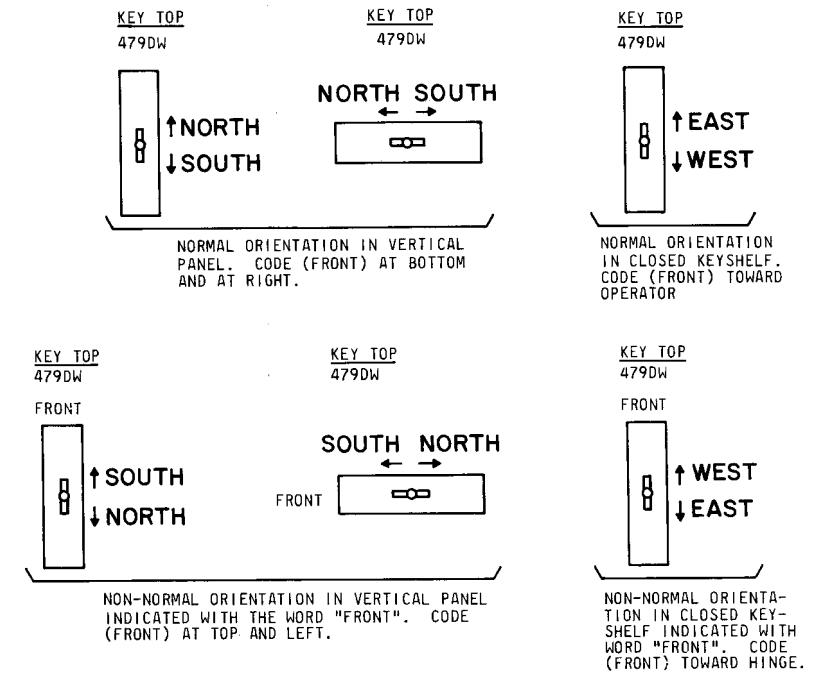
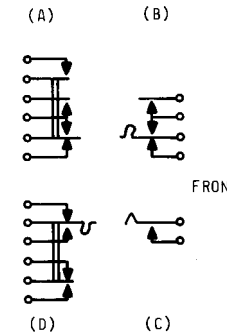
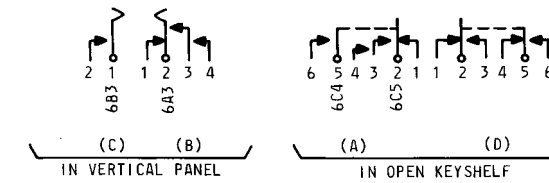

**LAMP**

OPT	DESIG	LOC	CODE
	ALARM	13A4	MAZDA 72
	CR	1A9	13L (RES)
	FA1	9C7	2Y
	FA2	9C8	2Y
	L1	7D3	2Y(RED)

**NETWORK**

OPT	DESIG	LOC	CODE
[3]	A0, 1, 2	3A7	185A
	BLC	6B9	180A
	G1A	5C6	185A
	G2A	5D6	185A
[3]	RA0, 1, 2	3B5	185A
[5]	RBO, 1, 2, 4, 7	3D4	185A
	RH	4B2	185A
	S	3G2	185A
[1]	TA-	6F3	185A
[1]	TA-	6F3	185A
[10]	TA0-9	7E2	177C
[10]	VO-9	4D4	185A
[1]	W	7D5	177C
	W	3B1	

**OUTLET & RECEPTACLE**

OPT	DESIG	LOC	CODE
	CAB	9C2	HUBBELL 52151-1/2 OUTLET BOX
			EW 2-9575 OUTLETS
	RECT	9B4	HUBBELL 7240 RECEPTACLE

Fig 5N—Method of Showing Keys and Keytops

**PLUG**  
(SEE CONNECTOR)

**POTENTIOMETER**

OPT	DESIG	LOC	CODE
	PPS ADJ	9H5	KS-5563,L3
	PPS CAL	9H6	G.R.CO.TYPE 301A
	VOLTS ADJ	9A5	KS-13790,L2, 1.5 MN

**RECTIFIER**

OPT	DESIG	LOC	CODE
	RECTIFIER	14C5	J86256B

**REGULATOR**

OPT	DESIG	LOC	CODE
	REGULATOR	14B5	KS-15631,L3

**RESISTOR**

OPT	DESIG	LOC	CODE
	A	2B3	18AG
	B	2B4	19GH
	C	2B6	145B,1000
	D	2B7	KS-13490,L1,1500
Y	[5] RO,1,2,4,7	3B9	18R
X	[2] TO,1	7C4	18AG

**SELECTOR**

DESIG	OPTION	CODE	BANK CODE	AHC												STEP MAG LOC	INT CONT LOC
				1		2		3		4		5		6			
				TERM.	LOC	TERM.	LOC	TERM.	LOC	TERM.	LOC	TERM.	LOC	TERM.	LOC		
A	Y	206A	26A	1-4 5,6 7-18 19 20-22	7D3 7D4 7C3 7C1 7D4	1-22	8A4	1-22	8D4	1-10 11 12-21 22	9B3 9C3	1-20 21 22	9F7	1-22	10A2	7B3	7B5

**SWITCH**

DESIG	J		T			
CODE	325B		325B			
OPTION						
LEVEL	WIRE	LOC	WIRE	LOC	WIRE	LOC
0-9	0	2A5	0	2B6		
0-9	1,2	3A2	1,2	3B3		
MAGNETS	HOLD	2B5	HOLD	2C4		
	SEL	2E9	SEL	2F7		

**SWITCH**

DESIG	COMB. LINE & JUNCTION SW		LINE SWITCH			
CODE	325D		325U			
OPTION						
LEVEL	WIRE	LOC	WIRE	LOC	WIRE	LOC
0-9	0	1D3	0	1D0		
0-9	1	1B3	1	1B1		
0-9	2	1A3	2	1A0		
MAGNETS	L HOLD	1D0	L HOLD	1D0		
	J HOLD	1D3	NT HOLD	1D3		
	LJ SEL	1E1	LO-9 SEL	1E1		
HOLD O.N. CONT	1T, 2T	1C1	1T, 2T	1C1		
	3T, 4T	1B1	3T, 4T	1B0		

**SWITCH**

DESIG	L OR SL			
CODE	328B			
OPTION				
LEVEL	WIRE	LOC	WIRE	LOC
0-9	0-5	6E2		
MAGNETS	HOLD	6C1		
	SEL	6B4		
SEL O.N. CONT	SO-9	6B4		
	SSD-9	6C4		

**SWITCH**  
324C

SEL MAG	LOCATION		HOLD MAG	HOLD O.N. CONT	
2 1 RB OR LT	COIL	SEL O.N. CONT	R L	3 5 4 2	05 03 01 01
9	3B0	3B1	LOCATION		
8	3B0	3B1	DESIG	IB	IG
7	3C0	3C1	COIL	3B9	3D9
6	3D0	3D1	CONTACT NO.	1,2	3C7
5	3E0	3E1		3E7	3D7
4	3E0	3E1		3E7	3F7
3	3F0	3F1	WIRE	5	3C9
2	3G0	3G1		3C7	3E7
1	3H0	3H1		3E7	3F7
0	3H0	3H1	0	4B7	4B4
			1	4B8	4B6
			2	4B7	4B5
			3	4B8	4B5

**SWITCH**

DESIG	FREQ					
CODE	KS-13546,L33					
OPTION						
SECT	1		2		3	
	TERM.	LOC	TERM.	LOC	TERM.	LOC
X	12-3	5A1	12-3	5D1	12-3	5E1
	4-8	8A1	4-8	8D1	4-8	9E1
	9-11	9B2	9-11	9C2	9-11	7C3

**SWITCH**

DESIG	J		T			
CODE	325B		325B			
OPTION						
LEVEL	WIRE	LOC	WIRE	LOC	WIRE	LOC
0-9	0	2A5	0	2B6		
0-9	1,2	3A5	1,2	3B3		
MAGNETS	HOLD	2B5	HOLD	2C4		
	SEL	2E5	SEL	2C7		

**SWITCH**

DESIG	S					
CODE	KS-13546,L40					
OPTION						
CIRCUIT	A		B		C	
	TERM.	LOC	TERM.	LOC	TERM.	LOC
SECT 1	12-3	8D2	4-7	8D3	8-11	7B3
SECT 2	12-3	6A3	4-7		8-11	8A4
SECT 3	12-3	7D5	4-7	8B2	8-11	

**SWITCH**

OPT	DESIG	LOC	CODE
	CLP	7D5	ESA-676800-42
	PLP	7E5	ESA-676800-42
	PLPO	7E1	ESA-676800-42
	PWR	9A1	HUBBELL 79D5
	RLP	7B5	TOGGLE SWITCH ESA-676800-42

**SWITCH**

**MB**  
KS-13535-01,L1

**SWITCH**

**AUD TEST**  
KS-13546,L33

SECT	LOC
1	7B8
2	7B7

**SWITCH**

**PULSE TEST**

DESIG	PULSE TEST					
CODE	KS-0000,L1					
OPTION						
CIRCUIT	A		B		C	
	TERM.	LOC	TERM.	LOC	TERM.	LOC
SECT 1	FRONT	12-3	2C4	4-7	3C5	8-11
	REAR	12-3	4D7	6-9	4C6	
SECT 1	FRONT	12-4	2F6	6-10	3G8	

**THERMISTOR**

OPT	DESIG	LOC	CODE
Y	A	9B4	8C
	B	9B5	8B

**TRANSFORMER**

OPT	DESIG	LOC	CODE
A		14G1	373F
B		2C5	94E REP COIL

**TRANSISTOR**

OPT	DESIG	LOC	CODE
A		6B4	2A
B		5B4	3A
C		5B4	3A
D		7D8	2A

**TUBE, ELECTRON**

OPT	DESIG	LOC	CODE
	CR1	7F4	313CC
	CR2	7G4	313CC
	TR	2C2	353A
	TR1	2D5	353A

**VARIATOR**

OPT	DESIG	LOC	CODE
	PK	3B8	400A
	V	2D4	33D

Fig 5P—Basic Tabular Form of Listing Information

DESIG	FUSE AMP	POTENTIAL	ONE PER
FA1	5	-24 FLT	BAY
FA2	5	-48 FLT	BAY
FA1		GRD	BAY
FA2		GRD	BAY
<u>BATTERY SYMBOL</u>		<u>VOLTAGE RANGE</u>	
	-24	-21.6 TO -26.4	
	-48	-43.2 TO -52.8	
dc CURRENT DRAINS IN AMPERES			
VOLTAGE	LIST 1		LIST 2
	-24	.012	.098
	-48	.018	.055

Fig 6—Fusing Note

RECORD OF APP FIGURES, WIRING AND APPARATUS CHANGES							
CHANGED ON ISS	IF JOB RECORDS DO NOT SPECIFY	THIS OPTION WAS FURN	SEE NOTE	USE IN CIRCUIT			
				STD	A&M	MD	
(1) 2D	M OR N	N		M		N	
(2) 3B	Y OR Z	Z		Y		Z	
(3) 3B	FIG. 6 OR 10	6		10		6	
(4) 4D	X	NONE	102	X			
(5) 4D	W	S OR T	107	W	T	S	
(6) 5B	FIG. 11 12 OR 13	NONE	107	11,12 OR 13			
(7) 6D				N		M	
(8) 7D						X	
(9) 7D	RESISTORS			441D		141D	
(10) 8B	A & B OR C	C		A & B		C	
(11) 9D			109				R

- (1) M ADDED, N RATED MD.
- (2) Y ADDED, Z RATED MD.
- (3) FIG. 10 ADDED, 6 RATED MD.
- (4) OPTION X ADDED.
- (5) W ADDED, S RATED MD, T, A&M
- (6) FIG. 11, 12 OR 13 ADDED.
- (7) N RERATED TO STD, M TO MD.
- (8) X RERATED TO MD
- (9) 141 RATED MD AND REPLACED BY COMPLETELY INTERCHANGEABLE 441D.
- (10) C REPLACED BY A&B.
- (11) APPARATUS PRODUCT CONTROLLED BY THIS DRAWING AND DEFINED BY "R" OPTION IS RATED MDNO

Fig 8—Record of Changes Table

FEATURE OR OPTION		PROVIDE		
		APP FIG.	APP OR WRG	QUANTITY
BAY MTD OR PORTABLE	BASIC FM RECEIVER WITH FRONT ACCESS, NORMAL-THRU JACKS FOR IF INPUT AND BASEBAND OUTPUT	1	Z	1 PER RCVR
	DIRECT WIRE IF INPUT AND BASEBAND OUTPUT TO JACK FIELD ON TERMINAL BAY		Y	
BAY MTD OR PORTABLE	ALARM CIRCUIT	2		1 PER RCVR
	LEVEL MONITOR		X	
BAY MOUNTED	dc CONNECTION TO REGULATOR REQUIRED WHEN ALARM CIRCUIT IS NOT PROVIDED		W	
	dc SUPPLY LEADS REQUIRED WHEN ALARM CIRCUIT IS PROVIDED		V	
PORTABLE	dc SUPPLY LEADS REQUIRED WHEN ALARM CIRCUIT IS NOT PROVIDED		T	
	dc SUPPLY ONLY		3	
	dc & ac SUPPLY	4		

Fig 7—Feature or Option Table

NETWORK VALUES			
NO.	NETWORK CODE	RESISTANCE	CAPACITANCE
		IN OHMS	IN UF
1	177F	1000	0.5
2	178F	160	1.0
3	1/2 177C	470	0.5

Fig 9—Network Values Table

TRANSMISSION TEST REQUIREMENTS (1 KHz LOSS BETWEEN 600 OHM TERMINATIONS)					
			MAX ALLOWABLE CKT LOSS (dB)		
			TRANSFORMER	LOSS	
			O20C	0.5	
			O20D	0.8	
			O20CS	1.4	
O20DS	1.6				
ALLOWABLE INDIVIDUAL APPARATUS LOSSES (dB)					
APPARATUS	DESIG	CODE	MAX LOSS	MIN LOSS	REMARKS
CAPACITOR	A OR B	4UF	20.9	17.3	
TRANSFORMER	A	O20C	0.4	0.2	
TRANSFORMER	A	O20D	0.7	0.4	
TRANSFORMER	A	O20CS	1.1	0.5	
TRANSFORMER	A	O20DS	1.3	0.8	
* INDICATES APPARATUS FOR WHICH INDIV LOSSES ARE NOT REQD					

Fig 10—Transmission Test Requirements Table

	RELAY	
	MDF	L
MAX EXT CKT RES	1.3K	1.9K
MIN INS RES	30K	30K

Fig 11—Working Limits Table

**SEQUENCE CHART  
NOTES**

1. THE PURPOSE OF A SEQUENCE CHART IS PRINCIPALLY TO SERVE AS A GUIDE TO THE UNDERSTANDING OF THE CIRCUIT AS A WHOLE AND AS A KEY TO THE ORDER OF EVENTS IN THE OPERATION OF THE CIRCUIT. FOR THIS PURPOSE, A SEQUENCE CHART MAY NOT NECESSARILY DEPICT ALL OF THE INTERACTIONS TAKING PLACE IN THE CIRCUIT. THE SEQUENCE CHART SUPPLEMENTS, BUT DOES NOT REPLACE, THE WRITTEN CIRCUIT DESCRIPTION (CD) WHICH ALWAYS ACCOMPANIES A SWITCHING SYSTEMS SD DRAWING.
2. SEQUENCE CHARTS EMPLOY SYMBOLS TO SHOW THE OPERATION AND RELEASE OF THE RELAYS, SWITCHES, AND OTHER DEVICES AS THEY PERFORM THEIR VARIOUS FUNCTIONS IN THE CIRCUIT.
3. TIME PROGRESSES FROM TOP DOWN, AND NEVER IN AN UPWARD DIRECTION, NOR AROUND AN ACUTE ANGLE.
4. THE OPERATION AND RELEASE OF THE CIRCUIT COMPONENTS IS INDICATED BY SYMBOLS PLACED IN A VERTICAL LINE(S) WHICH SERVES TO TRACE THE COURSE OF THE CIRCUIT ACTION. A SINGLE LINE OF ACTION MAY BRANCH INTO TWO OR MORE DEPENDENT LINES OF ACTION, AND CONVERSELY, SEVERAL LINES OF ACTION MAY CONVERGE. THUS, CAUSES ARE LINKED WITH THEIR EFFECTS BY SYMBOLS PLACED TO PORTRAY IN A CONCISE MANNER THE PROGRESSION OF THE CIRCUIT ACTION.
5. EACH OPERATE AND RELEASE SYMBOL IS IDENTIFIED BY THE FUNCTIONAL DESIGNATION OF THE APPARATUS IT REPRESENTS. IF THE APPARATUS IS IN ANOTHER CIRCUIT, BUT IS INCLUDED IN THE SEQUENCE CHART TO AID UNDERSTANDING, AN ABBREVIATED TITLE OF THE OTHER CIRCUIT IS GIVEN IN PARENTHESES FOLLOWING THE FUNCTIONAL DESIGNATION, i.e., A (MKR), B (T), ETC.
6. COORDINATES ARE USED TO LOCATE THE POSITION OF THE SYMBOLS. NUMBERS STARTING WITH 1, EVENLY SPACED, ARE PLACED FROM TOP TO BOTTOM ON THE LEFT AND RIGHT-HAND EDGES OF THE SHEET. LETTERS ARE PLACED LEFT TO RIGHT AT THE TOP AND BOTTOM EDGES OF THE SHEET. THUS, COORDINATE G24 MEANS VERTICAL COLUMN G, HORIZONTAL LINE 24.
7. HORIZONTAL AND VERTICAL LINE COMBINATIONS ARE USED AS FOLLOWS:
 

	CONNECTION BETWEEN LINES
	NO CONNECTION BETWEEN LINES
8. CONTROLLED DIRECTION IS INDICATED BY LINE COMBINATIONS USED AS FOLLOWS:
 

	ACTION ON VERTICAL LINE AFFECTS ACTION TO LEFT BUT NOT TO RIGHT.
	NO CONNECTION BETWEEN ACTION ON LEFT AND RIGHT HORIZONTAL LINES. THE ACTION ON THE TOP VERTICAL LINE HAS NO CONNECTION WITH THE ACTION ON THE LEFT HORIZONTAL LINE.
9. MAJOR ASSUMPTIONS OR OPTIONS ON WHICH A SEQUENCE CHART IS BASED ARE STATED IN THE SC TITLE, OR AS A SHEET NOTE ON THE SAME SHEET.
10. NOTATIONS ARE USED IN CONJUNCTION WITH FUNCTIONAL DESIGNATIONS TO GIVE ESSENTIAL INFORMATION; THESE ARE EXPLAINED IN THE NEXT COLUMN UNDER THE HEADING "DESIGNATION".

**DESIGNATIONS**

<u>FOR RELAYS</u>	<u>EXPLANATION</u>
1. C-	ONE OR MORE OF C <sub>0</sub> TO C <sub>n</sub> OR CA TO C <sub>n</sub>
2. CO-9	ALL OF C <sub>0</sub> TO C <sub>9</sub> INCLUSIVE
3. CO-C <sub>n</sub>	ALL OF C <sub>0</sub> TO C <sub>n</sub> INCLUSIVE
4. CO(0-9)	ALL OF C <sub>00</sub> TO C <sub>09</sub> INCLUSIVE
5. C(0-9)A	ALL OF C <sub>0A</sub> TO C <sub>9A</sub> INCLUSIVE
6. FA-D	ALL OF FA TO FD INCLUSIVE
7. A,C	BOTH A AND C
8. HG $\frac{2}{5}$	A COMBINATION OF "2 OUT OF 5" OF HG
9. RF $\frac{1}{2-8}$	ANY ONE OF A SERIES RF2 TO RF8
10. L/R	EITHER L OR R
11. (TOP) MC	TOP HALF OF MC MULTICONTACT RELAY
12. (BOT) MC	BOTTOM HALF OF MC MULTICONTACT RELAY
13. MC	BOTH HALVES OF MC MULTICONTACT RELAY
<u>FOR OTHER APPARATUS</u>	<u>EXPLANATION</u>
14. A JACK	A JACK CONTACT
15. AR KEY	AR KEY CONTACT
16. AL LAMP	AL LAMP
17. T HOLD	T HOLD MAGNET
18. J SEL	J SELECT MAGNET
19. PAC MAG	PAC MAGNET
20. A2 PERF	A2 PERFORATOR MAGNET
21. RDR PIN	READER PIN
22. (PU) TC INT	TC INTERRUPTER, PU CONTACT
23. RC $\frac{SEL}{10-11}$	RC SELECTOR STEPS FROM POSITION 10 TO POSITION 11
24. AD XSTR	AD TRANSISTOR
25. CL PH XSTR	CL PHOTO TRANSISTOR
26. TWA TUBE	TWA TUBE
27. VAR VARISTOR	VAR VARISTOR

**SYMBOLS**

<u>SYMBOL</u>	<u>EXPLANATION</u>
1. *A	A RELAY OPERATES
2. *AL LAMP	AL LAMP LIGHTS
3. *TW TUBE	TW TUBE OUTPUT CURRENT INCREASES
4. +A	A RELAY RELEASES
5. +AL LAMP	AL LAMP EXTINGUISHES
6. +TW TUBE	TW TUBE OUTPUT CURRENT DECREASES
7. *A *B *C +D	SIMPLE SEQUENTIAL CAUSE AND EFFECT RELATION. RELAY A OPERATES AND CAUSES THE OPERATION OF RELAY B WHICH, IN TURN, CAUSES THE OPERATION OF RELAY C. RELAY C THEN RELEASES RELAY D.
8. *A *B *C +D	MULTIPLE EFFECTS FROM A SINGLE CAUSE. RELAY A OPERATES AND CAUSES THE OPERATION OF BOTH RELAYS B AND C AND THE RELEASE OF RELAY D.
9. *A *B *C	MULTIPLE CAUSES FOR A SINGLE EFFECT. BOTH RELAYS A AND B MUST OPERATE BEFORE RELAY C OPERATES.
10. *B *A *E *C *D	MULTIPLE CAUSES WITH MULTIPLE EFFECTS. BOTH RELAYS A AND B MUST OPERATE BEFORE EITHER OF RELAYS C AND D CAN OPERATE. THE ARROW IS USED TO INDICATE ONE WAY ACTION. IN THIS ILLUSTRATION E OPERATES FROM B ONLY.
11. *B *A *C	ALTERNATIVE CAUSES. EITHER OF RELAYS A AND B WILL CAUSE OPERATION OF RELAY C.
12. *Z	Z RELAY OR OTHER APPARATUS HAS EITHER OPERATED OR RELEASED.

Fig 12—Sequence Chart Method of Showing Information

**SYMBOLS (CONT.)**

	SYMBOL	EXPLANATION		
13.		<p><b>TIME DELAY</b></p> <p>THE SR RELAY IS SLOW TO RELEASE FOLLOWING THE OPERATION OF RELAY A.</p> <p>THE TMA TUBE OPERATES 2 SECONDS AFTER CW RELAY OPERATES.</p>	18.	<p><b>TROUBLE RECORD</b></p> <p>THE SPAN OF CIRCUIT OPERATION DURING WHICH A PARTICULAR TROUBLE MAY BE EXPECTED IF A TROUBLE RECORD IS TAKEN IS INDICATED BY TRIANGULAR MARKS AT THE BEGINNING AND END OF THE SPAN.</p> <p>A SOLID INVERTED TRIANGLE (<math>\nabla</math>) INDICATES THAT A PERFORATION IS MADE, A LAMP IS LIGHTED, OR A NOTATION IS MADE ON A TICKET IF A TROUBLE RECORD IS TAKEN AT OR AFTER THIS TIME.</p> <p>A SOLID UPRIGHT TRIANGLE (<math>\blacktriangle</math>) INDICATES THAT A PERFORATION IS NOT MADE, A LAMP IS NOT LIGHTED, OR A NOTATION IS NOT MADE ON A TICKET IF A TROUBLE RECORD IS TAKEN AT OR AFTER THIS TIME.</p>
14.		<p>DOTTED VERTICAL LINE MAY INDICATE ONE OF FOLLOWING:</p> <p>A) INDEFINITE TIME INTERVAL.</p> <p>B) INTERMEDIATE ACTION WHICH IS EITHER ASSUMED OR SHOWN ELSEWHERE. IN THE LATTER CASE, REFERENCE IS USUALLY MADE TO THE PLACE WHERE THE ACTION IS SHOWN.</p>		<p>THIS INDICATES THAT RK PERFORATION IS MADE OR RK LAMP IS LIGHTED IF A TROUBLE RECORD IS TAKEN WHILE THE RK RELAY IS OPERATED.</p> <p>THIS INDICATES THAT CHARACTER 1 IS PRINTED IN POSITION 6 ON A TROUBLE TICKET.</p>
15.		<p><b>ALTERNATIVE ACTION.</b> THE OPERATION OF THE BT1 RELAY CAUSES THE RELEASE OF EITHER THE BT OR PB RELAY DEPENDING UPON WHETHER THE TRUNK IDLE OR TRUNK BUSY CONDITION IS MET.</p>		<p>IN THIS CASE, ONLY THE TICKET POSITION NUMBERS, 3 TO 8, ARE GIVEN. THE CHARACTERS THAT ARE PRINTED IN THESE POSITIONS ARE NOT SHOWN SINCE ANY CHARACTER FROM 0 TO 9, A DASH, OR AN ASTERISK MAY BE PRINTED.</p>
16.		<p>TK RELAY HAS OPERATED ON LINE 4 AS THE RESULT OF THE OPERATION OF BOTH HG ON LINE 1 AND LCK ON LINE 3. NEITHER HG NOR LCK OPERATION ALONE IS SUFFICIENT TO OPERATE TK. THE DIAGONAL LINE MAY BE CONTINUOUS OR AS SHOWN. HG AND LCK AT THE ENDS OF THE DIAGONAL LINE REFER TO THE FUNCTIONAL DESIGNATION OF THE APPARATUS TO BE ASSOCIATED. WHERE THIS APPARATUS IS SHOWN IN DIFFERENT SCs, ON DIFFERENT SHEETS OF THE DRAWING, OR IN WIDELY SEPARATED AREAS ON THE SAME SHEET, THE COORDINATE LOCATION OF THE ENDS OF THE DIAGONAL LINE MAY BE ADDED TO THE FUNCTIONAL DESIGNATION.</p>		<p>THIS INDICATES THAT T1 PERFORATION IS MADE OR T1 LAMP IS LIGHTED IF A TROUBLE RECORD IS TAKEN WHILE THE PR2 RELAY IS OPERATED.</p>
17.		<p>TG RELAY RELEASES AND THEN REOPERATES ON CURRENT REVERSAL.</p>		<p>THIS INDICATES THAT AC PERFORATION IS MADE OR AC LAMP IS LIGHTED IF A TROUBLE RECORD IS TAKEN AFTER THE AC RELAY HAS OPERATED AND BEFORE THE RD RELAY HAS OPERATED.</p>
				<p>THIS INDICATES THAT ONE OF A NUMBER OF TROUBLE INDICATIONS ARE MADE TO INDICATE CIRCUIT OPERATION PROGRESS. IF THE CIRCUIT OPERATION HAS ADVANCED TO THE OPERATION OF THE CKG RELAY, CHARACTER 0 IS PRINTED IN TROUBLE TICKET POSITION 11. IF THE CIRCUIT OPERATION HAS ADVANCED TO THE OPERATION OF THE RK RELAY, CHARACTER 1 IS PRINTED IN POSITION 11. CHARACTER 2 IS PRINTED IN POSITION 11 IF THE TCK RELAY IS OPERATED. IT IS NOT NECESSARY TO SHOW UPRIGHT TRIANGLES (<math>\blacktriangle</math>) INDICATING THE END OF THE PRINTING OF A CHARACTER SINCE ONLY ONE CHARACTER AT A TIME CAN BE PRINTED IN A POSITION ON A TICKET.</p>

Fig 12—Sequence Chart Method of Showing Information (Contd)

SEQUENCE CHART INDEX

DESIG	LOCATION	
	OPR	RLS
DP ORG REG CKT		
1IA	4W9	3Z12
1IB	4X11	3Z12
1TC	4X19	3Z12
2P	6H12	6N33
A2/5	3F36 14D8	3Z12 6U33 7P35 10P15
AS	3G7 6H12 8F11 9F10	
B2/5	14D7	3Z12
BS	3E37 4A10 4Z36 14C9	
BT	6B9	6A23
C2/5	14D6	3Z12
C1	9R10 9R19 10D11 11G13 11G21 11N18 11N25 13P21 13P28	9R15 9U25 10D15 11G17 11G27 11N22 11K32 13P25
CLR	9E17	9D26
CM3	14T22	
CMA	14Q22	
CMB	14Q22	
CMC	14Q22	
CN	8B11	8C36
CN1	9B11 9V3 11B5	8N21 10H22 11C23 13P30
CNT	13H8 13S5	13E15 13P39
CNT1	9D11	9C24
CNT2	9E18	9D28
CNT3	13U9	13P4

DESIG	LOCATION	
	OPR	RLS
DP ORG REG CKT (CONT)		
CR	806 8V9	8H14 8V20
CR1	8Q10 8V16	8N15 8T21
CR1 TUBE	8Q9 8V15	8R11 8U17
TPT	6K20 6S14	6H22 6Q16
TPT TUBE	6K19 6S13	6H22 6Q16
VF2/5	3B4 4B22 6J9 7A8 8E7 9F7	
VG2/5	3B4 4B22 6J9 7A8 8E7 9F7	

DESIG	LOCATION	
	OPR	RLS
MARKER CKT		
2P	6G12 7F11	
CHE		3Y1 6S23 7N25 8D26
CN	8B9	
CS	4H20 6G10 7F9 8A10 9B8	
DCT1	3E11 4E29 6J15 7A14 8D14 9E14	
DIS1	3Y5 6S26 7N28 8D28 10S7	
DIS2	3Y5 6S26 7N28 8D29 10S7	
GTL1	4H20 6G10 7F9 8A10 9B8	
MAN	4H21	
RBT	6B5	
TR2	6C5	
TRL	6B7	
TRLA	6B8	
TSE1		3E1 6K5 7B5 8D3 9E3

DESIG	LOCATION	
	OPR	RLS
MARKER CONN CKT		
MA	3N35	3Z8
MB	3N36	3Z9
MC	3M35	3AA8
MD	3M36	3AA9
ME	3L35	3AB8
MS	3N34 6S17 7M21	3AA7 6D28 7M30 8B31
RA	3P32	3W8
RB	3P33	3W8
RC	3Q32	3W8
RD	3N33	3W8
RE	3M33	3W8
RS	3P29 6S7 7M21	3W7 6Q28 7M30 8B31
TM	3N29	

TRK LINK & CONN CKT		
FA2	3E3 4E21 6K7 7B7 8D5 9E5	3E13 4E31 6J17 7D16 8D16 9E16
LV2	3E4 4E22 6K9 7B8 8D8 9E7	3G14 4D32 6G18 7F17 8B17 9D17

INTERRUPTER CKT		
ST	6A10	6A24

GROUP BUSY CKT		
RB1	14AB5	
RB2	14AB6	14Z15
RB3-6	14AB7	14Z16
RT	14Z14	

DESIG	LOCATION	
	OPR	RLS
PRETRANSLATOR CKT		
GS	14W19	
HDK	14U21	
PRA	14U19	
PRS	14U18	
TM	14S18	

Fig 13—Sequence Chart Index of Operate and Release Location

CIRCUIT REQUIREMENTS																	
APPARATUS				MECH REQ			CIRCUIT PREPARATION			DIRECT CURRENT FLOW REQ				REMARKS			
DESIG	CODE	OPTION	FIG.	BSP/ WECO FIG.	CONT PRESS	ARM TRVL	BLOCK OR INSULATE	TEST CLIP DATA		TEST SET PREP	SEE TEST NOTE	TEST WDG	TEST FOR		AFTER SOAK MA.	TEST MA.	READJ MA.
								CONN BAT.	CONN GRD.								
RELAYS																	
1IA	AF43		18				(RA)U		U(1IA)	GRD			0		31	29.5	
1IB	AF57		18				(RA)U		U(1IB)	GRD			0		27	25.5	
1IC	1/2 AK8		18					2U(1IC)	1U(1IC)	B/G			0		9.2	8.7	MOUNTED WITH (AS)
2P	AF34		13				(PHL)U		U(2P)	GRD			0		27	25.5	
AO,1, 2,4,7	285A		3								1		0		25		
													H		5		
													R		1		
AS	1/2 AK8		18					2L(AS)	1L(AS)	B/G			0		17	16	MOUNTED WITH (1IC)
BO,1, 2,4,7	285A		3								1		0		25		
													H		5		
													R		1		
BT	AF90		6						U(BT)	GRD			0		65.5	62	
CO,1, 2,4,7	285A		3								1		0		25		
													H		5		
													R		1		
CI	AF62		11						U(CI)	GRD	2		0		7.1	6.7	
CLR	280BB		9				(CNT1)0	6(CNT1)	8(CNT1)	NGB	3	P/S	0	-12	0.6	0.3	
							2(CNT1)	6(CNT1)	8(CNT1)	NGB	3	P/S	NO	-12	0.0	0.2	
								6(CNT1)	PCH H16	NGB			S	0	1.4		
							(LT1)0	2(CN)	L(CNT)	NGB		P	0		1.6		
TUBES, ELECTRON																	
CR1			8,11														SEE BSP
CR2			8,11														SEE BSP
CI			7														SEE BSP
TP1			12														SEE BSP

TIMING REQUIREMENTS													
APPARATUS			CIRCUIT PREPARATION			TEST SET PREP			SEE TEST NOTE	TIME REQ		REMARKS	
DESIG	OPTION	FIG	BLOCK OR INSULATE	TEST CLIP DATA		SEND KEY	REC SW			MIN	MAX		
				CONN BK	CONN B		CONN W	START	STOP				
CR1		11	(ON 1)U	GRD	U(CR1)	U(CR2)	MK	48	GRD		470	750	
CR1		8		GRD	U(CR)	4(CR1)	MK	U.C.	GRD		500	780	
CR2		8	(CN)U	GRD	U(ON1)	4(CR1)	MK	GRD	U.C.		470	750	
CR2		11	(ON1)U	GRD	U(CR1)	4(CR2)	MK	48	U.C.		470	750	
CI		7									1		
DI		5	(RH1)U (MS1)NU	GRD	U(DL)	U(MS1)	MK	48	GRD		3000	4700	CONN U(DL) 1C U(ON1)
IM		4									2		
TP1		12		GRD	U(PIA)	10(2P)	MK	GRD	48		220	370	

TEST NOTES:

- TO MEASURE THE TIME OF THE (CI) TIMER, OPERATE RELAY (CNT). THE (CNT3) RELAY SHOULD OPERATE IN A MIN OF 10 SECS AND A MAX OF 15 SECS.
- TO MEASURE THE TIME OF THE (IM) TIMER, OPERATE RELAY (IMA) RELAY (TM) SHOULD OPERATE IN THE INTERVALS INDICATED BELOW.

(PD)	(OVL)	SEC	
		MIN	MAX
N.O.	N.O.	20	32
N.O.	0	10	16
0	0	4.6	7.2

Fig 15—Timing Requirement Table

Fig 14—Circuit Requirement Table

Fig 14 and 15





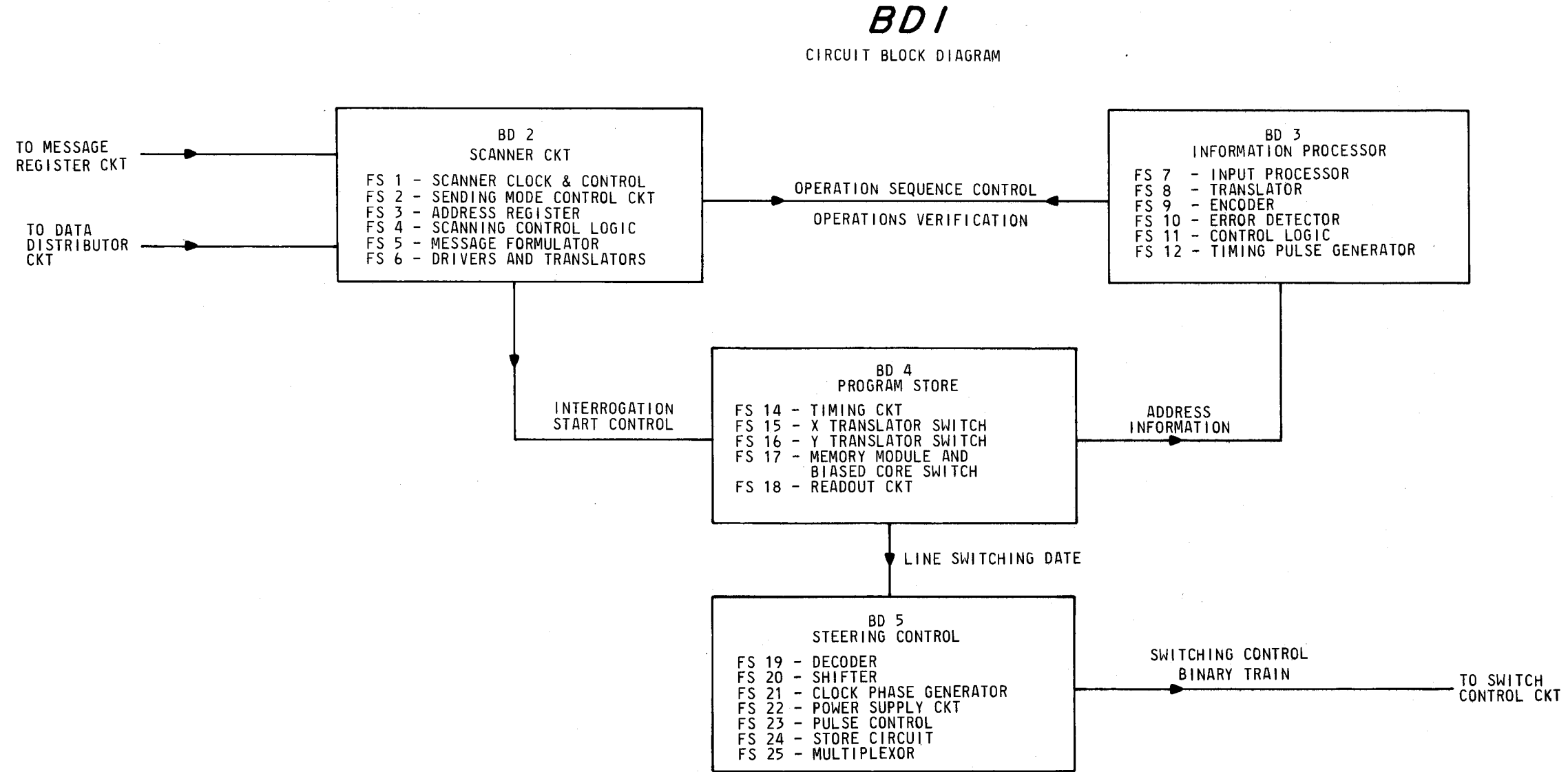

Fig 17A—Circuit Block Diagram

# BD 2

FS BLOCK DIAGRAM  
SCANNER CIRCUIT

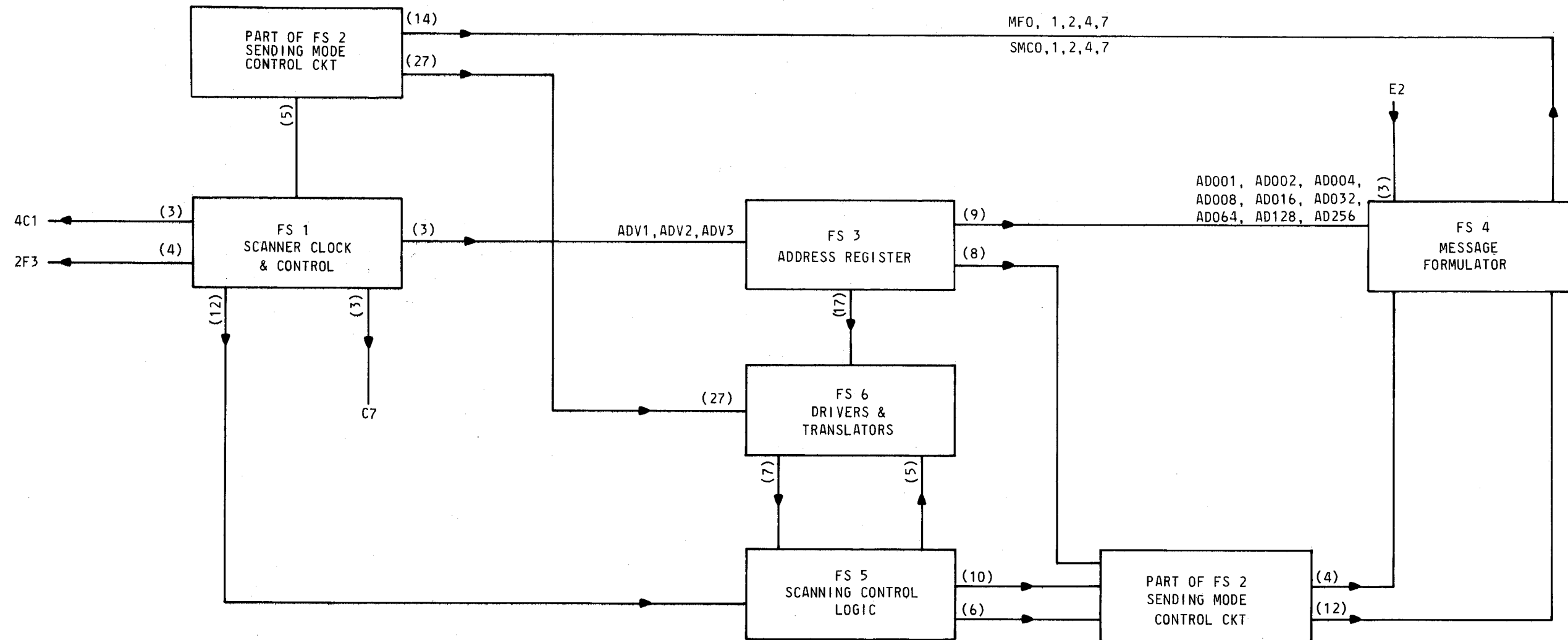

Fig 17B—Functional Schematic Block Diagram

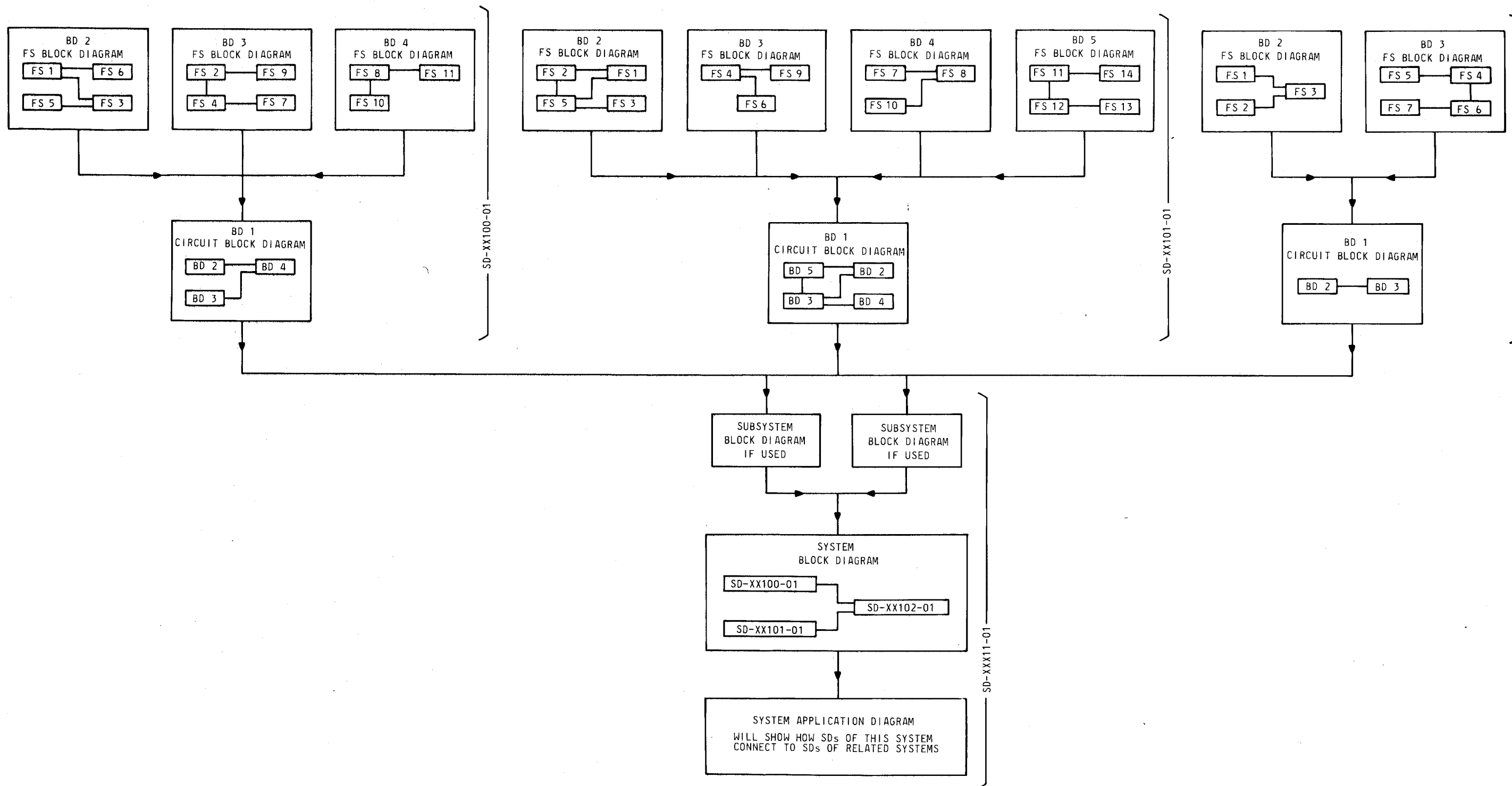

Fig 17C—System Block Diagram

**BD 4**  
SYSTEM APPLICATION DIAGRAM

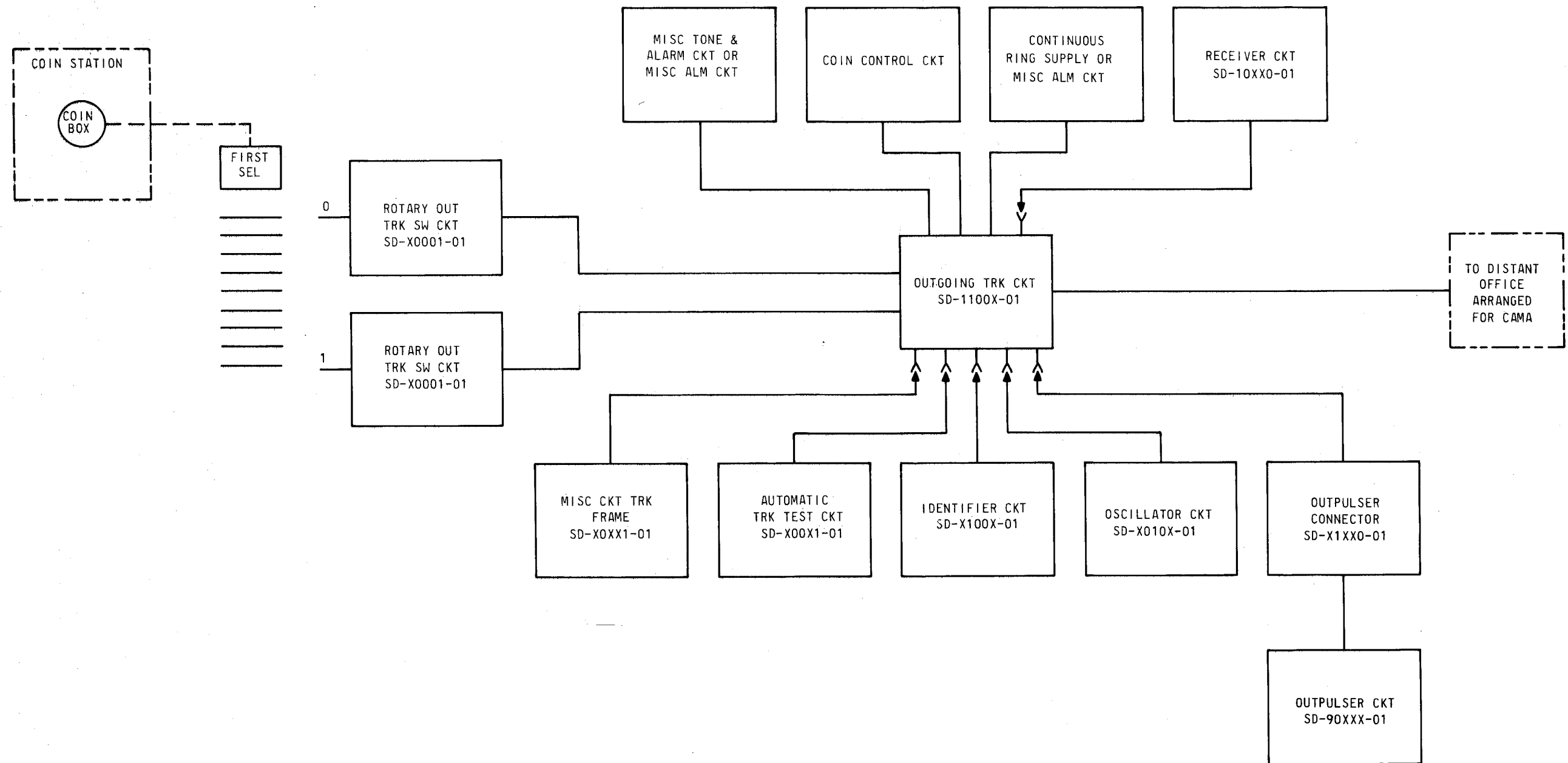

Fig 17D—System Application Diagram

**CPS 774**  
TWO AND FOUR WIRE TRANSFER AND TERMINATION

COMPONENT LIST

RELAY						
DESIG	K1		K2		K3	
CODE	MA6		MA6		MB10	
OPTION	CONT	LOC	CONT	LOC	CONT	LOC
ARR			ARR		ARR	
6					EBM	2B4
5					EBM	2F5
4	EBM	2D5	EBM	2C3	EBM	2C4
3	EBM	2D5	EBM	2B4	EBM	2B4
2	EBM		EBM	2A4	EBM	2A4
1	EBM	2F5	EBM	2A3	EBM	
COIL	2E3		2E3		2F4	

RELAY NOT ADJUSTABLE, REPLACE WHEN THERE IS A MALFUNCTION.

CAPACITOR

DESIG	CODE
C1	437QA
C2	570AS
C3	437QA
C4	437QA
C5	437QA

DIODE

DESIG	CODE
CR1	446A
CR2	446A
CR3	446A

RESISTOR

DESIG	CODE
R1	227A, 22.1
R2	227A, 261
R3	227A, 5110, 5110
R4	227A, 22.1
R5	227A, 261
R6	227A, 511
R7	KS-16891 L2A, 5420
R8	KS-16891 L2A, 5420
R9	KS-16891 L2A, 145
R10	KS-13491 L1, 750
R11	KS-13491 L1, 750
R12	82E, 700
R12	84H, 900

TRANSFORMER

DESIG	CODE
T1	HW1 1830

VARIATOR

DESIG	CODE
[16]RV1-RV16	100E

INPUT/OUTPUT INFORMATION

TRANSMIT AND RECEIVE SIGNALS APPEAR AT THE T AND R TERMINALS FOR 2-WIRE TRUNK LOSS AND NOISE MEASUREMENTS. WHEN 4-WIRE TRUNKS ARE TESTED, THE SIGNALS ARE RECEIVED ON T1 AND R1, AND TRANSMITTED ON T AND R. GROUND APPLIED TO CP PINS B19, A19 AND A7 WILL OPERATE THE K1 THRU K3 RELAYS RESPECTIVELY.

CIRCUIT DESCRIPTION

THE (K1) RELAY IS OPERATED DURING THE RECEIVE INTERVAL FOR THE 4-WIRE TESTS. THE (K3) RELAY TRANSFERS THE TERMINATING IMPEDANCE OF T AND R, AND T1 AND R1 FROM 600 OHMS TO 900 OHMS AT TRANSFORMER (1). THE (K1) RELAY INSERTS 2 DB OF LOSS IN THE MEASURING CIRCUIT WHEN OPERATED. THE 4.32 UF CAPACITORS DECOUPLE THE HIGH VOLTAGE PROTECTION CIRCUITS (RV1)-(RV16), FROM OFFICE BATTERY. (R1),(R4) PROVIDE TRUNK TERMINATIONS WHILE 4-WIRE MEASUREMENTS ARE PERFORMED. THE 1000 CPS TEST SIGNAL AT T AND R, AND T1 AND R1 MAY VARY FROM +5 DBM TO -15 DBM.

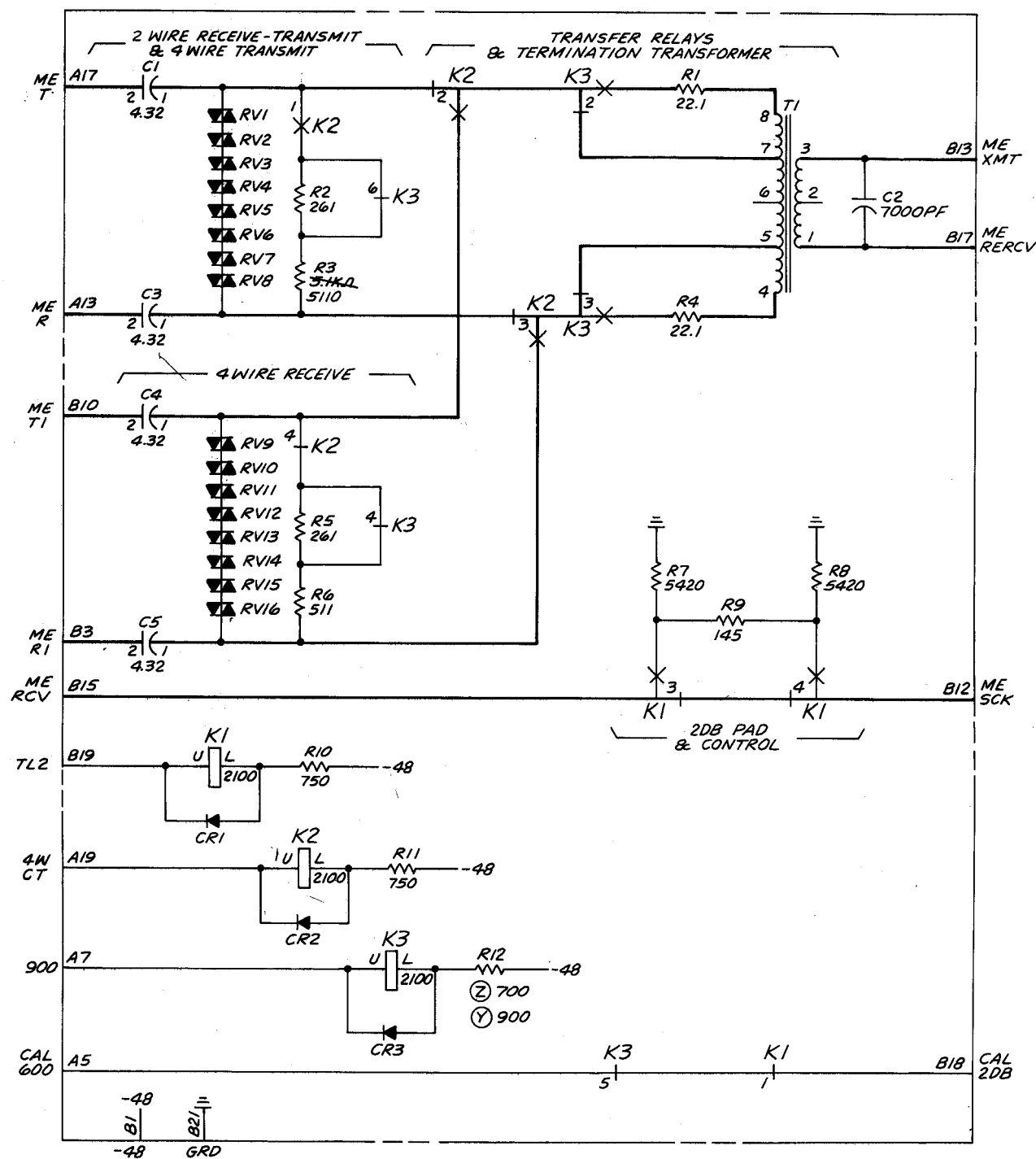

MANUFACTURING REFERENCES	
CATEGORY	NO.
CIRCUIT PACK CODE AND ASSEMBLY DRAWING	ED-77774-( )
CONNECTOR REQUIREMENTS: ON PWB - A,B	[2] 502A
ON FRAME - A,B	[2] 902A

SYMBOL

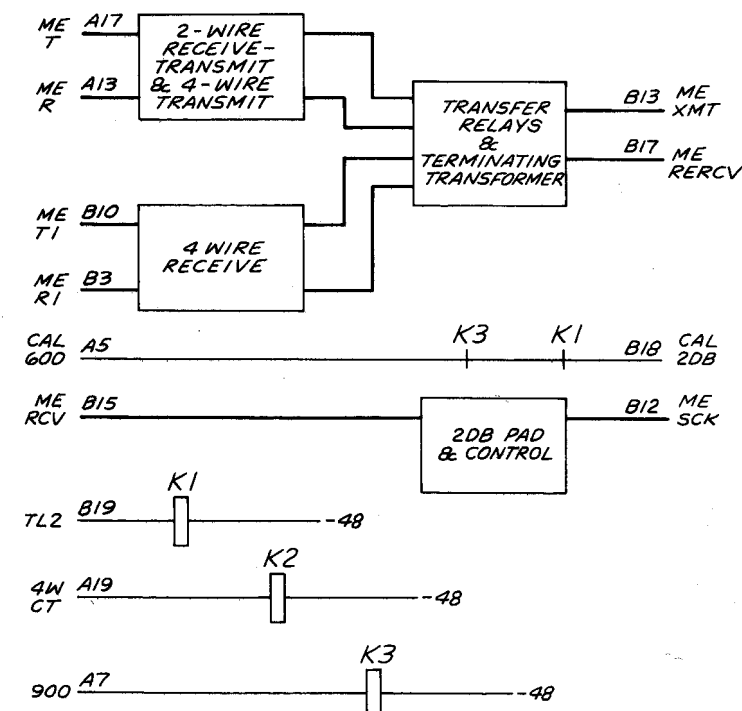

NOTES:

- UNLESS OTHERWISE SPECIFIED: RESISTANCE VALUES ARE IN OHMS, CAPACITANCE VALUES ARE IN MICROFARADS, VALUES PRECEDED BY THE SYMBOL +(PLUS) OR -(MINUS) ARE IN VOLTS.

RECORD OF CHANGES

DWG	PREV	STD	MFR	SERIES	CLEI	SEE
ISS	FURN		DISC	NO	CODE	NOTE
1				1	E1XXXXXXXX	
2B	Z	Y	Z	2	E1XXXXXXXX	
3A				4	E1XXXXXX	

Fig 18—Schematic Diagram Method of Showing Circuit Packs