

INSTRUCTIONS FOR INSTALLING THE 151988 OR 154651
MODIFICATION KIT ON LAC AND LAAC CABINETS TO
PROVIDE ELECTRICAL NOISE SUPPRESSION ON THE
POWER LINE AND SIGNAL LINE, RESPECTIVELY

1. GENERAL

a. The 151988 modification kit, when installed on LAC and LAAC cabinets, passes power line frequencies while attenuating radio interference frequencies; thus reducing undesired electrical noise.

(1) The suppressor of the 151988 kit operates at a nominal voltage of 120 volts ac and a maximum current of 7.5 amperes.

(2) Typical attenuations of the 151988 kit are:

<u>Frequency MC</u> <u>(10⁶ Cycles per Second)</u>	<u>Attenuation</u> <u>(Decibels)</u>
.10	15.5
.15	25.5
.6	65
1.0	85
2.4	82.5
2.8	83
10	75
12	75.5
15	75
20	75
25	80
50	70
100	68

b. The 154651 modification kit when installed on cabinets LAC and LAAC passes signal frequencies and dc while attenuating radio interference frequencies; thus reducing undesired electrical noise.

(1) The suppressor of the 154651 kit operates at a nominal voltage of 120 volts dc and a maximum current of 0.5 ampere.

(2) Typical attenuations of the 154651 kit are:

<u>Frequency MC</u> <u>(10⁶ Cycles Per Second)</u>	<u>Attenuation</u> <u>(Decibels)</u>
.10	16.5
.15	32
.6	73
1.0	84
2.4	83
2.8	82.5
10	76
12	76
15	72
20	75
25	79
50	69.5
100	72

c. The 151988 and 154651 kits consist of:

2	49514	Nut	1	151989	Suppressor, Electrical
2	92527	Lockwasher			Noise (only in kit 151988)
1	94660	Connector	1	154655	Suppressor, Electrical
2	125170	Screw			Noise (only in kit 154651)

d. For parts ordering information see Teletype Parts Bulletins 1149B and 1169B.

2. INSTALLATION

a. The 151988 modification kit (See Figures 1, 2, and 5)

(1) The electrical noise suppressor may be mounted on the upper shelf floor of a KSR or ASR cabinet.

(2) Remove the typing and keyboard mechanisms in accordance with standard procedure.

(3) Mount the suppressor on the upper shelf floor using the right opening in the center of the shelf.

(4) Remove the cover plate of the suppressor by removing its three retaining screws.

(5) Remove the star nut from the 94660 connector. Secure the connector to the underside of the shelf floor with the star nut.

(6) Insert the power line cable through the 94660 connector and connect the wires to the terminals in the suppressor.

(7) A ground wire must be connected to the grounding lug of the suppressor and it must be connected to a good ground for satisfactory operation of the suppressor.

(8) To relieve tension on the suppressor terminal connections, clamp the cable in place by means of the 94660 connector. If additional thickness is required, friction tape may be wound around the cable at the clamping point.

(9) For connecting the noise suppressor cable leads on any specific installation, refer to the applicable wiring diagram.

(10) Replace the noise suppressor cover plate.

(11) Replace the keyboard and printer mechanisms.

b. The 154651 modification kit (See Figures 3 and 4).

(1) The electrical noise suppressor may be mounted on the upper shelf floor of a KSR or ASR cabinet.

(2) Remove the typing and keyboard mechanisms in accordance with standard procedure.

(3) Mount the suppressor on the upper shelf floor using the left opening in the center of the shelf.

(4) Remove the cover plate of the suppressor by removing its three retaining screws.

(5) Remove the star nut from the 94660 connector. Secure the connector to the underside of the shelf floor with the star nut.

(6) Insert the signal line cable through the 94660 connector and connect the wires to the terminals in the suppressor.

(7) A ground wire must be connected to the grounding lug of the suppressor and it must be connected to a good ground for satisfactory operation of the suppressor.

(8) To relieve tension on the suppressor terminal connections, clamp the cable in place by means of the 94660 connector. If additional thickness is required, friction tape may be wound around the cable at the clamping point.

(9) For connecting the noise suppressor cable leads on any specific installation, refer to the applicable wiring diagram.

(10) Replace the noise suppressor cover plate.

(11) Replace the keyboard and printer mechanisms.

*

*

*

50372S

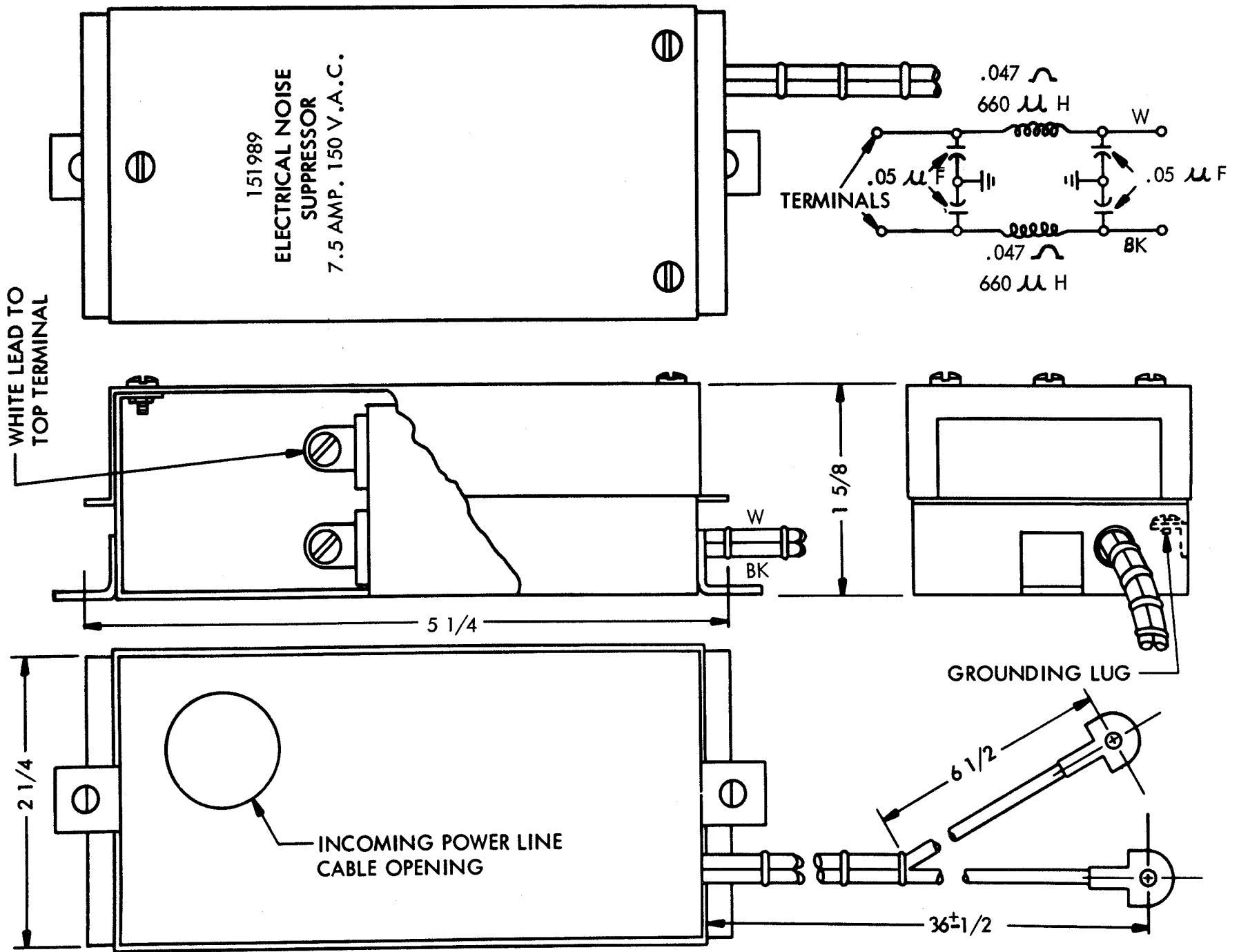
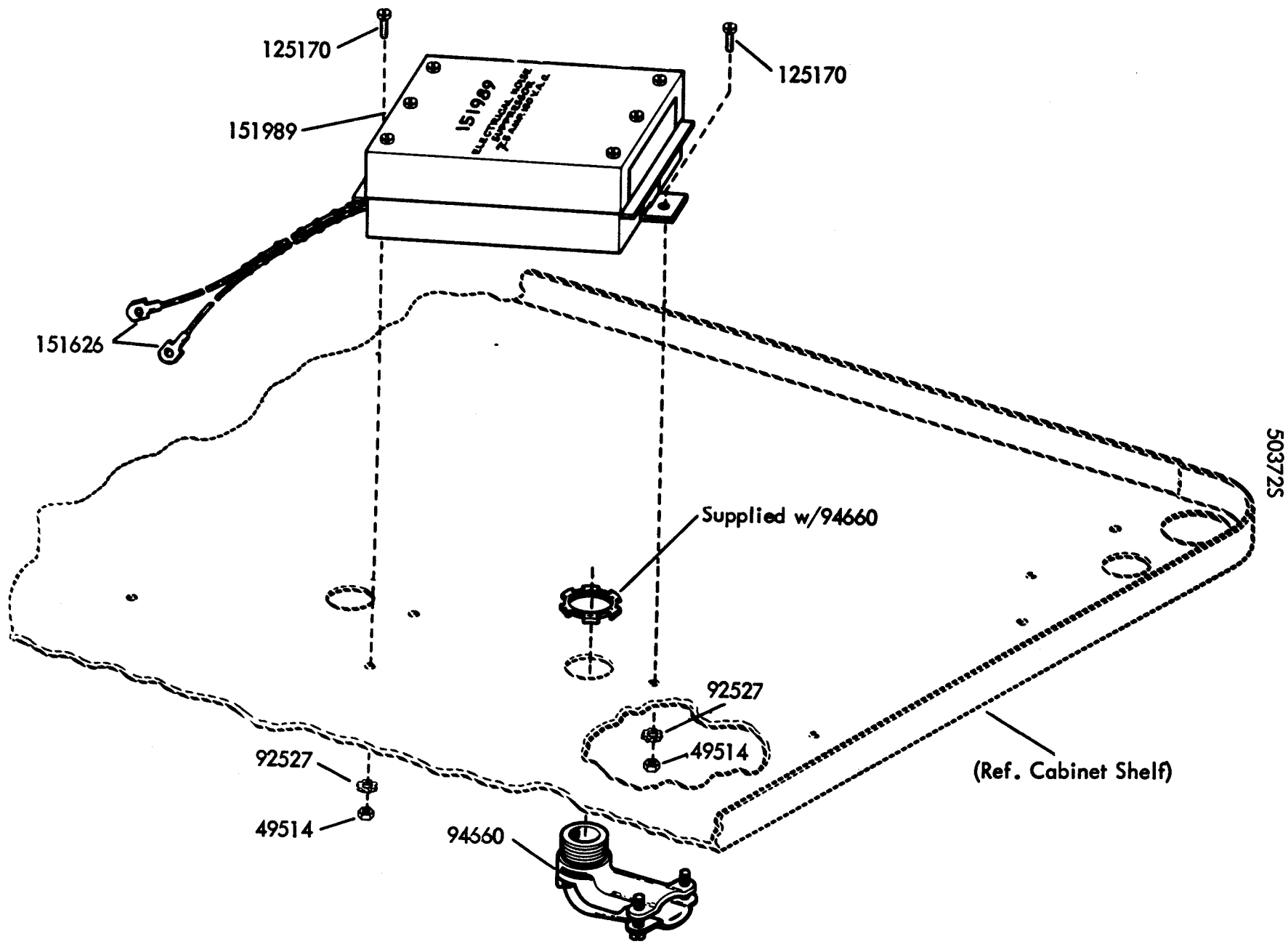

FIGURE 1

FIGURE 2



50372S

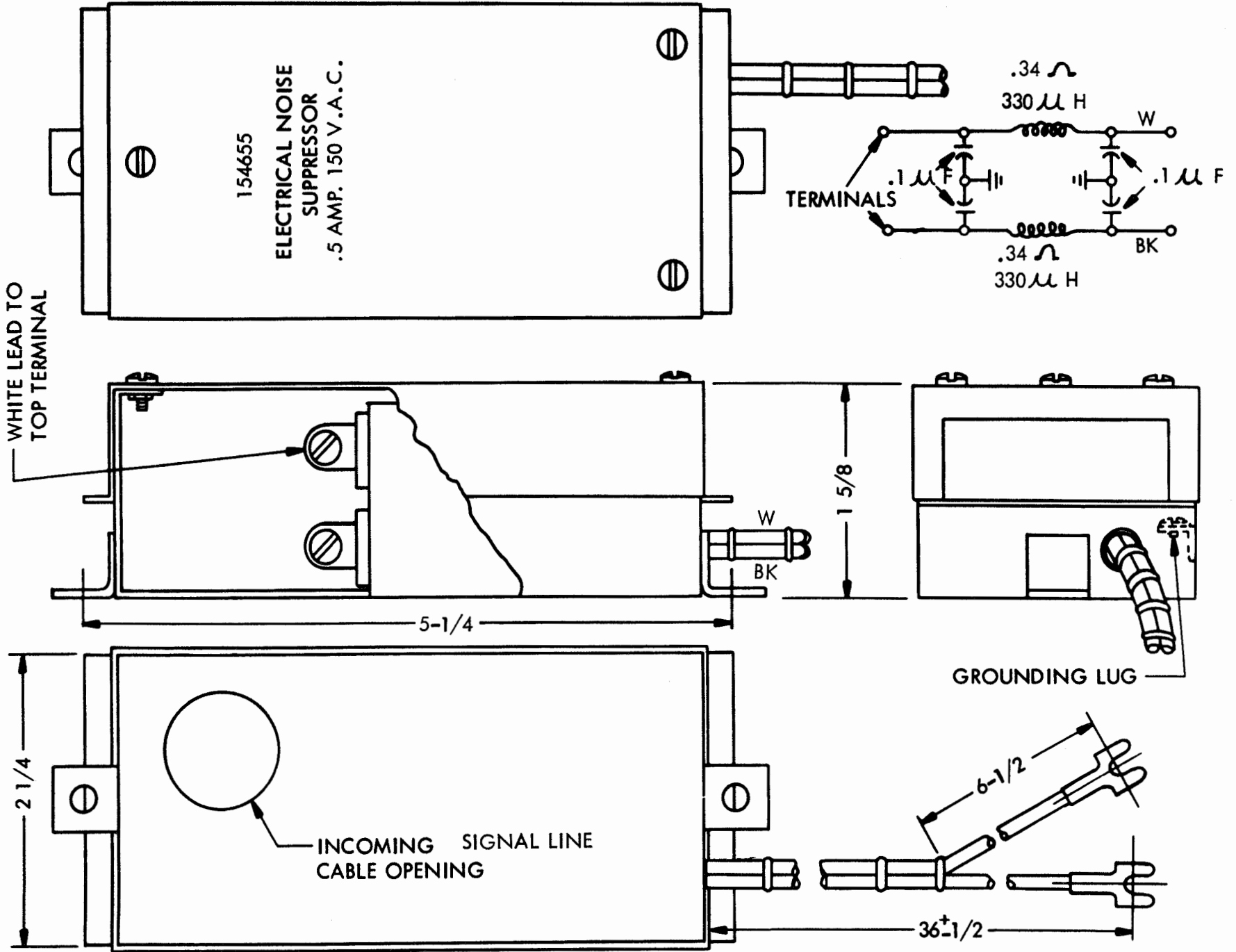

FIGURE 3

50372S

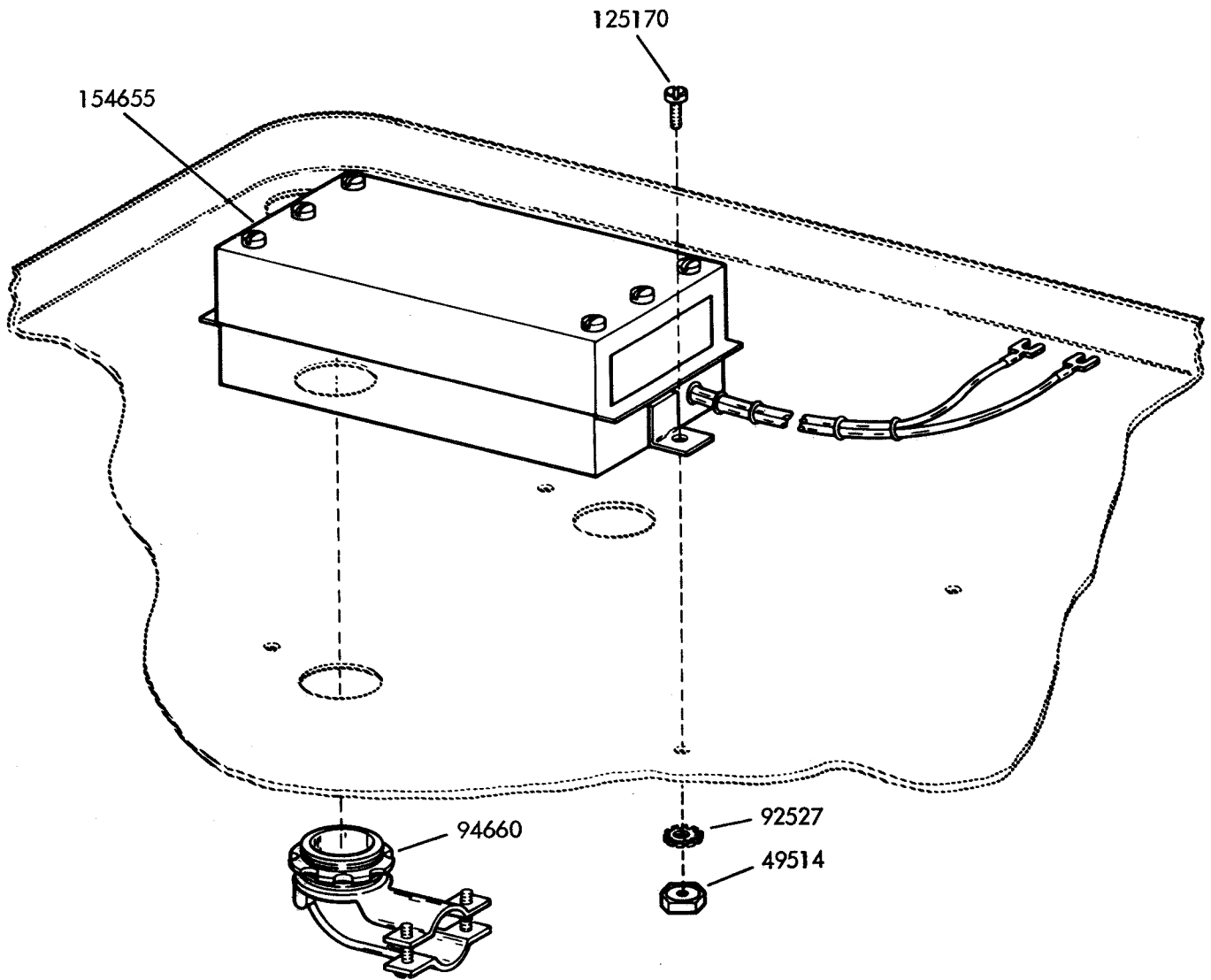
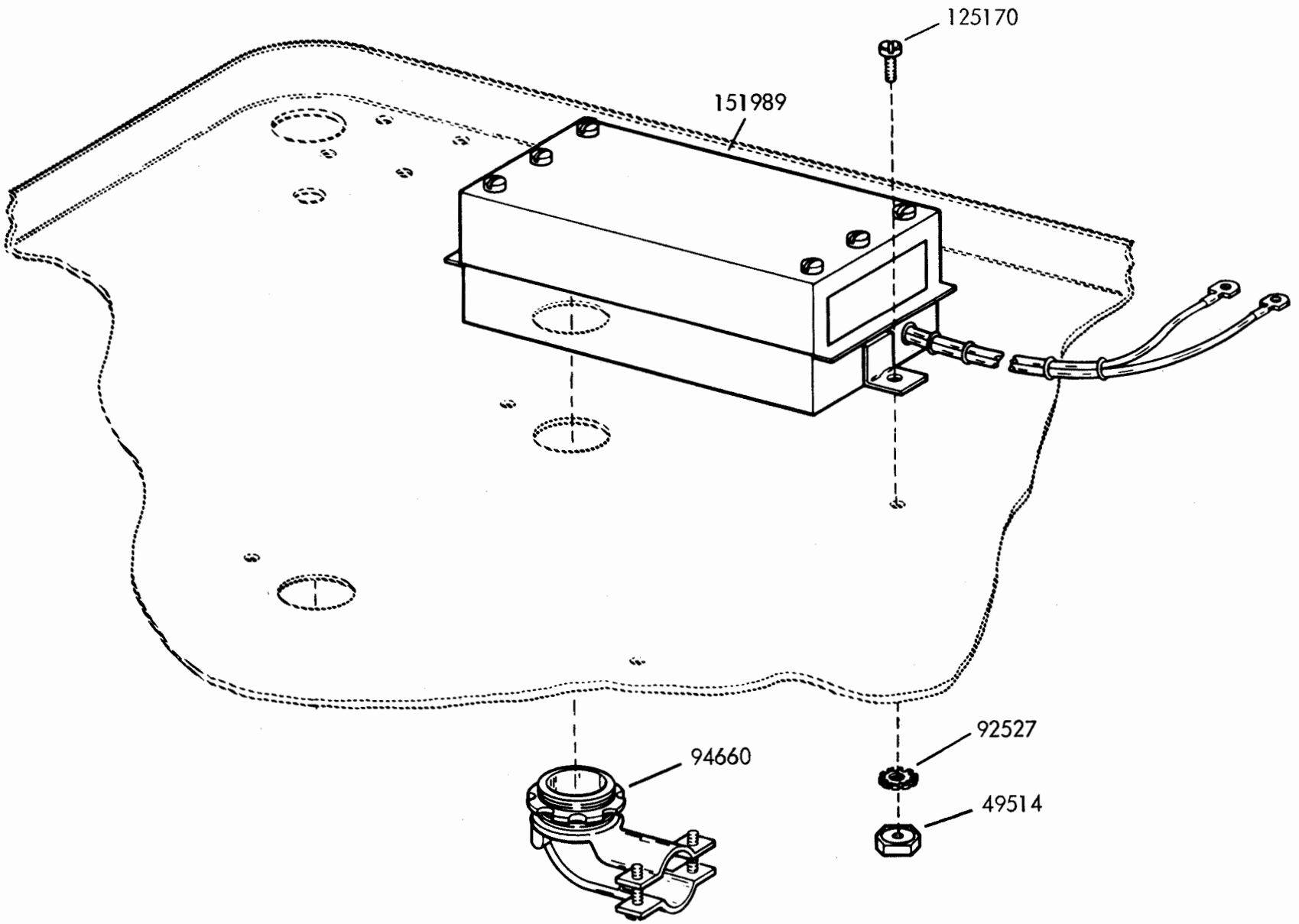

FIGURE 4

FIGURE 5



50372S