

CHANGES AND ADDITIONS  
TO BULLETINS 1108B (ISSUE 2) AND 1126B (ISSUE 1)  
PARTS - REPERFORATOR TRANSMITTER (MODEL 14)

This correction sheet supersedes correction sheets 659EE, 692EE, and 741EE.

BULLETIN 1108B, Page 1

Since a notch has been added to the 102399 Chad Box, a 120416 Detent Spring and three 120489 Spacers have been added to the 102396 Guide Strip on the right-hand side. Omit the 102764 Retaining Strip - Right.

To work over the 102399 Chad Box not equipped with a notch, Specification 5620S is supplied on orders for the 106991 set of parts which consists of one 120416 Detent Spring and three 120489 Spacers.

BULLETIN 1108B, Page 3

BULLETIN 1126B, Page 2

The 90438 Felt Button used in the rear bearing for the sensing and distributor shaft has been replaced by a 122547 Felt Button to provide improved lubrication. The 122547 Felt Button is approximately 9/16" long.

The 73018 Oil Cup has been replaced by a 117268 Oil Cup and a 76474 Nut.

The 120870 Lubricators have been added to the sensing and distributor cam sleeves. See Figure 1 for parts.

The 80471 Spring has been replaced by a 120599 Spring. The tension of the 102252 Spring has been increased; for identification purposes this spring is marked by a coat of green enamel and the 120599 Spring by a coat of gray enamel applied to one end turn of the springs. In order to keep both springs within the limits of the new requirements, a set of springs (102252 and 120599) should be ordered when a replacement of one is necessary.

BULLETIN 1108B, Page 4

BULLETIN 1126B, Page 3

In the front view of the distributor shaft bracket, the 4503 Clamping Plate has been replaced by 117266 Clamping Plate.

The 124134 Spring Bending Tool is recommended for adjusting the distributor contacts. See Figure 4.

The 103516 Oil Shield for the distributor contacts has been replaced by a 124187 Oil Shield. (Figure 5).

The 93758 Washers have been added to each of the 102458 Contact Levers (as indicated in illustration) to absorb excess oil. (Figure 5).

\*BULLETIN 1126B, Page 3

In the Subshaft (Assem.) drawing, the bearing housing shims are incorrectly labeled "110653 shims", and should be altered to read "111653 shims".

BULLETIN 1108B, Page 5

BULLETIN 1126B, Page 7

The 103399 Tape Chute has been replaced by a 120960 Tape Chute with embossed rib.

BULLETIN 1108B, Page 6

BULLETIN 1126B, Page 4

CLUTCH DETENT LEVER BRACKET AND TAPE-OUT CONTACT (ASSEM.) - The 115778 set of parts (Figure 6) replaces the following parts:

1047	Screw	102303	Roller
3598	Nut	102304	Lever, Detent
94665	Screw	125257	Spring
102028	Post, Spring		

BULLETIN 1108B, Page 6

CLUTCH MAGNET BRACKET - (ASSEM.) - A 120682 Clutch Magnet Release Spring has been added to the Clutch Magnet Bracket - (Assem). This release spring is assembled to the shaft of the clutch magnet assembly and rests against the upper end pieces of the magnet coils. Its purpose is to improve the armature release time and to prevent the armatures from sticking to their magnet cores because of oil residues.

BULLETIN 1108B, Page 7

BULLETIN 1126B, Page 17

The 110437 Spring associated with the 102415 Shift Latch in the upper illustrations and the 102262 Shift Lever in the lower illustrations has been replaced by an 84575 Spring.

In the upper illustration the 102416 Screw has been lengthened .064" (from .656" to .720") to accommodate the addition of a 3598 Nut.

BULLETIN 1108B, Page 10

BULLETIN 1126B, Page 9

The 98479 Guard for the type bar backstop as shown in Figure 2, now applies to all models.

BULLETIN 1108B, Page 11

In the contact assembly mounting parts, the four 6746 Screws have been replaced by 80342 Screws and four 72252 Washers have been added.

BULLETIN 1108B, Page 13

BULLETIN 1126B, Page 11

The 82440 Screw used for mounting the cams has been replaced by a 120896 Screw which is only partially threaded.

BULLETIN 1108B, Page 14

BULLETIN 1126B, Page 12

OIL SHIELD FOR SELECTOR MAGNET CORES - The 113693 Set of Parts (Figure 7) has been added to the holding magnet selector. New style 92273 Magnet Cores have a red spot on the rear surfaces for identification purposes.

\*Specification 5682S contains instructions for the installation of the 113693 set of parts.

BULLETIN 1108B, Page 15  
BULLETIN 1126B, Page 13

In the center illustration, the 1174 Screw (right side) has been replaced by a 94669 Screw and the 3640 Lock Washer and 3599 Nut have been omitted.

BULLETIN 1108B, Page 16  
BULLETIN 1126B, Page 14

The "100185 Spring Post" in the upper illustration of Bulletin 1108B and the "74554 Spring Post" of Bulletin 1126B have both been replaced by an "86506 Spring Post".

In the lower illustration, six 90752 Felt Washers have been added (for lubrication purposes) to the 101903 Stud between the arms of the 101904 Bail-Upper.

BULLETIN 1108B, Page 17  
BULLETIN 1126B, Page 15

The 72509 Lock Washer (Bulletin 1108B) and 2191 Lock Washer (Bulletin 1126B), associated with the 74399 Screw, 125015 Washer, and 95438 Nut, have been replaced by a 107116 Lock Washer.

A 2191 Lock Washer has been added to the 125163 Screw that secures the 101995 Detent Lever.

Four of the six 95417 Separators have been replaced by four separators of new design. See Figure 3 for parts. In the upper illustration, the 7603 Spring replaces the 115978 Spring in Bulletin 1108B and the 112634 Spring in Bulletin 1126B.

The 102379 ribbon guide has been replaced by a 123945 ribbon guide. The 123945 ribbon guide differs from the 102379 ribbon guide in that the end of the long projection is bent at an angle of approximately 30 degrees.

BULLETIN 1108B, Pages 17 and 18  
BULLETIN 1126B, Pages 15 and 16

In the upper illustrations the 101987 punch selector fingers have been replaced by 117257 punch selector fingers which are .047" longer and have a notch on the flared out portion mounting the retaining spring.

The 101988 Spring Bracket and 112634 Springs (5) have been replaced by the new style 101988 Spring Bracket and 42661 Springs (5). The right-hand side of the new style bracket which has three spring holes is now .250" in height. The 112634 Spring is erroneously listed as 115978 on Page 18 of Bulletin 1108B. The new style 101988 Spring Bracket and 42661 Springs (5) should be used with the 117257 Punch Selector Fingers.

BULLETIN 1108B, Page 19  
BULLETIN 1126B, Page 18

In the upper illustration (Bulletin 1108B) and lower illustration (Bulletin 1126B) the 112627 Nut on the 102220 Shaft (redesigned) has been replaced by two 119648 Retainers (one at each end); the 102228 Tape Operating Bail is replaced by the 120961 Tape Depressor Bail, modified for better guidance of the tape loops.

\*The 102204 springs associated with the 111060 code punch block assembly have been replaced by the 124661 springs.

BULLETIN 1108B, Page 20

BULLETIN 1126B, Page 19

In the lower illustrations, the 1047 Screw and 3598 Nut that secure the 102303 Roller have been replaced by an 82532 Screw and 3606 Nut respectively.

A 121922 Tape Deflector (yoke rod shield) has been added to the pivoted transmitter assembly. It pivots on the yoke rod and is held in place by two 121923 springs anchored to two 78872 brackets.

BULLETIN 1108B, Page 21

The 102441 Selector Yoke Plate has been redesigned; it is similar to the 105139 Plate used on FRXD9 and 10 (shown on page 20) with the exception that the 102441 Plate has a bevel added to the tape channel.

When a 102441 Selector Yoke Plate or 102448 Transmitter Lid is ordered, the new style 102441 Selector Yoke Plate and 105133 Transmitter Lid are furnished since the yoke plate and lids are not individually interchangeable.

BULLETIN 1108B, Page 22

The 115515 Transfer Bail and Slide Assembly Bracket has a machined surface at the threaded bearing end for the 119754 Shaft to accommodate a 3598 Lock Nut.

BULLETIN 1108B, Page 22

BULLETIN 1126B, Page 20

In the lower illustration, the "102186 Spacer - End" (with shoulder) should appear on the left and the "102184 Spacer - End" (without shoulder) should appear on the right.

BULLETIN 1108B, Pages 22 and 23

The 7614 Spring listed on Page 22 should be listed on Page 23, also on Page 22, a 41385 Spring should be listed in place of the 7614 and 55063 Spring.

NOTE: The 7614 Transfer Bail Spring (25 turns) is used only with the old style Transfer Bail Assembly Mounting Bracket. The 41385 Transfer Bail Spring (15 turns) is used only with the 115515 New Style Bracket (casting).

BULLETIN 1108B, Page 24

BULLETIN 1126B, Page 21

\*In the sensing contacts mounting parts the ten 7002 Washers have been replaced by ten 74722 Washers. Under the 102168 Post the 2191 Lock Washer has been omitted and the 7002 Washer has been replaced by a 74722 Washer (on Page 25 also in Bulletin 1108B). The 102089 Spacer - Long in the contact pileup has been replaced by a 102088 Spacer.

\*

\*

\*

### DISTRIBUTOR CAM SLEEVE ASSEMBLIES

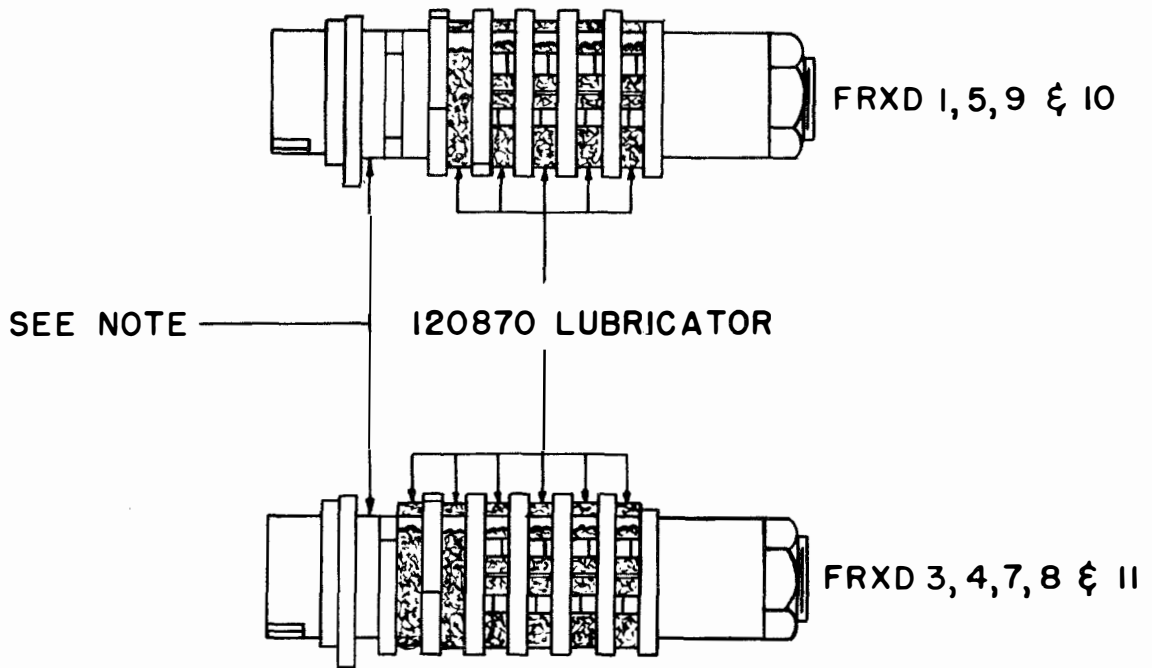

NOTE: THE 120870 LUBRICATOR IS REQUIRED IN THIS POSITION ONLY WHEN THE 123535 DETENT LEVER (FIGURE 6) IS USED.

### SENSING CAM SLEEVE ASSEMBLIES

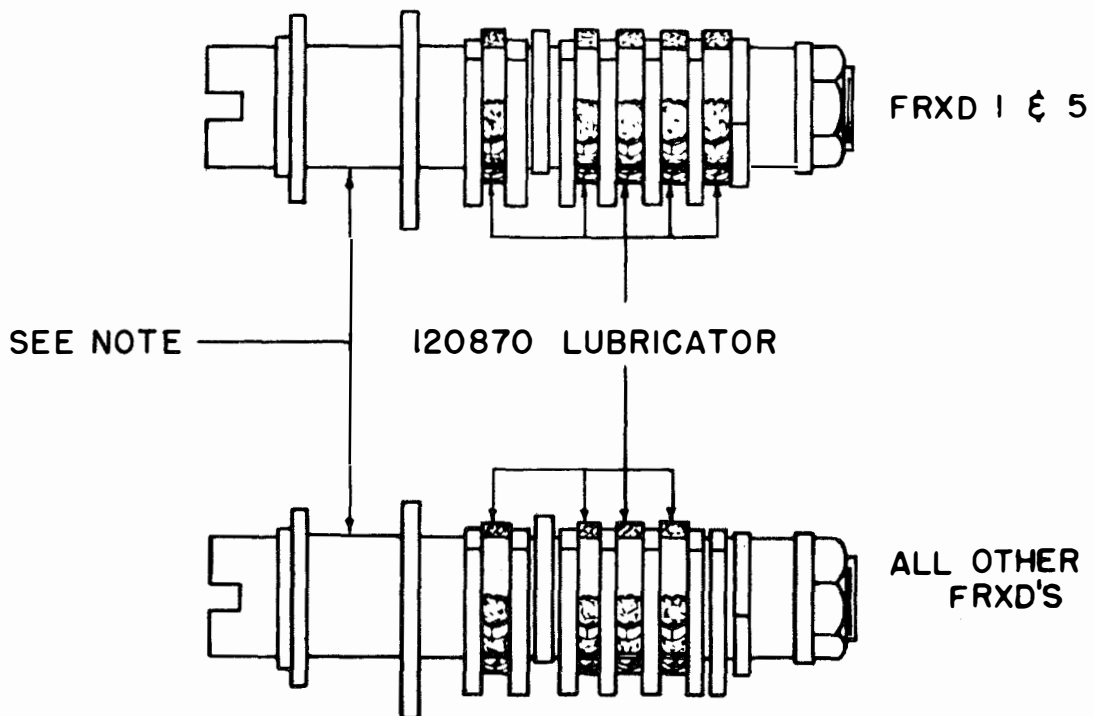

FIGURE 1

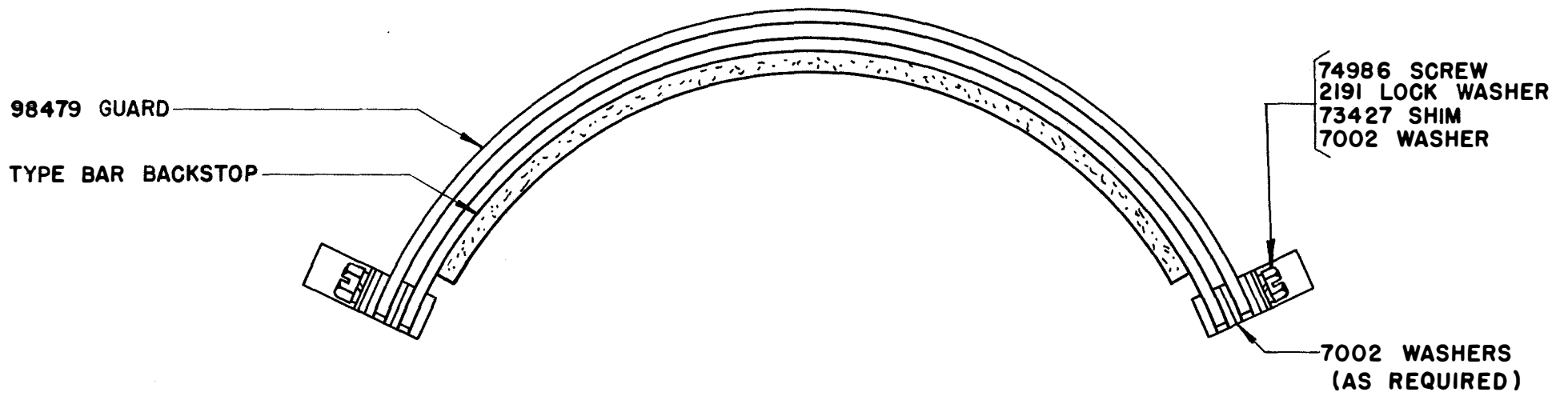

FIGURE 2

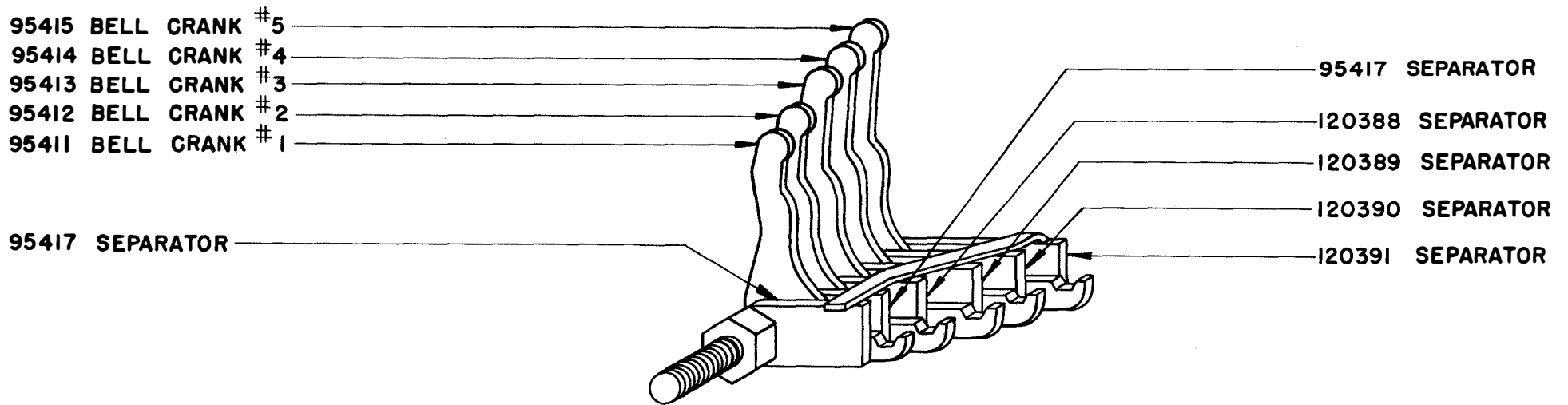

FIGURE 3

124134 TOOL, CONTACT BENDING

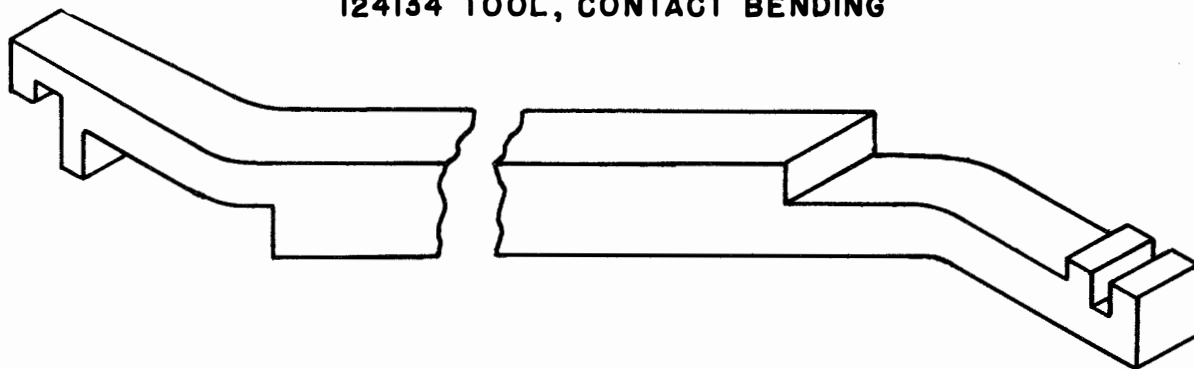

FIGURE 4

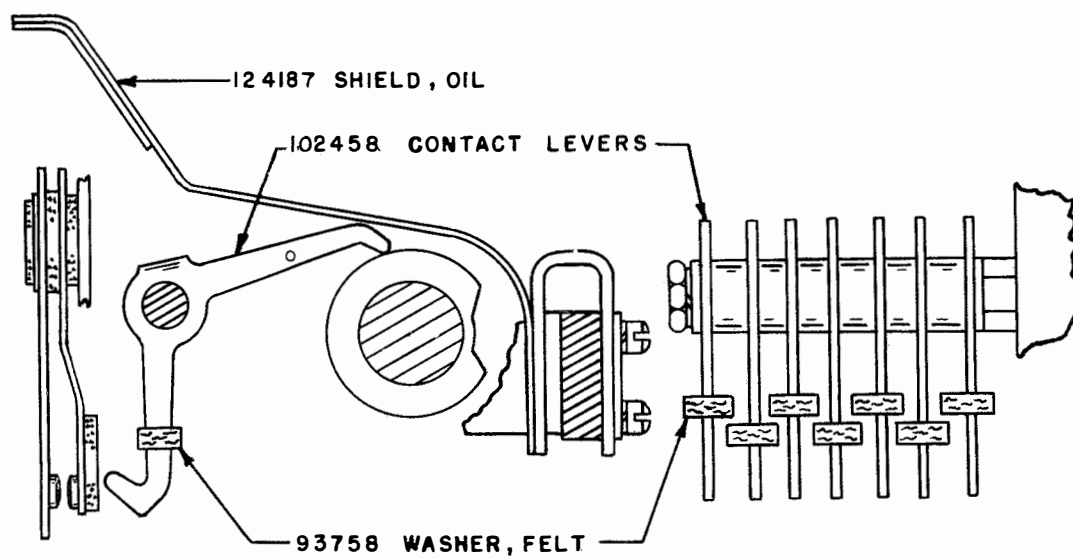

FIGURE 5

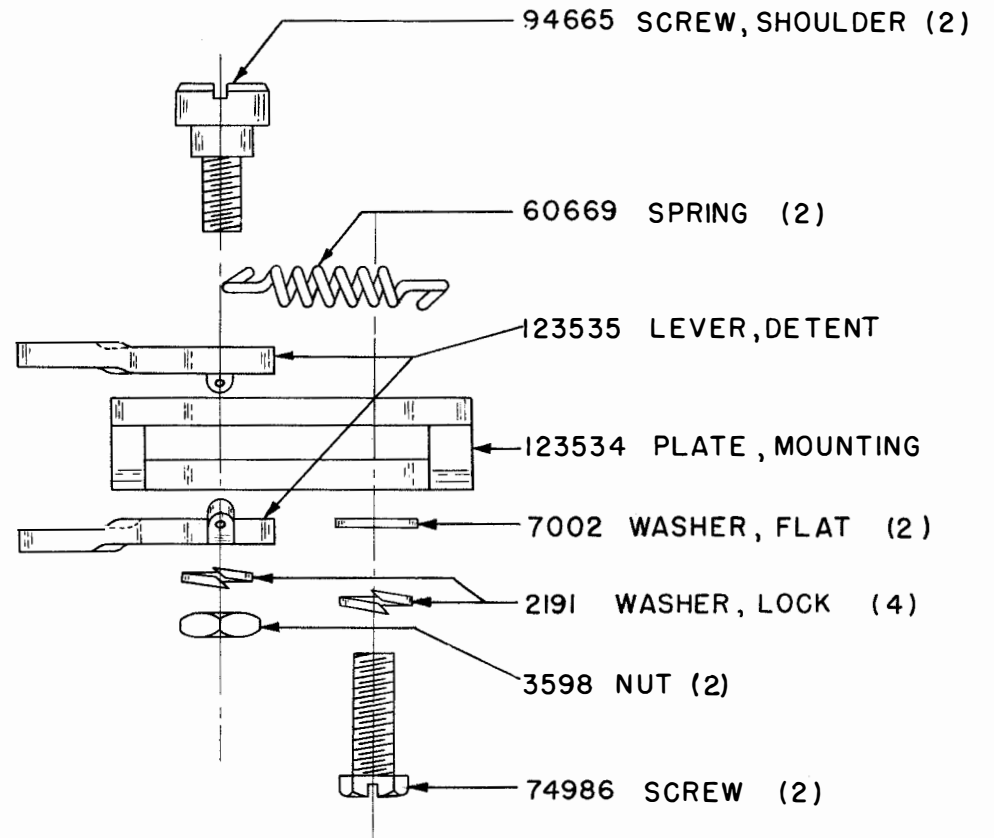
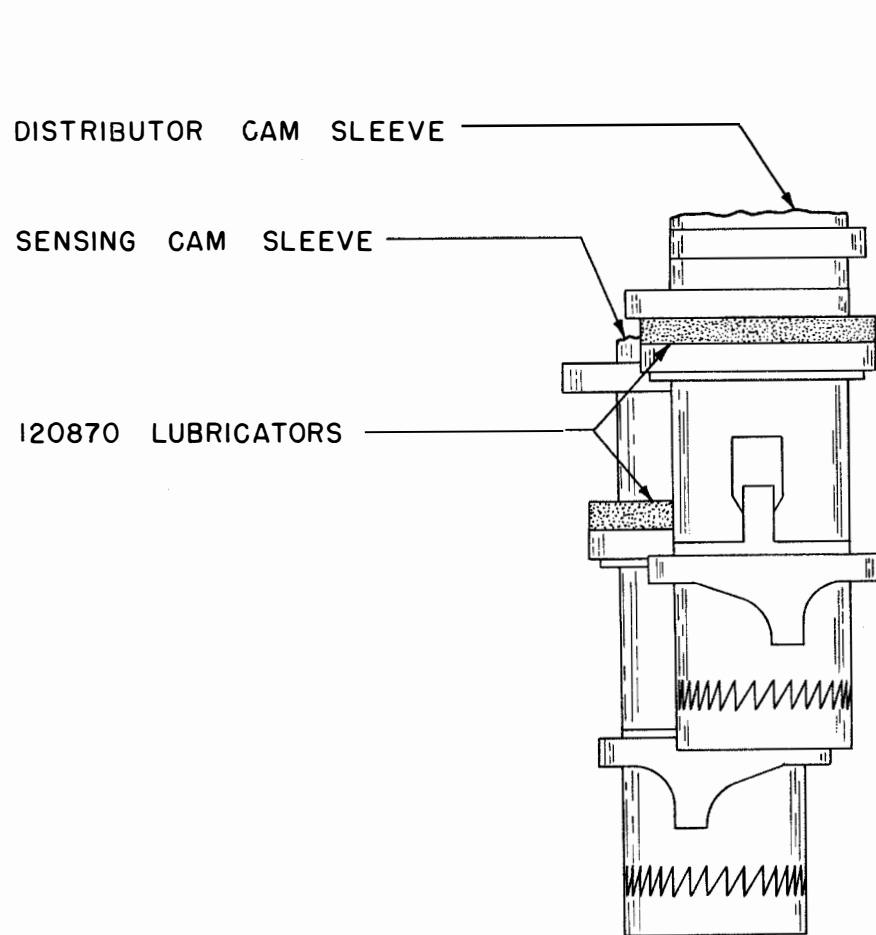

FIGURE 6



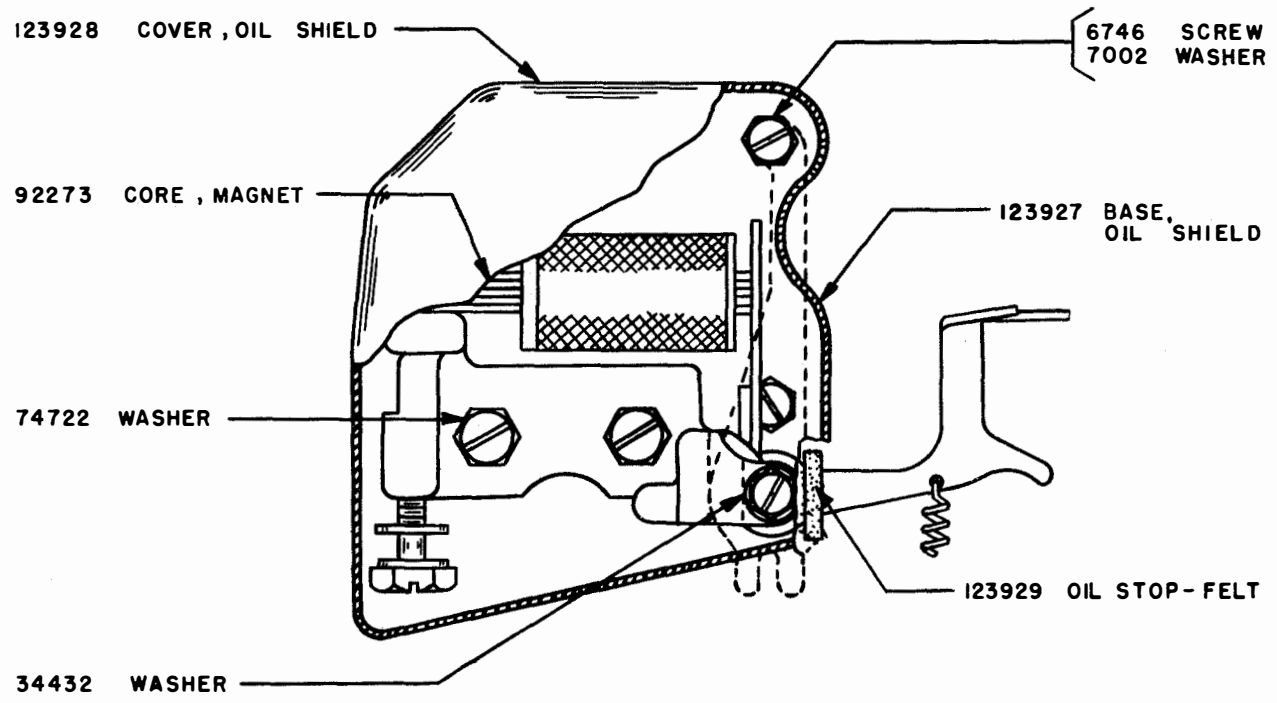

FIGURE 7



5  
1



1  
1

