

DESCRIPTION OF OPERATION OF NO. 15

TELETYPEWRITER

This section describes the operation of the No. 15 Teletypewriter. It has been issued principally for use in training Bell System teletypewriter repairmen. It is reproduced from material originally prepared for other purposes with such modifications as seem desirable to facilitate its use in conjunction with other Bell System practices in the proposed training work. The basic operating principles are described but no attempt has been made to include recent improvements and changes.

INDEX

DESCRIPTION OF THE MODEL 15

TYPEBAR PAGE PRINTER

	<u>PAGE</u>
GENERAL	2
Keyboard Transmitter	2
Signalling Code	2

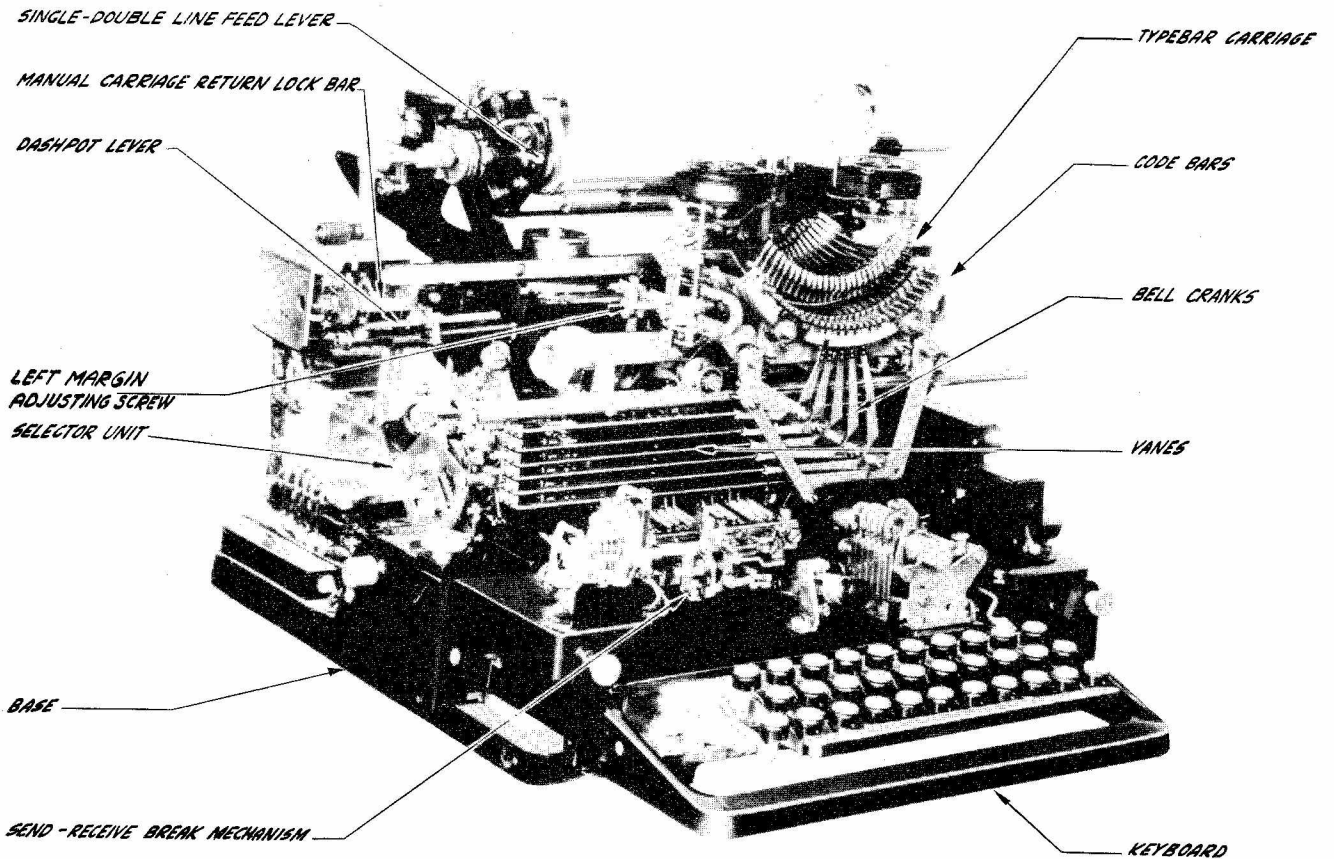

ILLUSTRATION 2.

This section contains material prepared by the Teletype Corporation and it is used with their permission.

<u>INDEX</u> (Cont'd)	<u>PAGE</u>
TYPING UNIT	4
Carriage Return	15
Figure Shift and Letter Shift	16
Functions	14
Keyboard Locking Mechanism	19
Line Feed Function	18
Locking Cam	7
Locking Function Lever	8
Main Shaft Assembly	5
Main Shaft Clutch Throwout Lever	8
Margin Signal Bell	12
Motor Stop Function	19
Printing	8
Ribbon Feeding	12
Ribbon Lockout	14
Ribbon Oscillation	13
Ribbon Reverse	13
Selecting Unit	5
Signal Bell Function	17
Sixth Vane	16
Spacing	10
Spacing Function	17
Unshift on Space Function	17
MOTOR SPEED CONTROL - MOTOR GOVERNOR	21
BASE UNIT	22
SYNCHRONISM	22
ORIENTATION	23
LINE TEST KEY	24
LINE RELAY	24

GENERAL

The No. 15 Teletypewriter is a machine designed for interchanging messages between two or more points. A sending-receiving machine consists of a keyboard transmitting unit, base, typing unit, and cover (Illus. 2).

The keyboard transmitting unit is used to send electrical impulses of the five unit code to the receiving mechanism of the typing unit at any station. These received signals will cause the typing unit to type a copy of the message sent by the keyboard operator.

Signalling Code

The signalling code used to transmit characters is the "Start-stop," five unit code which consists of five selecting impulses used in various combinations of current and no-current intervals. Each group of five selecting impulses is preceded by a start impulse and followed by a stop impulse used to maintain synchronism between all stations on the circuit. Impulses which operate the selector magnets are known as marking and those which do not are known as spacing. Fig. 1 shows graphically the code used.

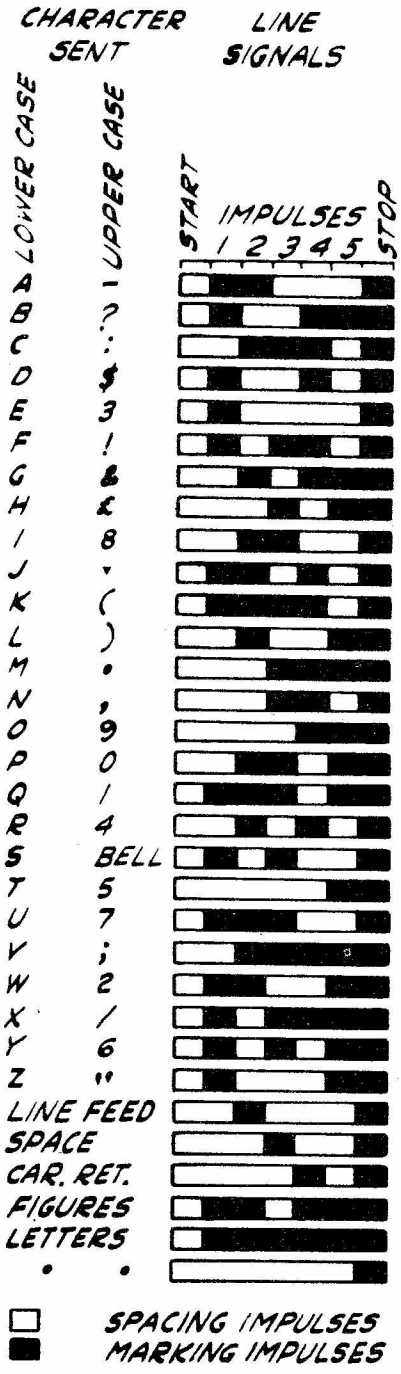

□ SPACING IMPULSES
 ■ MARKING IMPULSES

Fig. 1

Keyboard Transmitter

The keyboard (Illus. 3) consists of a set of keys, keylevers, a bank of sending contact springs, operating cams, clutch and gear. This gear engages with the transmitting shaft driving gear (Illus. 4). The sending cams are normally held stationary because the clutches on the driving shaft are held apart by the clutch throwout lever. When a key is

depressed the driven member of the clutch is permitted to move into mesh with the driving member causing the cam sleeve assembly to revolve. At the end of the revolution the driven member of the clutch is disengaged by the clutch throwout lever and the cams brought to a stop until the next key is depressed (Fig. 3).

Beneath the keylevers are five selector bars and a universal bar extending across the width of the keyboard. The selector bars are provided with saw tooth shaped notches as shown in Fig. 2 according to the requirements of the signalling code. These bars rest on rollers and are guided at each end so that they may be easily moved endwise. When a key is depressed the keylever strikes the slanting sides of these notches moving the bars either to the right or left depending upon whether the impulses corresponding to the bars are to be spacing or marking impulses.

The universal bar which is connected to the trip off pawl controlling the starting and stopping of the sending cams is pivoted at its two ends in such a way that the depressing of any key moves it downward to actuate the clutch throwout lever. Thus, whenever a key is depressed the selector bars are set and the universal bar is moved down permitting the sending cams to start rotating (Fig. 3).

Each selector bar engages a vertical locking lever at its right hand extremity and positions it to correspond with the signal impulses to be transmitted (Fig. 2). Each locking lever controls the motion of a contact lever by either allowing the contact lever to close its contact when the cams revolve or restricting the motion of the contact lever. If the upper end of the locking lever is positioned to the left corresponding to a spacing impulse, it engages the contact lever and prevents it from rising into the indent of the cam as it rotates, thus holding the circuit open for that impulse (Fig. 2-A). If the locking lever is positioned to the right corresponding to a marking impulse it does not interfere with the movement of the contact lever (Fig. 2-B). Then as the cam revolves the contact lever rides on the cam surface and rises into an indent thereby allowing its contact to close, sending out a marking impulse. As the cams rotate the impulses, either marking or spacing, are transmitted in succession.

The start-stop cam controls an additional contact lever which in turn actuates the start-stop contacts (Fig. 3). These contacts are opened at the beginning of each revolution of the cam shaft to transmit the start impulse

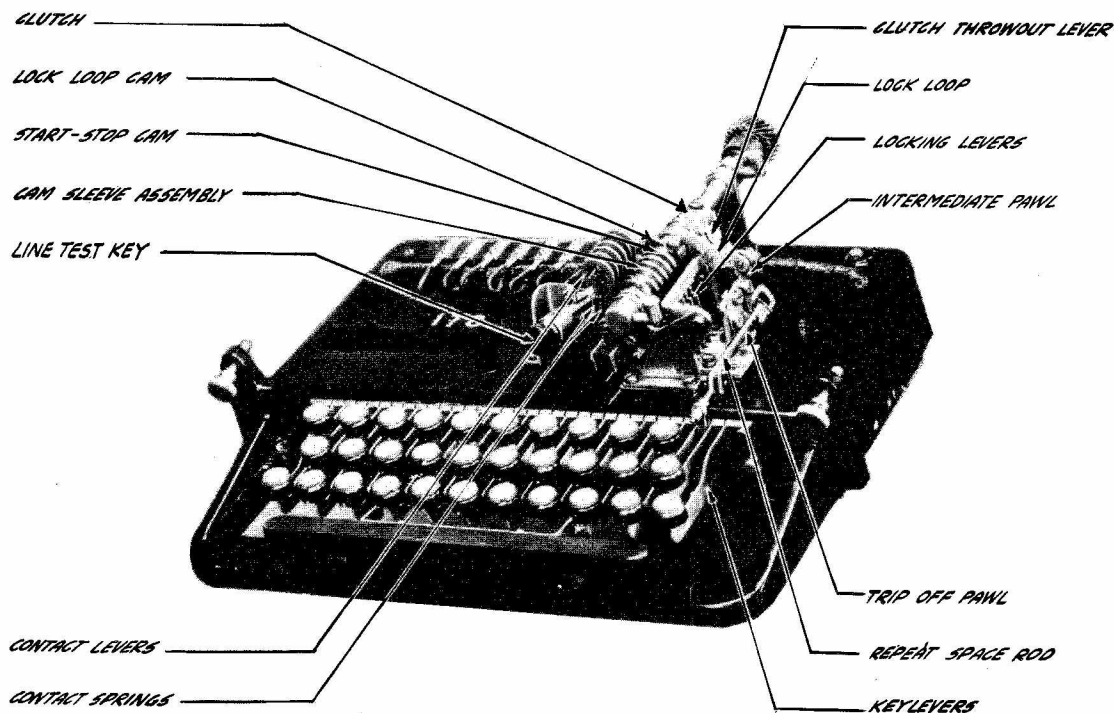

KEYBOARD
ILLUSTRATION 3.

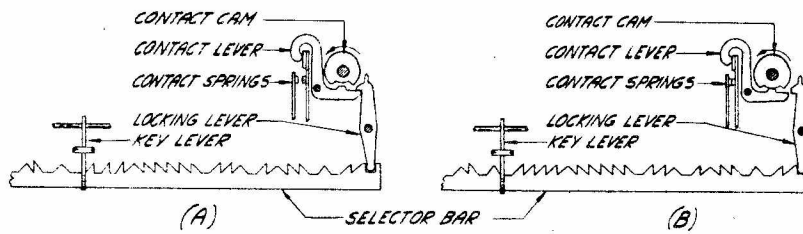
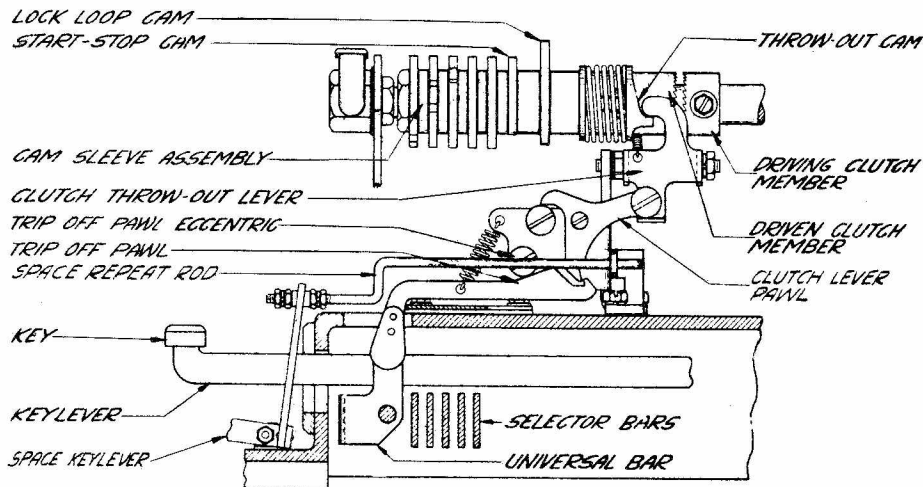

Fig. 2



(SEE ILLUSTRATION 3)

Fig. 3

(spacing) and remain open during the transmission of the five impulses. After the fifth impulse has been transmitted, the start-stop contacts will again close sending the stop impulse (marking) to the line. These contacts will remain closed until the next keylever is depressed. At the end of the revolution the clutch driven member is cammed out of mesh with the driving member and prevents the cams from rotating further until the next key is depressed. The lock loop which is raised by the lock loop cam at the end of each revolution to allow the new combination to be set up is used while in its down position to prevent a change in the selection set up (Illus. 3). This is done by holding the locking levers in their set positions while the signals are being sent out. This arrangement also makes it impossible to depress another key until the signal for the previous character has been transmitted.

The keyboard is equipped with a space repeat device which permits the transmission of continuous spaces. (Illus. 3.) When the space keylever is depressed, the space repeat rod attached to the keylever extension will move the clutch lever pawl forward in turn holding the clutch throwout lever out of

engagement with the projection on the driven clutch. Thus the transmitter cam sleeve will be permitted to revolve continuously until the space keylever is released.

TYPING UNIT

The typebar carriage of the Model 15 typing unit consists of typebars similar to those of a typewriter together with other associated parts. The typebars are mechanically thrown against a platen causing letters to be printed. The typebar to be selected is determined by the setting of five code bars which are actuated by line signals through the medium of the selector mechanism. The code bars are so arranged that the notches on their upper sides will be lined up permitting a selected pullbar to move down into the path of the pullbar bail. This bail moves the pullbar forward causing the typebar to which it is connected to strike the platen. Illustration 2 shows the typing unit mounted on the base with a keyboard.

The various functions; line feed, space, carriage return, figure shift, letter shift, etc. are also accomplished mechanically. A

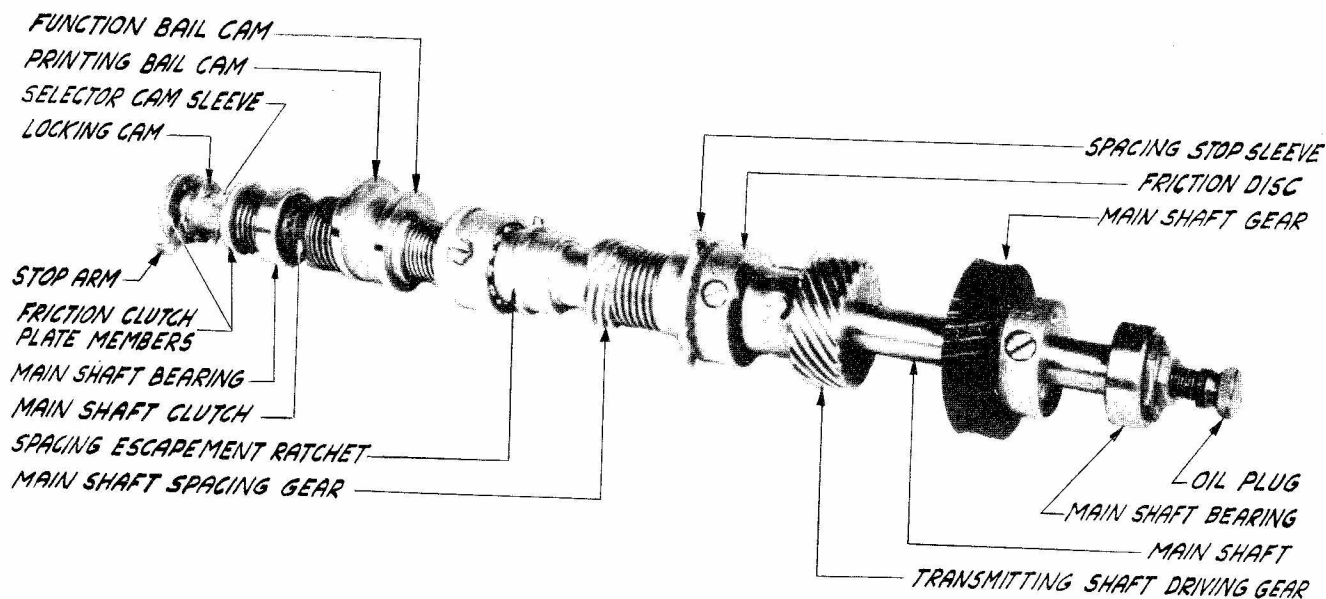

**MAIN SHAFT ASSEMBLY
ILLUSTRATION 4.**

motor drives the main shaft assembly of the typing unit which supplies power to all mechanically operated parts.

Main Shaft Assembly (Illus. 4).

The main shaft gear is located near the right end of the shaft and meshes with the motor pinion. Thus it may be seen that the main shaft will be caused to rotate continuously during the period the printer is in operation. The main shaft also operates the keyboard cam shaft through the medium of the transmitting shaft driving gear.

The main shaft spacing gear meshes with the spacing shaft gear to provide the spacing action at the required time (Illus. 8). The spacing escapement ratchet, sleeve and friction discs are associated with the spacing mechanism and are described under "Spacing." The function bail cam and the printing bail cam operate their respective bails. The main shaft clutch is used in conjunction with the selector to provide power to operate the printing and function bails immediately after the selection has been completed. The selector cam sleeve is fitted over the left end of the main shaft and is driven through the medium of a friction clutch.

Selecting Unit

The purpose of the selecting unit is to receive the signals from the transmitting

station, distributing them mechanically, thereby setting up various combinations on the vanes. These combinations will determine the character to be printed or the function to be operated. The selector mechanism is controlled by the magnet which receives the code impulse from the line. Normally the armature of this magnet is pulled up and the stop arm is against the stop lever which in turn is held by the trip latch. Because the stop arm which is a part of the selector cam sleeve is engaged with the stop lever, the cam sleeve is prevented from revolving (Fig. 4).

When the start impulse which is spacing (no current) is received the armature is released and pulled away from the magnet pole pieces by the armature spring. This will move the trip latch out of engagement with the stop lever thereby releasing the stop arm allowing the cam sleeve to revolve with the main shaft.

Each vane is operated by a selector cam through a "T" lever, a sword and a selector lever (Fig. 5). For instance, suppose that the code for the letter "E" is received. Upon the reception of the start impulse (a no current impulse), the armature moves away from the magnet, imparting motion first to the trip latch plunger (Fig. 4), which in turn causes the bell crank to move the trip latch out of engagement with the stop lever releasing the stop arm as explained previously. The selector cams start to revolve and the number 1 selector cam engages number 1 selector lever,

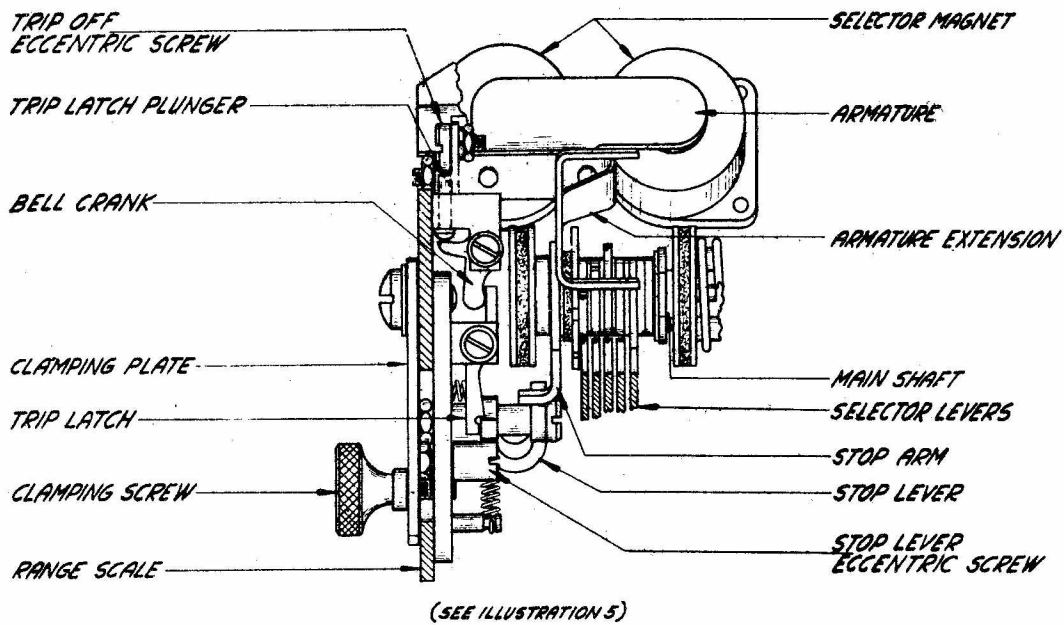
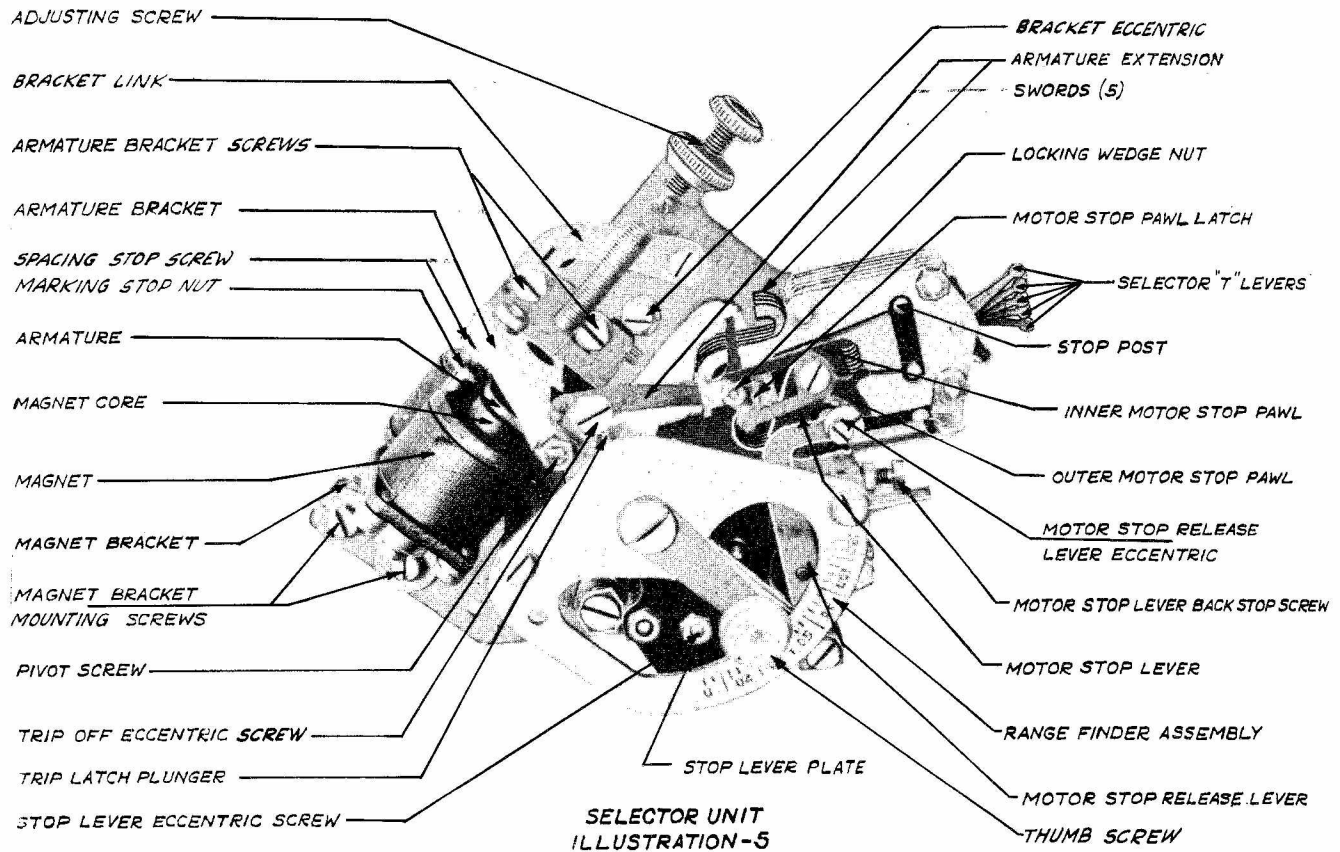

Fig. 4

when the first impulse of the letter "E" (Marking or current impulse) has been received by the magnets from the line. The magnet armature is therefore pulled up, bringing the upper end of the armature extension up into the path of the upper sword arm. When the number 1 cam passes the number 1 selector lever, this lever is rotated counterclockwise, carrying with it the sword, which strikes the upper end of the armature extension and is in turn rotated clockwise about its pivot, point A. This positions the sword so that when the number 1 cam clears the selector lever, the selector lever spring moves the sword against the "T" lever and brings the front edge of the number 1 vane down. As no current is received while number 2, 3, 4 and 5 cams are passing their selector levers, the magnet armature is released and the armature extension moves down so that the lower end of the armature extension is in the path of the lower sword arm (Fig. 5). As the number 2, 3, 4 and 5 cams pass the number 2, 3, 4 and 5 selector levers the number 2, 3, 4 and 5 vanes are moved so that the front edges are up. With the front edges of the vanes in the upper position the corresponding code bars will be moved to the right or unoperated position through the medium of the bell cranks (Illus. 2). With the

front edges of the vanes in the lower position the corresponding code bars will be moved to the left or operated position. With the number 1 code bar to the left and number 2, 3, 4 and 5 code bars to the right, there is a notch in each code bar opposite the "E" pullbar. The sixth cam releases the main shaft clutch allowing the printing and function bail to make one complete revolution (Fig. 8). The printing bail cam will permit the printing bail to be pulled forward by its spring. The "E" pullbar will be pulled down by its spring into the path set up by the code bars and the pullbar bail, actuated by the printing bail, will carry the pullbar forward causing the type bar to strike the platen printing the letter "E" (Fig. 9).

Locking Cam

The locking cam has five low and five high portions on its periphery against which the locking lever is held by its spring (Fig. 6). During that part of each impulse when the swords are set by striking against the armature extension (at the time the peak of any selector cam is operating the corresponding selector lever) a low portion of the locking cam is opposite the locking lever. The armature

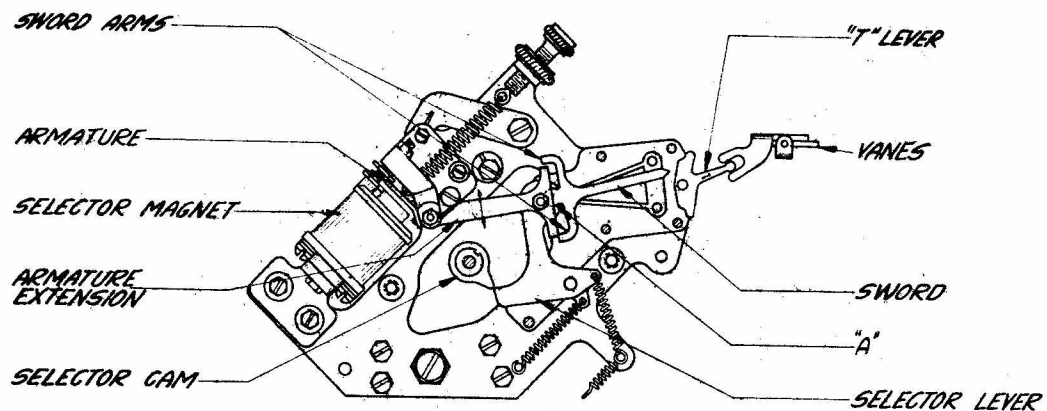

(SEE ILLUSTRATION 5.)

Fig. 5

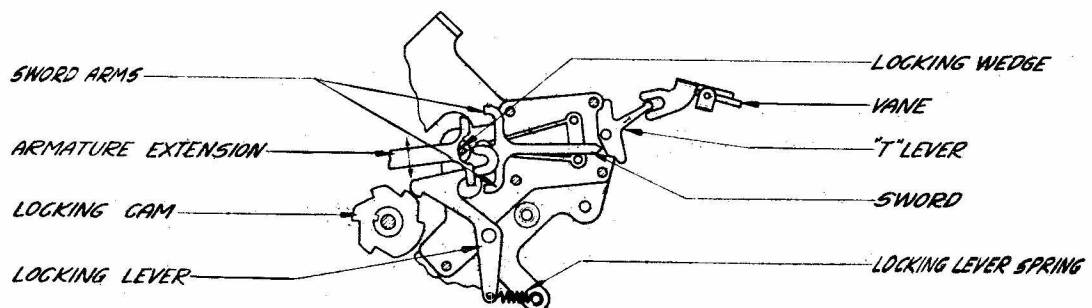

(SEE ILLUSTRATION 5.)

Fig. 6

will now be held firmly in position by the "U" shaped extension of the locking lever engaging the locking wedge on the armature extension. When the locking lever is riding on the high portion of the locking cam the locking lever extension will be held away from the locking wedge and the armature will be free to move in response to the next impulse.

Locking Function Lever

It is obvious that the vanes are held in their selected positions until the printing of the character has taken place. This is accomplished by means of the locking function lever. The locking function lever is the first on the right of the function levers, which are located immediately behind the vanes (Fig. 7). When the printing bail is in its rear position, the function lever bail, mounted on the printing bail casting, is holding the locking function lever away from the vanes. When the printing bail is permitted to move forward, the function lever bail roller moves down, allowing the function lever spring to pull the lever against the rear edges of the vanes. The locking function lever will engage each vane, whether its rear edge be raised by a marking impulse or brought down by a spacing impulse, locking the vanes in their selected positions.

The operation of the remaining function levers is dealt with under "Functions."

Main Shaft Clutch Throwout Lever

As previously described, the sixth cam on the selector cam sleeve releases the main shaft clutch allowing the printing and function bail cams to make one complete revolution (Fig. 8). At the end of each revolution of the printing and function bail cams the clutch stop arm engages with the projection on the driven clutch member and cams it out of mesh with the driving clutch member. Immediately after the fifth impulse has been received the peak of the sixth cam strikes the clutch throwout lever cam arm moving the lever stop arm out of engagement with the projection on

the driven clutch member. This will permit the spring to move the driven clutch member in to mesh with the driving member. Thus it may be seen that immediately after the completion of the selection of any character or function the printing and function bail cams will be permitted to revolve one revolution which will effect the printing of that character or the operation of that function. From the foregoing it may be seen that any character or function may be selected while the printing of the previous selection is taking place.

Printing

The printing bail operating arm is mounted on the bail mounting shaft on which is also mounted the printing bail, function bail and spacing escapement pawls (Illus. 9). The printing bail spring attached to the right-hand end of the printing bail casting holds the printing bail against the upper end of the operating bail arm and the operating arm roller against the printing bail cam on the main shaft. Thus it will be seen that the printing bail cam will determine the position of the printing bail at all times (Fig. 9).

The actual printing of any character is not caused directly by the printing bail, but by the pullbar bail which it controls. The pullbar bail is attached to the pullbar bail plunger on the lower surface of which is attached the plunger roller (Illus. 6). This roller (when the typebar carriage is in place) is located between the printing bail blades (Fig. 9). This arrangement will permit the carriage to move from left to right and also allow the pullbar bail to be moved backward and forward by the printing bail regardless of the position of the typebar carriage.

At the end of each revolution of the printing bail cam, the printing bail operating arm roller will be on the high portion of its cam (Fig. 9 & Illus. 9). The printing bail will be in its rearmost position, carried there against the tension of its spring.

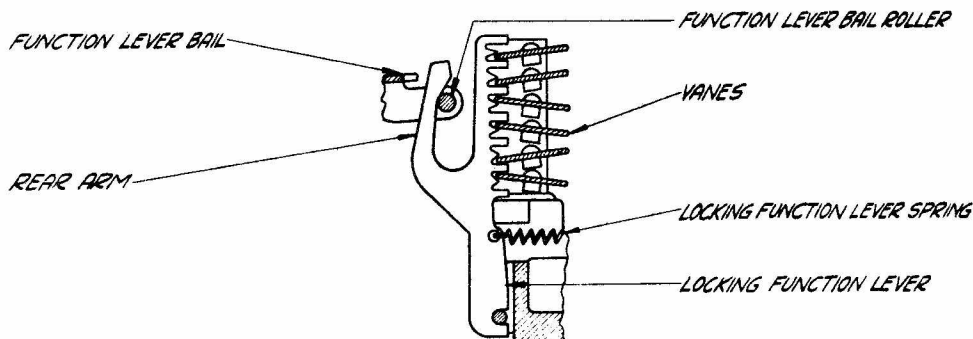
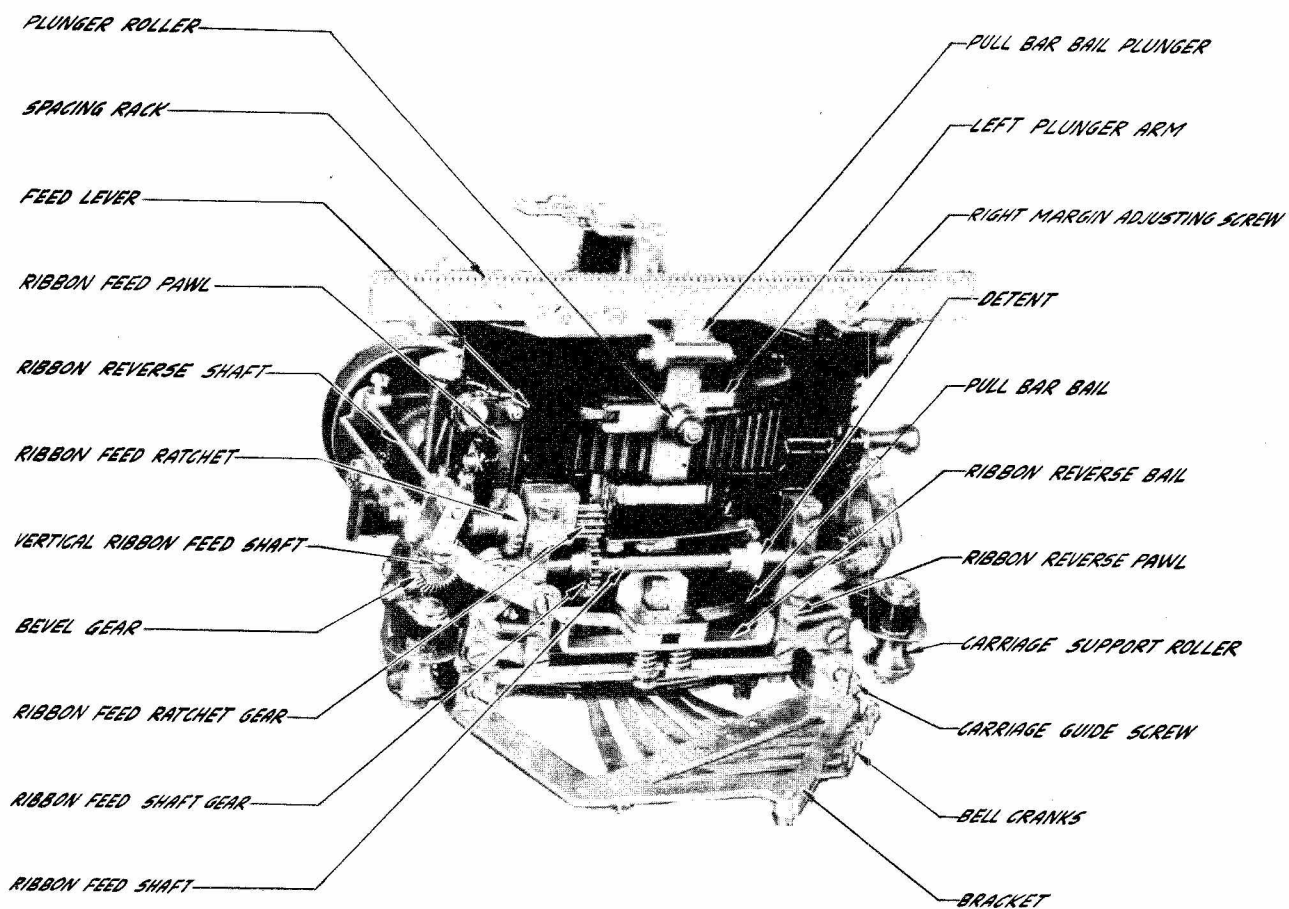
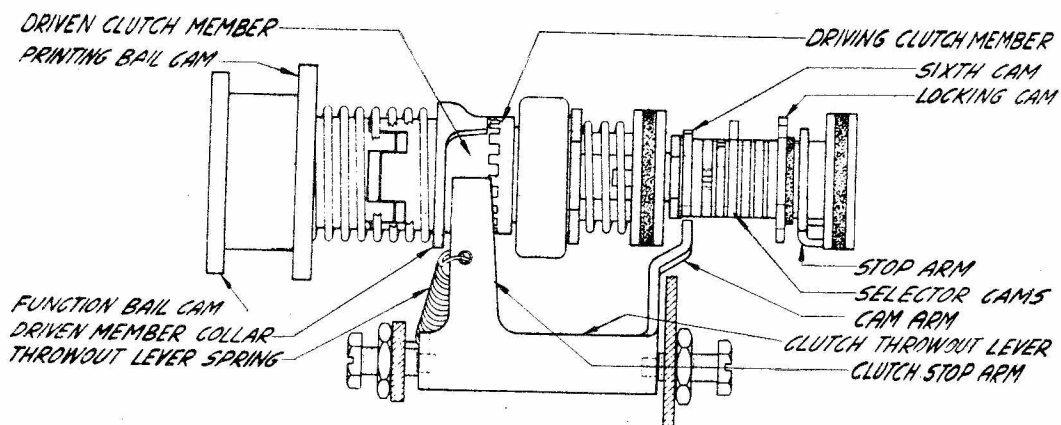

Fig. 7



BOTTOM VIEW TYPEBAR CARRIAGE
ILLUSTRATION 6



REAR VIEW
(SEE ILLUSTRATION 4.)

Fig. 8

As the printing bail cam revolves, the roller on the printing bail operating arm will move against the low portion of the cam. The printing bail will follow the upper end of the operating arm, being pulled forward by its spring, and will move the pullbar bail forward. The forward motion of the pullbar bail will first allow all of the pullbars to be pulled down against the code bars by their respective springs, the selected pullbar being pulled down further than the rest, into the path set up for it in the code bars. As the pullbar bail continues on its forward stroke, it will engage the notch in the selected pullbar only, (the remaining ones being too high for their notches to engage), and carry the pullbar forward, throwing the typebar which is geared to it against the platen printing the character. Fig. 9 shows a cross-section of the typing unit.

The operating arm roller will again ride up onto the high portion of the printing bail cam as it completes its revolution. Thus the operating arm brings the printing bail back to its rearmost position and in turn the pullbar bail which is engaged in it. When the pullbar bail is in its rear position all of the pullbars are moved by it sufficiently high to

clear the code bars so that they are free to move in either direction. The combination for the succeeding letter then takes its place in the code bars and the printing operation is repeated as described in the foregoing.

Spacing

On the Model 15 Printer the typebar carriage is moved to accomplish the spacing. The typebar carriage is supported on two tracks. The upper track is a rectangular rod and is located to the rear. The lower track is a circular rod and is located above the vanes (Fig. 9 & Illus. 7). The typebar carriage is moved by the spacing gear which is meshed with the spacing rack and is facilitated by three carriage support rollers, two of which operate on the front track and one on the rear track. The front track is slotted throughout its length, so that the heads of two carriage guide screws located at either side of the carriage casting, will be guided therein (Illus. 6).

The spacing rack is mounted on the rear of the typebar carriage casting and meshes with the spacing gear which is fastened to the upper end of the spacing shaft (Illus. 8).

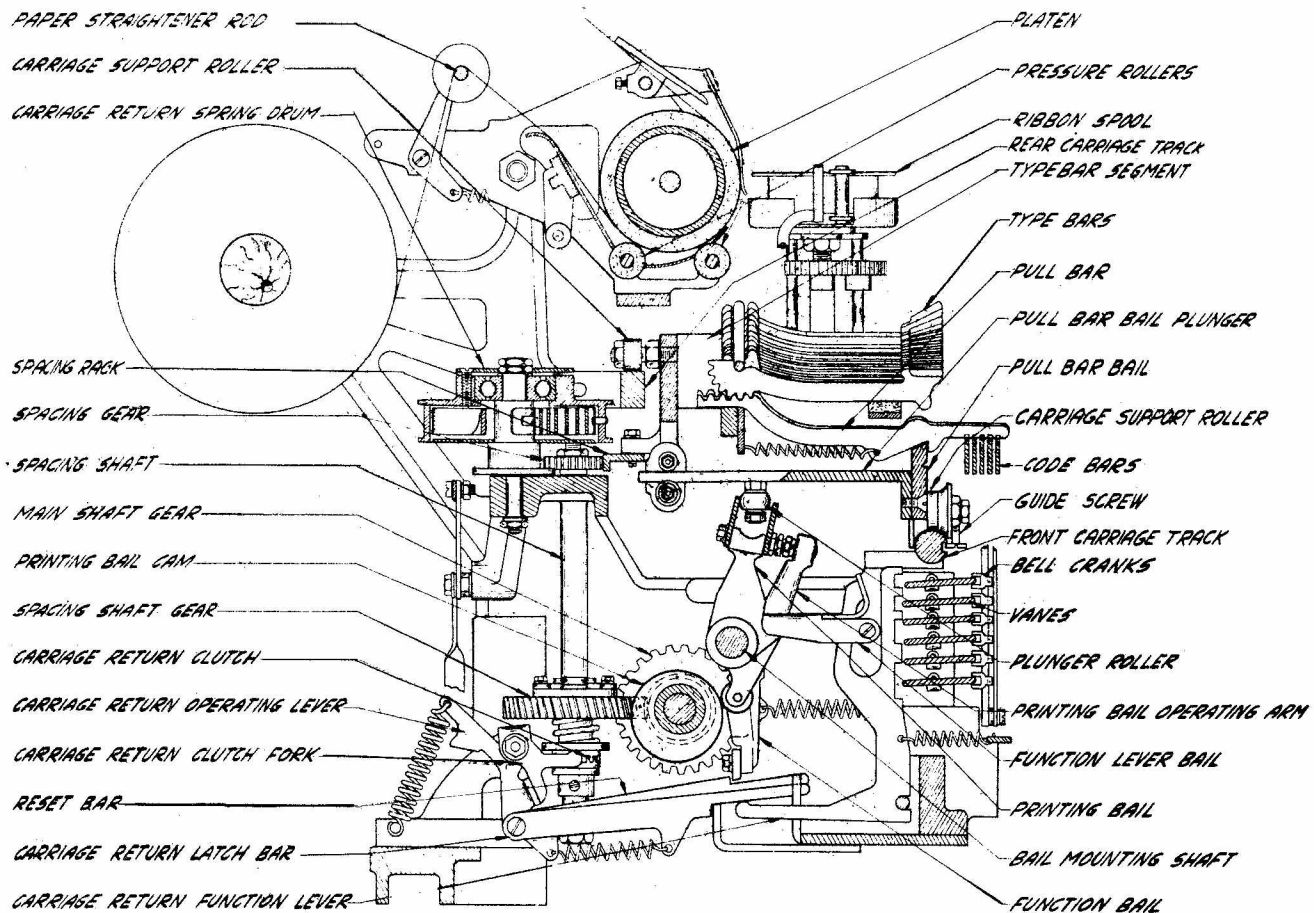

Fig. 9

The spacing shaft gear is located at the lower end of the spacing shaft and meshes with the main shaft spacing gear. The lower half of the carriage return clutch is fastened to the spacing shaft (Fig. 9). The upper half of the clutch forms a sleeve on the spacing shaft to which the spacing shaft gear is attached. The carriage return clutch members are in engagement at all times except when the carriage is returning from the end of a line. The function of this clutch is described under "Carriage Return."

The main shaft spacing gear is a part of the sleeve of a friction clutch assembly. It consists of the spacing ball bearing screwed to the shaft, a spacing escapement ratchet, a friction disc and felt washer, a spacing stop sleeve and a clutch spring (Illus. 4). The main shaft spacing gear will revolve with the main shaft unless stopped by holding either the spacing stop sleeve or the spacing escapement ratchet.

When the typebar carriage reaches the end of its travel at the right end of the printer, the right margin adjusting screw (Fig. 10-A) moves the spacing stop lever into the path of a projection on the spacing stop sleeve. This prevents spacing at the end of the carriage travel.

The spacing escapement ratchet is regulated by the front and rear escapement pawls which are mounted on the bail mounting shaft. With the printing bail in its rear position, the rear escapement pawl is engaged in one of the teeth on the spacing escapement ratchet, holding the spacing gear sleeve (Fig. 10-B). As the printing bail starts to move forward the operating arm strikes the lower end of the rear pawl, moving it out of engagement with the tooth on the escapement ratchet. At the same time the front escapement pawl moves down against the escapement ratchet into the path of another tooth which it will engage after having traveled one-sixth of a space. The printing operation then takes place. Near the

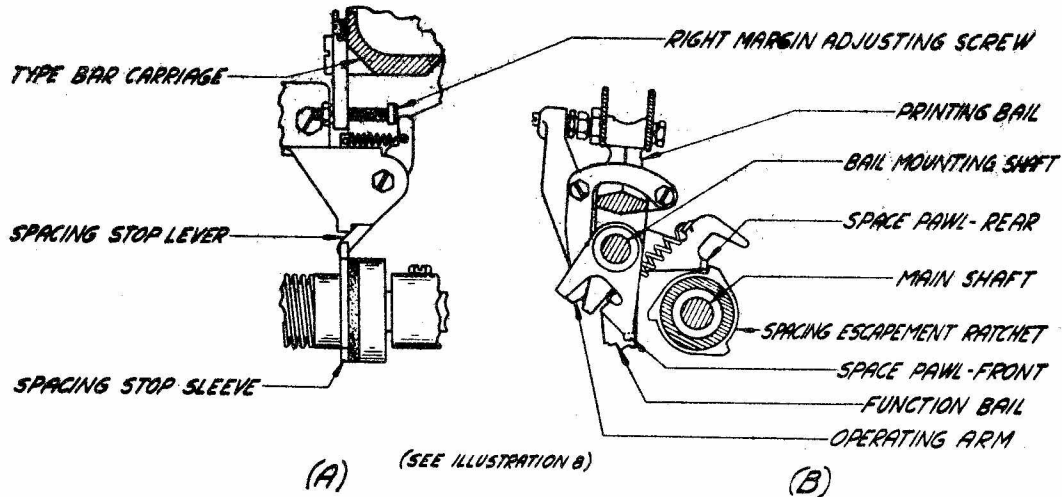
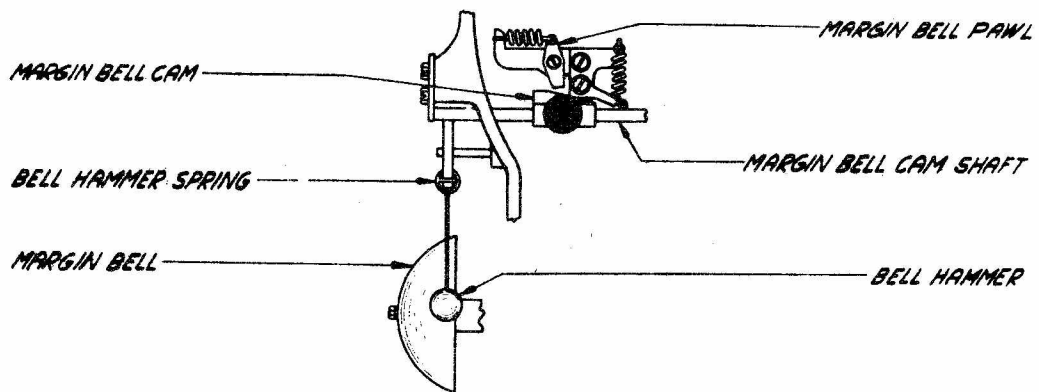
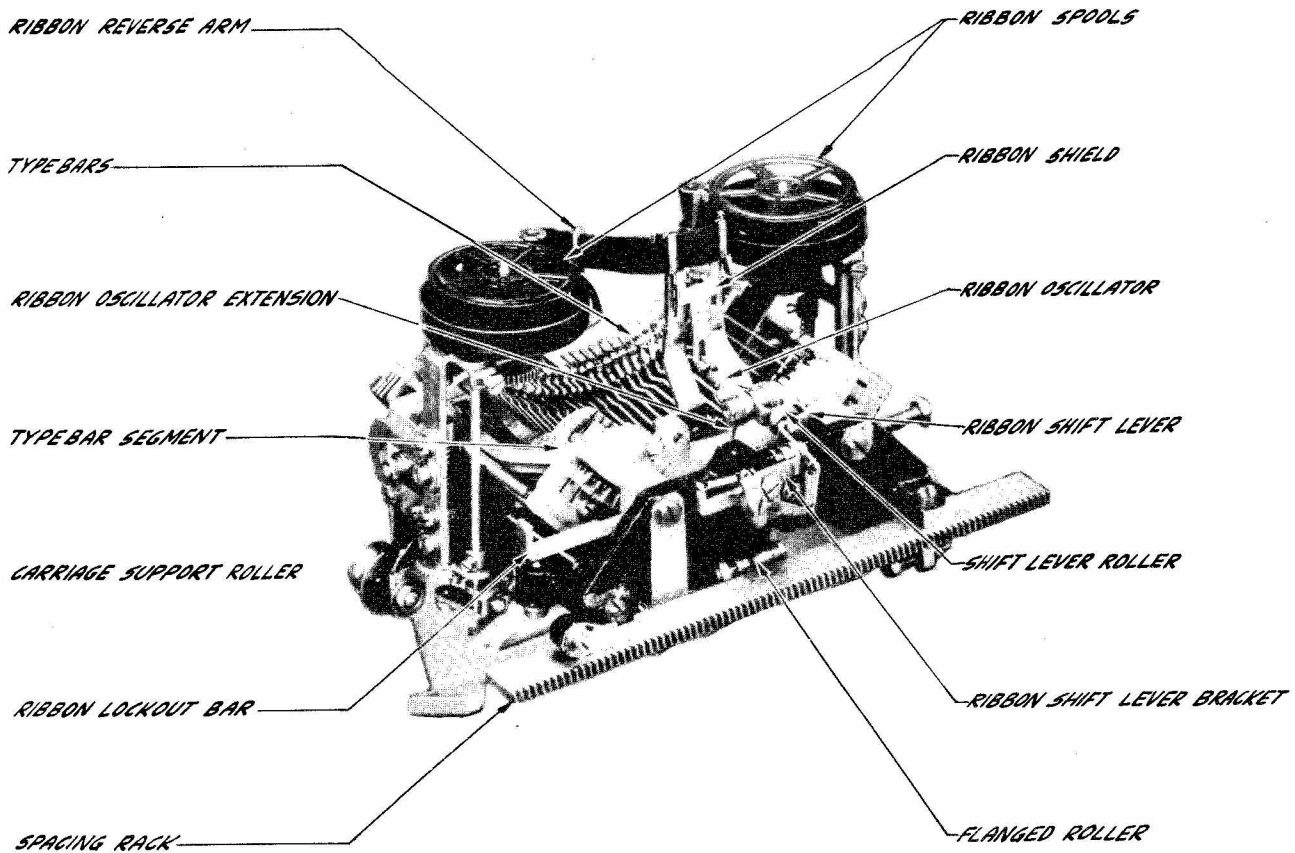

Fig. 10



(SEE ILLUSTRATION B)

Fig. 11



REAR VIEW TYPEBAR CARRIAGE
ILLUSTRATION 7

end of the return stroke of the printing ball, the escapement pawl operating arm lifts the front escapement pawl out of engagement with the escapement ratchet and at the same time the rear pawl moves against the ratchet. This will allow the spacing gear to revolve far enough to complete the remaining portion of the space at the end of which time the rear escapement pawl will engage a tooth on the ratchet.

Margin Signal Bell

Before the typebar carriage reaches the end of its travel, it operates the margin bell

as a warning to the operator that the end of the line is near (Fig. 11 & Illus. 8). The margin bell pawl on the typebar carriage will depress the margin bell cam, tipping it, moving the bell hammer away from the bell against the tension of its spring. When the typebar carriage bell pawl has been spaced beyond the cam, the bell hammer will be released and its spring will pull the hammer against the bell.

Ribbon Feeding

The end of the ribbon feed lever engages with the notched extension on the pullbar bail

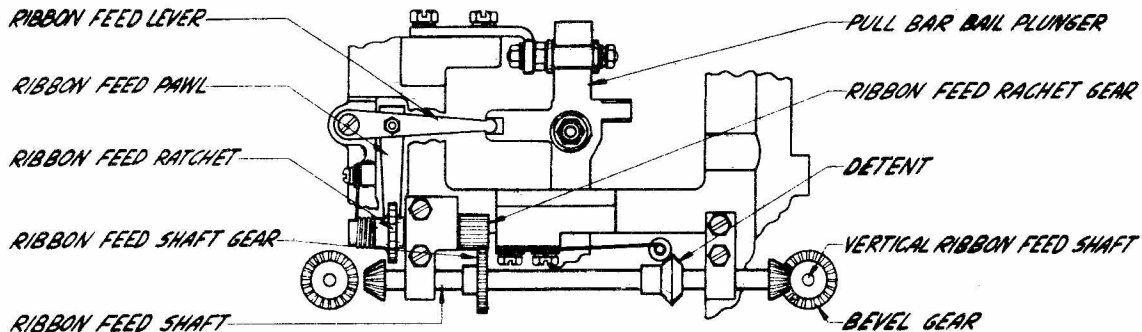

(SEE ILLUSTRATION 6.)

Fig. 12

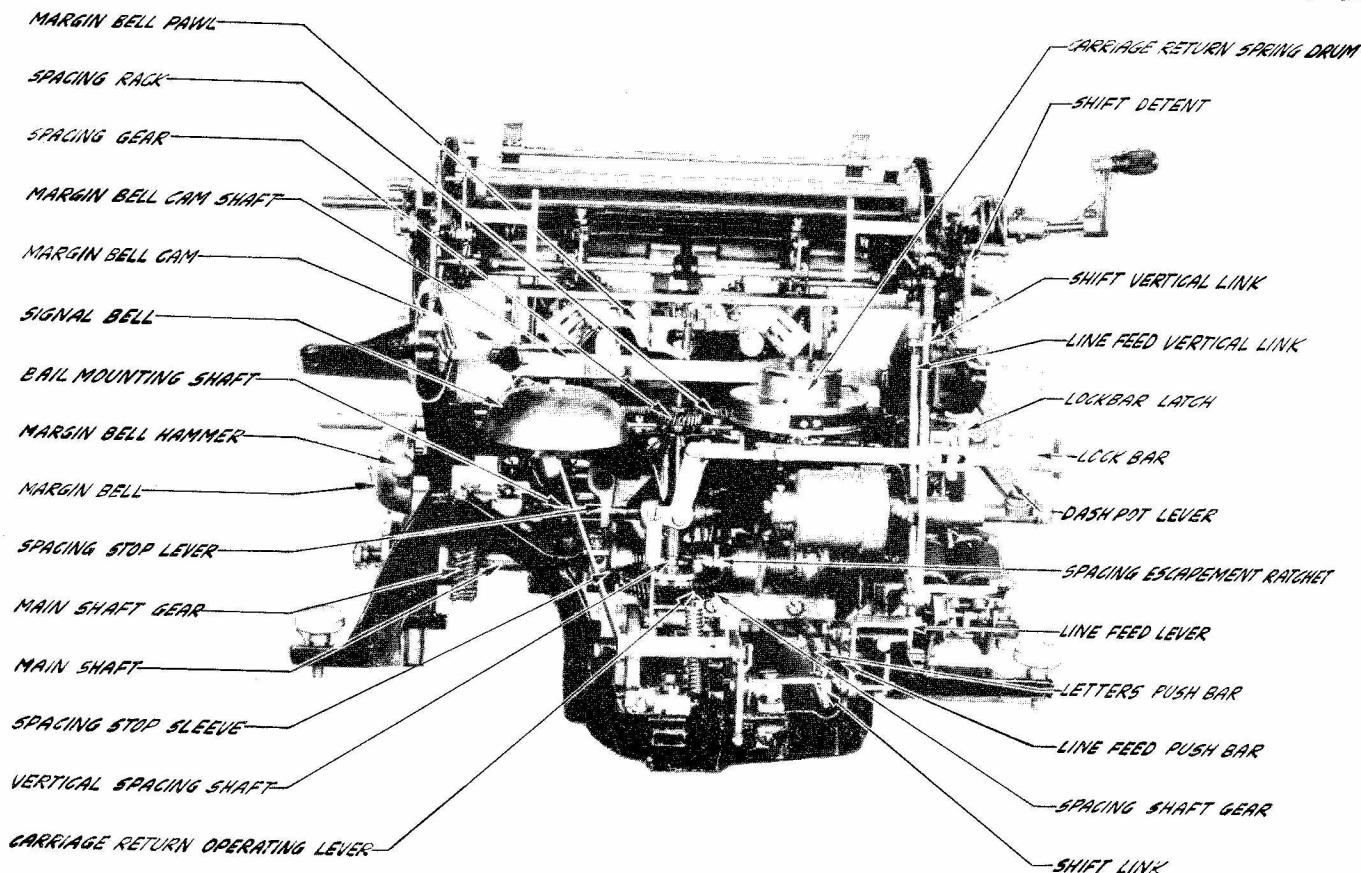

REAR VIEW TYPING UNIT
ILLUSTRATION 8

plunger (Fig. 12). The ribbon feed pawl, which actuates the feed ratchet, is attached to the ribbon feed lever. With each operation of the pullbar bail plunger the ribbon feed ratchet and the ribbon feed ratchet gear, which is attached to a common shaft, is advanced one tooth. This motion is carried through a train of gears and shafts, causing one of the ribbon spools to be revolved.

Ribbon Reverse

Assuming that the ribbon is being wound on the right-hand spool and is almost unwound from the left-hand spool, an eyelet which is fastened to the ribbon will engage and move the left-hand ribbon reverse arm. This arm moves the left-hand ribbon reverse pawl into

the path of the ribbon reverse bail (Fig. 13). As the bail moves toward the rear it engages the pawl, moving the ribbon feed shaft to the left. This will disengage the right-hand ribbon feed shaft gears and engage the left-hand gears. The ribbon will then be wound on the left-hand spool. The reversing operation takes place in a similar manner on the right side of the assembly when the eyelet near the right end of the ribbon engages with the right-hand ribbon reverse arm.

Ribbon Oscillation

So as not to obscure the printing, the ribbon is moved below the printing line after each character has been printed. This is accomplished by the ribbon oscillator which is

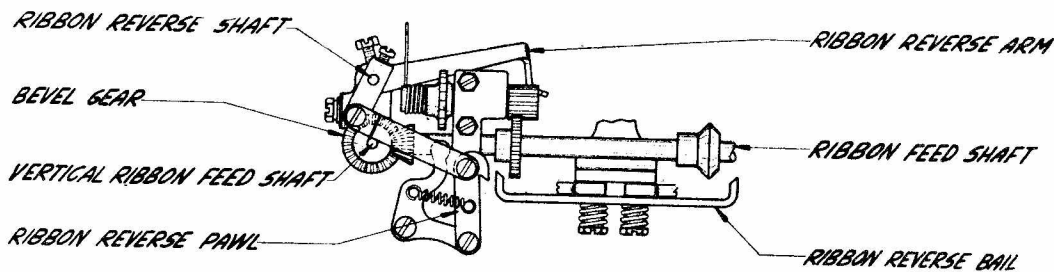

(SEE ILLUSTRATION 6.)

Fig. 13

actuated by the movement of the pullbar bail plunger (Fig. 14). Normally the ribbon is held below the printing line by the pullbar bail plunger when in its rear position. The forward movement of the pullbar bail plunger will permit the oscillator spiral spring to move the ribbon shield upward carrying the ribbon into the path of the typebars.

The height to which the ribbon oscillator will raise the ribbon is determined by the position of the shift lever roller. Both the oscillator and the extension are pivoted on the ribbon shift lever. The shift lever spring holds the shift lever roller against the slide bar, which is mounted on the platen assembly (Illus. 9). When the platen shifts to the "Figures" position the shift lever roller moves up with the slide bar and allows the shift lever spring to pull the ribbon oscillator assembly and ribbon to the higher printing line.

Ribbon Lockout

The ribbon lockout bar is provided for the purpose of locking the ribbon below the printing line when stencils are being made (Illus. 7). When the ribbon lockout bar is

moved inward manually, it engages the oscillator extension, holding the oscillator assembly in the lower position, with the ribbon below the printing line.

Functions

The operations of functions is accomplished through the medium of function levers. When the printing bail is in its rear or normal position, the function lever bail, which is attached to the printing bail, holds the function levers away from the vanes. As the printing bail moves forward, the function lever bail roller will move down off the high portions of the function lever rear arms, permitting the function lever springs to pull their respective levers against the vanes. The forward arms of the function levers are notched so that when a function combination is set up on the vanes the selected function lever will move forward farther than the other function levers (Fig. 15).

When in the selected position, the carriage return, line feed, figures, letters, bell and motor stop function levers will be in the path of one of the blocking extensions on the function lever bail (Fig. 15). This will prevent the printing bail from moving forward

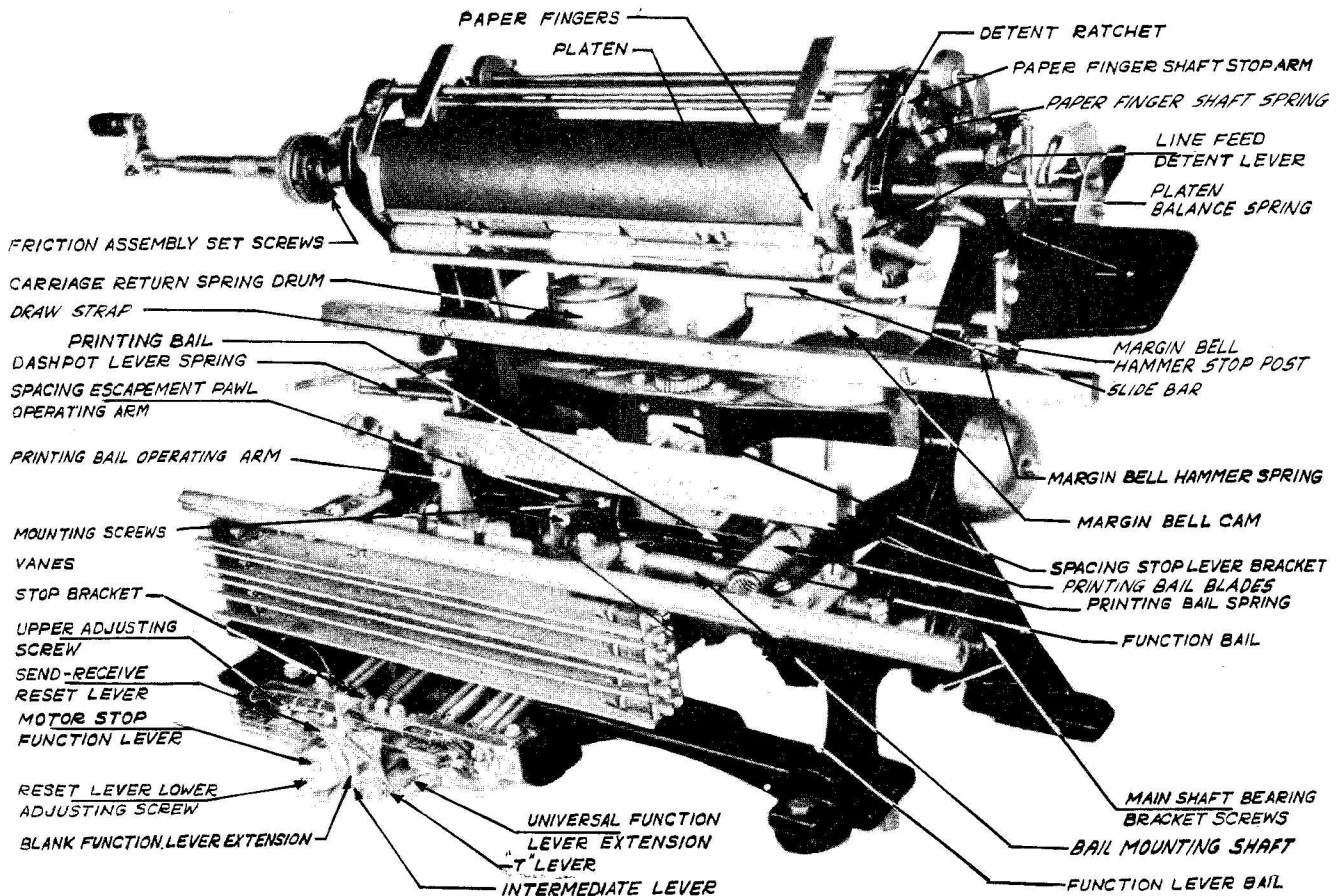

FRONT VIEW - TYPING UNIT
ILLUSTRATION 9

far enough to allow the typebar carriage to space. However, when the locking, universal, space or blank function lever is selected, the function lever bail will not be blocked inasmuch as their operation depends upon a complete movement of the printing bail.

The function bail, mounted on the bail mounting shaft, is used to operate some of the functions and is actuated by the function bail cam (Fig. 15). The function bail spring holds the function bail cam roller against the cam at all times. After the printing bail and the function lever bail move forward sufficiently far to release the function levers, the function bail roller starts to ride up the high part of its cam. This moves the function bail blade toward the rear, engaging and operating any function pushbar that may have been moved in its path by a selected function lever. The function bail roller will then ride down to the low portion of the function bail cam, the

bail blade returning to its forward position in readiness for the next function.

Carriage Return

When the carriage return function lever (second from the right) moves into engagement with the vanes, the function lever extension moves the carriage return latch bar upward out of engagement with its latch. This releases the carriage return operating lever, which actuated by its spring moves the carriage return clutch fork upward, disengaging the upper carriage return clutch member from the lower member. The spacing shaft is then free to turn in its sleeve so that the typebar carriage may be pulled back to its extreme left-hand position by the carriage return spring (within the carriage return drum) through the medium of the draw strap (Illus. 9). The notch on the reset bar will then be engaged by the function bail and moved to the rear. As the reset bar

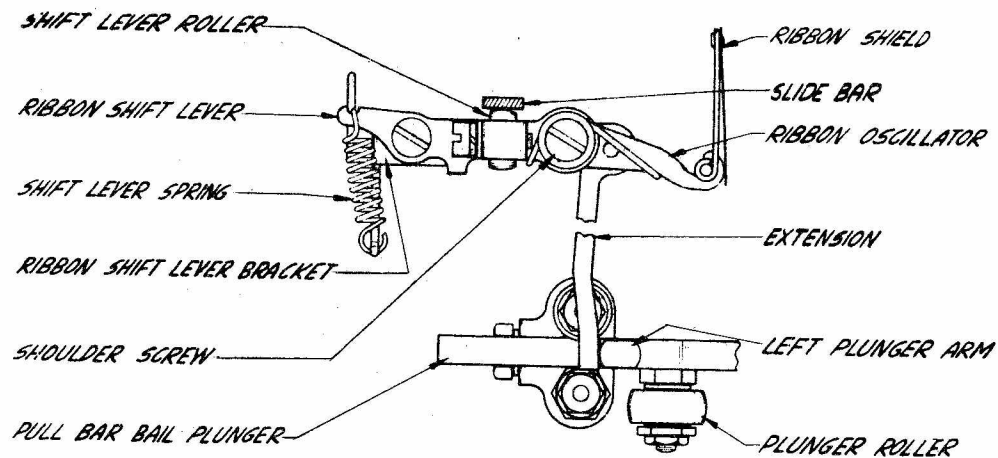

(SEE ILLUSTRATION 7)

Fig. 14

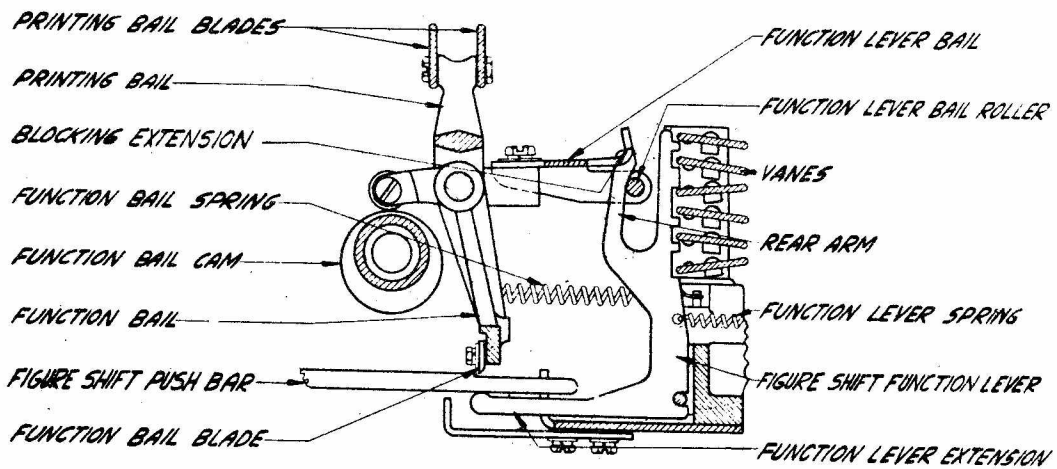

(SEE ILLUSTRATION 9)

Fig. 15

and the carriage return latch bar are both pivoted on the same screw the latch bar will be reset into engagement with its latch (Fig. 16). In the meantime the function lever bail will have been returned to its upper position and the carriage return function lever extension will have been moved down below the carriage return latch bar.

During the time that the carriage return operating lever was being operated by its spring, the lock bar was moved through a series of levers until its notch engaged with the lock bar latch (Fig. 16). This held the carriage return clutch members disengaged so as to insure a complete return of the carriage.

One end of the dashpot lever is attached to the dashpot plunger and the other end projects into the path of the typebar carriage. Just before the typebar carriage has returned to the beginning of the line, the left-hand margin adjusting screw (attached to the carriage) strikes the end of the dashpot lever driving the plunger into the dashpot air chamber absorbing the shock (Illus. 2).

When the typebar carriage returns to the beginning of the line, the dashpot lever strikes against the lower end of the lock bar latch, releasing the lock bar and carriage return clutch fork which in turn permits the carriage return clutches to engage.

The carriage return lock bar extends beyond its latch so that it may be operated manually.

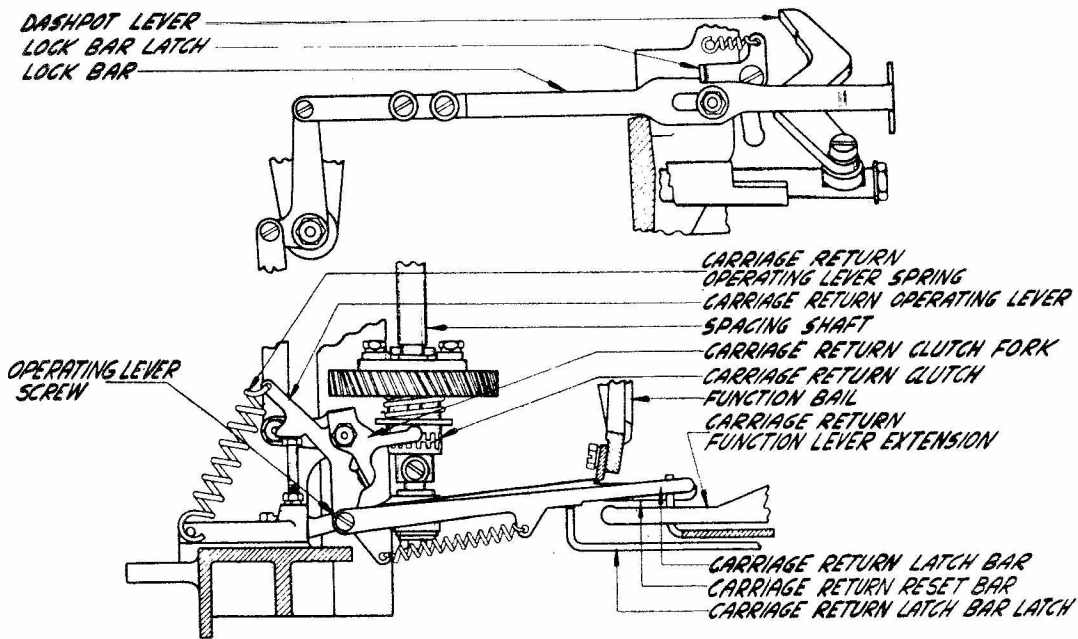

(SEE ILLUSTRATION 8.)

Fig. 16

Figure Shift and Letter Shift

The figure shift function lever, third from the right, when selected will move the figure shift push bar up to bring its notch into the path of the function bail (Fig. 15). This push bar when moved by the function bail will turn the right end of the shift link, to which it is connected, toward the rear of the printer and the left end of the link toward the front of the printer (Fig. 17 & Illus. 8). The shift lever which is engaged in the left end of the link is thus moved so as to pull the rear end of the platen assembly downward through the medium of the shift vertical link. The platen roll will be brought to its upper or shifted position.

The letters push bar is connected to the left-hand side of the shift link. When the letters push bar is operated by the function bail the action on the platen assembly will be reversed, bringing the platen down to the letters position.

The shift detent is provided to hold the platen assembly firmly in either the shifted or letters position.

Sixth Vane

The lower end of the spring attached to the sixth vane fits into the notch in the forward end of the letters push bar (Fig. 22). When the platen is in the figures position,

the letters push bar is in its forward position and the rear edge of the sixth vane is moved down. When the platen is in the letters position the rear edge of the sixth vane will be in its upper position. When the letter "S" or "M" is selected and the platen is in the letters position the bell and motor stop function levers will be inoperative because the sixth vane prevents their selection. With the platen in the figures position the sixth vane will not prevent the selection of the bell or motor stop function (See "Motor Stop Function" and "Signal Bell Function").

Note: Printers not equipped with mechanical motor control have period on the upper case of "M" and the motor stop function lever is omitted. Some printers are arranged to ring the signal bell on the upper case "J" or on the "Blank" in which cases the bell function levers are designed to be selected on these combinations. The sixth vane however is not used in connection with the signal bell function when the bell is made to ring on the "Blank" combination, as the platen may be in either the "Figures" or "Letters" position.

Spacing Function

Spacing other than that accompanied by printing (such as spacing between words, etc.)

is accomplished in the same manner as that described under "Spacing" except that there is no pullbar to be selected.

Unshift on Space Function

If desired the printer may be arranged to shift the platen to the letters position on both the space and letters combinations. This is accomplished by means of the space function lever.

When the unshift on space feature is not required the unshift on space cutout lever is moved into engagement with the space function lever making it inoperative. If the unshift on space cutout lever is moved out of engagement with the space function lever the space function lever extension will move upward on a "Space" combination and raise the letters shift push bar into the path of the function bail (Figs. 18 and 23). The platen will then be shifted to its "Letters" position as previously described under "Figure Shift and Letter Shift."

Signal Bell Function

When the bell combination is received the bell function lever, fourth from the right, will be selected. The extension on this lever will raise the bell latch bar out of engagement with the bell latch bar latch. This releases the bell operating lever so that its

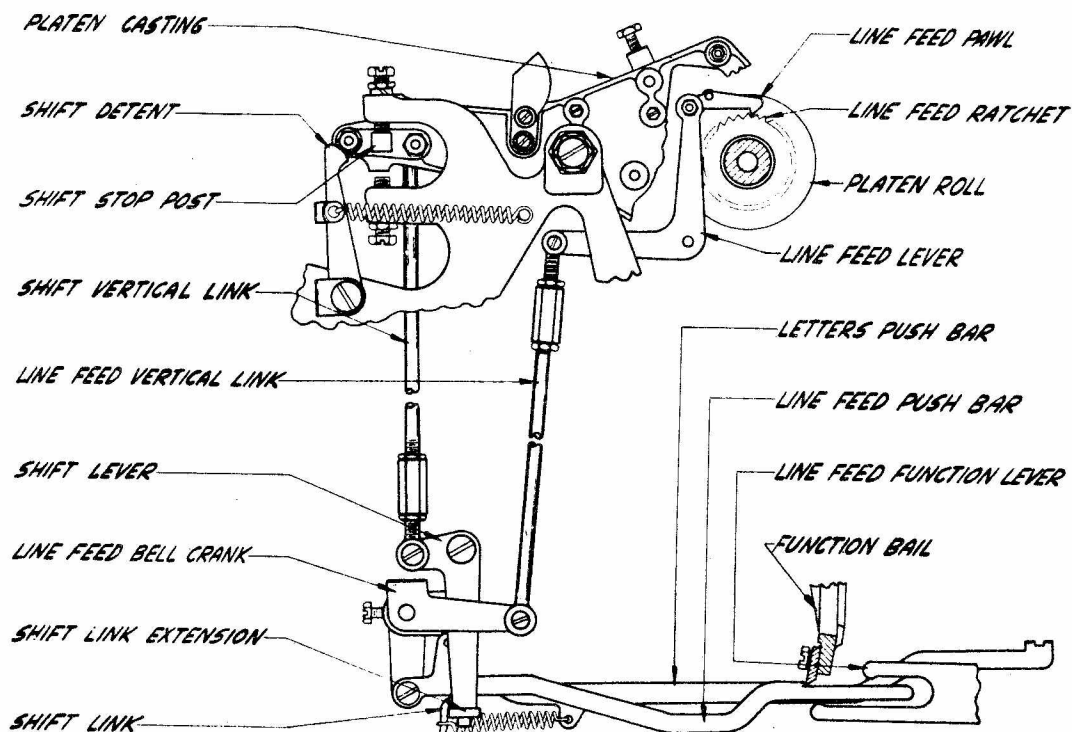

(SEE ILLUSTRATION B)

Fig. 17

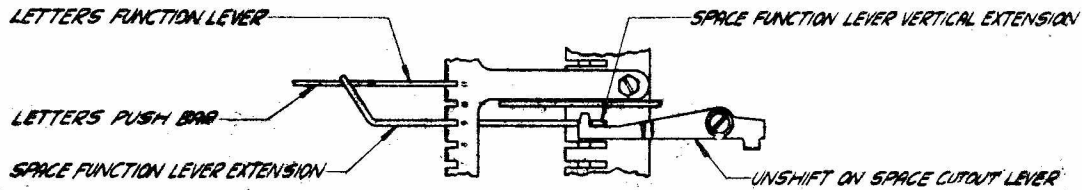

Fig. 18

spring may in turn rotate it, permitting the lever to strike the bell hammer arm extension throwing the bell hammer against the signal bell (Fig. 19). The notch of the bell reset bar being in the path of the function bail blade will reset the bell latch bar when the function bail moves to the rear. The bell reset bar and the bell latch bar move together, because they are both pivoted on the bell operating lever screw.

Line Feed Function

When the line feed function lever, ninth from the right, is selected its lower extension raises the line feed push bar into the path of the function bail blade (Fig. 17). When the bail moves toward the rear of the printer the line feed push bar rotates the line feed bell crank, pulling the line feed vertical link downward. This will operate the line feed lever which in turn will move the line feed pawl into engagement with the line

feed ratchet and rotate the platen one line space. When the line feed function lever is returned to its normal position by the function lever bail the upper function lever extension moves the line feed push bar down below the path of the function bail and holds it there until a line feed is again selected.

After each line feed operation the detent roller locates itself between two teeth on the ratchet thus holding the platen firmly in position during each line of printing (Illus. 9). The detent ratchet is attached to the right-hand end of the platen.

The single-double line feed lever in its lower position will allow the line feed pawl to engage two teeth thereby causing the platen to rotate a double line space (Illus. 2). When the single-double line feed lever is in its upper position the line feed pawl will be permitted to engage and operate only one tooth on the line feed ratchet which will cause the platen to rotate a single line space.

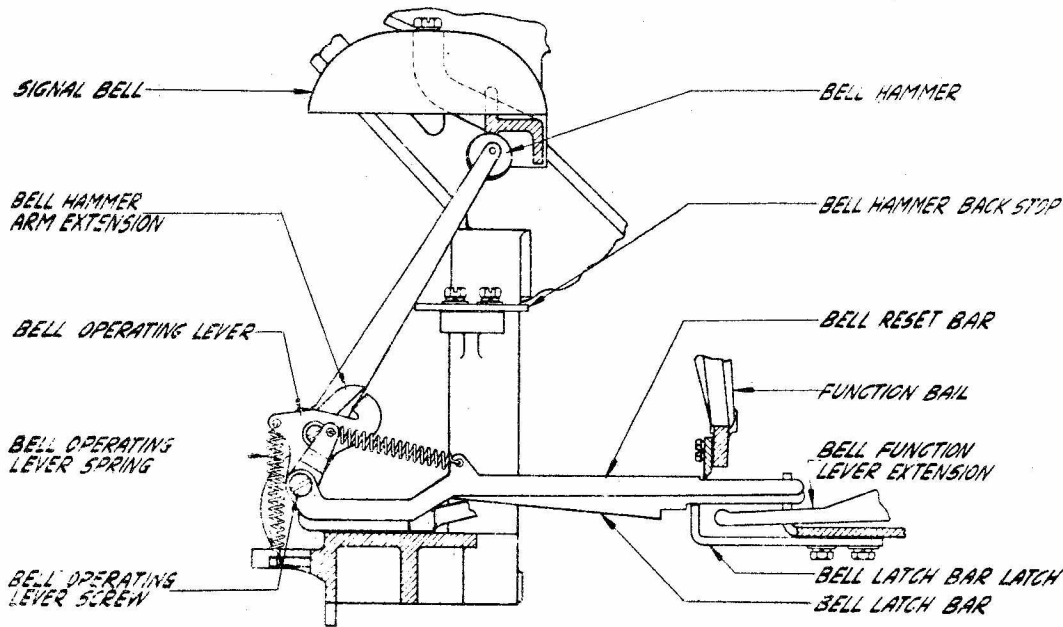

(SEE ILLUSTRATION B.)

Fig. 19

In order to facilitate paper feeding the paper straightener rod and a series of platen pressure rollers are provided (Fig. 9). The paper straightener rod is used to guide the paper as it is unwound from the roll. It is also used as a slack rod to prevent the paper from tearing. The pressure rollers hold the paper firmly against the platen to prevent slippage while line feeding.

Some printers are arranged to feed printed forms. The platen rolls on these printers are equipped with sprockets which mesh with holes perforated in the left and right-hand margins of the paper.

Keyboard Locking Mechanism

The following description does not pertain to printers arranged to operate the bell on blank signal combinations. However on printers of this type the keyboard locking mechanism may be operated manually.

When the period key of a keyboard is depressed twice, or the line is opened for a time interval equivalent to at least two revolutions of the keyboard cam shaft the keyboard control contacts will be caused to close, short-circuiting the keyboard transmission (Fig. 20). When the keyboard control contacts are closed, the sending-receiving handle will move to its lower position. All keyboards on the circuit will now be locked out until the sending-receiving handle is manually restored to its upper position.

The universal function lever (fifth from the right) moves with each operation of the printer and its extension is positioned above the right arm of the "T" lever (Fig. 20). With each movement of the universal function lever the right arm of the "T" lever will be pushed downward and the top of the "T" lever and the pivot of the intermediate lever will be moved to the right. This will keep the lower end of the intermediate lever out of the path of the blank function lever extension.

When the blank function lever (sixth from the right) is selected its extension moves downward at about the same time as the universal function lever and because the spring on the blank function lever is considerably stronger than that on the universal function lever the left of the "T" lever will be moved downward. The upper part of the "T" lever and the pivot of the intermediate lever will, therefore, be moved to the left, allowing the lower end of the intermediate lever to move against the side of the blank lever extension when the blank lever is in its lower position. When the blank lever extension moves upward at the end of the operating cycle it will permit the lower end of the intermediate lever to swing beneath the blank function lever (Fig. 21). If another blank selection is now made the intermediate lever will be pulled downward

moving the reset lever against the operating lever which will release the operating pawl. The spring on the operating pawl will move its extension against the contact springs which will close the keyboard control contacts and move the sending-receiving handle to the lower position.

If only one blank signal is received followed by a space or character the keyboard will not be locked out because the intermediate lever will be moved out of the path of the blank function lever extension by the universal lever extension. Thus it can be seen that two consecutive blank combinations will have to be received before the keyboard will be locked out. It is to be noted that the period combination is the same as "Blank" and the code combination is all spacing or no current.

At the same time the operating pawl closes the keyboard control contacts, it is also opening a second pair of contacts. These contacts are used when it is desired to control a tape transmitting distributor.

Motor Stop Function

This description pertains only to machines equipped with mechanical motor control:

When the "H" on the sending keyboard is depressed either following the depression of the "Figures" key or at any time the platens are in the figures position the motors on all machines connected in the circuit will be automatically stopped.

When the motor stop function lever (tenth from the right) is selected its lower rear extension will raise the lower part of the motor stop lever moving the inner motor stop pawl so that it latches at the thick portion of the motor stop pawl latch on the armature extension (Fig. 22). At the same time the front extension of the motor stop function lever closes the left-hand motor contacts. Simultaneously with the closing of the left-hand contacts, the motor stop contact lever rear extension is moved up by the extension of the motor stop lever and the front extension moves down against the tension of its spring. This allows the right-hand motor stop contacts to open. Both pairs of contacts are wired in multiple so that the motor will not stop until the motor stop function lever is restored to its normal position at which time its front extension will move upward permitting the left-hand contacts to open.

The purpose of the left-hand contacts is to hold the motor circuit closed until the receiving cam sleeve comes to rest. This will insure the disengagement of the main shaft clutch before the motor stops (Fig. 23).

In order to start the motors again, the line must be opened for a short interval by

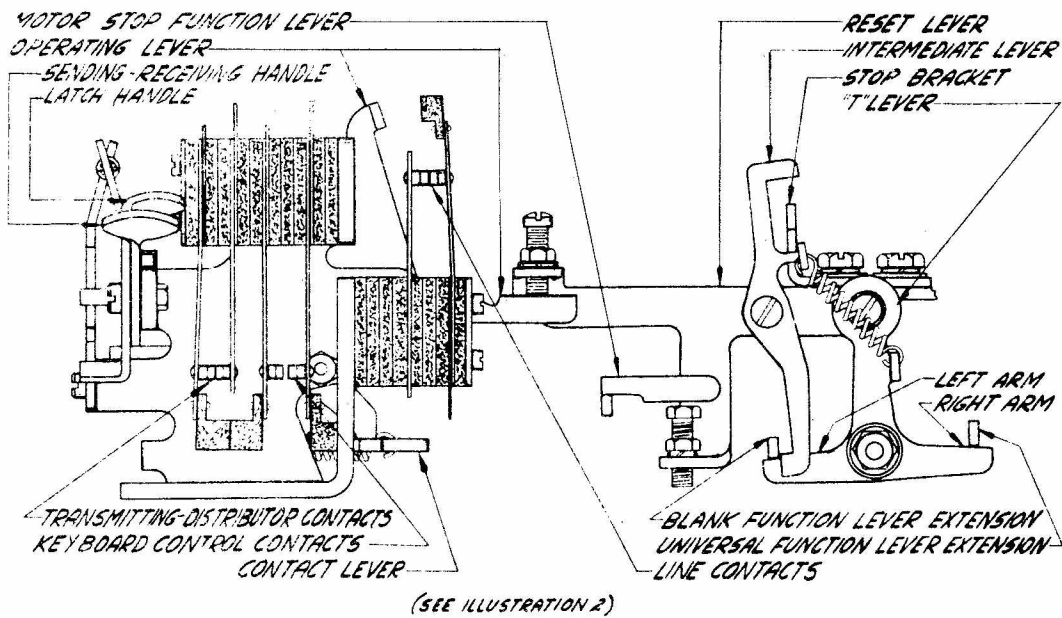

Fig. 20

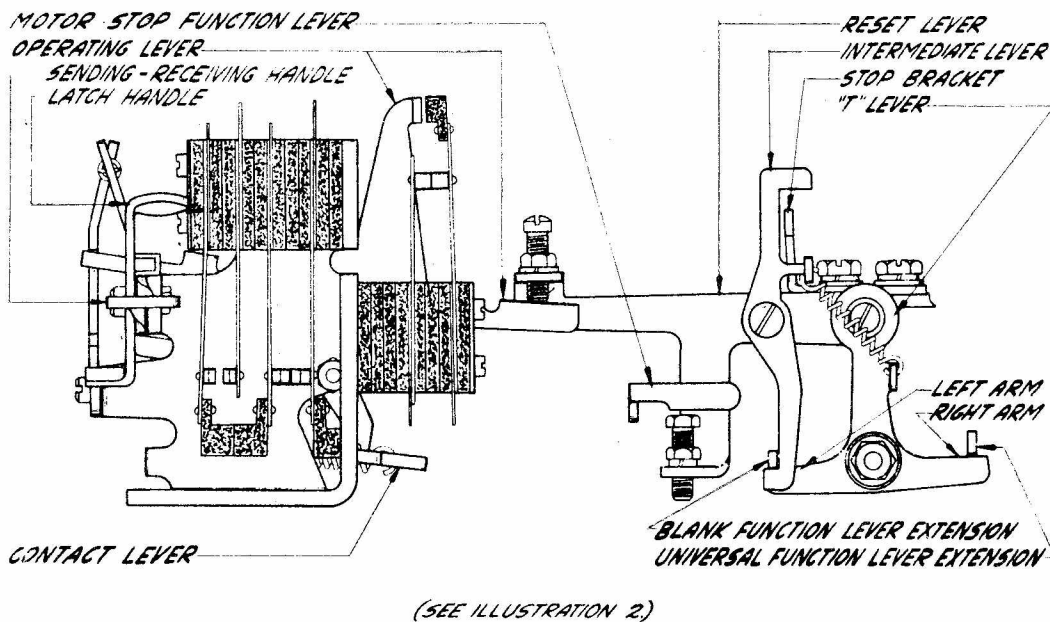

Fig. 21

depressing the latch handle (above and to the rear of the sending-receiving handle). This will move the upper operating lever extension against the line contact insulator which opens the line (Fig. 20). The opening of the line allows the selector armature extension to be moved downward by the armature spring. After the upper end of the motor stop lever has moved forward a slight amount it is again stopped by the outer stop pawl catching on the

cut away portion of the motor stop pawl latch (Fig. 22).

When the line is closed again the armature will move to its operated position which will disengage the armature extension latch from the outer motor stop pawl, permitting the motor stop lever to return to its normal position. The extension on the lower portion of the motor stop lever which has been holding

the motor stop contact lever away from the right-hand motor stop contacts will now permit the spring to move the front extension of the motor stop lever upwards, closing the motor stop contacts.

It should be noted that when the motor control function is operated the keyboard control contacts are closed, locking out the keyboard transmission. This is accomplished by the forward end of the motor stop function lever moving downward against the lower screw on the reset lever. The reset lever in turn moves the contact operating lever as previously described in "Keyboard Locking Function."

armature extension latch. This is accomplished by means of the motor stop release lever. When the locking lever is in an indent it comes into contact with the release lever stud. This holds the eccentric at the upper end of the motor stop release lever against the lower end of the outer motor stop pawl preventing the pawl from latching with the motor stop pawl latch. Thus the motor stop will not be permitted to function and the motor will continue to rotate.

MOTOR SPEED CONTROL

In order to maintain the transmitting and receiving stations at the proper speed the

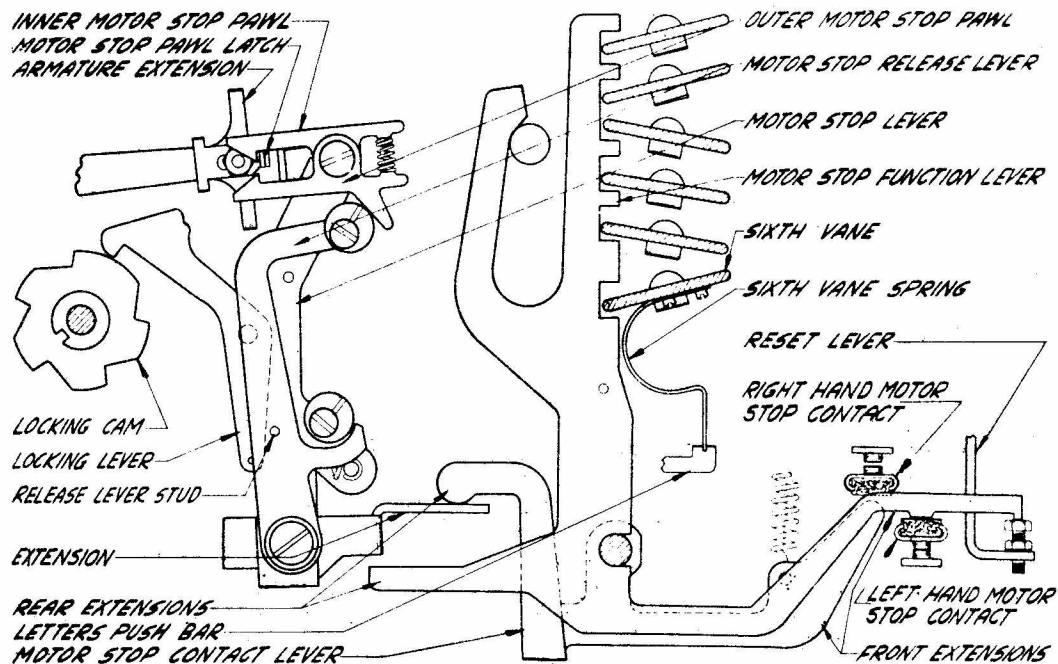

(SEE ILLUSTRATION 2)

Fig. 22

The motor stop release lever is provided to eliminate the possibility of the selector cam sleeve coming to rest with the armature locking lever in a low part of its cam (Fig. 22). For example; immediately after the "Figures" and "M" keys have been depressed and before the motor has stopped, should the line accidentally open releasing the start magnet armature, the selector cam sleeve would revolve beyond the stopping point and it is possible that the armature locking lever might come to rest in an indent in its cam. It can be seen that if the cam were to stop in this position, the armature extension would not be free to respond to the next open line interval thus making it impossible to operate the mechanical motor control. In order to avoid a condition of this kind a mechanism is arranged so that when the locking lever is in an indent in the locking cam, the motor stop release lever will not be permitted to latch onto the

driving motor is equipped with a governor attached to one end of the motor shaft (Fig. 24).

The governor contact arm consists of a bent strip of metal with a contact mounted on one end and fastened by a flat spring at the other end. The contact arm spring holds this contact against a companion contact until the centrifugal force of the contact arm overcomes the tension of the spring. When the contacts open, a resistance is connected into the motor circuit which tends to reduce the speed of the motor. The closing and opening of the contacts holds the motor speed constant to the value of the tension at which the spring is set. The spring tension is adjusted by turning the speed adjusting wheel which extends through the cover of the governor.

Some machines are equipped with synchronous motors which maintain a constant speed without the aid of a governor.

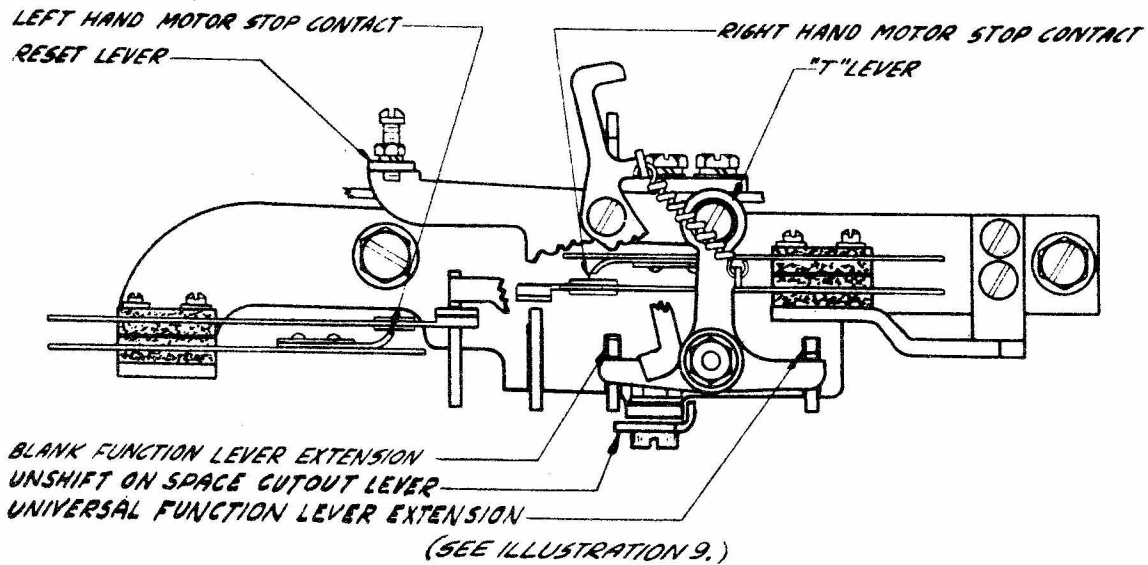

Fig. 23

On the right rear corner of the motor base, mounted on a bracket, is a lamp with a switch, which provides illumination for the speed target when a governor equipped motor is used.

The transmission of the start impulse, which is a spacing impulse, starts the selector cam sleeve on the printer revolving. The speed of rotation is such that when the transmitting cam shaft has revolved far enough to

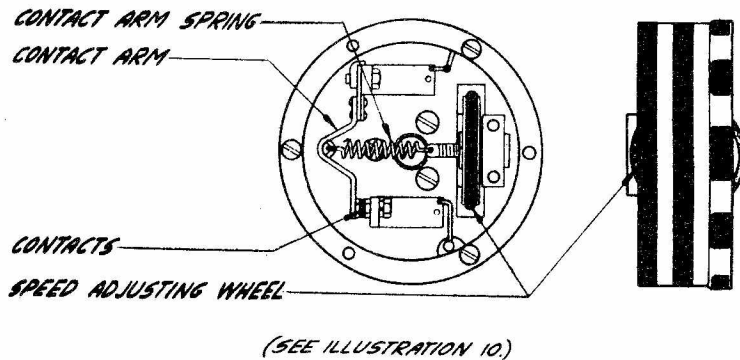

Fig. 24

next impulse is one-seventh greater than the distance between the position where the keyboard cam shaft can control the sending out of one impulse and the next impulse.

The reason that the selector cam sleeve is made to rotate one-seventh faster than the transmitting cam shaft is this: It is not possible to maintain several units at exactly the same speed. In a short time even a slight speed difference would cause the transmitting mechanism and receiving mechanism to get out of unison so that when the transmitting keyboard was sending out the first impulse of a character signal, the selector cam sleeve might be in a position to receive the second. This is avoided by arranging the selector cam sleeve to rotate faster than the transmitting keyboard which allows it to complete its revolution sooner than the transmitting distributor completes the corresponding one. In other words, if the transmitting keyboard cam shaft has to travel $48-1/2^{\circ}$ to get from the position where it sends out the first impulse to the position where it sends out the second, the selector cam sleeve must travel $55-1/2^{\circ}$ to get from the position where it can receive the first impulse to the position where it can receive the second, but as the selector cam sleeve travels one-seventh faster, it will

reach this second position at the same time the transmitting keyboard reaches its second position.

When the selector cam sleeve has completed a revolution it comes to a stop until the transmitting keyboard again sends out a "Start" impulse. Now, if the speed of the selector cam sleeve is slightly faster than its proper speed, the only effect will be that it will remain at rest slightly longer. If its speed is slightly slower than the proper speed, it will remain at rest just that much less time. Of course there will be a slight error in the position of the selector cam sleeve in the various positions but the mechanism is so constructed to provide for this and due to the fact that the selector cam sleeve starts each revolution in unison with the transmitting cam shaft this error does not become any greater.

ORIENTATION

In order to properly operate the selector mechanism it is necessary to place the starting point of the selector cam sleeve in the most favorable position. This is accomplished by means of the range finding mechanism which is used to orient or take a range.

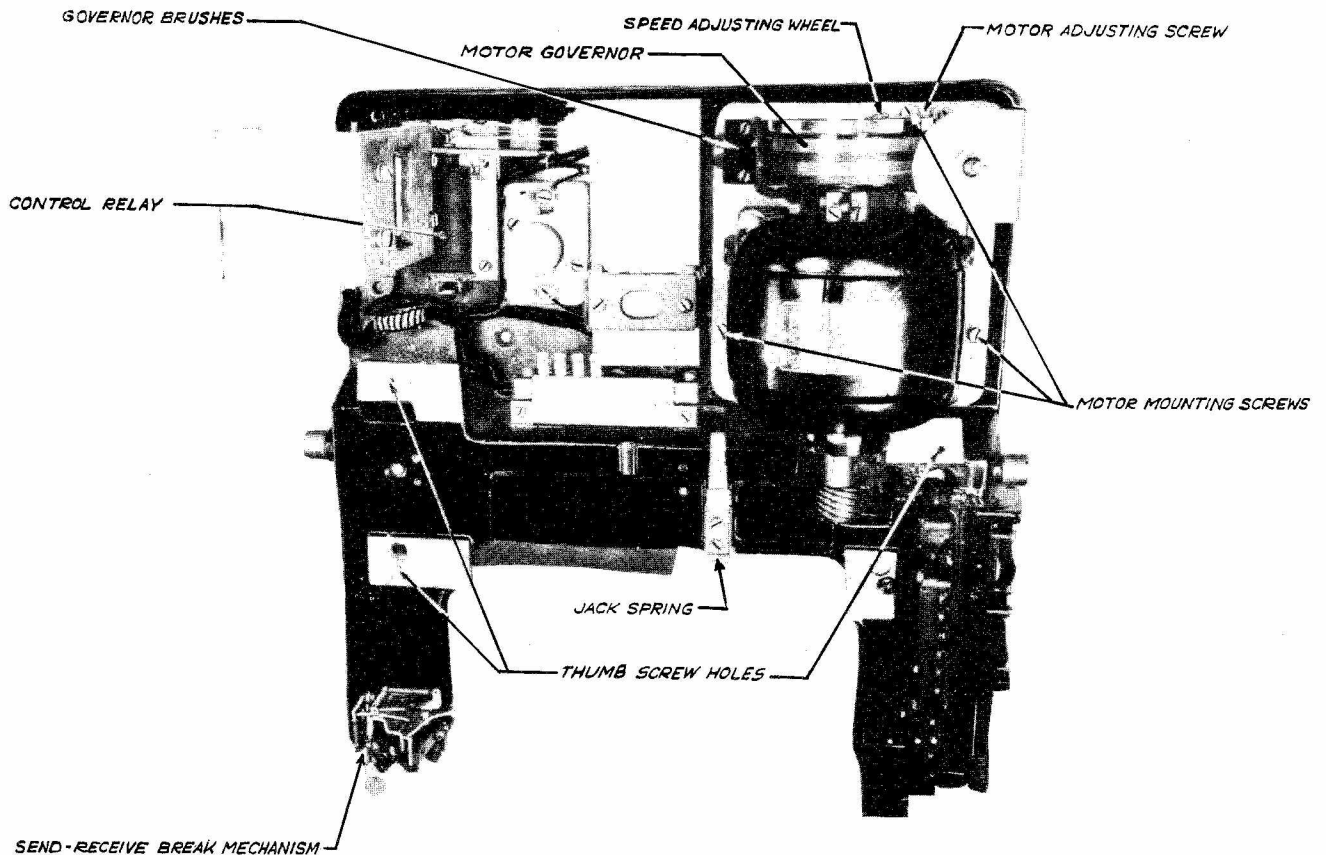

TOP VIEW-BASE WITH MOTOR UNIT
ILLUSTRATION 10.

Mounted on the stop lever plate (which is a part of the range finding mechanism) are the stop pawl latch and the stop pawl which may be rotated thereby varying the relation between the start of the selector cam sleeve and the time the selector cams operate the selector levers. A graduated scale indicates the setting of the stop mechanism and the clamping plate screw holds it in place after having been set (Illus. 5 & Fig. 4).

LINE-TEST KEY

Mounted on certain coded keyboards (to the left of the transmitting contact assembly) is the "Line-Test" Key (Illus. 3). It is provided for the purpose of testing the machine without interrupting the line circuit.

When the knob of the "Line-Test" Key is pulled out, the selector magnets and keyboard contacts are disconnected from the line and a local circuit is established.

LINE RELAY

A line relay base is provided on 15A and 15B bases (mounted on a bracket located to the rear of the typing unit) so that a line relay may be used.

The wiring is arranged so that either the line relay or the selector magnets may be connected in the line circuit. In the former case, the contacts of the line relay repeat the signals to the selector magnets whereas in the latter the selector magnets are connected directly in the line.