



This is a digital copy of a book that was preserved for generations on library shelves before it was carefully scanned by Google as part of a project to make the world's books discoverable online.

It has survived long enough for the copyright to expire and the book to enter the public domain. A public domain book is one that was never subject to copyright or whose legal copyright term has expired. Whether a book is in the public domain may vary country to country. Public domain books are our gateways to the past, representing a wealth of history, culture and knowledge that's often difficult to discover.

Marks, notations and other marginalia present in the original volume will appear in this file - a reminder of this book's long journey from the publisher to a library and finally to you.

Usage guidelines

Google is proud to partner with libraries to digitize public domain materials and make them widely accessible. Public domain books belong to the public and we are merely their custodians. Nevertheless, this work is expensive, so in order to keep providing this resource, we have taken steps to prevent abuse by commercial parties, including placing technical restrictions on automated querying.

We also ask that you:

- + *Make non-commercial use of the files* We designed Google Book Search for use by individuals, and we request that you use these files for personal, non-commercial purposes.
- + *Refrain from automated querying* Do not send automated queries of any sort to Google's system: If you are conducting research on machine translation, optical character recognition or other areas where access to a large amount of text is helpful, please contact us. We encourage the use of public domain materials for these purposes and may be able to help.
- + *Maintain attribution* The Google "watermark" you see on each file is essential for informing people about this project and helping them find additional materials through Google Book Search. Please do not remove it.
- + *Keep it legal* Whatever your use, remember that you are responsible for ensuring that what you are doing is legal. Do not assume that just because we believe a book is in the public domain for users in the United States, that the work is also in the public domain for users in other countries. Whether a book is still in copyright varies from country to country, and we can't offer guidance on whether any specific use of any specific book is allowed. Please do not assume that a book's appearance in Google Book Search means it can be used in any manner anywhere in the world. Copyright infringement liability can be quite severe.

About Google Book Search

Google's mission is to organize the world's information and to make it universally accessible and useful. Google Book Search helps readers discover the world's books while helping authors and publishers reach new audiences. You can search through the full text of this book on the web at <http://books.google.com/>

D 101.11:
1-680

TM 11-680

T. O. 16-1-117

DEPARTMENT OF THE ARMY TECHNICAL MANUAL

UNIVERSITY OF VIRGINIA
ALDERMAN LIBRARY

DEC 10 1991

GOVERNMENT DOCUMENTS

TELETYPEWRITER CIRCUITS AND EQUIPMENT (FUNDAMENTALS)

DEPARTMENT OF THE ARMY • OCTOBER 1947

Digitized by Google

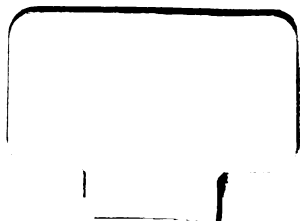

DEPARTMENT OF THE ARMY TECHNICAL MANUAL
TM 11-680

This manual supersedes TM 11-456, 15 July 1942, including C1, 1 April 1944; and so much of TM 11-353, 2 July 1911, as pertains to equipment covered in this manual.

TELETYPEWRITER
CIRCUITS
AND EQUIPMENT
(FUNDAMENTALS)

DEPARTMENT OF THE ARMY

OCTOBER 1947

United States Government Printing Office
Washington: 1947

DEPARTMENT OF THE ARMY
Washington 25, D. C., 15 October 1947

TM 11-680, Teletypewriter Circuits and Equipment (Fundamentals), is published for the information and guidance of all concerned.

[AG 300.7 (4 Dec 46)]

BY ORDER OF THE SECRETARY OF THE ARMY:

OFFICIAL:

EDWARD F. WITSELL
Major General
The Adjutant General

DWIGHT D. EISENHOWER
Chief of Staff, United States Army

DISTRIBUTION:

AF (10); AGF (5); T (5); Dept (2); Base Comd (2); AF Maj Comd (15); Arm & Sv Bd (1); AGF Bds (ca sec) (1); Tech Sv (2); AMA (10); Class III Instls (3); Dep 11 (5) except Sacramento, Holabird (15); A (ZI) (20), (Oversea) (5); CHQ (2); Two (2) copies of the following T/O&E; 11-7; 11-15; 11-57; 11-95; 11-107; 11-127; 11-537T; 11-557T; 11-587; 11-597.

For explanation of distribution formula, see TM 38-405.

CONTENTS

	<i>Paragraphs</i>	<i>Page</i>
CHAPTER 1. INTRODUCTION.		
<i>Section I.</i> Transmission principles	1-8	1
<i>II.</i> Teletypewriter signals and line characteristics	9-12	9
<i>III.</i> Basic teletypewriter circuits	13-18	15
<i>IV.</i> General functions of repeaters and switchboards	19-24	21
CHAPTER 2. TELETYPEWRITER EQUIPMENT FEATURES.		
<i>Section I.</i> Equipment connections	25-36	29
<i>II.</i> Field teletypewriter equipment	37-65	44
<i>III.</i> Telegraph central office equipment	66-82	72
<i>IV.</i> Maintenance procedures for Switchboard BD-100	83-98	89
<i>V.</i> Interoperation and connection of teletypewriter equipment in conjunction with d-c repeaters..	99-107	107
<i>VI.</i> Connection of Switchboard BD-100 to commercial teletypewriter systems.....	108-111	121
CHAPTER 3. TEST SETS AND RECTIFIERS.		
<i>Section I.</i> Use of test sets	112-126	128
<i>II.</i> Rectifiers	127-137	145
CHAPTER 4. RADIO TELETYPE EQUIPMENT.		
<i>Section I.</i> Teletypewriters TT-10/FG and AN/TGC-3	138-141	164
<i>II.</i> Teletypewriter Set AN/TGC-1	142-146	186
CHAPTER 5. RECORDS, PROCEDURES FOR ADVERSE CLIMATIC CONDITIONS, AND DESTRUCTION PROCEDURES.		
<i>Section I.</i> Tactical diagrams and station records	147-149	200
<i>II.</i> Tropical and arctic maintenance of teletypewriter equipment.....	150-156	207
<i>III.</i> Destruction of teletypewriter equipment in combat zone	157-160	212
APPENDIX. GLOSSARY OF TERMS USED IN TELETYPEWRITER MAINTENANCE.....		216
INDEX		219

FOREWORD

This manual is a basic textbook covering the fundamentals of the circuits and equipment used in United States Army teletypewriter land-line and radio networks throughout the world. It may be used as a textbook or as a reference manual. It is assumed that students and others using this manual are familiar with basic electrical theory and the ordinary use and operation of simple parts such as gears, bearings, levers, rollers, cams, etc.

The material in this manual is used in training teletypewriter mechanics, SSN 239. Presented in a single manual is all of the text required to familiarize the student mechanic with the necessary broad practical reasoning of how the many different circuits and equipments function. The student is thoroughly prepared to develop his skill with a maximum efficiency when he proceeds to specialize in the installation and maintenance of the various teletypewriter equipments and refers to the technical manual furnished with each equipment for detailed field instructions.

The material in this manual has been arranged for a course of approximately 262 hours duration. In specific cases this time allotment may vary according to the number of different equipments to be covered, the time available, and other modifying factors.

CHAPTER 1

INTRODUCTION

Section I. TRANSMISSION PRINCIPLES

1. General

a. In teletypewriter transmission the chief concern is reproduction of a message at the receiving end without error and interference to other services. Teletypewriter transmission differs from telephone transmission in that intelligence is conveyed from a sending point to one or more receiving points by means of a signal code over direct-current (d-c) systems, over carrier systems, or over radio channels.

b. Direct-current systems of transmission are used extensively for short distances. The distance over which satisfactory operation may be expected depends for the most part upon the characteristics of the circuit. Such systems are used with open wire, cable, and various types of insulated field wire. In military operations, d-c operation is used on teletypewriter circuits between corps headquarters and lower echelons, and between all other headquarters where the lines are of comparatively short distances and where comparatively few circuits are needed.

c. Carrier transmission of teletypewriter signals is accomplished by those systems which make use of either voice-frequency or high-frequency alternating current to carry signals over a signal line. After the signals are so carried, the alternating current is converted into direct current for operation of the teletypewriter equipment. How this conversion of current is accomplished is explained in later sections of this technical manual. At present at least 60 percent of all commercial teletypewriter circuit mileage is established on carrier systems which use both open wire and cable plant facilities. In military transmission, carrier is extensively used, especially over long distances and also when large groups of circuits are required. Figure 3 illustrates the principle of carrier operation.

d. In addition to the teletypewriter transmission systems described in *b* and *c* above, teletypewriter transmission by means of radio channels has come

into wide use. This type of transmission is of great value between points that are either inaccessible or difficult to reach by wire facilities, such as points at opposite sides of large bodies of water, over long distances of jungle areas, or between two or more mountain peaks. Radio teletypewriter systems are often used over long distances in theater operations. By the use of certain available radioteletype equipment, radio channel teletypewriter transmission is possible over distances of a few miles to several thousand miles. More detailed description of this type of transmission is given later in this manual.

2. Theory of d-c Systems

a. GENERAL. D-c systems of transmission fall into two fundamental classes: Neutral and polar operation. All other systems of d-c transmission, no matter how complex, are basically combinations of neutral or polar principles.

b. NEUTRAL OPERATION. Neutral or *open and close* operation makes use of a certain flow of current over the line to operate the receiving mechanism to *marking* or operated position, and zero current over the line for *spacing* or unoperated position. In this type of operation a receiving relay may or may not be used, though the usual practice calls for a relay of a neutral type. Figure 1 shows a simple open and close or neutral telegraph circuit. When the sending key is closed, current flows through the windings of the sounder and overcomes the pull of the retractile spring and the sounder bar moves to its lower position. When the key is opened, no current flows through the sounder windings; the sounder bar, therefore, is pulled to its upper position by the retractile spring. To make the circuit suitable for two-way operation and to allow the sending operator to hear his own signals, a key and sounder are ordinarily provided at each end of the circuit.

c. POLAR OPERATION. Polar operation differs from neutral operation in that telegraph signals are formed by reversing the direction of current flow to a receiving polar relay instead of interrupting

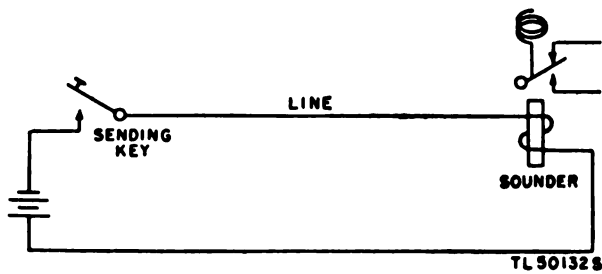

Figure 1. Simple one-way neutral circuit.

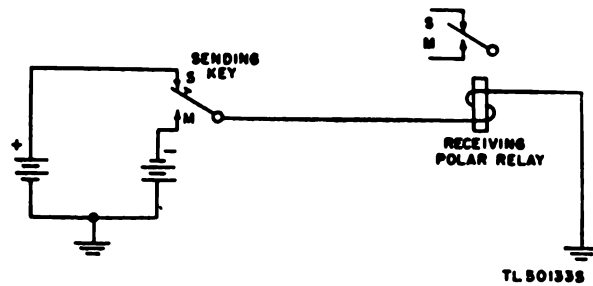

Figure 2. One-way polar circuit.

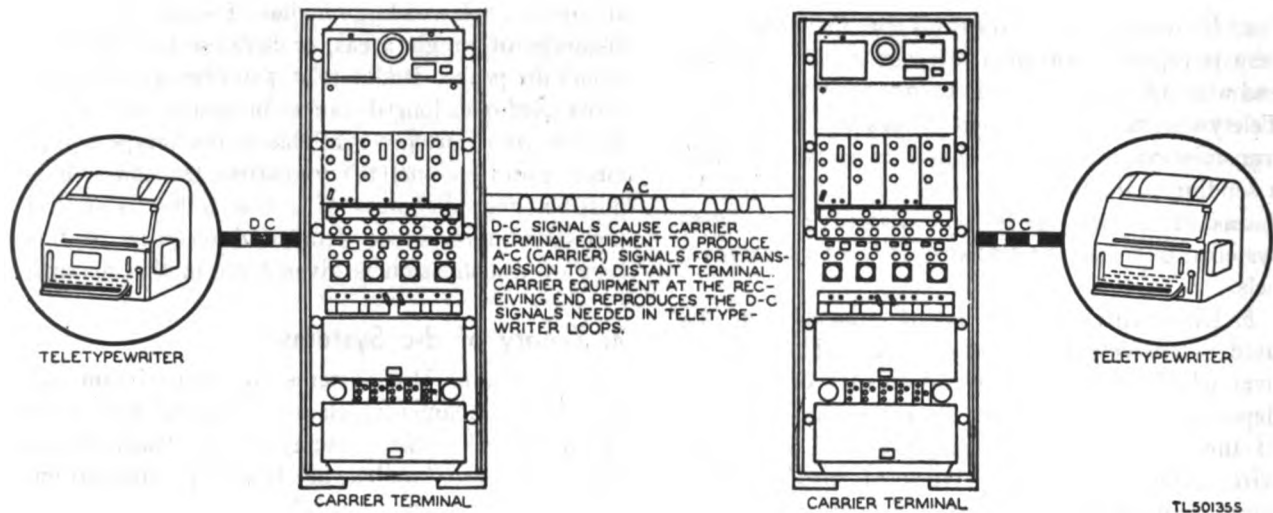

Figure 3. Principle of carrier operation.

the current flow. In other words, polar operation uses a flow of current of one polarity over the line to operate the receiving relay armature to the marking position, and a flow of current equal in value but opposite in direction to the marking current to operate the armature to the spacing position. Figure 2 shows the simplest form of polar telegraph circuit, namely a *one-way polar* circuit. The sending key is arranged so that equal and opposing current for marking and spacing flows through the receiving relay at the distant end of the line.

3. Grounds

a. GENERAL. The earth is often used as one side of an electrical circuit, thus eliminating the necessity of two wires for each circuit. A ground-return circuit is especially important in Army communications because telegraph equipment and teletypewriters are usually simplexed on existing telephone circuits in field installations and operate over ground returns. In the operation of ground-return

teletypewriter circuits, there is probably no one element of the entire system that can be given greater importance than the earth connection. This is so because the earth, considered by itself, has practically no resistance as an electrical conductor. For satisfactory operation of most wire communication circuits using a ground connection, the value of the ground resistance must be kept within prescribed limits. Proper protection of equipment and proper operation of the circuit and equipment depend upon getting a ground connection of sufficiently low resistance.

b. EFFECTS OF POOR GROUNDS. The range of operation for teletypewriter communication using ground-return circuits is dependent upon variable line conditions of which ground resistance is a part. Some circuit adjustments can usually be made to compensate for poor line conditions, but a high ground resistance will reduce the operating range. A poor ground contact is equivalent to high resistance in series with the circuit and may cause

serious difficulty in one or more of the following ways:

(1) Ground resistance may be so high that it will not be possible to obtain the required line current.

(2) Ground resistance may change considerably with wet and dry weather and necessitate additional line-ups. For example, if conditions are dry and grounds have high resistance when the circuit is first installed, then, when conditions become wet, resistance of the ground will probably disappear or at least materially decrease. The line current will then increase, causing distortion in the signal.

(3) If more than one circuit is operated between two points where high resistance ground conditions exist, the circuits will interfere with each other because common ground resistance will couple them together. In multi-circuit equipment using a common ground connection, such as teletypewriter switchboards or repeaters, severe cross-fire* results if ground resistance is too high.

c. HOW TO OBTAIN GOOD GROUNDS. Whenever it is possible, the ground connection for teletypewriter circuits should be obtained by a solid clamp contact with a cold water pipe or with some other metallic body which is buried and which has a large surface area in tight contact with the earth. If a ground clamp is not available, scrape a portion of the water pipe clean. Wind about 10 turns of clean wire around the scraped pipe, twist the wire ends tight, and tape the wires tightly. Use grounded metallic structures such as buried conduits or pipes whenever possible because they provide better conductivity through greater contact area. If using a water pipe on which a meter or cut-off device is attached, the ground connection should be made on the street or service-main side of the attachment. Where water pipes, or equivalent, are not available, use ground rods.

d. USE OF GROUND RODS. Ground rods, when issued with most tactical teletypewriter equipment (in most instances Ground Rods MX-148/G), if correctly placed and carefully driven, should in most instance give satisfactory ground-return operation. However, if high resistance is encountered when one ground rod is fully driven into the earth, use of ground rods in multiple or treatment of the soil will usually result in a lower resistance ground connection. Be sure to remove paint and grease from all ground rods before they are driven

*Cross-fire may be defined as foreign current impulses produced in teletypewriter circuits by the operation of other parallel teletypewriter circuits.

into the ground. Rust is not particularly important, but paint or grease is almost fatal to good conductivity.

(1) *Length of ground rod.* To be of value, the ground rod must be long enough to reach below the permanent moisture level of the earth, thus placing the lower end in contact with permanently wet earth below frost level. Care must be taken when a ground rod is driven to prevent side vibration of the free portion of the rod to make sure that the hole in the earth is not widened. The rod must fit tightly in the earth for best results. Additional length to a ground rod may materially increase the electrical conductivity of the ground-return circuit because the added depth will be nearer to, or deeper into, the permanent moisture level. Longer ground rods, by penetrating deeper into the permanent moisture level, have an advantage of maintaining resistance at a steadier value over a period of time. Dry and freezing conditions are not likely to affect ground resistance of circuits using long ground rods to the same extent as those using shorter rods. Moreover, long ground rods may reduce ground resistance enough to eliminate treatment of the soil. The curve in figure 4 indicates the effect on resistance of ground rods at various depths, calculated for uniform soil at all depths.

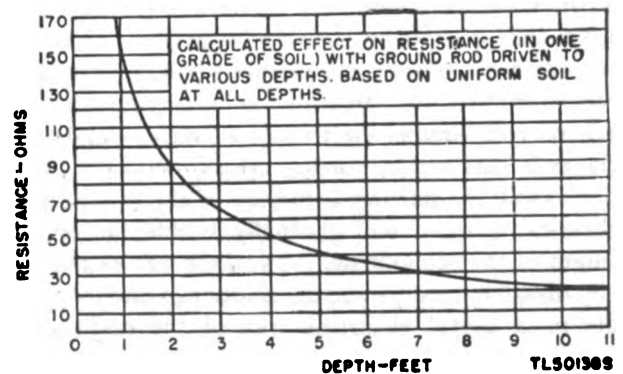

Figure 4. Resistance effect with ground rods at various depths.

(2) *Ground rod diameter.* Though it has been established that the soil surrounding a driven ground rod has a great effect on the resulting ground resistance and that the length of the rod is of major importance, it is also a fact that only a negligible effect on ground resistance can be caused by varying the diameter of the rod. The ground rod diameter need only be large enough to permit its being driven into the earth and removed without bending or splitting.

(3) *Soil conditions.* The qualities of soil which make it advantageous for grounding are the presence of moisture and the concentration of salts dissolved in this moisture. The following list arranges soil of various types in order of ascending specific resistances:

- Treated grounds Excellent.
- Wet soil Excellent.
- Clay or loam Very good.
- Wet sand Good.
- Dry sand Poor.
- Gravel and rock Unsatisfactory.

(4) *Soil treatment.* Soil treatment is recognized as an effective means of lowering the resistance of high-resistance ground installations. The success of soil treatment depends chiefly on the characteristics of the soil, chemical treatment used, method of applying the treatment, and its subsequent supervision in order to re-treat when it is advisable. Treatment of ground rod installations by as little as 5 pounds of ordinary table salt (sodium chloride), heavily watered and soaked into the earth, will often materially reduce high resistance and render the circuit satisfactory for operation. In general, the higher the resistance of the soil, the greater will be the percentage of improvement in electrical conductivity after treatment. Thus a ground resistance of 30 ohms may be reduced about 50 percent by treatment, whereas the same treatment may reduce a 1,000-ohm ground by possibly 90 percent. Crystals such as rock salt and not merely a salt solution are recommended for treating soil surrounding a ground rod. Greater electrical conductivity and efficiency is obtained by placing salt crystals at the top of the soil. By starting at the top of the soil, all the chemical solution will gradually trickle the entire length of the ground rod. As surface waters gradually dissolve the crystals, the solution is carried into the most useful electrical area of the earth surrounding the rod. Many gallons of solution are provided by a relatively small quantity of rock salt crystals. Figure 5 illustrates this method. When first installed, it is well to flood the ground installation with water; then water it as often as necessary thereafter. Usually satisfactory grounds are obtained if the following procedure is followed:

- (a) Select the lowest, dampest site in the vicinity. Clay or loamy soil is best.
- (b) Scoop out a hole about 6 inches deep in the selected location.
- (c) Drive a rod (free from paint or grease) in the hole until the top of the rod is approximately 3 inches below the surface.

(d) Clamp the lead wire securely to the ground rod. Saturate the earth around the rod with water, and fill in the hole with earth, covering the top of the rod. Keep the earth around the rod moist by frequent application of water.

(e) If satisfactory low ground resistance is not obtained with one rod, drive additional rods in parallel, using the above method. Do not have spacing between the adjacent rods less than 10 feet.

(f) If multiple ground rods in parallel fail to provide adequate low ground resistance, treat the soil around the rods. Dig a basin 3 feet in diameter and 1 foot deep around each rod. Mix a solution consisting of 5 pounds of salt and 5 gallons of water for each rod. Pour this solution into the basin and allow it to seep through the soil. In half an hour, or as soon as the solution has seeped through the soil, check connections and fill the basin with excavated soil, packing it in as solidly as possible.

(5) *Ground rods in multiple.* When the desired ground resistance cannot be obtained with a single ground rod, installing a second rod, in parallel with the first, will reduce resistance considerably. Additional ground rods, also connected in parallel, will

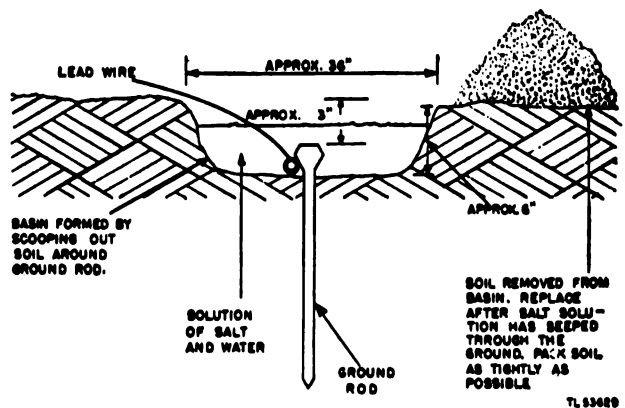

Figure 5. Preparation of soil for treatment with common rock salt.

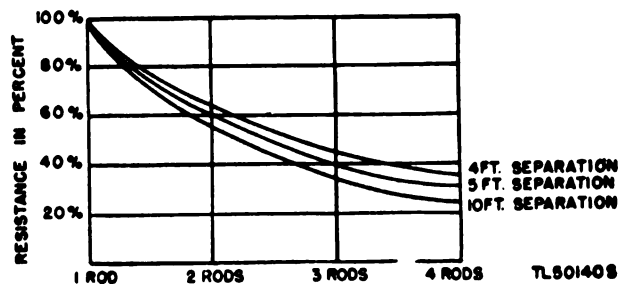

Figure 6. Decrease in resistance with ground rods in multiple.

further reduce ground resistance. The approximate reduction in resistance obtained with two or more ground rods connected in parallel compared with the resistance of one rod is indicated in figure 6. However, no appreciable gain will be obtained by using more than four ground rods. The distance between driven rods connected in parallel should not be less than 10 feet.

4. Metallic and Ground-Return Circuits

a. GENERAL. Wire circuits may be classified as full-metallic or ground-return, according to the electrical paths they follow. An electrical circuit which is completed solely through metallic conductors is a full-metallic circuit. A circuit in which a metallic conductor provides one side of the electrical circuit, and the earth the other side, is a ground-return circuit.

b. FULL-METALLIC CIRCUIT. Figure 7 shows a full-metallic teletypewriter circuit. Starting at negative battery, the circuit goes through a current-limiting resistor, selector magnets, and transmitter contacts of teletypewriter A, through a metallic conductor, teletypewriter B, and the other conductor to positive battery. Generally, circuits which provide a completely metallic path are more satisfactory than ground-return circuits because there is less leakage, less danger of cross-fire and outside interference, and, in the long run, less circuit line-up and need for attention.

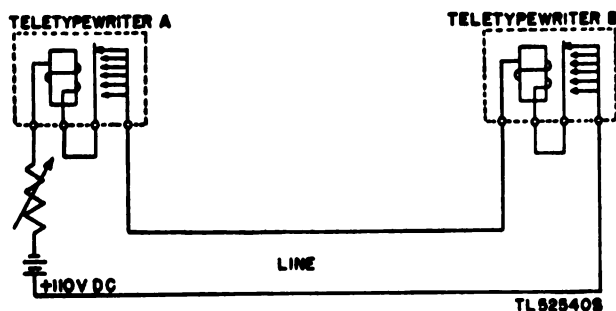

Figure 7. Full-metallic teletypewriter circuit.

c. GROUND-RETURN CIRCUIT. Figure 8 shows a ground-return teletypewriter circuit with two teletypewriters connected in series. The path of the circuit is the same as the full-metallic circuit described in b above, excepting that the return path from teletypewriter B to the battery at teletypewriter A is accomplished through the ground instead of the metallic conductor. In most instances, a ground-return circuit is more economical because wire is saved by using the earth as one of the con-

ductors in the circuit. Ground-return circuits also will reduce wire maintenance, and if low-resistance grounds are obtained, there will be lower over-all resistance for the circuit than with a complete metallic circuit. However, ground return systems are susceptible to leakage, constant changes of resistance during wet and dry weather, inductance from power circuits, and especially to interception by the enemy.

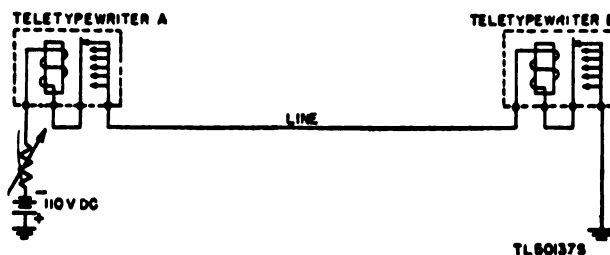

Figure 8. Ground-return teletypewriter circuit.

5. Theory of Repeating Coil

a. GENERAL. A full-metallic circuit may be used simultaneously for telephony and telegraphy without interference between the two means of communication by the use of repeating coils. One such coil, Coil C-161, is a highly efficient 1 to 1 ratio transformer. It is composed of four balanced windings, each winding with 21 ohms resistance. Two of these 21-ohm windings are connected in series to complete each side of the transformer. The windings of one side of the transformer (primary) are brought out to terminals marked SWBD; the windings of the other side of the transformer (secondary) are brought out to terminals marked LINE 1 and LINE 2, as is shown in figure 9. In addition to the two line terminals, a third terminal is connected between the two 21-ohm windings of the line (or secondary) side of the transformer to pro-

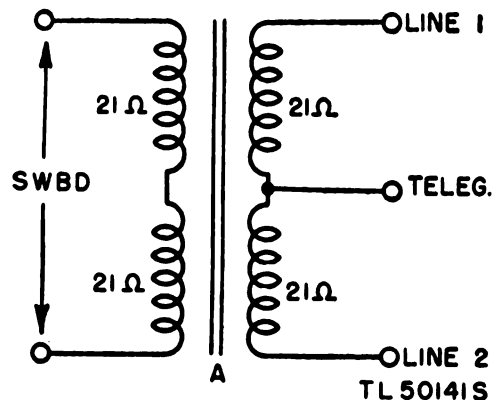

Figure 9. Schematic diagram of repeating Coil C-161.

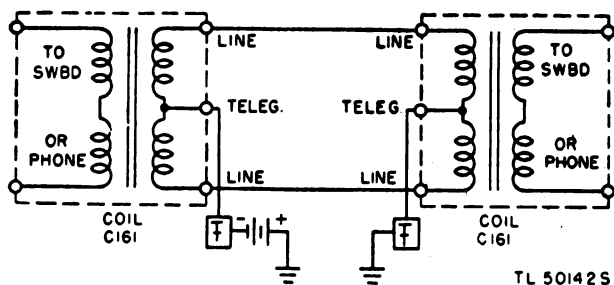

Figure 10. Telephone circuit simplex to provide additional teletypewriter channel.

vide the telegraph leg from which the simplex circuit will operate. (See fig. 10.)

b. **SIMPLEX CIRCUIT.** Where only one trunk exists between two centrals and both telephone and telegraph communication is desired, the laying of an additional metallic circuit can be eliminated by the use of a repeating coil inserted at each end of the circuit as shown in figure 10. Refer to figure 11; a path for voice currents at a given instant may be traced from Telephone EE-8 at station A, down through the switchboard (or primary) side of the repeating coil. Since the repeating coil is an efficient 1 to 1 ratio transformer, any surge of current through the primary winding will induce a like surge of current through the secondary winding. However, this induced current will be in the opposite direction. (This is the principle upon which all transformers work.) The path of induced current may be traced upward through the secondary winding of the left-hand repeating coil, through the top wire of the trunk, down through both windings of the secondary side of the right-hand repeating coil, and back along the bottom wire to its starting point. This surge of current downward through the secondary winding of the right-hand repeating coil will induce an equal and opposite surge of current upward through the primary side of the right-hand repeating coil. The path of the latter induced current may be traced upward through the primary winding of the right-hand repeating coil, through Telephone EE-8, then back to the place of origin. For clarity and to facilitate tracing, these currents are shown as solid arrows. At the same time that voice currents are flowing, the teletypewriter station at A is connected to the teletypewriter at station B. The teletypewriter circuit is traced from the positive side of battery through the teletypewriter at station A. The signals transmitted by this machine are d-c signals which travel up the single wire to the terminal marked TELEG to the secondary winding of the repeating coil, having two paths of equal

resistance. Therefore, the current will divide. One part will go up through one winding of the secondary. The other will go down through the lower winding. Part of the current surges upward through one winding and part downward through the other winding. Since any current surge through one side of the transformer will induce a current equal in intensity though opposite in direction in the other side, the currents in the primary of station A are of equal intensity and opposite in direction and therefore are neutralized. To aid in tracing, these teletypewriter d-c current signals are shown in figure 11 as broken arrows. These teletypewriter signals pursue parallel paths along both the top and bottom wires, half through the upper winding of the secondary and half through the lower winding of the secondary at station B repeating coil. The same neutralizing process that took place at station A repeating coil again takes place and no current is induced in the primary winding of the repeating coil at station B. The teletypewriter signal currents that traveled down through the top half and upward through the bottom half of the secondary winding join at the TELEG leg at station B repeating coil and travel down the single teletypewriter wire, through the teletypewriter at station B, to negative battery.

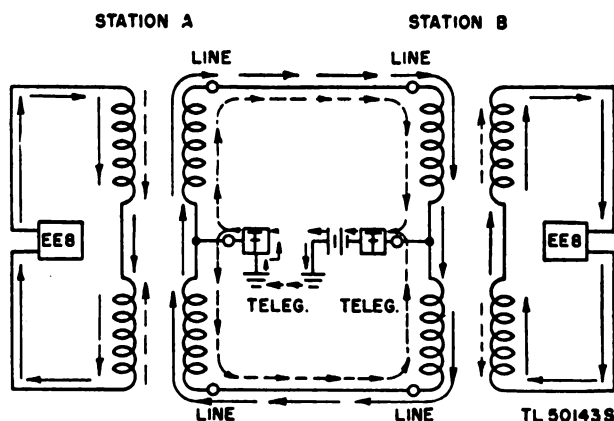

Figure 11. Simplex telephone circuit showing current paths.

c. **PHANTOM CIRCUITS.** Instead of using ground-return for a simplex teletypewriter circuit, metallic return path may be provided by simplexing a second metallic telephone circuit if one is available. Utilizing the simplex of two metallic circuits to provide a third channel will create what is called a *phantom* circuit. This sometimes may be done when good connections for satisfactory operation of a teletypewriter channel are difficult to obtain.

This phantom circuit is nothing more than two simplex circuits combined. The two metallic circuits (fig. 12) are called *physical* circuits (or side circuits) to distinguish them from the phantom circuit, and the three together are known as a phantom group.

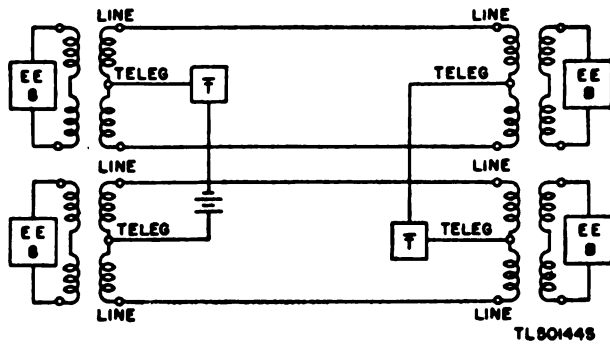

Figure 12. Phantom group.

d. **SIMPLEXED-PHANTOM CIRCUIT.** Phantom circuits may in turn be simplexed for telegraph and thus three telephone circuits and one telegraph circuit may be obtained over two pairs of wires. Figure 13 shows a simplexed phantom group. Theoretically an additional circuit should be derived from this group and another similar group but the problems involved in transposing and maintaining it make it impracticable.

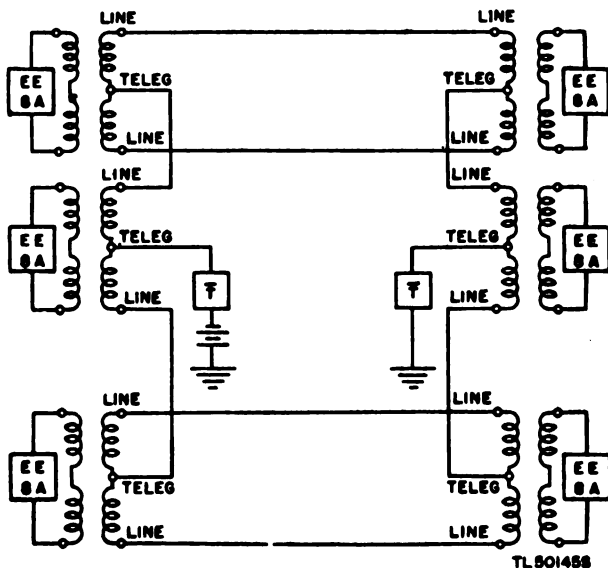

Figure 13. Simplex phantom circuit.

e. **WAY STATIONS IN SIMPLEX AND PHANTOM CIRCUITS.** To establish a way station in a simplex circuit, it is necessary to use two more repeating coils. (See fig. 14.) A way station is usually in-

stalled at an intermediate telephone switchboard. If a teletypewriter is to be set up at a way station, in no case should a ground be installed, since it would cause one station to be shorted out. If the teletypewriter line passes a telephone switchboard, it is necessary to bridge the circuit around the switchboard by means of a shunt wire from the TELEG legs of the repeating coils on each side. This shunting or bridging around the terminal frame of the intermediate switchboard applies to both phantom and simplexed teletypewriter circuits.

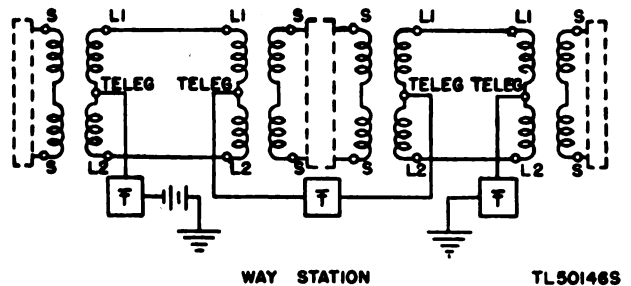

Figure 14. Way station at an intermediate switchboard.

f. **EFFECTS OF REPEATING COILS ON TRANSMISSION.** The introduction of repeating coils into a circuit slightly reduces the transmission range of that circuit. This slight impairment of efficiency is negligible and can be disregarded in view of the extra channel the physical circuit is made to provide. Simplex and phantom circuits are more efficient than the side circuits upon which they are superimposed because they afford parallel paths and consequently have less resistance. When the resistance of the line wires is not equal, there is interference in the side circuits because of the teletypewriter impulses. This line unbalance will not cause any trouble in the teletypewriter circuit because the telephone voice currents are not strong enough to affect the printer, and even more important, the inductance of the teletypewriter relay or magnets is too great to allow voice currents to pass in any appreciable amount. A simplex teletypewriter circuit may continue to be operative under certain trouble conditions which render the physical circuit on which it is superimposed inoperative for telephone communication. When the simplex circuit is broken down and compared with the basic circuits already studied, it can be recognized as a ground-return circuit. The only difference is that, instead of having a single line wire to the metallic side of the circuit, it has two in parallel. Thus the simplex teletypewriter circuit will operate, or be

made to operate, even though one side of the physical circuit is open.

6. Composite Sets

Figure 15 illustrates the composite set, which allows a grounded telegraph circuit to be superimposed on each of the two wires of a telephone circuit. No interference with use of the telephone circuit as one side of a phantom circuit results. Inductance of the retardation coils in series with the telegraph leg and capacitors connected in parallel to ground balances the circuits; the design is to prevent quick changes in values of telegraph current that could cause noises such as clicks and thumps in the telephone circuit. The coils also prevent any quick building up of current when marking impulses are being sent, and slows current decreases when spacing impulses are sent. The capacitors help retardation by storing electricity while marking impulses are sent and then releasing it through the retardation coils when spacing impulses are sent. All this is designed to make it possible for current to reach the line wire with a less abrupt change than occurs in the current at the teletypewriter. The capacitors block d-c teletypewriter signals from reaching the telephone equipment and causing interference with telephone operation. The retardation coils and capacitors also prevent cross-fire, a

condition in which telegraph signals sent over one wire of a telephone circuit induces great enough voltages to interfere with signals on the other wire, or operate signaling relays on the telephone circuit.

7. Line Leakage

a. CAUSE. In practice, the insulation between conductors is never perfect. High-resistance paths exist between conductors all along a line, which permit current leakage from one conductor to another. In wet weather the insulation resistance of the conductor is reduced, allowing greater current leakage. The leakage may not be very great at any one point, but with the many paths provided along a long stretch of line, the sum of these current leaks may become of sufficient magnitude to affect teletypewriter operation. A poorly taped splice or, even worse, an untaped splice can cause a leak to ground over which it will be impossible to signal.

b. EFFECTS. Leakage may become so great in wet weather that correct operation of a teletypewriter is not possible. A teletypewriter circuit without line leakage has a difference of 60 milliamperes (ma) between marking and spacing impulses (600). This difference may be changed if line leakage occurs. For example, in figure 16 when teletypewriter A send a spacing impulse, zero current will flow through teletypewriter B and when a

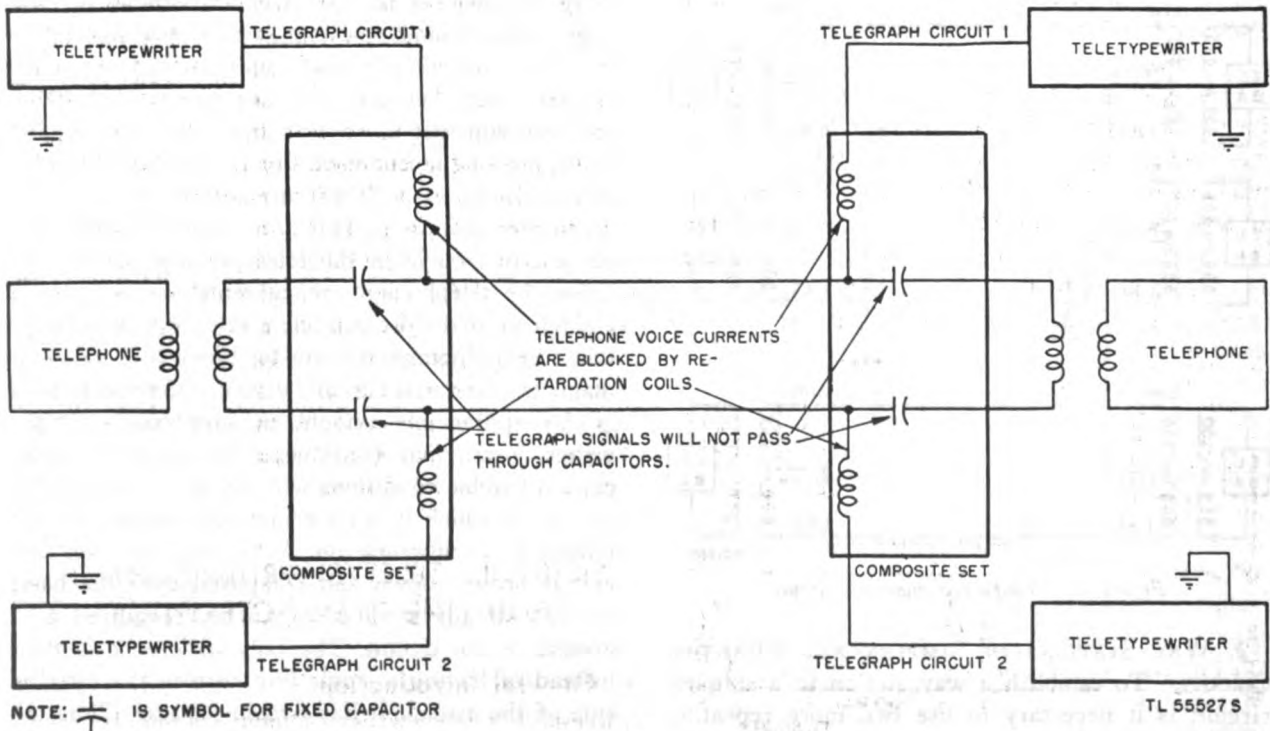

Figure 15. Composite sets.

marking impulse is sent, 30 ma instead of the normal 60 will flow through teletypewriter B, giving a difference of 30 (30-0). When teletypewriter B sends a spacing impulse, 30 ma will continue to flow through teletypewriter A because of the leak, giving it a difference between marking and spacing impulses of 30 (60-30). It is evident that as the leakage is increased the difference will decrease, having a greater effect at each station, until it becomes necessary to counteract this leakage in order to operate.

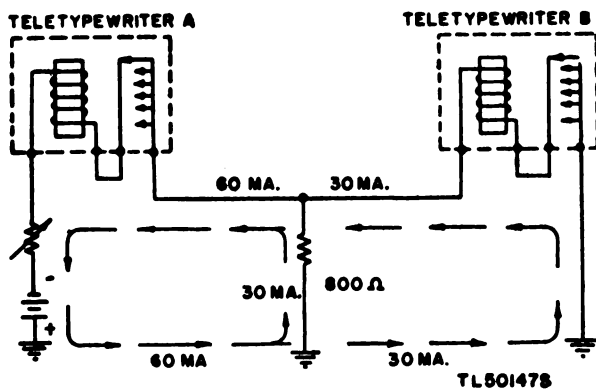

Figure 16. Circuit with line leakage.

c. METHODS OF COUNTERACTING. By dividing the battery, that is, applying equal voltage at each end of the circuit, a greater difference may be obtained. In figure 17 each battery is supplying 30 ma. When teletypewriter A sends a space signal, there will be 15 ma flowing through teletypewriter B because of the leak, giving it a difference of 45 (15 to 60). When teletypewriter B sends a spacing signal, the same condition applies as when A is sending. A comparison of figures 16 and 17 will show that the current leakage has decreased 50 percent and a greater difference between marking and spacing impulses has been obtained. Note that when a marking impulse is sent, current leakage is entirely canceled.

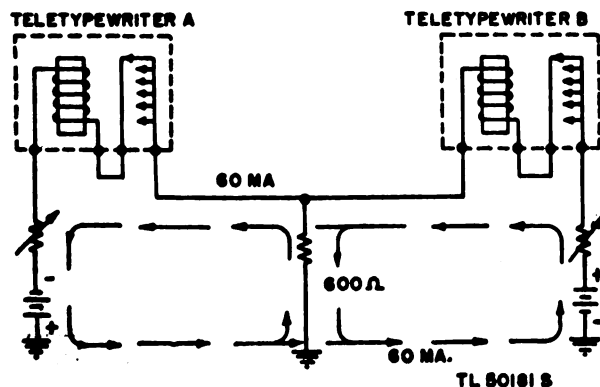

Figure 17. Circuit with line leakage and divided battery.

8. Theory of Carrier Systems

Fundamentally a telegraph carrier system (fig. 18, uses a relay circuit operating from d-c impulses. This relay alternately opens and closes the circuit to a source of a-c current of a definite frequency, thus permitting surges or spurts of the alternating current to be impressed upon the signal line. At the distant end of the system, the surges of alternating current are passed through a piece of equipment which serves to convert the a-c impulses to d-c impulses having the same characteristics as the original. These d-c impulses operate a receiving apparatus. The main advantage of a carrier system is that several messages may be conveyed simultaneously over the same physical line. Figure 3 illustrates the basic principle of an Army field carrier telegraph system. Each complete circuit (for example, from teletypewriter station 1 at terminal A to teletypewriter station 1 at terminal B) is called a channel. (See fig. 18.) The arrangement of the terminal equipment is such that only those channels having the same number can operate together. That is, channel 1 with channel 1, 2 with 2, etc. Each channel has its own oscillator, modulator, and demodulator. The modulator contains relay equipment which operates on the d-c impulses from the station teletypewriter to interrupt the a-c output of the oscillator. The spurts of alternating current pass through the repeating coil, over the line, through the repeating coil at the distant terminal, and into the demodulator associated with that particular channel where the a-c impulses are reconverted into direct current to operate the station teletypewriter receiving mechanism. For transmission in the opposite direction, a different carrier frequency is used to eliminate the possibility of interference when both stations send simultaneously. The carrier frequencies used for each channel must be separated widely enough to prevent their crossing into each other during transmission. The use of a carrier system not only extends the message-carrying capacity of the line facilities but also extends the distance over which these messages can be sent as compared with d-c systems.

Section II. TELETYPEWRITER SIGNALS AND LINE CHARACTERISTICS

9. General Introduction

Successful teletypewriter communication between two or more points at a fairly rapid rate, 60 words

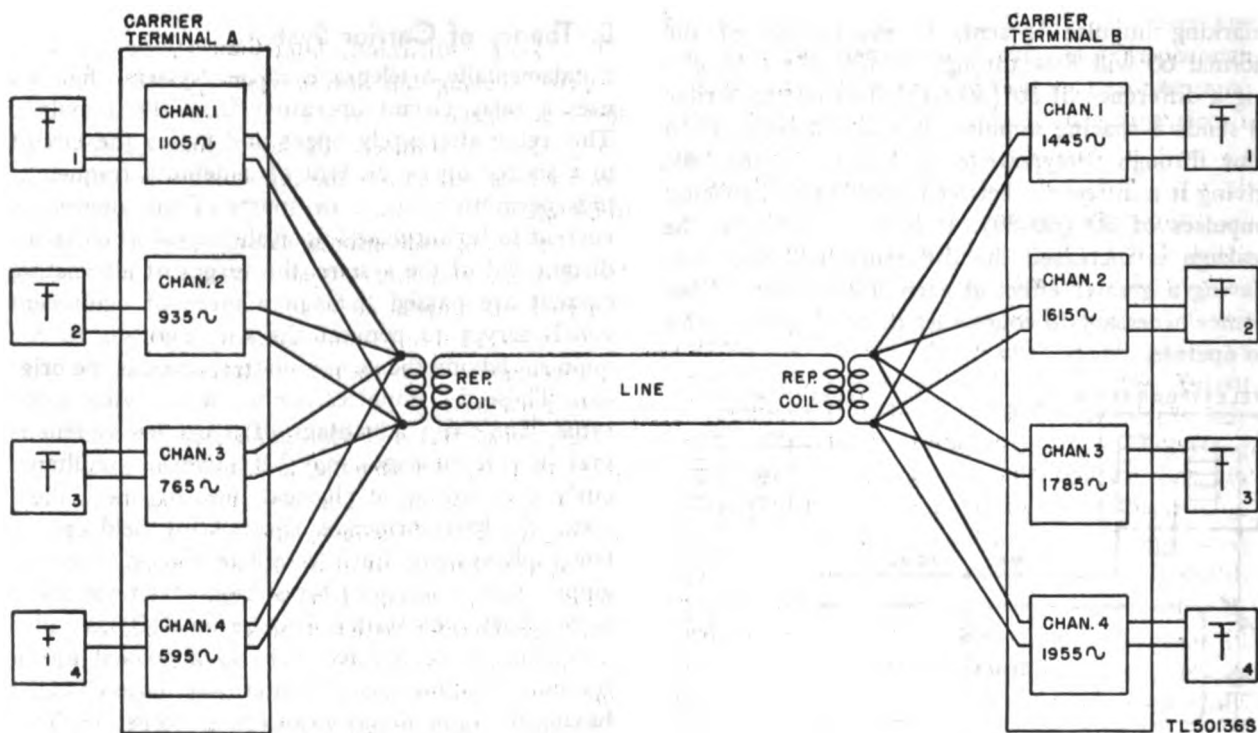

Figure 18. Block diagram showing action of a carrier system.

per minute, requires a carefully engineered circuit as well as accurately adjusted equipment. Any transmission system, whether direct current or carrier, contains line characteristics (resistance, inductance, capacitance, line leakage) which tend to distort or impede any signal sent over it. The purpose of the following paragraphs is to explain the nature of teletypewriter signals and the effect of line characteristics upon these signals.

10. Nature of Teletypewriter Signals

As pointed out in paragraphs 1 through 8, there are two general methods of transmitting teletypewriter signals:

(1) Neutral transmission in which current flows over the line for a mark impulse and no current flows over the line for a space impulse; and,

(2) Polar transmission which is accomplished by changing the direction of current flow for mark and space impulses.

In neutral operation, the closed circuit is referred to as a mark or marking impulse, and the open circuit is known as a space or spacing impulse. In polar operation the marking and spacing terms are retained, but here they refer to the direction of current flow rather than to the open and close condition as in neutral operation. The change of cur-

rent from marking to spacing condition, or vice versa, can be plotted with respect to time. In either polar or neutral operation the change from one current condition to the other, that is, from mark to space or space to mark, is known as a transition. A diagram on which this change of current from one condition to the other is plotted is called a waveshape diagram or more commonly a waveshape. Waveshapes are an important aid in the study of teletypewriter transmission since they show graphically the change of current in teletypewriter circuits.

11. Waveshapes in Neutral Teletypewriter Systems

a. THEORETICAL. (1) Field telegraph circuits used by the Army usually operate on a neutral basis. A simple manual neutral telegraph circuit is shown in figure 19. Each end of the circuit contains a key for sending and a sounder for receiving. A battery is connected in series at one end, with a variable resistor for adjusting line current. The keys at each end are normally kept closed, and current flows throughout the entire circuit. After the line current has been adjusted to the proper value, either station operator can signal the other by proper operation of his key. From the stand-

point of operation, transmission is half duplex, that is, both stations can send but not at the same time. The circuit shown in figure 19 can be converted into a neutral teletypewriter circuit by substituting teletypewriters for the keys and sounders. The keyboard contacts of the teletypewriters are connected in place of the keys, and the receiving magnets of the teletypewriters are connected in place of the sounders. A simple neutral teletypewriter circuit as described is shown in figure 20. The standard speed of Army teletypewriters is 60 words per minute except when operating with British equipment. The average word is assumed to consist of five letters and a space, and, therefore, six revolutions of the transmitting cam assembly are required for each word. At 60 words per minute there are 60 times 6 or 360 revolutions per minute (rpm) of the transmitting cam sleeve. However, since the transmitting cam sleeve is started and stopped once every revolution, the driving shaft is operated slightly above this speed, that is, 368 instead of 360 rpm. The transmitting shaft, then, makes one complete revolution sending a start impulse, five selecting impulses and a stop impulse in 0.163 second (163 milliseconds). To insure that under any consideration normally encountered, the receiving mechanism will come to a stop before the next combination is received, the stop impulse is longer than the other six impulses. Therefore, when operating at 60 words per minute, the time for each unit impulse is 22 milliseconds and the time for the long stop impulse is 31 milliseconds. The normal line current for neutral teletypewriter operation is 0.060 amperes (amp) or 60 ma. When station A (fig. 20) wants to send the character Y to station B, the operator at station A simply presses the Y key. This causes the keyboard contacts to operate in such a manner that the signal (fig. 21) is transmitted to the line. The sequence of the operation of the keyboard contacts (fig. 21) is as follows:

(a) t_0 —The operator depresses the Y key, which sets the apparatus in motion and causes the start-stop contact to open the line.

(b) t_1 —22 milliseconds later than t_0 , contact No. 1 closes and causes the line current to increase to 60 ma.

(c) t_2 —44 milliseconds later than t_0 , contact No. 1 opens, causing the line to open (contact No. 2 does not close).

(d) t_3 —66 milliseconds later than t_0 , contact No. 3 closes and causes the line current to increase to 60 ma.

(e) t_4 —88 milliseconds later than t_0 , contact No. 3 opens, causing the line to open (contact No. 4 does not close).

(f) t_5 —110 milliseconds later than t_0 , contact No. 5 closes and causes the line current to increase to 60 ma.

(g) t_6 —132 milliseconds later than t_0 , contact No. 5 opens and the start-stop contact closes; the line current remains at 60 ma.

(h) t_7 —163 milliseconds later than t_0 , the sending mechanism is ready for the transmission of the next character.

(2) These transmitted signals are perfect signals; that is, the spacing and marking impulses with the exception of the stop impulse are equal in length, 22 milliseconds, and the mark-to-space and space-to-mark transitions are instantaneous, making the waveshape square. (See A of fig. 23.) However, characteristics of teletypewriter circuits and apparatus are such that signals transmitted sometimes fail to reproduce at the receiving end the same character transmitted. In other words, the signal transmitted over the line may undergo

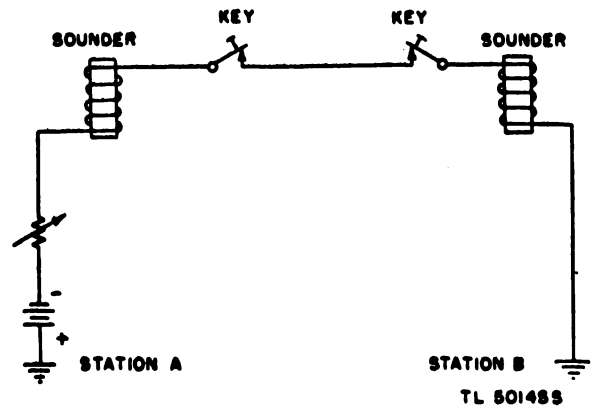

Figure 19. Neutral manual telegraph circuit.

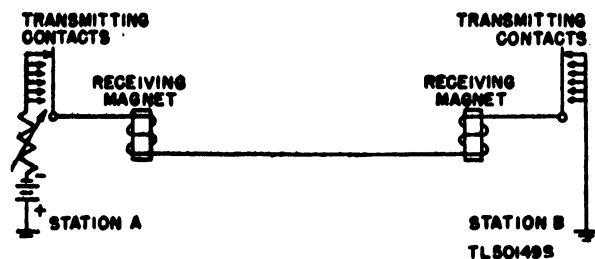

Figure 20. Simple neutral teletypewriter circuit.

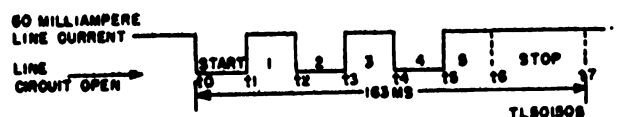

Figure 21. Theoretical diagram of character Y.

certain changes which tend to alter its characteristics.

b. **ACTUAL.** Teletypewriter signals when transmitted over a line are affected by line characteristics that tend to distort the signals. Capacity and inductance are the most important of these distorting characteristics. A capacitor consists of two conducting plates separated by a dielectric. In a teletypewriter circuit (fig. 22) the wire and ground beneath it constitute the two conducting plates and the insulation and air between them constitute the dielectric. The capacity of the entire circuit is shown as a capacitor in the center of the circuit. As the capacity of a capacitor is governed by the area of the plates and their separation, so the capacity of a circuit is governed by its length and distance between conductors. When a transmitting contact (fig. 22) closes, the first rush of current flows only in part to the receiving relay since the current is diverted to the capacitor until the capacitor is charged to full capacity. As the capacitor is charging, it tends to discharge in the same path as the originally applied voltage, thus allowing more and more current to flow through the relay. When the capacitor is fully charged it will be of the same potential as was originally applied, and all the current will flow through the receiving relay. This delaying action causes the waveshapes to be curved or rounded at the beginning and results in delayed space-to-mark transition. When current starts to flow through the coils of the relay, a counter-electromotive force (EMF) is set up in opposition to the applied EMF because of inductance of the relay. This tends to delay the current flow through the winding and helps to divert the current flow to the capacitor. When the current is built up to its maximum, the counter-EMF is no longer present and the original current value is allowed to go through the coil. Therefore the current that flows through the relay does not rise at once to its final value but builds up along a curve. (See B of fig. 23.) Even when an appreciable voltage is applied to the relay, there is a delay before the current in the relay builds up to a value sufficient to operate the armature. Both capacity and inductance, then, cause a time delay in the space-to-mark transition, resulting in the front of the waveshape becoming curved or rounded. (See C of fig. 23.) When the transmitting contact opens, inductance and capacity once more come into play. Inductance of the relay tends to keep current flowing through it until the contacts are no longer arcing. The capacitor cannot discharge through the open contact and

therefore will discharge through the relay, causing the time delay in the mark-to-space transition, thereby causing a slope on the back of the waveshape. (See C of fig. 23.) Figure 23 is a comparison of the waveshape transmitted, the waveshape distorted by inductance, and the waveshape distorted by both inductance and capacity. The shaded portion of C of figure 23 represents the effect of the capacity over and above the effect of the inductance.

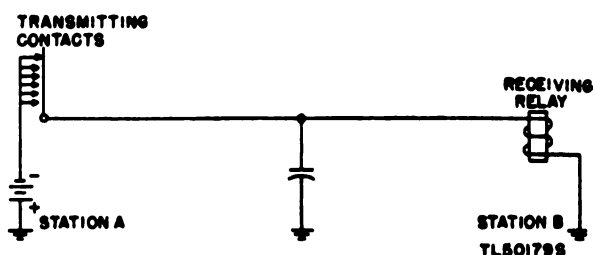

Figure 22. One-way neutral circuit.

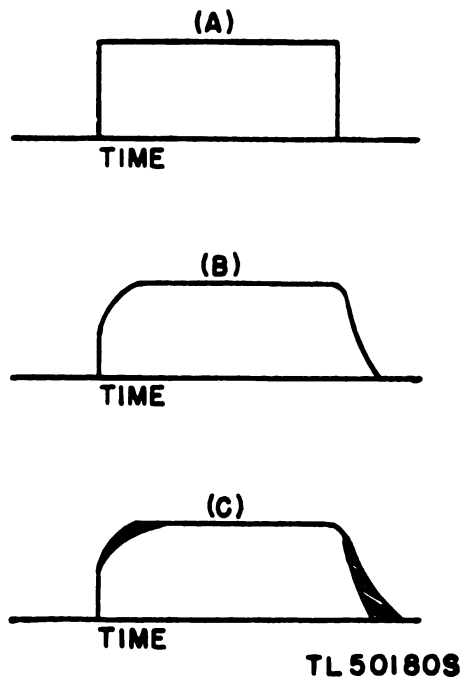

Figure 23. Comparison of waveshape.

c. **EFFECTS OF DISTORTION.** Practically all teletypewriters are used in conjunction with a receiving relay which operates on a distorted signal and repeats a square waveshape (no time delay in the space-to-mark or mark-to-space transition). However, this repeated signal may contain marking or spacing bias. Marking bias exists when the marking impulses are longer than the spacing impulses. Spacing bias exists when the spacing impulses are

longer than the marking impulses. Any telephone or telegraph relay has a definite operating current value for any given adjustment. Figure 24 shows a neutral telegraph relay with its winding connected in series with a rheostat, battery, and milliammeter. If the rheostat is adjusted so the resistance in the circuit is too great to permit operation of the relay and the resistance is then gradually reduced, there will be a definite milliammeter reading at which the armature of the relay operates. This reading is called the operating current value of the relay for the particular adjustment. If, after the relay is operated, the rheostat is adjusted in the other direction, to increase resistance of the circuit, this relay armature will be pulled back at a definite milliammeter reading. This is called the release current value for the particular adjustment. Points O and R (A and B of fig. 25) represent the operating and release current values, respectively, for a relay such as shown in figure 24. With this particular adjustment, the length of the signal repeated by the relay will be the time indicated by T. Now, if certain adjustments are made on the relay, either by weakening the tension of the retractive spring, lessening the air gap between the pole pieces and the armature with the adjusting screw, or decreasing the stroke of the armature by adjustments of the contact and backstop screws, the operating and release current values may be decreased to

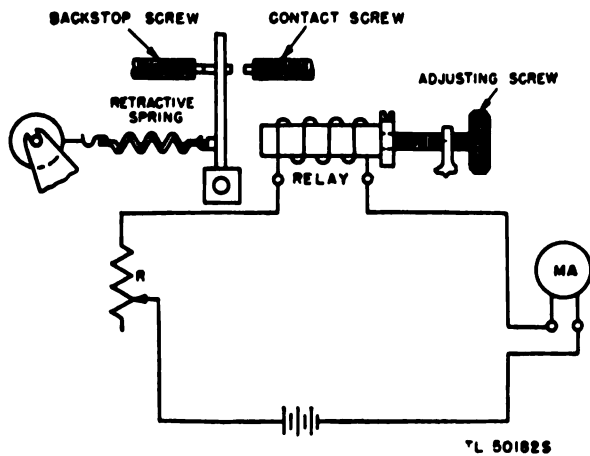

Figure 24. Circuit for measuring operating and release current values.

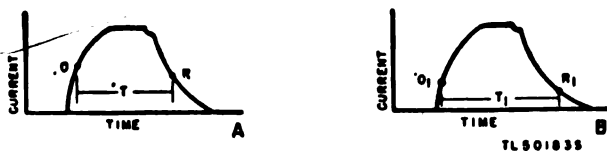

Figure 25. Effect of relay adjustment on signal lengths.

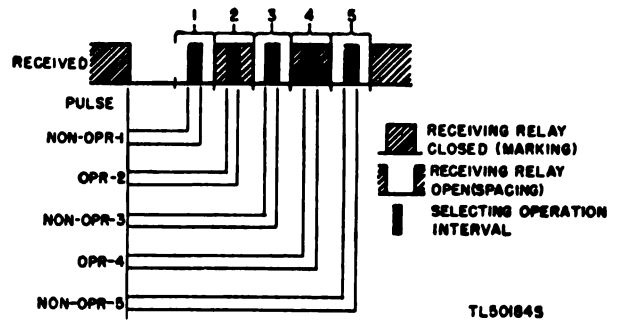

Figure 26. Received signals of character R (zero bias).

those represented by $O_1 - R_1$ in B of figure 25. The effect would be to increase the length of the marking impulse repeated by the relay, from the time represented by T to that represented by T_1 .

(2) A relay repeats a signal without time delay in transition. However, the length of marking impulses in comparison to spacing impulses may be incorrect, according to the adjustment of the relay. For perfect signals (zero bias) each marking impulse should be the same length (22 milliseconds) as each spacing impulse with the exception of the stop impulse (31 milliseconds). The function and operation of the different types of relays will be explained in later sections. Figure 26 shows the sequence of circuit conditions produced by the relay contacts in repeating the letter R to a receiving mechanism. Shaded areas represent intervals during which the circuit is opened by transmitting contacts. Solid blocks superimposed upon the received signals represent the selecting interval or those parts of signals which are used by the selecting mechanism of the receiving machine. The receiving mechanism when oriented correctly is arranged so that it normally operates only during the central portion of the received impulse and requires only about 20 percent of that impulse. The time length from the edge of each selecting interval to the adjacent transition is $2/5$ of the length of the impulse which indicates that the transitions may be shifted toward the selecting intervals as much as 40 percent of the length of the impulse before an error is recorded on the machine.

(3) As has been shown in the preceding subparagraphs, distortion in the form of bias displaces the signal transitions to shift effectively the position of the received mark or space impulses in a definitely systematic way. The ideal situation is for the selecting intervals of the receiving unit to be at midposition with respect to the sending units. The receiving unit of the teletypewriter is equipped

with a mechanism whereby a latch assembly may be moved mechanically through an arc corresponding to the length of a unit segment or perfect impulse. By this means all the selecting intervals may be shifted with respect to the beginning of the start impulse over a scale range equal to a perfect impulse (22 milliseconds for 60 words a minute). This mechanism is known as the range finder and is equipped with a scale from 0 to 120. One hundred divisions on this scale represent an arc equal to a unit segment or 100 percent of an impulse. When the range finder arm is moved toward the lower numbers, it is in effect moving all selecting intervals to the left. When the arm is moved to the higher numbers, the selecting intervals are moved to the right. When an impulse or signal is perfect, the range of the impulse is 100 percent, equalling 0 to 100 on the range finder. Since the ideal position for the selecting intervals is the center of the impulse, the range finder arm should be set on 50. The selecting mechanism must use 20 percent of the impulse and since the range finder is set on 50, the 20 percent will come from the exact center of the impulse and leave a total of 80 percent, 40 percent on each side. (See fig. 26.) Therefore, the range arm can be moved 40 points each way without receiving a wrong impulse, resulting in a range of 10 to 90 (50 minus 40—50 plus 40) or 80 points. Figure 27 shows what happens when a marking bias of 40 percent is present. Notice that the selecting intervals may still be moved to the left by 40 percent. The marking impulse becomes longer; this makes it impossible to move the selecting intervals of the spacing impulses to the right without picking up the wrong impulse (mark instead of space). The range finder arm, then, can be moved 40 percent to the lower numbers or on 10 on the range finder. If the range finder is moved to the higher numbers, however, the selecting interval of the spacing impulse would be at a marking impulse when it should be at a space and thus cause printing of a wrong character. The range in this case would be 10 to 50, or 40 points on the range finder. Figure 28 shows the character R received with a 40 percent spacing bias. In this case when the range finder arm is moved to the lower numbers (selecting intervals to the left) a wrong impulse would be picked up (spacing instead of marking) by two of the selecting intervals on the marking impulses. This would cause the wrong character to be printed. However, the arm may be moved to the high numbers (selecting intervals to the right) by 40 points without receiving a wrong impulse. The range in

this case would be 50 to 90 on the range finder scale. To measure net effect of all kinds of systematic distortion, or position of received signals, the range finder arm is first moved in one direction until errors appear in the copy and then moved back slowly until these errors are first eliminated. Similarly, the range finder arm is moved the maximum distance in the opposite direction. These two scale readings then give the operating margin of the signals under test. On perfect signals the margin would be from 10 to 90, 80 points, but with either marking or spacing bias this margin would not be so great. With marking bias the high part of the range would be affected, and when a spacing bias is present, the low part would be affected.

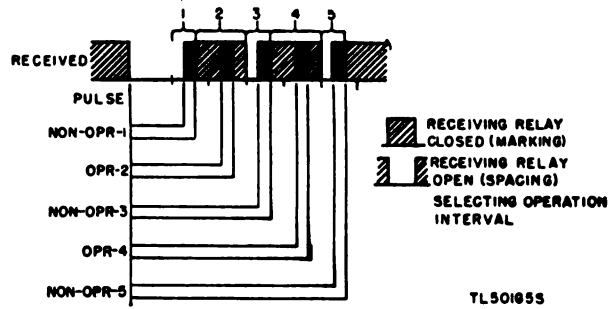

Figure 27. Received signals of character R (marking bias).

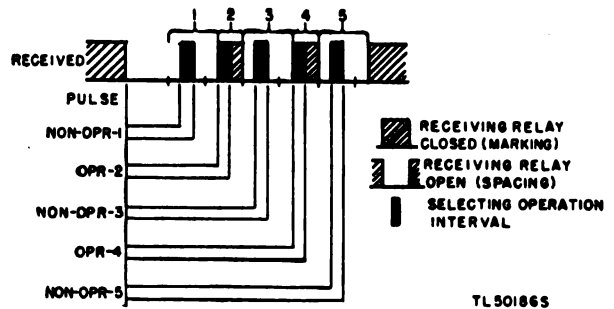

Figure 28. Received signals of character R (spacing bias).

12. Polar Waveshapes

a. THEORETICAL. As pointed out in paragraphs 1 through 8, a polar telegraph circuit is one in which current is present in the line for spacing impulses as well as for marking impulses. The line current value is equal but of opposite polarity, usually adjusted to positive 30 ma for a marking impulse, to negative 30 ma for a spacing impulse. If the operator at station A (fig. 29) depresses the Y key, the waveshape of the signals will be as shown in figure 30. This is without distortion of any kind, making the mark-to-space and space-

to-mark transitions instantaneous. Note that the time required for each impulse is 22 milliseconds just as it is for neutral operation.

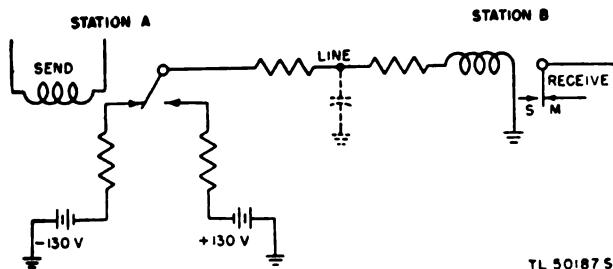

Figure 29. One-way polar teletypewriter circuit.

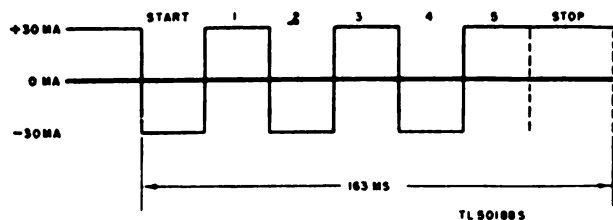

Figure 30. Theoretical diagram of character Y.

b. ACTUAL. In polar circuits, as in other circuits, the characteristics of the line are such that they cause the space-to-mark and the mark-to-space transitions to be delayed. As in neutral operation, the primary cause of the delay is the capacity from line to ground plus the inductance of the relays. Since the action of the two properties working together was explained under neutral operation, it is unnecessary to explain it again. For the sake of simplicity, therefore, only the capacity will be considered. When the line current is marking, the voltage on the capacitor representing the capacity to ground is negative and while the line current is spacing, this voltage is positive. When a marking impulse is transmitted at station A (fig. 29), the current flowing in the line must build up a charge on the capacitor just as in a neutral system, and thus delays the build-up to full marking current value in the receiving relay of station B. This delay is illustrated in figure 31. When the line current is changed from marking to spacing, the voltage on the capacitor must make a complete change from negative to zero to positive. The line current from the discharging capacitor flows in the same direction as the originally applied line current and tends to keep that line current flowing in the relay. Then, when positive spacing current begins to flow, it builds up a charge on the capacitor and thus delays the build-up of the spacing current to its full value.

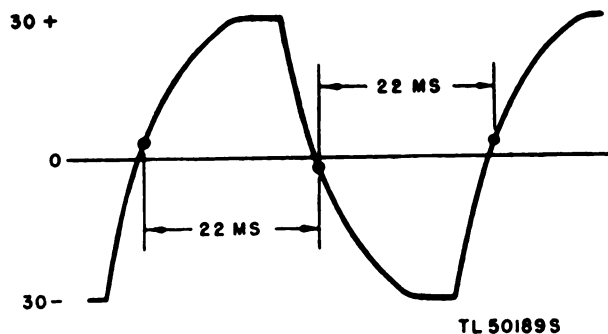

Figure 31. Signal waveshapes in polar teletypewriter circuits.

c. EFFECTS OF DISTORTION. These two actions of the capacity of the line combine to make the transition of the line current from marking to spacing a gradual change as shown in figure 31. The fact that the space-to-mark and the mark-to-space waveshapes are identical is the most valuable feature of polar operation because the space and mark impulses repeated by the relay are of the same length even though the original signals to the relay are distorted. With properly adjusted relays, the operating points are located in the same position on each wave and the action of teletypewriter equipment used on polar operation is very good under practically any line conditions. Since polar signals cannot be sent directly from a standard teletypewriter keyboard, it is necessary to use some type of pole-changing device to secure polar operation. This is ordinarily some form of repeater.

Section III. BASIC TELETYPEWRITER CIRCUITS

13. General Introduction

Basically a teletypewriter consists of three electrical units: Receiving unit (line relay or printer magnets), sending unit (keyboard contacts), and motor. As an aid in studying these three units, complete schematic and wiring diagrams are made a part of this section.

14. Basic Circuits

a. LINE CIRCUIT. The line circuit is the signaling circuit connected to the line winding of the relay and transmitter contacts. When a marking impulse is sent, the armature of the relay is pulled to the marking contact, causing the impulse to be repeated to the printer magnet.

b. MAGNET CIRCUIT. The marking contact of the

relay is in series with the magnet circuit. When the relay armature is against this contact (marking impulse), it completes the magnet circuit which has the printer magnet in series, and thereby carries the repeated signal to the selector unit.

c. **BIAS CIRCUIT.** The bias circuit is connected to the bias winding of the relay. This circuit can be considered a spring having constant pull on the armature equal to half the pull of the line current. When no current is flowing in the line circuit (spacing impulse), this "spring" causes the armature to be pulled to the spacing contact.

d. **SHUNT CIRCUIT.** The spacing contact of the relay is in series with the shunt circuit. When the relay armature is against this contact, it completes the shunt circuit which is designed to keep a constant drain on the rectifier regardless of the position of the relay armature (magnet circuit when the armature is on mark, shunt circuit when the armature is on space).

e. **MOTOR CIRCUIT.** The motor circuit carries power for the motor regardless of type (alternating current or direct current).

f. **REFERENCE.** For detailed information on the local circuits of the M-15 teletypewriter, refer to TM 11-2215.

15. WECO Polar Relays 215 and 255 Type

a. **GENERAL.** Because relays are more sensitive receiving units than printer magnets, they generally are used with fixed station equipment to allow greater operating distances between machines. The relay used with the M-15 machine is a polar relay of the 215 or 255 (Western Electric Co.) type. Each of the two windings in the 215 type has 85 ohms resistance and is designed for 60 ma of signaling current only. The windings of the 255 are 136 ohms each and can be used on 20 to 60 ma of signaling current. In addition, the 255 type has large knurled pole piece locknuts which make it easier to adjust the pole pieces, and its contacts are of later design and better materials. Because both types are identical in operational features, the following description applies to both.

b. **POLAR OPERATION.** Figure 32 illustrates a 215 or 255 type relay used for polar operation (only one winding). The magnet is a permanent magnet made of hard steel. The two yokes, armature, and the pole pieces are made of permalloy, which is a special alloy that conducts magnetic lines of force in the same manner as soft iron. The relay armature is a thin spring clamped at its base. It can be

flexed from the marking to the spacing contact but, because it is a spring, it stands midway between the pole pieces when no current flows in the winding. Magnetic lines of force pass from the north pole N of the permanent magnet, through the upper portion of the left yoke and the north pole piece, and across the left air gap of the armature. From the armature the magnetic lines of force pass across the right air gap, through the south pole piece and the upper portion of the right yoke to the south pole of the permanent magnet. Magnetic lines of force also pass from the north pole of the permanent magnet, through the lower portion of the left yoke, across the base of the armature at the point where it is clamped, and through the lower part of the right yoke to the south pole of the permanent magnet. The magnetic lines of force attempting to flow downward through the armature are of equal strength to the lines of force attempting to flow upward. Therefore, all lines of force in the armature are canceled, and the armature has no definite polarity. When current flows through the winding in a direction to cause the lines of force in the armature to flow upward, making the top a north pole, the armature will be attracted by the marking pole piece since this pole piece is a south pole due to the permanent magnet. If the current flow is reversed, the polarity of the armature is reversed, making the top a south pole which will be attracted by the spacing pole piece (north). When no current flows in the winding, the armature is centered between the two pole pieces since it has no polarity and the attraction to both pole pieces is equal. A schematic circuit of a WECO polar type relay is shown in figure 33. Usually the bias circuit is opened and only the line winding is used for polar operation. However, the two windings may be connected in series (fig. 33) as is sometimes done in the reperforator for polar operation. This connection can also be used to advantage on polar operation in case of low line current. The polarity of the line current must be as shown to cause the armature to operate to the marking contact.

c. **NEUTRAL OPERATION.** When a 215 or 255 type relay is used as the line relay of a teletypewriter on a neutral circuit, the bias winding is locally supplied with 30 ma of steady current in a direction to cause the armature to be held against the spacing contact. Sixty ma of line current is passed through the line winding in a marking direction. When a marking impulse is transmitted, the magnetic field induced by the 60 ma of line current in the line winding overcomes the magnetic field

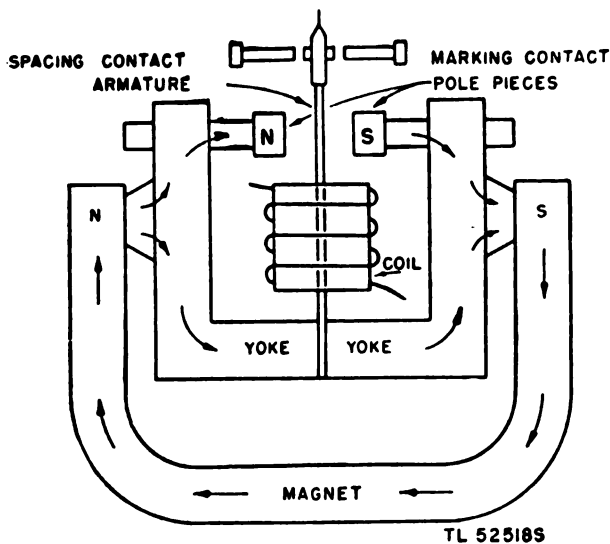

Figure 32. Essential features of the 215 or 255 type polar relay.

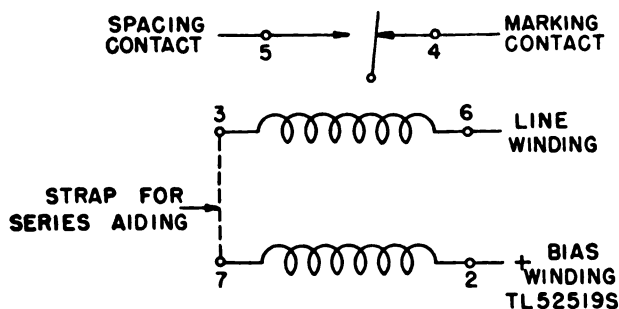

Figure 33. Schematic circuit of the 215 or 255 type relay (polar operation).

induced by the 30 ma of locally supplied current in the bias winding. This causes the armature to move to the marking contact under the influence of an effective force of 30 ma of current through the line winding (60 minus 30). When a spacing impulse is transmitted, there is no current flow in the line winding and the armature is moved to the spacing contact by the 30 ma of current in the bias winding. A of figure 34 illustrates the position of the relay armature when current is flowing in the line circuit (marking impulse). B of figure 34

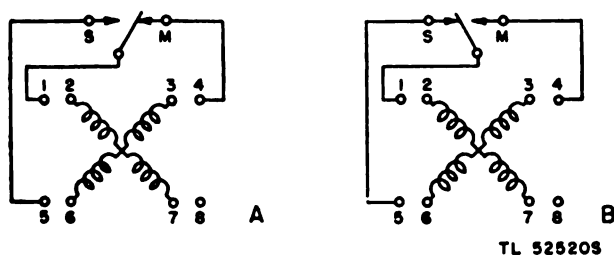

Figure 34. Schematic diagrams of the 215 or 255 type relay (neutral operation).

shows the relay armature when no current is in the line circuit (spacing impulse).

16. Connectors of M-15 Teletypewriter

a. **TERMINAL BLOCKS.** (1) *General.* The wiring of the individual circuits is brought out to terminal blocks on the right side of the machine to enable rapid connection of any type operation or circuit. Figure 35 shows these terminal blocks and their connections. Each terminal is numbered for simplicity; however, in actual practice only one number of each block is stenciled on the terminal casting. Another terminal block is located on the left side of the machine, just beneath the line relay mounting.

(2) *The 20 block (21 to 26 inclusive).* To this block are brought power supply leads for the motor, either alternating current or direct current, at terminals 21 and 23. When relay operation is used, it is necessary to install d-c power on terminals 24 and 25 for the local circuits (bias, magnet, and shunt).

(3) *The 30 block (31 to 36 inclusive).* This is commonly referred to as the send block because the leads from the keyboard transmitter are brought to terminals 32 and 34. Leads from the machine resistance mountings are also brought to this block. These are described in b below.

(4) *The 40 block (41 to 46 inclusive).* This is commonly referred to as the receive block. The outside leads to the receiving mechanism, either relay or magnet, are brought to terminals 41 and 42.

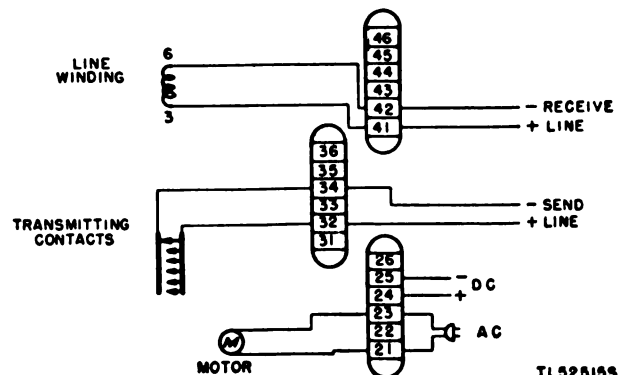
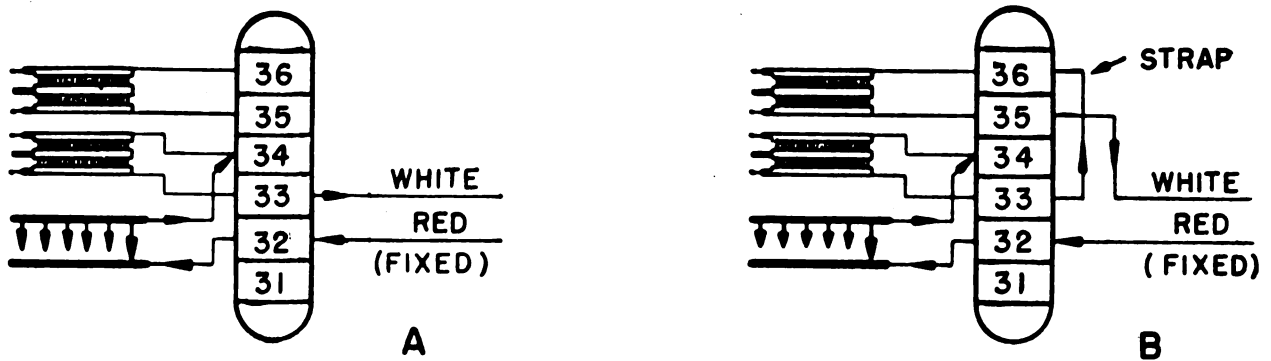

Figure 35. Terminal blocks, 20-30-40.

b. **MACHINE RESISTANCE.** On the rear of the printer base of all military fixed-station type page teletypewriters are two resistance mountings containing two flat-type resistors. The leads from these mountings are brought to the 30 block so that



TL 52514S

Figure 36. Methods of inserting local resistance into line circuit.

they may be inserted into the line circuit to vary the amount of resistance as shown in figure 36.

(1) When no resistance is needed in the circuit, the line conductors are connected to terminals 32 and 34. When one resistor is needed, the white wire is moved from terminal 34 to 33 as shown in A of figure 36. When both resistors are needed, the white wire is moved from terminal 34 to 35, and terminals 33 and 36 are strapped as in B of figure 36. The arrows facilitate circuit tracing.

(2) The flat-type resistors are so constructed that they may be varied from 200 to 1,400 ohms in 100-ohm steps (excluding 1,300). There are three terminals or prongs on each resistor. (See fig. 37.) The part of the resistor that is not required may be eliminated by placing a strap across its prongs. (See B of figure 37.) The 300-ohm portion is not desired; a strap is therefore connected across the two prongs associated with that portion.

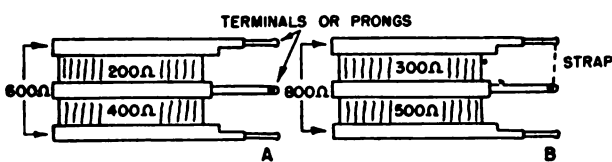

TL 52516S

Figure 37. Flat resistors.

(3) Frequently the vibration caused by teletypewriter operation will cause the resistors to become loose in their mountings and cause an intermittent or permanent open in the transmitting line circuit. A simple method of insuring a solid and permanent contact between the resistor and mounting is to solder a thin wire to each resistor terminal in use and then to fasten the other end of each wire to its respective screw mounting on top of the bakelite insulator of the resistance mounting block.

c. RELAY OPERATION. Usually a teletypewriter will be relay-operated because the relay is able to receive weaker or more distorted signals and retransmit them to the selector magnets in the correct current values. When a teletypewriter is installed on relay operation, a local source of current is required to operate the bias winding and to energize the magnet circuit when the relay armature closes that circuit. On the standard model 15 machine, this local power is conveniently brought in at terminals 24 and 25 on the 20 block. When installing a teletypewriter, it is standard procedure to connect the local power leads before making the line connections. These local power leads are correctly connected when the positive lead is connected to terminal 24 and the negative lead is connected to terminal 25. *Under no circumstances should this polarity be reversed.* If there is incorrect polarity, the current will pass through the relay bias winding in a reverse direction and will consequently pull the armature to the marking side at all times so that spacing signals cannot be transmitted to the receiving-selector magnets and the machine will run permanently closed. The internal wiring of the machine is arranged so that the resistance will divide the current effectively through the various local circuits, provided the local power source is correctly poled and is approximately 115 volts direct current. After the local power is correctly installed, the outside signal line connections are attached to their correct terminals on the machine. The line connections are brought into terminal block 30 (send) and 40 (receive). They may be connected in series or as separate circuits; this depends upon the type of operation desired.

d. DIRECT MAGNET OPERATION. All field teletypewriters are wired for direct magnet operation in the

teletypewriter itself because they are connected to a line unit containing a neutral relay which takes the place of the polar type relay used in the commercial or fixed-station type of machine. In such cases, the line connections will be installed in the same manner as for relay operation, but the local power installation to terminals 24 and 25 will be omitted because the bias, magnet, and shunt circuits are not used. In certain instances, it will be necessary to change a fixed-station type of teletypewriter from relay to magnet operation, or vice versa. In such cases, the wiring changes will be made on the 60 (relay) block, which is located on the left-hand side of the teletypewriter base, beneath the relay-mounting block. Figure 38 shows the changes necessary to install a machine on direct magnet operation. In making the changes as indicated in figure 38, be careful to remove and tape the green wire entering the top of terminal 61, and *not* the green wire entering the terminal from the bottom. These wiring changes bring the internal machine connections to the teletypewriter magnet in series with the line circuit and at the same time open the connections of the line and magnet circuits to the relay. Thus the line circuit travels directly to the teletypewriter magnets and bypasses the relay. (See figs. 42 and 43.)

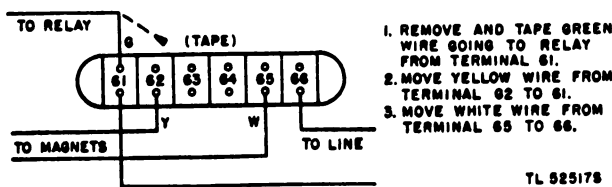

Figure 38. Wiring changes on the 60 block.

e. FILTERS. In cases where teletypewriters are located near sensitive radio equipment, correct filters must be installed on the machines. Some filters which have no effect on high frequencies are designed for use on teletypewriters and, therefore, will not prevent the machine from interfering with radio equipment. These filters, for the most part, are designed to reduce arcing at the contacts and, in so doing, will improve operation and necessitate less contact maintenance. When a monitoring teletypewriter is used with early models of carrier equipment, the filter across the transmitting contacts must be disconnected, because it presents a short to the alternating current used for transmitting at the monitoring teletypewriter. Some filter units designed to reduce arcing at the contacts and improve operation are No. 82018 line relay filter, No. 82019

keyboard contact filter, and No. 81811 power filter. Generally, the filters for radio interference supersede these types. They perform the same functions in addition to radio-interference prevention. The range of effectiveness of the radio-interference prevention filters includes short-wave bands. They also afford better protection for the contacts from the standpoint of wear. Some filter unit assemblies designed for the prevention of radio interference are No. 74983 motor filter, No. 74978 keyboard filter, No. 93884 transmitting contact filter, No. 92227 line relay filter, and No. 102874 power leads filter. Each filter set is accompanied by complete instructions for installation and wiring.

17. Neutral Operation

a. GENERAL. In field installations and in most fixed-station installations operating over short-well-insulated lines, the neutral system of operation is used. This system requires little terminal equipment and is easy to install and operate. Its greatest advantage is simplicity. Generally, it requires very little attention. The chief disadvantage of the neutral system is from the standpoint of teletypewriter signal transmission, because the distortion of signals over the line restricts the length of the circuit. Because of its simplicity, neutral operation is the best system to use unless the circuit is of such length that correct operation of teletypewriter equipment is not possible. Generally, a neutral system will be operated half-duplex; that is, either end can send and receive but not at the same time. Full-duplex operation (each end capable of sending and receiving simultaneously) can be obtained by using two neutral circuits.

b. BATTERY SOURCES. When applying the neutral teletypewriter system to the line, particularly in connection with simplex circuits, certain important precautions are necessary to make transmission over the teletypewriter circuit satisfactory and at the same time keep interference into the telephone circuit at a minimum. The nominal line current on all neutral circuits should be 60 ma direct current and where the teletypewriter circuit is simplex on a telephone line, it should not be allowed to exceed 75 ma in any case. To obtain line current, a source of direct current must be connected at one end of the circuit. This power may be supplied from commercial or military sources of alternating current at various voltages by means of rectifiers. D-c gasoline engine generator sets or other d-c power sources may be used. In actual practice it

may be necessary to add more voltage to the line circuit because of high resistance. Do this by adding a series-aiding rectifier at the end normally supplying line current. The series-aiding rectifier is also used in case of high leakage. If a relay is used in the teletypewriter, local power of 115 volts is necessary for the bias, shunt, and magnet circuits.

c. ONE-WAY OPERATION. One-way operation, though seldom used by the Army, may have to be installed by the teletypewriter mechanic at some outlying station. If this type operation is desired with a page-printing unit at the receiving-only station, usually the M-15 receiving and printing unit will be used. This model is installed exactly as a regular M-15, except that there are no transmitting contacts to be connected in series with the line at the receiving-only station.

d. HALF-DUPLEX OPERATION. In half-duplex operation only one machine at a time can be used to send to the other machine or machines in the circuit. Because the opening and closing of the line circuit by the transmitting contacts control the operation of the teletypewriters, the sending and receiving circuits of each must be in series with every teletypewriter in the circuit. Figure 39 shows the line, bias, and magnet circuit connections of a two-station neutral teletypewriter circuit on half-duplex operation. The line circuit may be traced from positive battery at station A to terminal 32 (positive), through the transmitting contacts, and back to terminal 34 (negative). This completes the line circuit through the transmitting mechanism of the station A teletypewriter. To place the transmitting contacts in series with the receiving relay of this station, a strap or jumper is placed from terminal 34 to terminal 41. From this point the circuit continues through the line winding of the relay to terminal 42 and completes the series line circuit through both the transmitting and receiving mechanisms of the station A teletypewriter. The circuit continues over the line to terminal 32 of the station B teletypewriter, through the transmitting contacts to terminal 34, through the jumper to terminal 41, then through the line winding of the relay to terminal 42 to complete the series connections of the transmitting and receiving mechanisms of station B. The circuit returns through the line to the negative side of the battery at station A. Note the following points:

(1) The line circuit is not connected electrically in any way with the relay armature or the magnet or bias circuits of either station.

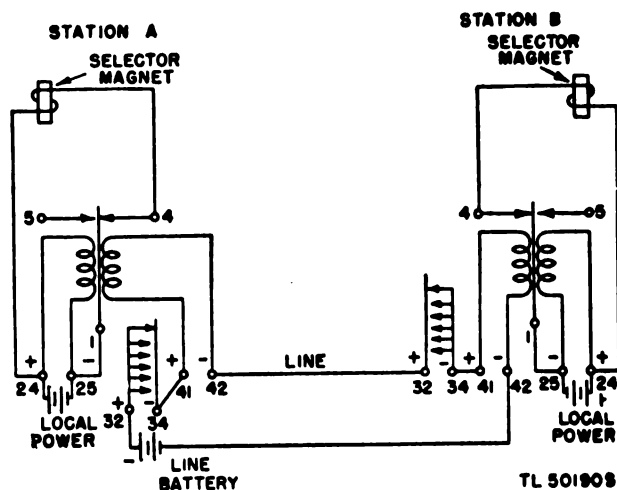

Figure 39. Two-station neutral half-duplex circuit.

(2) Positive battery is always connected to the positive terminal (41) of the line winding, and negative to the negative terminal (42). This will cause the relay armature to move to the marking side when current flows through the line winding of the relay.

(3) The line and battery terminals should be connected to the correct terminals at all times, even though the polarity, when direct magnet operation is being used, will not affect the operation of the teletypewriter. Thus terminals 32 and 41 are positive, and terminals 34 and 42 are negative at all times.

(4) The only resistance shown in the circuit is the resistance of the line wires between stations and the resistance of the line windings of the relays. Since this total resistance may be small, additional resistance may have to be inserted to limit the value of the line current to 60 ma. If three or more teletypewriters are connected for half-duplex operation in a neutral circuit, the same principles as stated above will apply. Figure 40 shows the line connections of three teletypewriters in a half-duplex, neutral circuit.

e. FULL-DUPLEX OPERATION. Full-duplex operation is possible over neutral circuits and will enable simultaneous sending and receiving. This is made

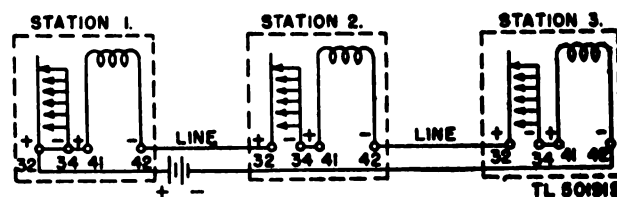

Figure 40. Line connections of three teletypewriters on half-duplex operation.

possible by connecting two line circuits, each separate from the other, and each having its own individual source of current supply. The transmitting unit of one machine is connected in series with the receiving unit of the other machine to complete one circuit with its own battery source. The receiving unit of the first machine is connected in series with the sending unit of the second machine with another battery source to form the second circuit. Figure 41 illustrates this method of installation and shows two teletypewriters on neutral full-duplex operation. This permits each to send and receive simultaneously, but neither machine will receive home copy because the transmitting line is connected only to the receiving unit of the other teletypewriter. The basic principles as to polarity, power supply, and addition of necessary resistance that apply to half-duplex operation also apply to this method. The following points should be remembered in making installations for full-duplex operation over a neutral system:

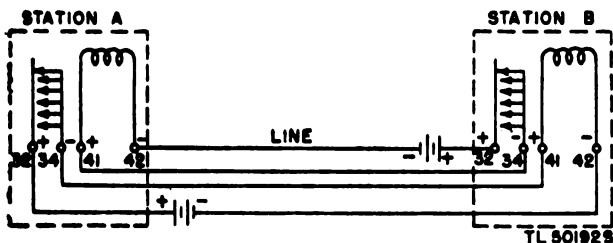

Figure 41. Connections for full-duplex operation.

- (1) The circuits are two separate and distinct line circuits, not connected to each other in any way.
- (2) Battery for each line circuit should be supplied at the transmitting station. In this way the line current can be controlled easily by inserting flat-type resistors into the signal line. These are wired to the transmitting block.
- (3) Home copy, a very desirable feature, is not obtained.

18. Polar Operation

In polar operation, because the relay works on a reversal of current instead of an opened and closed line circuit, the relay biasing circuit must be disconnected. This is normally done by depressing the polar-neutral key. Because the transmitting contacts can send only neutral signals, the machine must be connected for either full-duplex (which will permit the machine to receive polar and transmit neutral signals) or one-way (receive only) operation. Usually, when polar signals on the line are desired,

the machine will be connected for neutral operation and will work in conjunction with a repeater or other pole-changing equipment.

Section IV. GENERAL FUNCTIONS OF REPEATERS AND SWITCHBOARDS

19. Interconnection of Circuits

Both military and civilian teletypewriter systems require the use of many different combinations of the various types of circuits discussed in preceding sections of this manual. The interconnection of the different types of circuits involves the use of specially designed electrical repeaters which change the signals (impulses) received from one type of circuit into the type of signals required for transmission in another type of circuit. Figure 44 illustrates the use of a telegraph repeater located at an intermediate point between two stations to connect the neutral type circuit at one end to the polar type circuit at the other end. With such an arrangement the neutral type signals leaving station A travel only as far as the telegraph repeater where they are changed into polar type signals which travel on to station B. Transmission in the opposite direction is accomplished when the repeater changes the polar type signals received from station B into neutral type signals that travel on to station A. The same general arrangement permits the use of polarential type operation in place of polar. An explanation of the circuits and the more commonly used equipment to accomplish interconnection of circuits as described above is given in later sections of this manual.

20. Using Two Repeaters

In some tactical military teletypewriter systems the stations will send and receive only neutral type signals. For these systems two repeaters will be required when the circuit between the stations is designed for polar type signals. Figure 45 illustrates the use of two terminal repeaters connected by a polar circuit arranged so that each station sends and receives neutral type signals. The terminal repeaters are normally located very close to the associated station. However, they function in the same manner regardless of their location or the length of the different types of circuits. In all cases the neutral type signals leaving station A travel only as far as the nearest repeater. There they are changed into polar type signals for transmission to

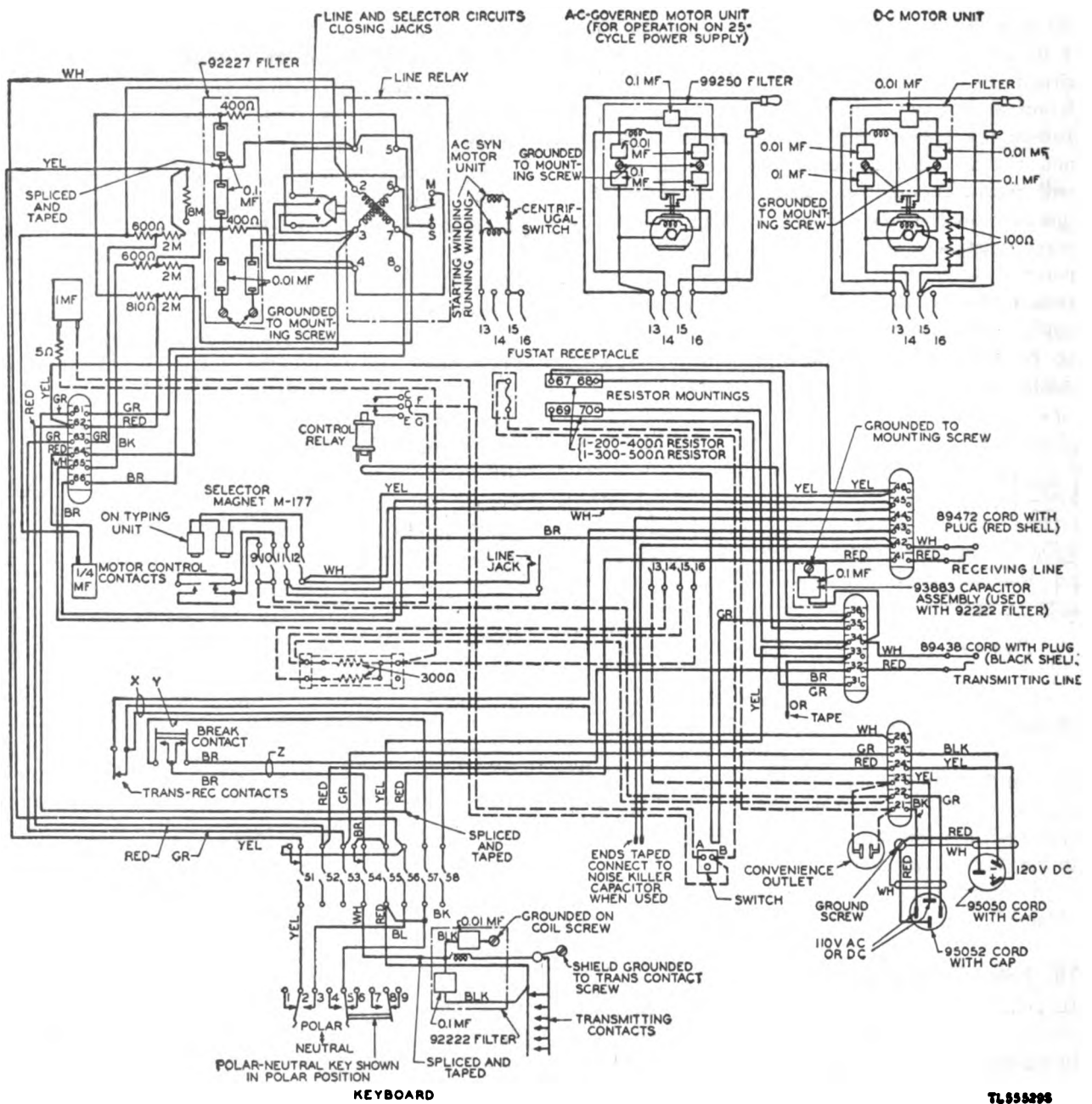

Figure 42. Model 15 teletypewriter set with keyboard, actual wiring diagram.

TL555298

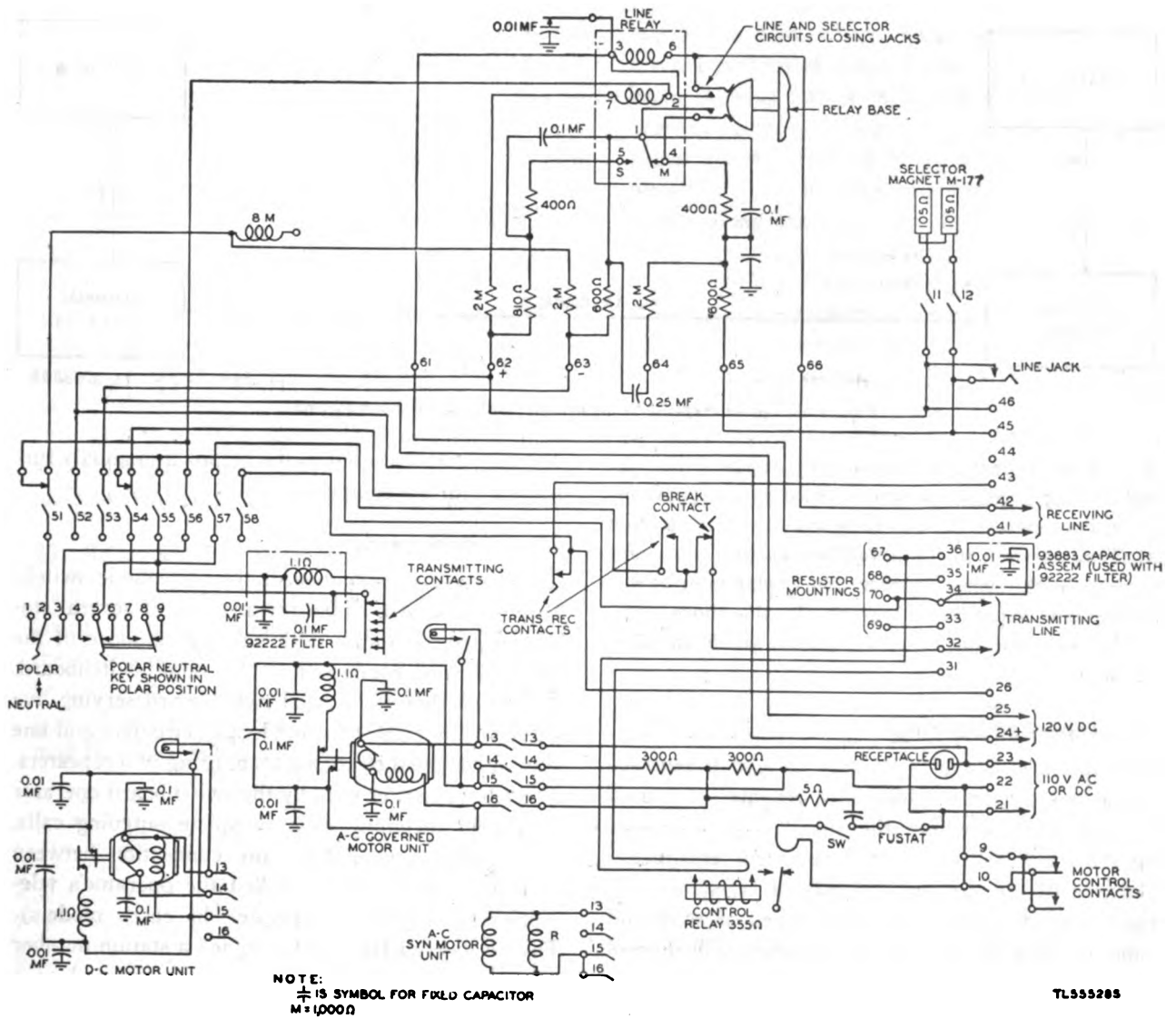

Figure 43. Model 15 teletypewriter set with keyboard, schematic wiring diagram.

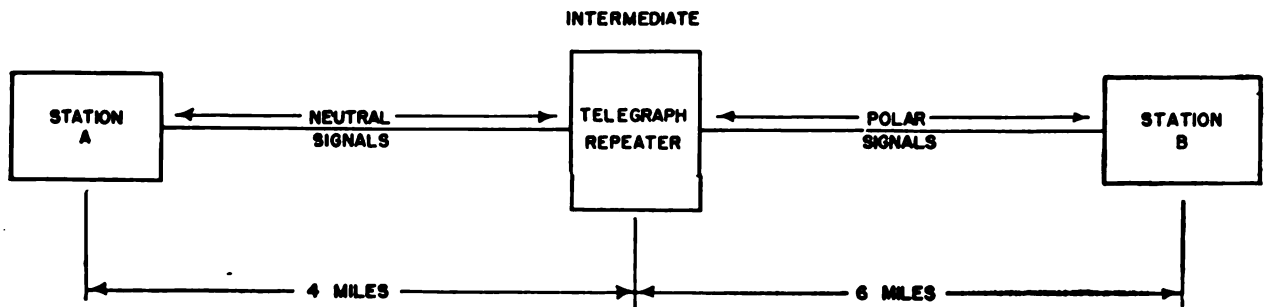

Figure 44. Repeater connecting neutral and polar circuits.

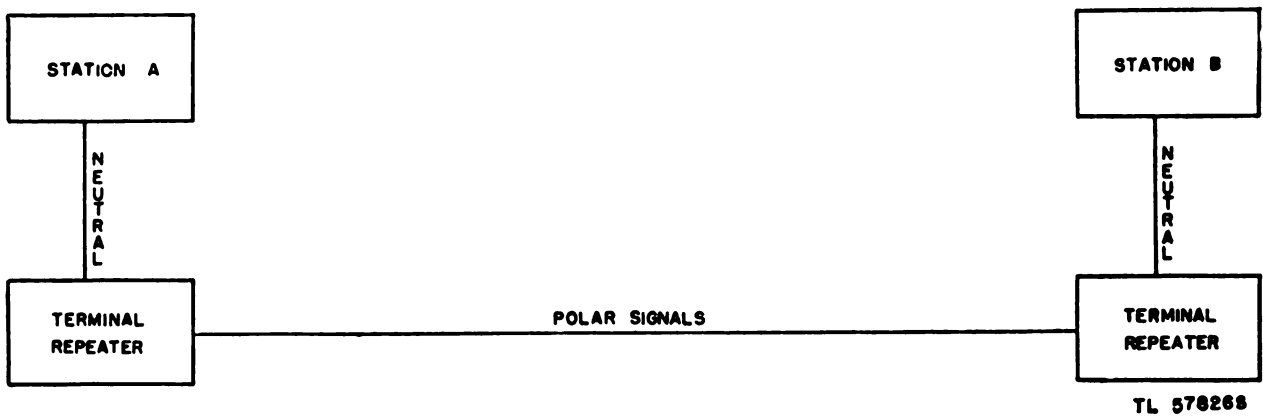

Figure 45. Two repeaters connecting stations on polar circuit.

the distant repeater. At the distant repeater the signals are changed back into neutral type signals required to operate the receiving equipment at station B. Transmission in the opposite direction is accomplished in the same manner. An explanation of the circuit and equipment features in the more commonly used terminal repeaters is given in later sections.

21. Repeater Spacing

In addition to changing the type of signals required in various circuit combinations, repeaters are used in long circuits where the signals will otherwise be too weak to operate the receiving equipment. Because of the varying amounts of resistance, capacitance, etc., in the different types of wire and cable circuits, the spacing of repeaters will depend upon both the circuit loss in signal strength and the capabilities of the repeaters used. Information concerning the correct spacing for each type of

repeater will be found in the technical manuals furnished with the equipment.

22. Switchboards

Teletypewriter switchboards, like telephone switchboards, make it possible for any one of several stations to communicate with any one or more of the other stations connected to the same switchboard. Figure 46 shows a typical switchboard serving five stations connected by short loops (circuits) and one station connected by a long loop, using two repeaters. The teletypewriter used by the switchboard operator to answer incoming calls, complete outgoing calls, and supervise (monitor) any connection between two or more stations is called the operator's teletypewriter (operator's printer in early models). This teletypewriter is not assigned a station number or discussed in later sections of this manual as a station, although in general the teletypewriter itself functions in the same manner as other teletype-

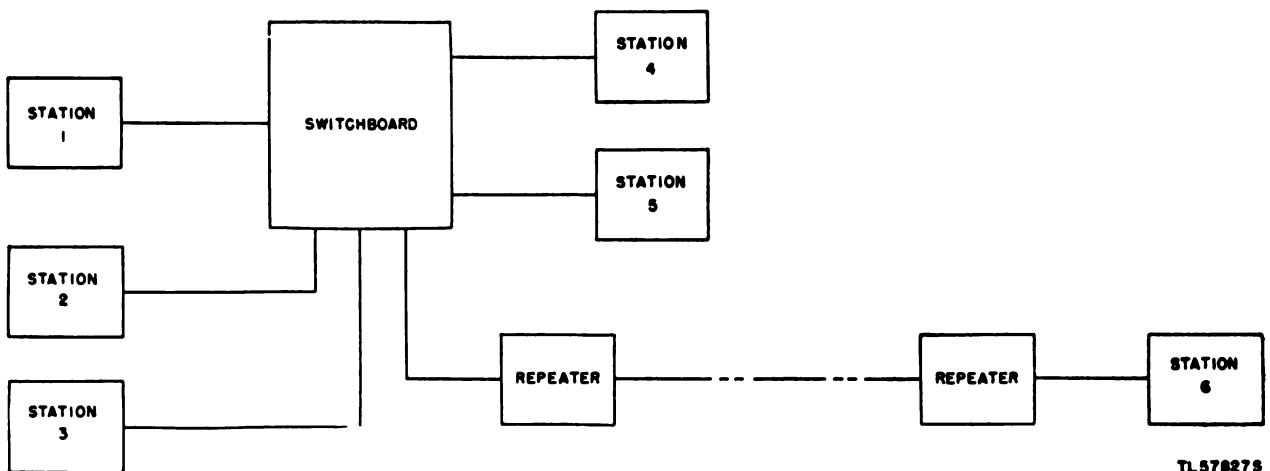

Figure 46. Switchboard serving five stations on short loops and one station connected by a long loop.

writers connected to the switchboard as stations. Although both military and commercial teletype-writer systems use many different switchboard arrangements, the circuit connecting each station to its associated switchboard is normally called a *local* or *local loop*, and the circuit connecting the two switchboards is called a trunk. The type of circuit operation used such as neutral, polar, polarential, carrier, or radio channel does not change the designation of the circuit as either a LOCAL (station loop) or trunk, depending upon its use between a station and switchboard or between two switchboards. A more detailed explanation of the basic circuits required to call the operator, call the station, furnish a disconnect signal, operate a night alarm, and other functional features of tactical and fixed plant switchboards are furnished in later sections.

23. Regenerative Repeaters

Each time the signals have passed through a switchboard or intermediate and terminal repeaters of the type already described, the signals are liable to be distorted. To overcome this distortion, a special type of repeater known as a regenerative repeater may be connected in a long, complex circuit to cor-

rect for the distortion that may otherwise accumulate to the point where the distant station will receive a garbled message. Figure 48 is a block diagram showing how a regenerative repeater is used near the center of a long, complex circuit to improve signal quality. The signal leaving station A is repeated by the switchboard numbered 1. As the signal travels along the circuit to the repeater numbered 2 the signal becomes weaker, but at the repeater it is strengthened, and again repeated, and continues along to the regenerative repeater. By the time it arrives at the regenerative repeater numbered 3 it has become considerably distorted. The regenerative repeater removes the distortion and the signal proceeds along the circuit to the repeater numbered 4 in the diagram. This repeater, like the repeater numbered 2, strengthens the signal, repeats it, and sends it along to the switchboard numbered 5 where it is again repeated and transmitted to the teletypewriter at station B. Figure 49 shows how the signals leaving the regenerative repeater have been corrected as compared with the distorted signals received. An explanation of the circuits and equipment found in the more commonly used regenerative repeaters is given in a later section of the manual.

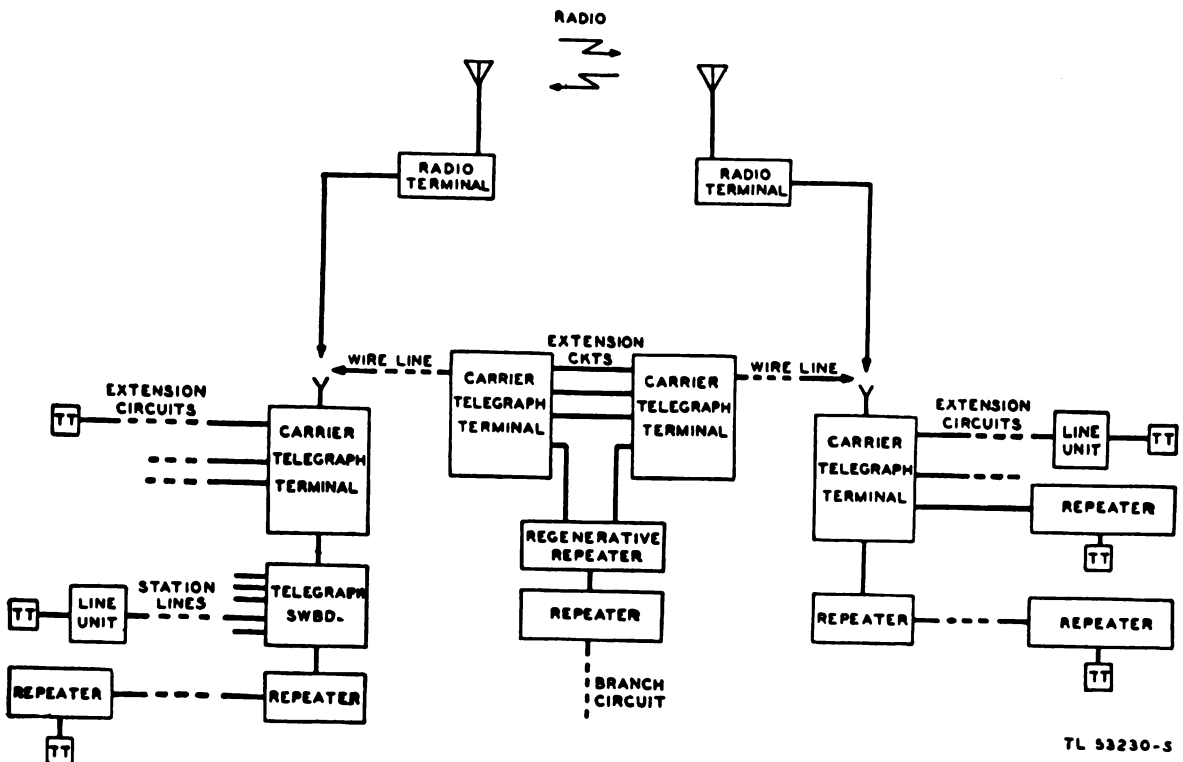

TL 53230-5

Figure 47. Teletypewriter system with wire (d-c and carrier) and radio transmission circuits.

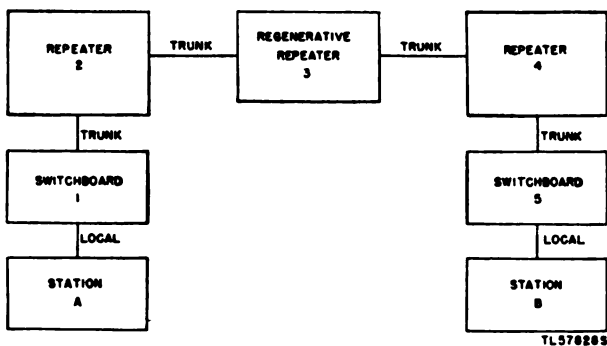

Figure 48. Relative position of regenerative repeater in long, complex circuit.



Figure 49. Distorted signals corrected by regenerative repeater.

24. Connection of Military Teletypewriter System to Commercial System

a. Sometimes it is necessary to connect military teletypewriter systems to commercial teletypewriter

systems. Commercial systems using polar type signals cannot be connected directly into military neutral signal switchboards. Specially designed relay units or repeaters in combination with certain types of military switchboards provide the means for making such connections inasmuch as they are capable of receiving polar communication signals from the commercial line and repeating them as neutral signals to the switchboard and vice versa. Generally this type of relay unit provides one circuit to a commercial or TWX switchboard. When the traffic load requires it, more than one relay unit may be used with a teletypewriter switchboard. Figure 50 is an application schematic diagram which indicates the equipment involved in an over-all circuit between an Army teletypewriter switchboard and a TWX switchboard. Sometimes included with this type of relay or repeater is equipment which permits the operator at the military switchboard to signal, receive signals, and monitor.

b. Figure 51 is a functional chart showing applications of Signal Corps telegraph and teletypewriter equipment connected to a commercial system and including provision for the use of some foreign teletypewriter equipment.

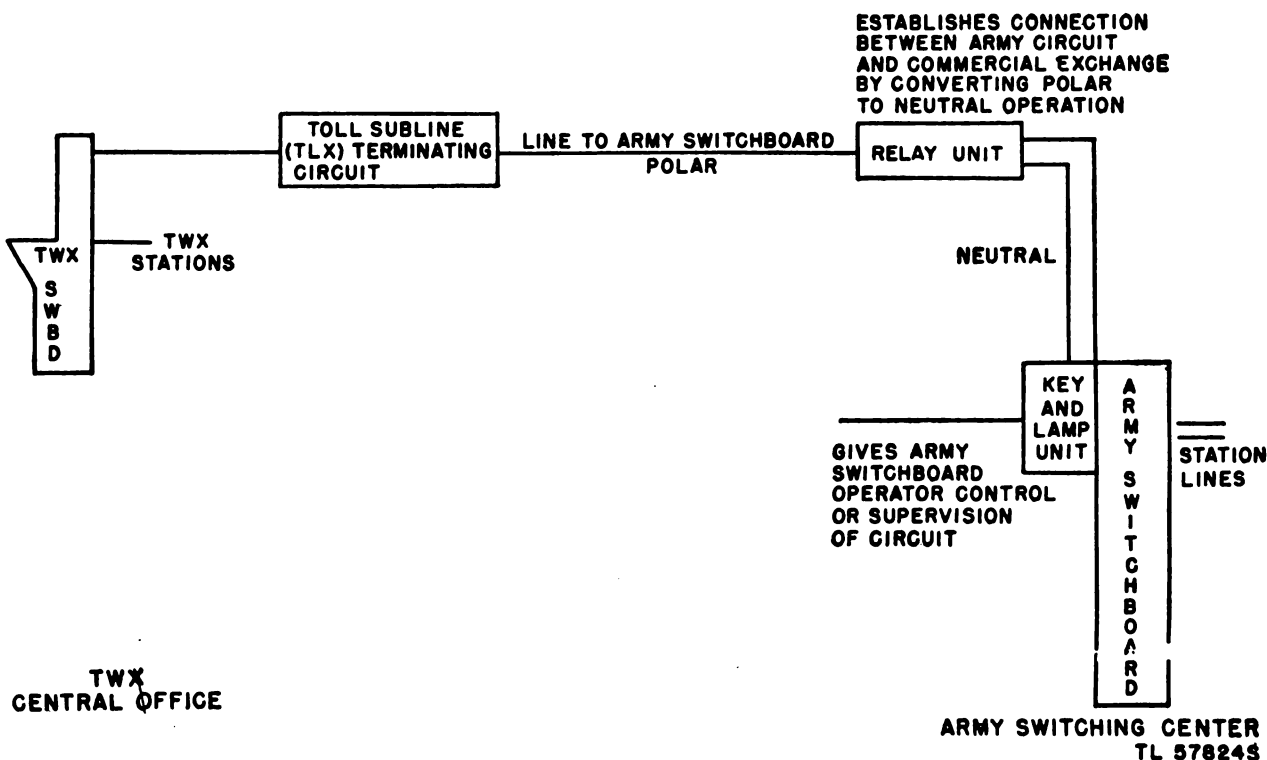

Figure 50. Military teletypewriter switchboard connected to TWX system.

CHAPTER 2

TELETYPEWRITER EQUIPMENT FEATURES

Section I. EQUIPMENT CONNECTIONS

25. General Introduction

Military installations of teletypewriters are divided into two classifications: Fixed or permanent, and field or mobile. Fixed station installation means exactly what the term implies: the teletypewriter equipment is installed in a standard manner on a permanent or semipermanent basis. For this reason, the utility of the apparatus installed and conservation of space and wiring connections must be considered. The teletypewriter mechanic must not only be thoroughly familiar with the teletypewriter tables, rectifiers, terminals, plugs, and jacks used in permanent practice, but he must know how best to install this equipment, how to run the wires and cables so that the complete installation will be neat, compact, and convenient for both operation and maintenance.

26. Use of Jacks, Plugs, and Cords

a. GENERAL. The method that has been adopted as the quickest and most convenient for installing the lines is the termination of each line circuit in a jack wherever possible. Connections are then made from the machine to these jacks by means of plugs and cords. All teletypewriter tables in military installations have line jacks to which the signal lines are connected instead of joining them directly to the machine terminal blocks.

b. JACKS. There are a number of jacks used in teletypewriter installations, each type usually performing a different function. The jacks used are usually of the break-one or break-two types, and when the break occurs from the tip spring, they are called single cut-off or double cut-off jacks. When a plug is inserted into the jack of A in figure 52 the tip of the plug will bear against the tip of the jack, forcing it to rise, and open or cut off the lower contact. Because this one contact is cut off, the jack is called a single cut-off jack. If a plug were inserted into the jack in B of figure 52, the

tip of the plug would cause the tip spring of the jack to rise and, because the tip spring is connected to a strip of insulation, it would also cause the top spring to rise. The plug, then, will cause both springs to rise and open their normally closed contacts. Therefore, this jack is called a double cut-off jack. At the same time, the abrupt shoulder of the plug goes against the sleeve of the jack and completes the other part of the circuit. Line circuits terminate in jacks in teletypewriter tables and switchboards because the jacks furnish an easy and rapid method of making connections to the line circuits.

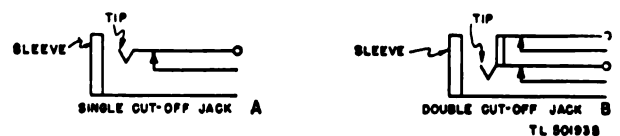

Figure 52. Schematic diagram of jacks.

c. PLUGS AND CORDS. For making connections to the teletypewriter equipment, plug-ended cords are generally used. These cords consist of a pair of conductors terminated in a plug at one end and terminal clips at the other end, the plug for connection to the jack and the terminal clips for connection to the machine terminals. The plug consists of three main parts: A rod terminating in a ball, a tube fitted over the rod and insulated from it, and a shell which covers the rear end of the rod and tube and protects the connections of these parts of the cord. Figure 53 shows a plug in cross section. The ball is known as the tip and makes contact with the tip spring of the jack, while the tube is known as the sleeve and makes contact with the sleeve of the jack. Figure 54 shows a plug

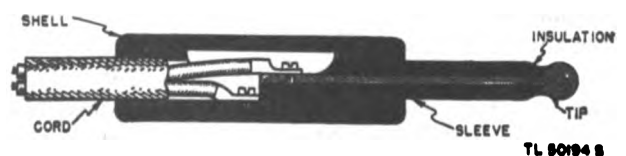

Figure 53. Cross section of a two-conductor plug.

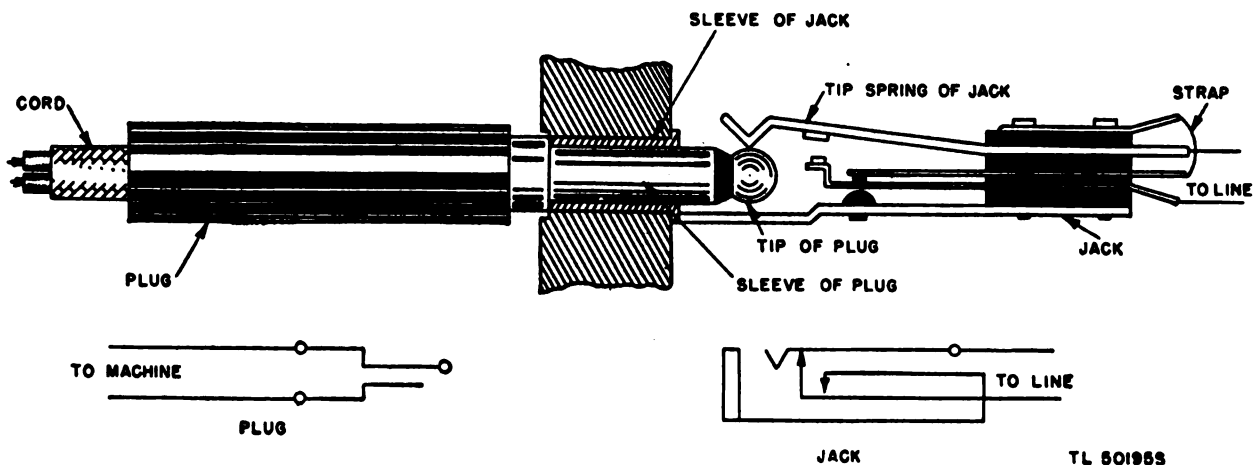

Figure 54. Teletypewriter plug and jack.

inserted into a jack that is commonly used in teletypewriter tables. The symbol for each is shown in the same figure. It will be seen from this diagram that the tip of the plug makes contact with the sleeve of the jack. This type jack differs from those previously explained in that, when the plug is inserted, it opens a pair of contacts that are normally closed and closes a pair of contacts that are normally open. This type is known as a make-one, break-one jack. Because of the two pairs of contacts, the signal line circuit will be closed regardless of whether the plug is in or out. The screws that hold together the entire spring assembly also are conductors for the sleeve part of the circuit. In teletypewriter circuits, negative battery is always connected to the tip when jacks are used. By variations in the number and arrangement of the springs, a jack can be made to perform simple switching operations when the plug is inserted.

27. M-15 Teletypewriter Tables

Special teletypewriter tables designed for the different teletypewriter units or for a combination of different units are available. Tables XRT-97 and XRT-106 are especially designed to support the M-15 teletypewriter, its rectifier, and the associated cords, receptacles, and terminals. These two tables differ only in minor changes of construction and wiring. Both tables are constructed of steel with a black wrinkle finish. They mount a number of receptacles for the electrical connection of associated equipment, two pairs of send-receive jacks, and terminals for making the desired signal line connections. Both are provided with a built-in shelf for mounting a rectifier without interfering with the operator's leg-room.

a. DIFFERENCES. Tables XRT-97 and XRT-106 differ in both mechanical and electrical features.

(1) The electrical differences are: The self-contained local test circuit in XRT-106 (the XRT-97 local test circuit must be wired externally) and a table ground screw on the XRT-106 which is not found on the XRT-97.

(2) The physical differences are the two plates used to reduce vibration on the top of table XRT-106 on which the base of the teletypewriter rests, the arrangement of the receptacles and send-receive jacks under the two tables, and the absence of the two three-post terminal blocks under table XRT-106. (See figs. 55 and 56.)

b. CONNECTIONS OF TABLES XRT-97 AND XRT-106. The electrical connections mounted under these tables consist of two pairs of send-receive jacks, receptacles A, B, and C, plug D, and terminals for signal line connections. Figures 69 and 70 are wiring diagrams of tables XRT-97 and XRT-106 and should be used with the following description. For location of all connections, refer to figures 55 and 56.

(1) *Receptacle A.* This polarized two-wire receptacle provides an outlet into which the a-c supply line to the teletypewriter rectifier may be plugged. When the rectifier is not used, as in the case when an external source of 110-volt d-c power is available, the receptacle is not used.

(2) *Receptacle B.* This polarized four-wire receptacle receives the four-wire plug on the cord, the other end of which connects to the teletypewriter base terminals Nos. 21, 22, 23, and the teletypewriter ground screw. The power leads to

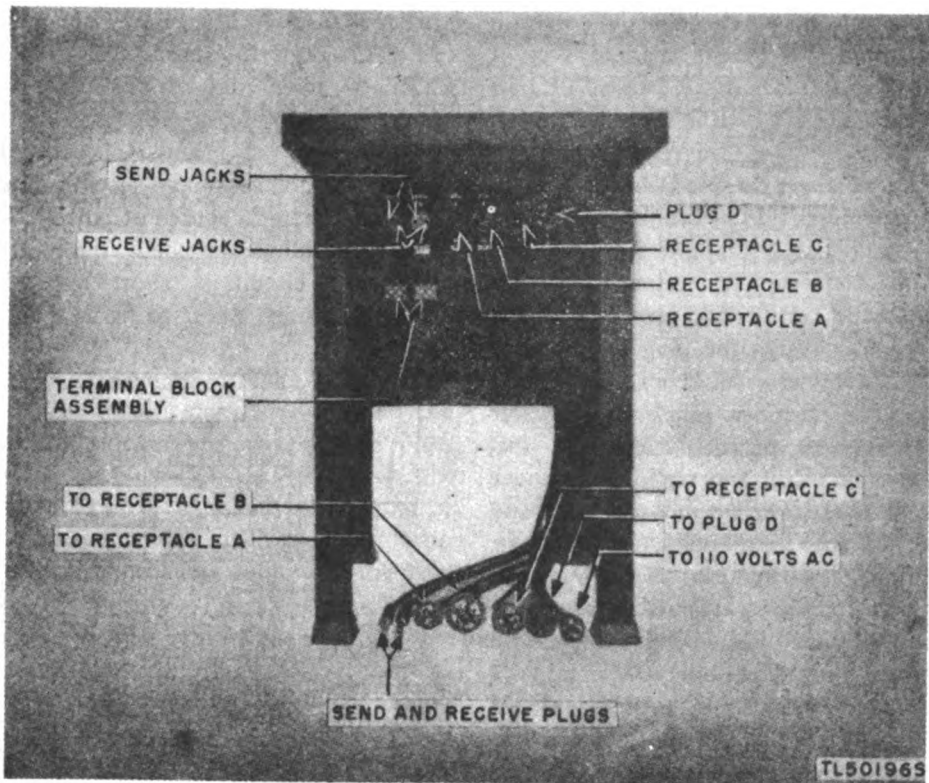

Figure 55. Table XRT-97.

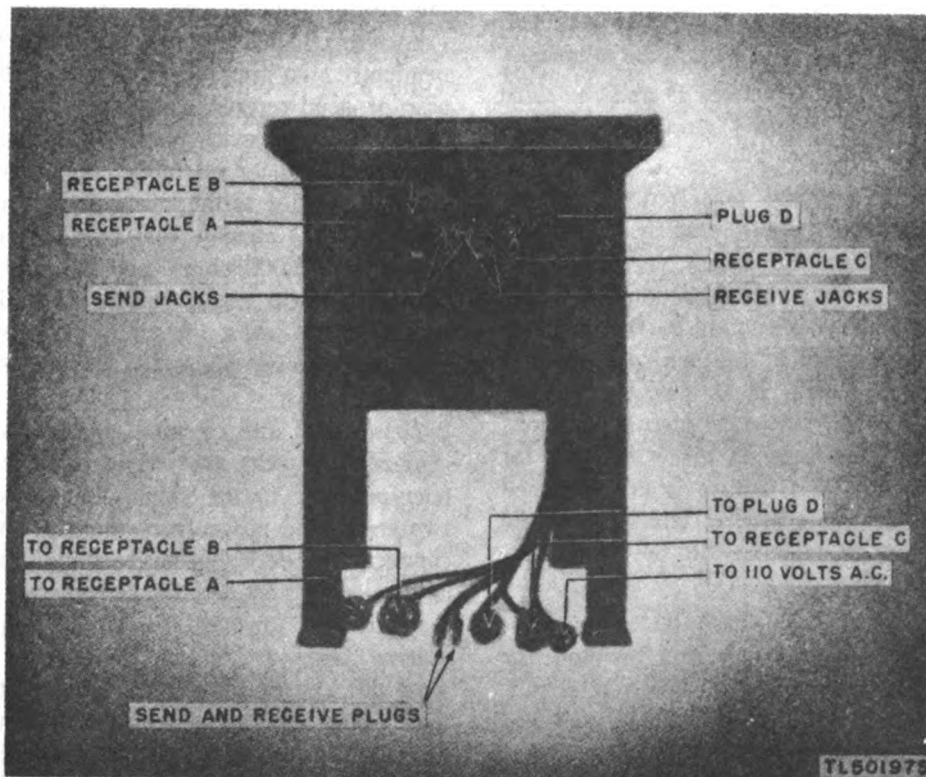

Figure 56. Table XRT-106.

this receptacle are brought up through the porcelain bushing and connected to points marked Nos. 1 and 2 on the diagrams. THESE CONNECTIONS ARE ALWAYS USED REGARDLESS OF WHETHER A-C OR D-C POWER IS SUPPLIED. When d-c power is used, be careful in wiring that the grounded side is connected to point 2. See table of connections in figures 69 and 70. Points 2 and 3 are connected to receptacle A which supplies power to the rectifier. It may be seen by following the circuit through the plug and cord to the teletypewriter terminal No. 22 and completing the circuit, that the rectifier and teletypewriter motor are connected in parallel. Note also that both the teletypewriter motor and rectifier are under the control of the teletypewriter motor switch and the protection of the fuse on the teletypewriter base. On the XRT-97 table, a wire from an earth ground is brought to point 4 and this ground, through its various connections, effectively grounds the entire assembly including the table, teletypewriter, and rectifier. On the XRT-106 table, a table ground screw is provided with a connection already made to point No. 4. A wire from an earth ground to this ground screw will effectively ground the entire assembly.

(3) *Plug D.* This polarized three-wire plug is used only when the rectifier is used as a source of d-c power. Two of the connections on the plug supply the d-c power to receptacle D and the third connection carries the rectifier protective ground wire.

(4) *Receptacle C.* This polarized three-wire receptacle receives the three-wire plug through which the direct current for local power is supplied to the teletypewriter terminals Nos. 24 and 25. This also carries a ground connection to the teletypewriter ground screw which, in turn, grounds the rectifier through receptacle B as discussed above. On the XRT-106 table, a parallel circuit is tapped from this receptacle to provide direct current for the local test circuit. This feature is not provided on table XRT-97. To adapt these tables to various power supplies, see instructions in the table connections in figures 69 and 70.

(5) *Local test circuit.* On each table, a pair of send-receive jacks provides a simple method for connecting the teletypewriter to a local test circuit. Two plugs with cords attached (black for send, red for receive) are used to connect the teletypewriter to the local test circuit or signaling circuit as desired. **WHENEVER POSSIBLE, TEST ALL EQUIP-**

MENT LOCALLY BEFORE CONNECTING IT TO THE SIGNALING CIRCUIT. On the XRT-97 table, the left-hand pair of send-receive jacks is for local test. The jacks are wired to terminal screws Nos. 1 and 2 (counting from left to right) on the terminal block assembly. For this local test circuit a source of power must be included. When the plugs are not in the local test jacks, the local test circuit is short-circuited by the jack contact springs. Refer to figure 57.

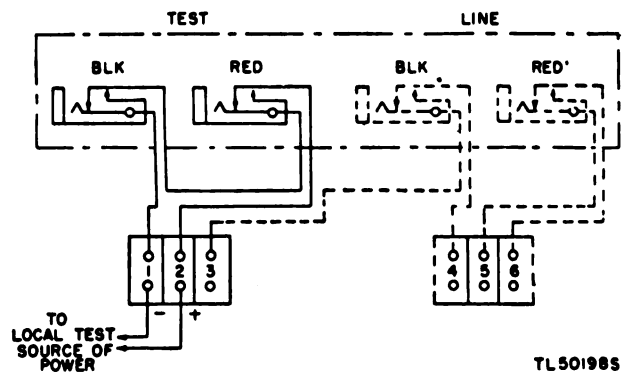

Figure 57. Local test circuit of table XRT-97.

This feature permits one local circuit to supply any number of local machines and also permits the sending circuit (black plug) and the receiving circuit (red plug) to be plugged into the test circuit independently. On the XRT-106 table, the right-hand pair of send-receive jacks are for local test. (See fig. 58.) These jacks, instead of being connected to a terminal block assembly, are wired through a variable resistor to the local power supply on receptacle C. The variable 2,500-ohm resistor must be adjusted to 2,000 ohms, plus or minus 10 percent, before the local test circuit is used. Because of the action of the jacks, the circuit is open unless both send and receive plugs are in the test jacks. (See fig. 58.)

(6) *Signal line circuit.* On each table a pair of send-receive jacks are provided for connecting the teletypewriter to the signal line circuit. The same two cords and plugs from the machine are used to connect the teletypewriter to the signal line circuit, as are used to connect the teletypewriter to the local test circuit. However, the signal line circuit send-receive jacks are wired differently than are the local test circuit send-receive jacks. It may be seen from figure 59 that the send and receive circuits are not inter-connected at the jacks and that each jack short circuits its corresponding circuit if the plug is removed from the jack. On the XRT-97 table,

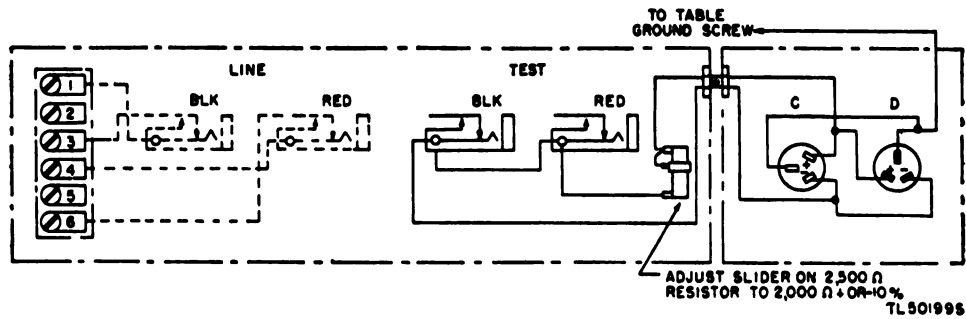

Figure 58. Local test circuit of table XRT-106.

the send jack is connected to terminal screws Nos. 3 and 4 of the terminal block assembly and the receive jack is connected to terminal screws Nos. 5 and 6. (See fig. 59.) On the XRT-106 table, the send jack is connected to terminals Nos. 1 and 3, and the receive jack to terminals Nos. 4 and 6 on the fiber terminal strip which is located at the rear of the jack mounting plate. (See fig. 59.) (It is necessary on table XRT-106, to remove the jack mounting from its housing to install the line signal wires to this terminal strip.) If it is desired to operate half-duplex, a strap is connected between terminals 4 and 5 on the XRT-97 table and terminals 3 and 4 on the XRT-106 table. This strap connects the line relay of the machine in series with the transmitter contacts. The signal line is then connected to 3 and 6 on the XRT-97, and 1 and 6 on the XRT-106 table. When the plugs are in the jacks on either table (fig. 59), a simple series circuit is arranged. Beginning with terminal

No. 6, the circuit follows the path through the make contact and sleeve of the receiving jack to teletypewriter base terminal No. 41, and through the relay winding to teletypewriter base terminal No. 42. From here, it follows the tip circuit of the jack through the strap on the table terminals to the teletypewriter base, terminal No. 32, through the transmitter contacts and terminal No. 34, over the tip circuit of the jack to the other signal line terminal on the table terminal mounting. For full-duplex operation, four wires are connected to the teletypewriter table, two wires for the send leg (terminals 3 and 4 on the XRT-97, 1 and 3 on XRT-106) and two wires for the receive leg (terminals 5 and 6 on the XRT-97, 4 and 6 on XRT-106). The strap connecting the transmitting contacts and the line relay in series must be removed in this type of operation. A ground-return circuit may be used for the send, receive, or for both circuits. A SEPARATE SOURCE OF

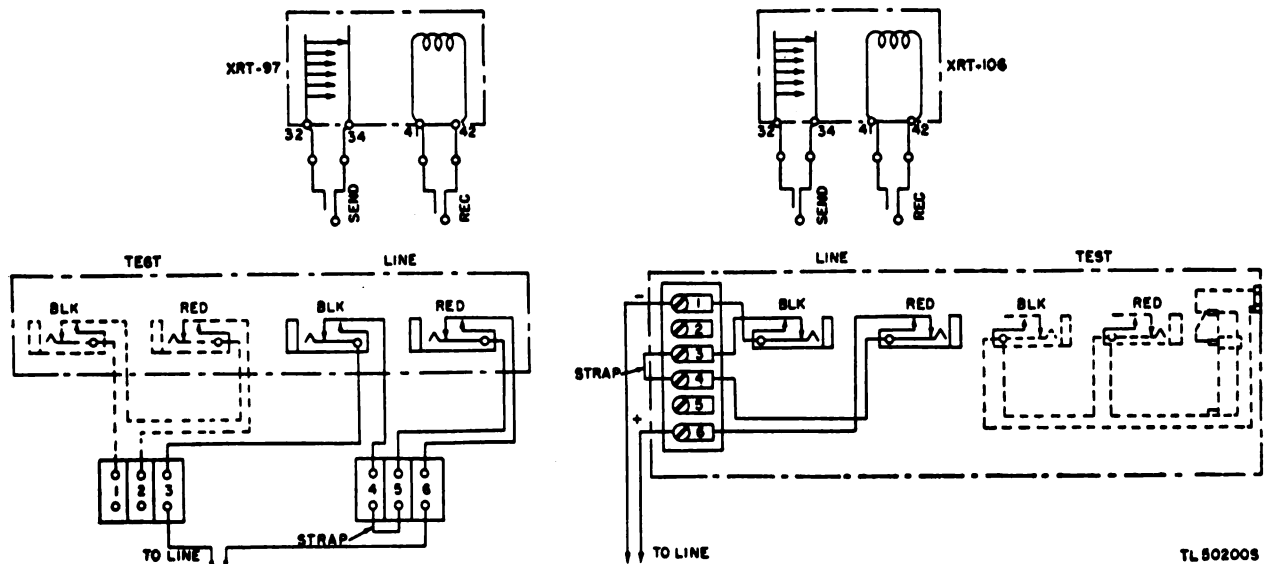

Figure 59. Signal line connections for tables XRT-97 and XRT-106.

DIRECT CURRENT MUST BE CONNECTED IN SERIES WITH EACH OF THESE SEPARATE CIRCUITS. Normally, in a full-duplex arrangement, power is supplied at the transmitting end of each circuit to enable control of the line current at its source by means of the resistors in the teletypewriter base.

28. M-19 Teletypewriter Tables

a. GENERAL. Tables XRT-96 and XRT-107 are metal tables especially designed to support the M-19 composite set and the necessary cords, terminal strips, switches, and receptacles. The two tables differ in a minor change of construction. Unlike the M-15 teletypewriter tables, the connections are made and the rectifier installed at the rear of the tables; therefore, it is necessary to have access to the rear of the table not only for installation, but also for maintenance and inspection.

b. DIFFERENCES. The constructional differences between tables XRT-96 and XRT-107 are the two plates mounted on the top of table XRT-107 upon which the base of the teletypewriter rests. These plates are used to reduce vibration. They are not found on table XRT-96.

c. CONNECTIONS. (1) *General.* The electrical circuits of the two M-19 tables (XRT-96 and XRT-107) are identical and were thoroughly covered in conjunction with the model 19 composite set. Therefore, the following paragraphs cover only those connections and modifications that are pertinent to the installation of these tables on a signal line or lines. Figure 71 is for reference on all descriptions. The table of connections in figure 71 contains all the instructions necessary for making or changing connections to accommodate any source of power that may be used. The recommended fusatron protection is indicated in another table in the same figure. The M-19 tables are wired to accommodate almost any type of operation or circuit. For example, figure 71 is a schematic diagram of the M-19 composite set plus a reperforator. When all connections from the outside duct are used, several conditions are established: The keyboard and the relay are independent of all the rest of the set. Two lines are connected for the reperforator. The transmitter distributor may be used on either line No. 1 or line No. 2, depending on the position of the switching key lever. The test circuit is available if desired and may be connected to other local equipment with power supplied either within the table or from an external source. All of

the signaling circuits or line connections should be run through an outside duct and connected to the terminals on the terminal strip C, D, and E. These connections are changed (fig. 71) to accommodate different circuit arrangements.

(2) *Teletypewriter send circuit.* The teletypewriter send line connection for full-duplex transmission (dotted lines), when desired, is run to the table through the outside duct and connected to terminals Nos. 1 and 2 on terminal strip C. These two terminals are made available by disposing of the wires indicated in accordance with the note concerning them in figure 71. The circuit may be traced from terminals Nos. 1 and 2, strip C, to the send jack. The circuit is completed from the jack through the keyboard contacts by means of a cord and plug, one end of which is connected to the teletypewriter base terminals Nos. 32 and 34 according to standard practice with polarities and color code as indicated in figure 71. If full-duplex transmission is not desired, the teletypewriter sendline (dotted lines) is eliminated and wires are connected to terminals Nos. 1 and 2 on terminal strip C. Note that when full-duplex transmission is used, the send circuit of the teletypewriter is entirely isolated from the rest of the table wiring.

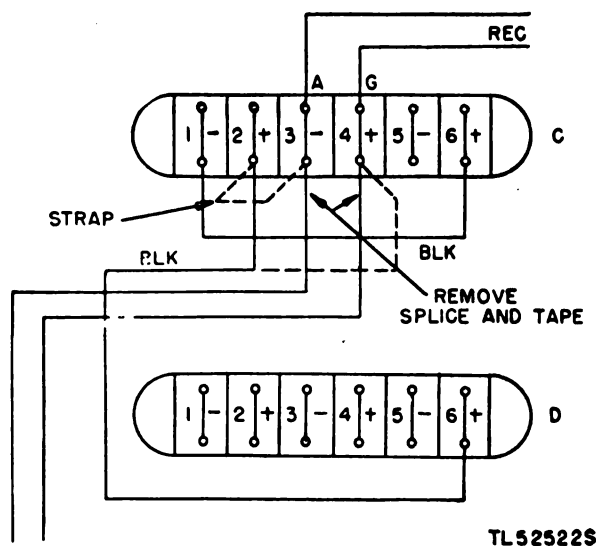

Figure 60. Wiring changes for half-duplex operation.

(3) *Teletypewriter receive circuit (marked REC in figure 71).* The teletypewriter receive line connection is run to the table through an outside duct and is connected to terminals Nos. 3 and 4 of terminal strip C. The table wiring connects these terminals with the jack marked REC (RED). The circuit is completed through the teletypewriter relay

winding by a cord and plug, one end of which is connected to the teletypewriter base terminals Nos. +1 and +2 with polarities and color code as indicated. The teletypewriter receive circuit is isolated from the rest of the table wiring. If full-duplex operation is not used because home copy is desired, it will be necessary to change the wiring at terminal strip C. (See fig. 60.) The teletypewriter receiving leg (REC) is removed from terminals Nos. 3 and 4 and the ends spliced and taped. The wire from the lower screw of terminal No. 2 is removed and connected to terminal No. 4. Terminal No. 2 is strapped to terminal No. 3. These changes simply connect the teletypewriter relay line winding in series with the transmitter contacts and the transmitter distributor contacts, and permits switching them to line one, line two, or test, depending upon the position of the line-switching key lever.

(4) *Test circuit.* The test circuit (fig. 71) consists of a source of 110-volt d-c power (terminals No. 23 and 25 on terminal block B), a 2,000-ohm variable resistor, two test jacks marked BLK and RED, some of the contacts of the line-switching key, the signal line send jack marked BLK, and the transmitter distributor slip connection terminals Nos. 2 and 3. The various elements composing the circuit are connected in series. The teletypewriter relay winding may be placed in the circuit by inserting the red plug into one of the test jacks. The reperforator may also be put into the circuit in a like manner. A strap across terminals Nos. 5 and 6 on terminal strip E will close the test circuit incorporated in the wiring of the table. The 2000-ohm variable resistor located near the test jacks should be adjusted to allow 60 ma of current to flow in the test circuit. The current is measured by connecting a milliammeter in series with terminal 32 at the teletypewriter base (with black plug inserted in the send jack). An external test circuit may be connected to terminal strip E as shown in figure 71, but is used only when other teletypewriter equipment is used at the same station. The external test circuit permits a very flexible local test arrangement to be established whereby any unit, or any combination of units, may be put in the local test circuit.

(5) *Reperforator lines Nos. 1 and 2.* The reperforator lines Nos. 1 and 2 are run into the table through an outside duct and are connected to terminal strip D at terminals Nos. 1 and 2 and terminals Nos. 3 and 4, respectively. These four terminals are wired in the table circuits to a pair of jacks. Line No. 1 is wired to the jack marked BLK and

line No. 2 to the jack marked RED. The circuit is completed to the relay winding in the reperforator by a cord and plug, one of which is connected to the reperforator base terminals Nos. 31 and 32 according to standard practice with the polarity and color code as indicated in figure 71. If operation of the reperforator with line No. 1, line No. 2 or local test is desired, the wiring of the reperforator jacks as compared with the diagram should be checked and all changes made on block D. Figure 61 shows the connection of the red jack. The upper wires on terminal No. 3 are changed to the top lug of terminal No. 5. The lower wire of terminal No. 5 is moved to the lower leg of terminal No. 4. To connect the black jack, the top wires of terminal No. 1 are moved to the upper screw of terminal No. 5 and the lower wire of terminal No. 5 is changed to the bottom screw of terminal No. 2. With either of these connections the reperforator will be controlled by the line-switching key.

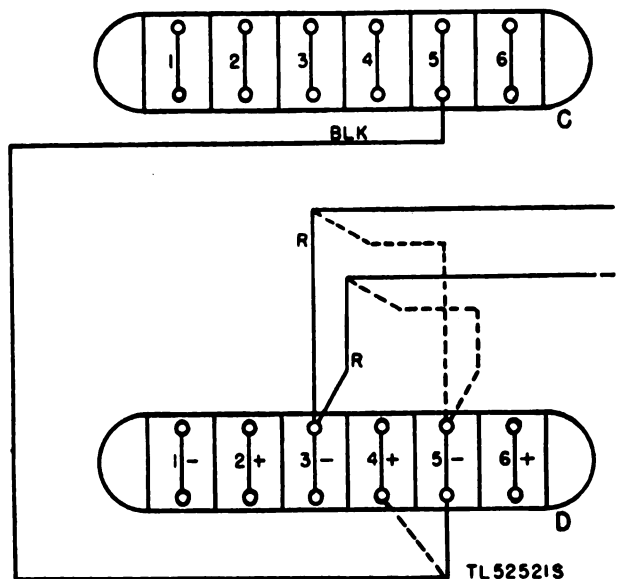

Figure 61. Wiring changes for reperforator.

(6) *Resistance.* The flat type resistors in the machine may be connected in the transmitting circuit in the same way as on the M-15 set. Remember that this resistance (if used) will cut into one circuit and out of another when the position of the switching-key lever is changed unless full-duplex operation is used. This would cause fluctuations of the line current, which might possibly affect the operation of other machines.

29. Tables XRT-115 and XRT-116

a. Table XRT-115 is one of the newer type tables and is similar to tables XRT-97 and X 106. It

has all the connections, etc., mounted in a metal container beneath the table. Provisions have been made to furnish either line current or a local test circuit. For complete details about table XRT-115, refer to TM 11-2215.

b. Table XRT-116 is similar to tables XRT-96 and XRT-107, but has facilities for furnishing line current to two lines and also for a test circuit. For complete details about table XRT-116, refer to TM 11-2216.

30. Power Sources

a. GENERAL. Teletypewriters, transmitter distributors, reperforators, and perforators all require electrical power for their operation. In general, d-c power is adequate for all purposes although a combination of an a-c and d-c power is used frequently. D-c power may be supplied from commercial sources, storage batteries, or, if an a-c power source is available from motor-generator sets, or rectifiers. A-c power is used frequently for the operation of the teletype equipment motor and, in some cases, for the universal magnet of the transmitter distributor.

b. STORAGE BATTERIES. Because of weight, size, and maintenance difficulties and the fact that a second source of power is required for their charging, storage batteries find little application as the source of power for teletypewriter operation.

c. MOTOR GENERATORS. At large terminal stations where many lines converge and where several units of teletypewriter equipment may be installed, the d-c power load may be enough to warrant the installation of a motor generator set. The d-c output of the generators of these sets usually is fed through a filter before it is applied to the teletypewriter equipment. Most installations at military establishments are of such size as to make the use of rectifiers, operating from available a-c power mains, more suitable than a motor-generator set.

31. Fixed Station Rectifiers

a. GENERAL. In most military fixed station installations rectifiers REC-10 and REC-13 are used as sources of direct current. Each is designed to operate from an a-c source of approximately 110 volts. They are shown in figures 62 and 63. Both input and output power cords have polarized plugs which permit their insertion only into the correct receptacle.

b. RECTIFIER REC-10. This rectifier is designed to deliver 0.200 ampere at 120 volts direct current from a 105- to 125-volt, 50- to 60-cycle, a-c single-phase power supply. It consists of an insulated-type input transformer with variable secondary taps, a full-wave selenium rectifying element, a power factor correction capacitor, and a bleeder resistor. All

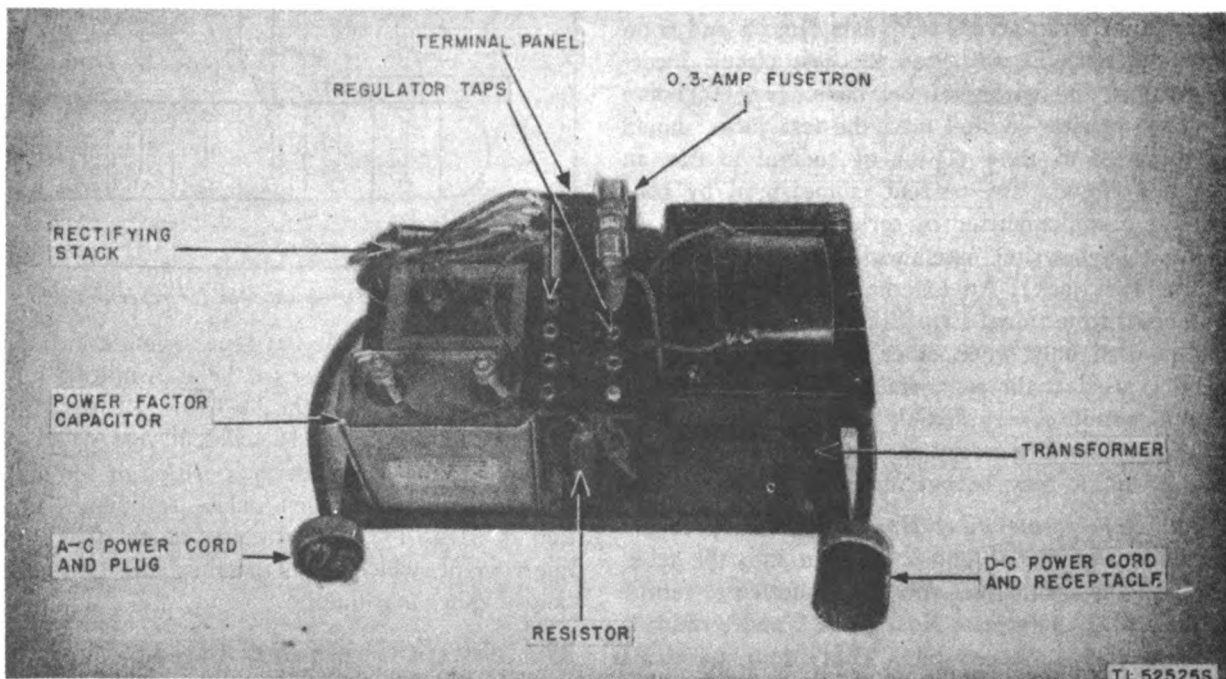

Figure 62. Rectifier REC-10.

parts are secured to a metal base which has rubber feet for shelf mounting. The rectifier is furnished complete with cover, cords, and plugs for making a-c and d-c connections. The ventilated cover which fastens to the base by means of screws has a black wrinkle finish. Three coarse and five fine secondary transformer taps are provided, marked L, M, and H and 1, 2, 3, 4, and 5 for adjusting the d-c output for any particular line requirement and to correct for aging of the rectifier element. When new, the flexible leads are set on taps M and either 1, 2, or 3 to deliver 0.200 ampere of 120 volts direct current. If at any time it is necessary to use a maximum regulating tap to obtain proper output current, the rectifier should be withdrawn from service and repaired.

c. RECTIFIER REC-13. Figure 63 shows rectifier REC-13. This rectifier is designed to deliver continuously, 0.600 ampere at 120 volts direct current from a 105- to 125-volt, 60-cycle, a-c, single-phase power supply. It consists essentially of the same components as the REC-10 and normally is used with the Model 19 composite set. It is mounted on a shelf at the rear of the table. This rectifier is provided with a door in the front of the cover to permit access to the two regulating panels within the cover. The left-hand panel has terminals for the

transformer primary taps which are marked for input voltages of 10, 115, and 125 volts. A 6-ampere fuse for protecting the transformer is also mounted on this panel. A flexible lead is used for connecting alternating current to the proper primary tap. The selection of the primary tap will depend on the voltage of the a-c power supply. In no case should the connection to these taps be changed for the purpose of regulating d-c output voltage. To regulate the d-c output and to compensate for aging of the rectifier element, three coarse regulator taps marked L, M, and H and five fine regulator taps marked 1, 2, 3, 4, and 5 terminate on the right-hand panel. When the rectifier is new, the regulator taps are set on L and either 1, 2, or 3 to give the minimum of 120 volts direct current at 0.600 ampere. Each fine tap will change the d-c output voltage approximately 2 volts and each coarse tap will change the output voltage approximately 8 volts when the direct current is 0.500 ampere. A 1.25-ampere fusetron is located on the right-hand panel for overload protection in the output circuit. If at any time it is necessary to use the maximum regulating tap to obtain the proper output current, the rectifier should be withdrawn from service and repaired.

d. RECTIFIERS REC-20 AND REC-30. Rectifiers REC-29 and REC-30 are used with tables XRT-

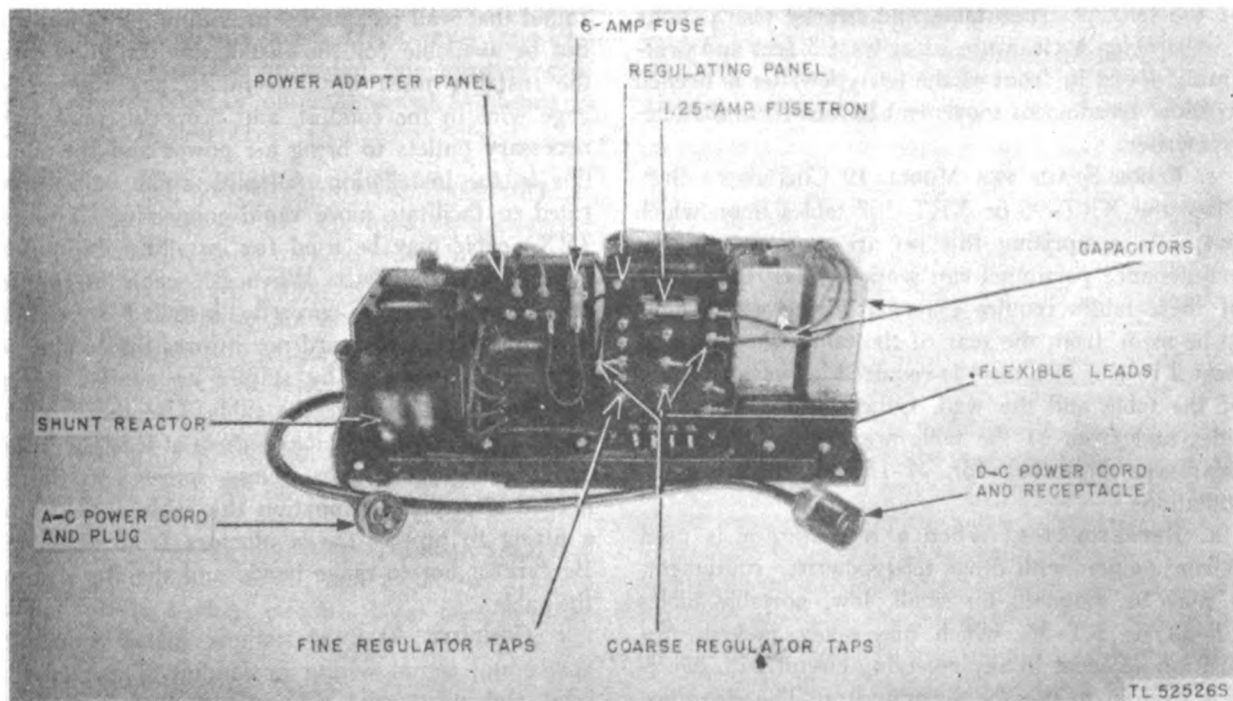

Figure 63. Rectifier REC-13.

115 and XRT-116, respectively, and differ little in their construction and in functions they perform from rectifiers REC-10 and REC-13. TM 11-2215 contains detailed information on rectifier REC-29 and TM 11-2216 contains detailed information on rectifier REC-30.

32. Space Requirements

a. GENERAL. Teletypewriter equipment is compact and requires little space for actual installation, but it is necessary to provide operating and maintenance personnel with enough space to permit smooth operation and allow necessary maintenance work to be done. The following floor space requirements apply to fixed station installations and have no bearing on field installations. Requirements in the field are dictated by existing conditions.

b. FLOOR SPACE PER MODEL 15 TELETYPEWRITER. When an M-15 teletypewriter is to be operated in a permanent or semipermanent location, place the unit at least 10 inches from the rear wall. This distance will allow the top cover of the teletypewriter to be swung backward for reloading the paper roll. Since all external connections are made at the front of the XRT-97 and XRT-106 tables, it is unlikely that an occasion will arise requiring either operating or maintenance personnel to work behind the installation. A clearance of 2 feet between either side of the teletypewriter table and nearby obstructions is desirable. A clearance of at least 3 feet and preferably 4 feet in front of the teletypewriter is needed to allow freedom of movement to and from the teletypewriter.

c. FLOOR SPACE PER MODEL 19 COMPOSITE SET. Place the XRT-96 or XRT-107 tables upon which the units comprising this set are mounted so that maintenance personnel can work behind them. Both of these tables require external wiring connections to be made from the rear of the table; therefore, at least 2 feet of clearance is required between the rear of the table and the wall. Other clearances at the sides and front of the table are comparable to the clearances indicated for M-15 teletypewriter installations.

d. REPERFORATOR. When a reperforator is used in conjunction with other teletypewriter equipment, it may be mounted on small, low, portable tables RT-33 or RT-34, which are easily moved into position adjacent to any receiving circuit with which it is desired to use the reperforator. The clearance previously indicated for other teletypewriter equipment provides adequate space to allow the reper-

forator to be so placed. If it is desirable to install a reperforator and an associated transmitter distributor permanently, table XRT-98 may be used. Clearances for this installation are comparable to those indicated for M-15 teletypewriter installations.

33. Lighting

a. GENERAL. Installations of teletypewriter equipment must be adequately provided with proper lighting, both day and night. Persons in charge of an installation must bear in mind that mental fatigue and eye strain are great enough under best possible working conditions, so that the proper placement of equipment is absolutely essential. Window light from the rear of the operator's position is desirable.

b. POSITION OF ARTIFICIAL LIGHTING. For nighttime lighting use light bulbs placed so that the light falls directly on the platen and the keyboard, in such a way that the image of the light and reflector does not stand on the glass cover of the set. A portable drop lamp and extension cord are convenient assets to the operating personnel and are almost a necessity to maintenance personnel.

34. External Wiring

After placing teletypewriter equipment in the location decided upon, consider the means of electrically connecting the various component parts of the system. In some fixed installations, it will be found that wall receptacles providing a-c power may not be available for the installation. In such cases, the installer must install conduit, run the proper gage wire in the conduit, and properly connect the necessary outlets to bring a-c power and the signal line to the installation. All outlets can be incorporated to facilitate more rapid connection. Armored (BX) cable may be used for installing the outlets.

a. ARMORED CABLE. When BX cable is run for outlets, it must be correctly installed so that it neither presents a hazard nor injures the conductors within it. Secure it by staples or similar fittings which will not damage the cable. Use these staples every 4½ feet or less; locate them at least 12 inches from each outlet box unless some flexibility is needed. At each termination the cable should have a fitting to protect the conductors from abrasions. Be careful not to make bends and thereby damage the cable.

b. CONDUIT. At fixed stations, install connection power and signal wiring in conduit. This makes a solid and substantial set-up, with little trouble to disrupt future communications. Inclose signal lines in the same conduit as power lines or in separate

conduit from power lines and terminate them in a jack box in a polarized outlet. Outlets will facilitate rapid connection of teletypewriter equipment to power and signal lines.

c. **GAGE OF WIRE.** The wire used to carry a-c power from the building wiring to the outlets at the installation must be capable of carrying the combined current of all equipment to be connected. When the installation comprises a single M-15 teletypewriter, No. 14 AWG (American Wire Gage) wire may be used for power connections. As the number of the gage increases, the diameter of the wire decreases. For example: No. 14 AWG is 0.064 inch in diameter, and No. 18 is 0.040 inch in diameter. In an installation of two M-19 composite sets, a reperforator and an M-15 teletypewriter, No. 8 or No. 10 AWG wire is best. All wire should be rubber and cotton braid insulated. Signal lines may be of No. 18 AWG wire, but require the same insulation as do power lines.

d. **TEST OF POWER SOURCE.** Before starting to arrange external wiring, determine if one side of the a-c power is grounded. This may be done with an a-c voltmeter or a 100-volt light bulb in series with two test leads. By connecting the indicating device from one lead of the alternating current to ground, then the other lead of the alternating current to ground, it can be determined whether either of the a-c leads is grounded. If neither side of the a-c power is grounded, either lead may be connected to any terminal of the outlet. If, however, one lead is grounded, then the grounded side must be connected to the table or outlet terminal as shown in figures 69, 70, and 71.

35. Noise Elimination in Radio Receivers

When radio receivers are operated near teletypewriter equipment, noise may be picked up from the teletypewriter and its power supply leads. Proper shielding of the radio antenna lead-in wires, and the use of proper care in the location of the lead-in wires with respect to teletypewriter installations, such as wider separation and elimination of parallel paths, will aid considerably in cutting down interference. Reversing the power leads to the teletypewriter equipment may also help to reduce the noise. For safety as well as interference reduction, ground securely all tables, conduit, and metal parts not a portion of the various circuits. Most teletypewriter equipment makes use of filters to prevent radio interference even at very high frequencies. These filters are used even though radio noises are not a problem; they reduce the wear on contact points.

36. Safety Devices

Safety devices are designed to protect operating and maintenance personnel and to protect equipment at a plant. Physical barriers, discipline, and circuit insulation and protective grounds help in accomplishing protection of personnel. Plant and equipment protective units and the manner in which they are used vary somewhat with particular situations, but in general the line protective devices are of three different types. These are open-space cut-out, heat coils, and fuses. Fustats and fuses are used for internal protection of the various teletypewriter units. Receivers for the fustats and fuses are built into the tables or within the units themselves. Nullification of any of the fuses or protective devices by straps, coins, tinfoil, or any other substance should not be permitted, except whenever the value of possible operation of the equipment is more important than the possible sacrifice of the equipment. When such instances occur, install new fuses or protective devices as soon as possible.

a. **PROTECTION OF PERSONNEL.** (1) *General.* Voltages used in teletypewriter installations are as dangerous as those of house wiring. Some installations use 200 volts alternating current. *This can be very dangerous.* Voltages associated with the rectifiers may reach hazardous values, especially if the output and bleeder circuits are open.

(2) *Covers, panels, and boxes.* Keep the covers, panels, and boxes in place and closed on all equipment on which they are provided. Replace rectifier covers and panels, and covers on the backs of the tables when the cause for which they were removed no longer exists. Do not put equipment into service unless its covers and guards are in place.

(3) *Motor generators.* Motor generators or any rotating equipment which may be installed in a teletypewriter station must have its rotating parts covered so that it is impossible for attending personnel to become entangled in the moving parts.

(4) *Grounds.* All teletypewriter equipment is provided with ground connections that are interconnected by ground wires incorporated with the power supply or connecting cords. The red wire in the motor and rectifier cords are the ground wires; the white wire is a ground shield. For personnel protection and elimination of radio interference it is essential that these wires be connected to the ground connections of the various parts. Grounds on public water systems are preferred to any other type, and the connection to this type of ground must be in a good condition. Ground

all conduit, metal tables, and other exposed metal in the station.

b. PROTECTION OF PLANT AND EQUIPMENT. (1)

General. Ordinarily, all power circuits associated with teletypewriter equipment have some form of current-limiting device incorporated in the circuit such as a fuse or current-limiting resistor. Additional protective devices must be used in nearly all installations to protect the station equipment from excessive currents or voltages induced in the line from foreign sources. These sources include lightning and other atmospheric disturbances, electric power lines running near the signaling wires, and high-powered radio transmitting apparatus. Practically all outside plant wire may be exposed from time to time to one or more of these foreign hazards. Accordingly, whenever exposed wires are led into a teletypewriter station they should be connected through certain protective apparatus. This protective apparatus must be designed so that it will be sufficiently sensitive to operate before the plant which it is protecting is damaged, and, on the other hand, not so sensitive as to cause an unnecessary number of service interruptions.

(2) *Open-space cut-outs.* The most common type of open-space cut-out (fig. 64) consists of two carbon blocks having a separation of a few thousandths of an inch, one of which is connected to ground, and the other to the wire to be protected. One of the carbon blocks is much smaller than the second (A of fig. 64) and is mounted in the center of a porcelain block. When the voltage on the wire becomes too high, the wire is grounded by arcing across the small air gap between the carbon blocks. If a considerable current flows across the gaps in this way, enough carbon may be pulled from the block by the arc to partially fill in the gap and cause permanent grounding. Or, in extreme cases, when the discharge is prolonged and sufficiently high, the glass cement with which the small carbon insert is held in a porcelain block may be melted, with the result that the blocks are forced into direct contact by mounting springs in which they are held. (See B of fig. 64.) However, in the majority of protector operations, blocks do not become permanently grounded. Open-space cut-outs are used only

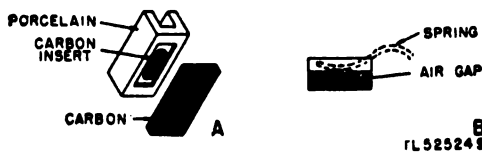

Figure 64. Open-space cut-out.

in conjunction with the signal line to prevent it from conducting large foreign voltages into the equipment.

(3) *Line fuses.* When a signaling line is grounded by the operation of an open-space cut-out, current will continue to flow through the signaling conductor to ground so long as the exposure continues. This current may be large enough to damage the signaling line or the protective apparatus itself. Accordingly, it is necessary to insert in the conductor, on the line side of the open-space cut-out, a device which will open the conductor when the current is too great. Fuses are used for this purpose. Figure 65 shows a station protector using line fuses and open-spaces cut-outs. These fuses should not be confused with the fustat and fuse protection used on teletypewriter equipment for internal protection which are entirely different in design and function.

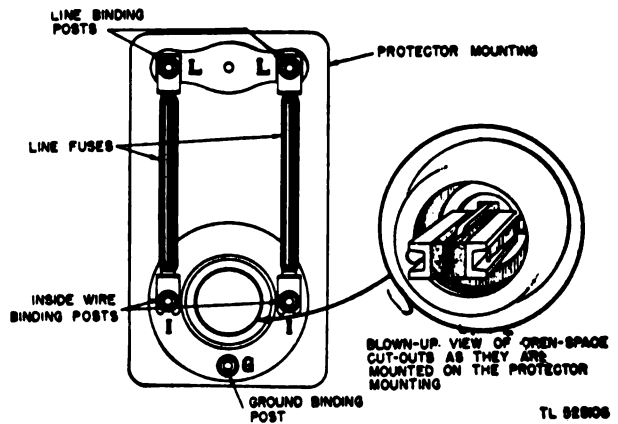

Figure 65. Station protector.

(4) *Heat coils.* Sometimes it is necessary to protect teletypewriter equipment against external effects in which the voltage is not high enough to operate the open-space cut-out, nor the current high enough to operate fuses, but still high enough to cause damage if allowed to flow over a long period. These currents are usually called sneak currents and are guarded against by the use of heat coils. (See fig. 66.) A heat coil consists of a small coil of wire wound around a copper tube which is connected in series with the wire to be protected. Within the copper tube and held in place by easily melted solder, is a metal pin which is connected to the line side of the coil. If sufficient current flows through the coil to melt the solder, this pin will move under pressure of its mounting spring and thus connect the line to ground. In some cases, heat coils of a similar nature are used to open circuits, as in the case of conductors entering a station. The heat coil

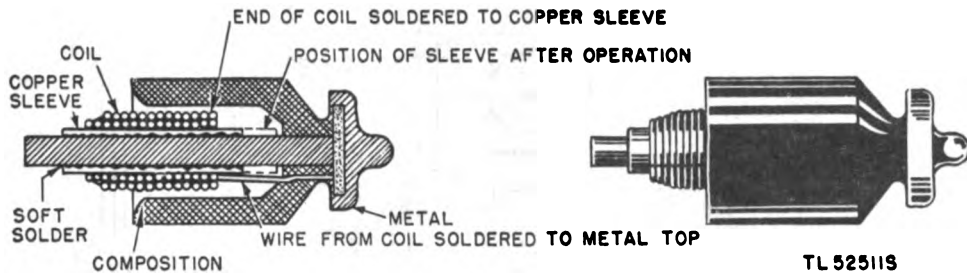

Figure 66. WECO type heat coil.

is mounted on the station side of the open-space cut-out. In this position, the heat coil wiring helps the operation of the space cut-out by presenting a considerable resistance to suddenly applied voltages such as those produced by lightning discharges.

(5) *Terminal protectors.* Heat coils and open-space cut-outs are mounted in protector mountings as shown in figure 67. This protector is ordinarily referred to as high potential sneak current protector. The outside line connections terminate on the inner springs (A and B) and the wires from the teletypewriter terminate on the outer springs (C and D).

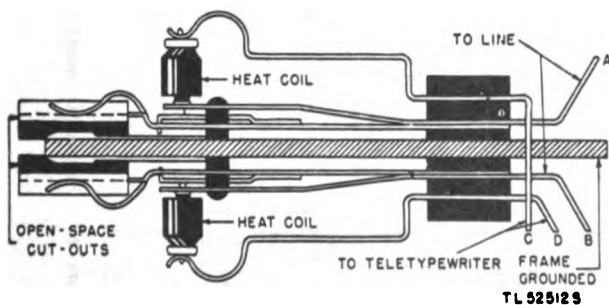

Figure 67. WECO central office protector.

(6) *Power fuses.* Figure 68 is a table of recommended fustat protection. The type of motor drive affects the rating of the fuse required. It is recommended that the supply mains, whether alternating current, direct current, or both, be protected at the main power switch with plug or cartridge-type fuses or a protective circuit breaker. The power supply mains are not fused as they enter the table terminal strip but at each separate unit or unit combination. There are three types of protection used within the equipment: Fuse, fusetron, and fustat. A fuse, cartridge, or plug, is designed to open the circuit immediately when the current rises above its capacity. A fusetron is designed to open the circuit when the current rises above its capacity but is capable of withstanding sudden or momentary surges above its maximum capacity without blowing. A fustat operation is identical to that of the fusetron but the fustat has a different base and when used with a fuse receptacle must be provided with an adapter. The fustat adapter will not permit insertion of a wrong capacity fustat. All three types have the capacity stamped on them and usually are of such material that visual testing is possible.

EQUIPMENT	LOCATION	MOTOR DRIVE			
		110V. A.C. 9Y.N.	110V. A.C. 60V. 80-80%	110V. A.C. 60V. 25~	110V. D.C. 60V.
TELETYPEWRITER	ON TELETYPEWRITER BASE	3.2-AMP	1.60-AMP	1.40-AMP	0.6-AMP
TRANS. DIST.	G ON XRT-96 OR 107	3.2-AMP	1.25-AMP	1.25-AMP	0.6-AMP
REPERF.	H ON XRT-96 OR 107	3.2-AMP	1.60-AMP	1.25-AMP	0.6-AMP
EQUIPMENT	LOCATION	SIZE FUSETRON	PURPOSE		
REC-10	REGULATOR PANEL	0.3-AMP	OUTPUT OVERLOAD		
REC-13	REGULATOR PANEL	6-AMP	TRANSFORMER PROTECTION		
	POWER ADAPT. PANEL	1.25-AMP	OUTPUT OVERLOAD		

TL 52513S

Figure 68. Table of recommended fusetron protection.

TABLE CONNECTIONS FOR VARIOUS POWER SUPPLIES		POWER CONNECTIONS
A	DC FOR LOCAL CIRCUITS TO LINE RELAY AND SELECTOR MAGNETS	AS SHOWN
1	110V AC 50-60 CYCLES RECT CONTROL BY PTR MTR SWITCH	REMOVE WIRE FROM TERM. 3 ON RECEPTACLE "B" AND CONNECT TO TERM. 1
2	110V AC 50-60 CYCLES RECTIFIER "ON" CONTINUOUSLY FOR UPPER CASE "H" OR "M" MOTOR CONTROL	CONNECT AC TO RECEPTACLE "B" AS SHOWN. REMOVE WIRES FROM + AND - TERMINALS ON RECEPTACLE "C" AND TAPE ENDS. CONNECT + AND - 110V DC TO CORRESPONDING TERMS. OF RECEPTACLE "C".
3	110V AC 50-60 CYCLES RECTIFIER CONTROL BY PTR MTR SWITCH	SAME AS ARRGT 1 ABOVE EXCEPT ADD 99971 RESISTOR AS SPECIFIED IN NOTE "A" BELOW
4	110V AC 25 CYCLES RECTIFIER "ON" CONTINUOUSLY FOR UPPER CASE "H" OR "M" MOTOR CONTROL	SAME AS ARRGT 2 ABOVE EXCEPT ADD 99971 RESISTOR AS SPECIFIED IN NOTE "A" BELOW
5	110V DC POWER SUPPLY EXTERNAL TO TABLE (EITHER + OR - GROUND)	95050 CORD NOT USED. STRAP PTR TERMS 22 AND 25. STRAP PTR TERMS 23 AND 24
6	110V DC POWER SUPPLY EXTERNAL TO TABLE (+ GROUNDED)	95050 CORD NOT USED. STRAP PTR TERMS 22 AND 24. STRAP PTR TERMS 23 AND 25

COLOR CODE
BK BLACK
Y YELLOW
R RED
G GREEN
W WHITE

- POWER LEADS
- TABLE WIRING - RM 31551 - #18 DELTABESTON
- CC WIRE - BLACK
- DEMOTES SHIELDED CABLE
- DEMOTES RECEPTACLES AND PLUGS SHOWN FROM SLOT AND PRONG FACES
- DEMOTES WIRES IN BX

NOTE:
 A. REMOVE LEADS FROM TERMINAL NO. 2 OF RECEPTACLE "B" AND CONNECT A LEAD FROM 99971 RESISTOR TO TERMINAL NO. 2 OF RECEPTACLE "B". SPLICE AND TAPE WIRES REMOVED FROM TERMINAL TO OTHER RESISTOR LEAD.

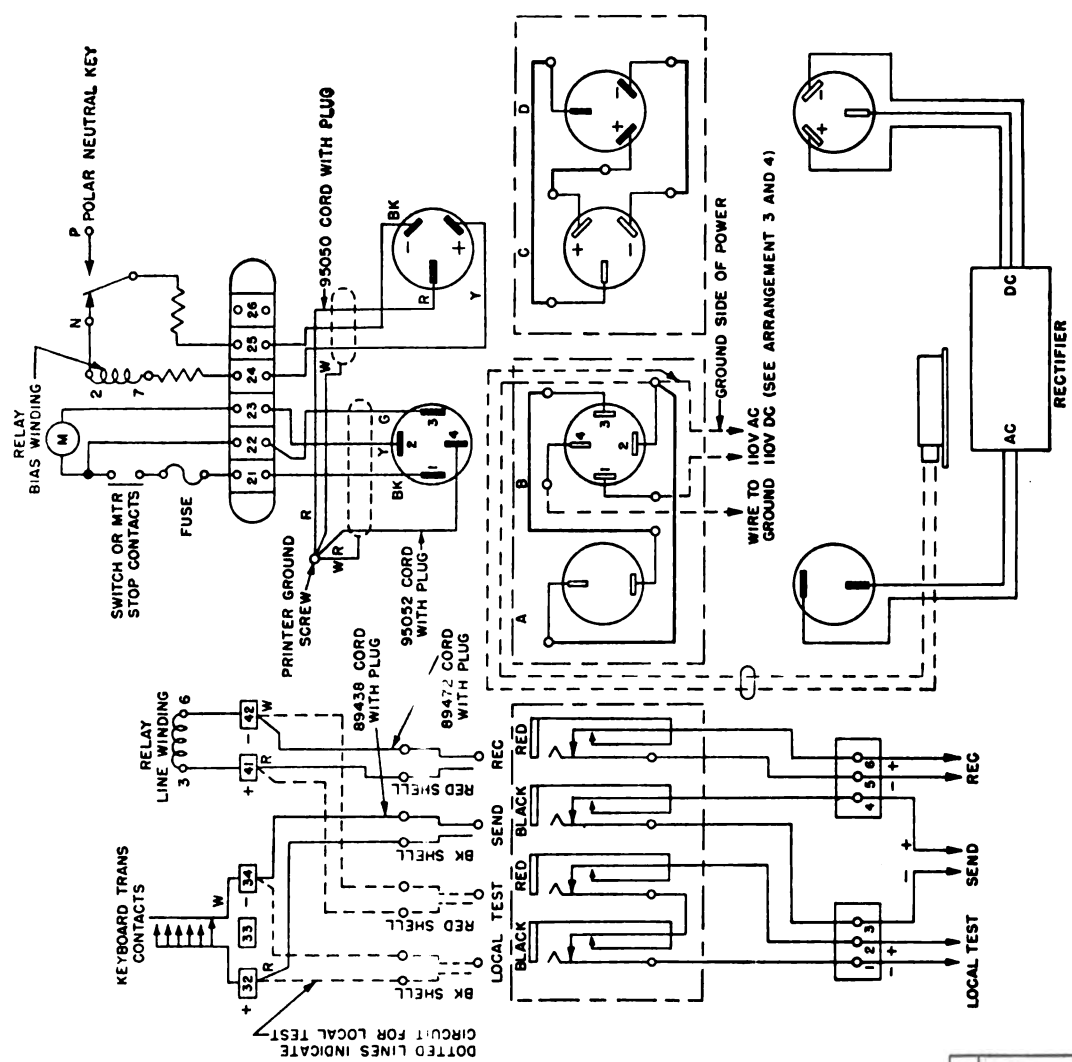

Figure 69. Schematic wiring diagram of table XRT-97.

TABLE CONNECTIONS FOR VARIOUS POWER SUPPLIES		POWER CONNECTIONS
1	DC FOR LOCAL CIRCUITS TO LINE RELAY AND SELECTOR MAGNETS	AS SHOWN
2	110V AC 50-60 CYCLES RECT CONTROL BY PTR MTR SWITCH	REMOVE WIRE FROM TERMINAL 3 ON RECEPTACLE "B" AND CONNECT TO TERMINAL 1
3	110V AC 50-60 CYCLES RECTIFIER "ON" CONTINUOUSLY FOR UPPER CASE "H" OR "M" MOTOR CONTROL	CONNECT AC TO RECEPTACLE "B" AND REMOVE WIRE FROM TERMINALS 3 AND 4. CONNECT "C" AND TAPE ENDS TO CORRESPONDING TERMINALS OF RECEPTACLE "C"
4	110V AC 25 CYCLES RECTIFIER CONTROL BY PTR MTR SWITCH	SAME AS ARRGT 1 ABOVE EXCEPT ADD 99971 RESISTOR AS SPECIFIED IN NOTE "A" BELOW
5	110V AC 25 CYCLES RECTIFIER "ON" CONTINUOUSLY FOR UPPER CASE "H" OR "M" MOTOR CONTROL	SAME AS ARRGT 2 ABOVE EXCEPT ADD 99971 RESISTOR AS SPECIFIED IN NOTE "A" BELOW
6	110V AC 25 CYCLES 110V DC POWER SUPPLY EXTERNAL TO TABLE (EITHER + OR - GROUNDED)	SAME AS ARRGT 3 ABOVE EXCEPT ADD 99971 RESISTOR AS SPECIFIED IN NOTE "A" BELOW
7	110V DC POWER SUPPLY EXTERNAL TO TABLE (+ GROUNDED)	95050 CORD NOT USED. STRAP PTR TERMS 22 AND 25. STRAP PTR TERMS 23 AND 24
8	110V DC POWER SUPPLY EXTERNAL TO TABLE (- GROUNDED)	95050 CORD NOT USED. STRAP PTR TERMS 22 AND 24. STRAP PTR TERMS 23 AND 25

POWER LEADS
 TABLE WIRING - RM 31551 - #18 DELTARESTON
 CC WIRE - BLACK
 Y WIRE - YELLOW
 R WIRE - RED
 G WIRE - GREEN
 W WIRE - WHITE

DEMOTES SHIELDED CABLE
 RECEPTACLES AND PLUGS SHOWN FROM SLOT AND PRONG FACES
 DENOTES WIRES IN BX

NOTE:
 A. REMOVE AND DISCARD THE STRAP CONNECTED BETWEEN THE UPPER A. TERMINAL OF RECEPTACLE "A" AND TERMINAL #2 OF RECEPTACLE "B". REMOVE GROUND LEAD FROM THE LATTER TERMINAL. CONNECT A LEAD FROM 99971 RESISTOR TO TERMINAL #2 OF RECEPTACLE "B", AND CONNECT OTHER RESISTOR LEAD AND GROUND LEAD TO UPPER TERMINAL OF RECEPTACLE "A".

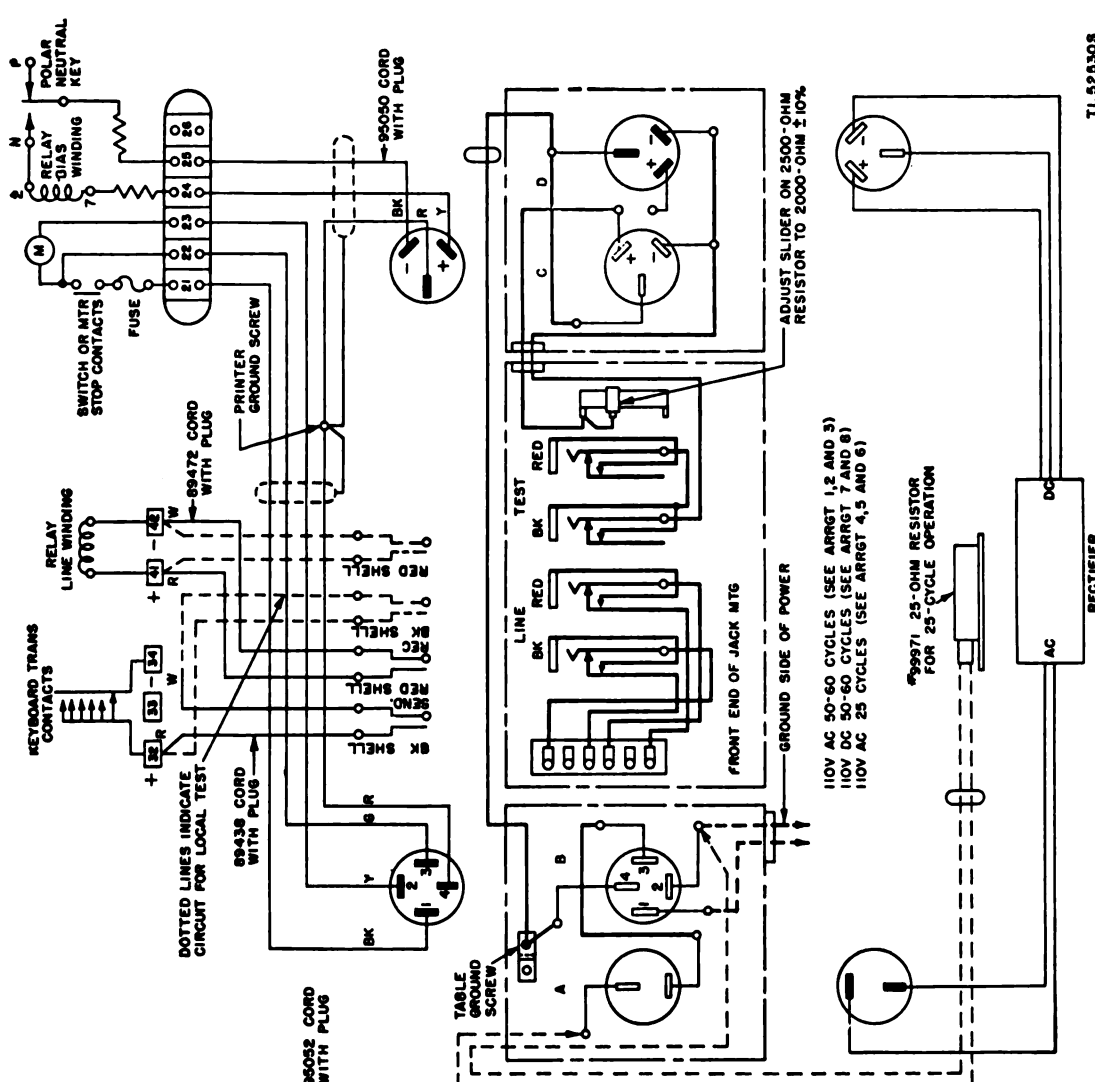

TL528308

Figure 70. Schematic wiring diagram of table XRT-106.

Section II. FIELD TELETYPEWRITER EQUIPMENT

37. Introduction

Use of teletypewriter equipment by combat units requires that each installation be capable of being readily made, removed, transported, and reinstalled. Installation of Army field teletypewriter equipment is not difficult and can be learned in a comparatively short time. However, to install, line up, and maintain this equipment properly, the teletypewriter mechanic must know the adjustments, circuits, and theory of operation. Switchboard BD-100 and its associated equipment will be covered in the following paragraphs. Teletypewriter Sets EE-97-(*), EE-98-(*), and EE-102, and Reperforator Teletypewriter Sets TC-16 and TC-17 provide complete portable sending and receiving teletypewriter stations for field use. Many of their component parts are interchangeable. Field teletypewriter equipment, since it must be portable, is housed in cases and chests when it is not in use. These chests are used at installations as tables, etc., for the equipment. All sets are complete and designed for a definite use. Some sets are designed for locations where a commercial or a military source of power is available;

others include their own power unit. Some are designed for use in a central office, others for use as substations only.

Note. Official Signal Corps nomenclature followed by (*) is used throughout this manual to indicate any item of equipment regardless of its model or procurement.

38. Teletypewriter Set EE-97-(*)

Teletypewriter Set EE-97 or EE-97-A provides equipment for a complete sending and receiving teletypewriter station, including provision for local and distant line current supply. These sets are intended for location where no commercial power is available or where it may not be available at all times. Figure 72 shows the component parts of Teletypewriter Set EE-97 removed from their chests. The difference between Teletypewriter Set EE-97 and Teletypewriter Set EE-97-A is in the type of printing unit used. Teletypewriter Set EE-97 has Printer TG-7-A as a component, and Teletypewriter Set EE-97-A has Teletypewriter TG-7-B as a component. Two Ground Rods MX-148/G are carried separately. Supplies and accessories include rolls of teletypewriter paper, inked ribbons, fuses, power extension cords, and a three-way power plug. All are packed in Chest CH-53 or CH-53-A with Line Unit BE-77-(*). (See fig. 72.)

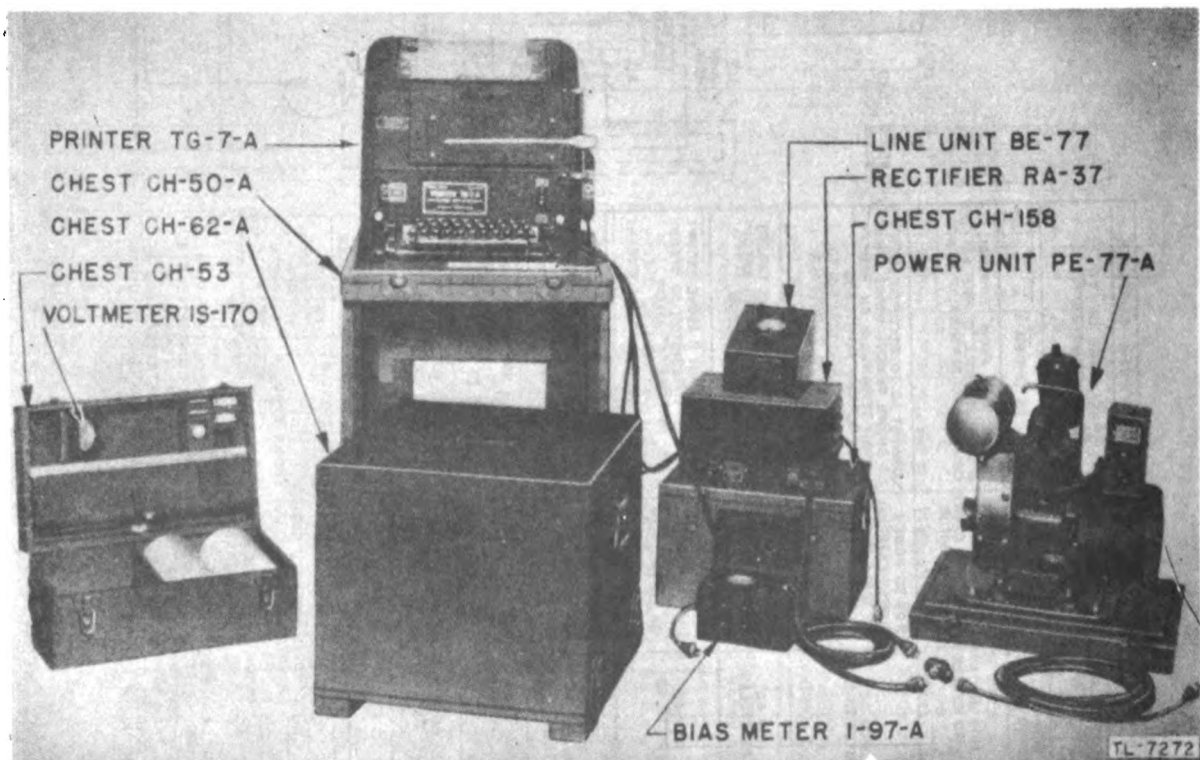

Figure 72. Teletypewriter Set EE-97-(*).

39. Printer TG-7-A

Printer TG-7-A is a typebar page printing unit (Teletype Corporation model 15) which has been slightly modified to adapt it for Army field use. (See figs. 73 and 74.) The printing unit is arranged to be packed for transportation in Chests CH-50-A and CH-62-A. Lord mountings are used for fastening the unit in the chest to minimize shock to the equipment during transportation. In operation, Chest CH-50-A is used as a teletypewriter table,

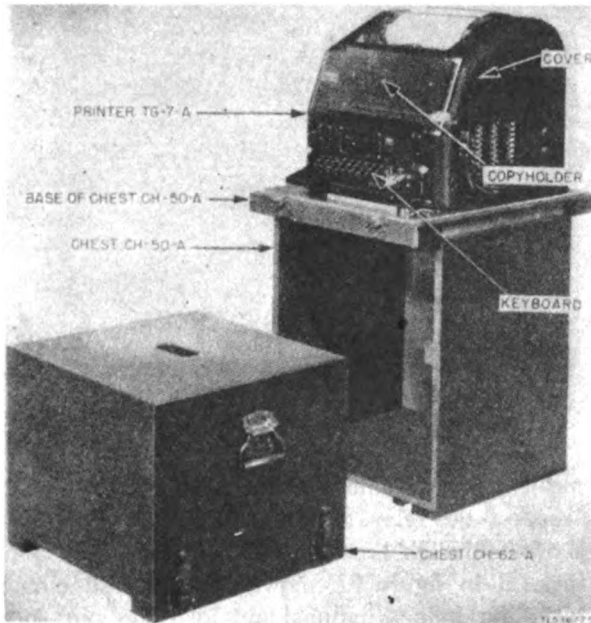

Figure 73. Printer TG-7-A and chests.

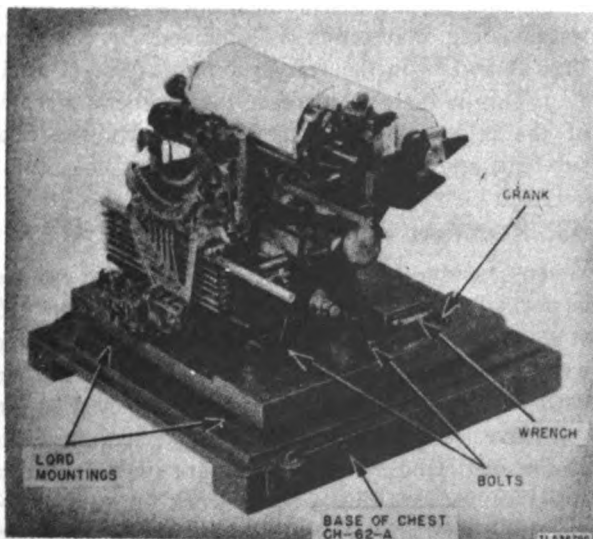

Figure 74. Base of Chest CH-62-A with typing unit.

and Chest CH-62-A is used as a seat for the operator. The teletypewriter motor circuit requires a 115-volt, 150-watt source of power and may be arranged for operation on 50-60-cycle alternating current or direct current and 25-cycle direct current. The transmitting contacts are connected to the line with a black shell plug, and the selector-magnet coils of the typing unit are connected to the line with a red shell plug. The printing unit is arranged to use an external line relay but contains a mounting block for a 215- or 255-type relay which may be used internally with a slight modification of the teletypewriter wiring.

40. Teletypewriter TG-7-B

Teletypewriter TG-7-B is essentially the same as Printer TG-7-A. All parts and assemblies of the two machines are interchangeable. However, certain parts of Printer TG-7-A have been omitted; namely, one terminal block (30 and 40 blocks have been combined); relay mounting block and associated circuits; polar neutral key; and motor-control relay. The typing unit is packed in Chest CH-62-B or CH-62-F, and the base, keyboard, and cover are packed in Chest CH-50-B or Chest CH-50-F. Teletypewriter TG-7-B is arranged so that the motor can be operated on 115-volt, 40-cycle alternating current, as well as any power sources listed for Printer TG-7-A. The parts used with the WECO polar relay are not provided; otherwise, the signaling circuit is the same as the one in Printer TG-7-A.

41. Line Unit BE-77-A

a. GENERAL. The line unit is an electrical device especially designed for use as part of Army tactical (field) teletypewriter sets which transmit and receive d-c neutral-type line signals. The line unit provides the means for connecting the teletypewriter station to the signal line. Its principal function is to receive signal impulses from the line and repeat them, undistorted, to the selector magnet coils of the teletypewriter. By proper adjustment of the line unit relay, much of the distortion introduced into the signals by the signal line may be removed from the signals. The line unit also provides a means for measuring and adjusting the line current and, when necessary, for connecting a local source of current into the line circuit. The line unit normally requires 115 volts of direct current, although stable voltages between 105 and 125 volts will generally give satisfactory operation.

d. COMPONENTS. Most of the components of the line unit, including the single-current type 41-C relay, are mounted within a sheet-steel housing. Binding posts and jacks for teletypewriter connections, line fuse and blown-fuse indicator, line rheostat, meter, and meter key are mounted on the top cover of the line unit. (See fig. 75.) A door in the front of the housing permits access to the line relay and switch panel. The bias circuit adjustment and relay and line current switches are mounted on the switch panel. (See fig. 76.) A power cord for connection to a source of direct current is located at the rear of the line unit. Condensed operating instructions are provided on the right-hand side of the line unit, and a schematic diagram is provided on the left-hand side

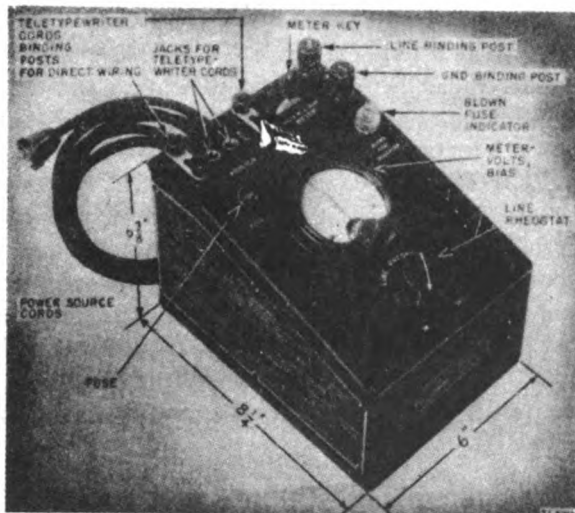

Figure 75. Line Unit BE-77-A.

42. Neutral Relays

Neutral relays used in Line Unit BE-77-A are called single-current relays. (See fig. 77.) The operation of this relay is extremely simple. When no current flows through the windings, the armature spring pulls the armature away from the magnet core, and the armature contact closes with the spacing contact (bottom). When enough current flows through the relay windings in either direction, the core becomes magnetized and attracts the armature, causing the armature contact to close with the marking contact (top). The spring which pulls the armature back when there is no current flowing in the relay winding is called the biasing spring. The tension on the biasing spring is adjustable by

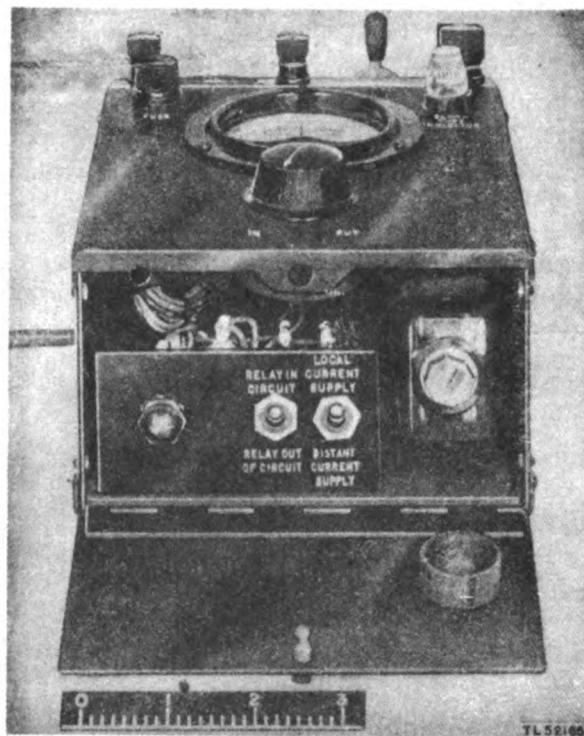

Figure 76. Line Unit BE-77-A, door open.

means of the thumbscrew or adjusting knob on the front of the relay. For simplicity, only one coil is shown although there are actually two equal windings. B in figure 77 shows the electrical circuits, including both windings and also the pin socket arrangement facing the socket end of the relay. Note that each relay winding has a resistance of 100 ohms, and that the windings are so poled that a series-aiding connection is obtained by strapping lugs D and U in the relay sub base. (See C of fig. 77.) This is done to increase the magnetic strength of the relay. D of figure 77 illustrates the relay sub-base and pin terminal arrangement.

43. Rectifiers RA-87, RA-37, and RA-89

When a source of a-c power is available, a rectifier is normally used to convert the a-c power to 115-volt direct current for operation of the teletypewriter signal circuits and line unit. The rectifiers used in the field sets covered in this section are full-wave, bridge-circuit type with selenium disks, as the rectifying element. They are of rugged construction and are designed to work on various a-c voltages, each producing an output of 115 volts direct current. Chests are supplied for protection during transportation.

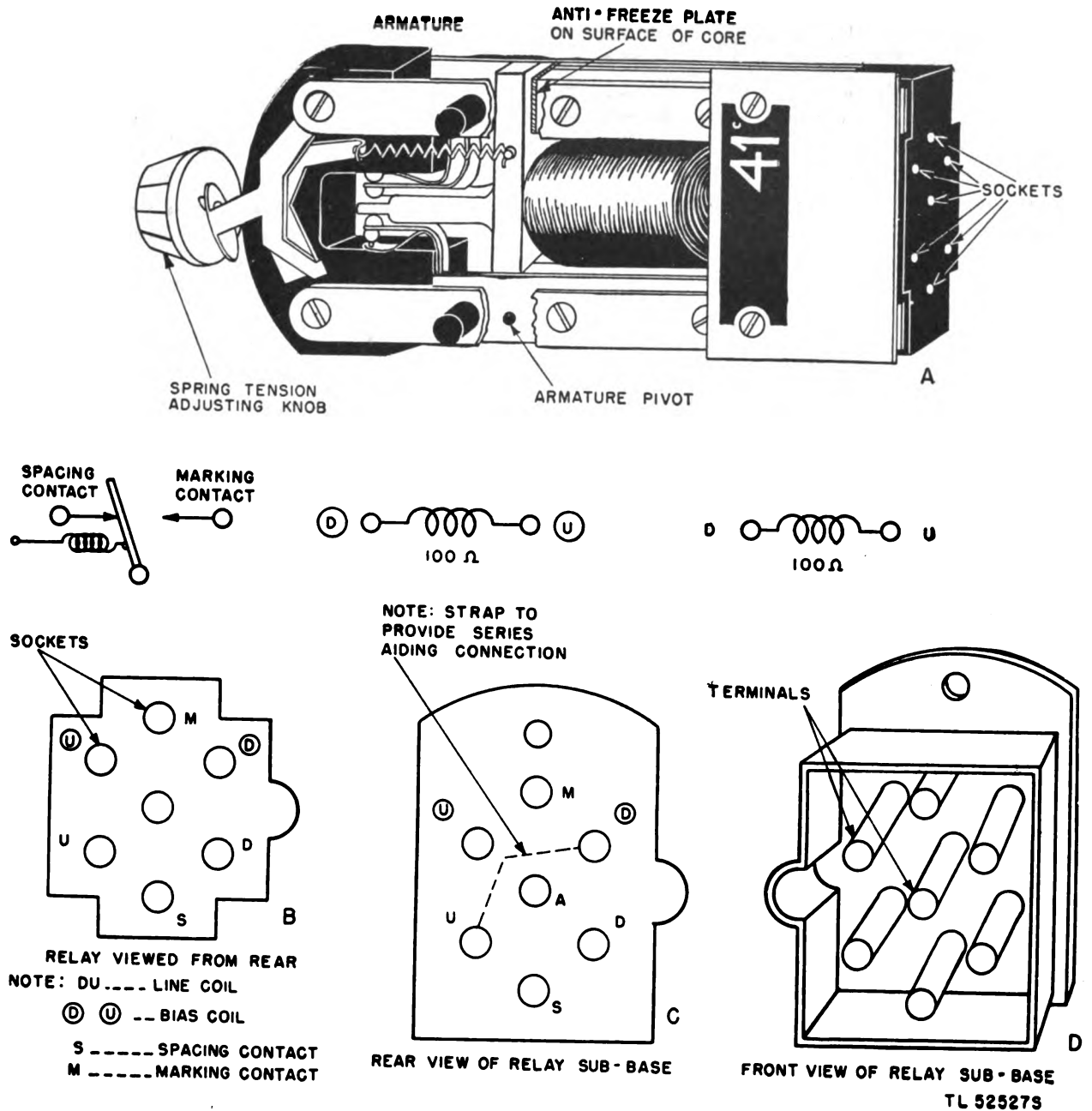

Figure 77. Relay, type 41.

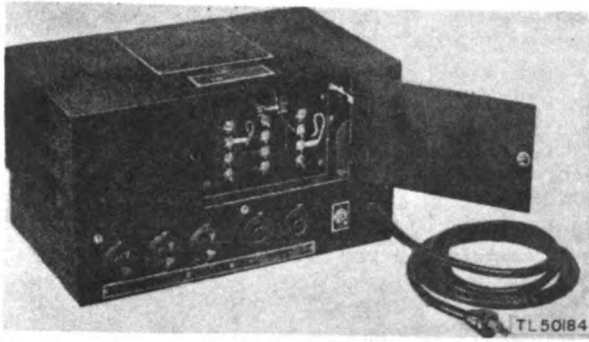

Figure 78. Rectifier RA-87.

a. RECTIFIER RA-87. Rectifier RA-87 operates on 50-60-cycle alternating current, and provides up to 0.400 amp of direct current at 115 volts for the line unit and signal circuit. This rectifier also provides up to 500 watts at 115 volts alternating current for operation of the teletypewriter motor. Taps on the input circuit are adjustable for a-c supply voltages of approximately 95, 105, 125, 190, 210, 230, and 250 volts. The d-c output is adjustable over a range of about 10 volts in three steps. Rectifier RA-87 is built on a welded steel chassis and is completely inclosed by a steel chassis base and a folded hinged door in the front of the tap-changing panel to

facilitate adjusting the transformer taps. (See fig. 78.) In front of the chassis are located three receptacles for connecting a-c loads (7 of fig. 79), two twist-type receptacles for d-c loads (8 of fig. 79), an ON-OFF switch (9 of fig. 79), and a 6-foot attached cord and plug (20 of fig. 79) for connecting to a power source. An instruction plate is located on the top of the chassis cover. Inside the top of the cover are fastened actual and schematic wiring diagrams. A tapped transformer (1 of fig. 79) is bolted on top of the chassis. This supplies alternating current to the receptacles and to a selenium dry-disk rectifying element (3 of fig. 79) bolted to the opposite end. An iron core choke coil and two capacitors (2 and 4 of fig. 79) filter the direct current from the rectifier. The tap-changing panel (6 of fig. 79) provides four rectifier taps, eight primary taps for setting to the proper line voltage, and a fuse block (5 of fig. 79) with a 5-amp fuse for the d-c load. Inside the chassis, below the rectifier, is mounted a bleeder resistor for the d-c supply and a fuse panel with fuse and spare fuse for the a-c load. Rectifier RA-87 is packed in Chest CH-158 for transportation.

b. RECTIFIER RA-37. Rectifier RA-37 (fig. 80) is built on a welded steel chassis and is completely

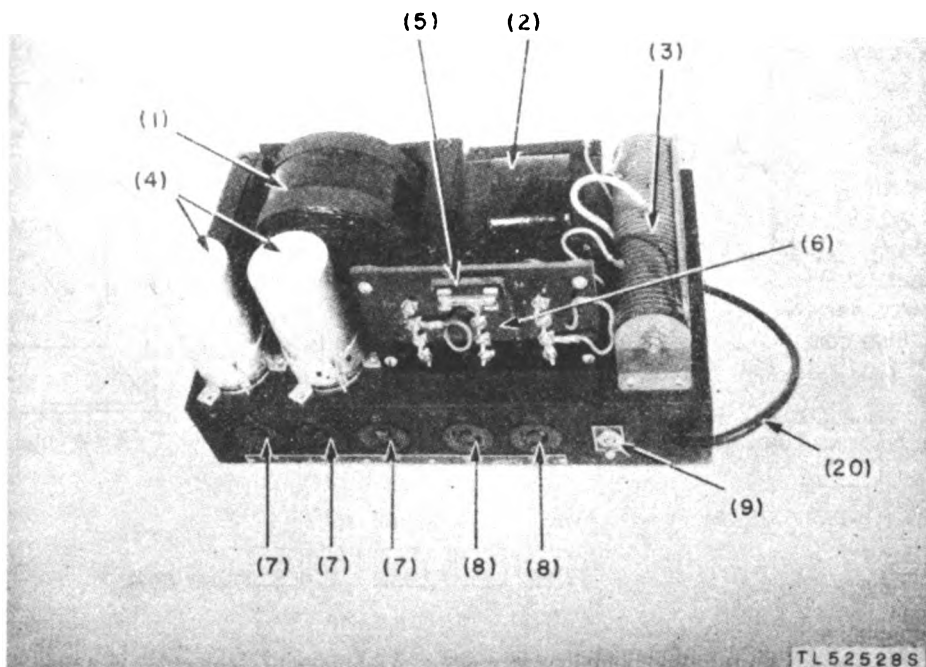

Figure 79. Rectifier RA-87, cover removed.

inclosed by a steel cover finished with a smooth, durable, black paint. The unit contains a 6-foot cord with plug, an ON-OFF switch, a tapped transformer, tap-changing panel, rectifying element, iron-core choke coil, two high-capacity electrolytic capacitors, bleeder resistor, and a twist-type receptacle. The cord with attached plug is used to connect the unit to an a-c power source. The transformer furnishes alternating current to the rectifying element, and the choke coil and capacitors filter the direct current from the rectifying element. The bleeder resistor provides a constant load for the rectifier, preventing the output voltages from rising too high when small d-c loads are used. A tap-changing panel mounted at one end of the power transformer has eight primary taps which can be set in 5-volt steps for power source voltages between 95 and 125 volts. Fuse clips and a 5-amp fuse on the tap-changing panel provide protection for the rectifier against overload. The rectifier operates on 50-60-cycle alternating current and provides up to 0.400 amp of direct current at 115 volts. Rectifier RA-37 is packed for transportation in Chest CH-51.

c. RECTIFIER RA-89. For operation in localities where only 25-40-cycle alternating current is available, Rectifier RA-89 may be issued in place of Rectifier RA-87. Rectifier RA-89 is similar to Rectifier RA-87 in output and input voltages and adjustment characteristics, but operates on 25-70-cycle alternating current. It is somewhat larger and heavier than Rectifier RA-87 and is packed in Chest CH-159. It is not a component of the teletypewriter sets covered in this section.



Figure 80. Rectifier RA-37.

44. Power Unit PE-77-(*)

Power Unit PE-77-(*) (fig. 81) is a gasoline-engine driven generator set capable of furnishing 250 watts of 115-volt d-c power. The generator is

mounted directly on a 3,000-rpm, single-cylinder, air-cooled, 4-cycle L-head engine. Constant speed and output voltage are maintained by an air-vane governor. The units are provided with crate-type carrying cases.

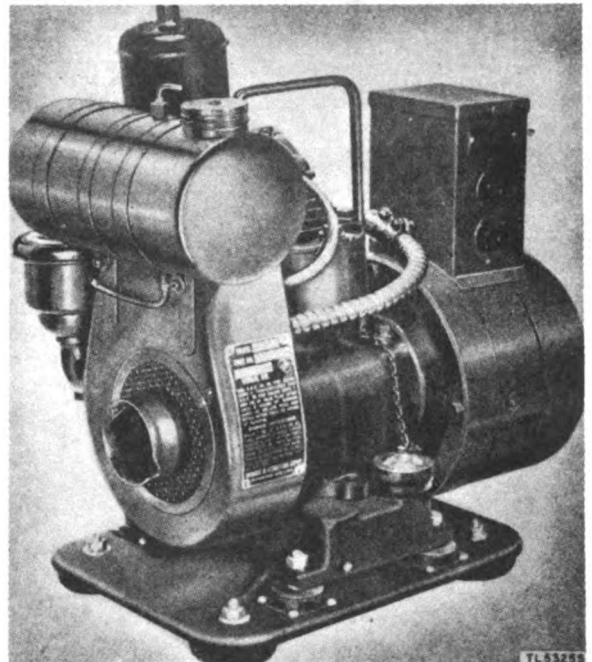

Figure 81. Power Unit PE-77-A.

45. Teletypewriter Sets EE-98 and EE-102

Teletypewriter Sets EE-98 and EE-98-A are intended for use where a source of alternating or direct current is always available. They are identical to Teletypewriter Sets EE-97 and EE-97-A, respectively, with the exclusion of the power unit. Teletypewriter Set EE-102 is identical to Teletypewriter Sets EE-98 and EE-98-A except that Teletypewriter TG-37-B is substituted for Printer TG-7-A or Teletypewriter TG-7-B.

46. Teletypewriter TG-37-B

Teletypewriter TG-37-B is packed in the same kind of a chest, operates on the same kind of power sources, and is otherwise similar to Teletypewriter TG-7-B, except: the keyboard and the type pallets have weather symbols. The machine is arranged to stop the motor automatically when the platen is in the figures position and blank and H signals are received in succession. The machine is adjusted to type a maximum of 76 characters per line, and the carriage return and line feed functions are

inoperative (carriage will space) when the platen is in the figures position.

47. Reperforator Teletypewriter Sets TC-16 and TC-17

Reperforator Teletypewriter Sets TC-16 and TC-17 provide complete portable sending and receiving teletypewriter stations for field use. (See fig. 82.) These sets consist essentially of a typing tape reperforator with keyboard and transmitter distributor. These are adapted for use on 60 ma neutral networks or for point-to-point communication. Facilities are provided for operating this equipment in

conjunction with one or two of the field sets. The reperforator transmitter included in the sets covered by this section consists essentially of a modified teletype model 14 transmitter distributor. Both units are anti-shock mounted on a common wooden base and protected in transportation by a wooden cover which serves as a table for the units when they are prepared for operation. (See fig. 83.) The components of Reperforator Teletypewriter Set TC-16 are: Reperforator Transmitter TG-26-A, Rectifier RA-87, Line Unit BE-77-A, and a group of accessories and running spare parts, and two ground rods. Reperforator Teletypewriter Set TC-17 has like components excepting that Reperforator Transmitter TG-27-A is substituted for Reperforator Transmitter TG-26-A.

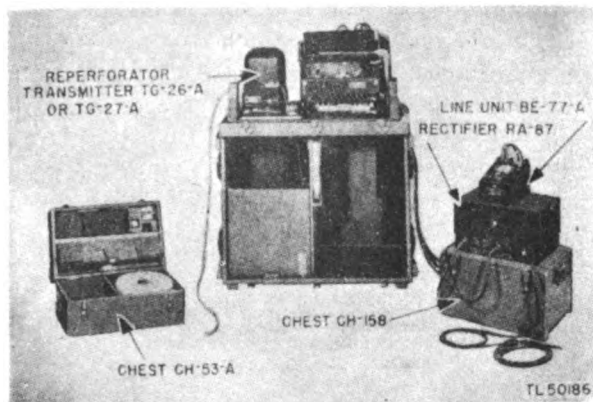

Figure 82. Reperforator Teletypewriter Set TC-16 or TC-17.

48. Reperforator Transmitters TG-26-A and TG-27-A

Reperforator Transmitter TG-26-A consists of a sending-receiving typing reperforator, transmitter distributor, connection box, and chest. The typing reperforator and transmitter distributor are secured to the base of the chest with anti-shock mounts, and the covers of these two units latch to their respective bases. The chest cover, when removed and placed on its side, provides a support for the chest base with operating equipment. Hinged panels within the cover may be swung into position to form a storage compartment for perforated tape that may accumulate between the typing reperforator and transmitter distributor. (See fig. 83.) The typing reperforator may be used to transmit directly to the line and monitor the message by printing on and perforating tape. When tape transmission only is desired, the typing reperforator may be operated locally and the tape thus perforated used for operating the transmitter distributor. The typing reperforator may also be connected to the circuit to receive signals from a distant point to prepare tape for retransmission. The connection (jack) box (fig. 84) is equipped with two power cords with plugs, one for the motor power and the other for local direct current; two receiving line cords with plugs, and two sending line cords with plugs (send and receive for line 1; send and receive for line 2) which are inserted into the line unit jacks for connection to signal lines. Each of these send and receive cords is wired in series to a pair of jacks mounted in the jack box. The typing reperforator is equipped with two line cords with plugs (send and receive) and the transmitter distributor with one (send).

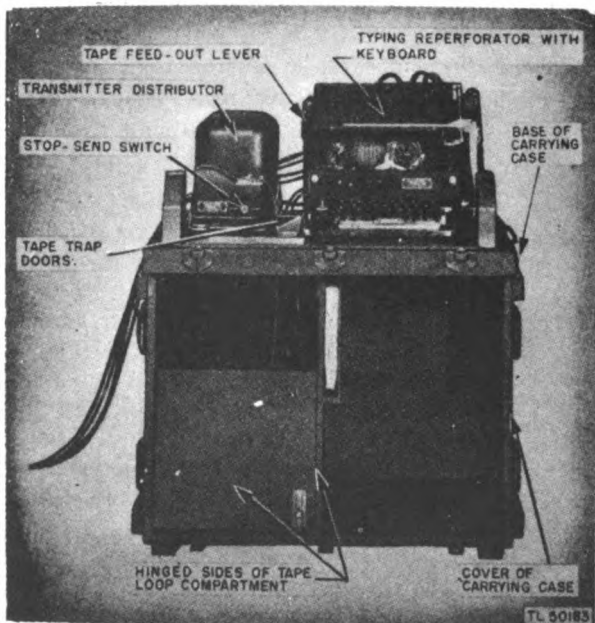

Figure 83. Reperforator Transmitter TG-26-A, front view.

The plugs may be inserted into the connection box jack for connection to the signal lines. The governed series motors require 115-volt, 225-watt source of either direct current or 25-40-cycle or 50-60-cycle alternating current. It is preferable to operate the motors on alternating current although satisfactory motor operation may be obtained on any stable voltages (alternating or direct current) between 105 and 125 volts. The local operating circuits of the jack box require a 105-125-volt, 25-watt source of direct current. A power-selector switch (fig. 84) is mounted on the right-hand side of the jack box. This switch together with suitable resistances located within the jack box permits operation of the motors on various sources of power. Reperforator Transmitter TG-27-A is similar to Reperforator Transmitter TG-26-A except that the keyboard key tops and typebar pallets have weather type symbols, and the end-of-the-line indicator is adjusted to operate when approximately 69 characters have been perforated.

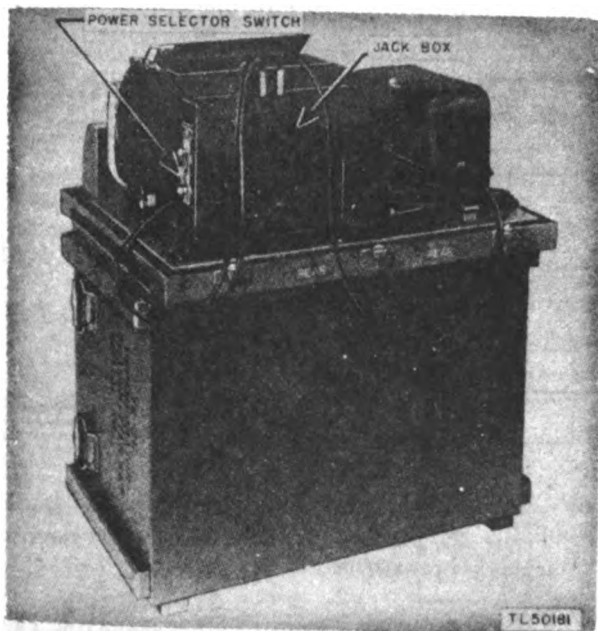

Figure 84. Reperforator Transmitter TG-26-A, rear view.

49. General

Installation of field teletypewriter sets generally consists of the selection of a suitable station location, setting up the equipment, making power source and signal line connections, and line-up procedure. Select a dry, covered location, with provisions for blackout operation, at or near the station to be served. A location with a suitable commercial or military source of

power is required for Teletypewriter Sets EE-98, EE-98-A, EE-102, and Reperforator Teletypewriter Sets TC-16 and TC-17 and is preferred for Teletypewriter sets EE-97 and EE-97-A.

50. Location of Equipment

When a suitable location for the teletypewriter set has been chosen, consider setting up the various component parts of the set in a practical order. Because location of the component parts of teletypewriter equipment in the field depends upon the conditions encountered, no standard clearances, etc., are used as in fixed-station installation. The installer keeps in mind that all equipment must be located to give maximum opportunity for maintaining and operating the equipment within the available space. The operator must be provided with the best lighting facilities possible. Figure 85 shows an efficient and practical method of arranging the components of Teletypewriter Set EE-98-A. A minimum amount of space is used, and the components are readily available to the operator. When a power unit is used, select a level surface so that the unit will rest evenly and solidly on the ground or the floor. If the unit is to be operated indoors, there must be free circulation of air because exhaust fumes from the gasoline engine are extremely dangerous if discharged in a closed room; however, they are harmless if mixed with plenty of fresh air. In addition to piping the engine exhaust to the outside of the building, amply ventilate the room to carry away any leaking exhaust fumes. There must be a free enough circulation of air to allow proper cooling of the engine. When the engine room is relatively small, air can be forced to circulate within it by

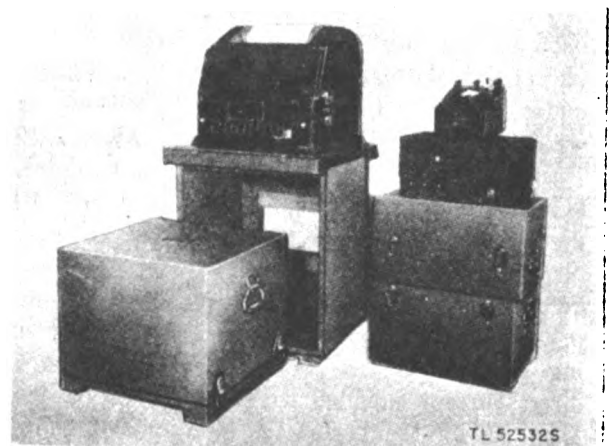

Figure 85. Teletypewriter Set EE-98-A.

means of a fan. This allows air to prevent overheating and provides for combustion.

51. Power Source Connections

Determine voltage and frequency of power sources before making connections to them. When gas-engine power units are used, the data giving this information may be obtained from nameplates on the units. When the sources are commercial or military, the agency furnishing the power can generally supply the necessary information. If the information desired is not available from these sources, voltage and frequency data frequently can be learned from the nameplates of equipment already connected to the power sources. D-c voltages can be measured by Line Unit BE-77-A. Its meter will give a small vibrating indication about the zero point on 25-cycle a-c voltage. On 60-cycle alternating current, the meter needle will move for an instant, then return to zero.

a. CONNECTIONS TO TELETYPEWRITER SETS EE-97(*), EE-98(*), AND EE-102. Connect the power cords of the teletypewriter, line unit, and rectifier for operation of field sets on the usual 115-volt 50-60-cycle a-c power source as shown in figure 86. When Rectifier RA-37 is first installed, place the transformer taps on the maximum voltage position (125). When the taps are set, connect the input power and turn it on. The output voltage can be tested by connecting the line unit to the receptacle on the rectifier and holding the METER key of the line unit to VOLTS. If the meter shows less than 115 volts, change the taps on the rectifier until 115 volts is indicated on the meter. Figure 87 shows the power cording connections when Rectifier RA-87 is used with a power source of 85 and 135 or 170 to 270 volts, 50-60-cycle alternating current. The connections are the same as with Rectifier RA-37, except that alternating current for the printing unit motor is obtained from the rectifier a-c receptacle which furnishes 115 volts alternating current. When Rectifier RA-87 is first installed, set the primary lead on the maximum voltage position (250). After the primary lead is set, test the output in the same manner as when Rectifier RA-37 is used. If the output voltage is incorrect, change it by moving the primary lead to another terminal. The power cording connections for the different field sets with direct current supplied commercially or by Power Unit PE-77(*) are shown in figure 88. Test the voltages by the line unit and, if a power unit is used, adjust them by the governor under full load (tele-

typewriter motor running). SET THE TELETYPEWRITER POWER-SELECTOR SWITCH AND THE RECTIFIER VOLTAGE TAPS FOR THE POWER TO BE USED BEFORE TURNING ON THE POWER. To avoid possibility of electrical shock to operating personnel, and to reduce interference from the motor circuit, connect an earth ground to the frame of the teletypewriter. Never make such a connection to the same ground for a ground-return signal circuit unless it is a low resistance connection such as a water pipe.

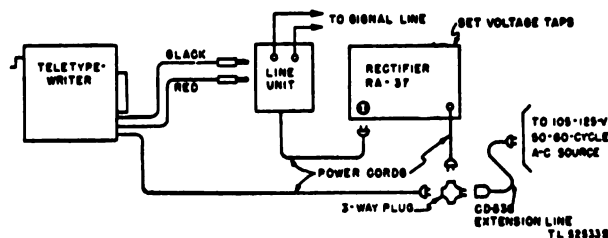

Figure 86. Cording connections of Teletypewriter Set EE-97-(*), EE-98-(*), or EE-102, when Rectifier RA-37 is used.

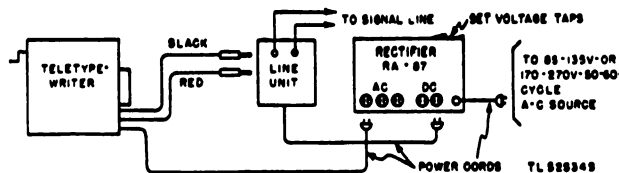

Figure 87. Cording connections of Teletypewriter Set EE-97-(*), EE-98-(*), or EE-102, when Rectifier RA-87 is used.

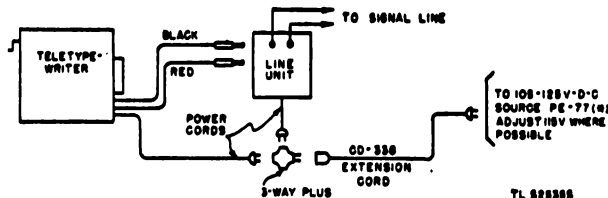

Figure 88. Cording connections when direct current is supplied commercially or by Power Unit PE-77-(*).

b. POWER CONNECTIONS TO REPERFORATOR TELETYPEWRITER SETS TC-16 AND TC-17. For operation on the usual 115-volt d-c or 50-60-cycle a-c power source, the power cords of the reperforator-transmitter, and of the line units and rectifier when required, are connected as shown in the applicable part of figure 89. When more than one line unit is needed as shown in A, B, and C of figure 89, these additional line units (indicated by dotted lines) should be connected to secondary sources of d-c power to avoid cross-fire effects between the lines. Secondary sources of d-c power could be another

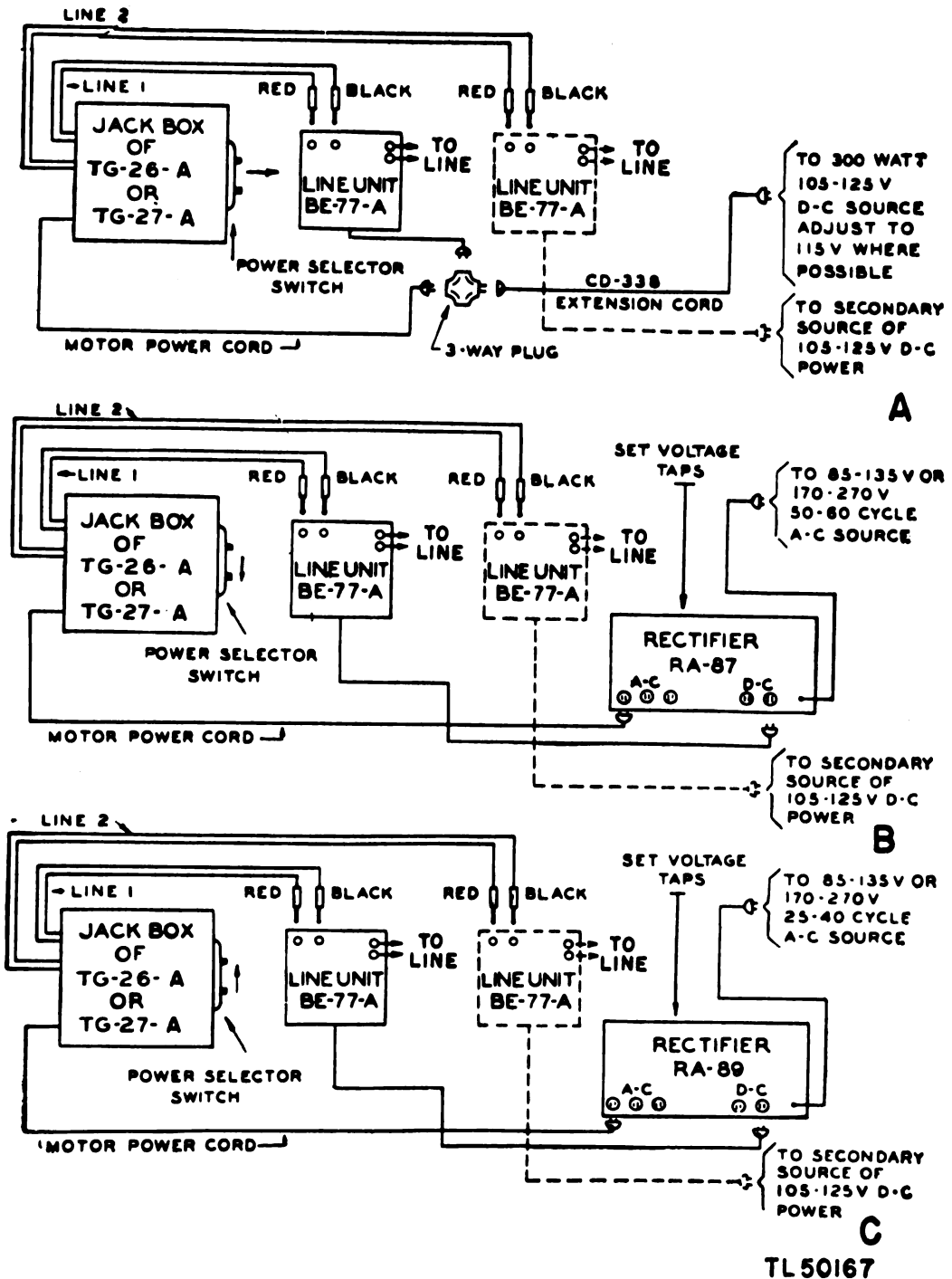

Figure 89. Cording connections for Reperforator Teletypewriter Set TC-16 or TC-17.

Rectifier RA-87 or RA-89, a Rectifier RA-37, or a Power Unit PE-77-(*), one or more of which may be available if field teletypewriter sets are operated in conjunction with a reperforator teletypewriter set. In any event, do not connect more than one line unit to one Rectifier RA-87 or RA-89. When two line units are to be connected to a common d-c power source, the connections must be poled properly before the ground wire is attached to the GND binding post to prevent short-circuiting the power supply. The proper polarity is obtained by connecting the power cords so that the meters of both line units deflect in the same direction (to the right) when the polarity is checked by throwing the METER key of the line unit to the voltage position. When it is necessary to supply d-c power to the local circuits of the jack box, the d-c power cord from the jack box may be connected to any source of 115-volt direct current provided. However, if the source is a rectifier, do not connect more than one line unit to the rectifier in addition to the d-c power cord of the jack box. The power-selector switch on the right-hand side of the jack box, and the rectifier input voltage taps must be set for the type and voltage of the power source to be used before the power is turned on. Connect a separate protective ground to the binding post marked EARTH CONNECTION on the lower left-hand side of the jack box.

52. Signal Circuit Connections and Line-up

For efficient connection and line-up of signal circuits, a definite procedure must be followed by installers at each end of a circuit. Check all equipment locally before the connection to the signal line is made. Line-up of a circuit will ordinarily consist of arranging for the line current supply, adjusting the line current, and adjusting the relays at each end of a circuit prior to completion of the circuit line-up. Usually, it will be necessary to carry on communication by means of break signals which can be observed on the line unit meter. The line-up of a circuit is controlled by the station at higher headquarters unless for some exceptional reason there are contrary orders. When the circuit is between two stations of equal authority, the station bearing the lower numerical designation is the control station. The following subparagraphs describe the line-up procedure as performed between two stations (non-control terminal and control terminal).

a. SIGNAL CIRCUIT CONNECTIONS OF TELETYPEWRITER SETS EE-97-(*), EE-98-(*), AND EE-

102. The local signaling circuit (machine-to unit) is made by inserting the machine send and receive plugs (black and red) into their respective jacks in the line unit. The binding posts marked LINE and GND are located on the top of Line Unit BE-77-A and are used to connect the signaling circuit. (See fig. 90.) If the line unit is to supply line current on a ground-return circuit, connect the line wire to the terminal marked LINE and the ground wire to the terminal marked GND. If the line unit is not to supply line current, reverse these connections in order to keep the meter reading to the right. In this way, series-aiding battery may be obtained simply by operating the switch to LOCAL CURRENT SUPPLY. Normally, the signaling circuit is completed at the line unit relay which repeats the signals to the machine through the send and receive cords, plugs, and jacks. If the machine is not equipped with these cords and plugs, connect the send and receive circuits of the machine to the four binding posts made available for that purpose. The straps across these binding posts *must* be removed unless cords and plugs are used on the teletypewriter. Handle all line wires carefully; voltage may be applied at the distant station. Always test equipment locally before connecting the signaling line. When connecting the equipment for local check, place a strap across the two signal terminals after the rheostat is turned to all resistance (IN). Then throw the switch on the line unit to LOCAL CURRENT SUPPLY and adjust the rheostat for 60 ma. Throw the switch which controls the line unit relay to RELAY OUT OF CIRCUIT; then test and orient the machine. Then place the relay control switch to RELAY IN CIRCUIT and type R's and Y's on the teletypewriter to test the line unit. If the machine does not print properly, adjust the white relay knob until proper printing results. It is not practicable to test single ground connections to water pipes and similar objects. If there is doubt about such a connection, install a ground rod or other separate ground, and test by connecting a field wire pair to the earth connection and to the line and ground binding posts. When the local operation has been checked, connect the jumper wire between the binding posts so that it can be easily removed and applied without danger of shock. The installer should watch the meter and observe the indication when the jumper is removed. If the meter indication changes from 60 ma to any value above 39 ma when the jumper is removed, the ground connection is satisfactory (less than 240 ohms). If the meter

indicates a value of 39 ma or less, a better ground must be obtained. Then remove and discard the jumper and remove both wires of the field wire pair connected to the ground binding post. If line current is to be supplied by the distant station, cut out all resistance at the rheostat and connect the signal line to the terminal marked LINE. All resistance should be IN if the line unit is to supply line current.

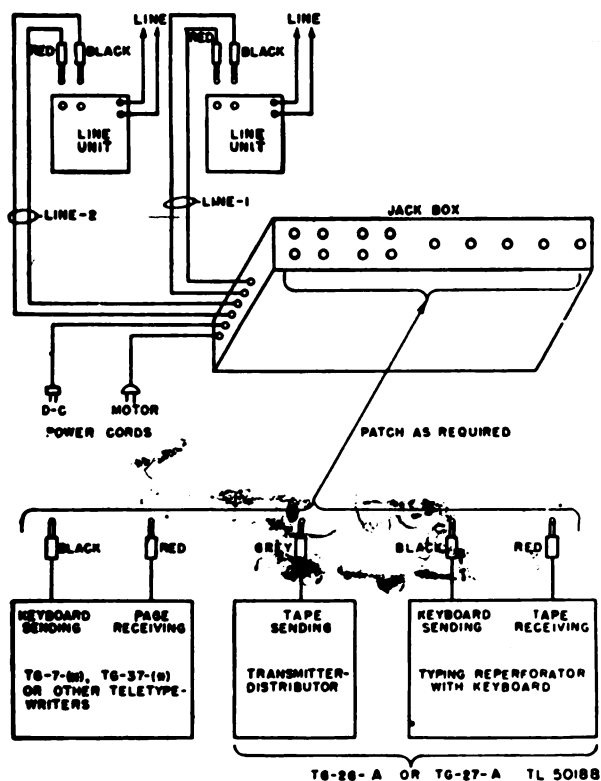

Figure 90. Signal circuit connections of Reperforator Teletypewriter Set TC-16.

b. SIGNAL CIRCUIT CONNECTIONS FOR REPERFORATOR TELETYPEWRITER SETS TC-16 AND TC-17. Usually, Teletypewriter Set EE-98-(*) is used with Reperforator Teletypewriter Sets TC-16 and TC-17. Line units are connected and tested exactly as they are with the field sets. The local signaling circuits differ in that these connections for the TC-16 and TC-17 sets are made flexible by use of the connection (jack) box of the typing reperforator. The jack box allows various operating combinations to be established without disturbing any connections made to the line units. The jack box contains circuits, each of which has one end provided with a plug for connections to the respective line unit jacks. The other ends of the circuits are provided with jacks which furnish means for connecting the typing reperforator, transmitter distributor, and Teletype-

writer TG-7-B, singly or in various combinations, to either or both lines. To send and receive, plugs of the connection box are inserted into their respective jacks of the line units (fig. 90); this completes the signal circuits to the jack box. The send and receive plugs of both machines and the plug of the transmitter can then be inserted into the jacks and receive plugs of both machines and the plug of the connection box for the desired combination.

c. LINE CURRENT ADJUSTMENT. When a station is to supply line current, either as a control terminal or otherwise, the right-hand toggle switch on the line unit is placed at LOCAL CURRENT SUPPLY. Place the arrow on the rheostat at IN when the switch is thrown. When the station is a noncontrol station and does not supply line current, place the right-hand toggle switch of the line unit at DISTANT CURRENT SUPPLY. The station installer at the noncontrol station checks to see that the right-hand toggle switch on his line unit is at DISTANT CURRENT SUPPLY and that the arrow on the line unit rheostat is at OUT. He then watches the meter for signals from the control station. The installer at the control station turns the rheostat toward OUT until the meter reads 75 ma, and sends two 5-second break signals, indicating what has been done. If the resistance is too high and 75 ma cannot be obtained, the control station sends as much current as possible before transmitting two 5-second break signals. When the meter at the noncontrol station indicates two break signals, the installer decreases the line current from about 75 ma to 60 ma with his line rheostat. If the line current is already between 50 and 60 ma, he makes no such adjustment but proceeds with the adjustment of line relays. If the line current is below 50 ma, he arranges to supply battery to the line by cutting all resistance in and throwing the toggle switch to LOCAL CURRENT SUPPLY. He then adjusts the line current to 75 ma and sends two 5-second break signals to notify the control station to adjust the line current to 60 ma. After the line current is adjusted to as near 60 ma as possible, the installer at the control station sends two 5-second break signals to indicate that his adjustments have been made. If the procedure results in current between 35 and 50 ma, the line can usually be made to operate satisfactorily and its line-up should be completed.

d. RELAY ADJUSTMENT. When the installer at the noncontrol station has cut the current to 60 ma, he immediately sends repeated space signals to the control station allowing its relay to be biased. The

control station attendant then adjusts his relay for zero bias, sends two 5-second break signals, and immediately sends space repeat signals to the non-control station. When the noncontrol station receives these break signals, the attendant adjusts the line unit relay for zero bias by holding the METER key at BIAS (to the right) and turning the relay knob until the vibrations in the meter needle center at zero on the meter scale (zero bias). After zero bias is obtained, the METER key is released and two 5-second break signals are sent to the control station. NEVER HOLD THE KEY AT BIAS UNLESS REPEATED SPACE SIGNALS ARE RECEIVED.

e. TEST COPY. After the relay at each end is adjusted, test copy can be sent from the noncontrol station to the control station and vice versa, using breaks for signaling. Receipt of accurate copy at both ends indicates that the line-up is satisfactory and that the circuit is ready to handle traffic.

f. EMERGENCY ARRANGEMENTS. It may not be possible to adjust the line relay for zero bias on very short lines. However, satisfactory operation can often be achieved by adjusting the relay to as near zero bias as possible. When a relay is found to be damaged or defective and no replacement can be obtained, satisfactory operation can sometimes be obtained over short lines by throwing the left-hand toggle switch to RELAY OUT OF CIRCUIT. Recheck the line current to be sure that it is 60 ma. When a suitable source of direct current is not available, it is sometimes possible to obtain satisfactory operation over short lines by throwing the toggle switches to RELAY OUT OF CIRCUIT and DISTANT CURRENT SUPPLY. If a bias meter is not obtainable, R's and Y's can be requested; turn the adjusting knob of the relay to the right until errors are received by the teletypewriter and then turn it to the left until errors appear; at the same time count the number of turns. Then turn the knob back to the right, half way; this will adjust the relay to as near zero bias as it is possible to get such an adjustment without a bias meter. Orient the machine on the repeated signals. After the line unit is lined up on a particular line circuit, it requires only the occasional checks listed below:

(1) Checking the line current to see that the reading has not changed, and, if it has, readjusting it.

(2) Checking received copy for errors, and, if any are found, readjusting the line relay.

(3) Checking the relay adjustment if the line

condition has changed after the original adjustment, even though accurate copy is received. Line conditions change with changes from dry to wet weather and between night and day temperature and humidity conditions.

(4) Checking both line current and relay adjustment if the line circuit has not been operated for more than a few hours.

53. Functioning of Parts of Field Teletypewriter Equipment

Field servicing, such as changing relays, replacing fuses, tightening loose parts, and keeping the unit clean, normally is done by the operator. Repairs and adjustments within the equipment will be made only by qualified maintenance personnel. In order to make the internal repairs and adjustments, it is necessary that the maintenance man know the circuits and operation of the line unit, power-selector switches, and jack box of Reperforator Transmitters TG-26-A and TG-27-A.

54. Operating Circuits of Line Unit BE-77-A

The complete schematic circuit of Line Unit BE-77-A is shown in figure 91. All terminals on the diagram of Line Unit BE-77-A marked (+) and (-) are actually connected to positive and negative leads of the d-c power source.

a. LINE CIRCUIT. In the usual method of operation, the relay is in the circuit and the line current is supplied by a switchboard (toggle switches are on RELAY IN CIRCUIT and DISTANT CURRENT SUPPLY). The normal line circuit is illustrated in figure 92. The positive side of the switchboard power is grounded. Therefore, to keep the meter reading to the right of zero, the nongrounded (negative) side is connected to the ground terminal. In tracing the circuit, these terminals can be considered as positive and negative battery. Starting at the LINE terminal, the circuit goes through the $\frac{1}{4}$ -amp fuse, the 0-2,500-ohm LINE RHEOSTAT, the 1.01-ohm resistor, the relay winding, the transmitting contacts, and the ground terminal. Because the transmitting contacts at the distant station are in series with the relay of line unit, they are able to send to the relay by making and breaking the circuit. The transmitting contacts of the local station are also in series with the relay of the line unit, allowing home copy to be printed. The blown-fuse indicator is a neon lamp which is connected directly across the $\frac{1}{4}$ -amp fuse. The fuse acts as a shunt around the neon lamp, keeping the lamp from lighting except

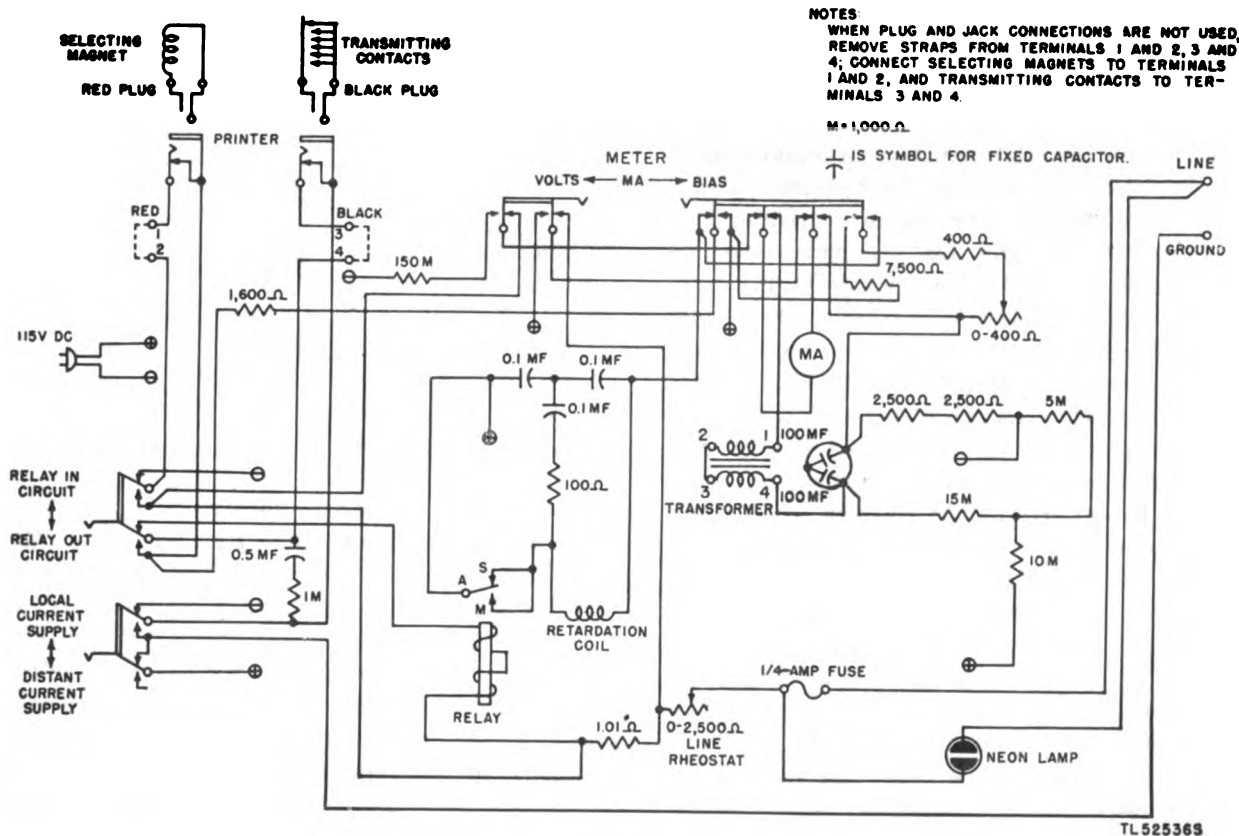

Figure 91. Line Unit BE-77-A, schematic diagram.

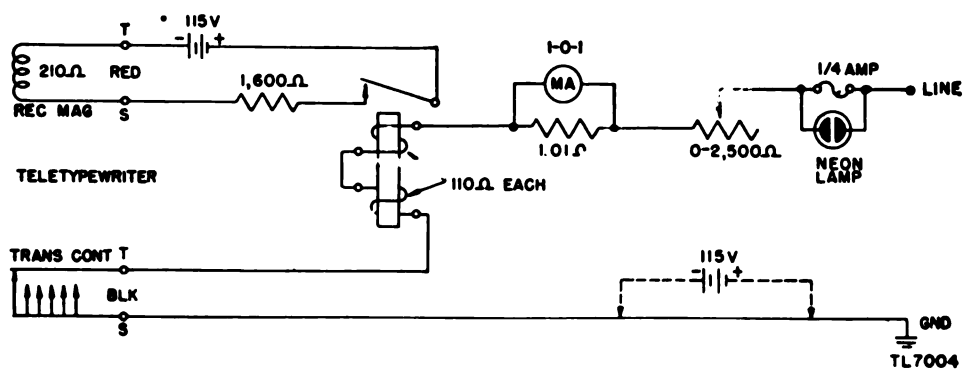

Figure 92. Line Unit BE-77-A, simplified normal operating circuit.

when the fuse is blown. At that time voltage will be applied to the lamp, causing it to glow.

b. SELECTOR MAGNET CIRCUIT. When the transmitting contacts of either the local or distant teletypewriters operate, the line unit relay is caused to make and break the circuit to the local teletypewriter's selector magnets. This circuit is shown in figure 93 with the relay armature in marking position. The circuit goes from the terminal marked (+) through the relay armature and marking contact, the retardation coil, and the meter-switching key, through the 1,600-ohm resistor to the relay control switch to the terminal marked (-). Because the relay armature is in series with the receive jack, the operation of the armature will cause the selector magnet of the teletypewriter to respond accordingly if the machine receive plug is inserted into the jack. The retardation coil works in conjunction with capacitors to suppress radio frequency. The current flow is limited by the 1,600-ohm resistor and the resistance of the magnet coils (105 ohms each). Much of the distortion which may be present in incoming signals can be removed from the repeated signals by the proper adjustment of the line relay biasing spring. If the spring tension is increased (pulling the armature away sooner), the length of the repeated marking signal is made shorter; if the tension is decreased, the repeating marking signal is lengthened.

c. LINE CIRCUIT WITH RELAY OUT. When it be-

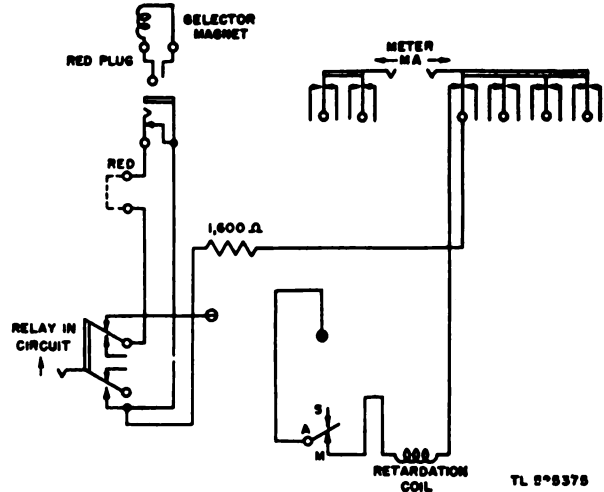

Figure 93. Line Unit BE-77-A, selector magnet circuit.

comes necessary to operate without the use of the relay, set the toggle switch to RELAY OUT OF CIRCUIT. The transmitting contacts of both the local and the distant stations are connected in series with the selector magnet. (See fig. 94.) When this type of operation is used, the removal of the relay will not affect operation of the circuit. The circuit goes from the line terminal (positive), through the fuse, rheostat, and shunt resistor to the relay control switch. From the switch, the circuit continues up through the receive jack and back to the relay control switch, up through the send jack, back through

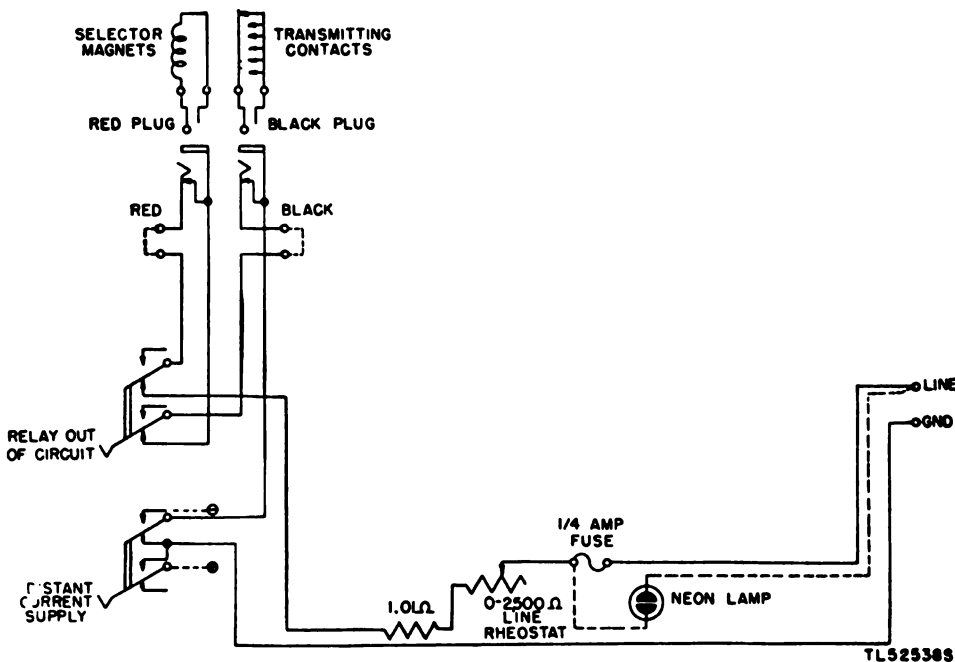

Figure 94. Line circuit with relay out.

the line current switch and to the terminal marked GND (negative). No local power source is necessary when the line unit is used in this type of operation.

d. LINE CURRENT MEASUREMENT. The meter in Line Unit BE-77-A indicates the line current of either polarity unless the switch is held in the VOLTS or BIAS position. The meter shunt for the line unit is permanently wired into the line circuit. For a full-scale reading (a line current of 100 ma), 99 ma go through the 1.01-ohm shunt and 1 ma goes through the meter. The milliammeter circuit is in parallel with the 0.01-ohm resistor in the line circuit as shown in figure 95. Because the meter circuit offers a much greater amount of resistance than the 0.01-ohm resistor, most of the line current will not go through the circuit shown but will go through the resistor. Starting at the positive side of the 0.01-ohm resistor, the circuit goes through the contacts of the METER key, through the meter to other contacts of the METER key, down to the relay control switch, and to the negative side of the resistor. The only controlling switch is the meter-switching key.

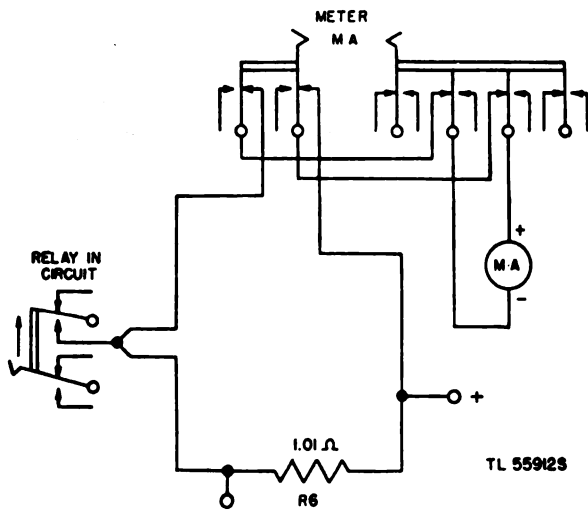

Figure 95. Line current measurement circuit.

e. VOLTAGE MEASUREMENT CIRCUIT. When the METER key is held in the VOLTS position, the meter is disconnected from the line current shunt resistor and connected in series with a 150,000-ohm resistor and the line unit d-c. power supply. A d-c voltage of 115 volts will then give a reading of 115 on the meter scale (center red mark of either group of three red marks). The voltage measurement circuit is shown in figure 96. The circuit goes from positive battery through the contacts of the METER

key, through the meter, other contacts of the METER key, and through the 150,000-ohm resistor to negative battery.

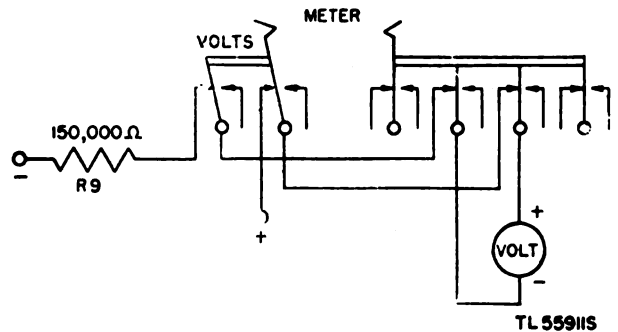
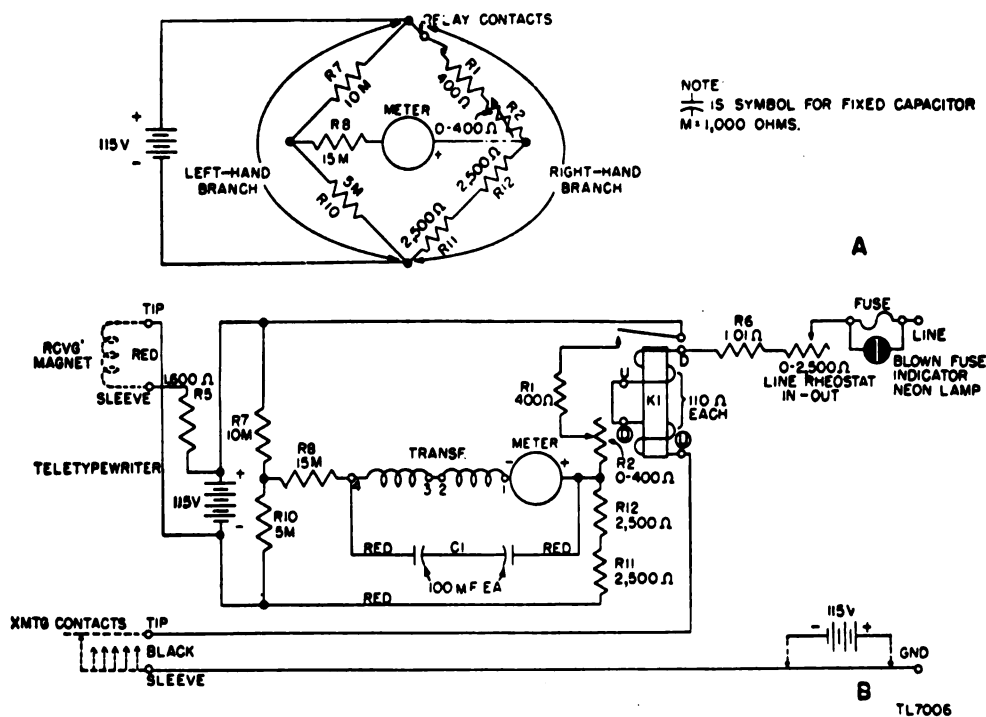

Figure 96. Voltage measurement circuit.

f. BIAS MEASUREMENT CIRCUIT. (1) When the METER key is thrown to BIAS, a local circuit is arranged as a bias-measuring circuit. (See fig. 97.) The meter is connected into the circuit. The line current remains unchanged except for the removal of the meter from connection across the line current shunt resistor. The teletypewriter selector magnet is connected to the d-c power supply through the 1,600-ohm resistor and thus receives no signals while bias is being measured. By adjusting the tension of the armature spring on the line relay, it is possible to obtain signal impulses of standard length (zero bias) in the local circuit when the relay is actuated by line impulses having considerable distortion. Line signals are distorted principally by line circuits over which they are transmitted, and the relay must be adjusted to the characteristics of each line to which it is connected.

(2) The line relay can be adjusted to compensate for line signals having marking bias by increasing the spring tension on the relay armature. When this tension is increased, the contacts close a little later and open a little earlier on each current impulse through the line relay winding. Likewise, spacing bias can be counteracted by reducing the spring tension of the armature.

(3) The bias-measuring circuit in simplified form is shown in A of figure 97. The circuit is designed so that when the relay contacts apply repeated space signals with current impulses of standard length to the left-hand branch of the circuit, the meter indicates zero bias. This circuit is balanced when the average current through the left-hand branch equals the current through the right-hand branch. When the relay contacts are open or closed, a circuit exists from negative battery, splitting at the 5,000-ohm resistor (R10) and the 2,500-ohm resistor (R11),



and going through the 10,000-ohm resistor (R7) to positive battery. The other side of the circuit goes through the two 2,500-ohm resistors (R11 and R12), through the meter (+ to - terminal), through the 15,000-ohm resistor (R8), the 10,000-ohm resistor (R7) to positive battery.

(4) The current flows through the meter in such a direction as to cause the meter needle to move to the left. When the relay contacts are closed (marking impulse), another path to positive battery is provided forming two more circuits. One is from negative battery, through the 5,000-ohm resistor (R10), the 15,000-ohm resistor (R8), the meter (- to + terminals), the 0-400-ohm rheostat, the 400-ohm resistor (R1), and the relay contacts to positive battery. The other is from negative battery through the two 2,500-ohm resistors, the rheostat, the 400-ohm resistor (R1), and the relay contacts to positive battery. The current flows through the meter in such a direction that it causes the meter needle to move to the right of zero and is greater than the current attempting to flow through the meter in the opposite direction. Therefore, when zero bias is present, the alternation of current through the meter causes the meter needle to oscillate at zero. If, however, the relay contacts remain closed longer (marking bias), the current flow through the meter in one direction averages a greater

amount than the current flow in the opposite direction. This causes the meter to oscillate at some point to the right of zero. If, however, the relay contacts remain closed longer (marking bias), the current flow through the meter in one direction averages a greater amount than the current flow in the opposite direction. This causes the meter to oscillate at some point to the right of zero, indicating the marking bias. The opposite is true if the relay contacts remain closed for a short period. The 15,000-ohm resistor (R8) in series with the meter protects the meter from overload. The transformer (used as a choke) and the capacitors provide for a steadier meter reading by damping (slowing up) the meter needle.

55. Power-selector Switches of Printer TG-7-A and Teletypewriter TG-7-B

a. Because 60-cycle alternating current produces greater inductive reactance than 40-cycle or 25-cycle, or direct current, less resistance is needed to obtain a definite amount of current flowing in a circuit. As the number of cycles decreases, the inductive reactance decreases, necessitating an increase in resistance. The motor circuit is designed for 60-cycle a-c current, and, when current of lower frequency is used, more resistance must be added to the

motor circuit. On the side of Printer TG-7-A and Teletypewriters TG-7-B and TG-37-B are resistor banks that permit, by means of a switch, the motor circuit to operate on more than one frequency alternating current or on direct current. Figure 98 shows the wiring of these resistor assemblies. The teletypewriter mechanic must know the operation of the resistor banks in case trouble occurs within the motor circuit.

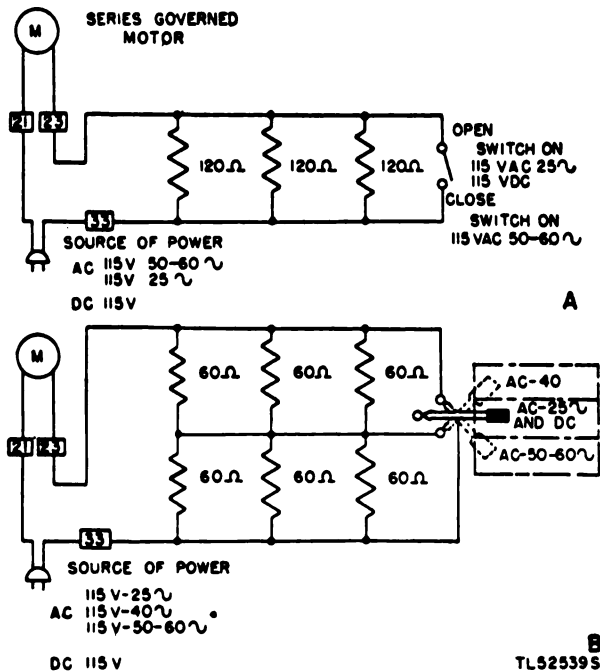

Figure 98. Power-selector switches of Printer TG-7-A and Teletypewriters TG-7-B and TG-37-B.

b. A of figure 98 shows the resistor bank of Printer TG-7-A positioned for d-c or 25-cycle a-c operation (upper). When the switch is in this position, the current flows through the three 120-ohm parallel resistors which insert 40 ohms resistance in the motor circuit. When the switch is set for 60-cycle current (lower), it shorts out the three resistors; therefore, no resistance is inserted into the motor circuit. The resistor bank of Teletypewriter TG-7-B is shown in B of figure 98 with the switch set for d-c or 25-cycle a-c operation. When the switch is in this position (center), the current to the motor flows through the three 120-ohm parallel resistors just as in Printer TK-7-A. If the switch is set for 60-cycle a-c operation (lower), the resistance is shorted out as in Printer TG-7-A. One more switch position is provided on the resistor bank of Teletypewriter TG-7-B. This position (upper) permits motor operation on 40-cycle alternating cur-

rent by inserting one-half of each resistor in parallel for a total of 20 ohms. This same resistor bank is used on Teletypewriter TG-37-B.

56. Connection Box of Reperforator Transmitters TG-26-A and TG-27-A

A jack box, or connection box is mounted on the base of the rear of the typing reperforator. (See fig. 99.) This makes it possible to arrange the typing reperforator, transmitter distributor, and available teletypewriters in a variety of operating combinations. Figure 100 is a schematic circuit diagram of the connection box. It provides two circuits for local operation and two circuits for operating over two individual lines. Line cords are terminated in black shell and red shell plugs for connection to line units. A three-position power-selector switch is mounted on the side of the jack box. This switch, together with suitable resistance located within the jack box, allows operation of the motors on various sources of power. Fusetrans for both the reperforator and transmitter-distributor motor circuits are located in the jack box at the upper left-hand side. To lessen the possibility of electrical shock to operating personnel and to reduce interference to radio receivers from the motor circuits, an earth connection is made to the binding post marked EARTH CONNECTION on the lower left-hand side of the jack box.

a. LOCAL CIRCUITS. The two circuits for local operation that are provided by the jack box mounted on the base to the rear of the reperforator are shown in figure 100. Local circuit 1 consists of three closed-circuit jacks wired in series with a fixed 1,600-ohm resistor. Local circuit 2 is similar to circuit 1 but includes only two jacks. Fixed resistors limit the current in each circuit to approximately 60 ma. Perforated and printed tape may be prepared by use of the local circuits, and this tape may be used for transmission at the same time by using the transmitter distributor on a signal line. When the local circuits of the jack box are used, the d-c power cord of the jack box is connected to a source of 105-125 volts direct current.

b. SIGNAL CIRCUITS. The keyboard transmitting contacts of the reperforator are connected to a cord with a black shell plug, and the selector-magnet coils are connected to a cord with a red shell plug. The contacts of the transmitter distributor are connected to a cord with a gray shell plug. The jack box or connection box, mounted on the base of the rear of the reperforator, makes it possible to operate over one or two lines for which four closed-circuit jacks

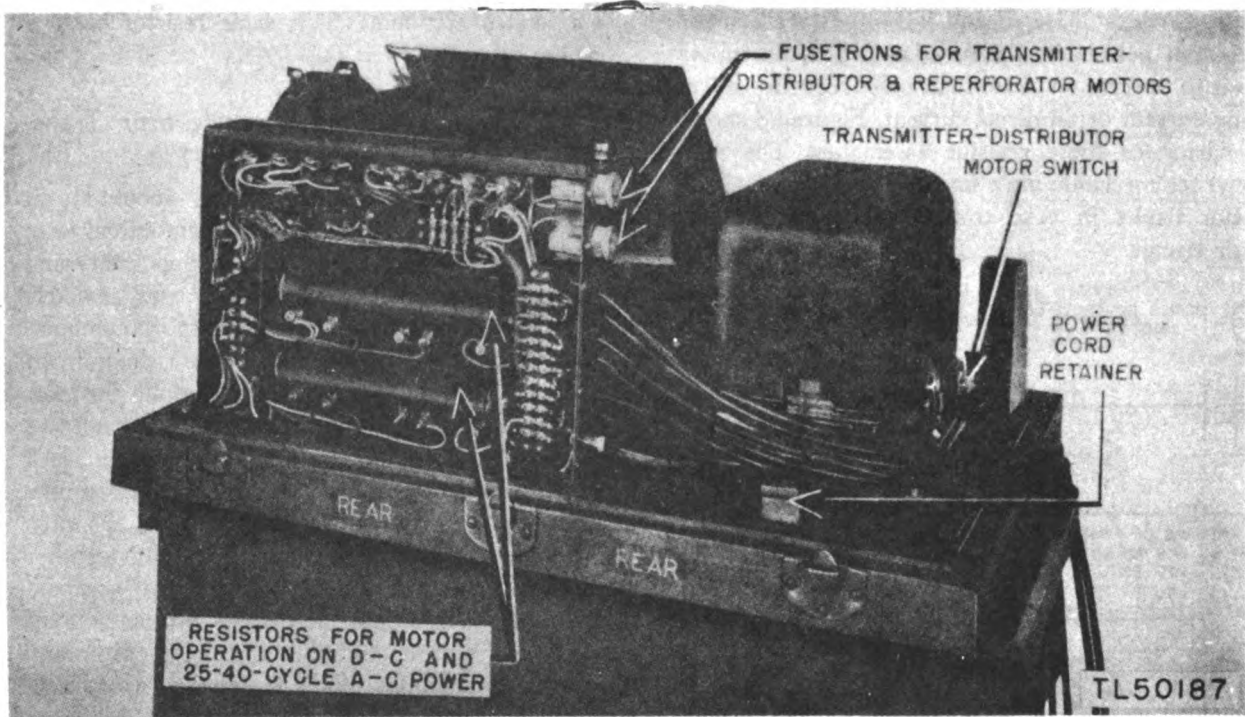

Figure 99. Connection (jack) box of Reperforator Transmitters TG-26-A and TG-27-A.

for each line are provided (two send and two receive). The jacks may be connected to line units by SEND and REC plugs. (See fig. 100.)

c. **SELECTOR SWITCHES.** The power-selector switches for the reperforator are mounted on the connection box. These switches are mechanically connected to provide simultaneous positioning. They operate in the same way as the resistor bank switch of Teletypewriter TG-7-B and permit the operation on 50-60-cycle and 25-40-cycle alternating current, and on direct current. Unlike Teletypewriter TG-7-B, the 25- and 40-cycle position is the same. These switches operate in conjunction with two resistors (fig. 99) mounted within the jack box. The resistor for the reperforator motor has taps for 25-40-cycle a-c operation (40 ohms), d-c operation (50 ohms), and 50-60-cycle a-c operation (15 ohms). The taps on the resistor for the transmitter distributor motor are set for the same types of operation but the respective resistance differs slightly. For 25-40-cycle alternating current, 40 ohms is inserted into the motor circuit; for d-c operation, 50 ohms is used; and when 50-60-cycle alternating current is used for the transmitter distributor motor, 20 ohms is inserted.

57. General Maintenance Procedures

Field servicing will generally consist of routine periodic inspection, lubrication, and adjustment of the equipment, changing relays, replacing fuses, tightening loose parts, and keeping the unit clean. Great care should be taken in handling field equipment, especially in packing and unpacking. This will greatly reduce the amount of maintenance work required by the various units. Maintenance of Rectifier RA-37 and RA-87 and test of bias meters are covered in another section. The line unit meter must be handled very carefully and disconnected from its terminal before tests are made within the unit. Spare fuses are carried in Chests CH-53 and CH-53-A. Before replacing a fuse, the cause of its blowing must be remedied. Fuses are located in the following places:

a. **TELETYPEWRITERS.** A 1.4-amp Edison base fuse is located in a socket at the rear of the base under the machine cover.

b. **LINE UNITS.** A ¼-amp, type 8AG, glass-enclosed fuse is located on the meter panel of Line Unit BE-77-A. This is the only fuse used in the line unit. With line voltage applied to the line terminals, a blown fuse is indicated by the chattering

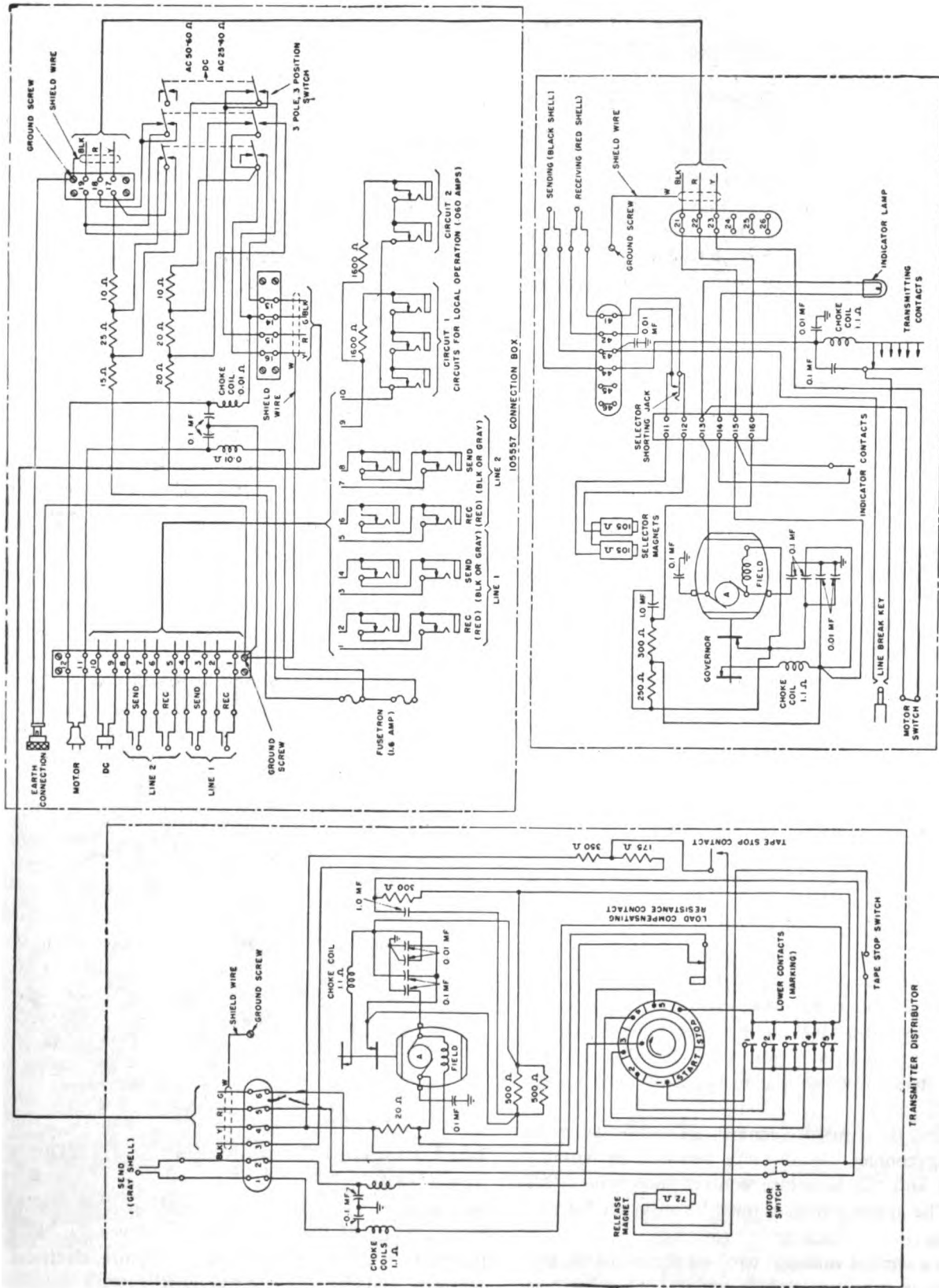

TL 985418

SENDING-RECEIVING TYPING REPERFORATOR

Figure 100. Reperforator Transmitter Sets TG-26-A and TG-27-A, schematic wiring diagram.

of the neon lamp blown-fuse indicator. If this lamp glows, replace the fuse with a spare carried in Chest CH-53-A. The 5-amp fuse for the rectifier is also carried in the chest; be careful not to mistake it for the $\frac{1}{4}$ -amp line unit fuse.

c. REPERFORATOR TRANSMITTERS. In reperforator transmitters, two 1.6-amp Edison base fusetrans are located in sockets at the upper left-hand side of the jack box and are protected by a hinged cover. The upper fusetrans is in the transmitter distributor motor circuit; the lower one protects the motor of the reperforator.

d. RECTIFIER RA-37. A 5-amp, type 3AG, glass-enclosed fuse is located on the tap-changing panel of Rectifier RA-37.

e. RECTIFIER RA-87. A 5-amp, type 3AG, glass-enclosed fuse is mounted on the tap-changing panel of Rectifier RA-87 for the d-c circuits. A 15-amp, fiber-enclosed cartridge fuse is located beneath the chassis for the a-c circuits.

f. POWER UNIT PE-77. The power unit has no fuse.

58. 41-type Relay

The relay can be removed by pulling it out of the line unit through the door in the front of the line unit housing. It may be replaced with any other 41-A, 41-B, or 41-C relay in good condition. Ordinarily the relay should require no other attention than adjustment of the spring tension when circuits are being lined up. At times, however, the following adjustments may be necessary.

a. Maintain the fixed air gap between the bearing end of the armature and the corresponding core face at 0.008 inch. The gap can be adjusted by loosening the screws which hold the core in place and shifting the core.

b. With the armature contact held against the marking contact, the working air gap between the free end of the armature and the corresponding core face should be 0.006 inch. This air gap can be secured by adjusting the marking contact with a multiple spline wrench for No. 5 fluted-socket set-screws, two of which are included in Tool Equipment TE-50.

c. With the armature contact still held against the marking contact, the distance between the spacing contact and the armature contact should be 0.003 inch. The spacing contact must be adjusted for this distance.

d. The contact material used on the armature and contacts is tungsten carbide and is not subject to

pits and build-ups. Do not attempt to use a file or contact burnisher on the contacts as tungsten carbide is an exceptionally hard metal and will cut chips from the file or burnisher. These may short-circuit the contacts. If it is necessary to dress the contacts, remove the relay and grind them on a fine carborundum stone.

59. Interoperation of American and British Field Equipment

In the field, the teletypewriter mechanic may be required to install American teletypewriter equipment to operate in conjunction with British teleprinter equipment. For this reason, it is necessary for him to be familiar with the British equipment and the modifications that must be made to permit interoperation of the two types. The basic difference between American and British equipment is that the American equipment normally operates on a neutral basis and the British equipment operates, normally, on a polar basis. Figure 101 shows a British field teleprinter with batteries and Mark IV terminal unit. The terminal unit corresponds somewhat to the American line unit.

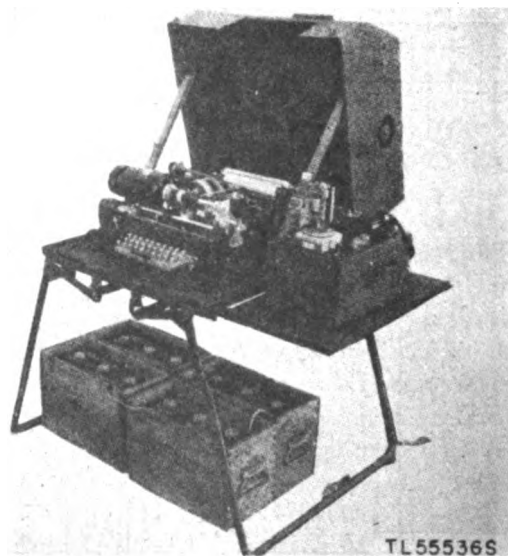

Figure 101. British teleprinter with batteries and terminal unit Mark IV.

60. Features of British Teleprinter 7B(WD)

The British Teleprinter 7B(WD) (fig. 102) can be compared to the American Teletypewriter TG-7-B in method of communication. It serves the same purpose but differs in mechanical structure, electrical features, and operating characteristics.

a. **SELECTOR CODES.** Teleprinter 7B(WD) uses the same type five-unit start-stop code as American teletypewriter equipment; however, impulses transmitted differ in length. The starting impulse and the five selecting impulses transmitted by the British teleprinter equipment are each 20 milliseconds long, and the stop impulse is 30 milliseconds long; corresponding impulses transmitted by American teletypewriter equipment at normal speed (368 operations per minute (opm)) are 22 and 31 milliseconds, respectively. The impulses transmitted by the teleprinter are shorter than those transmitted by the teletypewriter because the British equipment operates at higher speed. Since teletypewriter impulses are longer than teleprinter impulses, it is necessary to increase the speed of the American equipment to 404 opm when it is to operate with British equipment. Figure 103 graphically illustrates the length of the impulses of the letter R as transmitted from a teletypewriter at normal speed, the same letter transmitted by the British teleprinter, and the letter transmitted by a teletypewriter at modified speed. When the teletypewriter is operating at 404 opm, the impulses transmitted by the American and British printing units are identical, with the exception of the stop impulses. The slight difference in length of the stop impulses will not impair operation, but because of the increase in speed, the range of the teletypewriter will be reduced.

b. **KEYBOARD TRANSMITTER.** The keyboard transmitter of Teleprinter 7B(WD) is equipped with

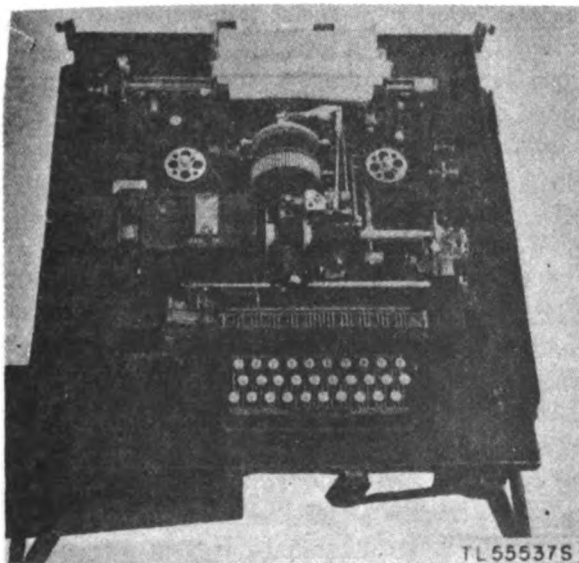

Figure 102. Teleprinter 7B(WD).

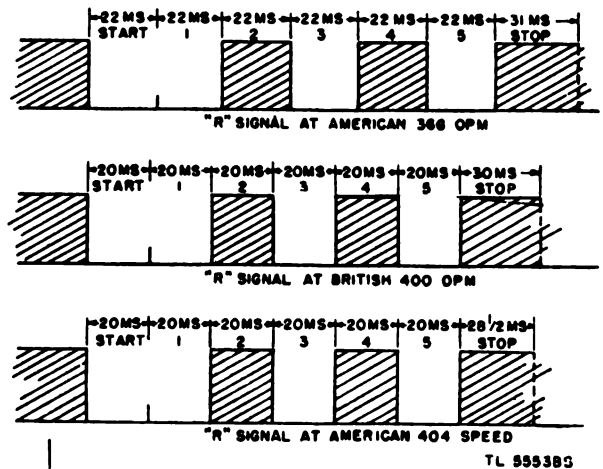

Figure 103. Length of impulses of letter R at American and British speeds.

30 keys, a space bar, polar transmitting contacts, and an automatic SEND-RECEIVE switch. It does not have a blank key or space repeat device. Its lower case characters are identical to those on the keyboard of Teletypewriter TG-7-B, but its upper case characters differ. The difference in the upper case characters of the two keyboards is illustrated in figure 104. Instead of six transmitting contacts to transmit the start, five selecting, and stop impulses, Teleprinter 7B(WD) uses a single mechanically operated transmitting lever, working between two adjustable contacts (marking and spacing). This transmitter is designed to send polar signals, whereas the American transmitter sends neutral signals. The British transmitter can be converted to send neutral signals simply by removing battery from the

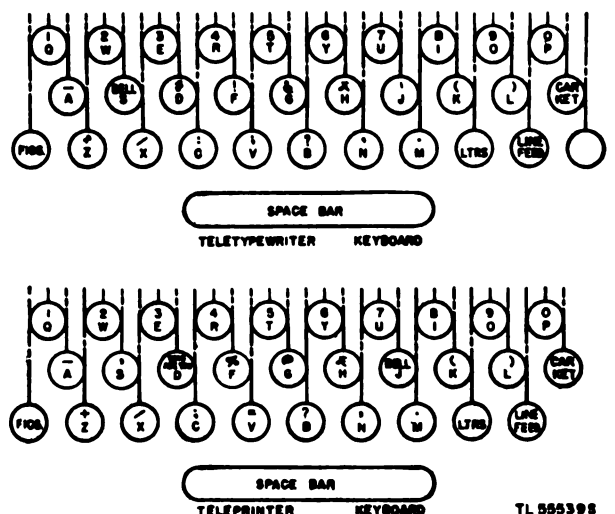

Figure 104. Comparison of American and British keyboard characters.

space transmitter contact. The automatic SEND-RECEIVE switch is used to change the line circuit from send to receive or vice versa when the teleprinter is on polar operation. When all keyboard keys are normal, the switch is in the receive position; and when any key is depressed, the switch operates to the send position and automatically returns to receive after the character is transmitted.

c. RECEIVING MECHANISM. The teleprinter receiving mechanism is controlled by a polar selector magnet which receives polar impulses from the transmitter and mechanically distributes them. The character is stored after it is mechanically set up, until another character is transmitted; then the character stored is printed. In other words, the British teleprinter is arranged to be one operation behind in printing any character or operating any function. The polar selector magnet of this receiving mechanism may be converted to a neutral selector magnet by the application of a biasing spring to pull the armature to the spacing position when a spacing impulse is received.

d. PRINTING APPARATUS. Teleprinter 7B(WD) does not have a type bar carriage such as is on Teletypewriter TG-7-B, but instead has a laterally stationary assembly called a type head which contains type bars. This type head is rotated according to the group of impulses received and brings the desired type bar into printing position. The platen assembly of the teleprinter spaces with each character printed and returns when the carriage-return key is depressed. The maximum length of the typed line is limited to 70 characters by the constructional characteristics of the printing unit. A symbol-counting attachment may be fitted to the teleprinter to count characters transmitted when the teleprinter is operated full-duplex.

e. SPEED. British equipment normally transmits individual characters at a rate of 400 characters or operations a minute, but the mechanical inertia of the keyboard makes it impossible to maintain this speed when transmitting consecutive characters. A good operator can send at a rate equivalent to approximately 360 opm or 60 words per minute.

f. MOTOR AND MOTOR CONTROL. Teleprinter 7B(WD) is driven by a d-c governed shunt motor which requires a 24-volt, 3-amp d-c power supply for its operation. The motor governor is factory-adjusted to maintain the motor speed at 3,000 rpm. A stroboscope is used in conjunction with a target on the end of a shaft at the front of the printer to check the motor speed. The stroboscope may be

compared to the tuning fork in function. For motor control (start or stop motor), the teleprinter is equipped with an automatic switch in the motor circuit which will switch the printer on when a message is being received, and switch it off when the printer is idle for 1½ minutes.

g. ANSWER-BACK UNIT. An answer-back unit is fitted on the teleprinter. This automatically transmits code groups corresponding to the station's name when the upper case D (Who are you?) is received. If a transmitting station wishes to verify that the station to whom he is sending is switched on and working properly, he depresses the *Who are you?* key. The receiving station's answer-back unit will operate and send the station's code name back to the transmitting station. The operator at the transmitting station can then carry on with his message, knowing that it is being correctly received at the distant station. Use of this unit also verifies that the correct station has been obtained when working through a switchboard. This feature of the teleprinter is used in Defense Teleprinter Network in Great Britain. Although the unit is incorporated in the teleprinter, it is not used in the field.

h. SIGNAL BELL. Teleprinters do not contain a signal bell, but an attachment can be added so that when the upper case of J is received, an external signal bell will sound.

61. Circuits of Teleprinter 7B(WD)

The wiring diagrams (figs. 105 and 106) are schematic circuit drawings of the electrical equipment and wiring of Teleprinter 7B(WD). The teleprinter selector magnets, transmitting contacts, and SEND-RECEIVE switch wiring are terminated in two terminal blocks (A and B) to which is attached a nine-conductor cord with line plug. (See fig. 105.) This line plug and cord is provided to connect the teleprinter signaling apparatus to the Mark IV terminal unit. The alarm contacts are used to operate an external signal bell when it is wired to the printer. The motor, governor, motor control contacts, and filter (fig. 106) terminate at two terminal blocks (C and motor terminal block) to which is attached a three-conductor power cord and plug. The power cord and plug is provided to connect the printer motor apparatus to this three-point receptacle on the terminal unit. All circuits are wired with filter units to prevent sparking and radio interference.

a. SEND-RECEIVE CIRCUIT. The send-receive circuit (fig. 105) is used to connect and disconnect

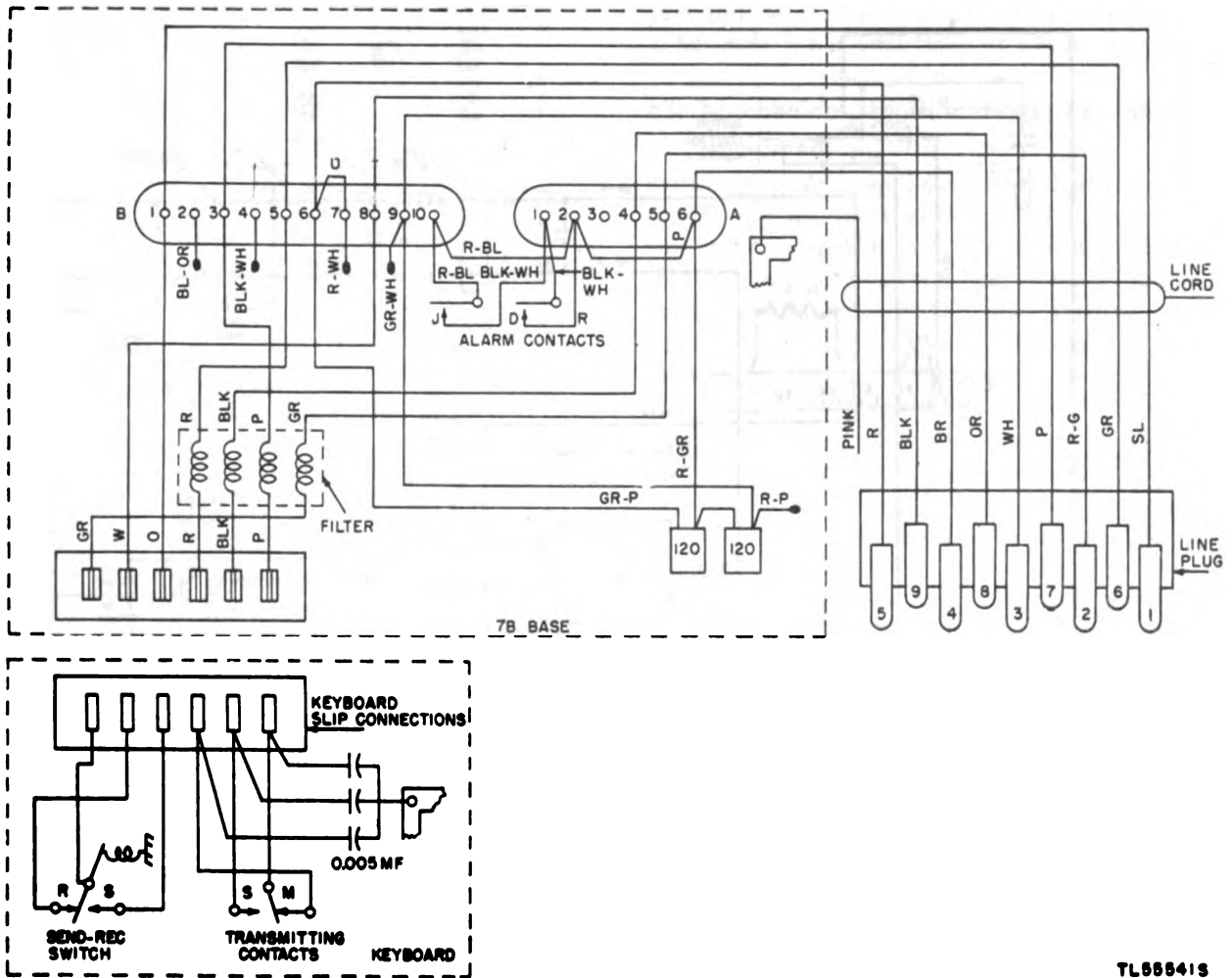

TL55541S

Figure 105. Teleprinter 7B(WD) arranged for use with terminal unit Mark IV.

transmitting battery for polar operation. The receive side of the circuit can be traced from line plug terminal No. 2 to No. 5 on terminal block A, through the filter, armature of the send-receive apparatus, R (receive) contact, to No. 8 of terminal block B; and back to line plug terminal No. 9. The send side of the circuit goes from the armature of the send-receive apparatus to the S (send) contact, to No. 1 of the B block, and to the line plug terminal No. 1.

b. **SELECTOR MAGNET CIRCUIT.** The selector magnet circuit of the teleprinter performs the same function as the magnet circuit of a teletypewriter. It traces from line plug terminal No. 3 to terminal No. 9 of the B block through the selector magnets and terminal No. 6 of the B block, to line plug terminal No. 5. There is also a tap off the juncture of the two magnet windings to terminal No. 6 of block A and to line plug terminal No. 4. This tap

is used when the teleprinter is wired for neutral operation and only one magnet is required.

c. **MOTOR CIRCUITS.** The motors used in field teleprinters are 24-volt d-c shunt motors and operate from storage batteries. Figure 106 is the motor circuit diagram. The armature circuit goes from power plug terminal N to A on the motor terminal block, through the armature to AA on the motor terminal block, through No. 2 of the C block, through the motor control contact, and back to power plug terminal L. The field winding may be traced from power plug terminal N to No. 6 of the C block, then either through the governor contacts or the 50-ohm resistor to No. 3 of the C block (depending upon whether the governor contacts are open or closed). From terminal 3 it may be followed to AZ on the motor terminal block, through the field to ZZ of the motor terminal block, then to No. 2 of

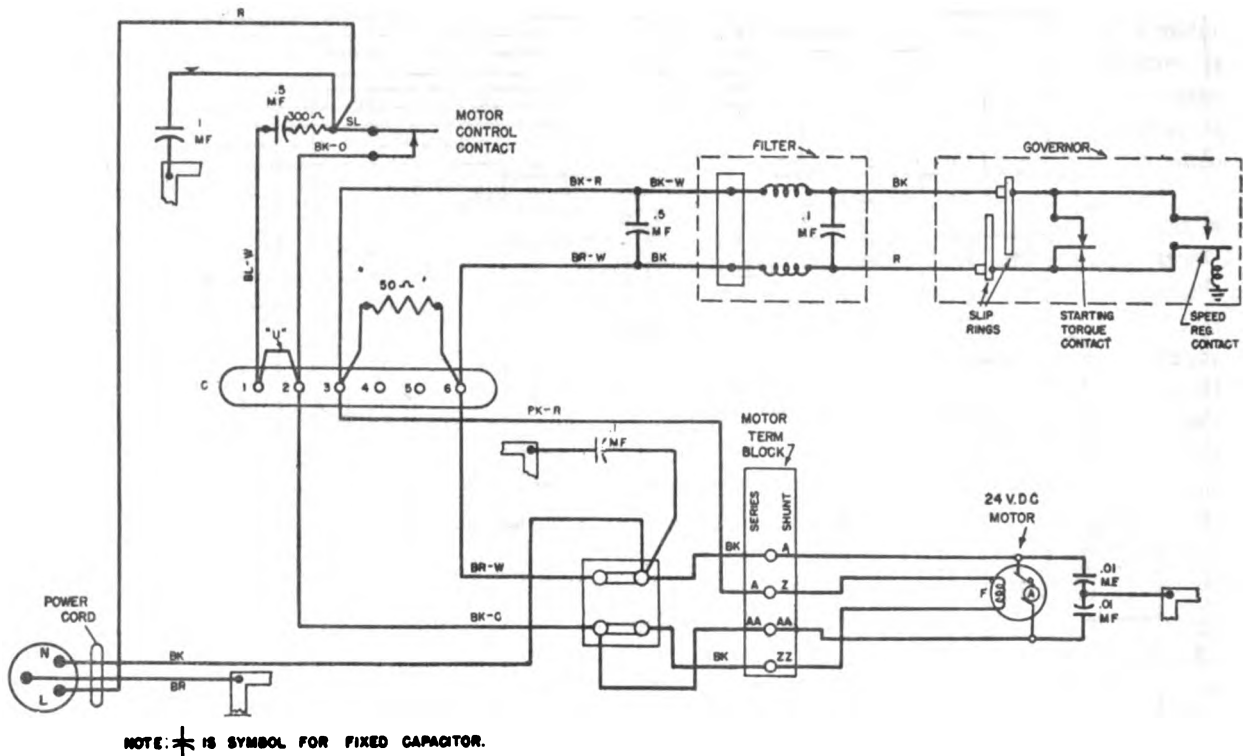

TL555428

Figure 106. Teleprinter motor circuit.

the C block, to the motor control contacts, and back to power plug terminal L.

62. Teleprinter Terminal Unit Mark IV

To facilitate establishing connections between printer lines, ground, and battery, and arranging various circuits with their meters, relays, current-adjusting potentiometers, etc., teleprinter terminal units have been designed. Terminal unit Mark IV (fig. 107) makes use of a polar relay to receive line signals and repeat them to the printer selector magnet. It has meter connections and rheostats for making current adjustments and measurements, and a key which permits sending steady marking or spacing signals for adjusting and signaling. Terminals are provided for the connection of a 24-volt center-tapped battery, and line and earth connections. Three plug sockets are located on the top of the terminal unit. Two of these sockets receive three-pronged plugs from the teleprinter motor and symbol-counting attachment. The third socket receives the nine-pronged plug on the cord from the printer transmitter, selector magnet, and SEND-RECEIVE switch. Terminals are also included on

the unit whereby additional signaling voltage can be added to the marking and spacing batteries without altering the 24-volt supply to the motor. The U link field and line terminals of the unit facilitate adjustment to adapt it for various circuit operations.

a. RELAY 299-AN. The relay used on the terminal unit Mark IV is a general purpose polarized relay, similar to the 215 type. It contains soft iron adjustable pole pieces, a permanent magnet, a soft iron armature, a pair of contact screws, and a coil containing six windings terminating in a 16-point jack base. The six windings of the relay are connected to the jack base as shown in figure 108. Its four operating coils are identical, and the two auxiliary windings are identical. The relay itself is very sensitive and will operate satisfactorily on 2 ma direct current, but the normal operating current is 4 to 20 ma, depending on the number of coils used. Each of the four operate windings of the relay has 160 ohms resistance, and each of the two auxiliary windings has 115 ohms resistance. Usually the four operate windings are connected in series in the line circuit. The two auxiliary windings are sometimes used for biasing purposes. However,

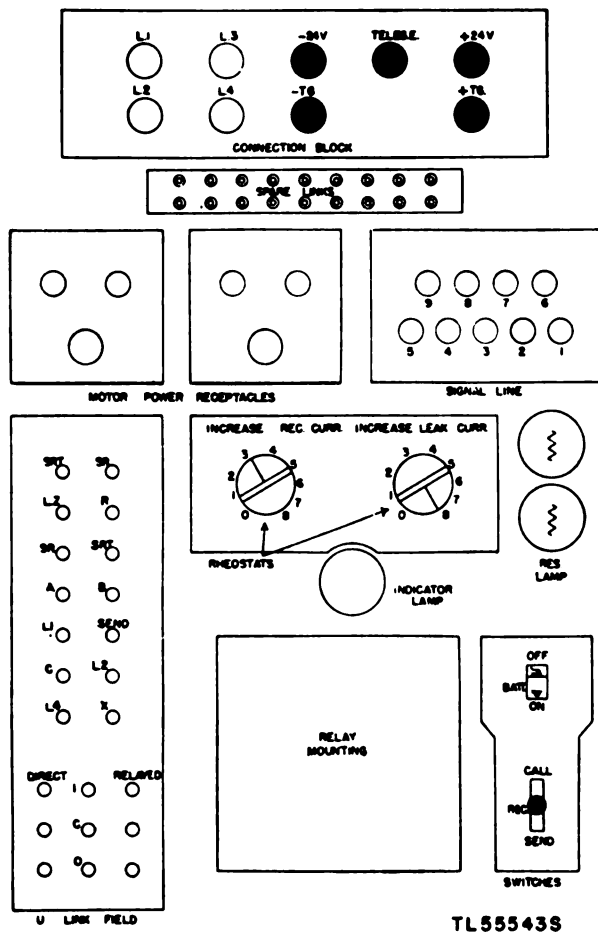

Figure 107. Terminal unit Mark IV.

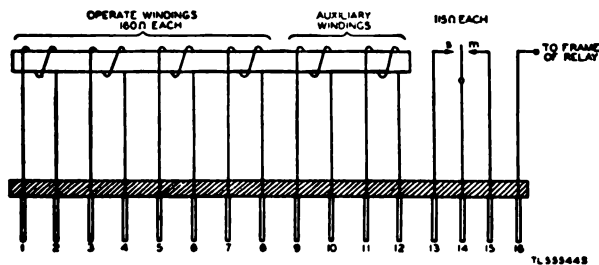

Figure 108. Connections of a 299-AN relay.

when the terminal unit is to operate with the relay on a neutral circuit, only the two auxiliary windings are used. In this case, the 9-10 winding is used as the line winding and the 11-12 winding is used as the bias winding.

b. CIRCUITS. The teleprinter may be arranged for various types of circuit operation through the use of the U link field of the terminal unit. Figure 109 is a schematic diagram of the Mark IV terminal

unit, and the table attached indicates the connections to be made for several types of circuit operation.

63. Mechanical Modifications of American Equipment

British teleprinter equipment is designed to operate at 400 opm on polar circuits, and American teletypewriter equipment is designed to operate at 368 opm on neutral circuits. The two also differ in some mechanical characteristics; therefore, it is necessary to modify either one or both sets before connections for interoperation can be made.

a. SPEED CORRECTION. Since the British teleprinter operates at 400 opm, it is necessary to adjust the speed of the American teletypewriters from 368 to 404 opm. The speed is changed on the American equipment rather than the British equipment because it is easier to adjust. To facilitate adjustment of the teletypewriter to 404 opm, a special tuning fork (Signal Corps stock No. 104984) is used. This tuning fork can be distinguished from the standard tuning fork by the markings on its handle. It has *British Speed—404 opm* clearly marked on the handle and is calibrated for 96.19 vibrations per second; the standard tuning fork is calibrated for 87.6 vibrations per second. The special tuning fork is used in conjunction with the regular 10-spot target of the series-governed motor; follow the same procedure in adjusting the motor speed to 404 opm as is used to adjust it to 368 opm. Care must be exercised in adjusting the motor to avoid setting it at a multiple speed.

b. UNSHIFT-ON-SPACE FEATURE. The British teleprinter does not contain an unshift-on-space feature; therefore, this feature must be made inoperative on American equipment before it is connected to the British equipment.

c. LENGTH OF TYPED LINE. American printers are normally adjusted to print 72 characters per line, while British machines print only 70 characters per line. This difference may result in overprinting, so it must be remedied by adjusting the right-hand margin of the American printer for 70 characters per line. The margin signal bell is adjusted to operate on the 64th character printed. A corresponding adjustment is made for the end-of-line indicator of perforators and typing reperforators which will be used with the modified machines.

d. SELECTOR ARMATURE SPRING ADJUSTMENT. When the operating speed of the teletypewriter equipment (368 opm) is increased to operate with the British equipment (404 opm), the tension of

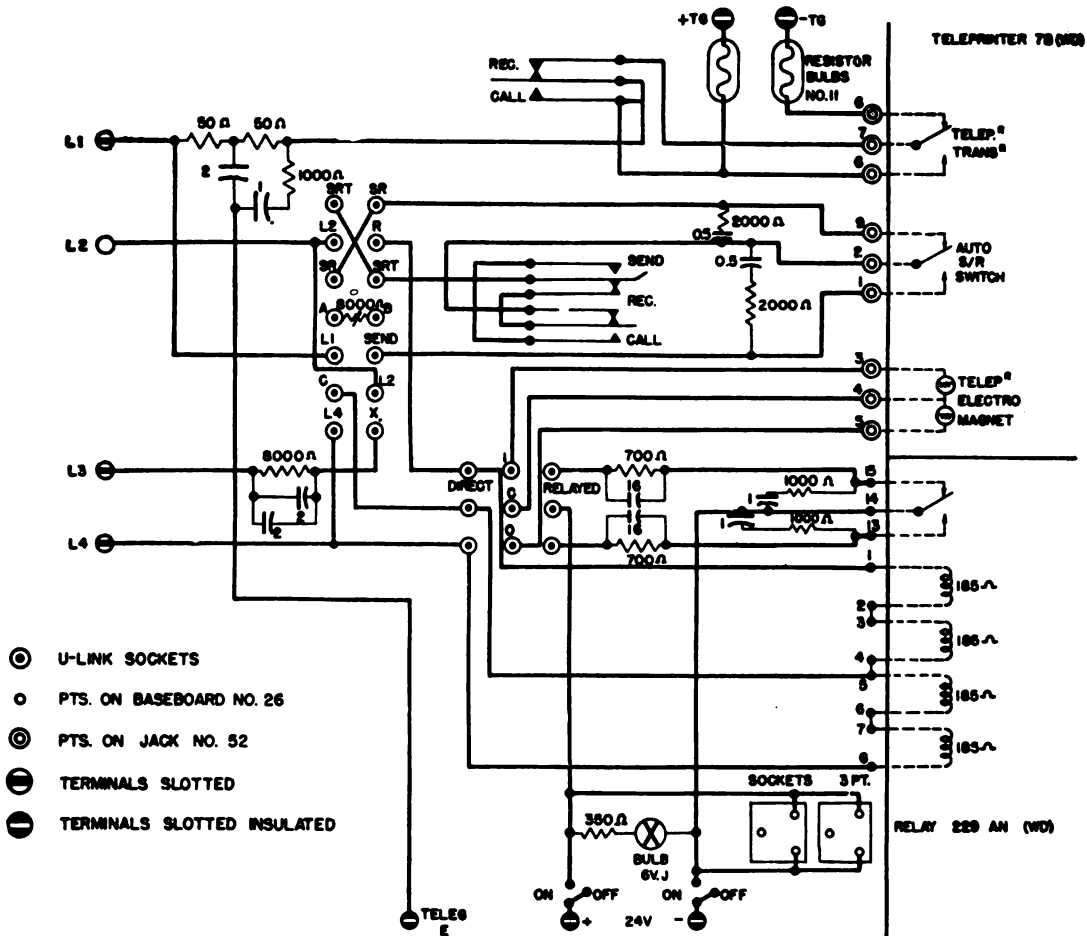

INSTRUCTIONS FOR SETTING UP

1. INSERT U-LINKS. CONNECT LINES AND STRAP TELEGE AS SHOWN ON ADJOINING TABLE ACCORDING TO FACILITY REQUIRED.
2. INSERT 3 U-LINKS INTO DIRECT OR RELAYED POSITIONS AS REQUIRED (ARELAY 229 AN IS CARRIED IN REAR COMPARTMENT OF BOX, AND SHOULD BE PLUGGED INTO FRONT JACK FOR USE).
3. SCREW RESISTOR BULB NO.11 INTO SOCKETS ON FRONT PANEL.
4. CONNECT +24V. AND -24V. TERMINALS TO 24VOLT 3-AMP D.C. SUPPLY (E.G. 100/125 A.H. BATTERY).
5. CONNECT +TG. -TG. AND TELEGE TO +24V. -24V. AND CENTER TAP OF 24V. SUPPLY RESPECTIVELY. ALTERNATIVELY, WHERE TELEGRAPH VOLTAGE GREATER THAN 12+12 IS REQUIRED, CONNECT +TG.-TG. TELEGE TO SUITABLE CENTRE TAPPED SUPPLY.
6. INSERT 9-POINT AND 3-POINT PLUGS OF TELEPRINTER 7B(WD) AND 3-POINT PLUGS OF SYMBOL COUNTING ATTACHMENT IF WORKING WITHOUT LOCAL RECORD, INTO SOCKET PROVIDED.
7. TO ADJUST RECEIVE CURRENT:-RECEIVE MARK FROM DISTANT END AND MEASURE CURRENT AT U-LINK SOCKETS INDICATED IN TABLE BY MEANS OF CONNECTORS PROVIDED AND A TEST SET PORTABLE NO.2 MK. I. ADJUST RECEIVE RESISTANCE TO GIVE NOT MORE THAN 10 MA. FOR RELAYED OR 30 MA. FOR DIRECT OPERATION.
8. TO ADJUST LEAK CURRENT:- (FOR LOCAL RECORD ONLY) THROW SEND-REC. KEY TO SEND THUS SENDING MARK ADJUST LEAK RESISTANCE AS IN 7 ABOVE. RESTORE "SEND-REC" KEY TO NORMAL.
9. THROW ON-OFF SWITCH TO ON, THUS STARTING MOTOR.
10. CHECK TELEPRINTER OPERATION IN BOTH DIRECTIONS.

NOTE - FOR FULL-DUPLEX THE RECEIVE RESISTANCE MUST BE ADJUSTED UNTIL NO LOCAL RECORD IS REGISTERED WHEN SENDING.

NOTE: * IS SYMBOL FOR FIXED CAPACITOR.

FACILITIES	SWITCHED		TWO-LINE SIMPLEX			HALF DUPLEX
	SIMPLEX		WITH LOCAL RECORD		WITHOUT RECORD	
U-LINK	SRT L2	SR R				
POSNS	SR A	SRT B				
THICK LINES INDICATE	L1	SEND				
TEST POSNS	C	L2				
	L4	X				
LINE TERMINALS USED	L2 L3	(S) (R) L1 L3	L4	(S) (R) L1 L3 L4		L2 L3
TELEGE STRAP TO:-	L3	L4	L4	L4		L3
MEASURE REC.-LEAK CURRENT AT:-	L4-X	R-SRT		R-L2		R-L2 (LINE) L4-X (BAL)

TL555458

Figure 109. Circuits of teleprinter terminal unit Mark IV.

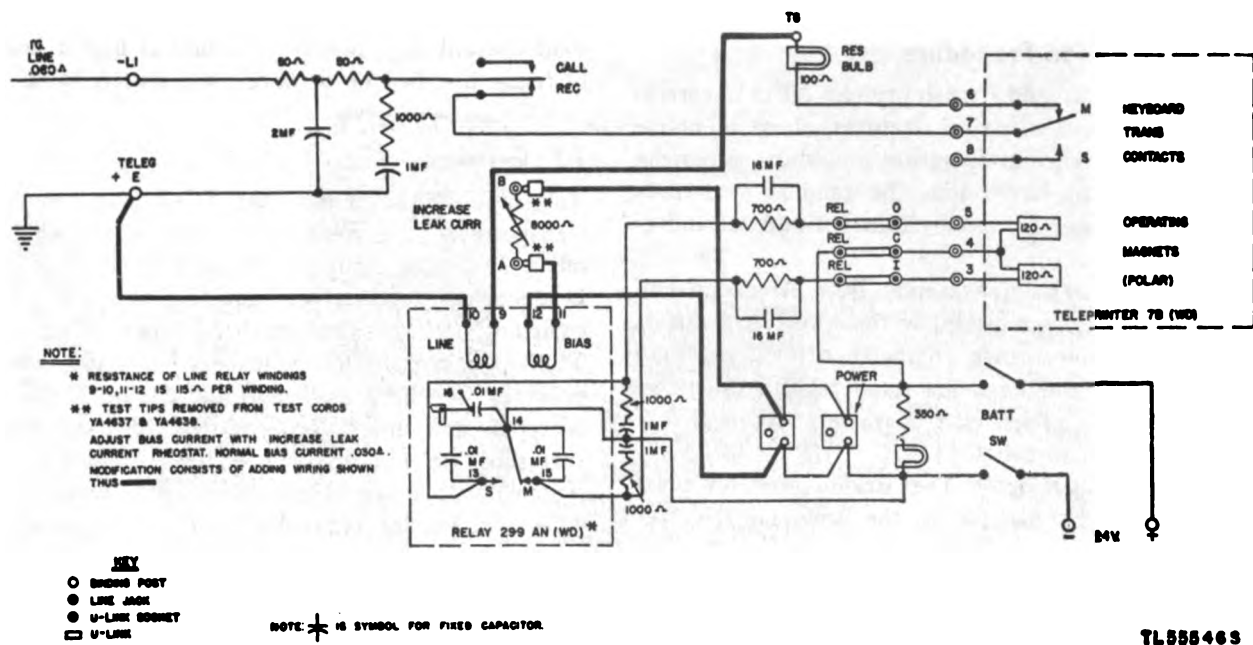

Figure 110. Neutral operation—line relay.

TL555463

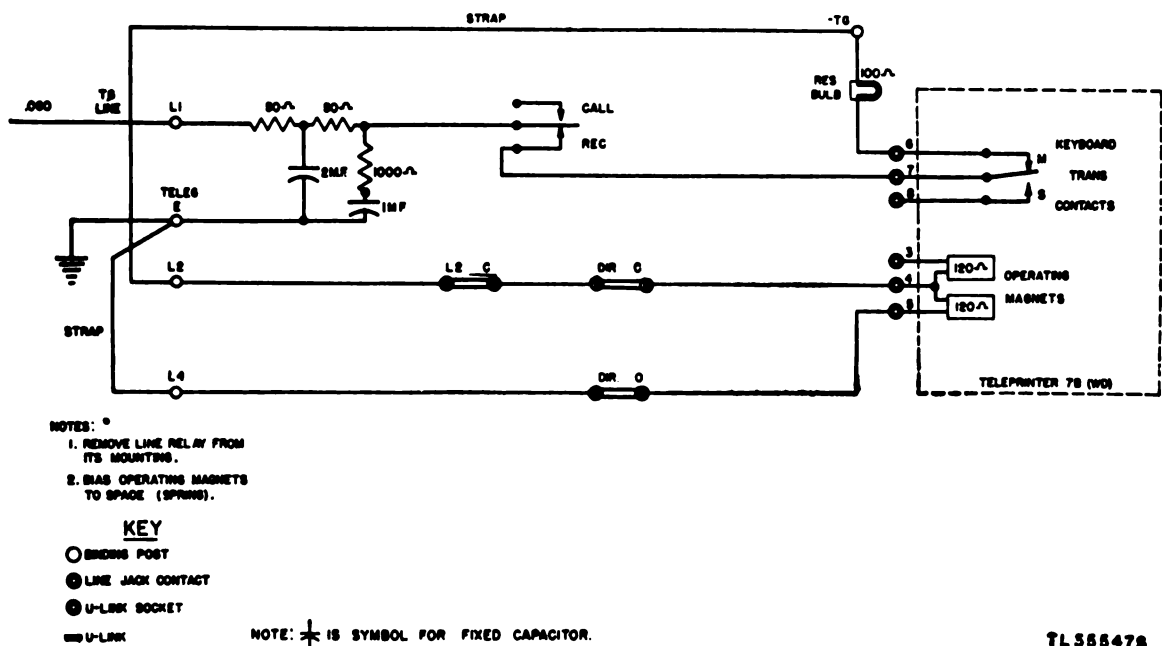

Figure 111. Neutral operation—direct magnet.

TL555478

the armature spring on the teletypewriter receiving mechanism should be increased by approximately 1/2 ounce.

64. Modifications of Terminal Unit Mark IV

Since the British equipment is normally operated with polar signals, the terminal unit is arranged to provide various types of polar circuit operation. When the British equipment is to interoperate with

American equipment, it is necessary to make some wiring modifications on the terminal unit so that its line relay will function on neutral signals. Figure 110 shows the wiring changes necessary on the terminal unit for relay operation with U.S. Army teletypewriters or Switchboard BD-100. Figure 111 shows the wiring changes necessary for direct magnet operation with United States Army teletypewriters or Switchboard BD-100.

65. Operation Procedure

Since American and British printers differ in certain mechanical and electrical features, there is necessarily a difference in operating procedure. American and British operators must be familiar with both types of printer to avoid confusion and misunderstandings.

a. **CHARACTER DIFFERENCE.** Both American and British operators must know their keyboard differences. The lower case character of both printers are identical and have the same relative positions. However, the upper case characters differ greatly as shown in figure 104.

b. **SIGNALING BELL.** The British operator must know that the signal bell of the American teletypewriter is rung by operating the upper case S. The American operator must remember that the British teleprinter does not have an internal signal bell and is not likely to have an external signal bell.

c. **MOTOR CONTROL.** The American operator cannot stop the motors of teleprinters by operating the upper case H but will only stop his own printer and any other American printers in the circuit that are equipped with mechanical motor stops. The British operator can stop teletypewriters in the circuit by operating the upper case H, but he cannot thereby shut off his own motor. The teleprinter motor is turned off automatically by its timing device.

d. **CHARACTER STORED IN BRITISH PRINTER.** British printers do not print each character or perform the function selected until a succeeding character or function is selected. American operators therefore should adhere to sending Letters, Carriage Return, and Line Feed at the end of each message. This causes the line-feed function to be stored on the British machine. Ending a message in this manner insures printing the last character of the message transmitted.

Section III. TELEGRAPH CENTRAL OFFICE EQUIPMENT

66. Introduction

Central office teletypewriter equipment may be installed on a permanent or semipermanent basis or may be used at an installation where it must be rapidly installed, removed, transported, and reinstalled. Telegraph Central Office Set TC-3 covered in the succeeding several paragraphs is designed for

field use although it may be found at higher headquarters installed on a more fixed-station basis.

67. General

Telegraph Central Office Set TC-3 is a complete transportable teletypewriter exchange or central office. It can be easily and quickly installed in any headquarters or location requiring the use of a switching central. Telegraph Central Office Set TC-3 is comprised of Switchboard BD-100, which provides switching and repeating facilities for 10 teletypewriter lines; Rectifier RA-43-(*), which furnishes the 115 volts of direct current for the switchboard; Power Unit PE-75-(*), which provides a source of 115 volts of 60-cycle alternating current for the rectifier and the operator's teletypewriter motor; Teletypewriter TG-7-(*), (operator's teletypewriter), for answering and supervising calls through the switchboard; two chests, Chest CH-53-A and Chest CH-70, for packing and transporting accessories, tools, and running spare parts for establishing earth connections for the switchboard. The chests and cases which go with the individual components are used to house and protect the equipment during transportation. They also serve as tables for the equipment and as seats for the operators. Figure 112 shows the complete telegraph central office set.

68. Switchboard BD-100

Switchboard BD-100 is a portable teletypewriter switchboard designed for field use and is composed of two principal parts: An angle framework and the switchboard cabinet. (See fig. 113.) The angle iron framework is used as a carrying case and supporting member for the switchboard cabinet. Switchboard BD-100 provides switching and full repeating facilities for a maximum of 10 lines which may be either ground return or metallic. Line current may be supplied by the switchboard or the distant station or both. The front of the switchboard is divided into five panels arranged one above the other. (See fig. 114.) The back of the switchboard has a hinged gate on which are mounted 10 pairs of neutral relays. Both front and back are protected by steel covers during transportation.

a. **LINE RHEOSTAT AND METER PANEL.** The line rheostat and meter panel mounts 10 rheostats and a meter. Each rheostat controls the line current in its respective line connected to the board. By using a key mounted on the patching panel, the meter

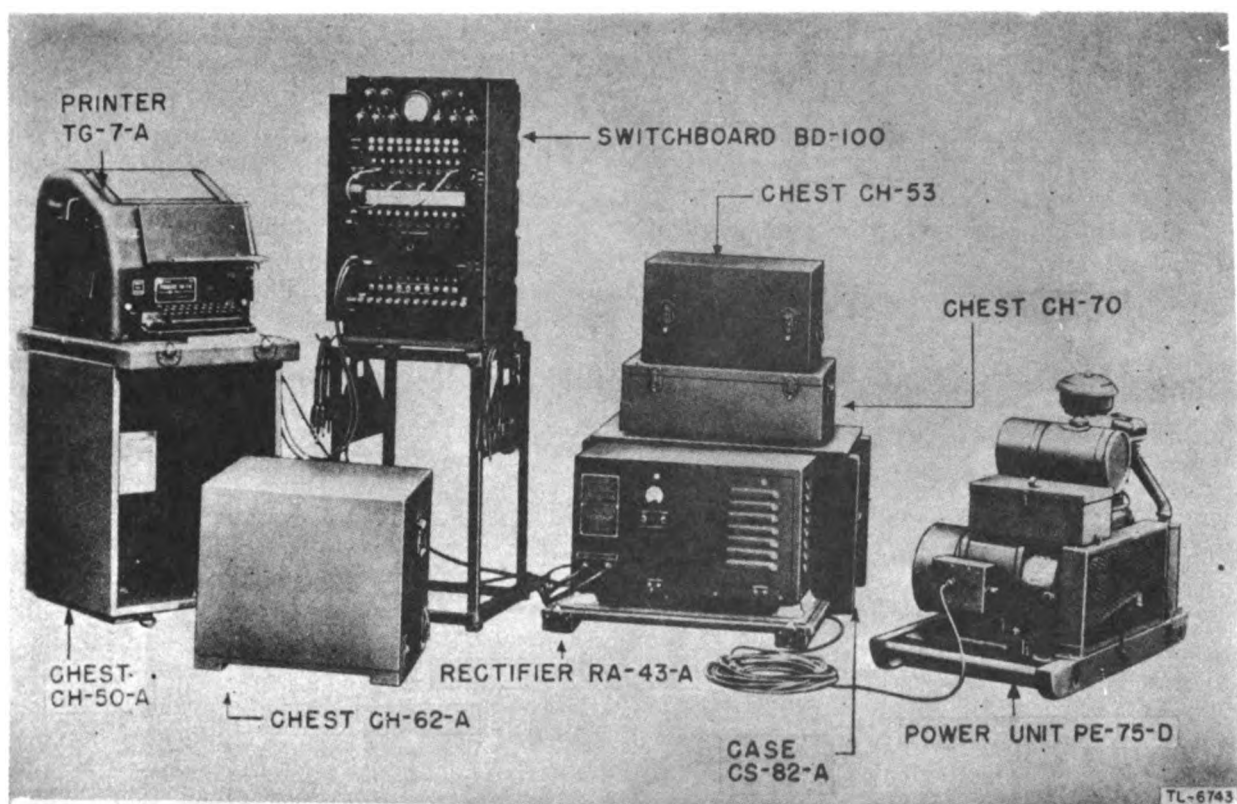

Figure 112. Telegraph Central Office Set TC-3.

can be used either as a voltmeter, a milliammeter, or a bias meter.

b. MONITORING PANEL. The LINE OPEN and ANSWER buttons are mounted on the monitoring panel. The LINE OPEN (white) buttons are used to extinguish the signal lamps on open lines and are released by the corresponding ANSWER button. The ANSWER (blue) buttons are used to put the operator's teletypewriter into any one of the signal line circuits connected to the board. They are interconnected and will release one another, thereby preventing the operator's teletypewriter from being connected to more than one line at a time. The release button releases all the answer buttons.

c. PATCHING JACK PANELS. On the patching jack panel are mounted 10 signal lamps, two rows of jacks, a NIGHT ALARM key, the METER switching key, and a strip on which to mark station names. The signal lamps are provided to signal the operator. Both rows of jacks are for switching facilities; the lower jacks are also used to measure line bias. The NIGHT ALARM is located on the left side of the patching jack panel. When the night alarm is at ON, a buzzer sounds when the

signal lamp lights. When it is at OFF, the buzzer does not operate, but the signal lamp lights.

d. METER CONTROL PANEL. A row of 10 red LINE CURRENT buttons, a release (REL) button (black), a BIAS METER jack, and 10 jacks for measuring local bias are mounted on the meter control panel.

e. LINE SWITCH AND FUSE PANEL. Mounted on the line switch and fuse panel are the operator's teletypewriter jacks, the MULTIPLE jacks, 10 toggle switches, 12 blown-fuse indicator (neon) lamps, and 12 fuses. There is a fuse and blown-fuse indicator for the operator's teletypewriter circuit, for each line circuit, and for the meter circuit. When the toggle switches are in the upper position, current is supplied to the line from the switchboard; in the lower position, current is being supplied by the distant station. The multiple jacks are used to connect two boards in multiple. The operator's teletypewriter jacks provide a way of connecting the operator's teletypewriter to the switchboard. The 12 neon lamps indicate when fuses are blown.

f. TERMINAL STRIP. On the left side of the switchboard is a terminal strip (fig. 115) with 12

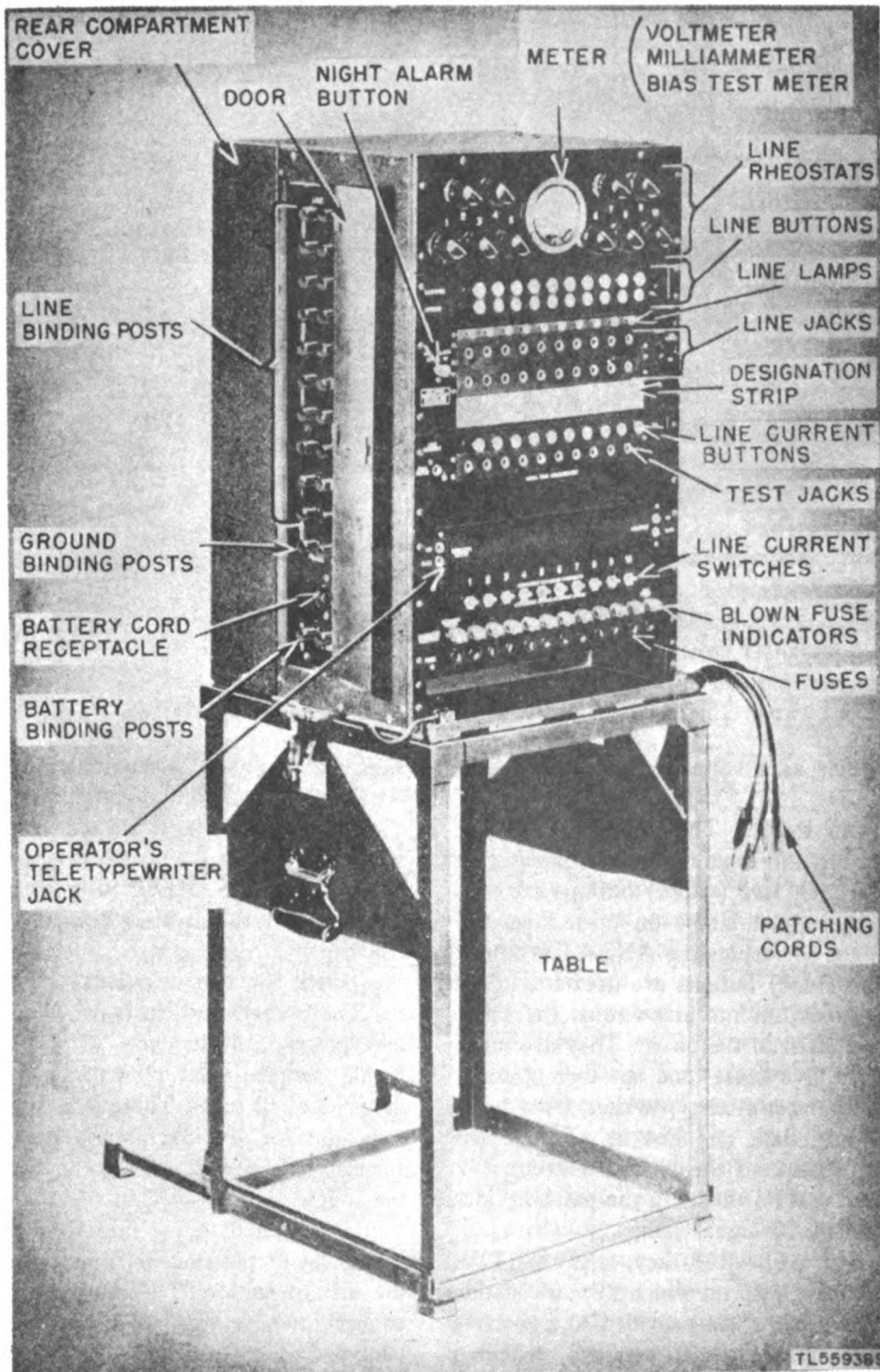
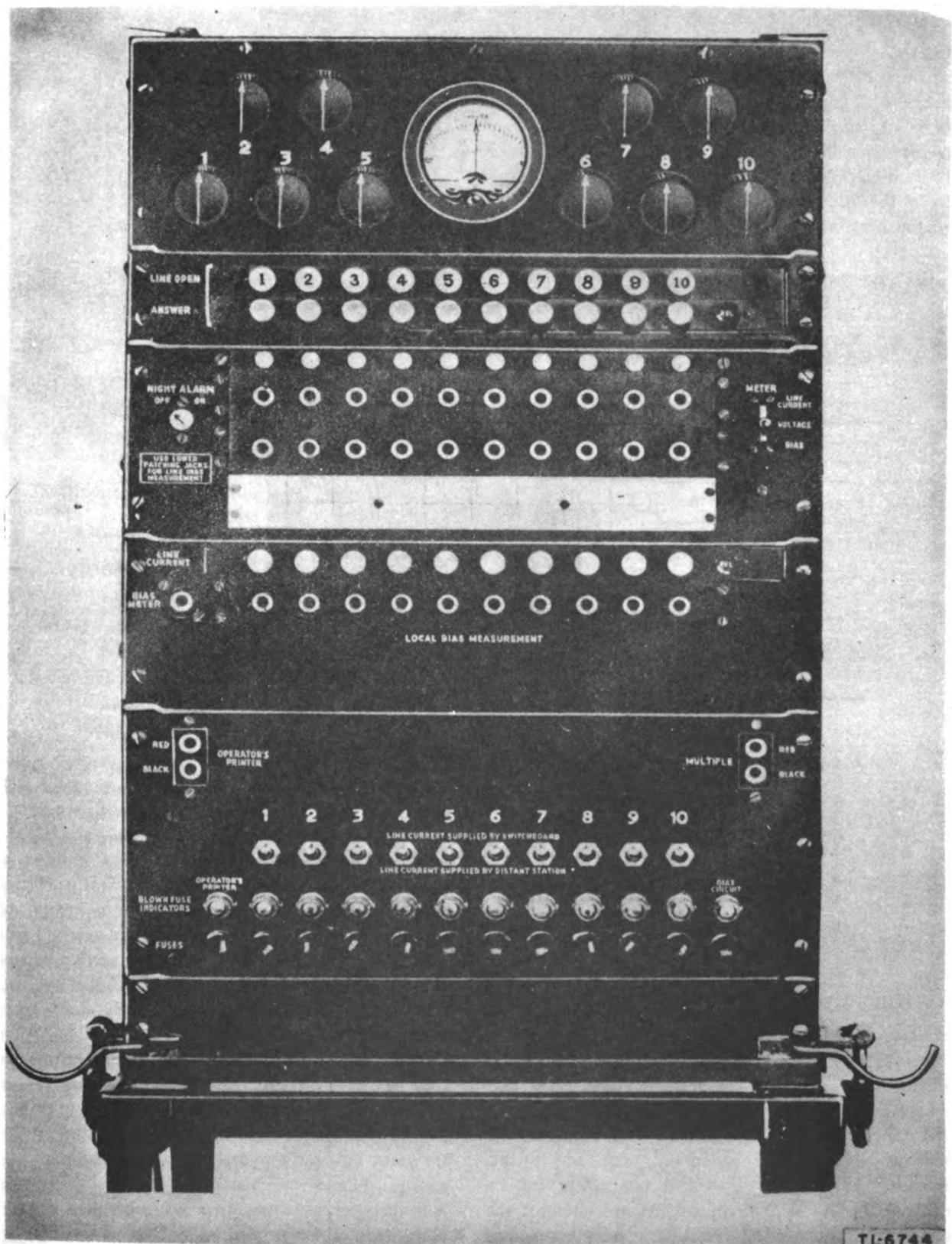

Figure 113. Switchboard BD-100.



TL-6744

Figure 114. Switchboard BD-100 front panel.

pairs of binding posts and a convenience outlet. Ten pairs of binding posts, marked LINE and GND, are for signal line connections. Another pair, marked FRAME and GND, is for grounding the frame and positive side of the power; the remaining pair, marked (-) and (+), is for d-c power connections. When another switchboard is connected in multiple, power for the second board is obtained from the convenience outlet on the terminal strip of the first board.

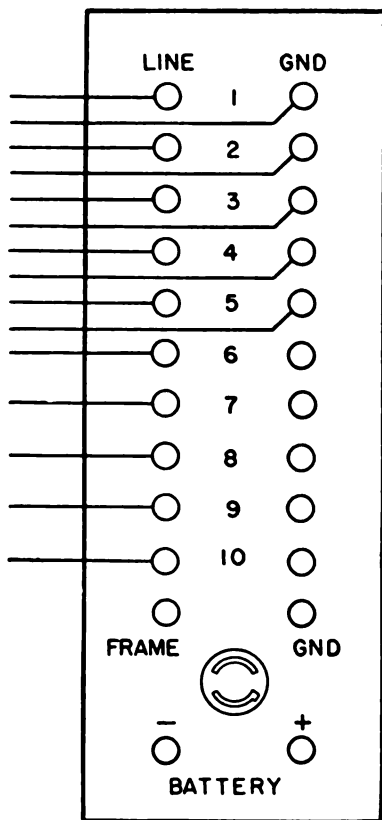

TL 50399

Figure 115. Switchboard BD-100, terminal strip.

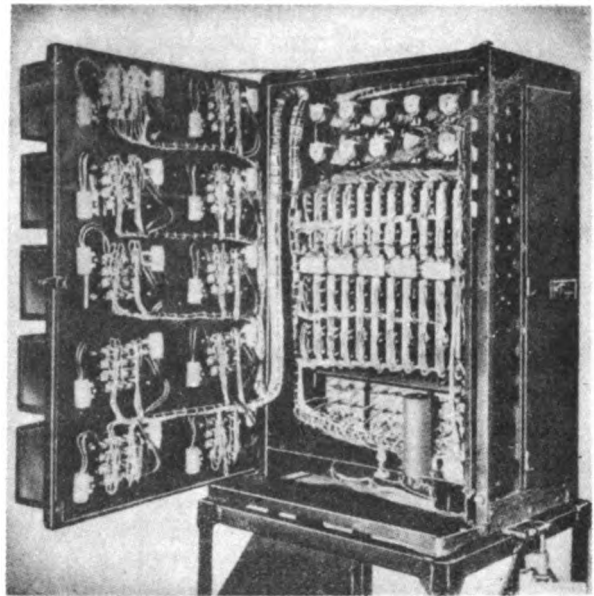

Figure 116. Rear view of Switchboard BD-100 with relay gate open.

69. Printer TG-7-A or Teletypewriter TG-7-B

For supervision and communication to stations connected to the switchboard, Printer TG-7-A or Teletypewriter TG-7-B with associated chests, is used as the operator's teletypewriter.

70. Rectifier RA-43-(*)

Rectifier RA-43-(*) (fig. 117) is a portable, self-contained unit for converting alternating current to direct current for operation of Switchboard BD-100 and its associated equipment. It also supplies a-c power for the operation of the operator's teletypewriter motor. It is assembled upon a heavy steel base to which are attached the power section, relay box, and control section. The power section consists of the plate transformer, the filter choke, the filter and power factor capacitors, and the tube socket sub-base. The base is supported by rubber shock mounts and in turn supports the rubber-mounted tube socket sub-base. The relay box incloses and protects the relay which is in the output circuit. The thermostatic switch, heater transformer, and the relay coil resistor are mounted above the power section. The control panel is a vertical steel panel and includes a voltmeter, circuit breaker or fuse, power switch, meter switch, high-low switch, and output voltage-adjusting potentiometer. The rectifier's choke coils and capacitors in the supply line

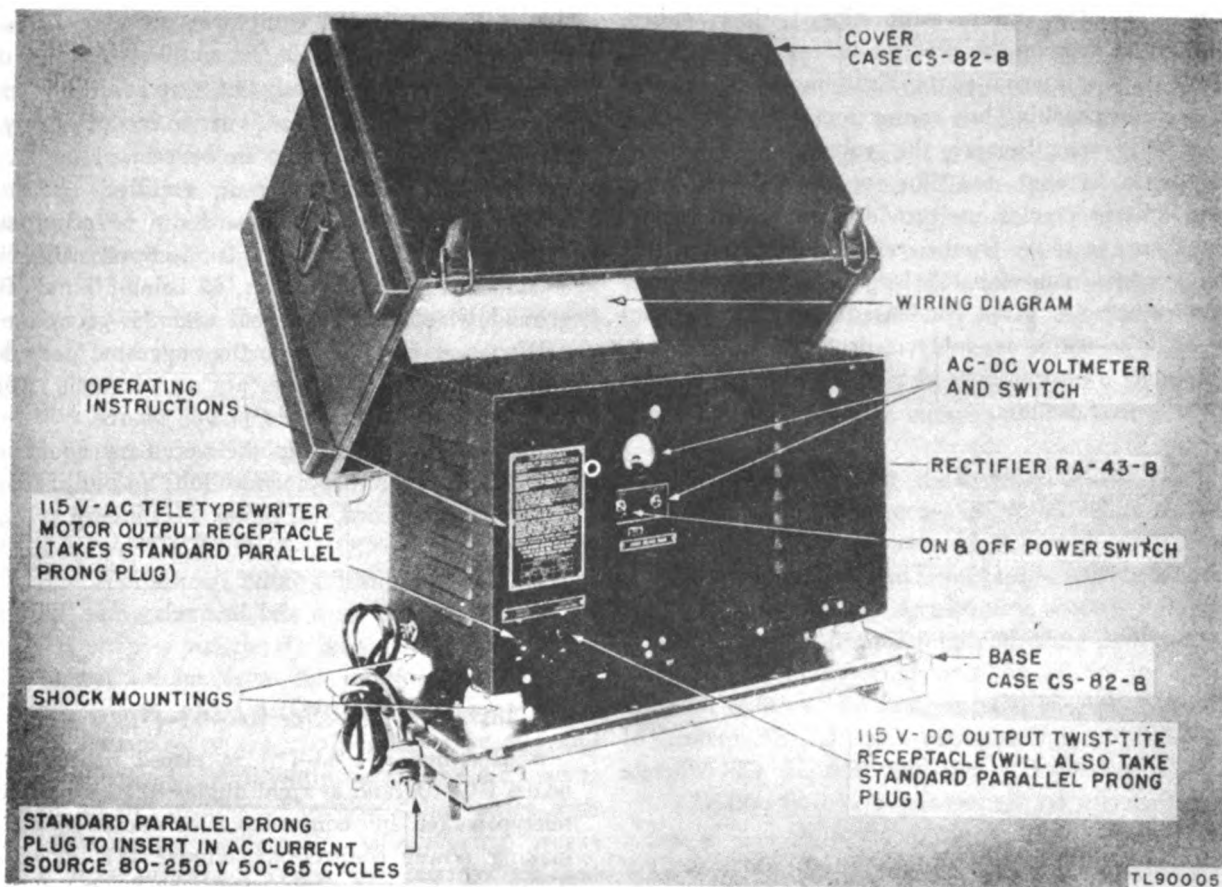

Figure 117. Rectifier RA-43-B with portable carrying case. Case CS-32-B.

reduce interference to nearby radio receiver equipment from the teletypewriter's motor outlet or the d-c outlet. Its resistors are treated with a special moistureproof coating to withstand tropical climate. The plated parts are protected by a zinc chromate finish, which produces a brown color and should not be mistaken for rust. Rectifier RA-43-(*) is strongly constructed and is shock-mounted on a wooden base to protect vital parts from being damaged while it is in field service. It operates from either a 100- to 125-volt or 200- to 250-volt, 50-65-cycle, single-phase power source. An extra transformer tap helps the rectifier operate properly even under conditions of abnormally low line voltages. This tap is used for an input voltage range of 80 to 100 volts and is selected by means of a toggle switch. (See fig. 118.) Operating parts are covered by a removable steel cover finished in black wrinkle and provided with ventilating louvers. A hinged door in the front of the cover permits access to the tubes, adjustable taps, circuit breaker, or fuse, etc. A cut-out in the door exposes the meter,



Figure 118. Rectifier RA-43-B, front view.

power switch, and meter switch, which are the only accessible control parts during normal operation of the equipment. For protection of equipment and

personnel, the cover, with hinged door closed, should be kept on the rectifier unless work is being done on the internal parts. Extreme care should be taken when making line connections and tests within the equipment because the voltage used is very dangerous if contacted. For output connections, a-c and d-c receptacles are provided in the lower left-hand corner of the front cover. These are designated by a metal nameplate. A larger metal plate above the receptacles gives condensed operating instructions. The entire assembly is protected in transportation by a heavy plywood case fitted to the wooden base with fasteners.

71. Rectifier RA-53

When stable 25-cycle, a-c power is normally available, Rectifier RA-53 can be used in place of Rectifier RA-43-(*). The former rectifier is normally not a component of Central Office Set TC-3 and must be requisitioned when needed in place of or in addition to Rectifier RA-43-(*). Rectifier RA-53 is larger and heavier than Rectifier RA-43-(*), and requires Case CS-87, instead of Case CS-82- (). Rectifier RA-53 will operate satisfactorily on frequencies up to 60 cycles.

72. Power Unit PE-75-(*)

Power Unit PE-75-(*), furnishes the 115-volt, 60-cycle, a-c power required by Rectifier RA-43-(*), and by the operator's teletypewriter. It is used normally in locations where no other power is available but may also be used to furnish power in emergencies. The unit is a gasoline-engine-driven alternator which produces 2,500 watts of power. Securely mounted in a skid-type base, it consists of a self-excited, pulley and V belts by a single-cylinder, air-cooled gasoline engine. Ignition wiring is shielded to prevent radio interference. Spare parts, a set of tools, and TM 11-900 are furnished with each unit.

73. Installation Procedures for Telegraph Central Office Equipment

Detailed installation procedure varies with the type of equipment available, the number of switchboards used, the location selected, the number of installers available, and other factors. With minor modifications, the procedure outlined in the following paragraphs for one switchboard and local power supply unit is adaptable to most situations. A dry location under cover is essential. The switchboard operator must have light; therefore, provision must be made for operation in blackouts. For the initial installa-

tion, set up only the equipment necessary to start operation of the office. If the rectifier or power unit is unnecessary immediately, set it up as an emergency power source. If the crew is large enough, many of the phases of the work can be carried on at the same time. The power unit, rectifier, operator's teletypewriter, and switchboard can be set up and preliminary adjustments and connections made while a suitable ground location is being found. The ground wire can be run out and the ground connection prepared. Steps in the suggested procedure are:

- a. Arrange for suitable power source.
- b. Unpack and set up the necessary equipment.
- c. Make preliminary connections and adjustments on the switchboard, including the line-up of local relays.
- d. Make and test ground connections.
- e. Connect the lines and line relay and line them up.

74. Installing Rectifier RA-43-(*)

a. Rectifier RA-43-(*), is placed near Switchboard BD-100 and at right angles to the operator's teletypewriter for convenience in operation and in making power connections. Figure 112 shows the Telegraph Central Office Set TC-3 set up. The following installation procedure applies to both Rectifiers RA-43-A and RA-43-B unless otherwise specified.

b. Before making any power connections, determine the frequency and voltage of the a-c power source. The frequency should be between 50 and 60 cycles. When gasoline engine power units are used, these data can be obtained from the unit nameplate. When military or commercial power sources are used, these data can be obtained from the agency furnishing the power. When such sources of information are not available, voltage and frequency data can sometimes be obtained from the nameplates of equipment already connected to the power source. WHEN THERE IS ANY DOUBT ABOUT FREQUENCY AND VOLTAGE FROM A COMMERCIAL OR MILITARY POWER SOURCE, USE THE POWER UNIT AND RECTIFIER. If there is no portable meter to measure the supply voltage conveniently, the rectifier meter can be used for this purpose when the door at the front of the rectifier is opened and the line tap (the flexible lead with a spade lug) is connected to the 230-volt terminal. (See fig. 118.) Then the a-c cord can be plugged in and the power

switch turned on. The voltmeter reading should be multiplied by 2 to obtain the correct voltage. If the voltmeter reads between 50 and 62.5 volts, the actual voltage of the power source would be 100–125 volts and the line tap must be changed (after turning the input power to OFF) to the terminal marked 115 which will cause the meter to read actual voltage. If the first reading is within the range of 100 to 125, keep the tap on the 230-volt terminal. When the line tap is used on the 115-volt terminal and the meter indicates a voltage of 80 to 100, place the toggle switch (a-c voltage) in the lower position (80–100) which will cause the voltage to be nearer the desired 115. NEVER OPERATE THE A-C VOLTAGE SWITCH IN THE 80–100 POSITION WHEN THE LINE VOLTAGE IS ABOVE 100. TO DO SO MAY SERIOUSLY DAMAGE THE EQUIPMENT. Because a time delay microswitch does not close until the bimetal strip is sufficiently heated, there will be no d-c output voltage from the rectifier for about 55 to 75 seconds after turning on the power. This prevents damage to the rectifier tubes by allowing them to warm up sufficiently before the d-c load is placed on the rectifier. The time delay varies with the temperature because the bimetal strip works on a heat principle. When the microswitch has closed, the d-c voltage can be read on the meter by holding the voltage toggle switch to the d-c position (down). If the microswitch has not closed, there will be no indication on the meter. If the meter indicates 115 volts, no further adjustment is needed. However, if the d-c voltage is greater or less than 115, it can be adjusted to the proper value by turning the potentiometer with a screw driver. When the screw driver is removed, make another check to see that no maladjustment has occurred. The correct d-c voltage, 115 volts, is designated by a red mark on the meter. In general, best operation is obtained when the upper electrode of the neon bulb is glowing. If the lamp has been reversed, the lower electrode will be glowing and the lamp should be turned around. After the rectifier is checked, close the hinged door and throw the OFF-ON switch to OFF.

75. Installing Switchboard BD-100

Switchboard BD-100 is best installed when it is easily accessible for operation and inspection. When a definite procedure is followed, the switchboard can be tested and lined up as the installation is being made. Some preliminary adjustments can be completed prior to power and line connections

which will position the keys, buttons, and switches in such a way that the meter and signal lamps will indicate when these connections are correct. When the line and power connections are made and tested, the installer can proceed without interruption on the line-up of the local and line relays.

a. PRELIMINARY ADJUSTMENTS. After Switchboard BD-100 has been set up and before the signal lines and power leads are connected, make the following adjustments:

(1) Turn all line rheostats so that the arrows point straight up. This will protect the equipment, yet will allow enough current to flow to operate the line relays.

(2) Force out all the LINE OPEN (white) buttons by depressing the ANSWER buttons. When the LINE OPEN buttons are out, the ANSWER buttons are released by depressing the release button. This will cause the signal lamps to light when the power is applied to the switchboard, allowing it to be tested.

(3) Remove all cords and plugs from the switchboard jacks. This prevents false indications.

(4) Set the METER key at VOLTAGE.

(5) Depress the release (REL) button for the line current buttons. All line current buttons must be kept out unless line current is being tested.

(6) Set all toggle switches at LINE CURRENT SUPPLIED BY SWITCHBOARD position. This will insure correct reading of the meter when checking local bias.

(7) Turn to their extreme marking position all line (WEST) and local (EAST) relay adjusting knobs; then turn back to spacing by one full turn. This assures the closing of the line relay when a small amount of current is flowing in the line circuit. These knobs turn very easily. They require only about two and one-half revolutions from one extreme to the other.

(8) Adjust the power-selector switch of the operator's teletypewriter for the power to be used. This assures correct operation of the motor of the printing unit.

(9) Arrange the power source to furnish 115 volts direct current for the switchboard and 115 volts alternating current or direct current for the operator's printer unit motor.

b. POWER CONNECTIONS. Each switchboard BD-100 is provided with a power cord which has spade terminals on one end (with polarity indicated) and a twist-type polarized plug on the other end. The spade terminals (positive and negative) should be

connected to their respective switchboard battery terminals and the twist-type plug inserted into the 115-volt d-c switchboard receptacle of the rectifier or other suitable d-c source. When the a-c power to the rectifier is turned on and the microswitch operated, the voltage indicated on the switchboard meter should read to the right of zero approximately on the center mark of the three red marks. If the meter reads to the left, remove the plug from the source of direct current and reverse the connections to the switchboard battery terminals. If the voltage reading is above or below the red marks, check and rearrange the power source. If one side of the power source is grounded, take great care in connecting power to the switchboard so that the grounded side of the power system terminates at the grounded side of the switchboard. If these connections are not correctly made, the ground at the switchboard will cause the power source to be shorted. If the negative lead of the power system is grounded and the power leads are correctly connected, all switchboard meter readings will be reversed. All signal lamps should light when power is applied to the switchboard and should be extinguished by the depression of the line open buttons. This will cause the lamps to light automatically when a line circuit is completed to its associated terminals.

c. OPERATOR'S TELETYPEWRITER. The operator's teletypewriter, either Printer TG-7-A or Teletypewriter TG-7-B, is used in conjunction with Switchboard BD-100 for monitoring, supervising connections, and answering calls. Set it up so that the operator can reach all keys, buttons, switches, etc., of Switchboard BD-100 without changing position. The power cord of the operator's teletypewriter is connected to the rectifier 115-volt a-c PRINTER receptacle or other 115-volt a-c or d-c source. Insert the operator's printer send and receive plugs into the red and black operator's printer jacks on the switchboard, thereby connecting the operator's send and receive circuits to the switchboard. This allows the operator's teletypewriter to run closed and the motor speed to be checked. This is important because improper speed of the motor may result in poor adjustment of both the local and the distant relays. If the setting of the range finder is wrong, the operator may be unable to receive readable copy from some outlying station; therefore, the operator's machine must be oriented. To test and orient the machine, a local circuit within the switchboard must be provided. This can be done by depressing the

No. 1 answer button and patching from the bias meter jack to the No. 1 local bias measurement jack, using one of the patching cords furnished with the switchboard. Remove this connection when orientation of the operator's teletypewriter is completed. To protect personnel from electrical shock, ground the operator's teletypewriter by the connection of one of the knurled keyboard thumbscrews to a separate ground rod.

d. ADJUSTMENT OF LOCAL RELAYS. The transmitting contacts are connected by the answer button to the winding of the local relay. The transmitting contacts operate the local relay which repeats the signals over the line to the distant station. The relay, therefore, must be correctly adjusted to repeat perfect signals (zero bias). To adjust the No. 1 local relay, the BIAS METER jack is patched to the local bias measurement jack of line No. 1. The answer button of line No. 1 is depressed, the toggle switch is thrown to LINE CURRENT SUPPLIED BY SWITCHBOARD, repeated space signals are sent from the operator's teletypewriter, and the METER key is thrown to BIAS. The local (EAST) relay knob is then turned until the meter needle is oscillating above the zero mark. Bias all local relays before connection of the signal lines, and return all switches, buttons, etc., to their proper positions. To prevent damage to the meter, return the METER key to VOLTAGE position while space repeat is being received by the relay. NEVER have the METER key at BIAS unless space repeat is being received. If full-scale deflection is indicated when biasing a relay, return the key to VOLTAGE until the relay knob is turned far enough to cause the meter needle to oscillate near the zero point.

e. GROUND CONNECTIONS. A low-resistance ground connection is highly important, especially if more than two ground-return lines are operated from the switchboard. High-resistance ground connections introduce so much resistance into a circuit that it will be impossible to obtain proper operating current. High-resistance ground connections are likely to change rapidly with the weather and therefore need readjustments or line-up of the circuit. Finally high-resistance ground connections introduce unwanted coupling between different circuits. This coupling causes interference and leads to errors in message transmission, particularly when several lines are used for a conference call. A ground-connection resistance of less than 50 ohms generally will be satisfactory. If a water system, well pipe, or other

large, well-grounded metallic object is available, use it for a ground connection. Avoid grounds used for power systems, telephone instruments, and lightning arresters. If two ground rods are used, use a twisted pair with a single wire on each ground post and both wires connected to the bottom ground binding post of the switchboard.



Figure 119. Meter of Switchboard BD-100 with correct position of meter needle for zero bias.

f. SIGNAL LINE CONNECTIONS. After switchboard power and ground connections are made and the preliminary adjustments completed, the signal line connections may be established and the circuit line-up performed. Place the toggle switch in the lower position while connecting to the signal line; this will eliminate the danger of electrical shock. Connect the signal line conductors to the terminals marked LINE and GND, on the terminal strip behind the door in the left side of the switchboard cabinet. When ground return lines are used and one wire of the pair is grounded at the distant station, connect the ungrounded wire to the left line terminal (marked LINE). The white designation strip beneath the line jacks on the front of the switchboard is provided for marking (in pencil) call signs, station names, or other identification. For a rapid and efficient installation, there must be a definite procedure. Normally, the switchboard is the control station. When two switchboards are connected by a trunk line, the station of higher authority is the control station; if the two stations are of equal authority, the one with the lower number will control the circuit and its line-up. The general procedure is to connect the line, adjust the line current, adjust the switchboard line relay for zero bias, and then adjust the distant station line relay for zero bias. The detailed procedure given in (1) below is based on controlling, at the switchboard, the line-up of the No. 1 switchboard line to a distant station. The process is simply reversed when the line-up

is controlled from the distant station. The same procedure is applied to each of the other lines.

(1) *Line current adjustment.* Line current is normally supplied by the control terminal only; if the circuit is long enough to require battery supply at both ends, positive battery (negative grounded) will be supplied by the noncontrol station. Never attempt to supply battery from both ends of a circuit which has switchboards at both ends because battery would have to be reversed at one of the switchboards. The only way this can be done is by reversing the power leads at the switchboard. This will reverse the direction of the current flow in all circuits associated with that switchboard. When the line is connected at the substation (noncontrol), the signal lamp of the line on Switchboard BD-100 will light, indicating a completed circuit. The switchboard installer then depresses the answer button which connects the operator's teletypewriter with that line and releases the line open button which will extinguish the lamp. After depressing the answer button, he depresses the No. 1 line current (red) button and operates the METER key to LINE CURRENT. The switchboard installer then adjusts the No. 1 line rheostat knob on the top switchboard panel until a line current of 75 ma is indicated on the meter. If about 75 ma cannot be obtained, he sets the rheostat for the highest current obtainable and sends two 5-second break signals with his teletypewriter. This notifies the distant station attendant to proceed with line current adjustment. The switchboard installer continues to watch his line current meter for signals from the distant station attendant. The line current at the distant station is decreased from about 75 ma to 60 ma with the line rheostat. *If the line current is already between 50 and 60 ma, no such adjustment is made.* If the line current is below 50 ma, the noncontrol station attendant arranges to supply battery to the line if possible and then increases the line current to 75 ma. He sends two 5-second break signals to notify the switchboard installer to adjust line current to 60 ma. After adjusting the line current to as near 60 ma as possible, the switchboard installer sends two 5-second break signals, indicating that this adjustment has been made. If this procedure results in a current reading of 35 to 50 ma, the circuit will usually operate satisfactorily.

(2) *Adjustment of line relays.* After reducing the current to 60 ma, the distant station attendant sends repeated space signals. This permits the switchboard installer to adjust the line relay by

connecting the BIAS METER jack to the lower No. 1 line patching jack, operating the METER key to BIAS and adjusting the No. 1 line relay (WEST) until the switchboard meter indicates zero. The switchboard installer returns the METER key to VOLTAGE, removes the patching cord, first from the line jack, then from the BIAS jack, and sends two 5-second break signals to indicate that he has finished his line relay adjustment. He then sends repeated space signals by holding down his space bar until he receives two 5-second break signals from the noncontrol station. These signals indicate that the distant station has completed the relay adjustment and the switchboard operator should stop sending.

(3) *Test copy.* After the relay at each end is adjusted, send test copy in both directions between the noncontrol station and the control station, using breaks for signaling. Receipt of accurate copy at both ends indicates that the line-up is correct and that the circuit is ready to handle traffic.

(4) *Emergency arrangements.* All relay assemblies (LOCAL and LINE) are jack mounted and are easily interchanged or can be taken out and one of the two spares used. If there is internal circuit trouble, the line connection on the terminal strip can be moved to an unused switchboard circuit. If it is impossible to obtain zero bias at a substation, the switchboard installer sends R's and Y's, which allow the substation attendant to orient his machine on signals repeated by his relay. After all lines are lined up, the switchboard normally requires the following occasional checks:

(a) Check the line current to see that the reading has not changed. If a change is indicated, check the voltage of the power source and readjust it if necessary, because any change in voltage affects the line current. As the load is varied, the voltage of the power source may change, especially if a power unit is used. For example, if a Telegraph Central Office Set TC-3 is installed and lined up, using Power Unit PE-75-(*) as a power source of 115 volts alternating current with only the rectifier connected, any additional heavy load, such as a number of lights, telephone equipment, etc., will lower the output of the power unit. After readjustment of the voltage, line current of all lines connected to the switchboard must be checked and, if necessary, readjusted.

(b) Received copy of the operator's teletypewriter must be checked for errors. If any are found, check the line relay and readjust it if necessary.

(c) If the line condition changes after the original circuit line-up, check the relay adjustment even though accurate copy is received. Line conditions may alter with changes from wet to dry weather and between night and day conditions.

(d) Check both line current and relay adjustments if the line circuit has been out of operation for more than a few hours.

(e) Any need for considerable readjustment of line current indicates a high ground resistance. This should be reduced.

(f) Make periodic checks and tests during hours of the least traffic.

76. Testing Ground Connections

a. **SINGLE GROUND CONNECTION.** When ground-return circuits are to be used in conjunction with a switchboard, test the ground connections before the switchboard is turned over to operating personnel. When only a single ground such as a water pipe is used, check its resistance by connecting two ground return circuits to the terminal strip and adjusting the line current in each to 60 ma. If the current increases less than $1\frac{1}{2}$ ma in one line when the other is "opened," the ground connection is good and has a resistance of less than 30 ohms. If the current increases more than $2\frac{1}{2}$ ma, the ground is not as good but may give satisfactory service. Its resistance is then about 60 ohms. If the current increases 4 ma or more, the ground resistance is very likely to cause interference between lines, as well as to make adjustment of line current and relays very difficult. In this case a better ground location must be found. This method of testing grounds can be used when more than two lines are connected to a switchboard by opening, with patching cords, all the lines except the two used for the test.

b. **DOUBLE GROUND CONNECTION.** When two ground rods are used and separate leads are brought to the switchboard from each, their ground resistance can be checked without the use of ground-return line circuits, by connecting one ground rod to the switchboard ground terminal. After the line rheostat of a line not being used is turned counterclockwise all the way, connect the other ground rod to the line terminal of the unused line, and place a short between the line terminal and the adjacent ground terminal. Then adjust the rheostat to 60 ma through the short, and open all other lines connected to the switchboard. When a short is taken off, if the current as indicated by the meter decreases less than $3\frac{1}{2}$ ma, the ground is good and has a resistance of

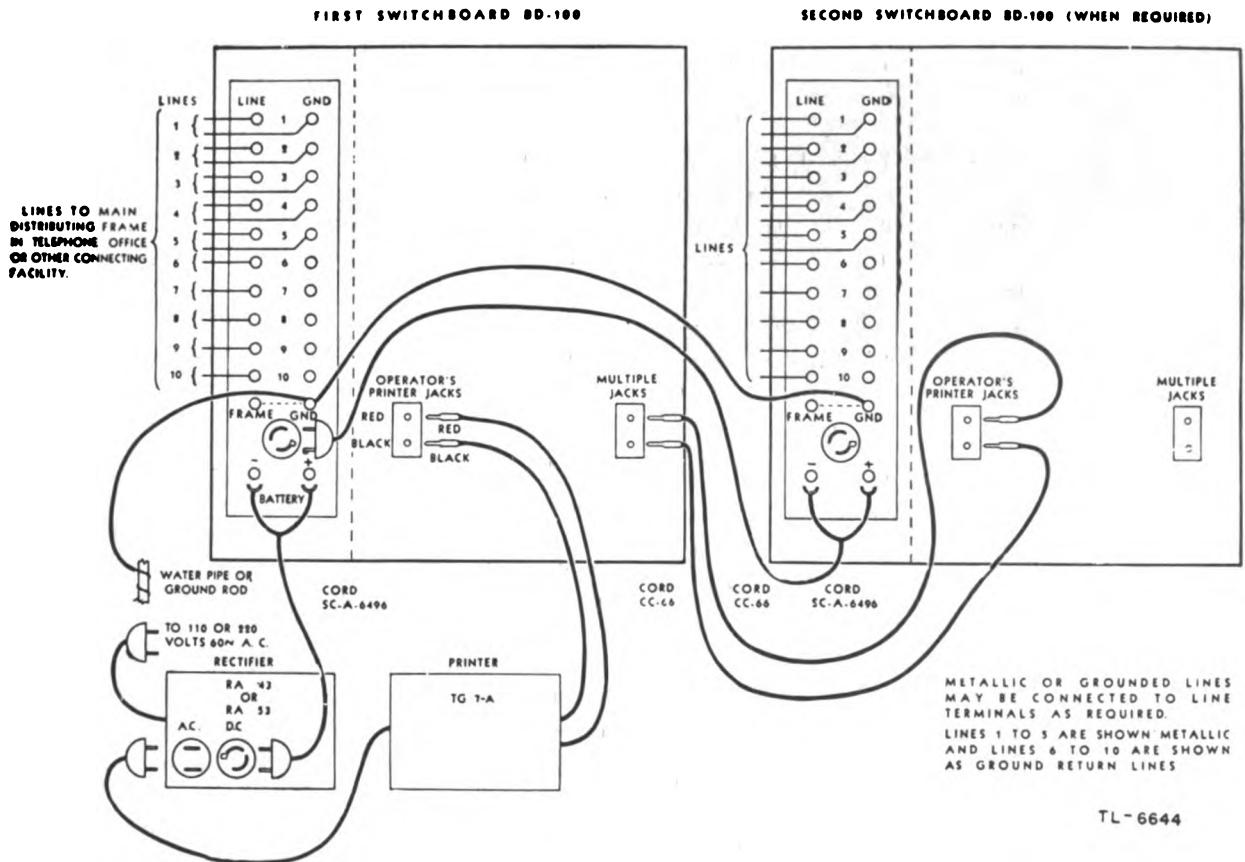

Figure 120. Cording connections for two switchboards in multiple.

30 ohms or less. If the current decreases about $6\frac{1}{2}$ ma, the ground is not so good but will probably give satisfactory service. If the current decreases more than $6\frac{1}{2}$ ma, the ground is unsatisfactory and a better ground location must be found. After the ground test is completed, both ground wires must be connected to the switchboard ground terminal.

77. Connections of Switchboards in Multiple

Though Telegraph Central Office Set TC-3 is equipped to handle 10 teletypewriter lines, the situation arises in the field oftentimes when a switching central is needed to handle an even larger number of lines. This can be arranged by the addition of one or two switchboards, permitting the use of up to 30 lines with Rectifier RA-43-(*) as the power supply for all of them. The position of the additional switchboards should be similar to the position of the first with respect to ease and convenience in operation and inspection. Figure 120 shows cording connections for two switchboards in multiple. To connect one Switchboard BD-100 to another for multiple operation, the two operator's printer jacks

on the second switchboard are patched to the multiple jacks of the first switchboard. In making this patch, the operator's top printer jack is connected to the top multiple jack, and the operator's bottom printer jack to the bottom multiple jack. The cord must always be connected first to the printer jack, then to the multiple jack. Power for the second switchboard is obtained from the convenience receptacle of the first switchboard. Ground is obtained by connecting the two switchboard ground terminals. Interconnection of a line from one switchboard to a line from the other is performed with the long patching cords which are issued with Chest CH-70, a component of Telegraph Central Office Set TC-3. When switchboards are connected in multiple, only one operator's teletypewriter and one power source is used. The ANSWER buttons are not interconnected mechanically from one switchboard to another. Therefore the release (REL) button is not operated after each call unless another button on that same switchboard is to be operated. Not more than three switchboards can be connected in multiple when only one Rectifier RA-43-(*) is used.

78. Operation of Switchboard BD-100

To install and maintain a teletypewriter switching central properly, a teletypewriter mechanic must thoroughly understand the switchboard's operation. Actual operation of Switchboard BD-100 is not difficult, because the front of the switchboard is practically self-explanatory. For example, the signal lamps are used for signaling the operator of the switchboard; the ANSWER buttons are for answering the signal; the patching jacks are for patching two or more stations together; and the LINE CURRENT buttons are for measuring line current. Basic operational procedures which will apply to most installations are outlined in the subparagraphs immediately following. However, these procedures must not be considered standard.

a. CALLING SWITCHBOARD OPERATOR. The station operator who wishes to make a call depresses his break key for 3 seconds. This break signal starts his own teletypewriter motor and lights the signal lamp at the switchboard.

b. ANSWERING INCOMING CALL AT SWITCHBOARD. When the operator sees the lamp on the switchboard lighted, he presses the ANSWER button directly above the lighted lamp. Then from his teletypewriter keyboard, he sends LTRS, CAR. RET., LINE FEED, and the switchboard call or sign followed by /OPR and K (go ahead). This procedure will have extinguished the lamp, arranged both the calling teletypewriter and the switchboard operator's teletypewriter so that they print on unused lines, and informed the calling operator that the switchboard is ready to receive calling instructions.

c. COMPLETING THE CONNECTION. (1) The calling operator sends, in alphabetical and numerical order, the call signs or names of all stations to which he wishes to send a message.

(2) The switchboard operator plugs one end of a patching cord into the lower jack of the first called station, waits 3 seconds, and plugs the other end of the patching cord into the upper jack of the calling line. Patching in this way assures the release of the called station's mechanical motor stop.

(3) The switchboard operator plugs one end of another patching cord into the lower jack of the second called line, waits 3 seconds, and plugs the other end of the patching cord into the upper line jack of the first called line.

(4) The remaining called lines are connected in sequence by connecting their lower jacks to the upper jacks of the last connected lines, as in the previous examples.

(5) The switchboard operator sends in the order named: FIGS, BELL (three times), LTRS, CAR. RET., LINE FEED, call signs or names of all called stations in sequence, the letter V (from), the call sign or name of the calling station, and the letter K.

(6) Each called station answers in sequence with its call sign or name followed by the letter K. This indicates to the switchboard and calling operator that the connection is complete and the calling station's message can be sent.

(7) The operator then presses the REL button for the ANSWER buttons in order to remove his teletypewriter from the connection.

d. RECALLING THE SWITCHBOARD OPERATOR. A 3-second break signal is used by any one of the connected stations to recall the switchboard operator at any time during a conference. The switchboard operator answers in the same manner as indicated in *b* above.

e. MONITORING COMPLETED CONNECTIONS. The switchboard operator can monitor any connection without interference to traffic on the conference by pressing the ANSWER button of any one of the connected lines.

f. DISCONNECTING. Upon completion of a message, the calling operator recalls the switchboard operator with a 3-second break signal, receives the switchboard operator's challenge (his call sign followed by K), and immediately sends the letters CLR as a clearing signal. The switchboard operator then removes the patching cords from the connection in reverse sequence. Each station operator waits 10 seconds after receiving the clearing signal and then stops his machine, operating the motor stop.

g. UNCONNECTED OR OPEN LINES. When switchboard lines are not to be used, or when lines in use go open in service, depress the LINE OPEN buttons associated with those lines. Then, when the line is connected or closed, the associated line lamp will light, indicating that it is again in operating condition. All signal lamps should be kept off to permit proper signaling.

h. NIGHT ALARM KEY. The night alarm buzzer will sound whenever a lamp lights if the NIGHT ALARM key is at ON. The alarm continues until the lamp is extinguished.

79. Typical Large Teletypewriter Switching Central

Circumstances arise in theaters of operation which require teletypewriter switching centrals capable of

handling more than 30 teletypewriter lines, and for this purpose large centrals can be devised that will permit supervision and direct interconnection of teletypewriter lines on as many Switchboards BD-100 as are needed. Installations of this type generally consist of three individual steps: Temporary installation, semipermanent installation, and permanent installation. Information contained in this section pertains to large switching centrals of four or six switchboards but may be applied to centrals using a greater number. If a thorough knowledge of the installations outlined in this section is gained, no trouble is likely to be encountered in the installation of any large switching central, regardless of size or type.

80. Temporary Installation

a. **VARIOUS COMBINATIONS.** The temporary installation of a large switching central is simply a combination of four or more Switchboards BD-100 and may be installed by using the same procedure as with a single switchboard excepting that another power source is added and multiple connections are made between boards. The number of lines necessary to handle the anticipated traffic will naturally determine how many switchboards are necessary. All equipment must be arranged for ease of operation and maintenance. Ground and signal lines must be neatly run and connected securely if interruptions in service are to be avoided. When lines are tagged, they simplify tracing of individual circuits. This practice should be considered a necessity because the immediate location of trouble is such an important factor in maintaining uninterrupted operation. In this section the example described is a four-switchboard set-up as a temporary installation with supervision by two operators' teletypewriters.

b. **EQUIPMENT ARRANGEMENT.** Equipment must be arranged so that the temporary large switching central will be compact, efficient, and easy to operate and maintain. The switchboards are mounted adjacent to one another and the operators' teletypewriters are located in a manner that will permit operators to do their work with minimum effort. Locate the rectifiers where they are out of the way but convenient for adjustment and line-up. Figure 121 shows a recommended arrangement for a temporary large switching central comprised of four switchboards, two operator's teletypewriters, and two rectifiers. Remember that this is only a recommended arrangement is dictated in the field oftentimes by variation in available space and the amount of equipment to be used.

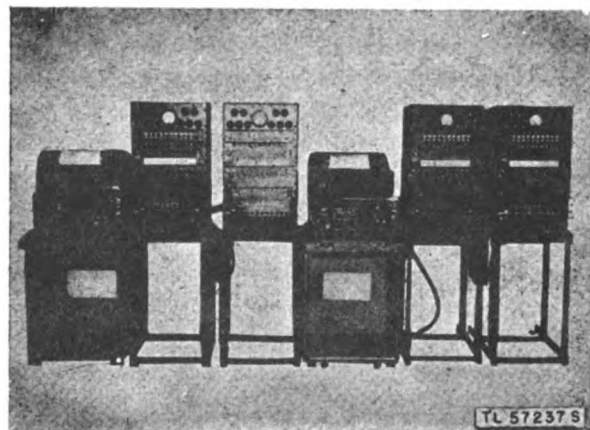

Figure 121. Recommended arrangement for temporary large switching central.

c. **PRELIMINARY ADJUSTMENTS.** Once the equipment has been arranged satisfactorily, preliminary adjustments must be made in preparation for the complete setup for multiple connection as well as for connection of power, ground, and signal lines. The preliminary adjustment procedure to be followed is described in paragraph 75.

d. **POWER CONNECTIONS.** The 115-volt d-c power source capable of delivering 1.5 amp to each switchboard of the large teletypewriter switching central can be obtained from any stable source, either military or commercial. Normally, however, only alternating current is available and Rectifiers RA-43-(*) or RA-53 must be used. If rectifiers are used, a source of alternating current that is capable of delivering approximately 1,000 watts at each rectifier is necessary. In addition 100 watts must be supplied for the motor of each operator's teletypewriter. Each rectifier is capable of supplying direct current for as many as three switchboards. In the four-board set-up, two rectifiers are needed but another two switchboards may be added (one to each rectifier) without overloading. As figure 122 shows, each pair of switchboards is supplied direct current by one rectifier. The power leads are connected from the d-c outlet of the rectifier to the battery terminals of one switchboard, and the second board is connected to battery by multiple connection to the convenience outlet. The other pair of switchboards is connected to their rectifier in like manner. Correct polarity is indicated on the spade terminals of the power leads that are supplied with each Telegraph Central Office Set TC-3. Check the polarity when power is applied by referring to the meter of one of the switchboards. The meter should indicate the proper amount of voltage by the needle moving to

the right of zero. Tape or otherwise hold down all power leads to prevent their being accidentally disconnected.

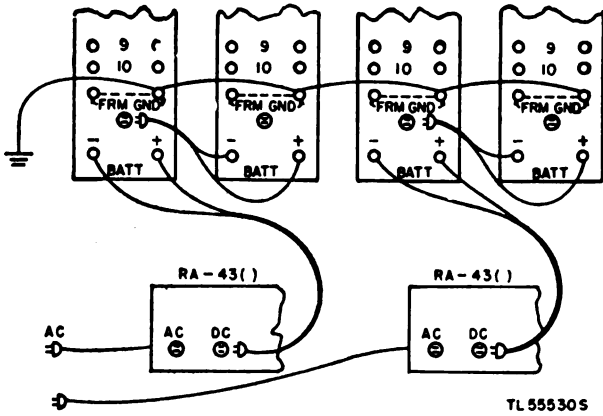

Figure 122. Power and ground connections for a large switching central.

e. OPERATORS' TELETYPEWRITERS. A switching central in which there are four Switchboards BD-100 normally requires two operators' teletypewriters for supervision and monitoring. Each teletypewriter is connected to a switchboard in the usual manner, and a second switchboard is connected in multiple. When these connections are made, the central appears as two separate installations (fig. 123) but the ground lead makes it possible to interconnect any two or more lines of the four switchboards. The longest patching cords with which the telegraph central office set is equipped are 72 inches long, but longer cords can be made if plugs and rubber covered a-c wire are available. It is a good plan to make patching cords of various lengths so that they can be used without interference with each other. Be careful when making cords to be sure that on each one the tips are connected, and also that the sleeves are connected. Power for teletypewriter motors is obtained from the a-c outlets of the rectifiers.

f. GROUND CONNECTIONS. To all four switchboards, connect the ground binding posts of all switchboards together (fig. 122) and run a ground lead from one switchboard (usually an end one) to a suitable earth connection. It is important that the earth connection be tested as described in paragraph 76 to insure low resistance and to guard against cross-fire. Ground the frame of each switchboard to protect the equipment. In a switching central which uses more than three switchboards, install a ground at each Switchboard BD-100 regardless of the type of lines connected. Unless each switchboard is

grounded, interconnection of all signal lines cannot be accomplished.

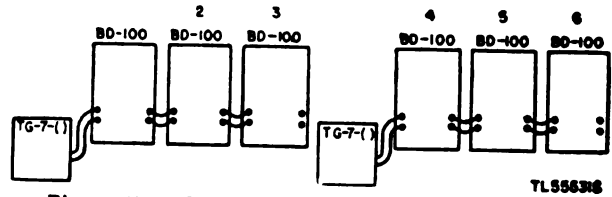

Figure 123. Connection of operators' teletypewriters.

g. LOCAL CHECK OF EQUIPMENT When the equipment comprising the temporary large switching central has been connected to the power source and multiplied, check it locally in preparation for signal line connections. The procedure for checking the equipment is the same as for checking a single-switchboard installation (voltage and local relay bias adjustment, etc.).

h. CONNECTION, LINE-UP, AND PATCHING OF SIGNAL LINES. Steps taken for connecting, lining-up, and patching signal lines of a large switching central are the same as for a single-switchboard central. Probably it will be necessary to rearrange signal line connections after the central has been opened to traffic in order to distribute evenly the amount of traffic handled by each operator.

81. Semipermanent Installation

The temporary large switching central can be set up and put into operation in a relatively short time and is therefore an advantage over a large, time-consuming installation. However, there are often certain disadvantages experienced after a station of this type has been established. One of these is that much time is consumed unnecessarily in answering, patching, and disconnecting circuits because associated panels of the switchboard are out of reach of the operators. This can be overcome in many instances if a stand for the switchboards and operators' teletypewriters is made. Figure 124 is a recommended set-up for a semipermanent installation. It shows the position of the switchboard panels with respect to the operators. The stand in this example is made of scrap angle iron but a similar frame can be made of lumber. Another operator's teletypewriter is added to the installation. It can be used when traffic is too heavy to be handled efficiently by two operators. It may also be used as a substitute for one of the other teletypewriters in the event of a breakdown and at servicing periods. It is likely that as time goes by a greater number of lines will be needed, making the third teletypewriter

necessary. One major change is made at each switchboard. The patching jack and meter control panels are interchanged so that the patching jacks can be reached by operating personnel with less effort than would otherwise be possible. To do this, new holes are drilled and tapped for the panel screws, but no new cabling or wiring is involved. The rectifiers can be located on the floor inside the stand, and there be out of the way yet still accessible. Power; ground and signal line connections are the same as for a temporary installation. So, too, is the procedure for patching signal lines. The semipermanent installation may be enlarged, if necessary, by addition of more Switchboards BD-100.

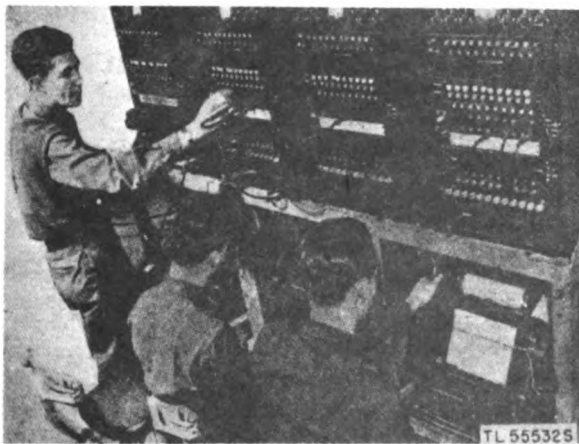

Figure 124. Recommended equipment arrangement for semipermanent installation.

82. Permanent Installation

Because all equipment can be located and connected in a permanent manner, assuring fewer breakdowns in communication, a permanent installation has definite advantages over a semipermanent one. Operation and maintenance are more easily accomplished, and the entire installation can be set up in a neat, compact manner, allowing definite routine. Equipment used in this type of installation can be arranged on rugged platforms and located as close as possible to terminating equipment and power outlets. There must be ample room on all sides of the assembly for freedom of movement for operators and maintenance personnel. There must be efficient lighting arrangements. The installation illustrated in figures 125 and 126 as described in *a* through *e* below is merely a recommended lay-out because the amount of equipment necessary, the amount of traffic, etc., will determine the size and type of switching central needed. In figures 125 and 126 the

permanent type installation shown is comprised of six switchboards, three operators' teletypewriters (Teletypewriters TG-7-B), and two Rectifiers RA-43-B. A total of 60 lines may be used with interconnection of any two or more. Preliminary adjustments, local check, and line-up of the equipment are performed in the same way as with temporary and semipermanent type of switching centrals.

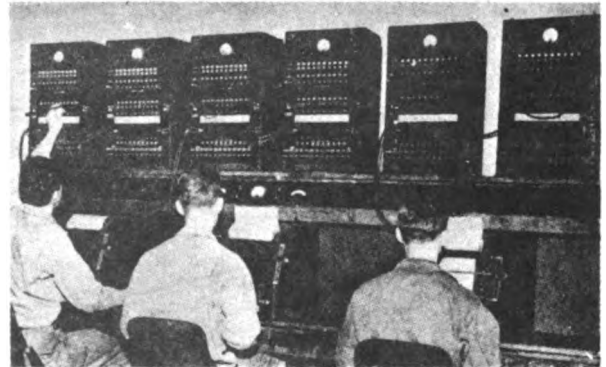
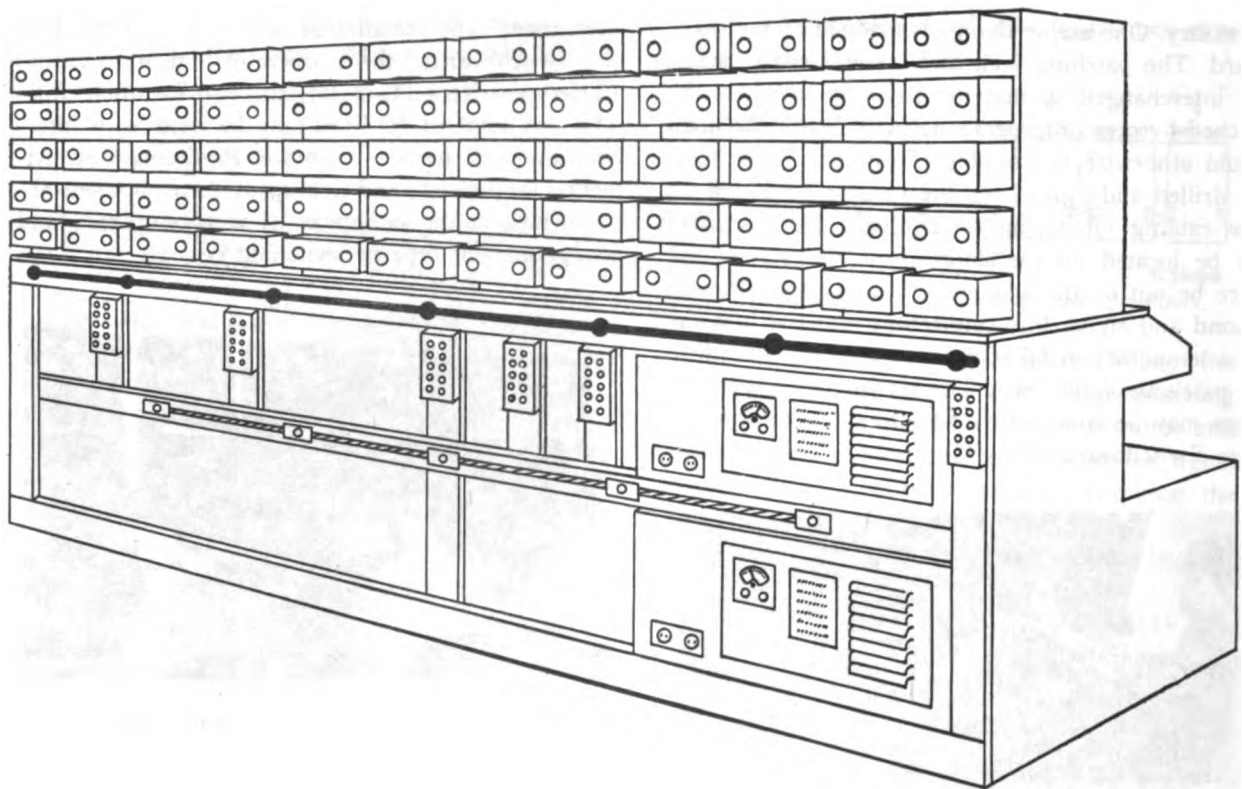

Figure 125. Front view of permanent large switching central.

a. POWER CONNECTIONS. Power leads between switchboards are installed in the same way as in temporary and semipermanent installations. However, in figures 125 and 126 another switchboard is added to each rectifier. The direct current for operation of the switchboard comes from the convenience receptacle of the adjacent switchboard in each case. The main power lead to the installation must be of sufficient gage to carry 20 amp of alternating current because up to that amount may be drawn by the rectifiers and teletypewriter motors. The power lead is run to five a-c outlets that are distributed along the rear of the platform for connections of the rectifiers and teletypewriter motors. If it is possible, run this wiring in conduit or use armored cable (BX). Be careful when the power lead is installed to see that all wiring is protected from wear and that plant personnel cannot come in contact with any part of the wiring. A full-locking, twist-type (nonpolarized) plug used at the wall outlet provides a way of keeping a secure connection and at the same time gives maximum safety. Locate the rectifiers in specially constructed compartments within the platform where adjustments can be made easily.

b. OPERATORS' TELETYPEWRITERS. Generally, two operators' teletypewriters are enough to handle the traffic load of a six-board set-up. However, it is



TL 555348

Figure 126. Rear view of permanent large switching central.

necessary to have a third teletypewriter installed in the platform for use in case of traffic increases, servicing periods, or break-downs. Tilt the machines backward slightly to bring the keyboards nearer the patching jacks panel which is interchanged with the meter-control panel for ease of operation. Run the power cords for the teletypewriter motors through the platform and connect them to the installed a-c receptacles in the rear. If it is necessary, improvise patching cords of various lengths to interconnect the signal lines. When only two operators are necessary, the machine on the extreme right is not used. Each of the other two machines is connected to three switchboards.

c. GROUND CONNECTIONS. A heavy copper ground wire with seven binding posts is located along the rear of the platform. (See fig. 126.) Six of these binding posts are to secure leads from the ground terminal of each switchboard; the remaining one is to connect the lead from the earth connection. *A good ground is even more important in a permanent installation than in a semipermanent installation because, normally, more signal lines are involved.*

d. SIGNAL LINE CONNECTIONS. Ten-pair terminal blocks are located at the rear of the assembly

(fig. 126), just below each switchboard. They are provided for connection of signal lines from the terminal equipment to the switchboards. Use of these intermediate terminal blocks is not necessary but they do provide a means whereby changes in signal line connections can be made quickly and easily. If available, 10-pair cable can be used to good advantage for signal line connections from the terminal equipment to the intermediate terminal blocks. The cable is installed permanently, and all changes are made on the switchboard side of the intermediate blocks and at the terminal equipment. If other types of wire are used, run them in cable form and tag each individual circuit. The individual circuits need not be tagged when cable is used as the color code of the cable aids in circuit tracing.

e. ANSWERING AND CALLING CORDS. It is advisable in some permanent installations to devise and construct answering and calling cords for use similar to answering and calling cords of a telephone switchboard. This will facilitate rapid connection of one line circuit to another and provide a somewhat easier means of supervising the connection. If answering and calling cords are used, they may be devised from the circuit illustrated in figure 127.

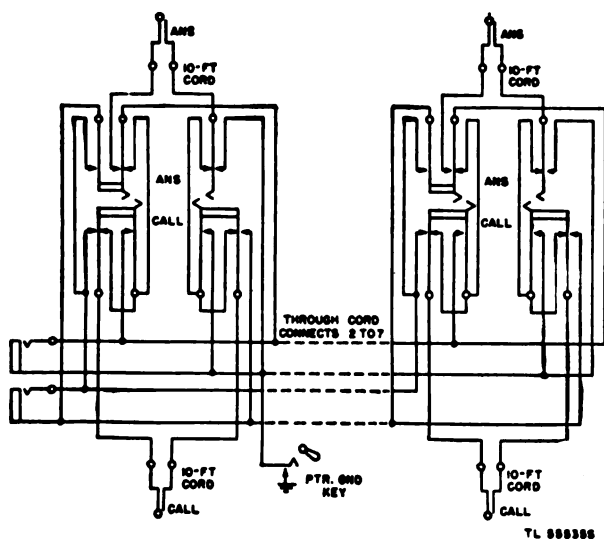

Figure 127. Schematic of circuit for use of answering and calling cords.

Section IV. MAINTENANCE PROCEDURES FOR SWITCHBOARD BD-100

83. Use of Schematic and Actual Wiring Diagrams

a. The teletypewriter mechanic must thoroughly understand Switchboard BD-100 and its associated circuits if he is to locate and correct accurately any electrical or mechanical troubles which may occur within the switchboard. Practically all repair and maintenance of the unit is done by teletypewriter mechanics, who must therefore be familiar with functions, tests, wiring, and adjustments of all relays, switches, keys, etc., contained in the switchboard. However, if extreme care is taken in handling, packing, transporting, and unpacking the equipment, little repair and maintenance will be necessary aside from regular routine inspections and checks. Always keep the voltage and current within specified limits for each circuit. *Over 90 percent of teletypewriter communication failure is caused by faulty lines and grounds; therefore the closest of attention must be given to the installation of lines and grounds.*

b. All lines of the switchboard are arranged for interconnection and monitoring. Figure 152 is a schematic diagram for Switchboard BD-100. Wiring for each of the 10 lines of the switchboard is shown, but only three lines are illustrated. All line circuits are multiplied (or connected in parallel) to equipment common to all lines, namely the operator's teletypewriter, meter, and power supply terminals.

Therefore, any individual line can be connected to the common equipment for monitoring, measuring line current, etc. The multiple connections are designated on the schematic circuit diagram as through lines 3 to 9 inclusive. (See note 2, fig. 152). Current can be supplied to the line from either the switchboard or the distant station, depending upon the position of the line battery switch. If necessary, line current can be supplied by both stations. The positive (+) battery terminal on the switchboard is normally grounded. All keys, switches, etc., are shown in their normal positions. All have make-before-break (MBB) contact operation except the line battery switches and ANSWER key, which have break-before-make (BBM) contact operation. The floating contact of make-before-break contact assemblies "makes" one circuit before it "breaks" another. The floating contact of break-before-make contact assemblies "breaks" one circuit before "making" another. Break-before-make contact operation is used with the ANSWER keys to prevent the operator from interfering with a conference circuit when an ANSWER key is depressed for monitoring. The same contact operation is used with the line battery switch to avoid short-circuiting the power source when the switch is operated in either direction. Make-before-break contact operation is used on all other keys, switches, etc., to prevent momentary opens from the operation of the floating contact. Compare the schematic diagram (fig. 152) with the actual diagram (fig. 153), which is color-coded for tracing circuits and locating parts. The left side of the actual wiring diagram is of individual line equipment (one line) and the right side is of equipment common to all lines. All lines marked (+) and (-) are actually connected, metallicly, to the positive and negative switchboard battery terminals.

84. Functioning of Parts

The following paragraphs pertain to the sequence of circuit operation of Switchboard BD-100 as power and lines are connected, calls made and answered, and conference connections completed. The meter and miscellaneous circuits are also discussed. The switchboard supplies line current for all lines; all keys, switches, etc., are in their normal positions unless otherwise specified.

85. Local Relay Circuit (fig. 128)

When power connections are made to Switchboard BD-100, current flows through the local relay wind-

ings. This causes the make contact (8) to close and the break contact (3) to open. The circuit goes from positive battery at the upper patching jack through the ANSWER key, contacts (5) and (2) of the line relay, the 3,600-ohm resistor and the windings of the local relay, through a ¼-ampere fuse to negative battery. The line relay armature is not closed because the line circuit is not completed at the switchboard terminals.

86. Signal Lamp Circuit (LINE OPEN Key Out) (fig. 129)

The signal lamp circuit is energized once power is connected to the switchboard and the signal lamp is caused to light. The circuit traces from the positive terminal at the night alarm, through the night alarm switch, the signal lamp, a 2,000-ohm resistor, the LINE OPEN key, and the contact and armature of the signal relay to negative battery. The signal relay armature is in the unoperated position because the circuit through its windings is open under the conditions described.

87. Signal Lamp Circuit (LINE OPEN Key In) (fig. 130)

When power is connected to the switchboard, the signal lamps light, allowing the installer to make a visual check. The installer extinguishes the lamps so that they will give an indication when the signal line is completed. Depressing the LINE OPEN keys will extinguish the lamps. This circuit is traced from positive battery at the night alarm, through the signal lamp, a 2,000-ohm resistor and the open contacts of the LINE OPEN key; thus no current will flow through the signal lamp.

88. Operator's Teletypewriter Holding Circuit (fig. 131)

A third circuit operated when power is connected is the operator's teletypewriter holding circuit. (See fig. 131.) This circuit holds the receiving mechanism of the operator's teletypewriter "closed" when power is applied to the switchboard and no ANSWER key is depressed. This circuit goes from positive battery at the RED MULTIPLE jack, through the ANSWER keys, a retardation coil, the RED OPERATOR'S PRINTER jack sleeve (receive), through the selector magnets, out the RED OPERATOR'S PRINTER jack tip, a retardation coil, a 1,600-ohm resistor, through a ¼-ampere fuse to negative battery. The current is limited to about 60 ma by the

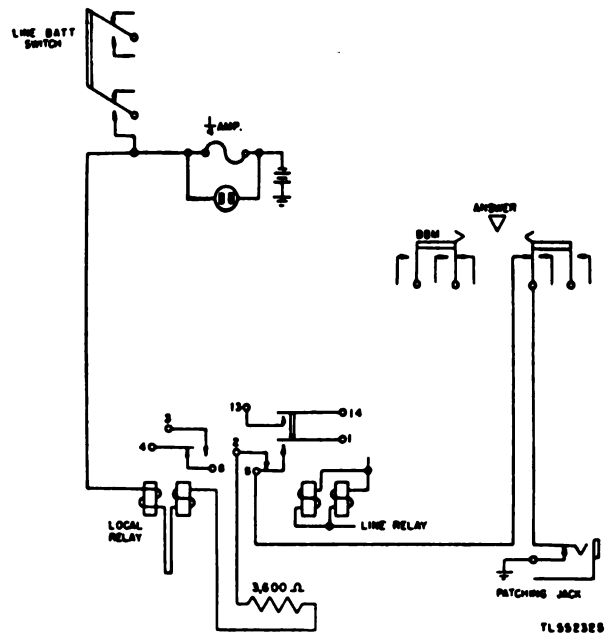

Figure 128. Local relay circuit.

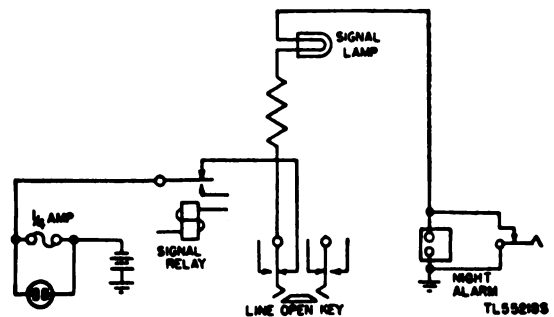

Figure 129. Signal lamp circuit. (LINE OPEN key out).

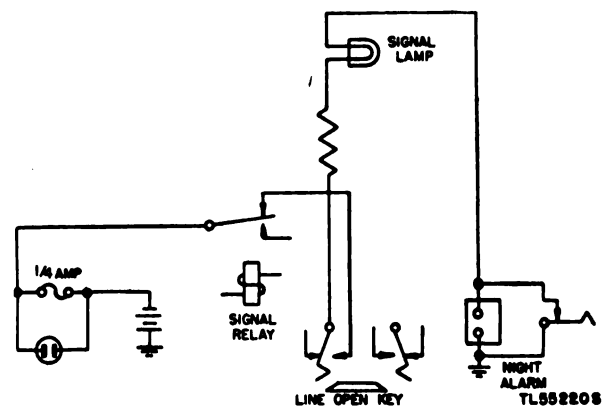

Figure 130. Signal lamp circuit. (LINE OPEN key in).

1,600-ohm resistor plus the resistance of the selector magnet.

89. Line Relay Circuit (fig. 132)

The line relay circuit is completed through the windings of the line relay when the signal line is connected to the switchboard and to a distant station. The circuit can be traced from the switchboard positive battery terminal, through the common ground

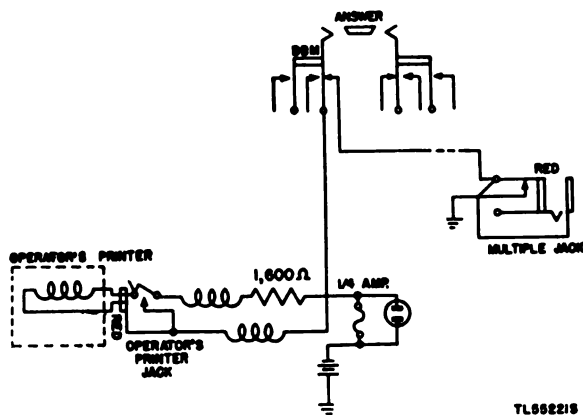

Figure 131. Operators' teletypewriter holding circuit.

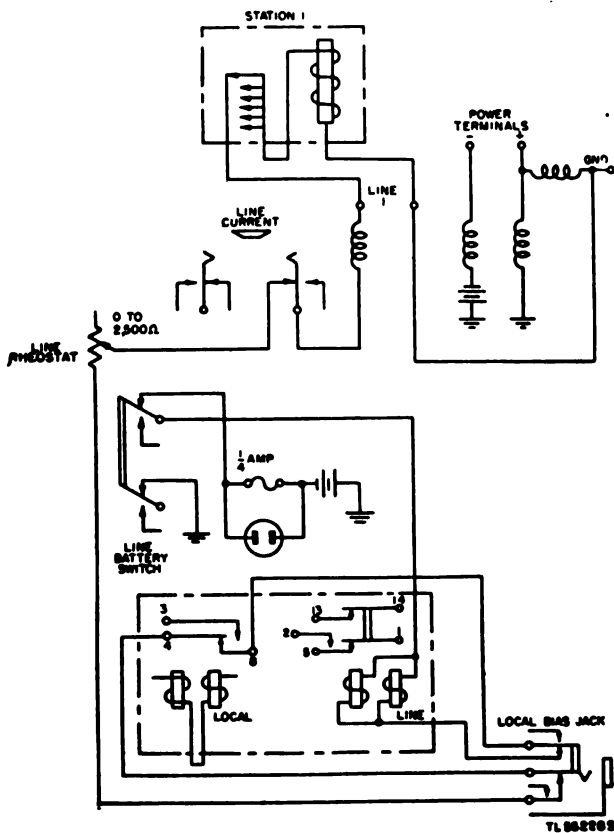

Figure 132. Line relay circuit.

terminal and out to the distant station equipment, back to the switchboard line terminal and through the unoperated LINE CURRENT key, the rheostat, local BIAS jack, local relay armature, LOCAL BIAS jack again, and through the line relay windings and the line battery switch to negative battery. Completion of this circuit operates the line relay, causing the armature to make contact with the lower (5) and the upper (13) contacts and break the center one (2).

90. Signal Relay Circuit

When the armature of the line relay closes, the upper (13) contact is made. (See fig. 133, solid lines.) The upper contact (13) of the line relay is grounded to the relay frame as is a lead from the positive battery terminal. The relay frame is insulated from the switchboard frame. Positive battery is supplied to the signal relay circuit through the ground of the upper (13) contact. The circuit continues through the line relay float (contact (14)), signal relay windings, and the LINE OPEN key (depressed), through the signal relay contact and armature to negative battery. The armature of the signal relay is caused to make with its lower contact, thereby completing a circuit through the operated LINE OPEN key, and through the signal lamp. (See broken lines in fig. 134.) The lamp then lights, indicating a completed line. The lamp is extinguished by depressing the ANSWER key. This opens the circuit to the signal lamp at the LINE OPEN key. The LINE OPEN key is mechanically operated by the ANSWER key so that

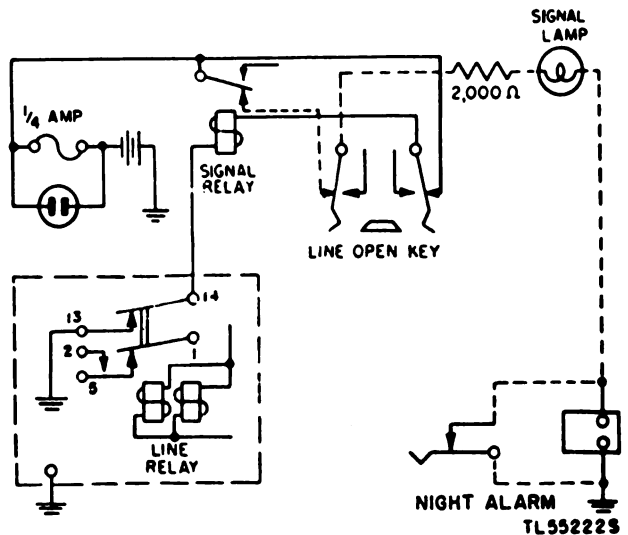

Figure 133. Signal relay circuit.
LINE OPEN key operated.

it is returned to its unoperated status when the ANSWER key is depressed. This opens the circuit to the signal lamp at the LINE OPEN key. When the armature of the signal relay closes, it also completes another circuit through its own winding when the LINE OPEN key is in its unoperated position. (See fig. 134.) Because the LINE OPEN key has make-before-break contacts, this circuit through the winding will be completed before the other is opened. The lamp circuit, however, is kept opened by the LINE OPEN key.

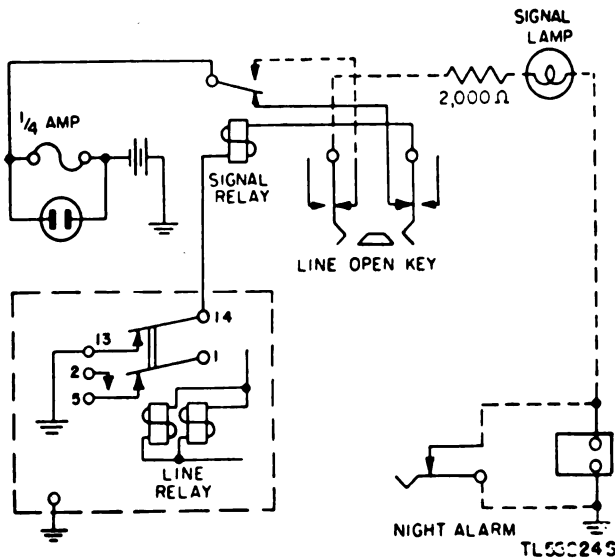

Figure 134. Signal relay circuit. LINE OPEN key unoperated.

91. Signaling the Operator

After all lines on Switchboard BD-100 are lined up, operating personnel take over the switchboard. When a substation operator wishes to signal the switchboard operator, the substation operator depresses his break key for approximately 3 seconds. The resulting break signal (no current) causes the line relay armature to be pulled away from the core of the relay by its biasing spring. This breaks the two contacts (13) and (14). (See fig. 135.) This depresses the signal relay, releasing its armature, breaking the bottom contact and making the top one, and completing the signal lamp circuit. (See broken lines, fig. 135.) When the break key at the substation is restored to its normal position, the line relay of Switchboard BD-100 again operates and ground (positive battery) is restored on the upper armature (line relay). The signal relay circuit remains open, however, because the signal relay is in its upper position. Thus the signal lamp remains lighted until another circuit is provided for the

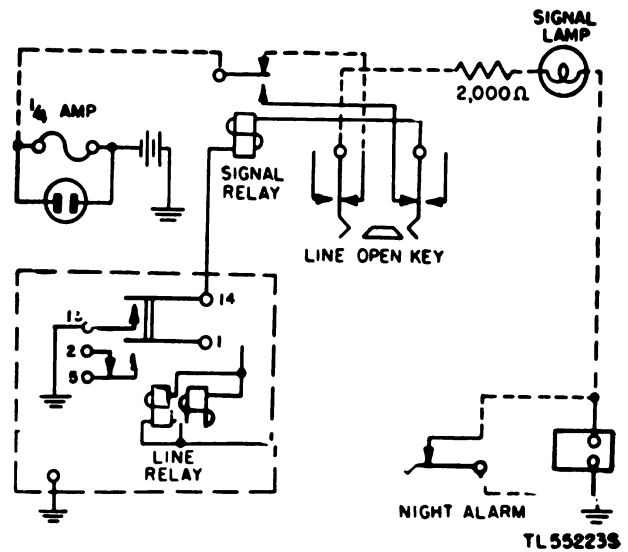

Figure 135. Signal relay circuit when operator is signaled.

signal relay. Because the signal relay is slow-acting, it will not react when ground is removed at the line relay armature by a normal spacing impulse.

92. Answering an Incoming Call

a. When the switchboard operator observes a lighted signal lamp, he depresses the ANSWER key of that particular line. This extinguishes the lamp by closing the armature of the signal lamp. The ANSWER key provides a shunt around the signal relay armature, completing the signal relay circuit. (See fig. 136.) This circuit traces from ground (positive battery) through the line relay armature, the signal relay winding, the LINE OPEN key, and the ANSWER key to negative battery. In closing, the signal relay armature breaks the lamp circuit and closes another circuit through the winding of the signal relay. (See fig. 134.) This circuit will hold the signal relay operated when the ANSWER key is restored to its normal position.

b. Depressing the ANSWER key also places the operator's teletypewriter in that particular line circuit. (See fig. 137.) This circuit may be traced from positive battery at the upper patching jack through the ANSWER key, retardation coil, the operator's transmitter contacts, a retardation coil, and the make contact and armature of the line relay and the lower patching jack. At the lower patching jack, there is a division of the circuit. One side goes up through the ANSWER key and through the sleeve of the receiver jack and the selector magnet of the operator's teletypewriter, the tip of the receive jack, a retardation coil, and a 1,600-ohm resistor to negative

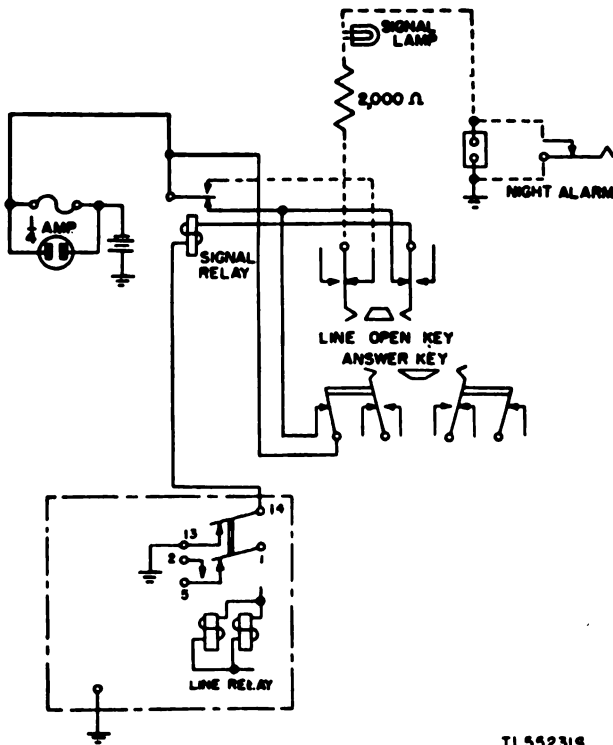

Figure 136. Signal relay circuit when incoming call is answered.

battery. The other half goes through the 1,600- and 2,000-ohm resistors and local relay windings to negative battery. Figure 138 is a simplified diagram of these circuits.

c. The operator's teletypewriter selector magnet and the windings of the local relay are wired in parallel to each other from negative battery but are connected in series with two sets of contacts and positive battery. The transmitting contacts send to both the switchboard local relay and the selector magnets of the operator's teletypewriter. Thus home copy is obtained and at the same time the message is sent to the distant station by making and breaking the local relay armature which is in series with the substation equipment. The distant station can send to the operator's teletypewriter by operating the line relay armature which is in series with both the local relay windings and the selector magnets of the machine. The local relay is not affected by the operation of the line relay armature because a holding circuit (dotted lines, figs. 137 and 138) is used. This keeps the local relay operated. This circuit is completed by action of the make-before-break contacts of the line relay armature and holds the local relay operated when a spacing impulse is received by the line relay. When the make-before-break con-

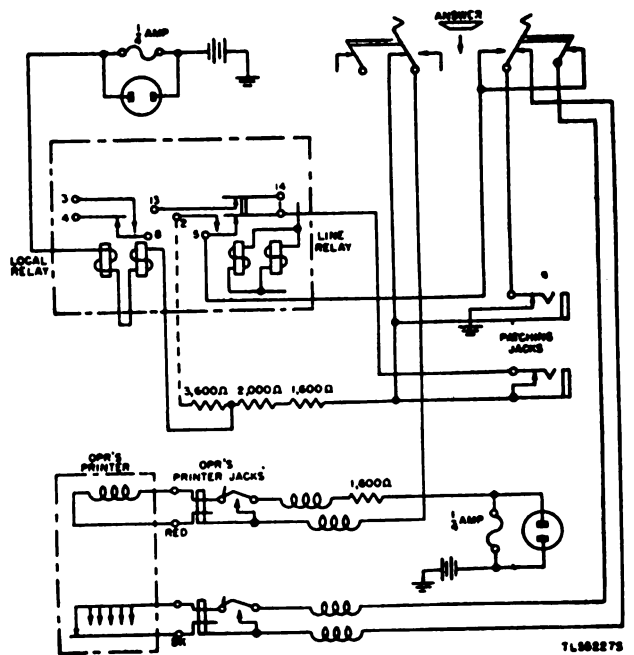

Figure 137. Operators' teletypewriter circuit, with operators' teletypewriter placed in circuit.

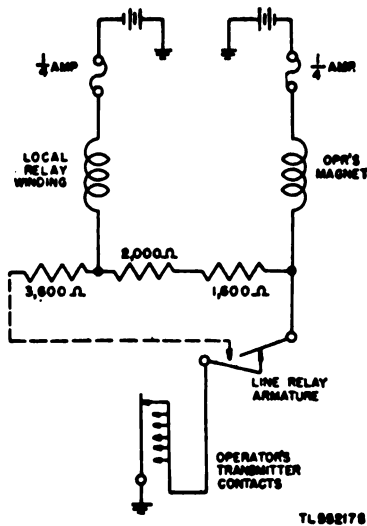

Figure 138. Operators' teletypewriter circuit, simplified diagram.

tacts of the line relay operate, a circuit is completed through the three resistors and the operator's teletypewriter selector magnets. However, there is only $1\frac{1}{2}$ ma of current flowing in this circuit and it will not noticeably affect the operation of the machine.

93. Station-to-station Connection

a. After the calling station operator has contacted the switchboard operator and requested connection

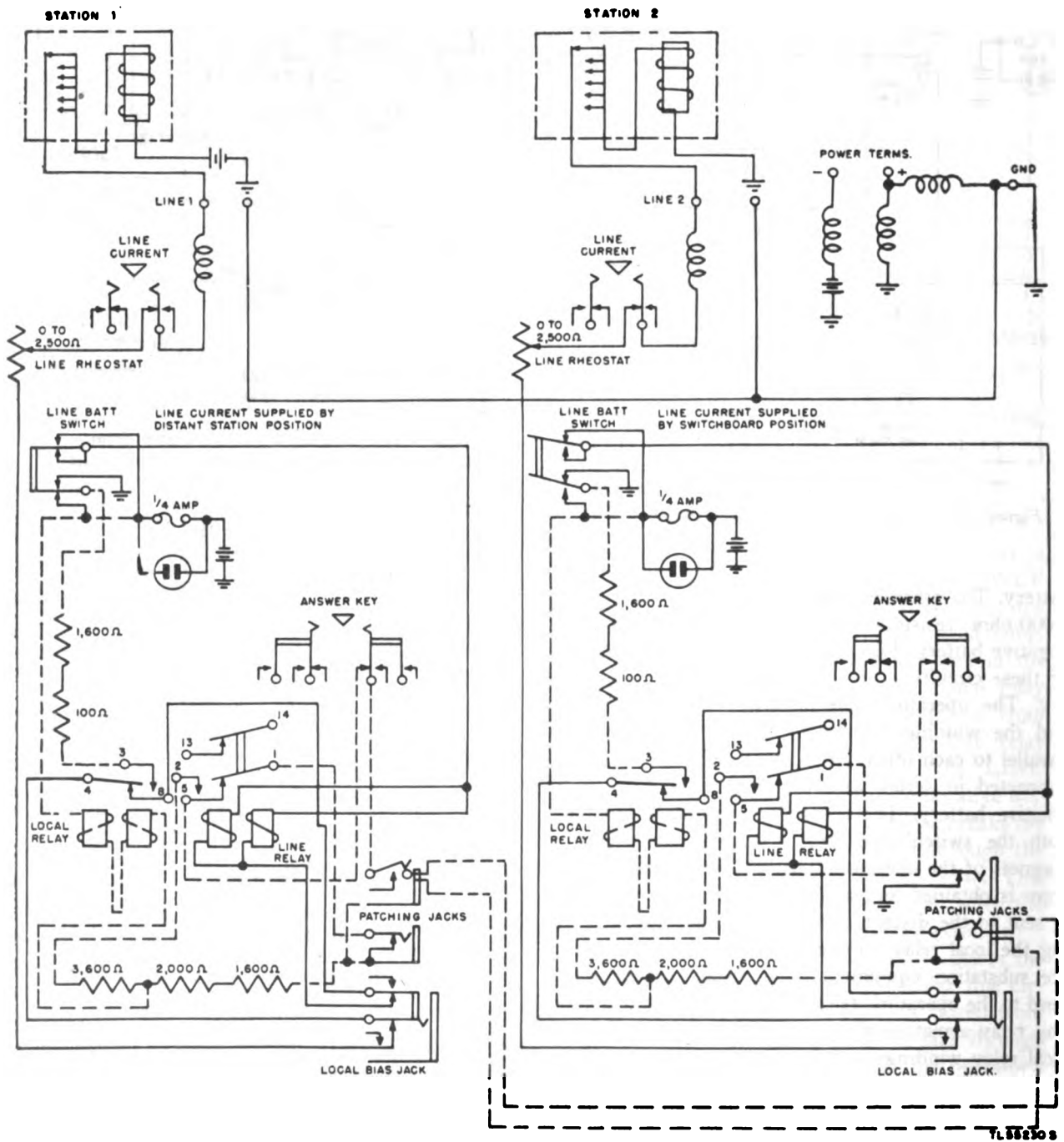

Figure 139. Station-to-station connection.

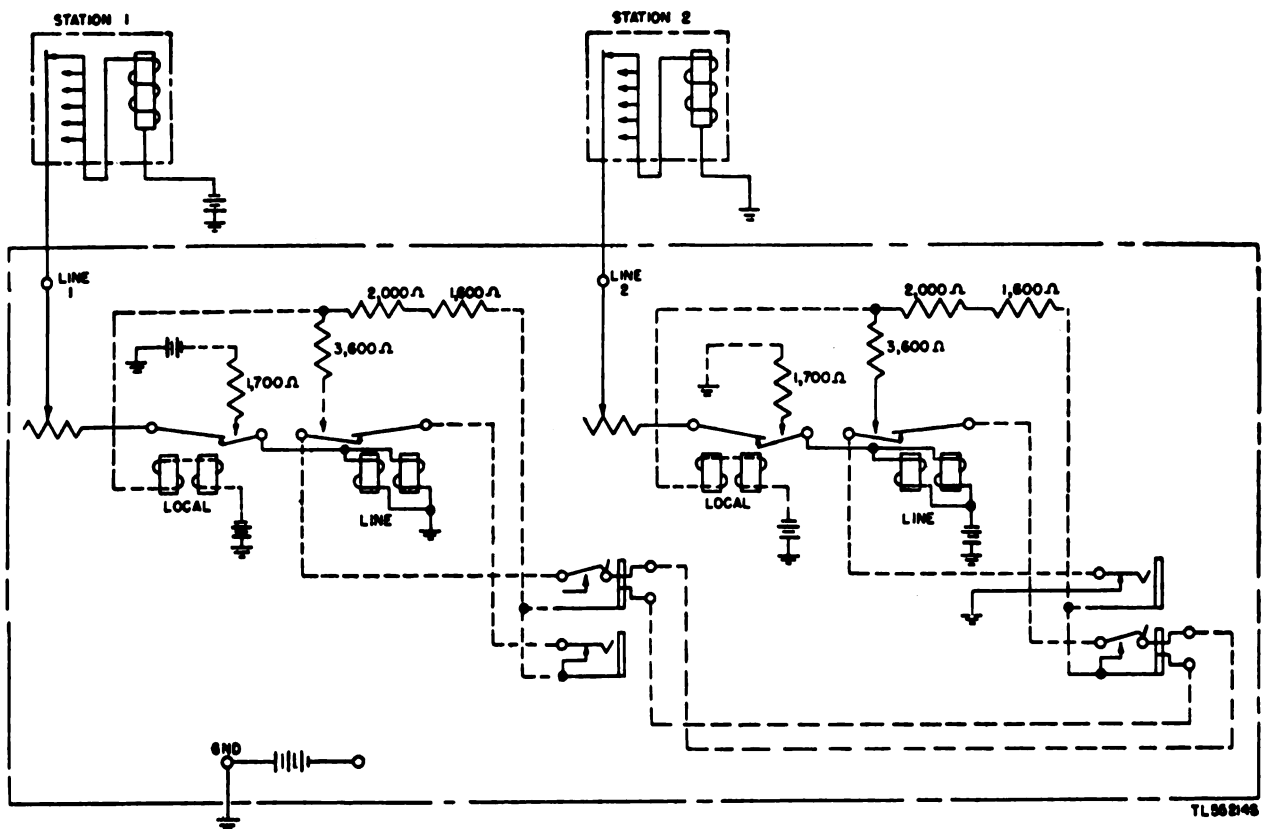

Figure 140. Station-to-station connection, simplified diagram.

to another substation, the switchboard operator connects them by patching the lower line jack of the called station to the upper jack of the calling station. This connects the relays of the two lines as shown in figure 139. A simplified diagram is shown in figure 140.

b. When signals are transmitted from one station, its line relay repeats the signals to the local relay of the other station. The local relay in turn repeats them over the line to the receiving station. The local relay holding circuit keeps the local relay of the sending station from releasing its armature. Another similar holding circuit is used to hold the line relay of the receiving station closed when the local relay is repeating a spacing impulse to the substation. Both holding circuits are shown by dotted lines in figures 139 and 140. When the line current is supplied from the distant station, the positive terminal should be grounded at the distant station. In the switchboard, when the battery switch is operated to **LINE CURRENT SUPPLIED BY DISTANT STATION**, negative battery is removed from the line circuit (fig. 139), and ground at the positive battery terminal is supplied to the windings

of the line relay. At the same time negative battery is supplied to the 1,700-ohm resistor (shown on fig. 139 as 1,600 ohms and 100 ohms) connected to the make-before-break contact of the local relay. This circuit keeps the line relay operated when the local relay releases.

c. Figure 140 shows two stations connected by means of a patching cord. The left portion of the diagram represents station 1 equipment, and the right portion represents station 2 equipment. The diagram shows station 1 supplying current for its own line to the switchboard; line current for station 2 is supplied by the switchboard. This type of connection is selected to show the operation of each type of line circuit. When transmitting station 1 operates its switchboard line relay. This circuit in figure 140 is traced from negative battery to station 1 equipment through the line, the line rheostat, the armature, and the make contact of the operated local relay, and through the windings of the line relay to the grounded positive battery terminal. The circuit is completed to positive battery at station 1 through the earth. Impulses through the windings of the line relay cause its armature to make and break the

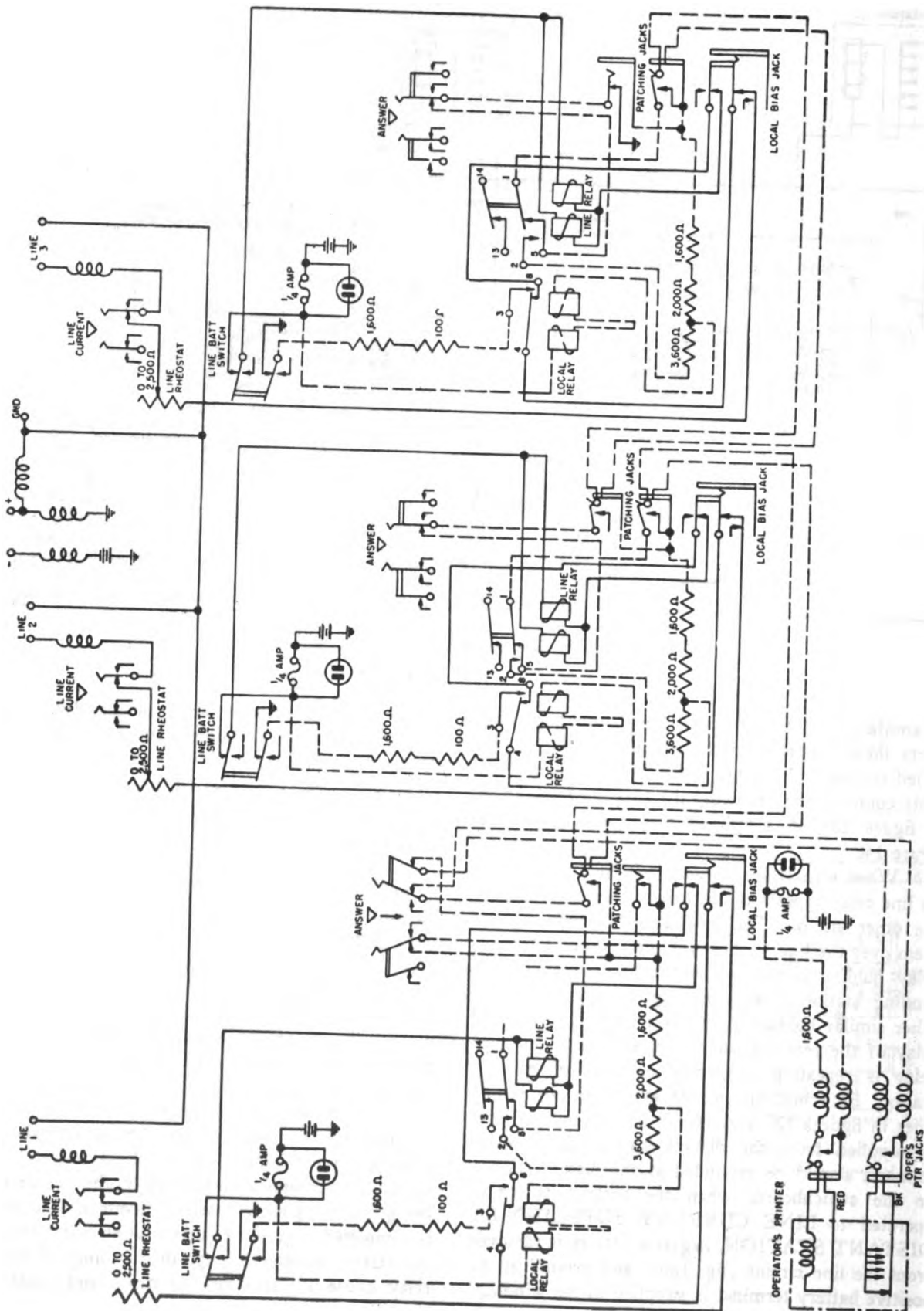

Figure 141. Three-party conference with operators' teletypewriter.

7190228

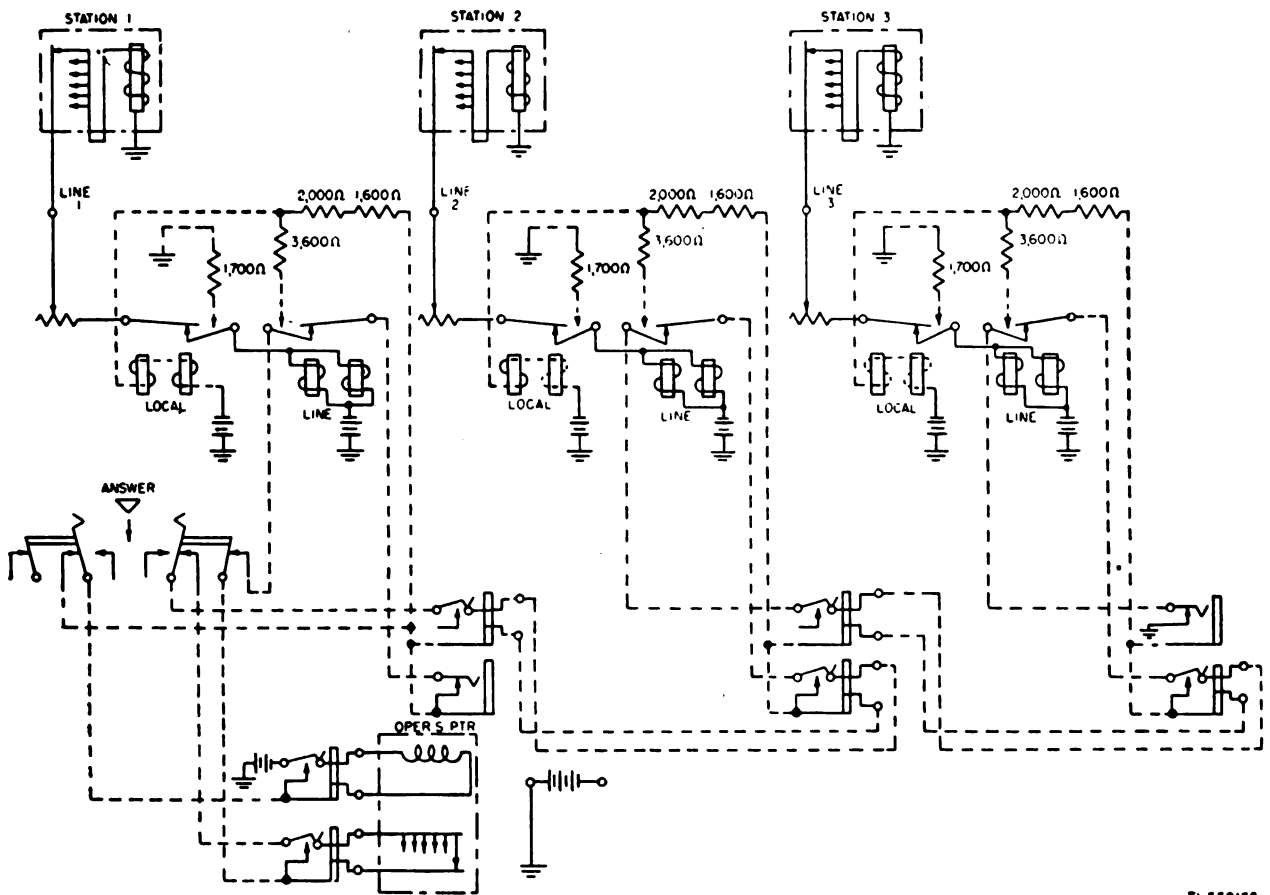

Figure 142. Three-party conference with operators' teletypewriter, simplified diagram.

TL 552165

circuit to the local relay of line 2. The circuit for this operation (broken lines) is from negative battery at the local relay of line 2 through the windings of the relay, the 2,000-ohm and the 1,600-ohm resistors, the sleeves of the lower patching jack, the patching cord and the upper patching jack, the armature and the make contact of the station 1 line relay, and the armature and the make contact of the station 2 line relay to positive battery. The impulses that are repeated through the windings of this local relay cause the armature to make and break the circuit of line 2 and repeat the signals to that station's equipment. When station 2 transmits, the operation is the same as for station 1 transmitting excepting that the relay operation is in reverse order; that is, the line relay of station 2 repeats the signals to the local relay of station 1. The circuit of line 2 differs somewhat from that of line 1. (See fig. 140.) It goes from negative battery at the line relay through the windings, make contact, and armature of the local relay, through the line rheostat, line, and substation equipment to ground.

94. Three-party Conference with Operator's Teletypewriter

a. The station calling the switchboard may wish a conference with more than one other station. (See fig. 141.) Figure 141 is a schematic of three lines patched together with the operator's teletypewriter included in the conference. Figure 142 is a simplified diagram of these same circuits. When a station transmits, its line relay operates the same as in the station-to-station connection; and the operation of the line relay causes the local relays of all the other lines to operate, repeating the impulses to their respective stations. Impulses sent by station 1 operate the line relay by breaking and making the line circuit. The operation of this relay repeats the signals to the operator's teletypewriter magnet and windings of the local relays of all other lines. This circuit is shown in broken lines in figures 141 and 142. In figure 142 it can be traced from positive battery at the upper patching jack of line 3 (no cord inserted) through the armature and make contact of the line relay of station 3. From here, it follows over the

tip of the patching cord, through the make contact and the armature of the line relay of station 2, over the tip of the other patching cord, to the ANSWER key. From here it passes through the transmitting contacts of the operator's teletypewriter, back through the ANSWER key, the make contact and armature of the station 1 line relay, and the lower patching jack of station 1 (no cord inserted), to the sleeve of the upper patching jack. At this jack sleeve, the circuit divides. One circuit is through the ANSWER key and selector magnet of the operator's teletypewriter to negative battery. This circuit permits the operator's teletypewriter to receive signals sent from station 1.

b. Another circuit exists from the sleeve of the upper patching jack up through the 1,600- and 2,000-ohm resistors and local relay winding of line 1 to negative battery. This relay will not react to the impulses repeated by the line relay because the make-before-break contacts of the line relay close the local relay holding circuit.

c. A third circuit traces from the lower patching jack of line 1 through the sleeve of the patching cord and the sleeve of the lower patching jack of line 2 to the sleeve of the upper jack. Here, this circuit divides. One circuit goes through the 1,600- and 2,000-ohm resistors and the local relay windings to negative battery. This circuit causes the local relay of line 2 to repeat the signals to the station. The other circuit is through the sleeve of the other patching cord, the sleeve of the lower patching jack of line 3, the 1,600- and 2,000-ohm resistors, and the windings of line 3 local relay to negative battery. This circuit operates the line 3 relay which repeats the signals to that station.

d. Impulses from station 2 or station 3 will cause the same operation except that the line relay of the sending station operates, repeating the signals to local relays at the other lines and the operator's teletypewriter magnets. The operation of a three-party conference is best illustrated in figure 143. This figure shows all line relay armatures and transmitting contacts of the operator's teletypewriter in series with the lead to positive battery. It is apparent that the opening of any line relay armature, or the transmitting contacts of the operator's teletypewriter, will break the circuit to all local relays and the selector magnet. It is also evident that a hold circuit (shown by broken lines) is inserted for the local relay of the line relay that is operated. No holding circuit is involved with the operator's transmitting contacts since all local relays operate when the

switchboard operator sends to three stations. Copy for the monitoring printer is obtained by the operation of any line relay or the transmitting contacts.

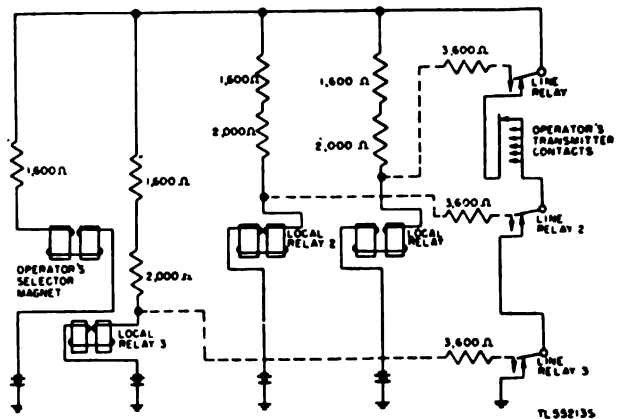

Figure 143. Three-party conference with operators' teletypewriter, showing all line relay armatures and transmitting contacts of the operators' teletypewriter in series with lead to positive battery.

95. Voltage Measurement Circuit

Internal circuits of Switchboard BD-100 are designed to operate with maximum efficiency on 115 volts (direct current). For proper operation of the switchboard circuits this voltage must be maintained. The voltmeter mounted on the switchboard provides the attendant an accurate means of checking the voltage. The meter is arranged to indicate voltage when the meter-switching key is in its normal (center) position. The circuit goes from positive battery through the contacts of the meter-switching key, the meter, and other contacts of the key, through the 150,000-ohm resistor to negative battery. The 150,000-ohm resistor limits the current flow in the circuit to an amount that will cause the meter needle to

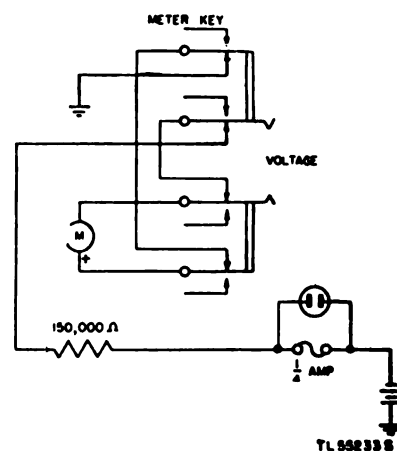

Figure 144. Voltage measurement circuit.

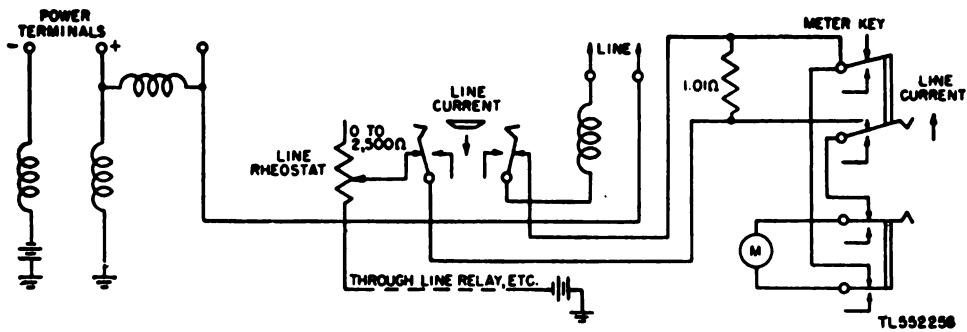

Figure 145. Line current measuring circuit.

indicate 115 (center red mark of the three red marks on the meter scale) when 115 volts is applied to the circuit.

96. Line Current Measurement Circuit

To measure the line current, the voltmeter, with a 1.01-ohm shunt resistor across its terminals, is inserted in series with the line circuit. The line current measuring circuit shown in figure 145 is made operative by depressing the line current key and operating the meter-switching key to the LINE CURRENT position. The circuit may be traced from positive battery at the switchboard terminals through the line, substation equipment, and the LINE CURRENT key to the 1.01-ohm shunt resistor. Here the circuit divides. One side conducts 99 percent of the current through the shunt, while the other side conducts 1 percent of the current through the meter key, the meter, and again through the meter key to the other side of the shunt. Here the two sides join, continuing through the LINE CURRENT key, line rheostat, line relay, etc., to negative battery. Only 1 percent of the line current will flow through the meter because of the low resistance of the 1.01-ohm shunt. However, the meter is calibrated to indicate the full amount of line current. For example, if 100 ma of current is flowing in the line, 99 ma will go through the shunt and 1 ma will flow through the meter. This 1 ma is enough to cause the meter needle to indicate 100 ma on the meter scale.

97. Bias Measurement Circuit

a. To check bias on Switchboard BD-100, the relay contacts must be patched, to be tested, into the bias meter circuit, and the meter-switching key must be placed at the BIAS (down) position. When the meter-switching key is placed at BIAS, a local circuit is arranged as a bias measurement circuit (fig. 146) in which the meter is connected. This

circuit, with local relay contacts under test, is shown in simplified form in figure 147. The circuit is designed so that when the relay contacts apply repeated space signals with current impulses of standard length to the lower branch of the circuit, the meter indicates zero bias.

b. The circuit is balanced when the average current through the lower branch equals the steady current through the upper branch. When the relay contacts are open or closed (fig. 147), a circuit exists which starts from negative battery and divides at the 5,000-ohm resistors. One side goes through the 5,000- and 10,000-ohm resistors to positive battery. The other side of the circuit exists from the other 5,000-ohm resistor, through the 15,000-ohm resistor, the meter (– to + terminals) and the 10,000-ohm resistor, to positive battery. The current flow through the meter is in the direction which will cause the meter needle to move to the left. When the relay contacts are closed (marking impulse), another path to positive battery is provided, forming two other circuits. One goes from negative battery through the upper 5,000-ohm resistor, down through the meter (+ to – terminals), the 15,000-ohm resistor, the 400-ohm resistor, the 0-400-ohm rheostat, and the relay contacts to positive battery.

c. The other circuit is from negative battery through the 5,000- and 400-ohm resistors, the rheostat, and the relay contacts to positive battery. The current that flows through the meter is in the direction (+ to – terminals) that will cause the meter needle to move to the right of zero and is of greater magnitude than the current flowing through the meter in the opposite direction. Therefore, when zero bias is present in signals repeated by the relay, the alternation of current through the meter causes the meter needle to oscillate at zero. If the relay contacts remained closed longer (marking

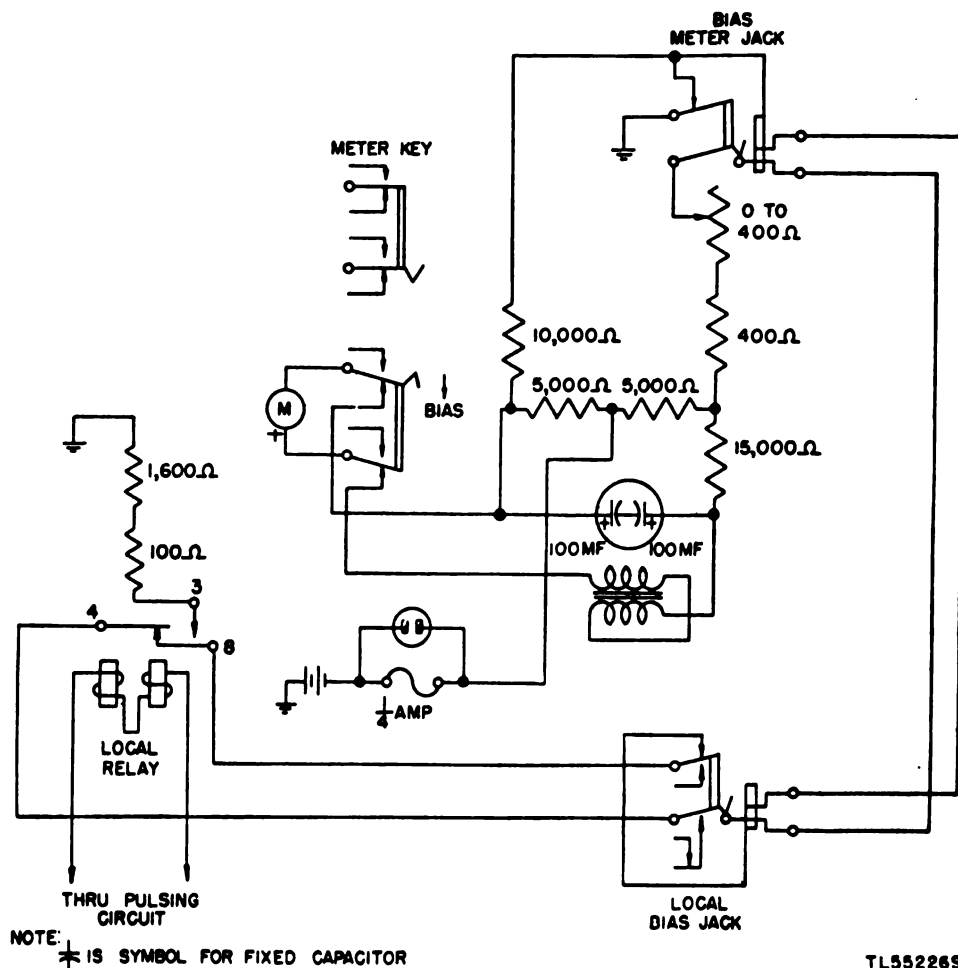

Figure 146. Bias measurement circuit.

bias), the current flow through the meter in one direction (+ to - terminals) will average a greater amount than the current in the opposite direction. This causes the meter needle to oscillate at some point to the right of zero, indicating the marking bias. The opposite is true if the relay contacts remain closed for a short period of time (spacing bias). The 15,000-ohm resistor in series with the meter protects the meter from overload; the transformers and capacitors (fig. 146) provide for steadier meter reading by damping the meter needle. While the local relay is biased, there must be provided a means of keeping the line circuit closed so that the substation will not be affected by signals sent from the local relay. This is done by the bottom pair of contacts of the local bias jack that close when a plug is inserted into that jack. When the line relay is biased, the circuit is essentially the same. The contacts of the line relay are put in the circuit by patching from the bias meter jack to

the lower patching jack. A circuit permitting the operator's teletypewriter to run closed while the line relay is provided through sleeves of the lower patching jack, patching cord, and bias meter.

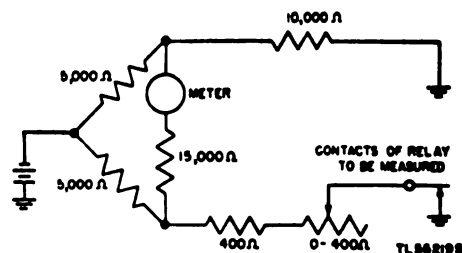

Figure 147. Bias measurement circuit, simplified diagram.

98. Service and Repair

Service and repair of Switchboard BD-100 consists mainly of an occasional adjustment of repeater Relay BK-27-A, signal relays, and keystrips; the test and replacement of switchboard lamps, fuses, and blown-fuse indicators; and the cleaning of all

jacks and plugs. If repeater Relay BK-27-A fails to function properly, replace it with one from Chest CH-70 and adjust the discarded one as soon as possible. Chest CH-70 (fig. 148) is supplied with each Switchboard BD-100. It is used for packing tools, accessories, and running spare parts including such items as lamp and cap extractors, screw drivers, fuses, lamps, lamp caps, 72-inch cords for multiple installations, etc.

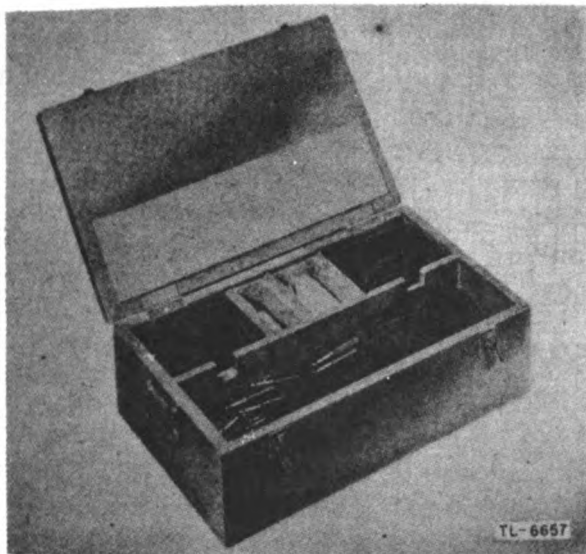

Figure 148. Chest CH-70.

a. **RELAY BK-27-A.** This relay consists of two individual relays mounted on a common base and covered completely with a metal cover. Figure 149 shows one of these relays. The unit is jack-mounted in the switchboard for convenience in making replacements but should not be removed unless it is absolutely necessary for checking or adjusting. A wiring diagram of repeater Relay BK-27-A is shown in figure 150. The local relay circuit is shown in heavy lines with terminal No. 12 supplying positive battery and No. 7 giving negative battery. Terminals No. 10 and 11 are strapped at their jacks to connect the two windings in series, allowing the full amount of current flowing in the circuit (approximately 30 ma) to flow through both windings. Broken lines show the line relay circuit with terminals No. 9 and 6 furnishing positive and negative battery. Unlike the local relay, the line relay windings are connected in parallel. This causes the 60 ma of line current to divide, allowing 30 ma to flow in each winding. The lower make contacts are grounded to their relay frames as are

terminals 13 and 15. The local and line relays are insulated from each other as well as from the switchboard.

b. **SIGNAL RELAYS.** Some circuits require a relay to be slow to operate, slow to release, or both. Usually these relays are used to obtain a certain sequence of operation in a circuit, or to obtain a time interval in the circuit operation. One method used in the design of slow-acting relays is the placing of a very thick copper sleeve or slug around the core. This type of relay (fig. 151) is used in Switchboard BD-100 for signal relays to keep the signal lamp circuit from reacting to normal spacing impulses. They should be removed and adjusted only when absolutely necessary.

c. **KEYSTRIPS.** Keystrips seldom require removal or adjustment although some troubles are likely to occur, such as dirty, burned, or maladjusted contacts. Keystrips have flexible contact springs that are constructed and adjusted so that movement of the floating contact spring, which causes the contacts to close, is continued for a short distance after the contact is made. The continued movement, called contact follow, causes a wiping action between the contacts which tends to make them self-cleaning. To reduce further the chance of trouble from dirty contacts, the springs are split and a contact placed on each half. This enables the contact spring to function normally even if one pair of contacts becomes dirty. If cleaning becomes necessary, use only carbon tetrachloride. Great care must be taken in cleaning because these contacts are made of very soft metal. When the contacts are badly burned, replace the springs. If spare contact springs are not available, it may be possible to substitute unused contact springs from other key assemblies, such as LINE CURRENT keys which have one unused spring. Maladjustment of contact springs is the usual cause of most trouble. If the springs are incorrectly adjusted, the wiping action may not be present and dirty contacts will be the result. Incorrect adjustment may also cause arcing at the contacts, which causes them to burn. Adjustment of keystrips must be done strictly according to the specifications given in the manuals accompanying each switchboard.

d. **BLOWN-FUSE INDICATORS.** The blown-fuse indicators in Switchboard BD-100 and Line Unit BE-77-A are identical, and their functions are alike. When a fuse is blown, the line voltage is applied to the neon bulb and makes it glow. Spare blown-fuse indicators are included in Chest CH-70.

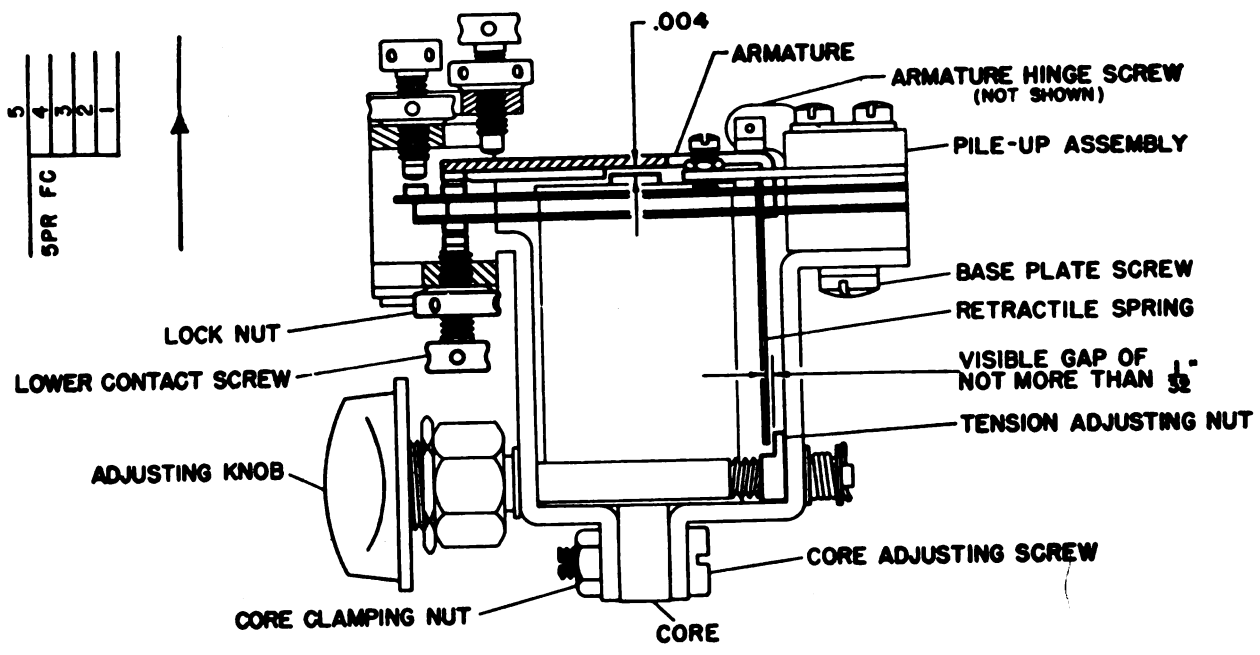

RELAY OPERATED

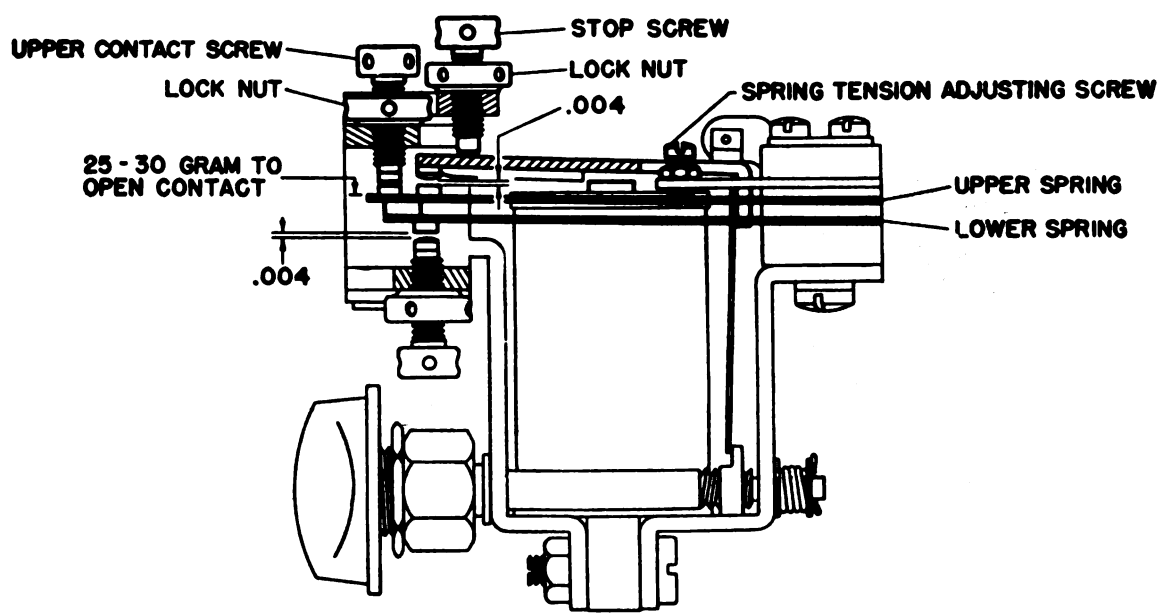

RELAY NON-OPERATED

Figure 149. Relay BK-27-A, adjustment drawing.

c. **PATCHING CORDS.** To maintain high-grade transmission through the patching cords, keep all plugs as clean as possible. A light oil and a cake rouge or a paste-type metal polish may be used to maintain brightness. The use of light oil and cake rouge is recommended because there is less tendency to use an unusually large amount of polishing

material. It is also easier to remove an unused portion of the polishing material from the plug after the operation is completed. When either cake rouge or paste-type polish is used, all surplus polishing material must be thoroughly removed from the plug before the plug is again used.

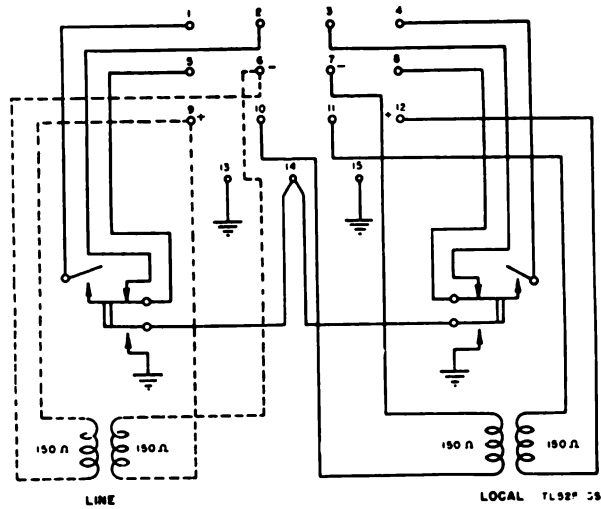

Figure 150. Relay BK-27-(A),

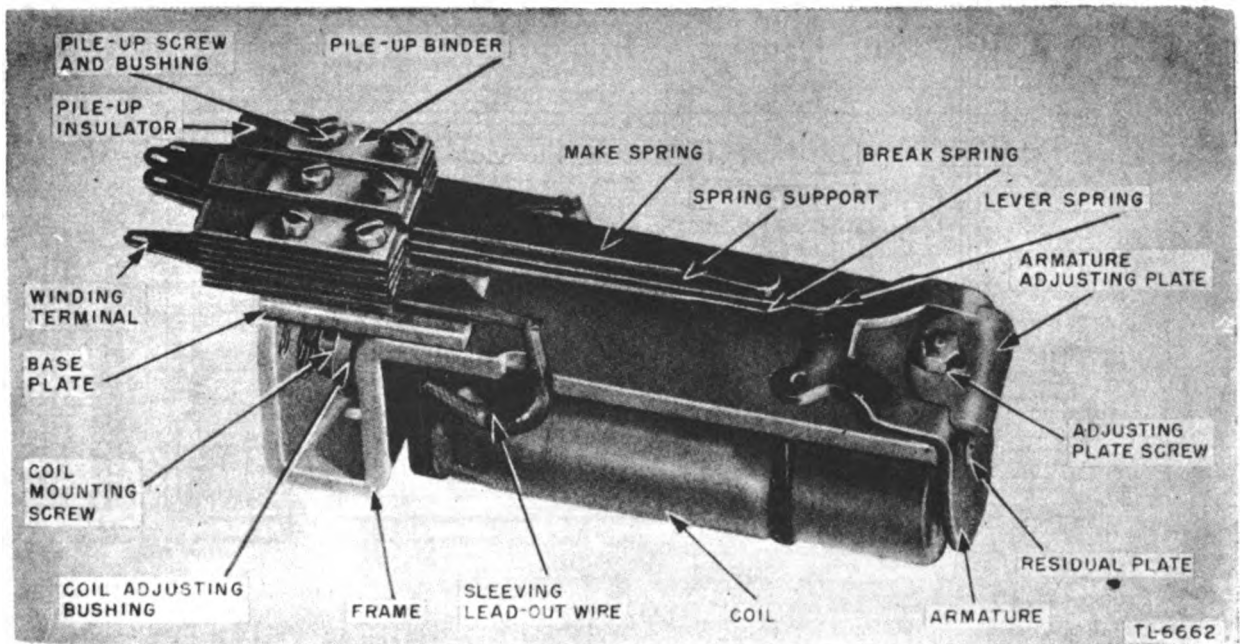

Figure 151. Slow-acting signal relay.

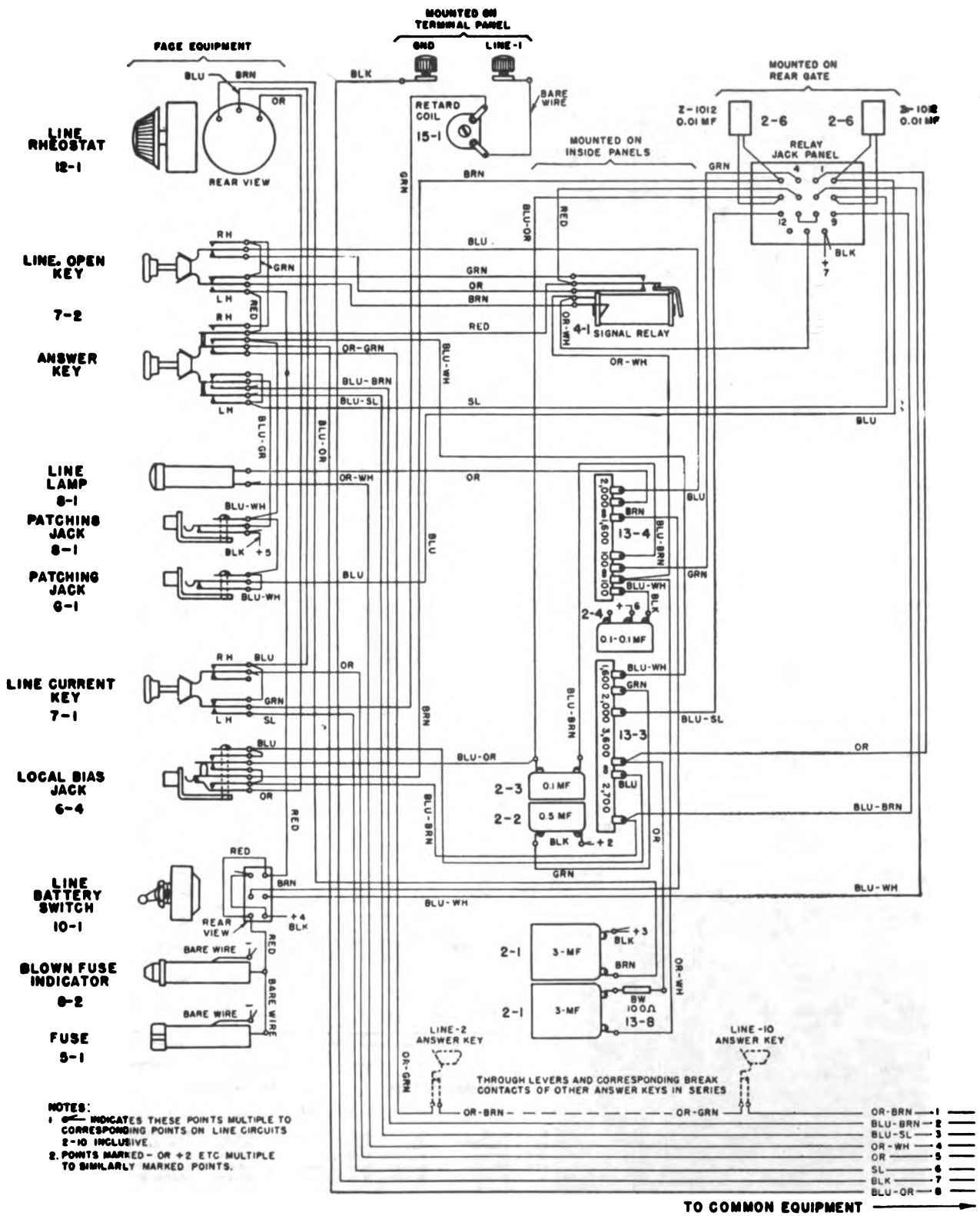

Figure 153. Switchboard BD-100, wiring diagram.

Section V. INTEROPERATION AND CONNECTION OF TELETYPEWRITER EQUIPMENT IN CON- JUNCTION WITH D-C REPEATERS

99. Introduction

Where it is necessary to operate teletypewriters over longer distances than is possible with regular neutral operation, some type of repeaters are used at the line terminals, making it possible to use some form of polar signals on the line. These repeaters change neutral signals sent from teletypewriter equipment into polar signals for transmission over the line. They receive polar signals from the line and retransmit them, in neutral form, to the teletypewriter equipment. For this reason, there must be a repeater at each end of the line. An intermediate repeater may or may not be located between line terminals, depending upon the length of the line. The operating range for terminal repeaters covered in this section is approximately 50 miles using field Wire W-110-B simplex. The distance may be greatly lengthened by adding intermediate or regenerative repeaters between the two terminals. The operating range may also be increased by using differently constructed lines such as open wire which will allow up to 200 miles between repeaters. The loop side of the repeater (to teletypewriter equipment) may be as long as 4 or 5 miles using Wire W-110-B simplex. Maintenance, other than first and second echelon, is not performed by the teletypewriter mechanic and, therefore, is not covered in this text.

100. Repeater TG-30 (Terminal, Telegraph)

Repeater TG-30 (Terminal, Telegraph) is a d-c telegraph repeater designed for transmitting to, and receiving from, another repeater at a distant terminal on a half-duplex basis, either with or without an intermediate repeater. It may be used on 66 words-per-minute operation as well as 60, allowing it to be used in conjunction with American and British printing equipment. The repeater is designed for operation on field wire line circuits (simplex) or open wire circuits with ground return. It contains a built-in rectifier. A manual telegraph set incorporated as part of the repeater equipment is used when monitoring printer equipment is not available. The loop or local side of the repeater is arranged for operation on 30- or 60-ma neutral circuits. The line side is arranged for either polar

polar) or two-path polar (full-duplex polar) form of transmission.

a. CONSTRUCTION. The repeater is portable and is housed in a durable wooden carrying case (fig. 154) which completely incloses all equipment while it is in transit. The apparatus comprising the circuits is assembled on mounting plates and panels attached to a framework that is supported on shockproof mountings. Connecting terminals, jacks, switches, potentiometers, fuses (with spares), and the meter required for setting up and operating the repeater are conveniently assembled and clearly designated on the face of the equipment. The repeater with carrying case open and ready for service is shown in figure 155. It is equipped with a receptacle and jacks for connecting the telephone receiver used with manual telegraph operation, and a jack that supplies power for operating a relay test set. The repeater uses three polar relays of the same type. One spare polar relay is located in the compartment which houses the other relays. Storage space is located inside the case for additional spare fuses, spare neon lamps, and technical manuals. A summary of operating instructions is attached inside the cover. The telephone receiver, with its cord and plug, is held by a clamp on the side of the unit when it is not in use. Line protectors, with spares, are located inside the unit.

b. POWER REQUIREMENTS. The repeater circuits require ungrounded 115 volts of direct current. The primary source of power may be alternating or direct current as a selenium-type rectifier is incor-

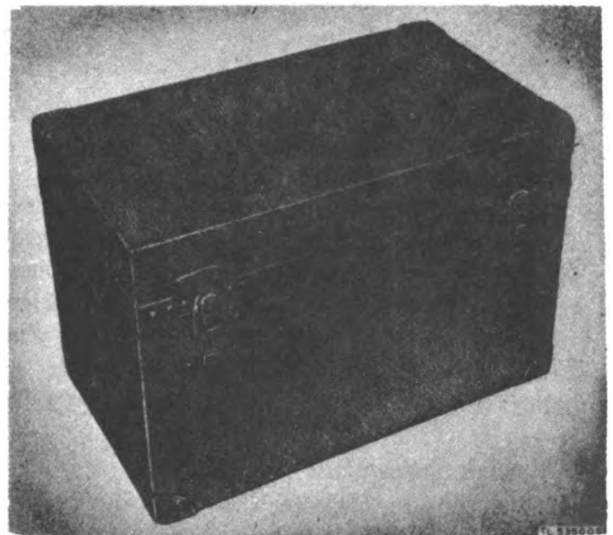

Figure 154. Repeater TG-30 (Terminal, Telegraph) ready for transit.

porated. The rectifier may be operated from 95–125 or 190–250 volts 50–60 cycles alternating current and has a 115-volt tap for furnishing power to the printer motor. It is also equipped with fine and coarse taps for regulating the output voltage. The correct output voltage can be maintained by operation of switches that are associated with the fine and coarse taps. A 10-foot flexible cord is connected to the repeater for connection to the primary power supply. A master power switch is supplied to arrange the repeater for either alternating or direct current. When operation is on 115 volts of direct current, the supply must be nongrounded and the voltage regulated externally. The rectifier output circuit is protected by a ½-amp fuse and the input circuit by a 5-amp fuse.



Figure 155. Repeater TG-30 (Terminal, Telegraph) ready for operation.

c. MONITORING TELETYPEWRITER. Normally, a monitoring teletypewriter is used with Repeater TG-30 for communicating with other stations as well as for monitoring the circuits. Jacks for connection of the printer unit, send and receive plugs, and a receptacle for connection of the printer unit motor are conveniently located on the repeater face.

101. Line Transmission Features

The line side of Repeater TG-30 is designed for either polarential or two-path polar operation. Circuits using polarential or two-path polar transmission do not require service adjustments to compen-

sate for variations in the electrical characteristics of the line due to changing weather conditions. Two-path polar circuits require two independent metallic conductors between two repeater points, whereas polarential circuits require but one metallic conductor. (Both operate ground return.)

a. POLARENTIAL OPERATION. Fundamentally, a circuit operating on a polarential basis uses polar transmission in one direction and differential transmission in the other. These two terms have been combined to form the word polarential. In a polar transmission system, the marking and spacing line currents are of the same magnitude and flow in opposite directions; therefore, the receiving relay operates on reversals of line current and requires no local bias circuit. In a differential transmission system, the marking and spacing line current are different in magnitude. This difference requires a spacing current about two and one half times the marking current since the spacing current is in the same direction as the marking current. A repeater that receives marking and spacing current flowing in the same direction requires a local biasing circuit at the receiving relay. If this local biasing circuit is fixed in a marking direction, and the line winding of the receiving relay is poled to spacing, the net effect on the armature of the receiving relay is equivalent to polar transmission. Figure 156 is a simplified diagram of teletypewriter transmitting contacts connected to a differential sending relay within a repeater. This relay sends signals over the line to a differential receiving relay of another repeater which repeats the signals, in neutral form, to the receiving magnets of the other teletypewriter. For simplicity, all current values are assumed. When a transmitting contact closes, 60 ma of current flow through the loop circuit and the line winding of the differential sending relay. Because this winding is poled marking, the bias circuit is overcome by 30 ma, 60 minus 30, and the relay armature is caused to go to marking. This completes a circuit from ground, through the line and line winding of the differential receiving relay to the negative 75-volt d-c source (positive grounded). Because their winding is poled spacing, the current in the line circuit will tend to cause the armature to go to spacing. However, the bias winding (poled marking) effectively overcomes the spacing current by 14 ma, 32 minus 18, which causes the armature to move to the marking contact, repeating the signal, in neutral form, to the receiving magnets of the teletypewriter. If the transmitting contacts send a spacing

impulse to the sending repeater, there will be no current flow in the line winding of the sending relay and the bias winding current will cause the armature to go to spacing. This connects positive 115 volts in series with the line, the line winding of the receiving relay and negative 75 volts, causing the current to increase to 46 ma, flowing in the same direction as when a marking impulse is sent. This current flow through the winding of the differential receiving relay (poled spacing) in effect overcomes the current in the bias winding (poled marking) by 14 ma, 46 minus 32, causing the armature to repeat a spacing impulse to the receiving magnets of the teletypewriter. The only difference between marking and spacing impulses is in the amount of voltage applied to the line between repeaters and, because the resistance is constant, the line current changes accordingly. However, the receiving relay operates on the same amount in each case, 14 ma. (See fig. 156.) To obtain the equivalent of polar transmission in both directions on one teletypewriter channel, the opposite (differential receiving) end of a polar circuit is made dissimilar as regards the operating voltage applied to the line by a sending relay armature. Figure 157 is an illustration of teletypewriter contacts connected to a polar sending relay which sends signals over the line to a polar receiving relay. This latter relay repeats neutral signals over a loop circuit to the receiving magnets of another teletypewriter. All current values are assumed for descriptive purposes and should not be considered standard. When a transmitting contact closes, 60 ma of current flow through the line winding of the polar sending relay which, in effect, overcomes the current in the bias winding and causes the armature to move to marking. This connects positive 75 volts to the line which causes current to flow in a direction to cause the receiving relay armature to move to the marking contact, repeating a neutral marking signal to the receiving magnets of the other teletypewriter. When the transmitting contacts open, the bias circuit of the sending relay moves the armature to spacing. This connects negative battery of 75 volts to the line which causes current to flow in a direction to cause the armature of the receiving relay to move to spacing, repeating a neutral spacing signal to the teletypewriter selector magnets. Transmission, then, in the case of polar circuits, is accomplished by reversal of current on the line at the polar sending relay contacts. The schematic diagram (fig. 158) represents a system in which the repeaters are

equivalent to Repeater TG-30 except that the current assumed for the bias winding is the proper amount for a relay with an equal number of turns for both line and bias windings. The windings of the polar relays used in Repeater TG-30 do not have an equal number of turns. Here, the two circuits (polar and differential) are combined to permit each end to send and receive (not simultaneously) over one line with each teletypewriter obtaining home copy. The bias winding keeps the receiving relay from opening when the polar send relay is transmitting. When the differential send relay is transmitting, its receiving relay contacts will not open because of the polarity of the applied differential current. Figure 159 is an illustration of a mark and space signal received by each end of the polar circuit. In the study of the circuit, it must be remembered that the bias circuit of the differential receiving relay is poled marking and the line winding is poled spacing. That is, the bias winding tends to cause the armature to go to the marking contact at all times and the line winding tends to cause the armature to go to spacing. This is opposite to the working arrangement of the relays used in teletypewriters and must be thoroughly understood before a complete knowledge of polar circuits can be obtained.

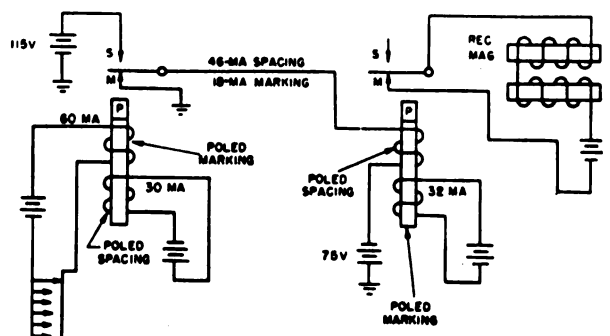

Figure 156. Simplified circuit diagram of differential operation.

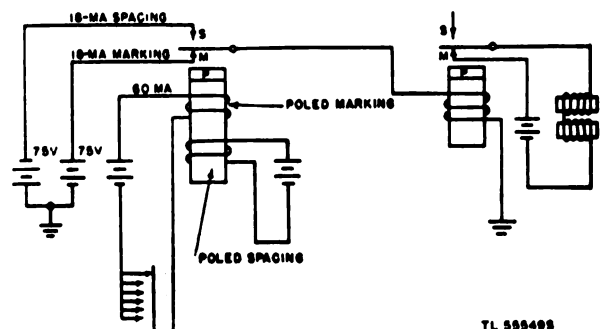

Figure 157. Simplified schematic diagram of polar operation.

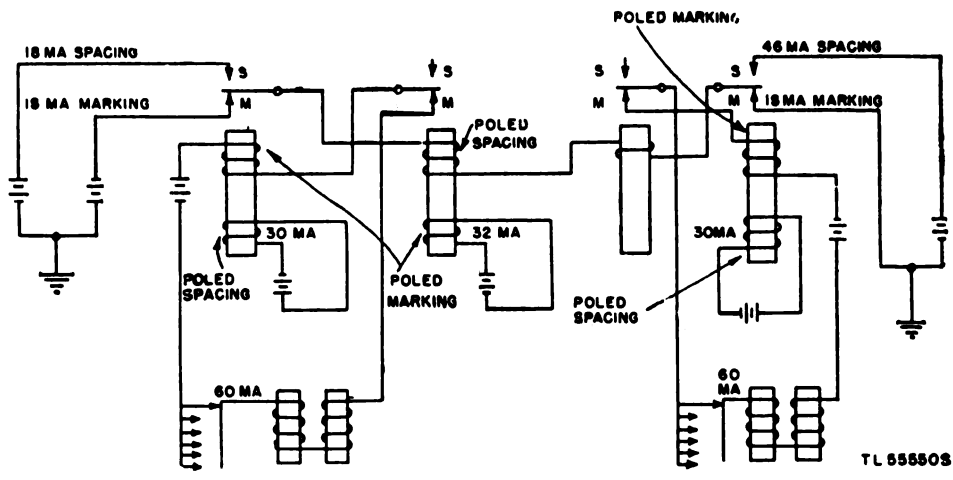

Figure 158. Simplified schematic diagram of polarential operation.

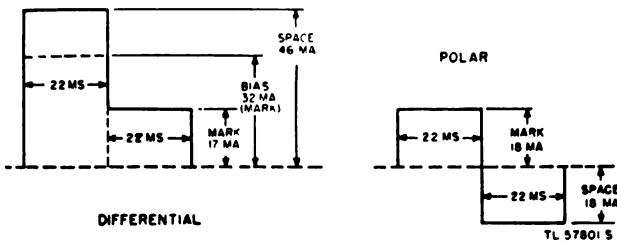

Figure 159. Theory diagram of waveshapes (polarential operation).

teletypewriters cannot send and receive at the same time because the local side of the repeater can be connected for half-duplex operation only. The operation of two Repeaters TG-30 operating on two-path polar is illustrated in figure 160. Circuit operation in each direction is the same as with the polar send circuit used with polarential operation. The send relay operates on neutral signals sent from the teletypewriter, repeating them over the line in polar form to the other station's receive relay. This relay changes the signals to neutral form, repeating them to that station's teletypewriter over the local circuit. Because all signals sent over the line are reversals in polarity, less distortion is present and greater distances can be obtained

b. TWO-PATH POLAR OPERATION. Two-path polar line transmission uses one circuit for transmission in each direction. The circuits of the sending and receiving relays at each end are identical. Though two individual circuits are used on the line side, the

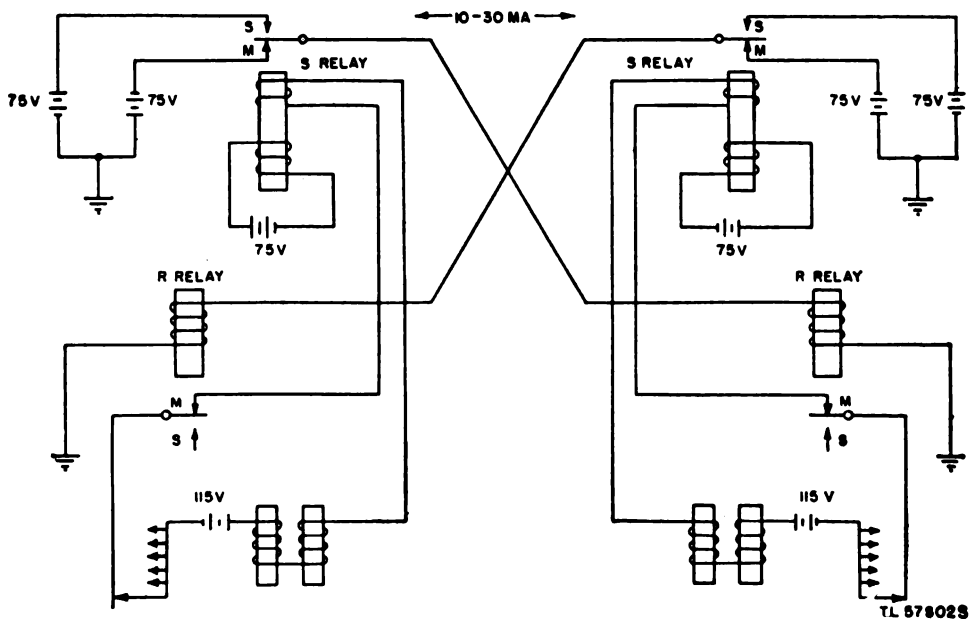

Figure 160. Simplified schematic diagram of two-path polar operation.

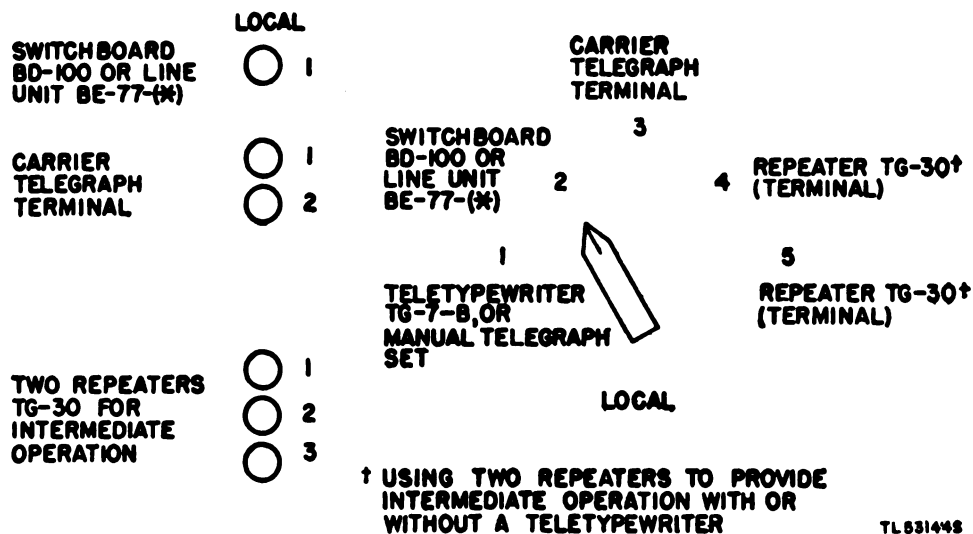

Figure 161. Function of local binding posts and LOCAL switch.

between repeaters. However, one distinct disadvantage is that two individual circuits between repeaters are necessary. The repeaters will function satisfactorily on two-path polar operation with line current anywhere between 10 and 30 ma, in each circuit.

c. SERVICE APPLICATION. Repeater TG-30 is designed for the interconnection and operation of several types of equipment on both the line and local sides. The line side may be connected and operated either polarential or two-path polar, but operation on the local side must be neutral half-duplex. The procedures for connecting and operating the line side is the same regardless of the type equipment to which the repeater is connected. Connection and operation of the local side to teletypewriter equipment is all that is covered in this text as that is the chief concern of the teletypewriter mechanic. The line and local circuit features required for different types of service are obtained by turning a LINE switch and a LOCAL switch to specific positions and by connecting the conductors to specific LINE and LOCAL binding posts. The LINE switch is a three-position switch, and the LOCAL switch has five positions. Two LINE, one GND, and three LOCAL binding posts are used for the individual installations. Some binding posts are not used for connection to certain equipment. Figures 161 and 162 illustrate the LINE and LOCAL connections and the position of switches for different types of equipment.

d. MANUAL TELEGRAPH SET. A manual telegraph set is built into the repeater as a means of communication when printer equipment is not available or cannot be operated. The headset is sup-

plied with a cord and plug for connecting to a jack in the repeater. The tone of the set is adjustable by means of a potentiometer with a knob located on the operating panel. The set is inoperative when a teletypewriter is connected for monitoring or communicating purposes.

e. LINE PROTECTION. Carbon block line protectors prevent damage to the equipment if line voltage surges occur. One pair of protector blocks is connected to each line binding post of the repeater. Two pairs are supplied as spares.

f. FILTERS. Repeater TG-30 has filters connected for suppression of noise in nearby radio equipment

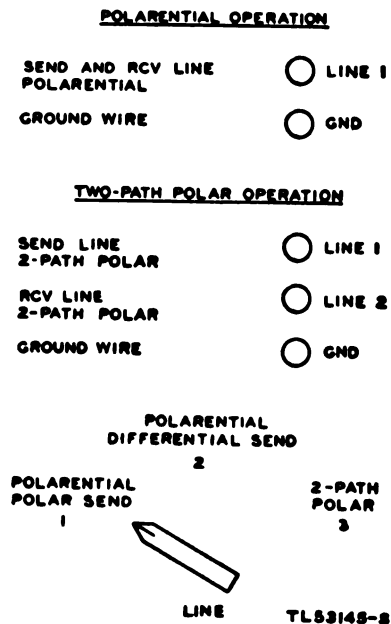

Figure 162. Function of line binding posts and LINE switch.

and to prevent undue noises in simplex telephone circuits.

g. RELAYS. The repeater has three relays of the same type. This relay (D-164816) is a three-winding relay and is arranged for mounting in a vacuum tube socket that serves as a connecting block. One winding is a 90-ohm winding and the other two are 1,450-ohm windings. Figure 164 is a schematic diagram of the relay.

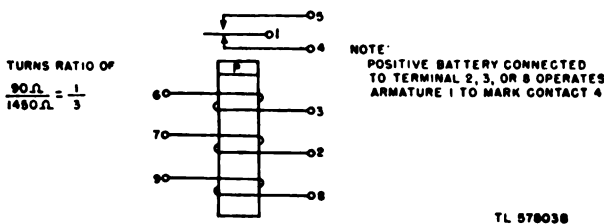

Figure 163. Schematic diagram of D-164816 relay.

h. OPERATING RANGES. The following operating ranges are provided as a guide in laying out circuits. They should not be used as absolute ranges under all conditions as the presence of earth potential, power line induction, or ground resistance reduces operating ranges. The distances specified for operation over field wire circuits are based on adverse weather conditions with wire laid on the ground and with correct and with correct orientation of the teletypewriters. The addition of an intermediate repeater would, of course, greatly increase the operating distances. Distance for operation of 404 operations per minute is also given in case it is desired to use Repeater TG-30 for the interconnection of American and British equipment.

Type of wire	368 OPM	404 OPM
W-110-B	50 miles	40 miles
W-143	75 miles	70 miles
104 mil copper	200 miles	200 miles
80 mil 40% copper-steel.....	95 miles	95 miles
104 mil 40% copper-steel.....	135 miles	135 miles

102. Installation and Operation

Installation of Repeater TG-30 consists of connecting a ground lead, line wires (conductors to other terminal or intermediate equipment) and local or loop wires (conductors to teletypewriter equipment); setting switches, knobs, etc., for the type of operation and power to be used; connecting power; adjusting the voltage and line current; and connecting the monitoring teletypewriter. In all local cir-

cuits, the current must be adjusted at the teletypewriter equipment. In general, local operation means that the teletypewriter equipment is located within a few hundred feet of the repeater. However, operation to teletypewriter equipment may be used up to 4 miles on field wire (simplex or multipled pair). As far as the teletypewriter mechanic is concerned, local operation will always be to some type of teletypewriter equipment. Therefore, only that type installation and operation will be outlined here. It is important that the monitoring teletypewriter be correctly oriented before it is connected for monitoring. A facsimile of the condensed operating instructions attached inside the cover of the repeater carrying case is shown in figure 174. All knobs, terminals, etc., are illustrated in figure 164.

a. GROUND CONNECTION. Since Repeater TG-30 is designed for operation on ground-return circuits, the resistance of the connection to earth is very important. Make every effort to obtain the best ground connection available in the area where service is to be established. Connection of the ground lead to the terminal marked GND effectively supplies ground for all circuits and operations.

b. POWER CONNECTION AND ADJUSTMENT. Check the power supply for voltage and see whether it is alternating current or direct current. The main power switch (a-c-d-c) must be set according to the type of power. If the power is alternating current, the power switch beneath the door at the lower right-hand corner must be set for the correct voltage. Do not plug in the power cord until the coarse adjusting knob for adjusting line current is turned all the way counterclockwise to prevent blowing a fuse in event the line resistance is low. One hundred volts of alternating current or direct current (according to primary supply) is available for operation of the monitoring teletypewriter motor at the outlet on the face of the equipment. This receptacle will receive either a polarized or nonpolarized plug. When direct current is used as the primary source of power, the voltage must be regulated at the source and the power cord must be connected so that the meter on the repeater reads to the right of zero when the MEAS. VOLTS key is held down. When a-c power is used, the key must be depressed and the voltage-adjusting knobs designated COARSE and FINE turned until the meter indicates 115 volts. This is designated by a red line on the meter.

c. CONNECTION AND ADJUSTMENT OF SIGNAL LINES. (1) Polarential operation. Polarential operation must be used over a ground-return circuit with

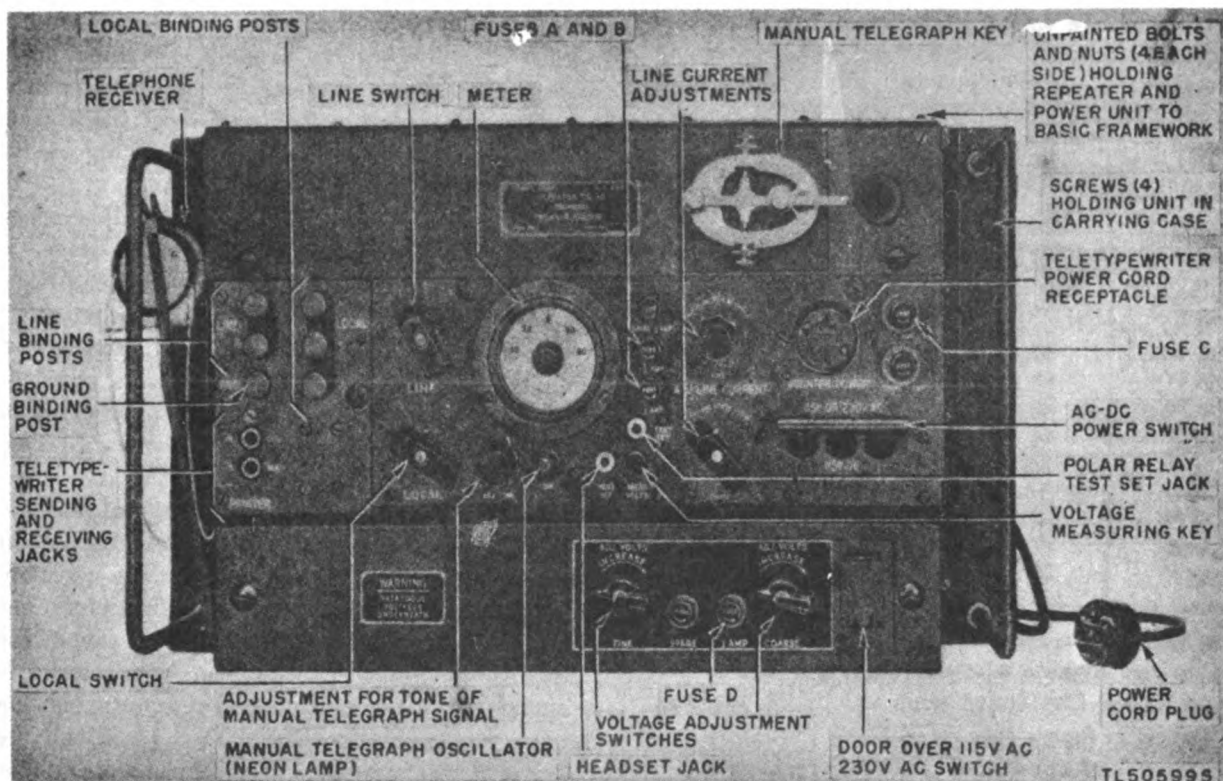

Figure 164. Top view of Repeater TG-30, removed from carrying case.

Repeater TG-30 and the metallic conductor must be connected to line terminal No. 1. Arrange the repeater at the control terminal as the polar sending repeater (LINE switch in position 1), and the repeater at the noncontrol terminal as the differential sending repeater (LINE switch in position 2). The line connections and switch positions for polar operation are illustrated in figure 165. Line current is adjustable only at the repeater set up for polar sending. After the voltage has been adjusted with the coarse adjusting knob in its maximum position, turn the FINE line current adjusting knob to its maximum increase position and the COARSE knob clockwise to its first position. This should result in at least 18 ma of line current. Then request the distant station to send a break signal for about 20 seconds. If the spacing line current is not 44 to 46 ma, it must be adjusted in accordance with the table in (2) below, taking into consideration the types of lines as shown. Any line-up subsequent to starting service should be made in accordance with this table. If the line-up requires readjustment of line current on a space signal from the distant point, the marking current will exceed 18 ma. The only line-up necessary at the differential sending repeater

is to send the break signal when it is requested. If local circuits are not connected, the monitoring teletypewriter or manual telegraph set may be used to line up the two repeaters when the LOCAL switch is in the No. 1 position. When the monitoring machine is connected, the telegraph set is automatically disconnected.

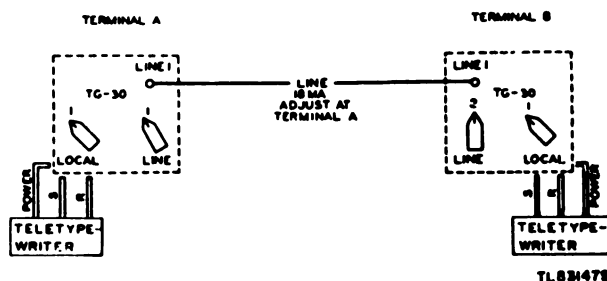

Figure 165. Line connections and switch positions for polar operation.

(2) *Two-path polar operation.* The send line is connected to line terminal No. 1, the receive line connected to terminal No. 2 and the LINE switch turned to position 3 for two-path polar operation. Line current can be adjusted in the sending circuit

only; the receive circuit line current is adjusted at the distant station.

Readjustment of Spacing Line Current in Respect to Type of Line.

Readjust spacing line current to be:

Spacing line current	104-mil copper-steel and field wire	104-mil copper	80-mil copper-steel
44 to 46 ma	No change	48 ma	44 ma
42 to 43	44 ma	46	43
40 to 41	43	45	42
38 to 39	42	44	42
36 to 37	41	43	41
34 to 35	40	41	40
32 to 33	39	39	40
30 to 31	38	38	39
28 to 29	37	37	38
26 to 27	36	36	38

Both line-current adjusting knobs should be turned to give the highest current obtainable but not to exceed 30 ma. Line connections and switch positions are shown in figure 166.

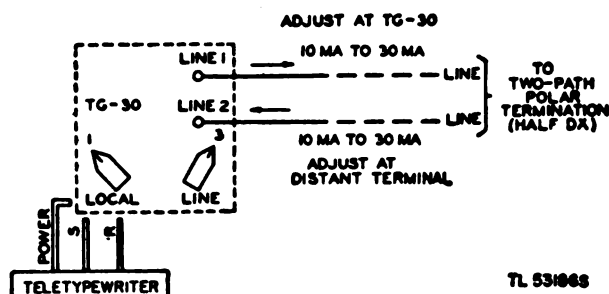

Figure 166. Line connections and switch positions for two-path polar operation.

(3) *Local circuit.* The circuit (ground-return) to teletypewriter equipment should be connected to the No. 1 LOCAL binding post and the LOCAL switch turned to its No. 2 position. (See fig. 167.) The circuit is connected at the teletypewriter equipment in the normal manner and negative battery (positive battery grounded) must be supplied and adjusted to 60 ma at that equipment.

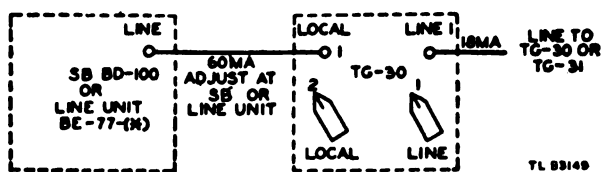

Figure 167. Line connections and switch positions for local circuit operation.

103. Maintenance

a. **GENERAL.** While the repeater equipment continues to function satisfactorily, no maintenance work is necessary other than occasional checks and adjustments of the polar relays and cleaning of the protector blocks.

b. **RELAYS.** The frequency of relay adjustments is determined by the amount of repeater usage. It can be assumed that in 24-hour-a-day service, a relay should be checked in a test set and adjusted about every 30 days. The relays may be removed by turning the relay compartment fasteners counter-clockwise, lifting the cover and pulling the relays upward. Test the relays and adjust them with Test Set I-193-A.

c. **LINE PROTECTORS.** Periodic checks of the line protectors are necessary to make sure the carbon blocks are smooth and not pitted and the assembly is free from dust and dirt. The protectors are located beneath the door on the left-hand side of the panel. An inspection of these protector blocks is recommended after every electrical storm in the area or every 30 days. The carbon block and the porcelain block, including the carbon insert, may be cleaned with clean cheesecloth. Replace cracked or pitted blocks, also any which cannot be wiped clean.

104. Telegraph Repeater OA-6/FC, General

Telegraph Repeater OA-6/FC, formerly D-C Telegraph Repeater X-61824 (Packaged) (fig. 168) that is a cabinet-inclosed unit consisting essentially of two complete repeaters that are similar to Repeater TG-30 and two rectifiers. Each rectifier requires a source of 115 or 230 volts 50-60 cycle alternating current for operation and the repeaters may be adapted to various forms of transmission on both the line and local sides. A monitoring teletypewriter is included as part of the repeater equipment. The relays used are identical to those of Repeater TG-30 and the operating range of Repeater TG-30 is applicable to Telegraph Repeater OA-6/FC. This repeater is normally located at higher echelons where it may be used as a terminal repeater, intermediate repeater, and, in some instances, is used in conjunction with generative repeaters to enable longer over-all lines. A terminal strip for making connections to the line and local extension circuits is provided within the cabinet as are filters for the suppression of noises in radio receivers. The line side of the repeater, as in Repeater TG-30, is designed to permit polar or two-path polar operation. The local extension

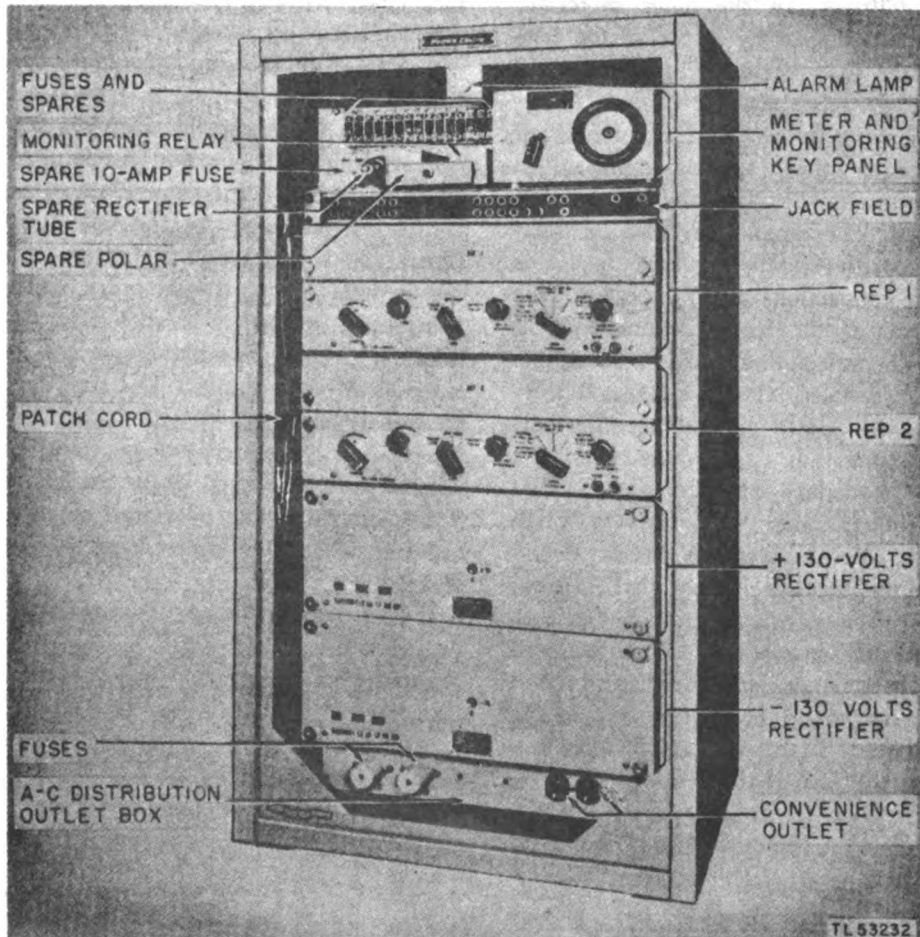

Figure 168. Telegraph Repeater OA-6/FC.

side (sometimes called the loop or drop side) is arranged for neutral half- and full-duplex, and two-path polar operation. It is not necessary that the line operations be outlined in this section as both types are fundamentally the same as with Repeater TG-30.

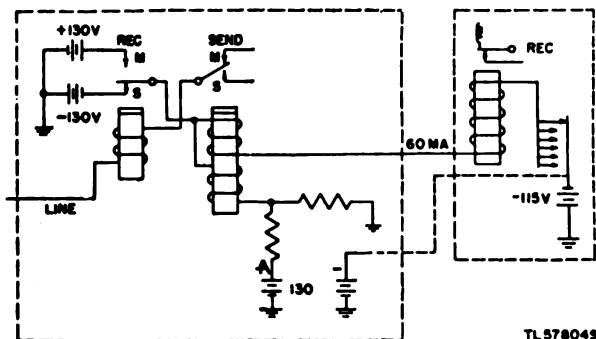

Figure 169. Local extension operating neutral to negative battery half-duplex.

a. HALF-DUPLEX LOCAL EXTENSION. Half-duplex operation is somewhat different with this repeater than with Repeater TG-30. If a ground-return circuit is used, battery must be supplied at both the teletypewriter station and at the repeater station. When a full-metallic circuit is used for the interconnection of the two stations, only the repeater supplies battery. However, the same amount of current (60 ma) flows in the circuits when either type connection is utilized. Figure 169 represents a repeater operating neutral to negative battery half-duplex. The marking local extension current is caused to flow by the application of positive battery at the receive relay of the repeater and negative battery at the teletypewriter station when a ground-return circuit is used. When a full-metallic circuit is used (broken lines, fig. 169), both positive and negative battery are supplied at the repeater. Transmission from the teletypewriter is accomplished in the normal manner, by the opening and closing of

the transmitting contacts. In the other direction, transmission is accomplished by applying the battery at the repeater in a series-aiding connection with the battery at the teletypewriter station (marking impulse) and having the two batteries connected so they will buck each other (spacing impulse). In this way, the equivalent of open-and-close transmission is obtained. The circuit may also be operated neutral to positive battery which means a reversal of battery connections at the repeater. This necessitates reversal of the battery connections at the teletypewriter as well and, for that reason, this type circuit cannot be used with Switchboard BD-100. The switchboard cannot ground negative battery without reversing the connections from the rectifier which will interfere with the working circuits of the switchboard and the circuits to which it is connected. The local extension circuit should always be neutral to negative battery, half-duplex, ground-return with battery supplied at the teletypewriter station when it is connected to Switchboard BD-100. The relay that receives the signals from the teletypewriter station is equipped with a bias circuit to enable it to operate properly on the neutral signals. IT IS VERY IMPORTANT THAT BATTERY BE SUPPLIED AT THE TELETYPEWRITER STATION ON GROUND-

RETURN CIRCUITS AND NOT SUPPLIED ON FULL-METALLIC CIRCUITS.

b. FULL-DUPLEX. Fundamentally, a full-duplex extension is two individual half-duplex circuits using two teletypewriters at the teletypewriter station, one for sending and one for receiving. The sending machine obtains home copy. Battery supply requirements are the same as for half-duplex operation. Operation of Telegraph Repeater OA-6/FC working neutral to negative battery, full-duplex, to a teletypewriter station is shown in figure 170. Individual circuit operation (send and receive) is the same as for half-duplex. The repeater may be used on this type operation with battery reversed (neutral to positive battery) since full-duplex operation normally is not used with Switchboard BD-100. Two-path polar line operation must be used at the repeater when full-duplex local extension operation is used.

c. TWO-PATH POLAR. Two-path polar operation on the local extension side is fundamentally like the two-path polar operation used on the line side and is intended, primarily, for use with British equipment which permits simultaneous sending and receiving of polar signals.

d. MONITORING TELETYPEWRITER. The monitoring teletypewriter at the repeater permits sending

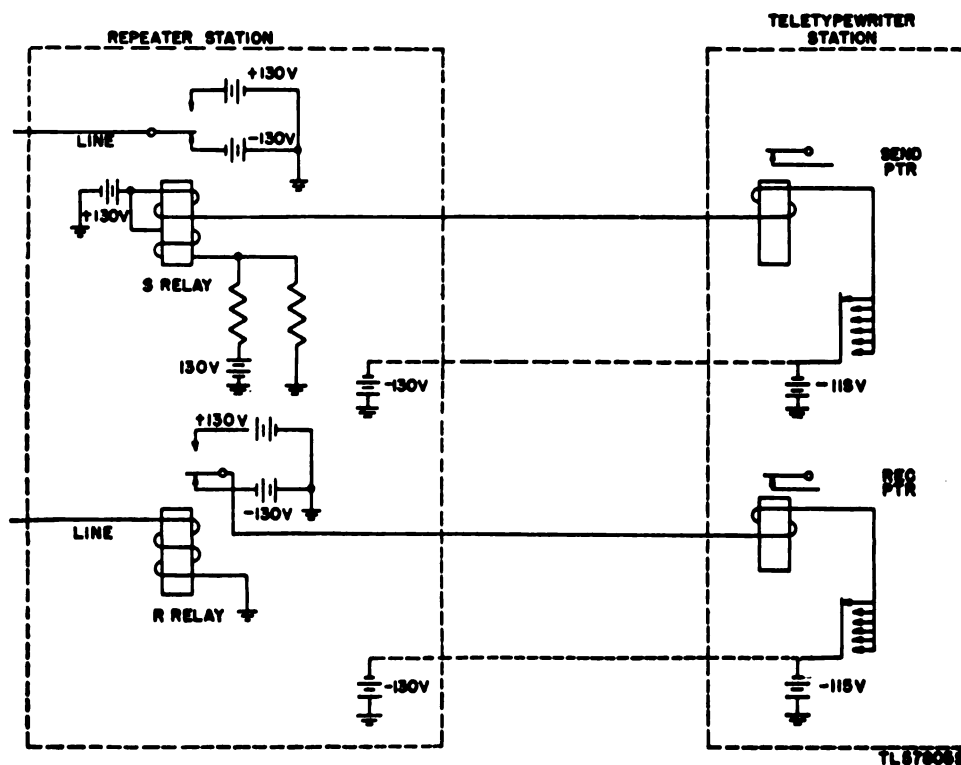

Figure 170. Local extension operating neutral to negative battery full-duplex.

and receiving in the local extension circuits except when they are arranged for two-path polar operation. The monitoring circuit contains a two-position switch to enable sending and receiving in circuits with either positive or negative battery applied.

e. **INSTALLATION AND OPERATION.** The line and local circuit features required for different forms of service are obtained by turning a **LINE** switch and a **LOCAL** switch (similar to TG-30) to specific positions and by connecting the conductors to specific **LINE** and **LOCAL** terminals. Unlike Repeater TG-30, the currents in the local circuits are supplied and adjusted at the repeater. A meter is incorporated within the cabinet and, by use of an eight-position switch, it can be arranged for measuring line and local extension current and can also be used to measure the output voltage of each rectifier. In order to obtain satisfactory operation with

Telegraph Repeater OA-6/FC, the resistance of the line including ground resistance should not exceed 3,250 ohms. The maximum length of a local extension circuit is 5 miles and if field wire is used it should be run aerially if possible.

105. Regenerative Repeater OA-3/FC

Signals repeated by Repeater TG-30 and Telegraph Repeater OA-6/FC depend upon the signals received by relays, making it possible for the repeaters to retransmit distortion that may be present in the received signals. This distortion may be repeated by the next repeater in the line and in long lines with several repeaters connected, the signal may become so distorted that correct operation of the teletypewriters is not possible. To offset this effect, regenerative repeaters are connected in longer lines. These repeaters permit greater over-all length

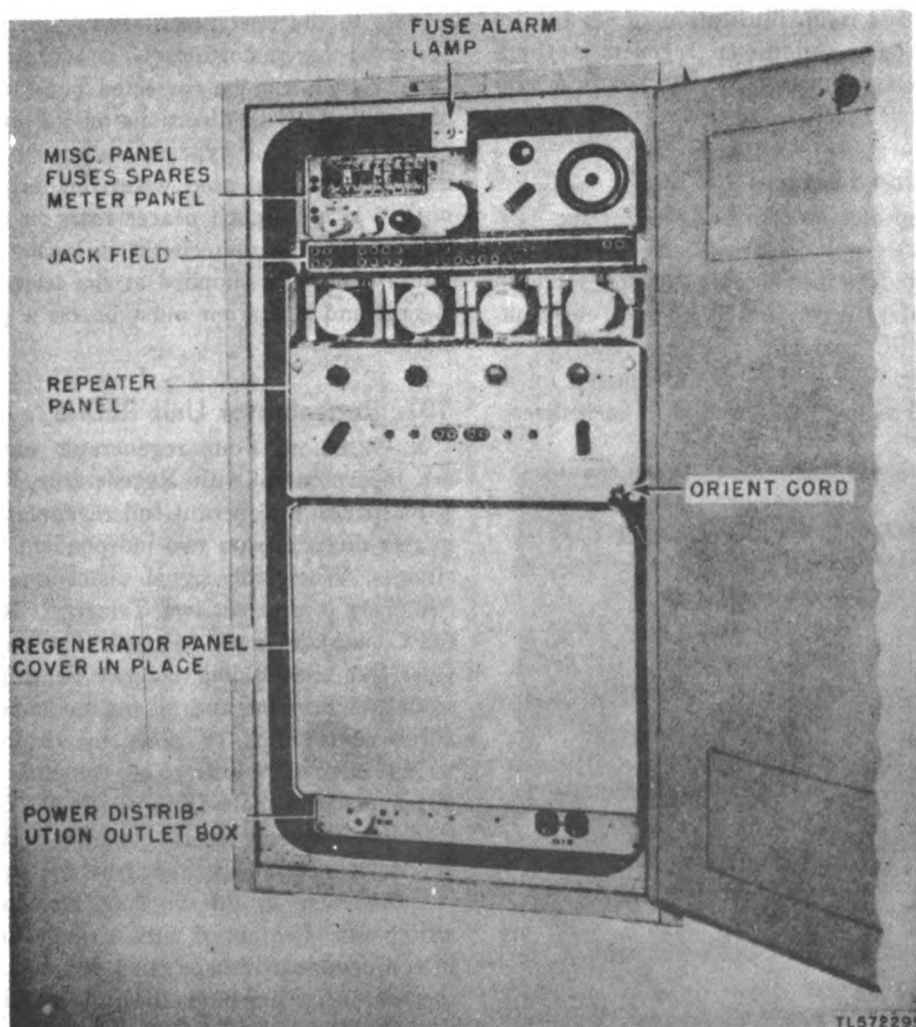
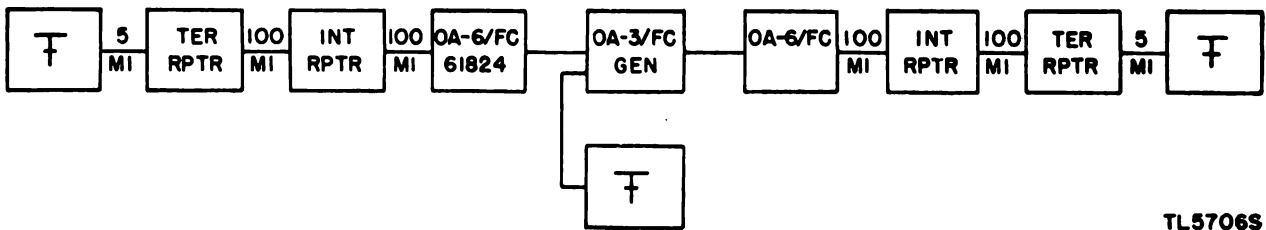

Figure 171. Regenerative Repeater OA-3/FC.



TL5706S

Figure 172. Use of Regenerative Repeater OA-3/FC.

of the line but do not permit greater distances between repeaters. Regenerative repeaters are normally located near and working in conjunction with Telegraph Repeater OA-6/FC since their maximum range is comparable to the range of a teletypewriter. In addition to regenerating the signals, they provide for another teletypewriter station on a branch circuit. The regenerative repeater is shown in figure 171, and figure 172 is an illustration of its use in teletypewriter circuits. Additional regenerative and intermediate repeaters may be used to obtain a still longer teletypewriter line.

106. Transmission Features

Regenerative Repeater OA-3/FC, formerly D-c Regenerative Telegraph Repeater X-66031A, is normally connected to the local extension circuits of the two repeaters incorporated in the Telegraph Repeater OA-6/FC package. The regenerative repeater may operate either full or half-duplex on a neutral basis and all signals repeated in each direc-

tion are without distortion. D-c power for circuit operation is obtained from the rectifier incorporated with the repeaters to which it is connected. A teletypewriter way station can be connected to the regenerative repeater which has the same effect as being connected in series with all other teletypewriters on the line. When the repeater is arranged for regeneration in both directions of the line, the signals to the teletypewriter way station cannot be corrected for distortion. If it is desired, however, these signals can be corrected but the transmission of signals in both directions on the line will not be regenerated. This type operation is normally not used but may be used when the terminal repeater on one side is much nearer than on the other side and the way station circuit is longer than normal. Battery must be supplied at the teletypewriter way station and operation must be on a ground-return circuit.

107. Regenerator Unit RED-8

a. GENERAL. Four regenerator units (RED-8) are incorporated with Regenerator Repeater OA-3/FC package to permit full regeneration of signals in two directions on two independent teletypewriter circuits. When full signal distortion correction on two lines is desired, two Telegraph Repeater OA-6/FC packages must be used. The units are somewhat like the holding magnet selector unit of the model 15 machine and all maintenance, repair, and adjustments must be done by qualified teletypewriter mechanics only. The function of each unit is to receive signals from one side of the line and transmit retimed signals to the other side. The maximum working distance of the individual unit is comparable to the working limit of a teletypewriter and is equipped with a range finder working in conjunction with a friction clutch. Like the selector unit of a machine, the unit requires about 20 percent of each individual impulse for correct mechanical reaction. The regenerator unit should be properly oriented to enable it to react mechanically

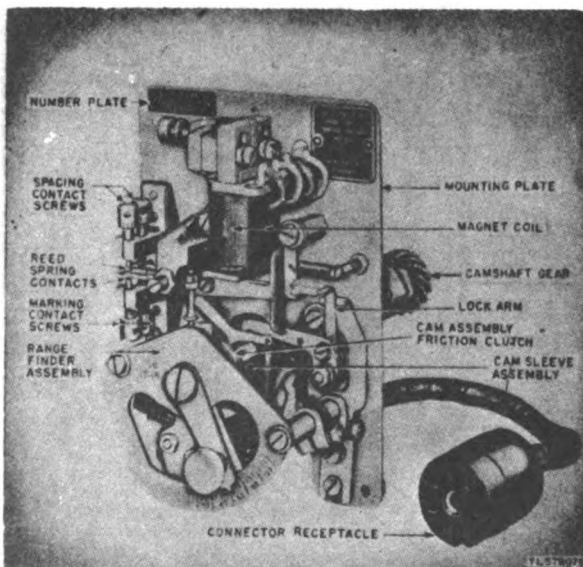

Figure 173. Regenerator unit of Regenerative Repeater OA-3/FC.

OPERATING INSTRUCTIONS - REPEATER TG-30 (TERMINAL)

LINE-UP PROCEDURE

OPERATION

- 1st CONNECT GROUND WIRE
- 2nd CONNECT LINE WIRES
- 3rd CONNECT PRINTER OR LOCAL WIRES
- 4th SET LINE SWITCH
- 5th SET LOCAL SWITCH
- 6th SET AMU LINE CURRENT SWITCH (COARSE)
- 7th THROW POWER SWITCHES
- 8th CONNECT POWER COORD
- 9th ADJUST VOLTAGE
- 10th ADJUST LOCAL CURRENTS
- 11th ADJUST LOCAL CURRENTS AND READJUST VOLTAGE AND LINE CURRENT

1. Connect ground wire to 6th binding post ①
2. Connect line wire to LINE 1 binding post ② for polarisential operation. Connect sending line to LINE 1 binding post and receiving line to LINE 2 binding post for 2-path polar operation.
3. a. Printer **TB-7-1**.--Connect red plug to RED Jack B ⑩. connect black plug to BLUE Jack ⑪ connect printer power cord to PRINTER POWER receptacle ⑫.

b. Local Wires

- (1) With Switchboard **BP-100** or Line Unit **BE-77-A** or Printer Station.--Connect wire to LOCAL 1 binding post ⑬.
- (2) With Telegraph Terminal **CF-2-1** (Carrier).--Connect LOCAL 1 binding post to 3. and LOCAL 2 binding post to 4. in carrier terminal.
- (3) Intermediate Operation with Two Repeaters **TB-20**.--Connect binding posts LOCAL 1 to LOCAL 4, LOCAL 2 to LOCAL 2, and LOCAL 3 to LOCAL 3.
- (4) With Repeater **TB-20** (Electronic Regenerative).--Connect binding posts LOCAL 1 to 1 LINE A and LOCAL 2 to 2 LINE A from one Repeater **TB-20**. Connect LOCAL 1 to 1 LINE B and LOCAL 2 to 2 LINE B from other Repeater **TB-20** if employed.

4. Turn LINE switch knob ④.
- Position 1 for Polarisential, Polar Sending (Terminal A)
- Position 2 for Polarisential, Differential Sending (Terminal B)
- Position 3 for 2-path Polar
- Use same position of LINE switch for both repeaters at an intermediate point.
5. Turn LOCAL switch knob ⑤.
- Position 1 for Printer **TB-7-1** or Manual Telegraph Operation
- Position 2 for Switchboard **BP-100** or Line Unit **BE-77-A** or Printer Station
- Position 3 for Telegraph Terminal **CF-2-1** (Carrier)
- Position 4 for Intermediate Operation (Direction A with Printer, if required.)
- Position 5 for Intermediate Operation (Direction B without Printer)
- Position 5 for Repeater **TB-20** (Electronic Regenerative)
6. Turn AMU LINE CURRENT switch knob ⑦ COARSE to maximize counter-clockwise position if LINE switch is in position 1 or 2.
7. a. If power supply is a.c.--Open panel ⑮ and throw switch ⑯ to 115V AC or 230V AC as required. Throw power switch ⑭ to 115V OR 230V AC position. A c power must be 50 to 60 cycles.
- b. If power supply is d.c.--Throw power switch ⑯ to 115V DC position.
8. Connect power cord ⑰ to power supply.

9. a. For d-c power supply.--Hold down HEADS WOLTS key ⑱ and turn AMU WOLTS knob ⑲ COARSE and FINE until meter reads 115V.
- b. For d-c power supply (gas cooled).--Hold down HEADS WOLTS key and adjust voltage at meter. Turn over power cord if meter reads to left of zero.

10. a. At a polar sending repeater LINE switch in position ①.--Turn AMU LINE CUR REPT knob ⑲ FINE to maximize clockwise position. Turn COARSE knob clockwise to first position that gives at least 10 Mh. Turn FINE knob as required to give 10 Mh. Repeat distant terminal to send spacing signal for about 10 seconds by holding down break key of printer. Read space current and adjust space current as follows for types of lines as shown:

Headjust Space Current to be	
Space Current	Headjust Space Current to be
80 mill Copper-steel	80 mill Copper-steel
Binding on Meter	10's mill Copper
44 to 48 MA	No change
49 to 51	43
56 to 57	45
58 to 60	47
61 to 63	49
64 to 66	51
67 to 69	53
70 to 72	55
73 to 75	57
76 to 78	59
79 to 81	61
82 to 84	63
85 to 87	65
88 to 90	67
91 to 93	69
94 to 96	71
97 to 99	73
100 to 102	75
103 to 105	77
106 to 108	79
109 to 111	81
112 to 114	83
115 to 117	85
118 to 120	87
121 to 123	89
124 to 126	91
127 to 129	93
130 to 132	95
133 to 135	97
136 to 138	99
139 to 141	101
142 to 144	103
145 to 147	105
148 to 150	107
151 to 153	109
154 to 156	111
157 to 159	113
160 to 162	115
163 to 165	117
166 to 168	119
169 to 171	121
172 to 174	123
175 to 177	125
178 to 180	127
181 to 183	129
184 to 186	131
187 to 189	133
190 to 192	135
193 to 195	137
196 to 198	139
199 to 201	141
202 to 204	143
205 to 207	145
208 to 210	147
211 to 213	149
214 to 216	151
217 to 219	153
220 to 222	155
223 to 225	157
226 to 228	159
229 to 231	161
232 to 234	163
235 to 237	165
238 to 240	167
241 to 243	169
244 to 246	171
247 to 249	173
250 to 252	175
253 to 255	177
256 to 258	179
259 to 261	181
262 to 264	183
265 to 267	185
268 to 270	187
271 to 273	189
274 to 276	191
277 to 279	193
280 to 282	195
283 to 285	197
286 to 288	199
289 to 291	201
292 to 294	203
295 to 297	205
298 to 300	207

Refer to instruction book for more complete table.

b. At a 2-path polar repeater LINE switch in position ②.--Adjust current in sending line to 30 MA by AMU LINE CURRENT knob.

11. a. Adjust local current in connected equipment.
 - Switchboard **BP-100**, Line Unit **BE-77-A** or Printer Station 60 MA
 - Telegraph Terminal **CF-2-1** (Carrier) 60 MA
 - Repeater **TB-20** (Electronic Regenerative) 30 MA
 - Repeat 9, 10, and 11 and readjust as required.

SERVICE MAINTENANCE

Maintain voltage adjustment at 115V.

All line current adjustments should be according to TM 11-2004.

MISCELLANEOUS

Manual Telegraph Operation.--Remove all printer cords. Connect Headset to HEADSET Jack ⑱. Turn AMU WOLTS knob ⑲ to emit while operating telegraph key.

Polar Relay Testing.--Refer to TM 11-2004.

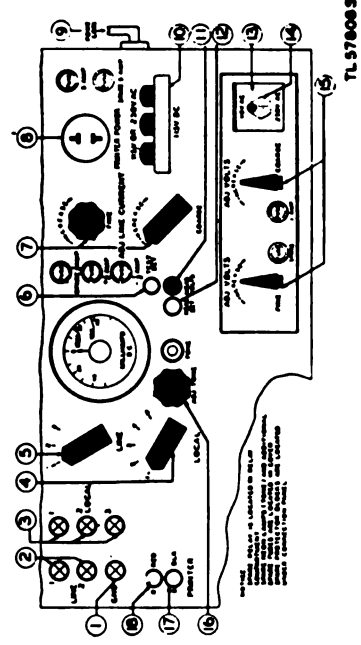

Figure 174, Operating instructions, Repeater TG-30 (Terminal, Telegraph).

on the best part of the received impulse. All four units are driven by a single motor through the medium of a countershaft. An illustration of the regeneration unit is shown in figure 173 which should be used as reference for the following paragraph.

b. SEQUENCE OF MECHANICAL OPERATION. The incoming circuit of each regenerator unit is connected to the holding selector magnets and the outgoing circuit is connected to a contact reed. The contact reed works in conjunction with two pairs of contacts to send marking and spacing impulses. The magnet armature is held against the pole-piece face of the magnet when the unit is in an idle condition and the contact reed is locked in its marking position. The reception of a start impulse causes the armature to be released and the cam assembly is allowed to rotate. Because the armature is in the spacing position, it applies spring tension to the contact reed in a manner that tends to pull it to the lower (spacing) position. The reed, however, is locked in the marking position by the lock arm. At about the middle of the start impulse, a high part of the locking cam is presented to the lock-arm lever which causes the lock arm to release the contact reed. The tension exerted at the contact reed centralizing spring by the magnet armature causes the contact reed to be pulled to the spacing position and the start impulse is retransmitted. The contact reed is locked in the spacing position by the lock arm as soon as it is moved to that position and is kept locked until another high part of the locking cam is presented to the lock-arm lever. Because the high parts of the locking cam are located so that it takes a definite length of time for the lock-arm lever to ride from one to another, the contact reed will be locked in the spacing position for that definite length of time. Except when operating with British equipment, the time for the lock-arm lever to ride from one high part to another is 22 milliseconds. Thus, the start impulse retransmitted will be perfect regardless of the distortion in the incoming signal unless distortion is present when the contact reed is released. Assuming that the first intelligence impulse is marking, the magnet armature is presented to the pole faces by action of its cam and is retained there. The armature causes the reed centralizing spring to exert tension on the contact reed in a manner that tends to cause it to move to marking. When the locking cam again causes the contact reed to be released (about the middle of the received impulse), the contact reed

will be pulled to its marking position and held there until again released by the locking cam (normally 22 milliseconds). All other impulses of the character are received and transmitted in the same manner with the exception of the stop impulse which is timed, normally to 31 milliseconds. If the portion of each received impulse is unaffected by distortion when the contact reed is released, the resulting signal will be like one originating from a teletypewriter. All impulses must be received by the unit for retransmission of the correct character. Any variation from correct motor speed will, of course, make the locking cam speed vary and consequently affect the length of the repeated signal.

c. HOLDING CAM. Another cam is located on the cam sleeve that operates two pairs of contacts through an associated lever. These relay holding contacts are included to permit proper functioning of an associated relay when a teletypewriter way station is connected to the regenerative repeater.

d. MAINTENANCE. Maintenance of regenerator unit RED-8 consists of the same preventive maintenance practices as used with the selector unit of a teletypewriter. Conditions prevailing may cause variations in routine intervals. However, it is recommended as a guide, that the unit be cleaned, readjusted if necessary, and lubricated after 350 hours of service or at least every 3 months and the motor be cleaned and lubricated after 700 hours of service. Mechanical requirements and lubrication specifications may be found in TM 11-2032.

SECTION VI. CONNECTION OF SWITCHBOARD BD-100 TO COMMERCIAL TELETYPEWRITER SYSTEMS

108. General Introduction

Connection of Switchboard BD-100 to commercial teletypewriter systems is accomplished by use of Relay Unit BE 84-A (Teletype Trunk). Normally, this unit is used only within the continental United States. Relay Unit BE 84-A (Teletype Trunk) is similar to Repeater TG-30 in both design and operation except that supervising and biasing circuits are provided and polarential operation is the only type of line operation that can be used on the relay unit. Neutral operation is used to Switchboard BD-100. The signaling circuit permits what is known as open-line supervision. That is, current flows in the line circuit only while the line circuit is actually in use. The relay unit is located with the

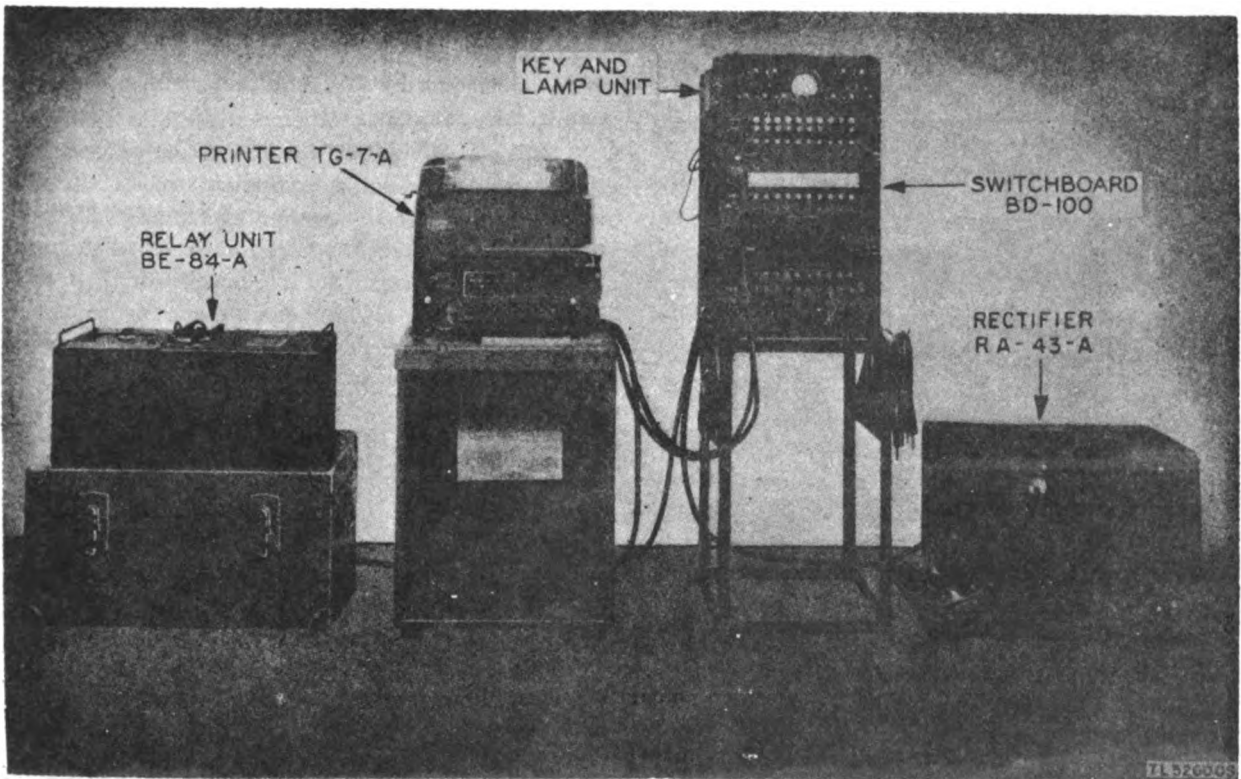

Figure 175. Switchboard BD-100 set up for operation to commercial TWX.

army switchboard and is designed, primarily, for operation over commercial conductors. If two lines to the commercial equipment are needed, another relay unit must be added. A typical installation of Switchboard BD-100 and associated equipment set up for operation to commercial teletypewriter exchange (TWX) using Relay Unit BE 84-A is shown in figure 175. Figure 176 is a schematic diagram of an over-all circuit with equipment connected.

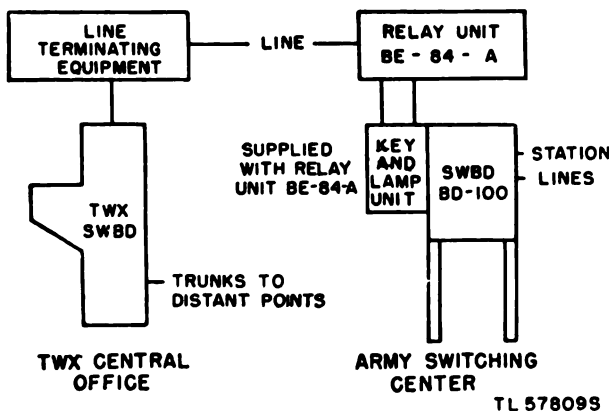

Figure 176. Schematic diagram of Switchboard BD-100 connected to commercial TWX.

109. Description

The equipment comprising Relay Unit BE 84-A is assembled in a compact metal cabinet with all controls mounted on a top panel. Power for line circuit operation is obtained from a selenium disk rectifier incorporated within the metal cabinet. Three polar relays provide full repeating facilities for one line. Supervision for the line is obtained by use of a key and lamp unit that is permanently wired to the relay unit and has wires for connection to line terminals of Switchboard BD-100. The key and lamp unit is fastened to the switchboard for use by the switchboard operator. The receiving relay may be biased by varying the amount of current in the bias winding. A rheostat is connected to the bias winding for that purpose. A meter is installed on the top panel for measurement of rectifier voltage and bias of the receiving relay. All parts may be boxed in a wooden carrying case for transportation. The case is equipped with shockproofing material for protection during transportation. The entire relay unit in its carrying case is shown in figure 177. Figure 178 illustrates the relay unit with compartment door open, showing the position of relays, terminals, control knobs, etc.

a. **POWER REQUIREMENTS.** Approximately 60 watts of 115-volts 50- to 60-cycle alternating current is required for the rectifier. The rectifier supplies 75 volts direct current for line operation. Power for the loop (to switchboard) circuit and the supervisory relays is obtained at the switchboard. The required power for operation of these circuits is approximately the same as any substation line at Switchboard BD-100. The meter of the relay unit may be used as a voltmeter and the output of the rectifier adjusted by a potentiometer. Correct output voltage (75 volts) is designated by a red line on the meter scale.

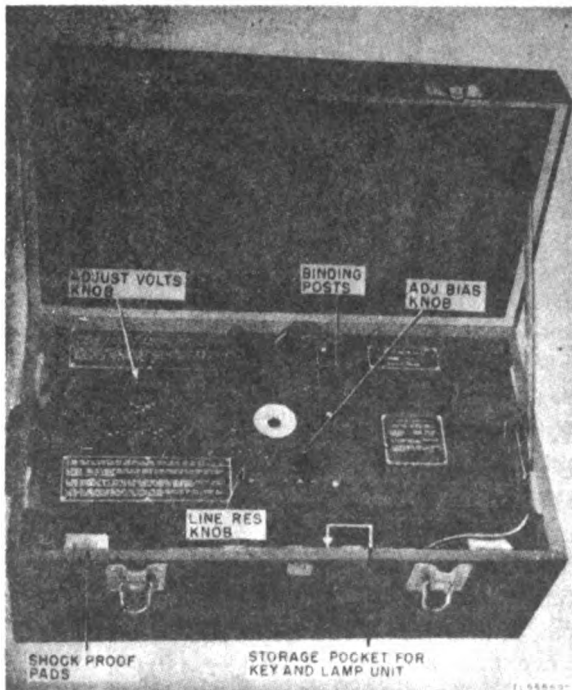

Figure 177. Relay Unit BE-84-A in carrying case.

b. **TRANSMISSION FEATURES.** Operation of the relay unit to a TWX station is the same as any repeater working polar, polar send on the line side. The loop side of the unit operates neutral in the same way as any line connected to Switchboard BD-100, except the current to the relay unit is adjusted at the switchboard to 30 ma instead of the regular 60 ma. Current on neither the line nor the local side is adjusted at the relay unit. When the unit is sending to Switchboard BD-100, ground is supplied for a marking signal, completing a circuit to the negative 115 volts applied at the switchboard. For a spacing impulse, negative 115 volts is applied at the relay unit which opposes the nega-

tive 115 volts at the switchboard and no current flows in the loop circuit. Apparatus is furnished to enable service to the TWX to be arranged on a one-wire to two-wire basis.

c. **FILTERS.** When two-wire operation is used, one wire and its associated equipment serves to neutralize the effects of ground potentials, 25-cycle power induction and other forms of distortion. With one-wire operation, a 60-cycle filter is used in the signal line to reduce interference from power lines that use this frequency. Contacts of the polar relays and the a-c power cord are equipped with filters, and capacitors are connected to the line terminals. These are provided to reduce interference to radio receiving equipment.

d. **METHOD OF SUPERVISION.** Because the line side of the relay unit operates on an open circuit basis, a means of signaling from one station to the other is essential. This is accomplished from the TWX station to the relay unit by using an a-c relay in the relay unit which, when energized, breaks the circuit to the switchboard, causing the signal lamp of Switchboard BD-100 to light. The TWX operator operates this relay by applying 20-cycle ringing current on the line. Signaling in the other direction is accomplished by operating the TWX switch of the key and lamp unit to ON, completing the line circuit and causing the signal lamp at the TWX switchboard to glow. A functional schematic diagram of the unit is shown in figure 179.

e. **SEQUENCE OF CIRCUIT OPERATION (SIGNALING).** Figure 180 shows the sequence of circuit operation when the TWX operator signals Switchboard BD-100. A cord is connected to the line jack at the TWX switchboard and 20-cycle ringing current is applied. This causes (D) relay to operate its armature to the make contact which completes the circuit to relay (D). When this relay operates, ground is removed from the circuit through Switchboard BD-100's line relay. The signal relay reacts just as when any line is momentarily broken and the signal lamp of the switchboard is caused to light. As soon as the ringing current is removed, relay (D) will assume its normal position and the circuit to the line relay of the Army switchboard will be closed. The signal lamp will remain lighted, however, because of the wiring of its signal relay. The operator at the teletypewriter switchboard answers the call by depressing the answer key and throwing the TWX key to OFF. This extinguishes the lamp in Switchboard BD-100 and sets up a circuit as shown in figure 181. Operation of the TWX

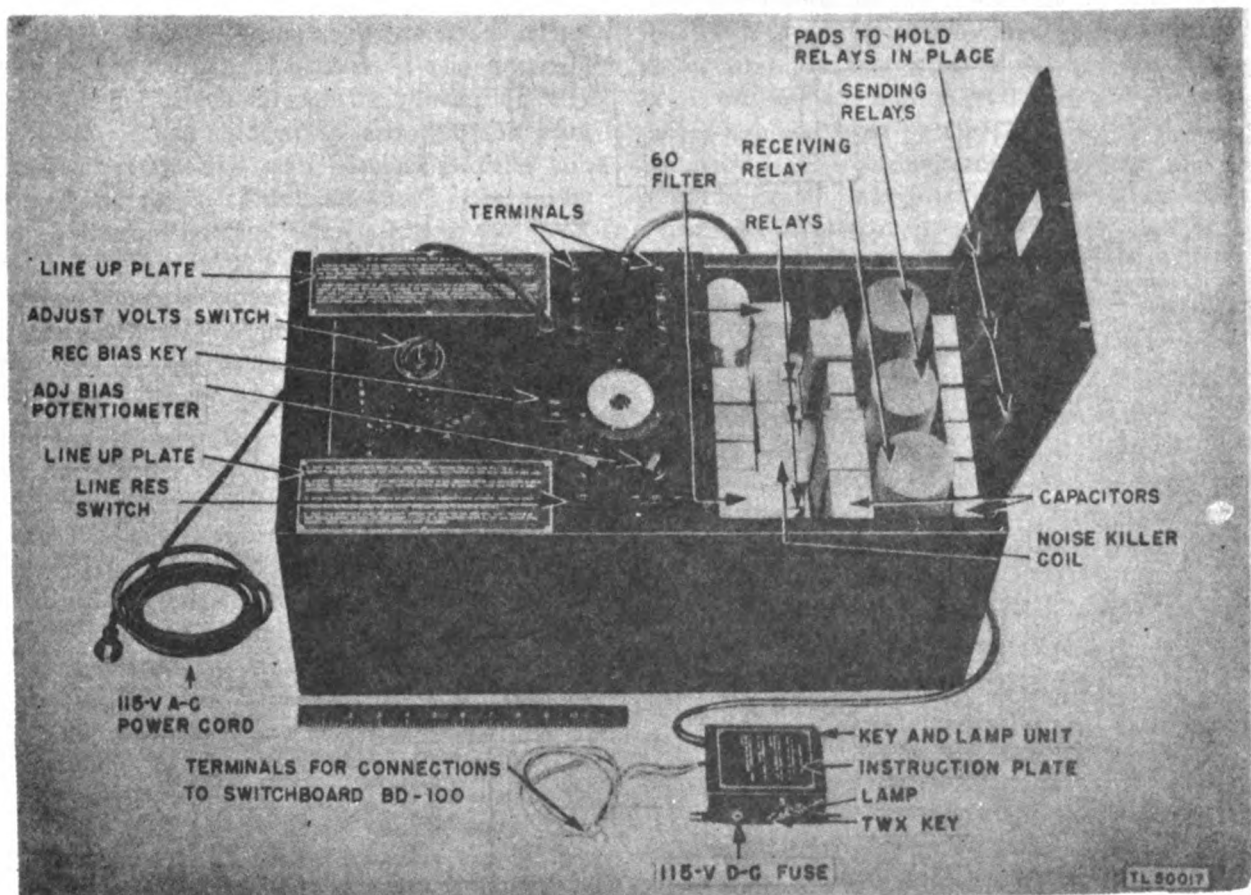
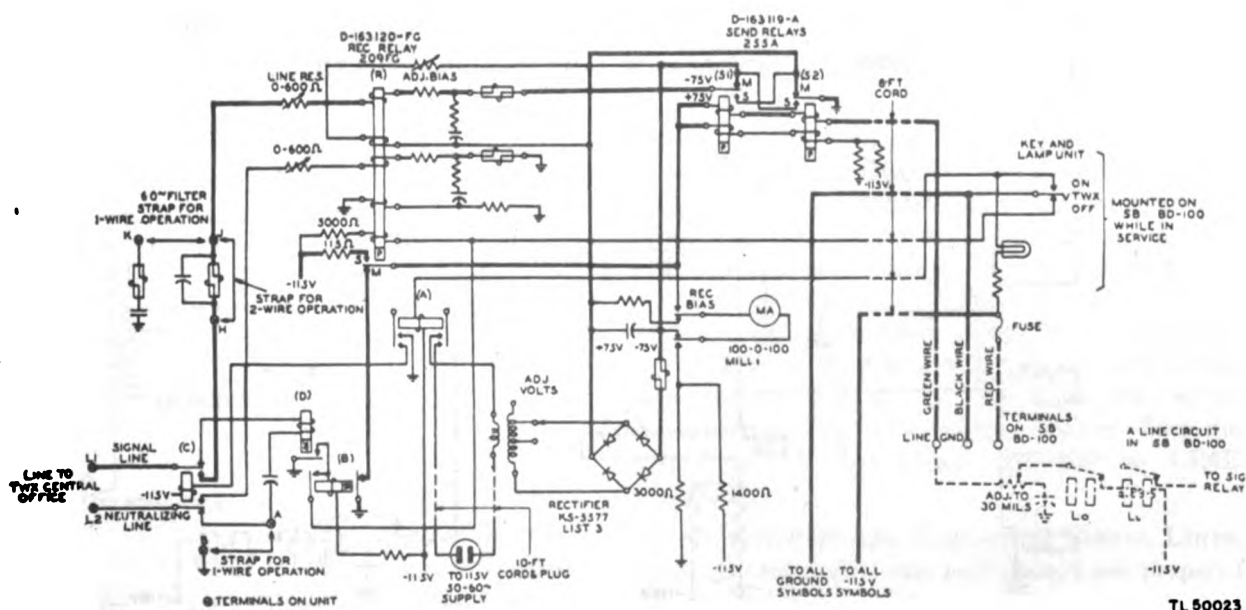

Figure 178. Relay Unit BE-84-A, compartment door open.



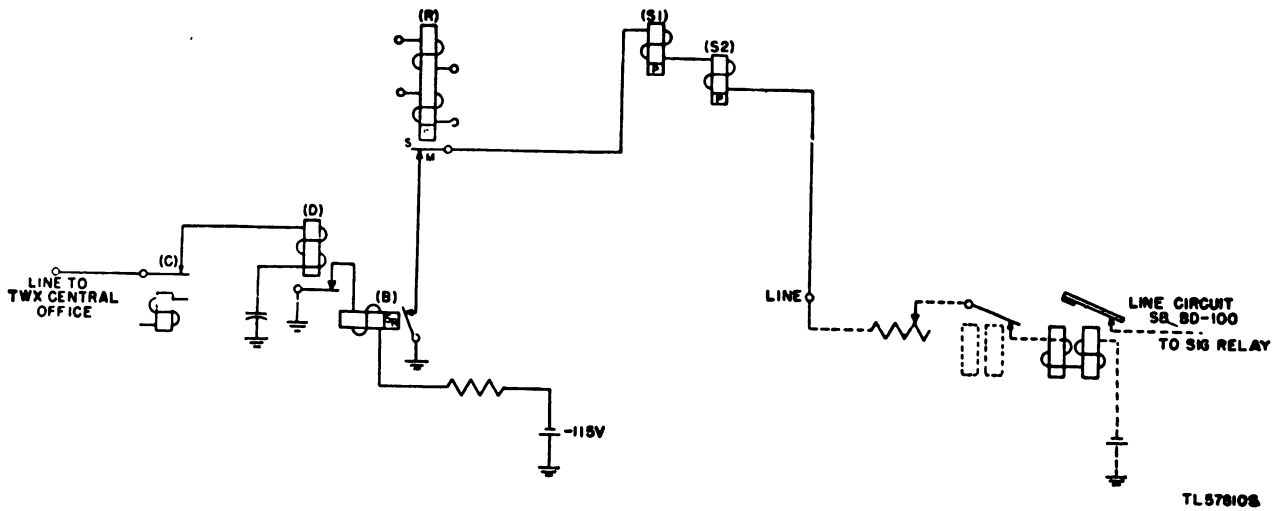

Figure 180. Signaling circuit (TWX to Switchboard BD-100).

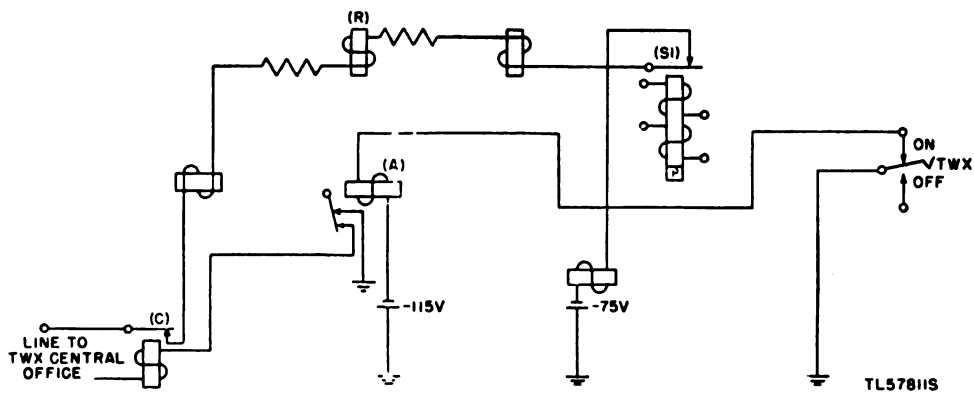

Figure 181. Signaling circuit (Switchboard BD-100 to TWX).

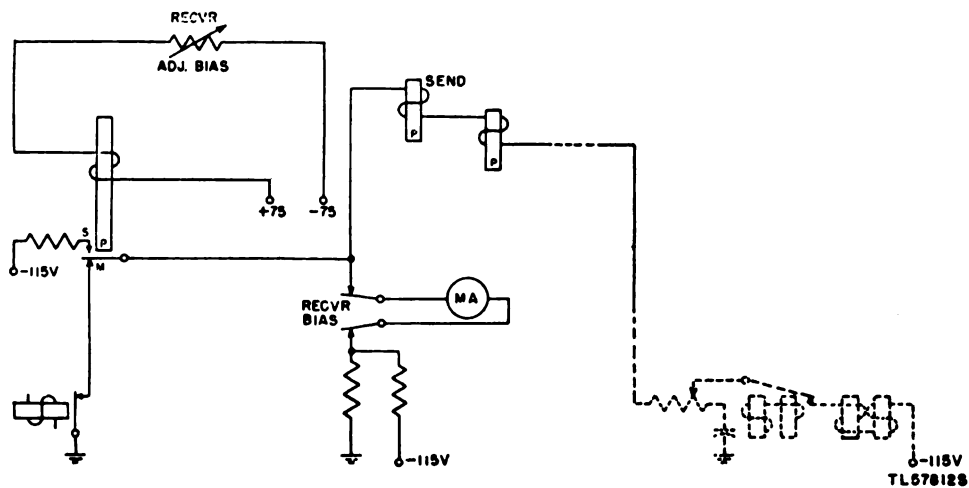

Figure 182. Bias circuit of Relay Unit BE-84-A.

key to the ON position connects ground to a circuit through relay (A) which completes a circuit through relay (C). The latter relay's armature closes the line circuit through the winding of relay (R), receive, and through the armature and mark contact of relay (S1), send, enabling the relay unit to send and receive. This same circuit is set up by the switchboard operator when a call to the TWX is desired. The TWX key is operated to the ON position, closing a circuit so that a lamp is caused to glow at the TWX board. The operator at that board will answer the lamp signal in a prescribed manner.

f. BIAS MEASUREMENT. The bias measurement circuit is similar in operation to the bias measurement circuit in Line Unit BE-77-A and Switchboard BD-100. A functional schematic diagram is shown in figure 183. When the REC BIAS button is depressed, the meter is removed from the normal connection to the rectifier and connected to an unbalanced bridge circuit across the armature and contact of the relay unit receiving relay. Negative 115 volts is supplied for a received spacing impulse and ground for a received marking impulse. The receiving relay is biased by varying the amount of current in the bias winding. A rheostat, ADJ. BIAS, is included in the relay bias current for this purpose. Battery for the bias circuit is obtained at Switchboard BD-100 by the connections for the key and lamp unit.

g. MISCELLANEOUS CIRCUIT OPERATIONS. Because the rectifier input circuit is in series with the contacts of relay (A) and the winding of relay (A)

is in series with the make and floating contacts of the TWX key, the rectifier input will be disconnected when the line is not in use and the TWX key is off. The guard lamp on the key and the lamp unit is also controlled by the TWX key. Therefore, the guard lamp is an indicator for the relay unit as it will be lighted as long as the rectifier is on. These circuits are illustrated in figure 183.

110. Installation and Operation

It is necessary to communicate with the TWX station before installations of Relay Unit BE-84-A is begun, because the line conductors at the TWX station must be connected prior to lining up the relay unit for service since the line-up procedure requires the cooperation of a TWX attendant. The relay unit must be located near Switchboard BD-100 as an 8-foot cord is permanently connected between the key and lamp unit and the relay unit. Screws for mounting the key and lamp unit are included in the carrying case. The TWX station will designate whether one-wire or two-wire operation is to be used. Cording connections are illustrated in figure 184, along with a top panel diagram.

a. PREPARATION FOR USE. The relay unit should be removed from its carrying case and the carrying case used as a table for the unit. The key and lamp unit is designed to fasten to the upper left side of the switchboard (fig. 175) by screws kept in the storage pocket of the carrying case. Three wires, red, black, and green, which are permanently connected to the key and lamp unit, should be connected to terminals of Switchboard BD-100 as follows: Red wire to negative battery terminal, black wire to ground terminal, and green wire to the line terminal of the line to be used. The ground (black) wire effectively grounds the entire relay unit; the power (red) wire supplies power for the relay unit except for the line to the TWX station, and the loop (green) wire connects the relay unit to the line relay of Switchboard BD-100. After the key and lamp unit is installed, adjust the current in the loop circuit to 30 milliamperes at the switchboard line rheostat and the local relay of the switchboard to zero bias in the regular manner. Turn the meter key of Switchboard BD-100 to LINE CURRENT.

b. CONNECTION AND LINE-UP OF SIGNAL LINES. After the relay unit and switchboard are prepared for use, the signal line to the TWX station is connected. For one-wire operation the line conductor

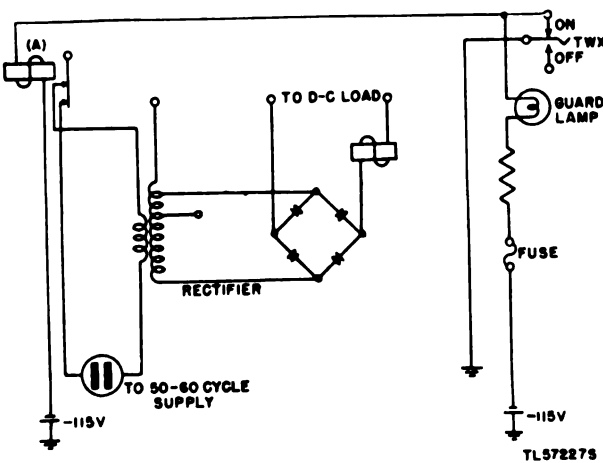

Figure 183. Guard lamp and rectifier input circuits of Relay Unit BE-84-A.

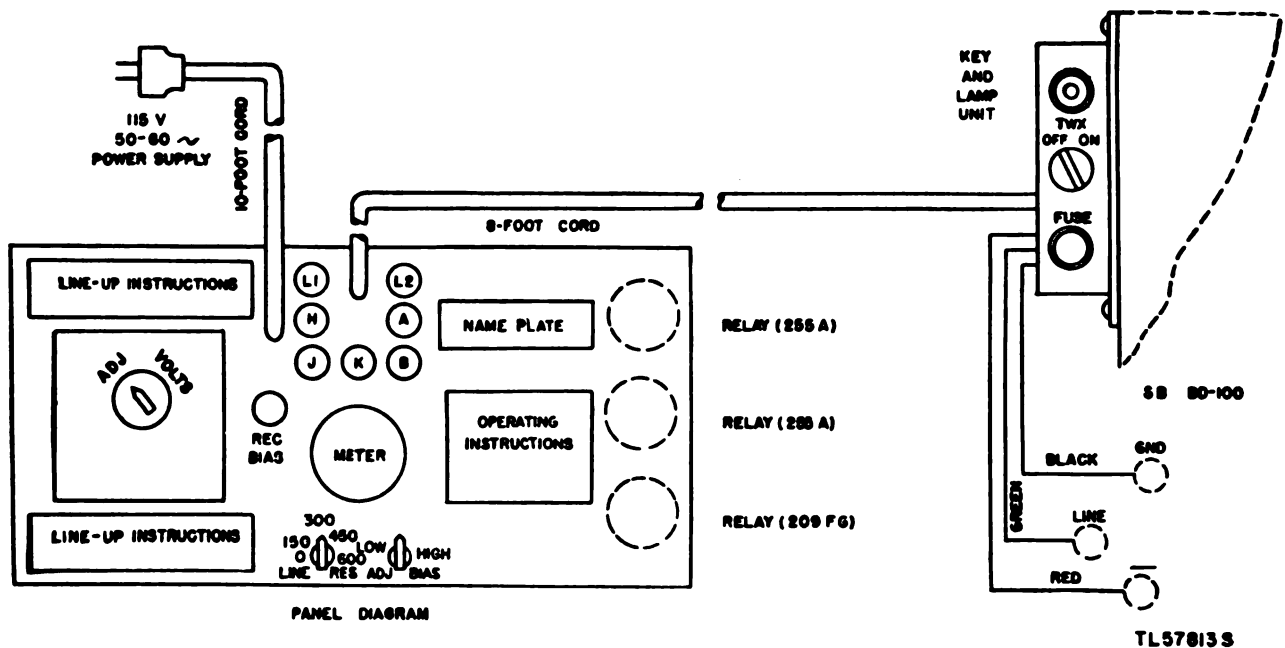

Figure 184. Panel diagram with cording connections.

is connected to terminal L2, terminal A strapped to B, and terminals J and K strapped. Terminals J and H should not be strapped for one-wire operation. Only one strap is necessary for the two-wire operation (between terminals J and H). The signal line is connected to L1 terminal and the neutralizing line to terminal L2 when operation is two-wire. Line connections for both one-wire and two-wire operations are shown in figure 185. Before power is connected to the relay unit, the ADJ BIAS knob of the unit should be turned to the HIGH position and the LINE RES knob turned to 300. This enables the operator of Switchboard BD-100 to send to the TWX operator when the unit is turned on, even though impulses cannot be received from the TWX station. The power to which the relay unit is connected, must be 110- to 120-volts 50- to 60-cycle alternating current. When power is connected, turn the TWX key on and adjust the voltage of the relay unit rectified by the ADJ VOLTS knob to 75 volts (red line on meter scale). Turning the TWX key to ON will signal the TWX operator whose answer will be indicated by needle vibration on the relay unit meter. When an answer is indicated, "This is Army switchboard calling testboard" should be typed and after the call is acknowledged (indicated by the meter vibration), space repeat signals are requested by typing, "This is Army switchboard. Send repeat space signals, for line-up." The relay unit can then be biased by depressing the REC

BIAS button and turning the ADJ BIAS knob until the meter of the relay unit indicates zero bias. The line relay of the switchboard is biased on these same space repeat signals. The value of line resistance may be determined by requesting the information from the TWX attendant. If this resistance is not 300 ohms, the LINE RES knob should be adjusted to the value given. When readjustment is necessary, the relay unit must again be lined up on space repeat signals. Transmission and supervision in both directions is checked before the teletypewriter equipment is turned over to operating personnel. The loop current may be changed somewhat upon instructions from the TWX attendant which will necessitate rebiasing the line relay of the teletypewriter switchboard.

c. OPERATION. To call or to answer a call, the operator's teletypewriter is connected to the loop circuit in the normal manner (answer key in) and the TWX key is turned to the ON position. When a recall of the TWX operator is necessary, the TWX key is moved to OFF momentarily (approximately 2 seconds). Break signals may be sent in the regular manner (operating the printer break key). Disconnecting is done by operating the TWX key to the OFF position and disconnecting the operator's teletypewriter (answer key out). A break signal in either direction will light the associated signal lamp of the Army switchboard. No connection is taken down until the connection has been

challenged to determine if both parties wish to discontinue the connection and to see that no other connection is desired. Operating instruction plates are attached to both the relay unit and the key and lamp unit. A facsimile of these instruction plates is shown in figure 186. If a later line-up check is

desired, the TWX switchboard is called and the testboard requested.

111. Maintenance

The only adjustment required to maintain service is that of the rectifier voltage output in case of an abnormal change in the a-c supply voltage after the initial line-up. This supply may vary plus and minus 5 volts (110 to 120) without an appreciable effect on the performance of Relay Unit BE-84-A. Check the output voltage occasionally during the times when the relay unit is not actually in use. Keep the output voltage at 75 volts. The rectifier may be removed, if necessary, by turning the unit on its back and removing the four round-head screws on the top of the panel. When the relay unit is resting on its back, the position of the apparatus corresponds to the wiring diagram found on the inside of the bottom panel. Tools necessary for removing and replacing lamps are supplied with Switchboard BD-100. Care must be taken when replacing the fuse (located in the key and lamp unit) to insure that only a ¼-ampere fuse is used. Polar relay adjustments are given in the section of this manual covering tests. Normally the only maintenance necessary on the neutral relays is cleaning and burnishing the contacts. The contacts may be cleaned with carbon tetrachloride and burnished with a contact burnisher. Never use a file. All dirt and magnetic particles may be removed by applying a small piece of friction tape to the contacts. When a relay cover is removed, tap it before replacing it. Keeping the entire relay unit clean is the best assurance of properly operating relays.

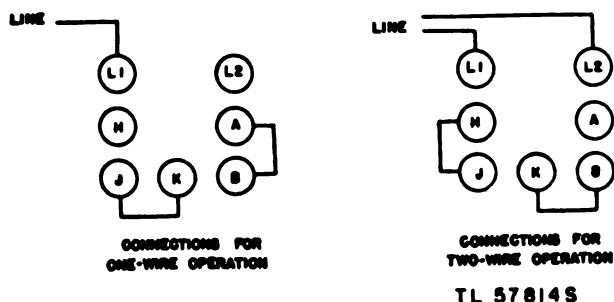

Figure 185. Line connections for Relay Unit BE-84-A.

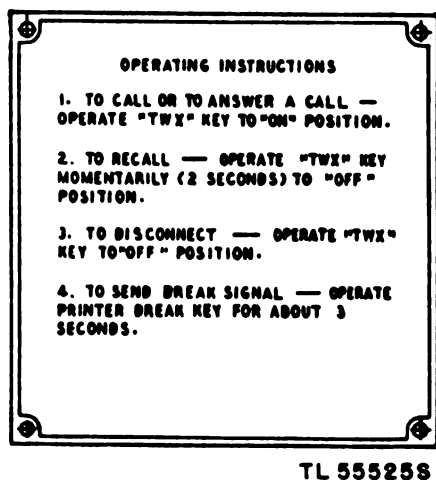

Figure 186. Facsimile of operating instructions.

CHAPTER 3

TEST SETS AND RECTIFIERS

Section I. USE OF TEST SETS

112. General Introduction

Various test sets are designed to test the functioning of teletypewriter equipment. The test sets covered here are the most common types and, for the most part, are designed to test receiving mechanisms, relays, bias meters, circuits, and transmitting mechanisms. The type CA-405-A test set is used for testing the adjustment of polar relays used with teletypewriter equipment and may also be used for testing the line, bias, magnet, and shunt circuits of teletypewriters. Test Set I-181 is a current-flow type relay adjusting set, particularly adapted for use with smaller installations of communication equipments where simplicity of operation and portability are important. Test Set I-193-A is used for testing polar relays and may also be used for lining up teletypewriter circuits. This latter use is generally in conjunction with carrier equipment and will not directly concern the teletypewriter mechanic. The ED-55-AJ type test set is used for checking the receiving mechanisms of teletypewriter equipment and for calibrating bias meters. This set may be substituted for the standard model 14 transmitter distributor. Test Set TS-2/TG is used for the same purpose as the ED-55-AJ type test set but is capable of sending various test signals without prepared tape. This set cannot be substituted for the standard transmitter distributor. Test Set TS-383/GG is used for testing transmitting and receiving mechanisms, testing individual signals, calibrating bias meters, and checking relays. In the field, other test sets may be available but their use is similar to those covered in this section.

113. Type CA-405-A Test Set

a. GENERAL. This test set may be considered as two distinct sets combined into one instrument and having the necessary controls to permit the selection of the respective tests applicable to each. A teletypewriter circuit test set and a polar relay test set are

two possible combinations. Figure 187 shows the type CA-405-A test set with its covers removed. Before type CA-405-A test set is placed in operation, certain calibrations are necessary to insure proper adjustment of the relays when the meters indicate the adjustments as satisfactory. Set each meter needle at 0 with no relay inserted and no power connected. Adjusting screws are provided on each meter for this purpose. For proper functioning of the test set, the D-C GALVANOMETER must show full-scale deflection when a relay with clean contacts is inserted into the mounting block of the test set; when the MEASURE CURRENT-RELAY TEST key is operated to the relay test position; when the key marked BIAS CONTACT TEST is operated to the bias position; and when the armature of the relay is held against one of the contacts. Adjust the meter to read to full scale (30) by the METER DEFLECTION rheostat. When full-scale deflection is not possible, replace the battery in the set. Make a check on the meter deflection each day the test set is to be used. The battery (ordinary flashlight cell) may be replaced by removing the plug to the eight-conductor cord at the rear and taking out the front panel. Refer to figure 187 for location of parts of the set. Figure 188 shows the circuit set up for a bias test, and figure 189 illustrates the circuit set up for contact tests.

b. CIRCUIT TESTS. When the individual circuits of a teletypewriter are to be tested, disconnect all power at the machine, remove the relay from the teletypewriter, insert it into the relay connecting block of the test set, and connect the eight-prong plug of the test set (fig. 189) in the relay connecting block of the machine. Direct current should be connected at the teletypewriter, and the MEASURE CURRENT-RELAY TEST key should be operated to MEASURE CURRENT. With the key in this position, it is possible to measure the current flowing in individual circuits of the teletypewriter by depressing the push-type keys of the test set. These keys are marked according to the circuits

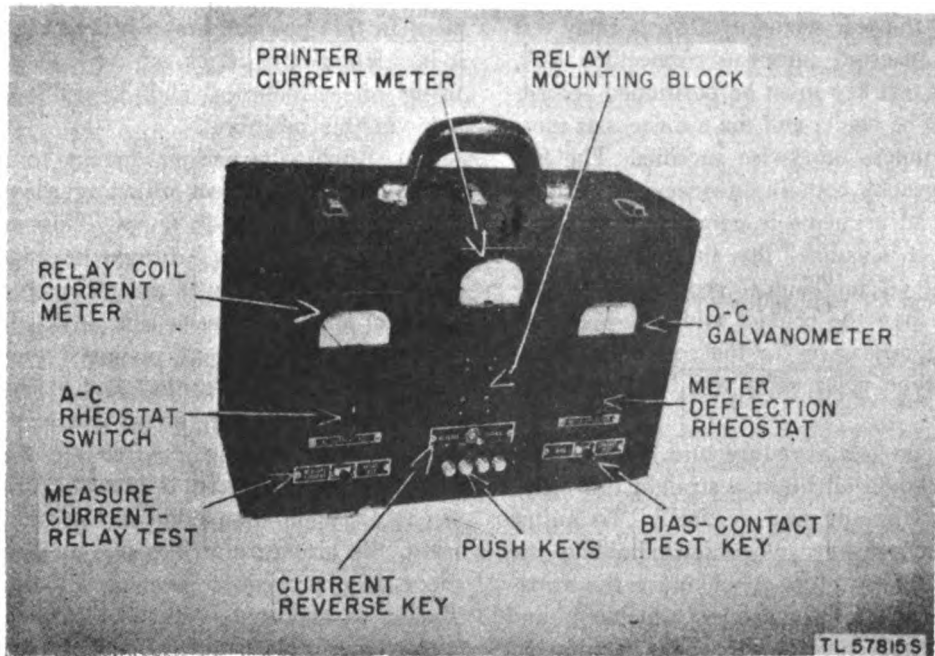

Figure 187. Type CA-405-A, front cover removed.

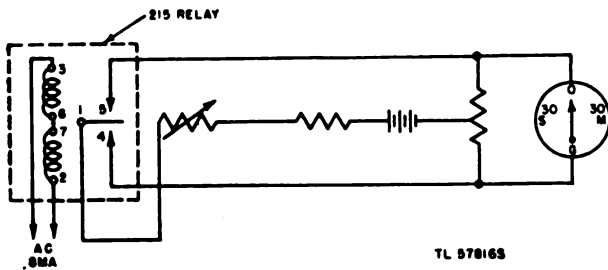

Figure 188. Circuit set up for bias test.

they control. In the event the meter deflection is reversed, the toggle switch located above the push keystrip should be operated to the opposite position; this action will reverse the connections to the meter.

c. **RELAY TEST.** (1) *General.* The relay test consists of checking the pole piece adjustment and the adjustment of the contacts. For each of these tests, turn the rheostat switch A-C CURRENT ADJ all the way counterclockwise (off), and connect a source of 115-volt, 25- to 60-cycle alternating current through the a-c cord and plug located at the rear of the test set. The MEASURE CURRENT-RELAY TEST key must be moved to the relay test position when either of the relay tests are made. The alternating current should always be turned off at the rheostat switch unless an actual bias or contact test is being made.

(2) *Bias test.* A bias test of the relay is made by turning the rheostat switch clockwise until the RELAY COIL CURRENT meter indicates 6 ma and

by operating the bias-contact test key to the bias position. The meter needle should oscillate at 0 for a well adjusted relay. However, the pole-piece adjustment can be considered satisfactory if the needle is oscillating within the limits of $\pm \frac{1}{2}$ scale division of 0.

(3) *Contact test.* For this test, all controlling keys, rheostats, etc., are kept in the same position as for the bias test with the exception of the bias-contact test key which is shifted to the contact test position. A well adjusted relay will have a meter deflection of seven or eight scale divisions to the right of 0. However, relay contacts that cause the meter to deflect to the right between 5 and 10 scale divisions may be considered satisfactorily adjusted.

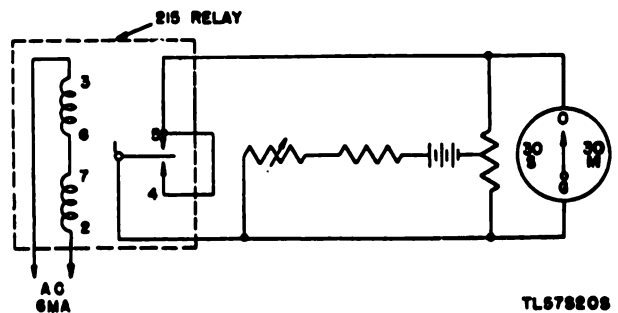

Figure 189. Circuit set up for contact test.

d. **ADJUSTMENT OF RELAYS.** The best adjustment of 215-type polar relays can be obtained when using the type CA-405-A test set or its equivalent.

Adjust all such relays with the test set whenever possible. Set up the test set as it is for a relay test with the relay inserted into the connector block. The bias-contact test key must be positioned according to the test to be made, and the a-c rheostat must be set at OFF unless otherwise specified. The following subparagraphs contain information pertaining to the relay adjustments in connection with this type of test set. It is assumed that the relay has been cleared and that all mechanical requirements have been met other than the contact and pole-piece adjustments. Tools necessary for the complete adjustment of a 215-type polar relay are in the rear of the cabinet.

(1) Contacts on the armature and those on the contact screws should all lie in a straight line when viewed both horizontally and vertically. To adjust the armature: loosen the two screws holding the armature at the back of the spool, move the armature as required to effect proper alignment, and tighten the two screws securely. The position of the contact screws can be adjusted by loosening the bracket mounting screws and adjusting the position as required. Make sure that all screws are tightened after the adjustment has been made.

(2) With the pole pieces backed off, release the armature by placing magnetic shunt (484-A tool) over the ends of the pole pieces. This allows the armature to assume a position free from any magnetic attraction. When the armature is released in this manner, it should assume a position in the center of the spool. Loosen the coil mounting screw and obtain the proper alignment by positioning the coil; then tighten the mounting screw.

(3) When the armature is properly aligned, leave the 484-A tool over the ends of the pole pieces and advance one of the contact screws until it just touches the armature. This will be indicated by a deflection of the d-c galvanometer needle.

(4) Back off the contact screw 0.002 inch (about $\frac{1}{2}$ turn) using the 0.002 gage. Before the gage is inserted, it should be cleaned with carbon tetrachloride and wiped with a clean cloth.

(5) Adjust the other contact in accordance with (3) and (4) above. The total armature travel will then be 0.004 inch and the armature should stand midway between the contact screw as gaged by eye.

(6) Remove the magnetic shunt.

e. POLE-PIECE ADJUSTMENT. (1) Turn the left-hand piece against the armature, pushing the armature contact over until it just touches the contact screw on the right-hand side. This will be indicated

by a deflection of the meter needle. Hold the pole piece in this position and advance the locknut until it is friction-tight. Back off the pole piece $\frac{1}{4}$ turn, using offset tommyes, and carefully lock the pole piece in this position.

(2) Apply alternating current to the relay by turning the a-c current-adjusting rheostat until the associated meter reads 6 ma. This will cause the armature to vibrate. Advance the right-hand pole piece until the needle of the galvanometer oscillates an equal amount on each side of 0. (In relays having comparatively weak magnets, the final adjustment may be rather critical and a slight movement of the pole piece may cause considerable variation in the meter reading.) After the right-hand pole piece has been adjusted, tighten the locknut securely.

(3) If, upon completion of the pole-piece adjustment, the armature strikes one or both of the pole pieces, the procedure given in (1) and (2) above should be repeated, with the left-hand pole piece retracted slightly more than $\frac{1}{4}$ turn.

f. FINAL CHECK. After both contact and pole-piece adjustments have been completed, give the relay a final test with the cover in place. If the meter needle deflects more than 10 scale divisions on the contact test, the contacts are not satisfactory. The condition may be due to dirty contacts, too great a contact separation, a defective armature, or a weak magnet. If the deflection is less than five scale divisions, the contact separation is too small and will result in short contact life. If the bias check shows the pole-piece adjustments to be off, the trouble may be in dirty pole pieces, especially from metallic particles or incorrect adjustments. If the contact reading is satisfactory and the bias reading does not exceed two scale divisions, the bias may be corrected by turning both contact screws slightly in the same direction. That is, the right-hand contact may be advanced and the left-hand contact retracted equal amounts, or vice versa. This necessitates another contact test.

114. Test Set I-181

a. Figure 190 shows Test Set I-181 with its cover removed. The primary function of this current-flow test set is to measure and control the amount of current flow through the winding of a relay, drop, or similar electromagnetic apparatus which is being tested or adjusted. This test set also may be used as a d-c milliammeter over three meter scale ranges of 0-15 ma, 0-75 ma, and 0-150 ma.

b. Use of the test set for measuring the values

of current applied to the windings of relays and similar electrical apparatus, for testing and adjusting purposes, involves the connection of the test set at a particular point in the electrical apparatus under test. It also involves connecting to the test set in a particular way and, usually, connecting battery or ground supply to the test set. It may require preliminary preparation, such as the blocking of other relays operated or nonoperated, closing or opening particular contacts in the circuit under test. This type of information is usually found in technical manuals covering the equipment to be tested, together with current values on which each relay (or similar apparatus) is to be checked for proper performance and the values to which the equipment must be readjusted.

c. TM 11-2036 contains detailed information on Test Set I-181.

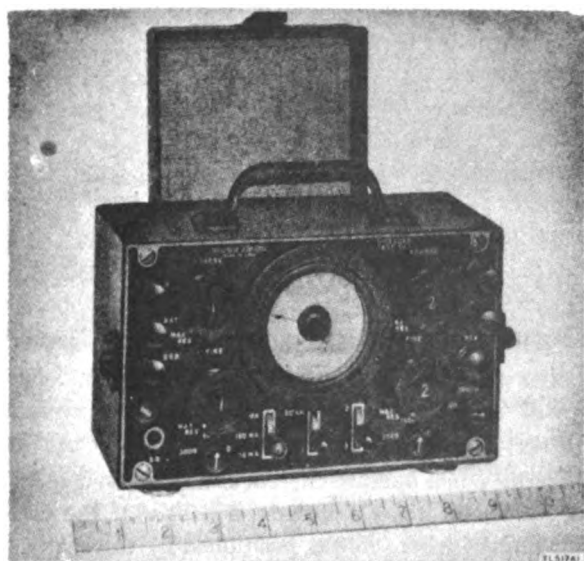

Figure 190. Test Set I-181, cover removed.

115. Test Set I-193-A

a. **GENERAL.** Test Set I-193-A, like the type CA-405-A test set, provides a means of testing and adjusting polar relays of the WECO 215 type. A connecting block for another type polar relay is also included, permitting the set to be used with carrier equipment. The set uses direct current for operational power but contains a system whereby this direct current can be converted into 20-cycle alternating current for the adjustment and testing of polar relays. Another system is included for the production of signal impulses, allowing the set to be used for lining up teletypewriter circuits. This

latter use is employed with carrier equipment and will not directly concern the teletypewriter mechanic. Test Set I-193-A is a compact portable unit assembled in a plywood carrying case with a hinged cover. (See fig. 191.) Compartments are supplied in the unit housing for spare relays (not included with the set), relays that are used in the set itself, tools necessary for the adjustment of polar relays, blown-fuse indicators and fuses, and a technical manual. In addition, operational instructions are attached inside the cover. The relay test is practically the same as is made with the CA-405-A test set except that OPERATE and NONOPERATE current is used to check the sensitivity of the relay. Operate current is the lowest value of current that will cause the relay to operate its armature; nonoperate current is the highest value of current at which the relay armature will not be operated.

b. **RELAY TESTS.** (1) *General.* The relay test portion of Test Set I-193-A consists of the necessary meter, lever-type telephone keys, and relay connector block. All of these are connected electrically so that the electrical operating characteristics of a polar relay can be determined by means of meter needle deflections. There are two types of operating tests which are referred to as bias and sensitivity tests. All circuits associated with relay testing are set by fixed resistors and are, therefore, not adjustable. The meter indications given in the following paragraphs are on the assumption that the power supply is 130 volts of direct current. If the power supply is less, the meter indications will be correspondingly smaller.

(2) *Bias test.* The relay bias test used with Test Set I-193-A is the same as that with the type CA-405-A test set, that is, a reversal of current through the relay windings causes the armature to oscillate from one contact to the other. This, in turn, causes a reversal of current through the meter. If the relay is in correct adjustment, the meter needle will oscillate at zero. The pole pieces are considered out of adjustment when the oscillation point is more than one-half of one scale division to the right or left of zero.

(3) *Sensitivity test.* The bias test is used to determine whether the pole pieces are at equal distance from the relay armature. However, the pole pieces may be at equal distances from the relay armature and still be out of adjustment, causing the relay's sensitivity to be affected. The sensitivity test is used to determine whether the clearance from each pole piece to the relay armature is correct and at the same

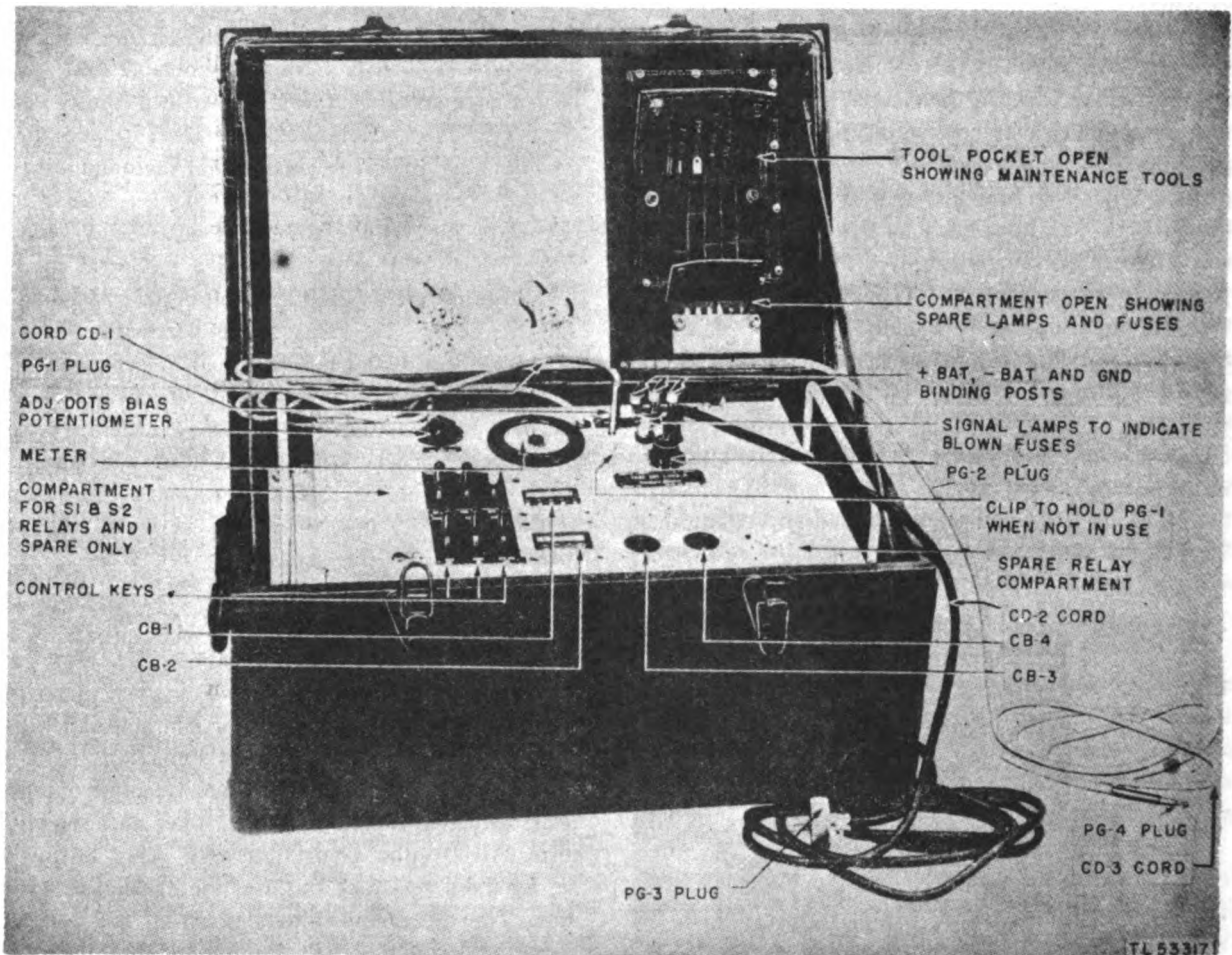

Figure 191. Test Set I-193-A in carrying case.

time is a check on the contact adjustment. Operate and nonoperate current values are applied to the relay windings on both the marking and spacing directions to make this test. Before operate or nonoperate current is applied to the relay windings, soak current is applied. Soak current is greater in value than the usual operating current and is applied in the opposite direction to the operate and nonoperate currents. By applying this current to the windings before the operate and nonoperate tests are made, the same magnetic condition is made to exist prior to each test. Soak current is automatically connected when operate or nonoperate current is removed from the relay windings and is automatically disconnected when they are applied. The armature of a correctly adjusted relay is caused to move to the spacing contact when operate current is applied in a spacing direction. This connects battery to the test set meter in a manner to cause it to indicate 100 to the left

of zero. When operate current is applied in a spacing direction, the relay armature will stay at the marking contact where it was positioned by the soak current and the meter will indicate 100 to the right of zero. This operation is shown in a simplified form in figure 192. The meter readings, armature movements, and all batteries are reversed when relay sensitivity is being tested on marking current.

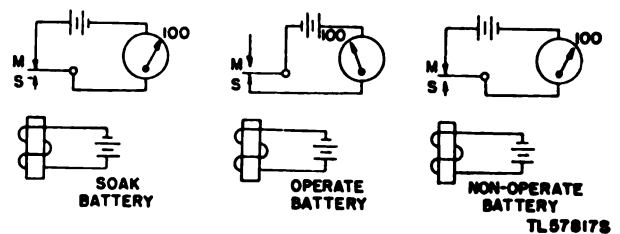

Figure 192. Operation of test set on sensitivity test (spacing current).

116. Use of Test Set I-193-A

Place Test Set I-193-A as close as possible to the power supply which may be any source of 115-130 volts direct current. Connect the ground terminal of the test set to ground *unless the positive side of the power source is grounded*. If the positive side of the power source is grounded and an earth connection is made at the test set, a direct short will result. The two polar relays used in the test set must be in good adjustment for proper operation. Four connecting blocks are incorporated for the connection of two types of polar relays (one regular and one tube-type socket for each). These blocks are controlled by a key (K4). When this key is positioned at CBI-CB3, only the connecting blocks used for a three-winding polar relay (used in carrier and repeater equipment) are connected in the circuit. The two-winding polar relay (215 type) sockets are connected in the circuit by having key K4 positioned at CB2-CB4. The current values given in the following subparagraphs are on the assumption that the test set is connected to a d-c packaged repeater or other source of 130 volts direct current.

a. CONNECTION OF POWER. A Telegraph Repeater TG-30, if available, is a very good means of obtaining power for operation of Test Set I-193-A. A test set jack is incorporated in the repeater which is connected to the rectifier output leads. No interference in signal line operation is caused by this power connection at the repeater. The line switch, however, must be at position 2 (negative battery grounded). The test set is connected at the repeater jack by the gray plug and associated cord, the other end of which terminates in three pin terminals for connection to battery and ground binding posts of the test set. Connect the white conductor to the positive battery terminal, blue conductor to the negative terminal, and the red conductor to the ground terminal. The red plug of the test set must be inserted into the J1 jack for completion of the power circuit. The power cord supplied with the test set may be used if the power source is to be a rectifier or power unit. A midget base receptacle is incorporated for this type connection. Do not ground the rectifier or power unit or use them with any other equipment while they are used with the test set. The ground lead connected at the test set will effectively ground the negative side of the power supply. A test of polarity is necessary with the use of this type power source and can be accomplished by throwing key K5 to the SEND DOTS position and connecting the red plug of the test set to the

J1 jack. The plug at the power source can be reversed if the meter needle is deflected to the right. Key K5 should be restored to its normal position as soon as the polarity test is completed. Test Set I-193-A is connected to telegraph equipment other than Repeaters TG-30 or TG-31 by the red plug of the test set and the jack designated on the telegraph equipment.

b. A-C CHECK. After the power supply is connected, check the test set for 20-cycle alternating current. This can be done by throwing key K6 to the DOTS HIGH position with all other keys normal. The key should be moved to midposition and back to DOTS HIGH again if the meter needle fails to oscillate near zero. In case the needle still does not oscillate near zero, relay S1 should be removed from the test set and replaced by a like relay that is known to be in good adjustment.

c. BIAS TEST. Place the relay to be tested in the corresponding connector block and move the associated key to its proper position. By moving key K6 to the DOTS HIGH position, key K5 to the TST RELAY position, and key K1 to the BIAS position, alternating current will be produced and connected to the relay windings. This will cause the armature of the relay under test to oscillate from one contact to the other and with key K5 arranged for relay test, the contacts of the relay will be connected to the meter. The meter needle will be made to oscillate when the armature is vibrating from one contact to the other because the two contacts have opposite battery connected. The pole pieces are out of adjustment when the oscillation point is more than one-half of one scale division to the right or left of zero.

d. SENSITIVITY TEST. (1) *General.* The sensitivity test is made with the same power and relay connections as are used for the bias test. Some key arrangements are changed. Key K1 is moved to the sensitivity position and keys K2 and K3 are arranged according to the following subparagraphs.

(2) *Key K2 positioned at space and key K3 normal.* This operation applies soak current in a marking direction and the armature should be on the marking contact, causing the meter to indicate 100 to the right of zero.

(3) *Key K3 positioned at OPERATE.* This operation disconnects the soak current and connects operating current in a spacing direction. The armature should move to the spacing contact, causing the meter to indicate 100 to the left of zero.

(4) *Key K3 positioned at NONOPERATE.* This operation removes the current in a spacing direction,

momentarily applies soak current again (causing the armature to move to the marking contact), and applies current in a spacing direction that is not sufficient to cause the armature to move to the space contact if the relay is in correct adjustment. The armature should remain on mark and the meter should indicate 100 to the right of zero.

(5) *Key K2 positioned at mark and key K3 normal.* This operation applies soak current in a spacing direction and the armature should be on the space contact, causing the meter to indicate 100 to the left of zero.

(6) *Key K3 positioned at operate.* This operation disconnects soak current and connects operating current in a marking direction. The armature should move to the mark contact, causing the meter to indicate 100 to the right of zero.

(7) *Key K3 positioned at nonoperate.* This operation removes the current in a marking direction, momentarily applies soak current again (causing the armature to move to the space contact), and applies current in a marking direction that is not sufficient to cause the armature to move to the mark contact if the relay is properly adjusted. The armature should remain on the space contact and the meter should indicate 100 to the left of zero.

117. Adjustment of Relay

Power and relay connections for the adjustment of relays are the same as for testing. All keys should be at their normal (middle) position except key K5 which should be arranged for relay test. This will connect the contacts of the relay to be tested to the meter, causing the meter to show an indication when the armature is against either contact. The pole pieces should be backed off as far as possible and the contact screws backed off until there is an observable clearance between the armature contacts and the contact screws. The following procedure is given with the assumption that all mechanical requirements such as cleaning, contact alignment, armature clearances, etc., have been met. The meter indications given are those obtained when the power supply is a d-c repeater (packaged) or other 130-volt source.

a. CONTACT ADJUSTMENTS. (1) Advance the right-hand contact screw until the meter deflection to the right indicates the contact screw just touches the armature. Back off the right-hand screw for a distance equal to one-third of the angle between adjacent holes in the contact screw.

(2) Follow the same procedure with the left-

hand contact screw; in this case the meter needle will be deflected to the left of zero.

(3) Check for armature travel limits of 0.003 inch to 0.005 inch with the No. 74D gage. Before using the blades, clean them with a clean, lintless cloth moistened with clean solvent such as carbon tetrachloride. Do not touch the blades before using them. Hold the armature lightly against one contact and check the gap between the armature and the other stationary contact. The 0.003-inch blade should pass through the contact gap easily and the 0.005-inch blade should pass through with pressure. Check the gap on the other side of the armature in the same manner.

(4) Repeat the entire procedure if the check of the armature travel limits is more or less than 0.003-0.005 inch.

b. POLE-PIECE ADJUSTMENTS. (1) Using the No. 340 tool, advance the right-hand pole-piece screw until it is near the armature.

(2) Tighten the tension nut on the pole-piece screw with the fingers until a noticeable increase in force is required to move the pole-piece screw.

(3) Continue to advance the right-hand pole-piece screw until it touches and moves the armature far enough to cause the armature to close the left-hand contact, as indicated by the meter needle deflection to the left of zero.

(4) Back off the right-hand pole-piece screw more than one-quarter turn and less than one-half turn.

(5) Advance the left-hand pole-piece screw until it is near the armature and tighten the tension nut the same way as with the right-hand pole-piece screw.

(6) Throw key K6 to DOTS HIGH position and key K1 to BIAS position. Advance or retract the left-hand pole-piece screw until the meter needle oscillates at zero.

(7) Apply the complete sensitivity test as outlined in paragraph 116 *d* above.

(8) If the operate test portions of the sensitivity test fail, the relay must be made more sensitive. That is, it must be made to operate on less current. To accomplish this, throw key K1 to BIAS and turn the right-hand pole-piece screw away from the armature until the meter needle oscillates at about one-half scale division to the left of zero. Then retract the left-hand pole-piece screw until the meter needle oscillates at zero. Continue this procedure until the operate requirements are met, then repeat the entire sensitivity test.

(9) If the nonoperate test portions of the sensi-

tivity test fail, the relay must be made less sensitive. That is, it must be made to require more current to operate. To accomplish this, throw key K1 to BIAS and turn the right-hand pole-piece screw toward the armature until the meter oscillates about one-half of a scale division to the right of zero. Then turn the left-hand pole-piece screw until the meter needle oscillates at zero. Continue this procedure until the nonoperate requirements are met, then repeat the entire sensitivity test.

(10) If both the operate and nonoperate tests fail, the pole pieces are too far from the armature. To correct this situation, proceed as outlined in (9) above of this procedure until the requirements are met.

118. Type ED-55-AJ Test Set

Type ED-55-AJ test set is a motor-drive mechanism to transmit signals that are distorted. It is used mainly for the purpose of determining the efficiency of selector units on teletypewriter equipment and regenerative repeaters, and for calibrating bias meters. It also may transmit normal, undistorted signals and is interchangeable with the standard transmitter distributor (model 14). Perforated tape must be prepared with the combination of signals desired for the operation of the test set. The ED-55-AJ set is very much like the model 14 transmitter distributor in both appearance and operation except that additional commutator rings and brushes are used to obtain controlled signal distortion. When used for normal transmission, only two of the commutator rings and one pair of brushes are used. Both pairs of rings and brushes are used for the transmission of distorted signals by making various combinations of electrical connections between the segments of the commutator rings and brushes. This is done by using a movable outside commutator ring and a switch that is plainly marked for the type distortion desired. A radio frequency filter incorporated in the test set is provided with a switch to enable disconnection of the filter when the set is being calibrated or when certain tests are made. Because the test set is so similar to the model 14 transmitter distributor, it is not necessary that adjustments and maintenance practices be covered in this section. It should be remembered, however, that the type ED-55-AJ test set is designed to test the efficiency of the receiving units and bias meters, making it imperative that all mechanical requirements are met and that the unit is kept free from all foreign materials. This latter is especially

true of the commutator rings. Figure 193 is an illustration of the type ED-55-AJ test set with cover removed. The contacts on the side of the unit are associated with the distortion control switch.

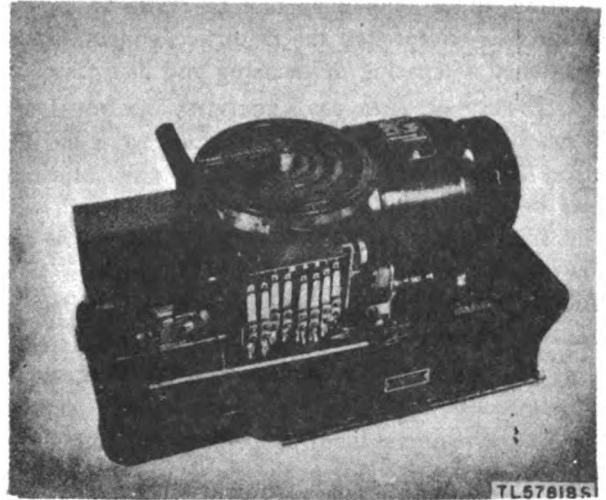

Figure 193. Type ED-55-AJ test set with cover removed.

a. **BIAS DISTORTION.** Bias is one form of distortion that may be transmitted by the type ED-55-AJ test set. In this case bias is not the effect of line characteristics but is caused by mechanical means (connection and arrangement of commutator rings and brushes). The waveshape transmitted by the test set arranged for bias distortion is square. The signals are affected by adding to or subtracting from the front of the marking signals. The amount of distortion to be transmitted is determined by the position of the outside commutator ring. Arrangement of this ring is accomplished by manually turning the ring according to the amount of distortion desired. A scale is mounted on the bracket supporting the movable ring which, in conjunction with a pointer, indicates the amount of distortion for which the test set is arranged. Marking or spacing bias is selected by a distortion control switch located at the front of the unit which controls the electrical connection of the commutator rings and brushes.

b. **END DISTORTION.** End distortion is a form of distortion that does not usually occur because of line conditions or characteristics. End distortion affects the length of the marking signals in much the same way as bias but instead of affecting the front of the signal, it adds to or subtracts from the rear of the marking impulse. The test set is arranged to produce this type distortion to enable determination of the quality of teletypewriter and regenerative

repeater receiving units by using signals containing marking and spacing bias and signals containing marking and spacing end distortion. The start and stop signals are unaffected when the signals transmitted are distorted by end distortion. The test set is arranged for end distortion the same way as it is for bias except that the distortion control key is positioned at spacing or marking end distortion.

c. EFFECT OF BIAS ON RECEIVING MECHANISMS.

It has been proved that bias distortion has a definite effect on the range of the receiving unit. Marking bias decreases the range by lowering the high side and spacing bias decreases the range by raising the low side. If the effect of bias distortion is fully understood, no trouble should be encountered in understanding the effect of end distortion.

d. EFFECT OF END DISTORTION ON RECEIVING MECHANISMS. The receiving mechanism of a teletypewriter requires about 20 percent of a signal for correct operation. When the receiving mechanism is oriented correctly, the 20 percent will be taken from the center of each impulse, thereby allowing the selecting interval to be shifted an equal amount in either direction. That is, the range finger may be moved toward the high and low ends by the same amount without causing errors in the printed copy. When end distortion is present in the received signals, the start and stop signals are not distorted. Therefore, any increase or decrease in length of the received marking impulse will be at the rear of that signal. This will affect the range of the receiving apparatus just opposite to the effect caused by bias distortion. Figure 194 is a comparison of the impulses of character Y as received with zero distortion, 40 percent marking end distortion, and 40 percent spacing end distortion. The selecting interval of each impulse is also shown. The selecting interval of A in figure 194 (zero distortion) may be moved 40 percent in either direction without the selection of a wrong impulse. The selecting interval of B in figure 194 (marking end distortion) cannot be moved to the left (low side of the range finder scale) without the selection of a marking impulse where space is required for correct reproduction of the character. The selecting interval may be moved to the right (high side of the range finder scale) by 40 percent with no effect on the selection of each impulse. The effect of spacing end distortion (C of fig. 194) is just opposite. That is, the selecting interval may be moved to the left by 40 percent without affecting the receiving unit but may not be moved to the right and still have the correct character reproduced.

Marking end distortion, then, causes the range of the receiving unit to be decreased by increasing the low side, and spacing end distortion decreases the range by decreasing the high side.

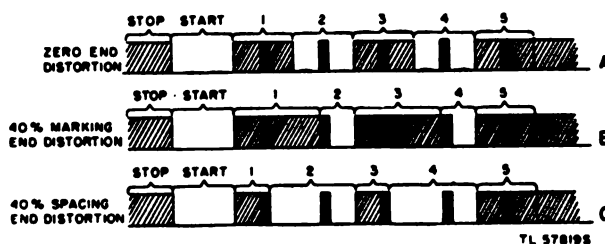

Figure 194. Comparison of received signals with zero and 40 percent end distortion.

e. INTERNAL BIAS. Internal bias is mechanical distortion caused by maladjustment of the receiving mechanism. Actually, these mechanical maladjustments have no effect on the received waveshape itself. They do, however, have an effect on the range of the equipment that is equivalent to causing the marking impulse to become greater or less in length on either the front or the rear. For example, if a selector unit has its magnets set too far from the armature, a greater than normal length of time will be consumed in pulling the armature to the marking position. The armature would be pulled to the spacing position at approximately the normal time because the tension of the armature spring will be normal. The net effect is equivalent to spacing bias distortion in the received signal. On the other hand, if the magnets set too close to the armature, the armature would be pulled to the marking position almost normally but would not release at the correct time because of the magnetism present in the magnets when the current through the coils is collapsing. In fact, the armature may be set so close to the magnets that it will not be released at all unless an anti-freeze strip is used on the armature. However, setting the magnets as close as that to the armature will not have a great effect on the armature moving from the spacing position to the marking position. The net effect, in the case of setting the magnets too close, will be equivalent to marking end distortion. (The selector magnets adjustment is but one of several adjustments that may cause internal bias.) Since bias and end distortion have opposite effects on the range of the selector unit, they may be used to determine the amount and kind of internal bias. This would be a test to determine the accuracy of mechanical adjustments. To accomplish this, the selector unit is first oriented on signals

containing marking bias and signals containing spacing bias. Then it is oriented on signals containing marking end distortion and signals containing spacing end distortion of the same amount. The difference between the orientation points on the range finder scale is the total amount of internal bias. The two orientation points will be the same on a perfectly adjusted selector unit. However, the unit is considered to be in adjustment when the total amount of internal bias does not exceed six points. The selector unit will tolerate the maximum amount of distortion of the type usually experienced on teletypewriter circuits when the range finder is set at the orientation point for marking and spacing bias.

119. Use of Type ED-55-AJ Test Set

a. GENERAL. The type ED-55-AJ test set is normally located at some central position in a teletypewriter installation in conjunction with a jack box or other means of connection to the signal lines of the equipment at that installation. In this way, the test set may be used to test any equipment at the installation simply by connecting the signal line of the test set into the signal line of the equipment to be tested. The connection of the test set signal line and power leads is identical to that of the standard transmitter distributor and the correct amount of line current must be supplied at the machine. The type ED-55-AJ test set may be substituted for a standard transmitter distributor when it is not needed for testing purposes and may be located as a part of the model 19 composite set. It is normally equipped with a synchronous motor and is, therefore, for use with 60-cycle alternating current only. A governed motor may be substituted but it is very important that correct motor speed be maintained at all times; otherwise, improper amounts of distortion will result. Even with correct motor speed, the signals are not absolutely perfect because the speed of the motor varies to a small extent on account of the action of the motor governor. The following procedure outlining the method of testing teletypewriter selector units may be used for testing regenerator units of regenerative repeaters as well.

b. TEST OF TELETYPEWRITER SELECTOR UNITS.

(1) *General.* Type ED-55-AJ test set requires perforated tape for the transmission of signals desired (usually R or Y or both). After the signal line and power leads are connected and the tape inserted into the test set, the outside commutator ring is turned until the calibration pointer is at 35 on the

scale. This positions the outside segmented ring in relation to the inside segmented ring so that 35 percent distortion will be transmitted. (When the distortion control switch is positioned at zero, only the outside commutator ring and its associated solid ring are connected. Thus, zero distortion will be transmitted regardless of the position of the calibration pointer on the scale.)

(2) *Bias test.* To orient the selector unit correctly so that the teletypewriter will tolerate the maximum amount of distortion of the type that generally is found in teletypewriter circuits, the distortion control switch is set at marking bias and the test set start-stop switch turned on. This causes signals with 35 percent marking bias to be transmitted to the machine and the upper end of the range can be determined. The low end of the range can then be determined with the distortion control switch set at spacing bias. Midway between these two settings is the point at which the machine will tolerate the maximum amount of bias. A correctly adjusted selector unit tolerates approximately 40 percent bias (either marking or spacing). The maximum amount of bias the unit will withstand may be determined by use of the following formula.

$$\frac{\text{Maximum bias} - 35 \text{ plus } \frac{\text{Upper limit marking bias} - \text{Lower limit spacing bias}}{2}}{2}$$

(3) *End distortion test.* To orient the selector unit correctly so that the teletypewriter will tolerate the maximum amount of end distortion, the distortion control switch is set at marking end distortion and the low end of the range is determined. The upper end of the range is then determined with the distortion control switch set at spacing end distortion. Midway between the two range finder settings is the point at which the machine will tolerate the maximum amount of end distortion. A correctly adjusted machine will tolerate signals with approximately 35 percent marking of spacing end distortion. The maximum amount of end distortion the machine will withstand may be determined by use of the following formula:

$$\frac{\text{Maximum end distortion} - 35 \text{ plus } \frac{\text{Upper limit spacing end distortion} - \text{Lower limit marking end distortion}}{2}}{2}$$

(4) *Internal bias determination.* The internal bias of a receiving unit may be found by calculating the difference between the orientation point for bias and

the orientation point for end distortion. Should this difference be greater than six points, some maladjustment is present in the selector unit and it must be readjusted according to specifications set up for that particular unit. If the setting (orientation point) for bias is higher than the setting for end distortion, the internal bias is said to be negative. If the reverse is true, the internal bias is positive.

c. TEST OF BIAS METER. (1) *General*. A test and possible calibration of bias meters associated with Line Unit BE-77-A and Switchboard BD-100 is necessary to keep teletypewriter circuits operating at peak efficiency. Type ED-55-AJ test set may be used as a source of undistorted signals for these calibrations. When adjustment is made at the rheostat of the bias meter circuit, it is essential that the greatest possible care be used to insure correct adjustment. Otherwise, the efficiency of the teletypewriter circuits to which the equipment is connected may be seriously impaired.

(2) *Calibration of line unit bias meter*. It is not necessary that the meter be removed from the line unit for testing and calibrating. The line unit, however, must be removed from service. The signal line connections of the test set should be connected to alligator clips by two conductors that are long enough to reach the line unit relay mounting block when the line relay is removed. The alligator clips should be fastened securely to the center and top-center terminals of the relay connector block. This connects the commutator rings and brushes of the test set in series with the bias meter circuit of the line unit when the meter switch is at BIAS. Alternating current for operation of the test set motor is connected the same as with the standard transmitter distributor. It is necessary that the filter switch on the left-hand side of the test set be at OFF to insure transmission of perfect signals. Space repeat tape must be prepared by perforating equipment that is known to be in good adjustment and inserted into the test set in the regular manner. The following procedure outlines the steps necessary for the test and calibration of the bias meter incorporated in Line Unit BE-77-A.

(a) Connect the line unit to its regular d-c power source.

(b) Position the outside commutator ring so that the pointer is at zero.

(c) Turn the distortion control switch to zero position.

(d) Throw the start-stop switch to ON. The meter should indicate zero bias.

(e) In the event the meter does not indicate zero bias, the small rheostat located at the front of the line unit should be adjusted by removing the nut that forms a cap covering the rheostat adjusting screw and turning the adjusting screw with a screw driver until the meter shows zero bias.

(f) Securely tighten the cap on the rheostat to prevent the adjusting screw from being inadvertently turned.

(3) *Calibration of switchboard bias meter*. It is not necessary to remove the meter from the switchboard for testing and calibrating nor is it necessary that the switchboard be removed from service. The test set is connected to the bias meter circuit of the switchboard by connecting a two-conductor switchboard plug to the line terminals of the test set and inserting the plug into the bias meter jack of the switchboard with the meter switching key at BIAS. No d-c power for the test set is necessary. However, the switchboard must be connected to its regular source of direct current. The procedure for testing is the same as the procedure for testing the line unit meter. If the meter does not indicate zero bias, the rheostat located in the back of the switchboard must be adjusted until zero bias is obtained. This rheostat is the same as the one incorporated in the line unit.

120. Calibration of Type ED-55-AJ Test Set

When the brushes on the segmented rings are adjusted or replaced, or when the pointer mounted at the calibration scale has been removed, the adjustment of the pointer must be tested. A test set equipped with a visual means of checking the length of the signals is the best means of making this test. Test Set TS-383-GG is one of this type and is discussed in paragraph 124. It is necessary to cut out the filter of the ED-55-AJ test set when calibration is finished. If a visual type test set is not available, the ED-55-AJ set may be calibrated by using a teletypewriter or any means of indicating opens and closures. The following procedure outlines the steps necessary for calibration of the test set in conjunction with a teletypewriter and may be applied to other means as well.

a. Connect the test set to the teletypewriter in the same way as when testing the selector unit.

b. Loosen the adjustable distributor disk clamping screws and rotate the disk clockwise until the pointer is off the distortion indicating scale.

c. Insert the tape perforated with Y combination into the test set and place the distortion control switch at marking and distortion.

d. Momentarily hold the clutch magnet armature against the face of the magnet and rotate the brush arm slowly by manually turning the motor until the brush arm approaches the No. 5 segment of the stationary ring.

e. Continue this slow movement until the receiving magnets of the teletypewriter indicate current flow in the circuit.

f. Move the distortion control switch to spacing bias position; the selector magnets should indicate no current flow in the circuit.

g. With the switch in spacing bias position, turn the distributor disk ring counterclockwise until the magnets again just indicate current flow, then clamp in that position by means of the three ring-clamping screws.

h. Adjust the pointer to indicate zero at the distortion indicating scale. Tighten the pointer securely in that position to prevent the necessity of future readjustment.

121. Test Set TS-2/TG

a. GENERAL. Test Set TS-2/TG is a portable signal distortion test set that is similar to the ED-55-AJ set and is designed for testing teletypewriter and regenerative repeater selector units. It may be used for testing bias meters of Line Unit BE-77- (*) and Switchboard BD-100 and in some cases for testing teletypewriter circuits. This latter use, however, does not directly concern the teletypewriter mechanic. Distortion is obtained and controlled in the same manner as with the ED-55-AJ set, that is, by electrical connection of the brushes and commutator rings. The set is arranged to transmit continuously, without the necessity of tape preparation, the signal combinations R, Y, space repeat, and a test message (quick brown fox, etc.). The selection of these signal combinations is accomplished by means of a five-position switch which may also be used to short circuit the test set for transmission of a continual stop impulse. Test Set TS-2/TG is provided with a governed motor enabling it to be used in conjunction with British equipment, with American equipment that is to be used in conjunction with British equipment, and with American equipment that is to be used with British teleprinter apparatus. A stable wooden carrying case is provided for use in transporting. The case is a hinged door that allows access to the power lead, line plug and switch, and jack panel, thereby permitting operation of the test set without removing it from the case. The case is also provided with a compartment for spare parts such

as lamps, brushes, fuses, etc. The radio frequency filter that is incorporated with the test set may be disconnected by means of a switch when the test set is being calibrated. Just as in all other test sets, preventive maintenance is a very important factor in keeping the set in good operating condition. The commutator rings especially must be kept absolutely free from all foreign materials. The adjustments are not at all complicated and are, therefore, not covered here. Should readjustment become necessary, the specifications may be found in TM 11-2208. Lubrication specifications are also given in that manual. Test Set TS-2/TG, with carrying case removed and all principle parts designated, is shown in figure 195.

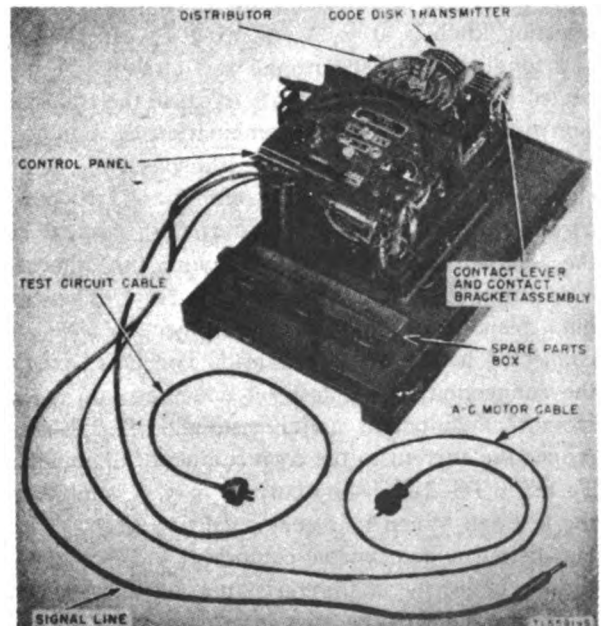

Figure 195. Test Set TS-2/TG with carrying case removed.

b. MECHANICAL OPERATION. The main shaft has two gears, the main shaft gear which meshes with the motor pinion and drives the main shaft, and main shaft pinion gear which, through the medium of the intermediate shaft and associated gears, drives the code disk cam shaft. On the code disk cam shaft are mounted cam disks that operate contact levers which, in turn, operate contact tongues similar to the contact tongues of the standard transmitter distributor. When the contact lever rides into an indent on its respective cam disk, the lower contact is closed by the contact tongue and a circuit is completed to the respective segments of the commutator rings. The circuit to the segments is not completed when the contact lever is held on the high

part of its cam disk as the contact tongue is against the upper contact which is not connected to the segment. The contact tongues are synchronized by gears that are driven by the main shaft, to open or close their contacts when the commutator brush is on the respective commutator segment. The main shaft also drives the brush arm. The cam disks are arranged to open and close the lower contacts by the contact tongues in a sequence that causes the test message to be transmitted. Transmission of all other signal combinations is caused electrically, that is, by connecting the proper segments directly to the signal line. Backlash of the code disk cam shaft is prevented by a friction assembly located at the end of the code disk cam shaft.

c. **ELECTRICAL OPERATIONS.** When the code-selecting knob is at R, Y, or space repeat, the contact tongues are disconnected and circuits are connected to the correct segments to cause the transmission of that character or combination of signals at which the knob is set. The transmission of that character or combination is continuous. Two power cords are provided, one for alternating current for the test set motor and lamp circuits, the other for connection to 115 volts of direct current. Two 800-ohm resistors and two series-connected jacks are connected to the d-c power lead. The jacks are for the connection of the test set line plug and a plug from the equipment under test, and two resistors reduce the current to the correct amount. Thus, with Test Set TS-2/TG, line current may be supplied at the test set. When it is connected to a line for testing distant teletypewriter equipment the local power cannot be used, as the resistance of the line plus the resistance of the two internal resistors would reduce the current to below the proper amount. Line current, in such case, is usually supplied at the equipment under test. Aid in checking and adjusting the motor speed is provided by an a-c lamp located just above the motor target beneath the small door on the switch and jack mounting panel. All power leads and connections are accessible without removing the test set from its carrying case. No clutch magnet is used; therefore, the brush arm will continue to rotate as long as the motor switch is on.

122. Use of Test Set TS-2/TG

Selector units and bias meters are tested with Test Set TS-2/TG in exactly the same manner as with the ED-55-AJ set except, of course, no tape is necessary and power may be supplied by the test

set. The combination of signals desired is selected simply by setting the code-selecting switch to the proper position. If a teletypewriter selector unit is to be tested, locate the test set near the teletypewriter and supply line current at the test set by inserting the machine's receive plug and the line plug of the test set into the two local jacks. The local jacks are not used and the line plug is connected directly to the line circuit when it is desired that test signals be sent to distant equipment. Under these circumstances, line current must be supplied at the distant equipment or at some other external source. Power should also be supplied at the equipment being tested when the bias meter is calibrated or checked. The outside commutator ring is positioned for the proper amount of distortion the same way as with the ED-55-AJ set and the same testing procedures are applicable. Correct motor speed is very important when testing selector units and bias meters because any deviation from correct speed will affect the length of the signals being transmitted. Check the motor speed and readjust if necessary just before each test is made. Allow time for the motor to warm up before checking its speed.

123. Calibration of Test Set TS-2/TG

When brushes on the segmented rings are re-adjusted or replaced, or when the pointer at the distortion scale has been moved, the adjustment of the pointer must be checked. An accurate calibration adjustment cannot be made with the visual type test set as the variation in speed caused by the motor governor allows variation in the signals as viewed at the other test set. Test Set TS-2/TG may, however, be tested and readjusted for correct signal distortion by the mechanical calibration adjustment outlined for the ED-55-AJ set, except that an external supply of power for the line circuit is not necessary as power can be obtained from the local jacks.

124. Test Set TS-383/GG

a. **GENERAL.** Test Set TS-383/GG is a motor-driven unit similar in operational features to Test Set TS-2/TG with the addition of a stroboscope. The stroboscope provides a means of visually checking the length of the impulses. A greater amount of distortion and a greater selection of signal combinations is possible with this test set than is possible with other distortion test sets. Controlled signal distortion is obtained by shifting the outer commutator ring which is geared to a control knob. The

amount of distortion is determined visually by means of the neon lamp stroboscope in conjunction with a calibration scale mounted on the front of the set. This calibration scale is movable and each impulse (segment) is marked off in percent so that each impulse can be checked individually. Generally, the best test set is equipped with a synchronous motor but a governed motor may be substituted. The latter motor is not entirely satisfactory for such use as calibrating other test sets because it causes the signals to waver somewhat. It does, however, have the advantage that it can be used with British equipment. Six commutator rings are used, four solid and two segmented. Two of the solid and both segmented rings are used for signal transmission and the remaining two are used in the stroboscope circuit. The brushes for the commutator rings are not the same type as used for other distortion test sets but the same function is performed. A metal cowl is supplied for cutting down the intensity of external light when the stroboscope is being viewed. Test Set TS-383/GG is illustrated in figures 196 and 197.

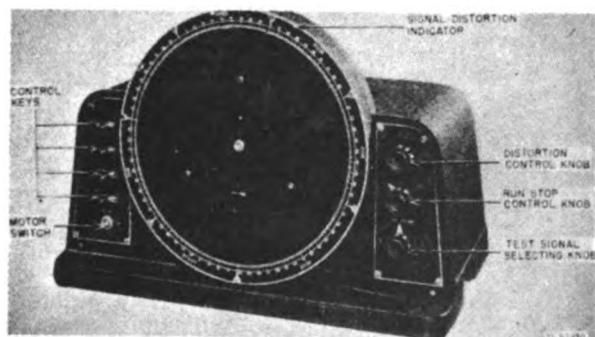

Figure 196. Test Set TS-383/GG.

b. MECHANICAL OPERATIONS. The main shaft, unlike Test Set TS-2/TG is horizontally mounted. (See fig. 197.) It has two gears, the main shaft gear which drives the main shaft, and the main shaft pinion gear which drives the code disk cam shaft through the medium of the intermediate shaft and associated gears. The brush arm is connected to the end of the main shaft and because the code disk shaft is mechanically connected to the main shaft, the brush arm is in synchronism with the code disk. A friction assembly located at the rear of the code disk applies a drag to the shaft, preventing backlash. The test set is equipped with contact levers and transmitting contacts instead of contact tongues as in Test Set TS-2/TG. These levers and contacts are similar to the transmitting contacts and levers of

the standard teletypewriter keyboard. The levers follow the cams of the code disks when a test message is being transmitted, causing the contacts to open and close in the correct sequence to transmit the test message. If a repeated R, Y, T, O, M, V, LETTERS, or BLANK combination is transmitted, the levers are cammed out of action with the code disks. These repeated combinations are obtained by setting the code-selecting knob to the desired indication. This knob, through cam action, opens and closes the five transmitting contacts to the correct combination. For example, when transmission of repeated LETTERS combination is desired, the code-selecting knob is set at LETTERS. This causes all five contacts to remain closed so that their respective segments will send marking impulses. If transmission of character Y is desired, the knob is positioned at Y. This will cam the second and fourth contacts open and will allow the other three to remain closed. The respective segments will then transmit corresponding impulses repeatedly until the knob is turned to some other combination or the motor is turned off. The only combination to be mechanically set up is the test message. All other combinations are set up electrically by manually causing the contacts to be opened or closed according to the combination desired.

c. ELECTRICAL CHARACTERISTICS. Four cords and plugs are provided with the test set for the connection of a-c power for the motor and d-c power for the stroboscope, for connection of the signal line, and for connecting the stroboscope to contacts of relay or regenerative repeater for testing the quality of the repeated signals. The latter two cords have plugs for connection to jacks. The d-c power for the stroboscope should be 110-115 volts and current for the signal line must be connected externally to the test set. The distributor brushes and segments complete connections between the transmitting contacts and the signal line. The two outer rings are segmented and are used for signal distortion in conjunction with two of the solid rings the same way as with the other distortion test sets. That is, the position of the outer segmented ring with respect to the inner one determines the amount of distortion to be transmitted. The inner pair of solid rings is used for the neon distortion indicator lamp. This neon lamp is mounted on the brush arm and may be viewed through a slit in the lamp holder arm. As the lamp revolves with the brush arm, it is lighted during marking impulses for the length of the marking segment. The signal lengths can then be viewed

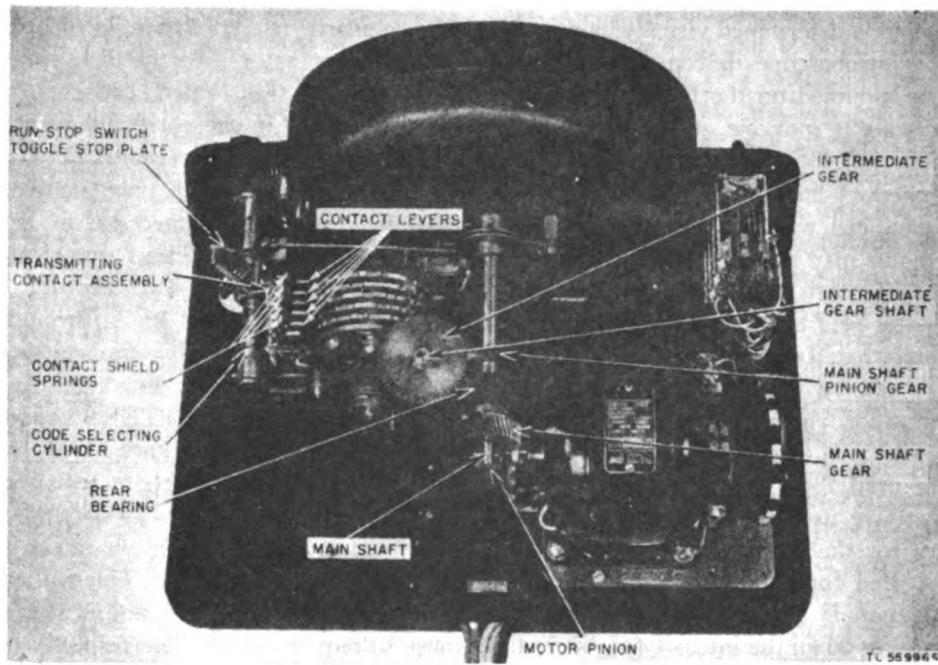

Figure 197. Test Set TS-383/GG (rear view).

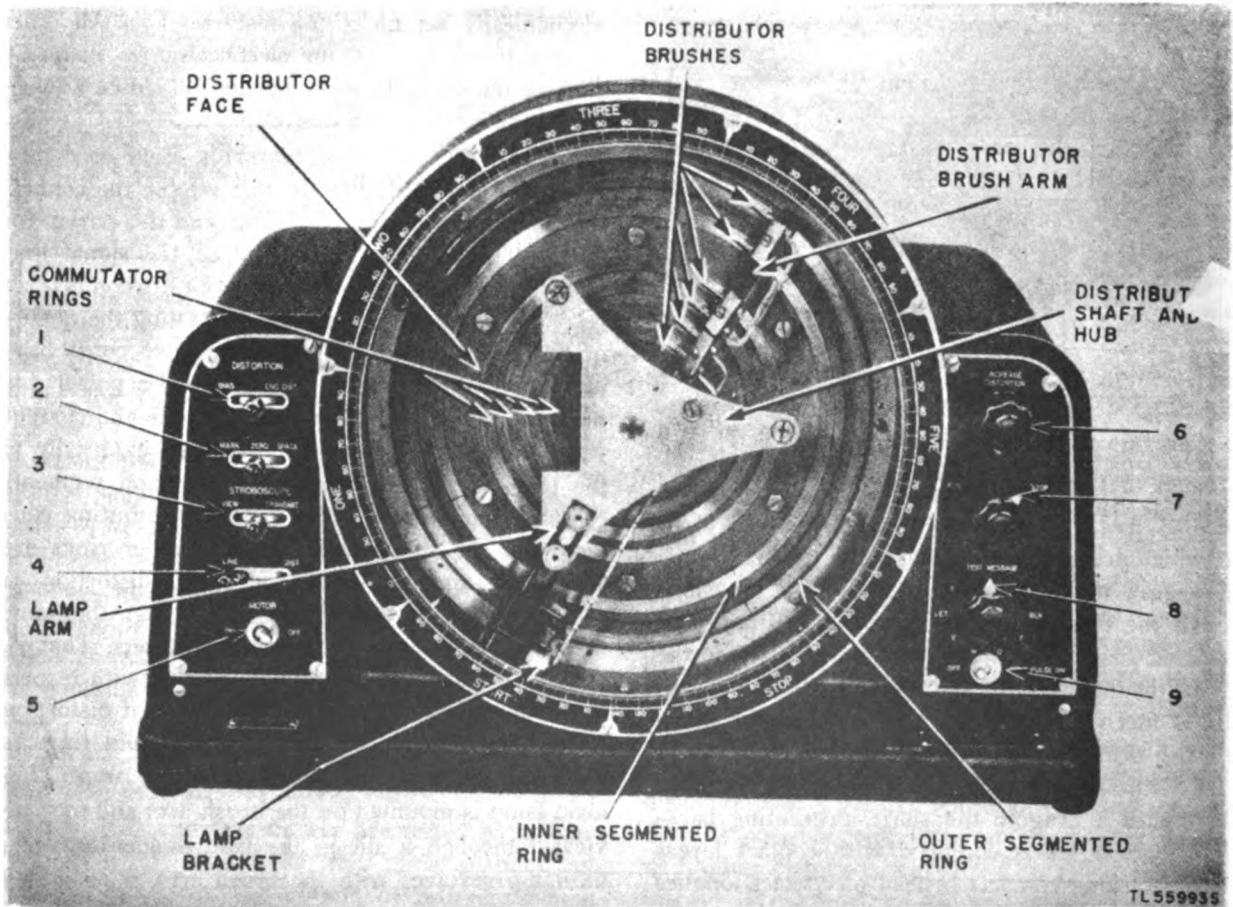

Figure 198. Control switches and knobs.

and calibrated in accordance with the calibration scale. This scale is movable, permitting it to be positioned according to the viewed signals. No means of stopping and starting the distributor is incorporated other than the motor switch. All control knobs and switches are on the front of the unit. The use of each switch or knob is given below and the location of each is given by number in figure 198.

- (1) For selecting bias or end distortion.
- (2) For selecting the type of transmission, marking or spacing distortion, or undistorted signals.
- (3) For connecting the transmitting commutator rings either to the stroboscope view or to the signal line transmit.
- (4) For connecting the neon lamp to the distributor for local calibration or to an external line for checking incoming signals.
- (5) For motor control.
- (6) For adjusting the amount of distortion to be transmitted.
- (7) For short-circuiting the outgoing line to keep the line circuit closed when the test set is being calibrated. When this knob is in the RUN position the short circuit is removed and the signals will be transmitted.
- (8) For selecting the signal combination to be transmitted: R, Y, T, O, M, V, LETTERS, BLANK, or the test message, THE QUICK BROWN FOX JUMPED OVER A LAZY DOG'S BACK 1234567890 DTS SENDING, followed by two carriage returns and one line feed. (DTS is furnished as the call letters of the station sending unless any other one, two, or three-letter word was specified at the factory.)
- (9) For disconnecting the stop impulse (segment). This permits transmitting a single marking impulse by setting the code-selecting knob (3) to the T position and turning this switch to off position. Earlier models were not equipped with this switch.

125. Use of Test Set TS-383/GG

It is not necessary to connect the cord with the black plug (stroboscope input) when testing selector units. This cord is used only when checking the quality of the signals transmitted by relays, repeaters, transmitter distributors, etc. For local calibration, the stroboscope power is obtained from the d-c cord. The a-c plug should be connected to a source of 110-115 volts alternating current and the d-c plug connected to a source of 110-115 volts of direct current. The red plug should be inserted into the signal line for transmission of test signals to the

unit to be tested. The procedure for testing selector units given for the ED-55-AJ test set should be followed for this test set as well. However, the amount of signal distortion must be determined by viewing the stroboscope lamp in conjunction with the movable calibration scale. When relays or repeaters are tested, the signals to the windings as well as repeated signals may be viewed. If a governed motor is used with the test set, it is essential that the motor speed be kept at the correct speed. Even when correct speed is maintained there is a slight wavering of the signals. In all tests it is necessary for the current in the signal line to be supplied externally.

a. RANGE DETERMINATION OF SELECTOR UNITS. With the keys and knobs set at the positions outlined in the following table, the stroboscope will indicate zero distortion of the signals; that is, the stroboscope lamp will light for 100 scale divisions on the graduated scale for each marking impulse and 142 scale divisions for the stop impulse. If necessary, the graduated calibration scale can be rotated until it coincides with the respective impulses. The receiving apparatus connected in the external signal circuit can then be checked for range with undistorted signals by rotating the RUN-STOP knob to the RUN position, the code-selecting knob to the TEST MESSAGE position, and placing the VIEW-TRANSMIT key in the TRANSMIT position. The signals cannot be viewed on the stroboscope when they are being transmitted. The signal line to the receiving unit will be open when the signals are viewed on the stroboscope unless the RUN-STOP knob is at stop position. Switch and knob positions for viewing undistorted signals are:

<i>Key or knob</i>	<i>Position</i>
Motor switch	ON
LINE-DIST key	DIST
VIEW-TRANSMIT key	VIEW
BIAS-END DIST key	CENTER
Code-selecting knob	R
RUN-STOP knob	STOP
MARK-ZERO-SPACE key	ZERO
STOP PULSE key	ON

b. BIAS TEST. For obtaining distorted signals of 35 percent marking bias, the keys and knobs should be positioned as shown in the tables in *a* above and in this subparagraph, and the DISTORTION CONTROL knob turned until the marking impulses each occupy 135 scale divisions. The signals will then be biased by 35 percent marking. Distorted signals can be transmitted by rotating the RUN-

STOP knob to the RUN position, the code-selecting knob to the TEST MESSAGE position, and placing the VIEW-TRANSMIT key in the TRANSMIT position. The 35 percent distortion can be changed to spacing bias by placing the MARK-ZERO-SPACE key at the space position. The correct orientation point for the range finder of the selector unit under test on signals containing bias distortion and the maximum amount of distortion the selector unit can withstand may be found by following the procedure given in paragraph 119b(2). The requirements are also given in that paragraph. Switch and knob positions for viewing signals with bias distortion are:

<i>Key or knob</i>	<i>Position</i>
MOTOR switch	ON
LINE-DIST key	DIST
VIEW-TRANSMIT key	VIEW
BIAS-END DIST. key	BIAS
Code-selecting knob	R
RUN-STOP knob	STOP
MARK-ZERO-SPACE key	MARK
STOP PULSE key	ON

c. **END DISTORTION TEST.** For obtaining distorted signals of 35 percent marking end distortion, the keys and knobs should be positioned as shown in the table in *e* below, with the exception of the BIAS-END DISTORTION KEY. This key should be set at END DIST. With the controls in this position, the signals may be viewed and the DISTORTION control knob should be turned until 35 percent distortion is indicated on the calibration scale. Distorted signals can then be transmitted by rotating the RUN-STOP knob to the RUN position and the code-selecting knob to the TEST MESSAGE position, and placing the VIEW-TRANSMIT key in the TRANSMIT position. The 35 percent distorted signals can be changed to spacing and distortion by shifting the MARK-ZERO-SPACE key to space. The correct orientation point for the range finder of the selector unit under test on signals containing end distortion and the maximum amount of end distortion the unit can withstand may be found by following the procedure given in paragraph 119b(2). Requirement specifications are also given in that paragraph.

d. **INTERNAL BIAS.** The internal bias of a receiving selector unit may be calculated by finding the difference between the orientation setting for bias distortion and the orientation point for end distortion. Internal bias should not exceed six points.

e. **TESTING RELAYS AND REPEATERS.** Relays or repeaters may be checked for faulty operation by comparing the signals obtained locally with signals after they have passed through the relays or repeaters. The signals transmitted by the test set will operate the relay or repeater and the relay or repeater contacts will make and break the circuit to the stroboscope lamp. The difference between the perfect local signal is the amount of distortion introduced by the repeating device. If a filter or protective capacitor is connected to the contacts of the apparatus under test, it must be disconnected; otherwise, an incorrect indication on the stroboscope may result. Power should be connected to the test set the same way as for other tests. The signal line should be connected to the windings and the stroboscope input plug (black) should be inserted in the circuit to the contacts of the apparatus to be tested. By setting the knobs and keys as indicated in the table below the input and output signals of the relay or repeater may be viewed and compared. The regenerative repeater is designed to receive signals with some distortion and retransmit these signals with zero distortion. It is, therefore, possible to test the regenerator unit of the repeater the same way as a selector unit of a teletypewriter is tested (35 percent distortion) by viewing the retransmitted signals. The regenerator unit should retransmit perfect signals on input signals containing as much as 40 percent bias distortion or 35 percent end distortion. The formula outlined for the ED-55-AJ set for calculating the amount of distortion the unit can withstand is also applicable to the regenerator units. Switch and knob positions for viewing relay input and output signals are:

<i>Key or knob</i>	<i>To view local signals</i>	<i>To view repeated signals</i>
Motor switch	ON	ON
LINE DIST key	DIST	LINE
VIEW-TRANSMIT key ...	VIEW	TRANSMIT
BIAS-END DIST key	Center	Center
Code-selecting knob	R or Y	R or Y
RUN-STOP knob	STOP	RUN
MARK-ZERO-SPACE key .	ZERO	ZERO
STOP PULSE switch	ON	ON

f. **CALIBRATION OF OTHER DISTORTION TEST SETS.** The adjustment of the calibration scale pointer on other distortion test sets may be accomplished by viewing the signals put out by the set under test. Test Set TS-383/GG should be connected as it is for testing relays or repeaters except the cord to the signal line need not be connected. All switches

and knobs should be positioned as outlined in the table immediately above under TO VIEW REPEATED. This will make it possible to view the signals put out by the set under test and, by moving the outside commutator ring of that test set, the signals can be made perfect (100 percent in length) as viewed on the calibration scale of Test Set TS-383/GG. The pointer on the calibration scale of the unit under test should then be placed at zero. The unit being tested should be set for either bias or end distortion because the movable commutator ring is the only one connected in the circuit when the test set is used for transmitting signals with zero distortion.

g. OTHER TESTS. Test Set TS-383/GG may be used with special circuits for a very accurate check on the adjustments of Relay BK-27-A. This test, however, necessitates the construction of special circuits and will not be covered in this text. If it is desired to test Relay BK-27-A with Test Set TS-383/GG, the necessary directions and specifications may be found in TM 11-358. Test Set TS-383/GG may also be used to test the transmitting contacts of teletypewriters. If this test is desired, the set should be connected to the transmitting contacts of the teletypewriter the same way as when it is connected to other distortion test sets for calibration and all keys, knobs, etc., should be at the same position. It is necessary to hold the selector magnets closed by hand in some mechanical way (such as turning the trip-off eccentric screw) to keep the machine running closed when the armature is in the spacing position. This is necessary because the stroboscope lamp presents an open to the line circuit. Each contact may be tested individually by sending repeated E, LINE FEED, SPACE, CARRIAGE RETURN, and T combinations from the teletypewriter. Any deviation from 100 percent in impulse length would, in all likelihood, be caused by maladjustment of the respective pair of contacts. The stop signal, of course, is an exception to this as it should be 142 percent in length. The repeated signal combinations may be sent by holding down the desired key and at the same time holding the space repeat rod against the intermediate pawl. The stop impulse cannot be eliminated from the stroboscope because the impulses received from the teletypewriter do not go through the segmented rings.

126. Maintenance of Test Set TS-383/GG

Adjustments and lubrication specifications for Test Set TS-383/GG are outlined in TM 11-2217.

Reference should be made to that manual before any mechanical adjustments are made.

Section II. RECTIFIERS

127. General Information

Rectifiers are used as a source of direct current in practically all teletypewriter installations. Although trouble seldom develops within the rectifiers, the teletypewriter mechanic may be called upon to adjust, repair, and maintain the various rectifiers that are components of teletypewriter sets. A rectifier is precisely defined as a device for converting alternating current into direct current without intervening steps. Generally, rectifiers are divided into two different types; dissimilar metal and vacuum tube. Each type depends for its operation upon the characteristic of permitting current to flow in one direction only. In order that the teletypewriter mechanic may be able to adjust, repair, and maintain rectifying equipment efficiently, it is necessary that he be familiar with the circuit diagrams, circuit operation, etc., of both types. With a few exceptions, no moving parts are included in rectifiers; the problem of properly maintaining them is therefore, largely dependent upon knowledge of the circuits and their operations. For the most part, these circuits are not difficult to understand. A rectifier may be made simply by connecting alternating current to a rectifying element and providing an outlet for the direct current. Other parts, such as capacitors, transformers, coils, resistors, etc., are merely refinements to obtain certain desired results.

128. Selenium Rectifiers

Certain combinations of thin films of metals permit electric current to flow in one direction much more easily than in the other. Two of these combinations possess these characteristics well enough to be utilized in rectifiers used with teletypewriter equipment. One combination is a thin film of copper oxide on a copper plate. The other is an especially prepared film of selenium oxide on a metallic plate such as iron. The resistance of selenium stacks in the forward or conducting direction is less than that of copper oxide, and, for that reason, the selenium stacks are somewhat more efficient. Actual operation of the two metallic-oxide rectifiers is similar.

129. Construction of Rectifying Elements

A complete rectifying element is formed by coating iron plates or disks with selenium oxide, building them into a stack, and separating the disks with soft lead washers. Soft lead is used in preference

to other metals because it makes better contact on the selenium oxide since it can be pressed into the exact shape of the disks. Alternating current is applied to the stack, and taps are provided for outlet of the direct current. A selenium stack rectifying element is illustrated in figure 199.

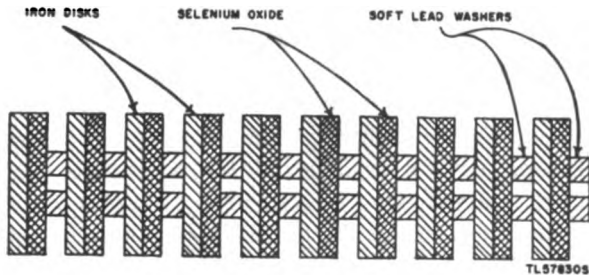

Figure 199. Construction of a selenium stack rectifying element.

130. Theory of Operation

a. HALF-WAVE RECTIFIER. A simplified half-wave rectifier is shown in figure 200. Alternating current is applied to the circuit and because the iron and selenium-oxide disk is connected in the circuit, current, to all effects, will flow through the meter in one direction only. That is, when the input current is in one direction, current will flow through the meter and resistor; but when the input current is in the opposite direction, there will be no current flow through the meter and resistor because of the characteristics of the rectifying disk. From this fact the name *half-wave rectifier* is derived. The applied, actual, and effective waveshapes are shown in figure 201. Some current is passed in the reverse direction (actual waveshape). The amount is negligible, however, and can be disregarded when the output of a half-wave rectifier is considered and only the effective waveshape taken into account. Half-wave rectifiers are not used with teletypewriter equipment but are sometimes used with telephone equipment for battery charging, etc. These, however, are normally vacuum tube rectifiers,

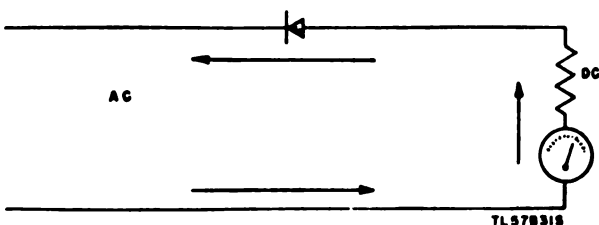

Figure 200. Simplified half-wave rectifier.



Figure 201. Waveshapes of half-wave rectifier.

because the low inverse voltage of the output of metallic-oxide rectifiers causes the break-downs.

b. FULL-WAVE RECTIFIER. A half-wave rectifier can be converted into a full-wave rectifier by connecting the selenium stack in a bridge-type circuit as shown in figure 202. In a full-wave rectifier, both halves of the a-c cycle that is applied to the selenium stack are rectified. On one half of the cycle, the current flow in figure 202 (solid arrows) is from terminal A to terminal E and No. 4 selenium disk, through terminal C, the meter, and resistor to terminal D, through selenium disk No. 2 and terminal F to terminal B, where the circuit is completed. The current cannot flow from terminals D to E or from F to C on this half cycle because the two terminals in each case are of equal potential. On the other half cycle (broken arrows), current flow is from terminal B to terminal F and selenium disk No. 1, to terminal C, through the meter and resistor to terminal D, through selenium disk No. 3 to terminal E, and then to terminal A, where the circuit is completed. In this case, there will be no current flow from terminals D to F and from E to C because there is no difference in potential between the respective terminals. Characteristics of the selenium disks keep the current from flowing in both directions, and both halves of the a-c cycle are caused to flow through the meter in the same direction and thus become direct current. The meter and resistor represent the d-c load. The input and the produced or output waveshapes are illustrated in figure 203. It should be noted that, although all current flow in the output waveshape is in the same direction (above zero line), it is not continuous but has a definite ripple.

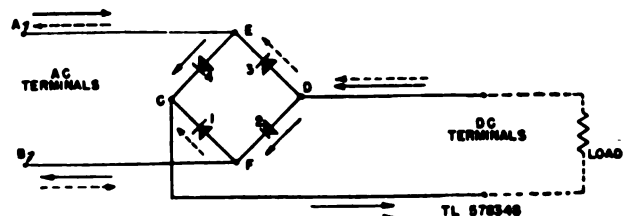

Figure 202. Simplified full-wave rectifier.



Figure 203. Waveshapes of simplified full-wave rectifier.

131. Circuit Components of Selenium Rectifiers

Although direct current may be obtained from a simple rectifying stack, it is not entirely satisfactory

for use with teletypewriter and other communications equipment. In order for the rectifying stack to be satisfactory, other circuit components are necessary to remove the ripple that is present in the output, to obtain and maintain the correct output voltage, and to keep the output voltage from fluctuating to a great extent with heavy and light loads.

a. FILTER CHOKE COIL. A filter is connected in the output circuit of a rectifier to eliminate ripple. One part of the filter is a choke coil placed in series with the output circuit (fig. 204) to help prevent abrupt changes in the magnitude of the current drawn by the rectifier load. The waveshapes formed by broken lines in figure 205 illustrate the current that is supplied by a full-wave rectifier without a choke coil. The heavy lines indicate the current when a series-connected choke coil is added to the output circuit. When current is applied to the circuit (beginning of waveshape), the counter-electromotive force opposes the current flow, causes it to build up in a more sloping form, and thus prevents it from reaching peak amplitude. When the current collapses (end of waveshape), the induced current is in a direction to aid the original current flow, causing the waveshape to be more sloped at that end. Because of the relatively high frequency, the current will not be reduced to zero as it is without the induction coil before the next half-cycle has begun and the current is again building up in the circuit. The choke coil used in most teletypewriter field set rectifiers is of the swinging type. That is, inductance decreases from no-load to full-load. This type of choke coil maintains a more constant output voltage with variation in rectifier output load.

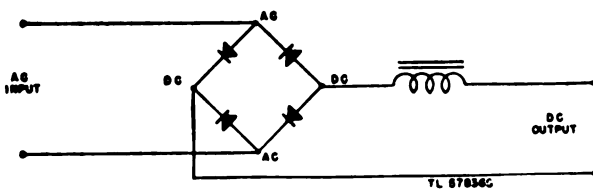

Figure 204. Simplified rectifier circuit with choke coil connected.

b. FILTER CAPACITOR. Though much better than the original waveshape, the output waveshape of a rectifier circuit such as shown in figure 205 is still not continuous but has a small pulsating effect. These pulsations can be reduced considerably by the connection of capacitors across the output circuit as shown in figure 206. The capacitors will be charged when the current is at peak amplitude and will dis-

charge into the output circuit when the current is at the lower part of its waveshape. The result of the addition of capacitors to the output circuit is almost pure direct current with very small pulsations. Figure 207 illustrates the output waveshape of a full-wave rectifier without choke coil or capacitors (broken lines) and the output waveshape of the same rectifier with both a choke coil and capacitors connected to form a filter (solid lines). Note that the peak voltage is lower than the original; it is therefore necessary to use a transformer to keep the output of the rectifier at the level desired. Two 500-microfarad (mf) capacitors are used in the filter of rectifiers used with teletypewriter field sets. The values of the capacitors in rectifiers with other teletypewriter equipment may differ, but the principle of operation remains the same.



Figure 205. Output waveshapes of simplified rectifier circuit with choke coil connected.

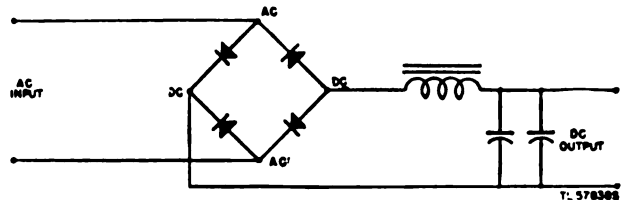

Figure 206. Simplified rectifier circuit with capacitors connected.

c. TRANSFORMER. Internal resistance within the simplified rectifier causes the output voltage to be less than the input. That is, if 115 volts were applied to the simplified rectifier circuit of figure 206, less than 115 volts would be in the output circuit. To counteract this loss in voltage a transformer is connected into the input circuit. (See figure 208.) The transformer has a greater number of turns in its secondary winding than in its primary, making it possible to apply a greater voltage to the rectifier stacks. Thus it is possible to obtain the same voltage in the output circuit as is in the input circuit. The voltage values given in figure 208 are hypothetical and in actual practice are dependent upon the amount of output voltage desired. This method of obtaining the correct output is sufficient as long as the input voltage is correct. However, greater control can be obtained by connecting a transformer provided with taps in either or both the primary and secondary windings. A rectifier

circuit with a variable type transformer connected is illustrated in figure 209. The voltage to the rectifier stack can be kept at the right value on an input of 90 to 250 volts. For example, if the source of alternating current is 95 volts, the a-c lead is connected at the 95-volt tap (the other lead is not changed). With the leads so connected, the transformer becomes a step-up transformer, providing the rectifier stack with sufficient voltage to cause the d-c output voltage to be the amount desired. (Normally, with teletypewriter equipment, the correct voltage is 115.) When the input voltage is higher than the desired output, the input lead is connected to the corresponding tap and the transformer becomes a step-down and the proper amount of voltage is applied to the rectifying stack. In some cases, such as with rectifier REC-12, all necessary changing of the transformer ratio is done at taps in the secondary winding. This method, however, is used, not to permit the rectifier to be used over a wider range of input voltages, but to obtain desired voltages of direct current on definite voltages of alternating current. Most teletypewriter rectifiers that use this method are designed for operation on 105 to 120 volts of alternating current only and have two sets of taps, both on the secondary winding. One set of taps is to obtain an approximately correct d-c output and is called *coarse* taps. The other set, *fine*, varies the amount of d-c voltage in smaller steps, permitting a more exact setting. One selenium rectifier (Rectifier RA-37) used with teletypewriter field sets has two sets of transformer taps located in the primary winding. These taps are graduated in 10- and 5-volts steps, permitting the rectifier output to be kept at 115 volts on an input of 90 to 125 volts. The other field rectifier (Rectifier RA-87) is similar to Rectifier RA-37 except that taps are provided in both the primary and secondary windings. The taps in the secondary provide for setting the output voltage nearer the exact amount desired after it has been approximated by the setting of the taps in the primary winding. The secondary taps vary the amount of output voltage in three 5-volt steps, and the taps in the primary provide an input range of 90 to 250 volts. The transformer in Rectifier RA-87 provides 115 volts alternating current for operation of the teletypewriter motor by forming an auto-transformer at the primary winding. A second tap at the 115-volt primary tap forms a secondary winding within the primary (fig. 210) and, in cases where the rectifier input is higher than 115 volts, the primary winding in itself becomes a step-down transformer. If the input voltage is lower than 115 volts, the primary winding forms a step-up transformer. Thus correct voltage is supplied the teletypewriter motor regardless of the rectifier input voltage.

fier RA-87) is similar to Rectifier RA-37 except that taps are provided in both the primary and secondary windings. The taps in the secondary provide for setting the output voltage nearer the exact amount desired after it has been approximated by the setting of the taps in the primary winding. The secondary taps vary the amount of output voltage in three 5-volt steps, and the taps in the primary provide an input range of 90 to 250 volts. The transformer in Rectifier RA-87 provides 115 volts alternating current for operation of the teletypewriter motor by forming an auto-transformer at the primary winding. A second tap at the 115-volt primary tap forms a secondary winding within the primary (fig. 210) and, in cases where the rectifier input is higher than 115 volts, the primary winding in itself becomes a step-down transformer. If the input voltage is lower than 115 volts, the primary winding forms a step-up transformer. Thus correct voltage is supplied the teletypewriter motor regardless of the rectifier input voltage.



Figure 207. Output waveshapes of simplified rectifier circuit with choke coil and capacitors connected.

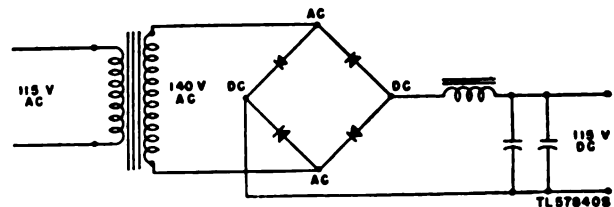

Figure 208. Rectifier circuit with transformer connected.

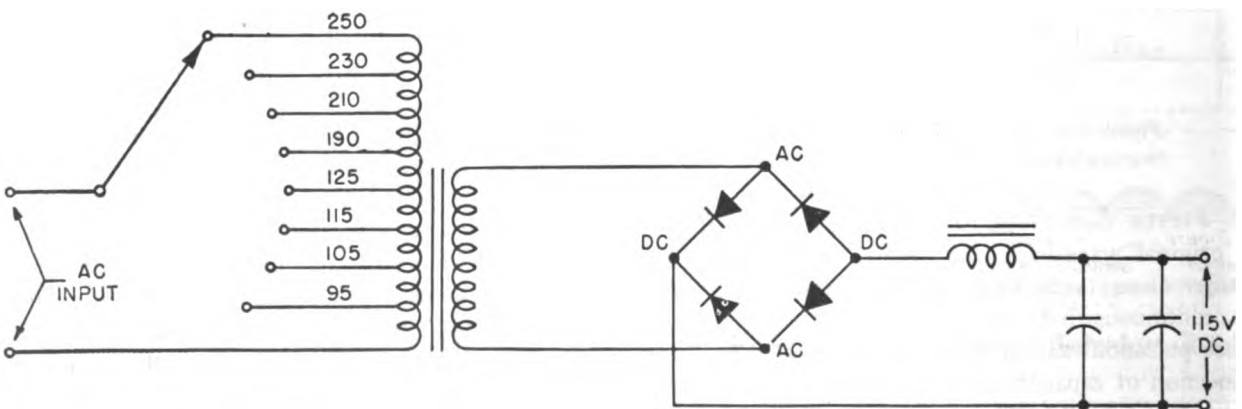

Figure 209. Rectifier circuit with variable transformer connected.

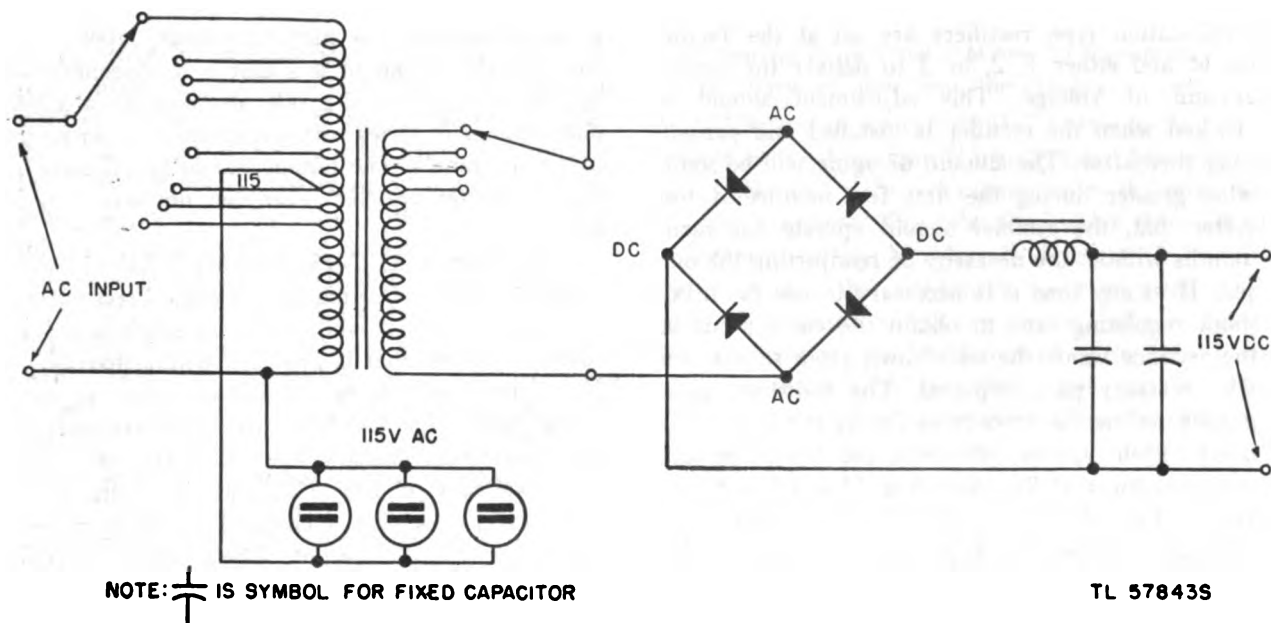

Figure 210. Rectifier circuit with primary winding forming an auto-transformer.

d. **BLEEDER RESISTOR.** In the rectifier circuits thus far covered, no provision was made for reducing the change in voltage of the rectifier from no-load to full-load and vice versa. This change is, of course, very undesirable in teletypewriter equipment inasmuch as the load on the rectifier may be changed from no-load to full-load several times a second. By connecting a bleeder resistor across the output circuit of the rectifier, a constant load is maintained, thus preventing the d-c voltage from rising too much when small loads are used. That is, a constant load is provided for the rectifier output which keeps the percentage of increase or decrease in load at a smaller value. Figure 211 is a schematic diagram of a rectifier circuit with the bleeder resistor connected.

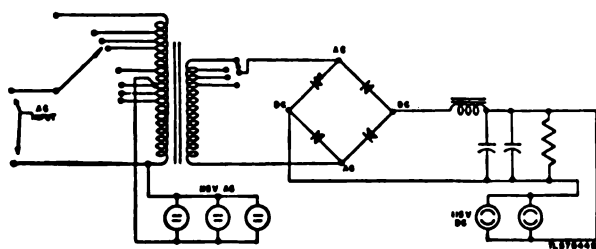

Figure 211. Schematic diagram of rectifier circuit with bleeder resistor connected.

e. **POWER FACTOR CAPACITOR.** Some rectifiers used with fixed-station teletypewriter equipment are equipped with a power factor capacitor. This capacitor is connected across the input circuit and tends to neutralize the inductive reactance of the

primary winding, thereby aiding in the output of the rectifier. Part of the primary winding is connected in series with the capacitor, forming a filter to eliminate distortion in the a-c waveshape caused by other frequencies. This also aids the rectifier output by causing an undistorted waveshape to be applied to the rectifying element.

f. **VOLTAGE REGULATOR.** A few rectifiers used with fixed-station equipment use a voltage regulator (with taps) in the output circuit to obtain the correct amount of direct current. The regulator is not a transformer but works on a somewhat similar principle. Each of the five fine adjusting taps change the output approximately 2 volts, and each of the three coarse taps change it approximately 8 volts. This type rectifier also has taps in the primary winding for connections of 105, 115, and 125 volts of alternating current. The latter taps must not be used for obtaining the desired amount of output. They are incorporated solely for connection to the proper input power.

132. Testing Procedures

Aging, which is an increase of as much as 25 percent in internal resistance of the rectifying element, occurs in some rectifiers during the first few months of use and must be compensated for by changing the taps of the transformer or regulator. This aging effect is accentuated by operation at high temperatures. Therefore, the rectifiers must never be operated above the rated output. The taps of

fixed-station type rectifiers are set at the factory on M and either 1, 2, or 3 to deliver the correct amount of voltage. This adjustment should be checked when the rectifier is installed and periodically thereafter. The amount of aging will be somewhat greater during the first few months of use. After that, the rectifier should operate for many months without the necessity of readjusting the output. If at any time it is necessary to use the maximum regulating taps to obtain the correct output, the rectifier should be withdrawn from service and the necessary parts replaced. The following paragraphs outline the procedures for testing the various fixed-station type metallic-oxide rectifiers. For testing procedures of Rectifiers RA-37 and RA-87, refer to TM 11-955 and TM 11-957, respectively. Schematic and wiring diagrams of the most widely used selenium rectifiers are given at the end of this section.

a. **RECTIFIER REC-10.** Rectifier REC-10 is designed to deliver 200 ma at 120 volts of direct current from a 105- to 125-volt, 50-60-cycle, single-phase a-c source. The direct current from this unit is suitable for supplying power to the signaling circuits of teletypewriter equipment. The method normally used for checking the d-c output of this rectifier is to disconnect all apparatus from the d-c side and connect a 600-ohm resistor in series with a milliammeter across the output terminals. For correct adjustment of the output, the flexible leads should be connected to those taps that will cause the milliammeter to register a current flow that is nearest to but not less than 200 ma.

b. **RECTIFIER REC-11.** Rectifier REC-11 is designed to deliver 600 ma at 120 volts of direct current from a 105- to 125-volt, 50-60-cycle, single-phase a-c source. The direct current from this rectifier is not suitable for supplying power to the line or any other signaling circuits of teletypewriter equipment. It is normally used for supplying power to the punch magnets of the keyboard perforator. The method normally used in checking the d-c output is to disconnect all apparatus from the direct current and connect a 60-watt Mazda lamp in series with a suitable ammeter across the output terminals. For correct adjustment, the flexible leads should be connected to those taps that will cause the ammeter to register a current flow that is nearest to but not less than 500 ma.

c. **RECTIFIER REC-12.** Rectifier REC-12 is designed to deliver 125 ma at 120 volts direct current from a 105- to 125-volt, 50-60-cycle, single-

phase a-c source. The method normally applied for checking the output of this unit is to disconnect all apparatus from the d-c side and connect a 1,260-ohm resistor in series with a milliammeter across the output terminals. The output should be adjusted so that the meter registers near, but not less than 98 ma.

d. **RECTIFIER REC-13.** Rectifier REC-13 is designed to deliver 600 ma at 120 volts direct current from a 105- to 125-volt, 60-cycle, single-phase a-c source. This rectifier is provided with a door in the front of its cover to permit access to the two regulating panels. The left-hand panel has terminals for the transformer primary taps which are marked for input voltages of 105, 115, and 125 volts. In no case should these taps be changed for the purpose of regulating the d-c output. Their setting depends solely on the voltage of the a-c input. The method normally used for checking the output of this rectifier is to disconnect all apparatus from the d-c side and connect a 60-watt Mazda lamp in series with suitable ammeter across the output terminals. For correct adjustment, the flexible leads should be connected to the taps that will cause the ammeter to register a current flow that is nearest to, but not less than 500 ma.

e. **RECTIFIER REC-14.** Rectifier REC-14 is the same as rectifier REC-13 except that it is designed for operation on 25-cycle alternating current. The normal method of testing is the same as for rectifier REC-13.

f. **RECTIFIER REC-19.** Rectifier REC-19 is the same as rectifier REC-11 except that it is designed for operation on 25-cycle alternating current. The normal method of testing is the same as for rectifier REC-11.

g. **RECTIFIER REC-20.** Rectifier REC-20 is the same as rectifier REC-10 except that it is designed for operation on 25-cycle alternating current. The normal method of testing is the same as for rectifier REC-10.

h. **RECTIFIER REC-23.** Rectifier REC-23 is the same as rectifiers REC-13 and REC-14 except that it is designed for operation on 50-cycle alternating current. The normal method of testing is the same as for rectifier REC-13.

133. Trouble-shooting Procedures

The best means of keeping rectifiers in proper working order is to prevent troubles before they can occur. A great percentage of troubles that occur in rectifiers, especially of the selenium type, are

direct results of careless handling of the cords and plugs, maladjustment of the transformer taps, and incorrect capacity fuses. If care is taken to correct these faults and if the rectifiers are kept absolutely free from all foreign materials such as dust, corrosion, fungus, etc., they should operate satisfactorily for many months without repairs or adjustments after the initial aging period is completed. Good preventive maintenance practices and a well-ventilated location for the rectifiers will keep communication break-downs caused by rectifier trouble to an absolute minimum. The following paragraphs outline trouble-shooting procedures for the fixed-station type rectifiers. Refer to TM 11-955 and TM 11-957 for trouble-shooting procedures on rectifiers used with field teletypewriter sets. Wiring and schematic diagrams of rectifiers REC-10 and REC-13, and Rectifiers RA-37 and RA-87 appear at the end of this section.

a. **NO D-C OUTPUT VOLTAGE.** Several different factors, such as a burned-out transformer, loose and broken connections, blown fuse, shorts caused by defective capacitors, crossed wires, etc., may result in no d-c output voltage. Probably the best method of locating the trouble is to check the entire circuit with a voltmeter, starting at the input and working toward the output receptacles. The greater percentage of troubles, however, can be found simply by checking the plug connections and the fuses. A blown fuse should never be replaced with one of a capacity other than that indicated on the diagrams. Insertion of the wrong capacity fuse may result in the complete destruction of items of equipment, some of which are difficult to obtain.

b. **EXCESSIVE OUTPUT VOLTAGE.** Excessive output voltage can be caused by any one or more of the following: Shorted choke, open bleeder resistor, or maladjustment of the transformer or regulator taps. The bleeder resistor and adjustment of the transformer or regulator taps should be checked first, and, if the trouble is not found to be in one of these, the choke coil can be removed and another known to be in good condition substituted. The resistance of this coil is so low that its condition cannot be accurately checked without an inductance bridge. If the exact resistance of the coil is known, a Wheatstone bridge may be used to test for a short. The Wheatstone bridge method is not a check on the accuracy of the coil but only measures the resistance. The resistor can be checked by opening the circuit on each side (power disconnected)

and placing an ohmmeter across its terminals. If the meter gives no indication, the resistor is open.

c. **EXCESSIVE RIPPLE IN D-C OUTPUT.** Excessive ripple in the d-c output is usually caused by a defective choke coil, defective capacitors, or defective rectifying elements. The best method of determining whether these components are defective is by substituting ones that are known to be in good condition. A resistance check can be made of the rectifying elements which should show very high resistance in one direction and practically none in the other. The unit should be disconnected and the strap removed when the test is made. A resistance check of the rectifying elements should not be considered an accurate check on its efficiency. The capacitors may be checked by placing a voltmeter across their terminals (power connected). If no reading is obtained, the capacitor is shorted. The capacitor can also be tested with an ohmmeter with no power connected, but this cannot be considered a definite check on its efficiency inasmuch as the meter applies less than 3 volts while the normal operating voltage of the capacitor is 115 volts. For an accurate check on both the inductance coil and the capacitors, an impedance bridge is necessary.

d. **TRANSFORMER TEST.** The transformer can be given a resistance test but because the resistance is extremely low, a Wheatstone bridge is necessary. The resistance of each complete winding of a transformer of the type used in rectifiers is usually about 2 ohms. This test is necessary only when trouble is traced to the transformer. Here, again, the best method of determining the efficiency is to substitute another like component that is known to be in good condition.

134. Vacuum Tube Rectifiers

Rectification of alternating current with vacuum tubes is based on the same characteristic as with selenium rectifiers, that is, the ability to pass electrical current in but one direction. Tube-type rectifiers are used with teletypewriter equipment where the load is greater than normal. Because the output must be relatively high, gas-filled tubes are very commonly used. The addition of gas (argon and/or mercury vapor) into a vacuum tube greatly increases the conductivity, thereby increasing the output of the tube. Circuits of vacuum tube rectifiers are somewhat similar to those of selenium rectifiers but, because of tube characteristics and greater output, more circuit components are necessary.

135. Theory of Vacuum Tube Rectifier Operation

a. HALF-WAVE RECTIFIER. The simplest form of vacuum tube, which in itself is a rectifying element, is the diode, consisting of a cathode and plate. (See A of fig. 212.) If battery is connected to the tube in such a manner as to cause the plate to be at a positive potential with respect to the cathode (B of fig. 212), current will flow within the tube across the cathode and plate when the cathode is heated. A reversal of battery connections will place the plate at a negative potential with respect to the cathode and no current will flow within the tube or external circuit to which the plate and cathode are connected. This characteristic of the vacuum tube makes it a rectifying element inasmuch as it will allow current to flow in one direction only. One other circuit is necessary, however, before the tube can be made to pass electrical current. The filament, usually located within the cathode, is used as a heating element for the cathode which must be heated before the tube can function. This filament is heated by connections to an external circuit (A of fig. 213), and because it is located near the cathode, the cathode becomes heated and the tube is allowed to function. The tube, however, is still a diode because only two elements, plate and cathode, are active so far as the function of the tube is concerned. In many rectifying tubes, the heating element and cathode are combined as illustrated in B of figure 213. If an alternator or other source of alternating current is connected in place of the battery, a half-wave rectifier will be formed (See fig. 214.) On one half-cycle of applied alternating current the plate of the tube will be positive and the cathode negative. This permits current to flow through the tube, completing the circuit through the meter and resistor. On the other half-cycle, however, the applied current is reversed, making the plate of the tube negative and the cathode positive and, because of vacuum tube characteristics, current cannot flow in the circuit. Consequently, the meter at the d-c load will

register no current flow on that half-cycle. The alternating applied waveshape and the produced pulsating d-c waveshape are also shown in figure 214. The battery connected to the vacuum tube is used solely for heating the filament and has no effect on the output of the rectifier except to keep the vacuum tube functioning.

b. FULL-WAVE RECTIFIER. The half-wave rectifier may be changed into one which utilizes both halves of the a-c cycle by the addition of a center-tapped transformer and another vacuum tube. (See fig. 215.) The plates of the two tubes are connected to the secondary winding of the transformer in such a manner that one plate is charged positive and the other negative on each half-cycle of induced a-c voltage. When the induced current is in a direction to cause the plate of the top tube to be at a positive potential, a circuit will be set up as shown in A of figure 216. The circuit shown in B of figure 216 is set up on the other half-cycle. Regardless of the direction of induced voltage, the current flow through the output circuit is in the same direction, thus becoming direct current.

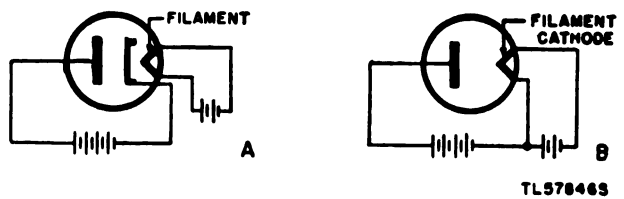

Figure 213. Operation of diode vacuum tube.

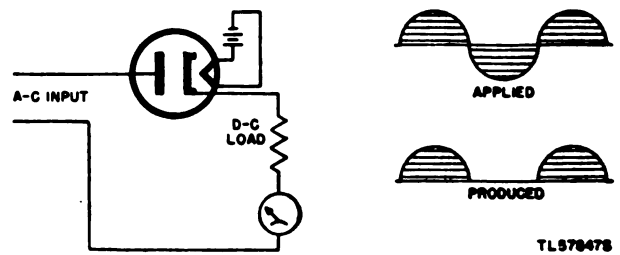

Figure 214. Half-wave vacuum tube rectifier with applied and produced waveshapes.

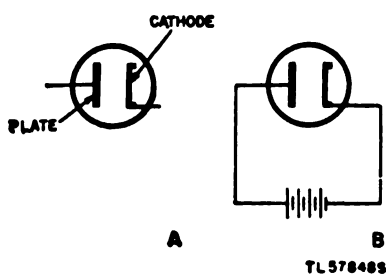

Figure 212. Diode vacuum tube.

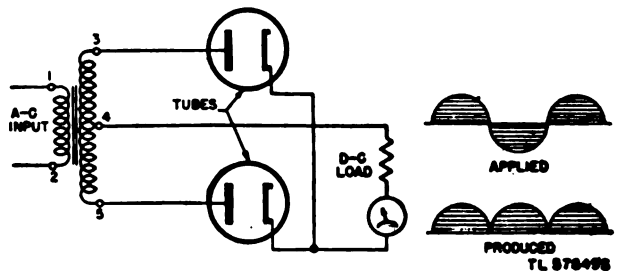

Figure 215. Full-wave vacuum tube rectifier with applied and produced waveshapes.

136. Circuit Components of Vacuum Tube Rectifiers

Other components are necessary with full-wave vacuum tube rectifiers to permit their use with teletypewriter equipment. For the most part, they serve the same purposes as the components used in selenium rectifiers. That is, they are used to step up or step down the input voltage and make it possible to operate the rectifier on variations of input voltage; to remove the ripple that is present in the output; to obtain and maintain the correct output voltage, and to prevent the output voltage from fluctuating to a great extent with variations in d-c load. In addition, a method is provided to prevent the application of the d-c load or plate current before the cathodes have become sufficiently heated. This latter function is necessary to prolong the life of the rectifier tubes. The following subparagraphs apply to all teletypewriter vacuum tube rectifiers used at the present time and no trouble should be encountered in the analysis of individual rectifier circuits if a good knowledge of the inserted diagrams is obtained.

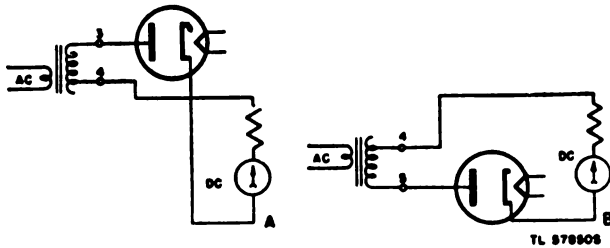

Figure 216. Effective circuits for a complete a-c cycle.

a. TRANSFORMERS. As outlined in paragraph 135b, a transformer is necessary to provide a center tap or common path of the output circuit of each tube. This transformer supplies correct voltage for the plates of the rectifying tubes and is called the plate transformer. Because the plate voltage is normally greater than the input voltage, each half of the plate transformer secondary winding will usually be operated as a step-up transformer. Normally, the primary is equipped with taps which are similar to those in selenium rectifiers. They provide for connections to 80-100, 100-125, 200-250 volts of alternating current. The taps may be changed from 80-100 to 100-125 in Rectifier RA-43-(*) by a switch. (See fig. 217.) This switch is not connected when the tap is set at 200-250. Power for a teletypewriter motor is tapped off the primary winding. Thus, correct power will be supplied the motor regardless of the input power. Power for an auxiliary transformer is

also tapped off at the 115-volt connection of the primary winding. The auxiliary transformer is used for supplying a-c voltage to the filaments of the rectifying tubes and to the control circuits. The secondary winding of the auxiliary transformer shown in figure 217 supplies alternating current of low voltage to the rectifier tubes for heating the filaments and is center-tapped to provide one side of the output circuit. Other secondary windings of this transformer are covered in later subparagraphs in conjunction with their respective circuits. A third transformer is incorporated in one of the rectifier control circuits and is covered in the following subparagraph.

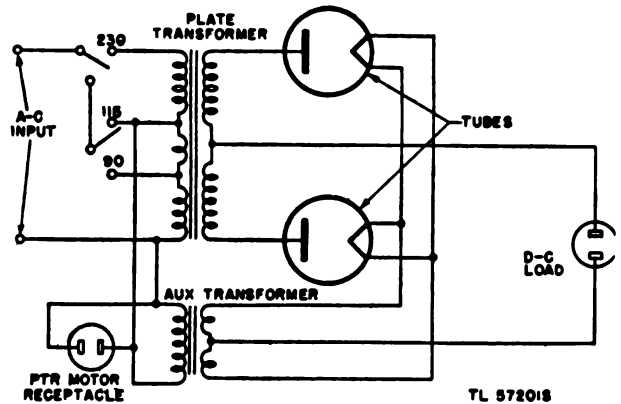

Figure 217. Full-wave vacuum tube rectifier with auxiliary transformer.

b. MICROSWITCH AND ASSOCIATED CIRCUITS. A system to allow the rectifying tubes to warm up sufficiently before the d-c load or plate current is applied is incorporated in vacuum tube rectifiers used with teletypewriter equipment. The system includes a time-delay (micro) switch, heater transformer, and output relay. The windings of the output relay are connected across the output circuit by contacts at the microswitch and its armature and contacts are in series with the output circuit. The operation of a simplified circuit of this type is shown in A of figure 218. When alternating current is supplied to the plate transformer, it is also connected to the primary winding of the heater transformer. The secondary of that transformer is connected to two bimetal strips that slowly bend because of the heat generated by current flowing through them. This current flow must be large for proper operation of the metal strips; therefore, the heating element is a step-down transformer. The slow-bending movement of the bimetal strips allows enough time for the tubes to warm up and then closes the contacts

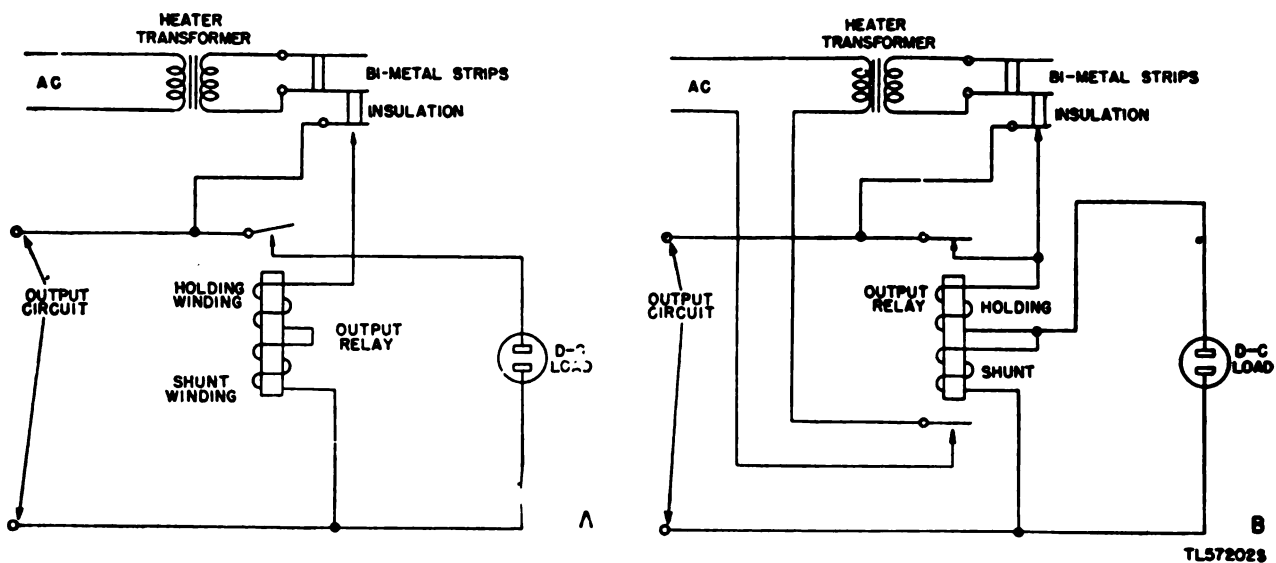

Figure 218. Operation of microswitch and associated circuits.

of the microswitch. The closing of these contacts causes a current flow through the output relay windings and this causes its armature to close, completing the output circuit. If the circuit were to be left as shown in A of figure 218, the bimetal strips of the microswitch would continue to bend after the output circuit was closed, as the high current value would be constantly applied by the heater transformer. Since this movement is undesirable, as soon as the contacts of the output relay are closed the circuit is connected as shown in B of figure 218. As soon as the armature of the output relay closes, a circuit through the holding winding, and d-c load (if applied) is connected. If no d-c load is connected, the circuit will be formed by the shunt winding of the relay which is connected to the other side of the output circuit. Thus, the relay will be kept closed by its own contacts. The microswitch is caused to assume its original position by the connection of another pair of contacts at the output relay into the primary circuit of the heater transformer. When the relay closes the contacts in the output circuit, it opens the contacts at a second armature which opens the circuit to the primary winding of the heater transformer. Thus, current will no longer flow through the bimetal strips and they will go back to their natural position, opening the contacts at the microswitch. The output relay will remain in its operated position, however, until the alternating current to the plate transformer is disconnected. Figure 219 is an illustration of a full-wave vacuum tube rectifier with this time-delay circuit connected. Some tube type rectifiers use somewhat different opera-

tions of the microswitch and associated circuits. The sequence of operation, however, is essentially the same. In such cases (fig. 220), a single-winding output relay is connected across the output circuit and is shorted out by the microswitch. When current is applied to the bimetal strips, their bending operation opens the contacts at the switch. This removes the short and the current flow is through the winding of the output relay. The relay in turn closes the output circuit, permitting the load to be applied, and opens the primary circuit of the heater transformer so the microswitch reverts to its closed position. As long as the relay remains closed, it holds the circuit to the microswitch contacts open, so that when the microswitch contacts are closed they will not short out the relay winding. This type of circuit operation does not prevent the application of plate current but it does limit the amount by keeping the d-c load from being applied before the tubes have warmed up. However, it has one great disadvantage: When the d-c load is heavy, insufficient current flows through the winding of the output relay so that it releases and opens the output circuit. Because the output circuit is disconnected, sufficient current will flow through the winding, operating the armature. This again closes the output circuit. This fluttering effect at the relay armature produces excessive arcing which results in badly burned contacts.

c. **VOLTMETER.** The voltmeter used in Rectifiers RA-43-(*) is connected and controlled by a double-pole, double-throw switch. (See figs. 219 and 220.) When the switch is in its d-c position, the meter is connected across the output circuit and indicates

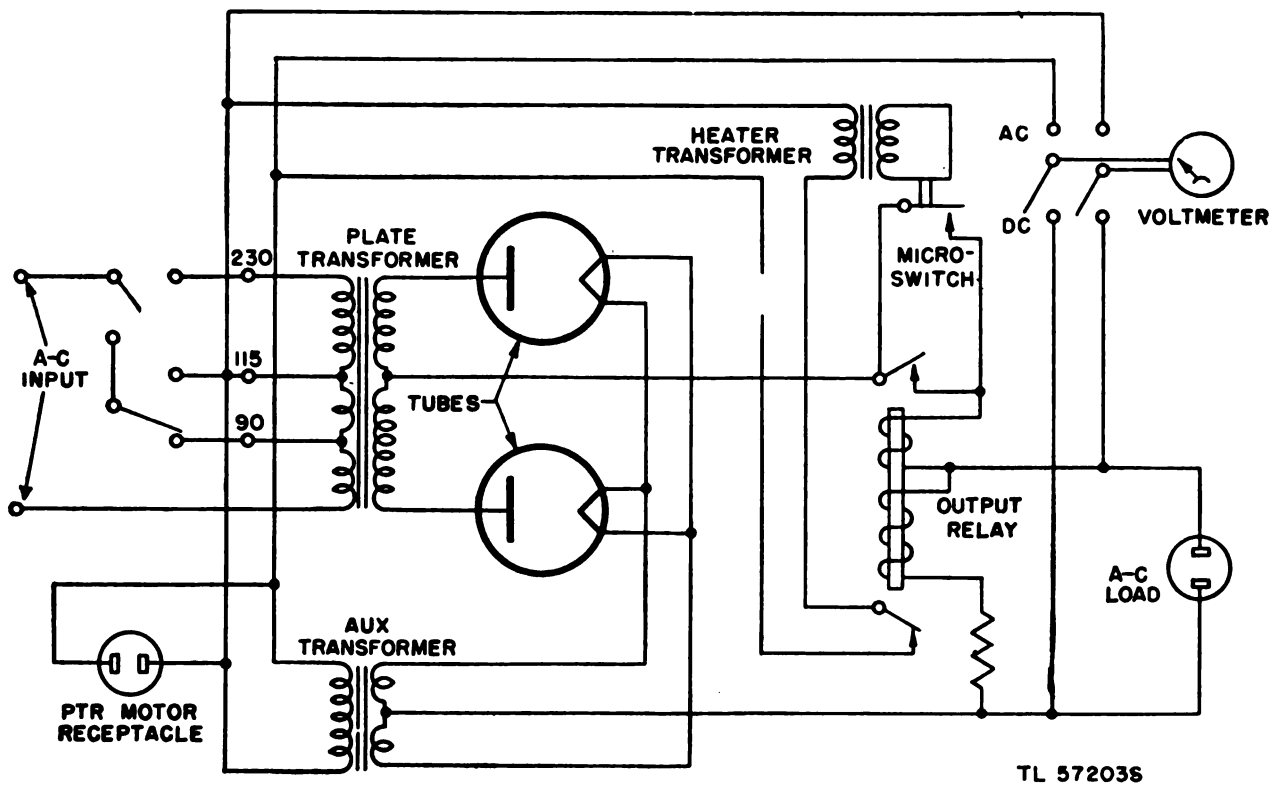

Figure 219. Full-wave rectifier with time delay and meter circuits.

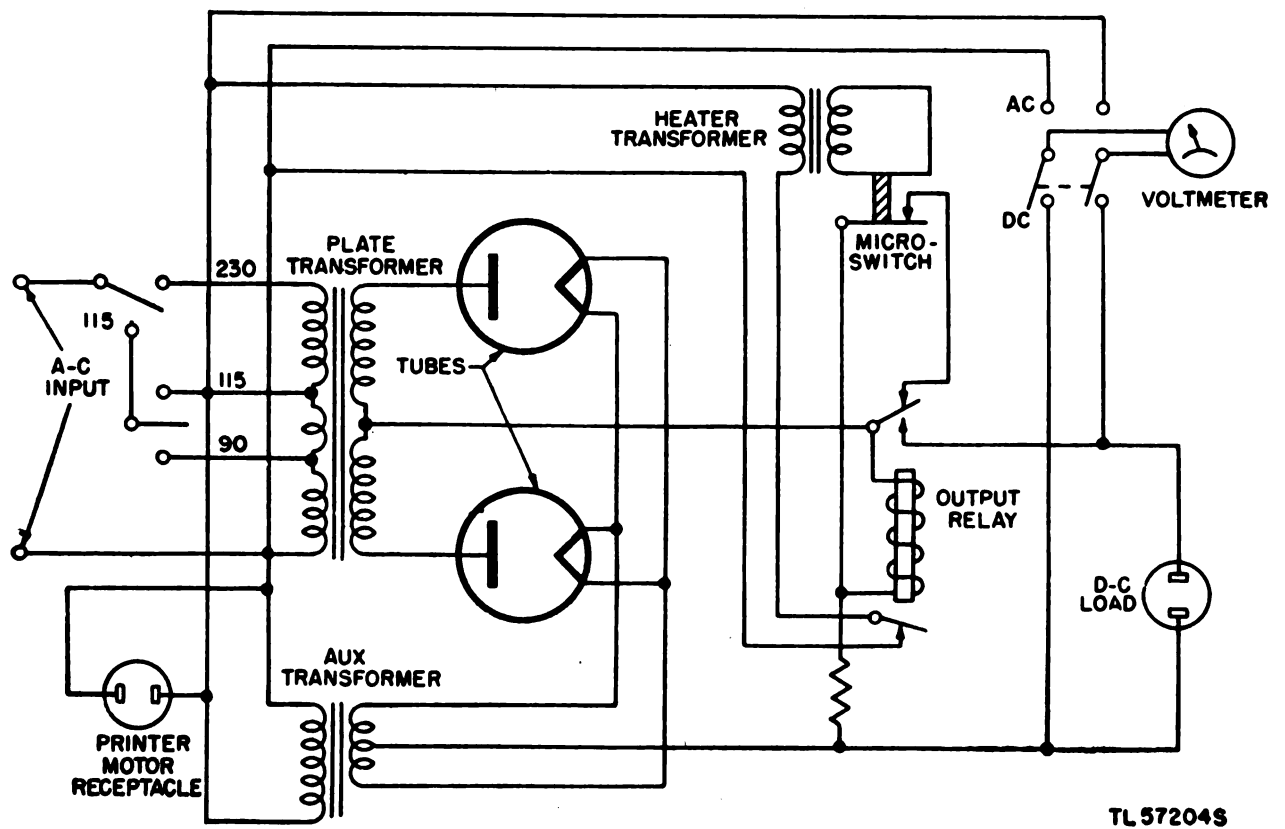

Figure 220. Full-wave rectifier with short-circuit type time-delay circuit.

the output voltage. With the switch in the a-c position, the meter is connected across the input circuit at the 115-volt tap of the plate transformer. Thus, the meter does not indicate the voltage to which the rectifier is connected but should indicate approximately 115 volts regardless of the amount of input. However, if the input is incorrectly connected, the meter will show more or less the normal 115.

d. THYRATRON TUBES. The rectifier vacuum tubes covered so far are diodes. In tube-type rectifiers such as are used with teletypewriter equipment, it is necessary to use gas-filled (thyatron) tubes as they pass a greater amount of current. It is also necessary that some means of controlling and maintaining the output of the vacuum tubes be incorporated. To accomplish this, a third element is added to the tube between filament (or cathode) and plate. This element, which is called a control grid, has in itself no means of correcting the output of the tube but it does exert control by the amount of potential placed upon it by an outside circuit. Figure 221 illustrates a thyatron tube with negative battery connected to the grid, with no battery connected to the grid, and with positive battery connected to the

grid. The A battery is for heating the filament, the B battery supplies plate voltage, and the C battery applies the grid potential. The meter readings show that greater output voltage is obtained as the grid potential rises or becomes more positive. Thus, the output can be controlled by a variation of grid potential. The initial voltage that is applied to the grids of the rectifier tubes is obtained from another secondary winding of the auxiliary transformer. (See fig. 222.) Connections are made so that the same potential is applied to both grids regardless of the direction of current flow in the secondary winding.

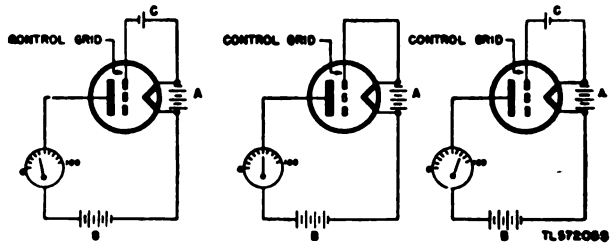

Figure 221. Operation of control grid in thyatron vacuum tube.

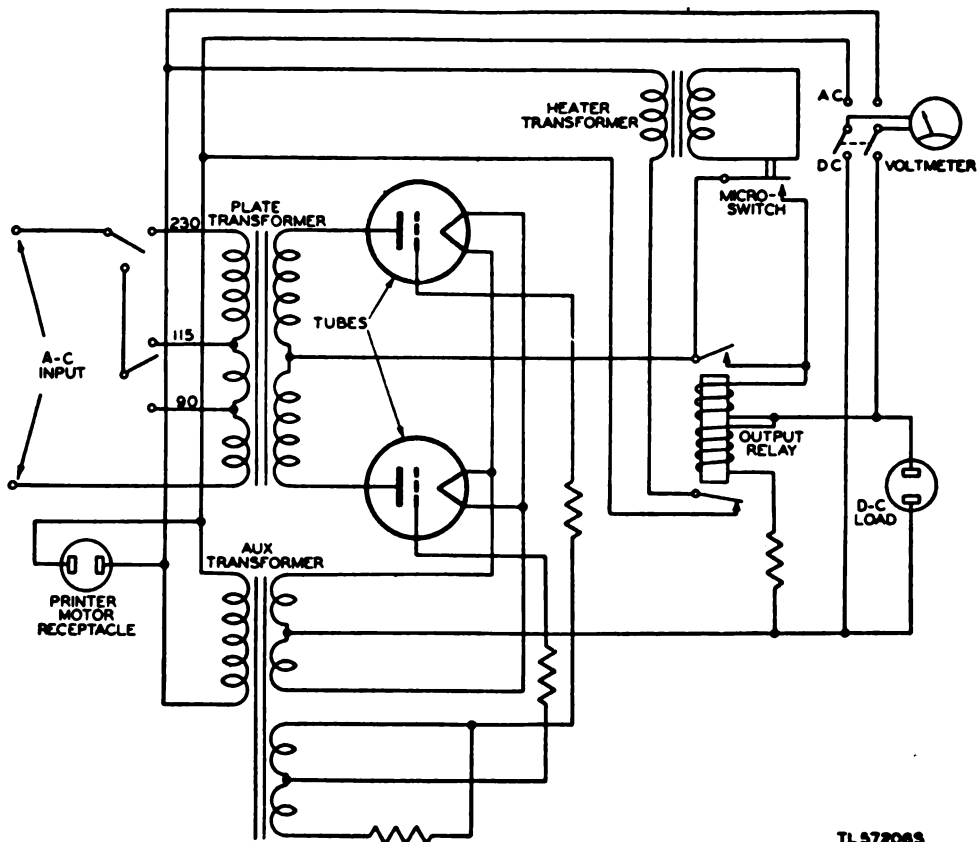

Figure 222. Full-wave thyatron tube rectifier.

TL 572085

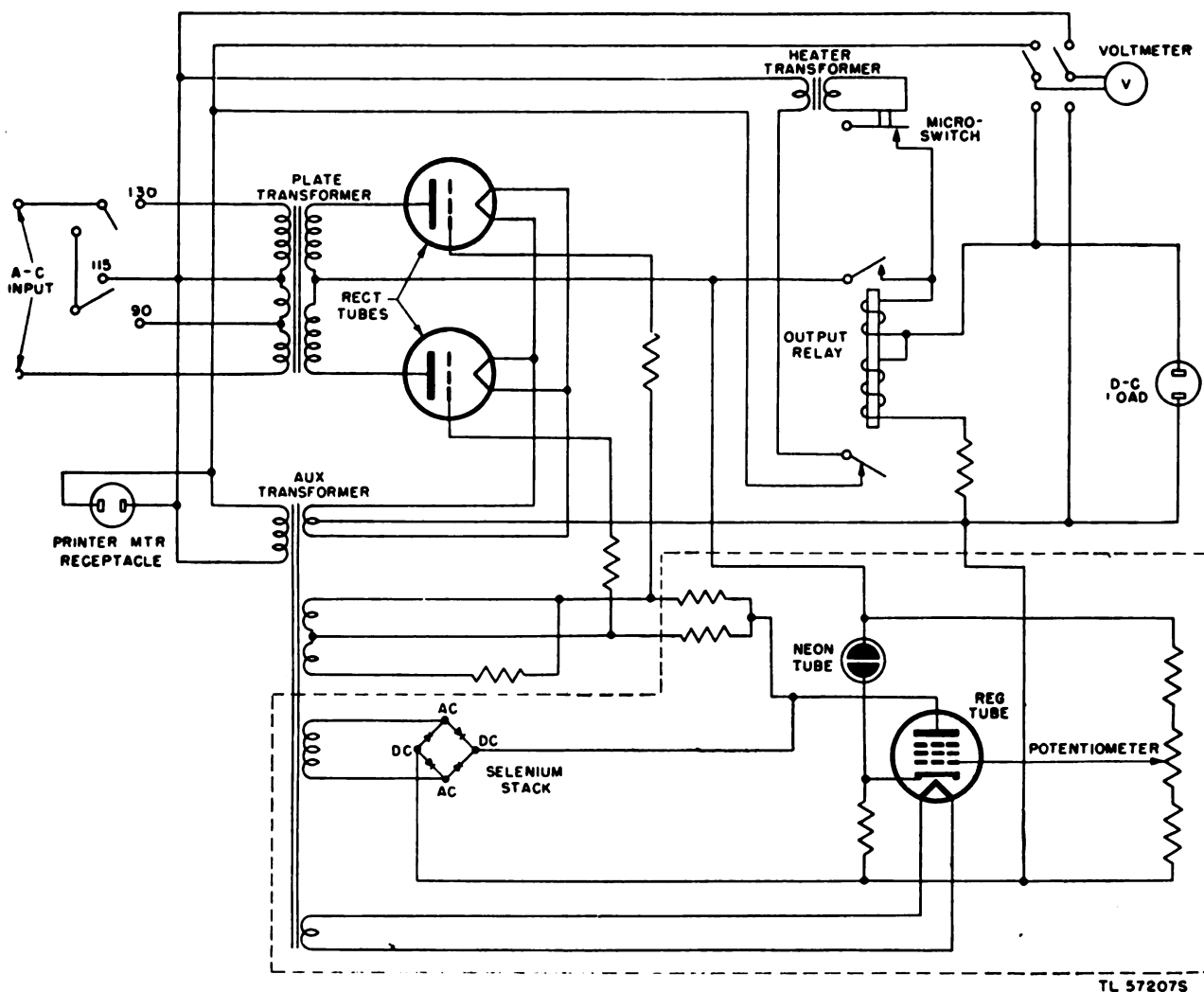

Figure 223. Full-wave vacuum tube rectifier with electronic voltage regulator.

e. ELECTRONIC VOLTAGE REGULATOR. An electronic voltage regulator is incorporated in teletype-writer vacuum tube rectifiers to prevent an increase and decrease in output voltage caused by load fluctuations. This regulation is not necessary with selenium-type rectifiers because the output is small and they are normally used with but one machine or line unit. Figure 223 is a schematic diagram of a vacuum tube rectifier with the electronic voltage regulator included. This regulator circuit (inclosed in broken lines) utilizes a vacuum tube that has its plate circuit connected to the grids of the rectifier tubes. Consequently, any change in the output of the regulator tube will affect the potential applied to the grids of the rectifier tubes which will cause an increase or decrease in the output voltage of the rectifier. The circuit is designed so that any decrease in

output voltage of the rectifier (application of a heavier load) results in a greater output of the regulator tube, making the grids of the rectifier tubes more positive and resulting in an increase in rectifier output voltage. If the load is decreased, the rectifier output voltage is increased and the regulator tube is caused to supply a less positive potential to the grids of the rectifying tubes. This causes the output voltage to decrease to the correct amount. D-c voltage for the regulator tube is obtained from a selenium stack that is connected to a third secondary winding of the auxiliary transformer. The fourth secondary winding supplies alternating current for heating the filament. The rectifier output voltage may be set to the amount desired (usually 115 volts) by the potentiometer connected to the control grid of the regulator tube. Any change in this grid's

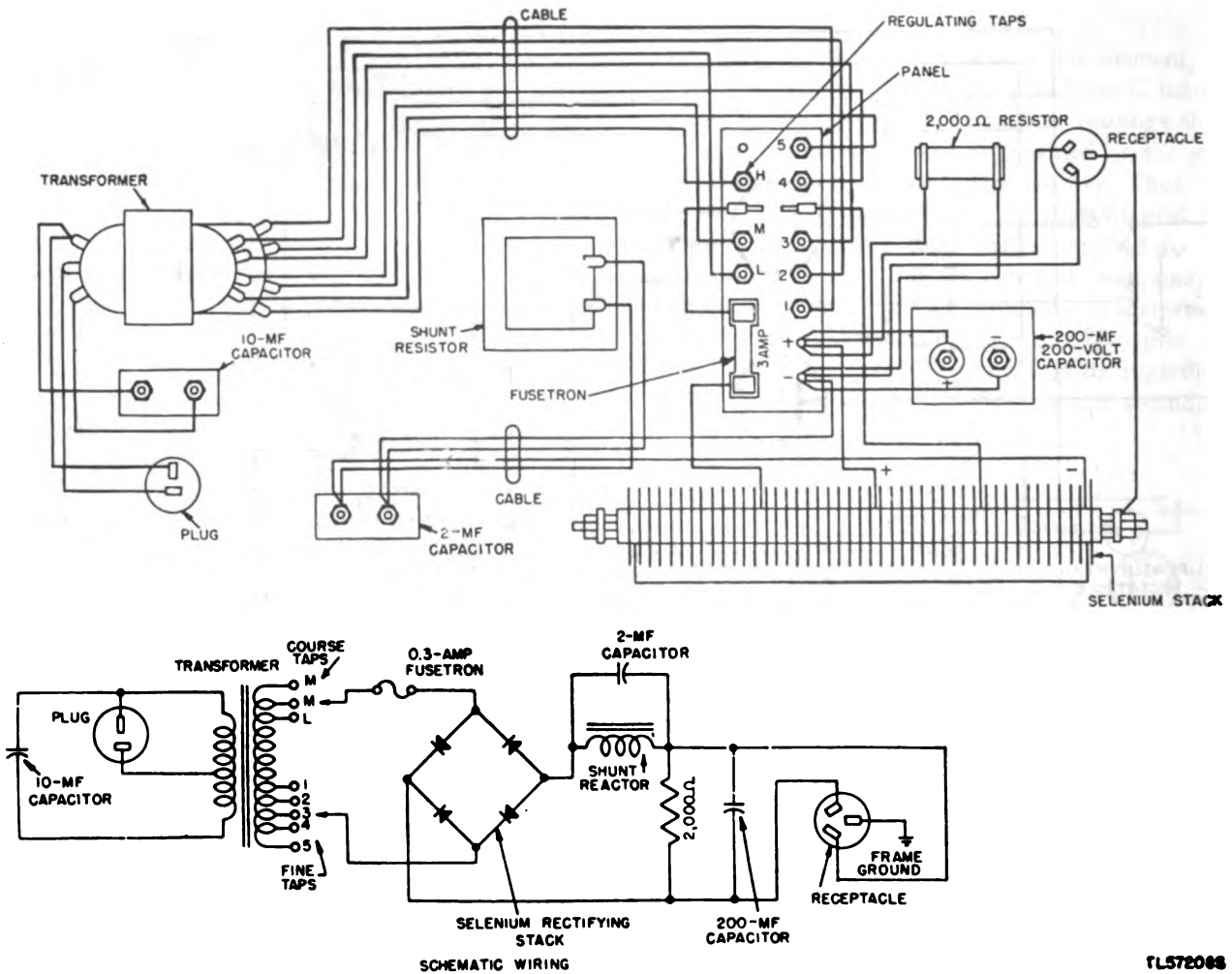

Figure 224. Wiring and schematic diagrams of rectifier REC-10.

TL572068

potential will change the output of the regulator tube, thereby changing the output of the rectifier by increasing or decreasing the grid potential of the rectifying tubes. The other grids of the regulator tube are not directly concerned in circuit operation but are necessary for efficient operation of the tube. The neon bulb is necessary to reduce the potential of the cathode of the regulator tube.

f. OTHER COMPONENTS. Most choke coils and capacitors connected in the circuits of vacuum tube rectifiers are used similarly to those in selenium rectifiers (prevention of ripple in the d-c output). Other coils and capacitors are connected as filters to prevent noises in nearby radio equipment.

137. Inspection, Service and Repair, and Trouble Shooting

The principle vacuum tube rectifiers used with teletypewriter equipment are Rectifiers RA-43-A

and RA-43-B, schematic diagrams of which are illustrated in figures 228 and 229, respectively. The procedures for inspection, service and repair, and trouble shooting of these units are in TM 11-954. These procedures primarily are for Rectifier RA-43-B but may be applied to the RA-43-A as well. Adjustment of the microswitches are the same for both units even though their operation is opposite (contacts of RA-43-B microswitch are normally open while those of the RA-43-A are normally closed). *Voltages involved with these rectifiers are relatively high and can prove fatal to maintenance personnel unless extreme care is taken to make sure the input power is disconnected before any servicing is begun.* Even with the input power disconnected, shock through the discharge of capacitors may be experienced unless care is taken. Slight snock caused by radio frequency bypass capacitors may be eliminated by grounding the metal cabinet.

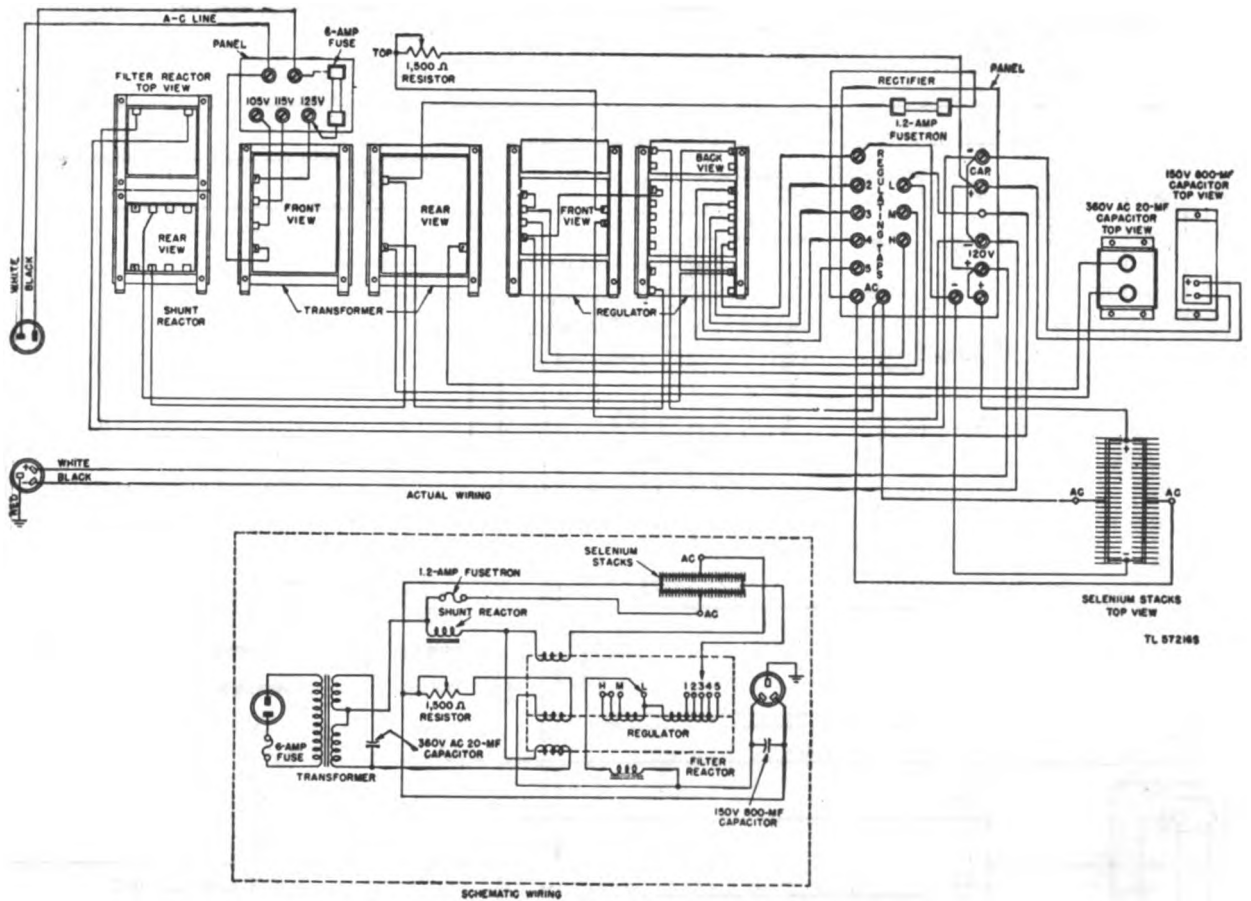
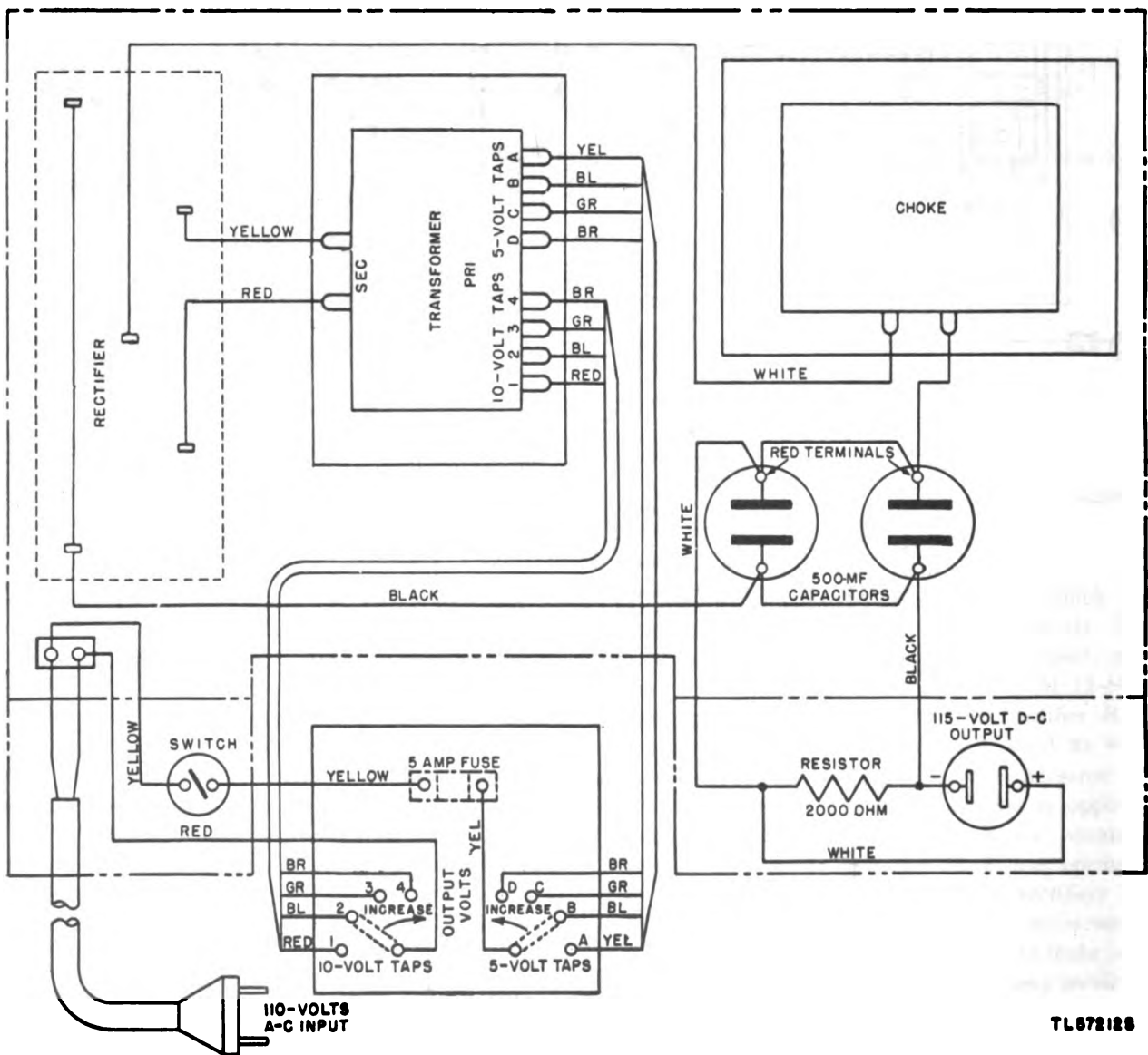
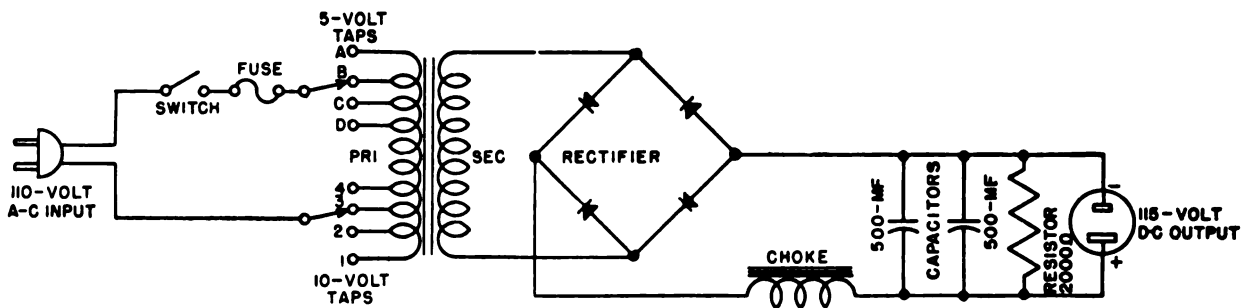

Figure 225. Wiring and schematic diagrams of rectifier REC-13.



TL572128

Figure 226. Wiring and schematic diagrams of rectifier RA-37.

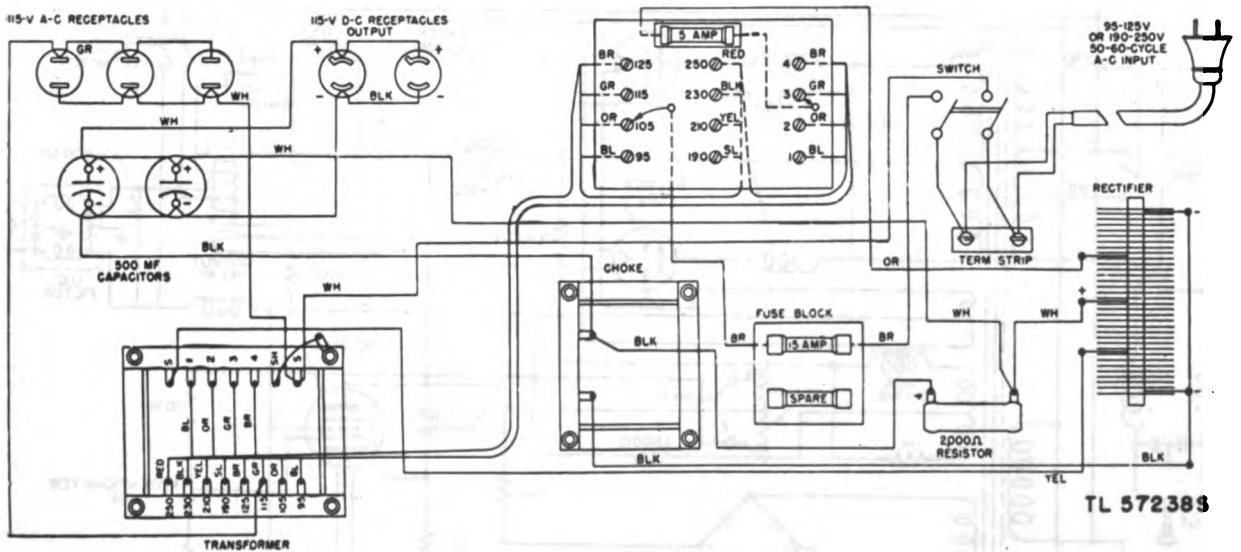
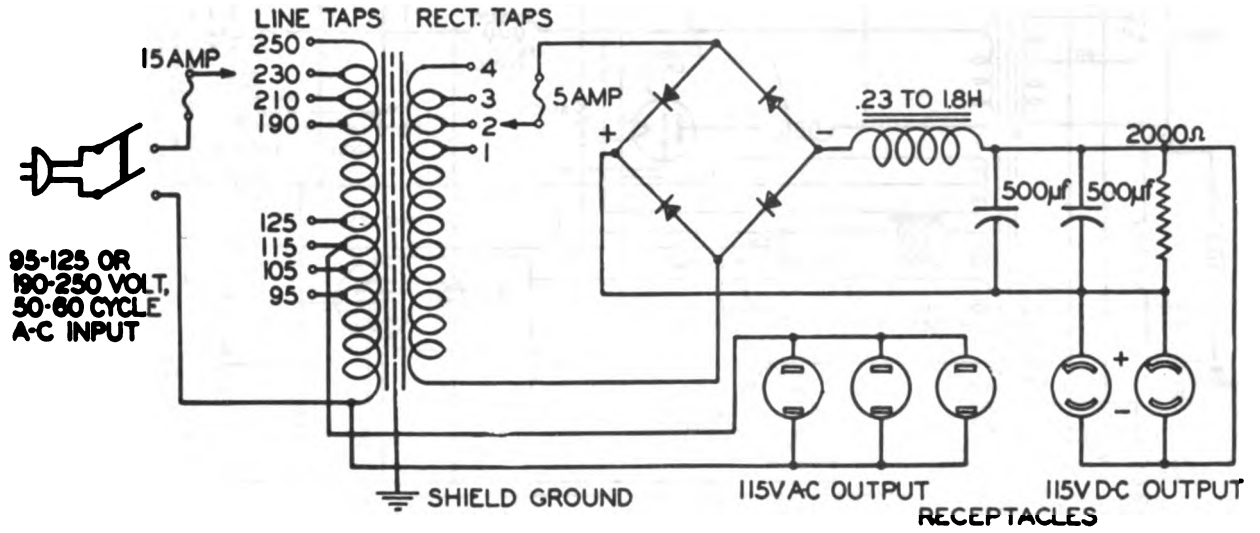

Figure 227. Wiring and schematic diagrams of rectifier RA-87.

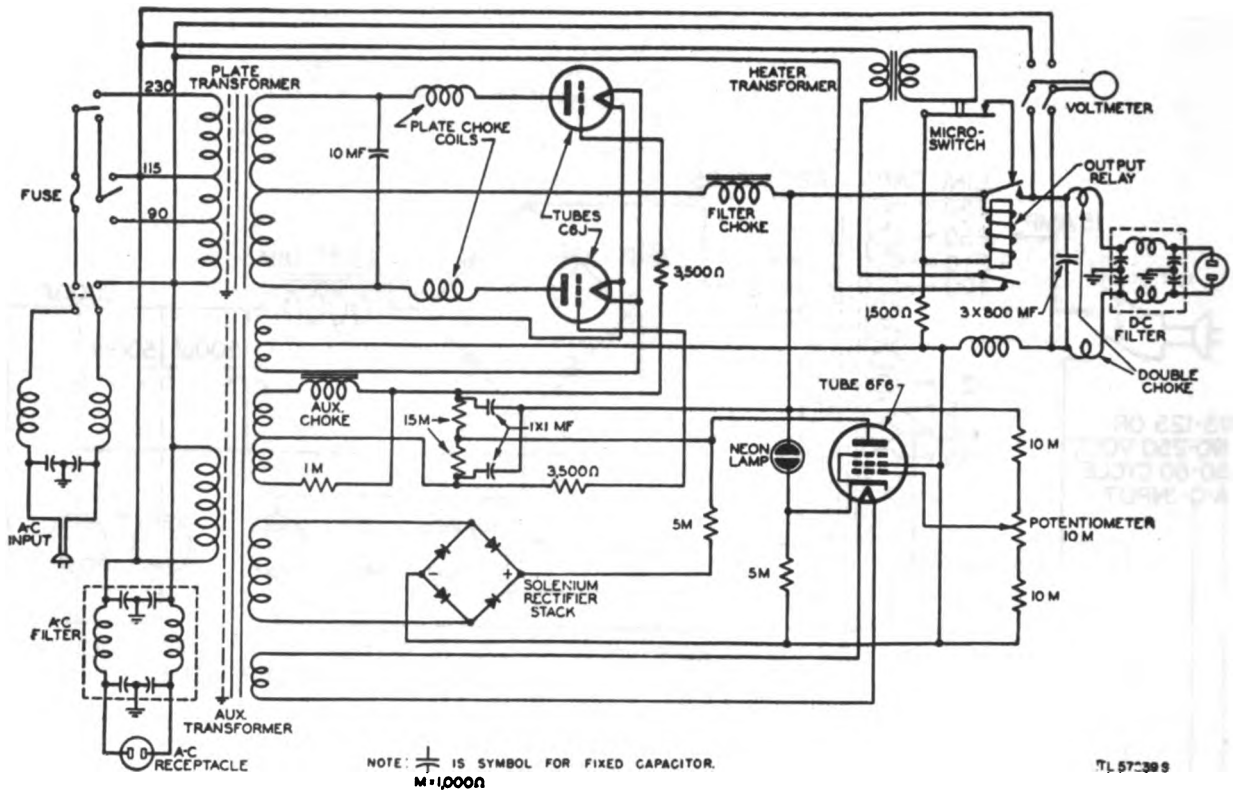

Figure 228. Schematic diagram of rectifier RA-43-A.

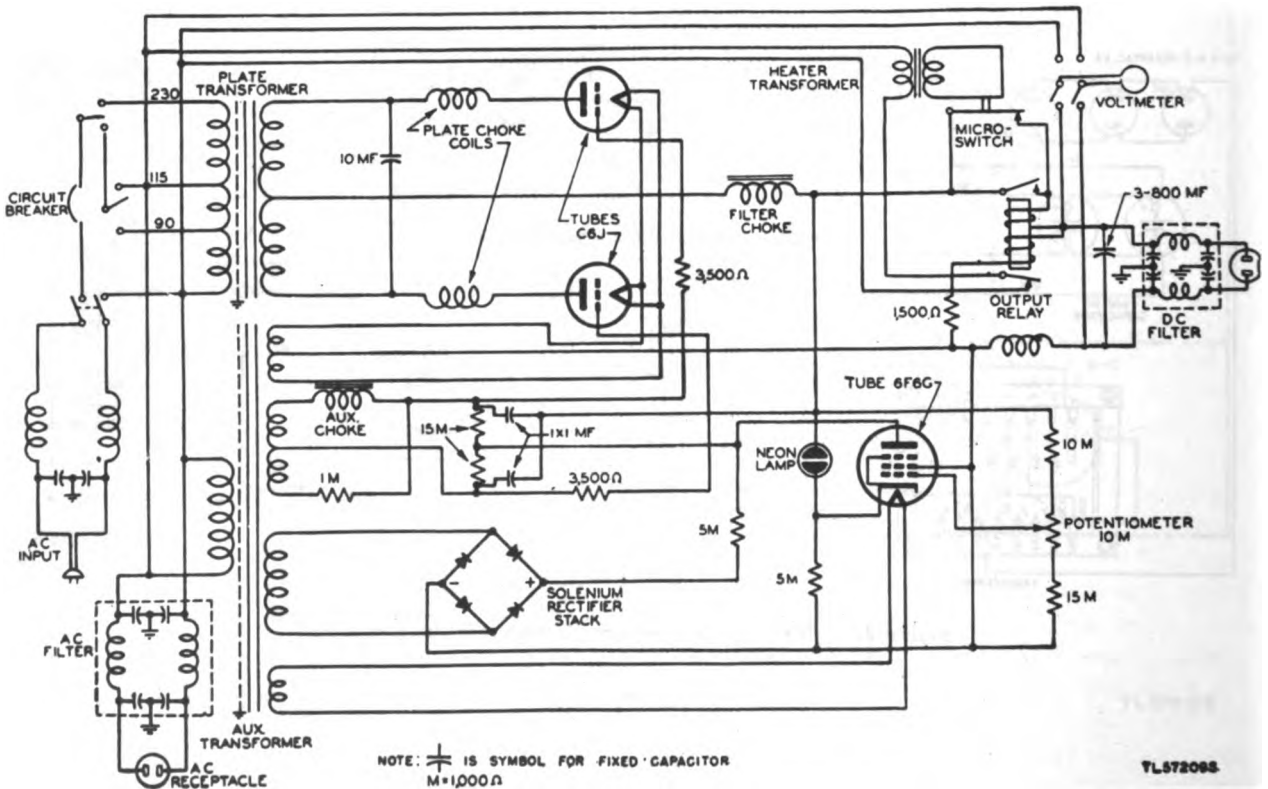

Figure 229. Schematic diagram of rectifier RA-43-B.

CHAPTER 4

RADIO TELETYPE EQUIPMENT

Section I. TELETYPEWRITERS TT-10/FG AND AN/TGC-3

138. Teletypewriter TT-10/FG and AN/TGC-3

a. DESCRIPTION. Teletypewriter TT-10/FG was formerly known as Teletypewriter Subscriber Set 132A2. Teletypewriter AN/TGC-3 was formerly known as Teletypewriter Subscriber Set 133A2. These sets are comprised of a receiving-only typing reperforator, transmitter distributor, and a metal table containing circuit components and rectifier and control elements such as keys, switches, etc. The tops of the tables are arranged for mounting the typing reperforator and transmitter distributor. Messages are received on tape in both printed and perforated form. This and other perforated tape may be used for sending and receiving in conjunction with radio teletype equipment and may be used for sending and receiving from a 131-type subscriber set or another Teletypewriter AN/TG3 or Teletypewriter TT-10/FG. Normally, Teletypewriter TT-10/FG is used only with radio teletype equipment. Teletypewriter TT-10/FG and Teletypewriter AN/TGC-3 are very similar in operation and appearance, and the following information is applicable to both unless otherwise specified. The 131-type subscriber set is part of code room equipment and does not directly concern the teletypewriter mechanic. It will not be covered, therefore, in this section. The typing reperforator and transmitter distributor used with Teletypewriter TT-10/FG and Teletypewriter AN/TGC-3 are similar to the typing reperforator and transmitter covered in paragraphs 37 through 65. The necessity for outlining their mechanical operations and adjustments is thereby eliminated.

b. CONSTRUCTION AND OPERATION. The tables of Teletypewriter TT-10/FG and Teletypewriter AN/TGC-3 are steel with a black wrinkle finish. The transmitter distributor is positioned by means of a mounting plate fastened to the top of the table at the left and can be mounted in only one position.

The typing reperforator, however, can be mounted so that the tape emerges either toward the front of the unit or toward the transmitter distributor. The latter position is generally used when messages are to be retransmitted directly. Under other circumstances the former position is to be desired inasmuch as it gives easy access to the tape for possible transmission from another set or for later transmission. When automatic retransmission is desired, a removable tape storage bin, located inside the table, may be used to good advantage. The bin is capable of storing sufficient tape to run the transmitter distributor about 20 minutes and serves to

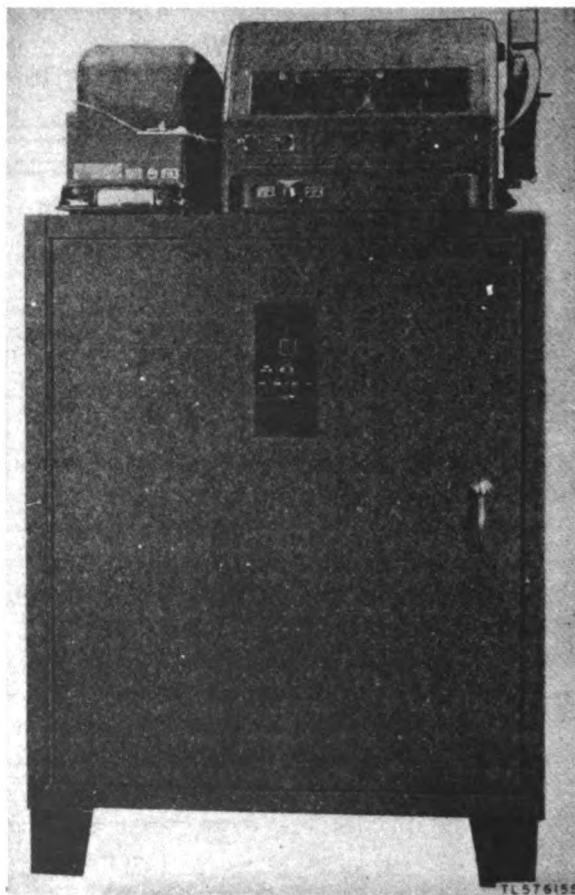

Figure 230. Teletypewriter AN/TGC-3

hold the tape in such a way as to prevent tangling as the tape is being withdrawn by the transmitter distributor. A main power switch is provided on the table top which is arranged so that the transmitter distributor may be stopped, even though the typing reperforator remains running. Teletypewriter AN/TGC-3 has its own control switch. Its table also has keys for controlling the radio teletype equipment when it is used on radio teletype circuits. These keys are not mounted on the table of Teletypewriter TT-10/FG. The tables are arranged so that a local test key, fustats, power receptacles, and terminal strips are accessible from the front. Both tables and their interior apparatus are moisture-resistant. Teletypewriter AN/TGC-3 is illustrated in figure 230.

139. Transmission Features

a. RADIO OPERATION. Teletypewriters TT-10/FG and AN/TGC-3 are commonly used to receive teletypewriter impulses from radio receiving equipment and to transmit teletypewriter impulses to radio transmitting equipment. The radio teletype equipment, in turn, sends and receives spurts of radio frequency that correspond to the marking and spacing impulses. This operation is somewhat similar to carrier operation on wire lines except that a spurt of radio frequency is transmitted for a spacing signal as well as for marking. The frequency transmitted for a marking signal is, of course, different from that transmitted for a spacing signal. Figure 231 is a block diagram of this operation. Operation to radio teletype equipment may be neutral, half or full duplex, or polar, half or full duplex. Two complete circuits are necessary for either half or full duplex when operation is to radio teletype equipment. The radio teletype transmitter is ordinarily located some distance from the associated receiver and a frequency shifter is located at the transmitter site. The frequency shifter receives the impulses from the subscriber set into a polar relay. This polar relay controls an electronic circuit in the shifter that causes two separate radio frequencies to be generated. One frequency is generated when the relay is operated to the marking contact and the other frequency is generated upon the reception of a spacing impulse. The power generated by the frequency shifter is too low for transmitting; it is necessary, therefore, to connect the shifter to a transmitter. The transmitter increases the power to a value that is suitable for transmission and may also multiply the frequency output of the shifter. This allows the frequency to be controlled at both the

transmitter and the frequency shifter. From the transmitter, the impulses are sent to a rhombic antenna which is highly directional and is pointed toward the distant radio teletype receiver. The two frequencies transmitted are 850 cycles apart and are transmitted to two receivers at the receiving station. Each receiver is tuned to receive both marking and spacing impulses. These receivers are connected to individual rhombic antennas that are located far enough apart that they will not pick up the same disturbances and therefore will not be affected at the same instant. This system of widely separating the antennas is known as *space diversity*. The outputs of both receivers are connected to Radio Teletype Terminal Equipment AN/FGC-1, which has two identical channels, one for each receiver. Each channel circuit has a system of sharply tuned filters that separate the marking and spacing frequencies. Each of these frequencies is then rectified separately and, therefore, becomes a d-c impulse. These impulses, both marking and spacing from each channel, are connected by metallic conductors to the proper windings of a 255-type polar relay. That is, the conductors that carry the marking signals from each channel are connected in parallel to the winding of the polar relay that will cause the armature to move to the marking contact. The conductors carrying the space impulses are connected to the winding that causes the armature to move to the spacing contact. By connecting the two channels in parallel onto one winding, the chances for errors caused by distortion are greatly reduced because two marking or two spacing signals are fed to the relay at the same time. Should one impulse be distorted because of magnetic disturbances, static, fading, etc., the other like impulse would still cause the relay to react properly. The polar relay, in turn, transmits polar signals to Teletypewriter TT-10/FG or Teletypewriter AN/TGC-3. The relay may be wired for neutral transmission, though normally, the subscriber set will be operating polar. The resistance of the connecting leads between the subscriber sets and the radio teletype operation should not be greater than 3,880 ohms for correct operation. As far as operation of the radio teletype circuit is concerned, the only difference between half and full duplex is that for full duplex operation the transmitters are assigned different frequencies, allowing simultaneous transmission in both directions. For half duplex operation, both stations' transmitters are assigned the same frequency; as a result the receiving station's transmitter must be disconnected.

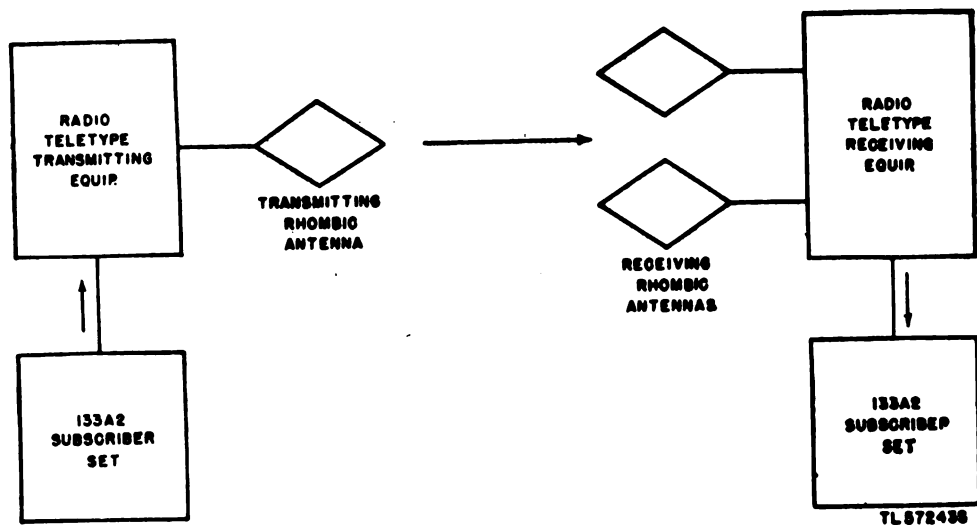

Figure 231. Operation to radio teletype equipment, block diagram.

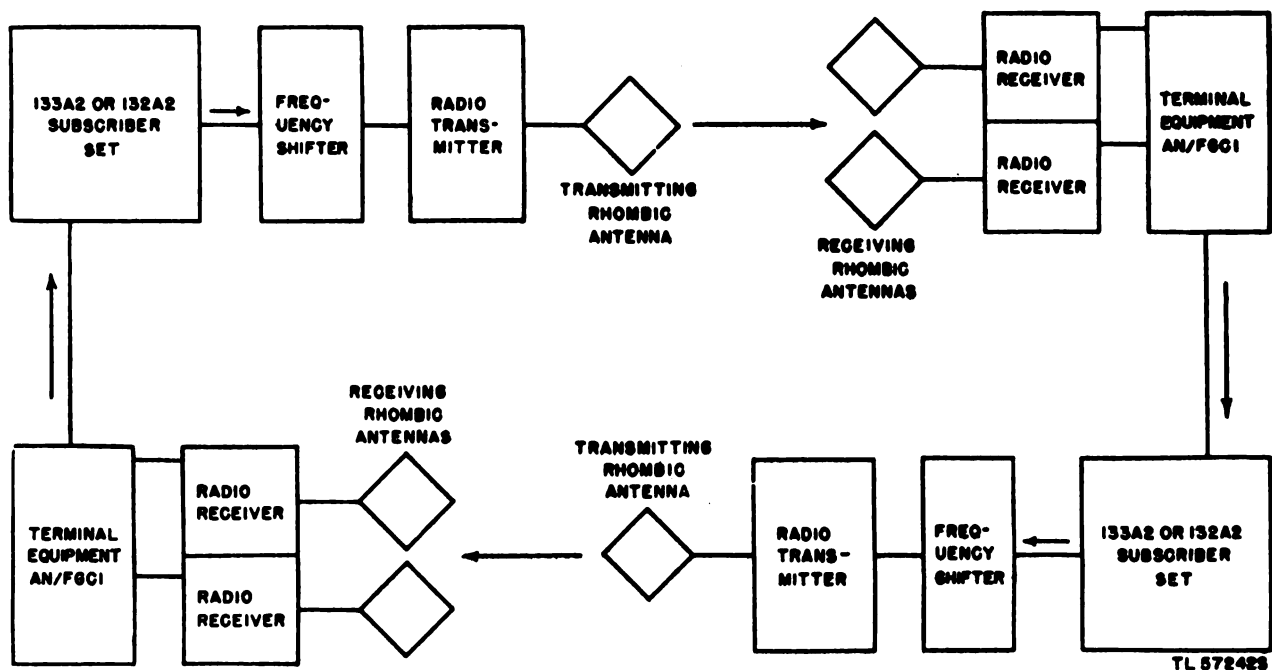

Figure 232. Complete radio teletype circuit, block diagram.

Note. In diagrams in this section, teletypewriter TT-10/FG is designated 132A2, the name it was formerly known under—and teletypewriter AN/TGC-3 is designated 133A2, the name under which it was formerly known.

b. LAND LINE OPERATION. Teletypewriters TT-10/FG and AN/TGC-3 may be used on land line (wire) circuits for interconnection. Teletypewriter AN/TGC-3 can be connected for half or full duplex operation on either polar or neutral circuits. In practically all cases, operation is on a polar basis. When Teletypewriter AN/TGC-3 is used on half duplex polar operation, a send-receive key must be posi-

tioned according to the direction of transmission. This key is not incorporated on Teletypewriter TT-10/FG. Operation of that set on a half duplex basis is, therefore, impractical. Maximum resistance for the connecting conductors is the same as for radio teletype equipment connection. Only relatively short lines (4 or 5 miles) should be connected for neutral operation and the line current must be maintained at 60 ma. Block diagrams illustrating the different types of circuit operations on land line circuits are shown in figures 233, 234, 235, and 236.

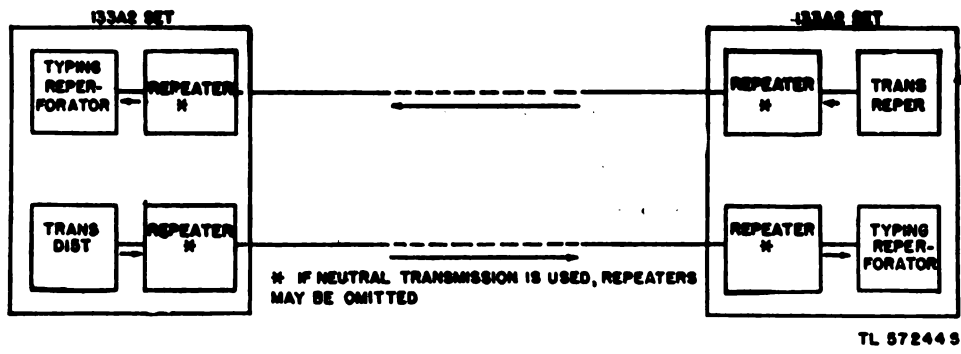

Figure 233. Two Teletypewriters AN/TGC-3 connected for full duplex operation.

c. POWER REQUIREMENTS. Teletypewriters TT-10/FG and AN/TGC-3 are arranged to operate on 95-125 or 190-250 volts of 25-60-cycle single-phase alternating current when a KS5988 power unit (rectifier) is used. Where both 105-125-volt, 60-cycle a-c power and 105-125-volt d-c power are available, the units can be equipped with a-c governed type motors for operation on the a-c power, and the relay equipment can be operated on the d-c power so that no power unit is required. If the primary supply is different from 115-volt, 60-cycle, the correct voltage is obtained from the rectifier. For example, if the input voltage is 25-cycle alternating current at 220 volts, the input leads are connected

to their proper taps to obtain proper d-c output voltage. The motor power is automatically changed to 115 volts, although the frequency is still 25 cycles. Compensation is made for this by changing the flexible lead to the proper frequency tap. This is somewhat similar to Rectifiers RA-87 and RA-43 (*), except that these rectifiers cannot be used on frequencies other than 60-cycle. Taps are also incorporated in the secondary winding of the rectifier transformer for obtaining correct d-c output voltage (120 plus or minus 3). The coarse taps (high, medium, low) change the voltage approximately 15 volts each, and the fine taps (1, 2, 3) change the output approximately 3 volts per tap. The secondary

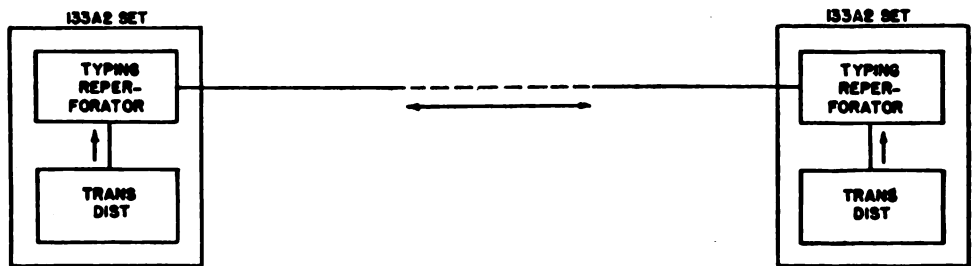

Figure 234. Two Teletypewriters AN/TGC-3 connected for neutral half duplex operation.

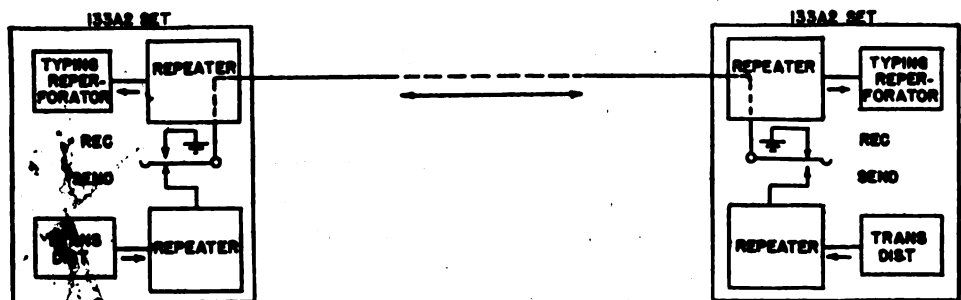

Figure 235. Two Teletypewriters AN/TGC-3 connected for half duplex polar operation.

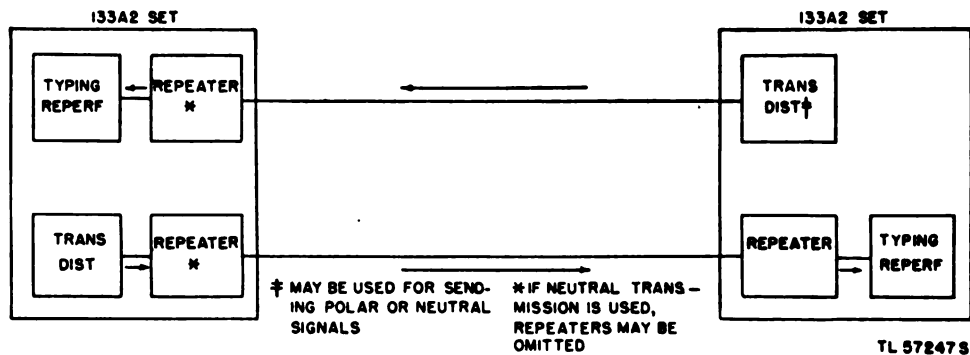

Figure 236. Teletypewriter AN/TGC-3 and Teletypewriter TT-10/FG connected for full duplex polar operation.

taps are also used to compensate for aging of the rectifier stack. Each of the subscriber sets draws approximately 300 watts.

140. Installation and Operation of Teletypewriter AN/TGC-3

a. GENERAL. Teletypewriter AN/TGC-3 should be placed in a convenient location and should be far enough away from walls and other permanent structures to allow for the opening of both the front and rear doors and to allow room at the sides of the equipment to facilitate operation. Care should also be taken to place the equipment in a location where good light is accessible. All signal, power, and ground wires should be run to the equipment in a neat and secure manner, with no loose, dangling, or surplus wire or anything that would be a safety hazard to personnel. In making connections to terminals, be careful to see that the insulation is well cleaned from the wire and that the wire has not been nicked. The wire should be wrapped around the terminal screws in a clockwise direction with no excess of bare wire on either side of the terminal screw. It is also important that the terminal screws are tight. Insulated, twisted pair, inside wire of approximately 22 gage, such as used for telephone substation work, is suitable for signal line connections. Standard rubber cord equipped with a polarized plug and plugged into a polarized outlet is suitable for primary power connection. The equipment ground wire should not be less than 14 gage and should be properly connected to a cold-water pipe if available or some other permissible ground. The transmitter distributor fits in its mounting plate on top of the table, and the typing reperforator is placed on the top right of the table with its line and power cords fed down through the opening pro-

vided in the table top. The typing reperforator can be placed with its tape chute lined up with the tape slot in the table top, if the tape produced by it is to be retransmitted by the transmitter distributor. This arrangement is shown in figure 237. If the tape produced by the typing reperforator is to be carried away, the correct position of the typing reperforator is shown in figure 230. The power unit, when used, comes in two parts. The main part consists of all of the components except the selenium varistor unit. The varistor unit is separate and mounts in the back of the table on the relay rack. Mounting brackets and bolts are provided as part of the table. The main part of the power unit is placed on the bottom of the table with the name plate facing toward the front. Figure 238 shows the main part of the power unit and figure 239 shows the varistor unit.

b. POWER AND GROUND CONNECTIONS. The a-c power cord is connected into the power outlet box of the table, and the two conductors of the cord are connected to terminals 1 and 2 of the P block located within the outlet box. The ground side of the power should be connected to terminal 1, and the hot or high side of the power should be connected to terminal 2. If the power unit is not to be used, a separate source of d-c power must be connected to terminals 3 and 4 of the P block with the negative side on terminal 3 and the positive side on terminal 4. Figure 238 shows the location of the power outlet box, and figure 240 shows the power connections. The protective ground wire connects to the ground lug which is in the power outlet box. The typing reperforator power cord should be plugged into the receptacle designated TR on the power outlet box. The power cord of the upper repeater unit connects to the receptacle, marked 120 V DC, of the table, and the power cord of the lower

repeater unit connects to the receptacle, marked 120 V DC, of the upper repeater unit. The four-pronged plug of the main part of the power unit plugs into the receptacle marked RECT on the power outlet box. The cord, on the main part of the power unit, with the three-connection female plug connects to the base marked RECT on the table. The other cord, on the power unit, equipped with the Jones plug plugs into the selenium varistor unit, thereby connecting it to the main part of the power unit. The typing reperforator magnet cord (red shell) should be connected to the RED jack of the table. The other two-conductor cord of the typing reperforator which is connected to the clutch lever contacts should not be connected to any receptacle. This is important because connecting this cord will short the d-c output of the power unit. The 350-ohm section of the resistor which is in series with the stop magnet of the transmitter distributor should be strapped out. The input voltage flexible lead of the power unit should be put on a tap which is nearest to the a-c voltage of the primary power to be used. It is also necessary that the frequency lead of the power unit be placed on the tap which corresponds to the frequency of the power supply. With the LOCAL TEST key in its TEST position, the

power switches on the table and on the typing reperforator thrown to ON, and the main power cord plugged into a suitable outlet, both motors should run. The typing reperforator should run closed. The d-c voltage output of the power unit as measured across the receptacle, marked 120 V DC, of the

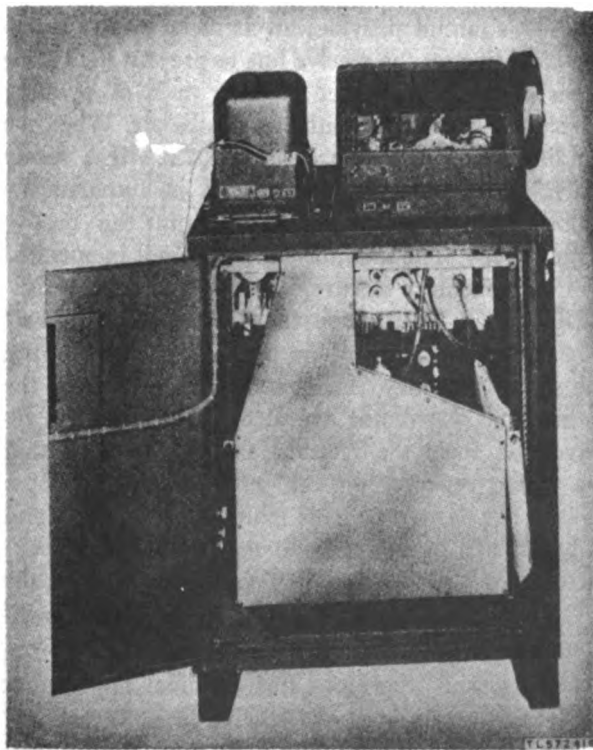

Figure 237. Teletypewriter AN/TGC-3 with front door open, showing tape bin.

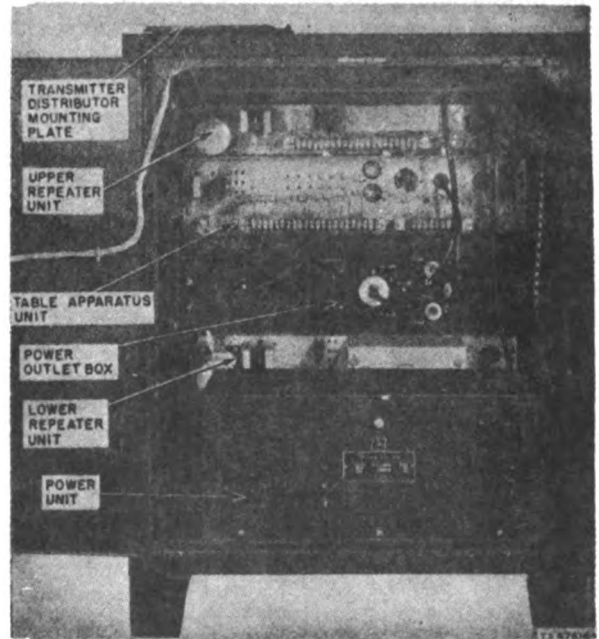

Figure 238. Teletypewriter AN/TGC-3, front interior view.

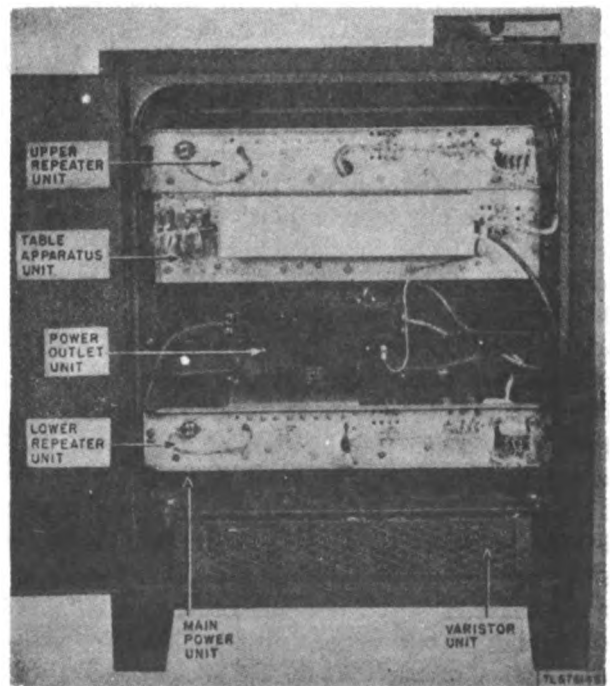

Figure 239. Teletypewriter AN/TGC-3, rear interior view.

lower repeater unit should now be 120 volts plus or minus 3 volts. This voltage can be adjusted by means of the lettered and numbered taps.

c. LOCAL TEST. With the LOCAL TEST key in its TEST position and the power turned on as described above, the selector magnet of the typing reperforator and the contacts of the transmitter distributor are in series with the proper resistance to form a local test circuit. Using a test message tape on the transmitter distributor, signals can be sent to the typing reperforator and the range can be measured. Before making this test it is necessary to set the motor speeds of both the transmitter and the typing reperforator correctly. The minimum range requirements are: test 68 and readjust 72; 68 is to be used for checking and 72 after adjustments have been made. It is desirable to have a range of 80 points if possible. Any adjustments made on the transmitter distributor or the typing reperforator should be made in accordance with the standard adjustment procedures.

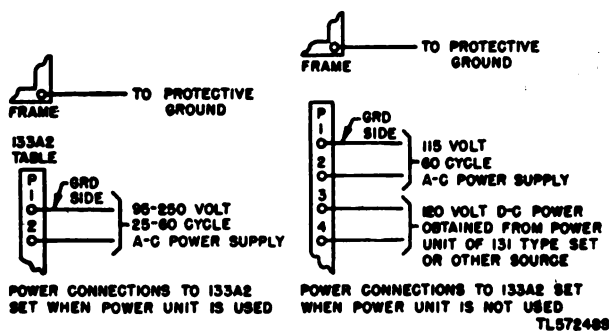

Figure 240. Power and ground connections of Teletypewriter AN/TGC-3.

d. SIGNAL LINE AND CONTROL CIRCUIT CONNECTIONS. There are four terminal blocks in teletypewriter AN/TGC-3 for signal line and control circuit connections. The B block is the terminal block of the upper repeater unit, which is the receiving repeater. The D block is the terminal block of the lower repeater unit, which is the sending repeater. The A and C blocks are both terminal blocks for the table wiring. The location of these blocks is shown in figure 238. The D block, which is in the same relative position on the lower repeater as the B block is on the upper repeater, is not visible in figure 238 because it is behind the power unit. Figure 241 shows signal line connections to terminal blocks and interconnection between blocks for various land line circuits. Figure 242 shows connections for radio teletype circuits. The purposes and operation of the transmitter control and the monitor con-

trol circuits shown in figure 242, will be covered in the following subparagraph. Both of the polar relays in the repeater units should be checked for adjustment and adjusted if necessary before operating the set for regular transmission.

e. CIRCUIT OPERATION. (1) General. The sending repeater receives neutral impulses from the transmitter distributor and sends them over the send line as polar signals. The receiving repeater can receive either neutral or polar signals from the receive line and sends neutral impulses to the selector magnet of the typing reperforator. On short lines where all neutral operation may be used for both sending and receiving, the repeaters may be omitted. The transmitter control circuit which is used only on radio circuits is for the purpose of putting the radio transmitter on the air when the SEND-MON-RECEIVE key on the 133A2 set is in its SEND position. This circuit is absolutely necessary on half duplex radio operation because the radio transmitters at both ends of the circuit use the same sending frequencies. This means that the transmitter on the receiving end must be switched off or it would interfere with the receivers picking up the signals from the sending end. The monitor lock-up control circuit is used to control the monitor lock-up circuit in Radio Teletype Terminal Equipment AN/FGC-1 at the receiver site. This circuit provides an artificial steady marking condition on the receive line to prevent the typing reperforator from either running open or printing garble when the transmitter is off the air. When the sending station comes back on the air with a steady mark, the monitor lock-up circuit is automatically unlocked and the typing reperforator can receive regular copy. The monitor control circuit is operated by the momentary closure of the nonlocking MONITOR LOCK-UP key on the 133A2 table. On half duplex radio circuits where a station's receivers use the same frequency, the signals being sent from the transmitter distributor are also received on the receive line from the receiver site. This means that the typing reperforator can monitor the sent copy. If it is not desired to have monitor copy, the A and C blocks can be strapped so that the monitor lock-up control circuit is continuously closed when the SEND-MON-RECEIVE key is in the SEND position. This prevents the monitor lock-up circuit from unlocking, and, therefore, the terminal bay cannot send any signals over the receive line. Figure 242 shows proper connections. The purpose of the local test circuit is covered in c above. Figure 243 is a schematic of the repeater unit which is the same for

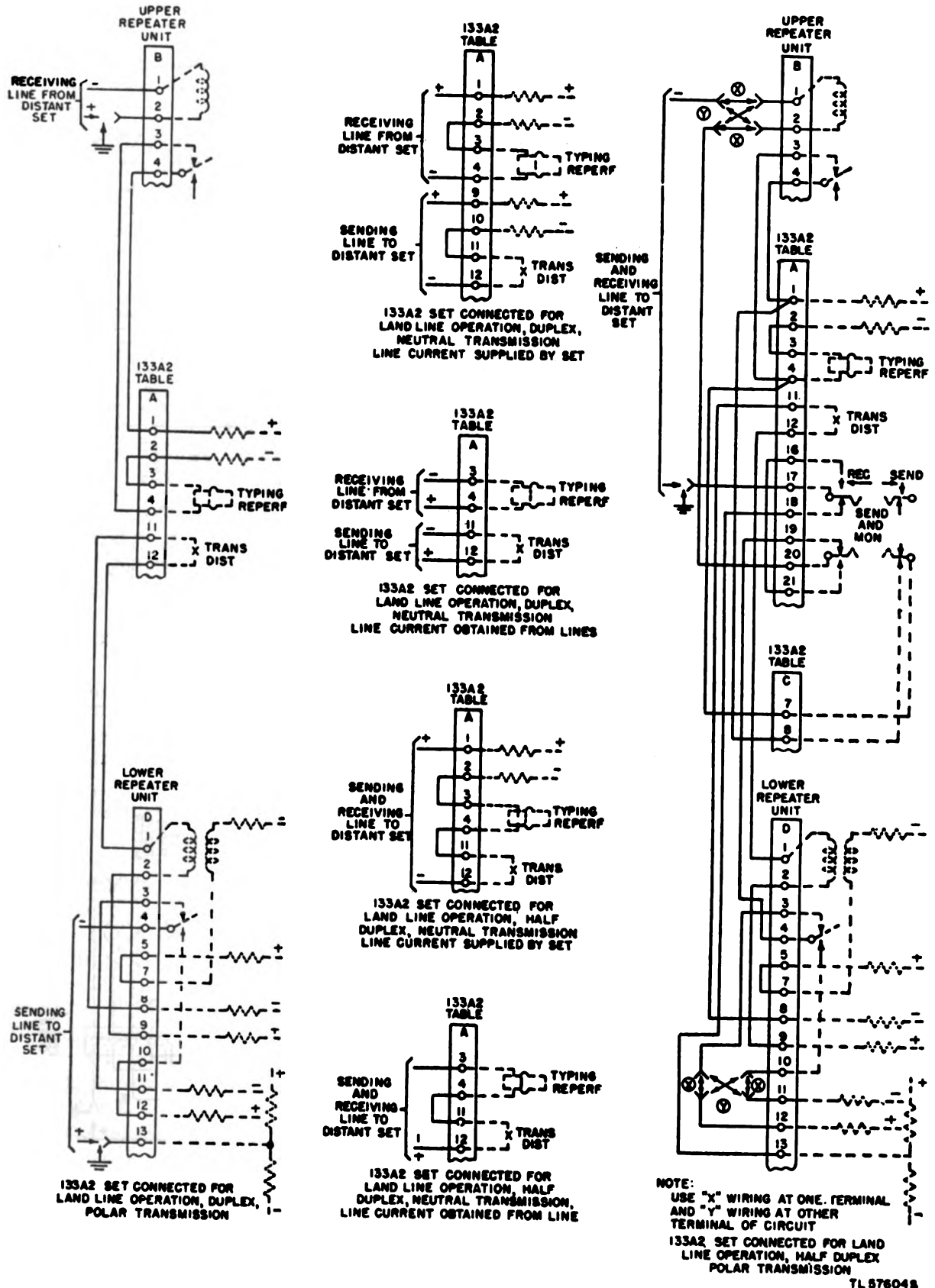

Figure 241. Connection diagram for Teletypewriter AN/TGC-3 on land line operation.

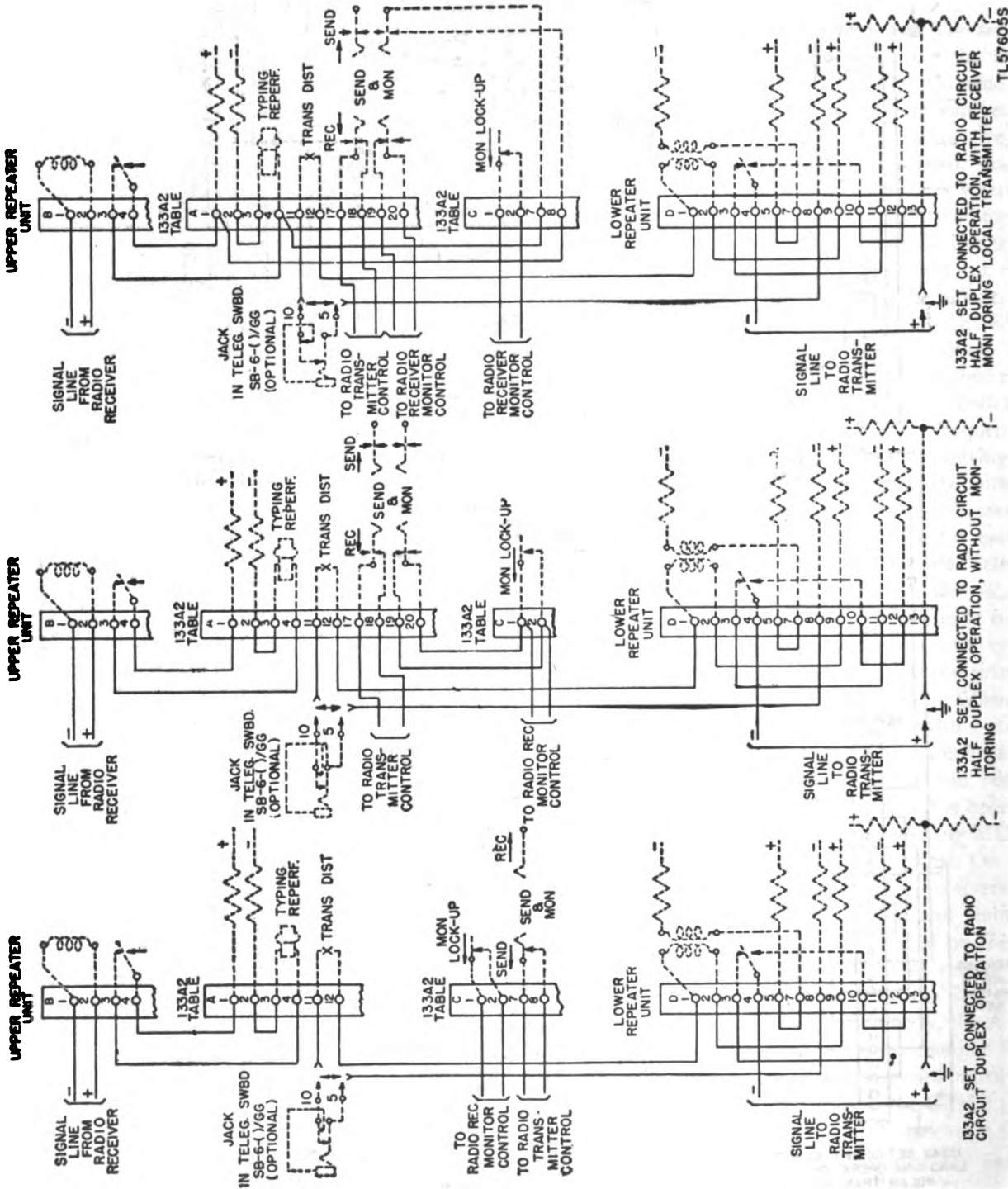

Figure 242. Connection diagram for Teletypewriter AN/TGC-3 on radio operation.

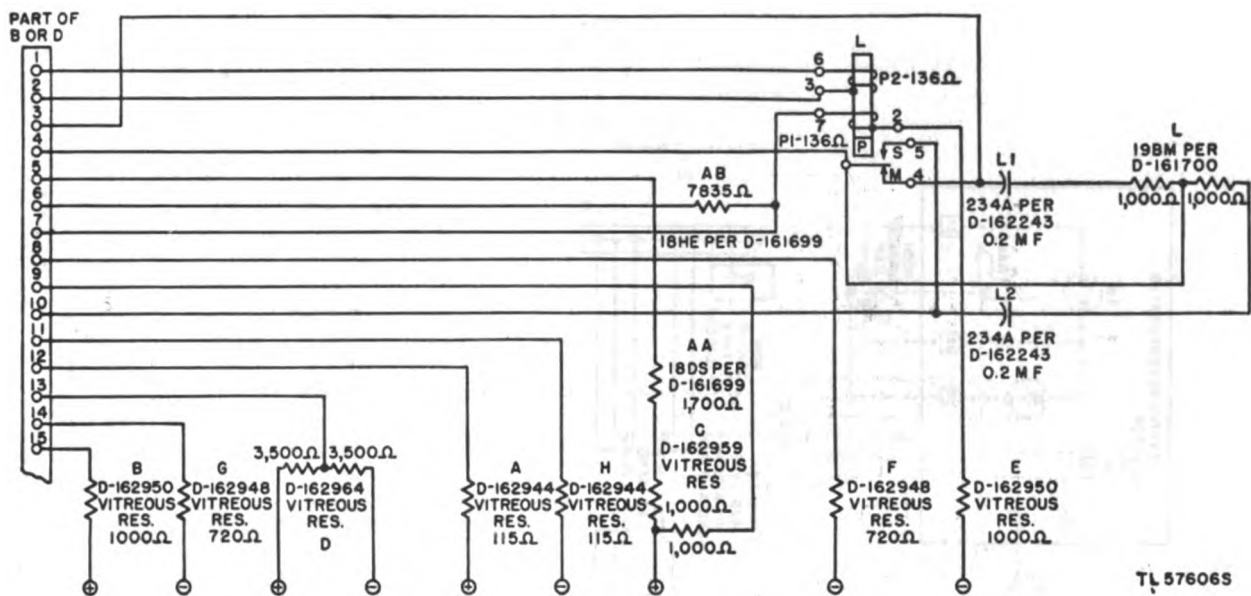

Figure 243. Repeater unit, schematic diagram.

the sending repeater or the receiving repeater. The terminal block, designated B, is on the upper repeater unit which is the receiving repeater. Terminal block D is on the lower repeater unit which is the sending repeater. Figure 244 is a schematic of the table wiring. Figures 243 and 244 should be used when tracing the various circuits as described below. Figures 241 and 242 show the interconnections between the repeater and the table circuits. Figure 245 is a theory schematic of a complete polar circuit.

(2) *Polar send circuit (mark)*. Relay L in the sending repeater circuit is operated to its marking contact by the following path: negative battery through resistor F to terminal 8 of D block, through strap to terminal 11 of A block, through made contacts of LOCAL TEST key in REG position, to terminal 3 of transmitter distributor, to terminal 2 of transmitter (T.D. marking), through the made contacts of LOCAL TEST key in REG position, to terminal 12 of A block, through strap to terminal 1 of D block, through 6-3 winding of relay L to terminal 2 of D block, through strap to terminal 9 of D block, through half of resistor C to positive battery. Relay L sends a marking impulse on a polar basis as follows: Negative battery through resistor H to terminal 11 of D block, through strap to terminal 3 of D block, through 4 and 1 of relay L to terminal 4 of D block, through one side of send loop, through 6-3 winding of receiving relay, through the other side of send loop to terminal 13 of D block, through half of voltage divider D to positive battery.

(3) *Polar send circuit (space)*. With the transmitter distributor spacing, the bias circuit of relay L operates the relay to its spacing contact. The bias circuit is as follows: Negative battery through resistor E, through 2-7 winding of relay L to terminal 7 of D block, through strap to terminal 5 of D block, through resistor AA, through half of resistor C to positive battery. Relay L sends spacing impulse on a polar basis as follows: Positive battery through resistor A to terminal 12 of D block, through strap to terminal 10 of D block, through 5 and 1 of relay L to terminal 4 of B block, through one side of send line through 6-3 winding of receiving relay, through the other side of send line to terminal 13 of D block, through half of voltage divider D to negative battery.

(4) *Polar receive circuit (mark)*. The correct resistance and battery for the polar signals for the receive line are supplied at the other end of the circuit, whether the subscriber set is receiving from another subscriber set or from Radio Teletype Terminal Equipment AN/FGC-1. The relay L in the receiving repeater receives the marking pulse on a polar basis as follows: Negative battery applied over one side of receive line to terminal 1 of B block, through 6-3 winding of relay L to terminal 2 of B block, back on the other side of receive line, through half of the voltage divider to positive battery at the terminal equipment or other subscriber set. The typing reperforator selector magnet is operated to mark by the following path: Positive battery through resistor A to terminal 1 of the A block, through strap

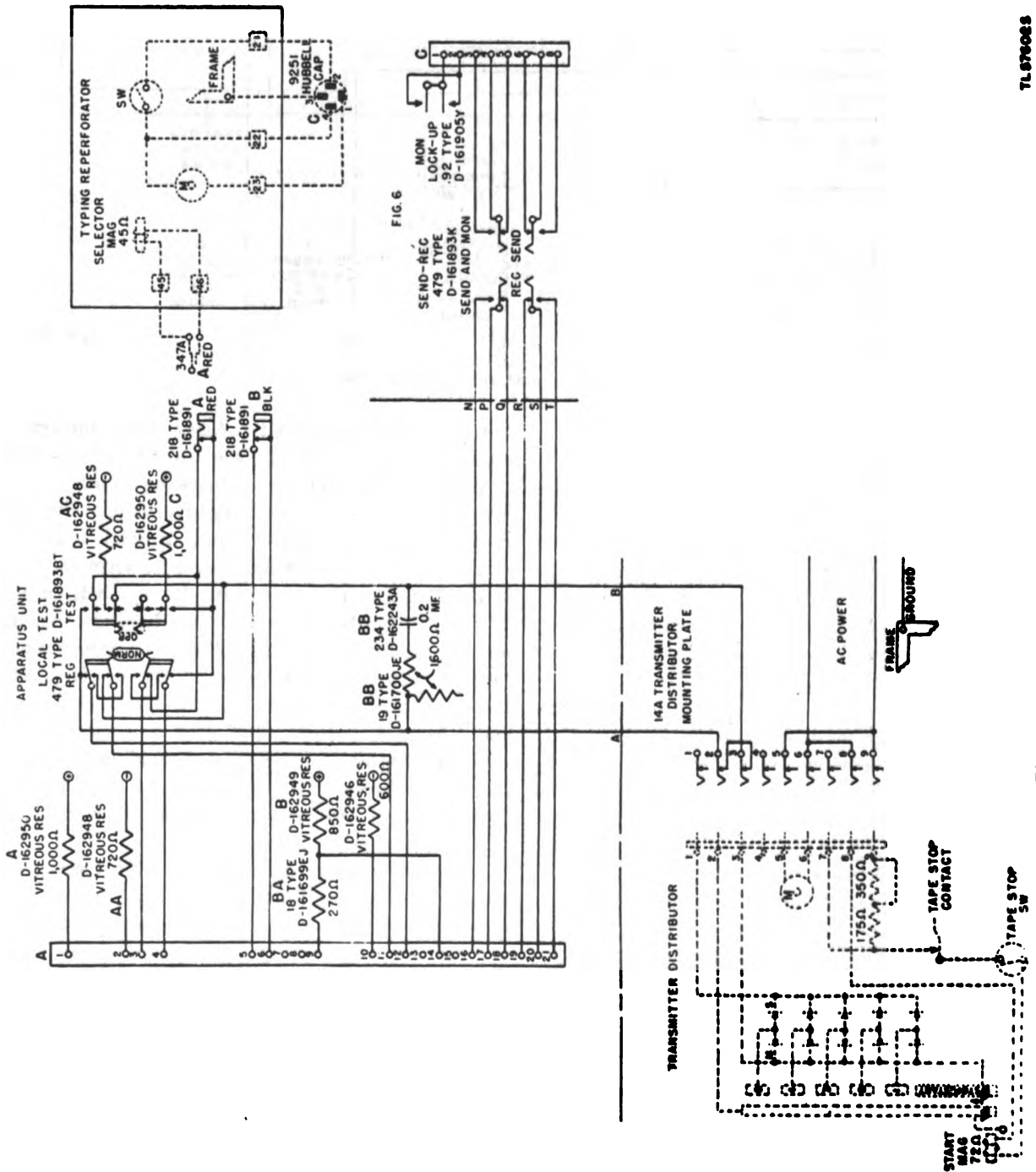

TL570683

Figure 244. Table wiring, schematic diagram.

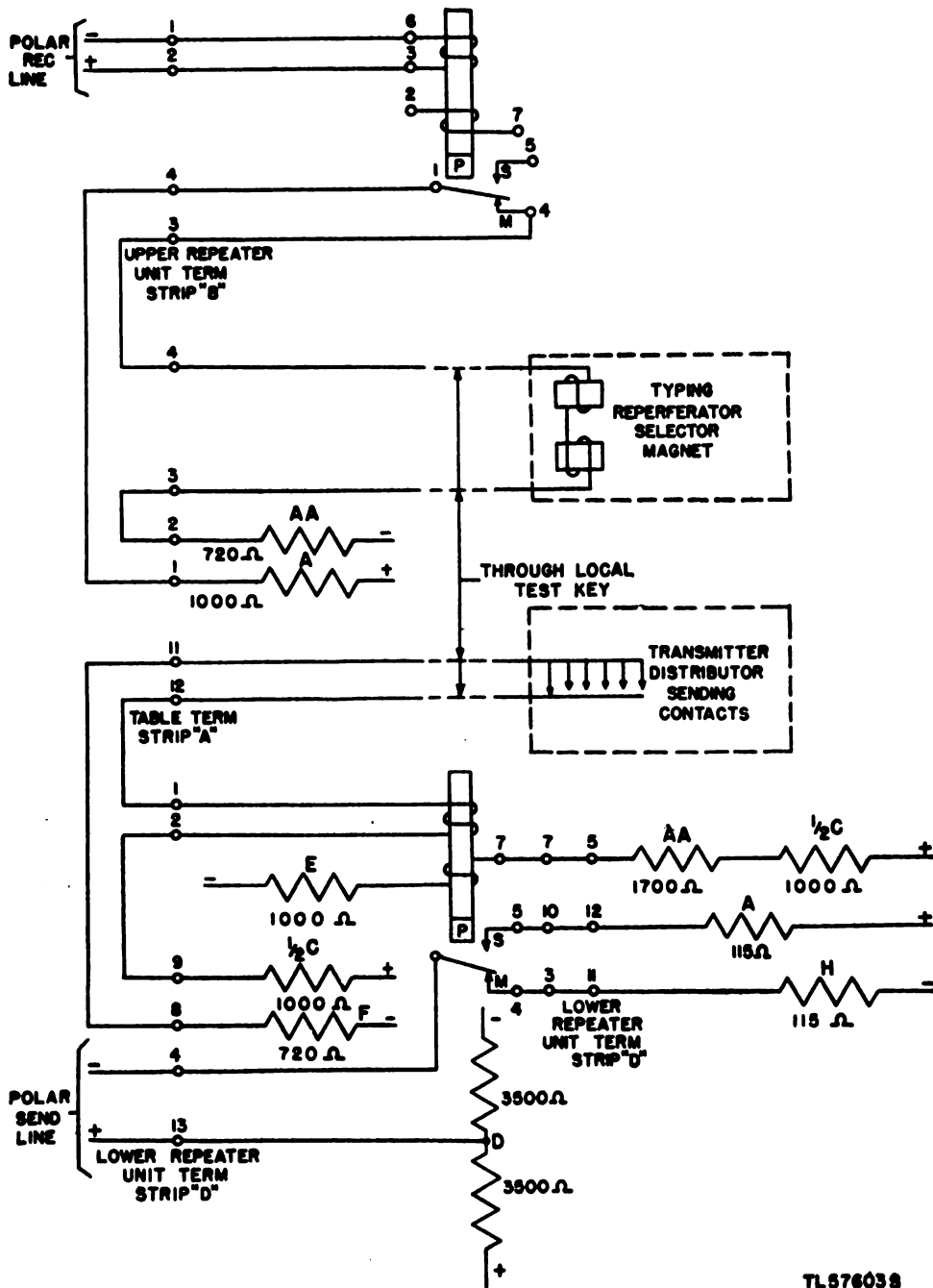

TL576038

Figure 245. Teletypewriter AN/TGC-3, theory schematic of polar operation.

to terminal 4 of the B block, through 1 and 4 of relay L to terminal 3 of the B block, through strap to terminal 4 of the A block, through made contacts of LOCAL TEST key in REG position, through sleeve of jack A, through sleeve of RED plug, through sleeve of cord, through selector magnet, through tip of cord, through tip of plug, through tip of jack, through made contacts of LOCAL TEST key in REG position to terminal 3 of the A block,

through strap to terminal 2 of the A block, through resistor AA to negative battery.

(5) *Polar receive circuit (space)*. The received current is now reversed, and relay L is therefore operated to its spacing contact. This breaks the selector magnet circuit described above, and the selector magnet spaces.

(6) *Local test circuit*. The LOCAL TEST key must be operated to its TEST position for this cir-

cuit. The circuit may now be traced as follows: Positive battery through resistor C, through made contacts of LOCAL TEST key in TEST position, through sleeve of jack A, through sleeve of RED plug, through sleeve of cord, through selector magnet, through tip of cord, through tip of plug, through tip of jack, through made contacts of LOCAL TEST key in TEST position to terminal 2 of transmitter distributor, through marking contacts to terminal 3 of transmitter distributor, through made contacts of LOCAL TEST key in TEST position, through resistor AC to negative battery.

(7) *Transmitter control circuit.* This circuit requires an additional pair between teletypewriter AN/TGC-3 and the transmitter and is connected to terminals 17 and 18 of the A block on the teletypewriter set. When the SEND-MON-RECEIVE key is in its SEND position a short is placed across terminals 17 and 18 of the A block, through the made contacts of the key. This causes the radio transmitter to put its carrier on the air. When the key is in its RECEIVE position, the short is removed and the transmitter is off the air.

(8) *Monitor lock-up control circuit.* This circuit requires an additional pair between the teletypewriter and the receiver site. This pair of wires connects to terminals 1 and 2 of the C block. When the MON-LOCK-UP key on the teletypewriter is pressed in, there is a short applied across terminals 1 and 2 of the C block. This operates the monitor lock-up circuit in Radio Teletype Terminal Equipment AN/FGC-1. The key is a nonlocking type to provide a momentary closure, which is required to operate the circuit normally. If continuous monitor lock-up is required to prevent monitoring on half duplex operation, terminals 1 and 2 of the C block should be strapped to terminals 19 and 20 of the A block. This will cause a continuous short on the monitor lock-up pair when the SEND-MON-RECEIVE key is in the SEND position.

141. Installation and Operation of Teletypewriter TT-10/FG

a. *GENERAL.* All of the general information for Teletypewriter AN/TGC-3 found in paragraph 140a applies to Teletypewriter TT-10/FG.

b. *POWER AND GROUND CONNECTIONS.* The a-c primary power cord is connected to the power outlet box of the table, and the conductors are connected to terminals of the A block which is located in the power outlet box. Figure 246 shows the location of the power outlet box, and figure 247 shows the vari-

ous power connections which may be used. If direct current is used as the only source of primary power, it should be from 105 to 125 volts and must be connected to terminals 1 and 2 of the A block as shown in figure 247. In this case d-c shunt motors are used, and no power unit is necessary. The power patching cord, which is supplied with the table, must, however, be connected between receptacle A of the power outlet box, and base E of the table. This furnishes d-c power for circuit operation. This patching cord must also be used when alternating current is used for motor power, but a separate source of direct current is connected to terminals 3 and 4 of the A block for circuit operation when no power unit is used. Figure 248 shows receptacle A and base E. The No. 14 protective ground wire is connected to the ground lug as it is on Teletypewriter AN/TGC-3. The various cords of the typing reperforator and power unit should be connected in accordance with figure 248. The input voltage and frequency leads of the power unit, when used, should be connected to the proper taps according to the source of a-c power used. The d-c output of the power unit should be 120 volts, plus or minus 3 volts, and should be checked under the following conditions: the a-c power cord plugged into a suitable outlet, the power switches on the table top and on the typing reperforator ON, the LOCAL TEST key in its TEST position, the SYNC key on the front door of the table in its OUT position, the FAST potentiometer to 0, and the SLOW potentiometer to 10. The d-c output of the power unit can be adjusted by means of the lettered and numbered taps.

c. *LOCAL TESTS AND ADJUSTMENTS.* The operating speeds of the motors should be checked and adjusted, if necessary, before proceeding with other tests. It is also necessary that the receiving relay R be properly adjusted before making further tests. With the LOCAL TEST key in TEST position, and the SYNC key in the OUT position, the R relay is connected to the transmitter distributor and the synchronizer circuit is inoperative. With the circuit in this condition, a test tape should be placed on the transmitter distributor and signals sent to the typing reperforator. The orientation range of the typing reperforator can now be taken and the range finder can be set at the midpoint. The range requirements are test 68 and readjust 72. To check the operation of the clutch lever contacts, throw off the power switch of the typing reperforator, and place the SYNC key on its OUT position and the TIMING

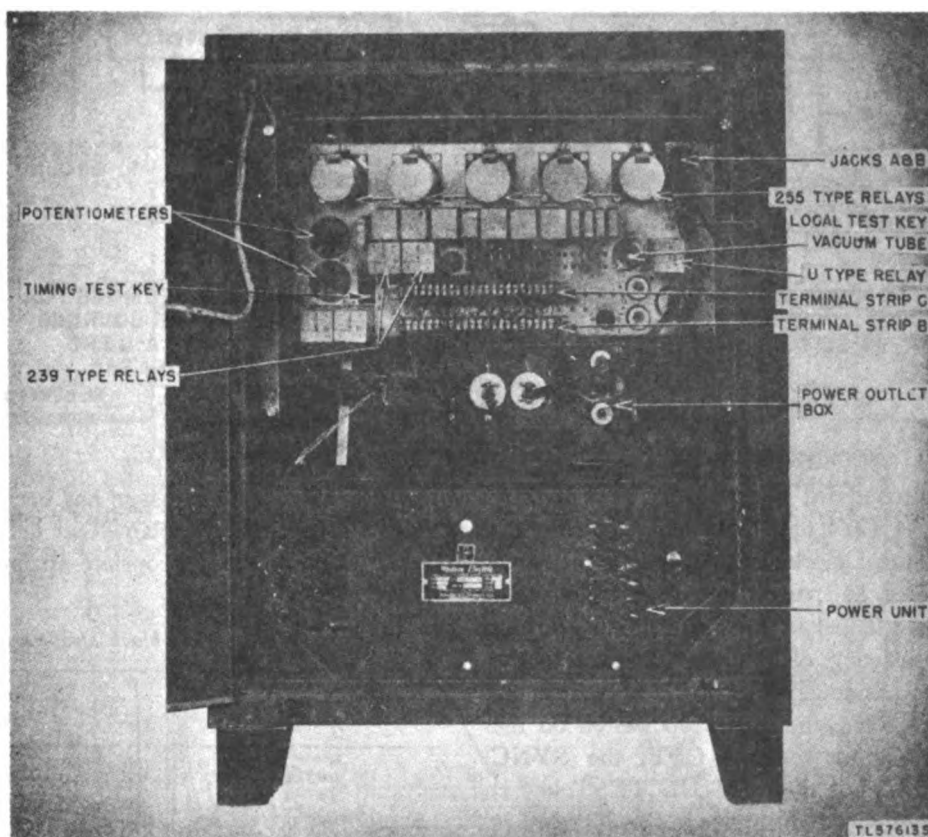

Figure 246. Teletypewriter TT-10/FG, front interior view.

TEST key (fig. 246) on its FAST position. With the motor of the typing reperforator turned manually until the clutch lever contacts are closed, relays FS, SL, L, and MK should operate to their No. 4 (right-hand) contacts, and relays SP and TR should operate to their No. 5 (left-hand) contacts. With the TR relay blocked on its No. 4 contact and the typing reperforator motor turned until the clutch lever contacts open, relays FS, SL, L, and MK should remain on their No. 4 contacts. When relay TR is released to its No. 5 contact, relays L and MK should operate to their No. 5 contacts, and relays FS and SL operate to their No. 3 contacts. Relays SP and TR should reoperate to their No. 4 contacts. The FAST and SLOW potentiometers have to be adjusted so that the FS and SL relays operate at the correct times. This is necessary in order that the artificial stop and start are of correct lengths and occur at the correct times. Before the potentiometers are adjusted they should be initially set at 5. The first step in adjusting the potentiometers is to check the typing reperforator to make certain that it operates 368 opm. This can be done by

sending test signals from the transmitter distributor to the typing reperforator, with the set on local test and the synchronizer out as described above. With the typing reperforator operating in this manner, the received tape should be torn off at the tape knife and at the same time, timing should be started with a stop watch or a watch with a sweep second hand. At the end of 60 seconds, the tape should be torn off again. The piece of tape thus detached from the typing reperforator should be 36.8 inches long (368 opm). It is extremely essential that the motor speeds be correct for this test. It may be necessary to repeat the test in order to develop the proper technique in tearing the tapes, etc. The FAST potentiometer is adjusted first by throwing the tape stop switch on the transmitter distributor to OFF, operating the TIMING TEST key to FAST, and the SYNC key to REG. The R relay is now operated to steady space and the FS relay supplies artificial stop pulses. This means that the number of operations per minute of the typing reperforator depends upon the operation of relay FS. The FAST potentiometer should be adjusted so that tape torn off and meas-

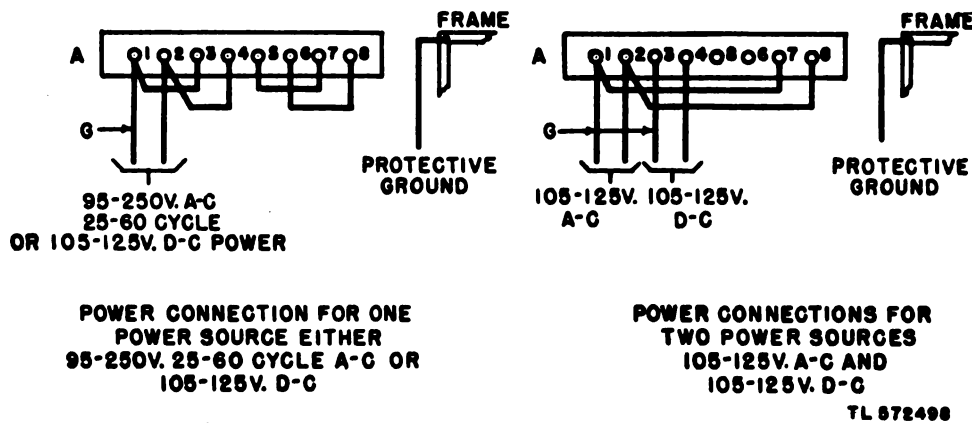

Figure 247. Teletypewriter TT-10/FG, power connections.

ured after 60 seconds of operation is from 37.2 to 37.6 inches; 37.4 (374 opm) is ideal. Turning the FAST potentiometer clockwise will reduce the number of operations, and turning it counterclockwise will increase the number of operations. The tearing, timing, and measuring of the tape is done in the same manner as previously described. To adjust the SLOW potentiometer, the tape stop switch on the transmitter distributor remains OFF, the SYNC key stays in REG, but the TIMING TEST key is operated to its slow position. Now the R relay is operated to steady mark, and relay SL causes artificial start pulses to be supplied to the typing reperforator. The SLOW potentiometer should be adjusted so that tape now measured is from 36.0 to 36.4 inches for 60 seconds operation; 36.2 (362 opm) is ideal. Here again turning the potentiometer clockwise decreases the number of operations and vice versa. Remember that the transmitter distributor is not operating during these adjustments. For the location of the FAST and SLOW potentiometers, and the TIMING TEST key, see figure 246. The SYNC key is on the front door of the table. The operation of the circuit is explained in *e* below. With the LOCAL TEST key restored to its REG position and the TIMING TEST key restored to its REG position, the set is ready to be connected to the send and receive lines for regular operation.

d. SIGNAL LINE CONNECTIONS. There are two terminal blocks in the table for the connection of signal lines and associated strapping. One block is designated B and the other block is designated C. Figure 246 shows the location of these blocks. Figure 249 shows signal line connections and strapping for various types of operation. Terminals 6, 7, 8, 9, and 10 of the C block are strapped according to the number of operations desired for the synchronizer

to time out after a message has been received. The time out feature is explained in detail in *e* below. Table I shows the appropriate strapping for the C block.

Table I. C block strappings.

Desired No. of characters before tie out	Strap terminal CIO to terminals
20	C6, C7
25	C7, C8
30	C6, C7, C8
35	C7, C8, C9

e. CIRCUIT OPERATION. (1) *General.* The send circuit provides either neutral or polar sending directly from the transmitter distributor. The transmitter distributor can be switched to either one of two send loops, if required, by the STATION key. The key has two positions: STA 1 and STA 2. Figure 249 shows the connections for both send lines. When the transmitter distributor is sending on one send line, there is a steady marking condition applied to the other line. The receive circuit receives either neutral or polar signals on the receiving relay R. The relay in turn repeats the signals on a neutral basis to the typing reperforator. The operation of the local test circuit has already been explained in *c* above. The synchronizer circuit has two important functions. It insures, as far as practicable, that the typing reperforator stays in synchronism with the signals from the sending end, when automatic transmission (transmitter distributor) is used. Loss of synchronism may cause characters to be either added or lost, which makes the deciphering of certain types of coded messages difficult. The synchronizer circuit also reduces the number of errors received caused by poor transmission

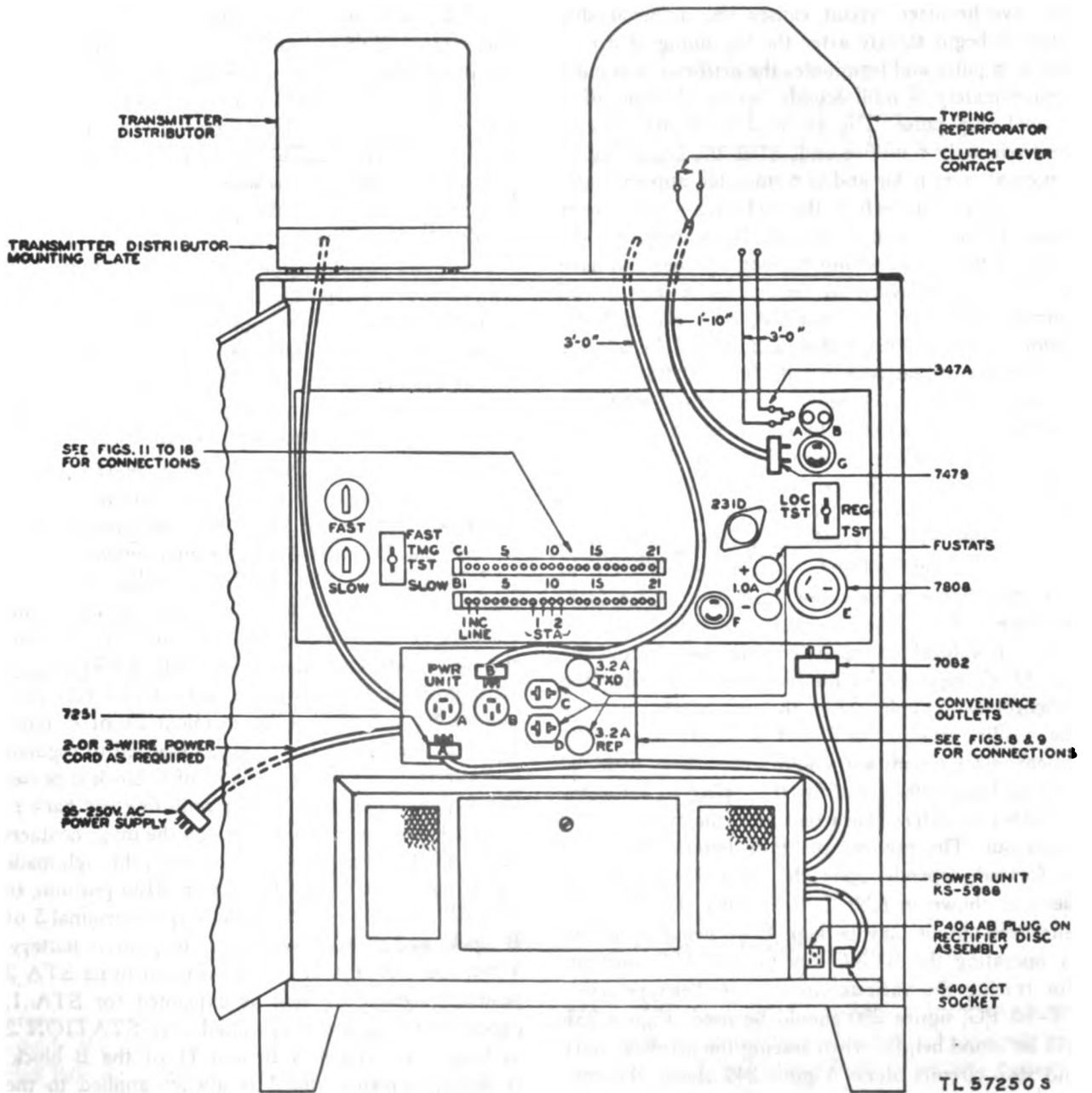

Figure 248. Teletypewriter TT-10/FG, cording diagram.

on the radio channel. Radio disturbances which affect one or more of the five selecting impulses will, of course, cause an error, but disturbances which affect only the start or stop pulse will not cause error since these pulses will be artificially supplied. The synchronizer circuit causes the artificial stop pulse to begin shortly after the beginning of a normal stop pulse and terminates the artificial stop pulse approximately 6 milliseconds before the end of a normal stop pulse. The artificial start pulse begins approximately 6 milliseconds after the beginning of a normal start pulse and is terminated approximately 2 milliseconds before the end of a normal start pulse. If the normal pulses are being received, the artificial pulses fall within the normal ones and have no effect on receiving. If either one or both of the normal pulses are not received, or received badly distorted, the artificial pulses will control the selector mechanism of the typing reperforator. For correct operation of the synchronizer circuit, the SYNC key must never be switched to REG, which would cut in the circuit, while a message is being received. The SYNC key should be operated to its REG position while Teletypewriter TT-10/FG is receiving a steady mark prior to receiving a message. The synchronizer circuit will then be automatically cut in after the reception of a few spacing impulses from the receive line. Message tapes are often prepared with a few blank character combinations before the text of the message for the purpose of cutting in the synchronizer circuit. After the end of the message the sending station will send a steady mark. The synchronizer circuit will continue to supply artificial start and stop pulses, causing the typing reperforator to perforate letters characters until the synchronizer times out. The number of these letters characters perforated depends upon the strapping of the C block as shown in table I. Remember that the synchronizer circuit may be kept from being operative by operating the SYNC key to its OUT position. For tracing the various circuits, of Teletypewriter TT-10/FG, figure 250 should be used. Figure 251 will be found helpful when tracing the artificial start and stop circuits alone. Figure 249 shows the correct strapping for different types of operation.

(2) *Send circuit, polar sending (mark)*. In this circuit negative battery is applied through resistor AG to terminal 14 of the B block, through strap to terminal 12 of B block, through made contacts of LOCAL TEST key in REG position, through terminals 3 and 2 of transmitter distributor (marking), through made contacts of TIMING TEST key in

REG position, through made contacts of LOCAL TEST key in REG position, through made contacts of STATION key in STA.1 position (key is shown in STA 1 position in figure 250), to terminal 21 of C block. From here it passes through strap to terminal 17 of C block, to terminal 8 of B block, over one side of STA 1 send line, through winding of receiving relay, back over the other side of send line to terminal 9 of B block, through made contacts of STATION key in STA 1 position, through made contacts of LOCAL TEST key in REG position to terminal 3 of B block, through strap to terminal 6 of B block, and through the positive half of voltage divider A to positive battery.

(3) *Send circuit, polar sending (space)*. Positive battery is applied through resistor F to terminal 13 of B block, through strap to terminal 7 of B block, through terminals 1 and 2 of transmitter distributor (spacing), through the STA 1 send line as described above for marking, and through the negative half of voltage divider A to negative battery.

(4) *Send circuit, neutral sending (mark)*. In this arrangement, negative battery is applied through resistor AG to terminal 14 of B block, through strap to terminal 12 of B block, through made contacts of LOCAL TEST key in REG position, through 3 and 2 of the transmitter distributor, through made contacts of TIMING TEST key in REG position, through made contacts of LOCAL TEST key in REG position, through made contacts of STATION key in STA 1 position to terminal 21 of C block (terminals 21 to 17 strapped as required to regulate line current). From terminal 17 of C block it passes to terminal 8 of B block, over send line and back to terminal 9 of the B block, through the made contacts of STATION key in STA 1 position, through made contacts of LOCAL TEST key in REG position, to terminal 3 of B block, through strap to terminal 5 of B block, and through resistor P to positive battery. When the STATION key is operated to its STA 2 position, signals are sent as explained for STA 1, except that they are transmitted over STATION 2 of line from terminals 10 and 11 of the B block. A steady marking signal is always applied to the send line not being used, regardless of the type of operation.

(5) *Receive circuit, receiving neutral signals, synchronizer out*. To switch out the synchronizer circuit, the SYNC key is operated to OUT. This closes contacts which complete a holding circuit for the N relay, so that the relay stays operated even though relay P releases. With relay N operated the syn-

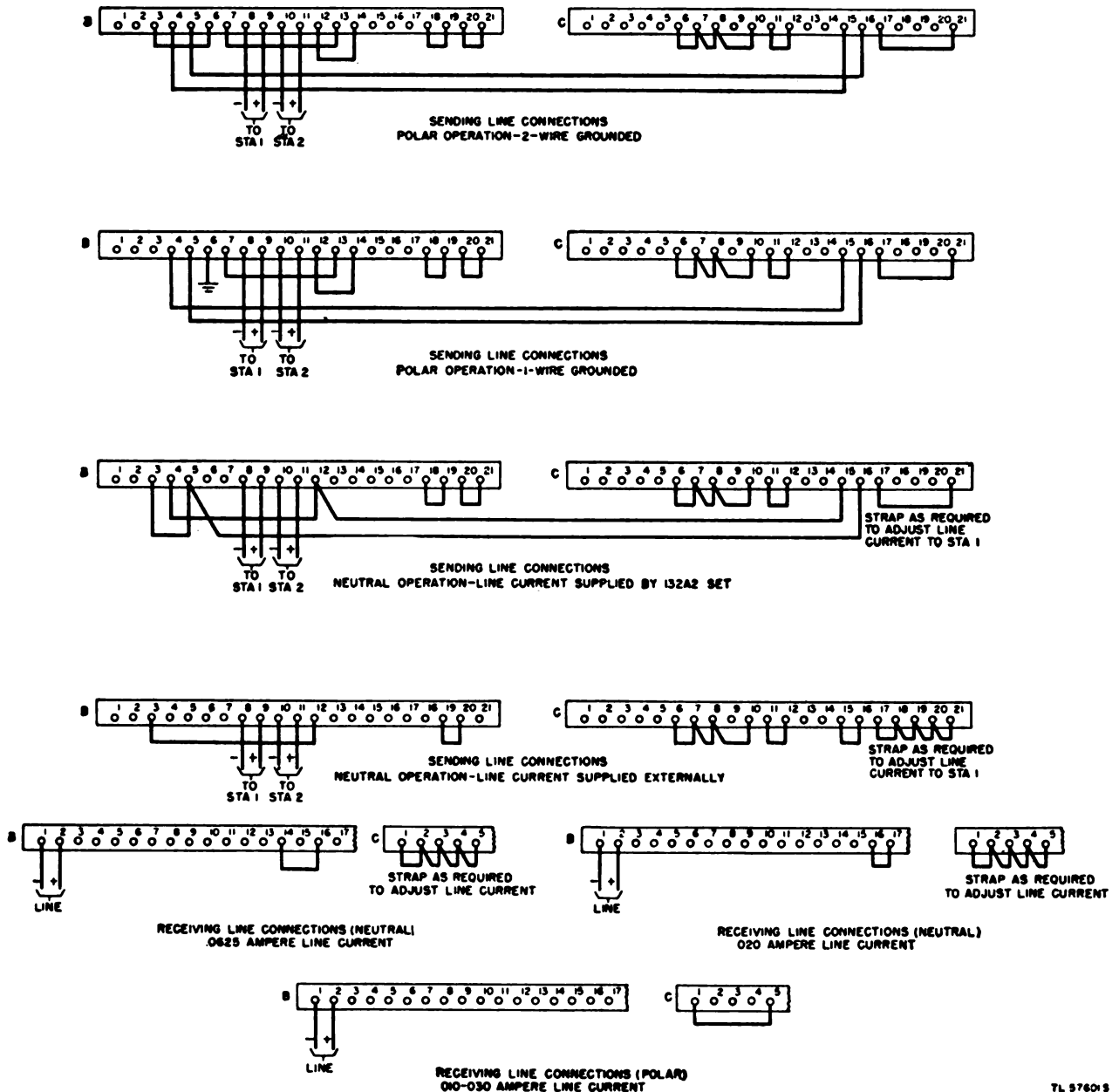

Figure 249. Teletypewriter TT-10/FG, signal line connections.

chronizer circuit relays still operate but they cannot provide the artificial start and stop pulses. The N relay holding circuit is as follows: Negative battery through resistor AK, through winding of relay N, through made contacts of SYNC key to its out position, through resistor F to positive battery. When a mark is being received from the distant end of the receive line, negative battery is applied to terminal 1 of B block, through made contacts of LOCAL TEST key in REG position, through 6-3 winding of relay R, through made contacts of LOCAL TEST

key in REG position, to terminal 5 of C block strapped to terminal 1 of C block as required, to terminal 2 of B block, and back to positive battery at the sending end.

(6) *Bias circuit for relay R.* In this circuit, negative battery is applied through resistor AG, through 2-7, winding of relay R, through made contacts of LOCAL TEST key in REG position, to terminal 15 of B block, through strap to terminal 17 of B block, and through resistor BC-K to positive battery.

(7) *Receive circuit, polar receiving.* The R relay

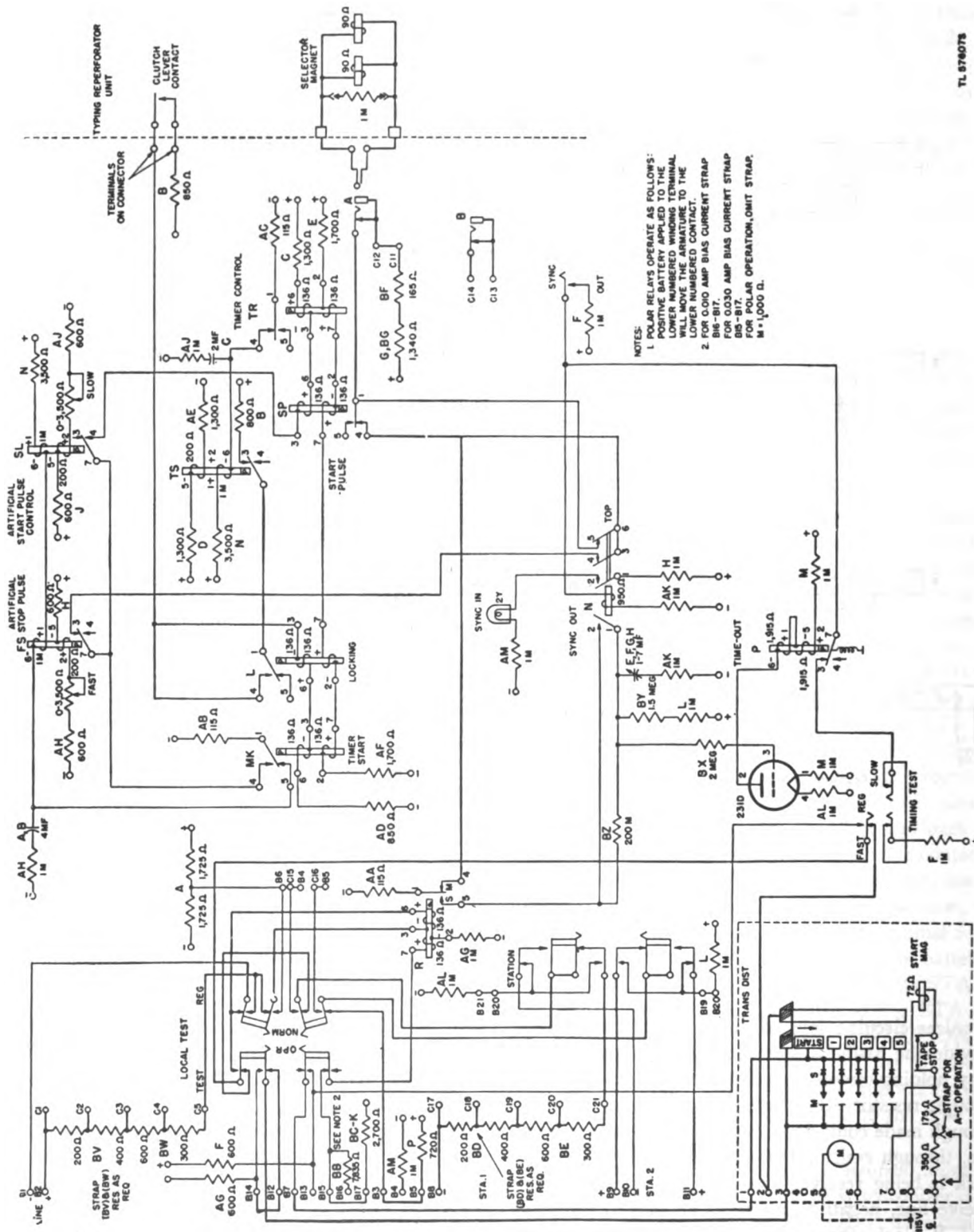

TL 876078

Figure 250. Teletypewriter TT-10/FG, theory schematic.

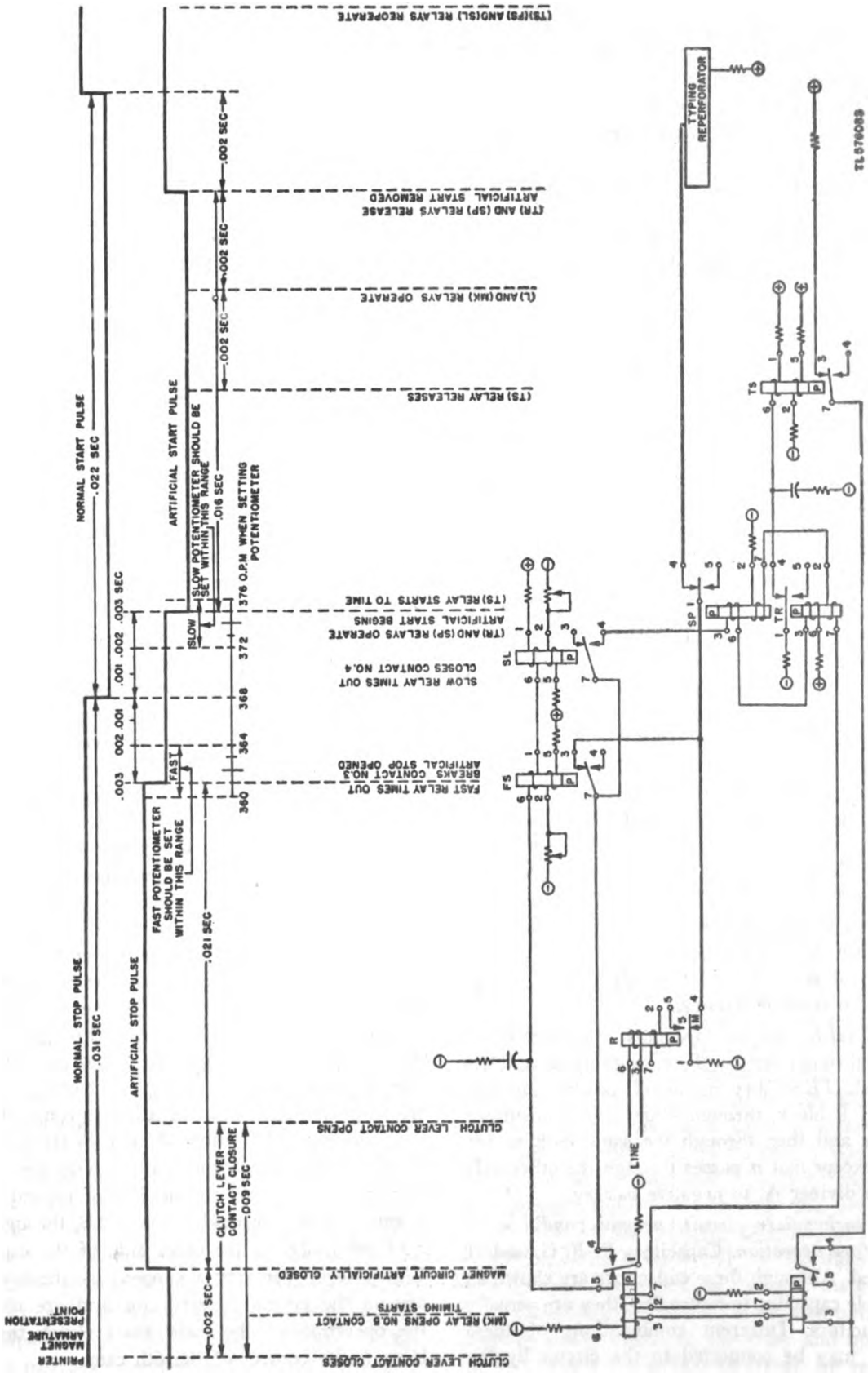

Figure 251. Teletypewriter TTT-10/FG, timing diagram.

receives polar signals over the same circuit that is used for neutral receiving as described in (5) above. The strap between terminals 1 and 17 of the B block is removed, opening the bias circuit of the relay. Terminals 15 and 1 of the C block are strapped as the polar current is regulated at the sending end.

(8) *Typing reperforator selector magnet circuit (marking)*. Negative battery is applied through resistor AA, through 1 and 4 of relay R, through 4 and 1 of relay SP, and also in a parallel path through 6 and 5 of relay N which is operated when the synchronizer is out because relay SP will not be operated to its No. 4 contact at all times. From there it passes through tip of jack A (red), through tip of plug, through tip of cord, through the selector magnets, through sleeve of cord, sleeve of plug, sleeve of jack, to terminal 12 of C block, through strap to terminal 11 of C block, and through resistors BF, BG, and G to positive battery.

(9) *Local test circuit (marking)*. This circuit is a polar circuit incorporated in the permanent wiring of the table and therefore cannot be changed. If the bias winding of relay R is connected so that the relay can receive neutral signals from the receive line, the bias circuit will be opened at the LOCAL TEST key when it is in TEST position. The transmitter distributor sends a mark to the R relay with the LOCAL TEST key in TEST position as follows: Negative battery is applied through resistor AG, through made contacts of LOCAL TEST key in TEST position, through 3 and 2 of the transmitter distributor, through made contacts of TIMING TEST key in REG position, through made contacts of LOCAL TEST key in TEST position, through 6-3 winding of relay R, through made contacts of LOCAL TEST key in TEST position, to terminal 6 of B block, and through half of voltage divider A to positive battery.

(10) *Local test circuit (spacing)*. Positive battery is applied through resistor F, through made contacts of LOCAL TEST key in TEST position, to terminal 7 of B block, through 1 and 2 of transmitter distributor and then through the same path as for marking except that it passes through the other half of voltage divider A, to negative battery.

(11) *Synchronizer circuit, normal condition of circuit before operation*. Capacitors E, F, G, and H are charged. Although these capacitors are shown as one variable capacitor in figure 250, they are actually four capacitors. Different combinations of these capacitors may be connected to the circuit by the

strapping arrangement of the C block as shown in table I. The charging path for the capacitors is as follows: Negative battery through resistor AK to one side of capacitors and positive battery through resistor L and resistor BY to other side of capacitors. The charged capacitors cause the grid of the vacuum tube to become positive enough, with respect to the filament, to cause the tube to conduct current. The tube current flows through windings 6-1 and 5-2 of relay P causing it to operate to its No. 3 contact. Relay N is operated by the following path: Negative battery is applied through resistor AK, through winding of N relay, through 7 and 3 of relay P, through made contacts of TIMING TEST key in REG position, and through resistor F to positive battery. The SYNC key is in REG position. Therefore, its contacts are open as shown in figure 250. Relay R is operated to its No. 4 contact as it is receiving a steady mark over the receive line. Therefore, the typing reperforator is marking. Relays MK and L are operated to their No. 5 contacts and relays SP and TR are operated to their No. 4 contacts by the following path: Positive battery is applied through resistor E, through 2-7 winding of relay TR, through 2-7 winding of relay SP, through 7-2 winding of relay L, through 7-2 winding of relay MK, and through resistor AF to negative battery. Relay TS is operated to its No. 3 contact by the following path: Positive battery through resistor N, through 1-6 winding of relay TS, through 4 and 1 of relay TR, through resistor AC to negative battery. Winding 1-6 is stronger than winding 2-5. Capacitor C is discharged by the following path: negative battery through resistor AJ to one side of capacitor, negative battery is also connected through resistor AC, and 1 and 4, of relay TR to the other side of capacitor. Relays FS and SL are operated to their No. 3 contacts by the following path: Positive battery is applied through resistor N, through 1-6 winding of relay SL, through 1-6 winding of relay FS, through 5 and 1 of relay MK, and through resistor AB to negative battery. The 1-6 windings of relays FS and SL are stronger than the 2-5 windings. Capacitors A and B are discharged through the following path: Negative battery through resistor AH to one side of capacitors, and negative battery through resistor AB, through 1 and 5 of relay MK to the other side of the capacitors. Clutch lever contacts are open, as these contacts are on the typing reperforator and are closed by the operation of the main shaft clutch throw-out lever under control of the 6th cam.

(12) *Synchronizer circuit, automatic cut in feature.* Relay R receives a space from the receive line, partly discharging capacitors E, F, G, and H. The discharge path is as follows: Negative battery through resistor AA, through 1 and 5 of relay R, through resistor BZ, to one side of capacitors. Negative battery is already applied to the other side of the capacitors. After several spacing pulses have been received on relay R, the capacitors will have discharged to the point where the grid potential of the tube is negative enough to cut off the operation of the tube. Relay P will now release to its number 4 contact. There is a biasing spring on the relay that causes the release. Relay N releases as its operating path is broken at No. 3 of relay P. The synchronizer circuit is now in operation.

(13) *Synchronizer circuit, sequence of operation.* The clutch lever contacts on the typing reperforator are closed, by the action of the selector cam sleeve. Relays MK and L operate to their No. 4 contacts by the following path: Positive battery is applied through resistor B, through made clutch lever contacts, through 3-6 winding of relay L, through 3-6 winding of relay MK, and through resistor AD to negative battery. The 3-6 windings are stronger than the 2-7 windings. To insure the fact that relay MK stays operated to its No. 4 contact after the clutch lever contacts open again, the following lock-up circuit is provided: Negative battery is applied through resistor AD, through 6-3 winding of relay MK, through 6-3 winding of relay L, through 4 and 1 of relay L, through 7 and 3 of relay TS and through resistor B to positive battery. The artificial stop pulse now begins. The circuit is from negative battery through resistor AB, through 1 and 4 of relay MK, through 7 and 3 of relay FS, through 4 and 3 of relay N, through 4 and 1 of relay SP, through tip of jack and plug, through selector magnet, through sleeve of plug and jack to terminal 12 of C block, through strap to terminal 11 of C block, through resistor BF, and through resistors BF, BG, and G to positive battery. The beginning of this artificial stop pulse comes just after a normal stop pulse is received on the R relay. If the R relay is receiving the normal pulse at this time, it will close through a path from negative battery in parallel with the artificial stop path. This will not interfere with operation. If faulty radio reception causes the R relay to be spacing at this time, the artificial stop pulse controls the selector magnet and operates it to mark. Capacitors A and B begin charging as the discharge path was removed when relay MK oper-

ated to its No. 4 contact. The capacitors charge as follows: Positive battery is applied through resistor N, through 1-6 winding of relay SL, through 1-6 winding of relay FS, to one side of the capacitors, and negative battery through resistor AH to the other side of the capacitors. The charging current for the capacitors therefore has to flow through the 1-6 windings of the SL and FS relays. As the capacitors charge, the current in the 1-6 windings is being reduced. When the value of current in the 1-6 winding of relay FS is slightly less than that in the 2-5 winding, the relay will operate to its No. 4 contact, thereby opening the circuit for the artificial stop pulse. The artificial stop is terminated in this manner approximately 6 milliseconds before the end of a normal stop pulse. This depends on the adjustment of the FAST potentiometer which determines the value of current in the 2-5 winding. The FAST potentiometer was adjusted during the local tests and adjustments of the set as outlined in c above. Relay SL operates to its No. 4 contact shortly after relay FS. This is because the SLOW potentiometer has been adjusted to allow a power current value in the 2-5 winding of relay SL than in the 2-5 winding of relay FS. The current in the 1-6 winding of relay SL is, of course, of the same value as that in the 1-6 winding of relay FS at any instant. Relays TR and SP operate to their No. 5 contacts by the following path: Positive battery through resistor C, through the 6-3 windings of relays TR and SP, through 4 and 7 of relay SL, through 4 and 1 of relay MK, through resistor AB, to negative battery. The 6-3 windings have sufficient current in them to gain control over the 2-7 windings. Relay SP opens the selector magnet circuit (the former shorting path around 1 and 4 of relay SP is open now as relay N is released). This begins the artificial start pulse. If relay R is receiving a normal start pulse at this time, it opens the selector magnet circuit in another place. If, because of faulty reception, the R relay is on its marking contact, relay SP sends a start pulse to the selector magnet. Capacitor C starts to charge as its discharge path is opened by the operation of relay TR to its No. 5 contact. The charging path for capacitor C is from positive battery through resistor N, through the 1-6 winding of relay TS, to one side of capacitor, and negative battery through resistor AJ to the other side of capacitor. As capacitor C is charged, the current in the 1-6 winding of relay TS decreases until the 2-5 winding gains control of the relay and operates to its No. 4 contact. The locking circuit for relays MK

and L is now broken at No. 3 contact of relay TS. Relays MK and L therefore operate to their No. 5 contacts under control of their 2-7 windings. Capacitors A and B are again discharged as the discharge path is closed through 5 and 1 of relay MK. Relays FS and SL are reoperated to their No. 3 contacts, as the circuit through the 1-6 windings of the relays is again closed through 5 and 1 of relay MK. Relays SP and TR reoperate to their No. 4 contacts as their 6-3 winding circuit is now open at No. 4 of relay SL, and 2-7 windings have control. When relay SP reoperates to its No. 4 contact, the selector magnet circuit is closed, thereby terminating the artificial start pulse. Capacitor C is discharged as the discharge path is again closed through 4 and 1 of relay TR. The synchronizer circuit is now completely restored to its original condition, and another closure of the clutch lever contacts will begin the operation over again.

(14) *Synchronizer circuit, time out feature.* Relay R operates to its marking contact after the end of a message. Capacitors E, F, G, and H charge again as described in (11) above. The grid of the tube is made more positive until the tube conducts current and reoperates relay P to its No. 3 contact. Relay N now reoperates, making the synchronizer circuit ineffective.

Section II. TELETYPEWRITER SET AN/TGC-1

142. General Introduction

Teletypewriter Set AN/TGC-1 is comprised of a metal console which houses the following: two receiving-only typing reperforators, a multiple transmitter distributor comprised of a number transmitter and two message transmitters, a motor-driven tape winder, a rectifier, a number tape reel, and circuit and control elements. These elements are arranged to operate on one circuit with both message transmitters arranged to permit continuous transmission without loss of line time and message numbers automatically inserted by the number transmitter. In this case the upper typing reperforator provides a continuous monitor copy of the outgoing message, while the lower typing reperforator receives the incoming messages. The set may also be arranged to operate on two circuits. In this case the No. 1 circuit uses the A (middle) transmitter for sending and the lower typing reperforator for receiving. The No. 2 circuit uses the B (right-hand) transmitter for sending and the upper typing reperforator for receiving. The number transmitter

functions with the No. 1 circuit only. When the set is arranged to work on one circuit, only, operation is designated NORMAL. When the set is arranged to work on two circuits, operation is designated SPLIT. The typing reperforators and transmitter distributor used by Teletypewriter Set AN/TGC-1 are similar to the typing reperforator and transmitter distributor covered in paragraphs 37 through 65. The necessity for outlining their mechanical operations and adjustments is thereby eliminated. Teletypewriter Set AN/TGC-1 is shown in figure 252.

143. Description

At the bottom of Teletypewriter Set AN/TGC-1 an equipment drawer is mounted. This drawer contains the transmitting and receiving relays, control relays, resistors and spark killers, together with the necessary switches for adapting the set to different types of operation. The SPLIT-NORMAL switch, SA, makes all the necessary changes from one-circuit to two-circuit operation. The DUPLEX-SINGLE switch, SB, makes all the necessary changes from duplex to single (half-duplex) operation. The POLAR MAKE-AND-BREAK switches, S3 and S4, are for adapting the set to polar or neutral operation. The OP-NON-OP switches, S1 and S2, prevent interference with the operation of alarm or break features. When the set is operating SPLIT, if one of the two circuits should be disconnected, switch S1 or switch S2 is switched to its NON-OP position. Switch S1 is for circuit No. 1 and switch S2 is for circuit No. 2. The line terminal strip is mounted at the left of the equipment drawer. The terminal strip is in two sections, each section consisting of nine terminals. The first eight terminals in each case are used for line and line battery connections. The ninth terminal on the left section is bonded to the console, so that the entire console may be connected to ground. The ninth terminal on the right section provides ground for an alarm bell common to all sets if this feature is desired. The power cabinet is located at the right of the equipment drawer and contains a male plug base for the power input, a main power switch, fuses for all circuits, an AC-DC switch for adapting the set to a-c or d-c primary power supplies, series resistors for the motors for d-c operation, and switches for shortening out these resistors for a-c operation. Just above the equipment drawer is a compartment for set tapes. The compartment may be divided by a partition which is provided to separate the tapes belonging to the two circuits for split operation.

There is a separate narrow compartment for the number tape. The number tape reel is mounted in front of the tape compartment just below the number transmitter. The reel holds the number tape to be used by the number transmitter in the transmission of message numbers. The reel can hold a prepared number tape of about 750 numbers. Above the tape compartment is the multiple transmitter distributor mounted on roller slides so that it may be pulled out for inspection. The receiving typing reperforator is mounted in a closed compartment above the transmitter distributor. The typing reperforator is on roller slides so that it may be pulled forward. The rectifier unit is mounted behind the typing reperforator. Four monitor jacks, two for the

transmitting and two for the receiving circuits, are mounted in the same compartment. Another closed-in compartment, which houses the monitor typing reperforator and the motor-driven tape winder; is just above the receiving typing reperforator compartment. Both the monitor typing reperforator and the tape winder are on roller slides. The tape winder consists of an ac-dc series motor, reduction gear, clutch, 10-inch reel, and illuminating lamp. The monitor copy tape from the monitor typing reperforator is wound on this tape winder. At the top of the console is the signal indicator: The signal indicator is comprised of alarm lamps, release, break, and feed-out keys and an alarm switch, housed in a demountable box which is connected to the con-

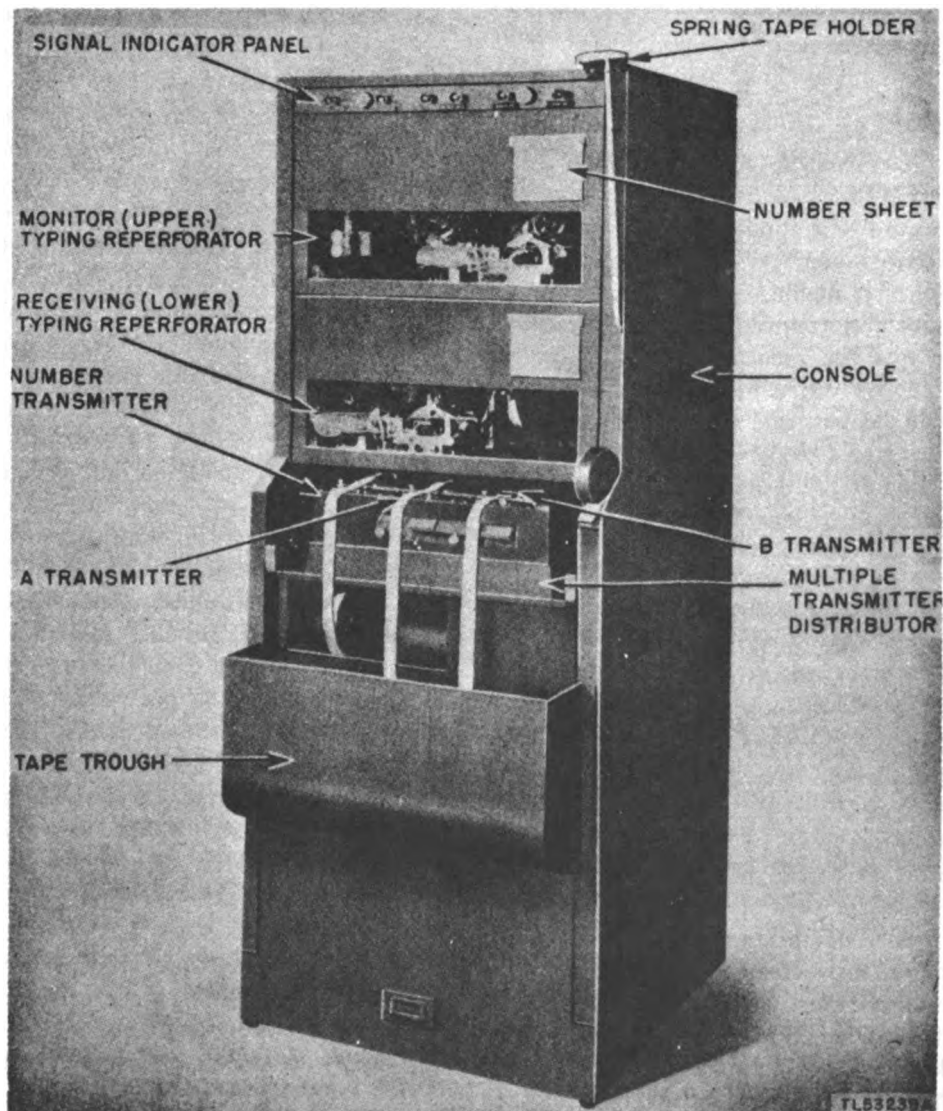

Figure 252. Teletypewriter Set AN/TGC-1 (view 1).

sole by means of a plug and socket. The NUMBER RELEASE key disables the automatic numbering feature. The two FEED-OUT keys, FO-1 and FO-2, are for the purpose of feeding tape out of the two typing reperforators when no messages are being received. The BREAK key is for the purpose of sending a break signal to the distant station. The BREAK lamp is a red lamp and lights when a break signal is received from the distant station. The lighting of this lamp indicates that the transmitters have been locked out and must be released for transmission. The RELEASE key releases the transmitters. The console is designed so that all power and signal line connections are accessible from the front, and the consoles may be set up side by side, back to back, or against the wall. Figures 253 and 254 show the various component parts of Teletypewriter Set AN/TGC-1.

144. Installation

a. GENERAL. The console should be placed in a well-lighted location that is convenient for operation. All signal, power, and ground wires should be run in a neat and secure manner, with no loose, dangling, or surplus wire that might be a safety hazard to personnel. In making connections to terminals be careful to see that the insulation is well cleaned from the wire and that the wire has not been nicked. The wire should be wrapped around the terminal screws in a clockwise direction with no excess bare wire on either side of the terminal screws. It is important that the terminal screws be tight. Insulated, twisted pair, inside wire of approximately 22 gage, such as used for telephone substation work, is suitable for signal line connections. The equipment ground wire should not be less than 14 gage and should be properly connected to a cold-water pipe or some other approved ground. The equipment drawer should be set in front of the console, and the 27-pin plug, the 30-pin plug, and the power plug should be plugged into their respective sockets. The equipment drawer can now be raised onto its slides and pushed back into position. The number tape reel is fastened in position below the transmitter shelf by means of the screws provided. The sliding transmitter shelf should be pulled out and the transmitter distributor unit placed on it. The 8-pin plug and the power plug are plugged into their respective sockets, and the sliding shelf pushed back. The tab number holder fastens on the right of the console by means of the screws provided. The rectifier unit is placed in the cradle behind the sliding

shelf for the lower typing reperforator, and the input and output plugs of the rectifier are plugged into their respective sockets. The lower typing reperforator can now be placed on the sliding shelf. The tape chute should be positioned so that it will deflect the tape to the front. The motor and signal plugs of the typing reperforator plug into the power socket and signal jack respectively. The upper typing reperforator should now be placed on the upper sliding shelf, and the motor and signal plugs connected to their respective sockets. The tape chute in this case should be positioned so that it will allow the tape to pass straight through. The tape winder is fastened to the shelf by means of the bolts provided. The 27-pin plug attached to the signal indicator plugs into the socket at the top of the console. The signal indicator is fastened to the console by means of the screws provided. The spring tape holder fastens to the upper right-hand corner of the console by means of the screws provided.

b. POWER AND GROUND CONNECTIONS. The power supply for Teletypewriter Set AN/TGC-1 can be 110-120 volts and either alternating current or direct current. The frequencies that may be used for an a-c supply are 50-60 cycles. Both AC-DC switches in the power cabinet must be thrown to the correct position depending on whether the supply is alternating current or direct current. If the source is alternating current, the reperforator and transmitter distributor motors must have the 10- and 300-ohm governor resistors shorted out. When the source is direct current, the resistors must not be shorted out. The flexible lead on the rectifier unit should be connected to the primary tap of the input transformer which corresponds most nearly to the voltage of the power supply. Be sure that the grounded side of the power supply is connected to the ground side of the set (the wide pin in the plug base in the power cabinet). Terminal blocks LRS1 and LRS2, which are in the equipment drawer, must be cross-connected according to the type of power supply to be used. Figure 255 shows the various cross-connecting arrangements. If the supply is direct current and the live side is positive, strap block LRS1 straight across to block LRS2 as shown by the solid lines in figure 255. If, however, the live side is negative, the blocks are cross-connected *crossed* as shown by the dotted lines in figure 255. When the supply is alternating current and the rectifier is used, the blocks are cross-connected in the same manner as they were for direct current with the live side positive. A short length of flexible cord is

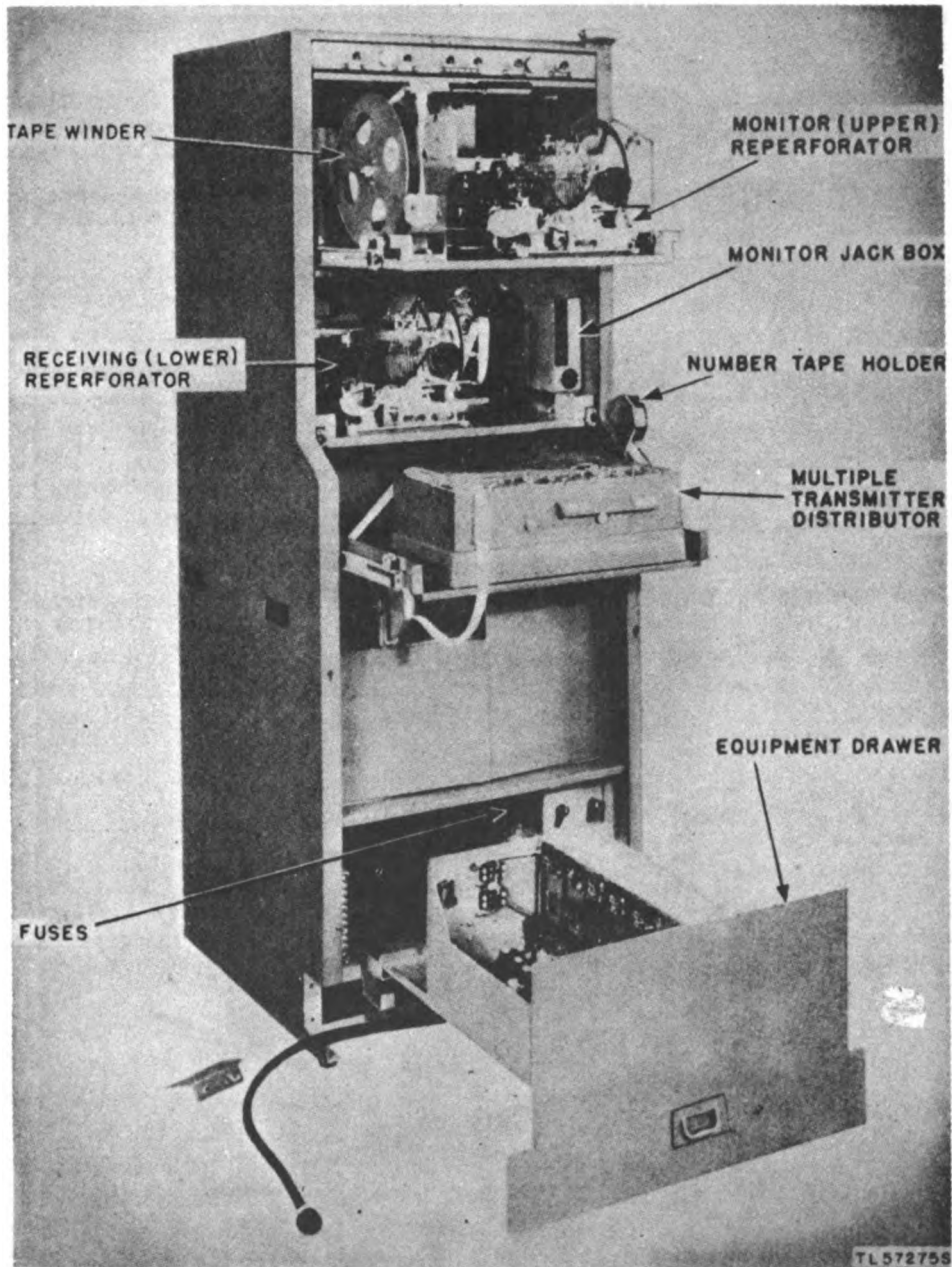

Figure 253. Teletypewriter Set AN/TGC-1 (view 2).

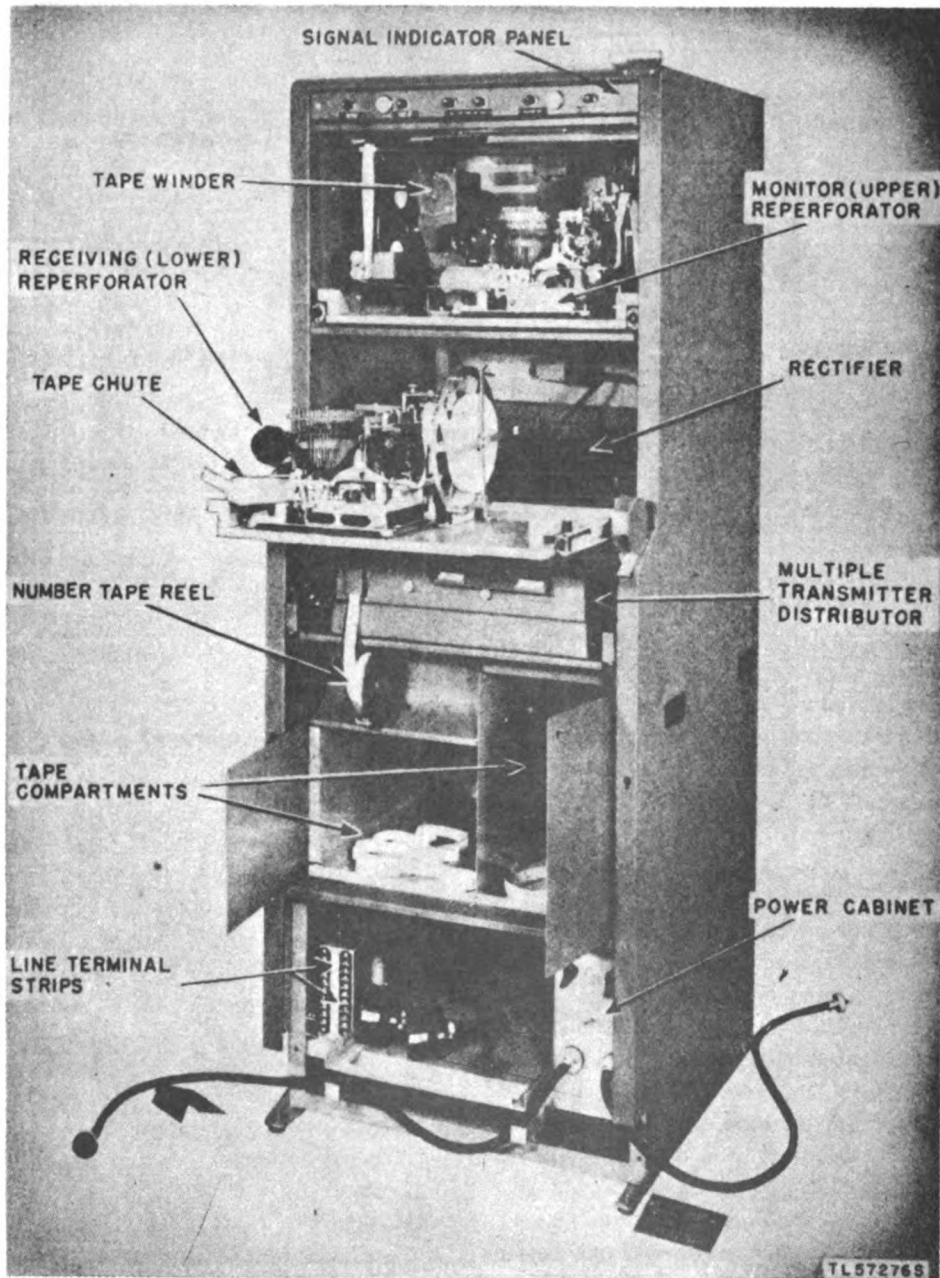

Figure 254. Teletypewriter Set AN/TGC-1 (view 3).

provided with each Teletypewriter Set AN/TGC-1. This cord is equipped with a plug on one end and a socket on the other end. The socket end plugs into the flush male base at the lower right-hand corner of the power cabinet. The plug end of the cord plugs into the room outlet for the power supply. With the power connected to the set and the main power switch in the power cabinet switched to ON, the transmitter distributor and the reperforator motors should run. When several sets are being set up side by side, they may be connected to power by means of the short cords provided. The cord provided with the second unit may be plugged into the flush male base of the second set and into the spare socket of the first set, and so on. By this means power may readily be connected to several sets. Since each set may draw up to 5 amperes, not more than three sets may be so connected. The equipment ground wire connects to terminal 9 of the left section of the line terminal strip.

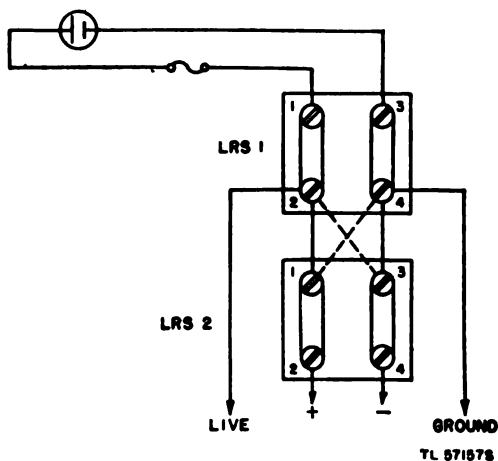

Figure 255. Cross connection diagram for terminal blocks LRS1 and LRS2.

c. LOCAL TEST. It is necessary to prepare a number tape. A master copy for the number tape is made up manually in one single long tape. The capacity of the tape will depend on the traffic need of the individual circuit, but 500 numbers will be ample for a day's work on even a heavy circuit. The form of the tape is as follows: Carriage return, line feed, office call, channel letter, figures, serial number, space, letters, blank, blank, blank, blank. This form is repeated for each consecutive number. It is important that there shall be no errors in the number tape. If errors are erased by means of the letters key, the erasures will be incorrectly interpreted by the number transmitter as indicating the termination of a number. Once the master tape is

completed, multiple copies can be made for use on the set. One of these copies is reeled up backward on the number tape holder and the front end (number 1) inserted in the number transmitter. To make a local test it is necessary to strap terminals 15 to 16 and 7 to 17 on the line terminal strip. A resistance of about 1,000 ohms must be inserted between terminals 7 and 17 to govern the line current. With switch SA thrown to NORMAL, switch SB to DUPLEX, switches S1 and S2 to OP, and switches S3 and S4 to POLAR, the line terminal strip should be connected for NORMAL-DUPLEX-POLAR according to figure 256. Messages transmitted on the A (middle) and B (right-hand) transmitters will be received on both the monitor and receiving typing reperforators, with numbers interpolated by the number transmitter. With the set operating in this manner, provided the motor speeds are correct, the ranges of the typing reperforators can be measured and the range finders set.

d. LINE CONNECTIONS. Line connections for various types of operation are made according to figure 256. The terminal strip is in two sections, each of nine terminals. The left-hand section consists of terminals 1 to 9 and the right-hand section consists of terminals 10 to 18. In figure 256 the two sections are shown one above the other for convenience.

145. Circuit Operation

a. GENERAL. The various circuits can best be traced by referring to figures 257 through 262. In these figures all relays are shown in their normal condition, whether operated or not operated. Switch SA is shown in the NORMAL position. Switch SB is shown in the DUPLEX position. The letter-L in the figures indicates the live side of the grounded battery and will be referred to as battery in tracing the circuits.

b. OPERATION OF RELAY RA OR RB. Relays RA and RB are for controlling operations of the transmitters. When a tape is placed in transmitter A and the transmitter start lever is depressed, there is a path from battery, through the 4-3 side of resistor R14, through contacts 5 and 6 of relay RNN, through contacts 24 and 23 of relay RB, through contacts 1 and 3 of switch SA3 in normal position, through the two windings of relay RA, through R23, through contacts 7 and 8 of relay RBK2, through the magnet of transmitter A, through the tape-out contacts, through the start lever contacts to ground. The current flowing in this circuit is sufficient to operate relay RA but is not great enough to oper-

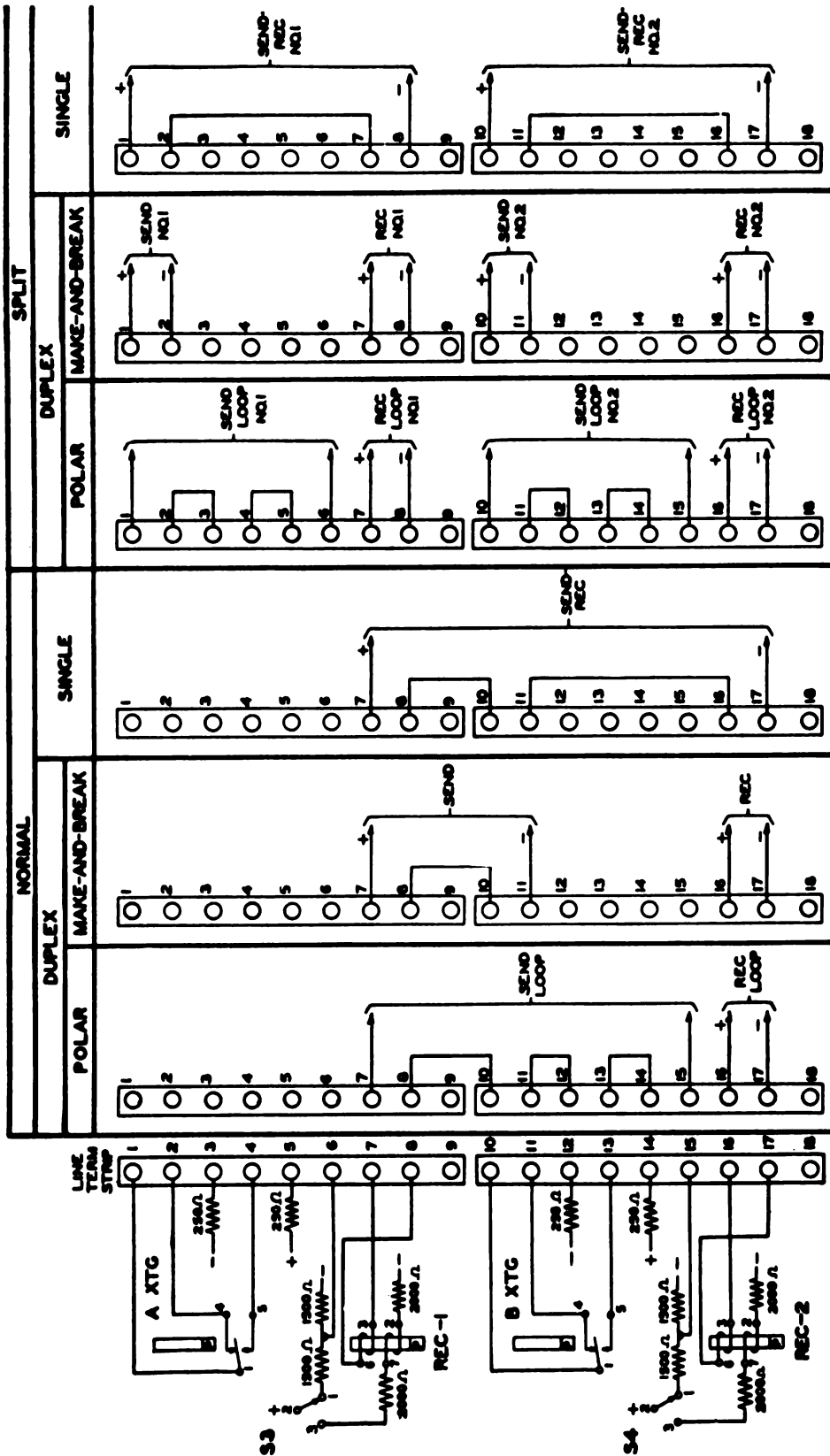

NOTE: BASED ON WESTERN UNION TELEGRAPH CO. DRAWING B-10219

Figure 256. Terminal strip connections for Teletypewriter Set AN/TGC-1.

TL57266S

ate the A transmitter magnet. A similar circuit may be traced for relay RB. The operation of relay RA, however, opens the operating path for relay RB at contacts 23 and 24 of relay RA. Therefore, if a second tape is inserted in transmitter B, no action can take place until after the release of relay RA. With switch SA thrown to its SPLIT position, there is a path from battery through the 4-3 section of resistor R14, through contacts 2 and 3 of switch SA3, through the windings of relay RA, and then to ground through the same path as described above. There is also a path from battery through the 2-3 section of resistor R11, through contacts 21 and 22 of relay RR2, through contacts 5 and 6 of switch SA3, through the windings of relay RB to ground through the path previously described. Relays RA and RB can now operate independently for SPLIT operation. With switch SB thrown to its SINGLE position, the short is removed from contacts 21 and 22 of relay RR2. Thus, if switches SA and SB are in the SPLIT and SINGLE positions respectively, relay RB cannot be energized while relay RR2 remains operated.

c. OPERATION OF NUMBER TRANSMITTER. The operating path for the number transmitter magnet is from battery through the 2-3 side of resistor R11, through contacts 21 and 22 of relay RR2 or contacts 3 and 1 of switch SB, through resistor R24, through contacts 7 and 9 of switch SA5 in the NORMAL position, through contacts 2 and 1 of relay RN, through the closed contacts of the NUMBER RELEASE key, through the magnet of the number transmitter, through the tape-out contacts, through the start lever contacts to ground. The winding of relay RN is connected in parallel with the number transmitter magnet, but the resistances of the two branches of the circuit are so proportioned that sufficient current flows to operate the magnet but not relay RN. The operation of the magnet causes the transmitter to send out the next number. At the end of the number a letters character is sent which causes the letters operating lever on the transmitter to open momentarily the tape-out contacts. This opens the magnet circuit and stops the transmitter. The opening of the magnet circuit also causes the current in the parallel RN relay branch to rise high enough to operate relay RN. Relay RN operates and therefore opens contacts 1 and 2 preventing reoperation of the transmitter magnet even though the tape-out contacts close again. When switch SA is thrown to the SPLIT position, contacts 6 and 7 of relay RB are removed

from the number transmitter magnet circuit, so that the number transmitter does not function under control of B transmitter. When switch SB is thrown to SINGLE, it removes the short from across contacts 21 and 22 of relay RR2. Thus if switches SA and SB are in NORMAL and SINGLE positions, respectively, the number transmitter cannot be operated while relay RR2 remains operated.

d. OPERATION OF NUMBER RELEASE KEY. As described previously, when battery is applied to relay RN and the number transmitter magnet in parallel, the magnet is operated; but as soon as the magnet circuit is broken, relay RN operates. Depressing the NUMBER RELEASE key opens the number transmitter magnet circuit. If, therefore, the NUMBER RELEASE key is depressed when a tape is in the A or B transmitter, and is held depressed until after the transmitter start lever contacts are closed, relay RN will operate after relay RA or RB operates and no number will be transmitted.

e. OPERATION OF A OR B TRANSMITTER With relay RN released, there is a path from battery through the 2-1 side resistor R16, through contacts 4 and 3 of relay RN, through the winding of relay RNN to ground, thereby operating relay RNN. Therefore after a number has been transmitted by the number transmitter and relay RN operates, relay RNN is released. If a tape is in transmitter A and relay RA has been operated, the contacts 1 and 2 of relay RNN shorts out the high-resistance winding of relay RA together with the 2,000-ohm series resistor R23. This raises the current in the circuit to a value sufficient to operate the A transmitter magnet and at the same time the high value of current through the low resistance winding of relay RA holds the relay operated. The operation of the A transmitter magnet causes the A transmitter to send out the message. A similar circuit may be traced for the B transmitter magnet. In this case the high resistance winding of relay RB is shorted out by contacts 3 and 4 of relay RNN. At the end of the message, as the tape runs out, the tape-out contacts open causing the release of both the transmitter magnet and the relay RA (or RB). The release of the relay opens the operating circuit of relay RN. The released RN relay completes a path through its contacts 3 and 4 to reoperate relay RNN. This restores the set to normal in readiness for the transmission of a second message. If a tape has already been placed in the idle transmitter, the reoperation of relay RNN will immediately complete

a path to operate the associated RA (or RB) relay, thereby starting a new cycle of operation. When switch SA is thrown to the SPLIT position, contacts 3 and 4 of relay RNN are no longer in the shorting path for the high-resistance winding of relay RB. Therefore, relay RB is no longer associated with relay RN. Relay RB can now operate independently as described in *b* above. Therefore the number 2 circuit using transmitter B will have no automatic message numbering with SPLIT operation.

f. OPERATION OF A AND B TRANSMITTING RELAYS. With switch SA thrown to the NORMAL position, the line winding of the B transmitting relay is connected in series with the transmitting contacts of both message transmitters and the number transmitter. The path is from negative battery through the 2-1 half of resistor R6, through the transmitting contacts of the number transmitter through the transmitting contacts of the A transmitter, through the monitor jack MJ-3, through contacts 3 and 1 and 4 and 6 of switch SA1, through the transmitting contacts of the message transmitter B, through the monitor jack MJ-4, through the made contacts of the BREAK key, through the 6-3 winding of the B transmitting relay, through the 6-5 section of resistor R19 to positive battery. The bias circuit for the B transmitting relay is from positive battery through the 2-3 section of resistor R19, through the 7-2 winding of the B transmitting relay, through the 3-2 section of resistor R5 to negative battery. The B transmitting relay therefore follows the neutral signals of any one of the three transmitters. A spare transmitter or keyboard plugged into monitor jack MJ-3 or MJ-4 can also operate the B transmitting relay. When the switch SA is thrown to the SPLIT position, the B transmitting relay is under control of the B transmitter alone, and the A transmitting relay is under control of the A and the number transmitters. The circuit for operating the B transmitting relay is from positive battery through the 5-6 section of resistor R19, through the 3-6 winding of the B transmitting relay, through the made contacts of the BREAK key, through the monitor jack MJ-4, through the transmitting contacts of the B transmitter, through contacts 6 and 5 of switch SA1, through the 3-2 section of resistor R6 to negative battery. The operating circuit for the A transmitting relay is from positive battery through the 5-4 section of resistor R19, through the 3-6 winding of the A transmitting relay, through contacts 2 and

3 of switch SA1, through the monitor jack MJ-3, through the transmitting contacts of the A transmitter, through the transmitting contacts of the number transmitter, through the 1-2 section of resistor R6 to negative battery.

g. POLAR SEND CIRCUIT. If NORMAL, POLAR operation is desired, throw switch SA to its NORMAL position and switch S4 to the POLAR position. Polar signals are now sent out on one send circuit from the contacts of the B transmitting relay. When the B transmitting relay is operated to its marking position by one of the transmitters, it sends a marking signal on a polar basis out on the send loop. The path is from negative battery through the 1-2 section of resistor R4, to terminal 12 of line terminal strip, through the strap to terminal 11 of line terminal strip, through contacts 4 and 1 of the B transmitting relay, to terminal 10 of the line terminal strip, through the strap to terminal 8 of the line terminal strip, through the 6-3 winding of the monitor receiving relay REC-1, to terminal 7 of the line terminal strip, through one side of the send loop, back through the other side of the send loop, to terminal 15 of the line terminal strip, through the 2-3 half of resistor R2 to positive battery. When the B transmitting relay is spacing, a spacing signal is sent on the send loop on a polar basis. The path is the same as it was for marking except that the armature of the B transmitting relay picks up positive battery from the No. 5 contact and the path is completed through the 2-1 half of resistor R2 to negative battery. If SPLIT, POLAR operation is desired, switch SA is thrown to its SPLIT position and switches S3 and S4 are thrown to their POLAR positions. The B transmitting relay now sends polar signals over send loop No. 2, which is connected to terminals 10 and 15 of the line terminal strip. The path is similar to that described above for the B transmitting relay, and, therefore, it is not necessary to trace it again. The A transmitting relay sends polar signals in a similar manner on send loop No. 1, which is connected to terminals 1 and 6 of the line terminal strip. It should be noted that the monitoring receiving relay REC-1 is no longer connected in series with a send loop as it was for NORMAL operation.

h. NEUTRAL SEND CIRCUITS. The send loops for this type of operation must have battery connected externally and the proper resistance connected in series to adjust the line current to 60 ma. For NORMAL, NEUTRAL operation, switch SA is thrown to its NORMAL position, and switch S3 is thrown

to its MAKE AND BREAK position. The B transmitting relay sends neutral (make and break) signals on one send loop. The path is from positive externally supplied battery over one side of the send loop to terminal 7 of the line terminal strip, through the 3-6 winding of the monitor receiving relay REC-1, to terminal 8 of the line terminal strip, through the strap to terminal 10 of the line terminal strip, through contacts 1 and 4 of the B transmitting relay, to terminal 11 of the line terminal strip, over the other side of the send loop to negative battery. The bias circuit for the monitoring receiving relay REC-1 is from positive battery through contacts 2 and 3 of switch S3, through the 1-2 section of resistor R22, through the 7-2 winding of relay REC-1, through the 4-5 section of resistor R5 to negative battery. When operation is SPLIT, the A transmitting relay sends neutral signals on send loop No. 1 which is connected to terminals 1 and 2 of the line terminal strip. The B transmitting relay sends neutral signals on send loop No. 2 which is connected to terminals 10 and 11 of the line terminal strip. Both of these send loops must have external battery and the proper resistance to adjust the line current at 60 ma.

i. OPERATION OF BREAK KEY. The BREAK key contacts are in series with the 3-6 winding of the B transmitting relay and therefore when operated will cause the B transmitting relay to operate to its spacing contact. This causes a spacing signal to be sent on the send loop for as long as the key is held operated. Since the BREAK key is not associated with the A transmitting relay, it is not possible to send a break signal on send loop No. 1 when the set is operating SPLIT.

j. POLAR RECEIVE CIRCUITS. There is only one receive loop connected to the set for NORMAL operation. The battery for supplying the polar receive loop is at the sending end. When marking signal is received, negative battery is applied over one side of the loop to terminal 17 of the line terminal strip, through the 6-3 winding of the receiving relay REC-2 to terminal 16 of the line terminal strip, over the other side of the receive loop to positive battery. When receiving a spacing signal, the polarities of battery applied to terminals 16 and 17 are reversed, thereby operating the receiving relay REC-2 to its spacing contact. The bias winding of the receiving relay is not energized because the bias circuit is open at the No. 3 contact of switch S4. The receiving (lower) typing reperforator selector magnet is operated under control of

the receiving relay REC-2. When the receiving relay is operated to its marking contact, there is a path from battery through the 2-1 section of resistor R9, through contacts 3 and 1 of switch SA2, through jack MJ-2, through the winding of the selector magnet which is connected by means of a cord and plug to jack PJ-2, through contacts 4 and 6 of switch SA2, through contacts 4 and 1 of relay REC-2, through contacts 1 and 2 of switch S2 to ground. When operation is SPLIT, an additional receive loop is connected to terminals 7 and 8 of the line terminal strip. The 3-6 winding of the monitor receiving relay REC-1 is connected to this receive loop and operates on the polar signals received from the loop. It will be noted that receiving relay REC-2, which still operates on signals received from the loop that is connected to terminals 16 and 17, now controls the upper typing reperforator selector magnet, and the lower typing reperforator is under control of the receiving relay REC-1. This is because switch SA is now in its SPLIT position.

k. NEUTRAL RECEIVE CIRCUITS. When the set is prepared for neutral (make and break) operation, switches S3 and S4 are thrown to their MAKE AND BREAK positions. With the switches in these positions the bias windings of the receiving relays REC-1 and REC-2 are energized and the relays, therefore, can receive neutral signals. For NORMAL operation there is one receive loop which is connected to terminals 16 and 17 of the line terminal strip. The 3-6 winding of the receiving relay REC-2 is connected across terminals 16 and 17 and operates on the received neutral signals as it has its bias winding energized. The selector magnet of the lower typing reperforator is operated under control of the receiving relay REC-2. An additional receive loop is connected to terminals 7 and 8 of the line terminal strip for SPLIT operation and operates the monitor receiving relay REC-1. As described in *j* above for SPLIT operation; relay REC-1 controls the selector magnet of the lower typing reperforator and relay REC-2 controls the selector magnet of the upper typing reperforator.

l. HALF-DUPLEX OPERATION. In all of the foregoing subparagraphs on circuit operation, it has been assumed that the set was operating on a full-duplex basis; that is, separate send and receive loops. It is possible to have the set operate on a half-duplex (single) basis using only one loop for both sending and receiving. This type of operation can be used with the set working either NORMAL or SPLIT. For half-duplex operation, however

only neutral signals can be used. When NORMAL, HALF-DUPLEX operation is desired, switch SA is thrown to its NORMAL position and switch SB is thrown to its SINGLE position. The send-receive loop must have battery supplied externally and the current adjusted to 60 ma. A path may be traced from positive battery over one side of the loop to terminal 7 of the line terminal strip, through the 3-6 winding of the monitor receiving relay REC-1 to terminal 8 of the line terminal strip, through the strap to terminal 10 of the line terminal strip, through 1 and 4 of the B transmitting relay to terminal 11 of the line terminal strip, through the strap to terminal 16 of the line terminal strip, through the 3-6 winding of the receiving relay REC-2 to terminal 17 of the line terminal strip, over the other side of the loop to negative battery. From this circuit it can be seen that when the B transmitting relay is sending, both of the receiving relays follow the signals. With the B transmitting relay in a steady marking condition, neutral signals which are sent by the distant end can be received on both receiving relays. If SPLIT, HALF-DUPLEX operation is desired, two send-receive loops are used, and switch SA is thrown to its SPLIT position. Send-receive loop No. 1 is connected to terminals 1 and 8 of the line terminal strip, and send-receive loop No. 2 is connected to terminals 10 and 17 of the line terminal strip. The path for circuit No. 1 is from positive battery over one side of the loop to terminal 1 of the line terminal strip, through 1 and 4 of the A transmitting relay to terminal 2 of the line terminal strip, through the strap to terminal 7 of the line terminal strip, through the 3-6 winding of the relay REC-1 to terminal 8 of the line terminal strip, over the other side of the loop to negative battery. When the A transmitting relay is sending, a monitor copy of the message is received from relay REC-1 and incoming messages are received on the same relay while the A transmitting relay is in a steady marking condition. A similar path can be traced for circuit No. 2 which uses the B transmitting relay and receiving relay REC-2.

m. OPERATION OF FEED-OUT KEY FO-1. If it is desired to cause the typing reperforator, which is under control of relay REC-1, to feed out tape while the relay is idle on its marking contact, key FO-1 is pressed. If the switch SA is in its NORMAL position, the upper monitor typing reperforator is under control of the relay REC-1. In this case pressing the key FO-1 closes a path from

ground through contacts 2 and 1 of relay RR1, through the made contacts of key FO-1, through contacts 9 and 7 of switch SA1 to one side of the upper typing reperforator selector magnet. Ground is also applied to the other side of the winding through contacts 2 and 1 of switch S1, contacts 1 and 4 of relay REC-1, and contacts 12 and 10 of switch SA1. With ground applied to both sides of the selector magnet winding, the winding is shorted out and therefore the magnet is released. This causes the typing reperforator to feed out blanks. If, while key FO-1 is held depressed, relay REC-1 operates to its spacing contact, there is a path completed to operate relay RR1. The path is from battery through the 2-1 section of resistor R15, through the made contacts of the key FO-1, through the winding of relay RR1, through contacts 5 and 4 of relay RR1, through contacts 5 and 1 of relay REC-1, through contacts 1 and 2 of switch S1 to ground. The operation of relay RR1 opens the path from ground at contact 1 of the relay, thereby placing the typing reperforator magnet back under control of relay REC-1. When relay RR1 operates, a locking path is provided through its own contacts to keep the relay operated when relay REC-1 is not on its spacing contact. The path is from battery through the 2-1 section of resistor R15, through the made contacts of key FO-1, through the winding of relay RR1, through contacts 5 and 3 of the relay to ground. The release of key FO-1 will restore the circuit to normal. When switch SA is in its SPLIT position, the lower typing reperforator magnet is under control of relay REC-1. The operation of the key FO-1 causes the conditions just described for the upper typing reperforator magnet to be applied to the lower typing reperforator magnet.

n. OPERATION OF FEED-OUT KEY FO-2. When switch SA is in its NORMAL position and switch SB is in its DUPLEX position, relay REC-2 is the receiving relay and controls the receiving (lower) typing reperforator. To cause the lower typing reperforator to feed out tape, key FO-2 is pressed. Ground is applied to one side of the lower typing reperforator magnet winding through contacts 24 and 23 of relay RR2, through the made contacts of key FO-2, and through contacts 3 and 1 of switch SA2. Ground is also applied to the other side of the magnet winding through contacts 4 and 1 of relay REC-2; the magnet winding, therefore, is shorted out and the magnet is released, causing the typing reperforator to feed out blanks. If relay

REC-2 operates to its spacing contact, there is a path from battery through the 2-3 section of resistor R15, through the made contacts of key FO-2, through contacts 7 and 9 of switch SB1, through the winding of relay RR2, through the made contacts 28 and 27 of the relay, through contacts 12 and 10 of switch SB1, through 5 and 1 of relay REC-2, through contacts 1 and 2 of switch S2 to ground. Relay RR2 is therefore operated, and the typing reperforator magnet is back under control of relay REC-2. There is a locking path provided for relay RR2 through its own contacts 28 and 26, through contacts 3 and 4 of the RELEASE key to ground. This path will keep the relay operated if relay REC-2 should operate to its marking contact. Release of the key FO-2 restores the circuit to normal. If, while switch SA is in its NORMAL position, switch SB is thrown to its SINGLE position, there is a permanent path from battery through the 2-3 section of resistor R15, through contacts 8 and 9 of switch SB1, through the winding of relay RR2, through the made contacts 28 and 27 of the relay, through contacts 12 and 11 of switch SB1, through contacts 2 and 1 of relay RB, through contacts 1 and 2 of relay RA, through contacts 5 and 1 of relay REC-2 to ground. Thus if relays RA and RB are not operated (transmitters idle) and regardless of whether key FO-2 is depressed or not, relay RR2 will be operated as soon as relay REC-2 operates to its spacing contact. That is, the first start pulse received will cause relay RR2 to operate, disabling the feed-out circuit. The locking path for relay RR2 is through the RELEASE key as it was before. The operation of relay RR2 causes the BREAK lamp to light and, as described in *b* and *c* above, blocks all transmitters. Relay RR2 remains locked, stopping all transmission and the lamp remains lighted until the RELEASE key is depressed and relay RR2 is released. It is not possible, therefore, when operation is NORMAL, HALF-DUPLEX (SINGLE) to operate any of the transmitters while a message is being received from the distant end. When switch SA is in its SPLIT position, the monitor typing reperforator is placed under control of relay REC-2 and becomes the receiving typing reperforator for circuit No. 2. Switch SA4 also shorts out contacts 2 and 1 of relay RA, so that the operation of relay RR2 (circuit No. 2) is independent of the operation of relay RA (circuit No. 1).

a. LOCKING OF TYPING REPERFORATORS. When switch SA is in its NORMAL position and switch

SB is in its SINGLE position, the signals on the send-receive loop, whether sent or received, will operate both relays REC-1 and REC-2 as described in paragraph 142. To prevent the received copy from being recorded on the monitor typing reperforator, the typing reperforator is held idle during reception. With the send-receive loop in an idle condition there is a path from battery through the 2-1 section of resistor R10, through contacts 9 and 7 of switch SA1 through jack MJ-1, through jack PJ-1 and the selector magnet of the monitor typing reperforator, through contacts 10 and 12 of switch SA1, through contacts 5 and 6 of switch SB1, through contacts 3 and 4 of relay RA, through contacts 10 and 12 of switch SA3, through contacts 3 and 4 of relay RB, through contacts 5 and 6 of relay RR2 to ground. This path holds the monitor typing reperforator in a steady marking condition. As soon as reception begins and relay REC-2 operates to its spacing contact, relay RR2 operates as described in *a* above. The holding path for the selector magnet is maintained, however, because the ground side of the path is now connected through contacts 6 and 4 of relay RR2, contacts 9 and 7 of switch SA1, and contacts 6 and 5 of switch SB1. Therefore, the monitor typing reperforator cannot follow relay REC-1 and record the received message. When transmission is in progress, relay RR2 is not operated and the holding path for the monitor typing reperforator selector magnet is broken at relay RA or relay RB, whichever is operated. Therefore the monitor typing reperforator is free to record the sent message. A similar circuit is provided to prevent the sent copy from being received on the receiving typing reperforator. The path is from battery through the 2-1 section of resistor R9, through contacts 3 and 1 of switch SA2, through jack MJ-2, through jack PJ-2, and the magnet of the receiving typing reperforator, through contacts 4 and 6 of switch SA2, through contacts 5 and 6 of switch SB2, through contacts 5 and 4 of relay RB (assuming relay RB as the relay operated), through contacts 5 and 6 of relay RR2 to ground. The circuit is broken upon the release of relay RB (or RA), leaving the receiving typing reperforator free to record the received copy. When switch SA is thrown to its SPLIT position, it interchanges the monitor and receiving typing reperforators as already shown. The holding path for the receiving typing reperforator magnet is broken at contact No. 7 of switch SA2 and also

at contact No. 10 of switch SA3. The receiving typing reperforator, therefore, records both the sent and received copy on circuit No. 1, under control of relay REC-1. Control of the monitor typing reperforator magnet holding circuit by relay RA (circuit No. 1) is disabled at contact No. 10 of switch SA3. This leaves relay RB controlling the holding circuit. Relay RB is associated with circuit No. 2; therefore, the monitor typing reperforator, acting as the receiving typing reperforator for circuit No. 2, records only the received copy.

p. **CALL-IN CIRCUIT.** Should the circuit be left unattended, the ALARM switch may be thrown on and the ALARM lamp will light and an alarm bell will ring if signals are received from the distant end. When switch SA is in its NORMAL position, the ALARM switch is operated and a spacing signal is being received on relay REC-2; relay RC will operate. The path is from battery through the 4-5 section of resistor R15, through the made contacts of the ALARM switch, through the winding of relay RC, through contacts 9 and 8 of relay RC through contacts 5 and 1 of relay REC-2, through contacts 1 and 2 of switch S2 to ground. Relay RC locks itself operated through contacts 9 and 7 to ground, so that it will remain operated after relay REC-2 leaves its spacing contact. The circuit to operate the ALARM lamp is closed through contacts 5, 4, and 3 of relay RC. The circuit to operate the bell is closed through contacts 2 and 1 of relay RC. To release relay RC, the ALARM switch must be thrown off. When switch SA is in its SPLIT position, the circuit just described which is under control of the spacing contact of relay REC-2 remains

the same, and the other winding of relay RC is connected to the spacing contact of relay REC-1. This makes the alarm feature responsive to received signals on either circuit No. 1 or No. 2. When relay RC is operated there is also a path from ground at terminal 9 of the line terminal strip closed through contacts 5 and 6 of relay RC, to terminal 18 of the line terminal strip. This path is for an external common alarm circuit if used.

q. **BREAK CIRCUIT.** Relay RBK1 is normally held operated by a path from battery through 2-3 section of resistor R9, through the winding of relay RBK1 to ground. Each time that relay REC-2 spaces, ground is applied to the No. 5 contact of the relay, thereby shorting out the winding of relay RBK1. Relay RBK1 is, however, a slow release relay and does not release on the normal operation of relay REC-2. If a sustained spacing impulse is received, as when the distant station sends a break, relay RBK1 will release. Relay RBK2, which is normally held operated through contacts 2 and 1 of relay RBK1, will release. The release of relay RBK2 closes through a path to light the BREAK lamp and also opens the magnet circuits of transmitters A and B, thereby stopping the A and B transmitter. When relay RBK2 has once been released, it breaks its own operating circuit at contact No. 4 and therefore cannot be reoperated by relay RBK1. Only the depression of the RELEASE key, which applies ground directly to the winding of relay RBK2, can reoperate relay RBK2. Since the break feature is not required in duplex operation, switch SB, when thrown to its DUPLEX position, applies ground to contact No. 4. This holds relay

Table 11. Switch positions for various types of operation.

Type of operation	Switch positions					
	Switch SA	Switch SB	Switch S3	Switch S4	Switch S1	Switch S2
Normal-duplex-polar	Normal	Duplex	Polar	Polar	OP	OP
Normal-half-neutral	Normal	Duplex	Make and break	Make and break	OP	OP
Normal-half-duplex	Normal	Single	Make and break	Make and break	OP	OP
Split-duplex-polar	Split	Duplex	Polar	Polar	OP	OP
Split-duplex-neutral	Split	Duplex	Make and break	Make and break	OP	OP
Split-half-duplex	Split	Single	Make and break	Make and break	OP	OP

RBK2 operated regardless of the release of relay RBK1. When switch SA is in its SPLIT position, it shorts out contacts 7 and 8 of relay RBK2; relay RBK2, therefore, when released opens the magnet circuit of the B transmitter only.

146. Preparation of Set for Operation

Figure 256 shows the proper line terminal strip connections for the various types of operation. Table II shows the proper positions of the switches for the various types of operation.

CHAPTER 5

RECORDS, PROCEDURE FOR ADVERSE CLIMATIC CONDITIONS, AND DESTRUCTION PROCEDURES

Section I. TACTICAL DIAGRAMS AND STATION RECORDS

147. General Introduction

Ordinarily, teletypewriter lines are installed by men, especially trained in that work. However, at times it may be necessary for the teletypewriter installer to install leads from the line terminals at his station to his equipment. This fact makes it essential that the installer of teletypewriter equipment be familiar with the symbols, designations, etc., that pertain to teletypewriter equipment and are found on tactical diagrams. A tactical circuit diagram gives, schematically, the technical arrangements and connections of line circuits and terminal installations of the wire system. It contains technical information necessary for wire personnel to install wire lines, teletypewriter equipment, telephone equipment, etc. A circuit diagram is very useful to the teletypewriter mechanic in the installation and trouble shooting of various teletypewriter sets in case of break-down in teletypewriter communication. When a subordinate unit installs its wire system, the fact is immediately reported to the next superior headquarters. Next, a supplement to the report, covering technical details of the installation, is forwarded through the message center. Interruptions and other changes in a wire net are reported immediately through the message center by the operating and maintenance personnel. Prompt reports enable the message center and higher headquarters to be informed at all times as to what channels are available. In order that they may tell at a glance what channels are open on specific equipment, traffic diagrams are made. It is well

for the teletypewriter mechanic to be familiar with these as well as with circuit diagrams. It may be necessary for him to prepare one for use at the station. The installer of teletypewriter equipment should keep an accurate record of the installation, servicing, and troubles encountered on all equipment for which he is responsible. These records serve as a check on operating and maintenance personnel and also furnish a record for the signal officer.

148. Basic Teletypewriter and Associated Symbols for Tactical Diagrams

The symbols covered in this section are used on circuit and traffic diagrams and are particularly useful to teletypewriter communications personnel. Frequently some of the symbols are combined with others. They are used to show the location of different teletypewriter and associated equipment and to indicate details of line construction. That is, the symbols show what kind of teletypewriter equipment is used at each station and what type circuits and associated equipments are used in electrically connecting the teletypewriter equipment. Complete familiarity with these symbols is a necessity for the teletypewriter mechanic to interpret the diagrams involved in field systems. The symbols were adopted because they are brief, use very little space, and, to those familiar with them, convey all the information necessary. The following tables give the abbreviations and symbols with their meanings for teletypewriter and associated equipment. Symbols and abbreviations necessary to show line construction are also given.

a. Teletypewriter Symbols.

Meaning

(1) Teletypewriter central. If a switching arrangement is not involved, the individual lines lead into the equipment to which it is connected. Normally the symbol is located inside the rectangle but may be found near or connected to the rectangle. In traffic diagrams, a large circle is used instead of a rectangle.....

(2) Teletypewriter page printer.....

(3) Teletypewriter tape printer.....

(4) Teletypewriter page printer (receive only)

(5) Teletypewriter tape printer (receive only)

(6) Teletypewriter reperforator and transmitter distributor. This symbol is drawn within the rectangle (or circle) which represents the central, to indicate the possibility of relaying the message by means of perforated tape.....

b. Associated Symbols

(1) D-C telegraph repeater (nonregenerative). The number of lines to each side or through the symbol will vary depending upon its type, use and method of operation. The type repeater may or may not be shown.....

(2) D-C telegraph repeater (regenerative). The number of lines to each side or through the symbol will vary depending on use and method of operation.

(3) Carrier repeater. The type carrier repeater may or may not be designated.....

(4) Carrier terminal. Here the type carrier is always designated. The symbol illustrates the superposition of three carrier channels onto one existing circuit. More or fewer channels may be designated. The E (East) and W (West) in the abbreviations designate the direction of transmission.....

Abbreviation

Symbol

Ttc

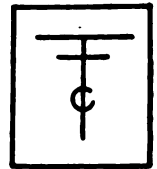

Tt



Tt



Tt



Tt



Rtr



T



REG.



CR



CE or CW

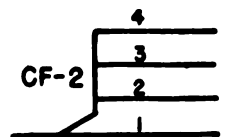

Meaning

(5) Repeating coil. This is used to show circuits that are simplexed or phantomed.....

(6) Single conductor with ground forming a return path.....

(7) Group of conductors branching out from cable. The number of pairs in the cable is normally designated

(8) One-way transmission. Arrow points in the direction of transmission.....

c. Sample Applications.

(1) Teletypewriter central equipped with switching arrangement. Two ground return and two full-metallic circuits are connected.....

(2) Teletypewriter central not equipped with switching arrangement. Two ground-return and two full-metallic circuits are connected. When the symbol for reperforator and transmitter distributor is not shown, message can be relayed by retyping only

(3) Two teletypewriter centrals connected by two nonregenerative repeaters working full duplex....

(4) Teletypewriter central connected to channels superposed by carrier equipment.....

(5) Teletypewriter central with phantom circuit connected

Abbreviation

Rpt C

Symbol

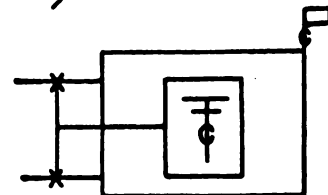
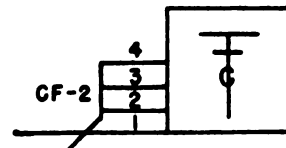
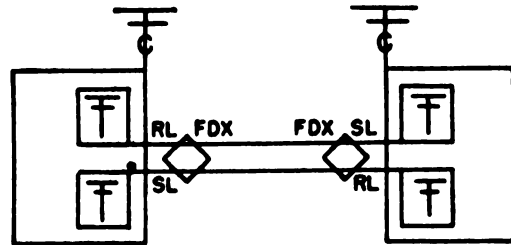
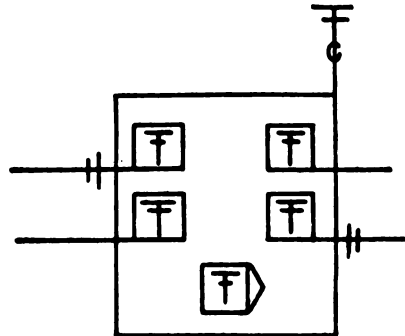
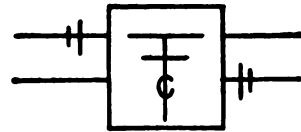
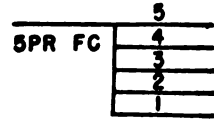
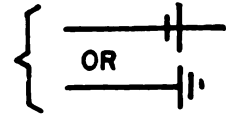

Meaning

Symbol

(6) Teletypewriter central with simplexed phantom circuit connected.....

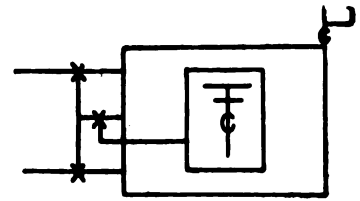

(7) Two teletypewriter centrals connected by three channels (as used in traffic diagrams).....

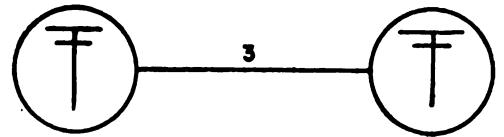

d. CIRCUIT DIAGRAM. The main purpose of a circuit diagram is to assist the wire chief in the maintenance of all line circuits. Circuit diagrams are useful to the teletypewriter maintenance man because they show the circuit numbers by which his equipment is connected. In tactical circuit diagrams each wire circuit shown is designated by a circuit number followed by a code name or number which indicates the installing unit. Each circuit diagram should show the date it becomes effective and should be signed by the signal officer. A simplified circuit

diagram is shown in figure 263. For the sake of simplicity, only the symbols for teletypewriter and associated equipment are shown (except for the telephone central at a command post). In actual practice all wire equipment symbols are shown on a tactical circuit diagram.

e. TRAFFIC DIAGRAM. A teletypewriter traffic diagram is a chart showing the number of channels that actually exists between the centrals in a teletypewriter system. Also shown are channels to individual machines. A single line indicates direct

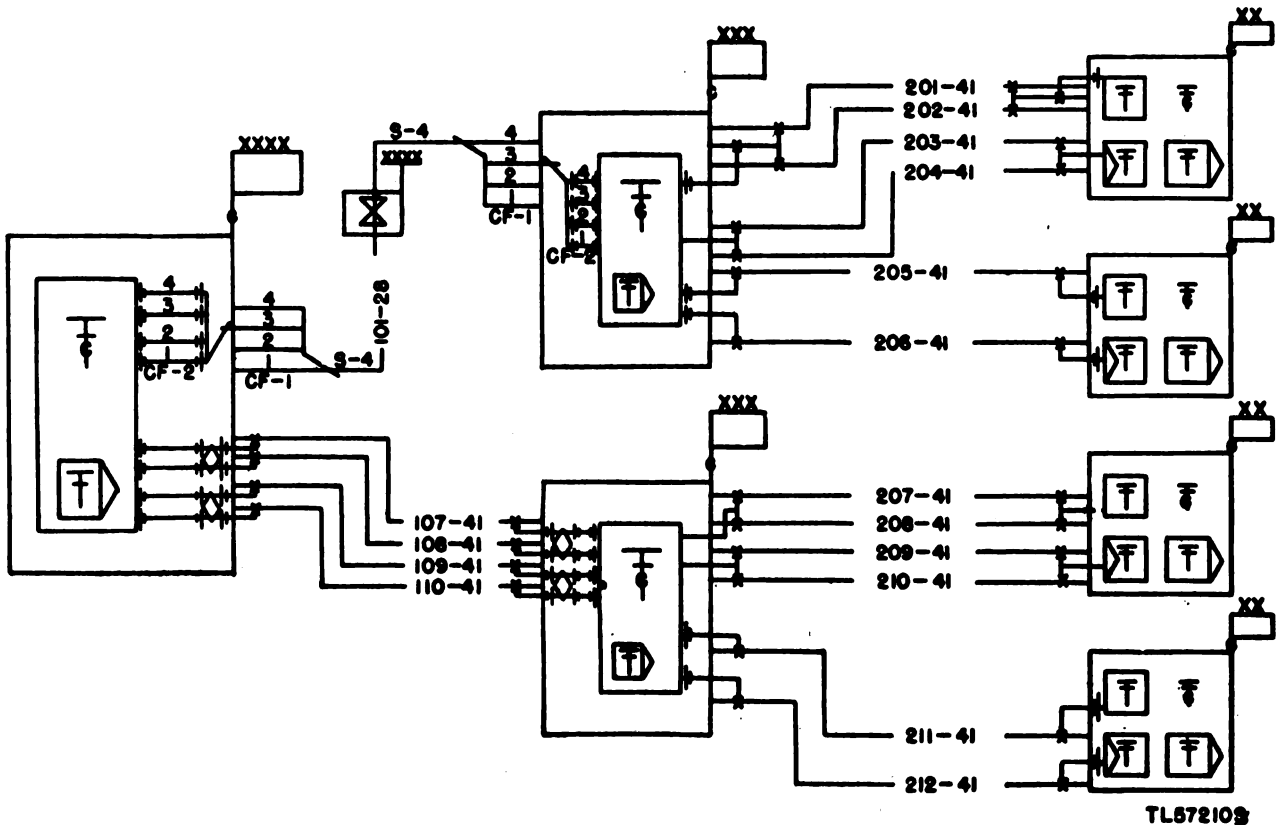

Figure 263. Simplified tactical circuit diagram.

teletypewriter communications; a number placed on that line indicates the number of channels available. The unit which each station serves is indicated by the call letters or code name appearing at that station. The traffic diagram is prepared at each teletypewriter station by the section chief, chief maintenance man, or chief operator. It is prepared from information received over the wire system and from the circuit diagram. It should show only such channels as are available for traffic. The main purpose of the traffic diagram is to indicate to operating personnel the most direct route to any other central of teletypewriter in the system and to show alternate routes if some circuits become out of order. It must be expanded as additional information is obtained, and corrected as changes occur. Figure 264 is an example of a simplified teletypewriter traffic diagram

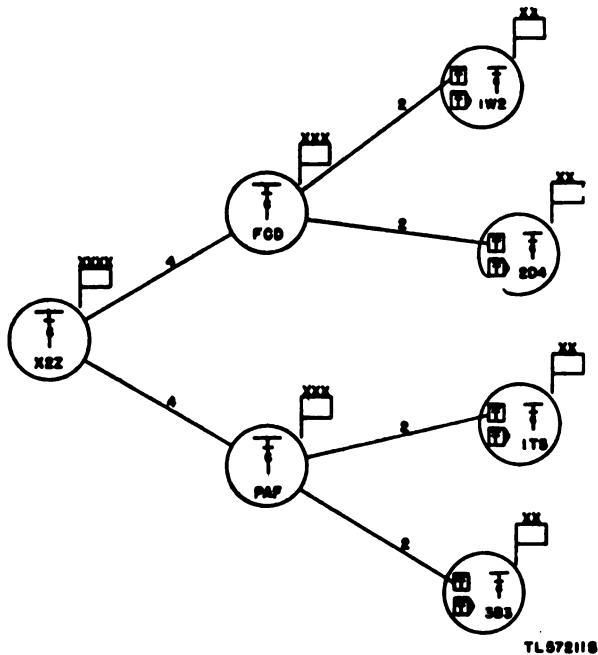

Figure 264. Simplified traffic diagram.

149. Station Records

a. Under tactical conditions certain channels are allotted to teletypewriter communication. These channels are allotted according to the amount of traffic foreseen, and it is vitally important that all associated teletypewriter equipment be in condition for efficient operation at all times. Preventive maintenance is very important in the continual use of teletypewriter equipment. As ordinarily practiced, preventive maintenance consists of periodic inspection, lubrication, and adjustment of the equipment

involved. If these preventive maintenance practices are performed in a haphazard manner, the equipment, naturally, can be expected to perform in a similar way which will mean continual break-down in teletypewriter communication. In order to keep an accurate check on the operation of all equipment for which he is responsible, the teletypewriter mechanic should keep a record of each piece of equipment. Trouble reports should be filled out when a case of trouble is reported. This facilitates the clearing of any future troubles that may appear on that particular equipment. A master routine schedule should be kept. This schedule should list all the routine jobs that are essential for the proper maintenance of teletypewriter equipment and the minimum frequency at which the jobs should be performed. A simple but complete filing system is a necessity in keeping complete records. The forms, schedules, etc., given in this manual are merely recommended lay-outs that can be used as guides in organizing a system for keeping records. In the preparation of these forms, due consideration should be given to the sequence of jobs to be performed with special emphasis on the importance of including all equipment and necessary operations. In general, operating personnel are responsible for the daily routine, and the teletypewriter mechanic is responsible for the weekly, monthly, and semiannual maintenance. Only trained maintenance personnel should be employed for clearing troubles.

b. Record cards should be kept on all equipment, but one card may include an entire set such as a Teletypewriter Set EE-97-(*), Reperforator Teletypewriter Set TC-16, etc. It is very important that all equipment cards be kept up to date at all times. If trouble is reported on some particular equipment, it takes only a few minutes to look up the record of that equipment. Usually any trouble encountered in teletypewriter equipment may be traced back to a trouble that occurred previously. Then, too, if a particular piece of equipment is constantly giving trouble, the record card will show it and the equipment may be taken out of service and given a thorough overhauling either at the station or at some repair depot. Figure 265 is an illustration of a recommended lay-out for equipment record cards. The trouble information is hypothetical and should not be construed as being part of the lay-out. The card in the figure is filled out for Teletypewriter Set EE-97-A, but the card may be used for other sets or for individual machines, switchboards, line units, rectifiers, etc. Changes may

line, the wire chief or his representative should be notified. The trouble, however, should be entered on the trouble report and the equipment record. The missing information can be obtained by contacting the wire chief when he has cleared the trouble. Normally, nothing is gained by keeping the trouble report after the trouble has been recorded on the equipment record card. A recommended lay-out for a trouble report is shown in figure 267. The trouble information is obtained from the operating personnel reporting the trouble. The maintenance man who rectifies the trouble should fill in the remainder.

TROUBLE REPORT	
(for all trouble affecting teletypewriter service)	
Location <u>BEAVER</u>	Tel. No. <u>BEAVER 12</u>
Reported by <u>H.W.</u>	Date and Hr. <u>5/24/13</u>
Equip. Designation and Trouble Reported	
EE-97-A, NR. 16 - CAN'T TRANSMIT, (NO PREVIOUS TROUBLE ON RECORD)	
Trouble found	
Date and Hr. Cleared _____ By _____	

TL 57232 8

Figure 267. Recommended lay-out for trouble report.

e. In a teletypewriter central where a large amount of equipment is involved, it may be necessary to keep records and schedules of the periodic routines and test of the equipment. This insures that each piece of equipment is checked and serviced when it should be, and prevents many future troubles. A basic routine schedule, when properly prepared, shows all the procedures essential in maintaining the equipment to which the schedule applies. The frequency at which the routines are to be performed should also be indicated. Figures 268 and 269 illustrate recommended lay-outs for routine schedules of Teletypewriter Set EE-97-A and Telegraph Central Office Set TC-3. Similar schedules can be devised for other sets that may be used in the central. Each job in the routine schedule is given a number to facilitate servicing. For example, the maintenance man may be instructed to perform job. No. 12 on EE-97-A, No. 16, which is shown on the routine schedule as the cleaning and adjustment of relay 41-C. The routine schedule should be posted for all operating and maintenance personnel to refer to when performing the various jobs. The maintenance man should have a trouble report form with him when testing or adjusting the equipment. This will

help to insure that any trouble encountered will be reported to the person in charge in order that it may be properly recorded. The frequency at which the jobs should be performed will not necessarily be as shown in figures 268 and 269. It will vary accord-

ROUTINE SCHEDULE FOR TELETYPEWRITER SET EE 97-A, No. 16		
Item	Job No.	Frequency
Clean Machine and Associated Frisp.....	1	Daily
Check Motor Speed.....	2	Daily
Inspect Ribbon.....	3	Daily
Check Rectifier Output.....	4	Daily
Check Line Current.....	5	Daily
Check Bias Adj.....	6	Daily
Clean Line Plugs.....	7	Weekly
Inspect for Bent Plugs, Frayed Cords, etc.....	8	Weekly
Test, Clean, Lubricate Machine.....	9	Weekly
Test Run Power Unit.....	10	Weekly
Inspect Fuses and Blow Fuse Indicators.....	11	Monthly
Clean, Adj. 41-C Relay.....	12	Monthly Semi-
Calibrate Bias Meter.....	13	Annually

TL 57233 8

Figure 268. Recommended lay-out for routine schedule of Teletypewriter Set EE-97-A.

ROUTINE SCHEDULE FOR TELEGRAPH CENTRAL OFFICE SET TC-3, No. 1		
Item	Job No.	Frequency
Clean all Associated Equip.....	1	Daily
Check Motor Speed of Operator's Ptr.....	2	Daily
Inspect Ribbon of Operator's Ptr.....	3	Daily
Check Rectifier Output.....	4	Daily
Check Line Current (all lines).....	5	Daily
Check Local Bias Adj. (all lines).....	6	Daily
Check Line Bias Adj. (all lines).....	7	Daily
Check all Signal Lamps.....	8	Daily
Check Night Alarm.....	9	Daily
Clean All Plugs.....	10	Weekly
Inspect for Frayed Cords, Bent Plugs, etc.....	11	Weekly
Test, Clean, Lubricate Operator's Ptr.....	12	Weekly
Test Run Power Unit.....	13	Weekly
Check All Fuses and Blow Fuse Indicators.....	14	Monthly
Clean, Adj. EE-97-A Relays.....	15	Monthly Semi-
Calibrate Bias Meter.....	16	Annually

TL 57234 8

Figure 269. Recommended lay-out for routine schedule for Telegraph Central Office Set TC-3.

JOB SCHEDULE FOR TELETYPEWRITER SET EE-97-A, No. 16

Date	1	2	3	4	5	6	7	8	9	10	11	12	13	14	15	16	17	18	19	20	21	22	23	24	25	26	27	28	29	30	31
Job.No.																															
1	+																														
2	+	+																													
3	+	+																													
4	+	+																													
5	+	+																													
6	+	+																													
7	+																														
8		+																													
9																															
10																															
11																															
12																															
13																															

151. Moistureproofing and Fungiproofing

a. **GENERAL.** The most prevalent troubles that occur because of the presence of moisture and fungi are failure of capacitors and resistors, shorts, break-downs in relay and magnet coils, and grounds caused by deterioration of insulation. In tactical areas, teletypewriter equipment is installed in tents, huts, or in underground dugouts. Ventilation is usually very poor under these conditions and the high humidity permits moisture to form on the equipment when the temperature of the equipment is lower than that of the surrounding air. If allowed to remain, the moisture will cause fungi to grow in as little as 1 or 2 days. Because of these conditions, it is essential that teletypewriter equipment used in tropical areas be treated against moisture and fungi as much as possible. The moistureproofing and fungiproofing treatment devised by the Signal Corps will, if properly applied, provide a reasonable degree of protection against these factors. Normally, third echelon and higher units are responsible for this treatment along with their regular repair routines. The varnish used in the treatment will permit the entrance of moisture at a slow rate, making it necessary that the treatment be repeated from time to time, depending on climatic conditions and the amount of use the equipment receives. The varnish used is a thin, air-drying liquid containing a fungicide. The entire treatment consists of testing, dismantling, cleaning, masking, drying, applying the varnish, and reassembling and checking the equipment. On equipment such as rectifiers, covers, cases, line units, etc., the varnish may be applied with the aid of a spray gun. However, on equipment such as teletypewriters and Switchboard BD-100 it is practically an impossibility to mask all places where varnish is detrimental to the functioning of the unit. Therefore, only a brush can be used to apply the varnish. In the following procedure, the two systems are covered separately.

b. **SPRAY METHOD.** (1) *Test of equipment.* All teletypewriter equipment to be treated should be in first-class condition before it is processed. All adjustments should be checked and the entire unit tested. Any defective part should be replaced.

(2) *Disassembly.* The unit should be partially disassembled to facilitate cleaning, necessary masking, and more thorough drying. This will also help to insure that all parts are covered when the varnish is applied. Be careful when removing the component parts to make sure that all circuit wiring is exposed. It may be necessary to remove some components

entirely to reach parts that otherwise are inaccessible. It also may be necessary to disconnect and even unsolder wires from terminals to enable the entire unit to be reached by the varnish spray. However, unsoldering wires from their terminals means time consumed in reassembling the unit. Therefore, only those soldered connections that would prevent other components from being exposed to the varnish spray should be disconnected. If some wiring is sewed in cable form, it is well to open the form so varnish will cover each individual conductor. In addition to generally dismantling the equipment, all parts that will be affected by heat and all parts that produce an excessive amount of heat in operation should be removed completely.

(3) *Cleaning.* With the equipment dismantled, a thorough cleaning can be accomplished. Carefully remove all dirt, corrosion, grease, oil, etc., since any foreign materials will prevent a continuous film of varnish. If available, a blower or compressed air hose can be used to good advantage in removing loose foreign particles. Rust and corrosion may be eliminated by the use of fine sandpaper. Solvent such as carbon tetrachloride or gasoline will remove grease and oil.

(4) *Masking.* After the unit has been thoroughly cleaned, mask all parts where varnish will interfere with electrical continuity or moving parts, or will in any way impair the operational efficiency of the unit. An adhesive masking tape is used for this purpose which can be applied directly to small parts. For the larger parts and areas, it is best to form paper around the part or area and hold it in place with the masking tape. When the masking operation is completed, carefully check the entire unit for exposed points where varnish will be detrimental to the operation of the unit. As an example, the following table lists the parts of Rectifier RA-43-B that should be masked. The masking of these parts is in addition to the removal of the tubes and lamps.

- (a) Tube sockets.
- (b) Lamp sockets.
- (c) Clips for C6J tubes.
- (d) Spade terminals.
- (e) Terminal screws.
- (f) Output receptacles.
- (g) Rectifier selenium-stacks.
- (h) Meter case and meter.
- (i) Microswitch.

(5) *Moisture removal.* It is necessary to remove completely all moisture from the unit before application of the varnish is begun. To do this, some means

of applying heat of approximately 160°F. must be used. Moistureproofing and fungiproofing Kits MK/2GSM utilize infrared lamps to supply heat directly to the unit being treated. If this kit is available, operating instructions will be included. Any steel chest, empty drum, or packing case of sufficient size may be used as an oven when the kit is not available. Probably the best of this type of oven is the packing case. It is easy to build and the materials are generally found where teletypewriter equipment is installed. Figure 271 is an example of this type oven. Six 50- to 100-watt lamp bulbs supply the heat and free circulation of air is maintained by vents placed in the top and bottom of the oven. A shelf to hold the equipment is formed by galvanized screen wire. A source of 110 to 115 volts alternating current is required. The time required for complete drying of the equipment depends on its size and condition. In general, about 2 or 3 hours will be sufficient at a temperature of 160° F. At higher temperatures wax or other insulating compounds may soften and even at 160° F. it is necessary to inspect the equipment at regular intervals for evidences of this trouble; a thermometer should be placed with the equipment in order to keep an accurate check on the temperature. In cases where it is necessary to lower the temperature of the oven, 1 hour must be added to the drying time for every 10° change. The temperature may be varied by blocking and unblocking the vent holes and varying the number and wattage of the lamp bulbs. If available, a fan placed in the oven will aid materially in

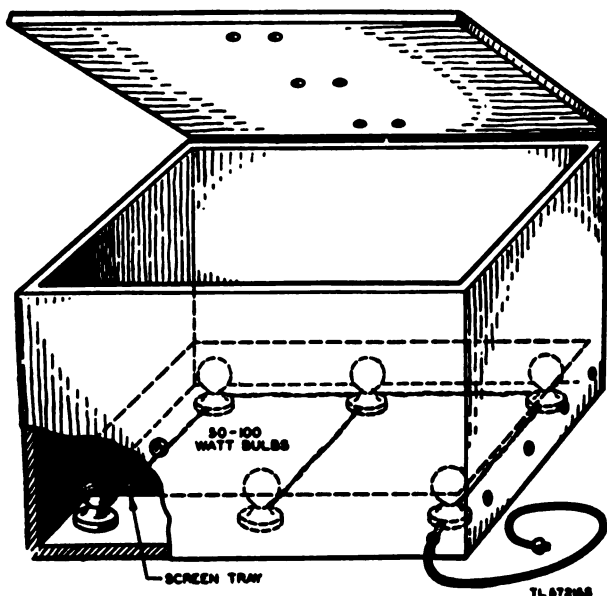

Figure 271. Packing case type oven.

decreasing the drying time by more evenly distributing the heat. In any event, the equipment in the oven should be turned at least once every ½ hour.

(6) *Varnish application.* The mixture of varnish and thinner should be about two parts varnish to one part thinner. It is far better to use the specially prepared varnish which contains a fungicide, but if that is not available other varnish (preferably clear) may be substituted. If kept clean, it will resist the growth of fungus better than other materials that may be used as field expedients such as wax compounds, paraffin, shellac, etc. The spray gun should be filled and made ready for operation before the equipment is removed from the oven. The varnish must be applied as soon as the equipment is taken from the oven and should be done, if possible, in a well ventilated tent, building, etc. This will prevent moisture accumulating before the varnish is applied and will also help to prevent dust and dirt from settling on the equipment before the varnish is dry. A well ventilated building will also dissipate the fumes. These fumes have a toxic effect, which makes it necessary that a respirator be worn by the person applying the varnish. If a respirator is not available, cheesecloth wrapped across the nose and mouth forms a very good substitute. A no-smoking rule should be strictly adhered to as the spray is very explosive in nature. Before actual spraying is begun, the equipment should be carefully checked to see that none of the masking has become loose or has been removed. Best results will be obtained if the gun is held at a 45° angle, about 12 inches from the area to be covered, and a very fine spray is applied in all directions. Extreme care is necessary to see that all equipment and wiring is completely covered with the exception of the masked terminals. After the equipment is covered as completely as possible with the spray gun, a small brush may be used to apply varnish to the untouched portions. The unit can then be placed in the oven to allow the varnish to dry (normally about 10 minutes) and the process repeated until three complete coats of varnish have been applied. The equipment must not be handled until it is perfectly dry.

(7) *Reassembly.* The masking can be carefully removed as soon as the equipment is completely dry and all points not covered can be touched up with the brush. It may be necessary to apply varnish to small points where the removal of masking tape may have caused the varnish to come off. Some contact points may have a thin film of varnish or some of the adhesive material sticking to them which

can be cleaned off by scraping or by using varnish remover. Varnish thinner cannot be used for this purpose as it will tend to thin the varnish, causing it to spread. The components may then be replaced and any wire forms that were opened resewed. During reassembly, the unit should be inspected for thoroughness of varnish application and any points not covered can be touched up with the brush. When completely assembled, the equipment should be given a complete operational check. This means a complete test of each mechanical and electrical operation. All teletypewriter equipment that has been moisture-proofed and fungiproofed should be stamped to indicate when the work was accomplished. A recommended method is to stamp the letters "MFP" (moistureproofed and fungiproofed) and the date at some obvious place on the unit. If a teletypewriter mechanic sees this notation, he will know that when any part is replaced or any repairs made, the connecting leads must be cleaned before any soldering is done and any new parts installed should be treated. The data on moistureproofing and fungiproofing should be entered on the equipment record card as an indication of the frequency at which the unit must be reprocessed.

c. BRUSH METHOD. (1) *General*. This method of treating teletypewriter equipment against moisture

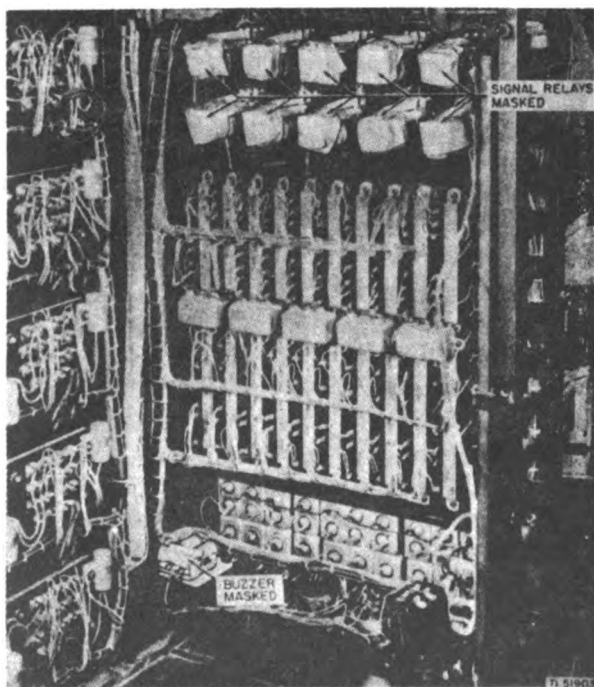

Figure 272. Switchboard BD-100 ready for varnish application.

and fungi pertains only to that equipment which cannot be masked against varnish spray. The following procedure is based on the model 15 teletypewriter and Switchboard BD-100 but may be applied to other teletypewriter equipment that is similar in construction. The varnish, of course, cannot be placed where it will interfere with the operation of the equipment. However, as much of the equipment as possible should be covered. Parts that are kept moving when the machine is in operation are not nearly as susceptible to fungus growth as those that are stationary. If correctly applied, the varnish will form an even, very thin coating and will not interfere with the equipment's operation unless critical places such as pivot points, bearings, contacts, etc., are coated.

(2) *Disassembly*. The equipment must be partially disassembled in order to apply the varnish to all wiring, capacitors, stationary parts, etc. Primarily, the only dismantling that should be necessary on a teletypewriter is the removal of the four major sections. It is also necessary to remove the bottom of the base to reach the wiring, capacitors, etc., that are located there. Switchboard BD-100 may be dismantled by removing the panels and positioning them as shown in figure 272.

(3) *Cleaning*. A thorough job of cleaning is necessary, particularly on the machine, since the parts to be covered with varnish must be completely free from oil and grease. If some type blower is available, it can be used to very good advantage on Switchboard BD-100.

(4) *Masking*. Be careful when application is made to be sure that contacts, terminals, etc., are not covered by the varnish.

(5) *Moisture removal*. Complete drying is necessary for both the machine and switchboard. The components of the equipment may be dried in an oven. If an ordnance truck is available and equipped with some sort of heating apparatus, it may be used as an oven for drying Switchboard BD-100 after all items that would be affected by the heat are removed from the truck. The switchboard may be dried in direct sunlight if no oven of sufficient size is available. A temperature of 160° F may be too high, as a number of capacitors are involved. Constant check on the condition of these capacitors is essential while the equipment is drying.

(6) *Varnish application*. The varnish should not be mixed with thinner when a brush is used. Greater care is necessary when brushing on the varnish than when it is sprayed in order to cover completely the

surface of the part that is being treated. Places that are difficult to reach with the brush are the points where fungi will first start because of lack of ventilation. Be very particular when applying varnish to the wiring, capacitors, and magnet and relay coils, because that is where fungi will cause the greatest amount of damage. Terminals, contacts, pivot points, etc., should not be varnished. Switchboard BD-100 must be air-dried if no suitable oven is available. This will take longer than with an oven, and while drying, the unit should be kept in a well ventilated location that is free from dust and dirt.

d. OTHER PREVENTIVES. In order for fungi to grow it must have moisture. Therefore, if moisture can be eliminated from teletypewriter equipment, no trouble of this type will be encountered. With tropical weather prevailing, it is virtually an impossibility to keep the equipment entirely free from moisture, however. Even with moistureproofed and fungiproofed teletypewriter equipment, fungus will grow unless the components that are constantly exposed to the atmosphere are kept dry. One method of accomplishing this is to use some type of oven. This method, however, is not practical in all installations because to dry the equipment in an oven, the unit must be taken out of operation. If the temperature of the equipment is kept slightly above the temperature of the surrounding air, condensation of moisture will not occur. A lamp bulb inclosed within the teletypewriter or switchboard will keep the temperature of that equipment as much as 5° warmer than the surrounding air. If heating is not practical, condensation of moisture can be lessened somewhat by the free circulation of air over the equipment. Moisture from the earth will rapidly condense on teletypewriter equipment when the equipment is installed on the ground. This can be counteracted somewhat by placing all equipment on tarpaulins, shelter halves, etc. All parts and tools should be kept in lockers located at the driest place possible. When it is necessary to remove tools from the locker for maintenance purposes, wipe them with an oily cloth before they are restored. The surface of some items can be wiped with a cloth saturated in a mixture of ethyl alcohol and fresh water (about two parts alcohol to one part water) to remove fungus that already has formed. This treatment, however, cannot be used on textile insulating materials. Once fungus has begun its growth, even though it is wiped off, it will reappear and will develop more rapidly than normal when moisture is again present. Some growths can be

retarded by the use of genuine camphor gum. One effective means of preventing fungus growth on teletypewriters is by moisture proofing and fungiproofing them as much as possible, and keeping a thin film of oil on all parts. This can be done by properly drying the machines in an oven, then spraying them with a light film of oil. It may be necessary to mix the oil with gasoline to get a satisfactory spray. Coils, contacts, platen, etc., must be protected from the oil spray. This is not a lasting application and the treatment must be repeated at frequent intervals.

152. Dust

Make every effort to prevent dust from settling on the equipment. Normally, dust can be removed by a blower of some type or by using a small brush. In tropical climates, however, dust is accompanied by high humidity which causes a crust to form on the surface of parts. If allowed to remain, this crust will result in incorrectly operating relays, sticky contacts, and, in some cases may affect the mechanical operation of a teletypewriter. All equipment should be cleaned frequently and thoroughly to prevent break-downs in teletypewriter communication. Good preventive maintenance practices are the best counteraction against troubles caused by dust and should be performed at regular intervals. The frequency at which the routines should be performed is governed by the location, weather conditions, etc.

153. Insects

Insects are a constant hazard to teletypewriter communication in tropical areas, particularly in switching arrangements. They gather in the equipment where they usually die, and their bodies cause short circuits. Termites (sometimes called white ants) are the greatest source of trouble as they will eat their way into relay coils, retard coils, etc., causing opens and shorts. Here again, preventive maintenance, in the form of constant cleaning is the best counteraction. Ventilator openings in the building, tent, or other structure where the teletypewriter equipment is located, should be covered with fine mesh screening to prevent the entry of insects. Small cups of oil placed beneath the legs of Switchboard BD-100 will provide a barrier to crawling insects.

154. Corrosion

Corrosion is greatly accelerated by the salt air in the hot, humid atmosphere of tropical areas. It may

penetrate so deeply into metals that tensile strength and lasting qualities are impaired. It appears as brown-red stain on iron and steel, white specks on aluminum, whitish powder on magnesium, and blue or green stain on copper. The varnish used in moistureproofing and fungiproofing and finishes applied to the equipment by the manufacturer serve as shields against corrosion, therefore be careful that these finishes are not scratched or removed. Preventive maintenance will prevent the removal of metal finishes due to the abrasive action of dirt, dust, etc. Keep tools well covered with oil as a protective measure against corrosion. If tools are to be stored, cover them with grease and wrap them in burlap. Replacements are very difficult to secure in theaters of operations, even though they are absolutely essential for proper maintenance of teletypewriter equipment. Never lay them on the ground or put them away without first being wiped with an oily cloth.

155. Tropical Storms

Severe electrical storms are frequent in tropical areas and unless teletypewriter equipment is properly protected, it can be damaged and even completely destroyed by lightning. It should be standard procedure to have each piece of equipment grounded and all lines equipped with lightning protectors. These precautionary measures are not only for the protection of the equipment but also are for protection of operating and maintenance personnel. If lightning protectors are not available, they can be improvised from material that normally is found at teletypewriter installations.

156. Operation in Arctic Climates

Most teletypewriter equipment will withstand storage satisfactorily at -65° F. Usually the equipment will operate in temperatures as low as 0° F, if certain modifications are made. These modifications are usually outlined in literature packed with the equipment. In some types of teletypewriter equipment provision is made for the installation of fuse blocks, so that 100-watt bulbs can be inserted for heating purposes. It has been found that application of kerosene to certain parts of equipment that are apt to crack from intense cold will minimize such cracking. However, such applications should never be attempted unless they are specifically directed by proper authorities. Special lubricants are usually prescribed for moving parts of equipment operated in extremely cold climates. Lubrication instructions

for operation in such climates are given in TM 11-352.

Section III. DESTRUCTION OF TELETYPEWRITER EQUIPMENT IN COMBAT ZONE

157. General Introduction

The object of this section is to impress upon teletypewriter mechanics the importance of knowing what equipment should be destroyed to keep the enemy from using it to his advantage in the event of its capture. The following instructions prescribe the general means of destruction applicable to various classes of teletypewriter equipment that are subject to capture or abandonment in a combat zone. The procedure outlined applies to teletypewriter facilities, whether military, nonmilitary, governmental, or commercial, when, in the judgement of the military commander, such action is necessary. Teletypewriter operating and maintenance personnel must be prepared and equipped at all times with means of totally destroying their equipment without delay when they are in a zone of combat.

158. Priority of Destruction

In the destruction of parts of equipment that are to be destroyed to an extent sufficient to prevent their future use or reclamation, the following priorities should be used:

a. NONSTANDARD PARTS. Parts that are nonstandard or unusual, from either a mechanical or electrical standpoint, should be destroyed first since there is little likelihood that the enemy can replace them.

b. CRITICAL UNITS. All critical units should be destroyed after the nonstandard units because there is little likelihood that the enemy can replace them in a short period of time.

c. INTERCHANGEABLE PARTS. Parts that are interchangeable should be destroyed as a third step to prevent the enemy from using them to salvage other equipment that may have been abandoned by other tactical outfits.

d. OTHER PARTS. All other parts, including all printed material, should be completely destroyed to keep them from being used by the enemy in any way.

159. Means of Destruction

The most common means of destruction of teletypewriter equipment is the 16-pound sledge hammer

that usually is located at each teletypewriter installation in the field. The sledge is of sufficient weight to smash completely all teletypewriter equipment. Other means of destruction that may be used, preferably in conjunction with the sledge, are hand grenades, fire, submersion in water, and burial. *It must be remembered, however, that the hand grenade is very dangerous and all personnel within the vicinity should be warned before it is used.* Generally speaking, it is not as satisfactory as fire, and for the most part, is used only when evacuation is necessarily rapid.

160. Procedure of Destruction

a. GENERAL. In the demolition of teletypewriter equipment each unit must be smashed and destroyed separately in the order described in the succeeding subparagraphs. This is extremely important inasmuch as the various units to be destroyed are described in the order of their relative value for both machine operation and for critical value in enemy hands as possible salvage or replacement.

b. SWITCHBOARD BD-100. Using a sledge hammer or axe, shear off all rheostat knobs and keys. Open the back of the switchboard and completely smash all relays, including the slow-acting relay and the line and local relays. Smash all capacitors, resistors, coils, etc. Cut all wiring and batter all jacks and terminal strips as much as possible; cut all patching cords and render the plugs unusable. Smash panel face, meter, etc., and knock off top, bottom, and sides. If time permits, either pile the entire unit with inflammable material and burn it or dump it into the deep part of a stream or other body of water.

c. TELETYPEWRITER TG-7-(*). The basic field machine is Printer TG-7-A or Teletypewriter TG-7-B. The procedure and order for destruction of the individual units of this machine are as follows:

(1) *Selector magnets and line relay.* Crush completely with a sledge or hammer.

(2) *Selector mechanism.* Bend and break the selector armature, selector levers, T-levers, and swords. Bend the separator plates. Cut all wiring. Crush the selector cam sleeve, breaking off all projections and the stop arm. Break the range finder mechanism, especially the stop lever and pin.

(3) *Gears.* All gears on the main shaft and the motor pinion, and the transmitting shaft gear, should be broken beyond repair.

(4) *Keyboard.* Bend and break the keyboard contact assembly. Bend and break key levers, selec-

tor bars, locking levers, and contact levers. Smash the cam sleeve and completely mutilate the casting beyond any means of salvage or repair.

(5) *Motor.* Cut all wires. Break bushings at each end. Cut and burn the field and armature windings. Break the casting.

(6) *Platen assembly.* Completely break the platen assembly with the sledge hammer.

(7) *Printing unit.* The entire printing unit, including the type basket, can be completely destroyed with a few heavy blows of the sledge hammer.

d. RECTIFIERS. (1) *Rectifier RA-43-(*).* Smash all tubes, transformers, meter, microswitch, terminal block, capacitors, selenium stack, etc. All wiring should be completely cut and burned and the casting demolished with a sledge hammer. If available, an axe should be used to cut up the metal cover of the rectifier. The instruction plate that is fastened to the metal cover should be destroyed with an axe, burned and buried, or thrown into a stream.

(2) *Rectifiers RA-37, RA-87, REC-10, REC-12, REC-13.* These rectifiers are all of the selenium stack or copper-oxide type and can be completely destroyed with a sledge hammer. Give special attention to the rectifying stacks and the transformers and capacitors. The metal cover should be cut up with an axe and burned. If instruction plates or circuit diagrams are fastened to the covers they must be destroyed.

e. LINE UNIT BE-77-(*). Smash the unit with the sledge hammer, making sure that the relay is beyond any possibility of repair and that the rheostat, capacitors, transformer, wiring leads, and terminals are also completely demolished. Cut and burn all wiring. Pay particular attention to wiring diagrams and instruction plates on the sides of the line unit. These must be destroyed.

f. POWER UNITS PE-77-(*), AND PE-75-(*). If sufficient time is available, the power units should be speeded up and short-circuited to burn out the windings. Break the cylinder head, engine block, spark plugs, carburetor, and gas tank. Cut all wiring and hose connections. Smash the coupling between the engine and generator and break the complete casting. Destroy the armature and field windings of the generator and break the bushings at both ends. Break off brushes and commutator; cut all wires; crack the main casting. Make sure the shaft is bent.

g. OTHER TELETYPEWRITER EQUIPMENT. Other teletypewriter equipment, some not intended for field use, may be used in zones close enough to the zone

of combat to be vulnerable to raiding sorties, paratroop attacks, etc. The manner of destruction of items in this category is also given so that destruction may be carried out with the greatest amount of speed and efficiency. The equipment should be destroyed in the same order as their counterparts given in the preceding subparagraphs.

(1) *Teletypewriter model 19 composite set.* This set is often used in air force teletypewriter networks and may be found at some of the forward airfields or bases. The machine should be destroyed the same way as is Teletypewriter TG-7-(*), plus the complete destruction of the punch and tape feed mechanisms. The control contact assembly can be rendered useless by bending and breaking. The transmitter distributor must be completely destroyed. Break up the transmitter by smashing the operating arm, operating cam, contact lever bail, contact levers, contact tongues, contacts, and the entire tape feed mechanism. Smash and cut the stop magnets, all wiring and terminal connections, and smash the main shaft and all associated gears and clutch. Give particular attention to the commutator rings when smashing the distributor. The motor can be destroyed in the same way as described for the motor of Teletypewriter TG-7-(*).

(2) *Reperforator transmitters TG-26 and TG-27.* These sets are similar to the TG-7-(*), so far as their operation is concerned and they should be destroyed in the same manner and order plus the complete destruction of the punch and tape feed mechanisms.

(3) *Keyboard perforator.* Break and smash the punch mechanism, tape feed mechanism, punch magnet, yoke, and armature. Break all contacts. Smash the relay on the under side of the unit. Cut all wires, and bend and break key levers.

(4) *Reperforators (nontyping).* Destroy the selector unit in the same way as outlined for Teletypewriter TG-7-(*). The punch and tape feed mechanisms and all gears, mainshaft, etc., can be demolished with a sledge hammer. The main castings and frame can also be smashed with a sledge hammer.

h. PRINTED MATERIAL. The destruction of all printed matter, including circuit traffic and wiring diagrams, records, manuals, and instructions must be absolutely complete. The quickest and most efficient means of accomplishing this is by using gasoline that may be obtained in the field from the supply kept for power units. All paper should be piled in stacks, saturated well with gasoline, and the entire collection ignited from a safe distance. If gasoline is not available, other inflammable material such as wood, leaves, etc., can be used. Wooden cases of the different teletypewriter components should also be destroyed by complete burning and care should be taken to make sure that all schematic and wiring diagrams and instruction cards that may be fastened to the cases are completely burned. An incendiary grenade will greatly aid in the destruction of printed matter.

i. EXPEDIENTS. If time does not permit the complete destruction of all teletypewriter equipment by sections as outlined, it should be destroyed as much as possible and dumped into a stream or other body of water. Any means of keeping the equipment from being of any use to the enemy should be used. All destroyed equipment should be piled together, saturated with gasoline, and burned and buried if sufficient time is available. When the available time is extremely short, a few hand grenades thrown into the equipment will render it useless for some time.

APPENDIX

GLOSSARY OF TERMS USED IN TELETYPEWRITER MAINTENANCE

The following glossary contains explanations of the technical terms used in this manual.

Adapter. An accessory used to change or alter an electrical plug, or the like to render it suitable for a new mounting.

Bail. A hoop or ring; a half-hoop or horseshoe shaped piece used as a support. An arched metal bow to which motive power is attached or through which motive power is delivered. Used to complete the transfer of power to other parts for a particular operation.

Bell-crank. A lever whose two arms form an angle with its fulcrum at the apex of the angle.

Bias. Line bias: the effect on the length of telegraph signals produced by the electrical characteristics of the line and equipment. If the received signal is longer than that sent, the distortion is called *marking bias*; if the received signal is shorter, it is called *spacing bias*.

Bias, applied. A force (electrical, mechanical, or magnetic) exerted on a relay or other device which tends to hold the device in a given electrical or mechanical condition.

Bias distortion. The distortion produced by bias.

Bias meter. A meter for measuring the amount of marking or spacing bias that may be present in a transmitted signal.

Break contact. That contact of a switching device which opens a circuit upon the operation of the device.

Break key. On a teletypewriter, the key used to break into the transmission being received from another station.

Bridge. A shunt path; a device used in the electrical measurement of impedance, resistance, etc.

Bushing. A metallic sleeve, usually removable and replaceable, inserted in a body to resist wear. Electrical: a lining for a hold that insulates a through conductor.

Bypass. A shunt path around some element or elements of a circuit.

Cam. A projecting part of a wheel or other moving piece of machinery for imparting motion.

Capacitance. The ability or capacity to receive an electrical charge.

Capacitive reactance. The effect of capacitance in opposing the flow of alternating current.

Capacitor. A device for inserting the property of capacitance into a circuit; two or more conductors separated by a dielectric.

Carrier current. A current upon which is impressed a current of another frequency to transmit intelligence.

Carrier frequency. The frequency of the carrier current.

Centrifugal. Proceeding or flying away from the center.

Centrifugal force. A force which impels a body, or parts of a body, outward from the center of rotation.

Characteristic. A distinguishing trait, quality, or property.

Choke coil. A coil winding of small resistance and large inductance, used to impede or throttle the current. A reactor.

Closed-circuit system. A telegraph system in which, when no station is transmitting, the circuit is closed and current is flowing in the circuit.

Composite. A method of simultaneously operating telephone and direct-current telegraph circuit over the same conductors in which one telegraph circuit may be obtained on each conductor.

Clutch. A device for mechanically coupling two working parts.

Continuity. A condition of a circuit where a closed electrical path is obtained.

Cross. A type of line trouble in which one circuit becomes connected to one or more other circuits.

Cross-fire. A condition where telegraph signals on one circuit cause interference in other telegraph or telephone circuits.

Cycle. In a periodic phenomena, one complete set of recurring events.

Decibel. A unit of transmission expressing a relation between input and output power.

- Detent.** A stop or checking device, as a pin, lever, etc., on a ratchet wheel or the like.
- Differential.** Pertaining to, or involving, a difference; that is, a differential current device is one which operates upon the basis of a difference in two current values.
- Distortion.** An alteration or a deformity of a waveform.
- Dowel.** A pin, usually of circular shape, fitting into corresponding holes in abutting pieces.
- Drop.** An electrically operated mechanical device on a switchboard line circuit which is used to indicate an incoming call.
- Duplex.** Operation in two directions simultaneously over one circuit.
- Eccentric screw.** A screw whose shaft is off-center.
- Electromagnet.** A core of magnetic material, such as soft iron, with a coil of wire surrounding it. The electromagnet is temporarily magnetized by an electric current passing through the wire coil, but loses its magnetism after the electric current ceases to flow.
- Escapement.** A device which controls the motion, and through which energy is delivered at regular intervals.
- Filter.** A device for preventing the passage of current of certain frequencies while allowing currents of other frequencies to pass.
- Frequency.** In periodic phenomena the number of vibrations or cycles in unit time; in alternating current the number of cycles per second.
- Friction.** Resistance encountered when one surface slides over another surface.
- Friction clutch.** A clutch or coupling operating by friction for engaging or disengaging revolving parts.
- Friction feed.** Using the friction between two bodies to force-feed something.
- Function.** The duty or job performed by a device. With regard to teletypewriters, the mechanical operation of line feed, carriage return, space, letters shift, figures shift, unshift on space, and motor stop.
- Fuse.** A wire, bar, or strip of fusible metal inserted as a safety device in an electric circuit. When the current increases beyond the rated strength of the fuse, the metal melts and thus interrupts the circuit.
- Fusetron.** A fuse equipped with an overload feature. A fusetron will take a starting load up to 50 percent in excess of its rated value for a short period of time before blowing. Has a base connection similar to a fuse.
- Fusstat.** A fuse equipped with an overload feature the same as a fusetron, but having a different base connection. Must be used with an adapter for insertion into a fuse socket.
- Gear.** A set of appliances as of cog wheels, serving to transmit motion or change its rate or direction.
- Governor.** An automatic attachment to a motor for controlling the speed of rotation.
- Ground.** The contact of a conductor with the earth; also the earth wherf employed as a return conductor.
- Grouping circuits.** Circuits used to connect two or more switchboard positions together so that one operator may handle the operation of those positions from his own operator's set.
- Harmonics.** Frequencies of exact multiples of a fundamental frequency.
- Holding coil.** A separate coil of a relay which is energized by the operation of the relay and holds the relay operated after the original operating circuit is de-energized.
- Impedance.** The total opposition to the flow of current, consisting of resistance and reactance.
- Inductive reactance.** The opposition to the flow of alternating or pulsating current due to the inductance of the circuit.
- Insulators.** A nonconducting substance or body.
- Jack.** In combination with a plug, a device by which connections can readily be made in electrical circuits.
- Key.** A hand-operated device for the rapid opening and closing of a circuit or circuits.
- Keyboard perforators.** A mechanism consisting of a keyboard and a perforator, by which means a tape is perforated in accordance with a code corresponding to the depressed character key of the keyboard.
- Latch.** To secure or fasten as with a catch.
- Leakage.** Term used to express current loss through imperfect insulation.
- Lever.** A mechanical device; a beam pivoted on a fixed point or fulcrum, serving to impart pressure or motion to exert effective power.
- Lockwasher.** An open, spiral, spring tempered steel washer for preventing the loosening of nuts.
- Loop.** Subscriber's loop: The pair of conductors connecting a subscriber's instruments with the main frame of the central office. Loop mile: the resistance of a pair of conductors between two

- points 1 mile distant; the resistance of the two conductors connected in series.
- Make contact.** That contact of a device which closes a circuit upon the operation of the device.
- Marking bias.** That bias which affects the results in the same direction as marking current.
- Marking contact.** That contact of a telegraph relay which is closed when marking current is controlling the relay operation.
- Marking current.** That magnitude and polarity of current in the line when the receiving mechanism is in the operated position.
- Microfarad.** Practical unit of capacitance; one-millionth of a farad.
- Milliamperé.** Unit of electric current; equal to one-thousandth of an ampere. Usually referred to as ma.
- Multiple.** Parallel connection to provide multiple paths whereby a number of pieces of equipment may be connected into the circuit.
- Ohmmeter.** A direct reading instrument for measuring resistance, calibrated in ohms.
- Opm.** Operations per minute.
- Overlap.** The selecting of another code group while the printing of a previously selected code group is taking place.
- Patching.** Temporarily connecting together two lines or circuits by means other than switchboard cord circuits.
- Patching cord.** A cord terminated on each end with a plug, used in patching between circuits terminated in jacks.
- Pawl.** A hinged or pivoted piece, shaped to engage with ratchet teeth; a click or detent.
- Perceptible.** Capable of being perceived, discernible: can be seen or felt.
- Period.** The time required for the completion of one cycle.
- Phantom circuit.** A telephone circuit which is superimposed upon two other circuits so that the two conductors of one circuit act combined as one conductor for the phantom circuit, and the conductors of the second circuit act as the other phantom conductor.
- Pilot.** A guide.
- Pivot.** A point or fixed pin, on the end of which something turns.
- Platen.** The part of a typewriter or teletypewriter, on which the paper is supported, to receive the impression.
- Plug.** In combination with a jack a device by which connections can readily be made in electrical circuits.
- Polar.** A system of telegraphy in which the current in the line is reversed in polarity in changing from marking to spacing.
- Polarential.** A telegraph transmission system in which transmission in one direction is polar with equal and opposite transmitting voltages for marking and spacing, and transmission in the other direction is differential with voltage applied for the spacing condition and ground for the marking condition.
- Polarised plug.** A plug that is so constructed that it can be inserted into an outlet in only one way.
- Prolongation.** That interval of time between the opening of the circuit and the release of the receiving mechanism.
- Pulsating current.** Current of varying magnitude but constant direction.
- Range.** The upper and lower limits through which the index arm of the range-finder mechanism of a teletypewriter may be moved and still receive correct copy.
- Ratchet.** A mechanism consisting of a notched wheel, the teeth of which engage with a pawl, to permit motion of the wheel in one direction only.
- Rectifier.** A device for changing alternating current to pulsating direct current.
- Repeater.** A device for the retransmission of a signal, usually with amplification.
- Repeating coil.** An audio-frequency transformer for transferring energy from one electrical circuit to another, usually one-to-one ratio with one side (line connection) arranged so that a center tap may be obtained for simplexing.
- Reperforator.** A device for receiving teletypewriter signals as electrical impulses from a line and converting them into perforations in a tape.
- Retardation coil.** A coil offering high impedance to voice frequency currents but low impedance to direct current.
- Rheostat.** A variable resistance for limiting the current in a circuit.
- Rotor.** The rotating part of an electrical device.
- Shaft.** An axle or other long and usually cylindrical bar (especially if rotating), subject to torsional stress.
- Shaft bearing.** The part of the shaft that bears the friction.
- Shield.** A screen or device which protects electrical

- apparatus from being affected by electrostatic or magnetic fields.
- Shunt.* A parallel or alternate path for the current in a circuit; usually with some impedance other than zero; not used with reference to trouble.
- Simplex.* A method of obtaining an additional telegraph channel by the use of repeating coils.
- Sleeve.* A tube surrounding a shaft to permit motion of itself or of the shaft.
- Sounder.* A receiving instrument used in telegraphy to produce signals by means of an armature operated between two stops.
- Spacer.* A device for holding two members at a given distance from each other.
- Spacing contact.* That contact of a telegraph relay which is closed when a spacing impulse is controlling the relay operation.
- Spacing impulse.* That period of time in which the circuit polarity of current is reversed or, in a neutral system, when the signal line is opened, the receiving mechanism is caused to be in the unoperated or released position.
- Spur gear.* A simple form of toothed wheel, with radial teeth parallel to the axis of the wheel.
- Stator.* Stationary part of electric motor which contains the field coils.
- Supervision.* The process of watching over the condition of a connection at a switchboard to determine when subscribers are through using the connection.
- Switch.* A device for opening, closing, or rerouting an electrical circuit.
- Switchboard.* A board containing apparatus for controlling or connecting electrical circuits.
- Synchronism.* The state of being synchronous.
- Synchronous.* Having the same period and phase; happening at the same time.
- Telegraphy.* A means of communication whereby a message is transmitted, a character at a time, employing a code of impulses of various lengths and combinations to designate the individual characters. Teletypewriter transmissions are a form of telegraphy and teletypewriters are sometimes referred to as telegraph printers.
- Telephone.* An instrument for the converting of speech into electrical waves for transmission and converting electrical waves to sound waves for reception.
- Teletypewriter.* An electromechanical device for the transmission of characters as electrical impulses, and the reception and printing of characters to correspond with the impulses received.
- Teletypewriter code.* A special code in which each code group is made up of five units or elements of equal length. These units or elements are known as marking or spacing impulses.
- Terminal.* One end of an electrical circuit.
- Tolerance.* The allowable limits of adjustment within which the mechanism will operate.
- Transmitter distributor.* A motor-driven device which translates teletype code combinations from fully perforated or chadless paper tape into electrical impulses and transmits these impulses to one or more receiving stations.
- Trunks.* A circuit between two switchboards, central offices; switchboard positions, or other parts of a wire plant, but not to any subscriber.
- TWX.* A trunk between teletypewriter central offices. In the Army, TWX usually refers to trunks from Army teletypewriter switchboards to commercial switchboards; or a message that has been transmitted through a commercial teletypewriter exchange.
- Voice frequencies.* Those frequencies covered by the range of human voice (usually below 3,000 cycles per second).
- Wick.* Loosely twisted braided or woven cord that, when saturated with oil, will supply lubrication to moving parts.
- Working margin.* The difference between the current in a receiving instrument when the distant operator's key is marking and when it is spacing; that is, line current less leakage.
- Yield spring.* An elastic body or contrivance that yields under stress and returns to its normal form when the stress is removed; normally used to take up the motion or cushion the action of a lever.
- Zero bias.* When the received signal is equal to the transmitted signal (neither longer nor shorter), the circuit is said to have zero bias.

INDEX

	<i>Paragraph</i>	<i>Page</i>
American and British field equipment, interoperation.....	59	64
American equipment, mechanical modifications.....	63	69
Arctic climates, operation	156	212
Associated symbols, meaning	148b	201
Bias:		
Distortion	118a	135
Effect of on receiving mechanisms.....	118c	136
End distortion	118b	135
End distortion, effect of on receiving mechanisms.....	118d	136
Internal	118e	136
Measurement circuit	97	99
British Teletypewriter 7B (WD):		
Answer-back unit	60g	66
Features	60	64
Keyboard transmitter	60b	66
Motor and motor control.....	60f	66
Printing apparatus	60d	66
Receiving mechanism	60c	66
Selector codes	60a	65
Signal bell	60h	66
Speed	60e	66
Cable, armored	34a	38
Carrier systems, theory	8	9
Circuit:		
Full-metallic	4b	5
Ground-return	4c	5
Circuit diagram	148d	203
Circuits, interconnection	19	21
Components, various	136f	158
Conduit	34b	38
Connections, station-to-station	93	93
Destruction in combat zone	157	212
Destruction:		
Means	159	212
Priority	158	212
Procedure	160	213
Diagram, tactical, introduction	147	200
Direct-current systems, theory	2	1
Distortion, effects	11c	12
Dust, removal	152	211
Electronic voltage regulator	136e	157
Emergency arrangements	52f	56
Equipment:		
Location	50	51
Setting	50	51
Equipment features, general introduction.....	25	29
Expedients, destruction	160i	214
Field equipment:		
Functioning of parts	53	56
Introduction	37	44

	<i>Paragraph</i>	<i>Page</i>
Ground connections, testing	76	82
Ground rods, use	3d	3
Grounds	3	2
Good, how to obtain	3c	3
Poor, effects	3b	2
Incoming call, answering	92	92
Insects, protection against	153	211
Inspection	137	158
Jacks, use	26b	29
Leakage, line	7	8
Lighting	33	38
Line current adjustment	52c	55
Line current measurement circuit	96	99
Line relay circuit	89	91
Line transmission features	101	108
Line Unit:		
BE-77-(*), destruction	160e	213
BE-77-A	41	45
BE-77-A:		
Operating circuits	54	56
Bias circuit	54f	59
Line circuit	54a	58
Line circuit with relay out.....	54c	58
Measurement of line current.....	54d	59
Selector magnet circuit	54b	58
Maintenance procedures, general	57	62
Microswitch and associated circuits	136b	153
Moisture proofing and fungiproofing	151	208
Brush methods	151c	210
Preventives, various	151d	211
Spray method	151b	208
Motor generators	30c	36
M-15 teletypewriter tables	27	30
M-19 teletypewriter tables	28	34
Neutral operation, d-c systems	2b	1
Noise in radio receiver, elimination	35	39
Operation procedure	65	72
Operator's teletypewriter holding circuit	88	90
Operator's teletypewriter, three-party conference with	94	97
Permanent installation	82	87
Personnel, protection	36a	39
Phantom circuits	5c	6
Plant and equipment, protection	36b	40
Plugs and cords, use	26c	29
Polar operation, direct-current systems	2c	1
Power source:		
Connections	51	52
Test of	34d	39
Power sources	30	36
Power Unit:		
PE-77-(*)	44	49
PE-75-()	72	78
PE-77-(*) and PE-75-(*), destruction	160f	213
Printed material, destruction	160h	214
Printer:		
TG-7-A69, 89	76, 45
TG-7-A, power-selector switches55, 69	60, 76

	<i>Paragraph</i>	<i>Page</i>
Records, station, introduction	147	200
Rectifier:		
RA-37	43b	48
RA-43- ()	70	76
RA-43- (), installing	74	78
RA-53	71	78
RA-87	43a	48
RA-89	43c	49
REC-10	31b	36
REC-13	31c	37
REC-29 and REC-30	31d	37
Rectifiers:		
Destruction	160d	213
Fixed station	31	36
General introduction	127	145
Testing procedures	132	149
Vacuum tube	134	151
Vacuum-tube rectifier operation, theory	135	152
Trouble-shooting procedures	133	150
Regenerative Repeater OA-3/FC	105	117
Regenerator unit RED-8	107	118
Relay:		
Adjustment	52d, 117	55, 134
Contact, adjustment	117a	134
Pole-piece adjustment	117b	134
Relay 299-AN	62a	68
Relay, 41-type	58	64
Relays, neutral	42	46
Repair and servicing	137	158
Repeater TG-30 (terminal, telegraph)	100	107
Repeaters:		
Regenerative	23	25
Using two	20	21
Repeating coil:		
Effects of on transmission	5b	6
Theory	5	5
Reperforator Teletypewriter Sets:		
TG-16 and TG-17	47	50
Power connections	51b	52
Signal circuit connections	52b	55
Reperforator Transmitter TG-26-A and TG-27-A	48, 56	50, 61
Return circuits, metallic and ground	4	5
Safety devices	36	39
Schematic and actual wiring diagrams, use	83	89
Selenium rectifiers	128	128
Capacitor filter	131	147
Capacitor, power factor	131	149
Choke coil, filter	131	147
Components, circuit	131	146
Full-wave rectifier	130b	146
Half-wave rectifier	130a	146
Operation, theory	130	146
Rectifying elements, construction	129	145
Regulator, voltage	131f	149
Resistor, bleeder	131d	149
Transformer	131c	147
Semipermanent installation	81	86
Service and repair	98	100
Signal and line characteristics, general introduction	9	9
Signal circuit connections and line-up	52	54
Signaling the operator	91	92

	<i>Paragraph</i>	<i>Page</i>
Signal relay circuit	90	91
Simplex and phantom circuits, way stations in	5e	7
Simplex circuit, theory	5b	6
Simplex-phantom circuit	5d	7
Space requirements	32	38
Spacing, repeater	21	24
Station records	149	204
Storage batteries	30b	36
Storms, tropical	155	212
Switchboard:		
BD-100	68	72
BD-100, connections of to commercial systems:		
Introduction, general	108	120
Bias measurement	109f	125
Description	109	121
Destruction	160b	213
Installation and operation	75, 100	79, 125
Maintenance	111	127
Method of supervising	109d	122
Operation	78, 110c	84, 126
Operation, circuit, sequence	109e	122
Parts, functioning	84	89
Power requirements	109a	122
Relay, local, circuit	85	89
Signal lamp circuit (line open key in)	87	90
Signal lamp circuit (line open key out)	86	90
Signal lines, connection and line-up	110b	125
Transmission features	109b	122
Use, preparation for	110a	125
Switchboards	48	50
Switchboards, multiple connections	77	83
Symbols:		
Application	148c	202
Associated, meaning	148b	201
For tactical diagrams, basic	148	200
Teletypewriter, meaning	148a	201
Tables XRT-97 and XRT-106, connections	27b	30
Tables XRT-115 and XRT-116	29	35
Tactical diagrams and station records, introduction	147	200
Telegraph central office equipment:		
General	67	72
Installation procedures	73	78
Introduction	66	72
Telegraph Repeater OA-6/FC, general	104	113
Teleprinter 7B (WD), circuits	61	66
Teleprinter Terminal Unit Mark IV	62	68
Teletypewriter:		
AN/TGC-3:		
Circuit operation	140e	170
Connections:		
Control circuit	140d	170
Power and ground	140b	168
Signal line	140d	170
Installation and operation	140	168
Test, local	140c	170
TG-7-B	40, 69	45, 76
Power selector switches	55	60
TG-7-(*), destruction	160c	213
TG-37-B	46	49
TT-10/FG:		
Adjustments, local	141c	176

	Paragraph	Page
Circuit operations	141e	178
Connections:		
Power and ground	141b	176
Signal line	141d	178
Installation and operation	141	176
Tests, local	141c	176
TT-10/FG and AN/TGC-3:		
Construction	138b	164
Description	138	164
Operation, land line	139b	166
Power requirements	139c	167
Radio operation	139a	165
Transmission features	139	165
Teletypewriter equipment:		
Tropical and Arctic maintenance of, general introduction	150	207
Various, destruction	160g	213
Teletypewriter equipment and d-c repeaters:		
Introduction	99	107
Installation and operation	102	112
Line transmission features	101	108
Maintenance	103	114
Transmission features	106	118
Teletypewriter Set:		
AN/TGC-1	142	186
Break circuit	145g	194
Break key, operation	145i	195
Call-in circuits	145p	198
Circuit, break	145q	198
Circuit operation	145	191
Circuits, call-in	145p	198
Connections:		
Ground	144b	188
Line	144d	191
Local	144c	191
Power	144b	188
Description	143	186
Feed-out key FO-1, operation	145m	196
Feed-out key FO-2, operation	145n	196
Half-duplex operation	145l	195
Installation	144	188
Magnet, number transmitter, operation	145e	193
Neutral receiving circuits	145k	195
Neutral send circuits	145h	194
Number release key, operation	145d	193
Number transmitter, operation	145c	193
Operation of, preparation	146	199
Polar send circuits	145g	194
Polar receive circuits	145j	195
Power connections	144b	188
Relay RA or RB, operation	145b	191
Transmitter A or B, operation	145e	193
Transmitter, number, operation	145c	193
Transmitting relays A and B, operation	145f	194
Typing reperforators, locking	145o	197
EE-97-(*), EE-98-(*), and EE-102, power connections	51a	52
EE-98 and EE-102	45	49
EE-97-(*), EE-98-(*), and EE-102, signal circuit connections	52a	54
Teletypewriter signals, nature	10	10
Teletypewriter symbols, meaning	148s	201
Teletypewriter systems, military and commercial connection	24	26
Teletypewriter switching central, typical large	79	84

	<i>Paragraph</i>	<i>Page</i>
Temporary installation	80	85
Terminal unit Mark IV, modifications.....	64	71
Test Set:		
CA-405-A:	113	128
Circuit test	113 <i>b</i>	128
Final checks	113 <i>f</i>	130
Pole-piece adjustment	113 <i>e</i>	130
Relay test	113 <i>c</i>	129
Relays, adjustment	113 <i>d</i>	129
ED-55-AJ	118, 120	135, 138
Bias meter test	119 <i>c</i>	138
Installation and use	119 <i>a</i>	137
Teletypewriter selector units, test.....	119 <i>b</i>	137
I-181	114	130
I-193-A	116	133
A-c checks	116 <i>b</i>	133
Bias test	116 <i>c</i>	133
General description	115 <i>a</i>	131
Power connection	116 <i>a</i>	133
Relay test	115 <i>b</i>	131
Sensitivity test	116 <i>d</i>	133
TS-2/TG:		
Description	121 <i>a</i>	139
Calibration	123	140
Electrical operations	121 <i>c</i>	140
Mechanical operations	121 <i>b</i>	139
Use	122	140
TS-383/GG	125, 126	143, 145
Bias test	125 <i>b</i>	143
Distortion test sets, various, calibration.....	125 <i>f</i>	144
Electrical characteristics	124 <i>c</i>	141
End distortion test	125 <i>c</i>	144
General description	124 <i>a</i>	140
Internal bias	125 <i>d</i>	144
Mechanical operation	124 <i>b</i>	141
Relays and repeaters, testing.....	125 <i>e</i>	144
Selector units, range determination.....	125 <i>a</i>	143
Tests, various	125 <i>g</i>	145
Use	125	143
Test sets, general introduction.....	112	128
Tyratron tube	136 <i>d</i>	156
Traffic diagram	148 <i>e</i>	203
Transformers	136 <i>a</i>	153
Transmission principles, general	1	1
Tropical and Arctic maintenance of teletypewriter equipment, introduction.....	150	207
Tropical storms	155	212
Trouble shooting	137	158
Vacuum-tube rectifiers, circuit components.....	136	153
Voltmeter	136 <i>c</i>	154
Wire, gage	34 <i>c</i>	39
Wiring, external	34	38

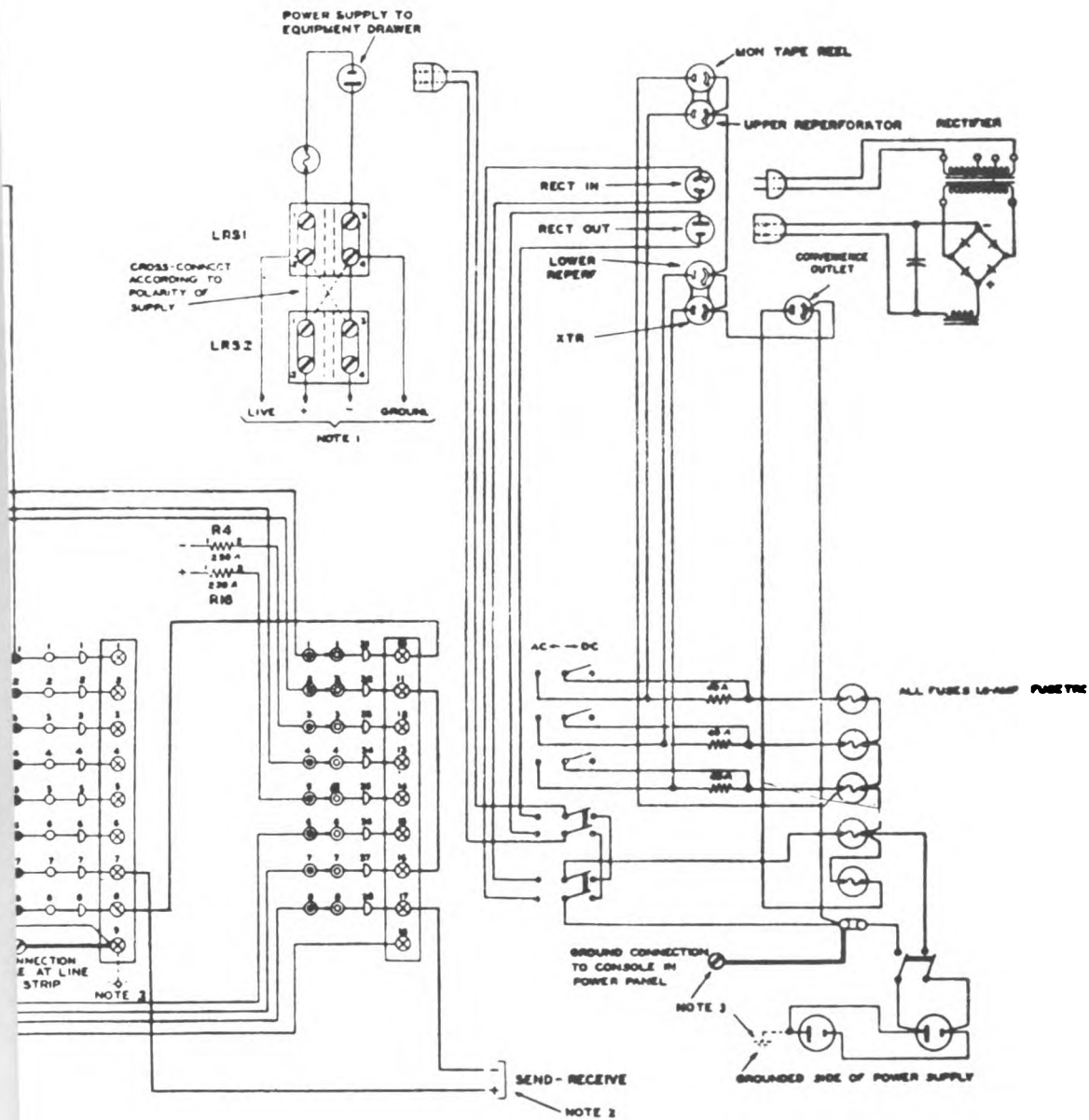

NOTES

- 1 LIVE CONNECTS TO ALL POINTS MARKED L ON DIAGRAM
 + CONNECTS TO ALL POINTS MARKED + ON DIAGRAM
 - CONNECTS TO ALL POINTS MARKED - ON DIAGRAM
 GROUND CONNECTS TO ALL POINTS MARKED G ON DIAGRAM
- 2 THE + AND - SIGNS ON THE EXTERNAL LINE LEADS MERELY INDICATE CORRECT POLARITY FOR SIGNALING BATTERY. THESE POINTS ARE NOT CONNECTED TO BLOCK LRS2.
- 3 THESE POINTS ARE PHYSICALLY GROUNDED. WHEN POWER IS SUPPLIED TO EQUIPMENT DRAWER FROM THE RECTIFIER THERE WILL BE NO PHYSICAL GROUND IN THE EQUIPMENT DRAWER AND THEREFORE NO CONNECTION BETWEEN LRS1-4 AND THE POINTS MARKED "NOTE 3".
- 4 SA1, SA2, SA3, SA4, AND SA5 = FIVE SECTION ROTARY SWITCH "SPLIT-NORMAL"
 SB1 AND SB2 = TWO SECTION ROTARY SWITCH "DUPLEX-DOUBLE"
 S1 AND S2 = TOGGLE SWITCHES "OP-NON-OP"
 S3 AND S4 = TOGGLE SWITCHES "POLAR-MAKE AND BREAK"
- 5 BASED ON WESTERN UNION TELEGRAPH CO DRAWING P-10724

PL 5029-0

Handwritten text, possibly a list or index, oriented vertically on the right side of the page. The text is difficult to read due to the orientation and quality of the scan.



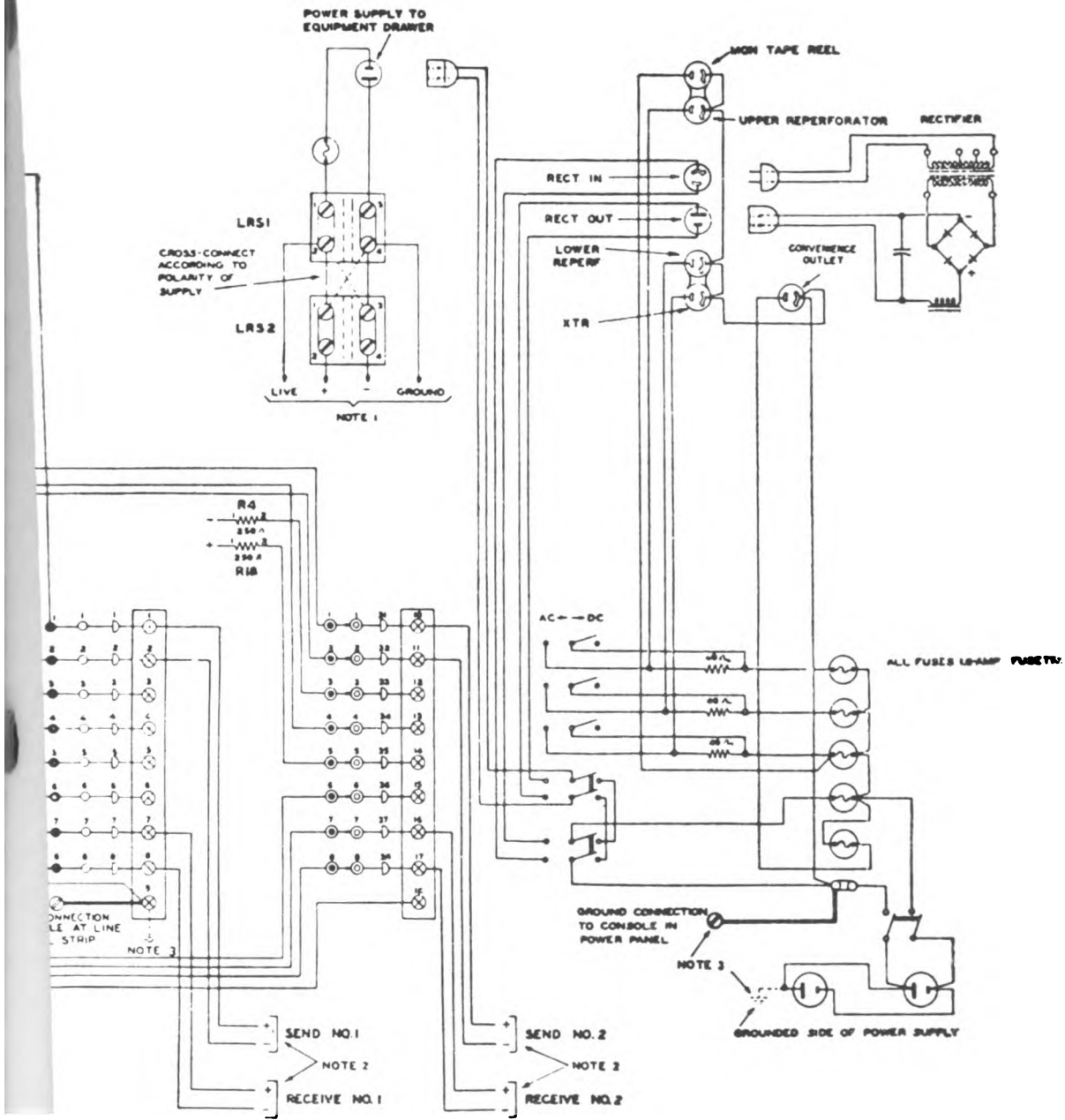

- NOTES:**
- 1 LIVE CONNECTS TO ALL POINTS MARKED L ON DIAGRAM
 + CONNECTS TO ALL POINTS MARKED + ON DIAGRAM
 - CONNECTS TO ALL POINTS MARKED - ON DIAGRAM
 GROUND CONNECTS TO ALL POINTS MARKED \perp ON DIAGRAM
 - 2 THE + AND - SIGNS ON THE EXTERNAL LINE LEADS MERELY INDICATE CORRECT POLARITY FOR SIGNALING BATTERY. THESE POINTS ARE NOT CONNECTED TO LOCK LRS2.
 - 3 THESE POINTS ARE PHYSICALLY GROUNDED. WHEN POWER IS SUPPLIED TO EQUIPMENT DRAWER FROM THE RECTIFIER THERE WILL BE NO PHYSICAL GROUND IN THE EQUIPMENT DRAWER AND THEREFORE NO CONNECTION BETWEEN LRS1-4 AND THE POINTS MARKED "NOTE 3"
 - 4 SA1, SA2, SA3, SA4, AND SA5 = FIVE SECTION ROTARY SWITCH "SPLIT-NORMAL"
 SB1 AND SB2 = TWO SECTION ROTARY SWITCH "DUPLX-SINGLE"
 S1 AND S2 = TOGGLE SWITCHES "OP-NON-OP"
 S3 AND S4 = TOGGLE SWITCHES "POLAR-MAKE AND BREAK"

7. 578723

9. BASED ON WESTERN UNION TELEGRAPH CO DRAWING P-10328

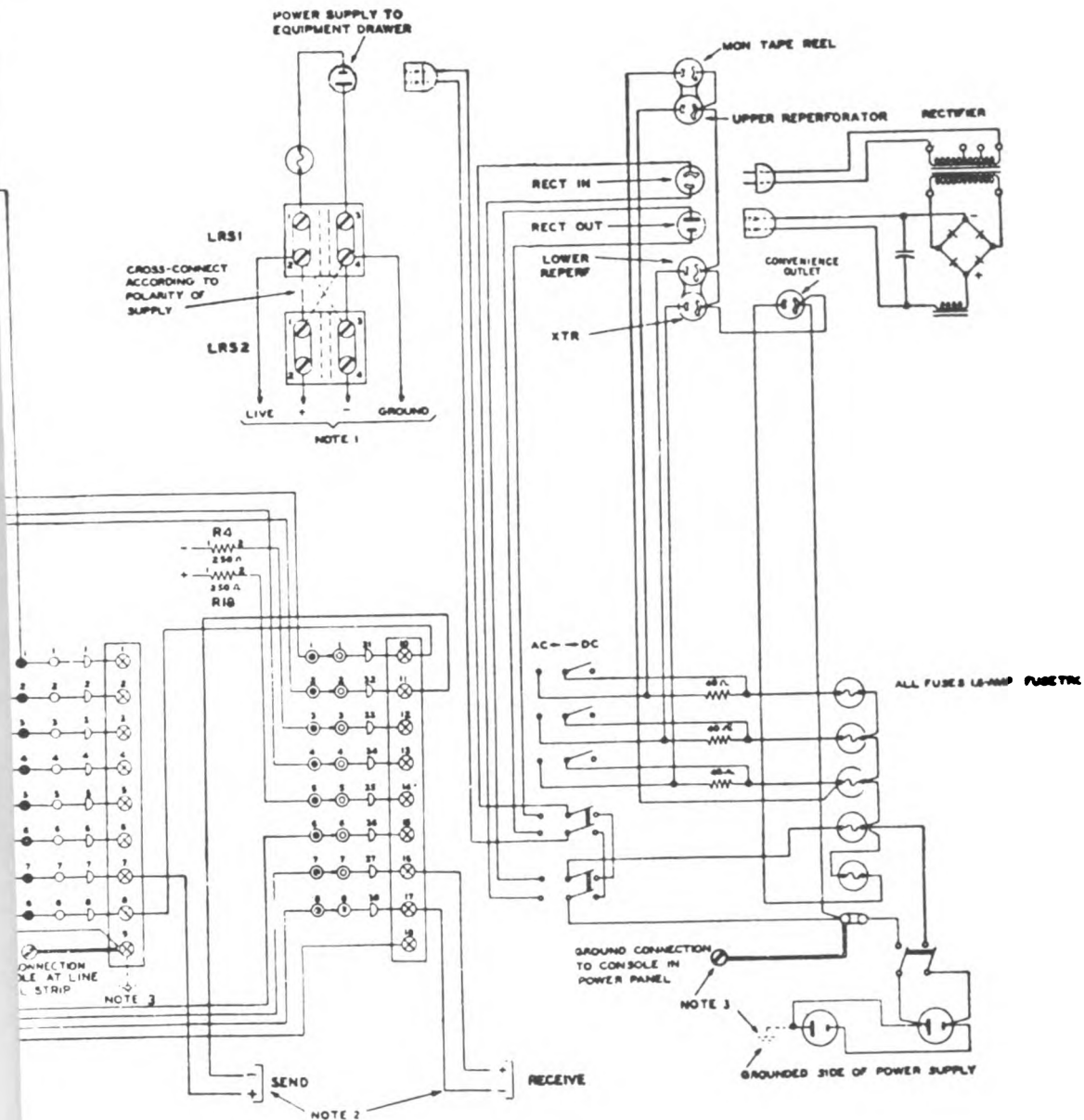

NOTES

1. LIVE CONNECTS TO ALL POINTS MARKED L ON DIAGRAM
 + CONNECTS TO ALL POINTS MARKED + ON DIAGRAM
 - CONNECTS TO ALL POINTS MARKED - ON DIAGRAM
 GROUND CONNECTS TO ALL POINTS MARKED \perp ON DIAGRAM

2. THE + AND - SIGNS ON THE EXTERNAL LINE LEADS MERELY INDICATE CORRECT POLARITY FOR SIGNALING BATTERY. THESE POINTS ARE NOT CONNECTED TO BLOCK LRS2.

3. THESE POINTS ARE PHYSICALLY GROUNDING. WHEN POWER IS SUPPLIED TO EQUIPMENT DRAWER FROM THE RECTIFIER THERE WILL BE NO PHYSICAL GROUND IN THE EQUIPMENT DRAWER AND THEREFORE NO CONNECTION BETWEEN LRS1-4 AND THE POINTS MARKED "NOTE 3"

4. SA1, SA2, SA3, SA4, AND SA5 = FIVE SECTION ROTARY SWITCH "SPLIT-NORMAL"
 SB1 AND SB2 = TWO SECTION ROTARY SWITCH "DUPLEX-SINGLE"
 S1 AND S2 = TOGGLE SWITCHES "OP-NON-OP"
 S3 AND S4 = TOGGLE SWITCHES "POLAR-MAKE AND BREAK"

5. BASED ON WESTERN UNION TELEGRAPH CO DRAWING P-10225

TL57796

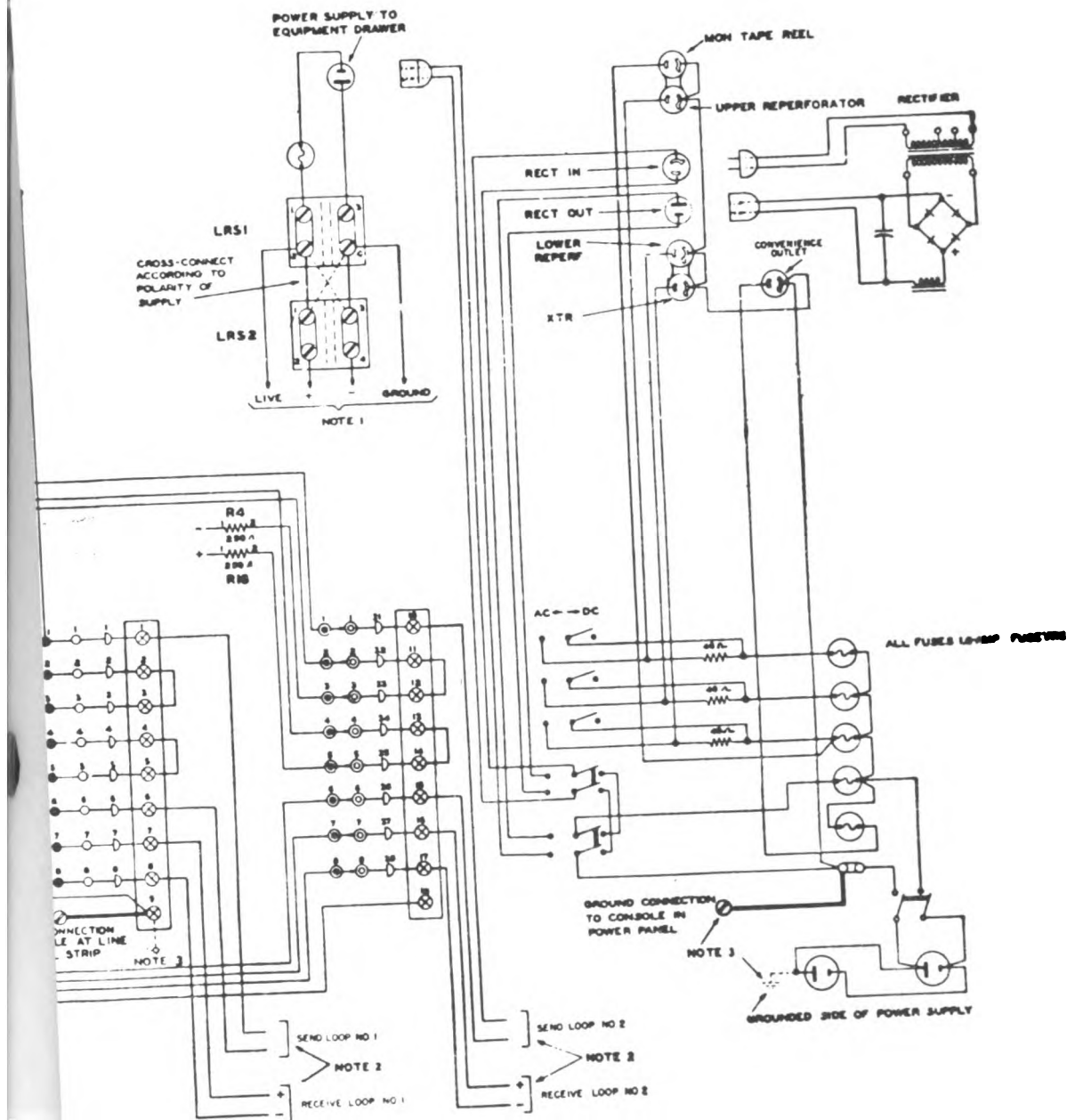

NOTES

1 LIVE CONNECTS TO ALL POINTS MARKED L ON DIAGRAM
 + CONNECTS TO ALL POINTS MARKED + ON DIAGRAM
 - CONNECTS TO ALL POINTS MARKED - ON DIAGRAM
 GROUND CONNECTS TO ALL POINTS MARKED ⚡ ON DIAGRAM

2 THE + AND - SIGNS ON THE EXTERNAL LINE LEADS MERELY INDICATE CORRECT POLARITY FOR SIGNALING BATTERY. THESE POINTS ARE NOT CONNECTED TO BLOCK LRS2.

3 THESE POINTS ARE PHYSICALLY GROUNDED. WHEN POWER IS SUPPLIED TO EQUIPMENT DRAWER FROM THE RECTIFIER THERE WILL BE NO PHYSICAL GROUND IN THE EQUIPMENT DRAWER AND THEREFORE NO CONNECTION BETWEEN LRS1-4 AND THE POINTS MARKED "NOTE 3"

4 SA1, SA2, SA3, SA4, AND SA5 = FIVE SECTION ROTARY SWITCH "SPLIT-NORMAL"
 SB1 AND SB2 = TWO SECTION ROTARY SWITCH "DUPLEX-DUPLEX"
 S1 AND S2 = TOGGLE SWITCHES "OP-NON-OP"
 S3 AND S4 = TOGGLE SWITCHES "POLAR-MAKE AND BREAK"

5 BASED ON WESTERN UNION TELEGRAPH CO DRAWING P-10273

71.572700

||| १४६ |||

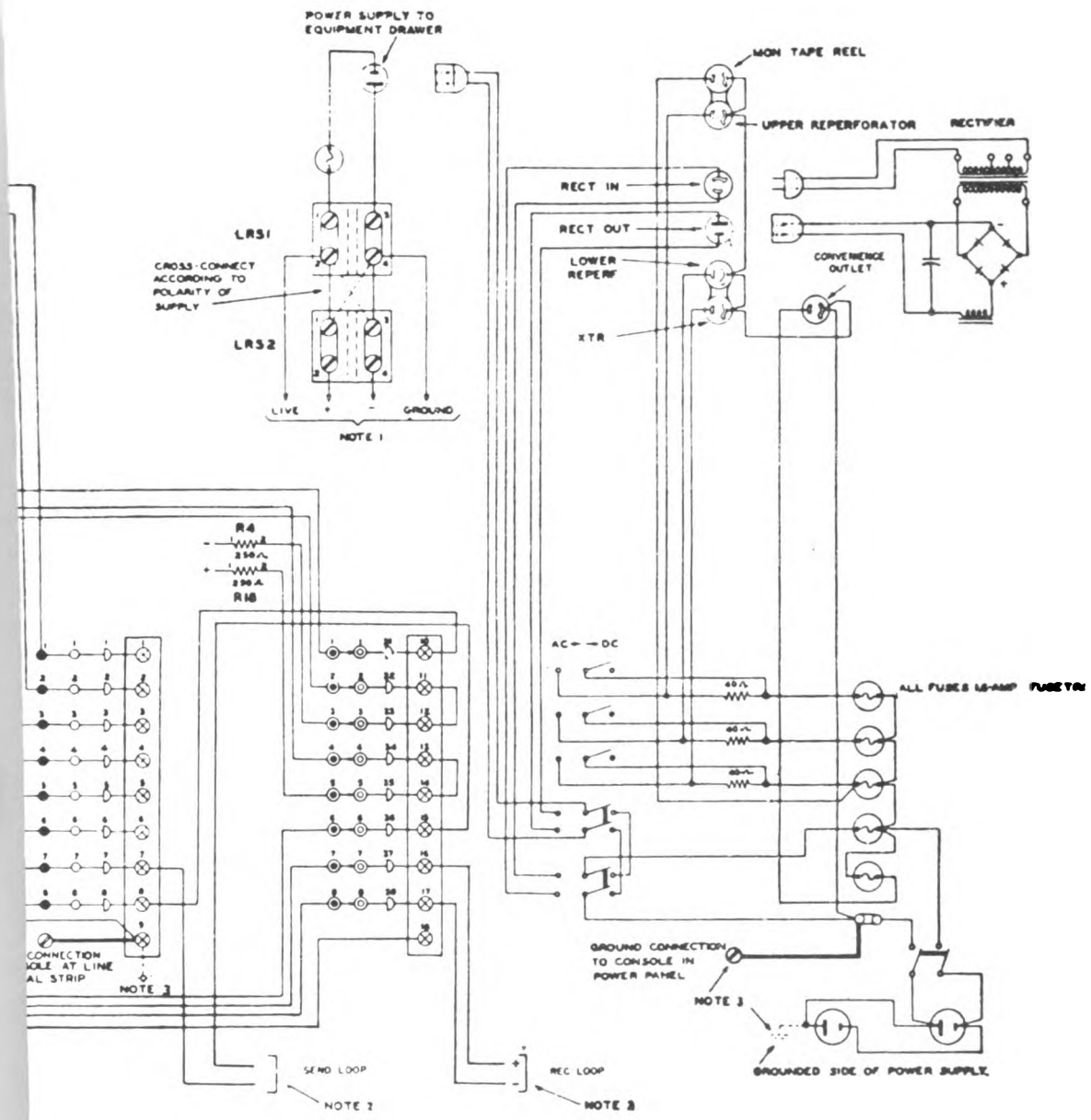

- NOTES
1. LIVE CONNECTS TO ALL POINTS MARKED L ON DIAGRAM
 + CONNECTS TO ALL POINTS MARKED + ON DIAGRAM
 - CONNECTS TO ALL POINTS MARKED - ON DIAGRAM
 GROUND CONNECTS TO ALL POINTS MARKED G ON DIAGRAM
 2. THE + AND - SIGNS ON THE EXTERNAL LINE LEADS MERELY INDICATE CORRECT POLARITY FOR SIGNALING BATTERY. THESE POINTS ARE NOT CONNECTED TO BLOCK LRS2.
 3. THESE POINTS ARE PHYSICALLY GROUND, WHEN POWER IS SUPPLIED TO EQUIPMENT DRAWER FROM THE RECTIFIER THERE WILL BE NO PHYSICAL GROUND IN THE EQUIPMENT DRAWER AND THEREFORE NO CONNECTION BETWEEN LRS1-4 AND THE POINTS MARKED "NOTE 3"
 4. SA1, SA2, SA3, SA4 AND SA5 = FIVE SECTION ROTARY SWITCHES "SPLIT-NORMAL"
 SB1 AND SB2 = TWO SECTION ROTARY SWITCH "DUPLER-SINGLE"
 S1 AND S2 = TOGGLE SWITCHES "OP-NON-OP"
 S3 AND S4 = TOGGLE SWITCHES "POLAR-MAKE AND BREAK"
 5. BASED ON WESTERN UNION TELEGRAPH CO DRAWING P-10222

1.00000



ALTERNATIVE METHOD OF SUPPLYING DC TO TRANSMITTER DISTRIBUTOR RELEASE MAGNET
 OPERATE TRANSMITTER DISTRIBUTOR RELEASE MAGNET ON DIRECT CURRENT FROM RECTIFIER. MOVE STRAPS 39-41 AND 38-42 ON BLOCK "B" D STRAPS 37-39 AND 35-38 ON BLOCK "B" MOVE STRAP FROM RESISTOR OF TRANS. DIST. LEAVE MAGNET SO THAT 25Ω IS IN THE CIRCUIT.

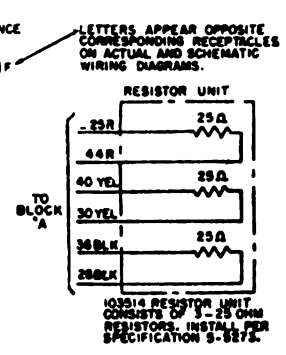
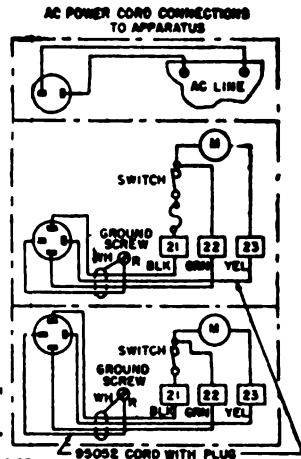
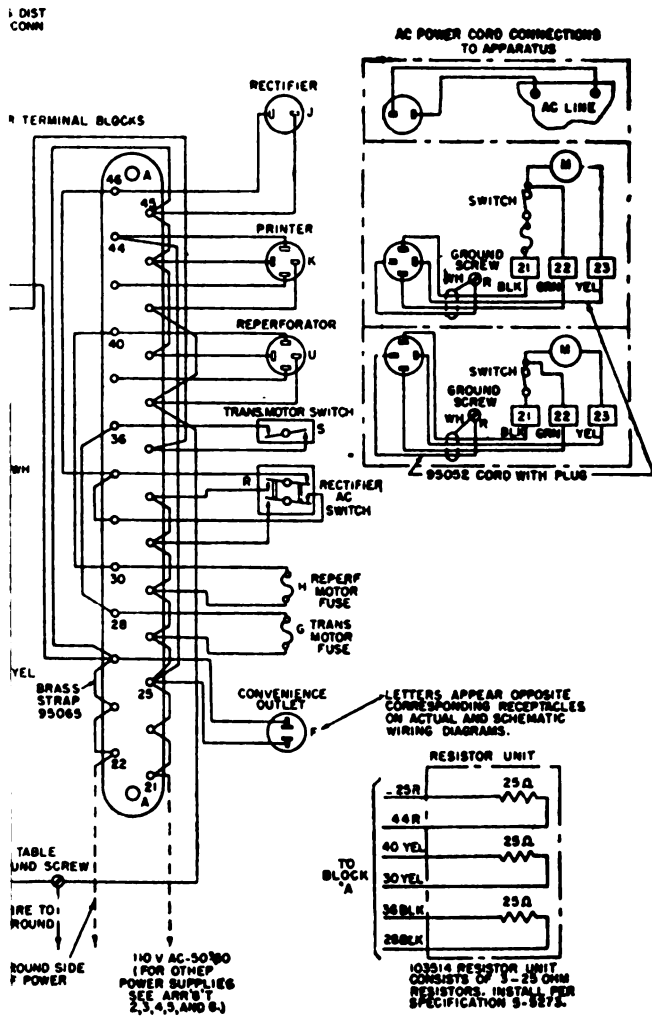

COLOR CODE

BLK	BLACK
WH	WHITE
RD	RED
GRN	GREEN
YEL	YELLOW
BLU	BLUE

110 V AC-50/60 (FOR OTHER POWER SUPPLIES SEE ARN'S 2, 3, 4, 5, AND 6.)



