

“DATASPEED®” PRINTER

RECORDER AND PAPER TRANSPORT

DISASSEMBLY AND REASSEMBLY

CONTENTS	PAGE
1. GENERAL	1
2. RECORDER	2
3. PAPER TRANSPORT	3
Paper Tensioner Mechanism	4
Platen and Paper Guideplate	5
Line Feed Mechanism	6
Idler Roller Mechanism	7
Paper Guide Mechanism	8
Separating the Frame From the Base	9, 10
Line Feed Magnet Assembly and Pre-Paper Puller Mechanism	11, 12
Line Feed Motor and Capacitor	14
Paper Tensioner Motor and Capacitor	14
Power Supply	15

1. GENERAL

1.01 This section provides disassembly and reassembly instructions for the recorder and paper transport mechanism of the DATASPEED printer. The disassembly procedure first separates the recorder from the transport, then divides the transport into major subassemblies. The procedure is in the reverse order to that normally used in the assembly of a new unit. If further disassembly is required, refer to Section 578-500-800 (formerly Section 592-820-800), which shows detailed arrangements of parts.

1.02 Most maintenance, lubrication, and adjustments can be accomplished simply by removing the units from the enclosure. If possible, disassembly should be confined to subassemblies, which can, in some cases, be removed without disturbing adjustments. When reassembling subassemblies, be sure to check associated adjustments, clearances, and spring tensions.

1.03 If a part that is mounted on shims is removed, note the number of shims used at each of its mounting screws so that the same shim pile-up can be replaced when the part is remounted.

1.04 To remove some components it is necessary to disconnect or unsolder electrical connections. Wherever possible, disconnect the electrical connections before removing the component mechanically. Note the connections before removing the leads, so the leads will be properly reconnected in reassembling the unit.

1.05 Retaining rings are made of spring steel and have a tendency to release suddenly. To avoid loss of these rings when removing them, proceed as follows: Hold the retaining ring to prevent it from rotating. Place the blade of a screwdriver in the ring slot. Rotate the screwdriver to increase the ring diameter. The ring will come off easily without flying.

1.06 Avoid loss of springs in disassembly by holding one spring loop with one hand while gently removing the other loop with a spring hook.

Note: Do not stretch or distort springs while removing or replacing them. Check spring tensions as described in Section 578-500-700 (formerly Section 592-820-700).

1.07 In removing a subassembly from the unit, note the procedure followed and the location from which parts are removed so that the unit can be reassembled correctly. Where no specific instructions are given for reassembly, reverse the procedure used in removing the subassembly. Follow the adjustment sequence in Section 578-500-700 (formerly Section 592-820-700), to make or check adjustments which may have been affected by disassembly.

1.08 Refer to Section 570-005-800 for the tools required to disassemble and reassemble the recorder and transport.

1.09 All references to right, left, top, bottom, etc, refer to the recorder and transport as viewed from the front. Unless otherwise noted, the photographs in this section show the left or right front views of the units.

CAUTION: REMOVE POWER FROM SET BEFORE BEGINNING DISASSEMBLY PROCEDURES.

2. RECORDER

2.01 The recorder is mounted on the front of the paper transport as shown in Figure 1. If the recorder alone is to be disassembled from the transport, it is not necessary to remove the transport from its mounting place in the base of the cover assembly on the printer cabinet. However, to remove the transport for further disassembly, it is advisable to remove the complete recorder/paper transport assembly from the base, then separate the recorder from the transport before attempting any further disassembly of the transport. See Section 578-500-702 for instructions on removing the recorder/paper transport assembly.

2.02 The recorder can be removed from the paper transport as follows:

- (1) Remove the cover assembly from the base on the top shelf of the printer cabinet.
- (2) Unplug all external connections to the recorder.

- (3) Remove the two TP151630 screws, TP2191 lockwashers, and TP151610 flat washers securing the left side bracket of the recorder to the bracket on the left side frame of the transport.

- (4) Remove the two TP151630 screws and TP2191 lockwashers, and the TP125015 (top) and TP151610 (bottom) flat washers securing the right side bracket of the recorder to the bracket on the right side frame of the transport.

- (5) Carefully raise the recorder assembly so that the projections on the top of its mounting brackets clear the brackets on the side frames of the transport.

CAUTION: KEEP THE RECORDER IN AN UPRIGHT POSITION TO AVOID SPILLING THE INK. THIS INK HAS POWERFUL STAINING PROPERTIES.

- (6) Rest the recorder on a level surface where there is no possibility of its tipping over.

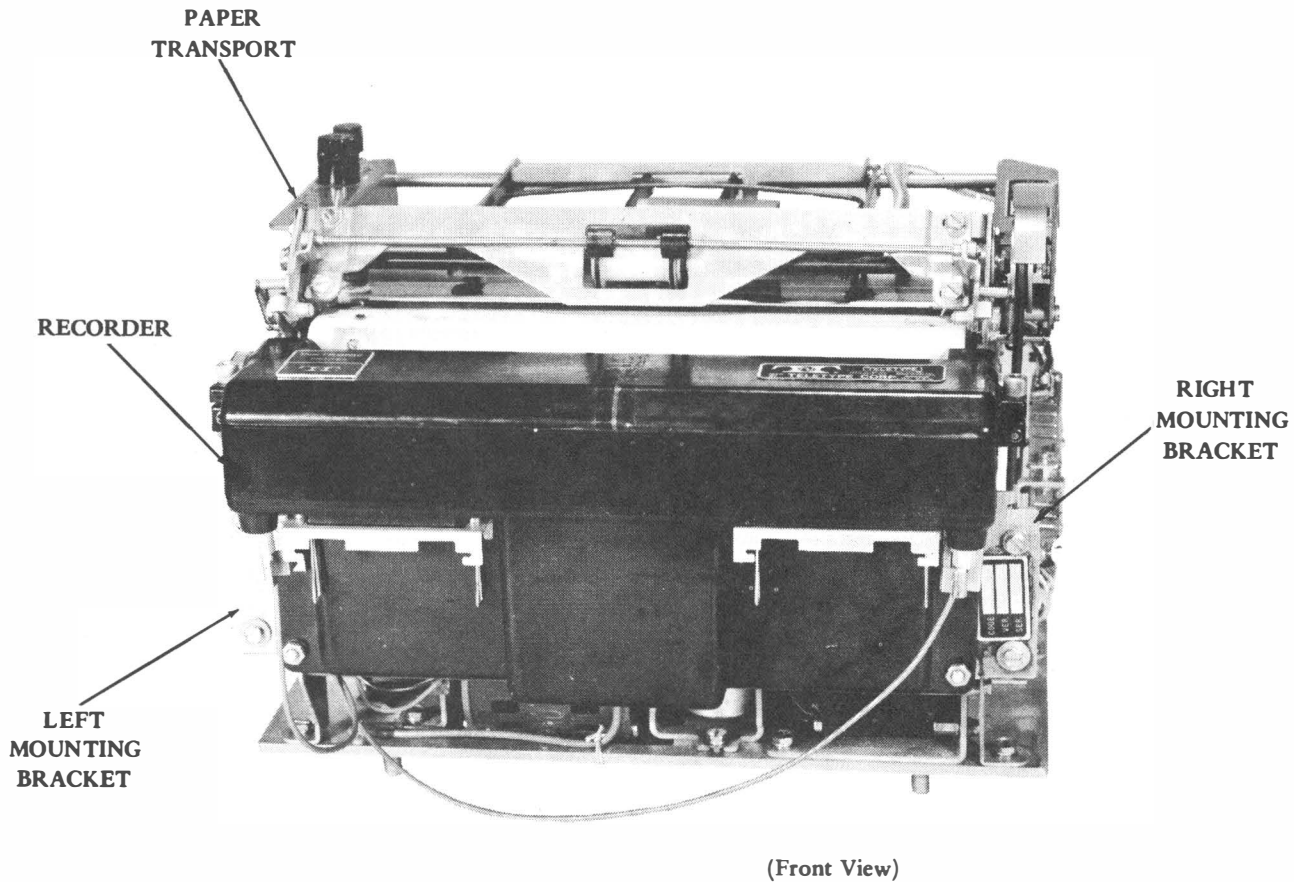

Figure 1 - Recorder/Paper Transport Assembly

2.03 To remove the tank cover, loosen the left and right thumb nuts securing the cover to the tank and pivot them down. While holding the tank firmly, lift and remove the tank cover.

2.04 No further disassembly of the recorder should be attempted in the field. The alignment of the electrodes is very critical, and the position of the manifold assembly should not be disturbed.

2.05 To Reassemble: Reverse the procedure used in disassembly. In mounting the recorder on the transport, insert the top screws in the mounting brackets before the bottom screws. Check the PLATEN-MANIFOLD CLEARANCE adjustment in Section 578-500-700 (formerly Section 592-820-700).

3. PAPER TRANSPORT

3.01 The transport consists of two main assemblies: The frame and the base. Most subassemblies can be removed from the frame without separating the frame from the base. However, the subassemblies on the base and on the underside of the frame are most easily reached by separating the frame from the base. This section describes the method of removing subassemblies from the frame, separating the frame from the base, and removing subassemblies from the underside of the frame and from the base, in that order.

3.02 Figure 2 shows the transport assembly with the recorder removed. The main subassemblies on the frame are labeled. If complete disassembly is not required, it is possible to gain limited access to the parts on the base and on the underside of the frame by simply removing the paper guideplate, which covers the lower part of the platen (3.04). For more complete disassembly, follow the procedures described on the following pages.

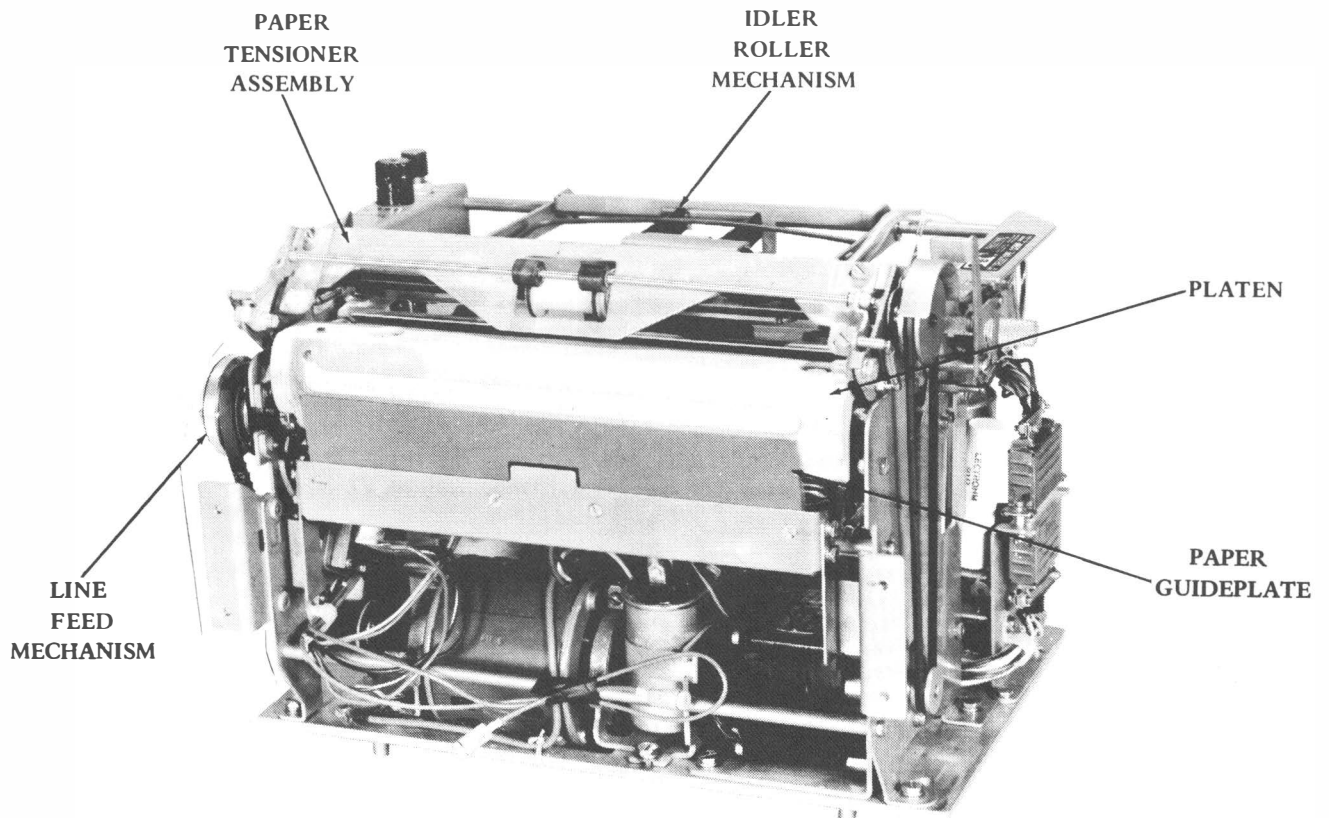

(Right Front View)

Figure 2 - Paper Transport Assembly

3.03 Paper Tensioner Mechanism

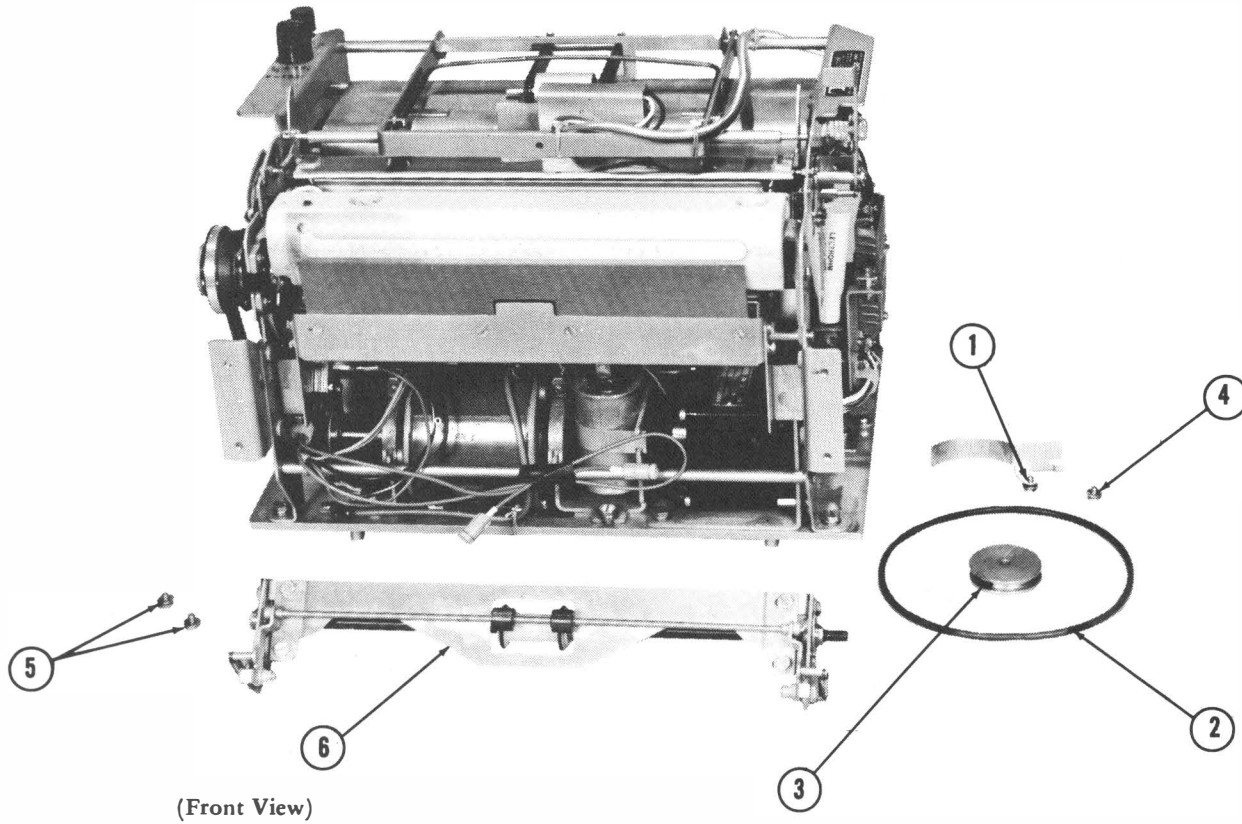

1. Remove the TP151630 screw, TP2191 lockwasher, TP7002 flat washer, and TP331055 bracket from the right side frame.
2. Remove the "O" ring belt.
3. Loosen the two setscrews and remove the TP330079 pulley.
4. Remove the TP151722 screw, TP2191 lockwasher, and TP7002 flat washer from the right side frame.
5. Remove the two TP151722 screws, TP2191 lockwashers, and TP7002 flat washers from the left side frame.
6. Remove the paper tensioner mechanism from the side frames.

To Reassemble: Reverse the procedure used in disassembly.

3.04 Platen and Paper Guideplate

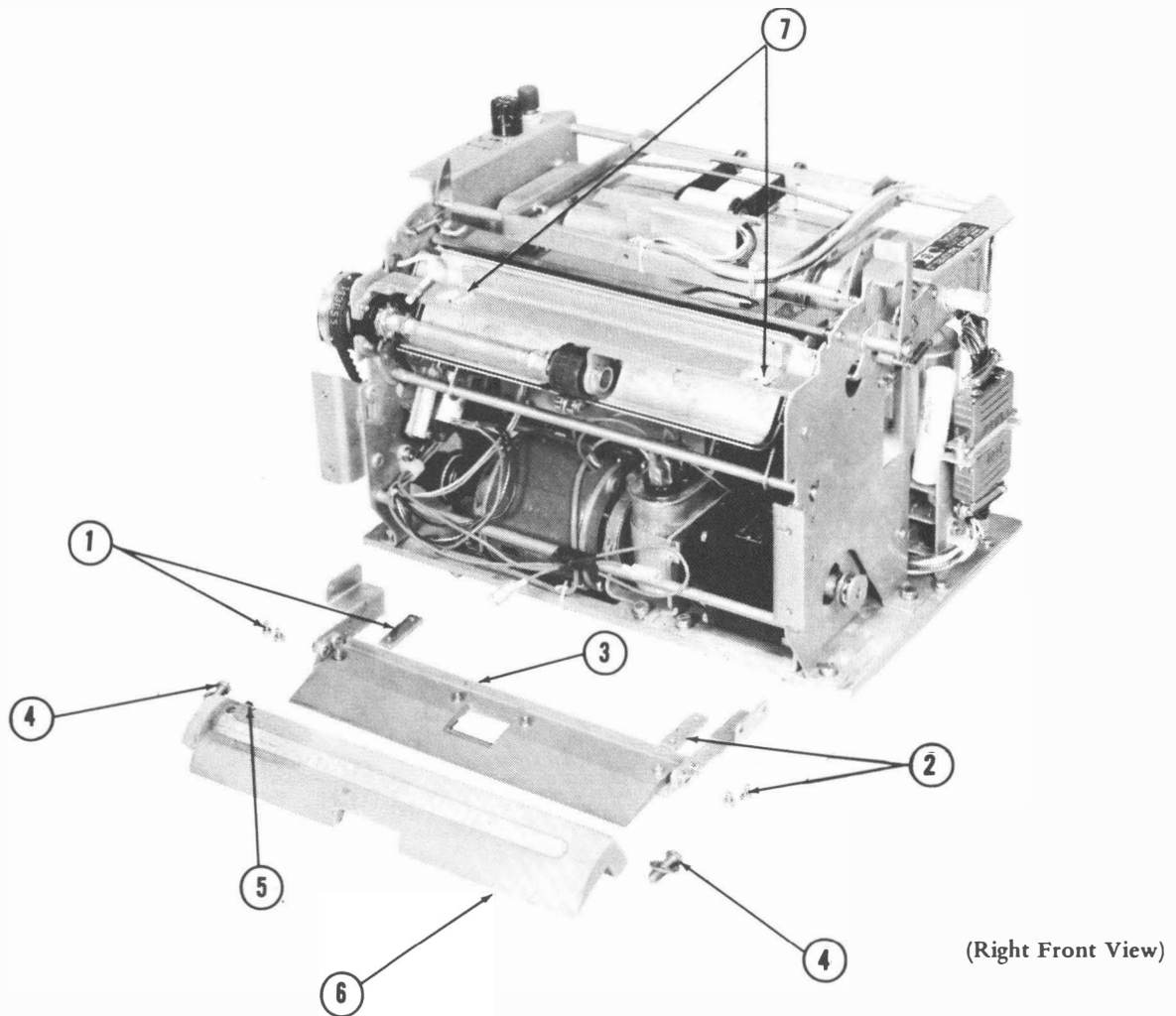

1. Remove the two TP152893 screws, TP110743 lock-washers, and TP125011 flat washers, and one TP331056 nut plate (inside left side frame).
2. Remove the two TP152893 screws, TP110743 lock-washers, and TP125011 flat washers, and one TP331056 nut plate (inside right side frame).
3. Remove the paper guideplate from the side frames.
4. Remove the two TP151724 screws and TP331168 flat washers from the top of the platen.
5. Loosen the setscrew at the top left of the platen and carefully withdraw the white high voltage lead from the left rear of the platen.
6. Remove the platen.
7. Retrieve the two TP331169 metal spacers on top of the line feed bracket.

To Reassemble: Reverse the procedure used in disassembly. Be sure to place the metal spacers on the line feed bracket in the positions shown in the photograph. Check the PAPER GUIDEPLATE adjustment in Section 578-500-700 (formerly Section 592-820-700).

3.05 Line Feed Mechanism

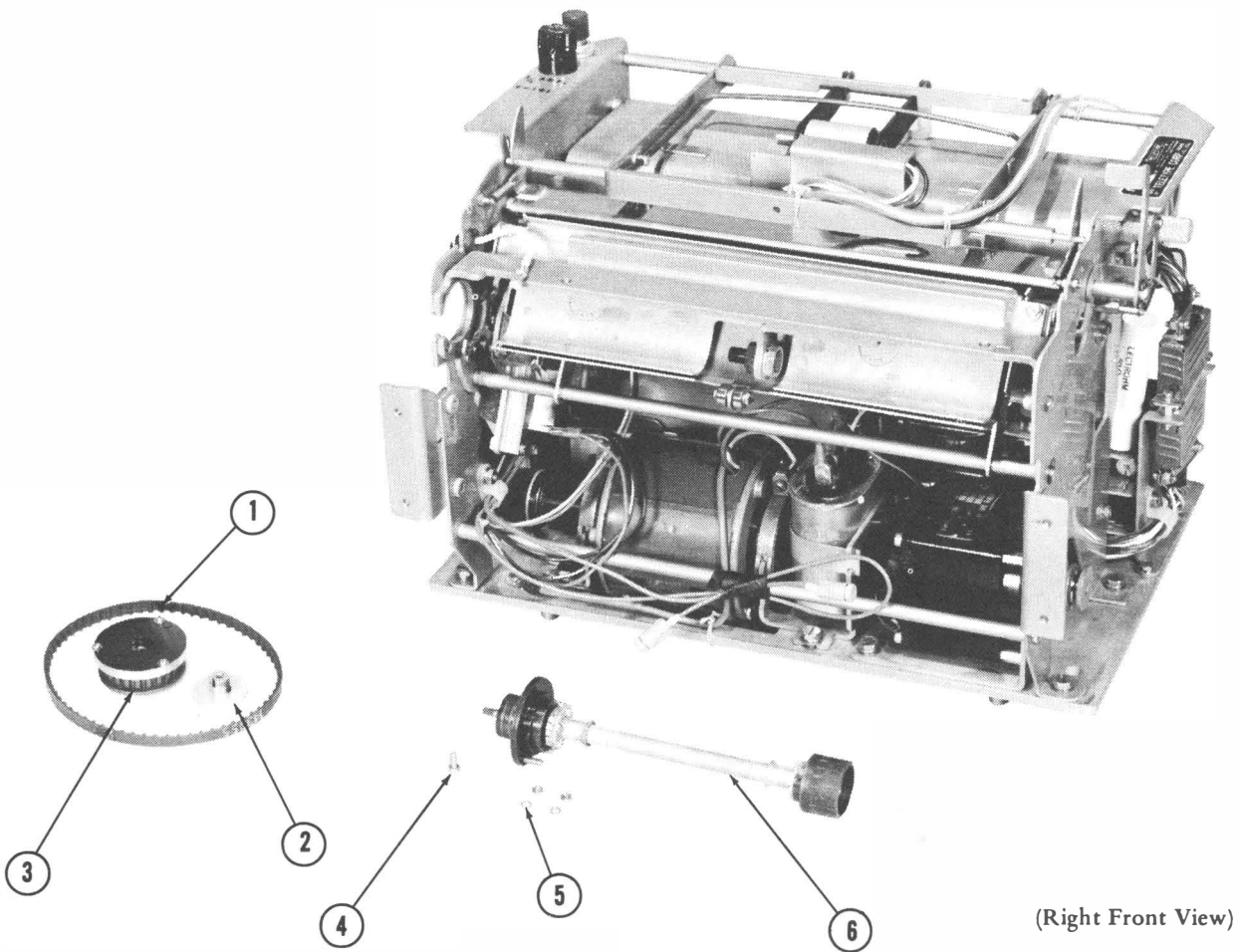

1. Remove the timing belt.
2. Loosen the two setscrews and remove the inertia disc from the line feed drive shaft.

Note: To gain access to the setscrews, manually shift the line feed escapement inside the left side frame while turning the inertia disc.
3. Remove the spiral spring housing from the line feed drive shaft.
4. Remove the TP151685 screw and TP110743 lock-washer, at the rear (flat) edge of the clutch assembly, from the left side frame.
5. Remove the two TP151880 nuts and TP110743 lock-washers (inside frame) from the two screws extending through the clutch assembly and left side frame.
6. Carefully slide the line feed assembly out of the left side frame. Make sure the magnet pawl does not catch on the assembly.

To Reassemble: Reverse the procedure used in disassembly. In reassembling the inertia disc, make sure the flat section of the spiral spring is seated in the slot on the inertia disc. Check the DRIVE PULLEY ENDPLAY, ESCAPEMENT PAWL CLEARANCE, and LINE FEED DRIVE BELT CLEARANCE adjustments in Section 578-500-700 (formerly Section 592-820-700).

3.06 Idler Roller Mechanism

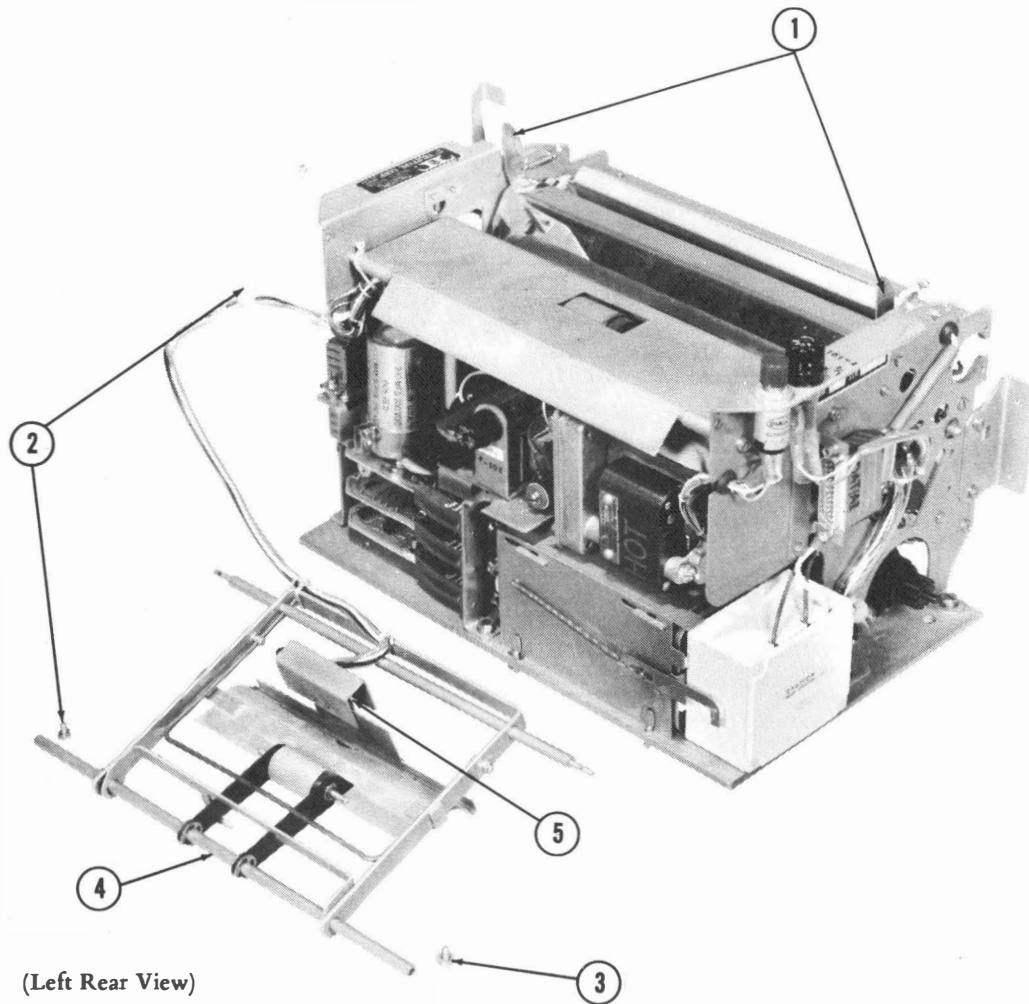

(Left Rear View)

1. Unlatch the front end of the idler roller mechanism by moving the latches on the paper guide to the rear.
2. Remove the TP151631 screw, TP2191 lockwasher, TP7002 flat washer, and TP121243 cable clamp from the top rear of the right side frame.
3. Remove the TP151631 screw, TP2191 lockwasher, and TP7002 flat washer from the top rear of the left side frame.
4. Remove the idler roller mechanism from the side frames.
5. To remove the loop forming switch, unscrew the two TP1178 screws, TP93117 lockwashers, and TP3624 flat washers, and slide the switch out of the switch shield. The leads must be unsoldered for replacement.

To Reassemble: Reverse the procedure used in disassembly.

3.07 Paper Guide Mechanism

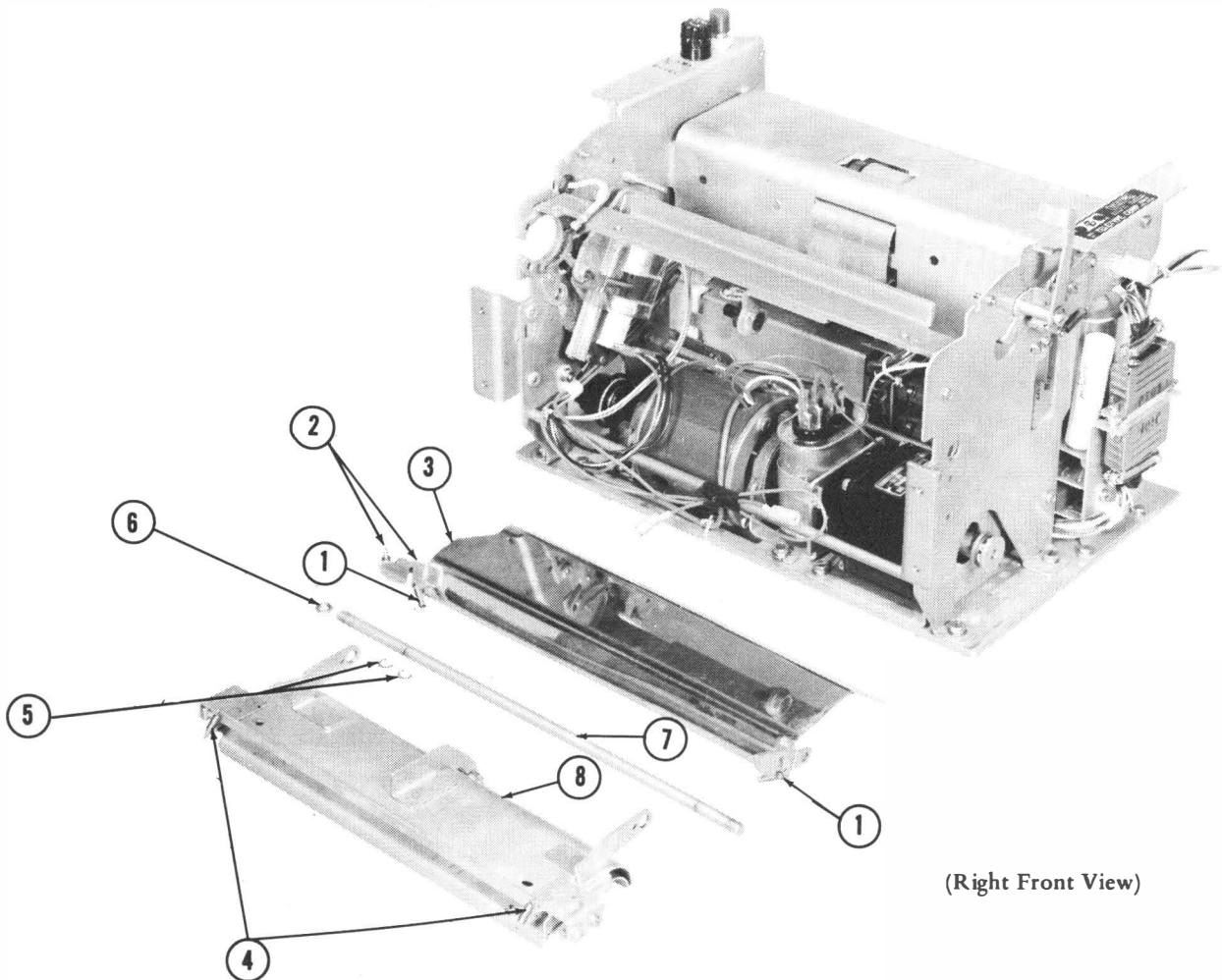

(Right Front View)

1. Remove the ends of the two TP49420 springs from the posts on the top front of the side frames.
2. Remove the TP152893 screw and TP110743 lockwasher (outside frame) and TP301052 bushing (inside frame) that hold the guide to the left side frame.
3. Remove the guide from the frame by raising its left end and sliding it to the left until it releases from the bushing on the right side frame.
4. Remove the ends of the two TP41382 springs from the posts on the side frames.
5. Remove the two TP119653 retainer rings from the notches in the guide shaft.
6. Remove the TP3603 nut from the threaded end of the shaft (outside left side frame).
7. Remove the shaft by unscrewing it from the left side frame and sliding it to the right, out of the right side frame.
8. Gently lift the paper guide assembly out of the frame, being careful not to scratch or bend any of the parts.

To Reassemble: Reverse the procedure used in disassembly. Be especially careful in placing the guide assembly into the frame assembly to avoid bending or scratching any parts. Check the PAPER THROAT and PAPER FEED GUIDE adjustments in Section 578-500-700 (formerly Section 592-820-700).

3.08 Separating the Frame From the Base

The frame can be separated from the base to provide full access to the components on the base end underside of the frame. The recorder **MUST** be removed from the paper transport before attempting this operation. To simply raise the frame from the base, proceed as shown below. To completely remove the frame, continue the procedure as shown in 3.09.

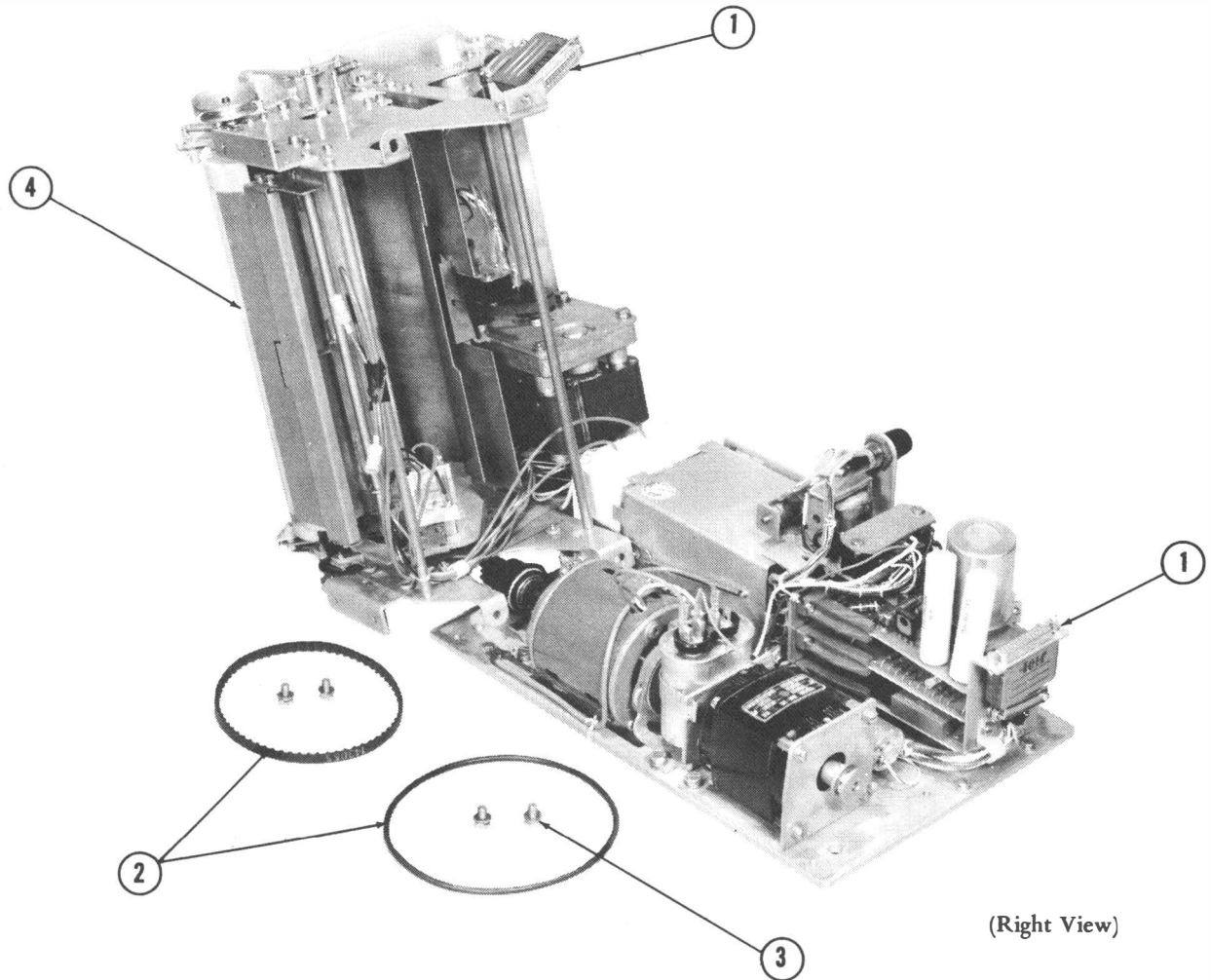

1. Separate connectors P101 and J101 on the right side of the transport.
2. Remove the "O" ring belt and the timing belt from the right and left sides of the transport.
3. Remove the four TP151723 screws, TP2669 lockwashers, and TP117535 flat washers that hold the legs of the frame to the base.

- Note:** If complete removal is desired, omit Step 4 and go to Step 5 (3.09).
4. Carefully raise the right end of the frame and pivot it upward. Prop the frame securely on its left side. Make sure there is no undue pressure on any of the cables or connecting leads.

3.09 Separating the Frame From the Base (continued)

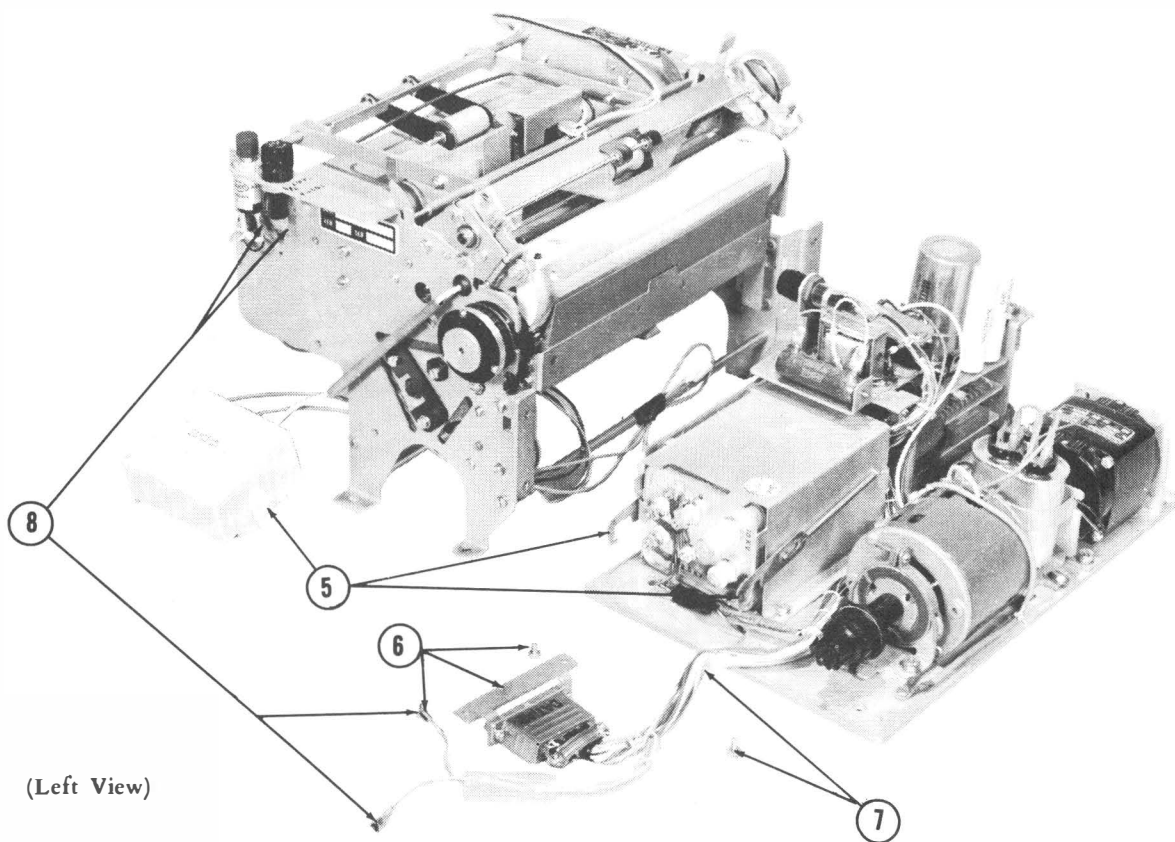

5. After completing Steps 1 through 3 (3.08), remove the high voltage cover assembly by raising the spring latches on both sides of the power supply bracket and sliding the cover to the left.
6. Remove the two TP151630 screws, TP2191 lockwashers, and TP7002 flat washers that hold the DAT/A1 connector bracket to the left side frame.
7. Remove the TP151630 screw, TP2191 lockwasher, and TP7002 flat washer that hold the cable clamp to the left side frame.
8. Slide the plastic sleeve down from the fuse holder on the top of the left side frame, and carefully pull the two wire connectors off the fuse terminals.
9. Lift the transport frame directly upward, away from the base. Make sure the legs of the transport do not catch on any of the base components.

To Reassemble: Reverse the procedure used in disassembly. Be sure to dress the cables properly to avoid crimping them when the frame is placed back on the base. Also, make sure the leads are in the notch on the high voltage cover before latching the cover to the power supply bracket.

3.10 Line Feed Magnet Assembly and Pre-Paper Puller Mechanism

The line feed magnet assembly and pre-paper puller mechanism are mounted on the underside of the transport frame. Although the magnet assembly is accessible from the front of the transport if the paper guideplate is removed from the lower part of the platen, it is more convenient to remove the magnet assembly if the frame is separated from the base. The pre-paper puller mechanism is accessible only when the frame and base are separated. Figure 3 shows the magnet assembly and pre-paper puller mechanism as viewed from the rear with the transport frame inverted.

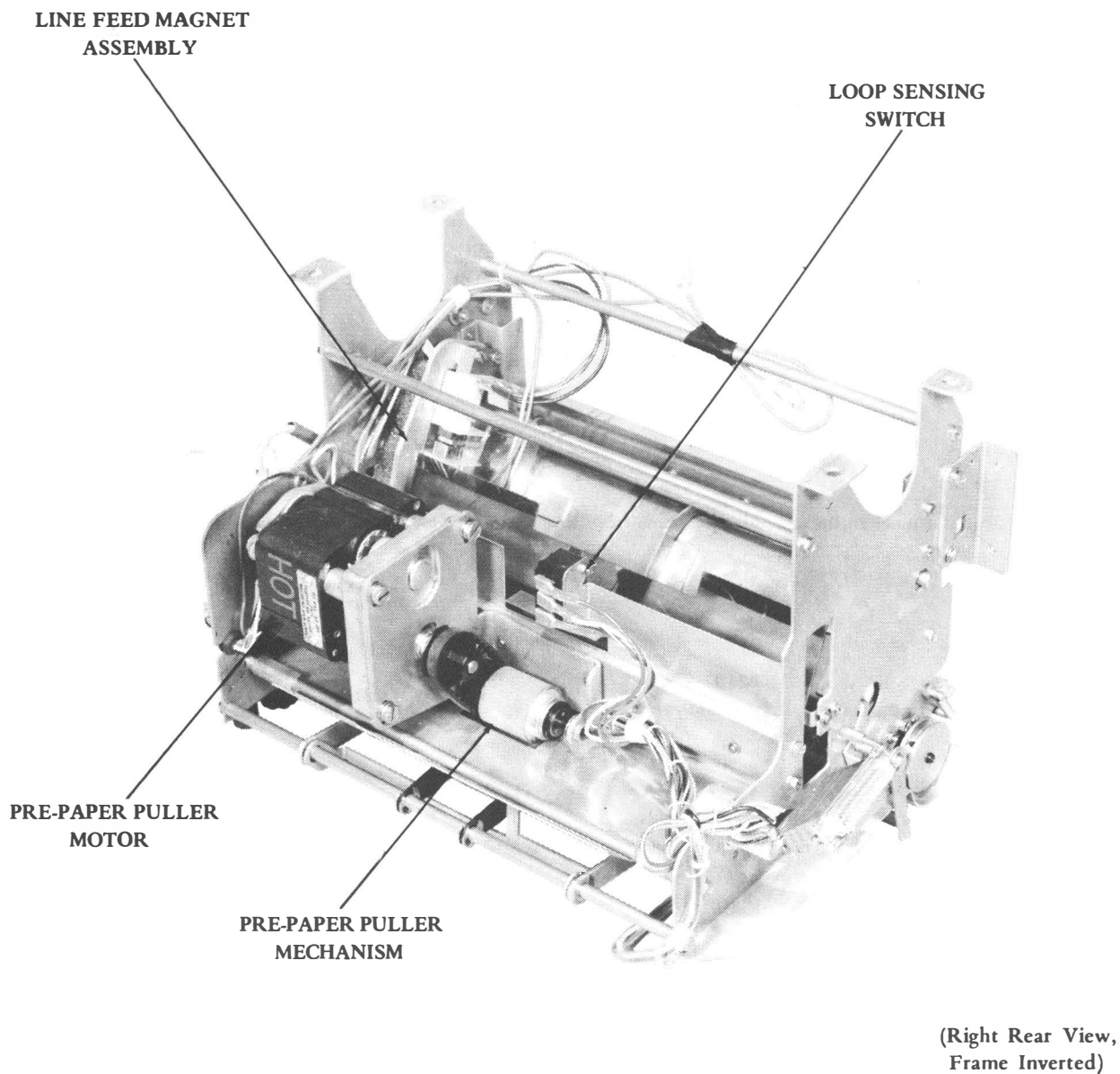

(Right Rear View,
Frame Inverted)

Figure 3 - Underside of Paper Transport Frame

3.11 Line Feed Magnet Assembly and Pre-Paper Puller Mechanism (continued)

To remove the magnet assembly, first remove the plastic cover (TP330474) and unsolder the leads from the terminals of the coils. Then proceed as follows:

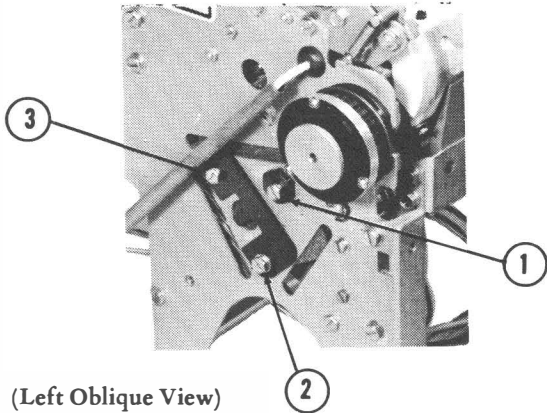

(Left Oblique View)

1. Remove the TP151631 screw, TP2191 lockwasher, and TP330254 eccentric bushing from the left side frame.
2. Remove the TP151631 screw, TP2191 lockwasher, and TP7002 flat washer from the left side frame.
3. While holding the magnet assembly inside the frame, remove the TP151631 screw, TP2191 lockwasher, and TP301227 plate from the left side frame. The magnet assembly and its pad (TP310507) can now be removed from the inside of the left side frame.

To Reassemble: Reverse the procedure used in disassembly. Check the ESCAPEMENT PAWL CLEARANCE, and with the transport completely reassembled and in operation, check the ESCAPEMENT ECCENTRIC adjustment in Section 578-500-700 (formerly Section 592-820-700).

To remove the pre-paper puller mechanism, unsolder the leads from the motor terminals and proceed as follows:

1. Remove the two TP151630 screws, TP2191 lockwashers, and TP7002 flat washers that hold the mounting bracket to the tie bar. The complete pre-paper puller mechanism can now be removed from the frame.
2. To remove the loop sensing switch, unplug the leads from the switch terminals, then remove the two TP151689 screws, TP110743 lockwashers, TP125011 flat washers and TP151880 nuts that hold the switch to the guide pan.

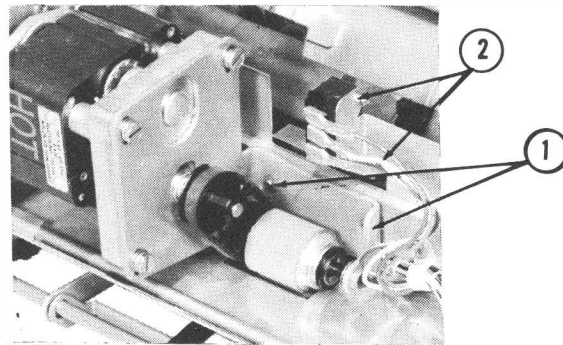

(Right Rear View,
Frame Inverted)

To Reassemble: Reverse the procedure used in disassembly. Check the PRE-PAPER PULLER DRIVE BELT adjustment in Section 578-500-700 (formerly Section 592-820-700).

- 3.12 With the frame removed from the base, all parts on the base are readily accessible. Figure 4 shows the base as viewed from above, with the front of the base in the foreground.

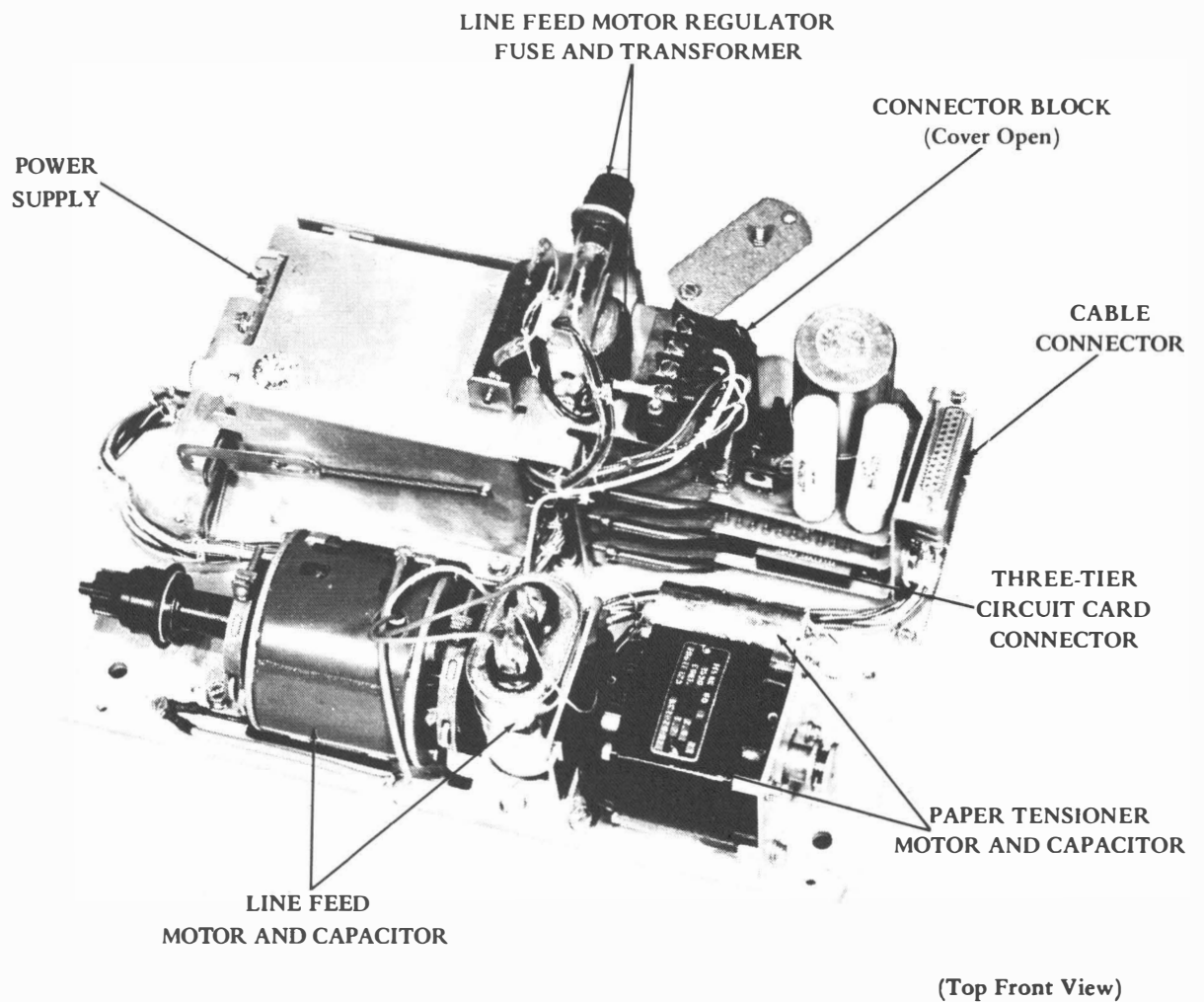
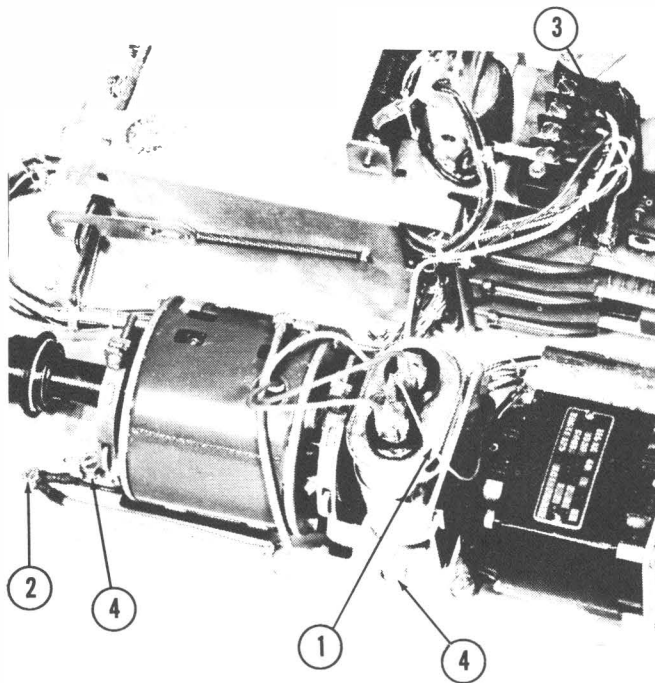

Figure 4 - Paper Transport Base Assembly

3.13 Line Feed Motor and Capacitor



(Top Front View)

1. Unplug the blue cable lead from the capacitor terminal.
2. Loosen the ground screw and slide the spade lug of the green motor lead out from under the star washer.
3. Remove the yellow motor lead from terminal 3 of the connector block at the rear of the base.
4. Remove the four TP153441 screws, TP2669 lock-washers, and TP117535 flat washers, and lift the motor and capacitor bracket off the base.

To Reassemble: Reverse the procedure used in disassembly.

3.14 Paper Tensioner Motor and Capacitor

1. Remove the blue motor lead from terminal 3 of the connector block at the rear of the base.
2. Unsolder the white/blue cable lead from the capacitor terminal.
3. Remove the three TP151723 screws, TP2669 lock-washers, and TP117535 flat washers, and lift the motor and capacitor bracket off the base.

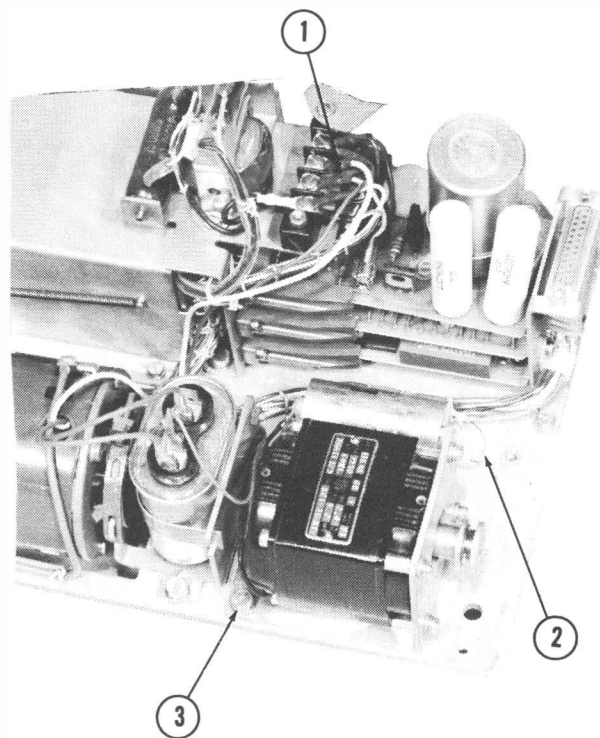

(Top Front View)

To Reassemble: Reverse the procedure used in disassembly.

3.15 Power Supply

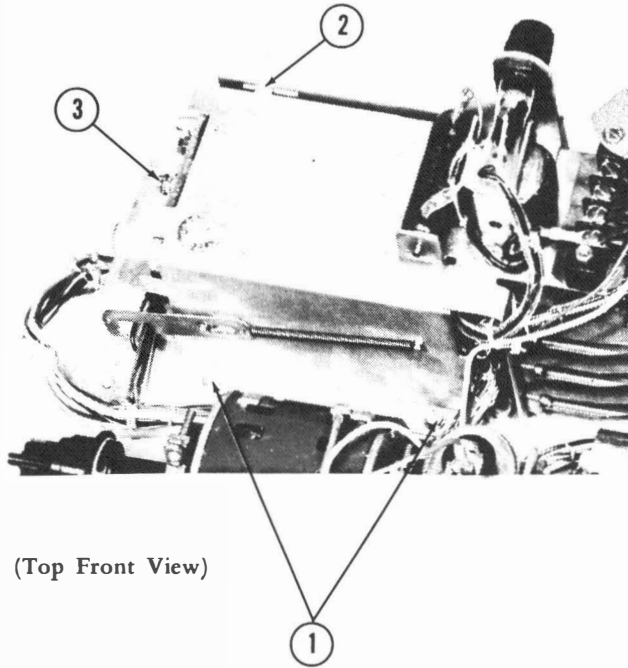

(Top Front View)

1. With the high voltage cover separated from the power supply bracket (Step 5 of 3.09), remove the two TP151632 screws, TP2191 lockwashers, and TP7002 flat washers from the front section of the power supply bracket.
2. Disengage the tabs on the front section from the slots on the rear section of the bracket.
3. Remove the nuts on the power supply terminals and remove the leads from the terminals. The sealed supply can now be lifted off the base.

To Reassemble: Reverse the procedure used in disassembly.

