

*PAPER 578-500-200  
PAGE 18*

“DATASPEED®” PRINTER

RECEIVE-ONLY STATION

GENERAL DESCRIPTION AND OPERATION

	CONTENTS	PAGE
1.	GENERAL . . . . .	1
	STATION ADAPTERS . . . . .	5
2.	COMPONENTS . . . . .	5
3.	PHYSICAL CHARACTERISTICS . . . . .	16
4.	OPERATION . . . . .	17
	MANUAL OPERATION . . . . .	17
	RECEIVE-ONLY STATION WITH DISCRETE CALLING ACCESSORY . . . . .	17
	UNATTENDED OPERATION . . . . .	17
	DISCONNECT PROCEDURES . . . . .	17

1. GENERAL

1.01 This section provides the general description and operational information for the DATASPEED Printer Receive-Only Station, a high-speed, nonimpact type recorder that directs ink droplets (character by character) to form its printed output. It is being reissued to incorporate recent engineering changes. Since this is a general revision, marginal arrows ordinarily used to indicate changes and additions are omitted. This section was formerly designated 592-820-100, but this number is now cancelled. Since this issue of Section 578-500-100 is a revision of Section 592-820-100, Issue 2, it is designated Issue 3.

1.02 The receive-only printer (Figures 1 and 2) is intended for service with either serial or parallel data input. For serial input, a 202C or 202D data set is mounted in the printer, or a modification kit is installed to permit operation with Type 2 DATASPEED equipment. For parallel input, a 402D data set (with or without an 804A data auxiliary set) is connected to the printer, or a modification kit is installed to permit operation with Type 5 DATASPEED equipment. Optional features include a discrete calling generator, which provides unattended service, and an automatic paper winder to take up the printed paper.

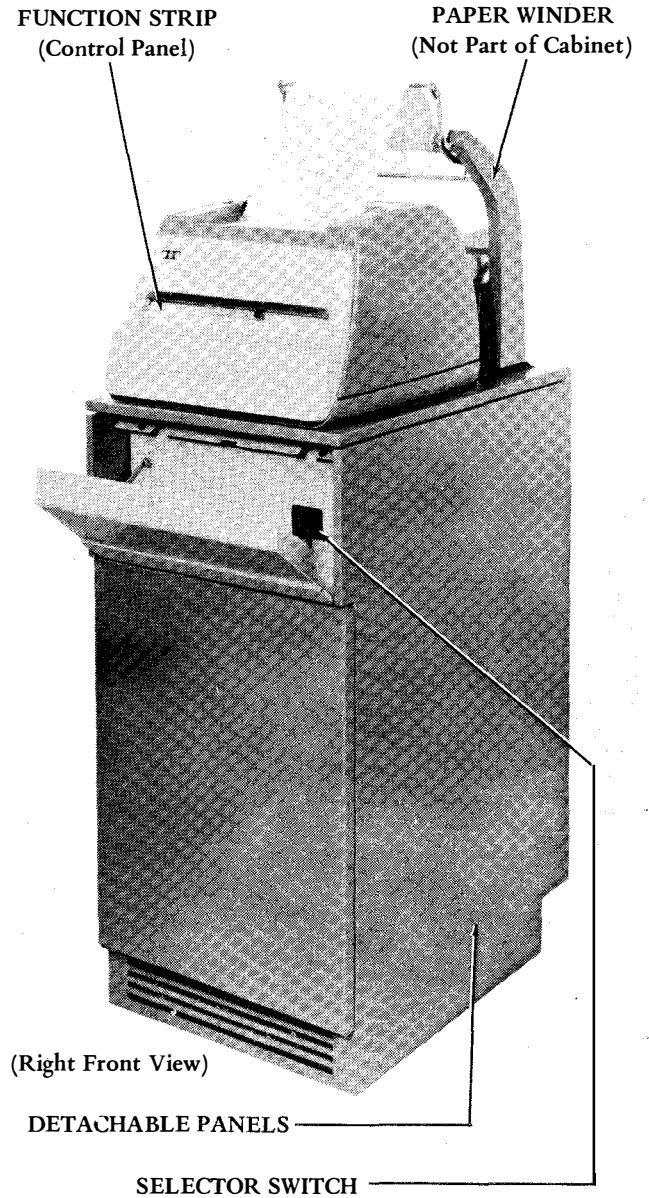

Figure 1 - DATASPEED Printer Receive-Only With Paper Winder

*for Component Page  
1 Q TO 15*

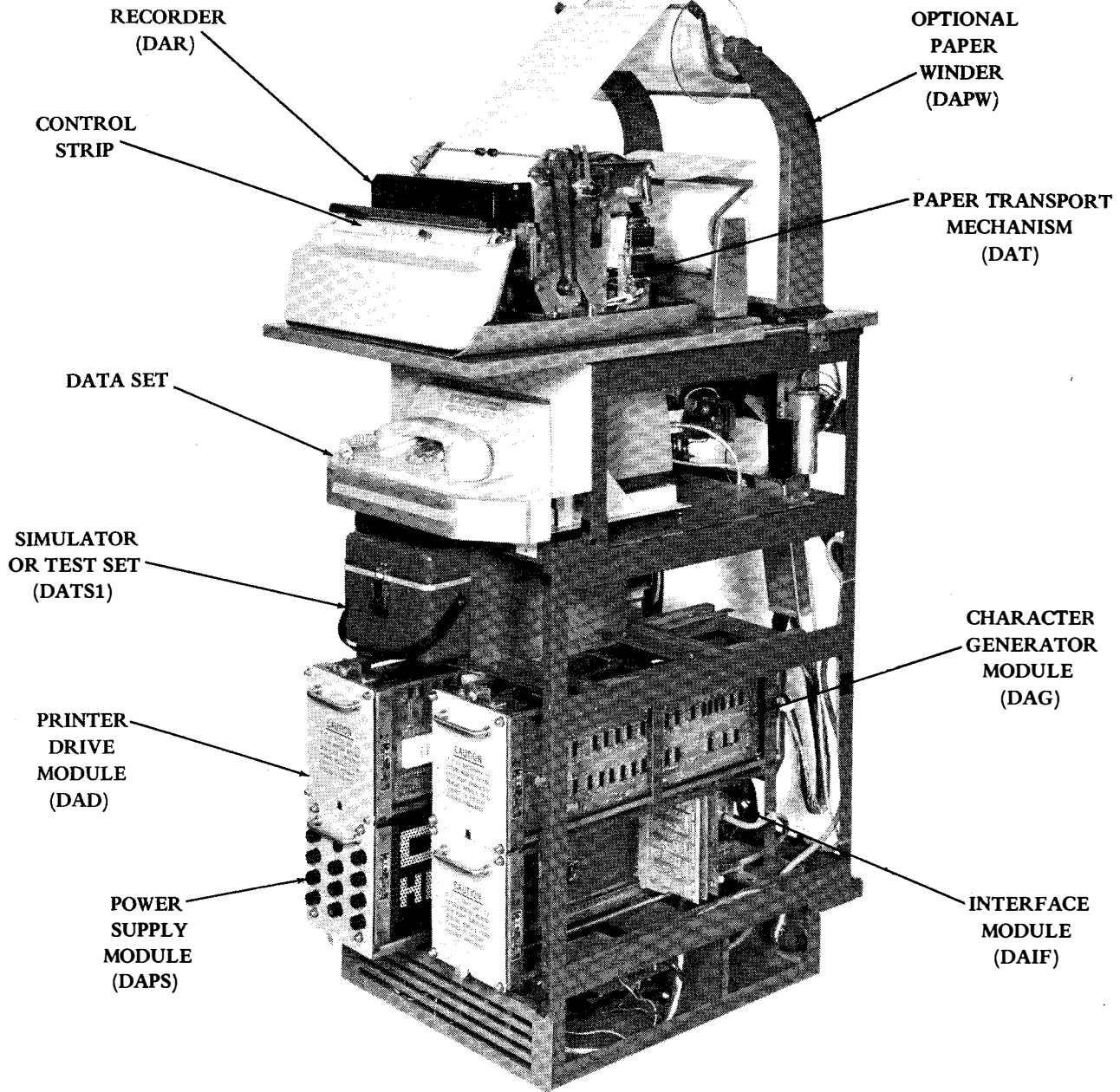

Figure 2 - DATASPEED Printer With Modular Assemblies Extended

1.03 In the DATASPEED system of forming characters, charged ink droplets are drawn from a series of nozzles and accelerated toward the platen of the printer. The droplets are electrostatically deflected to trace out the shape of the character on conventional teletypewriter paper, which is stepped across the electrically charged platen. Refer to Section 578-500-110 (formerly Section 592-820-110) for further description of the recorder and paper transport mechanism.

1.04 The basic character-forming element consists of a recorder (ink tank, nozzles, and deflection electrodes) and paper transport mechanism (a high-speed paper-stepping mechanism for line feeding) enclosed by a protective cover at the top of the cabinet. These units are driven by associated modules and assemblies contained in the cabinet (Figure 2).

1.05 The control strip is mounted on the lower front section of the cover assembly. An interlock system de-energizes the high voltage power supply when the cover lid or the cabinet doors are opened. A paper jam/paper out alarm circuit is associated with the interlock string to turn off the printer and give a visual alarm if the paper does not feed properly.

**CAUTION: DE-ENERGIZE SET BEFORE ATTEMPTING ANY INSPECTION OR TESTS. ONLY QUALIFIED PERSONNEL SHOULD ATTEMPT TO OVERRIDE THE SAFETY INTERLOCK SYSTEM.**

1.06 The DATASPEED printer is capable of receiving and printing characters at speeds up to 120 characters per second or 1200 words per minute. It will print up to 63 upper case letters and symbols on an 80-character line using Baudot (5-level) code or ASCII (United States of America Standard Code for Information Interchange) as the input intelligence. Horizontal spacing of 10 characters per inch and vertical spacing of 6 lines per inch are provided.

1.07 The incoming digital signals are received by the interface module and routed to the associated modules for conversion to signals that vary the charges on the valving and deflection electrodes of the recorder. The valving signals select the desired character positions (columns) on the line, and the deflection signals trace the shapes of the characters. Characters are formed by a pattern of ink dots in a matrix with a center-to-center spacing of approximately 0.10 inch. This provides a character size of approximately 0.080 by 0.100 inch.

1.08 The only moving part, excluding the paper feed mechanism, is the ink pump submerged in the ink tank of the recorder. Thus, the printer operates at high speed with very little noise. The capacity of the ink tank is adequate for approximately 1200 hours of operation at 1200 wpm. The recorder assembly includes the ink tank (which also serves as a case for the assembly), the pump, a manifold

assembly, and a nozzle and electrode assembly (Figure 8). The case is sealed by a tight-fitting cover, and the recorder is mounted in line with the platen on the transport mechanism. A thermostatically-controlled heater maintains the ink at a temperature that ensures good printing. A cavity in the manifold is continuously filled by a flow of ink pumped from the tank, with the surplus draining back to the tank. The nozzles are attached to the ink cavity at a level that will maintain a slight hydrostatic pressure on all of the nozzles. The valving voltage applied to a given nozzle causes ink to flow from the nozzle when printing is to occur at a given position on the line.

**CAUTION: AVOID SPILLING INK OR COMING IN CONTACT WITH THE INK RESIDUE AROUND THE ELECTRODE ASSEMBLY. THIS INK HAS POWERFUL STAINING PROPERTIES AND TRANSFERS READILY TO OTHER MATERIALS.**

1.09 The valving electrodes are energized sequentially, from left to right, by applying valving voltage (+550 v) to the nozzle at the desired character position. Each nozzle assembly prints two characters; that is, the ink stream from one nozzle prints a left character, then crosses over to print the next character to its right.

1.10 Figure 3 shows a typical electrode assembly. There are 40 of these assemblies located side by side on the recording head (Figure 8), each providing two character positions or columns to produce an 80-character line. With the valving electrode energized, the ink droplets are drawn from the nozzle and pass through the hole in the valving electrode. A basic tracing pattern is arranged by the circuit logic for each character (Figure 4). Because the ink stream is returned to its approximate starting point when printing the last dot of the character, no trailing line is produced. The vertical and horizontal deflection electrodes direct the droplets to the various dot positions of the character matrix. The positively charged platen attracts the deflected ink droplets so that they strike the paper, which is stepped across the face of the platen.

1.11 The control switches on the enclosure are interconnected with the modules, interlock and alarm circuits of the supporting cabinet. As mentioned, the character-forming process depends upon associated modules and mechanisms for the drive signals, control signals, and paper supply regulation. Most of the circuit logic is housed in separate modules that are latched together inside the cabinet. A clamping arrangement secures the modules during shipment. With the clamp released, the modules may be extended to facilitate servicing.

**CAUTION: NEVER EXTEND ALL MODULES TO THEIR EXTREME FORWARD POSITION WITHOUT SOME SUPPORT UNDER THE FRONT END OF THE LOWER MODULES.**

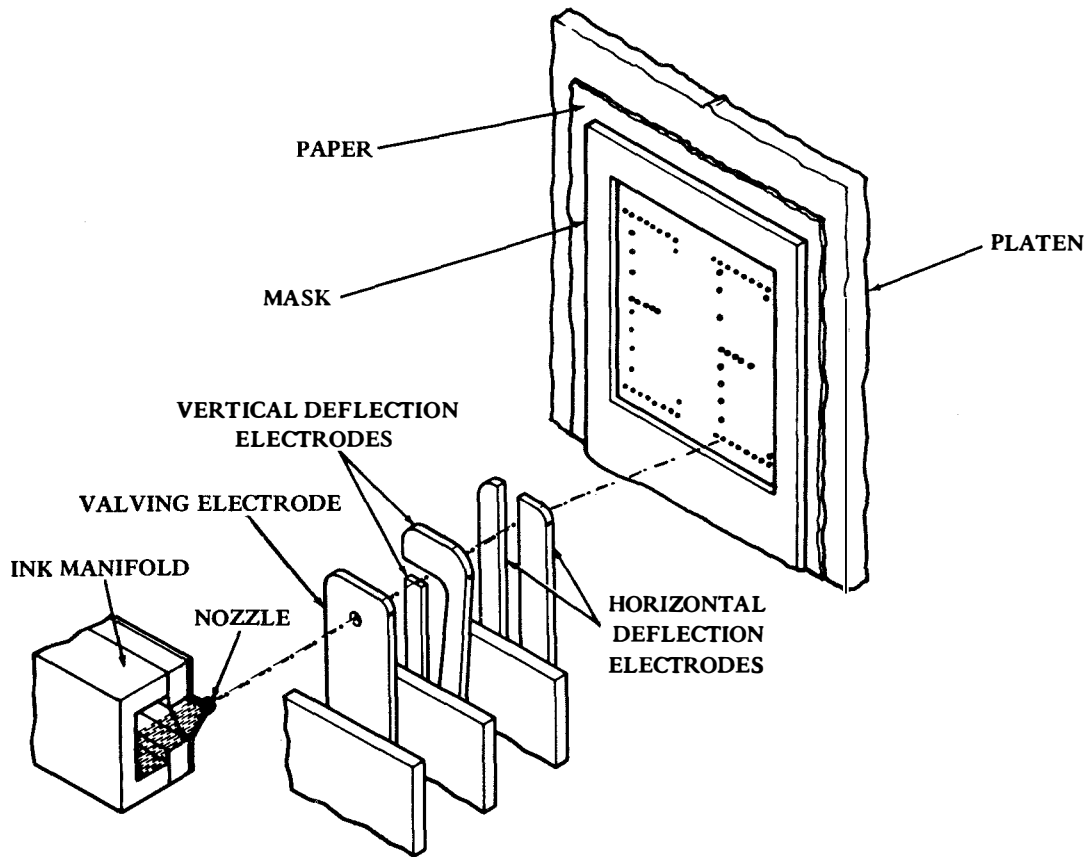

Figure 3 - Ink Manifold, Modulating Electrodes, and Mask Assembly

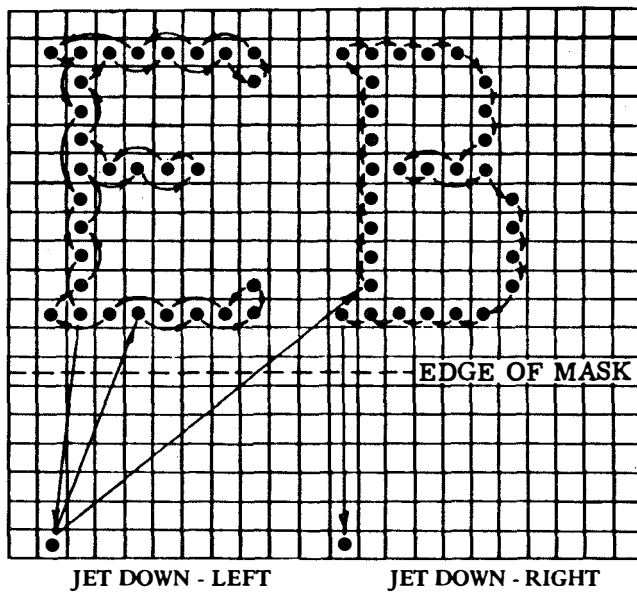

Figure 4 - Basic Tracing Pattern of Typical Electrode Assembly

1.12 The printed copy is formed on conventional 8-1/2 inch teletypewriter paper on a single copy basis only. Multiple copies may be reproduced from the original copy by a conventional letter copier.

1.13 Line feed and/or carriage return operations are allowed an additional half-character time (12 milliseconds compared to the 8-millisecond interval for each character at 1200 wpm). On the 81st character (printing or spacing), with the exception of carriage return, an automatic carriage return/line feed operation is initiated internally. The 81st character will not print. Moreover, the 82nd character will be distorted at speeds over 500 wpm.

1.14 The cabinet supports a paper unwinder assembly for a 5-inch roll of paper. This is a basic part of the printer assembly. The paper winder, an optional feature, is ordered separately.

1.15 Data sets are used as follows:

<u>INPUT</u>	<u>DATA SET</u>
Serial	202C or equivalent 202D or equivalent
Parallel	402D* or equivalent 804A data auxiliary set or equivalent

\*The 402D data set must be mounted outside the cabinet.

1.16 The input/output characteristics for the services indicated in Figure 5 are as follows:

SERIAL OPERATION

(Type 2 DATASPEED Service)

Data Input: 5- to 8-level code in 10-unit frame.

Maximum Data Rate: 1200 baud; 120 characters per second.

Control Inputs: Data Set Ready, Data Carrier Detect, Clear to Send, and Ring Indicator (with 202C data set only).

Control Outputs: Data Terminal Ready, Supervisory Channel Send, Request to Send.

Input and Output Voltages and Impedances: In accordance with EIA-RS232B.

PARALLEL OPERATION

(Type 5 DATASPEED Service)

Data Input: Up to 8-level code, and character available.

Maximum Data Rate: 750 baud; 75 characters per second.

Control Inputs: Interlock, Carrier On, and Ring Indicator (when 804A data auxiliary set is used with a 402D data set).

Control Outputs: Data Receive, Answer-Back A, Answer-Back B, Reverse Channel Send, Remote Release, Remote Operate.

Input and Output Voltages and Impedances: As required by the 402D data set.

STATION ADAPTERS

1.17 The station adapters are electrical and mechanical assemblies used to interconnect the printer terminal with existing tape terminal equipment to form various station arrangements. These adapters include the interconnecting cables, selector switch, and hardware for the station arrangements. In these station arrangements, the terminals are located adjacent to one another.

1.18 For the receive-only application, there are six station adapter groups. Three of the adapter groups (serial operation) interconnect the printer with Type 2 DATASPEED equipment in the following manner: (a) Monitors the tape sender terminal; (b) monitors the tape receiver terminal, and (c) monitors the tape send/receive terminal (Figure 5). In a similar manner, Type 5 DATASPEED equipment (parallel operation) is interconnected with the printer with the three terminal applications listed above.

1.19 In an arrangement with the receive-only DATASPEED printer used in conjunction with a Type 2 or 5 DATASPEED tape terminal, the entire station is under the control of the DATASPEED tape terminal. The printer acts as a "slave unit" to monitor either the outgoing or incoming intelligence. Calls can be initiated and terminated in accordance with the established tape terminal procedures.

1.20 The printer should be connected to a signal source; a data "modem" or dc line. The 117 volt ac power should be applied for a minimum of 15 minutes before copy is desired. This allows the ink to warm up to operating temperature. All cabinet doors and covers should be closed and paper threaded through the transport mechanism in order to complete the interlock and alarm circuit.

2. COMPONENTS

2.01 A terminal is made up of discrete modular assemblies as shown in Figures 8 through 14. Provisions have been made in the design of the unit for addition of features or modifications that may be needed for future station requirements. The cover and base assembly encloses the electrostatic ink dispensing mechanism. Note the location of the interlock switches and the jumper plug arranged to override the safety feature for service only (Figure 6). The major control and operating pushbutton switches are located at a convenient height on the cover assembly. The controls and their basic functions are identified in Figure 7. The copyright assembly is located at the rear of the control buttons.

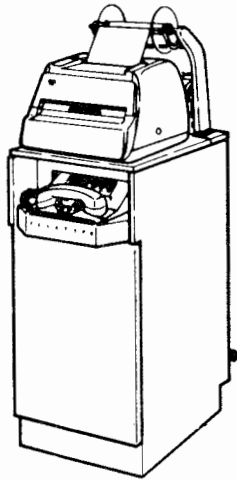

WITH DATA SET  
SHELF ASSEMBLY  
FOR 202C DATA SET  
OR 804A DATA  
AUXILIARY SET

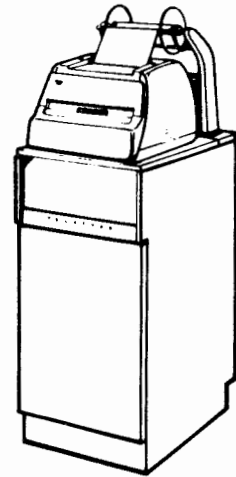

WITH BLANK FRONT  
PANEL FOR 202D OR  
402D DATA SET



DIRECT INTERFACE  
WITH "DATASPEED"  
RECEIVER

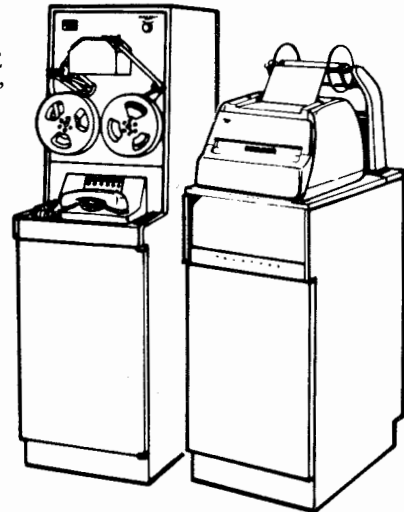

DIRECT INTERFACE  
WITH "DATASPEED"  
SENDER

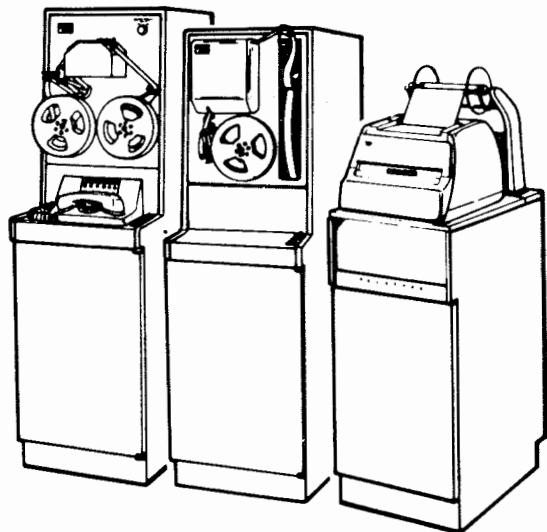

DIRECT INTERFACE WITH "DATASPEED" SENDER AND RECEIVER

Figure 5 - Typical Printer Applications - Monitoring High Speed Data

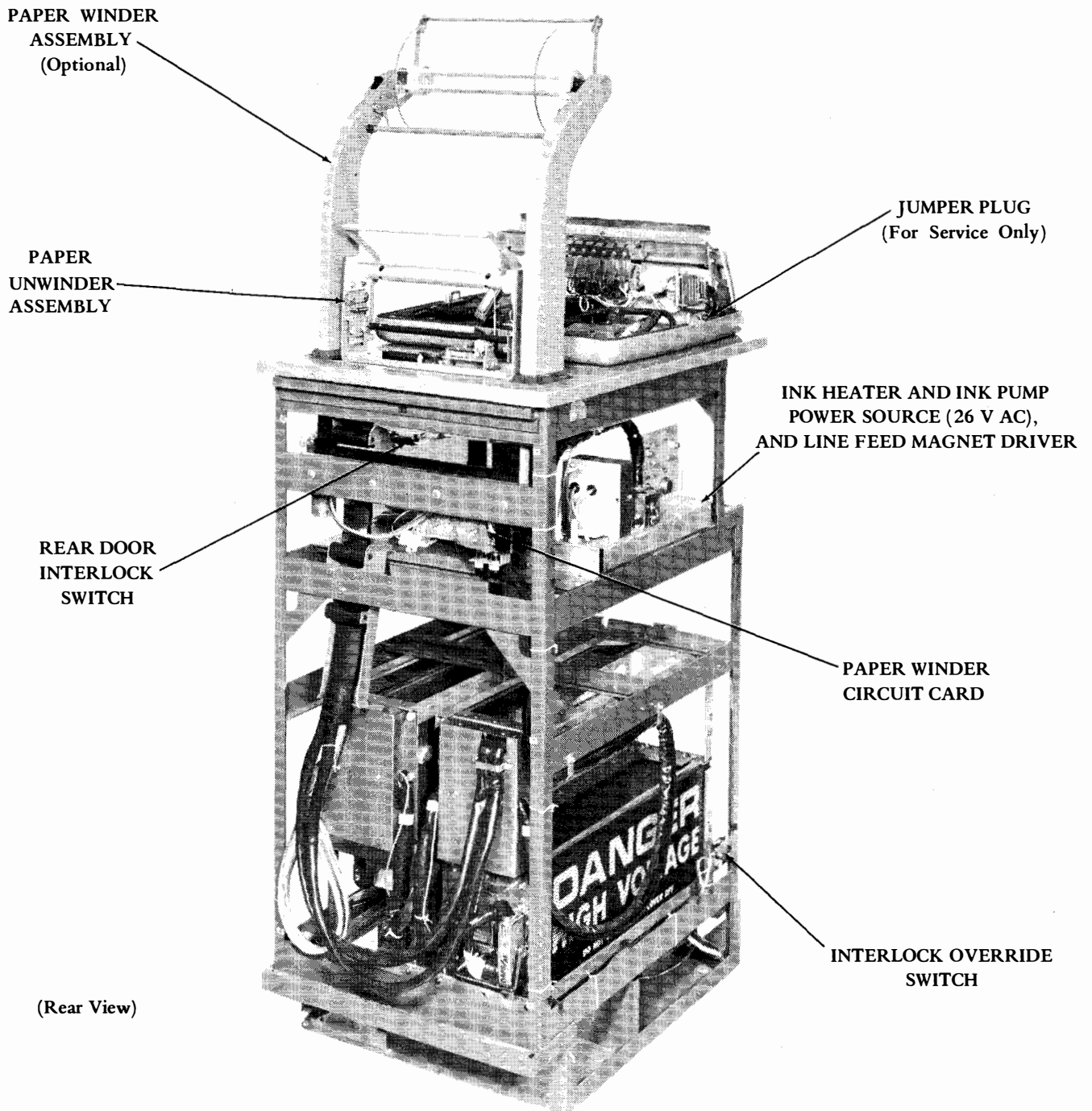

Figure 6 - Cabinet Assembly Less Removable Panels and Doors

**BREAK LAMP AND KEY:** When key is depressed supervisory channel signal is interrupted. Lamp remains on and signal is interrupted until key is released (see note).

**TRANSMIT START LAMP AND KEY:** With key depressed, discrete calling generator is activated. Lamp remains on until generator completes its cycle. With no generator option present, lamp lights when depressed, but no action takes place (see note).

**PRINTER ON LAMP AND KEY:** When printer motors and high voltage supply are turned on, this lamp lights. If lamp lights when key is depressed, all interlocks are closed and paper supply is adequate. If lamp does not light, check interlocks and paper alarm circuits.

**LOW PAPER ALARM LAMP AND KEY:** When a low paper condition exists, as monitored by the paper unwinder, this lamp (red) lights (see note). Depressing key causes W test characters to be generated repeatedly (late design units only).

**PAPER ADVANCE LAMP AND KEY:** Depressing this key initiates a repetitive line feed action. Paper feed function is set for 15 lines/sec; faster rates may be selected. Lamp remains lit while key is held (see note).

**READY LAMP AND KEY:** When ready lamp is on, the interlock and alarm string (all interlocks, paper-out alarm, and overvoltage circuit) are in their ready state. Printer should then be capable of turning on and receiving messages, allowing for a 15-minute warmup time. Depressing key resets overvoltage monitoring circuits (see note).



**Note:** This is a nonlatching, nonexcluding type key (push-button) assembly.

Figure 7 - Operating Controls on Front Panel of Recorder/Transport Base Assembly



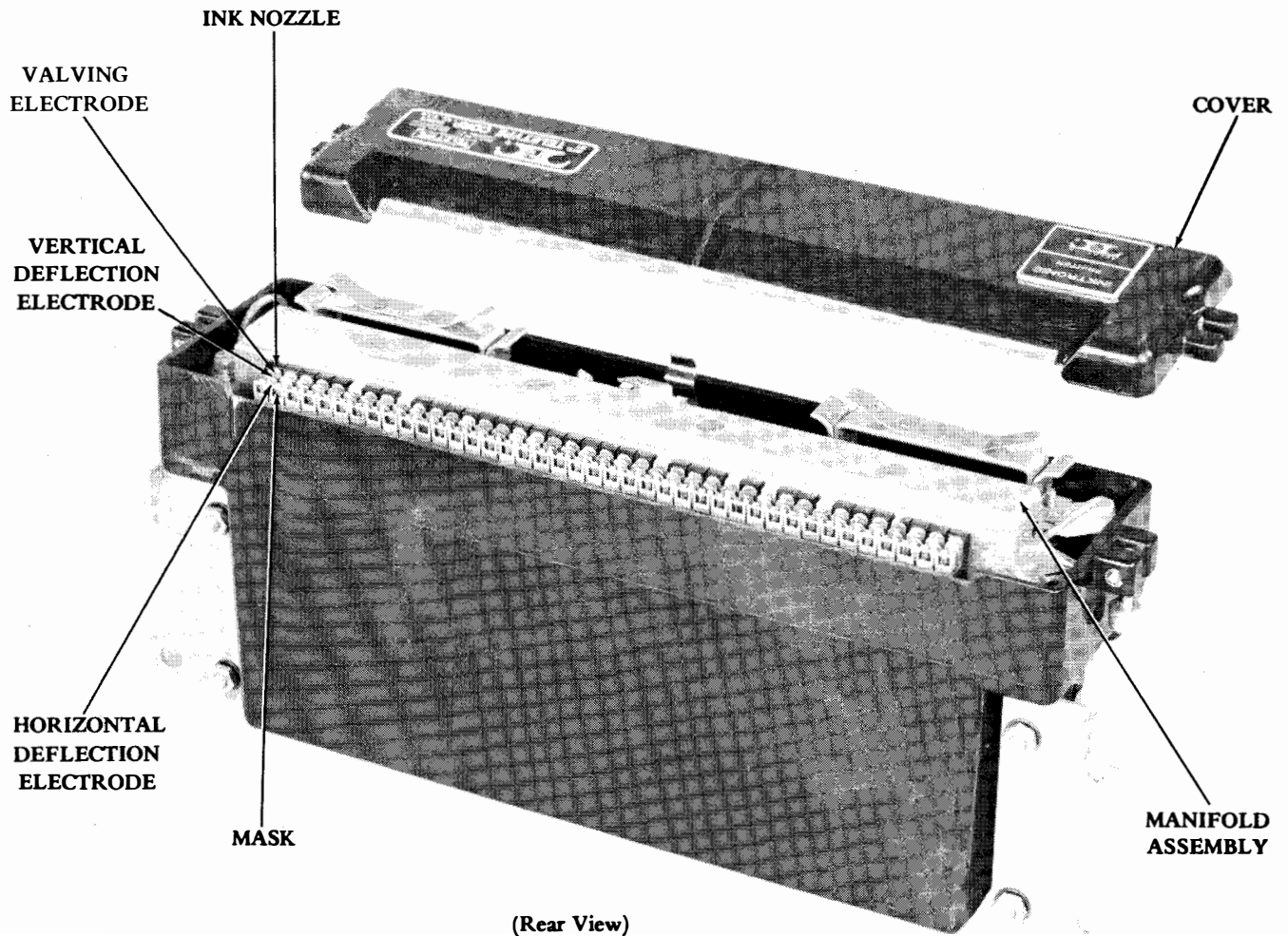

**Purpose**

The molded container encloses the ink reservoir, ink pump, heater, thermostats, manifold, and deflecting electrode assembly. This mechanism lifts minute quantities of ink from the reservoir, and accelerates and deflects the ink droplets to form the characters.

**Description**

The container with cover is approximately 4-1/2 inches high, 10-1/2 inches wide, and 2-1/2 inches deep, and weighs 8 pounds. The recorder assembly is supported and positioned by the front brackets on the paper transport mechanism. Late design units have a hinged access lid above the electrode assembly with a white character position scale stamped on it (not shown in illustration), and the metal strip down the center of the cover is omitted. They also have a continuous mask strip

instead of a mask for each individual set of electrodes, as shown in illustration.

**Operation**

The reservoir holds one pint of ink which provides for 1000 to 1500 hours of printing at 1200 wpm. The ink is heated and held at 133°F; the warmup time for a 70°F ambient temperature in about 15 minutes. The heater is normally on and the thermostats guard against an overheated condition. (Refer to wiring diagram 8344WD for a schematic diagram of the ink pumps and ink heater circuitry.) Refer to the text for electrode description.

**Maintenance**

The access lid found on late design units simplifies maintenance by permitting the electrodes to be cleaned without removing the cover from the set.

Figure 8 - Recorder (Cover Removed)

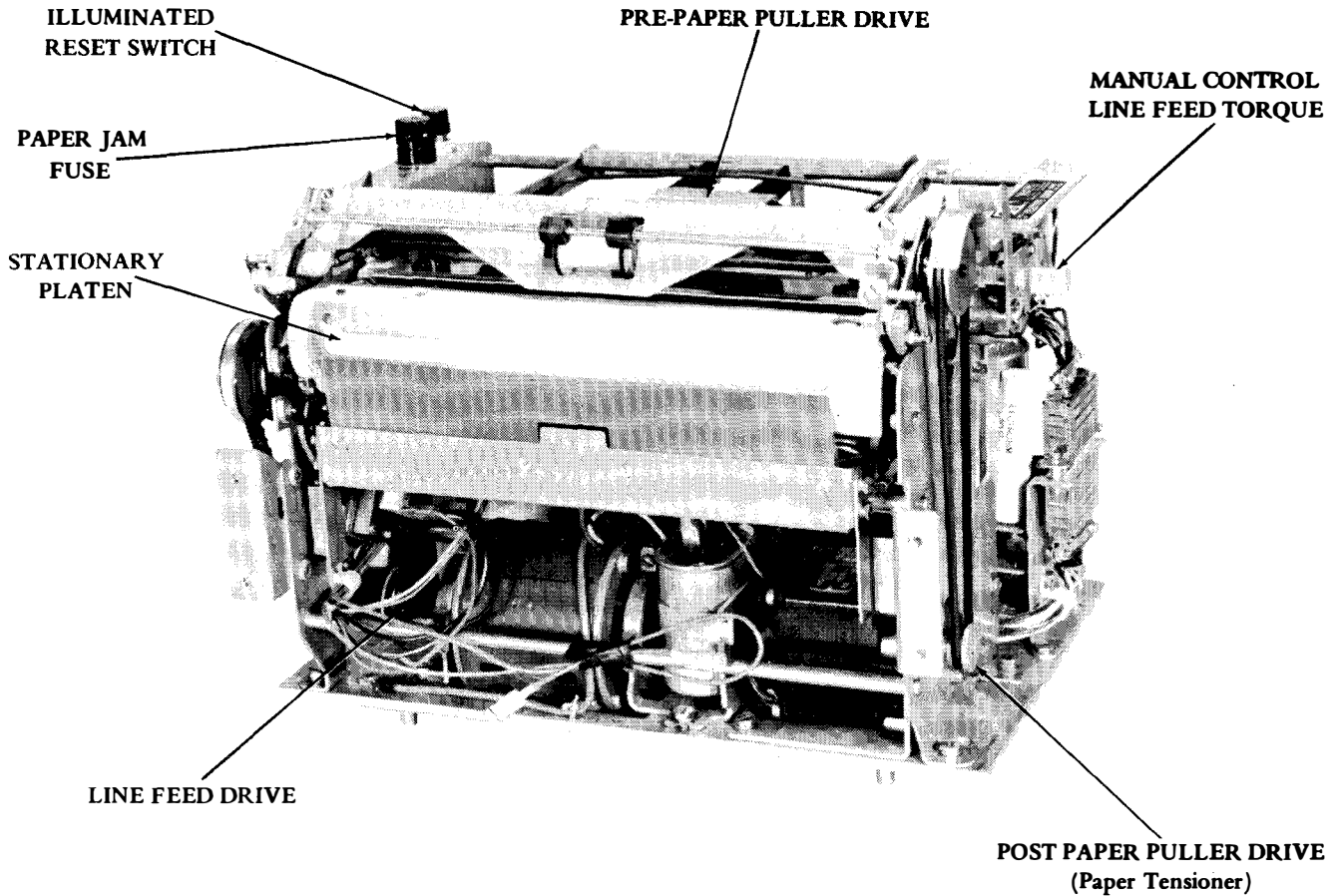

**Purpose**

The paper transport assembly steps the paper over the platen. The line feed assembly is an escapement type stepping mechanism which positions the paper by increments of 0.167 inch. The unit operates at speeds up to 1200 wpm. Three circuit boards located at the rear of the unit provide automatic control of the paper handling mechanism. The left rear corner of the unit houses the high voltage supply which furnishes the electrostatic charges for the elements of the recorder. The recorder is mounted in front of the platen.

**Operation**

Three separate motors provide the torque for (a) the pre-paper puller drive roller that strips paper from the supply roll and forms a paper loop that is free of tension, (b) the line feed drive roller which advances the paper 10 lines per inch, and (c) the post-paper puller drive roller (paper tensioner assembly), which provides essentially constant paper tension during the feed cycle. Refer to Section 578-500-110 (formerly Section 592-820-110) for further description.

**Description**

The dimensions of the transport mechanism are approximately 12 inches wide, 9-1/2 inches high, and 8-1/2 inches deep.



**NOTE:** Late design units look slightly different from the unit illustrated. Their function is unchanged, except that a paper-out switch (mounted on pre-paper puller drive mechanism) takes over part of the function of one of the circuit boards at the rear of the unit.

Figure 9 - Paper Transport Mechanism



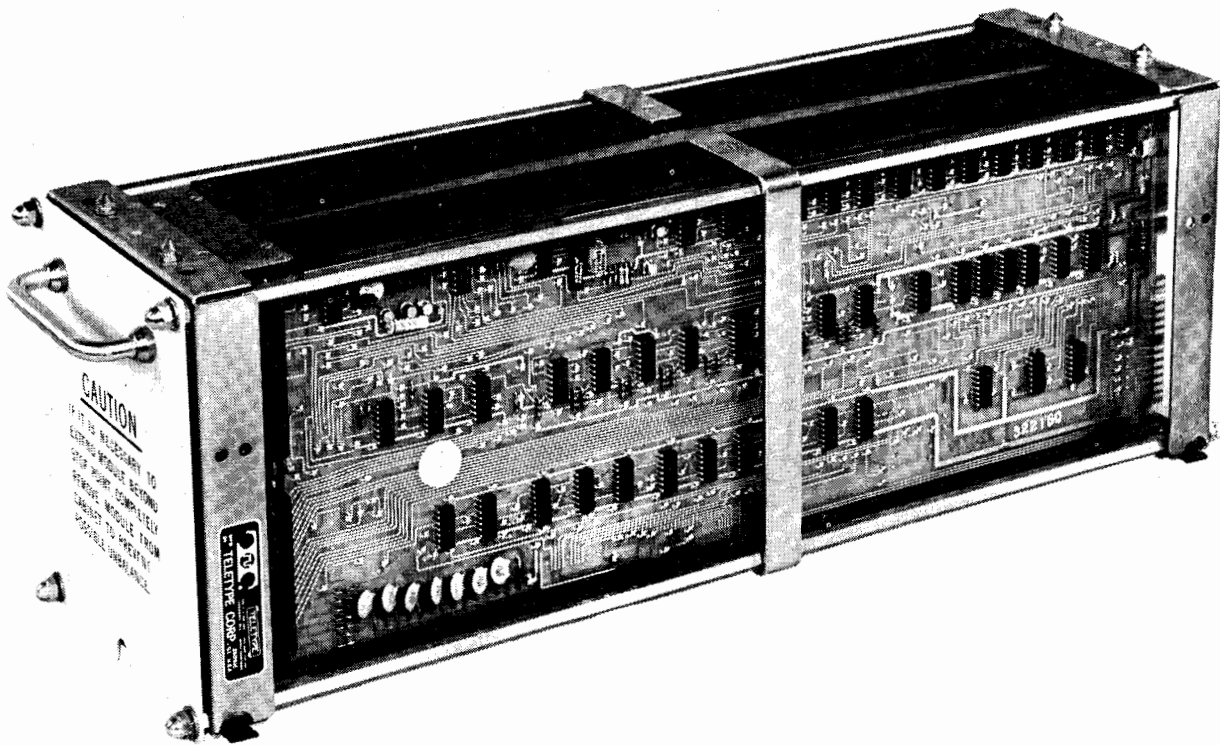

**Purpose**

This module contains the memory and logic system which translates the parallel digital signals from the interface module into the appropriate signals and sequences required by the spacing and tracing drive circuits (printer drive module) and the associated circuits of the printer set. These functions are obtained by a transformer type magnetic core memory with associated logic circuits. The carriage return, line feed, and spacing functions are initiated by the module in response to the incoming signals from the interface module.

**Description**

This assembly includes 64 printed wire character sheets, 4 circuit boards, 112 U-shaped ferrite cores, and the necessary connectors and hardware. The dimensions of the module are approximately 6-1/2 inches wide, 7 inches high, and 19 inches deep. The weight is approximately 10 pounds.

**Operation**

Each character shape is stored on a separate printed circuit sheet in the memory assembly, which has a capacity of 64 sheets. Characters can be changed by changing the printed sheets. Code changes require the changing of the memory program board and the control board (simple plug-in change for each board). The character shape is limited to a shape which can be made up of 31 dots or less.

Figure 11 - Character Generator Module

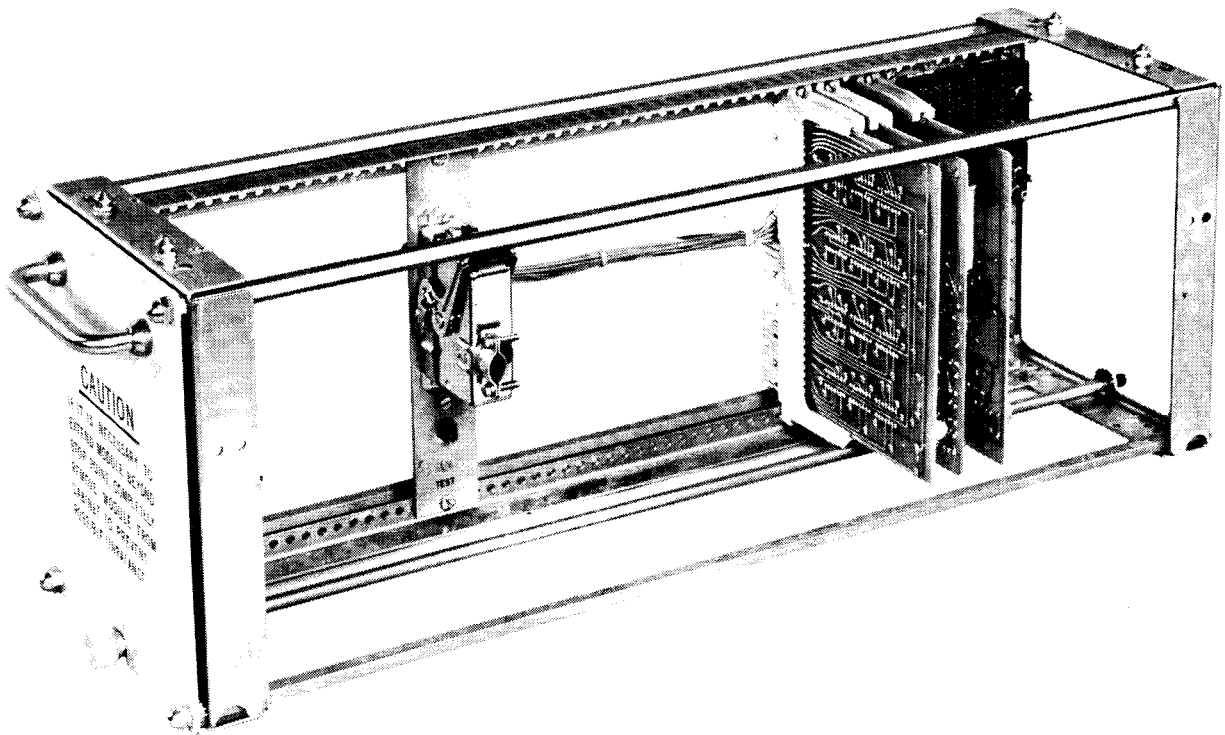

#### Purpose

This module assembly includes the logic circuitry that converts the incoming data and call control signals into appropriate signals and controls for the printing terminal. Flexibility in providing transmission and communication procedures is available. A TEST switch and (on late design units only) test character generator circuit is included to simplify maintenance.

#### Description

The dimensions are approximately 6-1/2 inches wide, 7 inches high, and 19 inches deep, and the module weighs about 10 pounds. Provision is made for discrete calling or other options.

#### Operation

Either of two modes of operation is available on the initial offering:

- (1) **Serial Interface Module:** Provides necessary station controls and signal conversions to enable a data interchange between a signal source such as a 202C or 202D data set and the nonimpact printer. It converts data from a polar serial asynchronous form to neutral parallel form.
- (2) **Parallel Interface Module:** Provides station controls and signal conversions to enable a data interchange between a signal source such as a 402D data set or equivalent and the nonimpact printer. It converts data signals from parallel contact closures or equivalent to neutral parallel (voltage) form.

Figure 12 - Interface Module

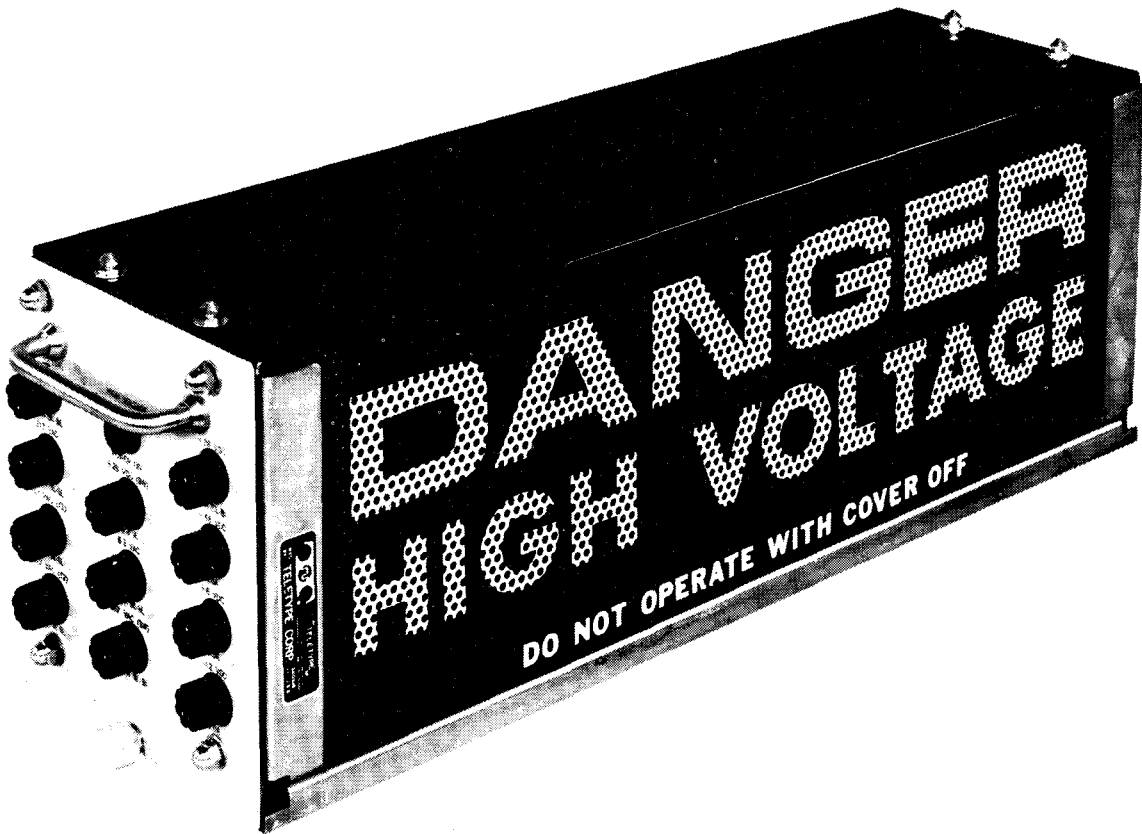

### Purpose

This module contains low and high voltage components that furnish the regulated multivoltage outputs for the various modules and assemblies of the printer set. The low voltage outputs energize the interface, character generator, and printer drive modules, and also supply certain paper transport, recorder and function strip assembly requirements. The high voltage outputs are routed through the printer drive module (+550 volts switched to respective valving electrode (total 40) and +3900 v dc plate supply for six high voltage amplifiers) to control the ink stream. A regulated ac output is furnished to the power supply located in the transport mechanism. Various reference voltages, signal lamp and relay supply voltages are provided by the module. Note that the interlock relays and alarm circuits are housed in this module but interconnected with the cabinet, paper handling, and cover switches to de-energize certain outputs when a malfunction is detected. Also the plate load resistors (6) for the high voltage amplifiers are contained in the left corner.

### Description

The overall dimensions are approximately 6 inches wide, 7 inches high, and 22-1/4 inches deep. The operating characteristics are as follows:

Input: 117 v ac  $\pm 10\%$ , 60  $\pm 1/2$  Hz, 6 amps.

Output: +3900 v dc, 20 ma; +550 v dc, 2.6 ma; +120 v dc, 6.0 ma; +28 v dc, 2.5 amps; 6.3 v ac, 2.0 amps; 167 v ac (peak), 50 ma; +6 v dc, 3.0 amps; -12 v dc, 0.5 amp; +48 v dc, 1.0 amp; 117 v ac fused, 0.5 amp.

### Operation

This is a self-regulating ferroresonant transformer and solid state rectifier assembly with regulated dc output. Refer to Section 578-500-111 (formerly 592-820-111) for further description.

Figure 13 - Power Supply Module

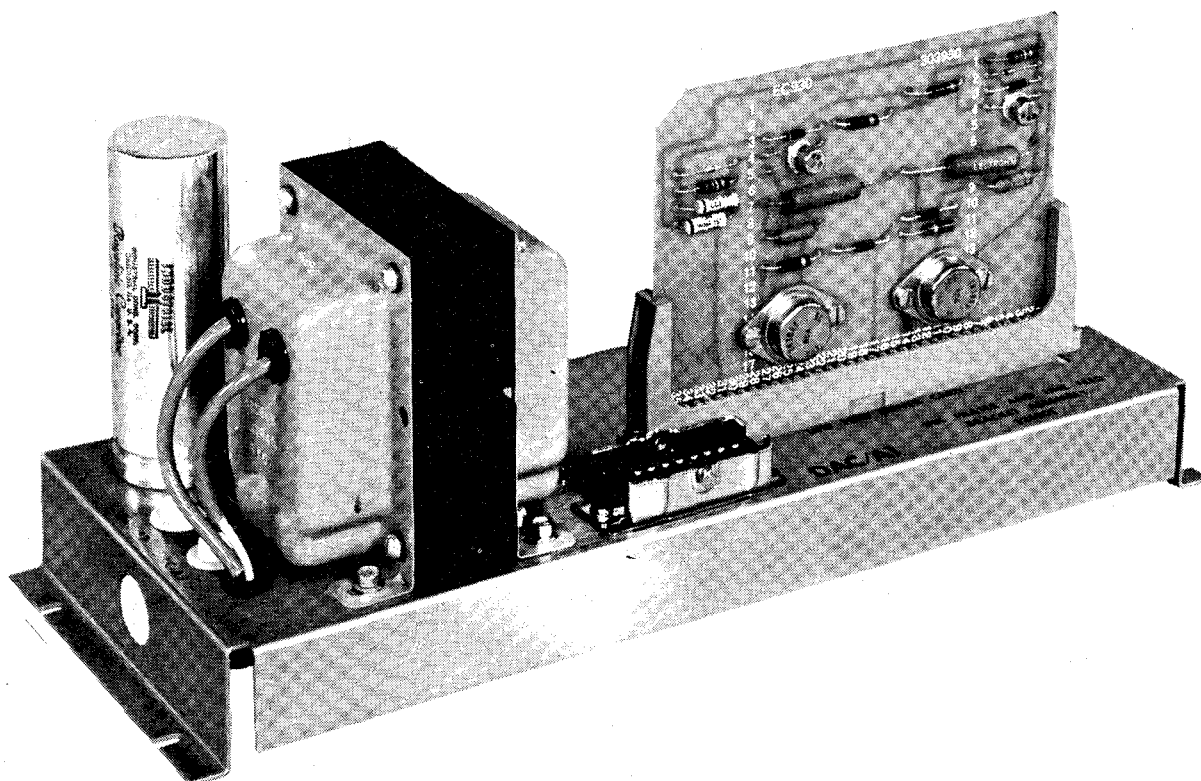

### Purpose

This assembly provides a dual function:

- (a) It supplies the heater current (26 v ac, 2.5 amps) for the recorder ink heater and the low potential which energizes the ink pump.
- (b) It contains the paper transport escapement magnet drivers and filter assembly.

The assembly is located at the upper left front corner of the cabinet. The chassis is cut out for the data set. Interconnecting cables transfer the energy to the respective character forming and paper transport mechanism.

### Description

The approximate dimensions of the bracket assembly are 5-1/2 inches wide at the rear end and 2 inches wide at the front, 6 inches high, and 13-1/2 inches deep.

### Operation

Referring to the wiring diagram (8344WD) it will be noted that the ink heater and the ink pump (vibrator type) are energized continuously unless the thermostat senses an abnormal condition. The triac is biased to pass current on each alternation, unless the ink temperature rises above 133°F. Should a malfunction of the thermostat occur, a second thermostat shuts off the ac input. Since the latter is a manual reset unit, it is necessary to remove the ink tank cover to service the assembly. Operation of the magnet drivers is explained in Section 578-500-111 (formerly 592-820-111).

Figure 14 - Ink Heater and Line Feed Bracket Assembly

## 3. PHYSICAL CHARACTERISTICS

## Dimensions

HEIGHT	WIDTH	DEPTH	REMARKS (See Notes)
47-3/4 inches	18 inches	27 inches	Less paper winder
55 inches	-	-	With paper winder

WEIGHT: Approximately 378 pounds.

**Note 1:** Provide 16-3/8 inch clearance at front for door to open.  
**Note 2:** Allow 13-1/4 inch clearance for top panel to slide forward.  
**Note 3:** Maintain at least 3-inch clearance between back of set and wall – make sure bumper (stand off) screws are in place.

## Electrical

INPUT	RUNNING CURRENT	IDLE	POWER FACTOR	REMARKS
117 volts ac $\pm$ 10% 60 $\pm$ 1/2 Hz	8 amps	-	-	12 ft, 3-wire (with ground) cable #16 AWG

## Temperature

OPERATING	STORAGE
+40° F to +110° F	-30° F to +110° F

## Signal Input:

Interface provisions. Disconnect timer; 15 sec min, 25 sec max. Field option – programmable; Jumper plug TP325186.

VARIATIONS	CHARACTER LENGTH	BAUD RATE	BIT TIMER	SHIFT REGISTER*	DATA SET OR EQUIVALENT	REMARKS
AAA	-	-	-	-	-	Basic
AAB	10 unit	1050	MC180	D	202C or D	
AAC	10 unit	1200	MC181	D	202C or D	
AAD	7.42 unit	890	MC182	A	202C or D	
AAE	7 unit	840	MC183	A	202C or D	

\*Refer to Section 578-500-200 (formerly 592-820-200) for strapping information.

## Parallel Interface

VARIATIONS	CHARACTER LENGTH	BAUD RATE	DATA SET OR EQUIVALENT	REMARKS
AAA	-	-	-	Basic
AAB	8	750	402D	



#### 4. OPERATION

4.01 With the receive-only printer set installed and ready for service, the power ON-OFF switch located in the lower ledge of the cabinet (behind front door) should be in its ON position at all times. All doors and covers must be fully closed and the paper must be properly threaded to complete the interlock and alarm circuit path. With no interruptions in the interlock string, the READY lamp will be lit. This signifies the terminal ready status to respond and turn on for printing.

#### MANUAL OPERATION

4.02 A manually controlled call may be either initiated or answered by the printer station in the normal manner for the high speed on-line data equipment. Depressing the DATA key on the data set will turn on the motors, the high voltages, the ON lamp, and the supervisory channel. The printer is now ready for operation.

#### RECEIVE-ONLY STATION WITH DISCRETE CALLING ACCESSORY

4.03 A call to an unattended sending station is placed in the usual manner. After completion of the 2025 hertz tone, the printer terminal goes to the DATA mode. The operator waits 5 to 10 seconds and depresses the TRAN START key. The lamp will light and remain lit for several seconds. The data should be printed within 10 seconds after the light is extinguished. If no data is received, the TRAN START key should be depressed again. If several attempts are made and no data is received, it can be assumed that the discrete calling identification code sent by the printer is not valid and the sender is not responding.

#### UNATTENDED OPERATION

4.04 To answer calls unattended, the printer READY lamp must be lit and the PAPER ALARM lamp must be extinguished. The data set AUTO key must be depressed. If these conditions exist, all incoming calls will be answered and printing will occur.

#### DISCONNECT PROCEDURES

4.05 Calls may be terminated in any of the following ways: (1) The operator can return to the TALK mode and lift and return the handset, (2) the sender can remove the carrier from the channel for 15 seconds and the printer will automatically turn off, or (3) a printer malfunction condition (open door, abnormal input on high voltage leads, faulty paper feeding, etc) will cause the READY light to turn off. Note that if any of the items listed in (3) occur, no further calls will be accepted until the faulty conditions are cleared.

4.06 The printer will automatically turn on after detecting the presence of an ON condition on the DCD lead from the data set, if the READY lamp is lit and the PAPER ALARM lamp is extinguished. The printer will automatically turn off after 15 seconds of an OFF condition on the DCD lead.

4.07 With reference to the brief description of the incoming signal as outlined above and a reference to the block diagram of Figure 15, the signal path through the three major modules (interface, character generator, and printer drive) may be reviewed. The multivoltage power supply, in addition to furnishing the ac and dc voltages for the various modules and assemblies, houses the interlock relays and certain resistors and components of associated modules. Since no direct signal path is involved in the power supply module, its circuit will not be discussed at this time. However, the output voltages of the power supply are indicated in the block diagram of Figure 15. The regulated high voltage power supply on the paper transport assemblies is also shown in the block diagram. Its outputs provide the high dc operating voltages for the recorder electrodes, but since it is not involved in the signal flow, it will not be discussed at this time.

4.08 Referring to the block diagram of Figure 15, the incoming data from the data set is applied to the interface module. The output of this module is a digital signal consisting of seven parallel bits plus a timing signal. Depending on the nature of the incoming signals (serial or parallel form), a serial interface module (DAIF1) or parallel interface module (DAIF2) is used in the installation. In either case, the interface module provides control signals for the printer and data set, but the serial interface module also provides a serial-to-parallel conversion of the input signal.

4.09 The output of the interface module is applied to the character generator module. The character generator is basically a memory and logic system which translates the code bits from the interface module into low-level binary signals for the printer drive and line feed circuits. As indicated in the block diagram, line feed information is processed by the circuitry on the ink heater and line feed bracket, and applied to the line feed mechanism in the paper transport. The character generator also develops tracing drive information (to control the deflection of the ink stream in printing a character) and spacing drive information (to control the valving action that determines the character position on the line). The incoming signal (code bits) is stored for 8 milliseconds while the logic processes a memory subroutine selected by this code combination. The logic circuits sequentially interrogate the memory and store the information while the tracing drive processes it. Upon completion of the printing of the character, the spacing drive provides relocation to a new position on the line.

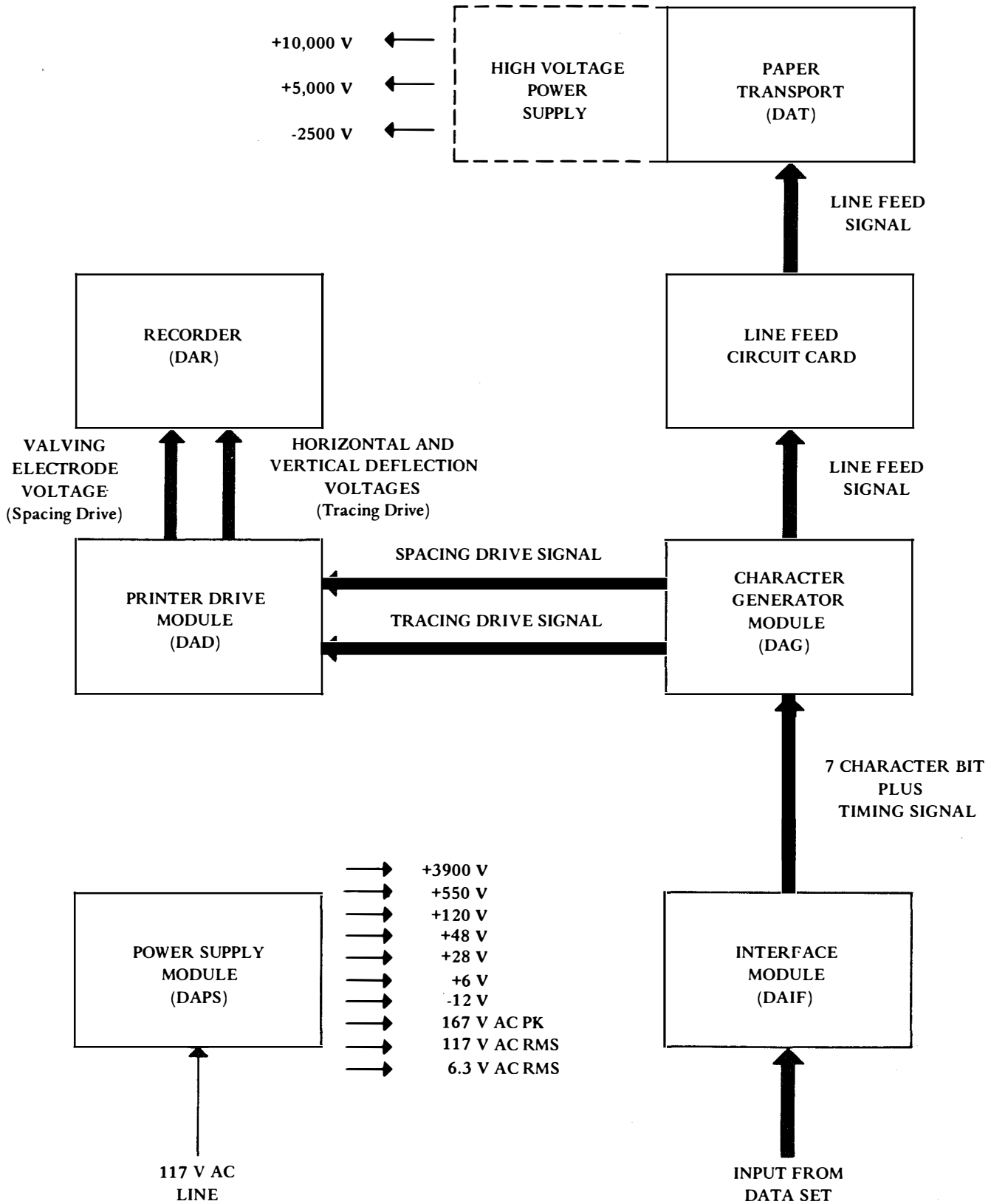

Figure 15 - General Data Flow in DATASPEED Printer

4.10 The printer drive module converts the low-level spacing and tracing signals (digital) from the character generator into high-level signals (digital spacing and analog tracing) for printing the characters in the recorder. Two large circuit boards provide the outputs. The spacing drive circuit board contains 40 relays; the tracing drive contains 6 high voltage amplifiers.

4.11 The circuitry on the spacing drive circuit board converts the binary outputs of the character generator logic for control of the printing position into high voltage signals for the recorder (column selection) valving electrodes. The input and output characteristics of these circuits are given below:

#### Spacing Drive (Column Selector)

##### Input Signals:

Five group signals, three binary signals and their complements.

##### Output Signals:

5 by  $2^3 = 40$  discrete outputs for the 40 sets of electrodes. 0 v = off, +550 v = on.

4.12 The tracing drive circuitry converts the digital output signals from the memory position of the character generator into high voltage analog signals required to deflect the ink droplets. The conversion is accomplished through the use of digital-to-analog converter circuits and

high voltage amplifier circuits. The input and output characteristics of the tracing drive circuits are given below:

#### Tracing Drive (Ink Stream Deflection)

##### Input Signals:

Four digital signals for vertical position.

Three digital signals for horizontal position.

One digital signal for jet up/down.

One digital signal for selecting the left or right position in a column.

One digital signal for selecting the first or second set of vertical amplifiers.

##### Output Signals:

Two complementary high voltage outputs for horizontal deflection.

Two sets of complementary high voltage outputs for vertical deflection.

4.13 Refer to Section 578-500-111 (formerly 592-820-111) for further description of the module circuits and to the installation Section 578-500-200 (formerly 592-820-200) for information with regard to strapping, bit timer, and pulse length requirements.

