

RADIO FREQUENCY INTERFERENCE (RFI) SUPPRESSION
 FOR 28 KEYBOARDS, 28 TRANSMITTER DISTRIBUTORS, AND 28/32 KEYBOARDS
 DESCRIPTION AND ADJUSTMENTS

CONTENTS	PAGE
1. GENERAL	1
2. DESCRIPTION	1
28 RFI KEYBOARDS AND TRANSMITTER DISTRIBUTOR	1
RFI COMPONENTS OF 28 KEYBOARDS AND TRANSMITTER DISTRIBUTOR	2
28/32 RFI COMPACT SEND-RECEIVE (KSR) SET	2
SYNCHRONOUS PULSE FOR 28 RFI KEYBOARDS	2
SYNCHRONOUS PULSE FOR 28/32 RFI COMPACT KSR SETS	2
3. ADJUSTMENTS	2
28/32 RFI COMPACT KSR SET	2
Distributor Mechanism	
Armature spring	10
Clutch drum	5
Clutch shoe lever	5
Clutch shoe lever spring	9
Clutch shoe spring	9
Clutch trip lever	6
Distributor gear	7
Latch bail	8
Latch bail spring	10
Latchlever spring	10
Magnet blocking lever spring	10
Magnet plate	6
Reset lever	7
Trip lever spring	10
Keyboard Transmitter Mechanism	
Shutter window gap	3
Universal link	4
Universal link spring	4

1. GENERAL

1.01 This section presents a description of the components used in radio frequency interference (rfi) suppression as applied to 28 keyboards, 28 transmitter distributors, and 28/32 keyboards. It also presents the adjusting procedure for the 28/32 keyboard. In addition, this section is intended for use as a supplement to the following standard literature: Sections 573-116-100TC, 573-116-102TC, 573-116-703TC, and 573-127-102TC.

2. DESCRIPTION

28 RFI KEYBOARDS AND TRANSMITTER DISTRIBUTOR

2.01 Rfi as applied to 28 keyboards and transmitter distributors, consists of a double shielded contact box, a contact assembly, a filter card assembly, and a double shielded signal line cable with receptacle.



RFI Signal Generator
 Contact Box Assembly

RFI COMPONENTS OF 28 KEYBOARDS AND TRANSMITTER DISTRIBUTORS

2.02 The rfi signal generator contact box is composed of two metallic boxes. An inner box completely enclosed by an outer box. The two boxes are mechanically fastened together with fiber hardware and insulating material to electrically isolate each box from the other.

2.03 The contact assembly is provided with gold-plated contacts for low voltage operation. The assembly is enclosed within and electrically insulated from the inner box. The filter card assembly is mounted to and above the contact assembly. The filter is a network of three resistors and a capacitor mounted on a circuit board. When used in conjunction with associated shielded cables, power supplies, and keyer the filter provides a low-level interface and rfi suppression.

2.04 A double shielded cable assembly is provided to electrically connect the contact box to a three-pin electrical receptacle. The shielded cable is composed of three electrical conductors encircled by braided inner and outer shields. Two of the three internal wires are electrically insulated and transfer the telegraphic signals to associated equipment. The remaining wire is bare and electrically connected to the inner contact box, inner braid shield, and cable receptacle. The inner and outer braided shields are electrically separated from each other and the wires by flexible solid dielectric. The inner braid is electrically connected to the inner contact box and the outer braid is electrically connected to the outer contact box. The cable assembly provides rfi suppression when used with associated rfi equipment.

28/32 RFI COMPACT SEND-RECEIVE (KSR) SET

2.05 The rfi application for 28/32 compact (KSR) sets consists of photoelectric cells, shielded line signal cable, and a photoelectric distributor.

2.06 The signal generating mechanism utilizes photoelectric cells instead of a contact mechanism to generate a signal. A lamp assem-

bly provides the necessary light source to electrically activate the cells. A mechanical shutter assembly, linked with the keyboard codebars and located between the photocells and lamp assembly, provides windows to either allow light from the light assembly to pass and activate the cells (mark) or block the light and not activate the cells (space). The photocells will generate a parallel electrical signal of approximately 300 microamperes (ua). The generated signal travels along a shielded cable to a photoelectric distributor. The photoelectric distributor serializes the signal, and by means of shielded cables, routes it to the input of a polar line keyer.

SYNCHRONOUS PULSE FOR 28 RFI KEYBOARDS

2.07 A synchronous pulse mechanism on 28 rfi keyboards provides a means of remotely controlling the signal generator mechanism in order to govern the rate of signal transmission.

2.08 The incoming low-level synchronizing pulse is applied to the clutch magnet driver circuit which in turn supplies power necessary to operate the clutch trip magnet. The clutch magnet conditioning contacts are gold-plated and have an associated filter circuit to provide rfi suppression. In addition, the clutch magnet conditioning contacts control the clutch magnet driver circuit.

SYNCHRONOUS PULSE FOR 28/32 RFI COMPACT KSR SETS

2.09 Synchronous pulsed transmission is accomplished by the reset mechanism and pulsed operation of the photoelectric distributor clutch magnet.

3. ADJUSTMENTS

28/32 RFI COMPACT KSR SET

3.01 The adjustments are presented in an order which should be followed if a complete readjustment of the rfi portion of the keyboard and base is made.

3.02 References made to left, right, front or rear, up or down, apply to the unit in its normal operating position.

3.03 Keyboard Transmitting Mechanism

SHUTTER WINDOW GAP

To Check

Depress LTRS key to move all T levers to their lowermost position.
Lift up first and last shutter with approximately one oz of force.

Requirement

There should be
Min 0.065 inch---Max 0.075 inch
gap between the upper edge of shutter window and shutter plate.

To Adjust

Loosen adjusting screws. Position lamp assembly to meet requirement.

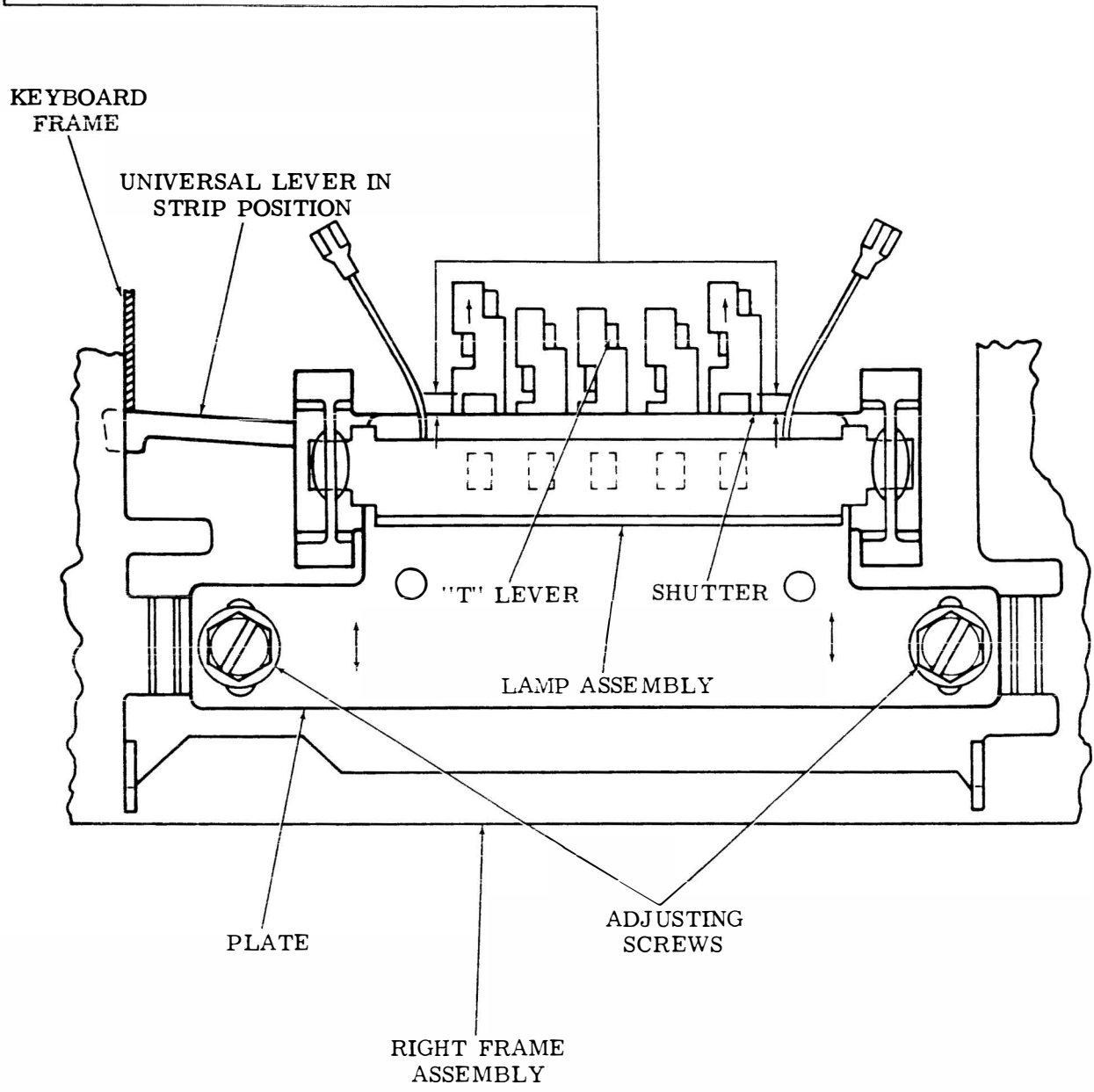

3.04 Keyboard Transmitting Mechanism (continued)

Note: Remove keyboard from subbase to facilitate the making of the following adjustments. For disassembly instructions, see Section 573-116-705TC.

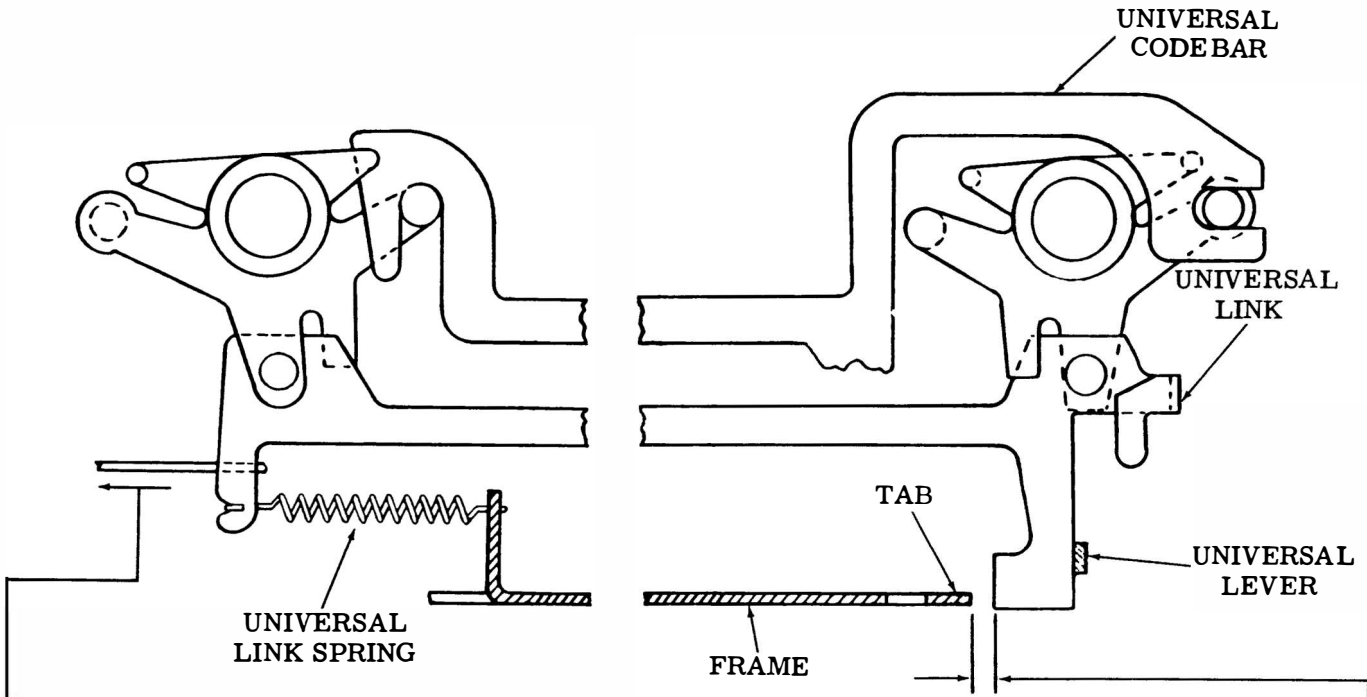

UNIVERSAL LINK SPRING

Requirement
 With keyboard tripped
 Min 1/2 oz---Max 1-1/4 oz
 start universal link moving.

UNIVERSAL LINK

To Check
 Push universal lever down until latched
 by latchlever.

Requirement
 Min 0.089 inch---Max 0.103 inch
 between universal link and frame.

KEYBOARD RESET LEVER SPRING

Requirement
 With keyboard reset lever latched
 Min 24 oz---Max 28 oz
 to start reset lever moving downward.

To Adjust
 Place screwdriver through opening in front
 of frame and bend tab.

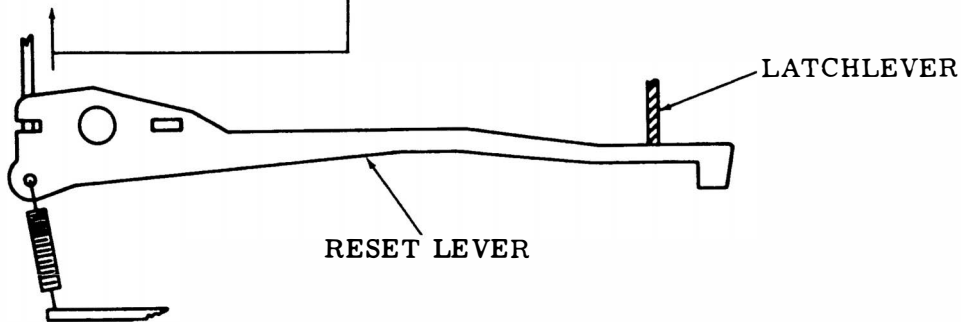

3.05 Distributor Mechanism

CLUTCH DRUM

(1) Requirement

With the clutch manually disengaged and pressed against the clutch drum, there should be

Min 0.005 inch---Max 0.010 inch between the ring and the hub protrusion.

To Adjust

Loosen clutch drum mounting screw and position clutch drum on its shaft.

Note: Do not distort ring when measuring gap between ring and hub protrusion.

(2) Requirement

The drive arm should be parallel to the surface of the drum assembly.

To Adjust

Gauge by eye and manually bend drive arm to meet requirement.

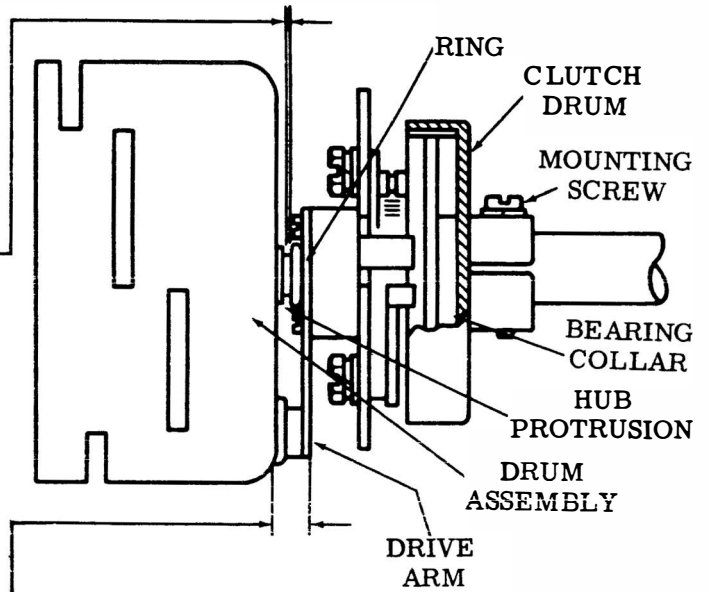

Note: Clutch shoes should fully engage drum after adjustment.

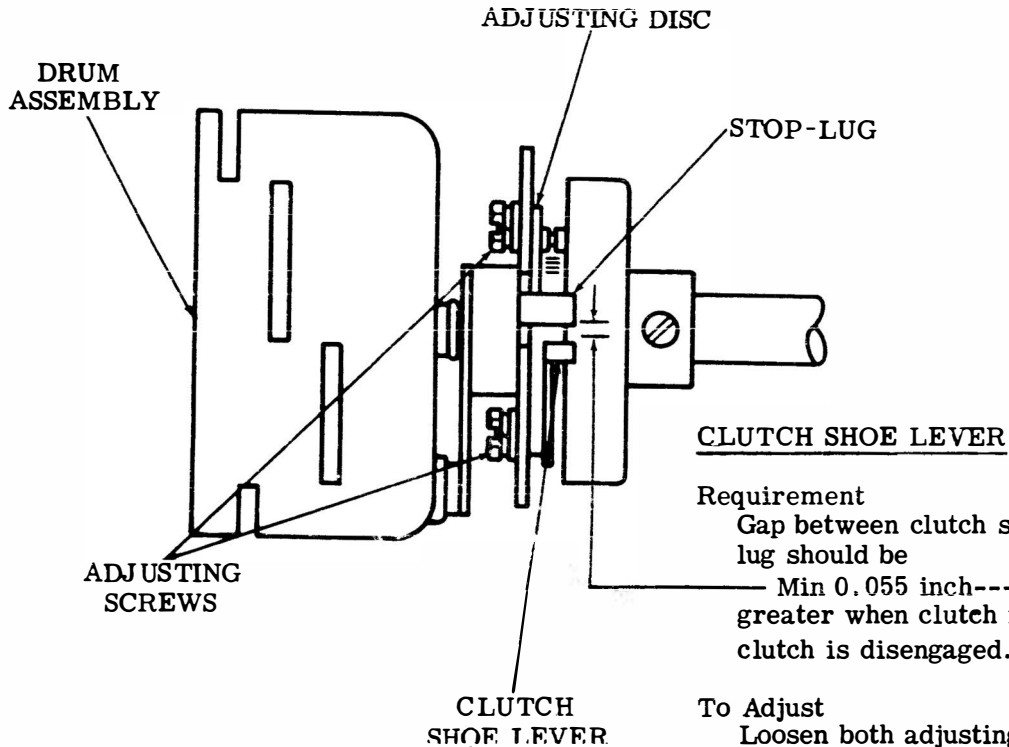

Requirement
Gap between clutch shoe lever and its stop-lug should be
Min 0.055 inch---Max 0.085 inch
greater when clutch is engaged than when
clutch is disengaged.

To Adjust
Loosen both adjusting screws and rotate
disc.

3.06 Distributor Mechanism (continued)

CLUTCH TRIP LEVER

Requirement

Clutch trip should engage clutch shoe lever by full thickness of the shoe lever.

To Adjust

Disengage distributor clutch and rotate the eccentric post to meet requirement.

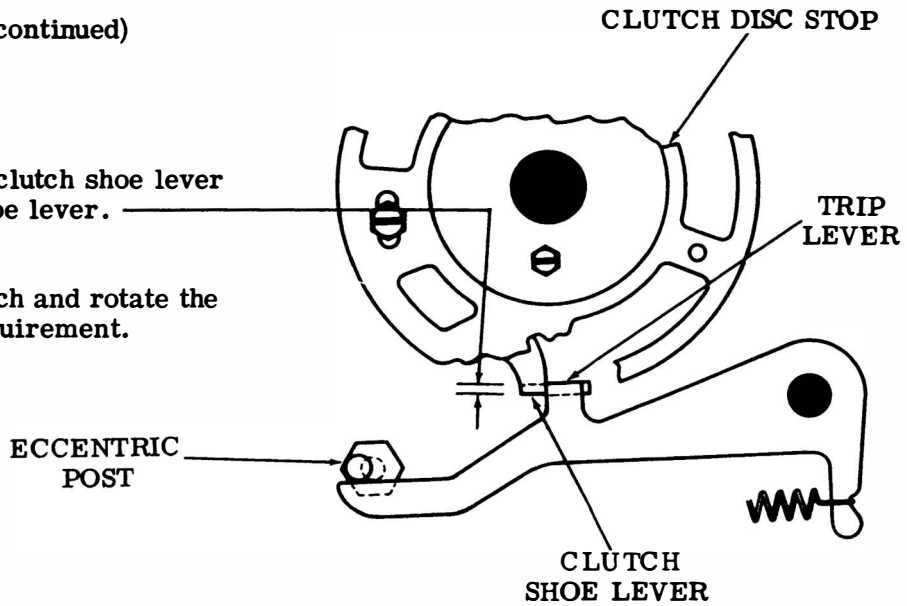

MAGNET PLATE

Requirement

With distributor in its stop position, control lever in remote position, and latch bail against armature, there should be

Min 0.020 inch---Max 0.040 inch between latch bail and trip lever.

To Adjust

Loosen both mounting screws and adjust gap by moving pry points.

Note: If distributor is mounted to keyboard base and mechanically linked to keyboard, depress key to trip keyboard.

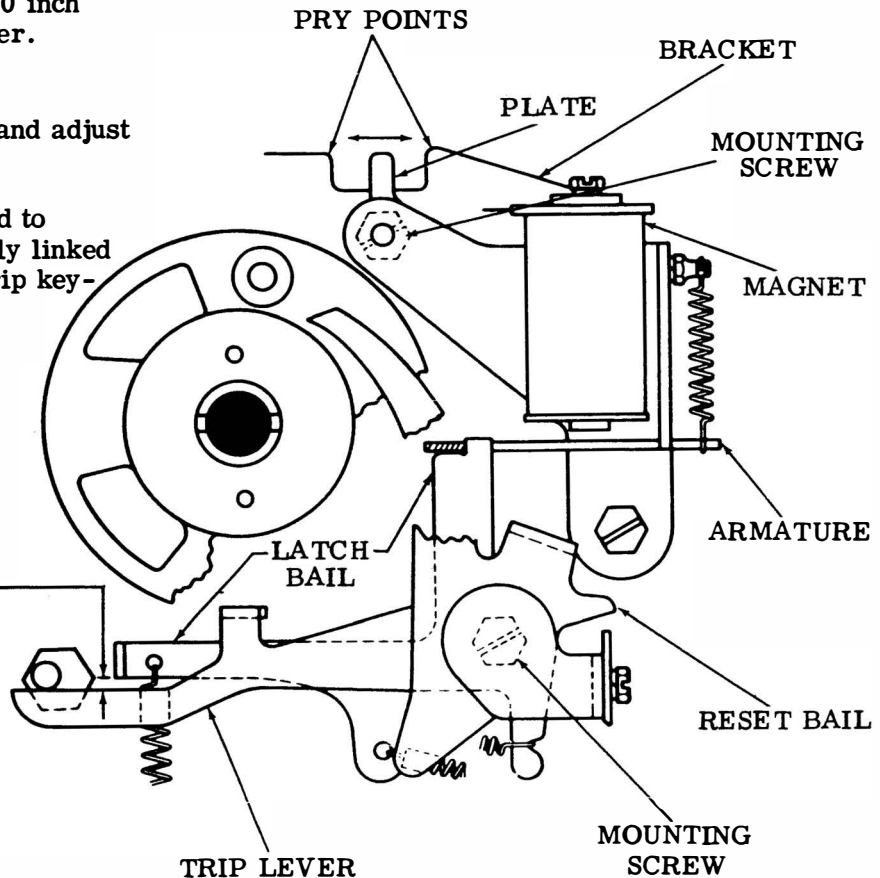

3.07 Distributor Mechanism (continued)

DISTRIBUTOR GEAR

Requirement

There should be
Min 0.002 inch---Max 0.005 inch
backlash between pinion and driven gear.

To Adjust

Loosen four adjusting screws and position distributor assembly to meet requirement.

Note: Parallelism should be maintained between the distributor shaft and pinion gear shaft.

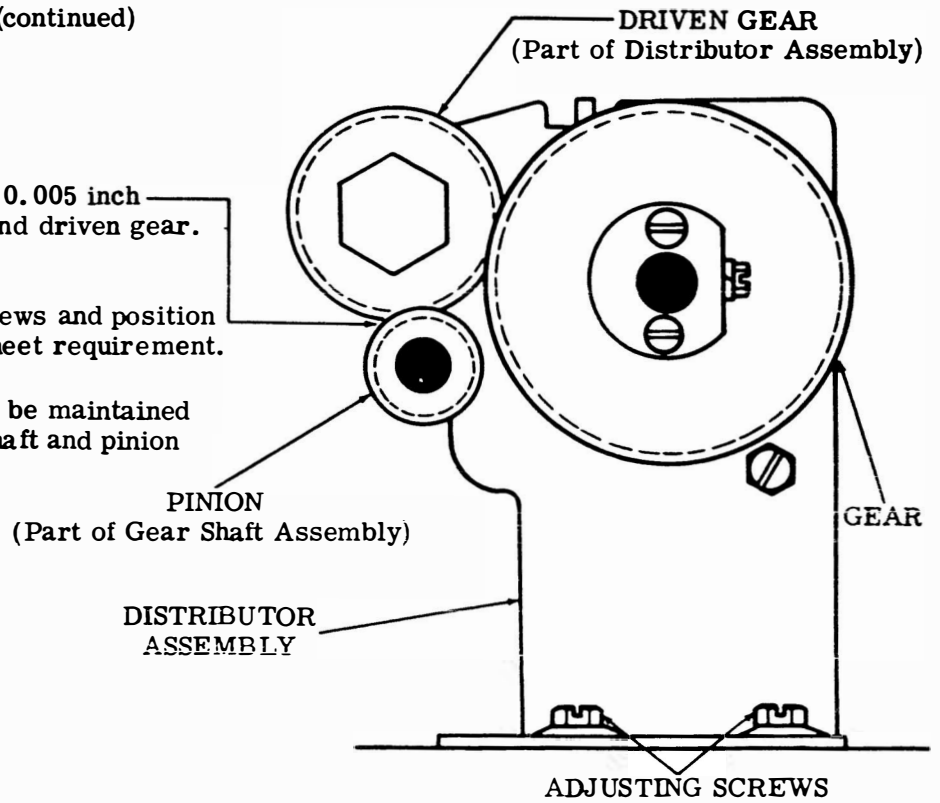

RESET LEVER

To Check

Rotate distributor so that roller is in contact with reset bail at high point of its travel.

(1) Requirement

There should be
Min 0.030 inch---Max 0.045 inch
gap between latchlever and reset lever.

(2) Requirement

There should be
Min 0.050 inch---Max 0.090 inch
between base and links.

To Adjust

Loosen adjusting screws and position link to meet requirements.

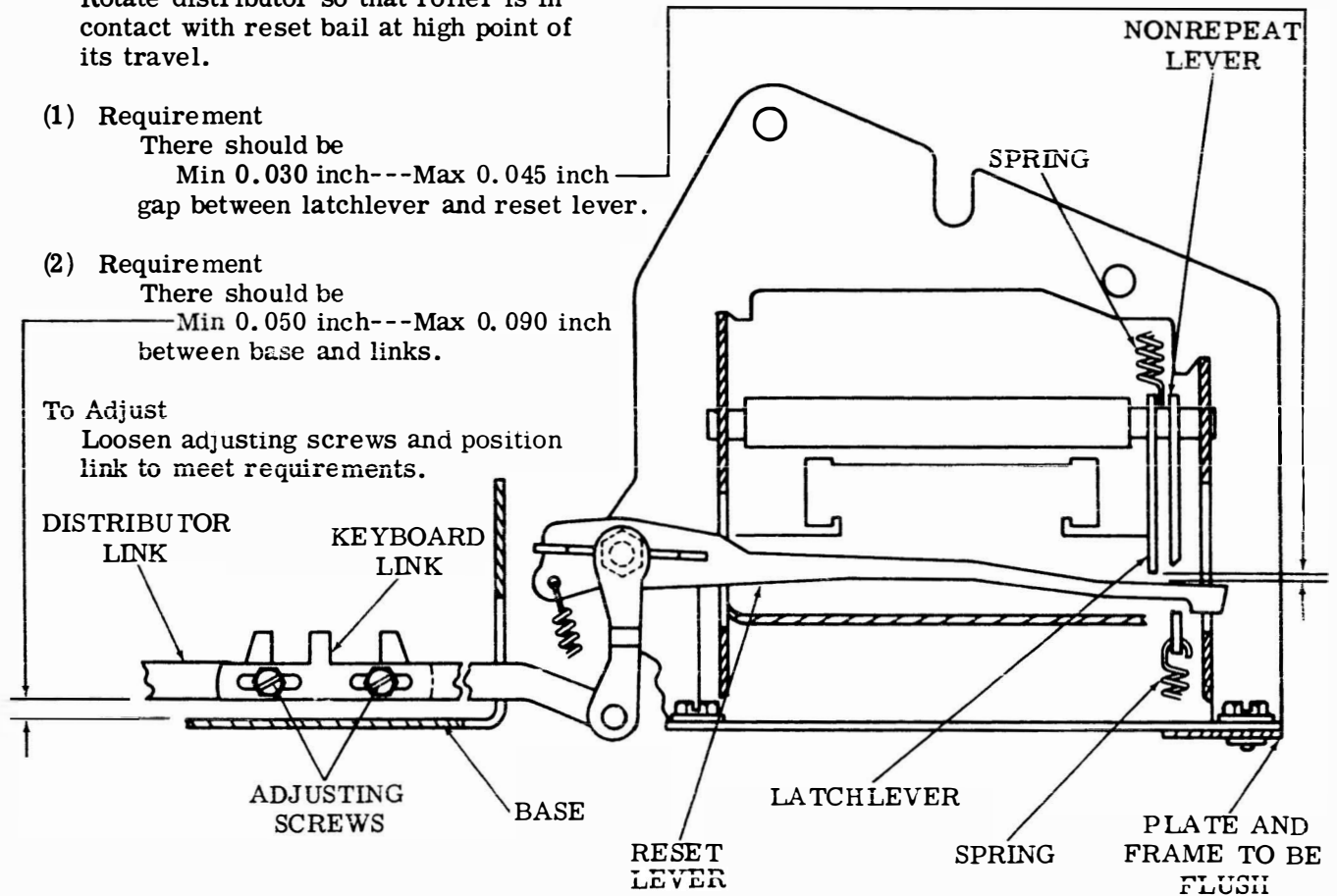

3.08 Distributor Mechanism (continued)

LATCH BAIL

To Check

With distributor in stop position, keyboard in reset position, and control lever in remote position, insert a 0.025 inch gauge between latch bail and armature.

Requirement

There should be

Min 0.010 inch---Max 0.018 inch
gap between the latch bail and the armature.

To Adjust

Loosen mounting screw and move adjusting plate so that it contacts reset bail. Tighten mounting screw.

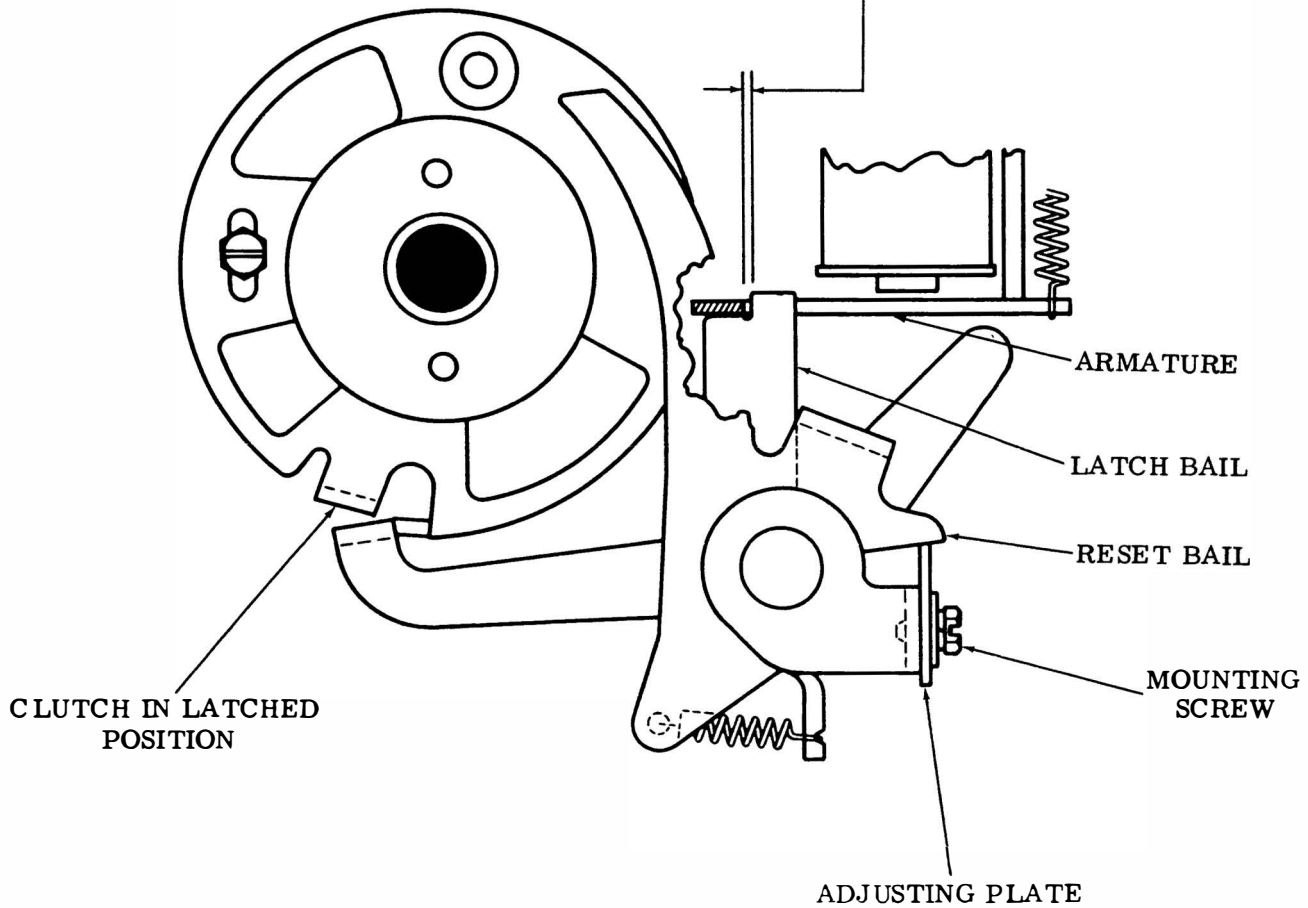

3.09 Distributor Mechanism (continued)

CLUTCH SHOE LEVER SPRING

Requirement

Clutch engaged. Hold cam disc to prevent turning. Spring scale pulled at tangent to clutch.

Min 15 oz---Max 20 oz
to pull shoe lever in contact with lug on clutch disc.

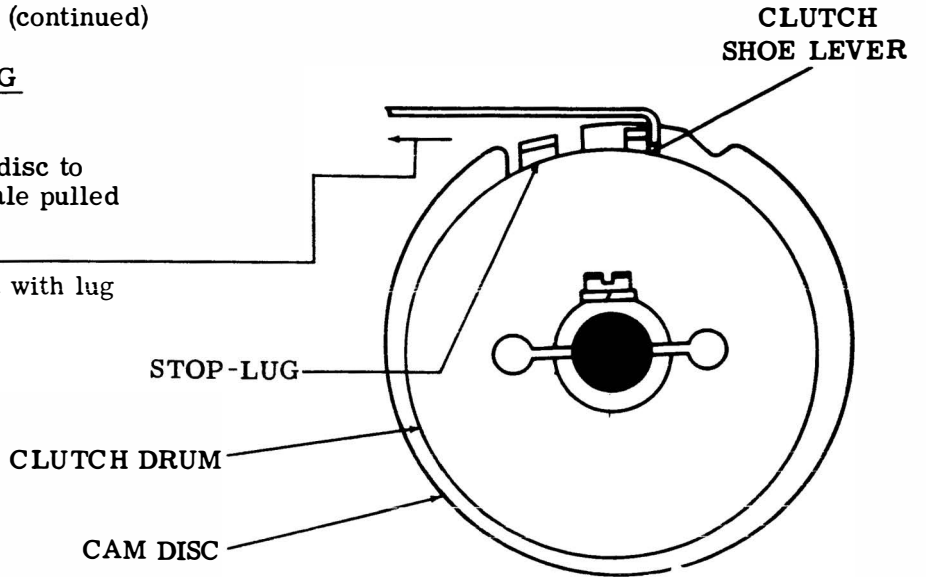

Note: As it requires removal of clutch from shaft, the following spring tension should not be checked unless there is good reason to suspect that it will not meet its requirement.

CLUTCH SHOE SPRING

Requirement

Clutch drum removed, spring scale applied to primary shoe at a tangent to the friction surface.

Min 3 oz---Max 5 oz
to start primary shoe moving away from secondary shoe at point of contact.

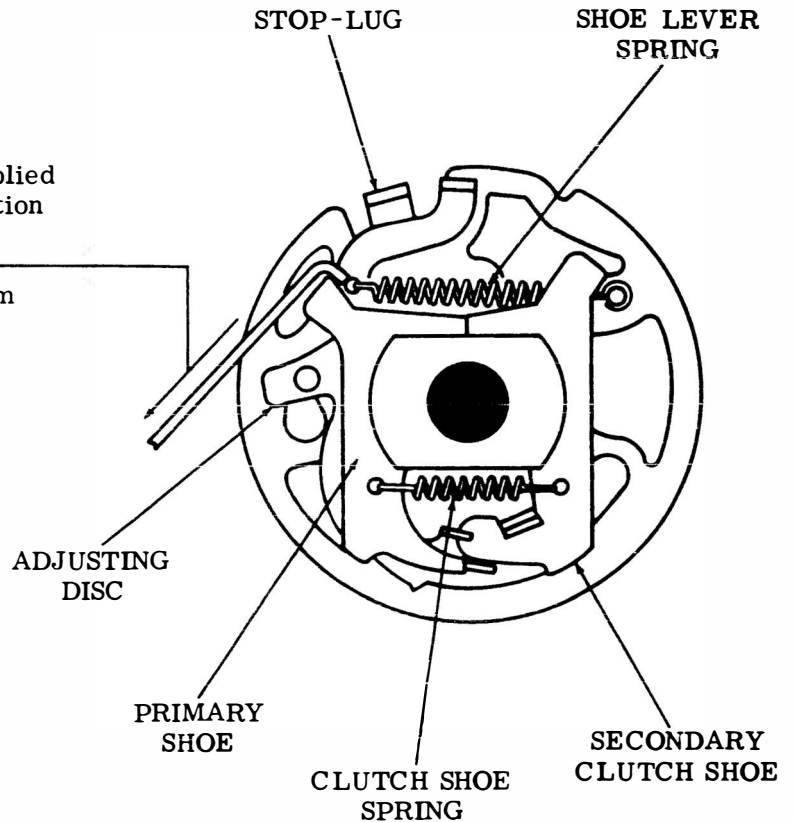

3.10 Distributor Mechanism (continued)

ARMATURE SPRING

Requirement

Spring unhooked from post
Min 6 oz---Max 7-1/2 oz
to pull spring to installed length.

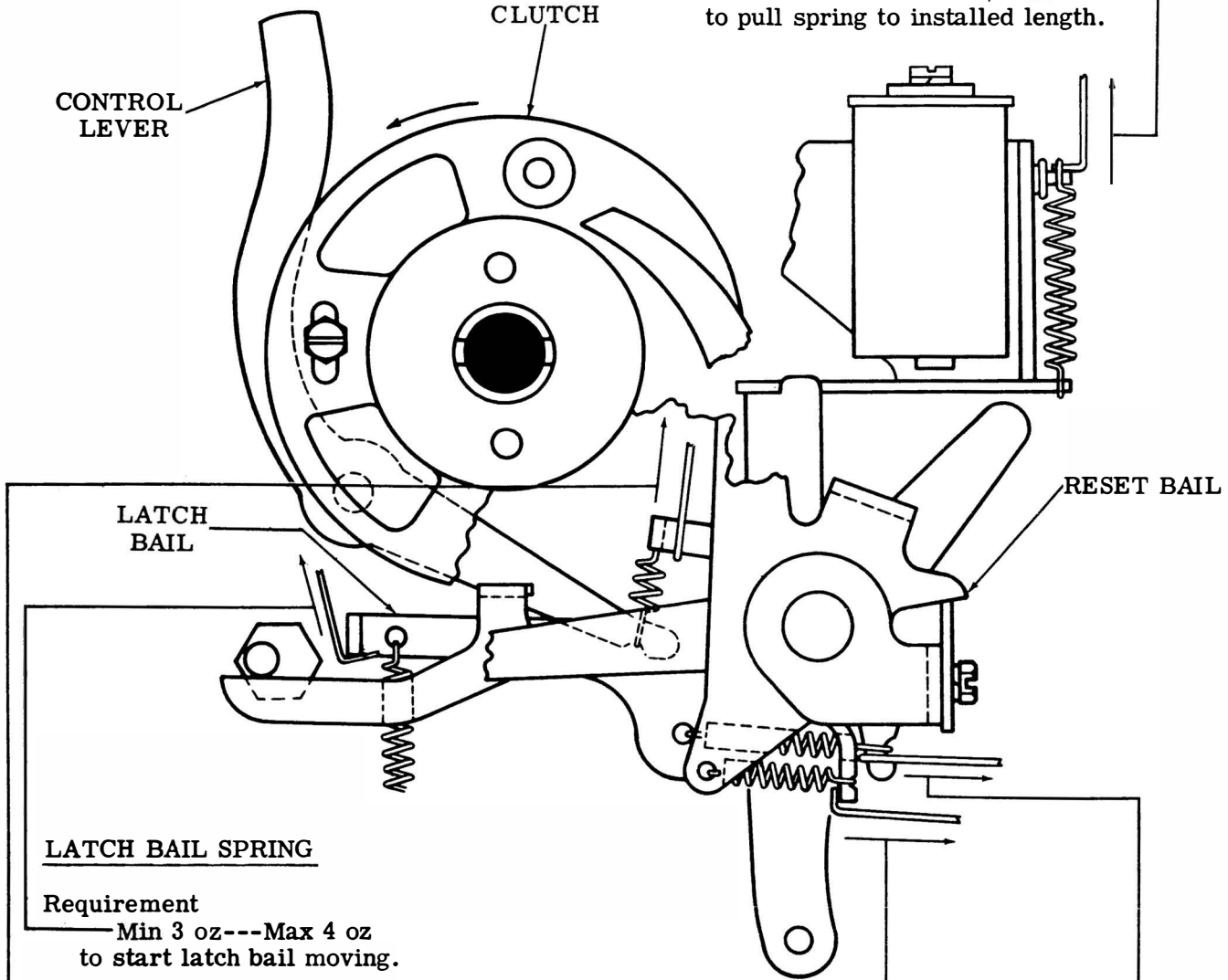

LATCH BAIL SPRING

Requirement

Min 3 oz---Max 4 oz
to start latch bail moving.

LATCHLEVER SPRING

Requirement

Min 2-1/2 oz---Max 4 oz
to start latchlever moving.

MAGNET BLOCKING LEVER SPRING

Requirement

Min 20 oz---Max 26 oz
to start blocking lever moving.

TRIP LEVER SPRING

Requirement

Min 3 oz---Max 5 oz
to start trip lever moving.