

28 TELETYPEWRITER CABINETS - FOR KSR AND RO SETS

ADJUSTMENTS

CONTENTS	PAGE	CONTENTS	PAGE
1. GENERAL	1	Top and middle printer cover depth	12
2. ADJUSTMENTS	3	Winder assembly	15
LAC - 28B through 28E and 28J Teletypewriter Cabinets	3	Window.	12
Armature spring	8	LPC (Skin Tight) — 28A Teletype- writer Cabinets	17
Copyholder	5	Copyholder	5
Copyholder bracket and top bracket alignment on table mounted cabinet	10	Dome centering	17
Copy lamp.	5	Indicator and copy lamps	5
Copy window	7	Paper guide.	12
Counterbalance	4	Small door	17
Cradle	8	Window.	12, 17 12
Detent arm and detent bracket	4	LPC (Multiple Mount) — 28L and 28M Teletypewriter Cabinets	18
Directory holder	10	Carriage return/line feed/and break lever	21
Dome.	3	Copy lamps	22
Dome catch.	3	Hinge mounts.	18
End-of-form lever	9	Keytop cover.	19
Front form guide	6	Keytop guide and cover	20
Guide bracket	6	Keytop guide plate cover	19
Indicator lamp.	5	Lower door hinge mounts.	21
Low-paper and paper-out spring.	9	Lower door latches.	21
Pivot arm and line guide	10	Paper guide.	22
Rear form guide.	6	Power switch.	20
Remote signal bell	8	Small copyholder	5
Small door	4	Window.	22
Small door catch	3	Window door hinge mounts.	21
Small door stop arm.	4		
Window and paper guide.	5		
LBAC — 28LA Teletypewriter Cabinets.	11	1. GENERAL	
Bearing bracket.	16	1.01 This section provides instructions for adjusting the 28 teletypewriter cabinets designed to house the Keyboard Send-Receive and the Receive-Only teletypewriters.	
Carriage return and line feed levers	14	1.02 In this issue, cabinets for the Automatic Send-Receive Sets have been removed. Wall-mounted cabinets for housing single 28 KSR or RO sets have been added, multiple page printer cabinets for housing three or four printer sets have also been added. Since this is a general	
Friction clutch torque	15		
Paper guide.	12		
Paper spindle cylinder regulating bushing.	15		
Paper spindle shaft endplay	15		
Printer covers.	11		
Printer cover latches	13		
Pulley alignment	16		
Slide stops	14		

SECTION 573-134-700

revision, marginal arrows ordinarily used to indicate changes and additions have been omitted.

1.03 Most cabinet adjustments are initial adjustments that are made at the factory and do not require routine adjusting unless mounting screws have become loosened or parts have been removed and replaced. Adjustments

most likely to need checking or remaking are outlined and illustrated herein. The figures show the adjusting tolerances, positions of moving parts, and spring tensions. Where an illustration shows interrelated parts, the sequence that should be followed in checking the requirements and making the adjustments shown is indicated by the letters (A), (B), (C), etc.

2. ADJUSTMENTS

LAC — 28B through 28E and 28J Teletypewriter Cabinets

2.01 Dome

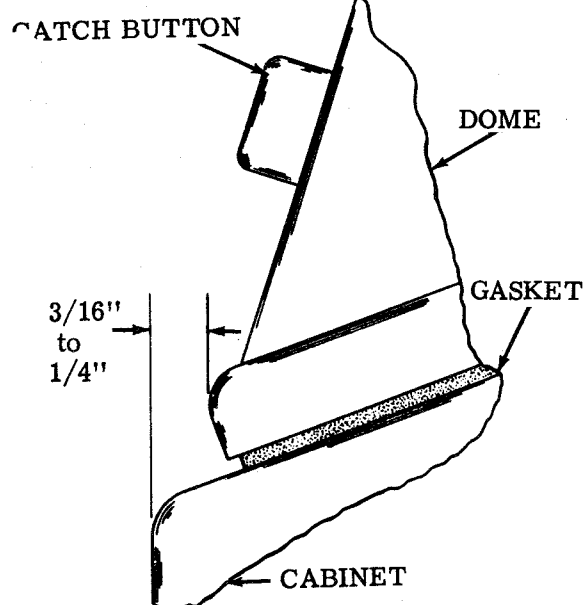
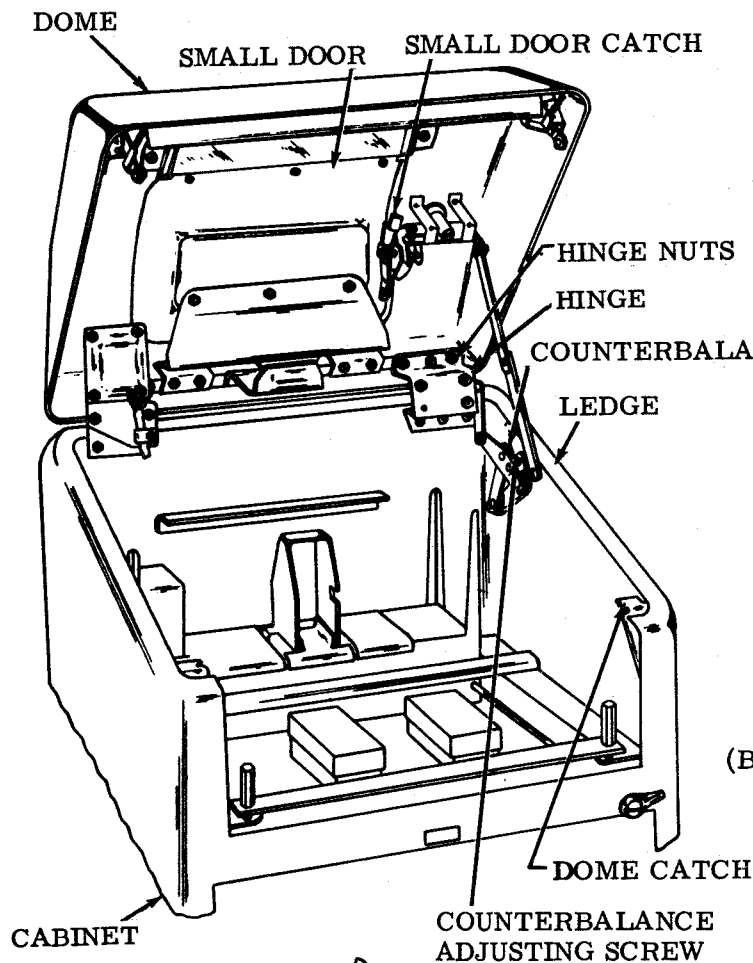

(A) DOMES

(1) Requirement

The dome should be centered on the cabinet from right to left and placed

Min 3/16 inch---Max 1/4 inch from the front edge of the cabinet.

To Adjust

Position the dome with the six nuts which secure the dome hinges to the dome loosened. Tighten the nuts.

(2) Requirement

There should be a light-proof seal at the rear of the dome between the rubber gasket and the top edge of the cabinet.

To Adjust

Position the dome downward with the six nuts, which secure the dome hinges to the cabinet, loosened. Tighten the nuts.

(B) DOMES CATCH

(1) Requirement

The dome should latch securely with a light-proof seal at the front of the dome between the rubber gasket and the top edge of the cabinet.

(2) Requirement

The dome catch should unlatch when the catch button is depressed no deeper than the outer surface of the dome.

To Adjust

Bend the two dome catches.

(C) SMALL DOOR CATCH

(1) Requirement

The small door should securely latch.

(2) Requirement

When the door is released from its catch it should spring open at least 1/2 inch.

To Adjust

Bend the small door catch. Recheck rear of door to make certain it is flush with or slightly above the dome.

2.02 Small Door

(A) SMALL DOOR

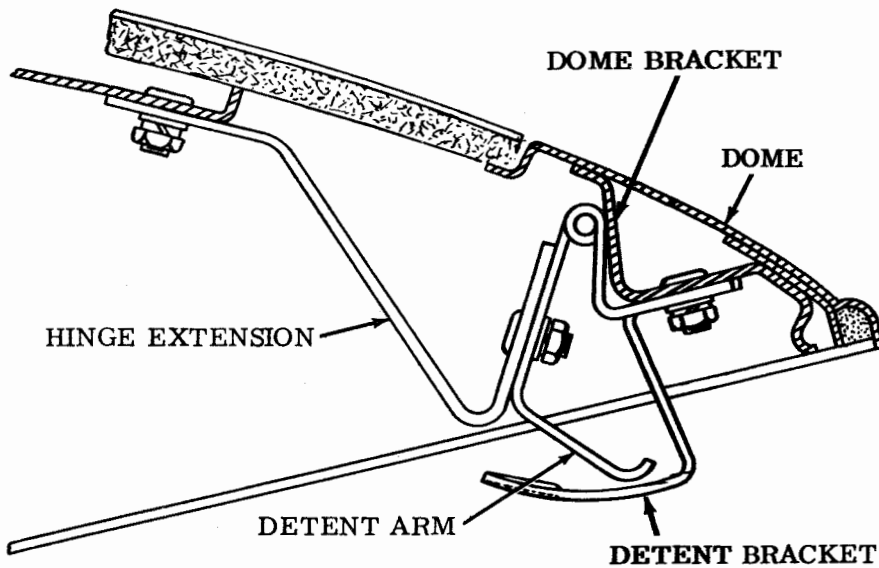

Requirement

The small door should be centered from right to left. It should be positioned so as to provide a light tight seal between the rubber gasket and the ledge of the dome at all points.

To Adjust

Loosen the two nuts that secure detent bracket to dome bracket. Loosen the two nuts that secure detent arm to hinge extension. Loosen the four nuts that secure door hinges to dome bracket. Push hinges against dome bracket and tighten the four nuts that secure hinges to

dome bracket. Loosen the three nuts that secure hinge extension to door. Slide door to its extreme forward position and position centrally from side to side with 1/32 inch minimum clearance on each side. Position the door so that it is flush with or not more than 3/32 inch above the dome. Door is to be parallel to within 3/32 inch. Tighten the three nuts that secure hinge extension to door. If the above requirements cannot be met, loosen the four nuts that fasten the door hinge to hinge extension. Position door flush with or slightly above dome so that the above requirements are met. Tighten the four nuts.

(B) DETENT ARM AND DETENT BRACKET

Requirement

With the dome closed, the small door should spring open at least 1/2 inch when released from its catch. The small door should remain in its detented position when the dome is opened into its fully raised position.

To Adjust

Position the detent arm and the detent bracket by means of their elongated mounting holes. Tighten the four nuts. If necessary reposition the detent arm. Recheck all nuts for tightness.

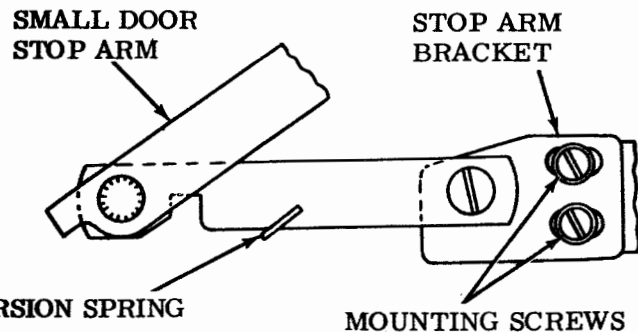

(C) SMALL DOOR STOP ARM

Requirement

Stop arm should be free of binds when door is opened or closed.

To Adjust

Loosen the stop arm bracket mounting screws. Close the door. Disconnect the torsion spring. Align stop arm for freeness and tighten mounting screws with door closed. Replace torsion spring.

(D) COUNTERBALANCE

Requirement

The dome should remain in its maximum open position and not close unless moved manually.

To Adjust

Turn the spring adjusting screw. (See Par. 2.01.)

2.03 Copyholder, Copy Lamp

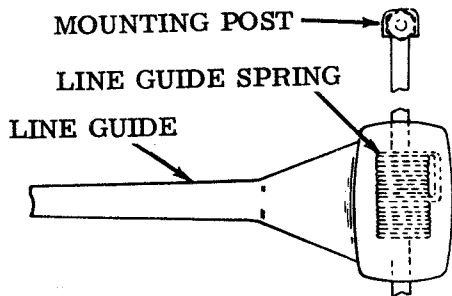
(A) COPYHOLDER**Requirement**

There should be sufficient tension on the line guide to hold copy in place and to prevent the line guide from slipping down its shaft. Line guide should be parallel to copyholder tray.

To Adjust

Remove the mounting screws or nuts from the line guide shaft and turn the shaft. Remount the shaft and tighten screws or nuts. Bend line guide to make it parallel to copyholder.

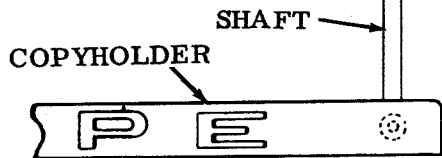
(B) WINDOW AND PAPER GUIDE (For cabinets housing friction feed typing units)(1) **Requirement**

When the small door is opened or closed, the window should clear paper guide by 1/16 inch.

Note: 0.080 to 0.110 inch on skin tight cabinet. (See Par. 2.16.)

To Adjust

Position window with its retainer screws loosened. Check to see that gasket is between glass and metal surface.

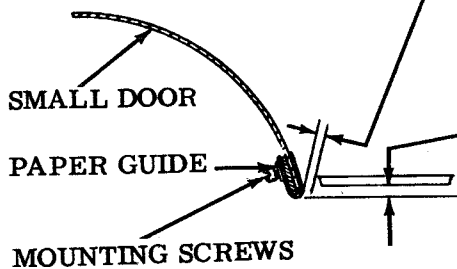
(2) **Requirement**

With small door closed, the bottom edge of the paper guide should be

Min 7/64 inch---Max 9/64 inch below bottom surface of window.

To Adjust

Position the paper guide with its mounting screws loosened.

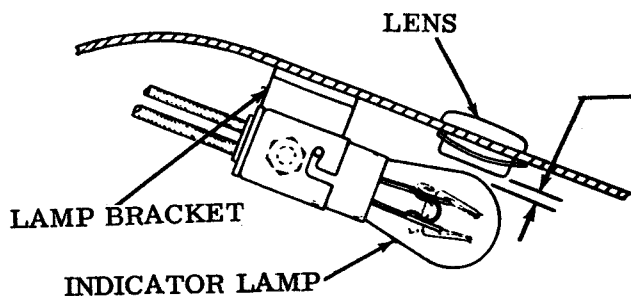
(C) INDICATOR LAMP**Requirement**

Clearance between indicator lamp and lens — approximately 1/16 inch.

To Adjust

Position lamp holder on its bracket with mounting screws loosened.

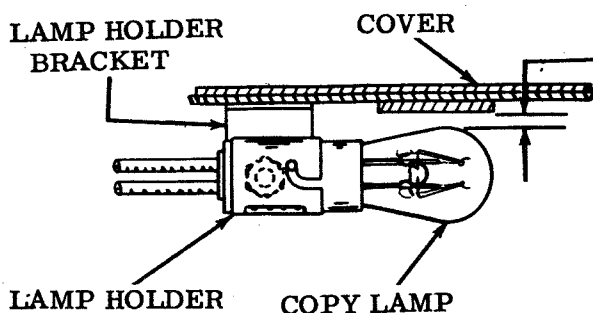
(D) COPY LAMP**Requirement**

Clearance between copy lamp and cover approximately 1/16 inch.

To Adjust

Position lamp holder on its bracket with its mounting nut loosened. (On skin tight cabinets, rotate shield for desired illumination.)

2.04 Form Guide

Note: The following four adjustments are for cabinets housing sprocket feed typing units.

FRONT FORM GUIDE

Requirement

With typing unit in cabinet and large and small doors latched, clearance between the lower edge of the front form guide and the platen should be
Min 3/64 inch---Max 5/64 inch

To Adjust

Loosen the form guide mounting screws. Press the paper guide against the platen, then raise the form guide parallel to the platen.

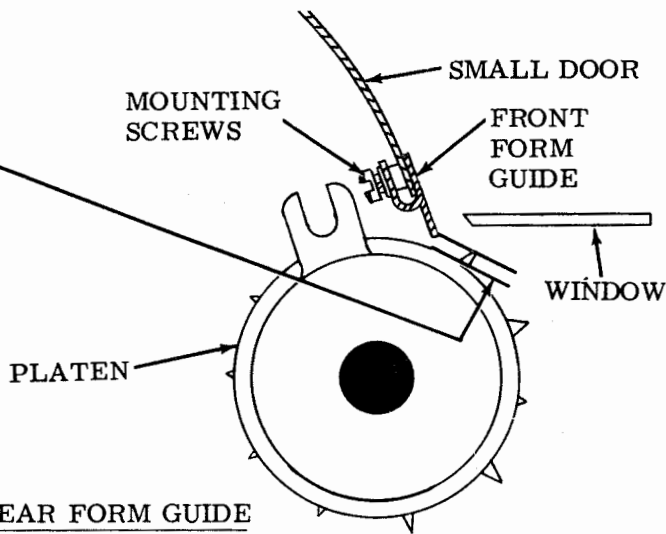

GUIDE BRACKET

Requirement

The guide bracket should be placed as far as possible to the left (rear view).

To Adjust

Position the guide bracket with its mounting screws loosened.

REAR FORM GUIDE

Requirement

With a sheet of sprocket feed paper placed in the form guide and pushed to the right (rear view) against the guide bracket, the clearance between the left edge of the paper and the guide post should be
Min 3/64 inch---Max 5/64 inch

To Adjust

Position the guide post with its mounting nut loosened.

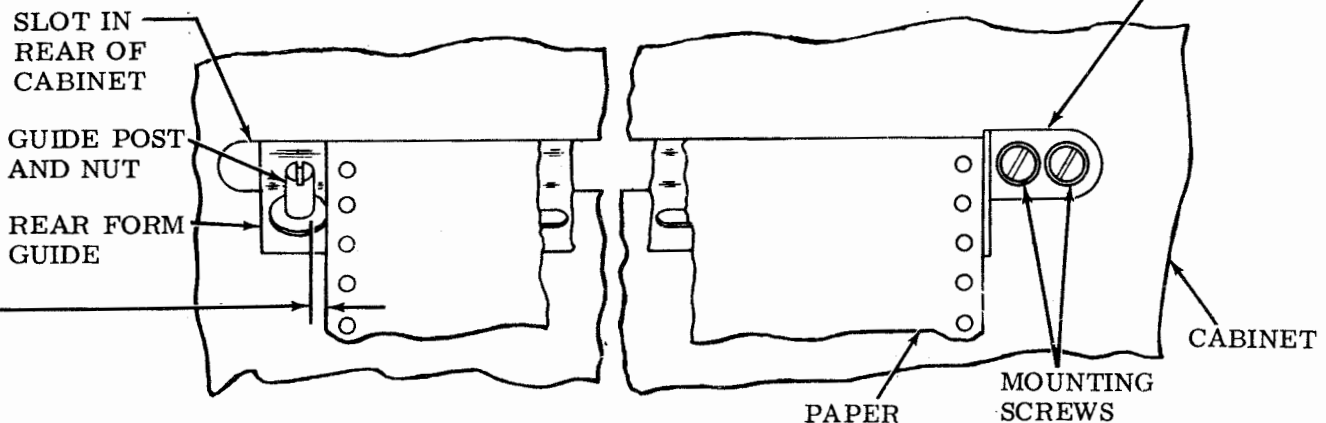

2.05 Form Guide (continued)

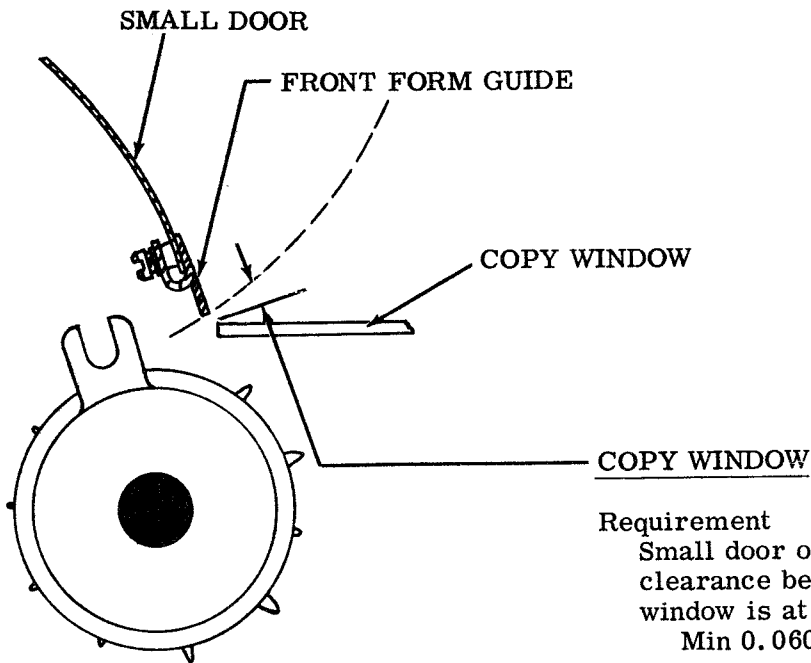

(LEFT SIDE VIEW)

Requirement

Small door open and positioned so that clearance between front form guide and window is at minimum clearance.
 Min 0.060 inch---Max. 0.080 inch

To Adjust

Position window with four window retainer mounting screws loosened.

Note: If stapled paper is used, staples should pass freely through slot. If they do not, increase clearance as required.

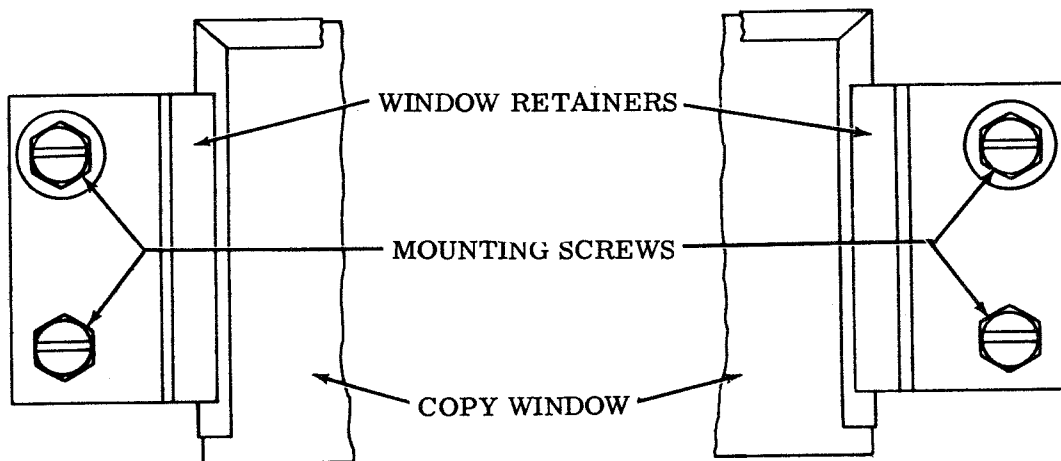

(BOTTOM VIEW)

2.06 Signal Bell and Cradle

(A) ARMATURE SPRING TENSION

Requirement

Min 1/2 oz---Max 1 oz
to push the armature against the core
(vertically).

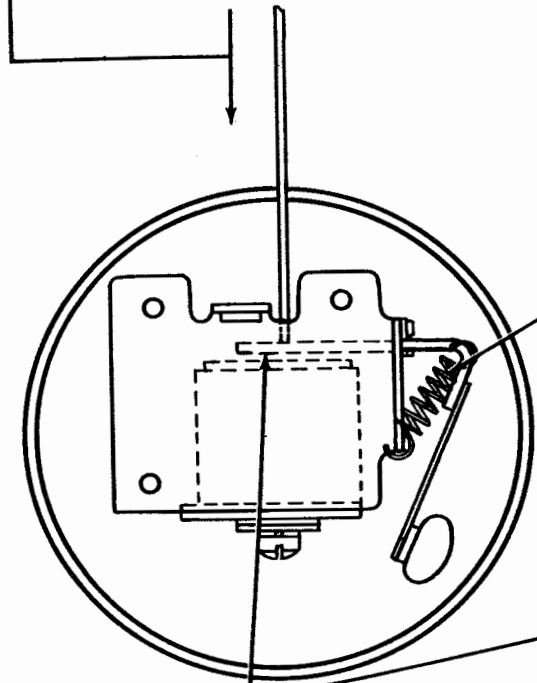

(B) REMOTE SIGNAL BELL

Requirement

Armature held against the magnet
core. Clearance between the
armature ball and the bell
Min 0.020 inch---Max 0.035 inch

To Adjust
Bend the armature extension just
below the armature spring.

ARMATURE SPRING

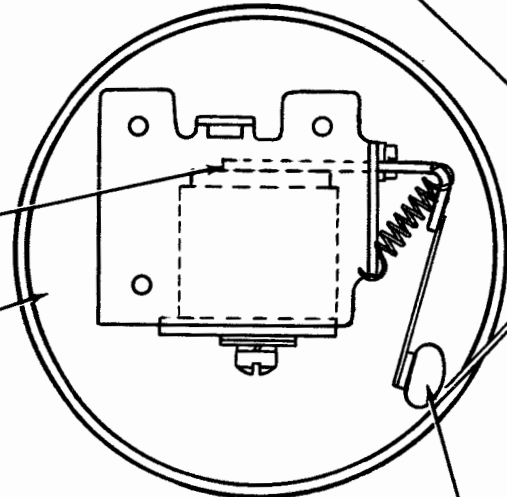

(C) CRADLE

Requirement

Top of hinge bracket parallel to top of hinge bar.

To Adjust

Turn stop screw with locknut loosened.

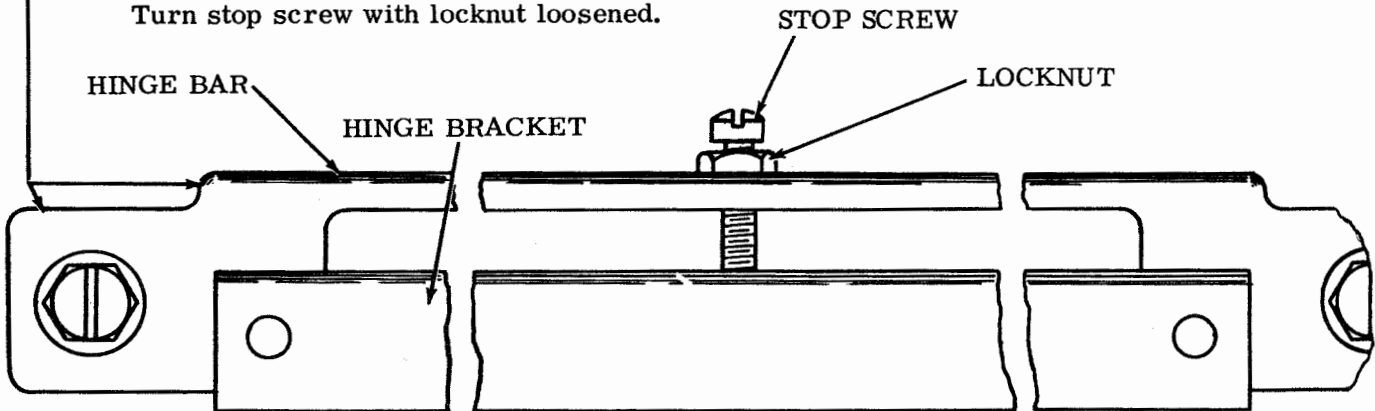

2.07 End-Of-Form Alarm Mechanism and Low-Paper and Paper-Out Switch Assembly

END-OF-FORM LEVER

Requirement

End-of-form lever should move freely between typing unit and paper guide on the cabinet. Check with dome closed and small door open.

To Adjust

Position end-of-form lever forward or backward with its clamp screws loosened and up or down with end-of-form assembly mounting screws loosened.

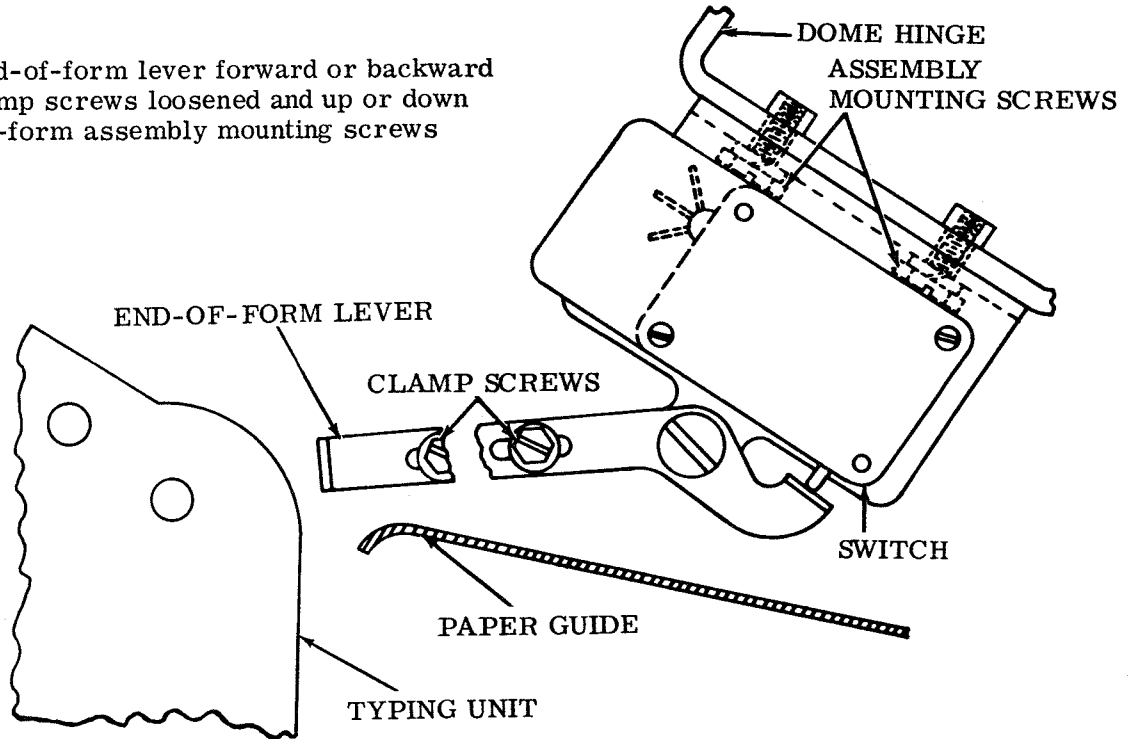

LOW-PAPER AND PAPER-OUT SPRING

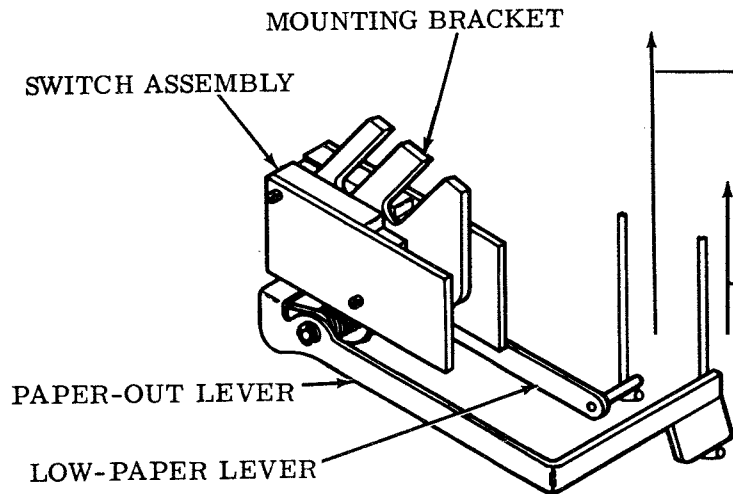

Requirement

Min 1/4 oz---Max 1-1/2 oz to pull the low-paper and paper-out levers up to point where switches operate.

2.08 Off-Set Copyholder

MOUNTING SCREWS

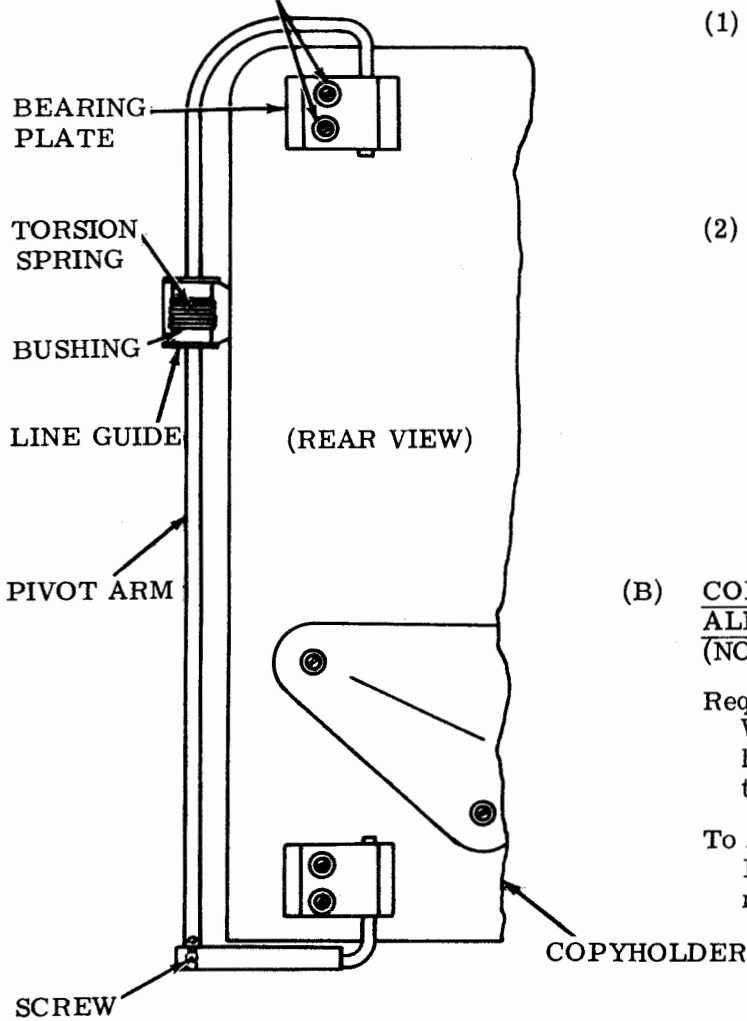

(A) PIVOT ARM AND LINE GUIDE

(1) Requirement

There should be sufficient tension on the pivot arm to hold it in the desired position.

To Adjust

Tighten the bearing plate mounting screws. (Remove shims, if present.)

(2) Requirement

There should be sufficient tension on the line guide to prevent it from slipping down its pivot arm.

To Adjust

Remove the lower bearing plate. Remove the screw from the bottom of the pivot arm. Slip the line guide off the pivot arm. Rotate the bushing in the line guide to increase the tension of the torsion spring. Reassemble.

(B) COPYHOLDER BRACKET AND TOP BRACKET ALIGNMENT ON TABLE MOUNTED CABINET (NOT ILLUSTRATED)

Requirement

With lower bracket in forward position, the hole in the top bracket should align with the top hole in copyholder bracket.

To Adjust

Position lower bracket along its elongated mounting holes by means of its two nuts.

2.09 Directory Holder (TWX)

DIRECTORY HOLDER (TABLE CABINET)

Requirement

The directory holder should fit snugly against the wall of the cabinet.

To Adjust

Loosen the four bottom inner set of nuts which secure the shock mounts and the holder. Push the holder against the wall of the cabinet and tighten the nuts.

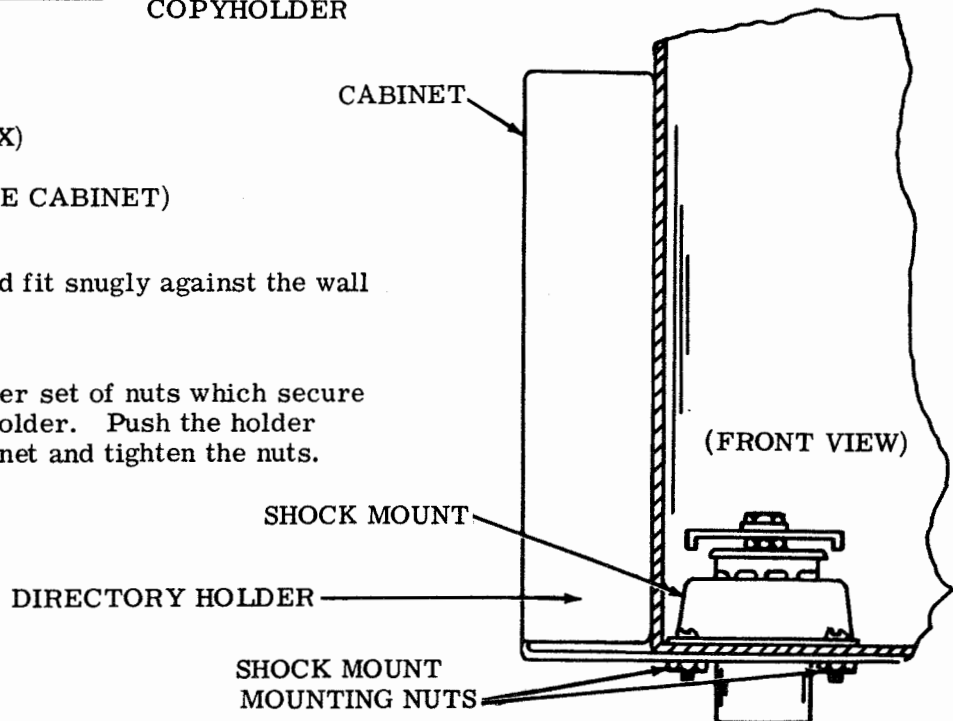

EBAC — 28 LA Teletypewriter Cabinets

2.10 Printer Cover

Note: Rest cabinet on a level floor when making the following adjustments.

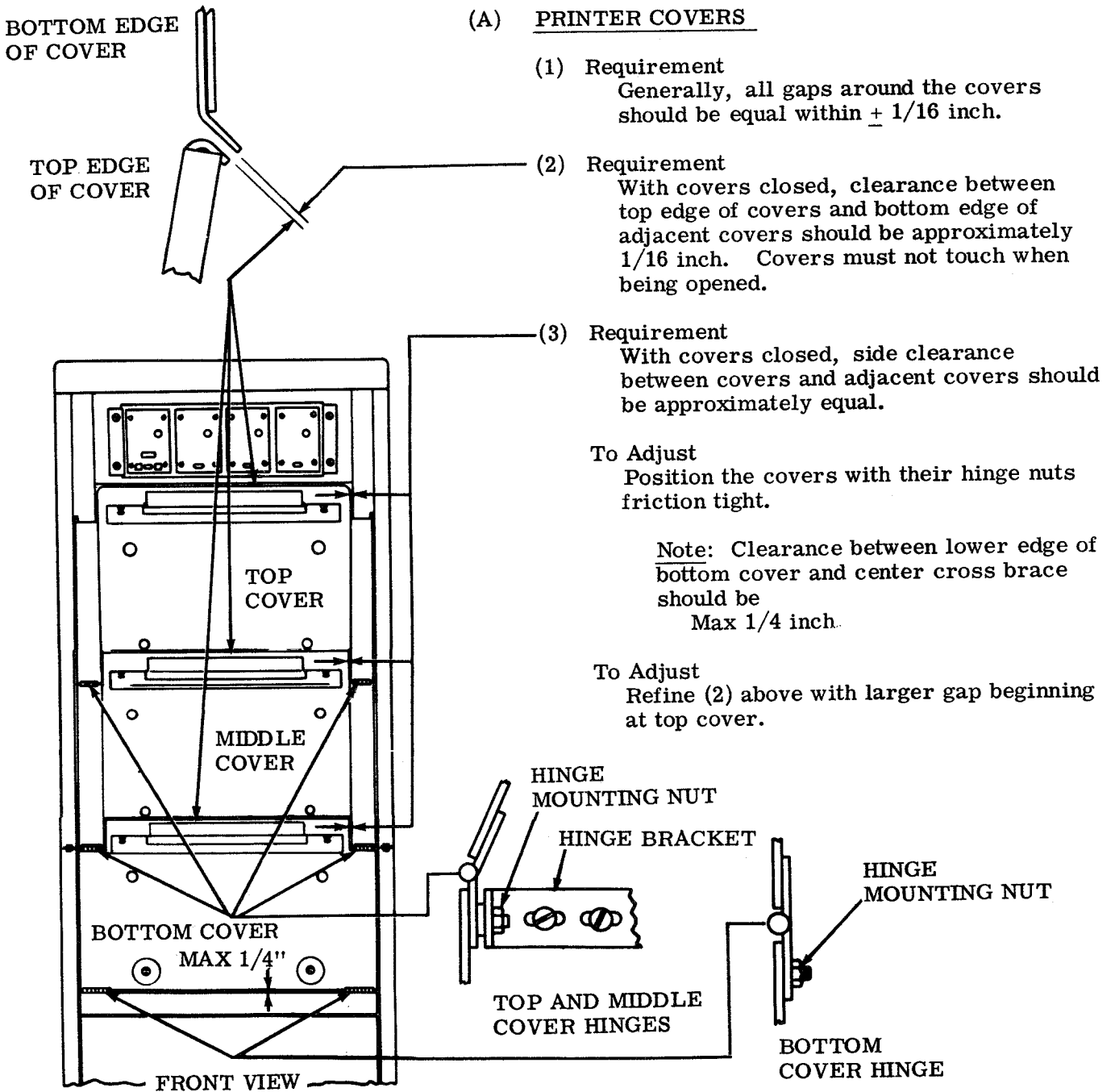

2.11 Printer Cover continued

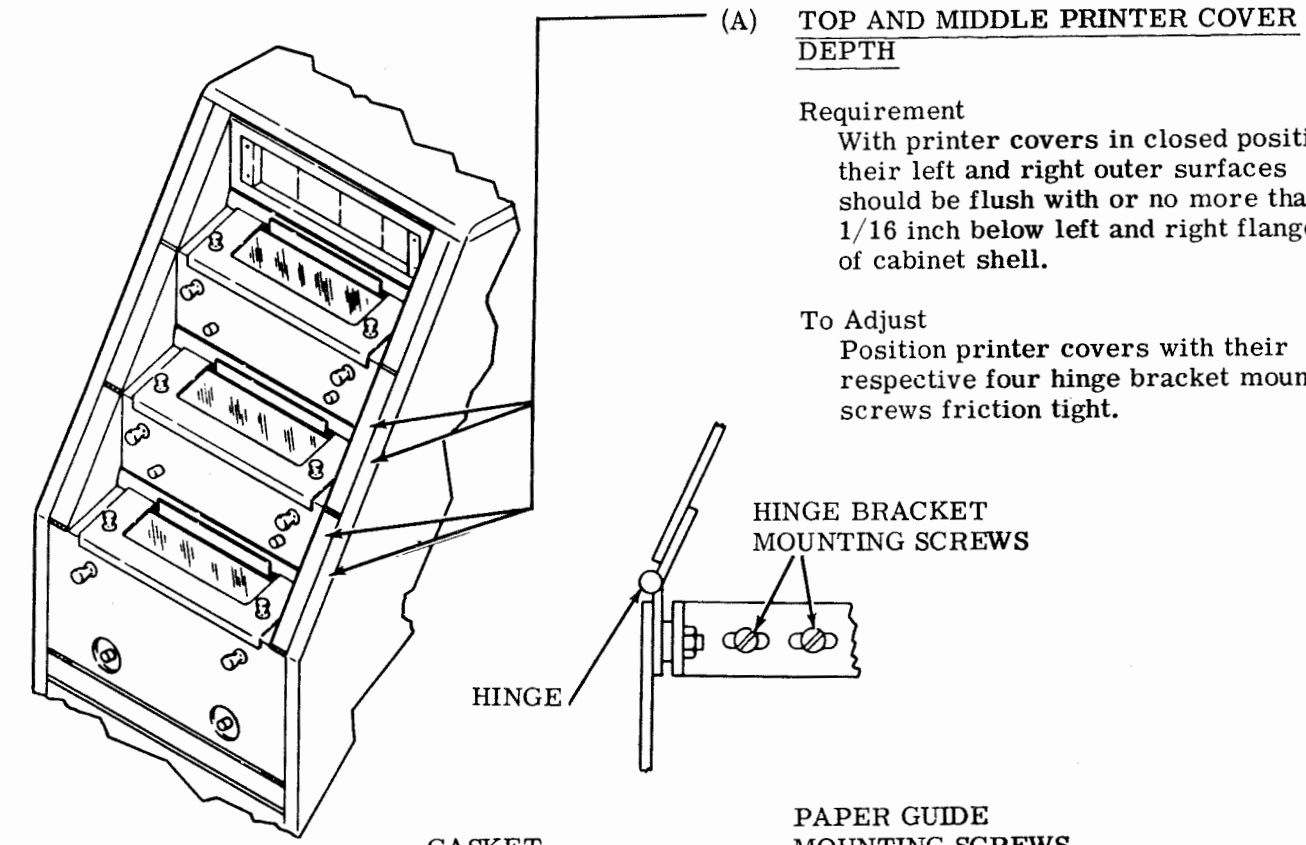

Requirement
With printer covers in closed position, their left and right outer surfaces should be flush with or no more than 1/16 inch below left and right flanges of cabinet shell.

To Adjust
Position printer covers with their respective four hinge bracket mounting screws friction tight.

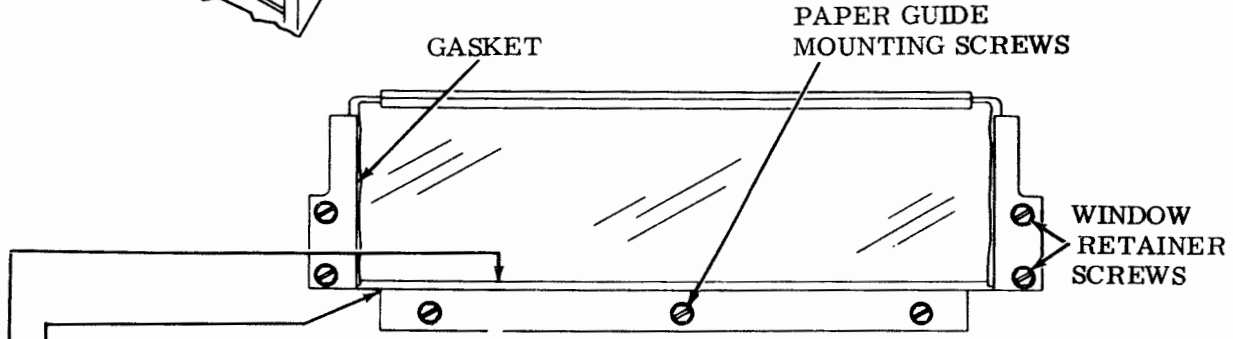

(B) PAPER GUIDE

Requirement
Bottom edge of paper guide should be flush with bottom surface of window.

To Adjust
Position paper guide with three mounting screws loosened.

(C) WINDOW

Requirement
Clearance between paper and paper guide when closing the paper access door should be
Min 1/16 inch

To Adjust
Position window with four window retainer screws loosened. **Make sure** gasket is between glass window and metal surface.

2.12 Cover Latches

PRINTER COVER LATCHES

- (1) Requirement
With cover in closed position, bolts should touch striker plates.
- (2) Requirement
Bolts should engage striker plates by a minimum of 1/16 inch.

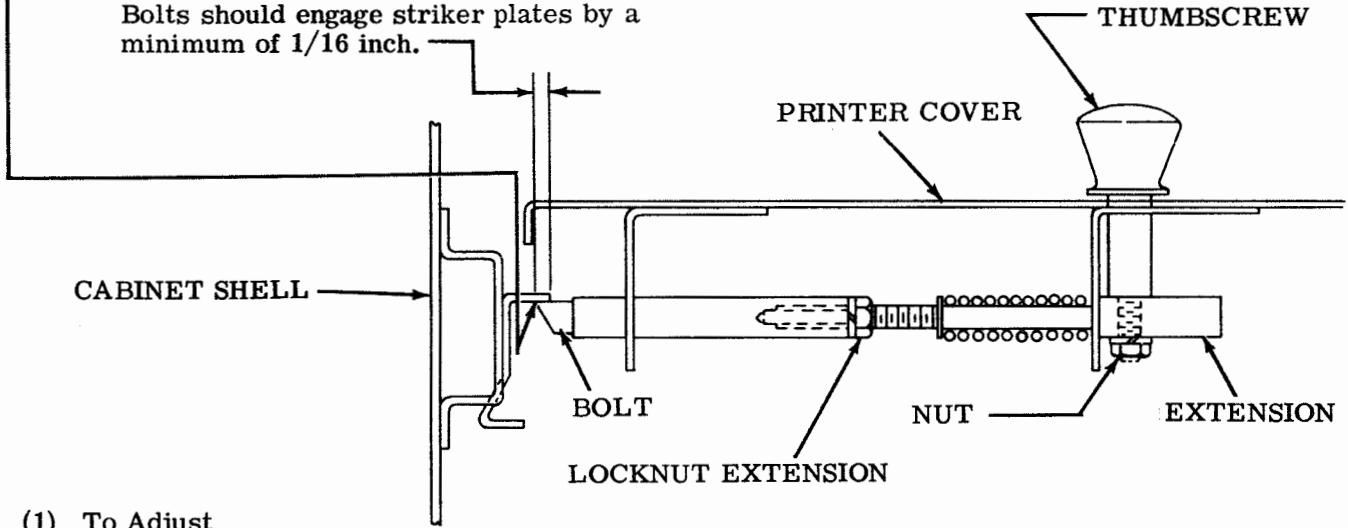

MIDDLE AND TOP COVER LATCHES

- (1) To Adjust
With cover open and striker plate mounting screws friction tight, move striker plates toward front of cabinet. Close cover and open paper access door. Position striker plates to meet (1) above. Close paper access door. Carefully move printer cover thumbscrews toward each other and open printer cover. Tighten striker plate mounting screws.

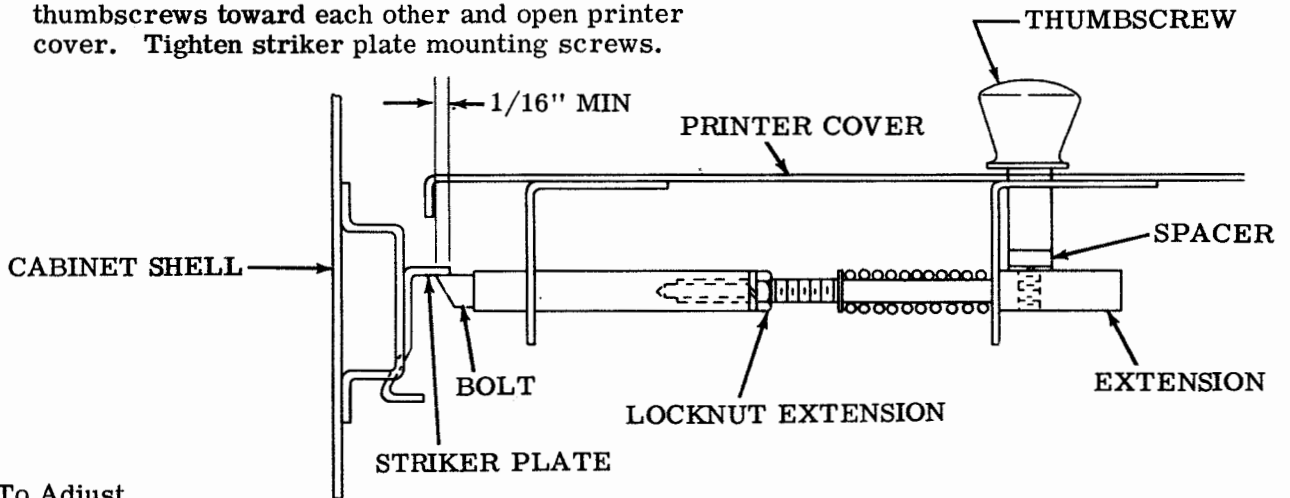

LOWER COVER LATCHES

- (2) To Adjust
Close cover and open paper access door. Remove cover thumbscrews and their lockwashers from extensions. With their locknuts loose, rotate extensions to move bolts right or left as required. Align tapped hole in extension with hole in cover. Replace thumbscrews and lockwashers. Tighten extension locknuts.

2.13 Shelf Slide Stops

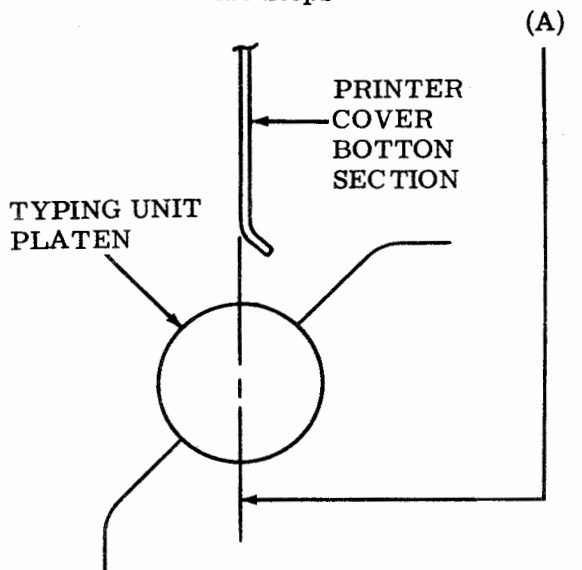

(1) Requirement

With each printer unit in rearmost position, center of typing unit platen should be in line with front edge, plus or minus 1/16 inch, of printer cover above it for the upper two typing units.

(2) Requirement

Center of platen of bottom typing unit should be in line with front edge of cover above it within 1/16 inch forward - 3/16 inch rearward.

To Adjust

(1), (2): Open cover and loosen slide mounting screws friction tight. Position slide, base and typing unit to meet requirement.

Note: This adjustment affects carriage return and line feed lever adjustments. Therefore, if slide stops are readjusted, carriage return and line feed levers should also be re-adjusted.

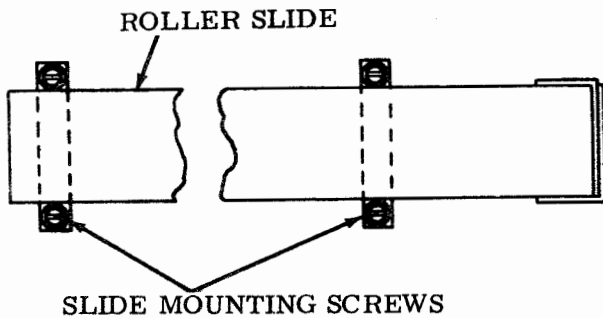

(B) CARRIAGE RETURN AND LINE FEED LEVERS

Requirement (each printer cover)

With printer cover closed

Min 3/32 inch---Max 5/32 inch clearance between head of lever adjusting screw and rear surface of key-lever mounting bracket.

To Adjust

Depress keylever assembly and rotate it 90 degrees. Remove keylever assembly and keylever spring. Close cover and turn lever adjusting screw, accessible through hole in cover, to meet requirement.

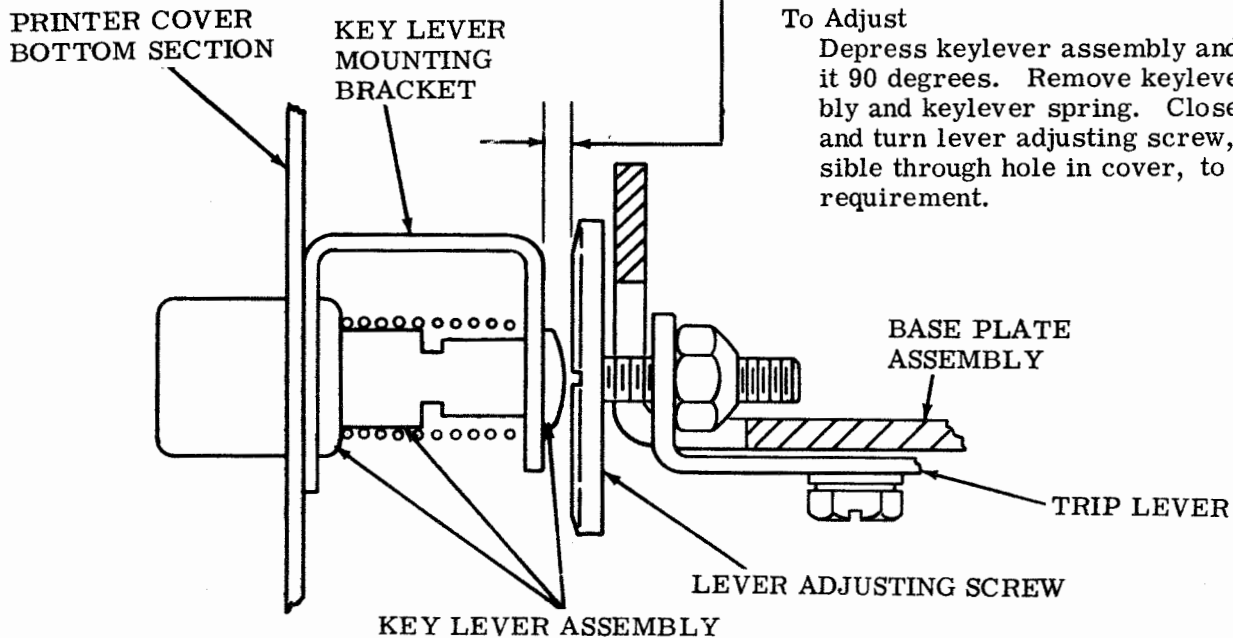

2.14 Paper Winder

(C) PAPER SPINDLE CYLINDER REGULATING BUSHING

To control the tension of the cylinder on the right hub, position regulating bushing to the right or left with its set screw loosened.

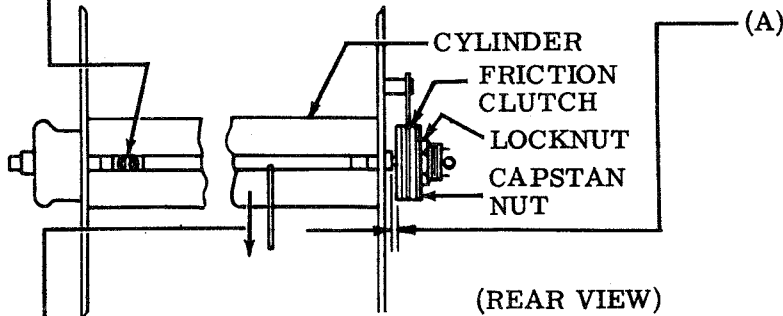

(A) PAPER SPINDLE SHAFT ENDPLAY

Requirement

Clearance between shoulder of shaft and friction drive assembly should be 1/32 inch. Left end of shaft should touch wick in friction drive assembly.

To Adjust

Position bearing bracket by means of elongated mounting holes.

(B) FRICTION CLUTCH TORQUE

Requirement

After running paper winder ten minutes with cylinder held stationary it should require
 Min 5 ozs---Max 7 ozs
 to hold cylinder stationary against rotation by driven pulley.

To Adjust

Position capstan nut with locknut loosened.

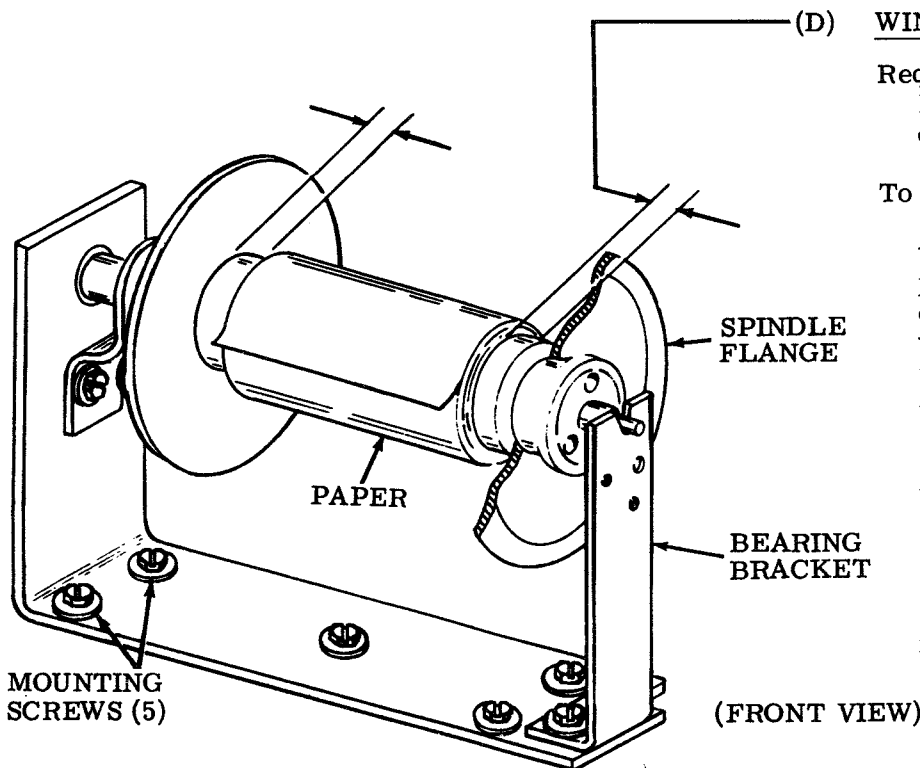

(D) WINDER ASSEMBLY

Requirement

Equal clearance between edges of paper and spindle flanges.

To Adjust

Thread paper around platen of typing unit. Grasp edges of paper as it comes around top of platen roller and align them with edges of paper being fed into platen. Pull top free edge of paper so there is no slack and lock paper on platen. Feed paper manually until it can be threaded onto winder cylinder. Move winder assembly with its mounting screws loosened to get equal clearance between both edges of paper and spindle flanges.

2.15 Paper Winder continued

(A) PULLEY ALIGNMENT

Requirement

Projected plane of each pulley should be in line with each other and parallel to side frame.

To Adjust

Loosen driver pulley adjusting screw. Move in or out to meet requirement. Tighten screw.

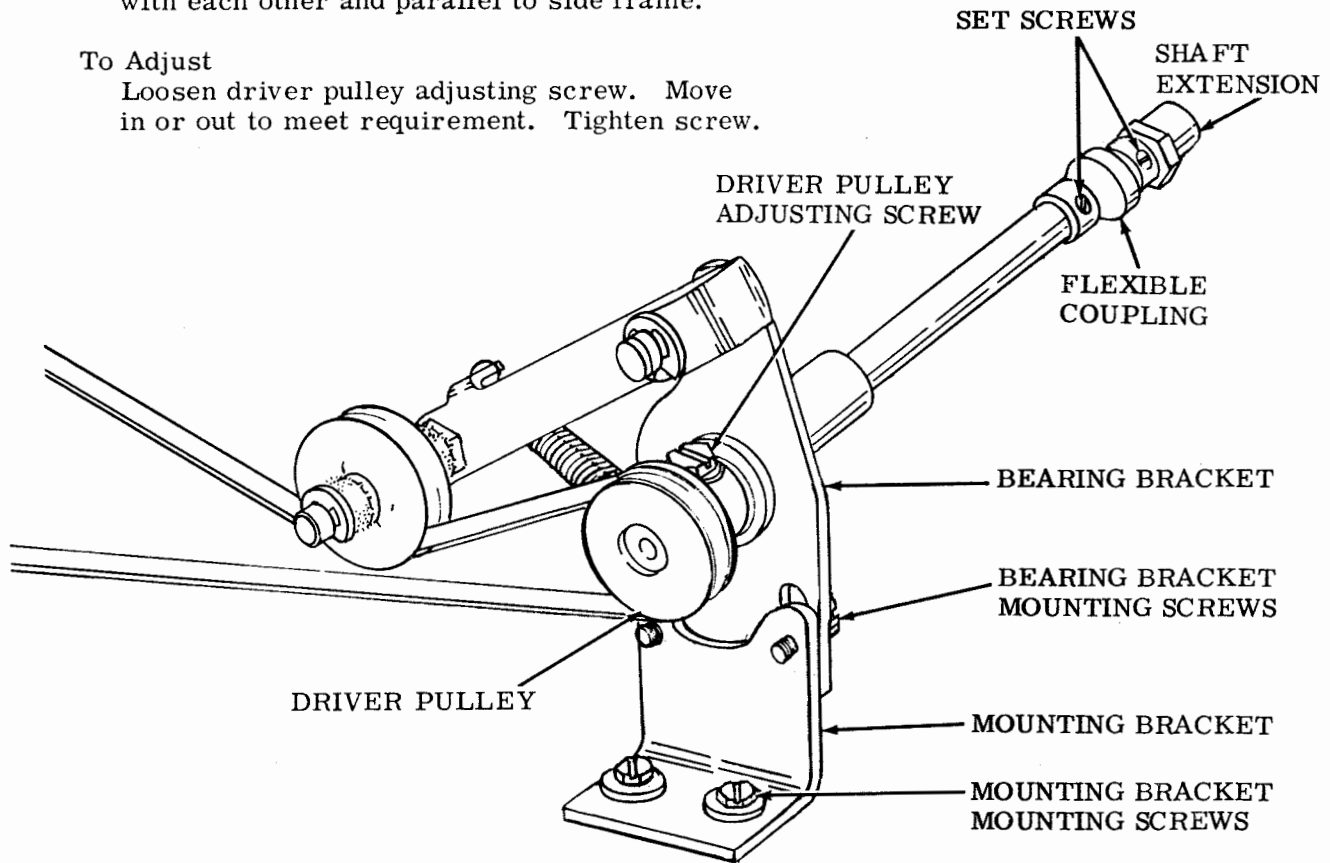
(B) BEARING BRACKET ADJUSTMENT

Note: The intermediate gear bracket adjustment should be made before making this adjustment. See appropriate section covering adjustments for keyboard and base.

Requirement

Bearing bracket should be position so that center line of intermediate shaft extension will coincide with center line of intermediate shaft in both horizontal and vertical planes.

To Adjust

- (1) Horizontal - Loosen mounting bracket screws to friction tight. Loosen set screws in flexible coupling and slide coupling toward pulley end of shaft so opposite end of shaft is visible. Position bracket to align shaft extension with intermediate shaft on keyboard base.
- (2) Vertical - Loosen bearing bracket mounting screws to friction tight. Position bearing bracket to align shaft extension with intermediate shaft on keyboard base. Retighten screws. Connect shaft and shaft extension by replacing and fastening flexible coupling in position.

LPC (Skintight) — 28A Teletypewriter Cabinets

2.16 Dome

(A) DOME CENTERING

(1) Requirement

The dome should be centered from side to side on the cabinet.

(2) Requirement

Front edge of dome should fit flush to front edge of cabinet.

To Adjust

Position the dome with the six dome hinge nuts loosened.

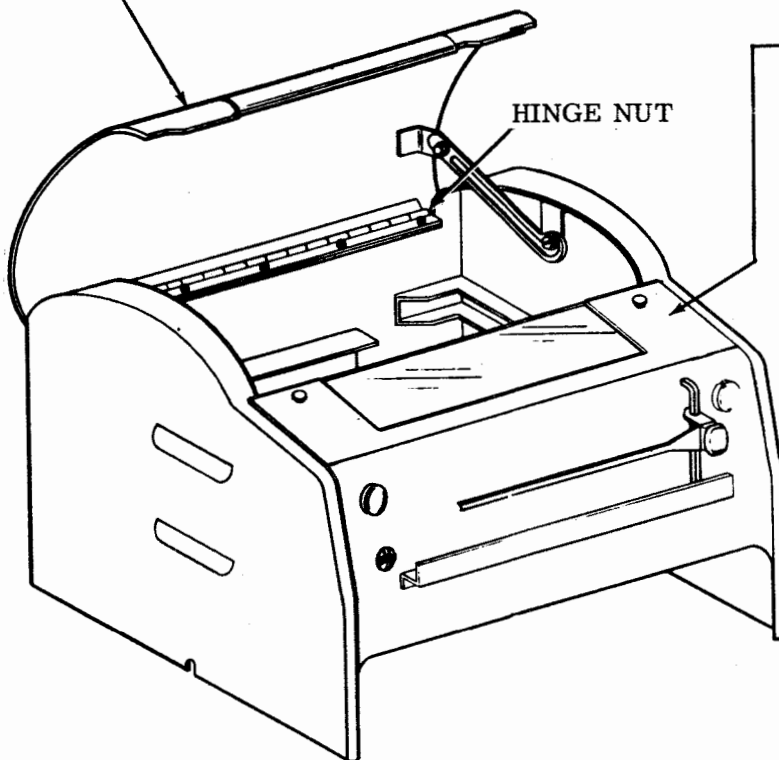
(B) SMALL DOOR

(1) Requirement

Door should be flush with to $3/32$ inch above dome.

(2) Requirement

Door should be parallel to dome within $3/32$ inch.

To Adjust

Position door with the four hinge extension nuts loosened.

For the following adjustments see Par. 2.03.

(C) PAPER GUIDE

*(D) WINDOW - Refer to requirement below and Par. 2.03.

(E) INDICATOR AND COPY LAMPS(F) COPYHOLDER*(D) WINDOW (Also see Par. 2.03)

Requirement

As small door is opened, it should clear projection on rear lid by
Min 0.005 inch---Max 0.015 inch

To Adjust

Position the window with its mounting screws (4) loosened.

LPC (Multiple Mount) — 28L and 28M Teletypewriter Cabinets

2.17 Hinge Mount

WALL MOUNTED PRINTER CABINET

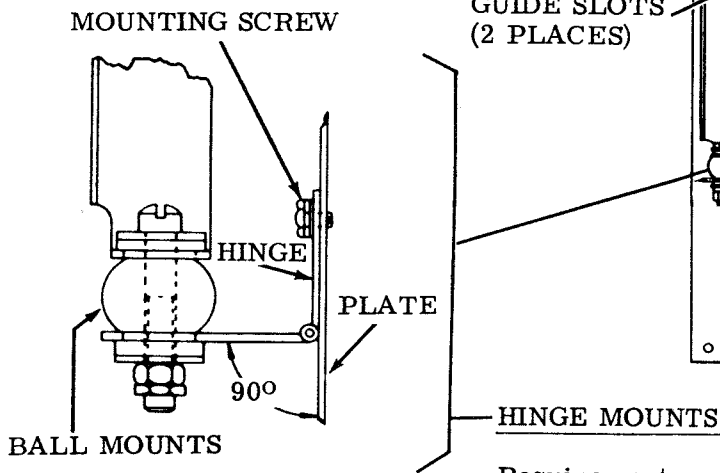
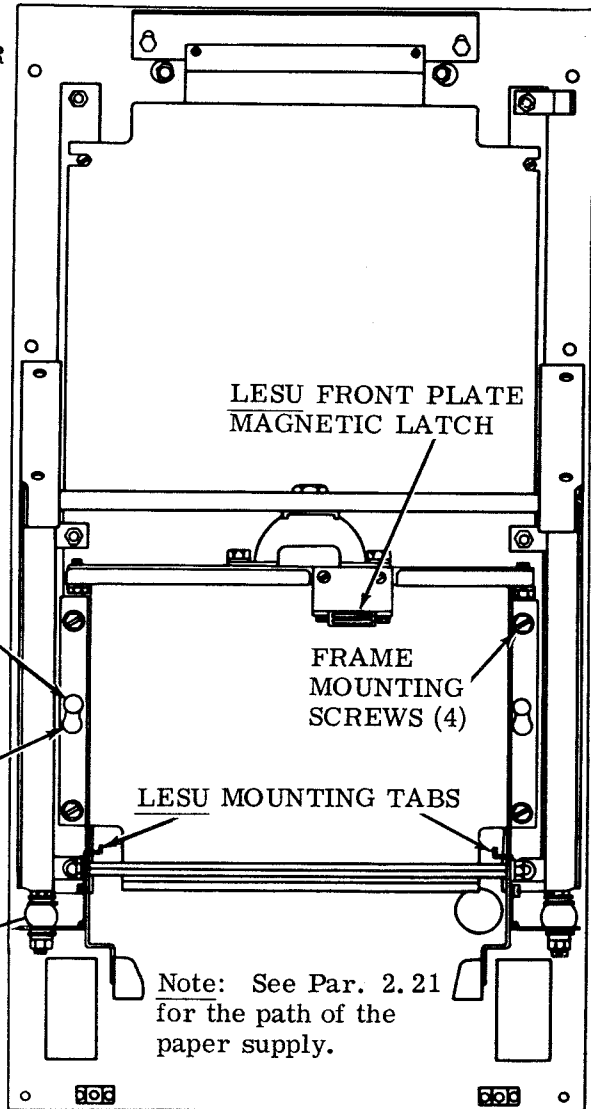
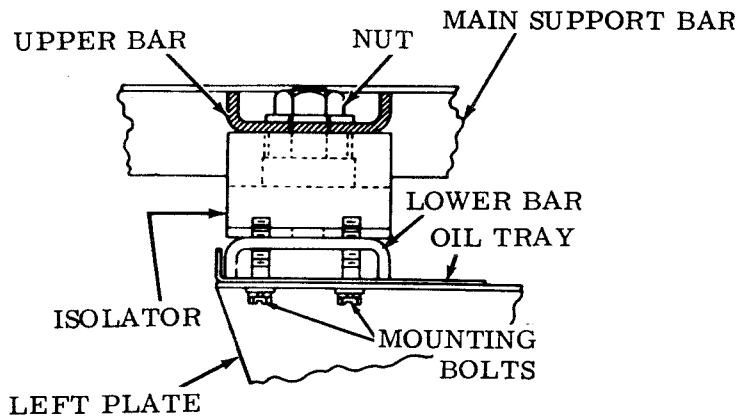

Requirement

With keyboard (or receiving-only base), printer and motor unit installed, the hinge shall be perpendicular to side plate - gauge by eye. Check both sides.

To Adjust

Position right and/or left hinge upward or downward with its mounting screws loosened.

2.18 Keytop Guide Plate

KEYTOP GUIDE PLATE COVER (SEND-RECEIVE UNIT)

Requirement

With cover installed, clearance between keytop guide plate and its cover
 Min 0.090 inch---Max 0.125 inch

To Adjust

With nuts that secure cover mounting bar loosened, lower screws and eccentric clamp screws loosened, position eccentric.

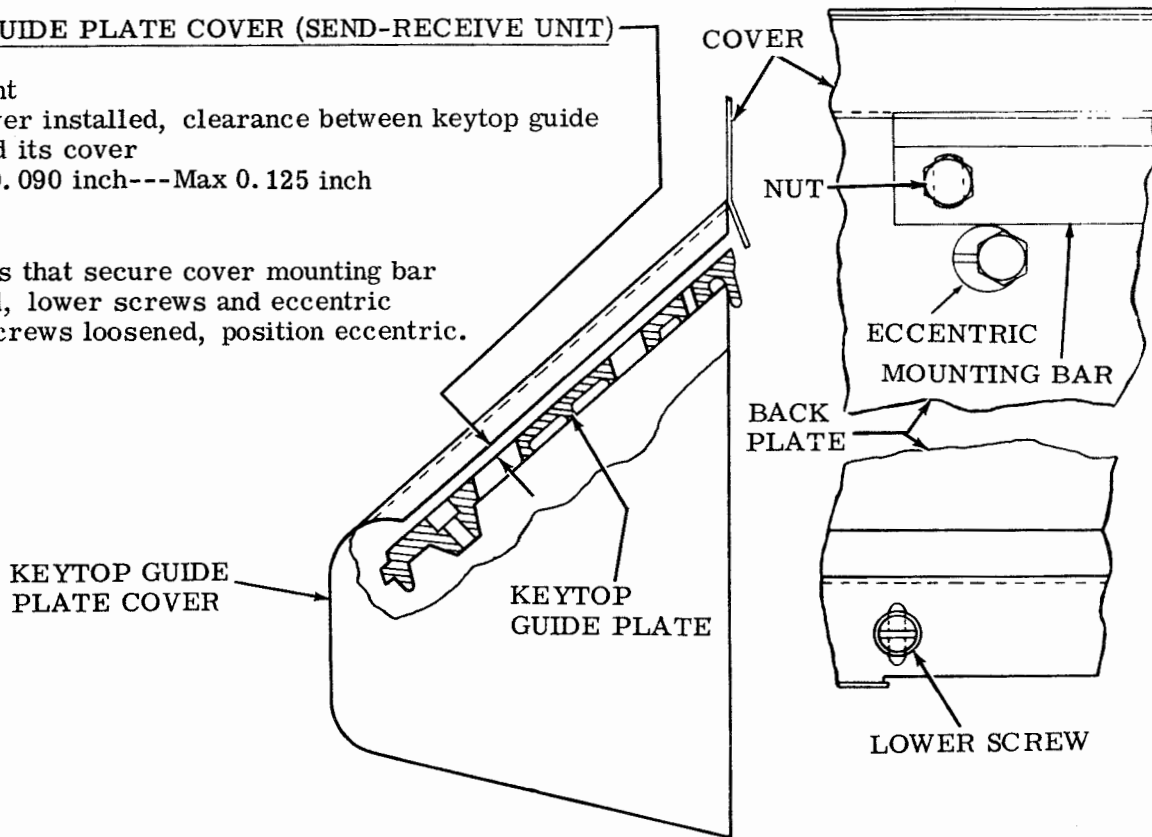

KEYTOP COVER (RECEIVE-ONLY UNIT)

Requirement

With cover in place, power switch shall be centrally located in its cover opening.

To Adjust

With nuts that secure cover mounting bar loosened, lower screws and eccentric clamp screws loosened, position eccentric.

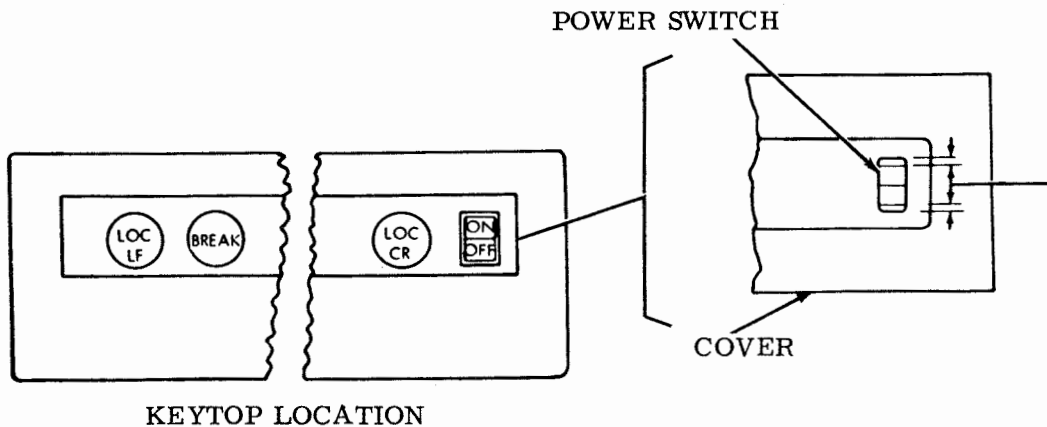

2. 19 Keytop Guide Plate continued

KEYTOP GUIDE AND COVER (SEND-RECEIVE UNITS)

(1) Requirement
 With cover in place, clearance between rear edge of keytop guide and lip of cover
 Min 0.090 inch---Max 0.0125 inch

(2) Requirement
 Clearance should be approximately equal at each end.

(1) To Adjust
 With nut which secures large central mount loosened, position upper support bar.

(2) To Adjust
 With four bolts that secure lower support bar loosened, position lower support bar.

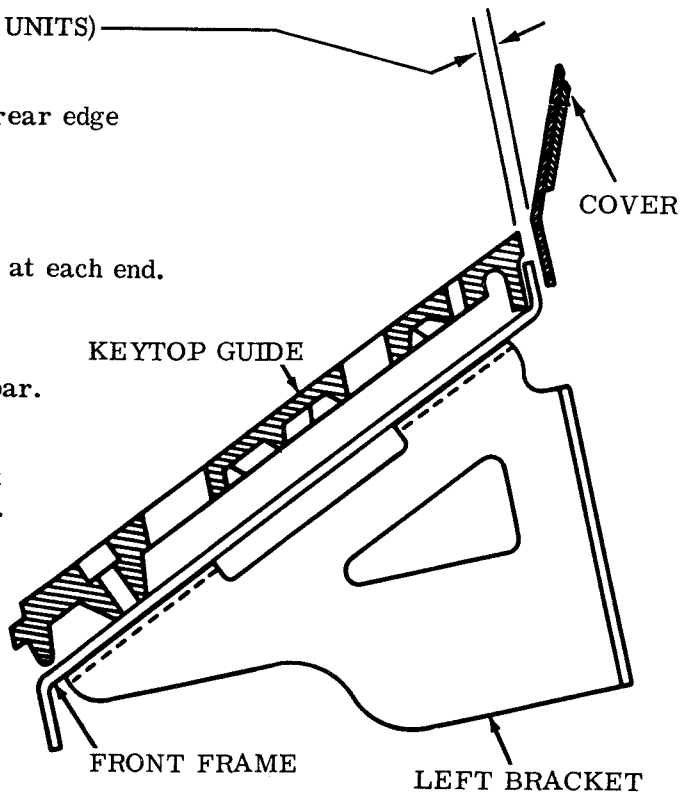

POWER SWITCH

Requirement
 With cover panel in place, surface of switch toggle lever (1) in ON position (2) in OFF position should be flush with top surface of cover (gauge by eye).

To Adjust
 With cover removed, position switch with its adjusting screws loosened.

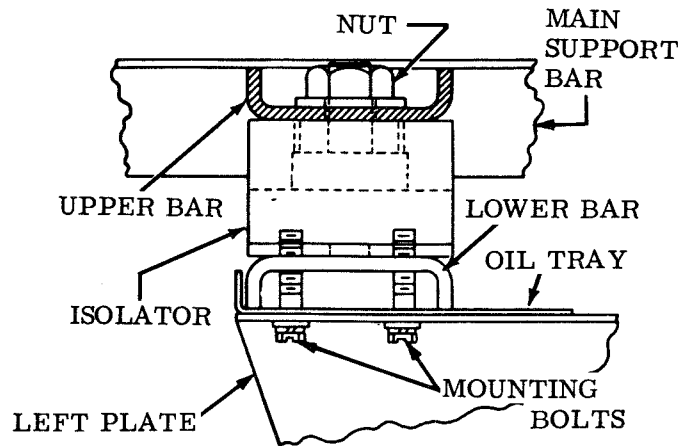
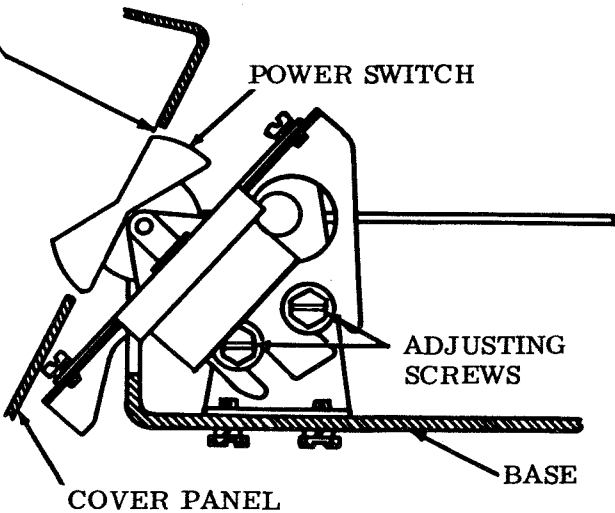

Note: Should additional adjustment be needed, loosen bolts securing large central mounting bracket, and position upper bar.

2.20 Carriage Return, Line Feed, Break Lever and Door Hinge

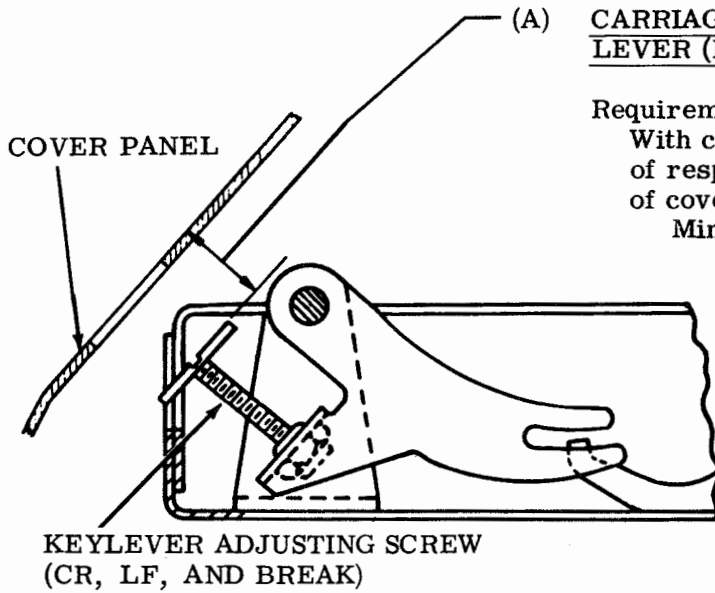

(A) CARRIAGE RETURN/LINE FEED/ AND BREAK LEVER (RECEIVE-ONLY UNIT)

Requirement

With cover in place, clearance between top surface of respective lever adjusting screw and outer surface of cover

Min 7/8 inch---Max 15/16 inch

To Adjust

Remove each keylever assembly (3) from cover (see Par. 2.18). Then replace cover and position each adjusting screw through hole in cover (slot in screw should be horizontal after adjusting).

REMOVE KEYLEVER ASSEMBLY (2 NUTS, LOCKWASHER AND FLAT WASHER).

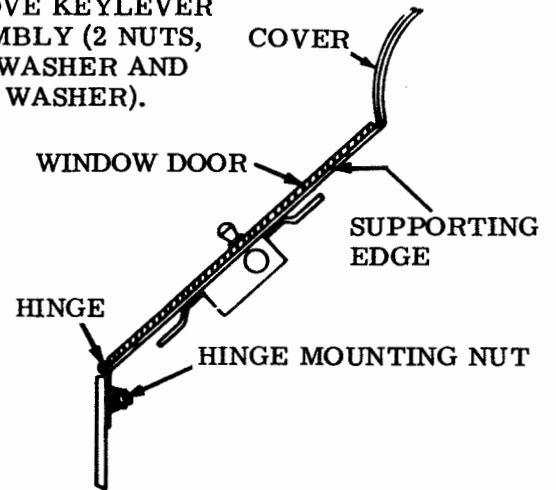

(B) WINDOW DOOR HINGE MOUNTS

Requirement

Window door should lie flat on right and left supporting edge of cabinet (gauge by eye).

To Adjust

With hinge mounting nuts (2) loosened, position the door.

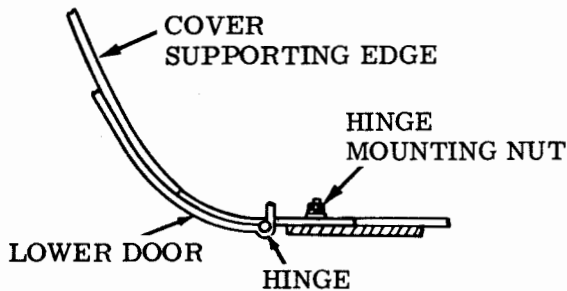

(C) LOWER DOOR HINGE MOUNTS

Requirement

Door should lie flat against cover.

To Adjust

With each hinge mounting nut (2) loosened, position the door.

(D) LOWER DOOR LATCHES

Requirement

Door should latch firmly and lie flat against cover.

To Adjust

With magnetic latch mounting screws loosened, position the latch.

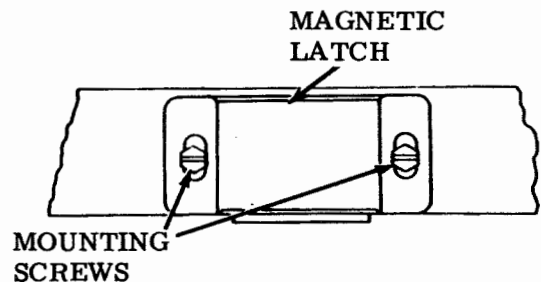

SMALL COPYHOLDER (WITH LINE GUIDE)

Requirement — Refer to Par. 2.03.

2.21 Window and Paper Guide

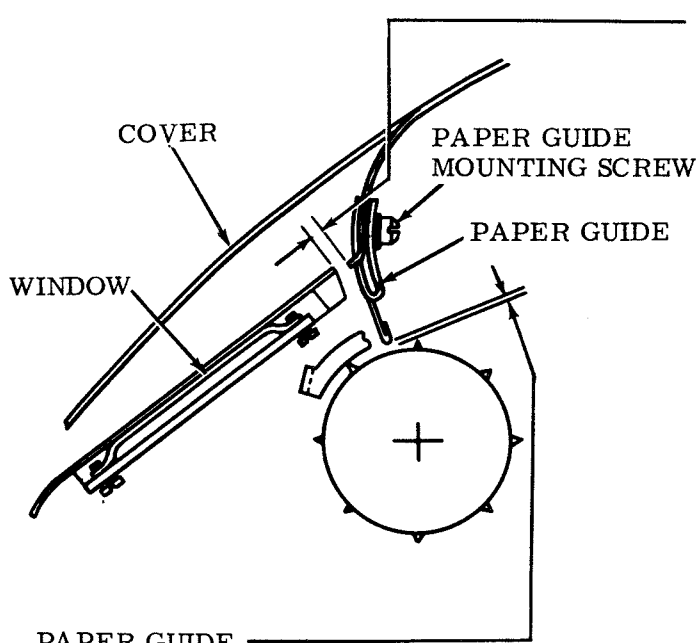

(A) PAPER GUIDE

Requirement

With typing unit in place, large and small doors latched, clearance between paper guide and platen

Min 3/64 inch---Max 5/64 inch

To Adjust

With paper guide mounting screws loosened, position guide parallel to platen.

(B) WINDOW

Requirement

With small door closed, parallel clearance between paper guide and edge of window

Min 0.080 inch---Max 0.110 inch

To Adjust

With window clamp mounting screws loosened (4), position the window.

PATH OF PAPER

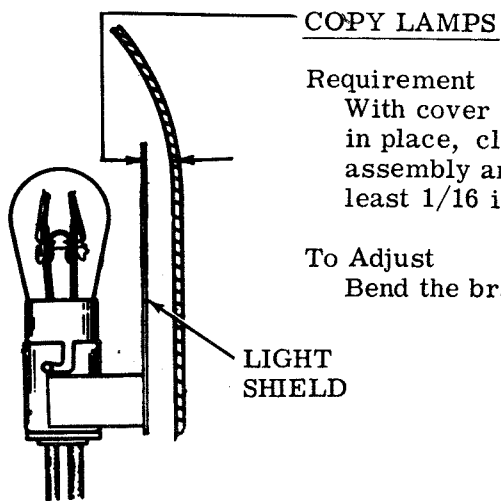
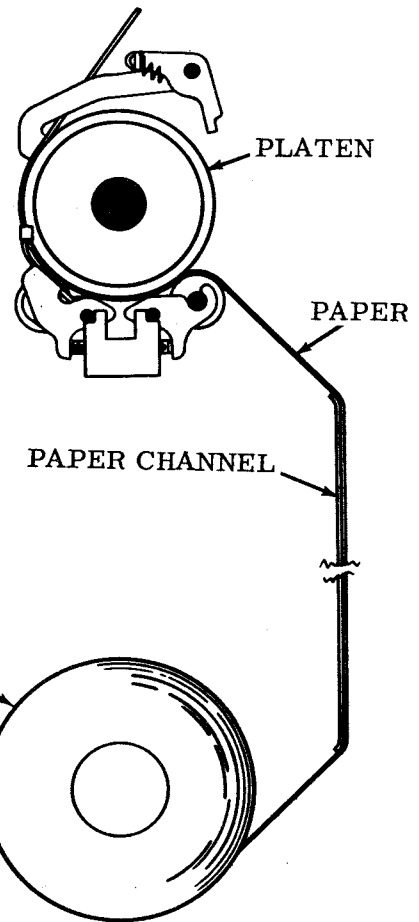

Requirement

With cover and light shield in place, clearance between lamp assembly and cover should be at least 1/16 inch.

To Adjust

Bend the bracket.