

28 TYPING REPERFORATOR AND TAPE PRINTER

LUBRICATION

CONTENTS	PAGE	CONTENTS	PAGE
1. GENERAL	1	End of tape feed-out timing con- tacts for noninterfering LTRS and BLANK tape feed-out mechanisms . .	29
2. BASIC UNITS	2	Letters-figures contact mechanism (later design)	34
Axial positioning mechanism	13, 14	Manual and power drive backspace mechanisms (for chadless tape)	36
Detent assemblies	14	Manual and solenoid operated interfering LTRS tape feed-out mechanisms	21, 22
Function box mechanism	13	Print suppression on functions	31
Function cam clutch trip mechanism .	17	Remote control noninterfering LTRS and BLANK tape feed-out mechanisms	25
Main shaft and jack shaft mechanisms (two shaft unit)	18	Signal bell contact mechanism	20, 21
Main shaft mechanism	10	Time delay motor stop mechanism . .	39
Printing mechanism	15	Timing contacts	35
Punch mechanism (for chadless tape).	4, 5	Timing contact mechanism (operated by selector)	30
Punch mechanism (for fully perfor- ated tape)	6, 7	Unshift-on-space mechanism	20
Push bars	11		
Range finder mechanism	10	4. EARLIER DESIGN MECHANISMS . . .	40
Ribbon feed mechanism (later design)	3	Remote control noninterfering BLANK tape feed-out mechanism . .	41-46
Rocker bail mechanism	16	Ribbon feed mechanism	40
Rotary positioning mechanism	9	Timing contacts	46
Selector mechanism	9		
Signal bell contact mechanism	17	1. GENERAL	
Slack tape mechanism (for 28 tape printer unit)	19	1.01 This section contains the lubrication pro- cedures for the 28 typing reperforator and tapeprinter units. The section has been revised to include recent engineering changes and addi- tions and to rearrange the text, so as to bring the section generally up-to-date. Since this is an extensive revision, marginal arrows ordinari- ly used to indicate changes have been omitted.	
Transfer mechanism	11	1.02 The figures indicate points to be lubri- cated and the kind and quantity of lubri- cant to be used. Lubricate the units just prior to placing them in service. After a few weeks in service, relubricate to make certain that all points receive lubrication. The following lubri- cation schedule should be followed thereafter:	
Typing reperforator unit	2, 8, 12		
3. VARIABLE FEATURES	20		
Automatic and remote control non- interfering BLANK tape feed-out mechanisms	28		
Automatic and remote control non- interfering LTRS and BLANK tape feed-out mechanisms	24, 26, 27		
Automatic and remote control non- interfering LTRS tape feed-out mechanisms	23		
Backspace mechanism for chadless tape (manual)	37		
Backspace mechanism for chadless tape (power drive)	37		
Backspace mechanism for fully perforated tape (power drive)	38		
Blank delete mechanism	32, 33		
Code reading contacts	35		

OPERATING SPEEDS
IN WORDS PER MINUTE

60
75
100

LUBRICATION
INTERVAL

3000 hours
or 1 year*
2400 hours
or 9 months*
1500 hours
or 6 months*

*Whichever occurs first.

1.03 Use TP88970 (KS7470) oil at all locations where the use of oil is indicated. Use TP88973 (KS7471) grease on all surfaces where grease is indicated. If the function cam needle bearings are disassembled at any time, repack the bearings with TP195298 grease (Beacon 325 grease or its equivalent).

1.04 All spring wicks and felt oilers should be saturated. The friction surfaces of all moving parts should be thoroughly lubricated. Over lubrication, however, which will permit oil or grease to drip or be thrown on other parts, should be avoided. Take special care to prevent oil or grease from getting between armatures and pole faces or between electrical contact

points. Pull a piece of "BOND" paper between the armature and the pole pieces to remove any oil or foreign matter that may be present. Make certain that no lint or pieces of paper remain between the pole pieces and armature.

1.05 Apply a thick film of grease to all gears.

1.06 Apply oil to all cams, including the camming surfaces of each clutch disc.

1.07 The photographs show the paragraph numbers referring to particular line drawings of mechanisms and where these mechanisms are located on the unit. Parts in the line drawings are shown in an upright position unless otherwise specified.

1.08 The illustration symbols indicate the following lubrication directions:

- O1 Apply 1 drop of oil.
- O2 Apply 2 drops of oil.
- O3 Apply 3 drops of oil, etc.
- G Apply thin film of grease.
- SAT Saturate (felt oilers, washers, wicks) with oil.

2. BASIC UNITS

2.01 Typing Reperforator Unit

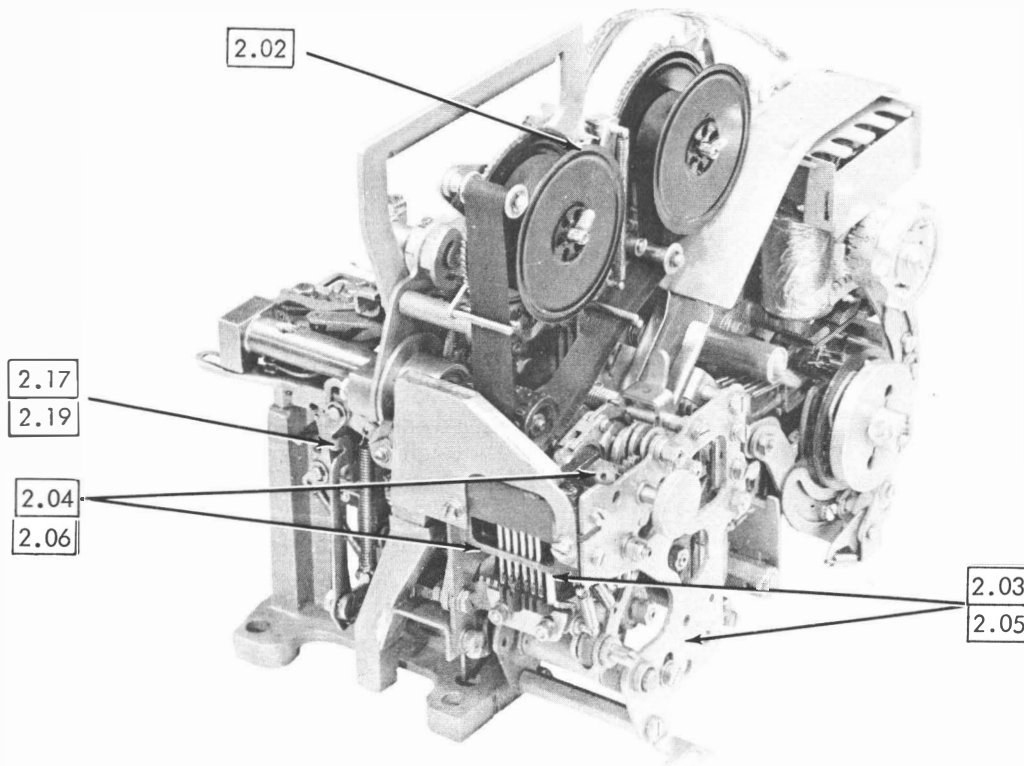

2.02 Ribbon Feed Mechanism (Later Design)

(For Earlier Design
See Part 4.)

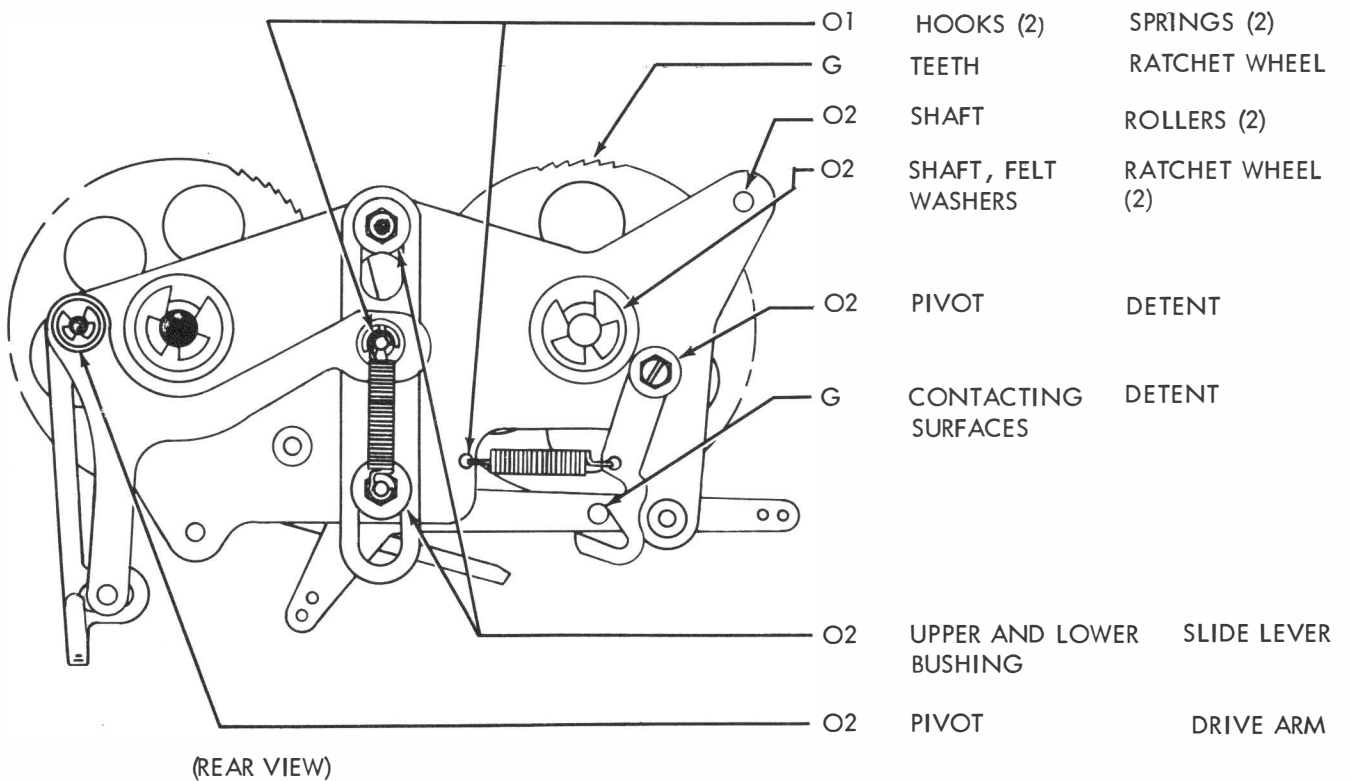
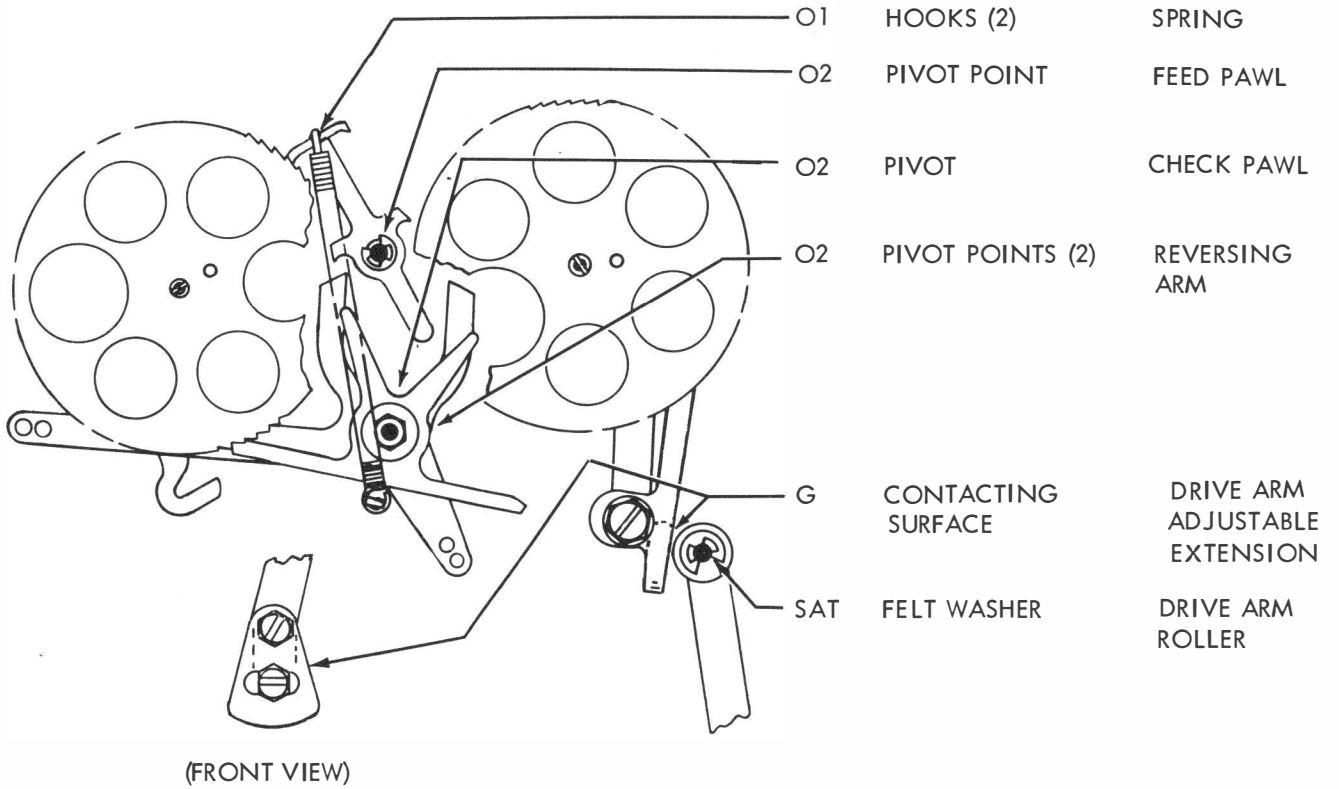

2.03 Punch Mechanism for Chadless Tape

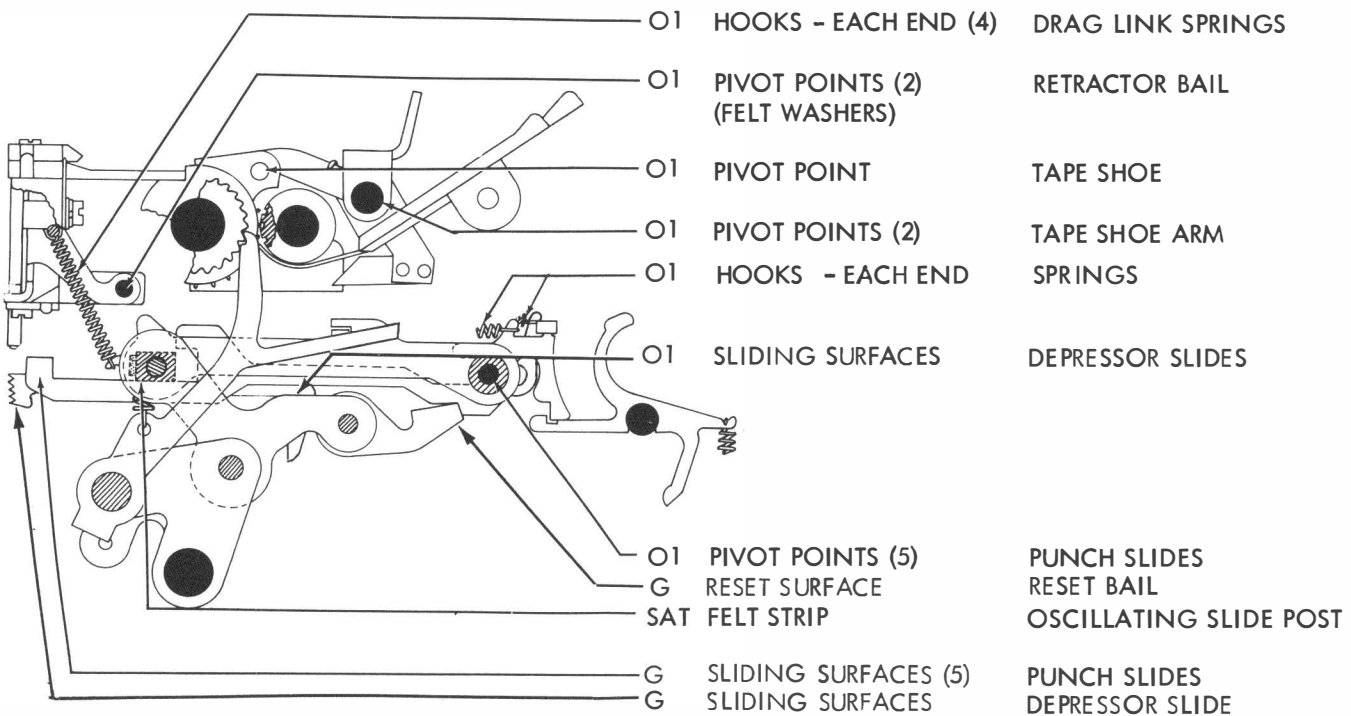
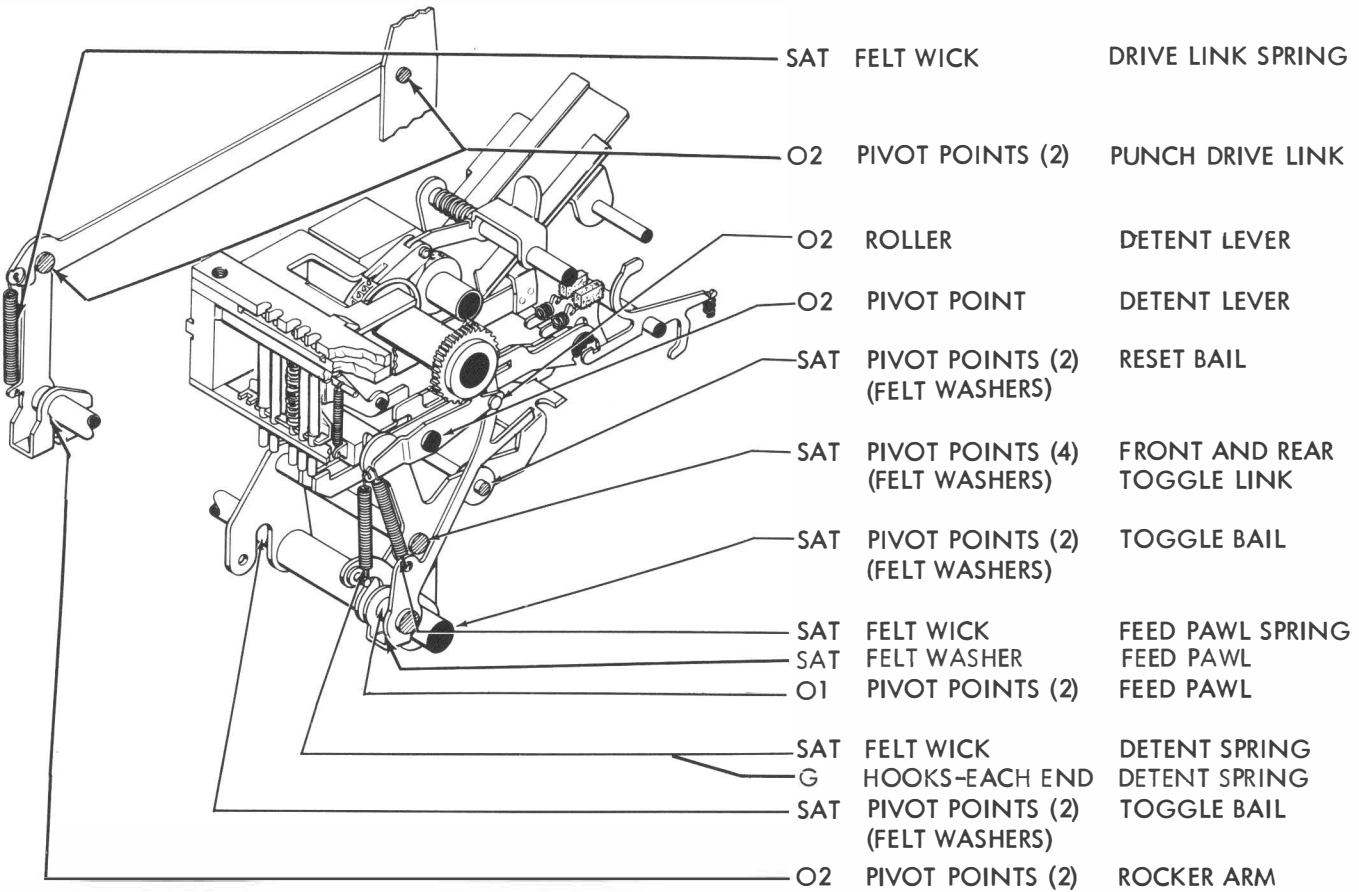

2.04 Punch Mechanism for Chadless Tape continued

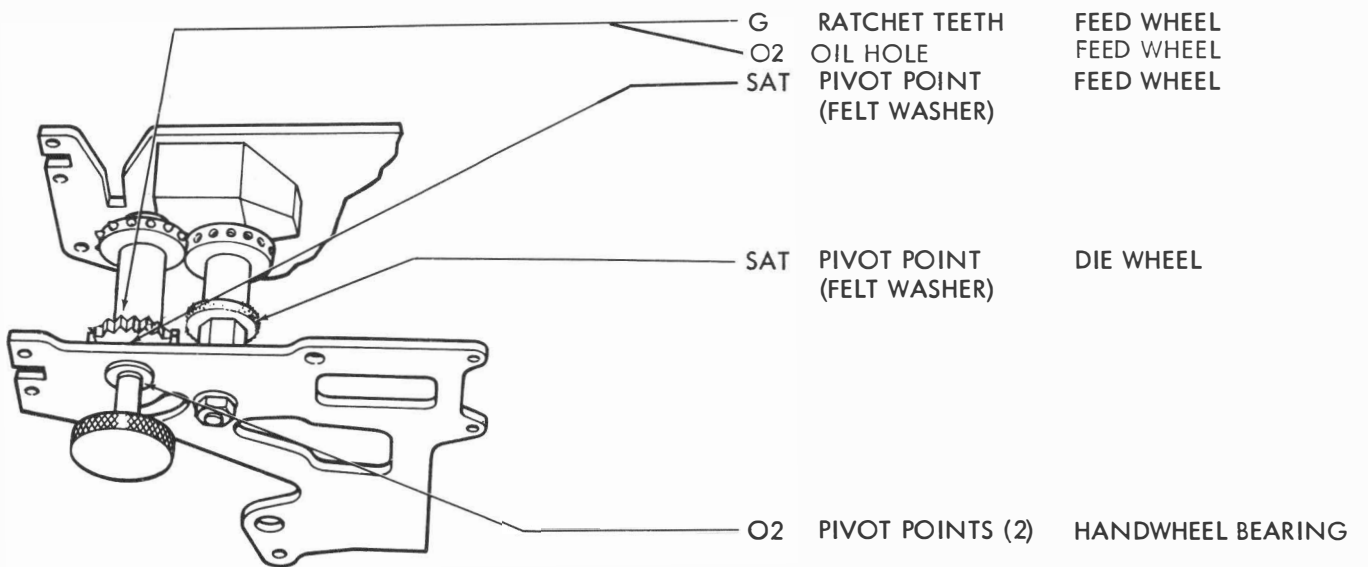
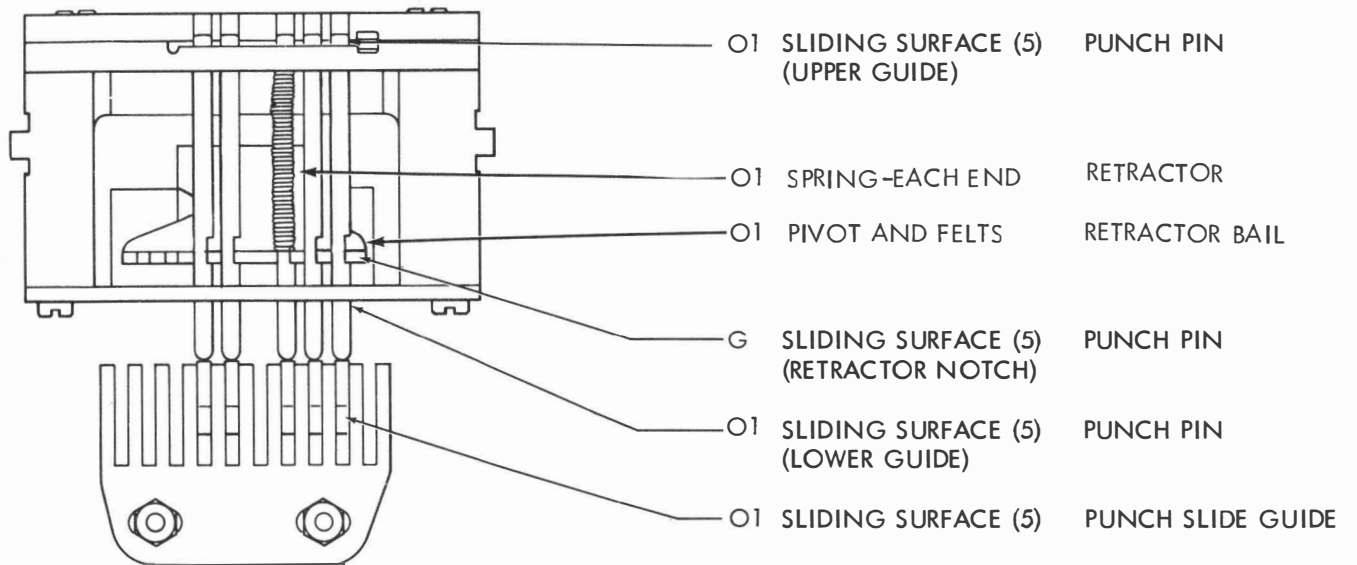

2.05 Punch Mechanism for Fully Perforated Tape

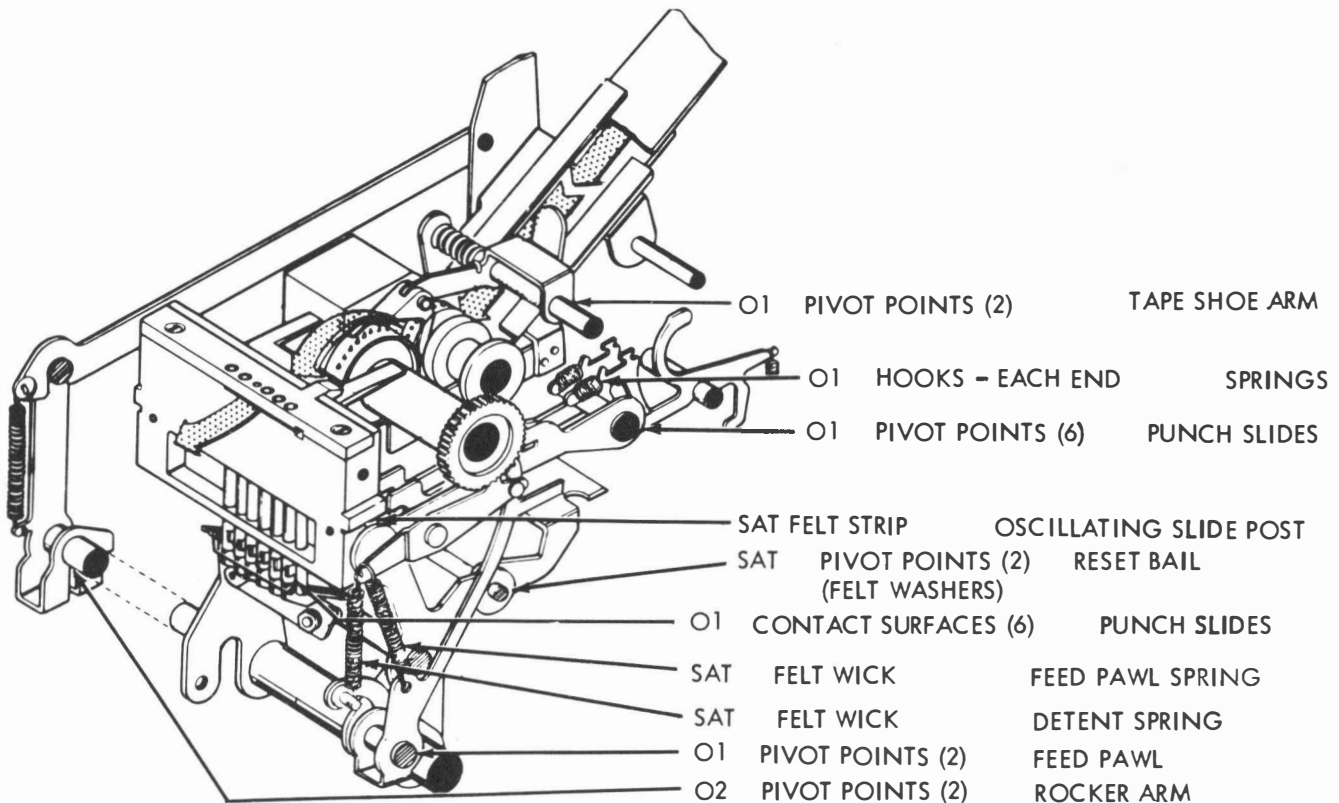
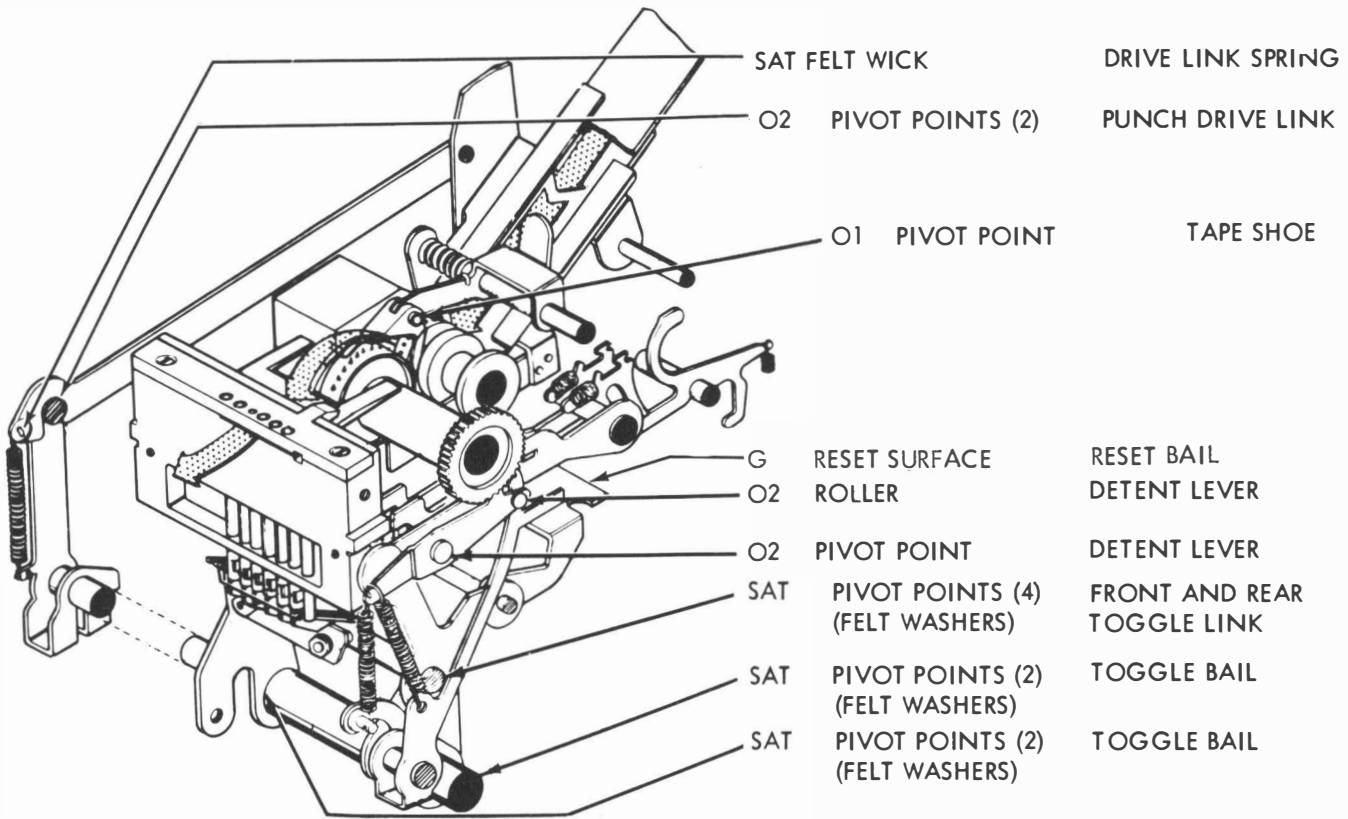

2.06 Punch Mechanism for Fully Perforated Tape continued

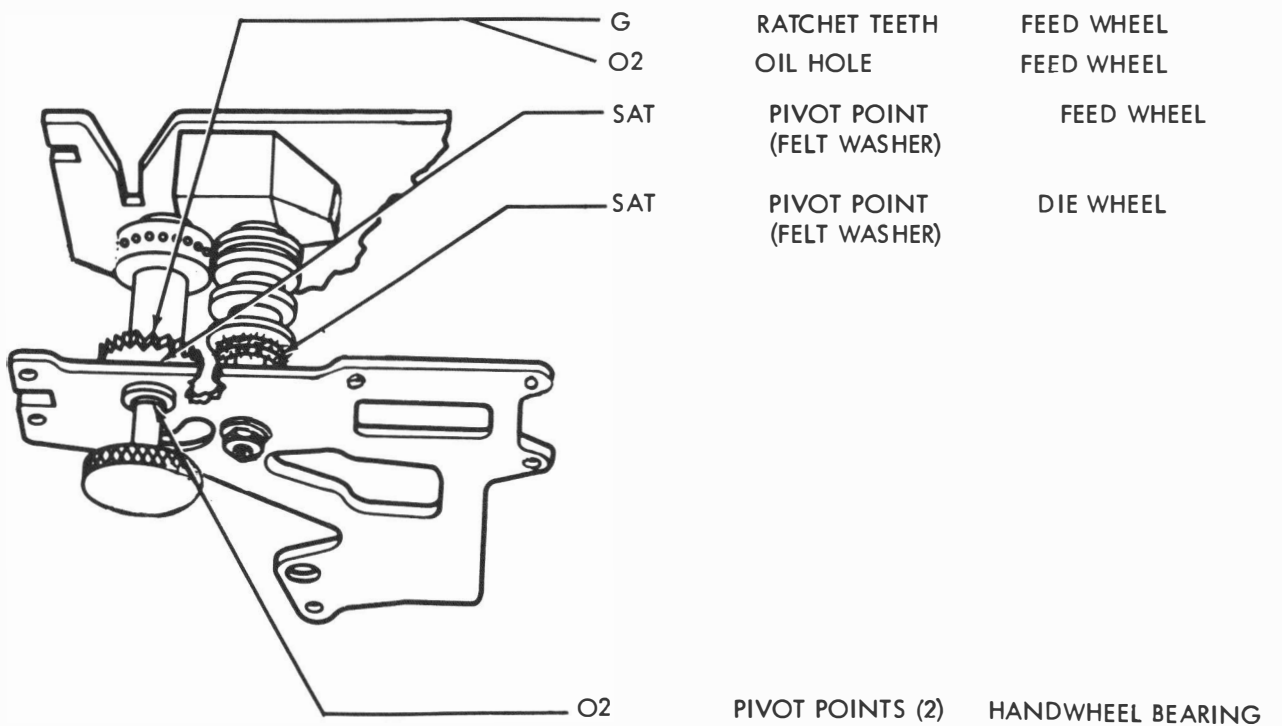
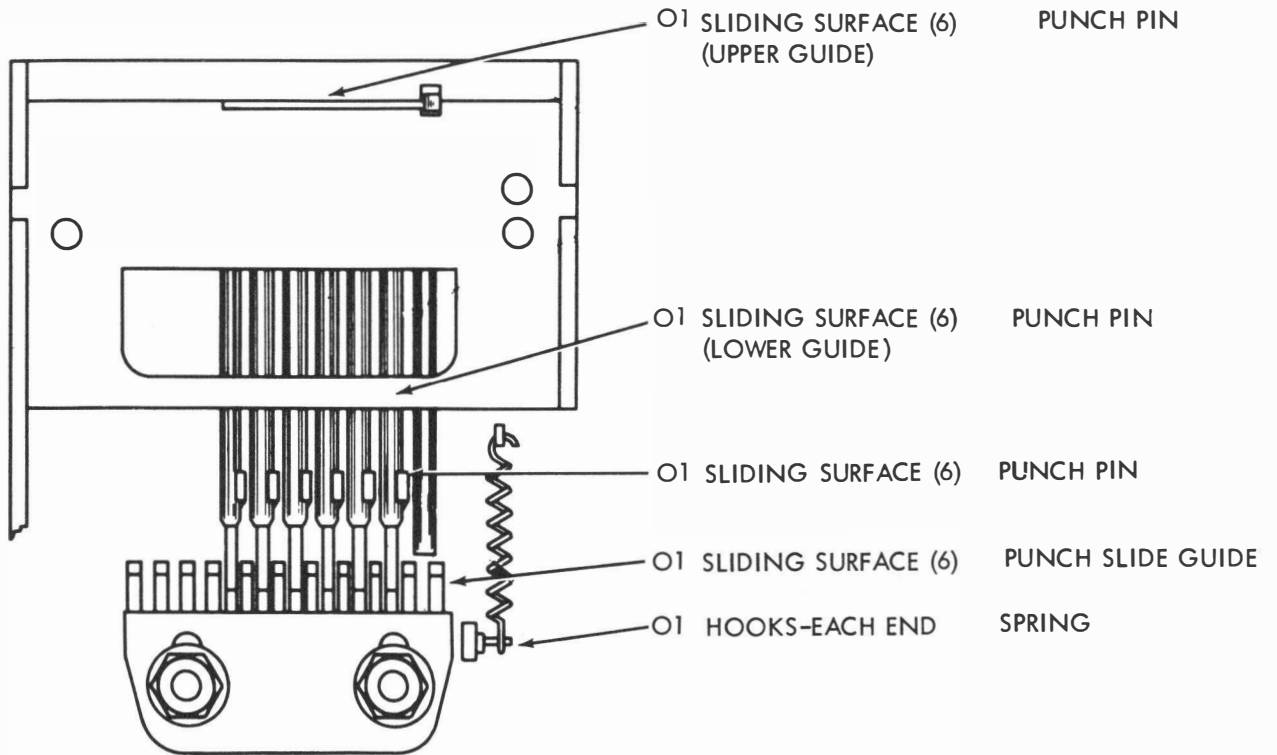

2.07 Typing Reperforator Unit

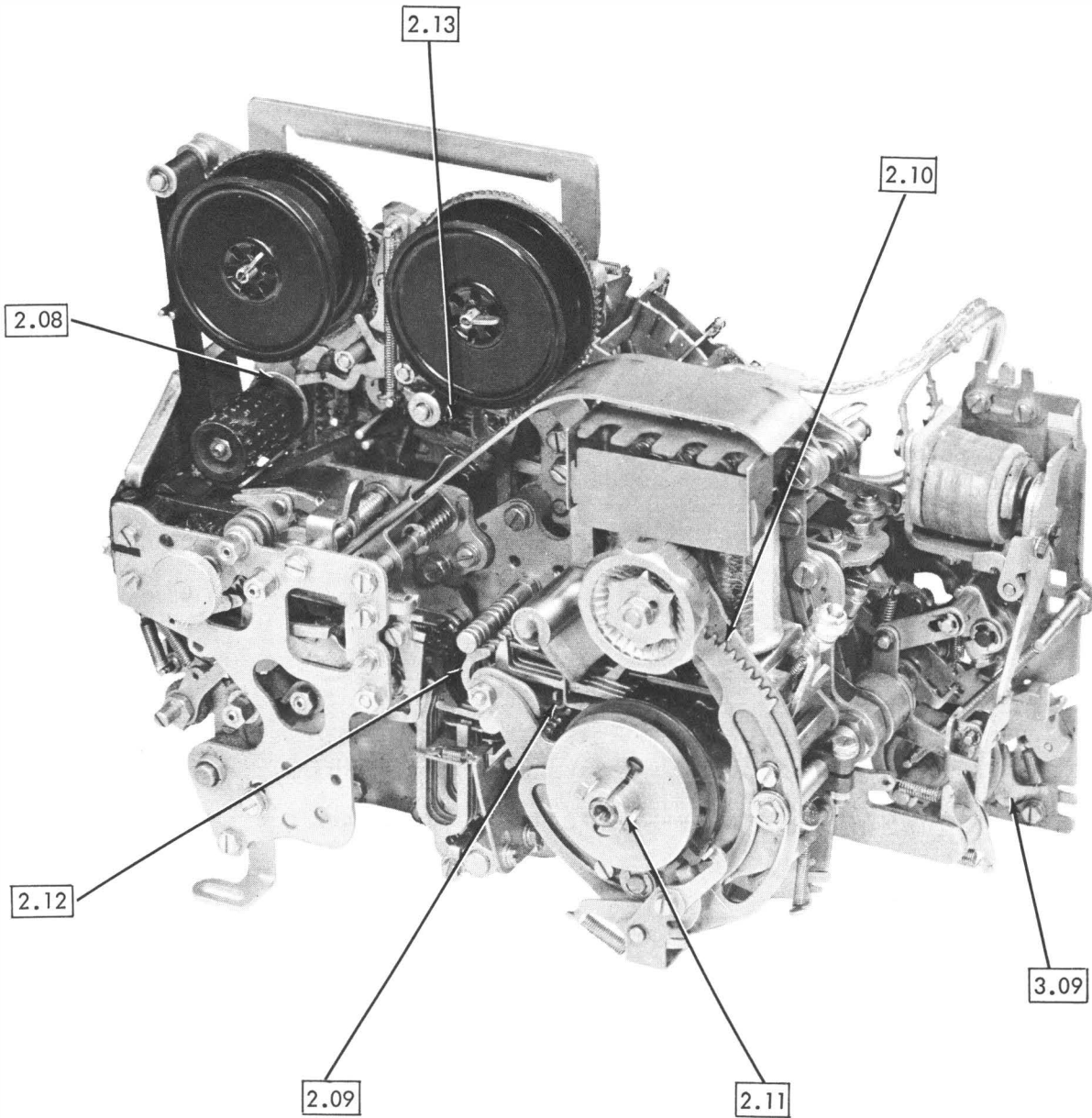

2.08 Rotary Positioning Mechanism

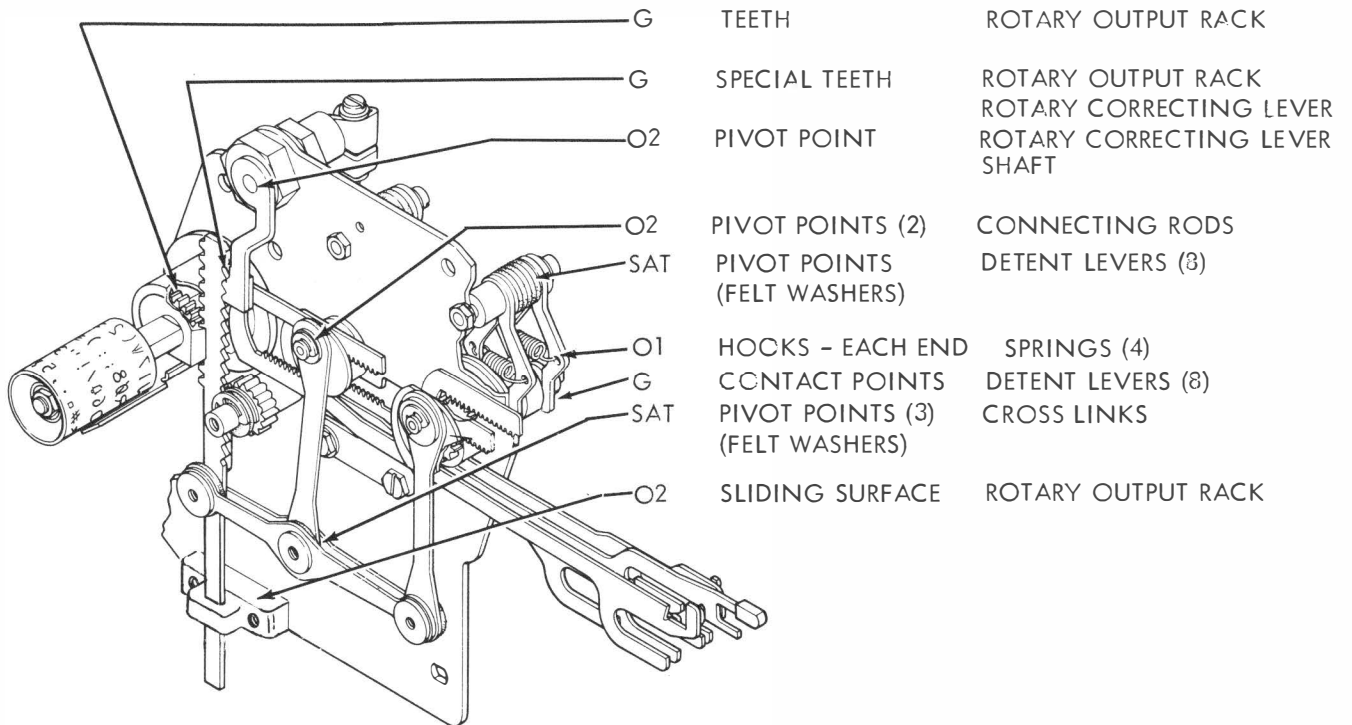

2.09 Selector Mechanism

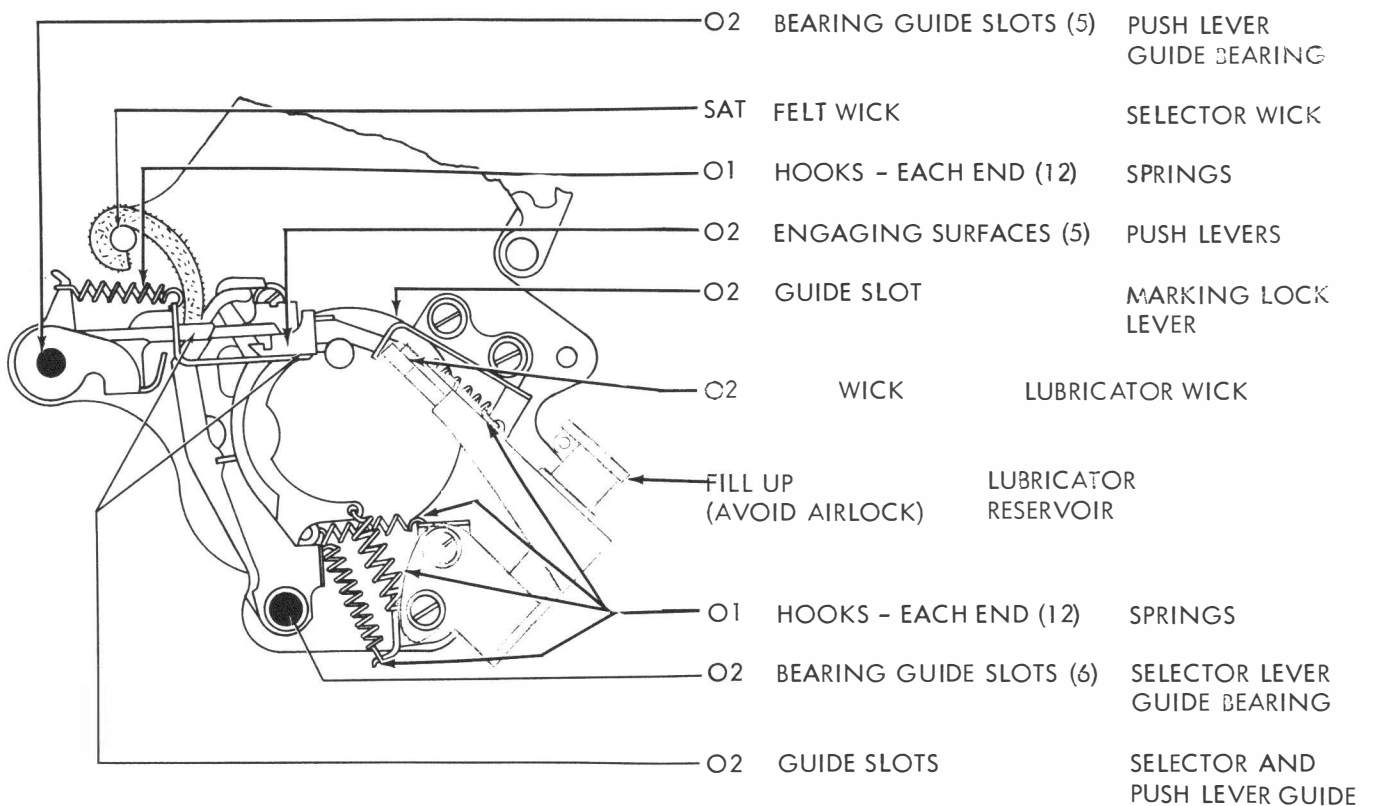

2.10 Range Finder Mechanism

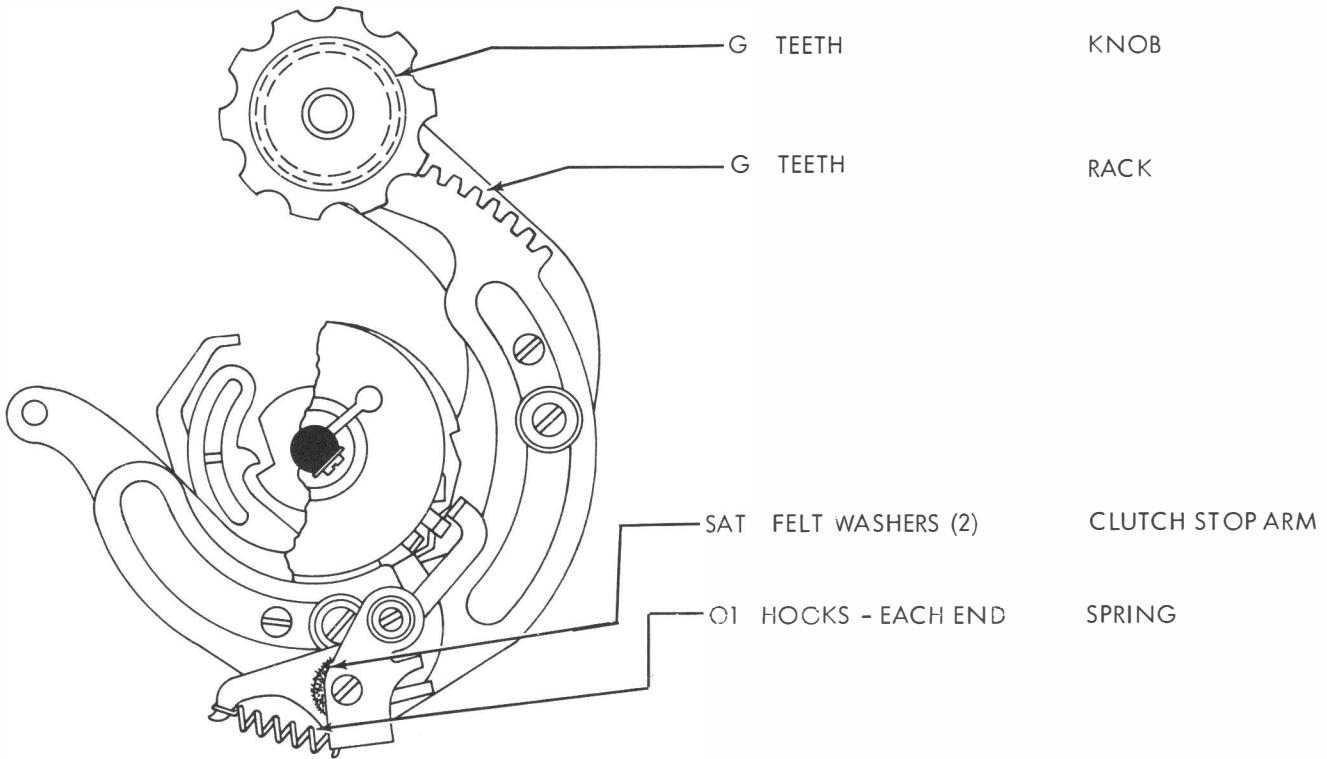

2.11 Main Shaft Mechanism

*IF FUNCTION CAM NEEDLE BEARINGS ARE DISASSEMBLED AT ANY TIME, REPACK BEARINGS WITH GREASE (BEACON 325) (TP195298) OR ITS EQUIVALENT.

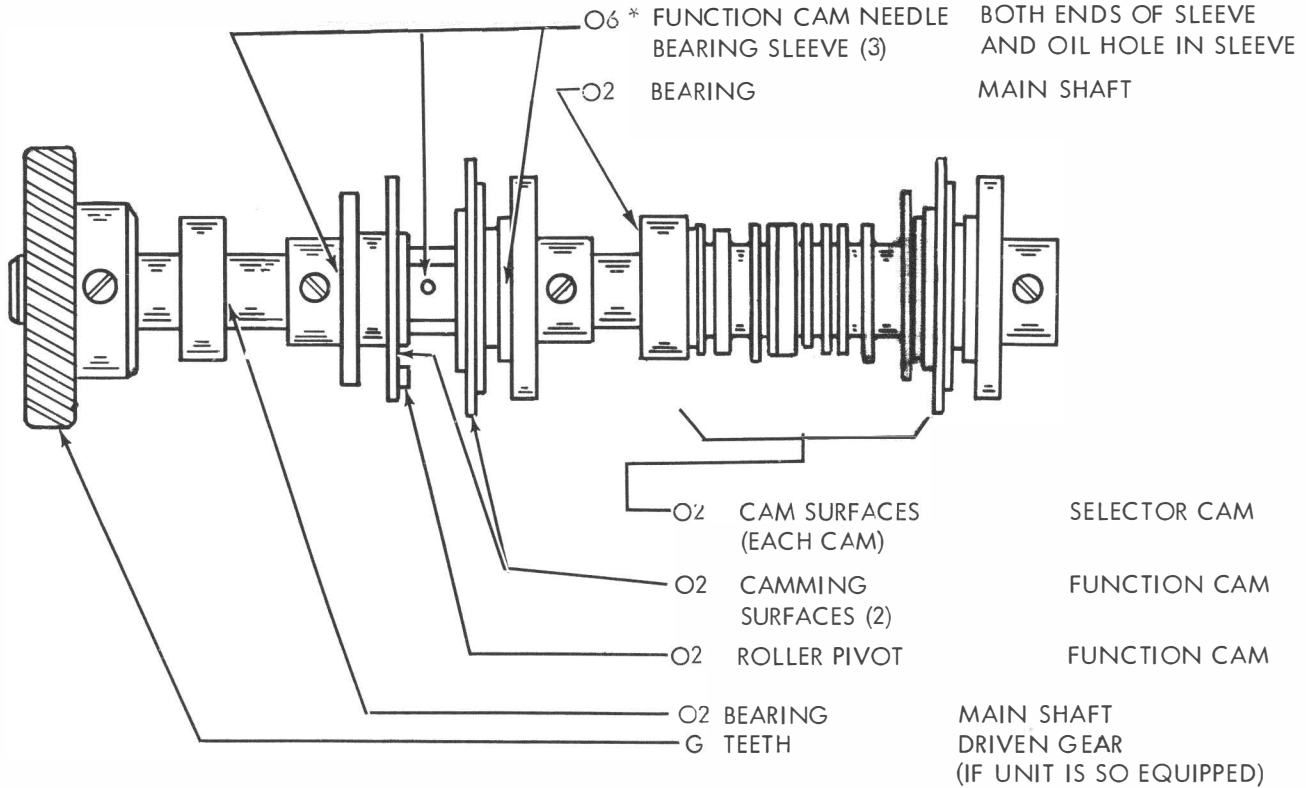

2.12 Transfer Mechanism

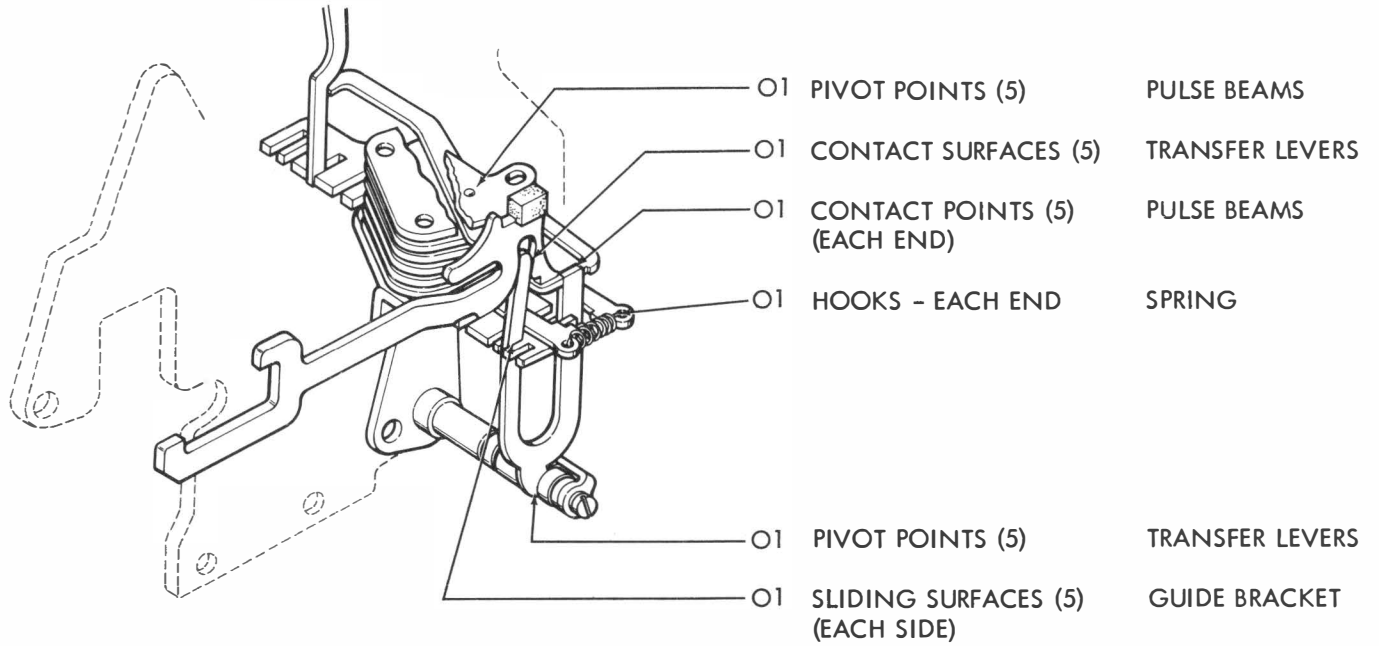

2.13 Push Bars

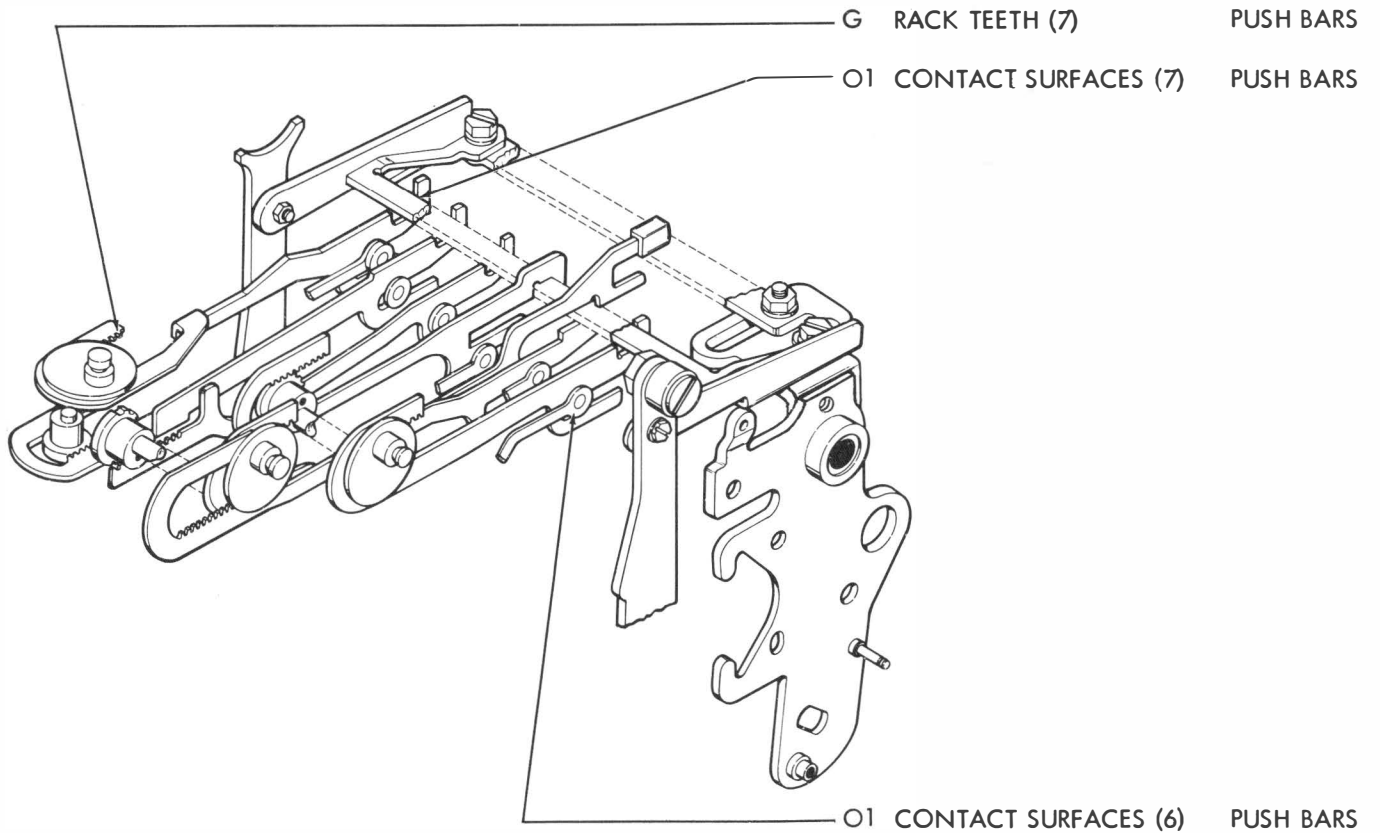

2.14 Typing Reperforator Unit

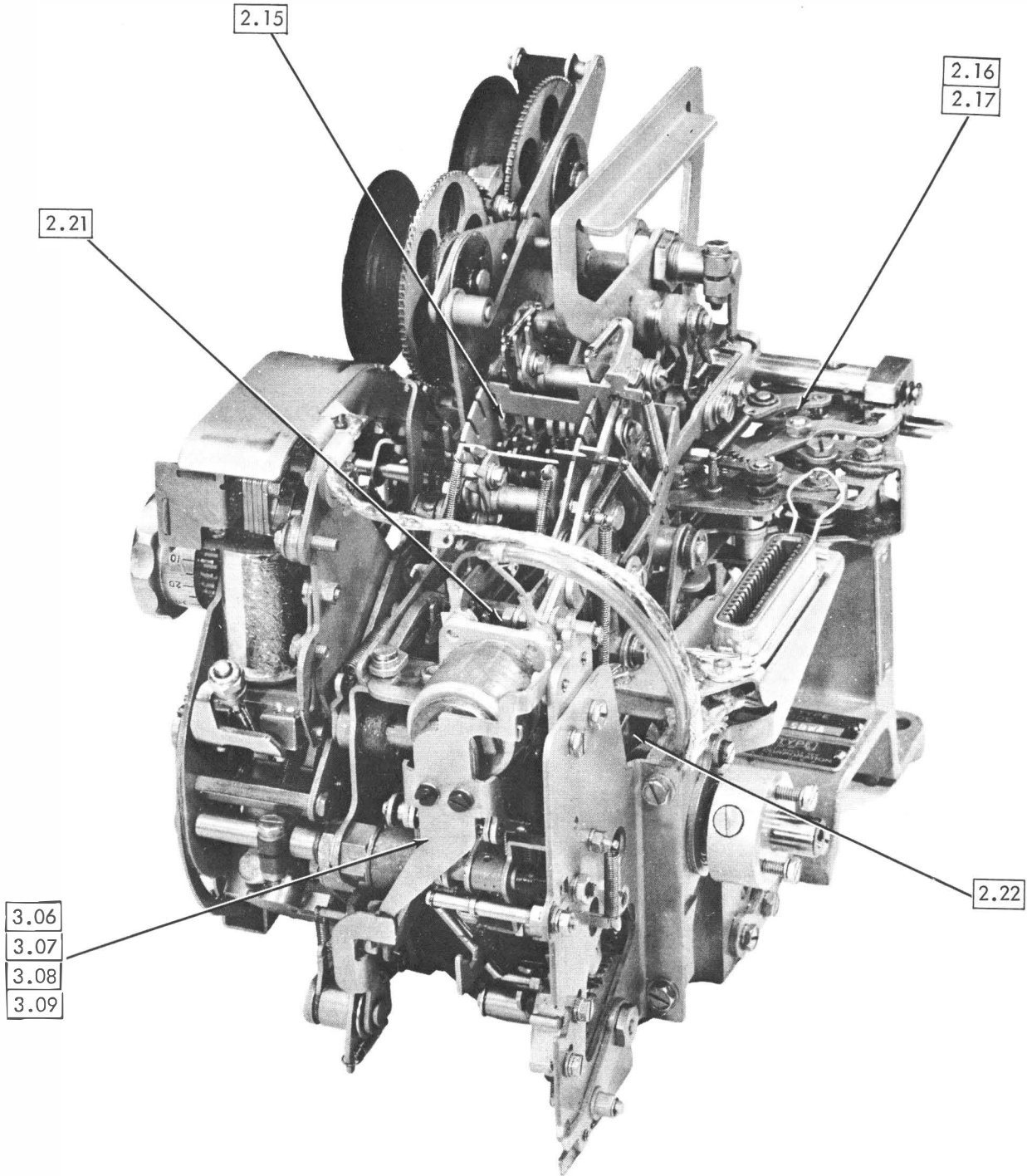

2.15 Function Box Mechanism

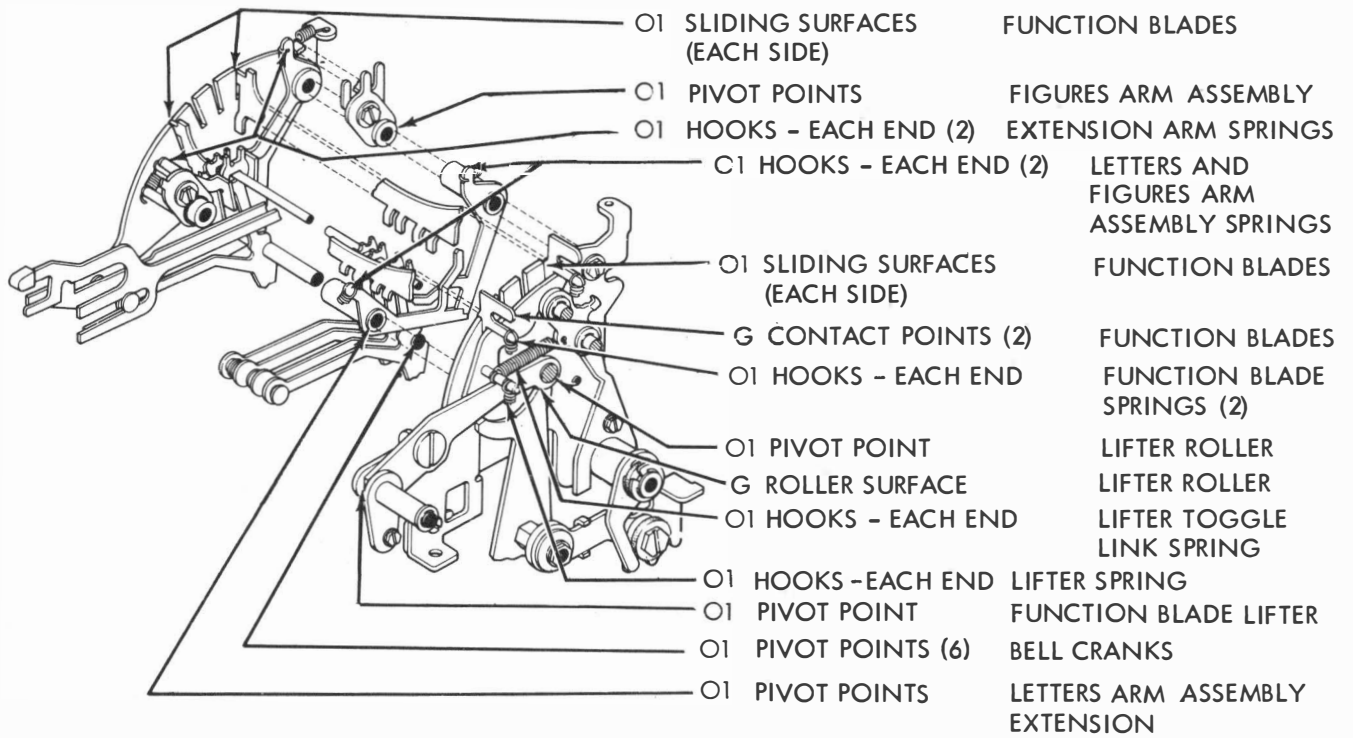

2.16 Axial Positioning Mechanism

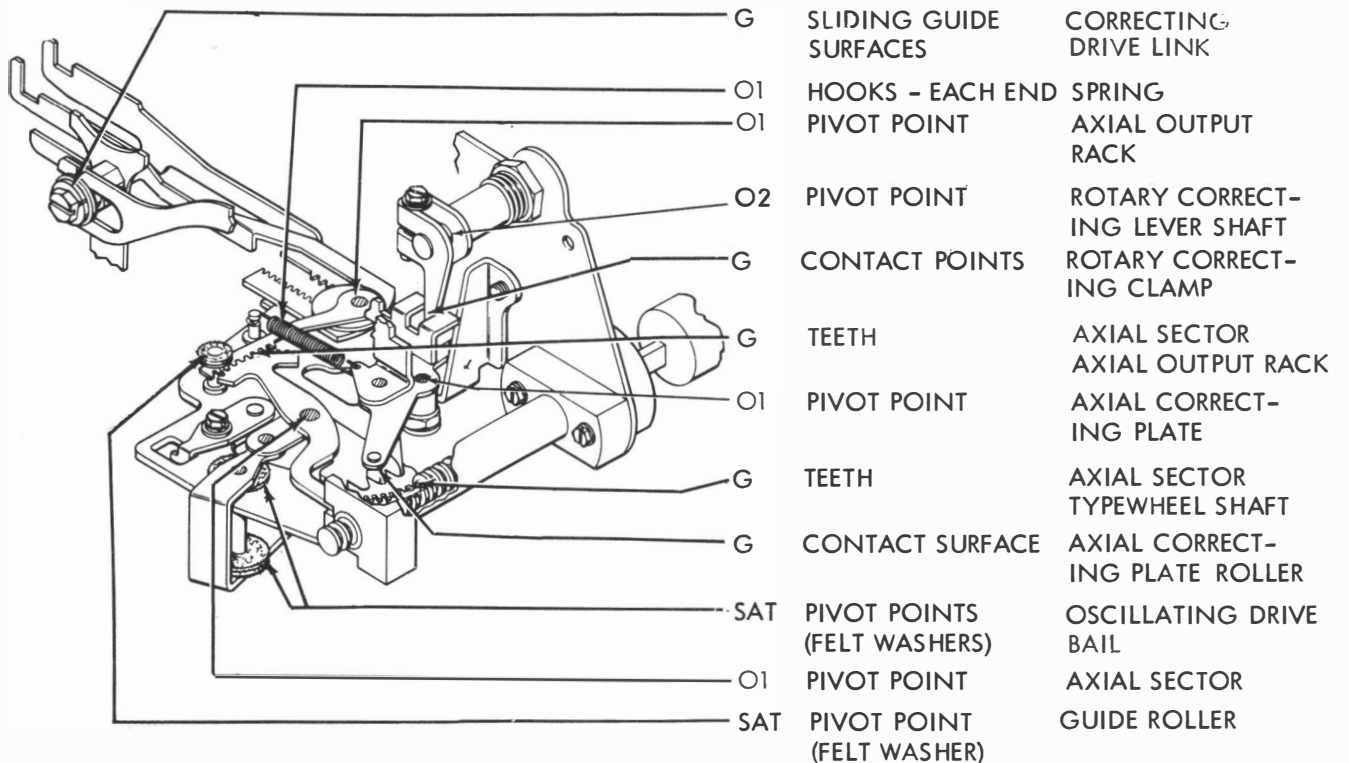

2.17 Axial Positioning Mechanism continued (Left Side View)

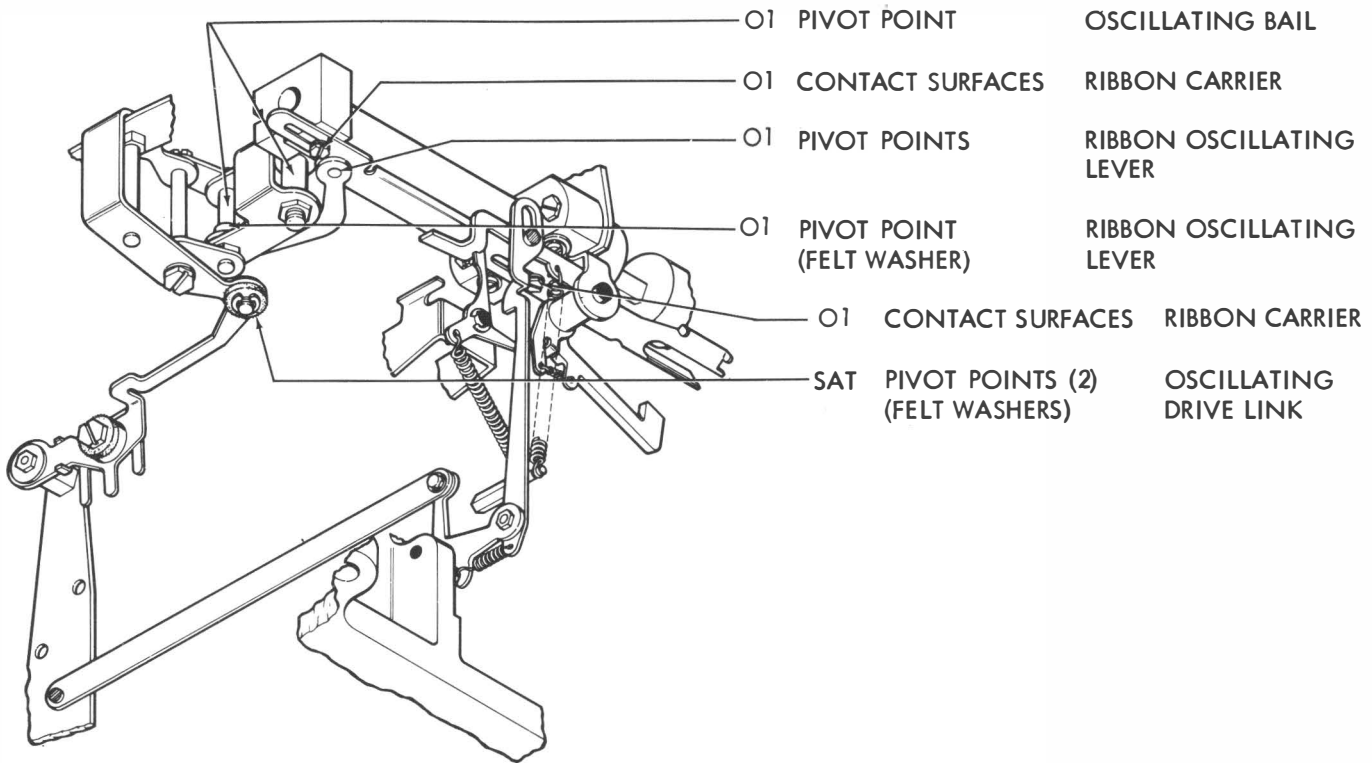

2.18 Detent Assemblies (Bottom View)

NOTE: THERE ARE TWO DETENT ASSEMBLIES ON THE AXIAL POSITIONING MECHANISM.

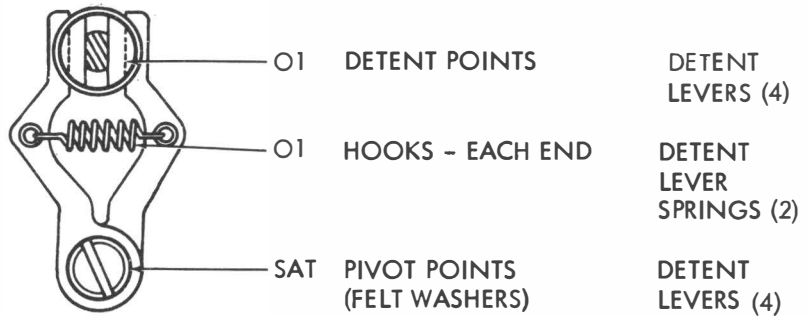

2.19 Printing Mechanism With Steel Print Hammer (Left Side View)

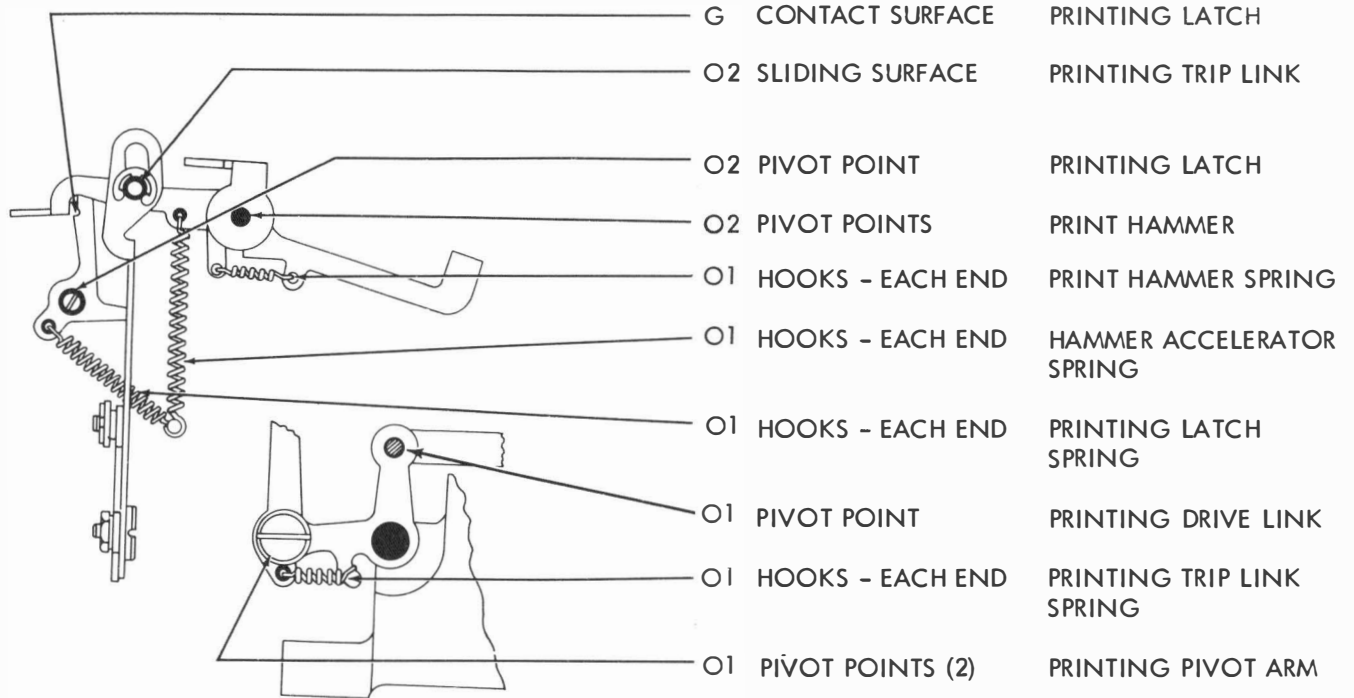

2.20 Printing Mechanism With Resilient Print Hammer (Left Side View): The printing mechanism with resilient print hammer (not illustrated) shall be lubricated in the same manner as the steel print hammer shown in 2.19 but in addition, the felt washer between the resilient

print hammer accelerator and the frame shall be saturated with oil in accordance with general lubrication procedures. Where a mechanism is equipped with print suppression parts, a thin film of grease shall be applied on print hammer stop at the point of contact with the print hammer lever.

2.21 Rocker Bail Mechanism (Rear View)

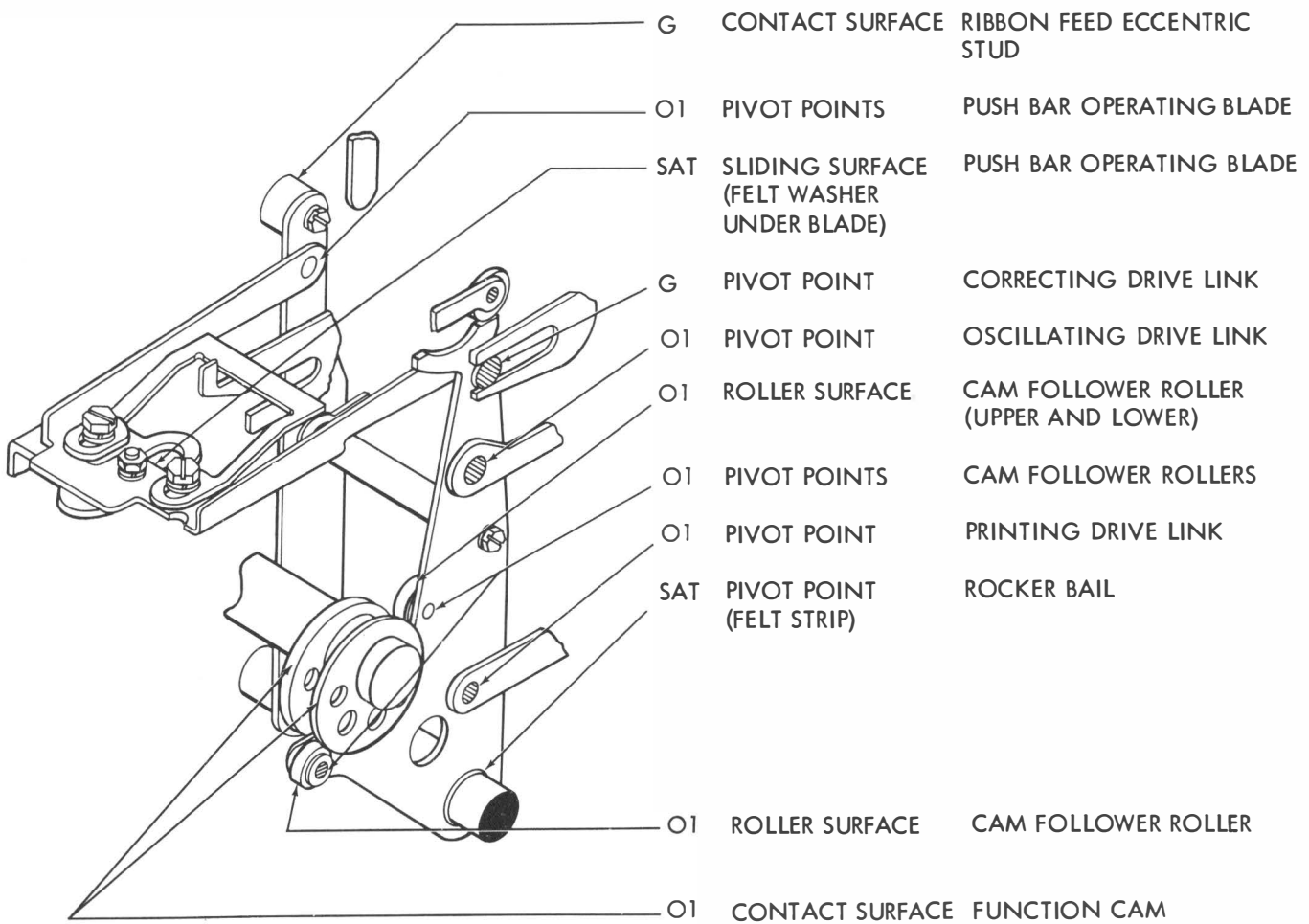

2.22 Function Cam Clutch Trip Mechanism

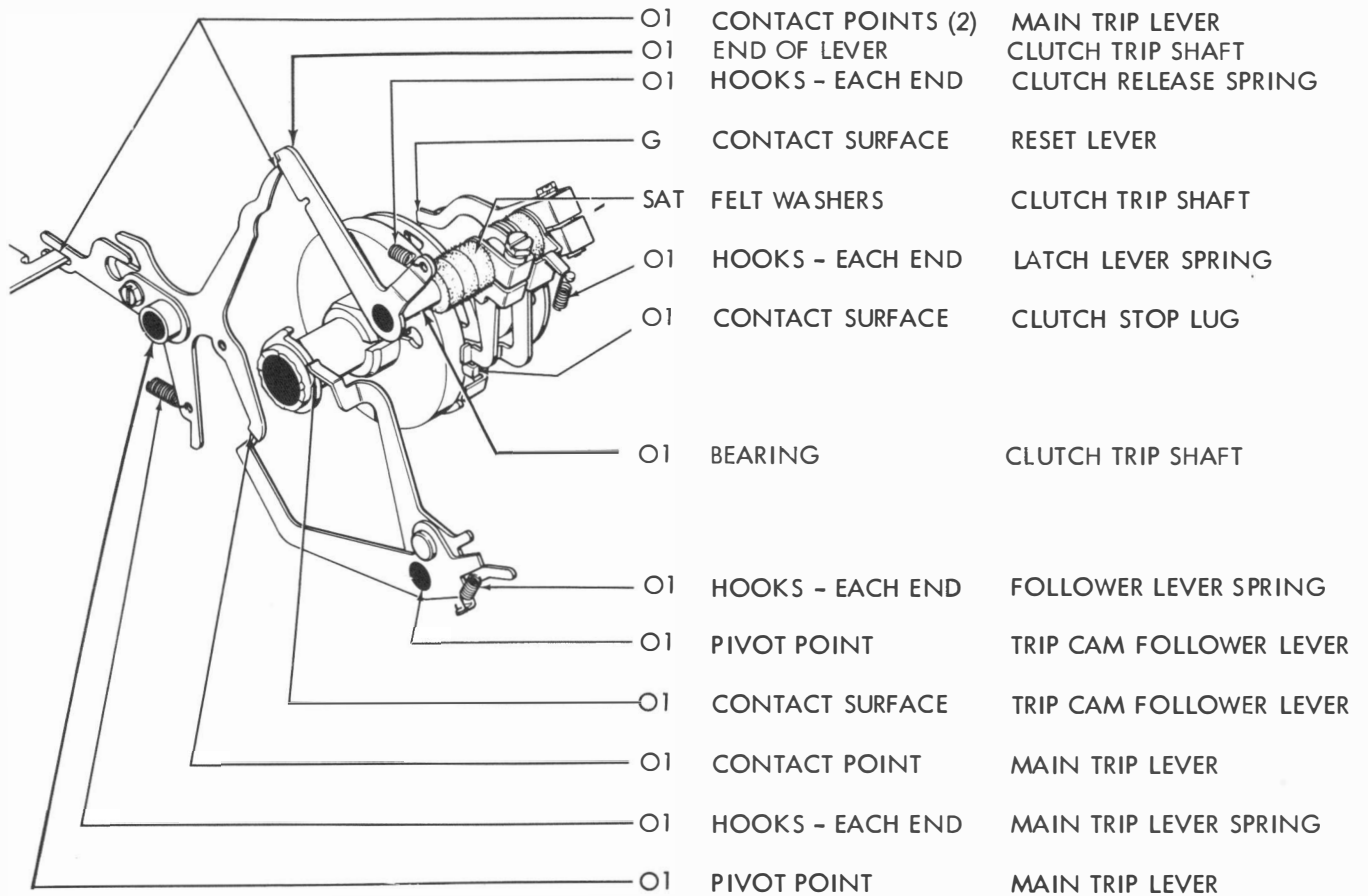

2.23 Slack Tape Mechanism

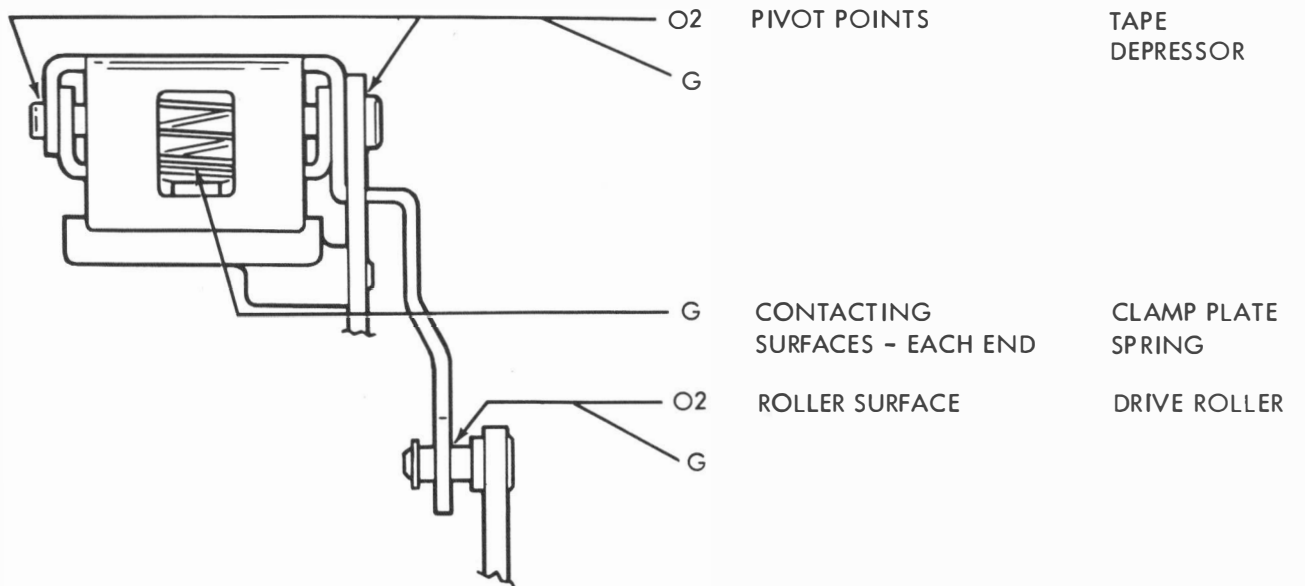

2.24 Main Shaft and Jack Shaft Mechanisms (Two Shaft Unit)

*IF FUNCTION CAM NEEDLE BEARINGS ARE DISASSEMBLED AT ANY TIME, REPACK BEARINGS WITH GREASE (BEACON 325) (TP195298) OR ITS EQUIVALENT.

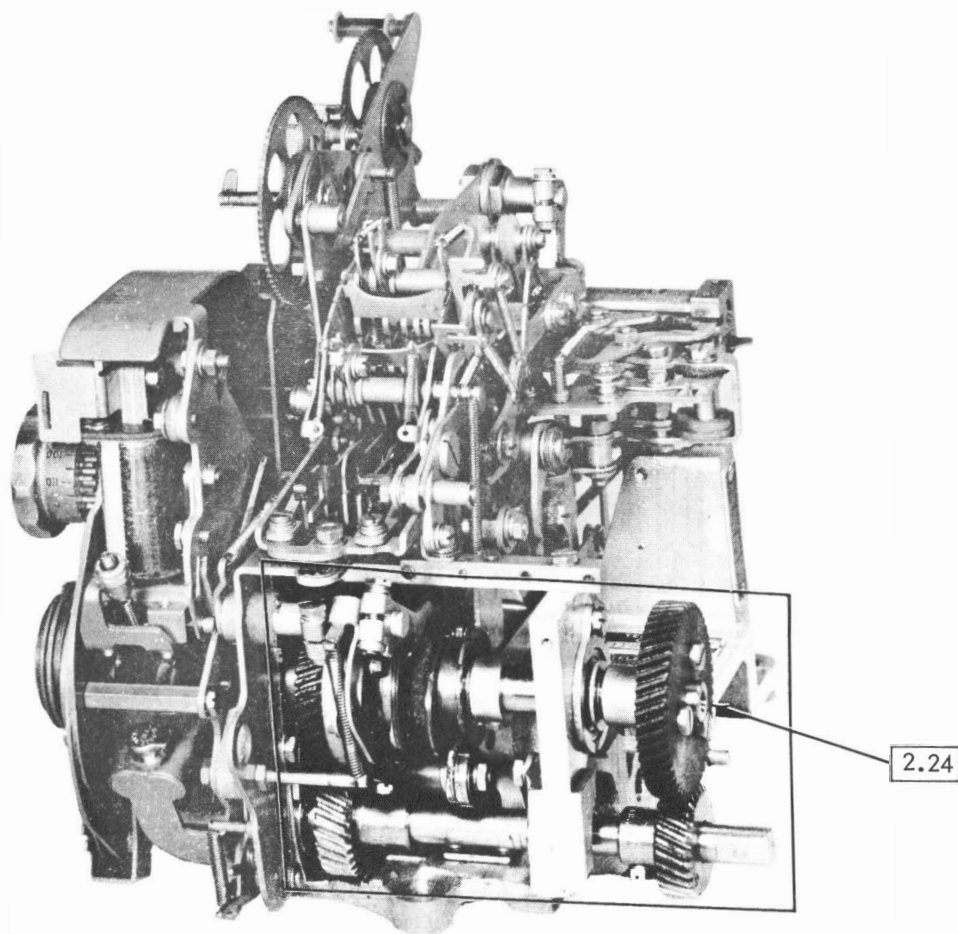
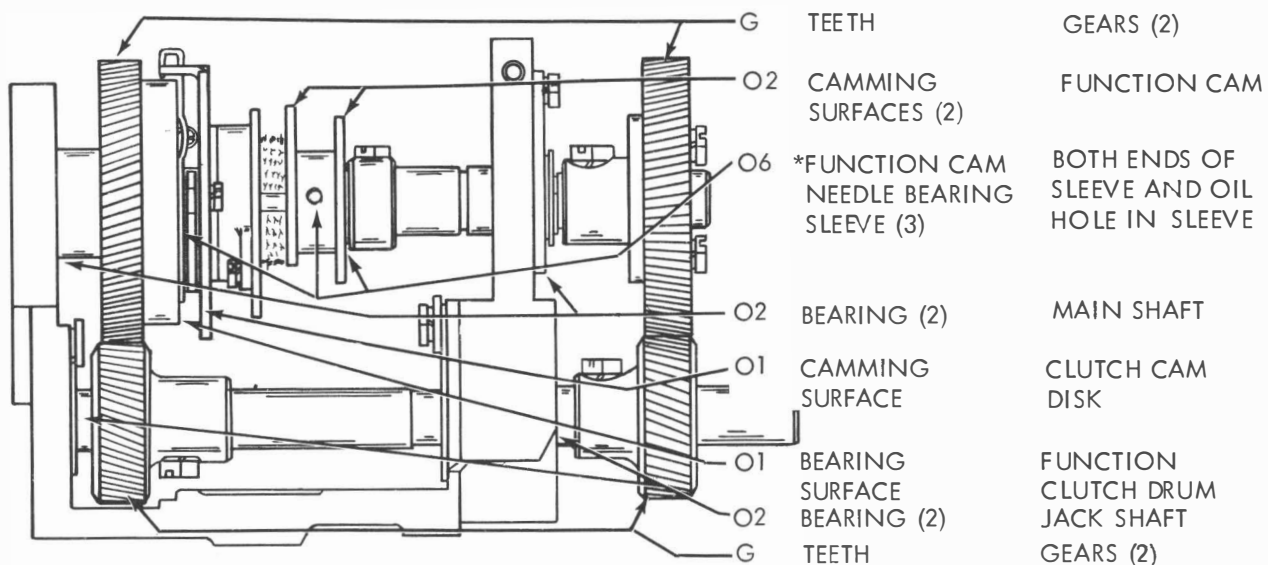

2.25 Tape Mechanism for 28 Tape Printer Unit

(THIS LUBRICATION INSTRUCTION PLUS APPLICABLE
28 TYPING REPERFORATOR LUBRICATION
INSTRUCTIONS ARE REQUIRED TO LUBRICATE THE
28 TAPE PRINTER UNIT)

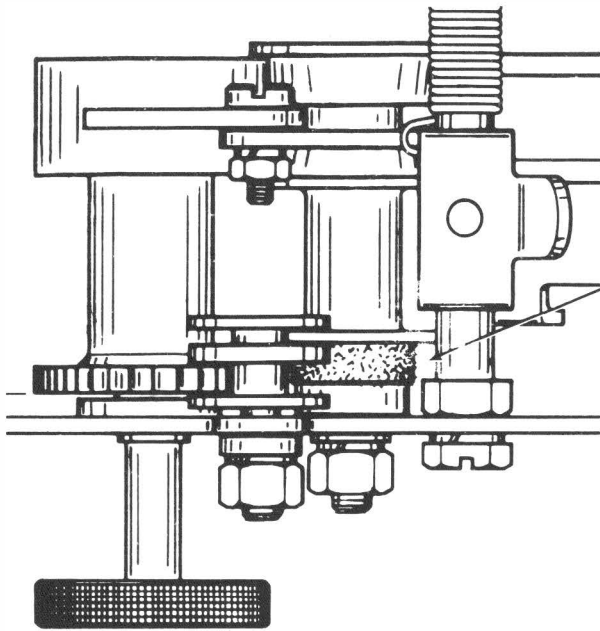

SAT FELT WASHER

TAPE MECHANISM

3. VARIABLE FEATURES

3.01 Unshift-On-Space Mechanism

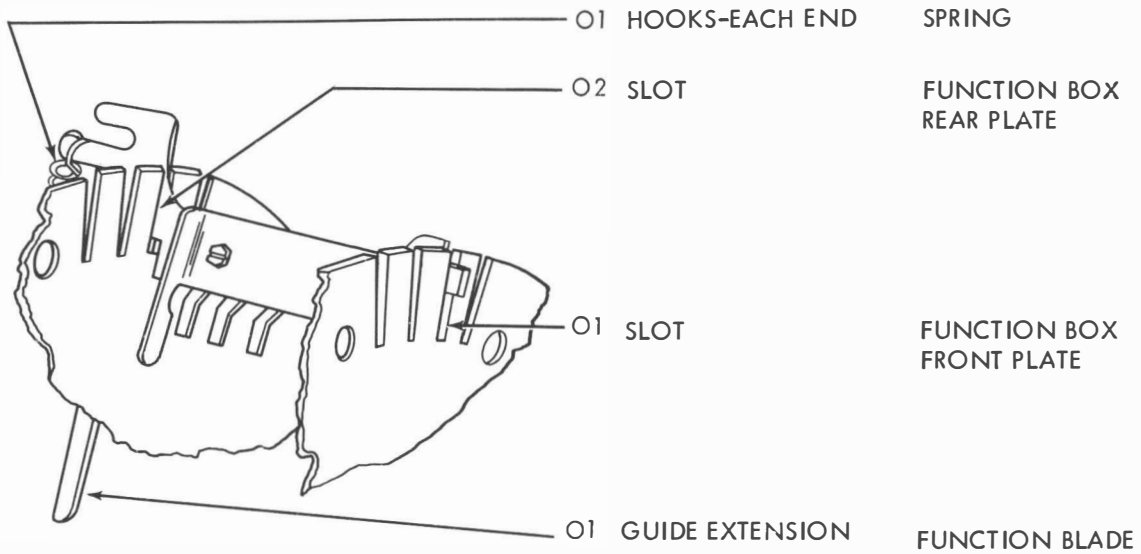

3.02 Signal Bell Contact Mechanism (Right Side View)

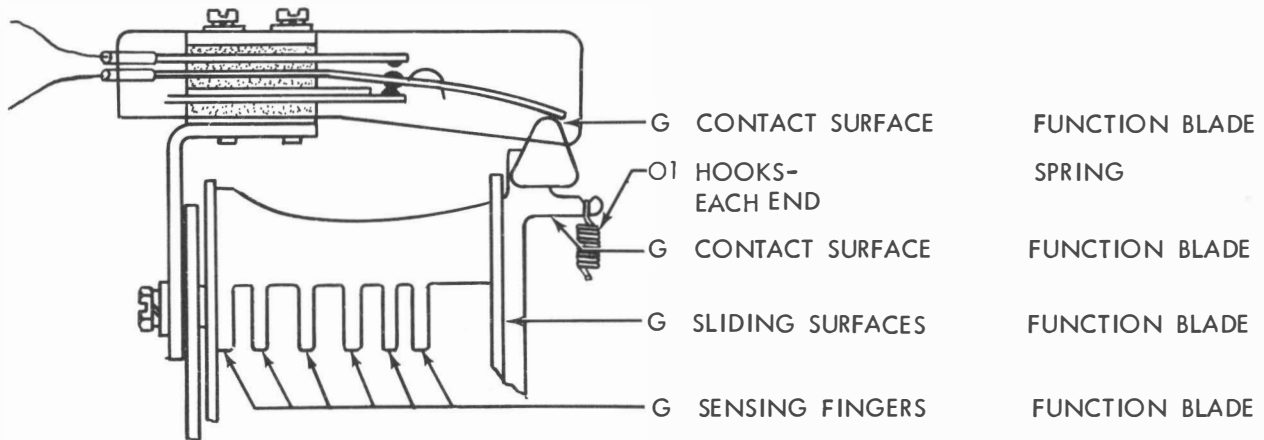

3.03 Manual and Solenoid Operated Interfering LTRS Tape Feed-Out Mechanism and Signal Bell Mechanism

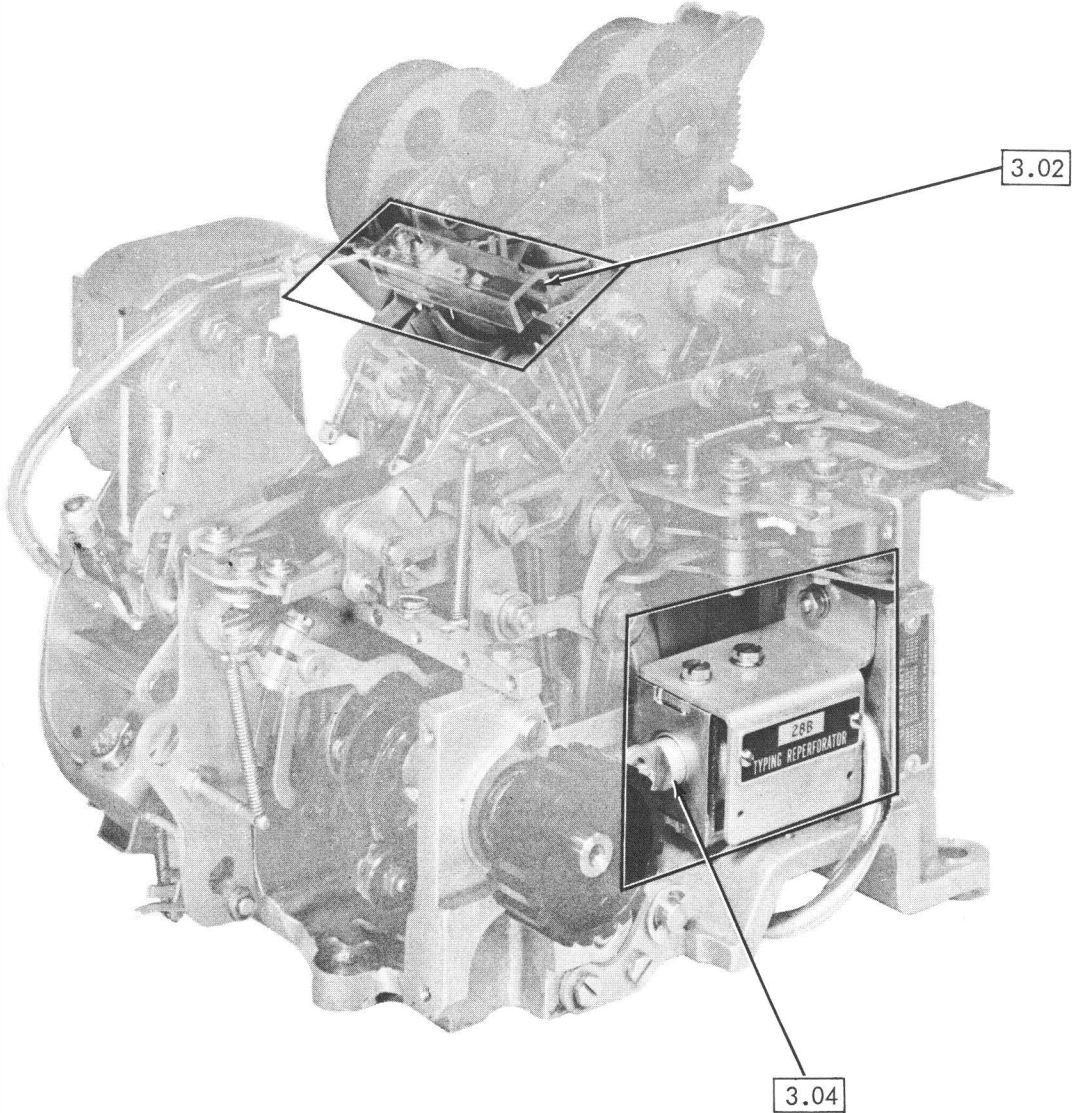

3.04 Manual and Solenoid Operated Interfering LTRS Tape Feed-Out Mechanism

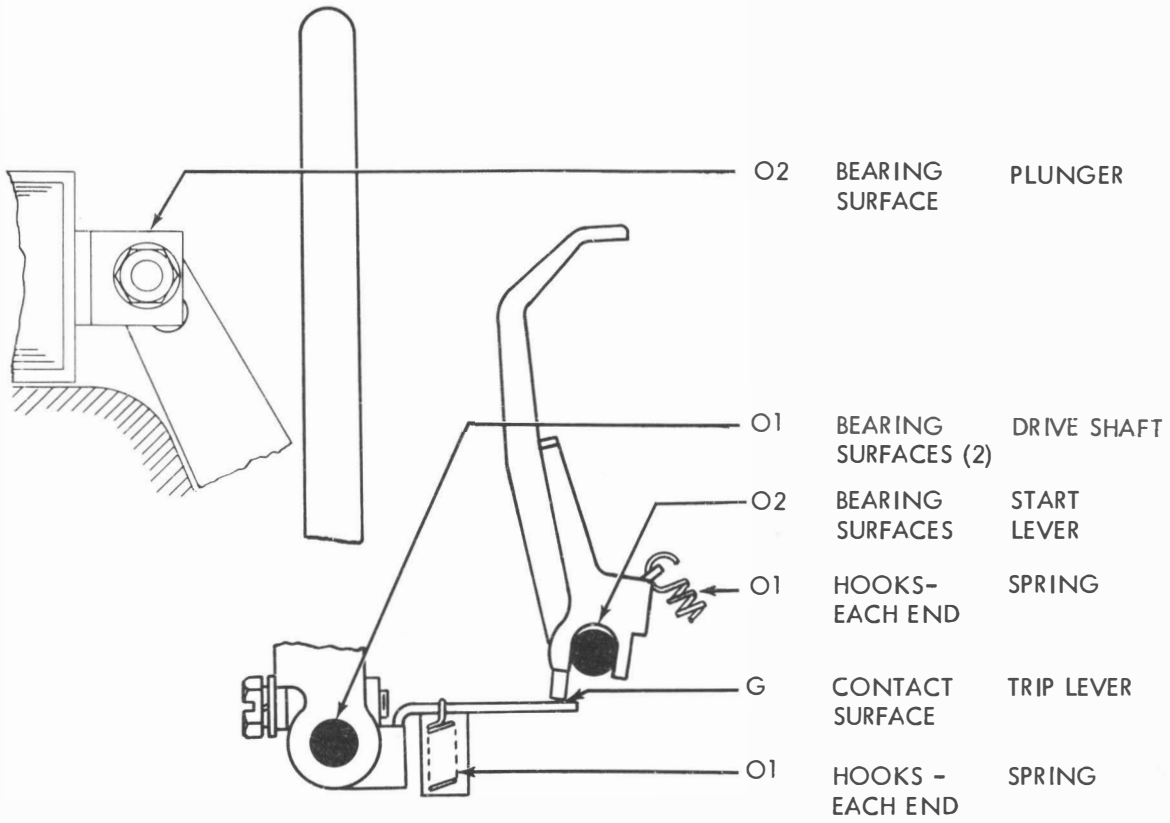

3.05 Automatic and Remote Control Noninterfering LTRS Tape Feed-Out Mechanisms

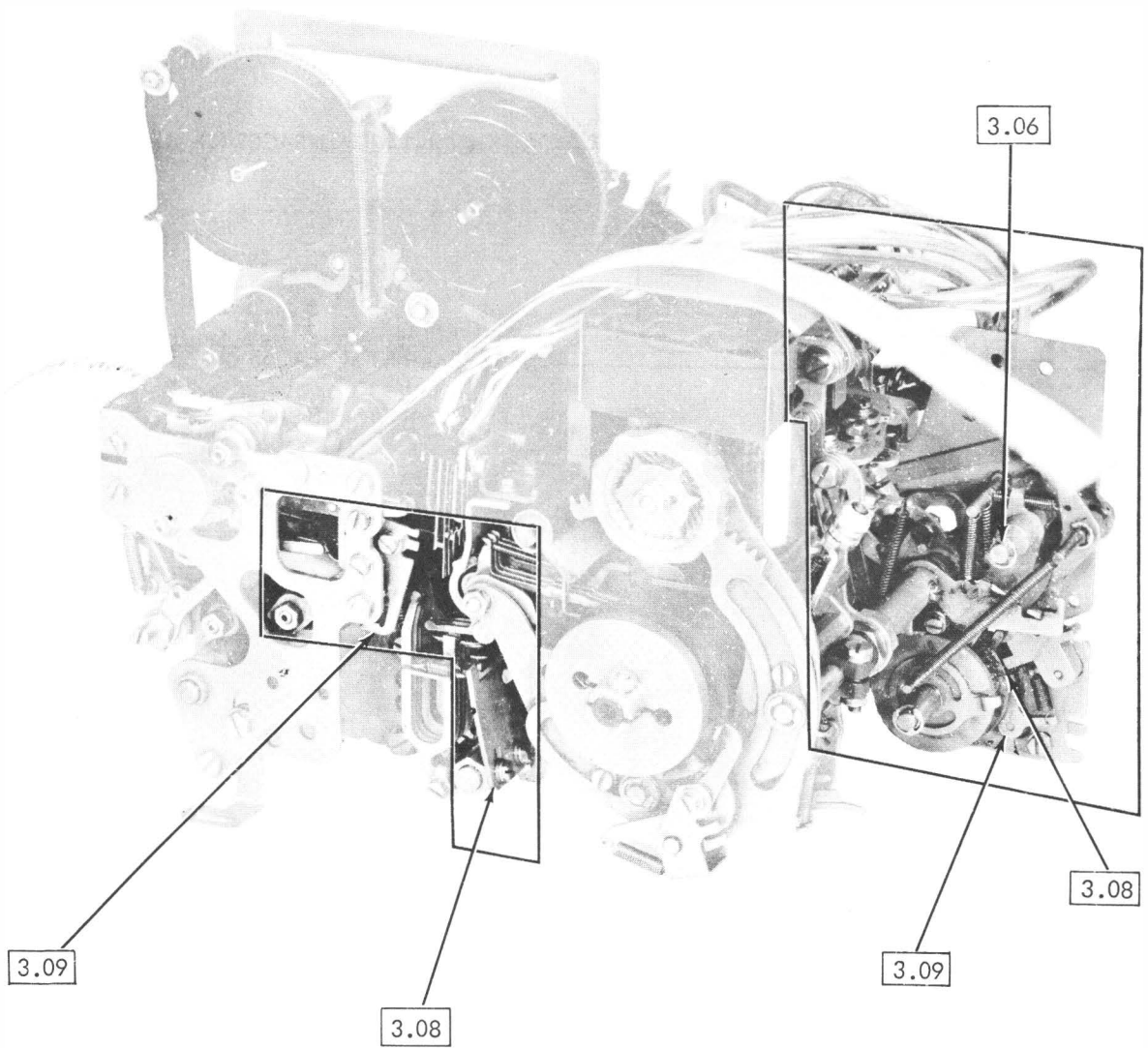

3.06 Automatic and Remote Control Noninterfering LTRS and BLANK Tape Feed-Out Mechanisms

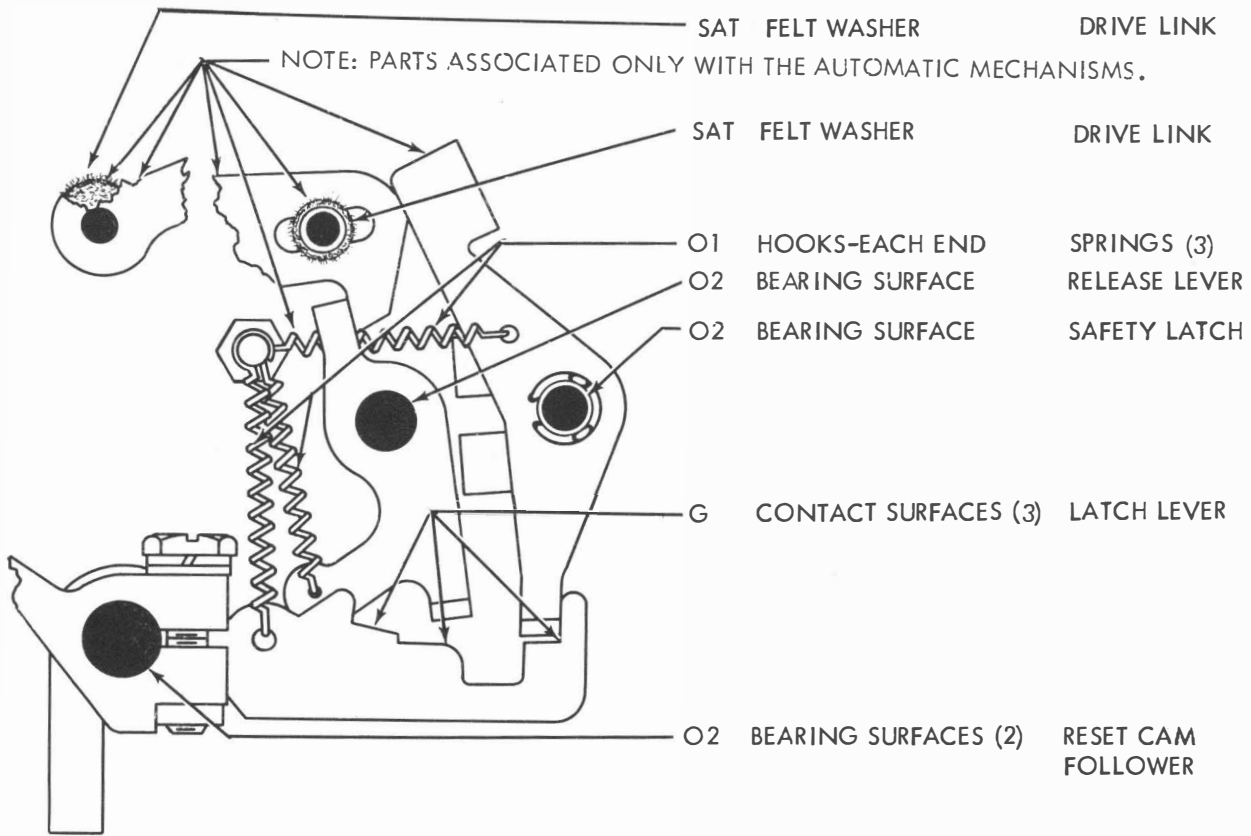

3.07 Remote Control Noninterfering LTRS and BLANK Tape Feed-Out Mechanism

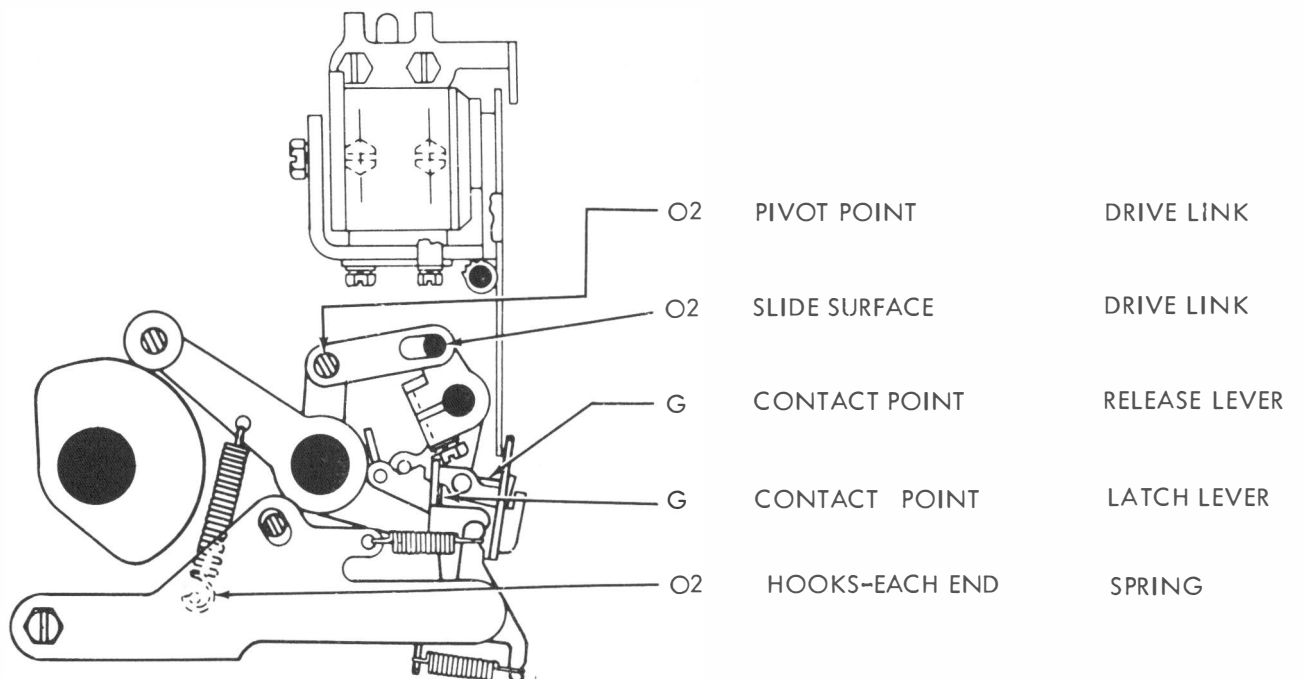
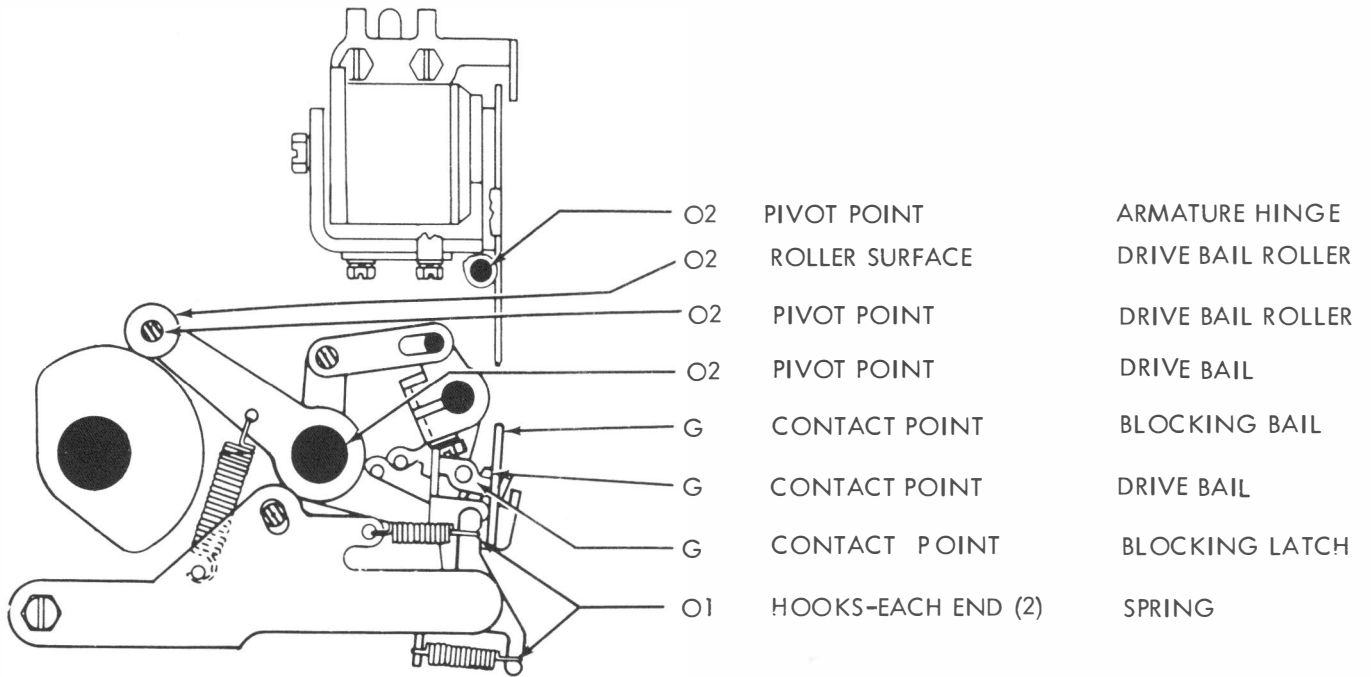

3.08 Automatic and Remote Control Noninterfering LTRS and BLANK Tape Feed-Out Mechanisms continued

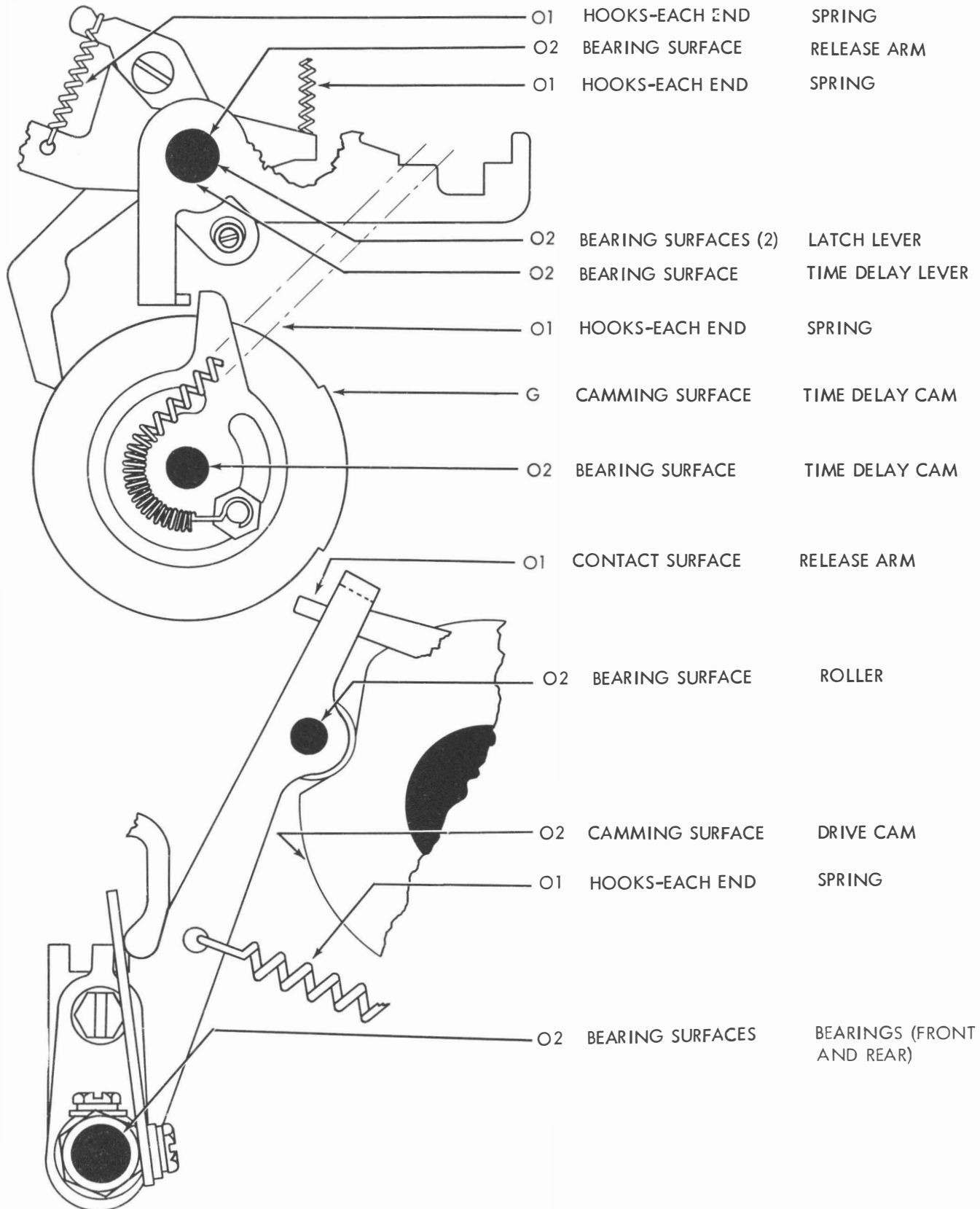

3.09 Automatic and Remote Control Noninterfering LTRS and BLANK Tape Feed-Out Mechanisms continued

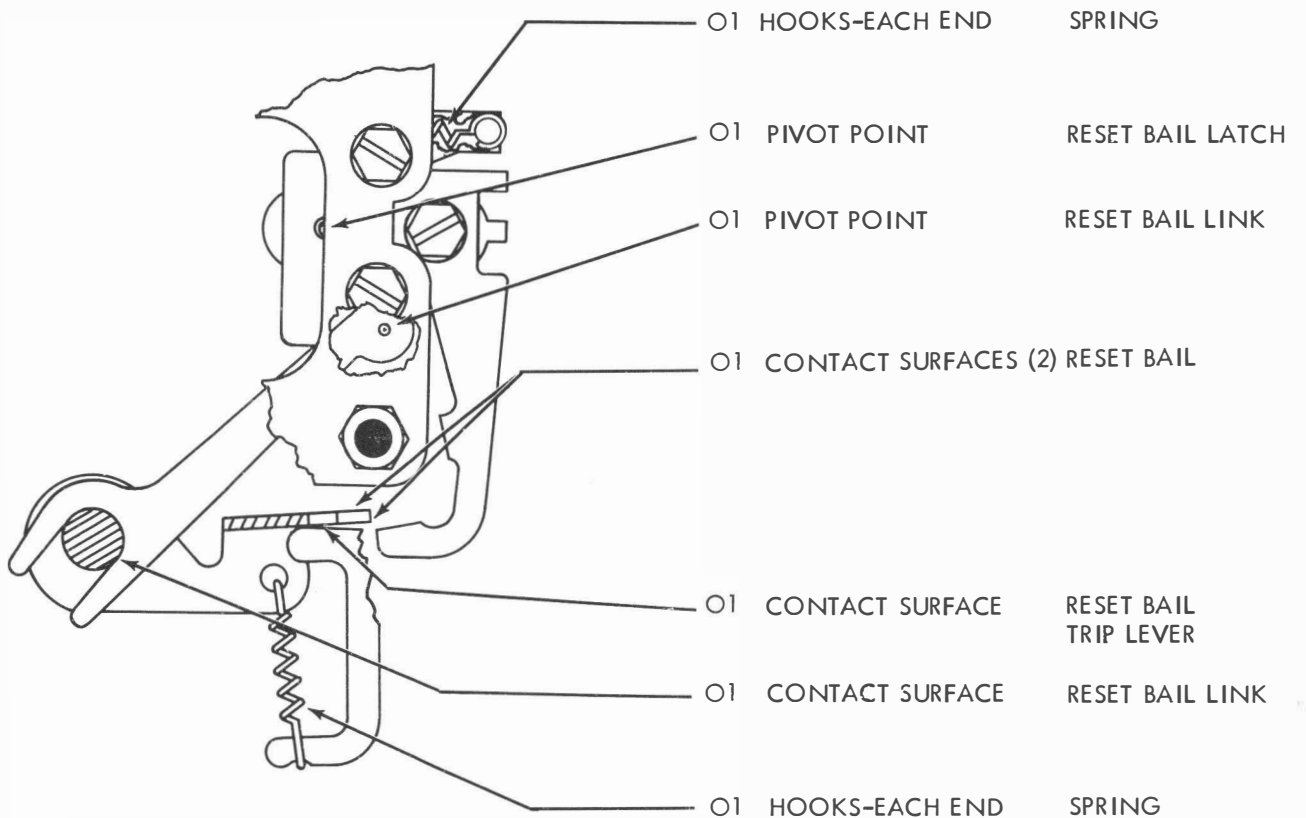
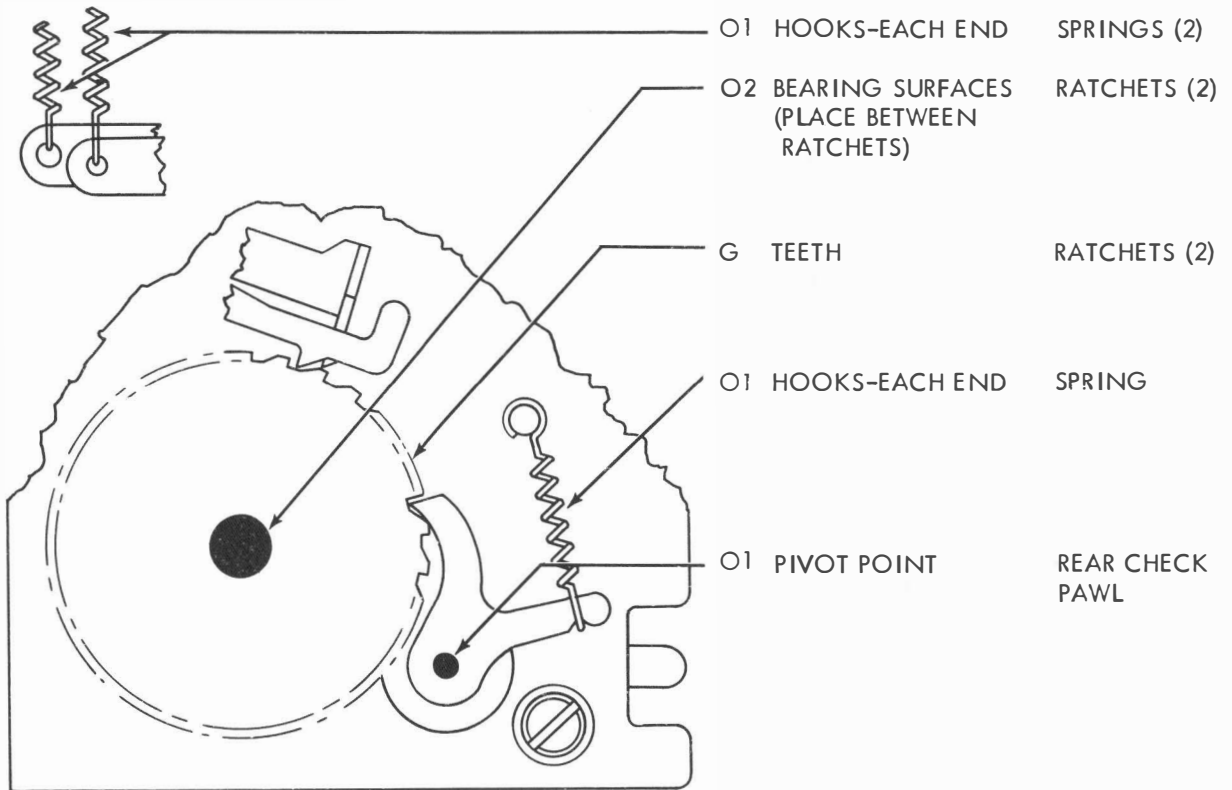

3.10 Automatic and Remote Control Noninterfering BLANK Tape Feed-Out Mechanisms

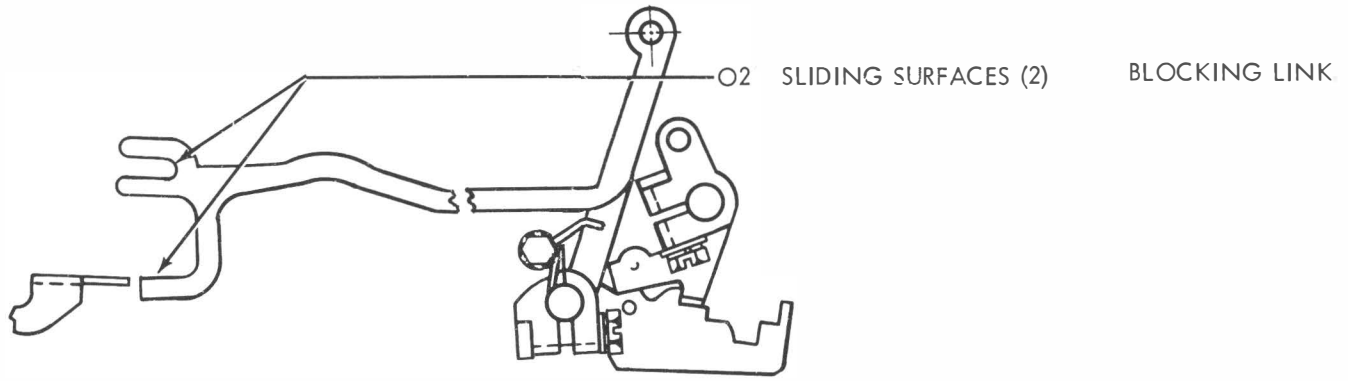
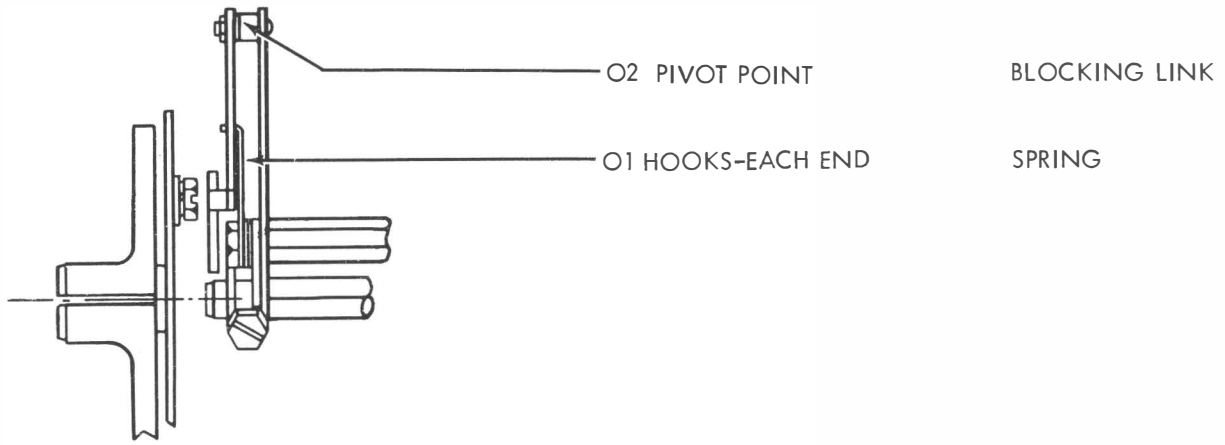

3.11 End of Tape Feed-Out Timing Contacts for Noninterfering LTRS and BLANK
Tape Feed-Out Mechanisms

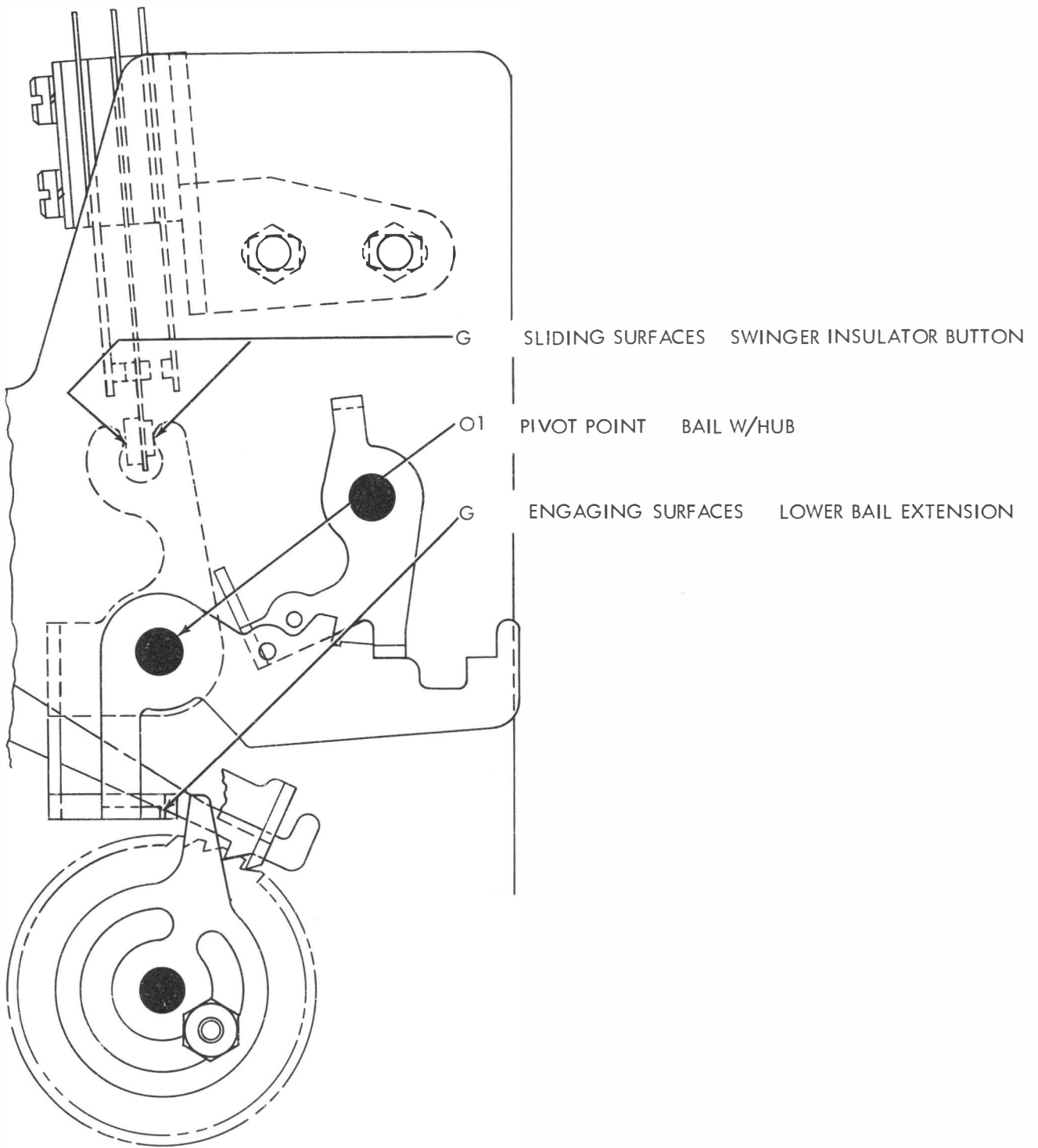

3.12 Timing Contact Mechanism (Operated by Selector)

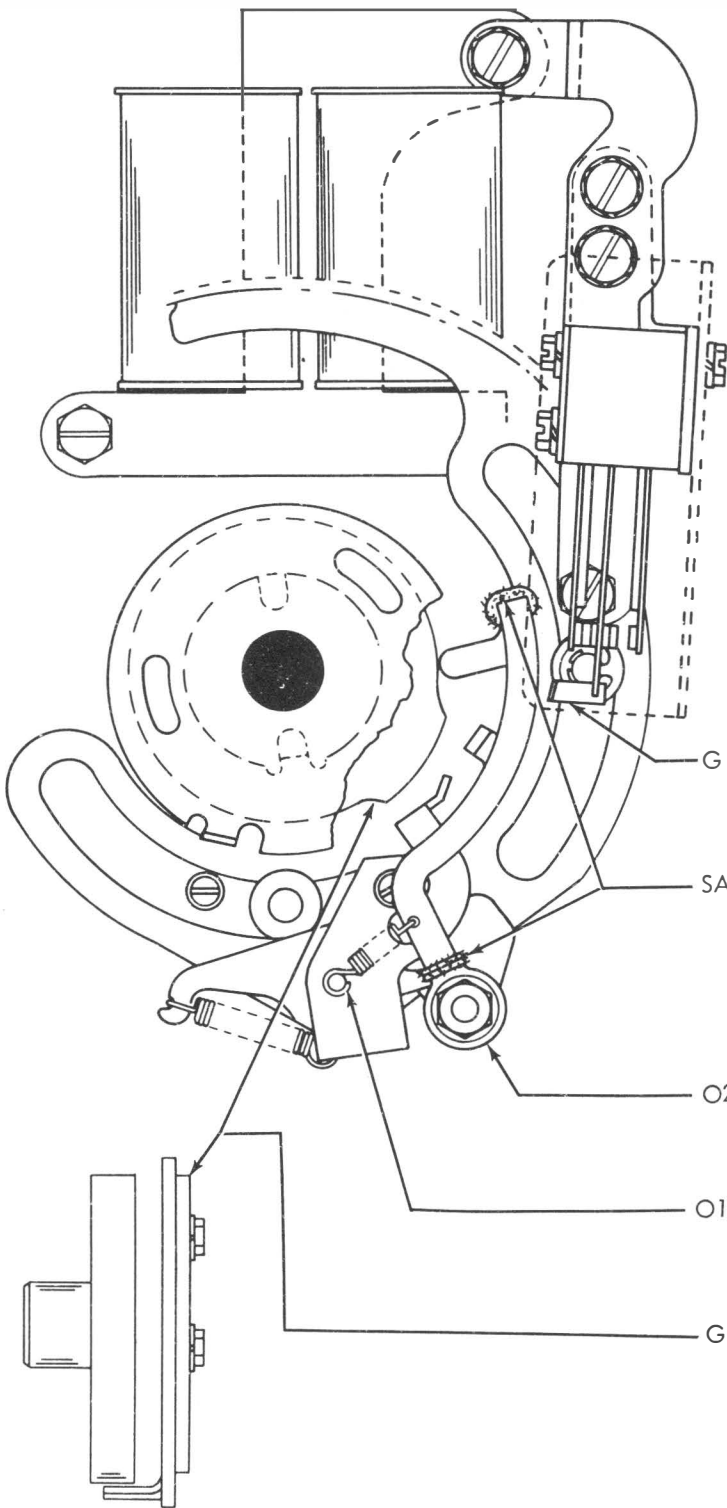

- | | | |
|-----|------------------------------------|-----------------------------------|
| G | METAL FACE TOWARD
OPERATING ARM | SWINGER SPRING
INSULATOR |
| SAT | FELT WASHERS (3) | OPERATING LEVER |
| O2 | BEARING-EACH END | OPERATING LEVER |
| O1 | HOOKS-EACH END | OPERATING LEVER
COILED SPRINGS |
| G | OPERATING SURFACE | CAM |

3. 13 Print Suppression on Functions

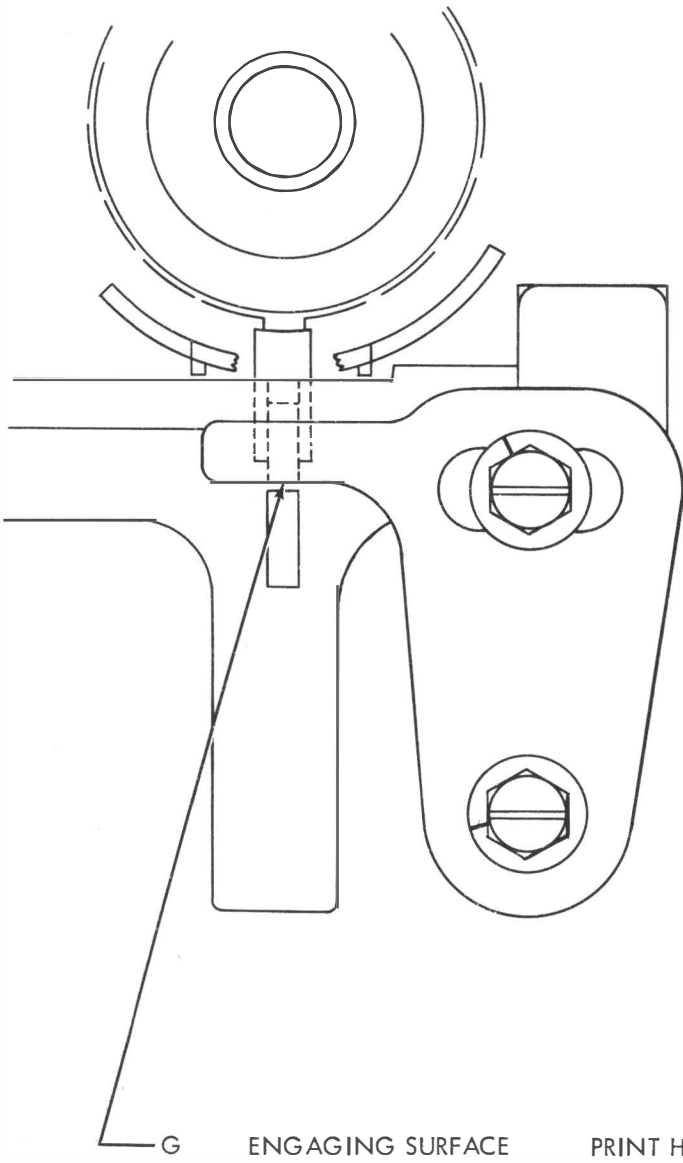

3. 14 Blank Delete Mechanism

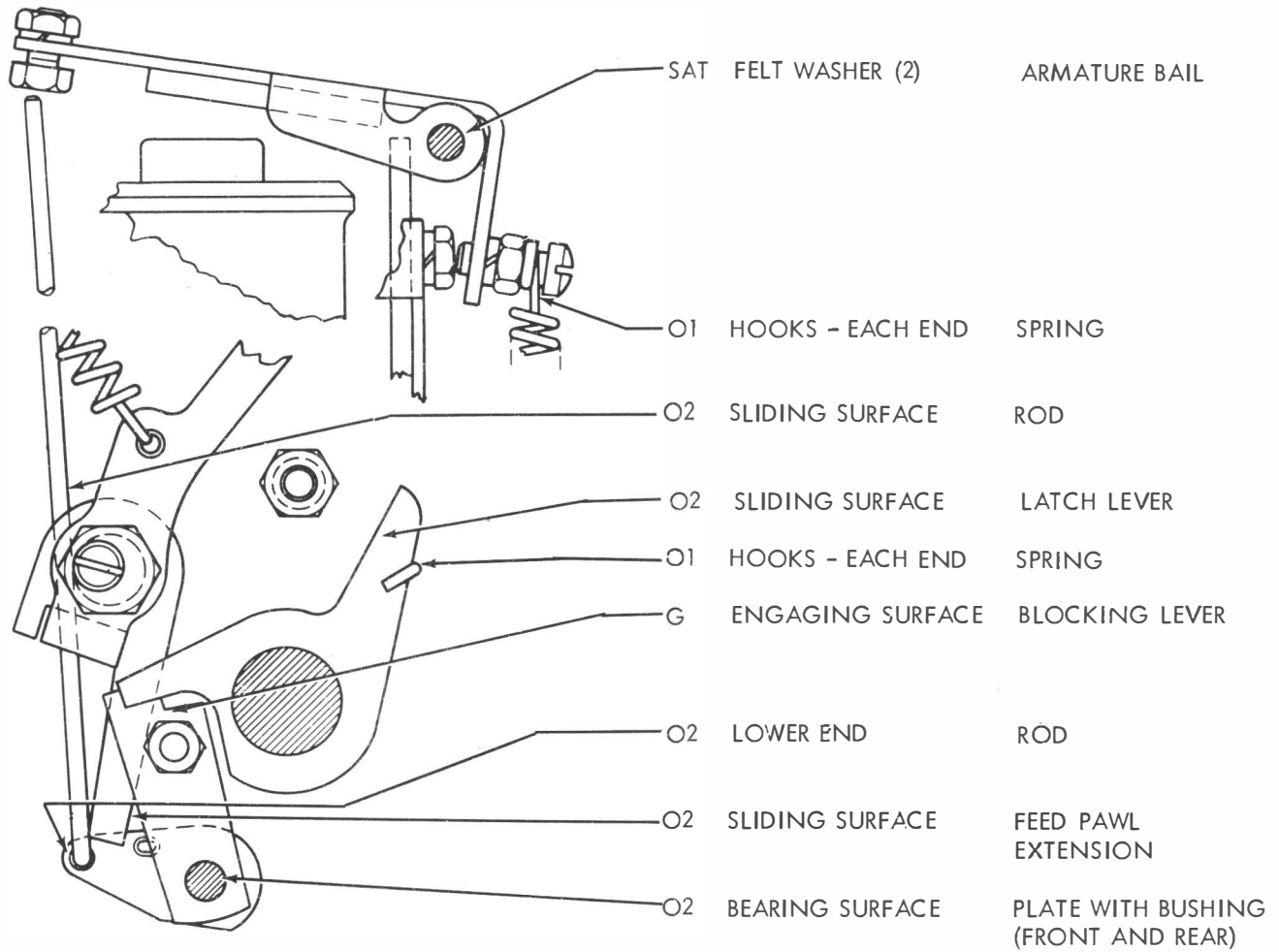

3. 15 Blank Delete Mechanism continued

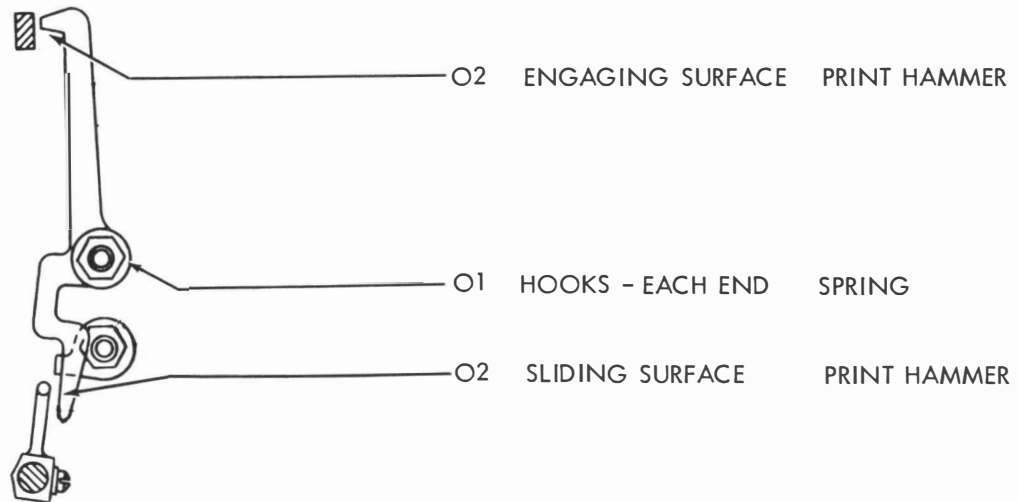
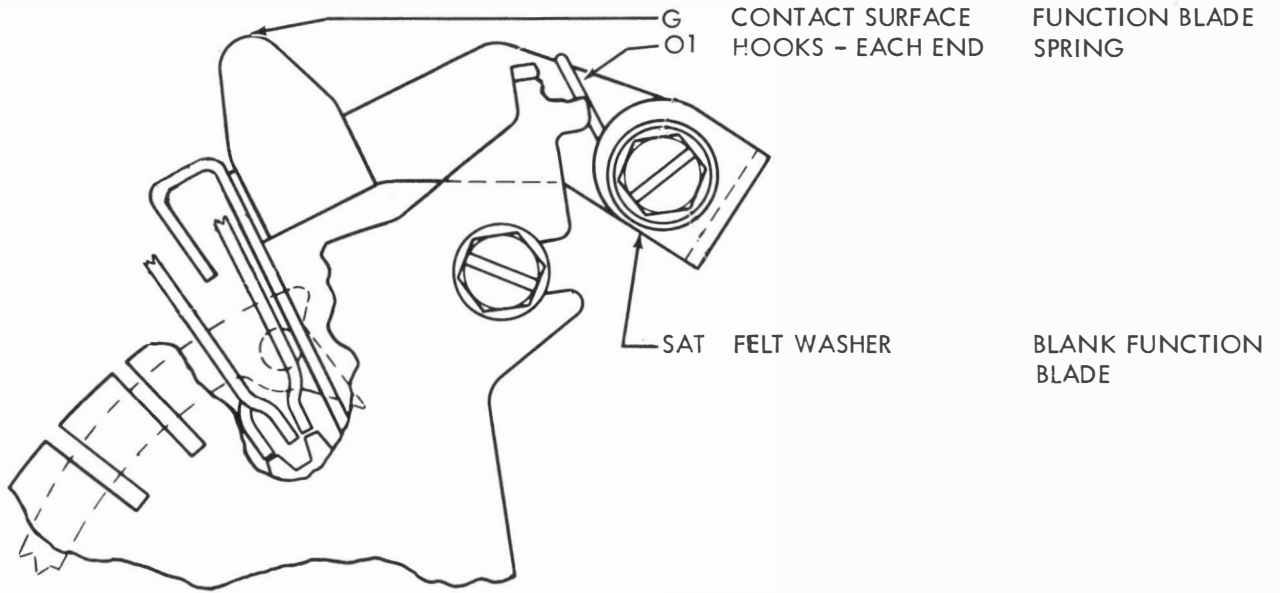

3.16 Letters-Figures Contact Mechanism (Later Design)

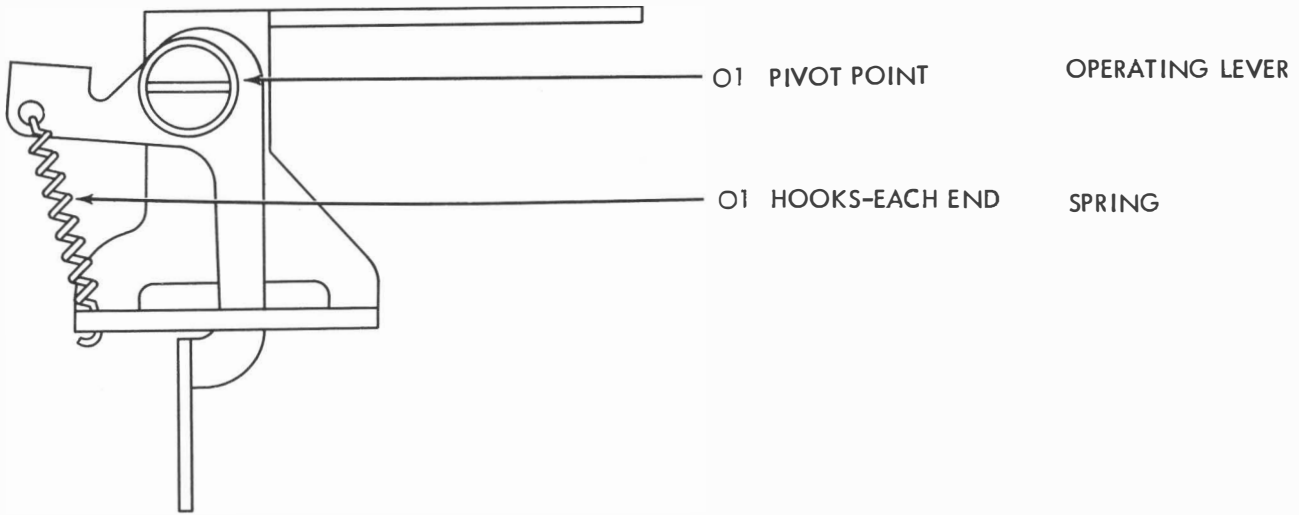

3.17 Timing Contacts

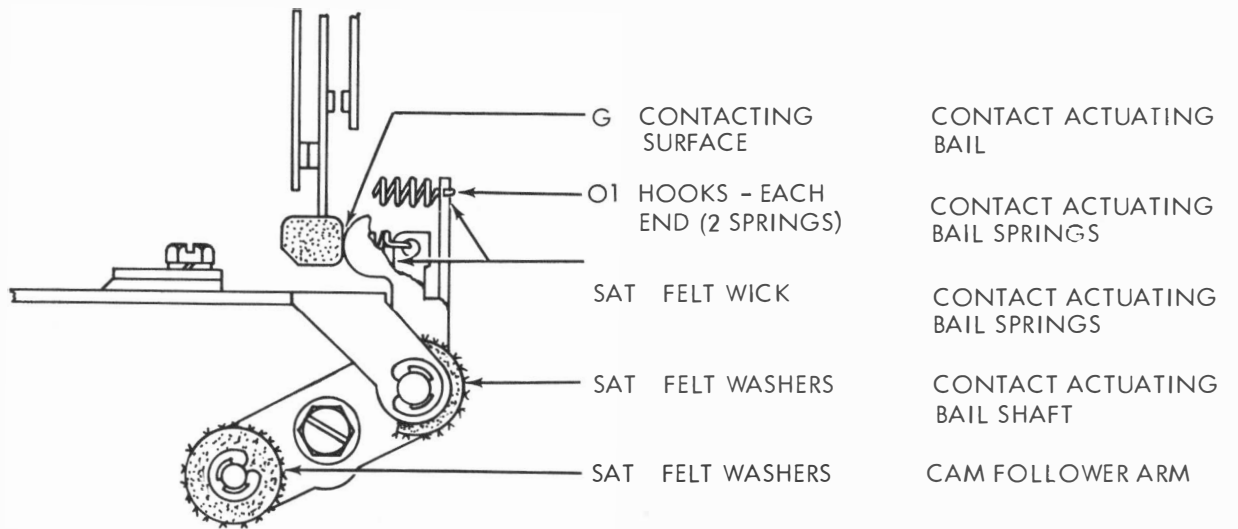

3.18 Code Reading Contacts

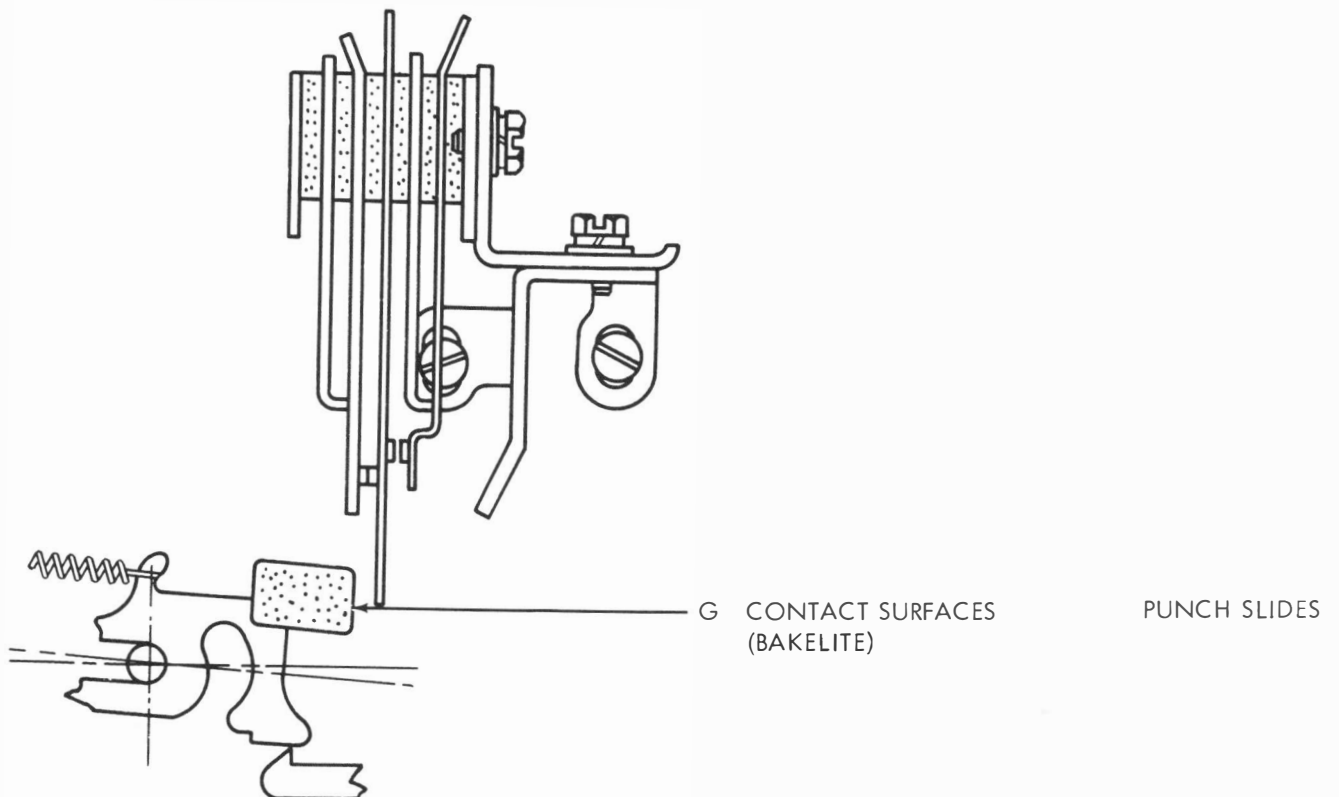

3.19 Manual and Power Drive Backspace Mechanisms (for Chadless Tape)

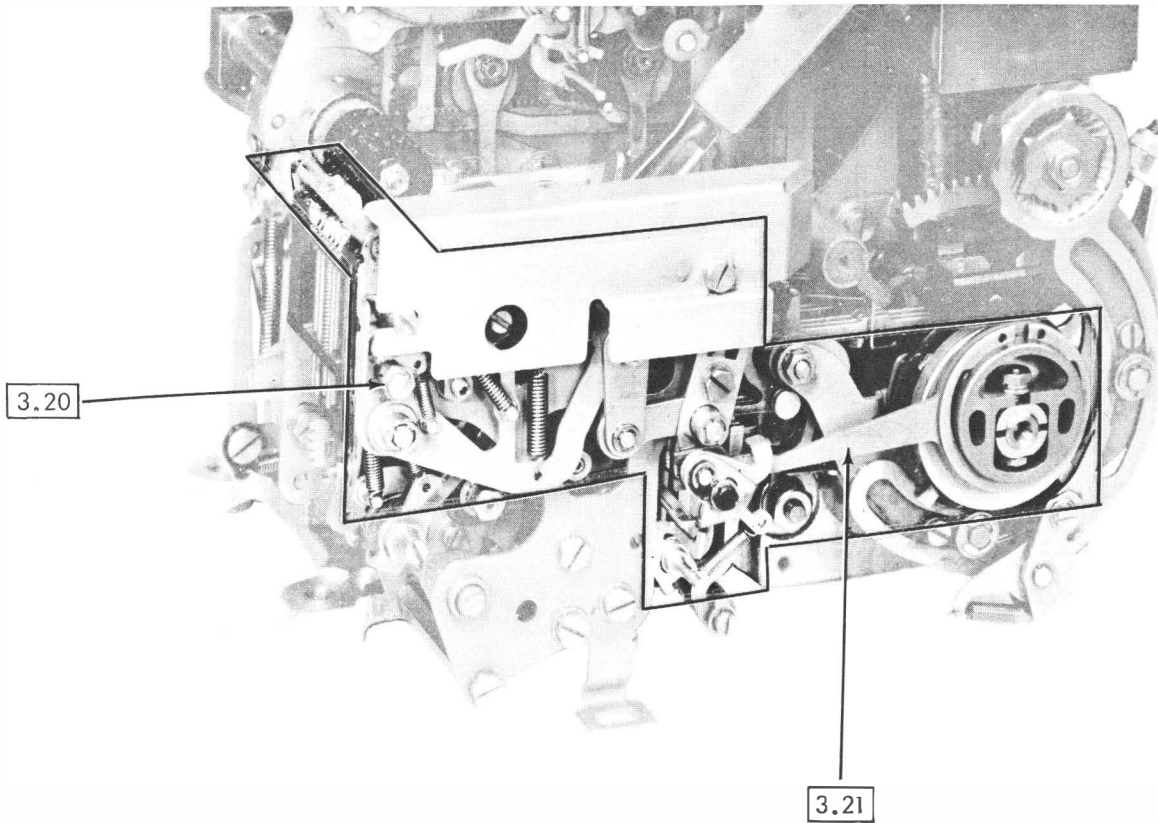

3.20 Backspace Mechanism for Chadless Tape (Manual)

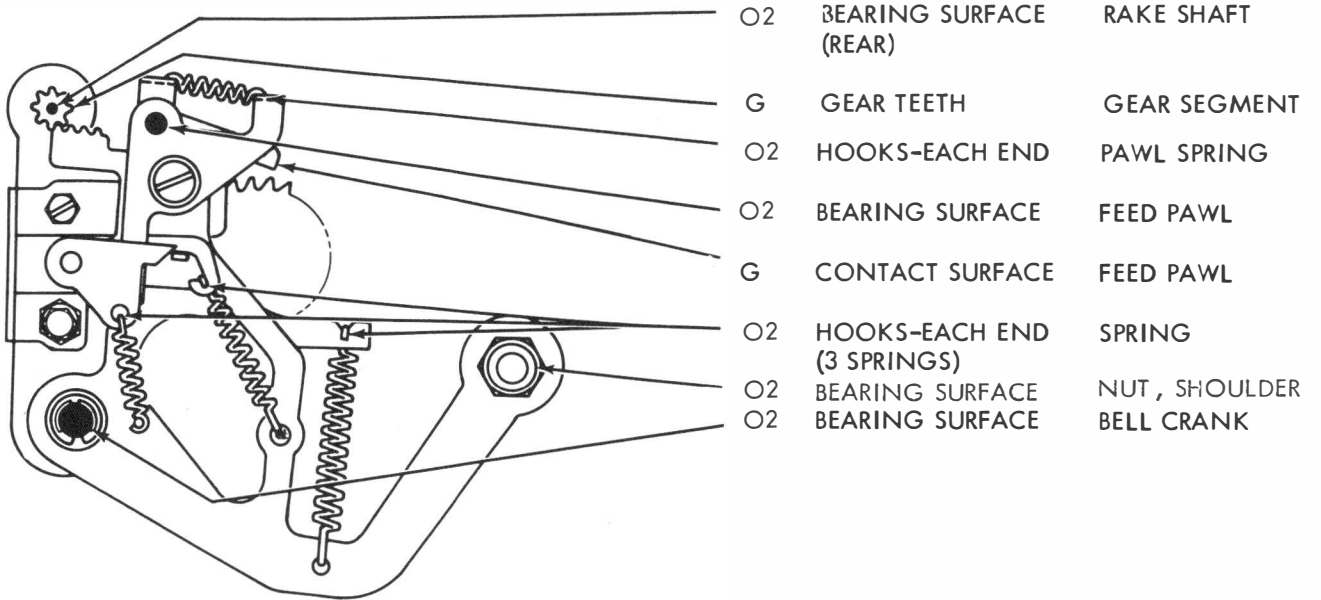

3.21 Backspace Mechanism for Chadless Tape (Power Drive)

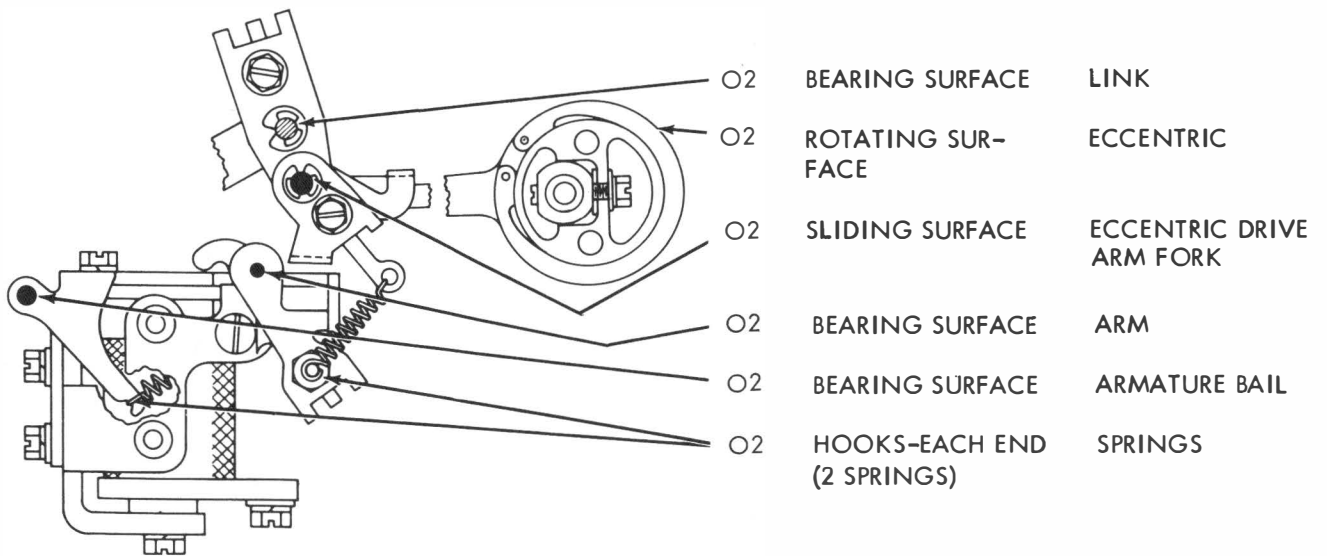

3.22 Backspace Mechanism for Fully Perforated Tape (Power Drive)

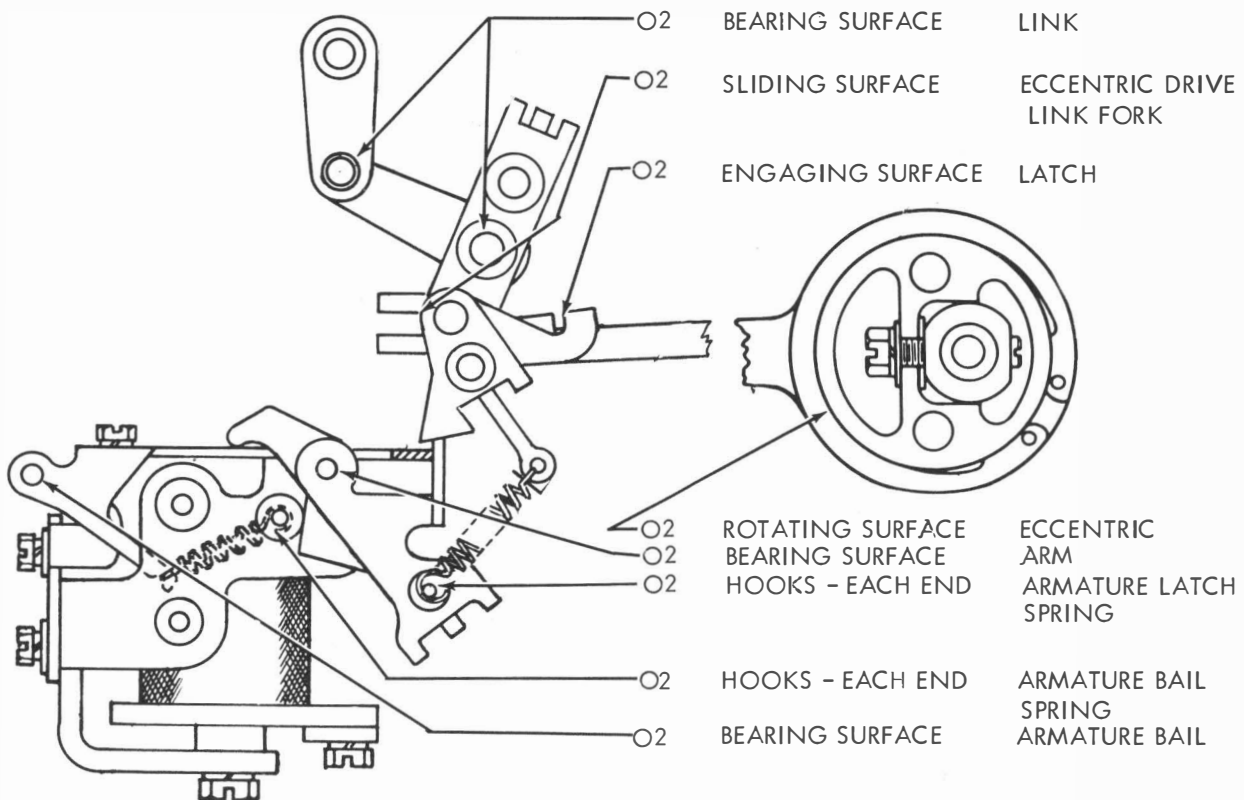
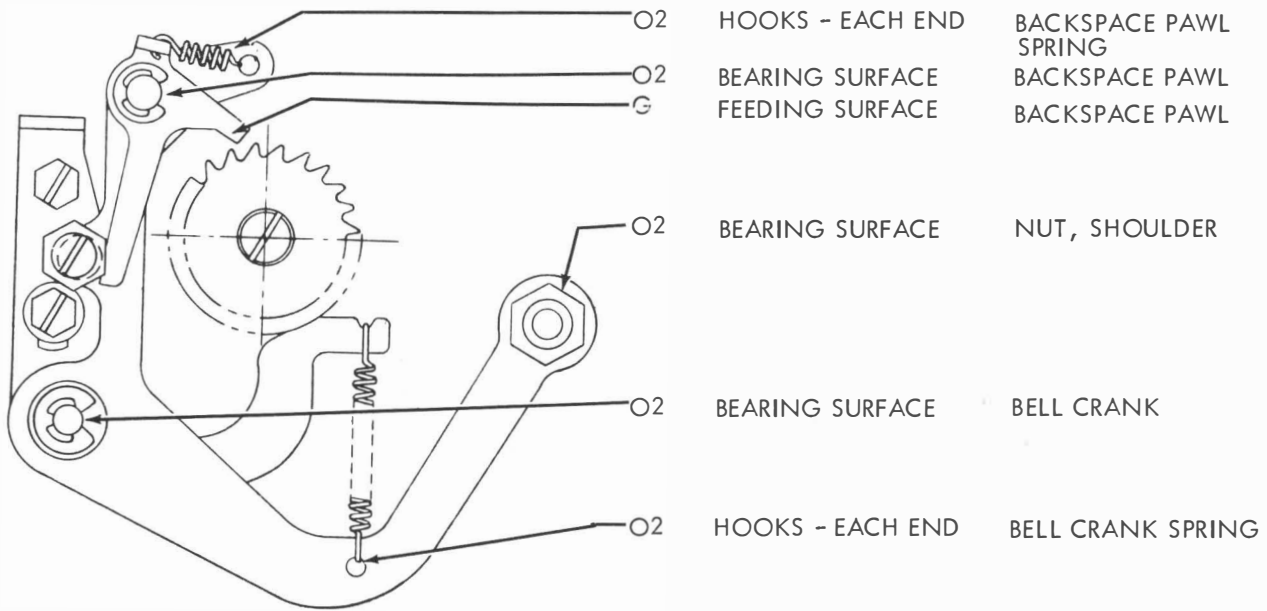

3.23 Time Delay Motor Stop Mechanism

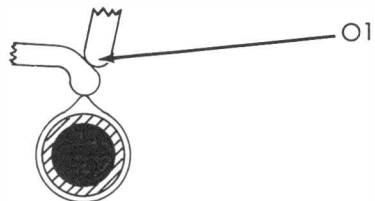
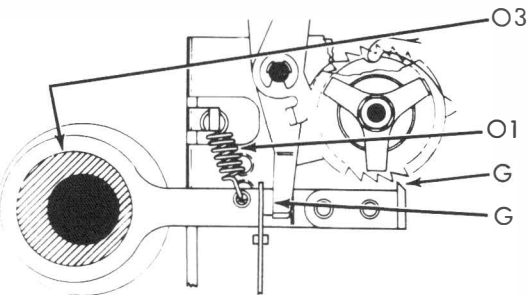
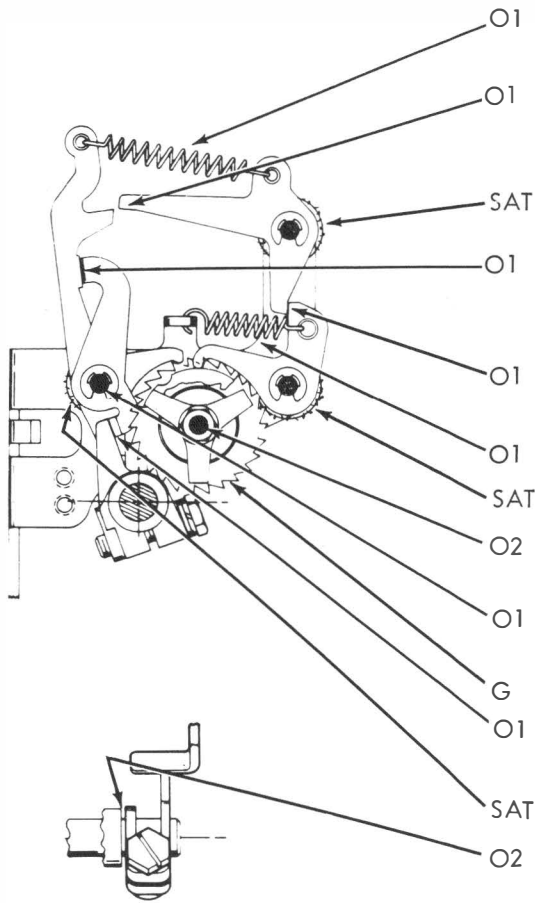

- | | | |
|-----|--------------------------|--|
| O1 | HOOKS-EACH END | SPRING |
| O1 | ENGAGING SURFACE | CONTACT OPERATING PAWL AND LATCH LEVER |
| SAT | FELT WASHERS | LATCH LEVER |
| O1 | ENGAGING SURFACE | BELL CRANK AND CONTACT OPERATING PAWL |
| O1 | ENGAGING SURFACE | LATCH PAWL AND LATCH LEVER |
| O1 | HOOKS-EACH END | SPRING |
| SAT | FELT WASHERS | LATCH PAWL |
| O2 | BEARING SURFACE EACH END | RATCHET WHEEL SHAFT |
| O1 | BEARING SURFACE EACH END | BELLCRANK AND SUPPORTING STUD |
| G | TEETH AND FLANGES | RATCHET WHEELS |
| O1 | ENGAGING SURFACE | CLAMP ARM AND BELLCRANK |
| SAT | FELT WASHERS | CONTACT PAWL |
| O2 | BEARING SURFACE (2) | TIME DELAY RESET SHAFT BUSHING |
| O3 | BEARING SURFACE | ECCENTRIC FOLLOWER DRIVE ARM AND ECCENTRIC |
| O1 | HOOKS-EACH END | SPRING |
| G | ENGAGING SURFACE | DRIVE ARM |
| G | ENGAGING SURFACE | CONTACT OPERATING PAWL AND CONTACT INSULATOR |
| O1 | ENGAGING SURFACE | SELECTOR RESET BAIL TIME DELAY RESET LEVER |

4. EARLIER DESIGN MECHANISMS

4.01 Ribbon Feed Mechanism
(For Later Design
See Par. 2.02.)

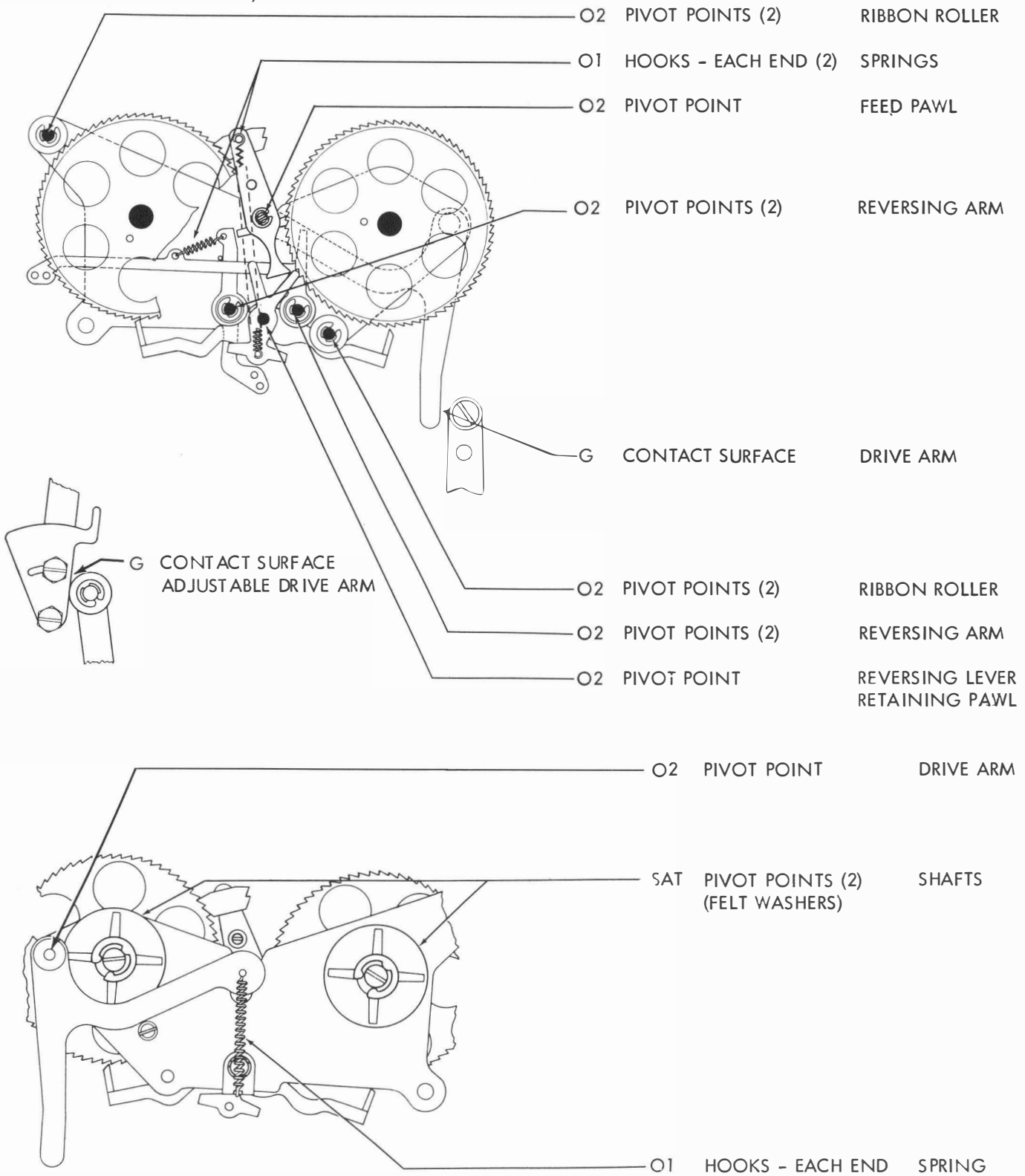

4.02 Remote Control Noninterfering BLANK Tape Feed-Out Mechanism

(For Later Design
See Part 3 Variable Features)

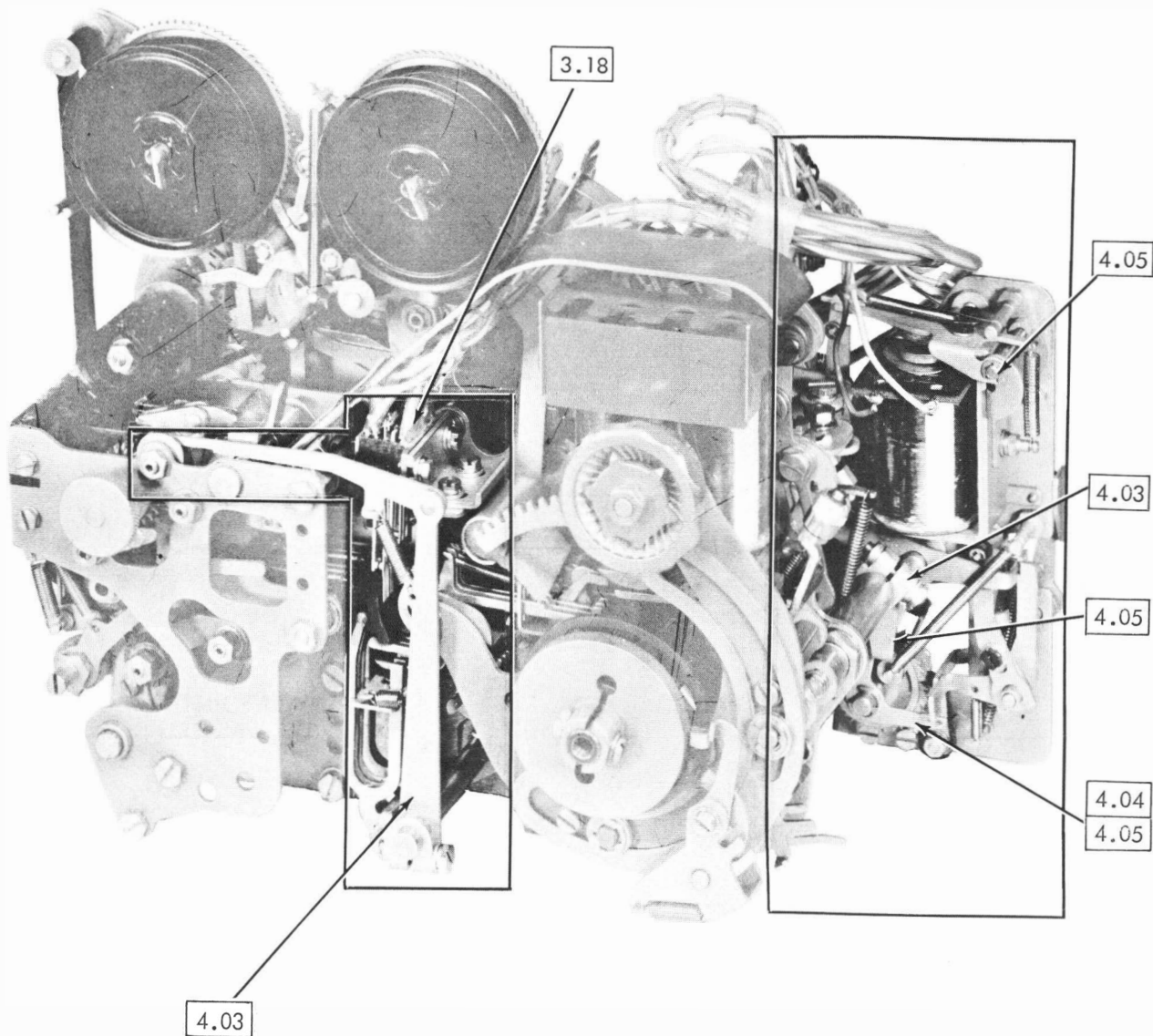

4.03 Remote Control Noninterfering BLANK Tape Feed-Out Mechanism continued

(For Later Design See Part 3 Variable Features)

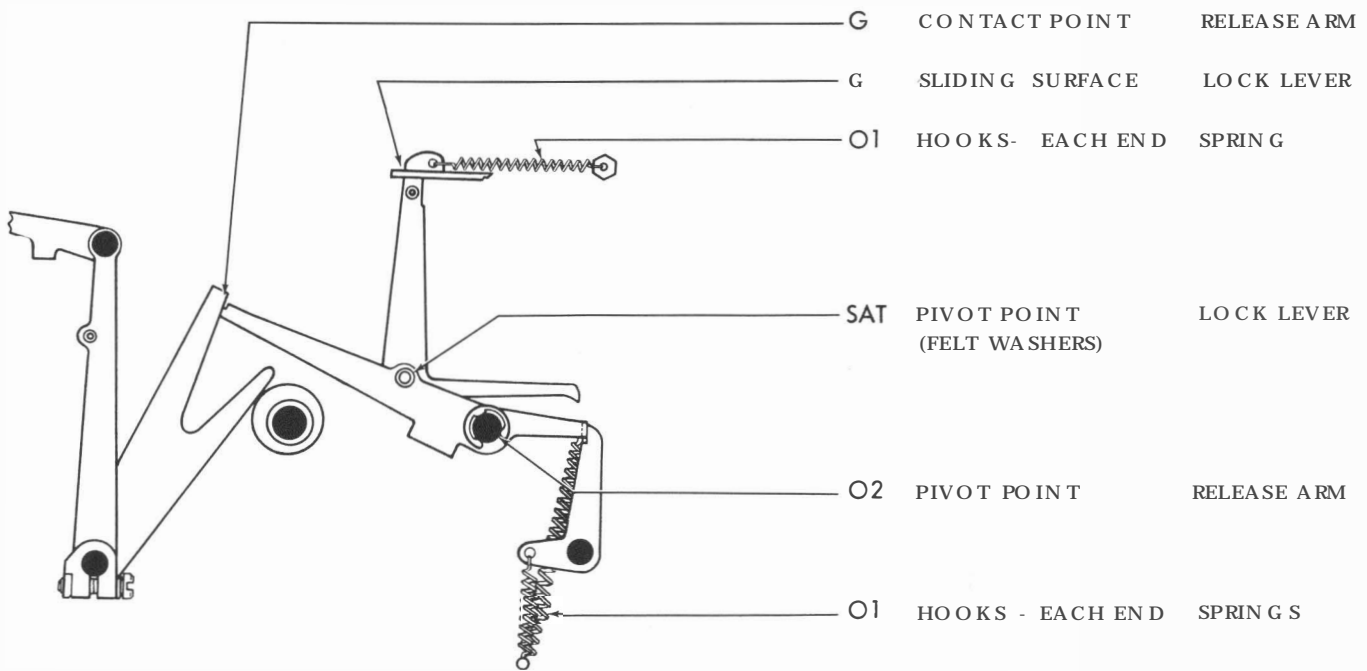
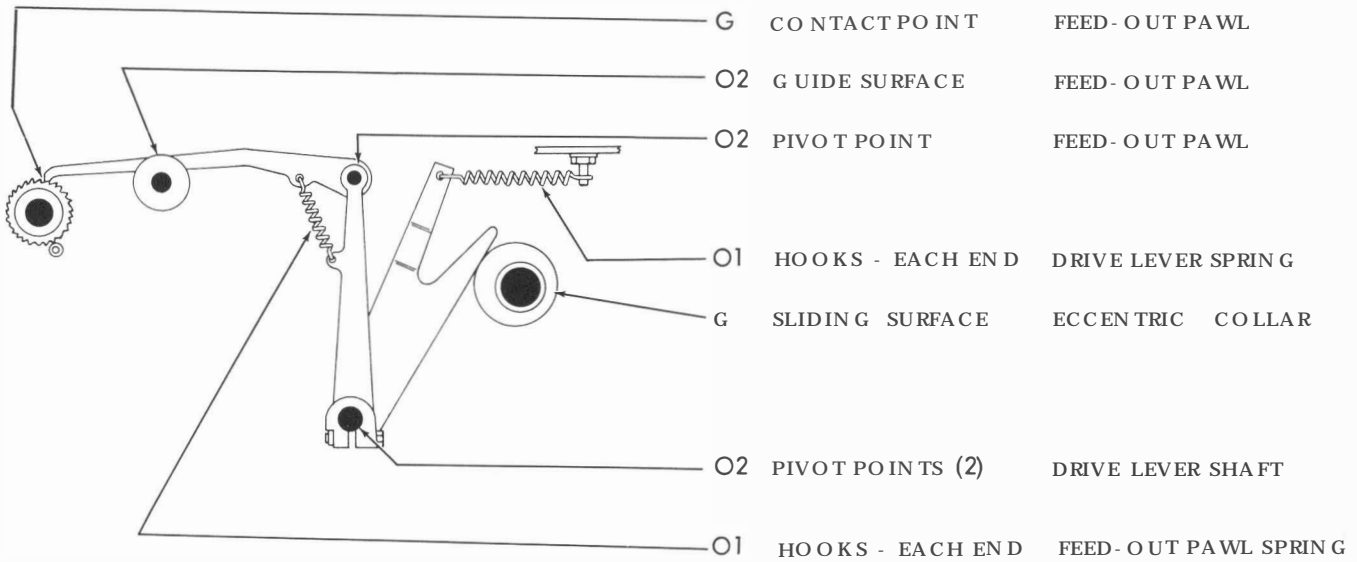

4.04 Remote Control Noninterfering BLANK Tape Feed-Out Mechanism continued
 (For Later Design
 See Part 3 Variable Features)

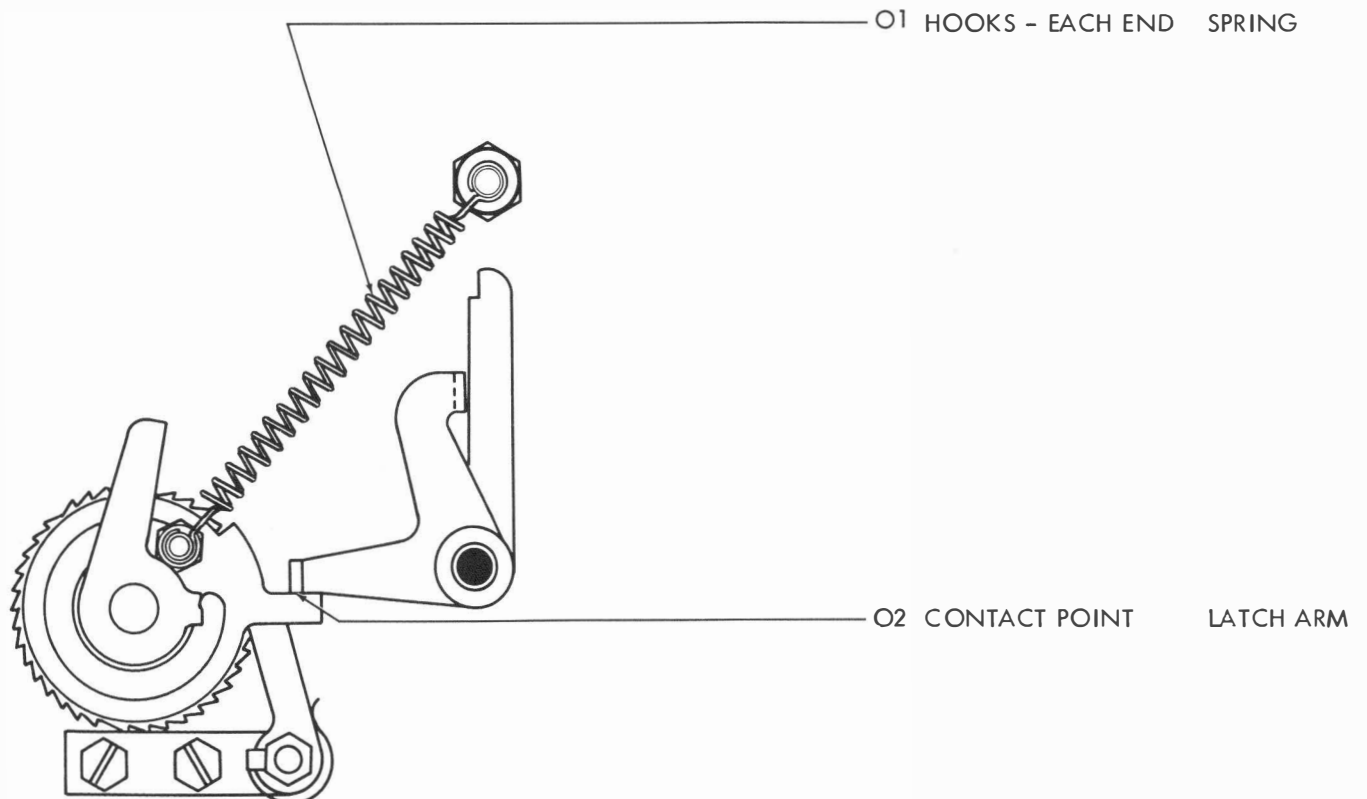
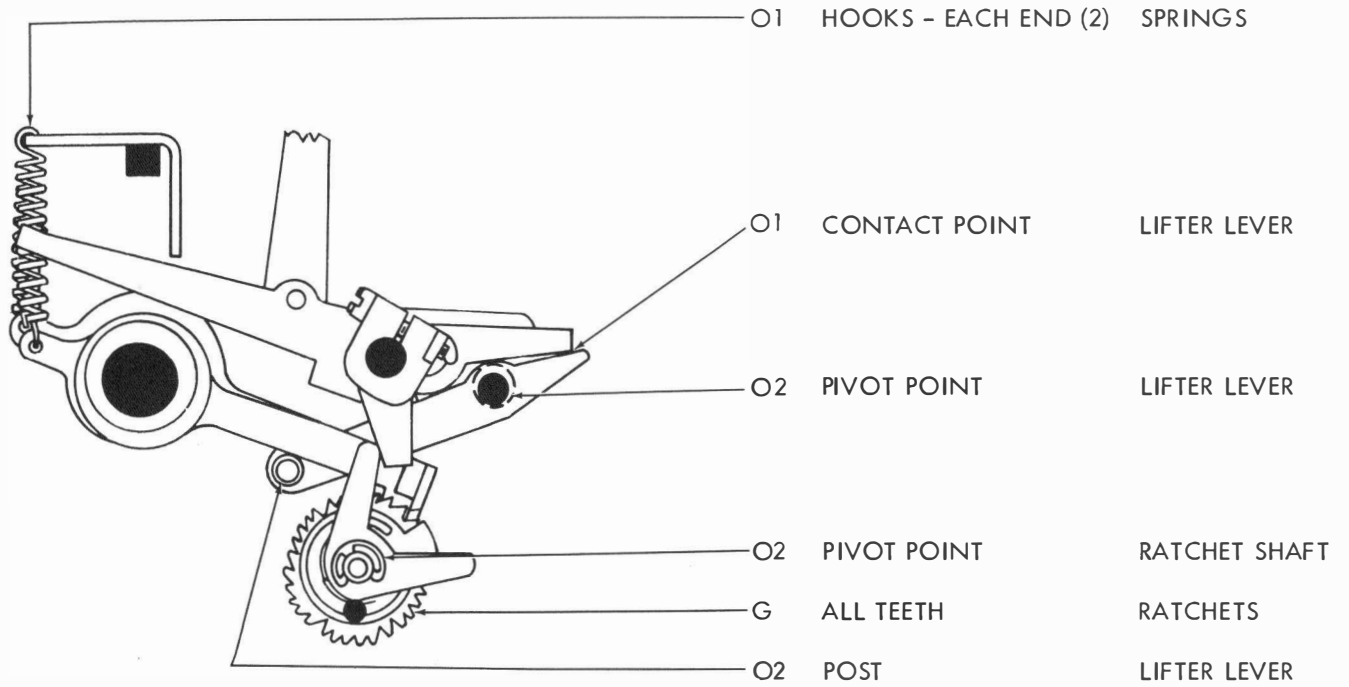

4.05 Remote Control Noninterfering BLANK Tape Feed-Out Mechanism continued
 (For Later Design See Part 3 Variable Features)

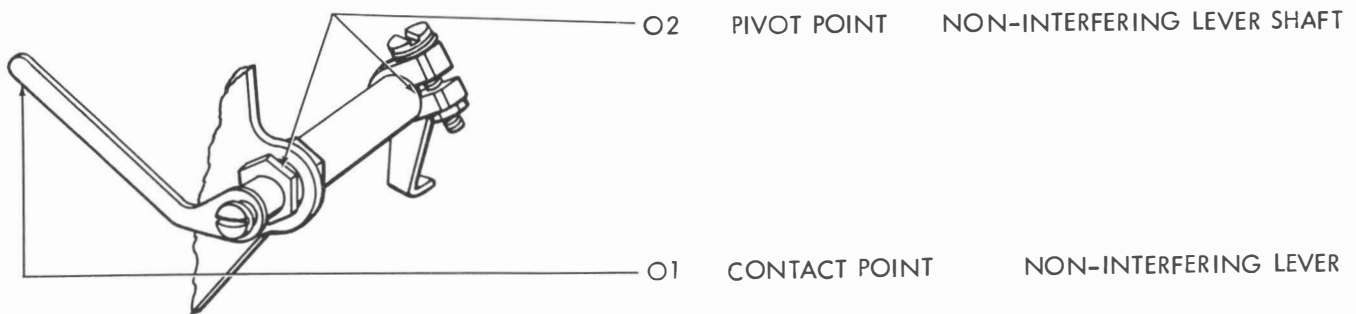
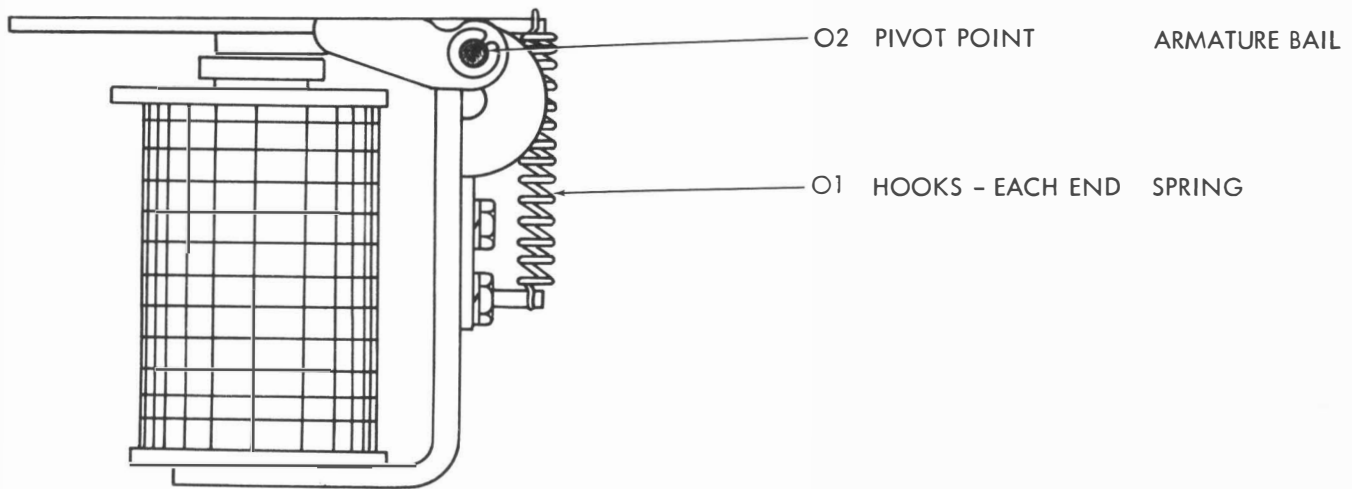
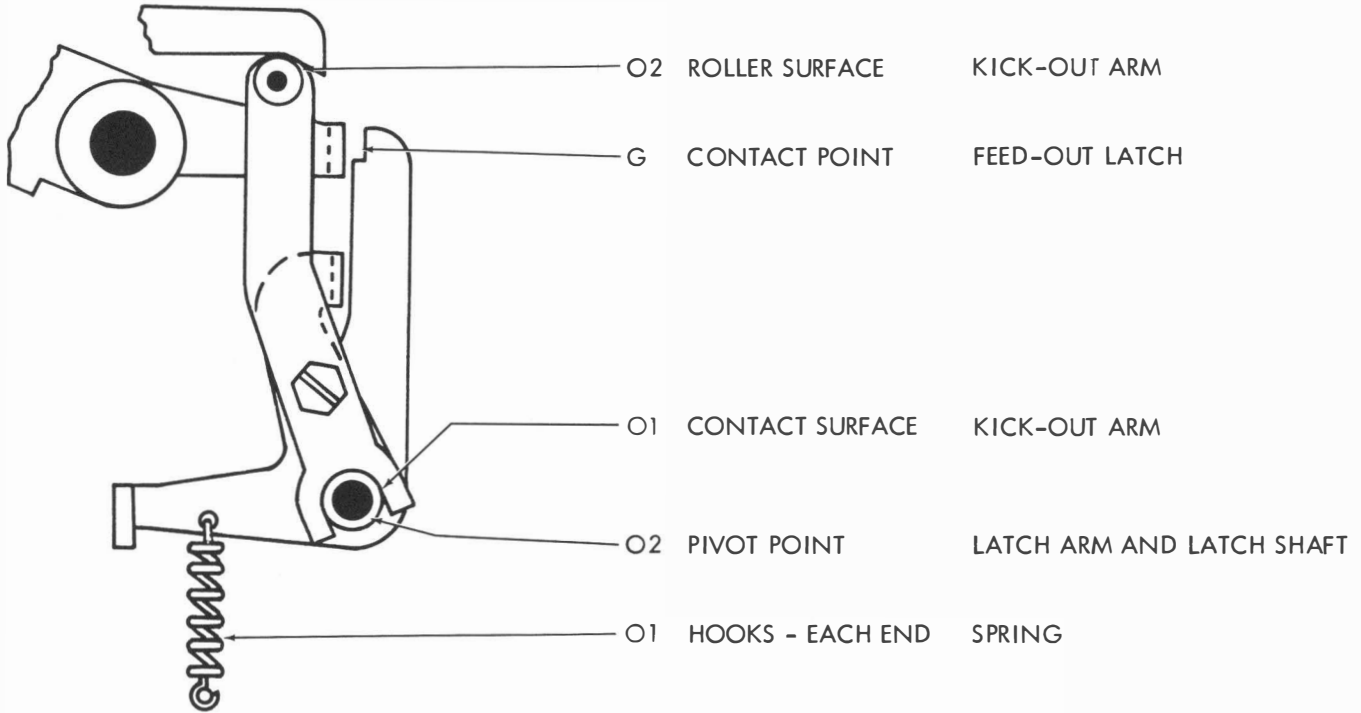

4.06 Remote Control Noninterfering BLANK Tape Feed-Out Mechanism continued
(For Later Design See Part 3 Variable Features)

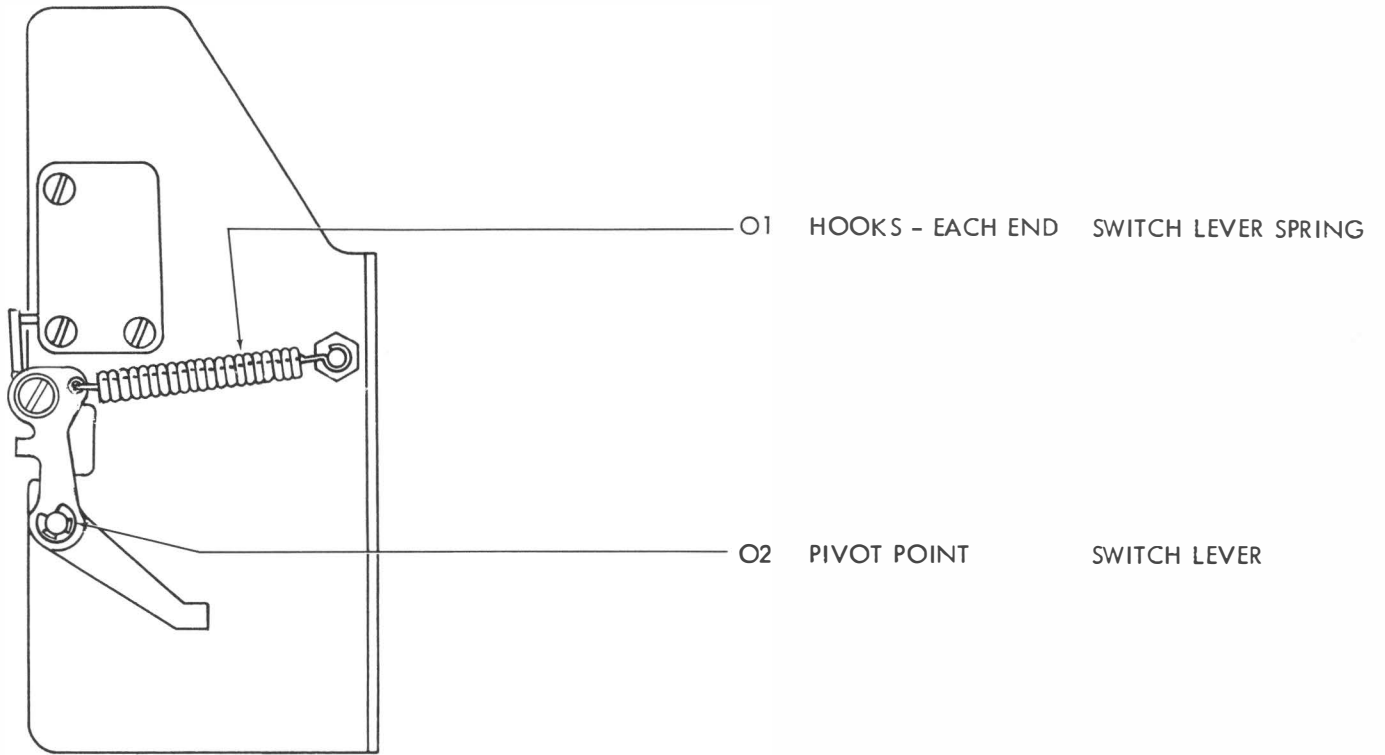

4.07 Remote Control Noninterfering Tape Feed-Out Mechanism continued and Timing Contacts

