

28 TELETYPEWRITER KEYBOARD AND BASE (KSR AND RO)

LUBRICATION

CONTENTS	PAGE	CONTENTS	PAGE
1. GENERAL . . . . .	1	Driving mechanism . . . . .	16
2. LATER DESIGN KEYBOARD . . . . .	3	Keyboard lock bail . . . . .	17
Breaklever . . . . .	4	Stepping pawl . . . . .	16
Codebar . . . . .	5	Stop lever . . . . .	14
Codebar bail . . . . .	9	4. EARLIER DESIGN KEYBOARD . . . . .	25
Codelever . . . . .	4	Answer-back blinding (pulsing)	
Codelever universal bail . . . . .	11	contact . . . . .	33
Contact box . . . . .	7	Answer-back drive mechanism . . . . .	34, 35
Electrical line break . . . . .	10	Codebar . . . . .	28, 29
Function clutch . . . . .	7	Codebar bail and eccentric follower . . . . .	29
Intermediate gear . . . . .	8	Codelever . . . . .	25
Keyboard lock . . . . .	4	Codelever bail . . . . .	28
Keylever . . . . .	3	Contact box . . . . .	28
Local carriage return . . . . .	5	Intermediate gears . . . . .	30
Local line feed . . . . .	8	Intermediate levers . . . . .	31
Local paper feed-out . . . . .	11	Keyboard lock . . . . .	27
Lockbar latch . . . . .	11	Keyboard selector . . . . .	29
Locking bail . . . . .	9	Local carriage return . . . . .	26
Margin indicator . . . . .	8	Local line feed . . . . .	26
Nonrepeat lever . . . . .	6	Margin indicator . . . . .	27
Shaft . . . . .	8	Paper feed-out . . . . .	33
Spacebar . . . . .	3	Repeat on space . . . . .	36
Transfer bail . . . . .	7	Signal generator clutch . . . . .	32
Transfer lever . . . . .	6	Signal generator mechanism . . . . .	30, 32
Universal bail latchlever . . . . .	10	Signal generator shaft . . . . .	31
3. VARIABLE FEATURES (KEYBOARD) . . . . .	12	Signal line break (electrical) . . . . .	36
Blinding (pulsing) contact		Time delay mechanism . . . . .	32
cam follower . . . . .	19	5. RECEIVE-ONLY (RO) BASE . . . . .	37
Form feed-out . . . . .	21	Signal line break . . . . .	37
Local backspace . . . . .	12	1. GENERAL	
Local reverse line feed . . . . .	12	1.01 This section provides specific lubrication	
Lockbar contact . . . . .	22	procedures for the 28 teletypewriter key-	
Offline contacts . . . . .	23	board and base (KSR and RO bases) including var-	
Remote control gear shift . . . . .	20	iable features. It is being reissued to conform to	
Repeat on space mechanism . . . . .	22	more of a standard format, and to include recent	
Solenoid bail . . . . .	23	engineering changes and additions. Since this is	
Switch operating lever . . . . .	24	a general revision, marginal arrows ordinarily	
Universal keyboard switch . . . . .	24	used to indicate changes have been omitted.	
Variable speed drive - speed			
selecting mechanism . . . . .	18, 19		
Answer-Back Mechanisms			
Armature . . . . .	13		
Codebars and sensing levers . . . . .	13, 15		

SECTION 573-116-701

1.02 The photographs show the paragraph numbers referring to particular line drawings of mechanisms, and where these mechanisms are located on the unit. The line drawings are provided to illustrate the points of lubrication and the quantity of lubricant to be used. Parts in the line drawings are shown in an upright position unless otherwise specified.

1.03 The symbols on the illustrations indicate lubrication as follows:

- O1 Apply 1 drop of oil.
- O2 Apply 2 drops of oil.
- O3 Apply 3 drops of oil.
- G Apply thin film of grease.
- SAT Saturate (felt oilers, washers, wicks) with oil.

1.04 Use TP88970 (KS7470) oil at all locations where the use of oil is indicated. Use TP88973 (KS7471) grease on all surfaces where grease is indicated.

1.05 Lubricate the unit just prior to placing it in service. After a few weeks in service, relubricate to make certain that all points re-

ceive lubrication. The following lubrication schedule should be followed thereafter:

<u>Operating Speed (WPM)</u>	<u>Lubrication Intervals</u>
60	3000 hours or 1 year*
75	2400 hours or 9 months*
100	1500 hours or 6 months*

\*Whichever occurs first.

1.06 All spring eyes, spring wicks and felt oilers should be saturated. The friction surfaces of all moving parts should be thoroughly lubricated. However, over-lubrication, which will permit oil or grease to drip or be thrown on other parts should be avoided.

CAUTION: SPECIAL CARE MUST BE TAKEN TO PREVENT ANY OIL OR GREASE FROM GETTING BETWEEN ELECTRICAL CONTACTS.

1.07 Apply a thick film of grease to all gears. Apply oil to all cams, including the camming surfaces of each clutch discs.

2. LATER DESIGN KEYBOARD

2.01 Keyboard - Bottom View

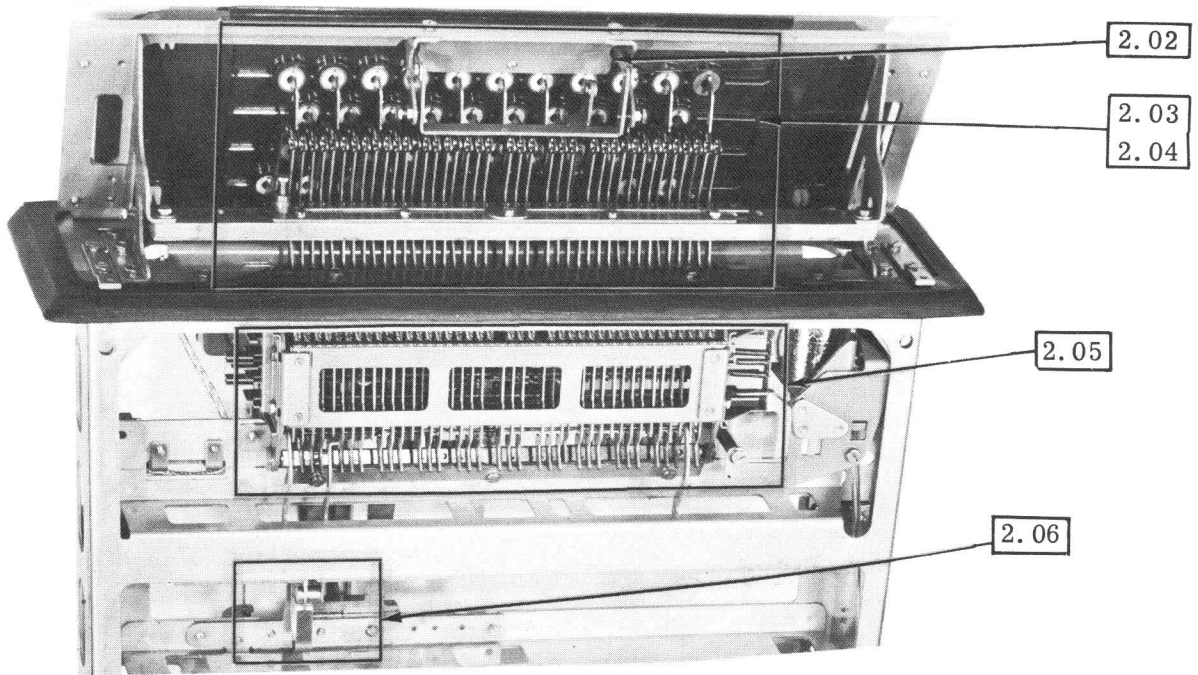

2.02 Spacebar

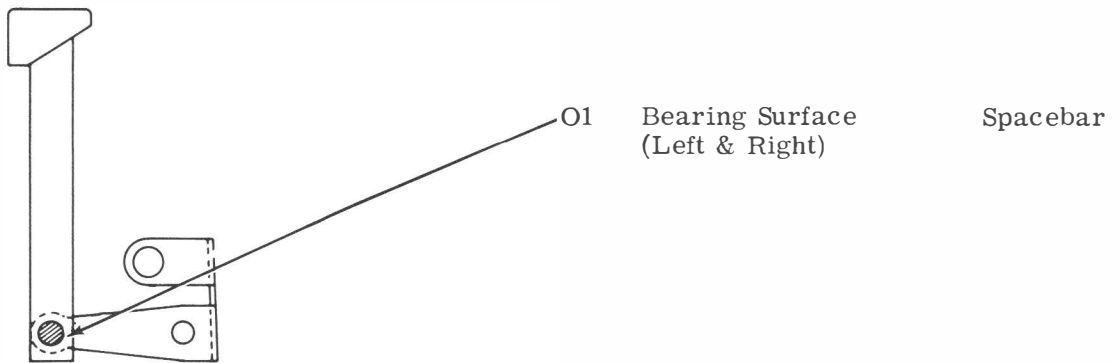

2.03 Keylever

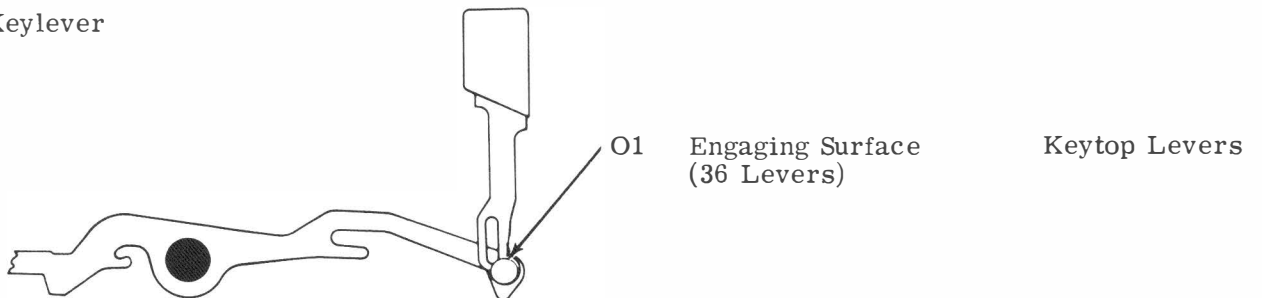

SECTION 573-116-701

2.04 Breaklever

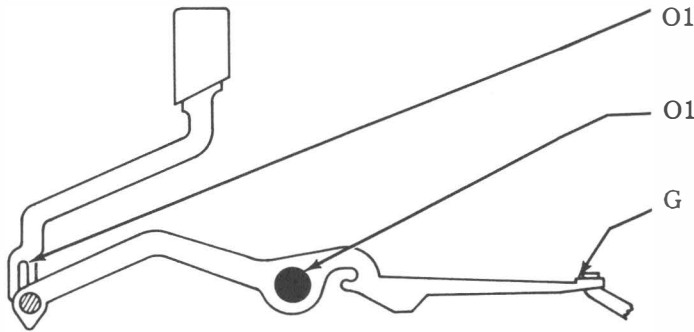

- O1 Engaging Surface Break Keylever
- O1 Bearing Surface Function Lever
- G Contact Surface Breaklever

2.05 Codelever

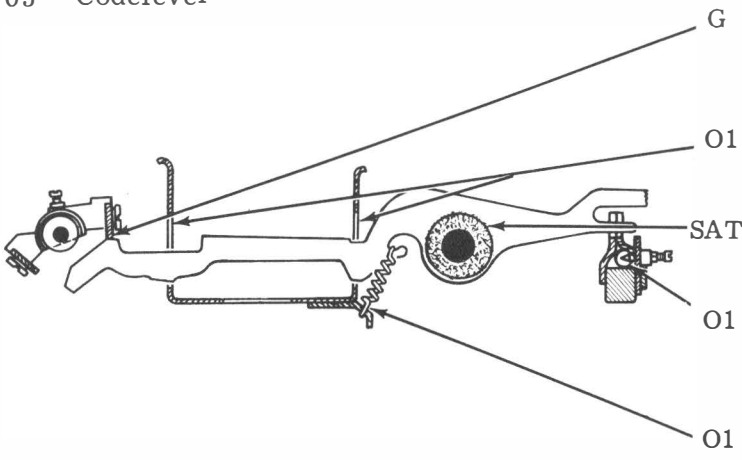

- G Contacting Surface (32 Levers) Codelever Universal Bail
- O1 Guide Slots (32 Levers) Codelevers
- SAT Felt Washers (6 Washers) Codelever Shaft
- O1 Bearing Surface (32 Wedges) Lock Ball Track
- O1 Hooks - Each End (40 Springs) Spring

2.06 Keyboard Lock

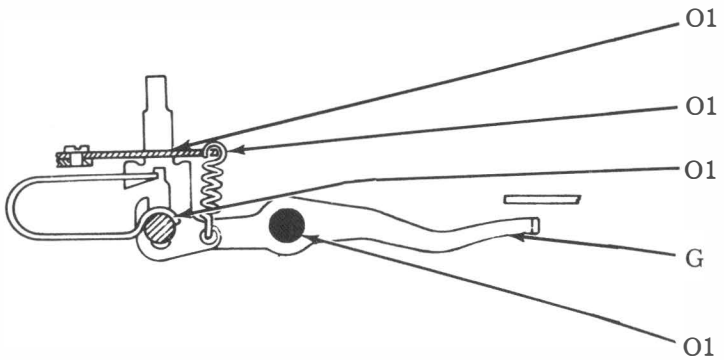

- O1 Guide Slot Keyboard Lock Plunger
- O1 Hooks - Each End Spring
- O1 Bearing Surface Keyboard Locklever
- G Engaging Surface Keyboard Lock Function Lever
- O1 Bearing Surface Function Bail

2.07 Keyboard - Top View

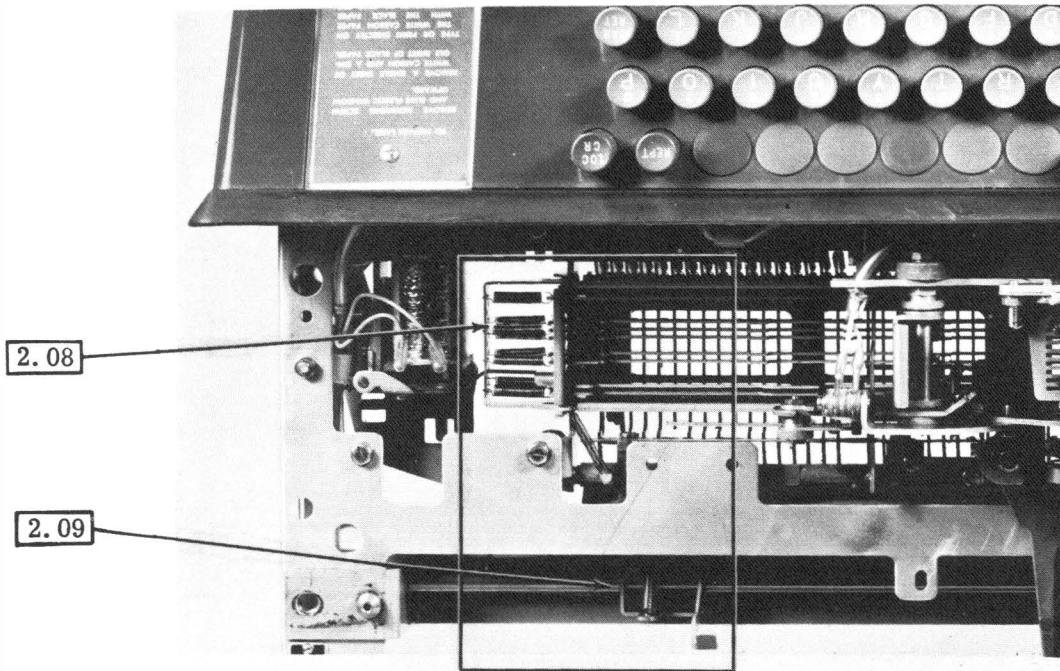

2.08 Codebar

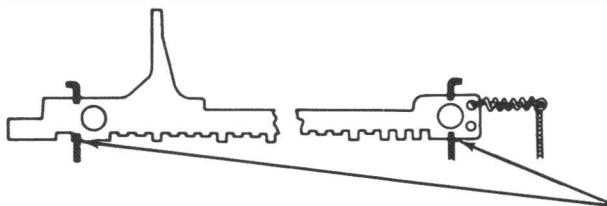

O1 Hooks - Each End Spring

O1 Guide Slots (Left and Right - Top and Bottom) Codebar Guides

2.09 Local Carriage Return

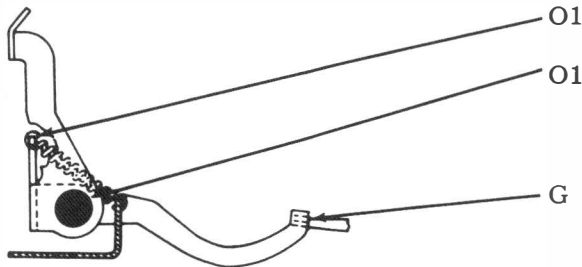

O1 Hooks - Each End Spring

O1 Bearing Surface ( 2 Places) Local Carriage Return Function Bail

G Engaging Surface Local Carriage Return Function Lever

2.10 Signal Generator Mechanism - Top Rear View

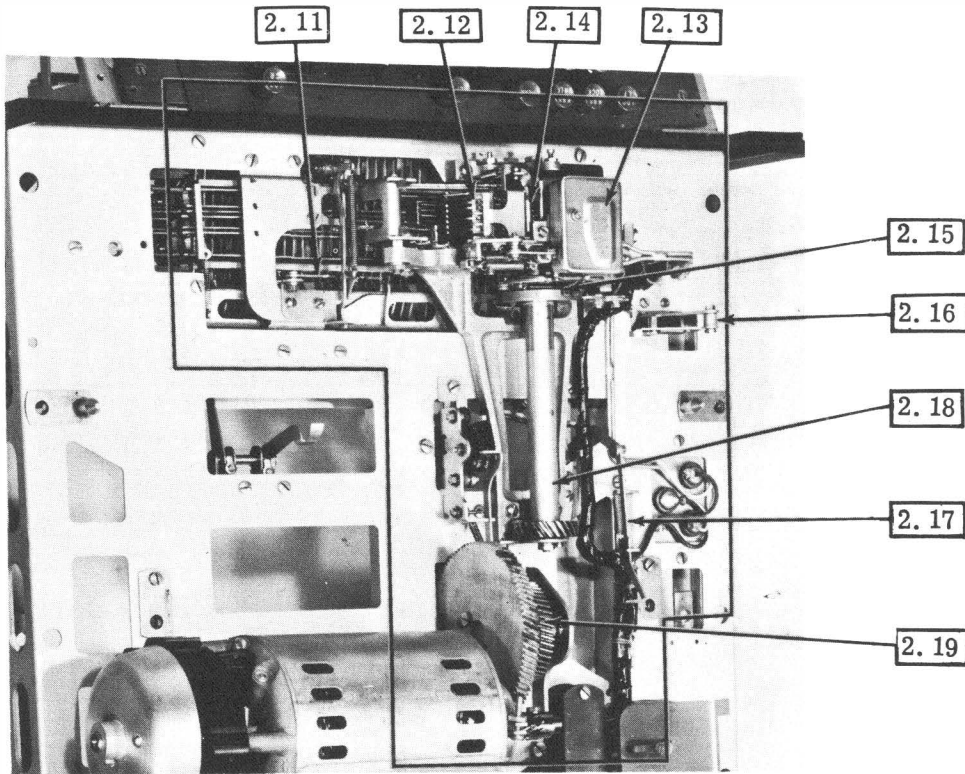

2.11 Nonrepeat Lever

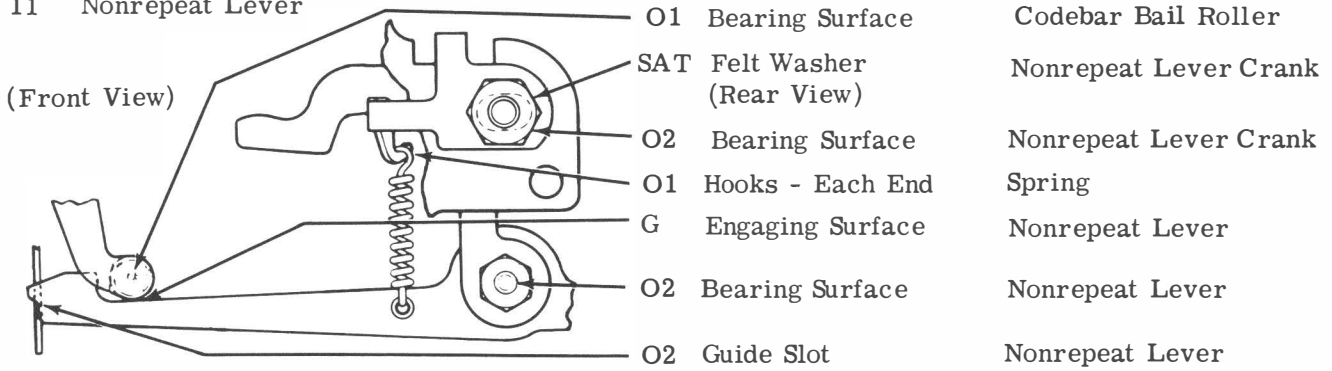

2.12 Transfer Lever

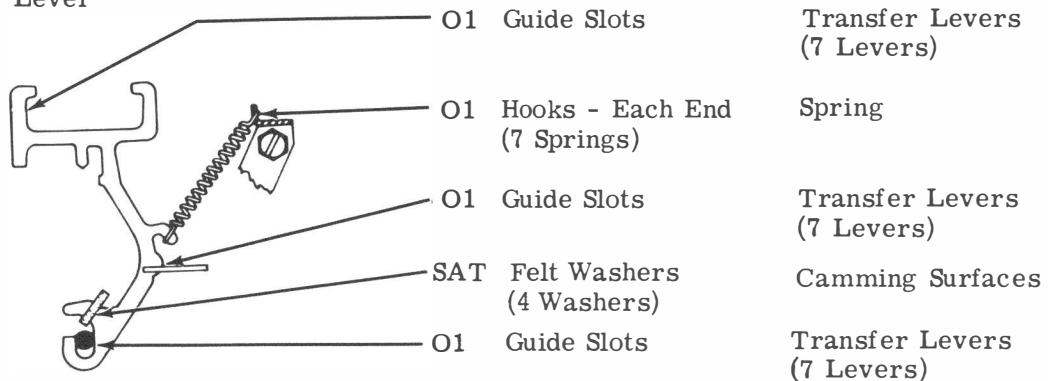

2.13 Contact Box

Note: Contact box cover must be removed prior to lubrication. To remove contact box cover, remove securing nut and lockwasher.

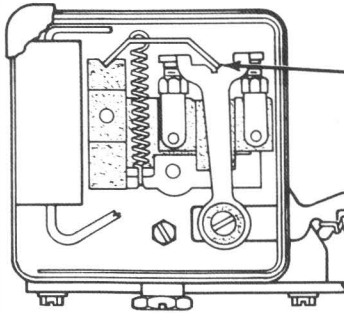

G Engaging Surface Contact Toggle

O1 Hooks - Each End Spring

**CAUTION: GREASE SPARINGLY - KEEP CONTACTS FREE OF OIL OR GREASE.**

2.14 Transfer Bail

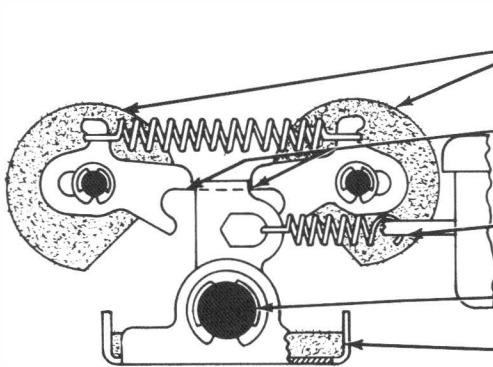

SAT Felt Washers (2 Washers) Latches

G Engaging Surface Transfer Bail

O1 Hooks - Each End (2 Springs) Spring

O2 Bearing Surface Transfer Bail

SAT Oil Wick Transfer Bail

2.15 Function Clutch

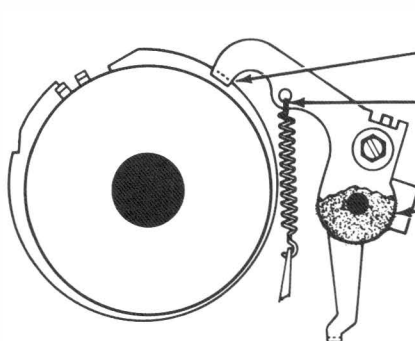

O2 Latching Surface Clutch Stop Lever and Clutch Latchlever

O1 Hooks - Each End (2 Springs) Spring

SAT Felt Washers (2 Front & Rear) Clutch Tripbail

2. 16 Margin Indicator

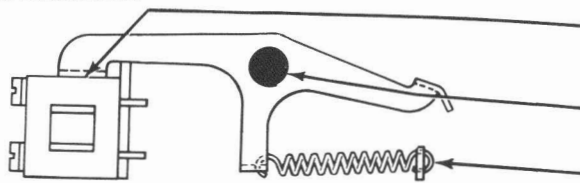

- O1 Engaging Surface (See Note) Margin Indicator Switch
- O1 Bearing Surface Switch Lever
- O1 Hooks - Each End Spring

Note: Engaging surface of switch and lever shall not be lubricated if switch has a nylon actuator.

2. 17 Local Line Feed

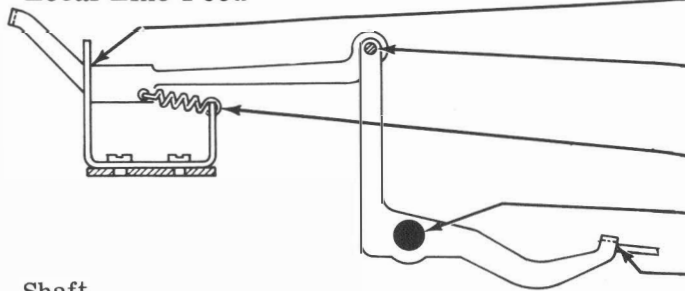

- O2 Guide Slot Local Line Feed Trip Link
- O1 Bearing Surface Local Line Feed Function Lever
- O1 Hooks - Each End Spring
- O1 Bearing Surface Function Bail
- G Engaging Surface Local Line Feed Function Lever

2. 18 Shaft

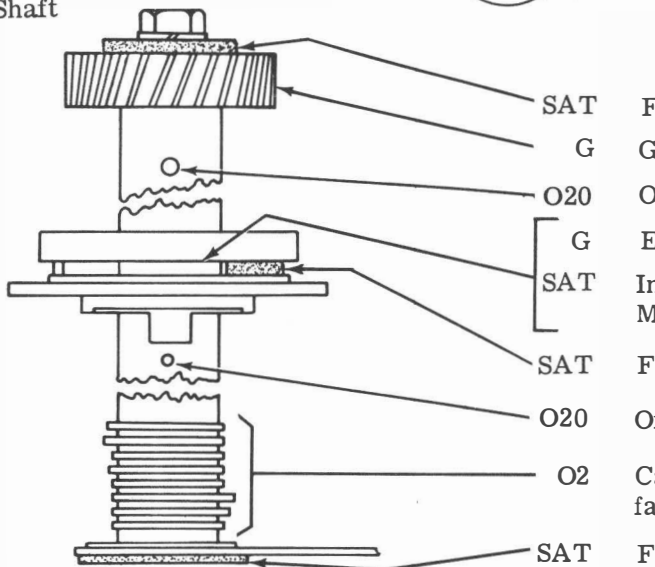

- SAT Felt Washer Signal Generator Shaft
- G Gear Teeth Signal Generator Shaft
- O20 Oil Hole Signal Generator Shaft
- G Each Hook Shoe Lever Spring
- SAT Internal Mechanism Keyboard Clutch
- SAT Felt Wick
- O20 Oil Hole Signal Generator Cam
- O2 Camming Surface Each Cam Signal Generator Cam
- SAT Felt Washer Signal Generator Shaft

2. 19 Intermediate Gear

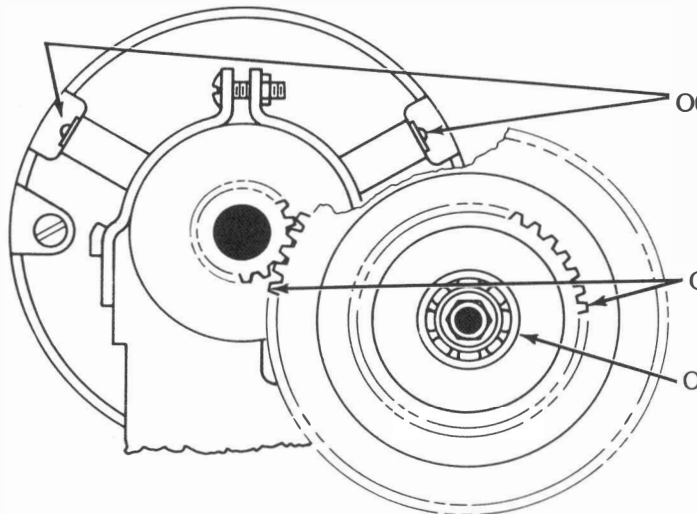

- O6 Each Oiler (Total 4 Oilers) Motor Shaft
- G Teeth (2 Gears) Intermediate Gears
- O2 Ball Bearing (2 Bearings) Intermediate Gear Shaft



2.20 Signal Generator Mechanism - Right Top View

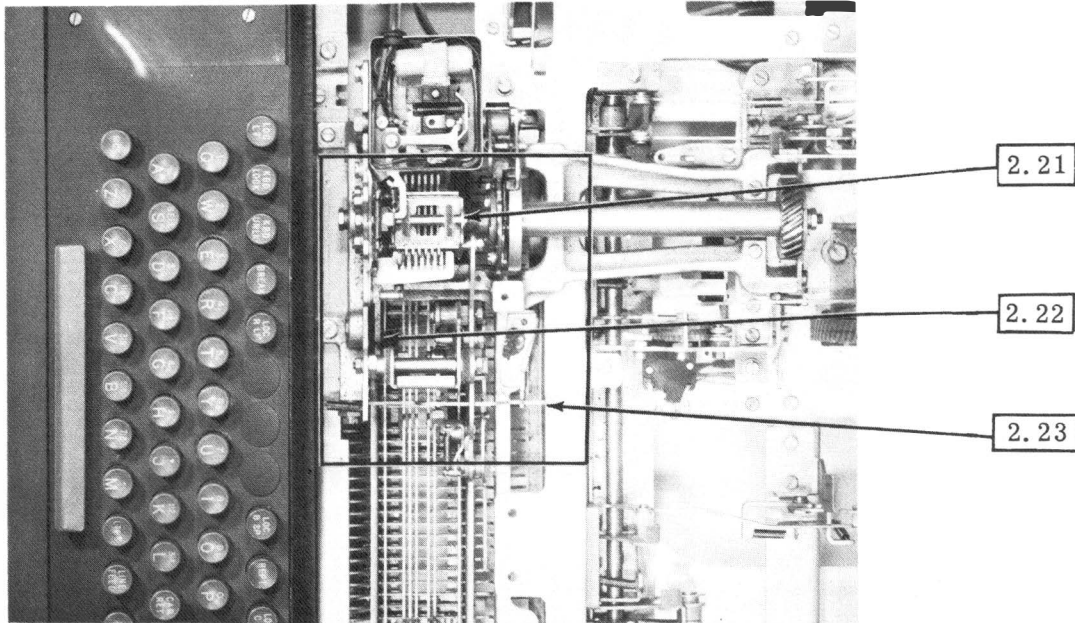

2.21 Locking Bail

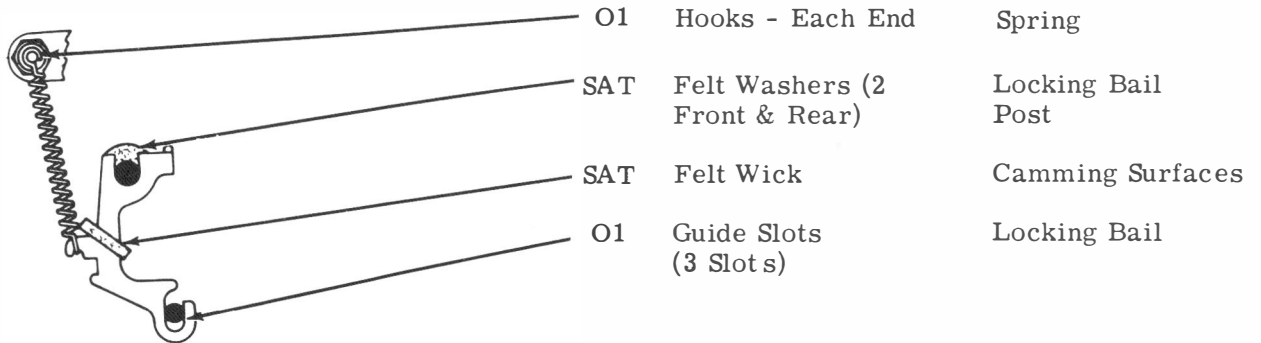

2.22 Codebar Bail

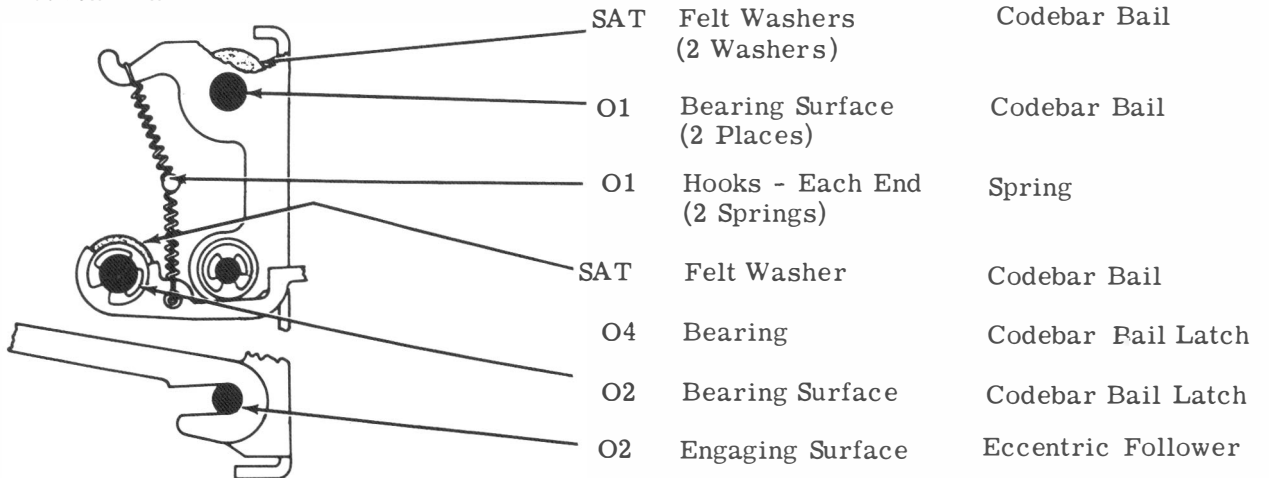

2.23 Universal Bail Latchlever

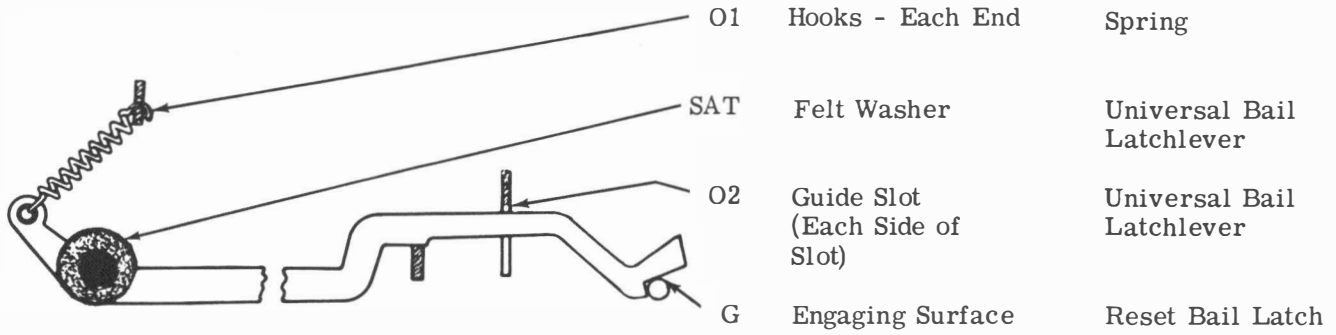

2.24 Keyboard - Left Front View

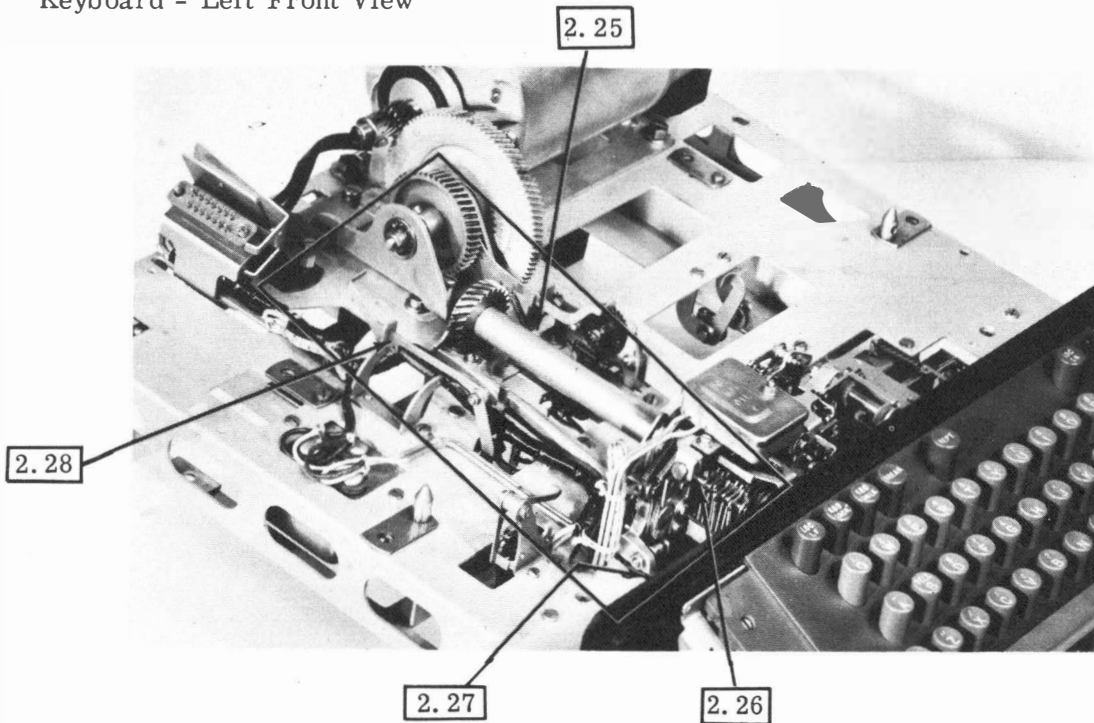

2.25 Electrical Line Break

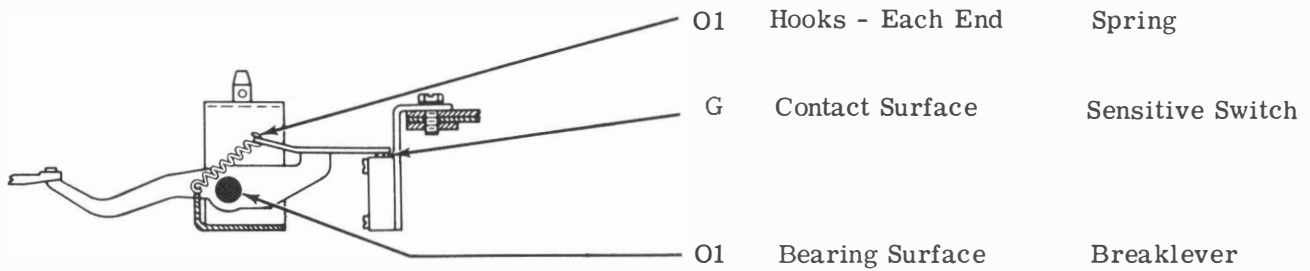

2.26 Codelever Universal Bail

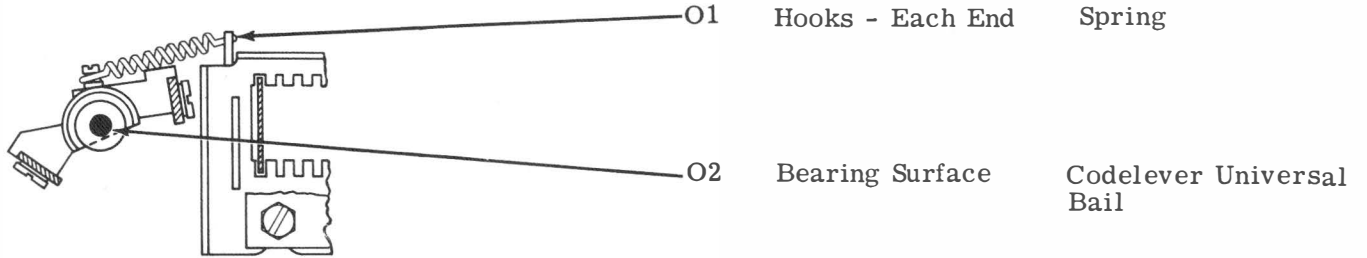

2.27 Lockbar Latch

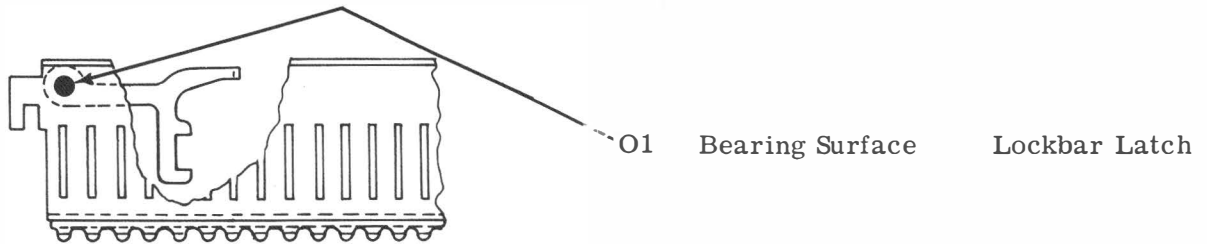

2.28 Local Paper Feed-Out

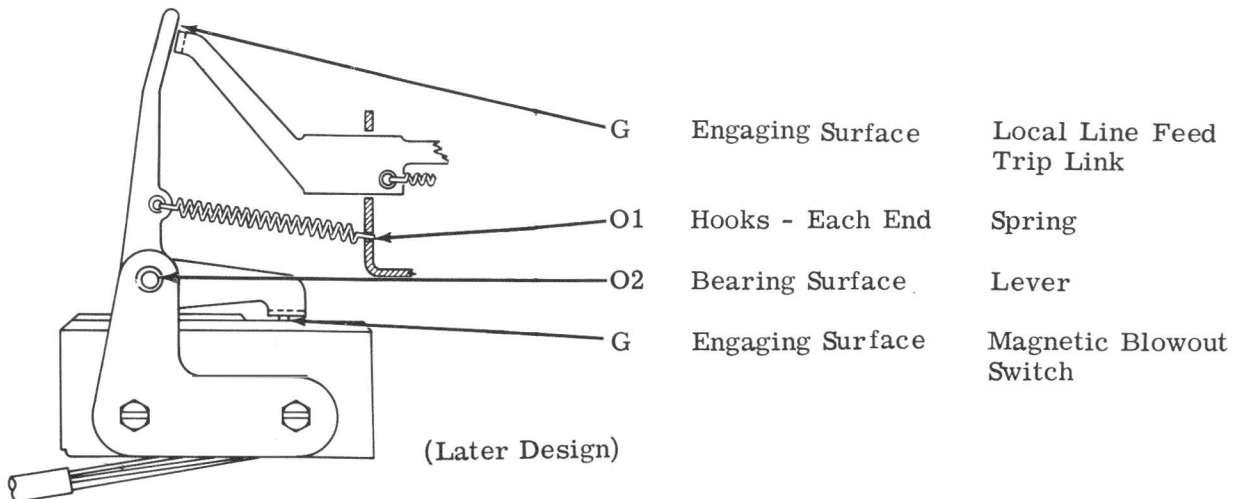

3. VARIABLE FEATURES (KEYBOARD)

3.01 Local Backspace and Line Feed Mechanisms - Left Top View

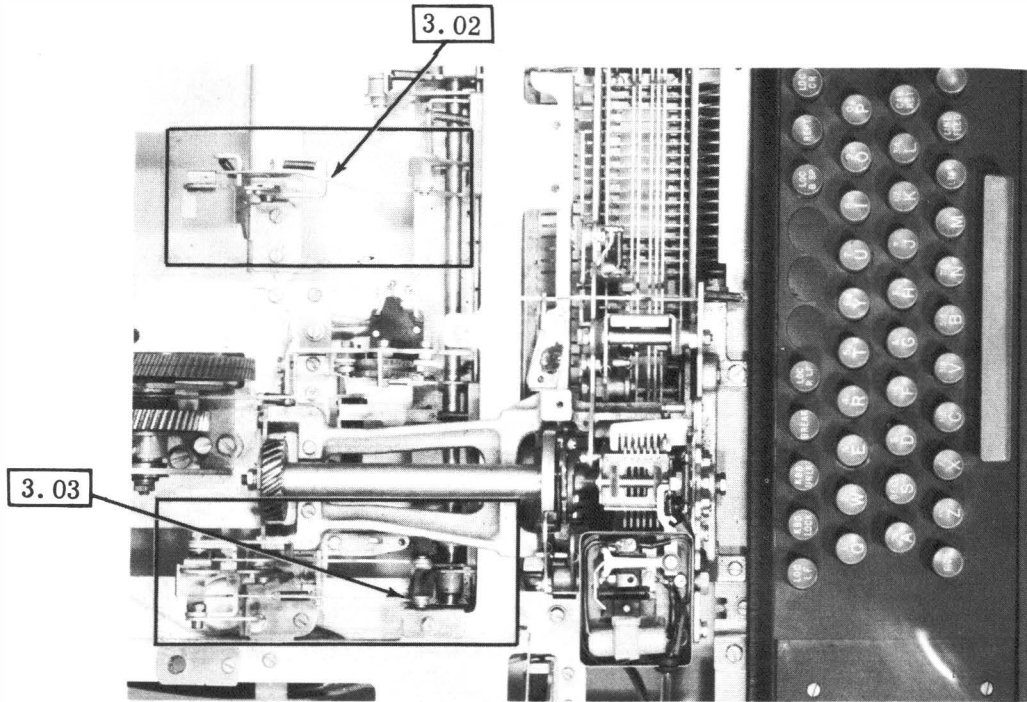

3.02 Local Backspace

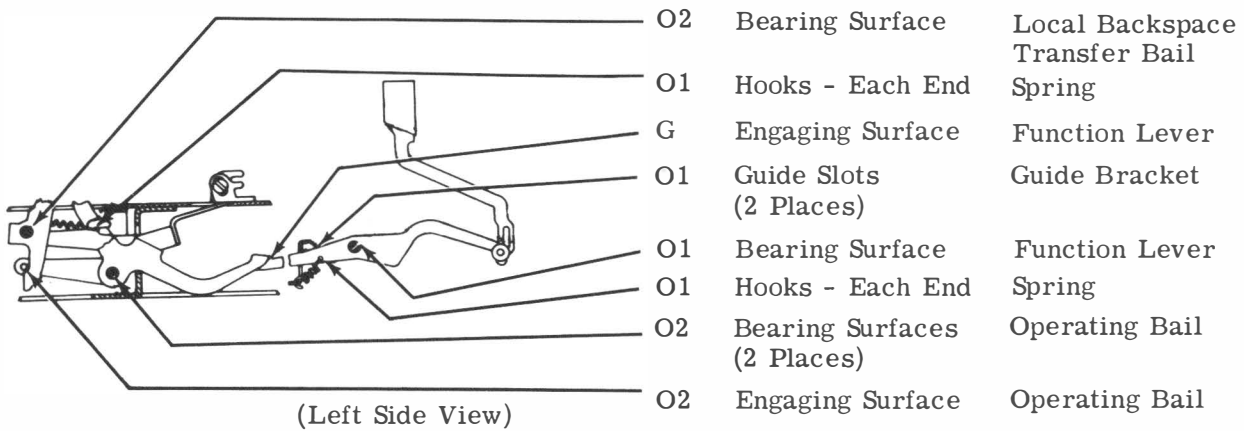

3.03 Local Reverse Line Feed

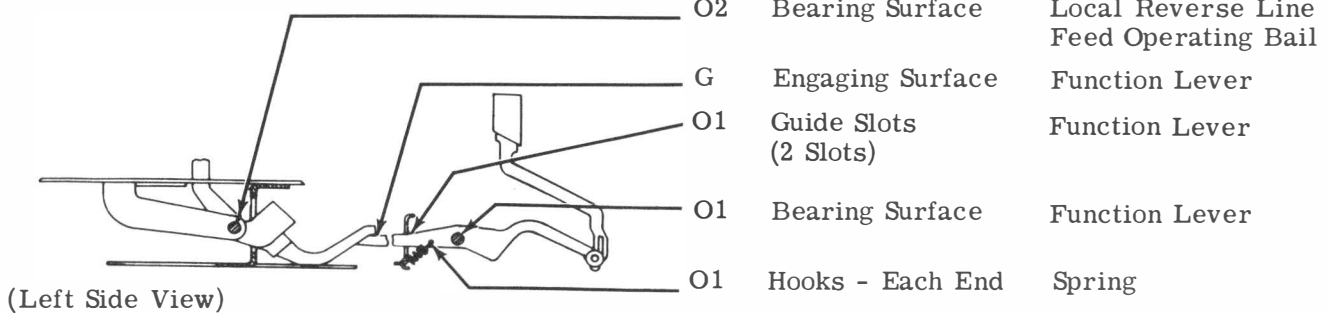

3.04 Answer-Back Mechanism - Top Rear View

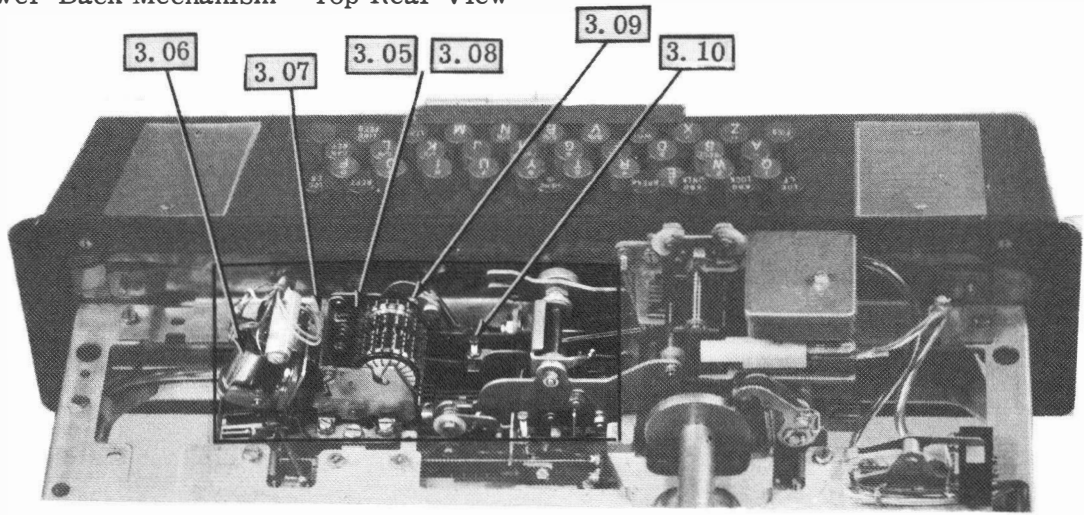

3.05 Answer-Back - Sensing Levers

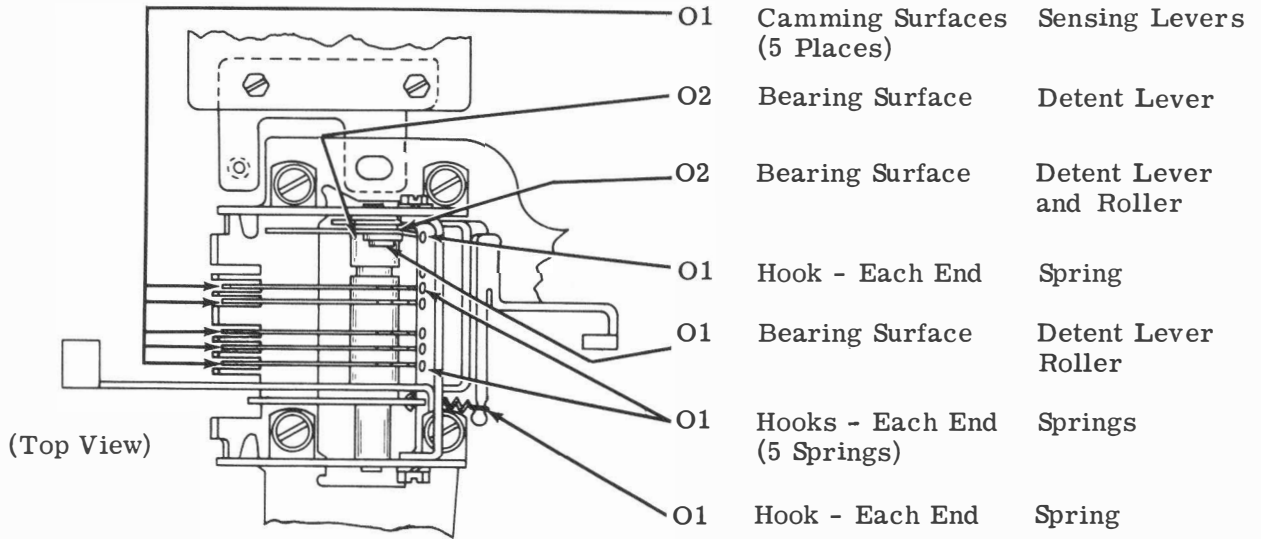

3.06 Answer-Back - Armature

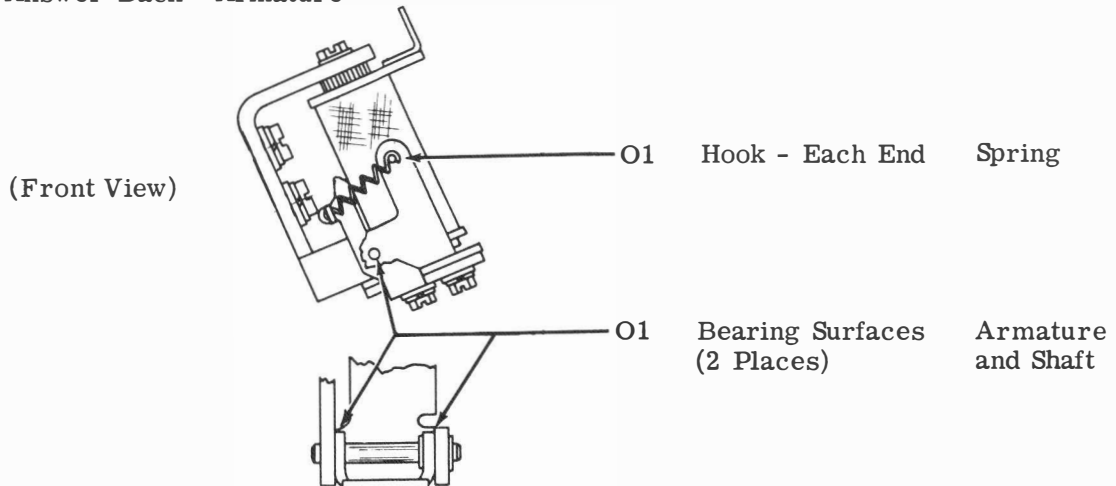

SECTION 573-116-701

3.07 Answer-Back Stop Lever

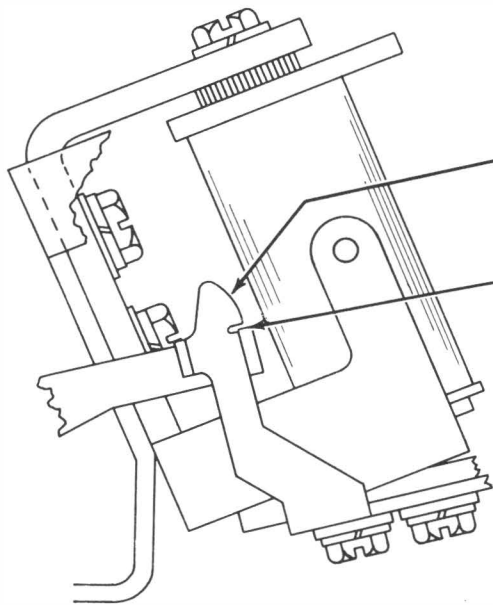

O1 Contacting Surface Latch and Stop Lever

O1 Latching Surface Latch and Stop Lever

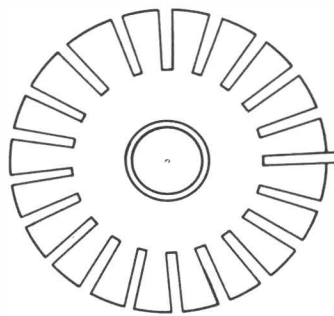

(Front View)

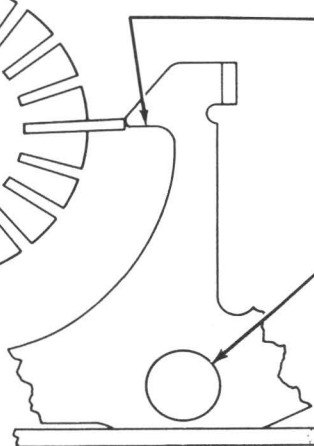

O1 Camming Surface Stop Lever

O2 Bearing Surface (2 Places) Stop Lever and Lever Pivot

3.08 Answer-Back - Codebars and Sensing Levers

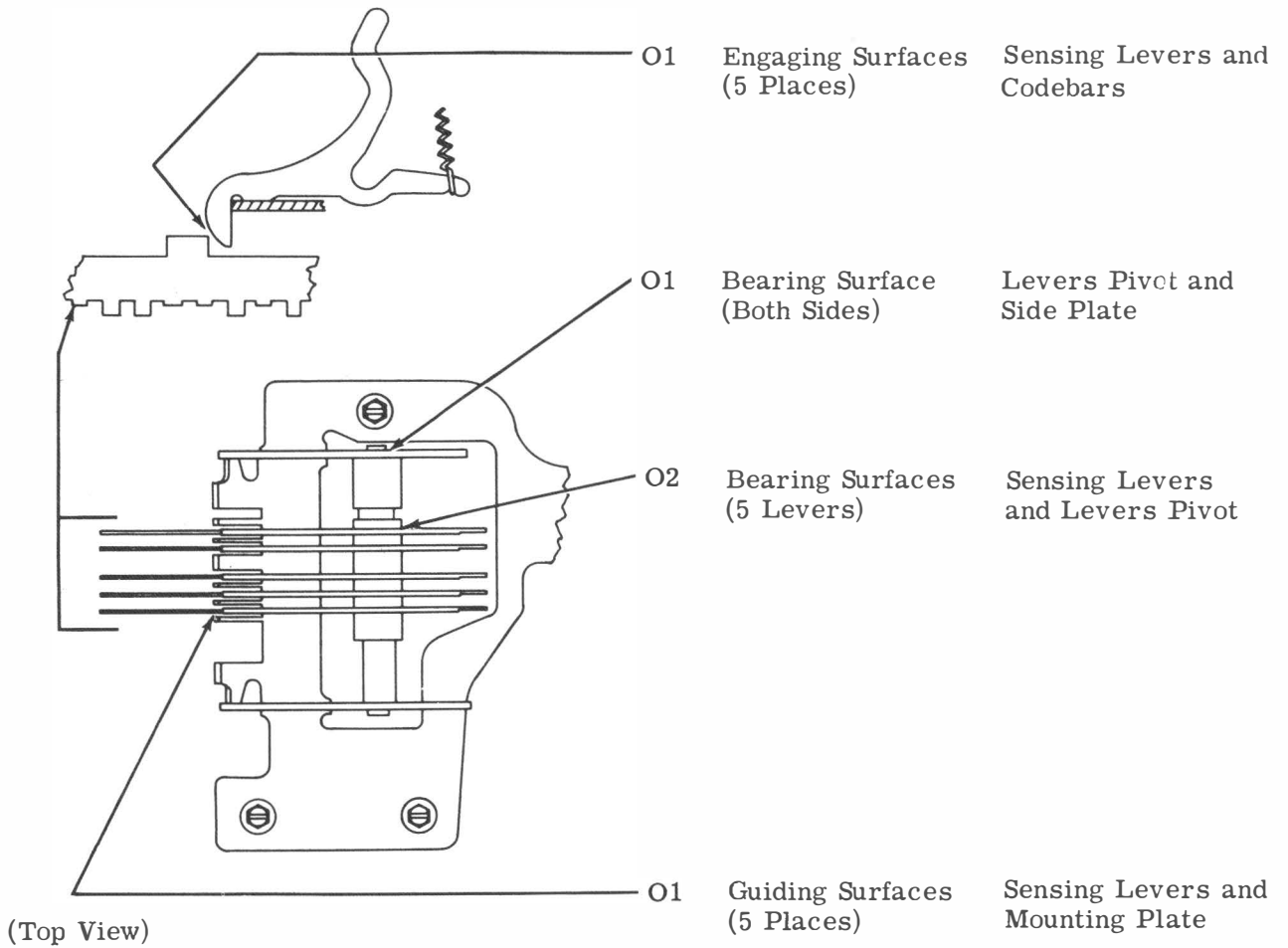

3.09 Answer-Back Driving Mechanism

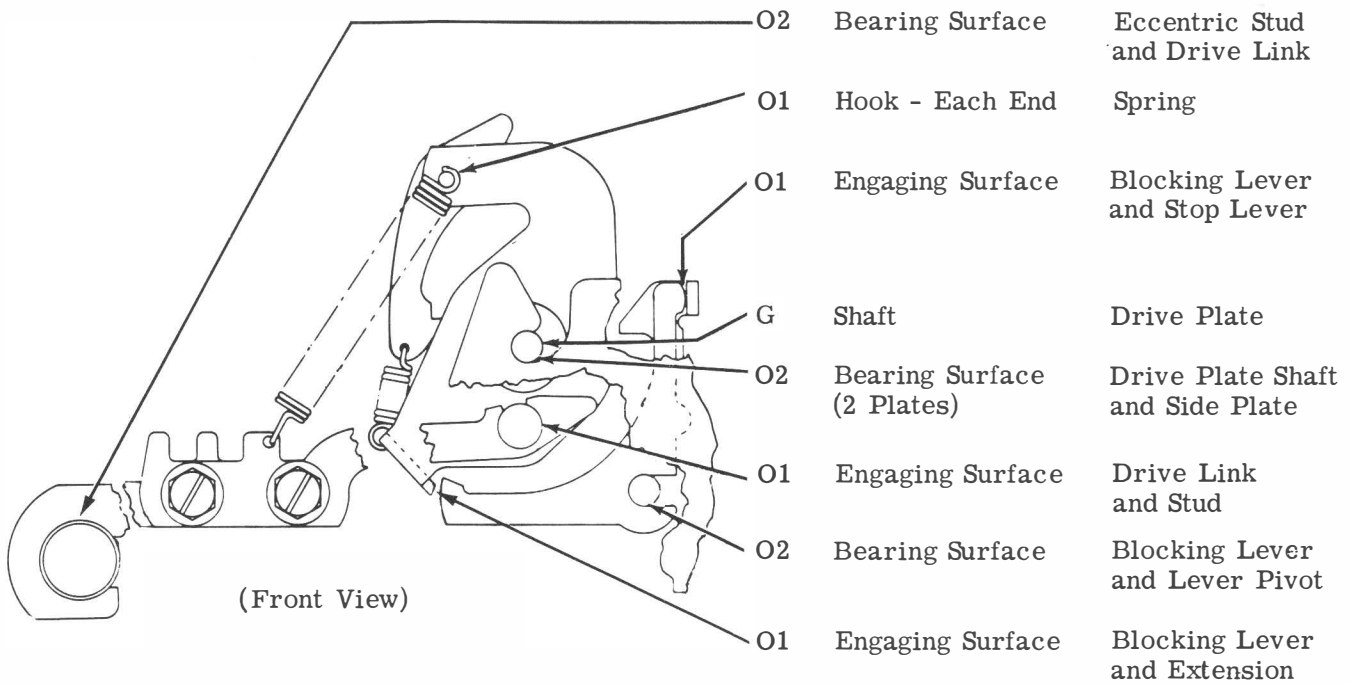

3.10 Answer-Back Stepping Pawl

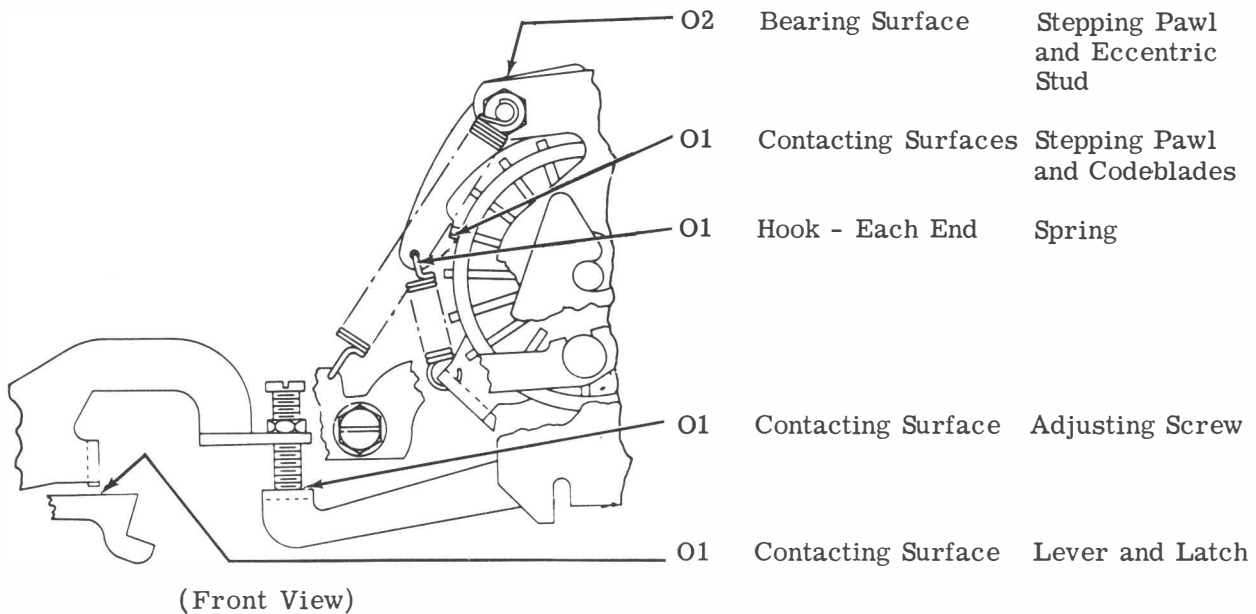



3.11 Answer-Back Keyboard Lock Bail

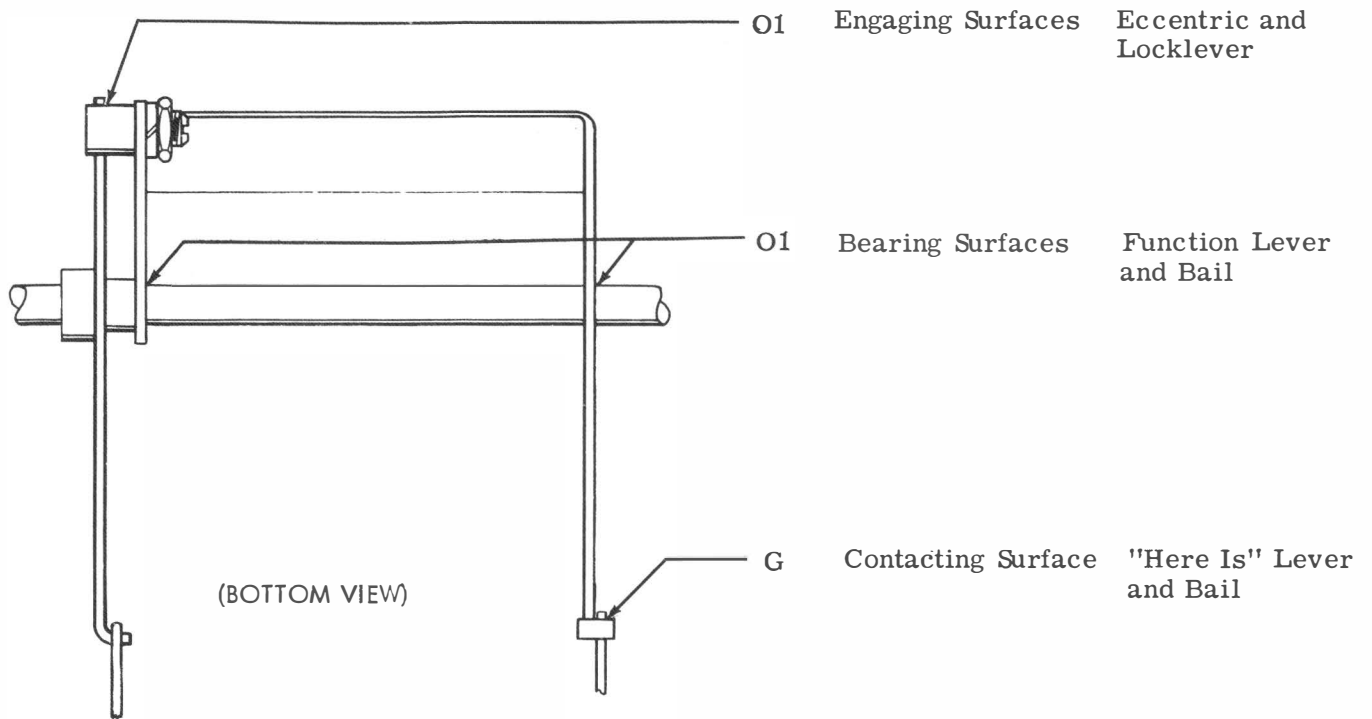

3.12 Variable Speed Drive Mechanism - Rear View

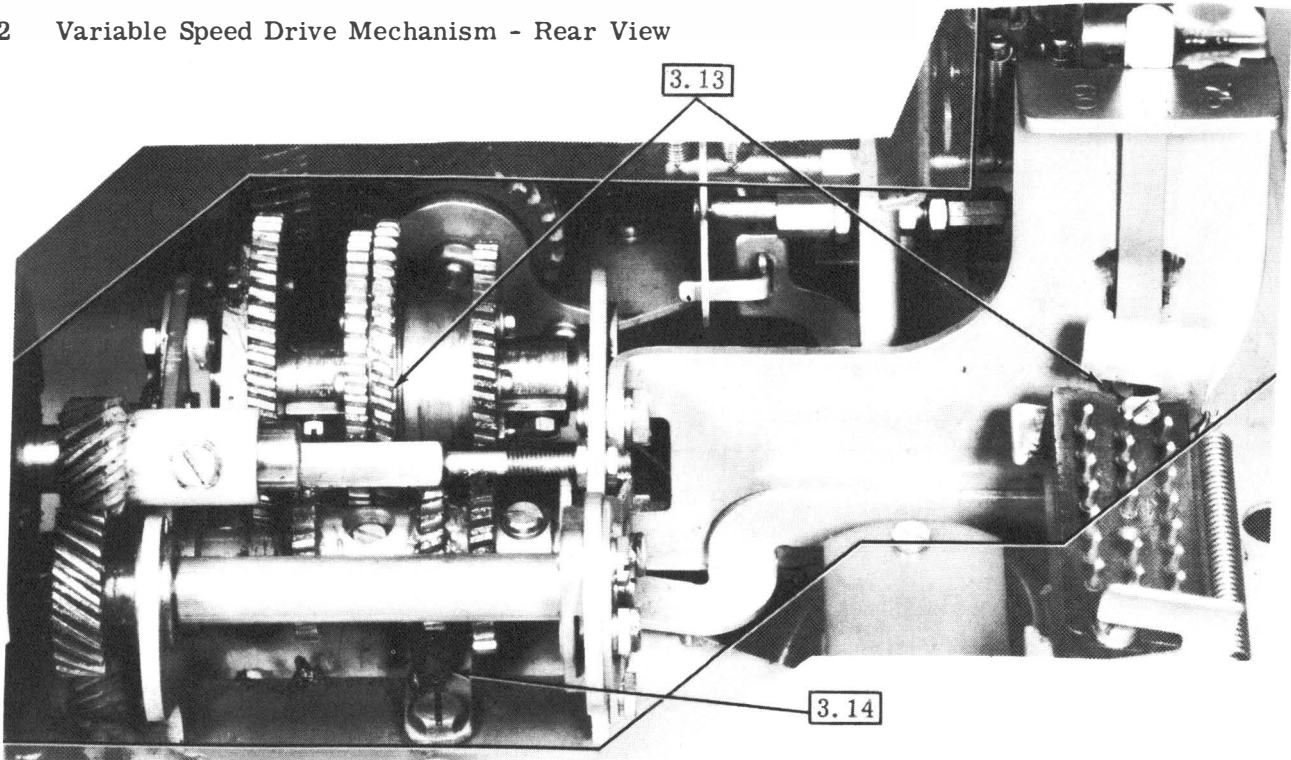

3.13 Variable Speed Drive - Speed Selecting Mechanism

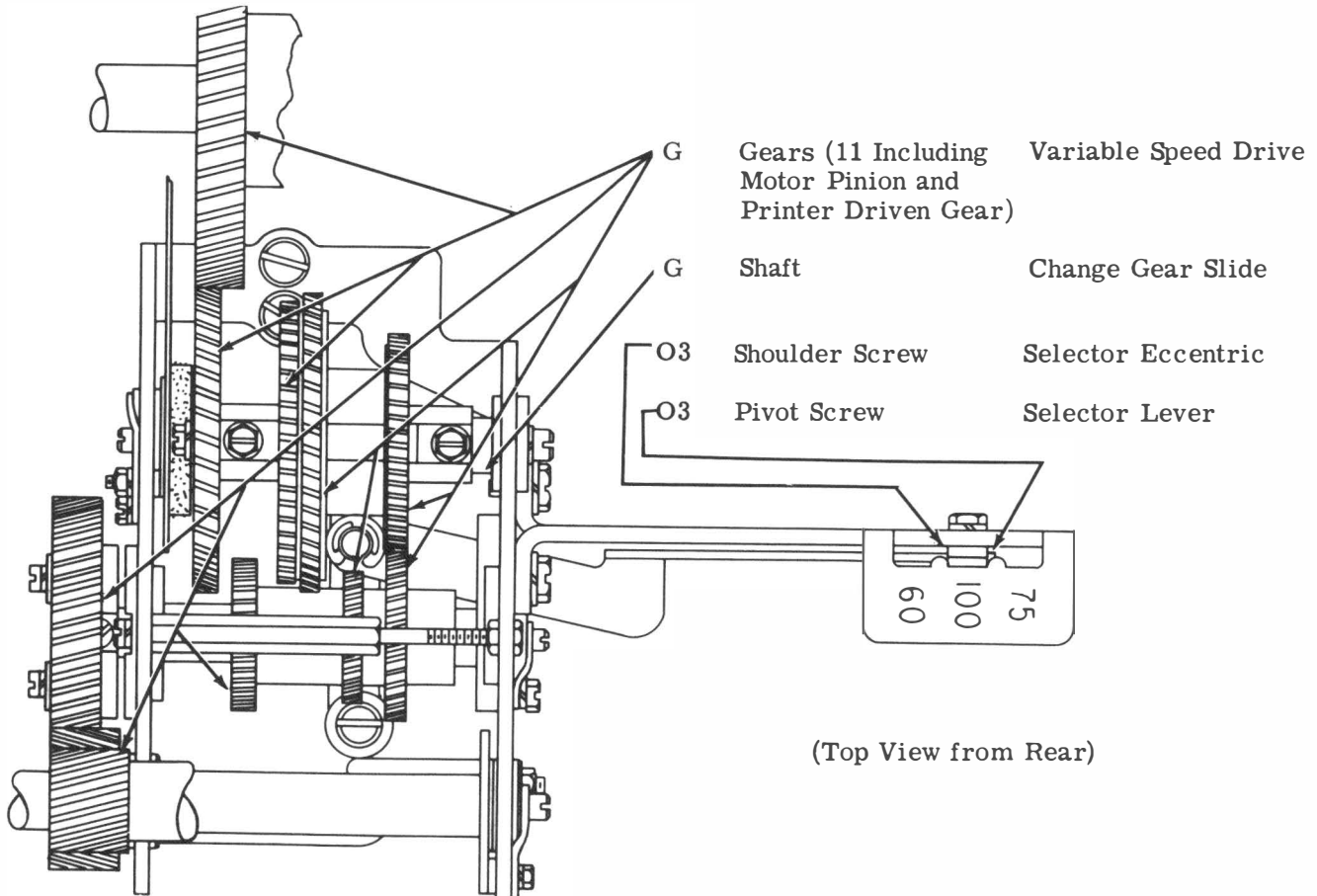

3.14 Variable Speed Drive - Speed Selecting Mechanism (Continued)

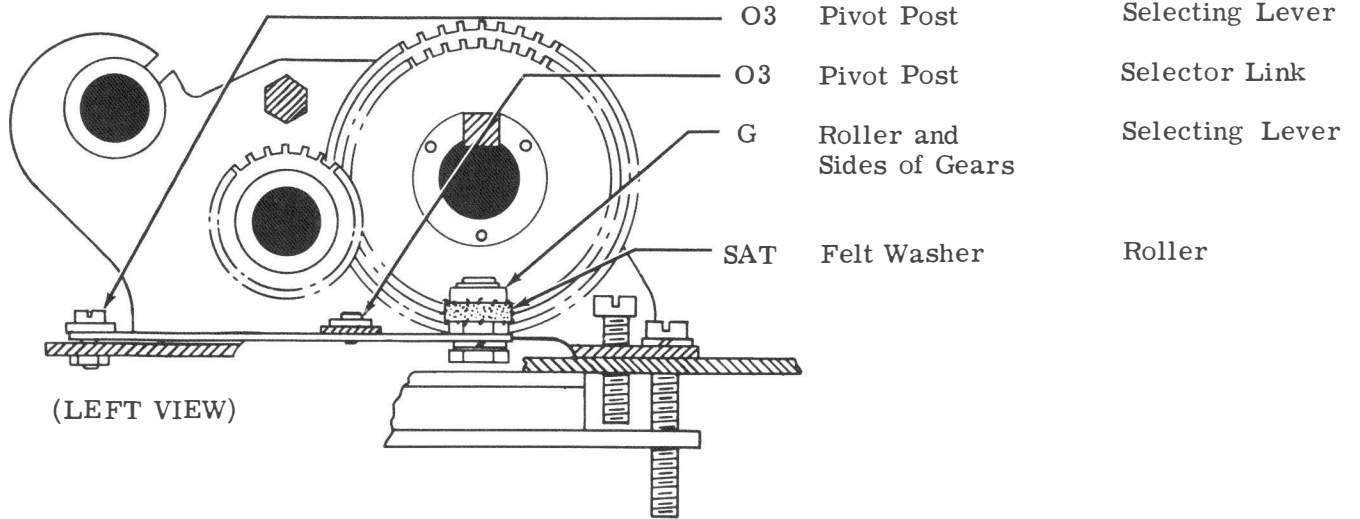

3.15 Blinding (Pulsing) Contact - Left Rear View

3.16 Cam Follower

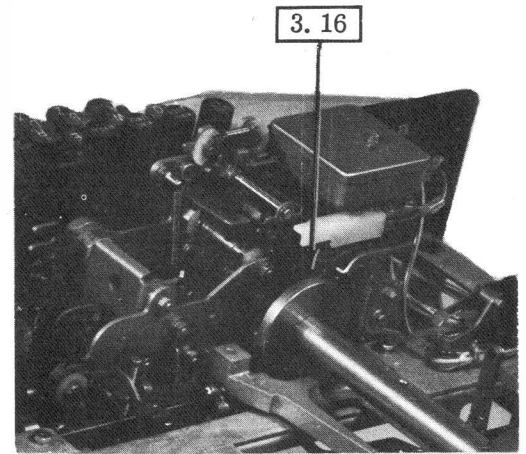
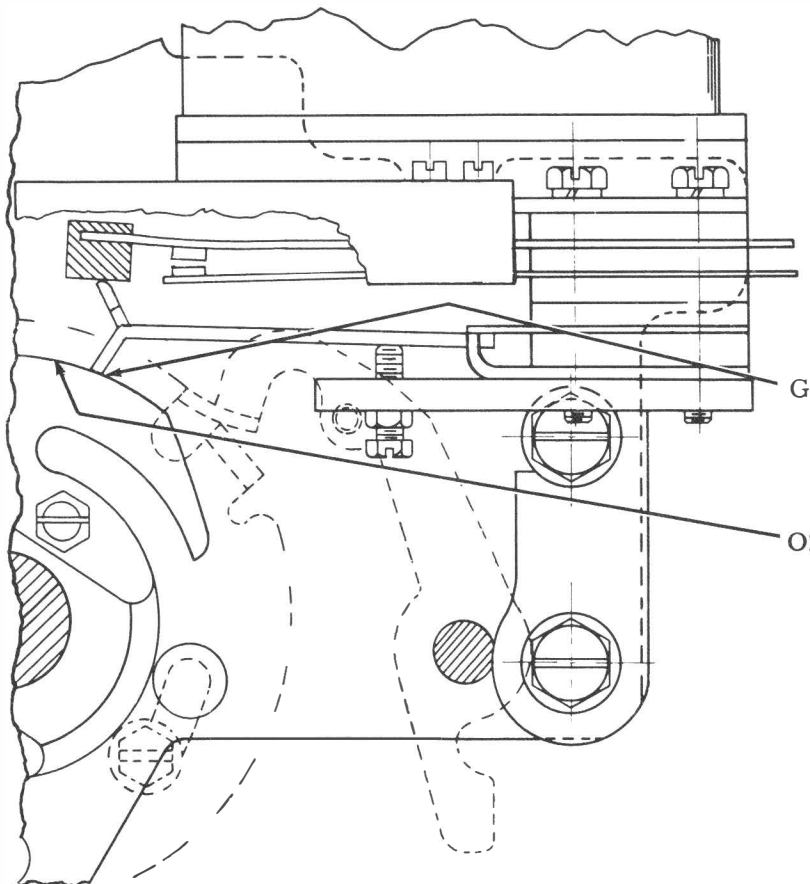

G	Engaging Surface	Cam Follower Extension
O2	Camming Surface	Cam Segment

Note: Avoid getting grease or oil on contact surfaces.

3.17 Remote Control Gear Shift Mechanism - Top View (Tilted Forward)

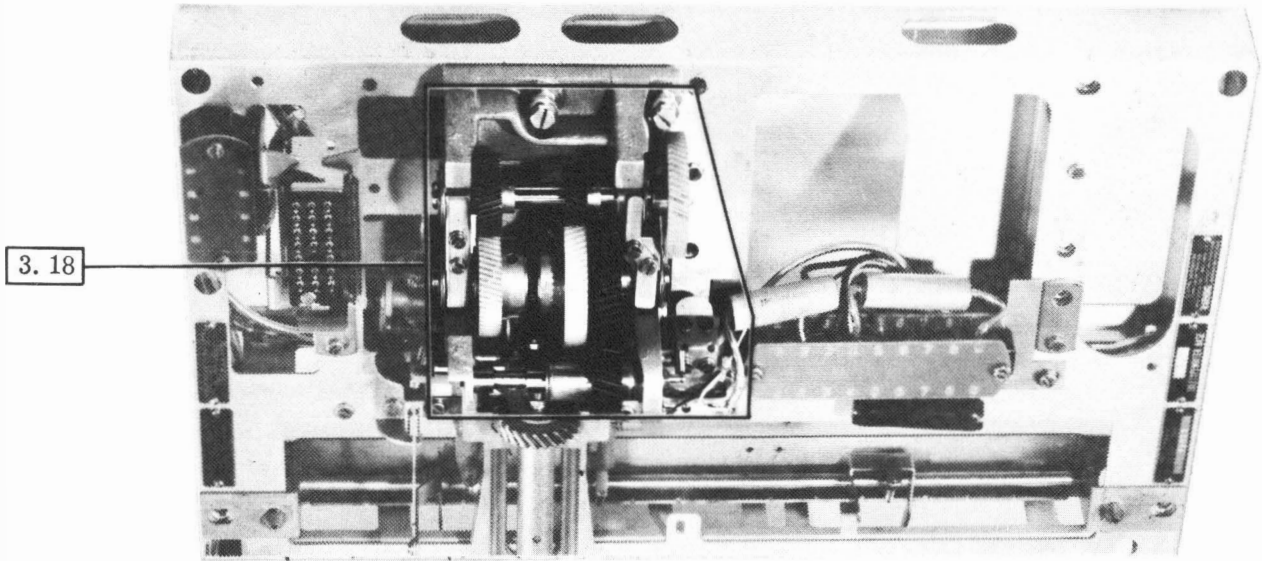

3.18 Remote Control Gear Shift

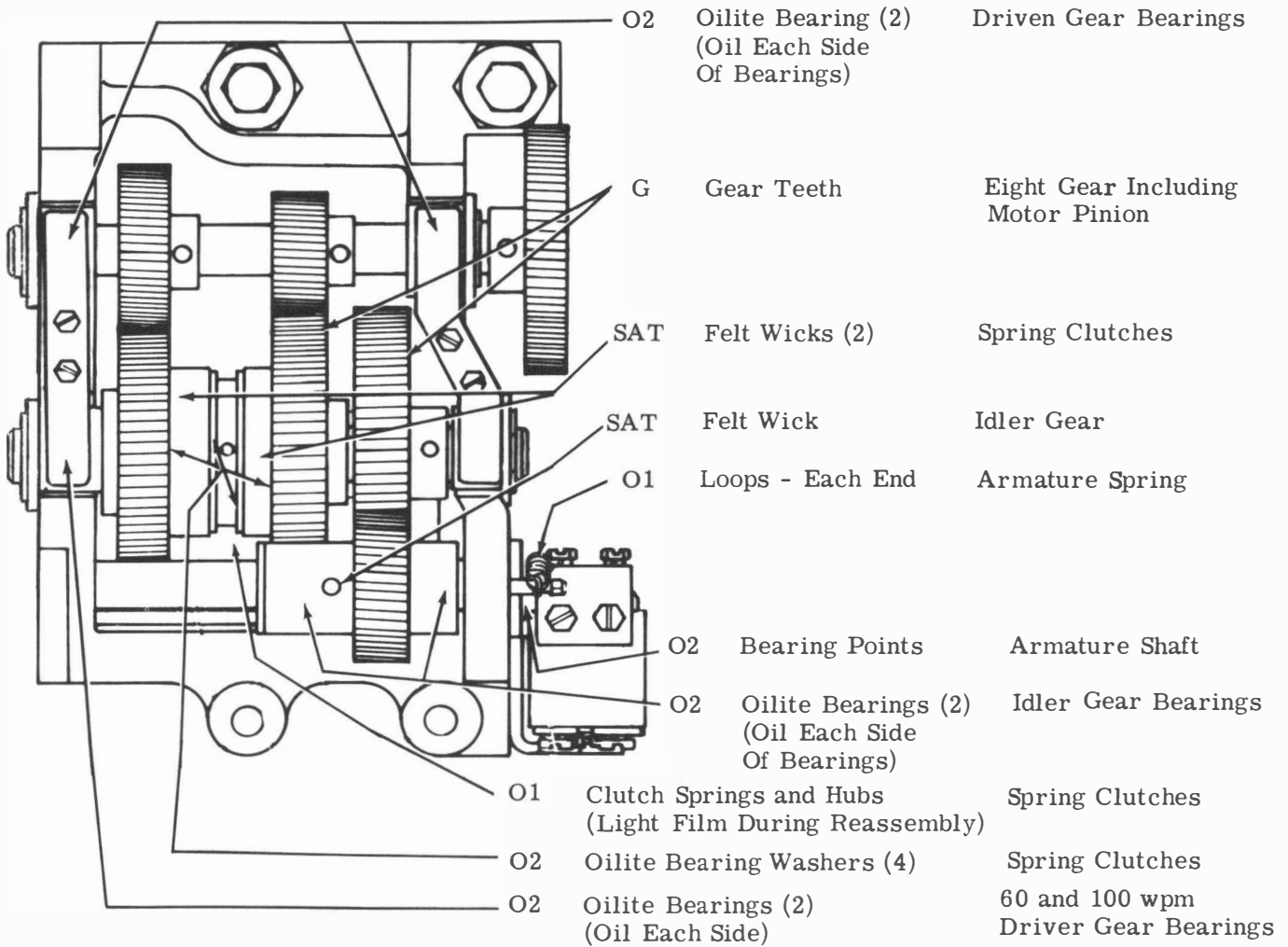

3.19 Form Feed-Out - Left Rear View

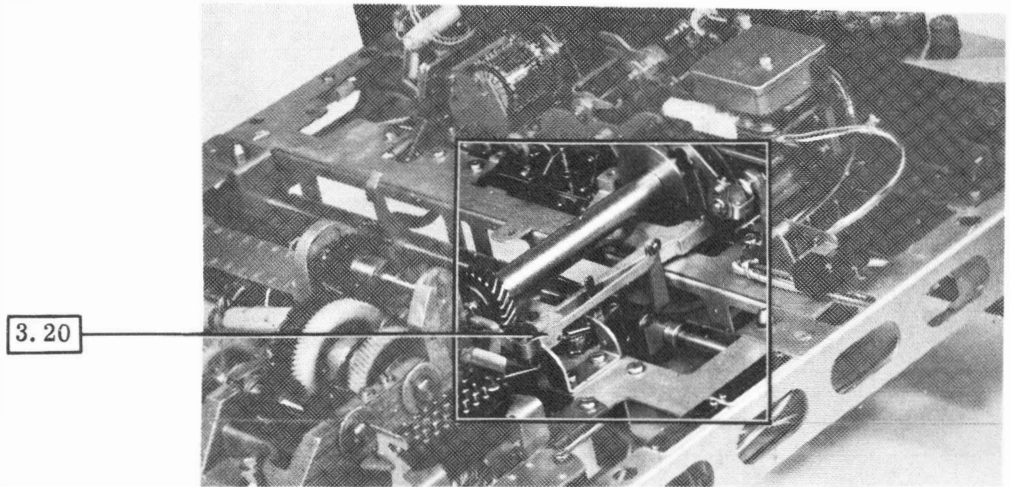

3.20 Form Feed-Out

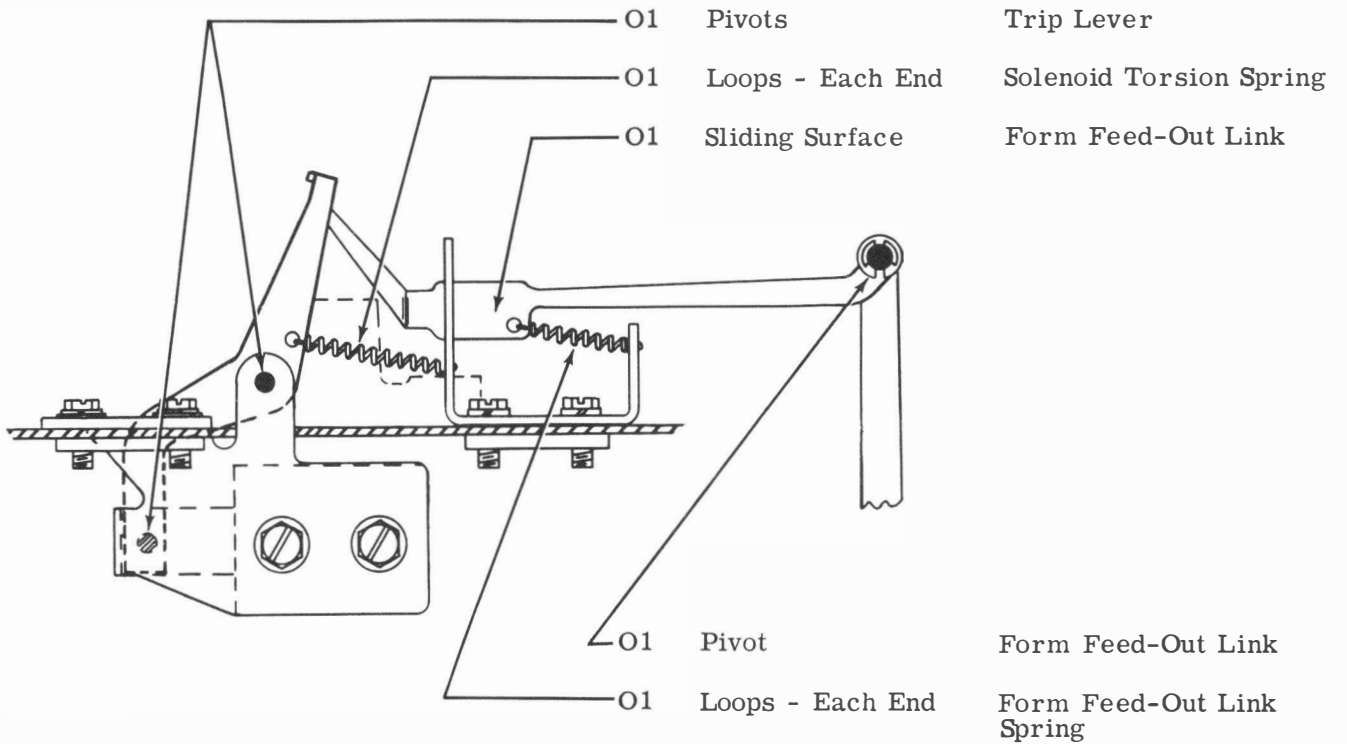

3. 21 Lockbar Contact

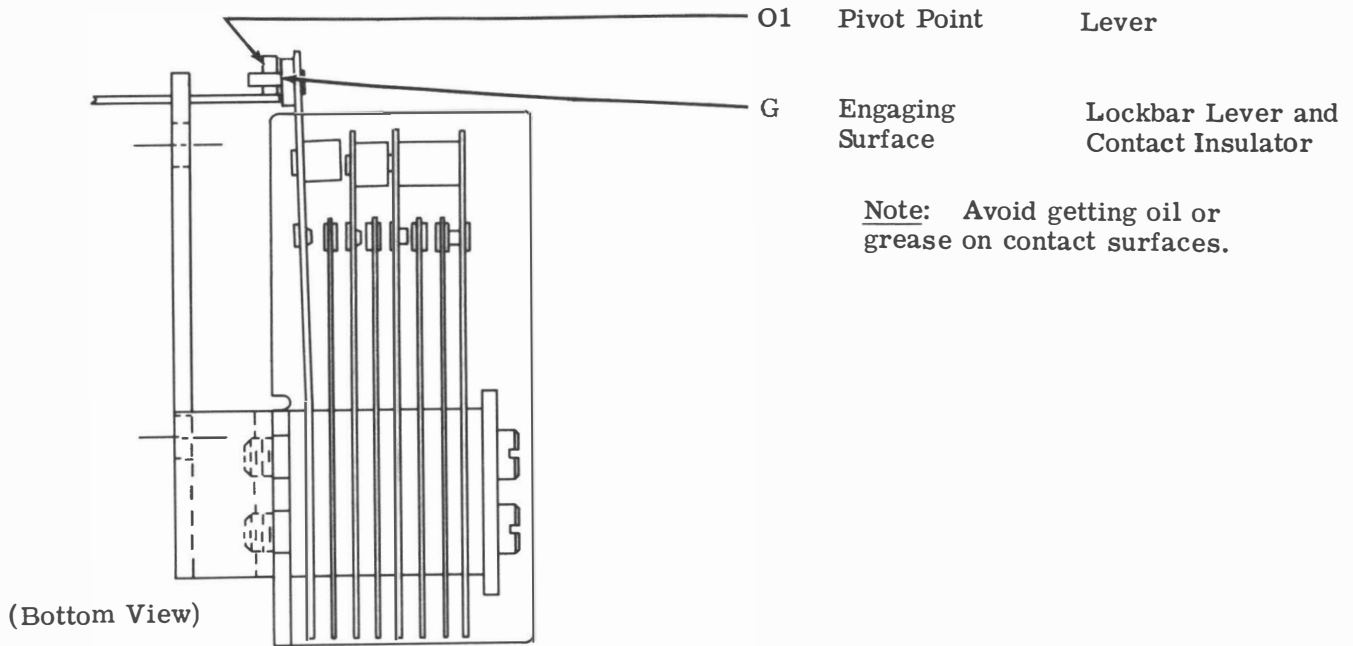

Note: Avoid getting oil or grease on contact surfaces.

3. 22 Repeat on Space Mechanism

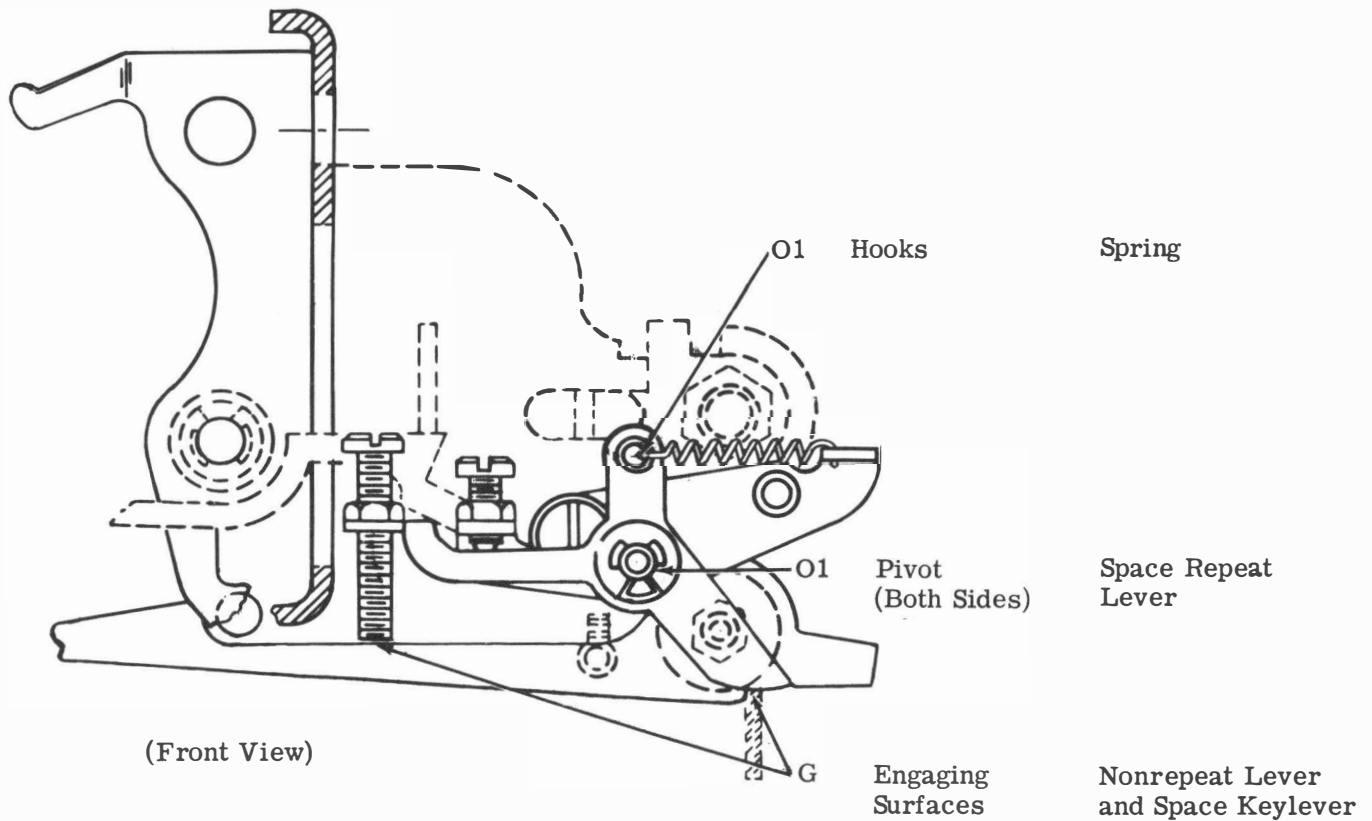

3.23 Keyboard - Top View

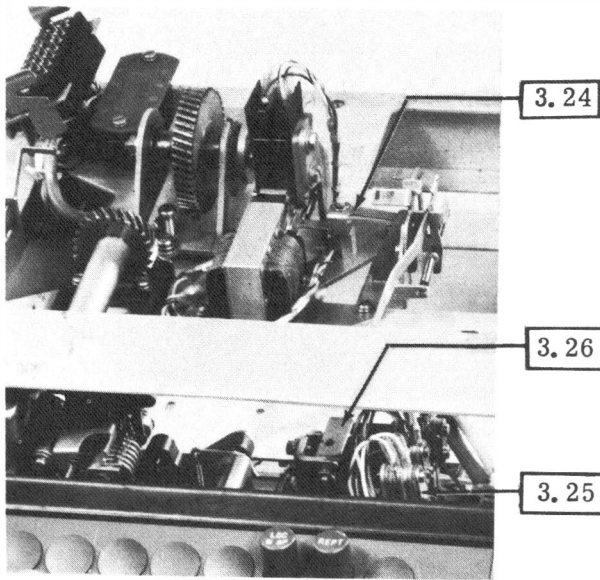

3.24 Solenoid Bail

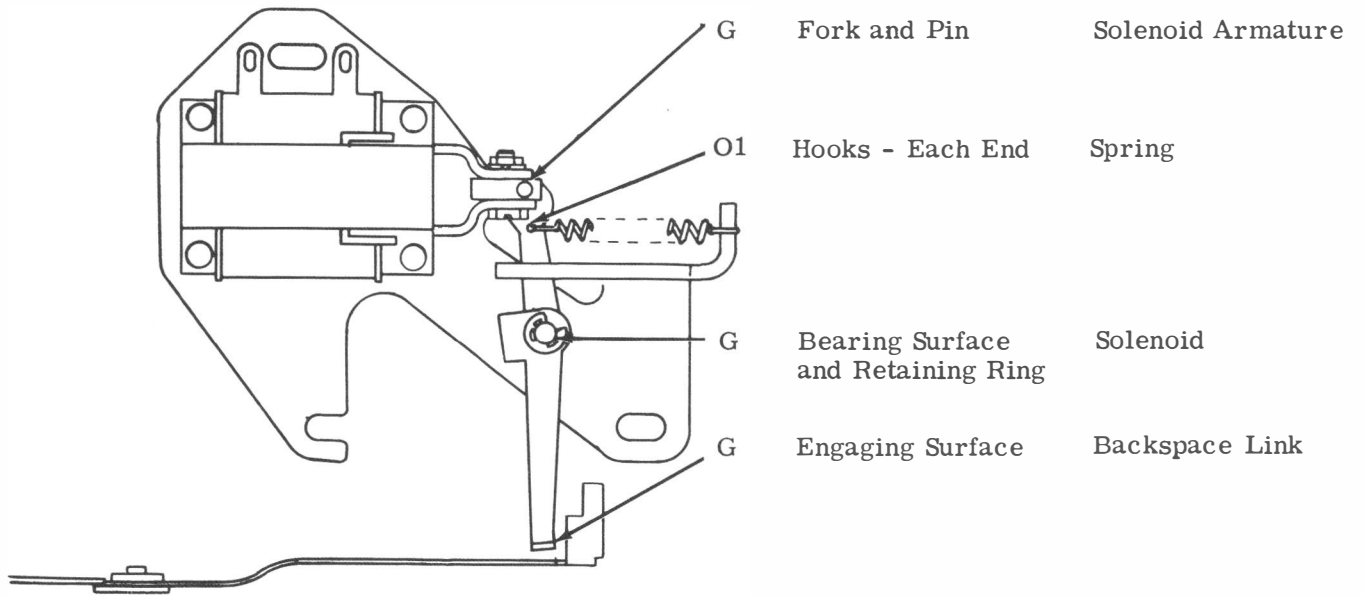

3.25 Off-Line Contacts

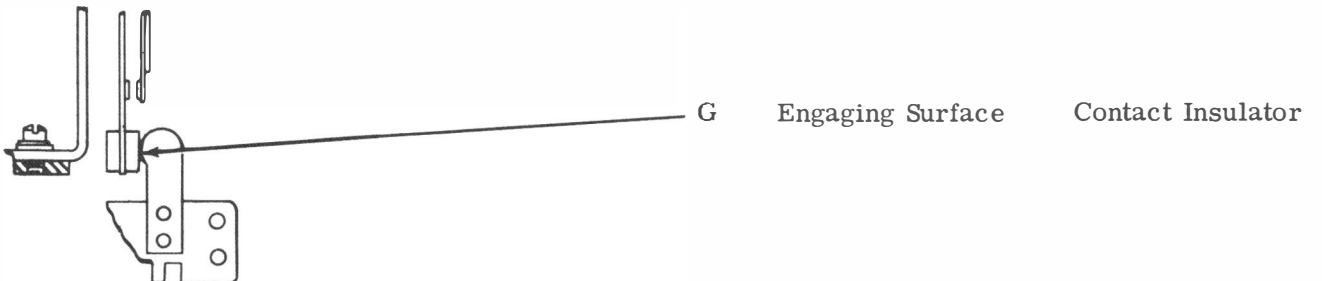

3.26 Switch Operating Lever

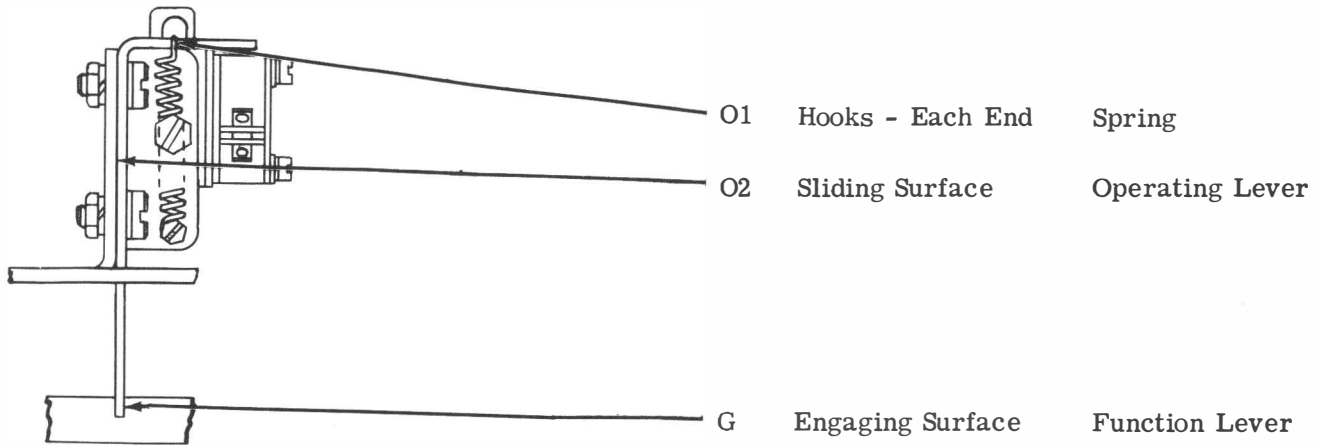

3.27 Universal Keyboard Switch (Not Shown on a Locator Photograph)

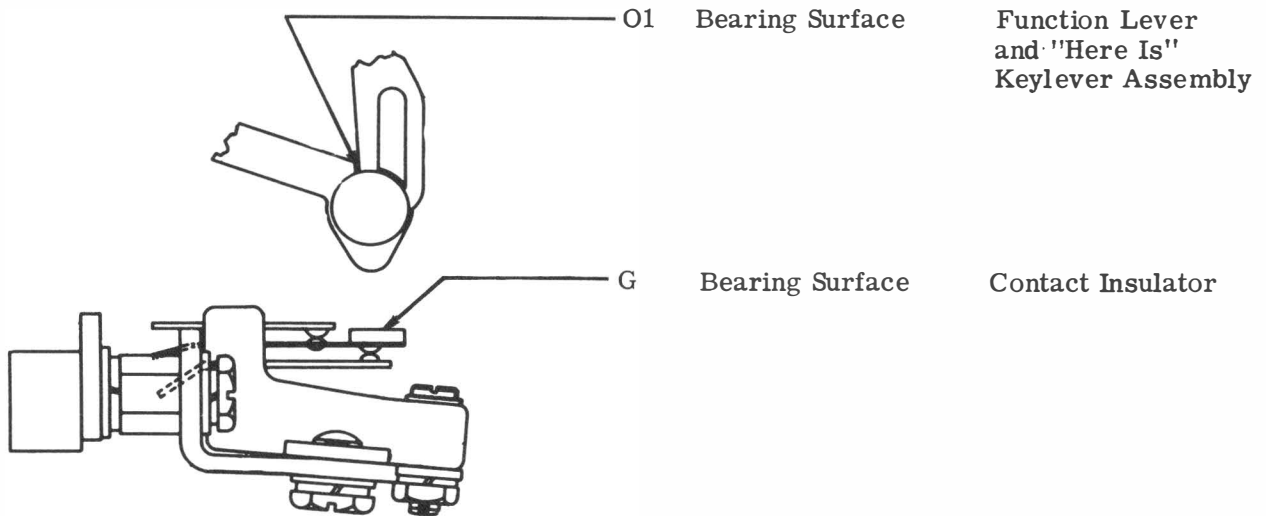



4. EARLIER DESIGN KEYBOARD

4.01 Keyboard - Bottom View

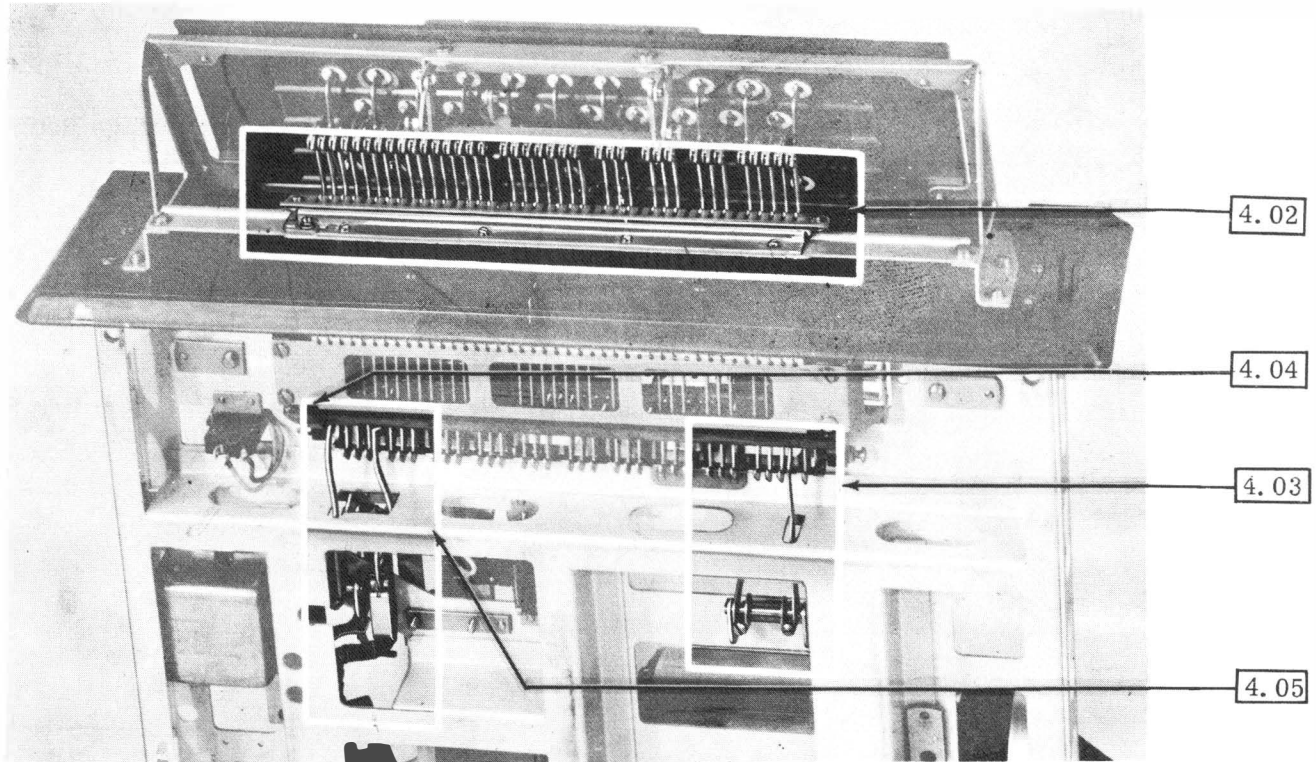

4.02 Codelever

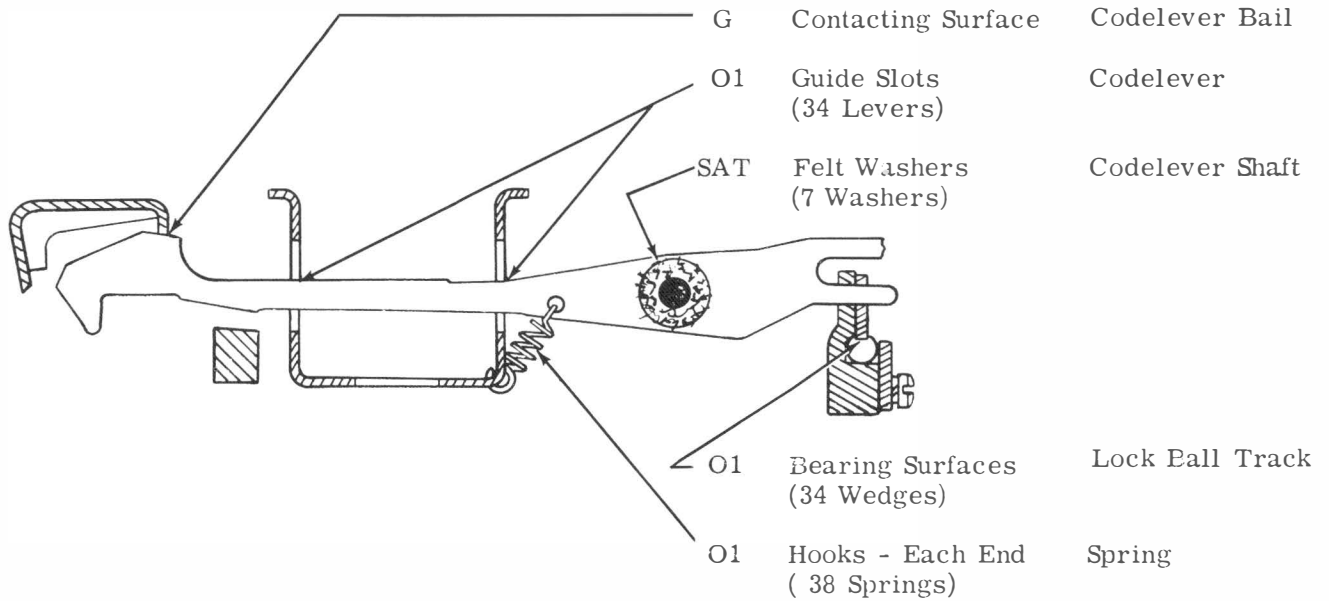

4.03 Local Carriage Return

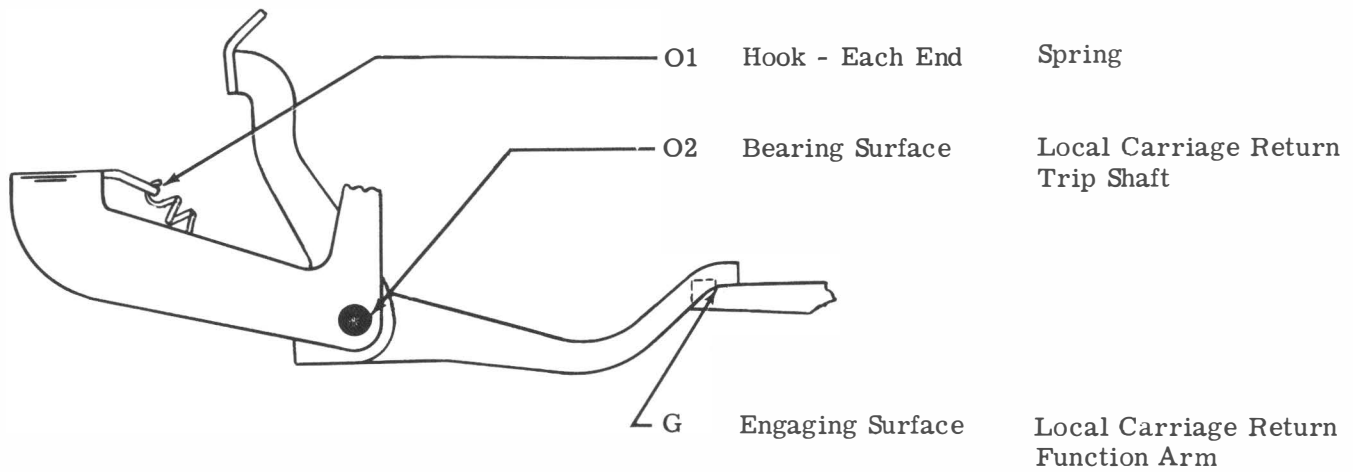

4.04 Local Line Feed

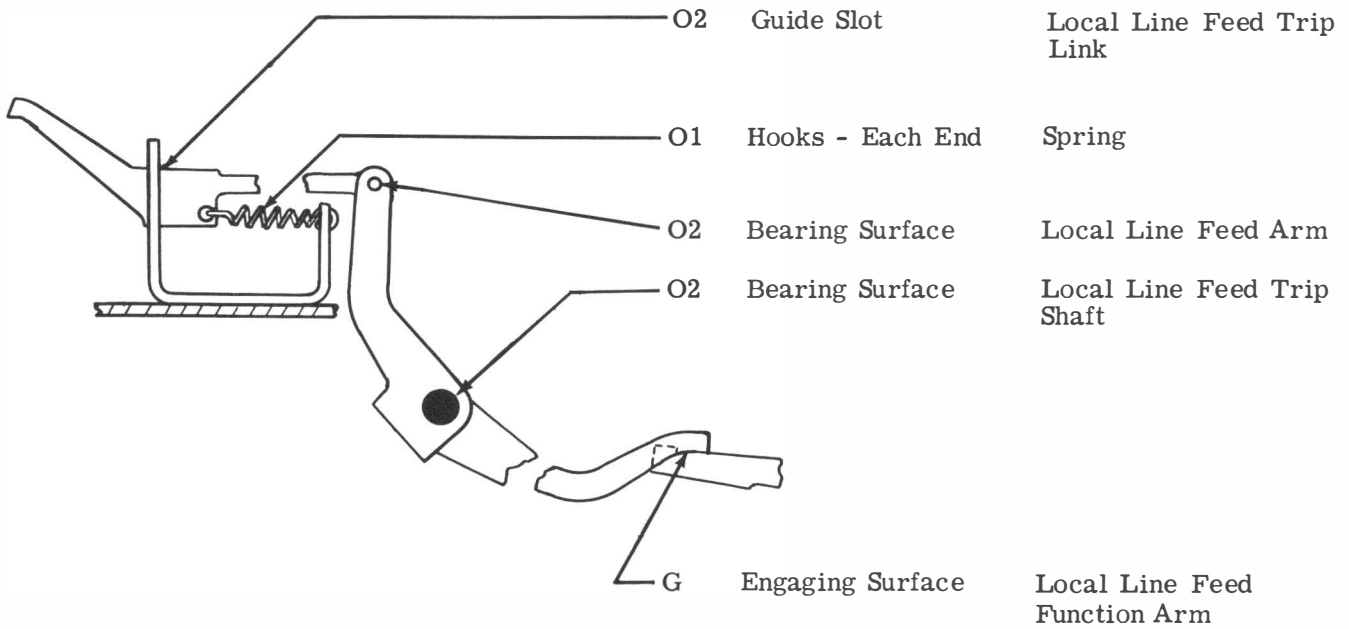

4.05 Keyboard Lock

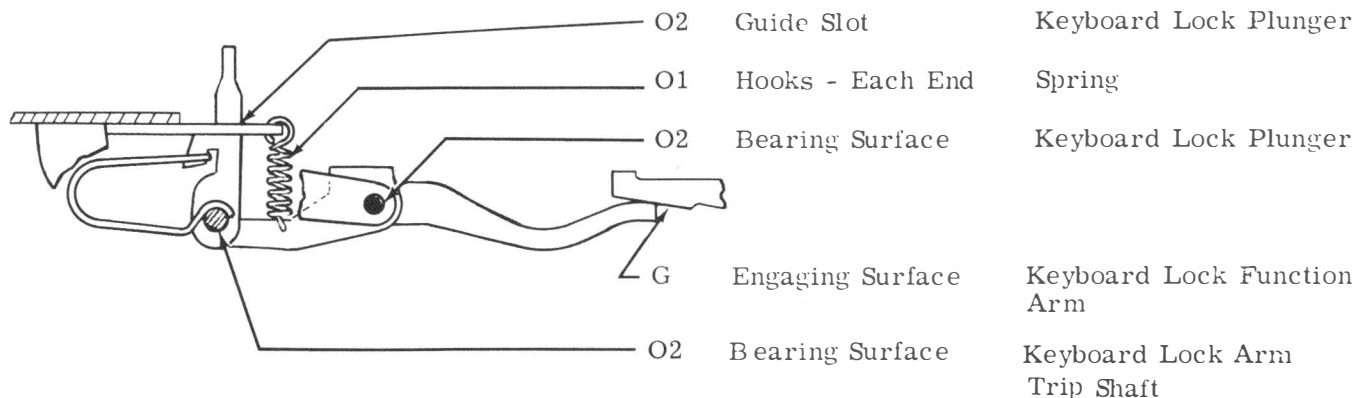

4.06 Codebar Mechanism - Top Front View

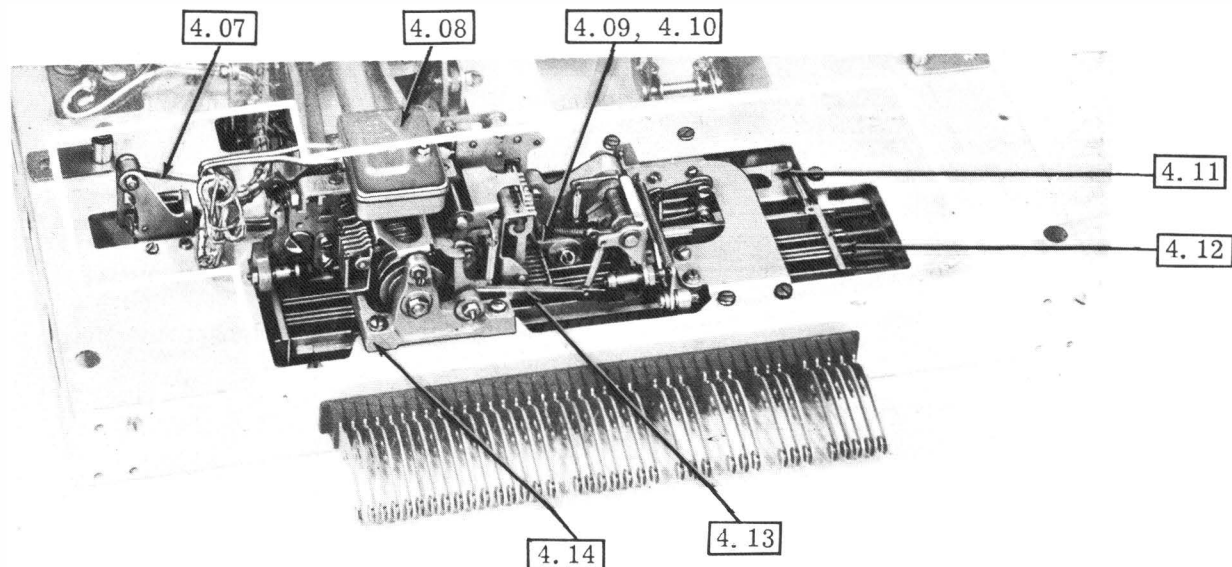

4.07 Margin Indicator

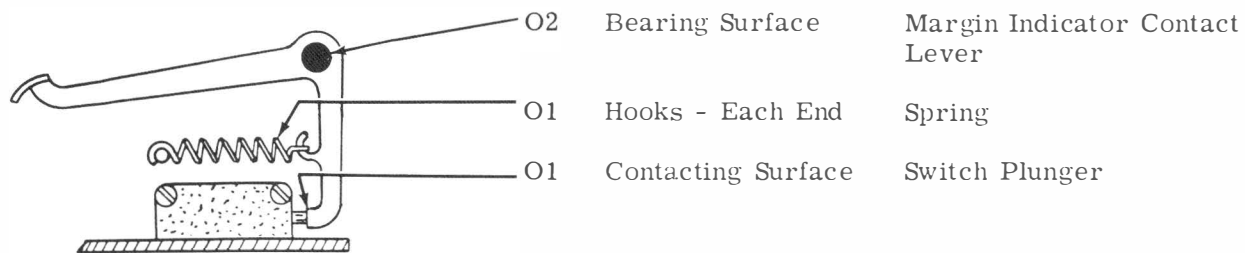

4.08 Contact Box

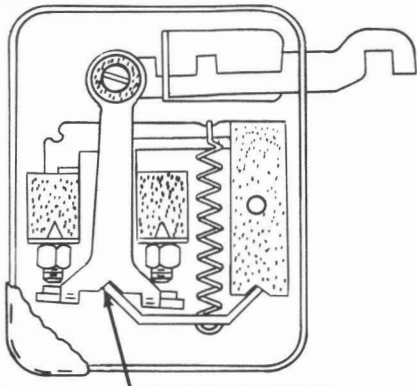

Disassembly: Remove nut and lockwasher securing contact box cover and remove cover.

G Engaging Surface Contact Toggle

4.09 Codebar

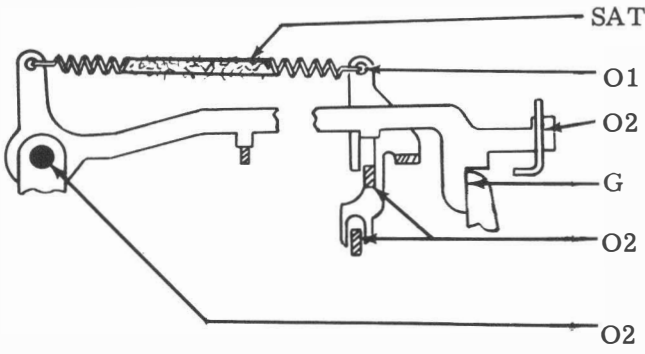

SAT Felt Wick Spring Wick  
 O1 Hooks - Each End Spring  
 O2 Guiding Surface Codelever Bail Latchlever  
 G Engaging Surface Codelever Bail  
 O2 Guiding Surfaces (2 Places) Nonrepeat Bell Cranks  
 O2 Bearing Codelever Bail Latchlever

4.10 Codebar (Continued)

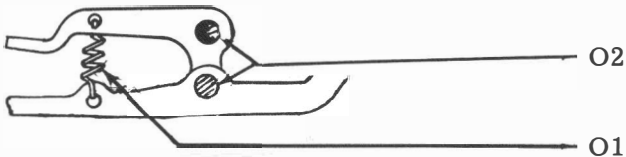

O2 Bearing Surfaces (2 Places) Nonrepeat Bell Crank  
 O1 Hooks - Each End Spring

4.11 Codelever Bail

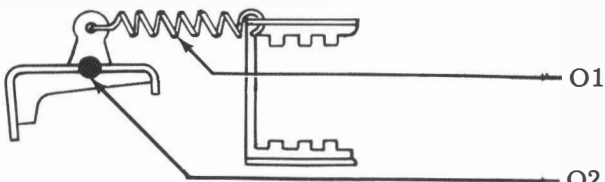

O1 Hooks - Each End Spring  
 O2 Bearing Surfaces (Right and Left) Codelever Bail

4.12 Codebar (Continued)

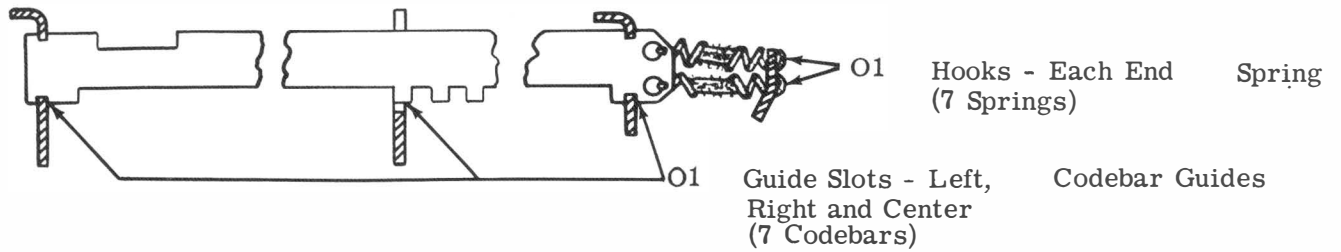

4.13 Codebar Bail and Eccentric Follower

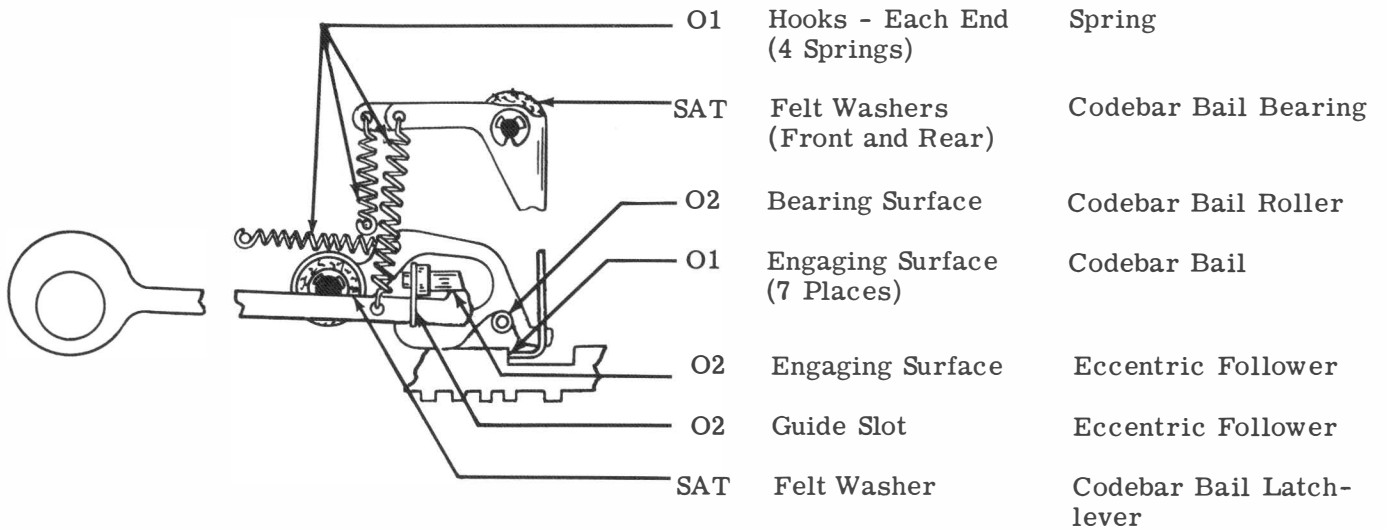

4.14 Keyboard Selector

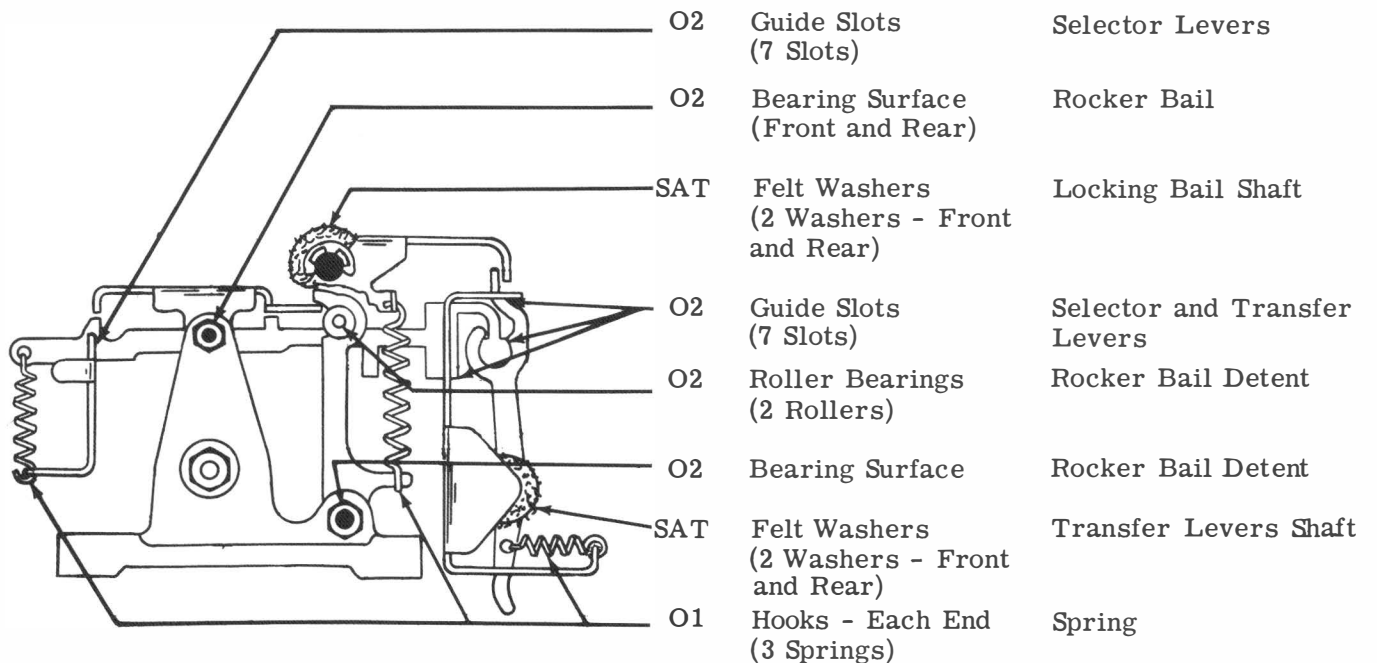

4.15 Intermediate Gear - Front View

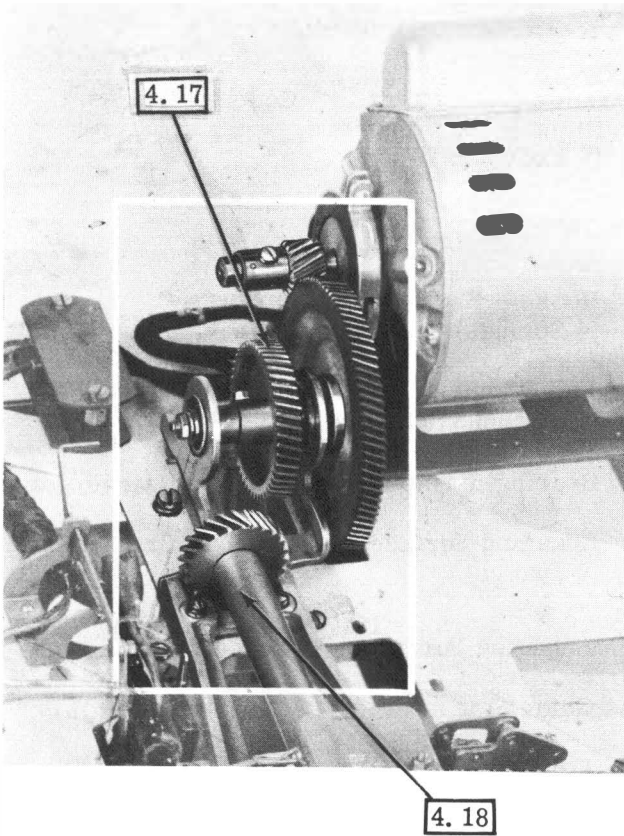

4.16 Signal Generator Mechanism - Left Rear View

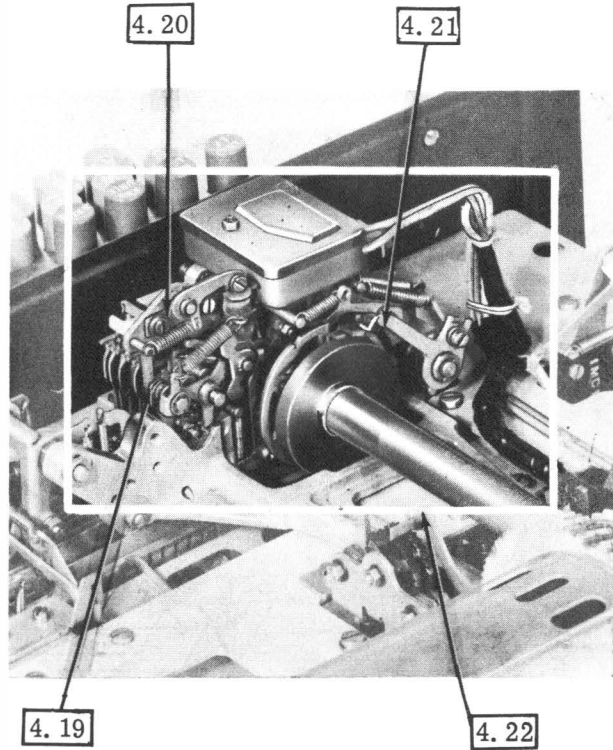

4.17 Intermediate Gears

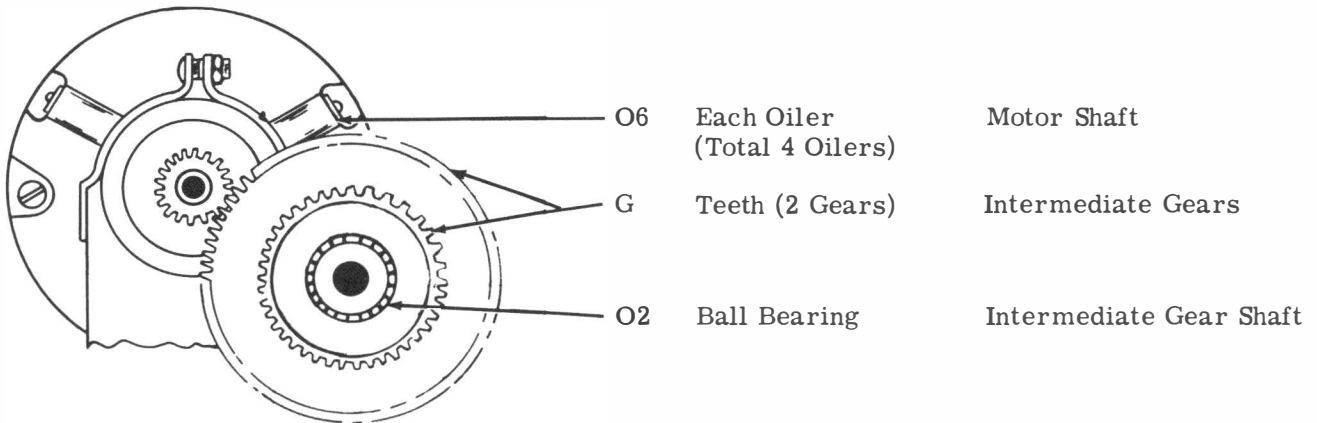

4 18 Signal Generator Shaft

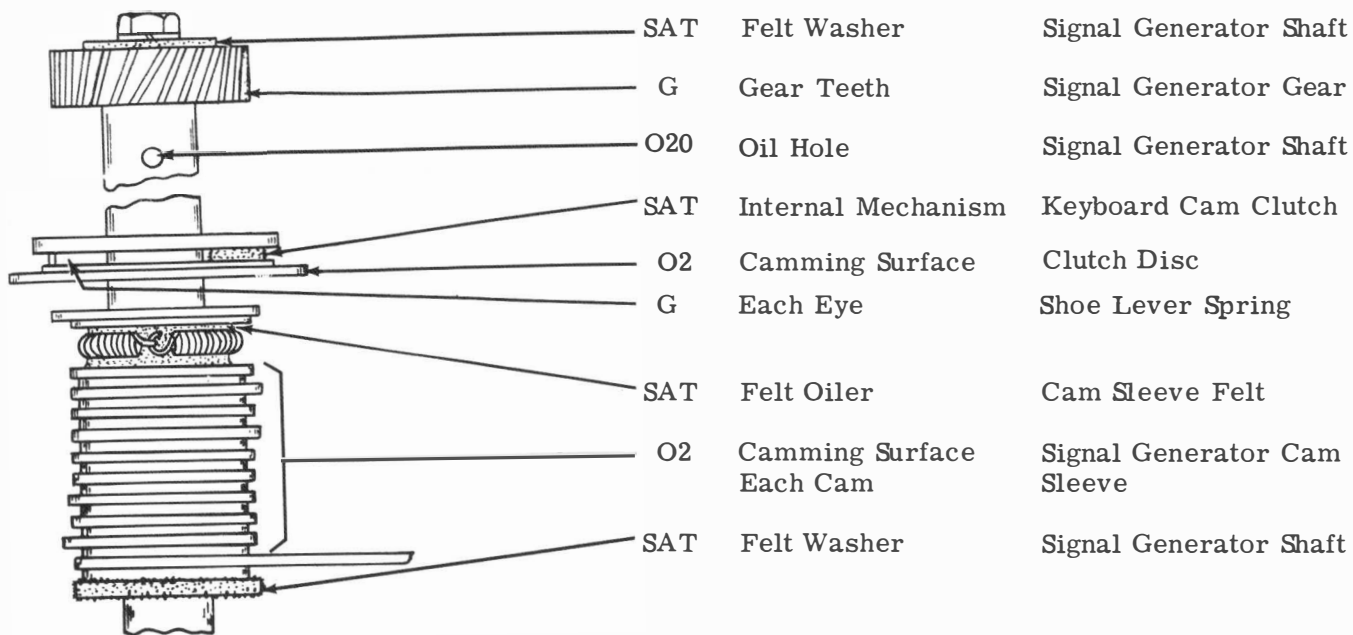

4.19 Intermediate Levers

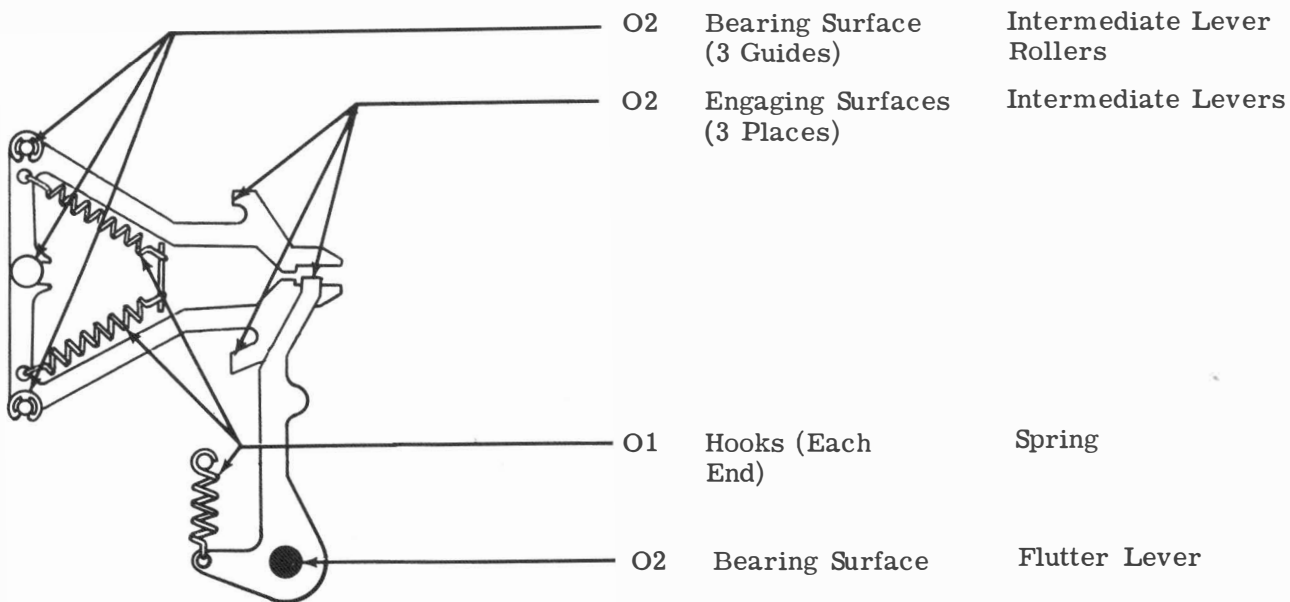

4.20 Signal Generator Mechanism

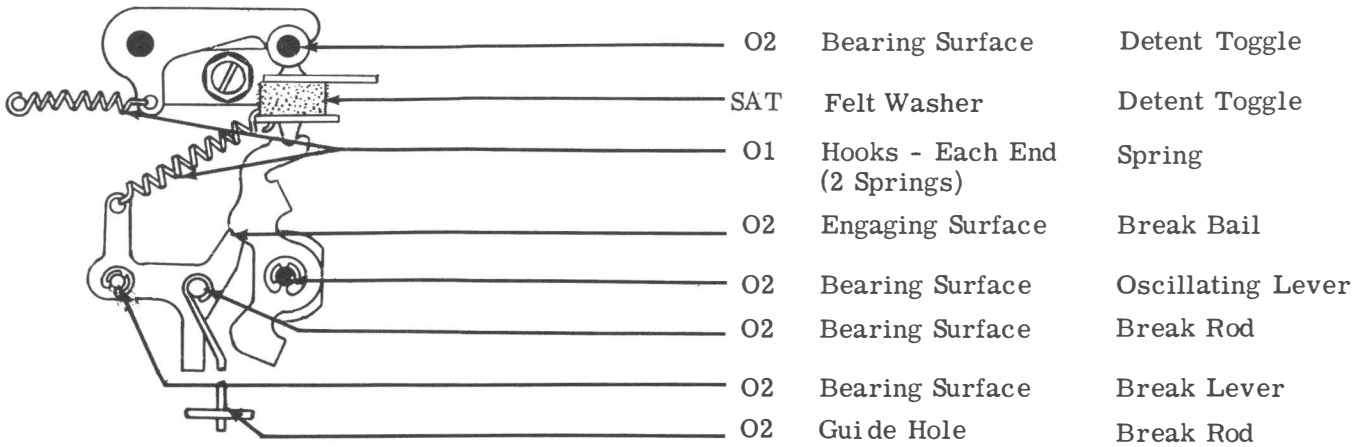

4.21 Signal Generator Clutch

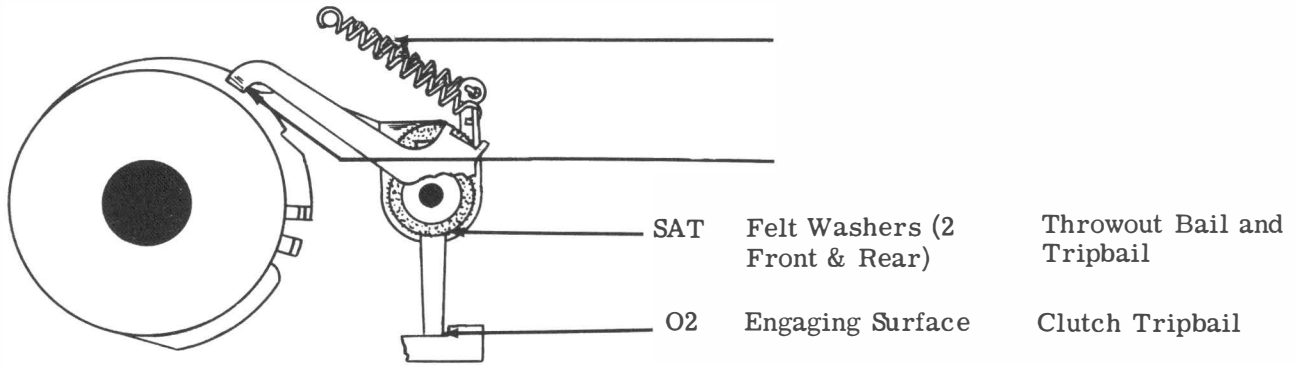

4.22 Time Delay Mechanism

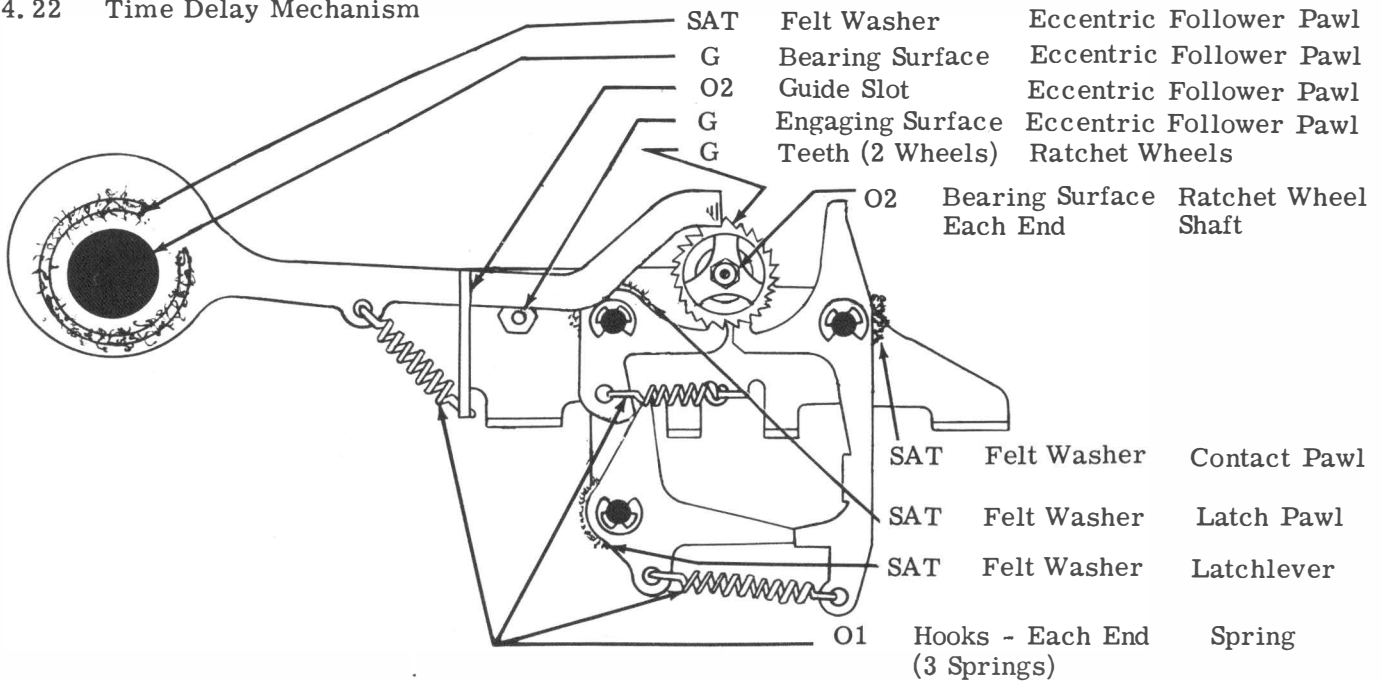



4.23 Paper Feed-Out Mechanism - Top View

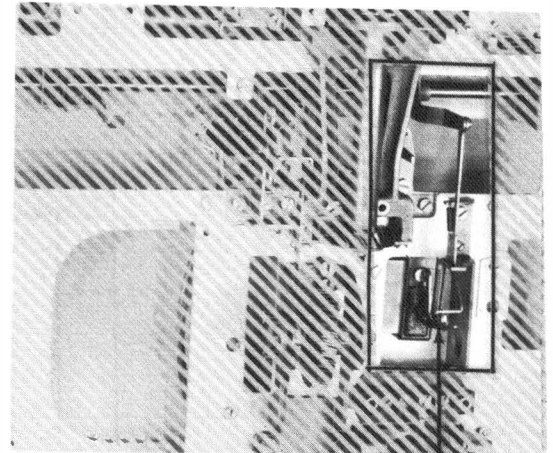

4.24

4.24 Paper Feed-Out

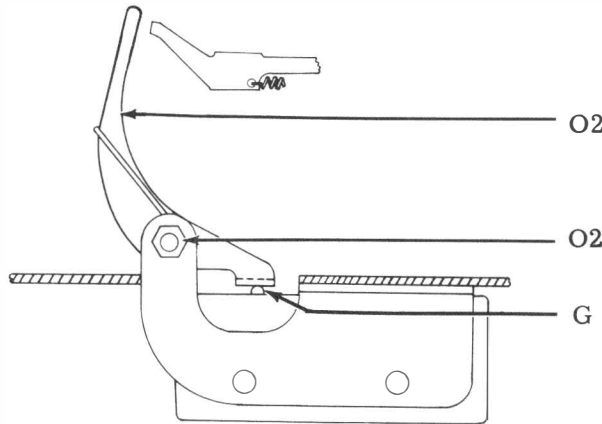

- O2 Bearing Surface Switch Lever
- O2 Pivot Point Torsion Spring
- G Engaging Surface Thin Film Switch Plunger

4.25 Answer-Back Blinding (Pulsing) Contact (not shown on Locator Photograph)

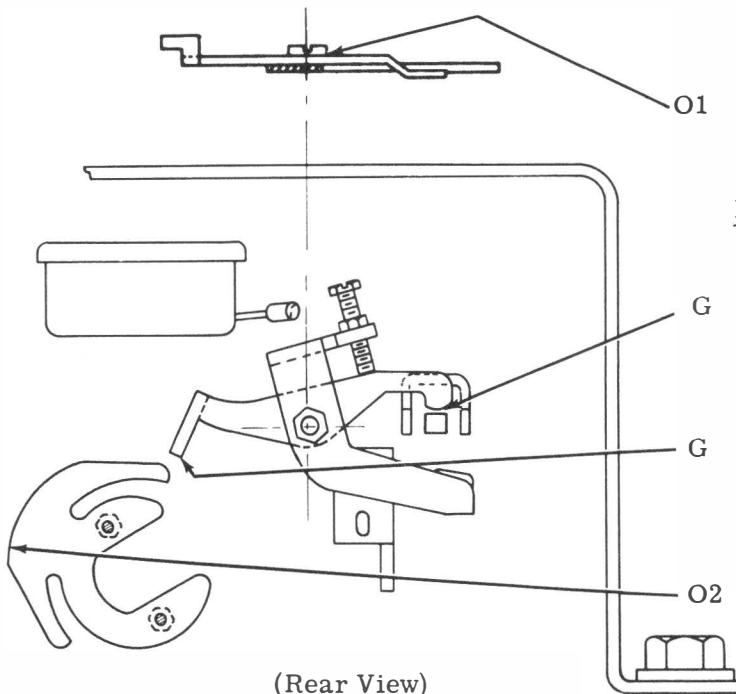

- O1 Head of Shoulder Screw Finger Pivot (Do Not Over Lubricate)

Note: Keep oil and grease off of contacts

- G Contacting Surface Finger and Swinger
- G Camming Surface Finger Extension
- O2 Contacting Surface Cam

(Rear View)

4.26 Answer-Back Drive Mechanism

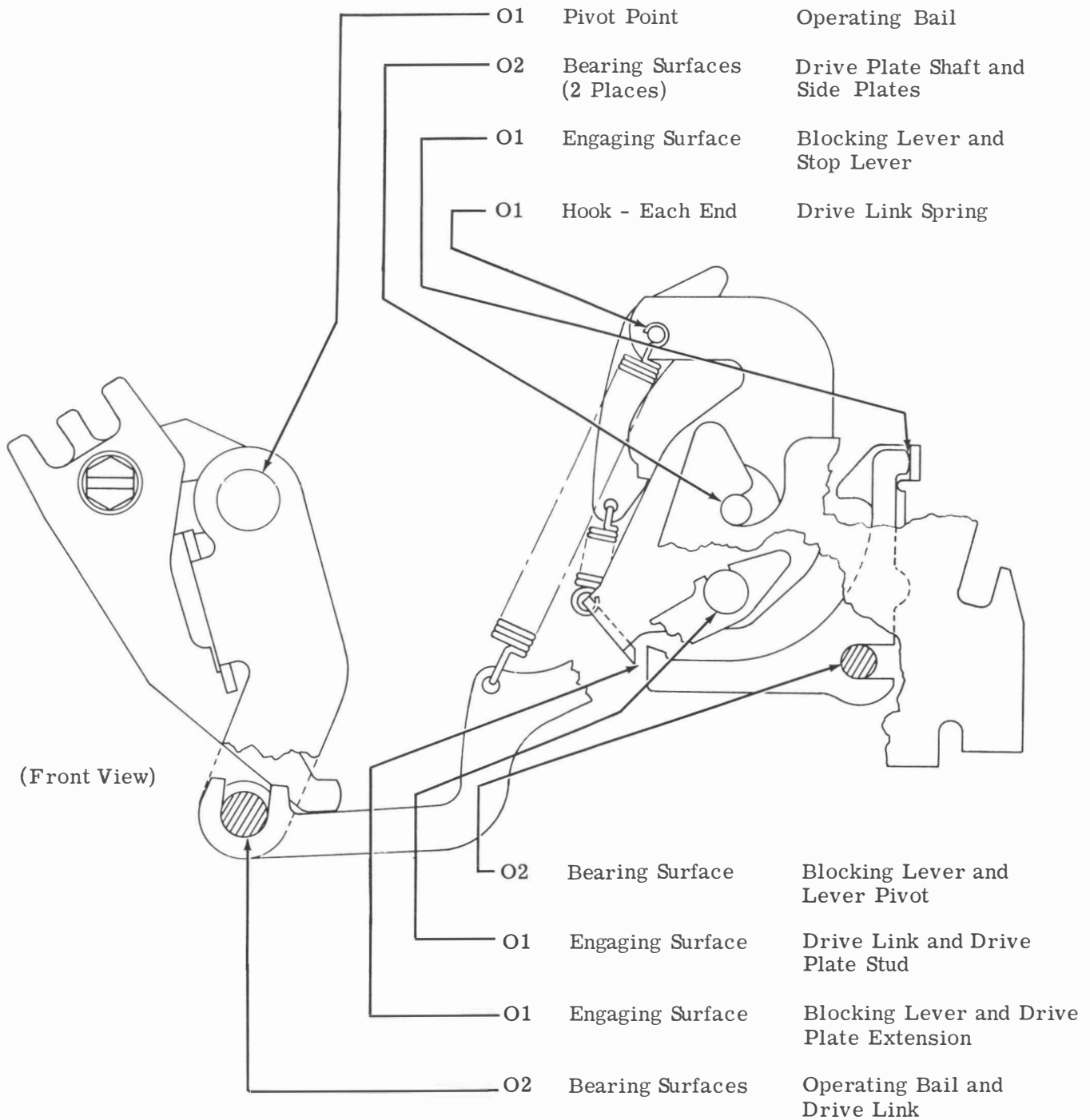

4. 27 Answer-Back Drive Mechanism (Continued)

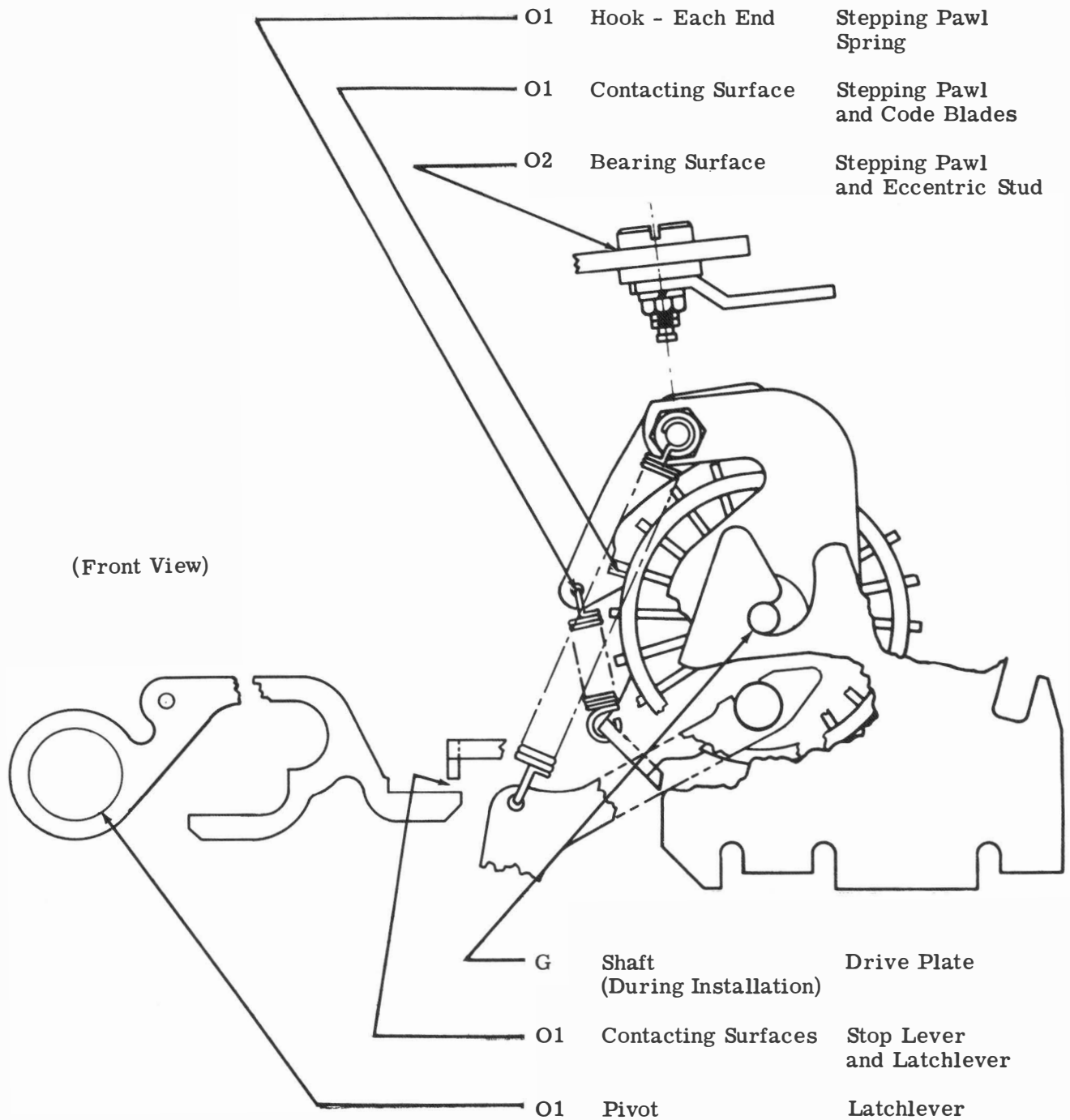

Note: Lubricate Sensing Lever and Codebar Mechanisms per Paragraphs 3. 05, 3. 06, 3. 07 and 3. 08.

4.28 Repeat Space and Signal Line Break - Left Rear View

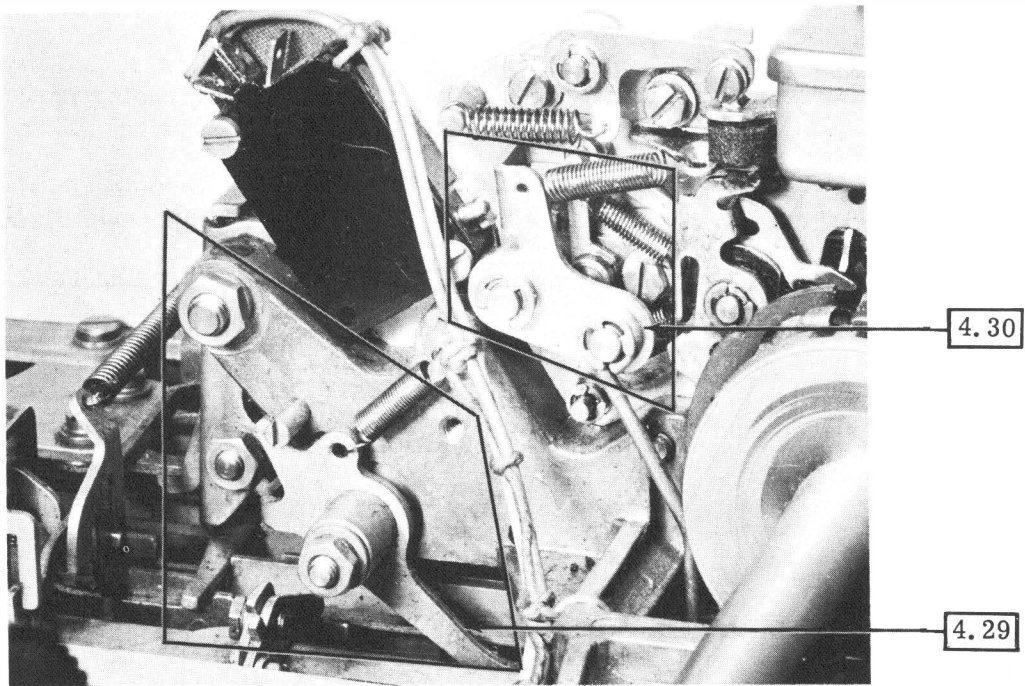

4.29 Repeat on Space

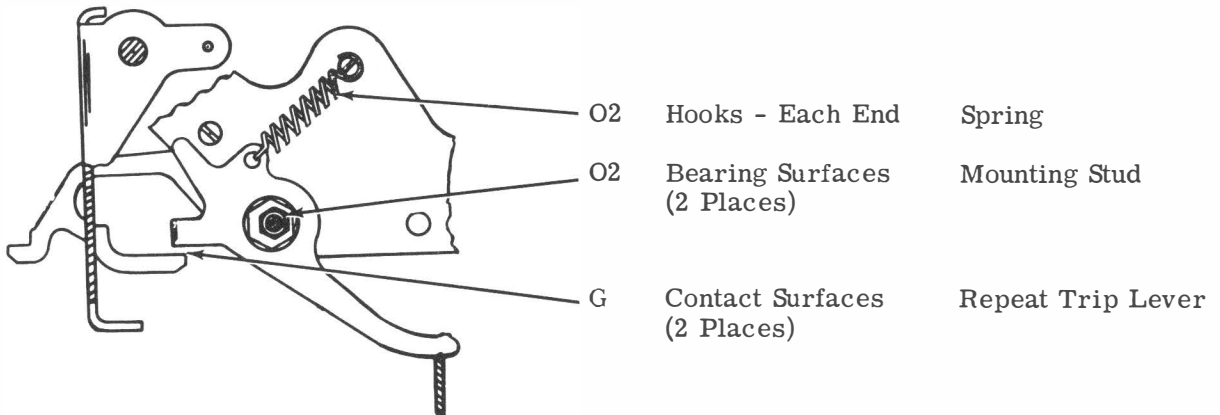

4.30 Signal Line Break (Electrical)

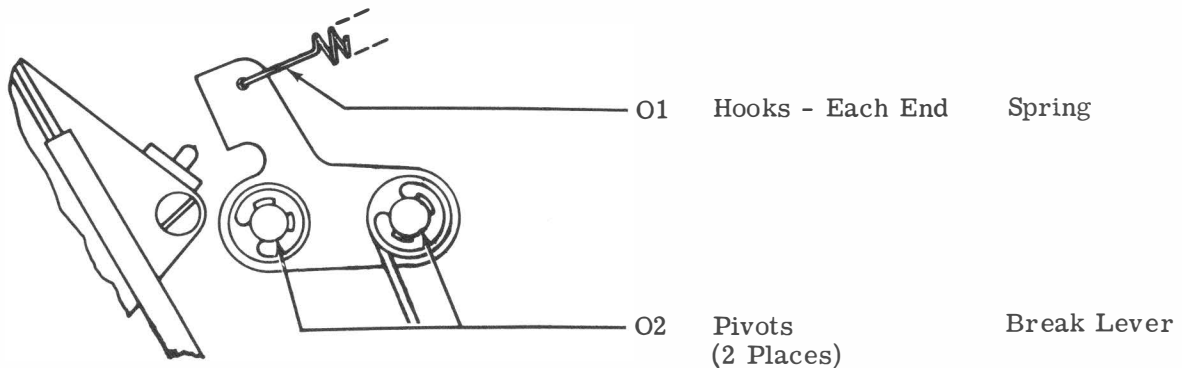

5. RECEIVE-ONLY (RO) BASE

5.01 Signal Line Break

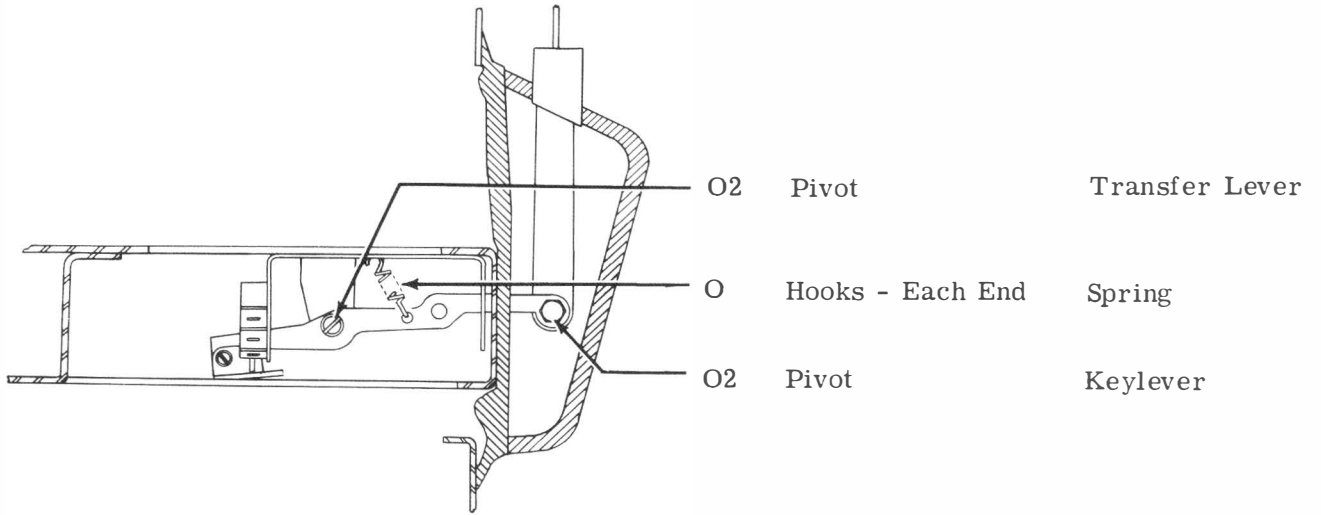

5.02 Signal Line Break Mechanism - Left Top View

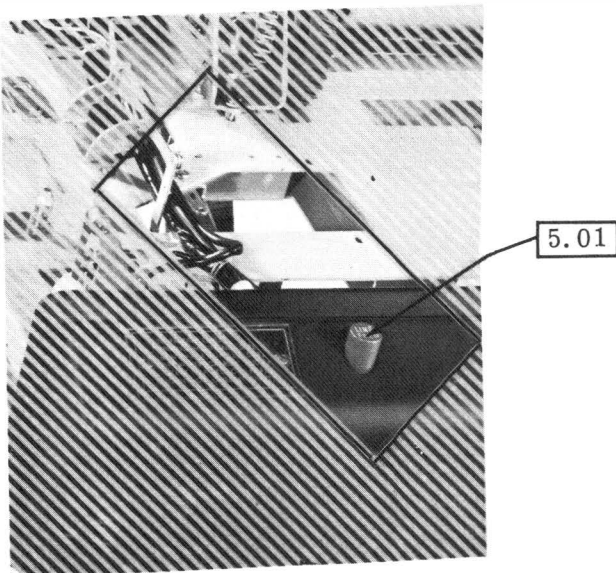



Handwritten scribbles and faint markings.



Vertical handwritten marks, possibly the number '1'.

