

28 TELETYPEWRITER BASE

(KEYBOARD SEND-RECEIVE AND RECEIVE ONLY)

LUBRICATION

CONTENTS	PAGE	CONTENTS	PAGE
1. GENERAL	1	3. EARLIER DESIGN KSR BASE (KEYBOARD).....	34
2. LATER DESIGN KSR BASE (KEYBOARD)	3	Answerback: blinding (pulsing) contacts	48
Answerback: armature	19, 20	Answerback: driving mechanism...	49
Answerback: codebars and sensing levers	19, 22	Codebar	37, 38
Answerback: driving mechanism...	19, 23	Codebar bail and eccentric follower	37, 39
Answerback: sensing levers.....	19, 21	Codelever	34, 35
Answerback: stepping pawl	19, 23	Codelever bail	37, 39
Answerback: stoplever	19, 20	Contact box	37, 38
Blinding (pulsing) contacts - camfollower mechanism.....	24, 25	Intermediate gears	40, 41
Breaklever.....	3, 5	Intermediate lever (signal generator)	42, 44
Codebar	6, 7	Keyboard lock	34, 36
Codebar bail	13, 15	Keyboard selector	37, 39
Codelever	3, 5	Local carriage return.....	34, 35
Codelever universal bail	16, 17	Local line feed	34, 36
Contact box	8, 10	Margin indicator	37, 38
Electrical line break	16, 17	Paper feedout	47, 48
Electrical send-receive break mechanism.....	26	Repeat-space mechanism	45, 46
Form feedout	29, 30	Shaft	40, 41
Function clutch.....	8, 11	Signal generator	42, 43
Intermediate gears	8, 12	Signal generator clutch	42, 43
Keyboard lock	3, 5	Signal line break mechanism.....	45, 46
Keylever.....	3, 4	Time delay mechanism.....	42, 43
Local carriage return.....	6, 7	4. RECEIVING-ONLY (RO) BASE	50
Local line feed	8, 12	Signal line break mechanism.....	50, 51
Lockbar latch	16, 17	1. GENERAL	
Locking bail	13, 14	1.01 This section provides the specific lubri- cation for the maintenance of the 28 tele- typewriter base (KSR base and RO base) including variable and auxiliary features. Teletypewriter bases of the KSR type are also referred to as keyboards. This section and the section covering teletypewriter general lubrication give the com- plete information for lubricating the unit.	
Margin indicator	8, 11	1.02 The section is reissued to:	
Nonrepeat lever	8, 9	(a) Add a more detailed table of contents.	
Paper feedout	16, 18		
Remote control gear shift	27, 28		
Repeat-space mechanism.....	24, 26		
Shaft	8, 11		
Spacebar	3, 4		
Transfer bail	8, 10		
Transfer lever	8, 9		
Universal bail latchlever	13, 14		
Universal keyboard switch	33		
Variable speed drive - speed selecting mechanism.....	31, 32		

SECTION 573-116-701

(b) Improve the locator photographs by labeling the identifying arrows with the names of the mechanisms instead of paragraph numbers.

(c) Revise 2.16.

(d) Add six new locator photographs (2.29, 2.37, 2.41, 2.43, 2.45, and 4.01) and seven line drawings (2.11, 2.40, 2.46, 2.47, 3.26, 3.27, and 3.28).

1.03 The lubrication symbols used herein are the same as those in the teletypewriter general lubrication section. However, the symbol O is used in this section to mean only one drop of oil. The symbol O2 is used to specify 2 drops of oil.

1.04 The keyboard or base should be lubricated before being placed in service as specified in the section covering preparation of the tele-

typewriter apparatus for installation. After a few weeks in service, it should ordinarily be relubricated to make certain that all the specified points have received lubricant. Thereafter, because of the varying conditions at each station, the keyboard or base should be lubricated as often as specified by the local instructions. The following lubrication intervals are suggested as a guide for use under normal operating conditions.

<u>Operating Speed</u> (Words per Minute)	<u>Lubricating Intervals</u> (Whichever occurs first)
60	3000 hours or 1 year
75	2400 hours or 9 months
100	1500 hours or 6 months

2. LATER DESIGN KSR BASE (KEYBOARD)

2.01 Spacebar, Keylever, Breaklever, Keyboard Lock, and Codelever Mechanisms

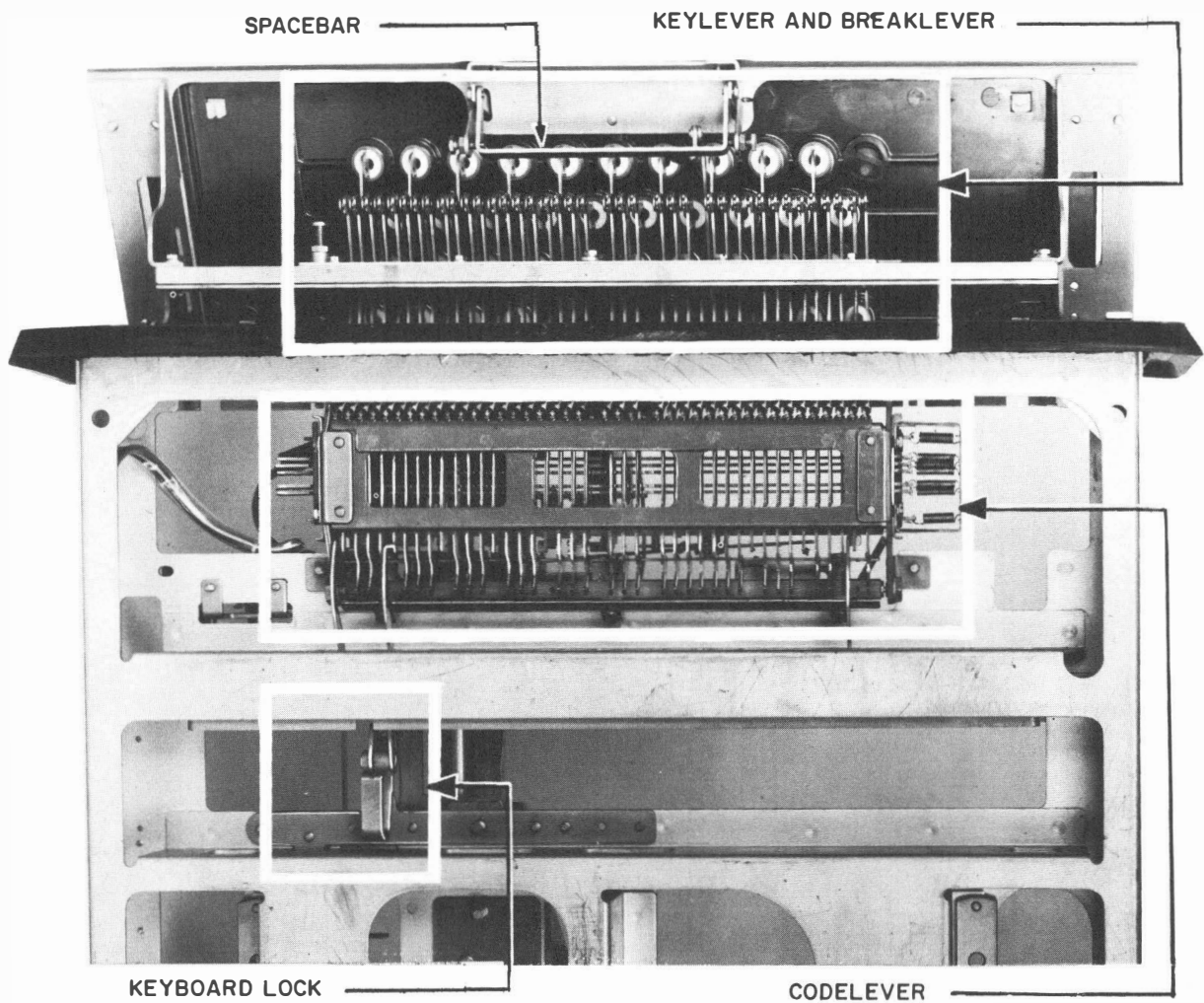

2.02 Spacebar

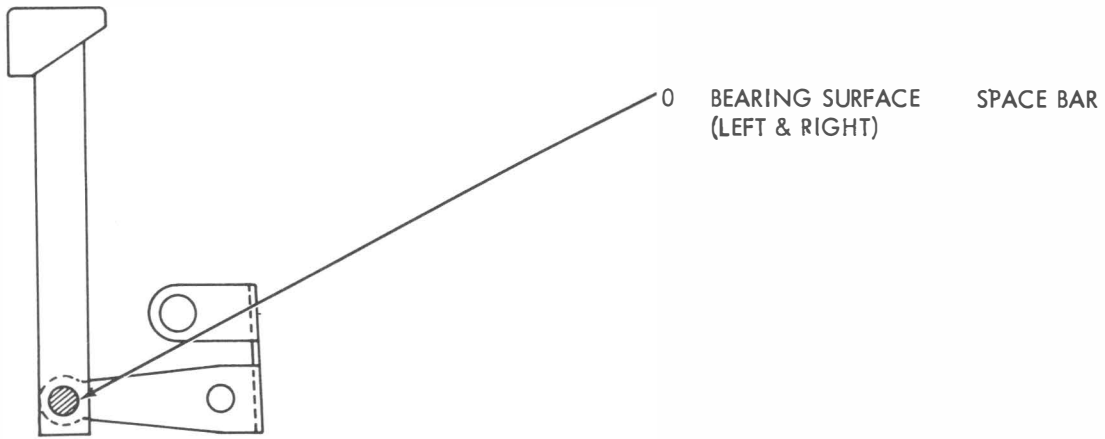

2.03 Keylever

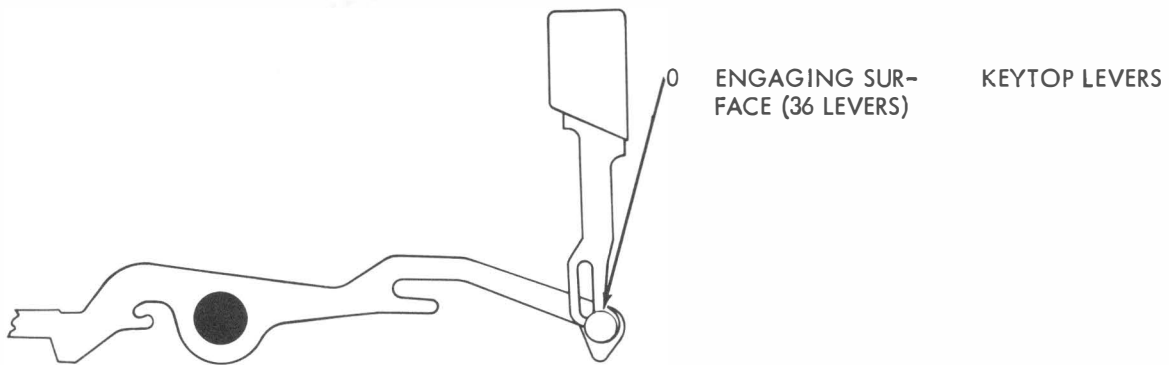

2.04 Breaklever

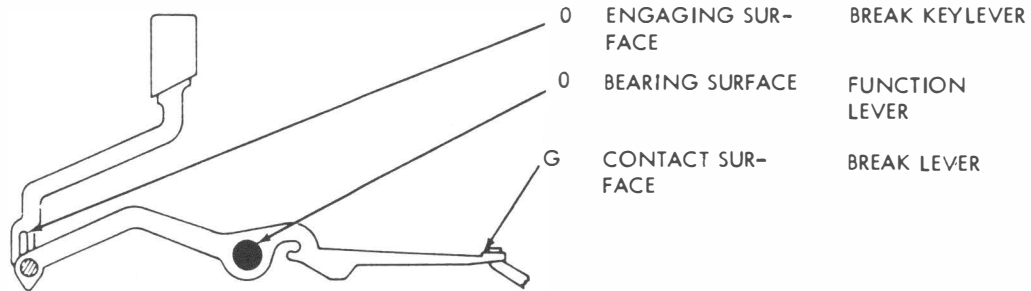

2.05 Keyboard Lock

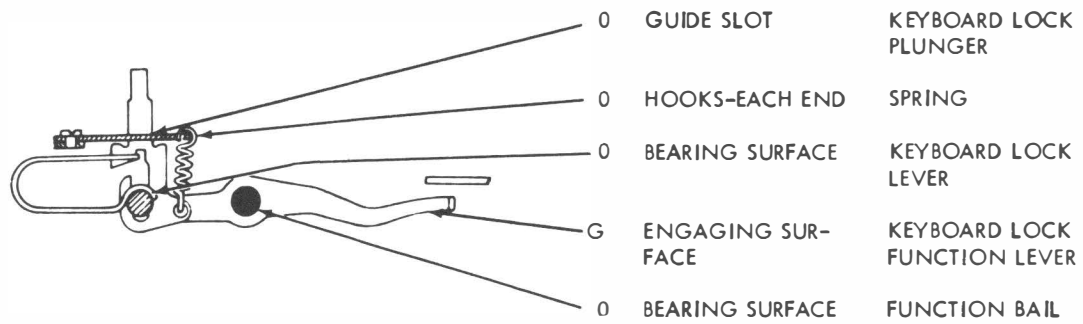

2.06 Codelever

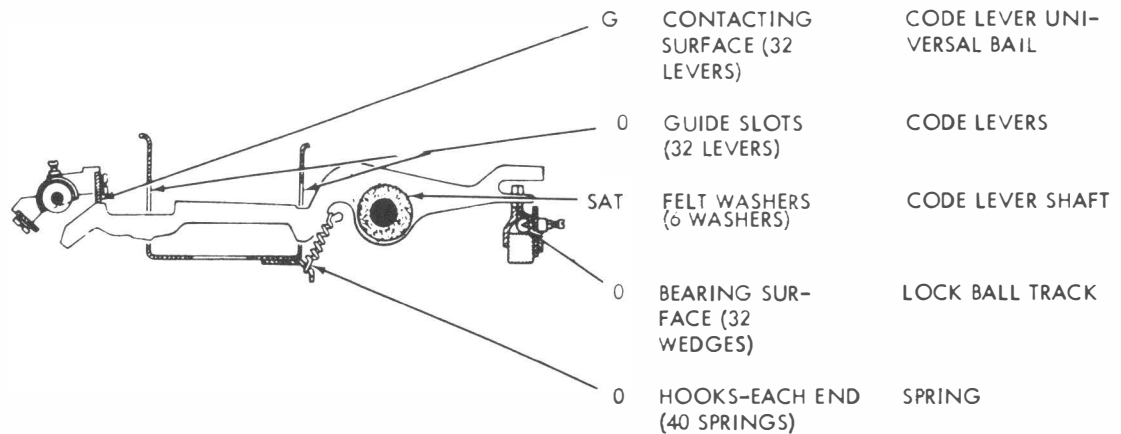

2.07 Codebar and Local Carriage Return Mechanisms

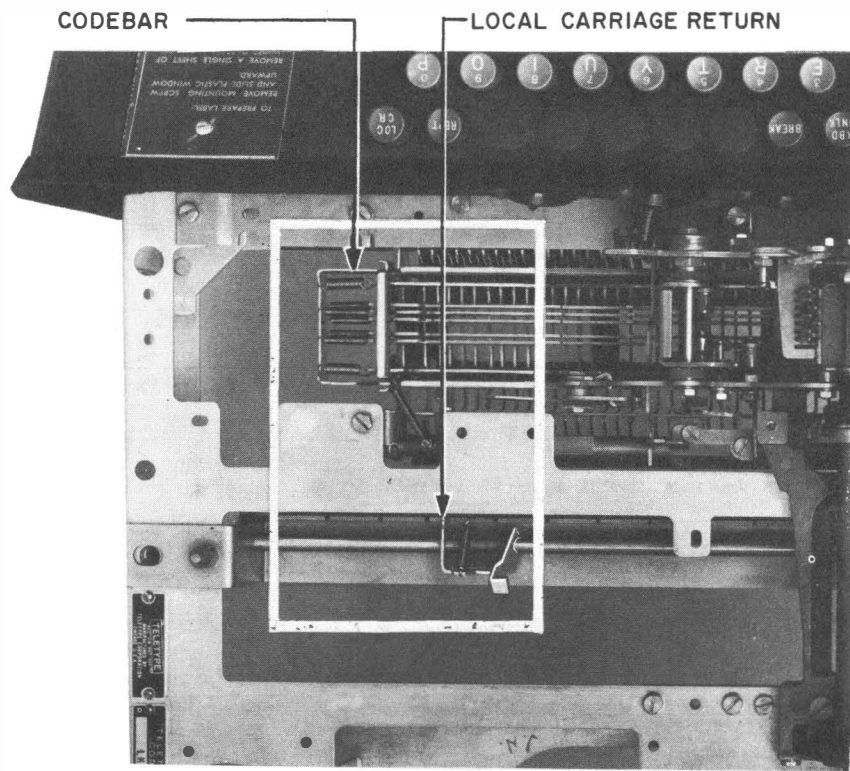

2.08 Codebar

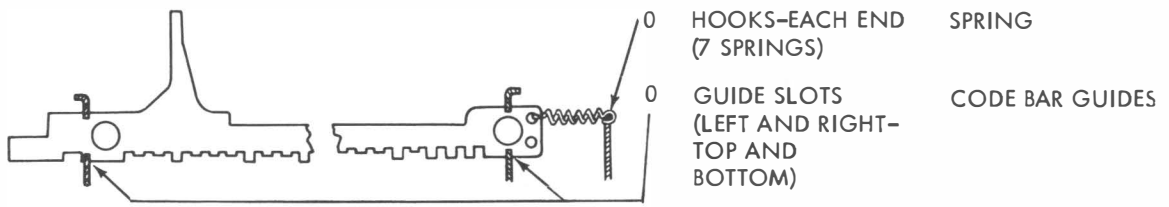

2.09 Local Carriage Return

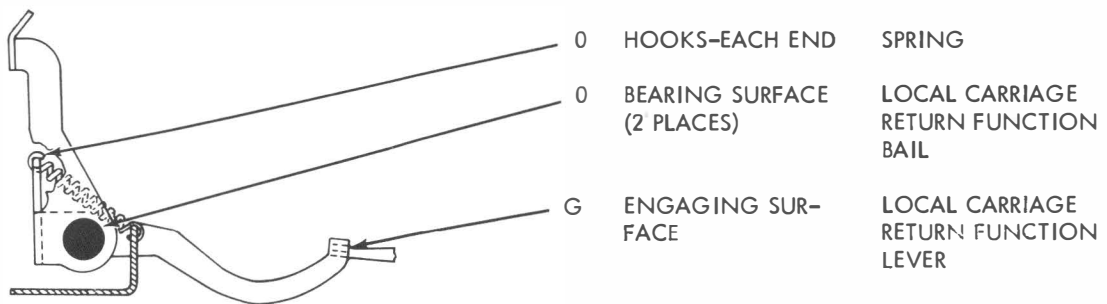

2.10 Nonrepeat Lever, Transfer Lever, Contact Box, Transfer Bail, Function Clutch, Margin Indicator, Shaft, Local Line Feed, and Intermediate Gear

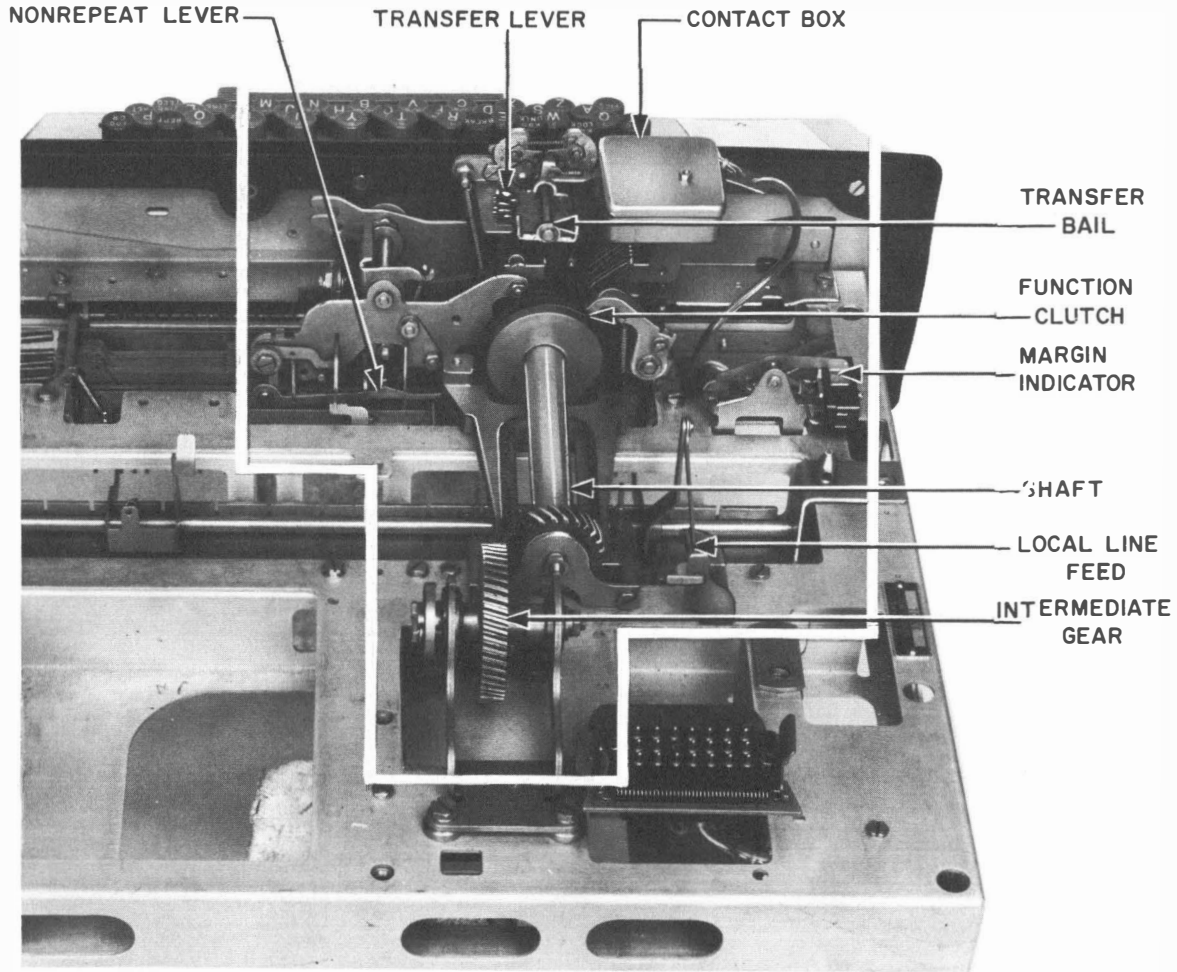

2.11 Nonrepeat Lever (Later Design)

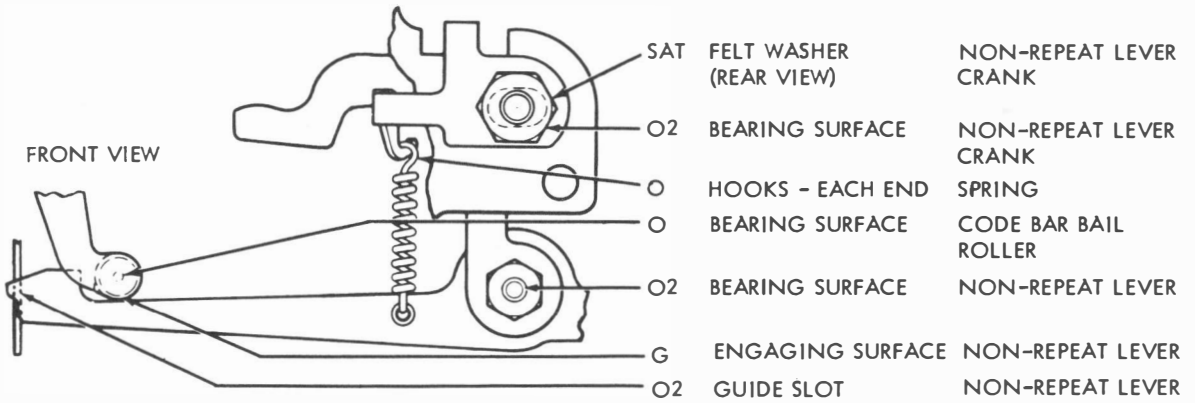

2.12 Transfer Lever

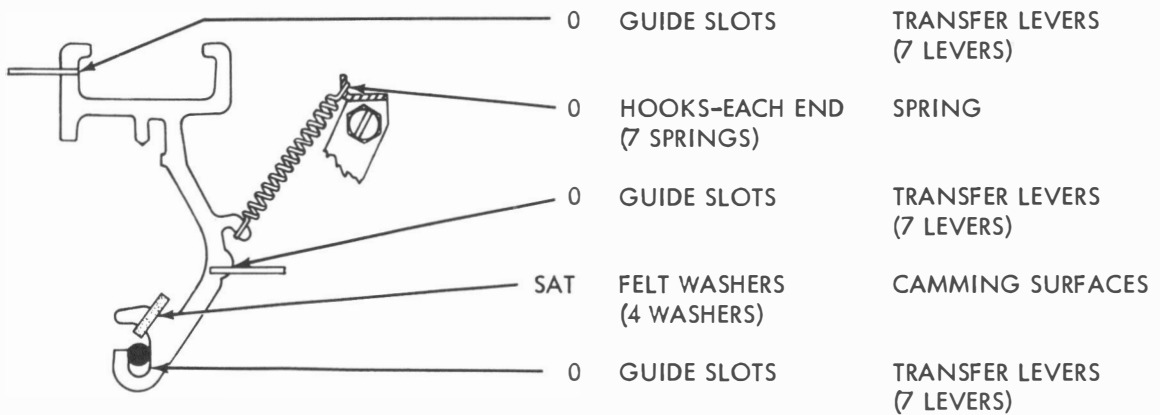

2.13 Contact Box

Note: Grease sparingly. Keep contacts free of oil or grease.

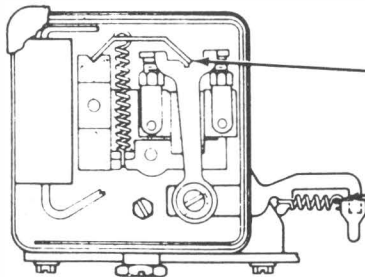

G ENGAGING SUR- CONTACT TOGGLE
FACE

0 HOOKS-EACH END SPRING

DISASSEMBLY: REMOVE NUT AND LOCK WASH-
ER SECURING CONTACT BOX
COVER AND REMOVE COVER.

2.14 Transfer Bail

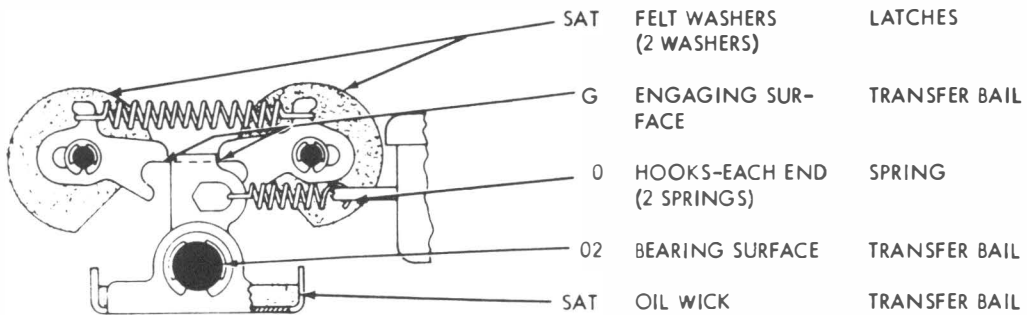

SAT FELT WASHERS LATCHES
(2 WASHERS)

G ENGAGING SUR- TRANSFER BAIL
FACE

0 HOOKS-EACH END SPRING
(2 SPRINGS)

02 BEARING SURFACE TRANSFER BAIL

SAT OIL WICK TRANSFER BAIL

2.15 Function Clutch

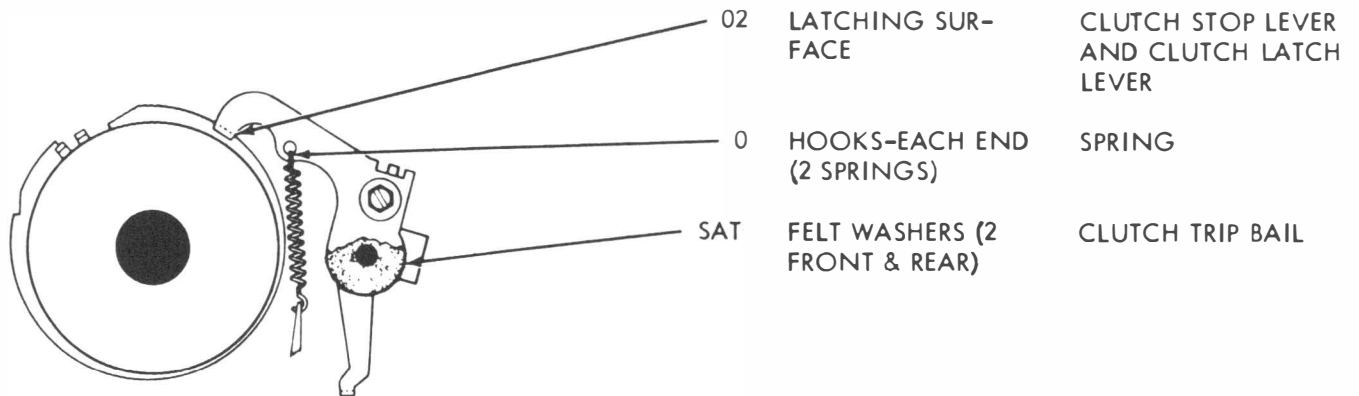

2.16 Margin Indicator (Front View)

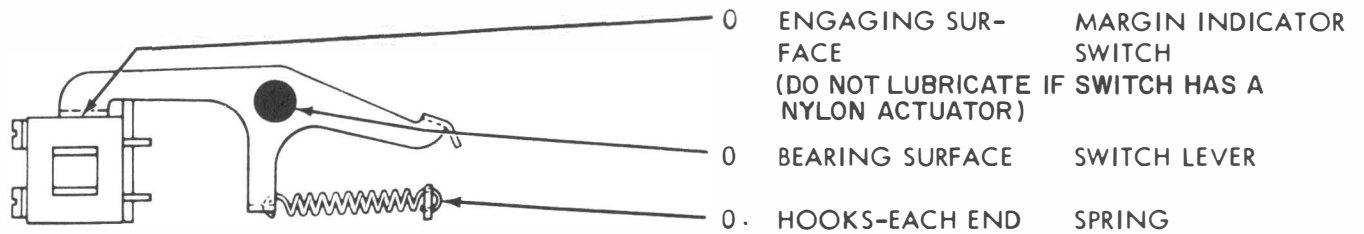

2.17 Shaft

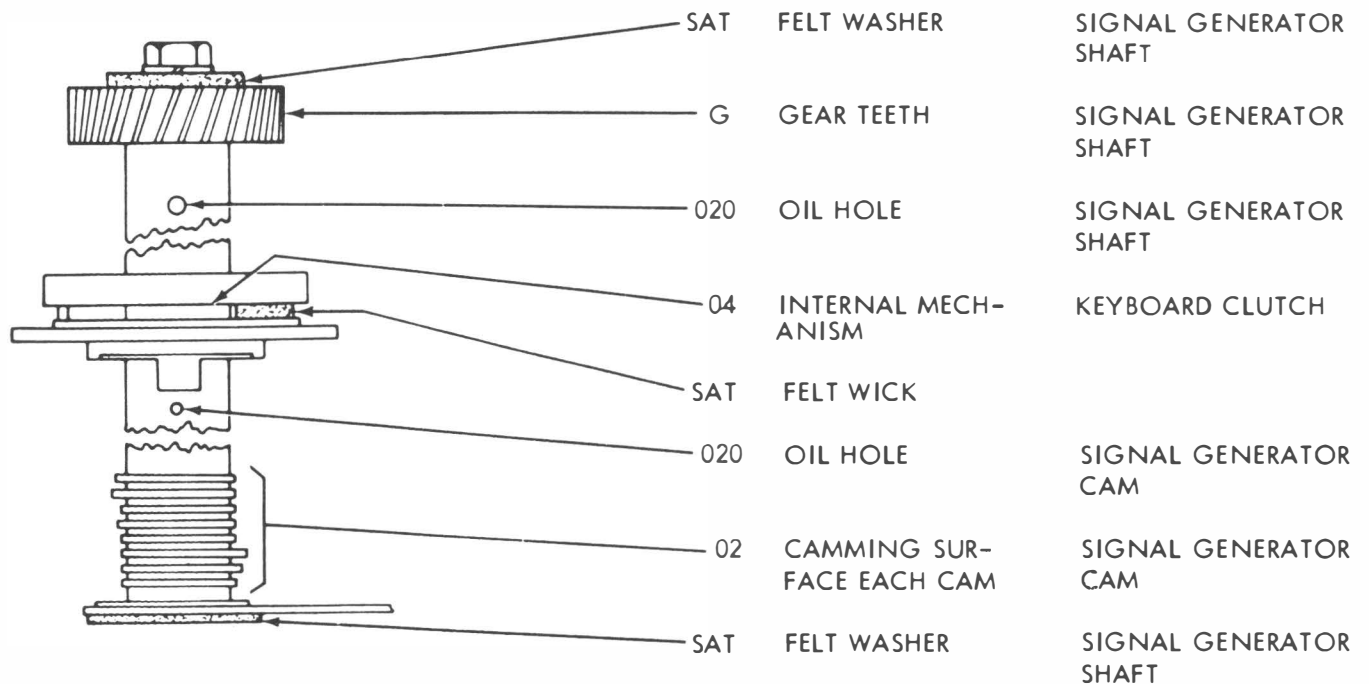

2.18 Local Line Feed

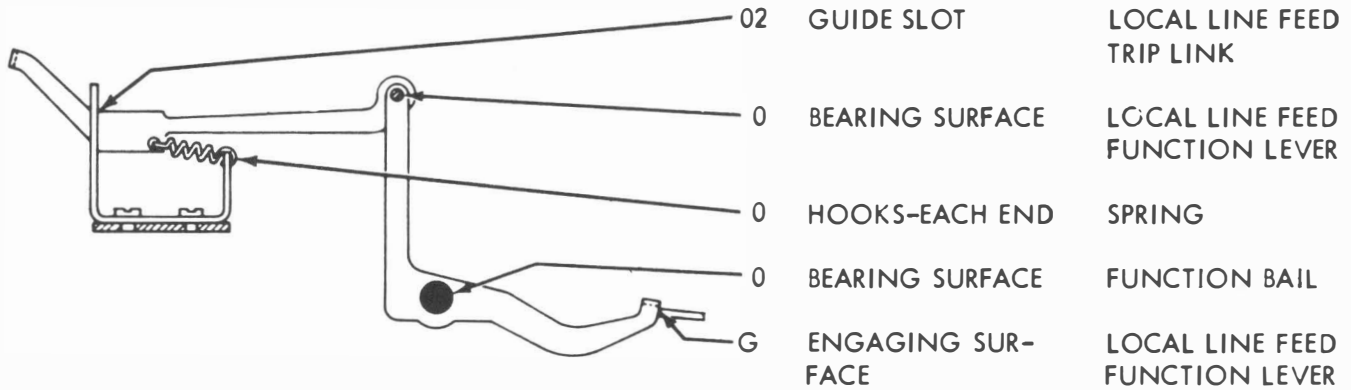

2.19 Intermediate Gears (For motor, see section entitled Motor Unit, Lubrication)

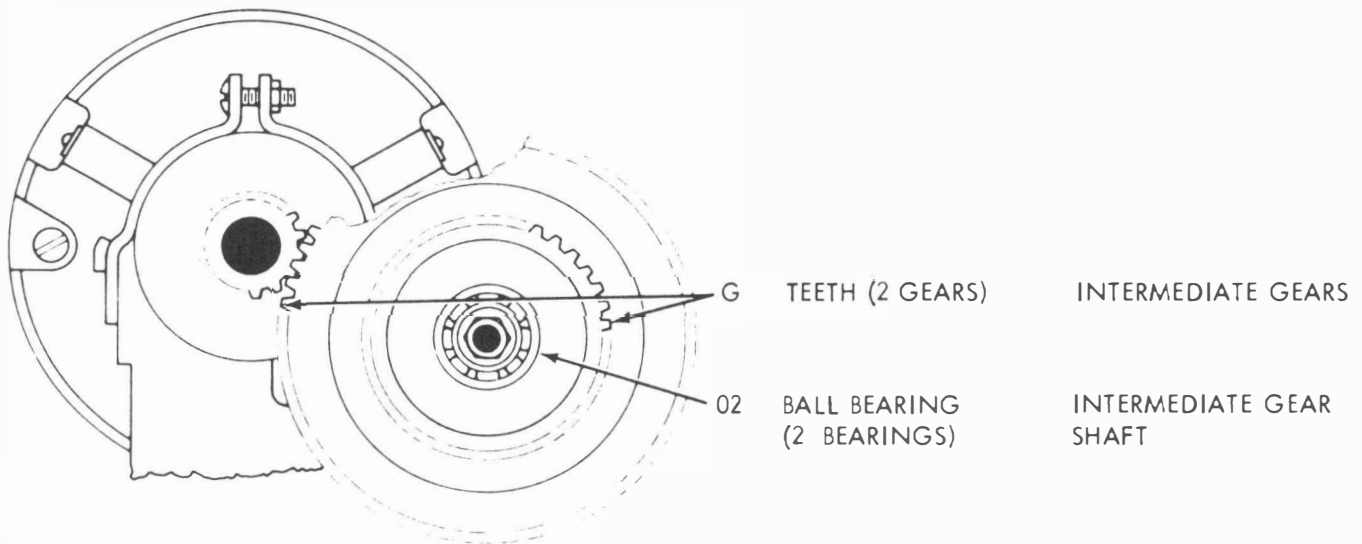

2.20 Locking Bail, Universal Bail Latchlever and Codebar Bail

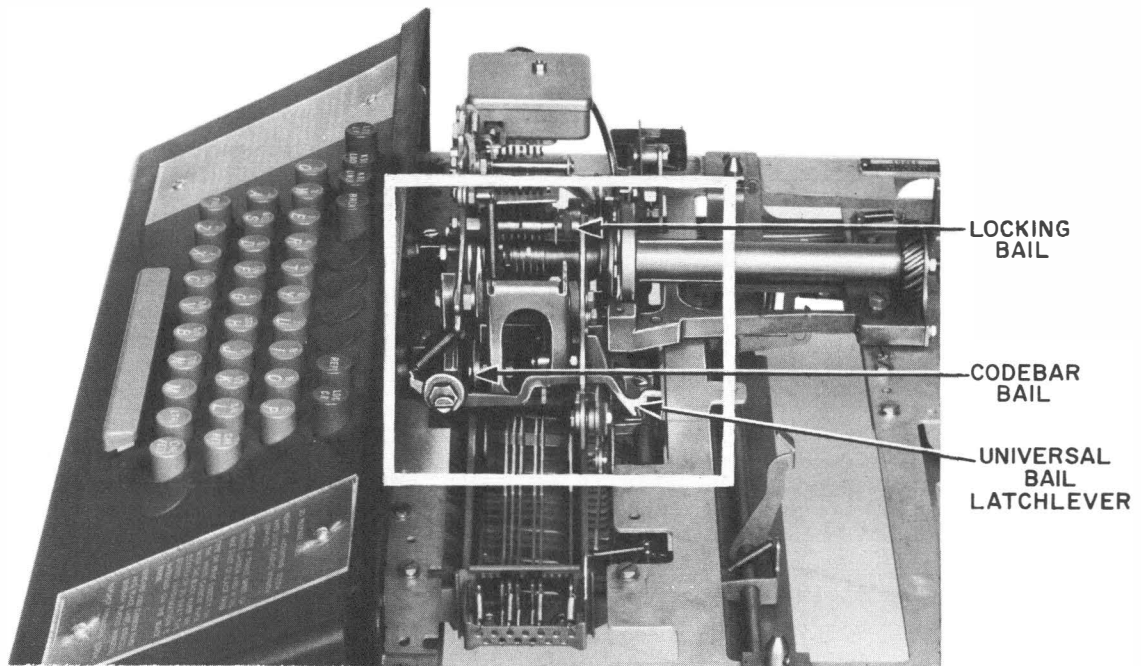

2.21 Locking Bail

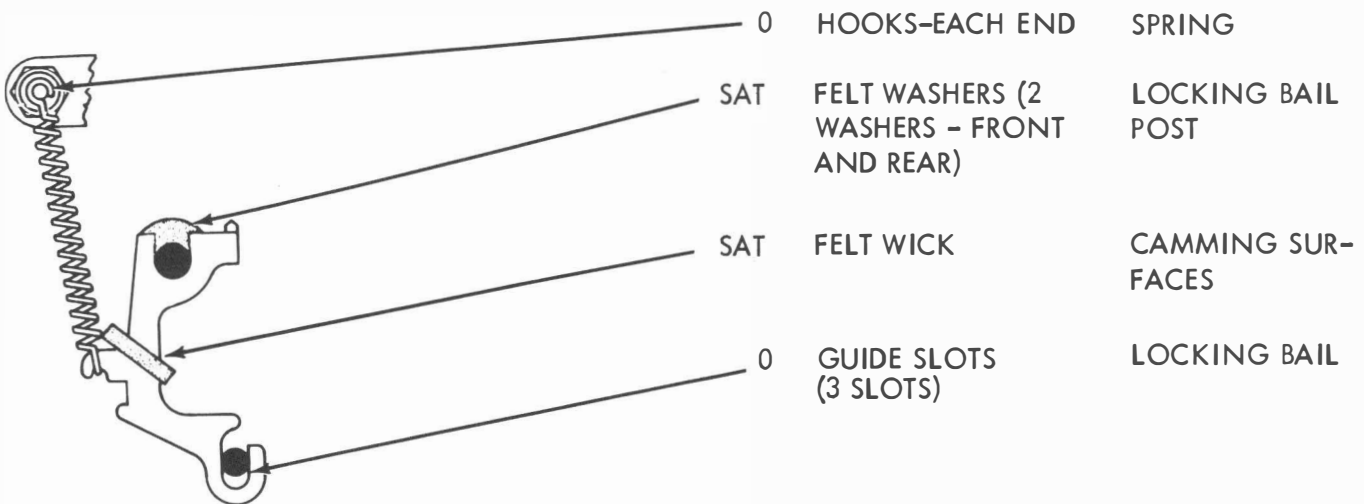

2.22 Universal Bail Latchlever

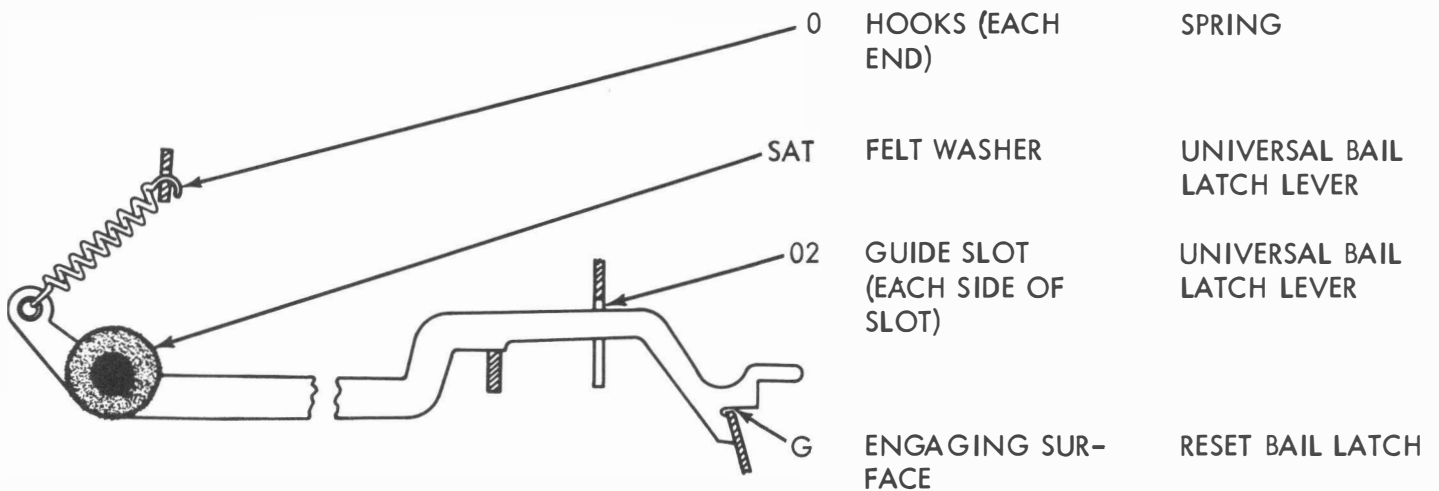

2.23 Codebar Bail

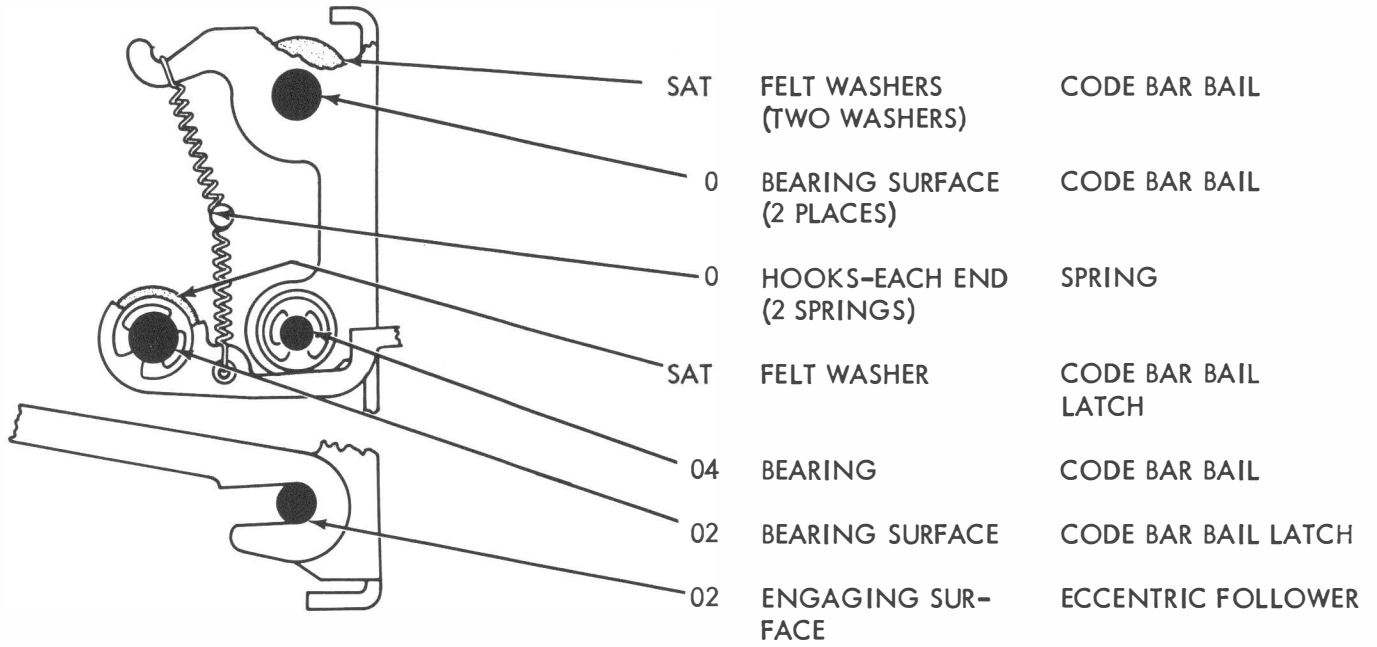

2.24 Electrical Line Break, Codelever Universal Bail, Lockbar Latch and Paper Feedout Mechanisms

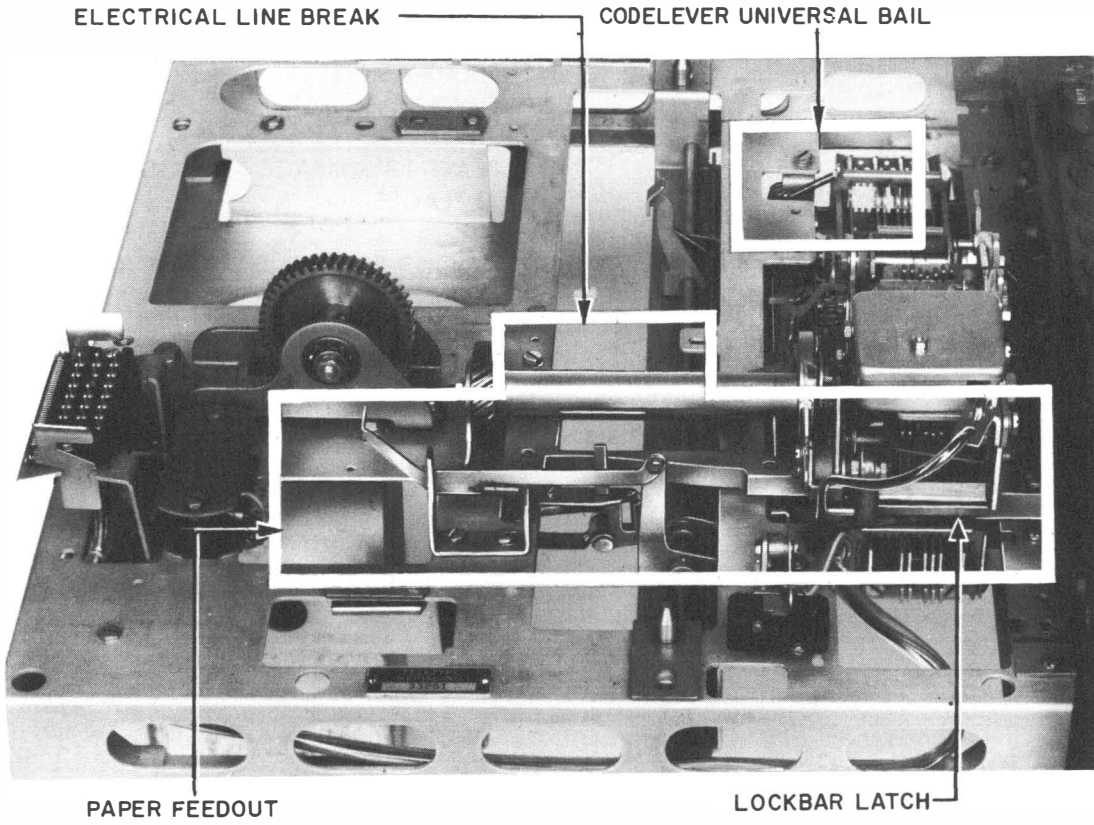

2.25 Electrical Line Break

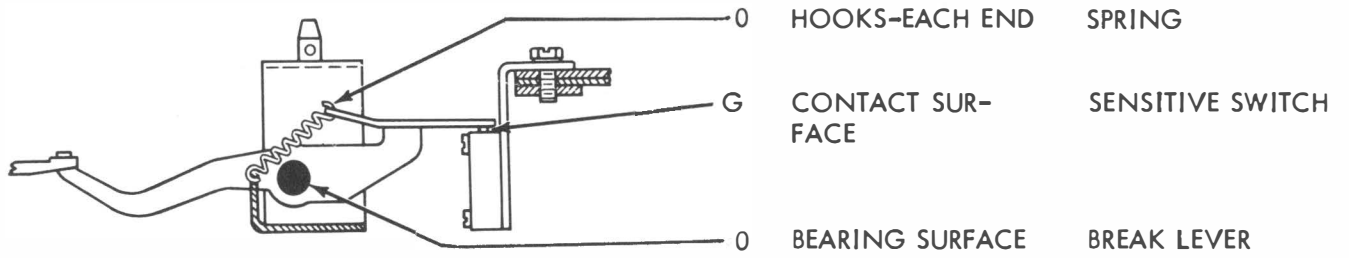

2.26 Codelever Universal Bail

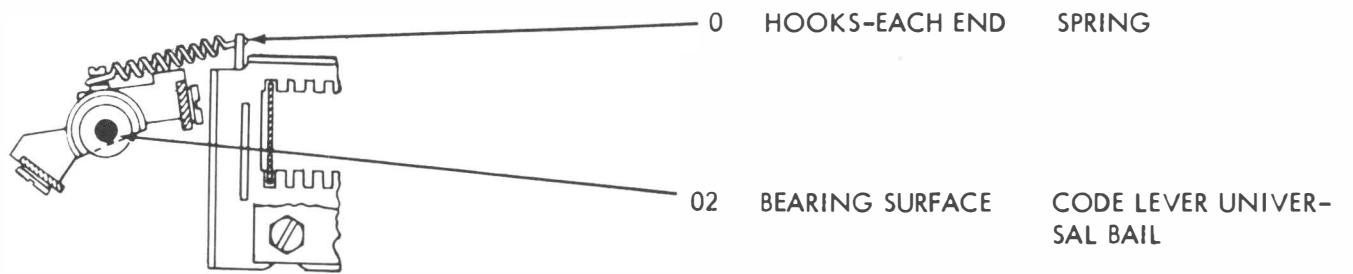

2.27 Lockbar Latch

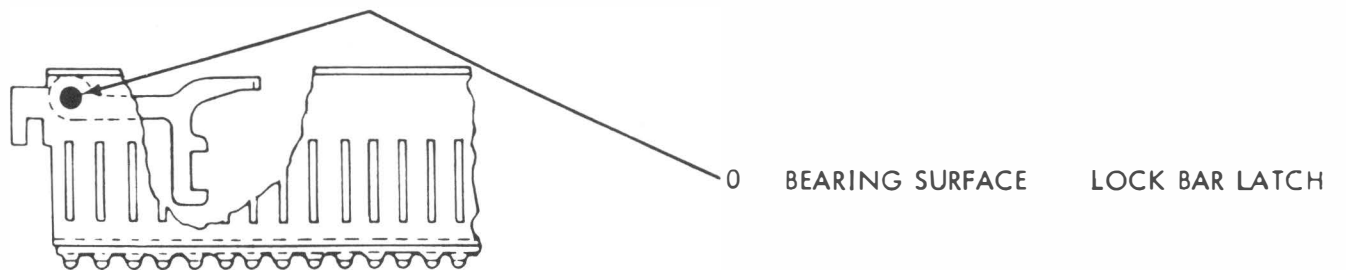

2.28 Paper Feedout

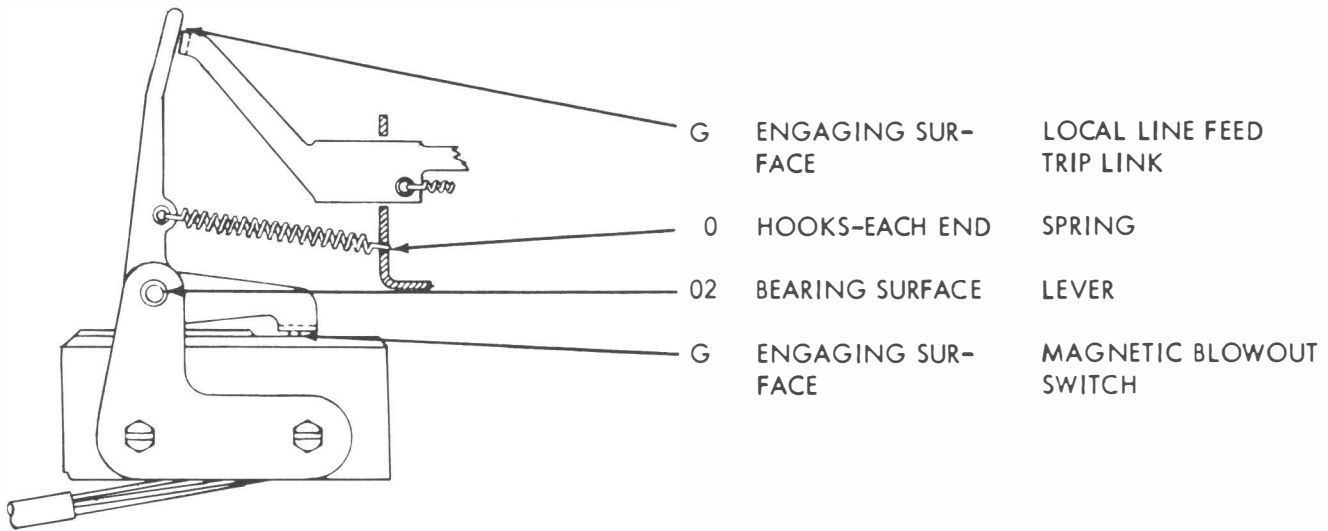

2.29 Answerback Mechanism

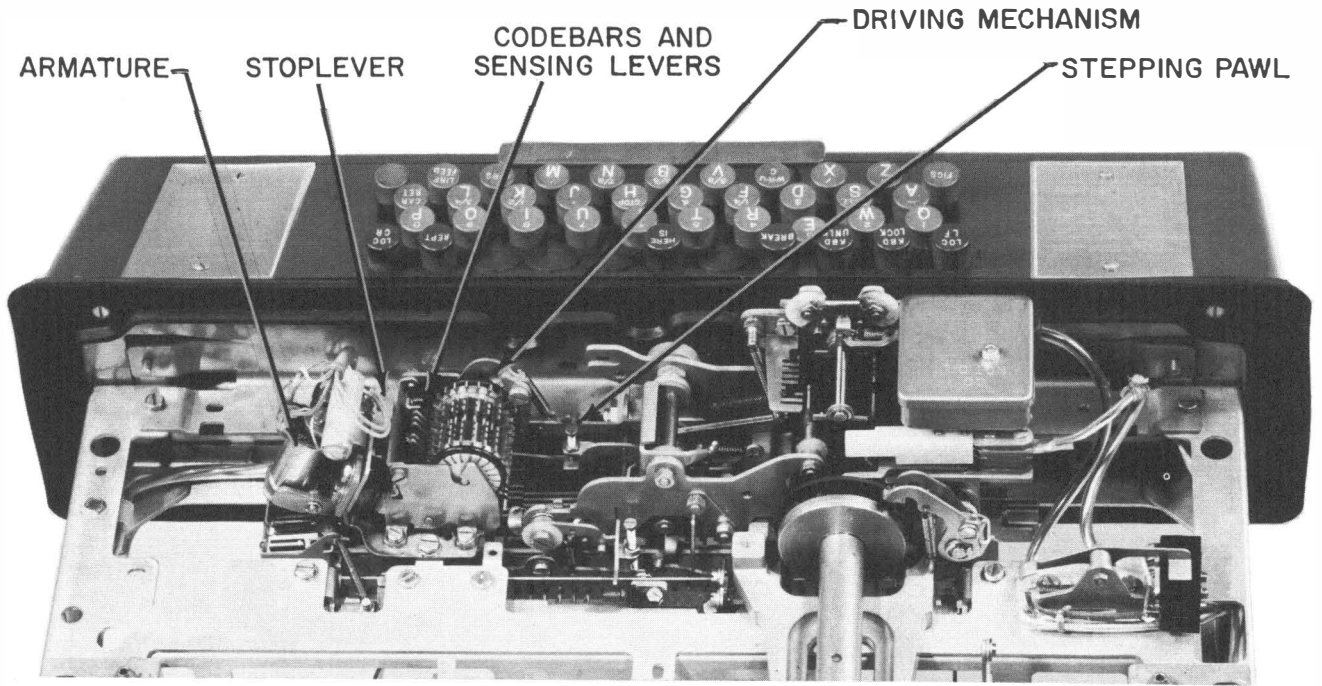

2.30 Answerback: Armature

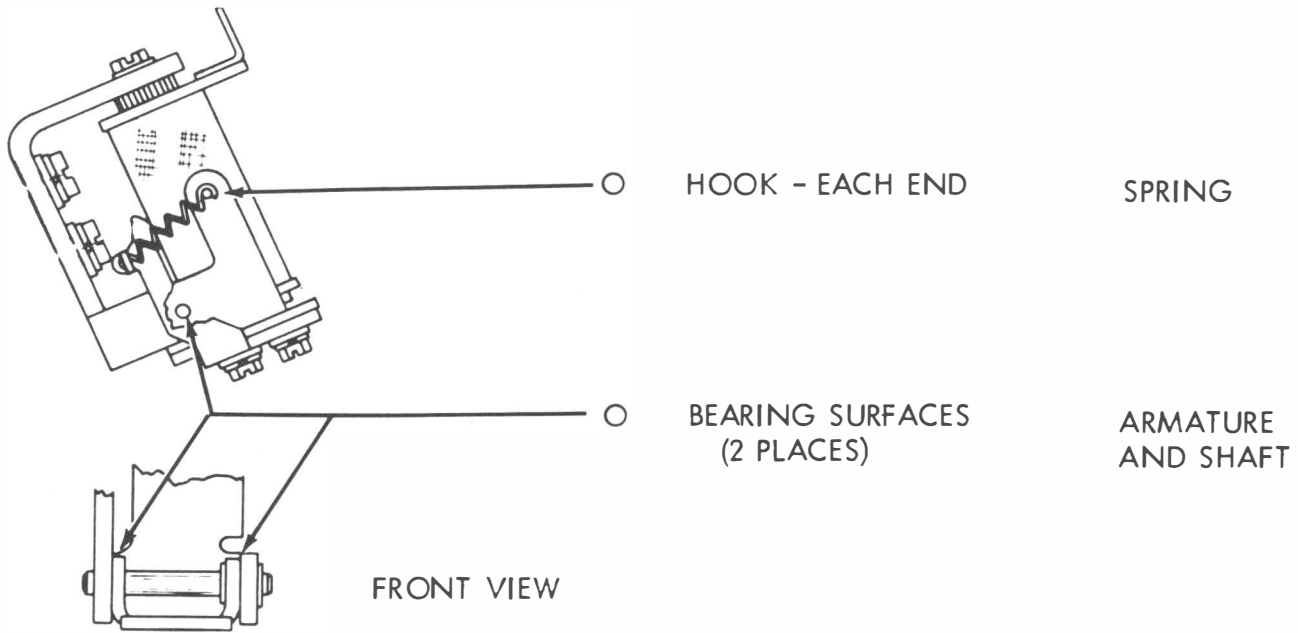

2.31 Answerback: Stoplever

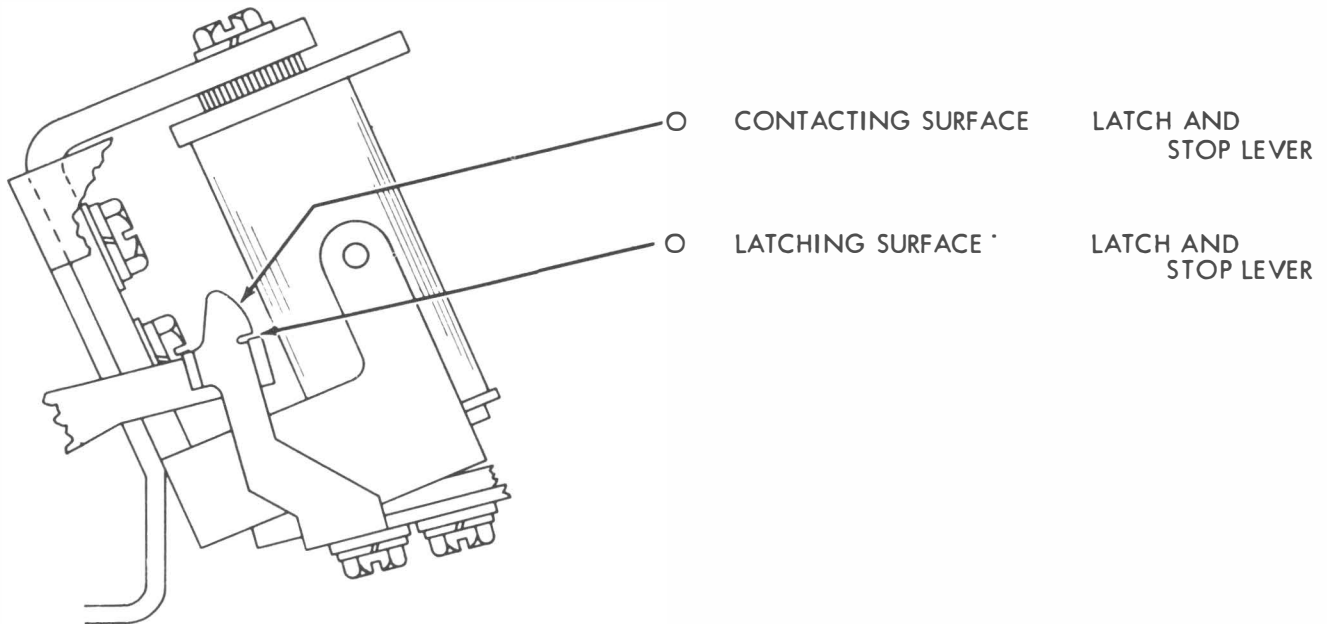

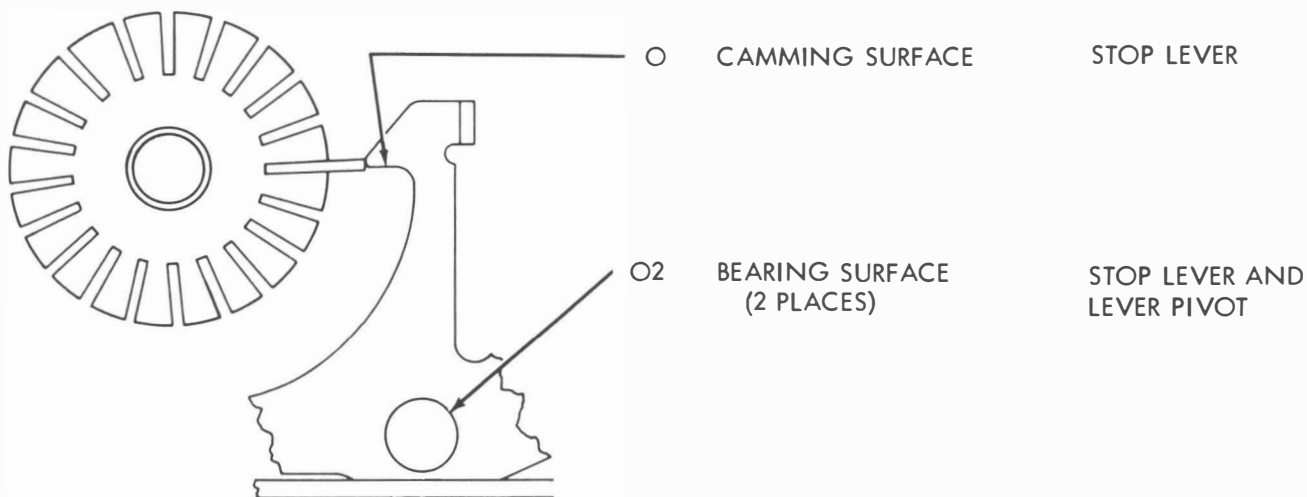

2.32 Answerback: Sensing Levers

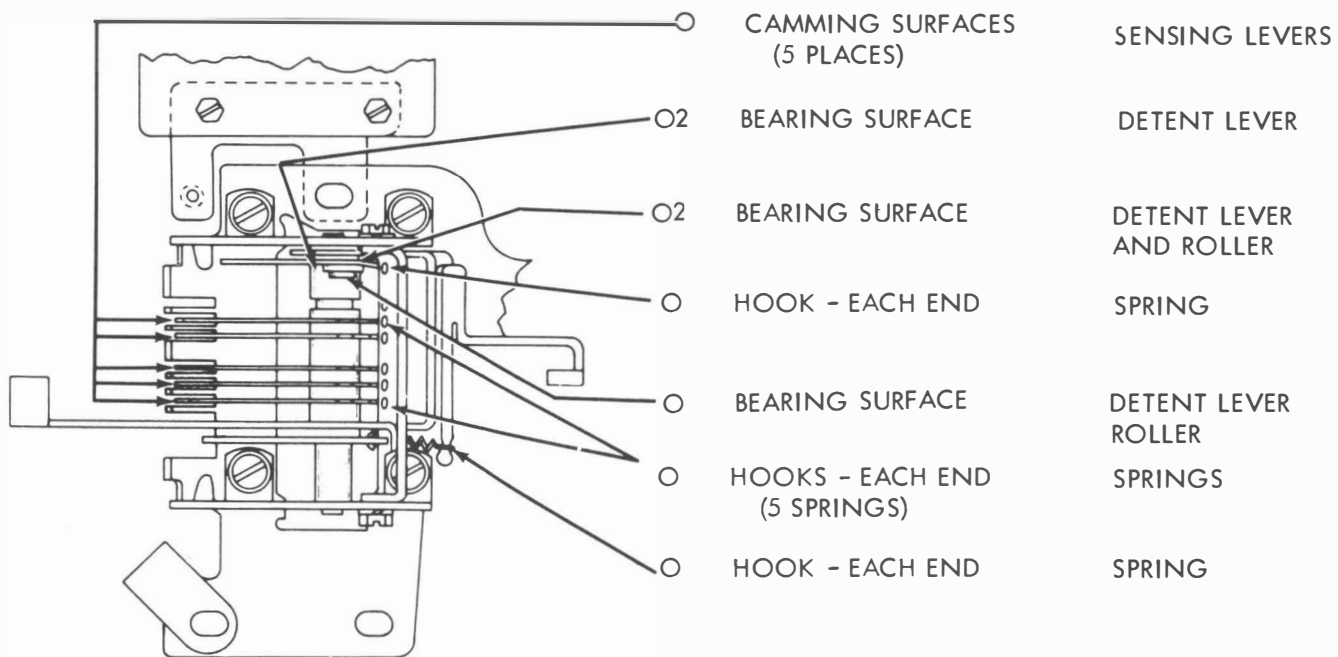

2.33 Answerback: Codebars and Sensing Levers

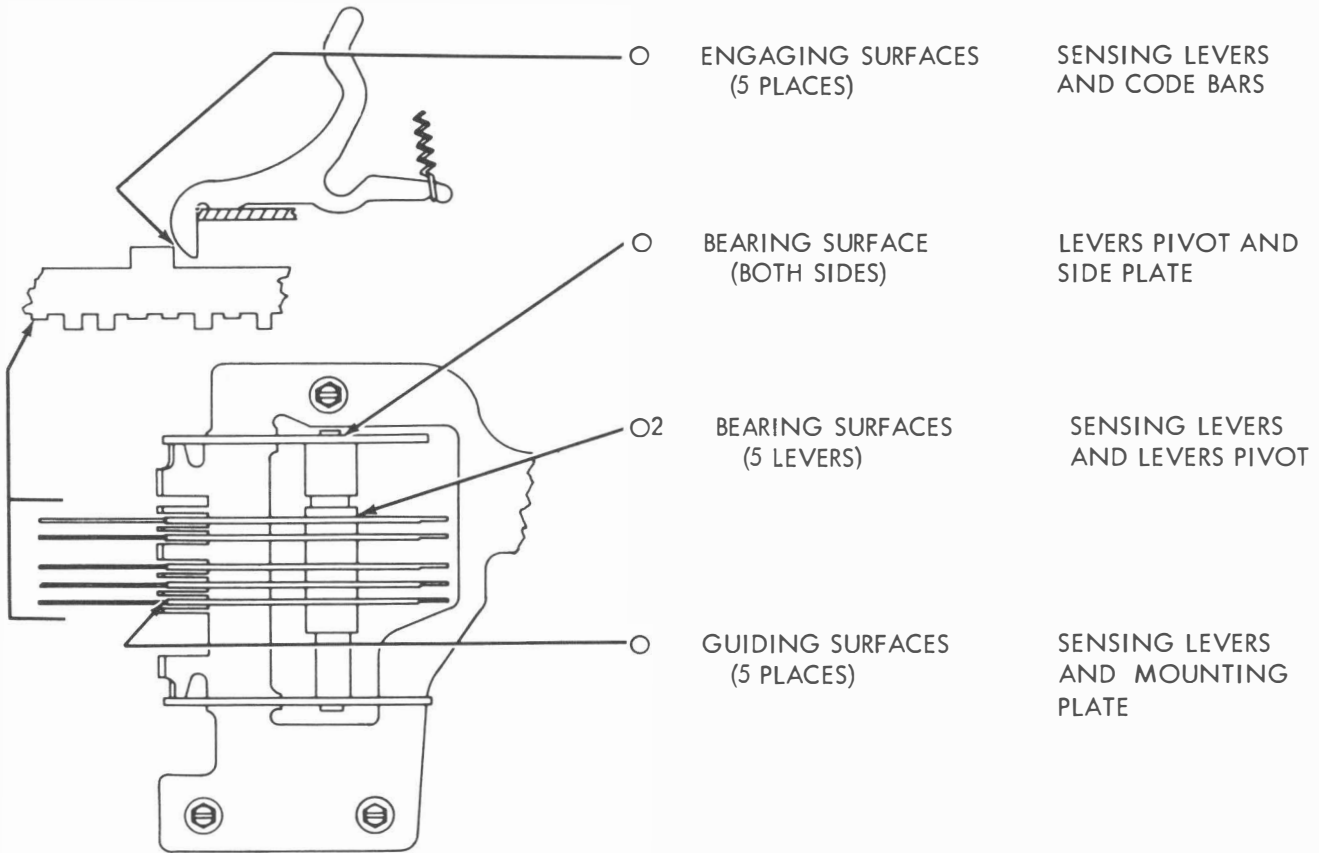

2.34 Answerback: Driving Mechanism

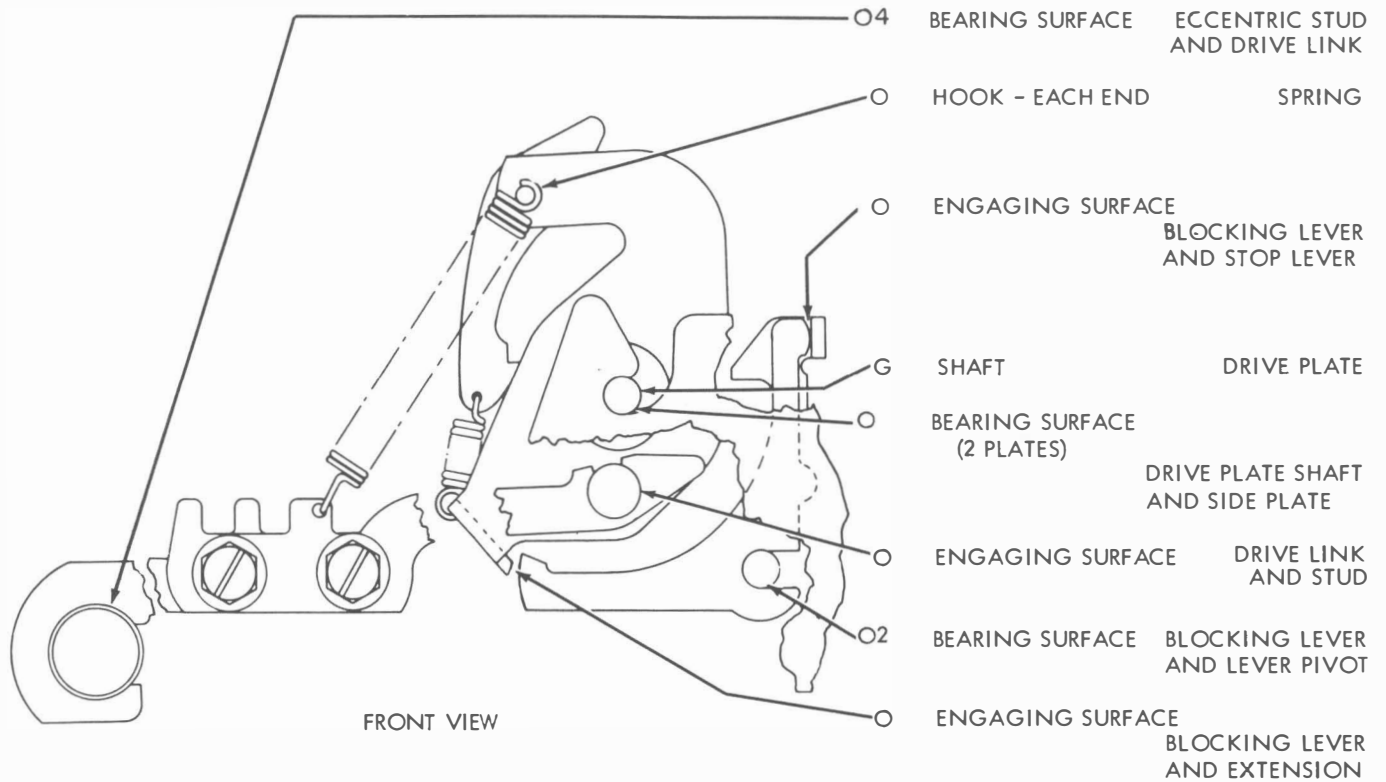

2.35 Answerback: Stepping Pawl

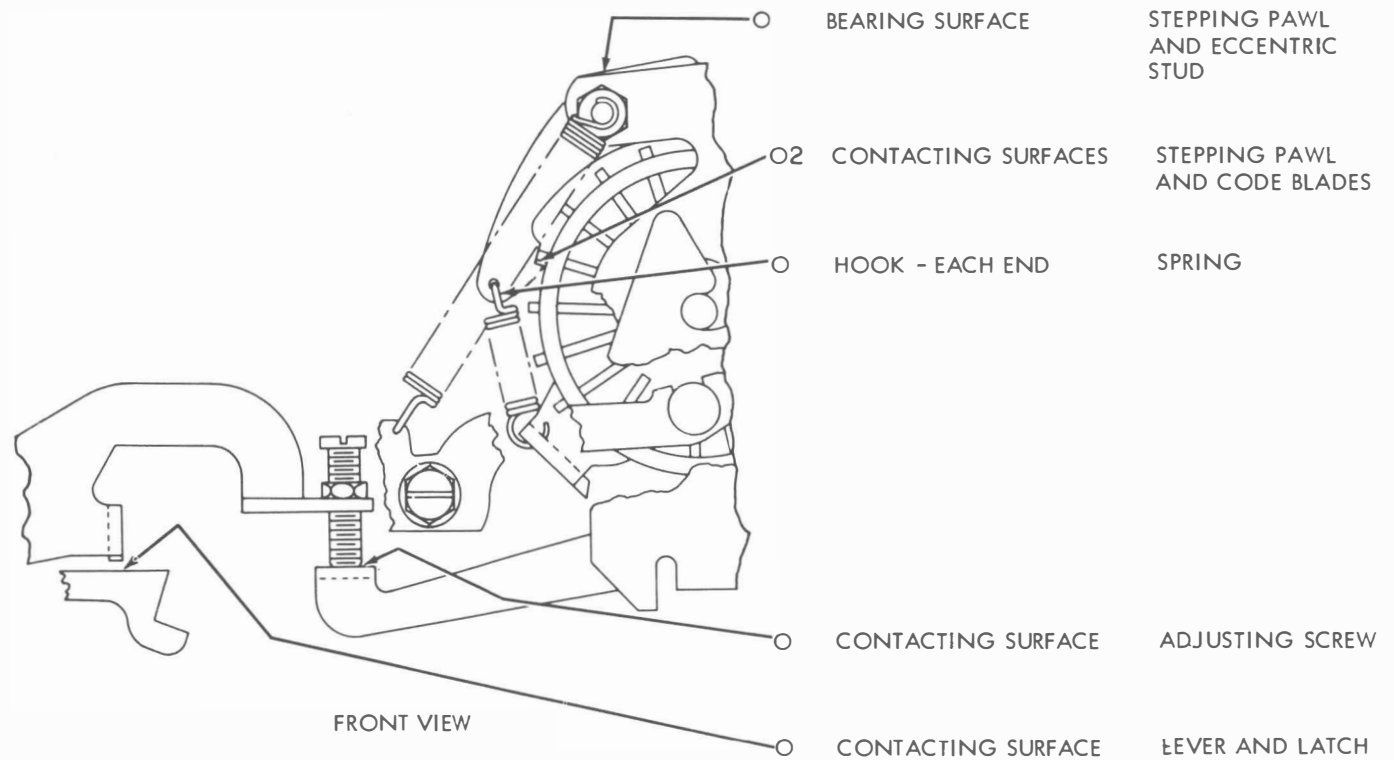

2.36 Blinding (Pulsing) Contacts and Repeat-space Mechanism

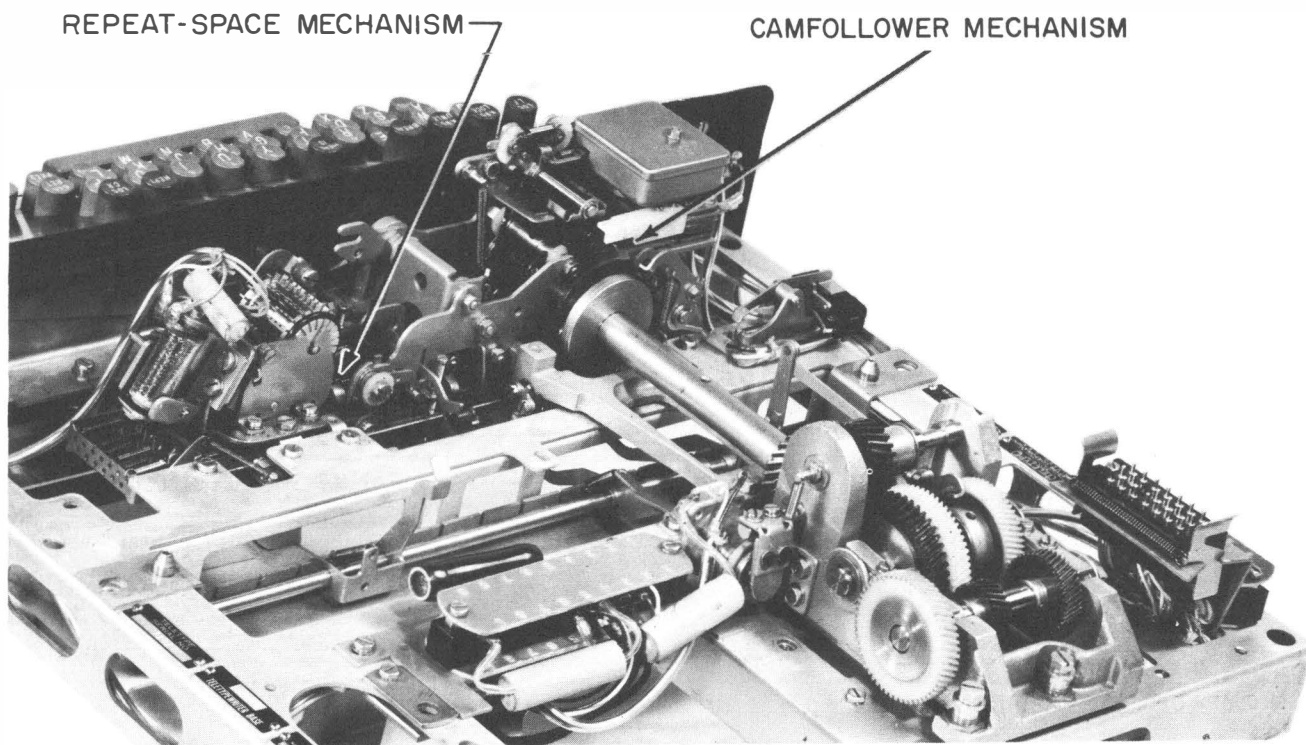

2.37 Blinding (Pulsing) Contacts – Camfollower Mechanism

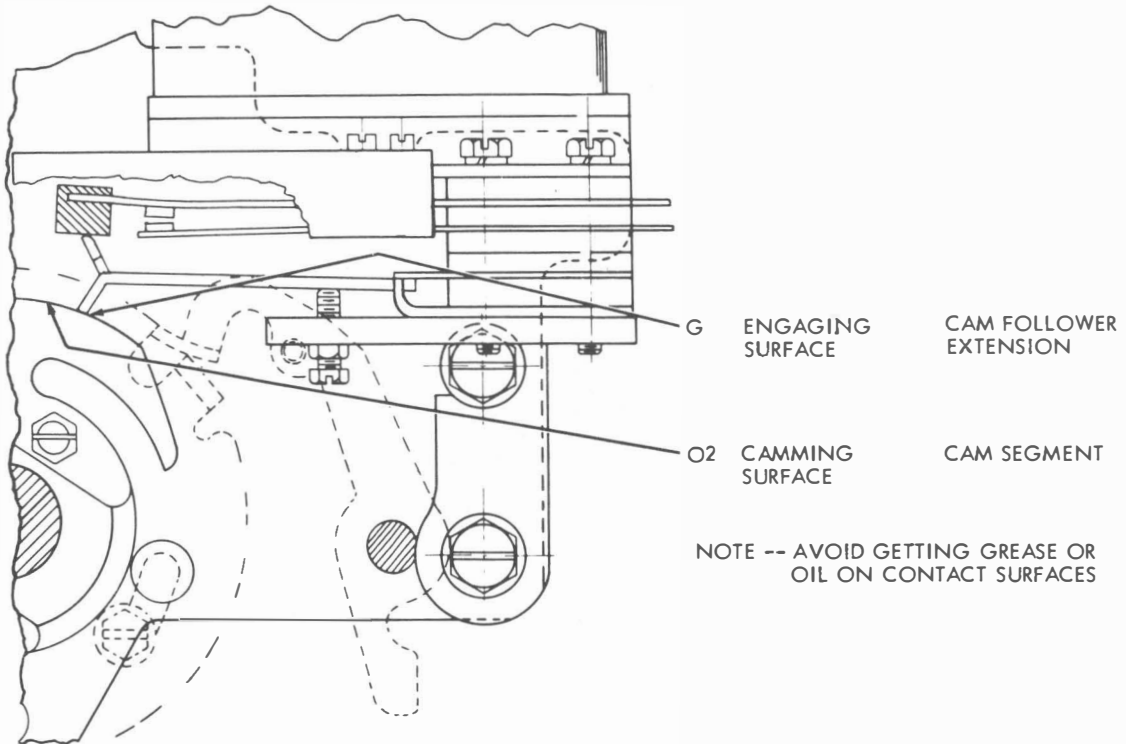

2.38 Repeat-space Mechanism

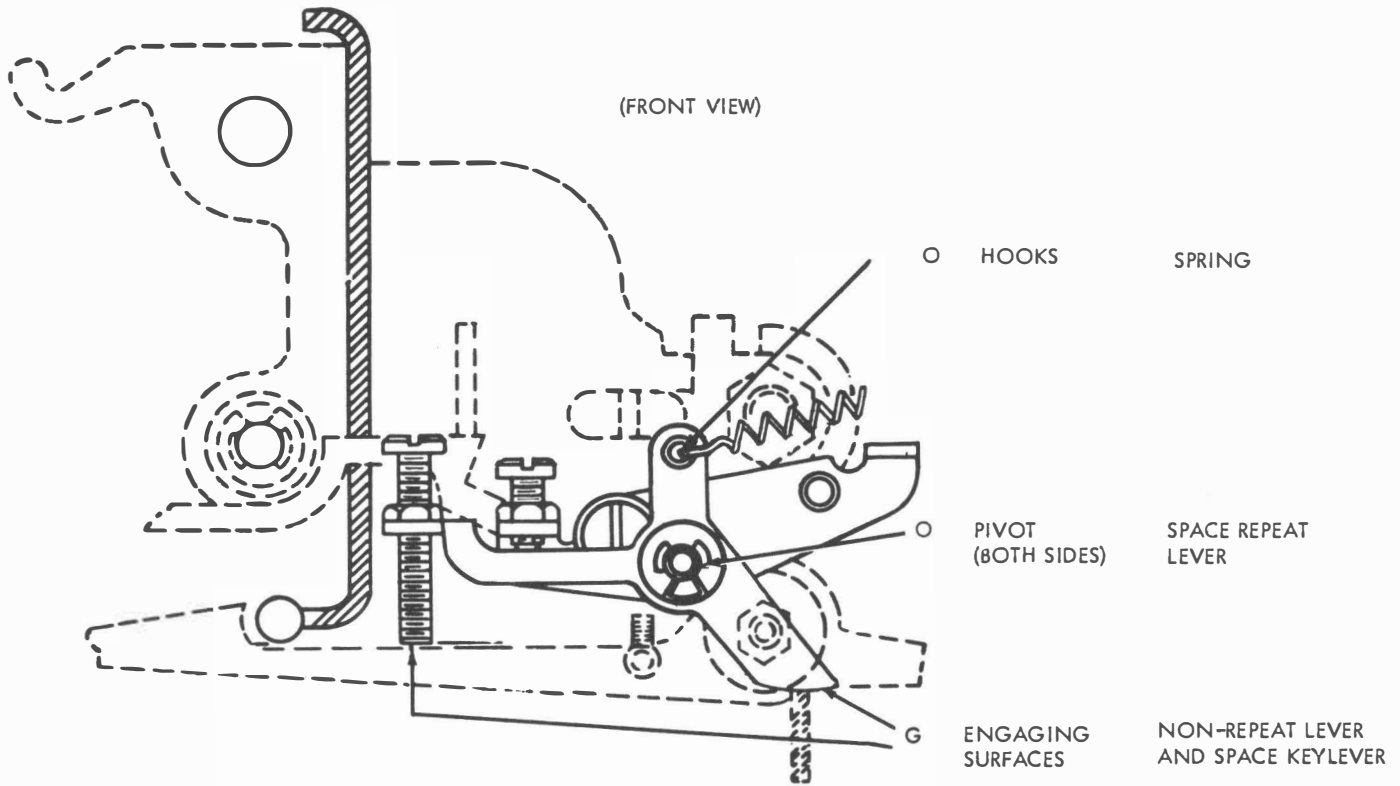

2.39 Electrical Send-Receive Break Mechanism (Not Shown on a Locator Photograph)

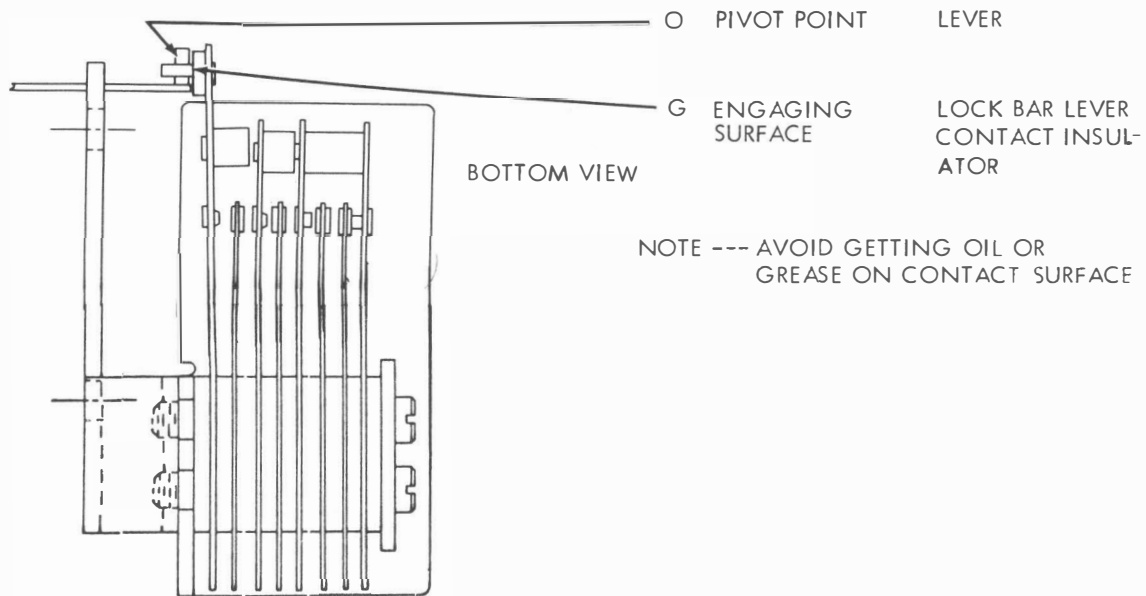

2.40 Remote Control Gear Shift (Rear View)

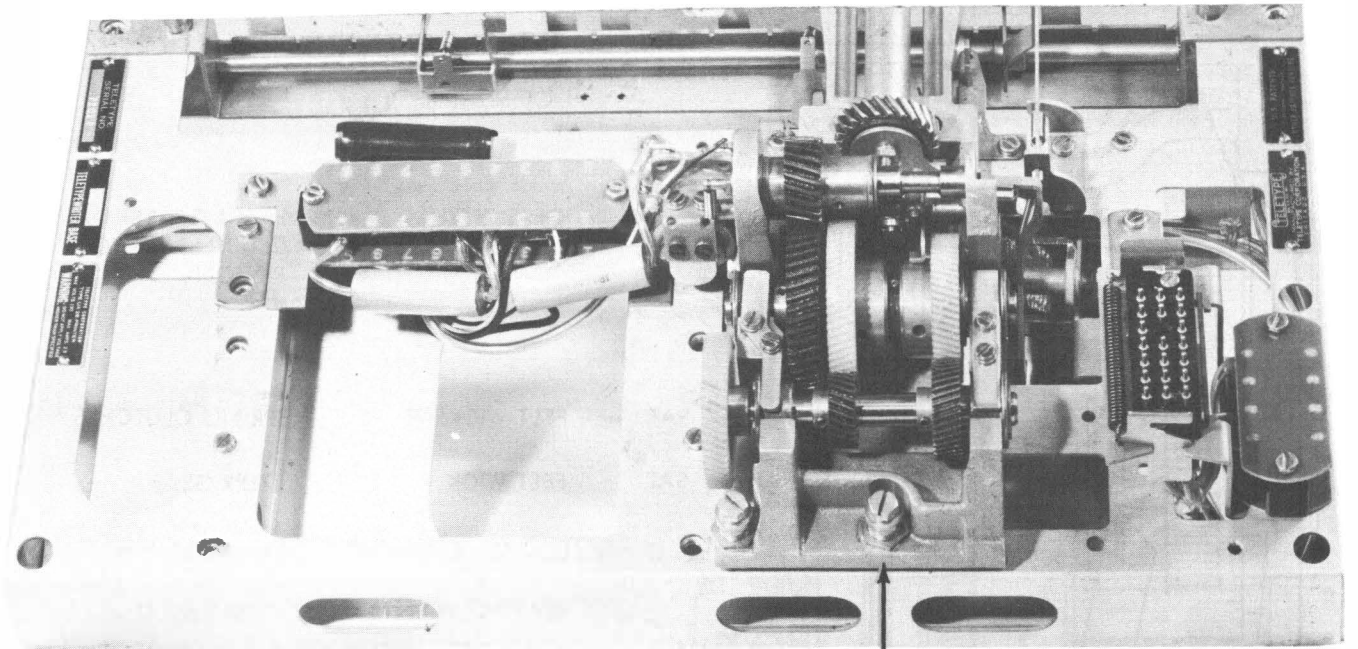

REMOTE CONTROL GEAR SHIFT

2.41 Remote Control Gear Shift (Top Front View)

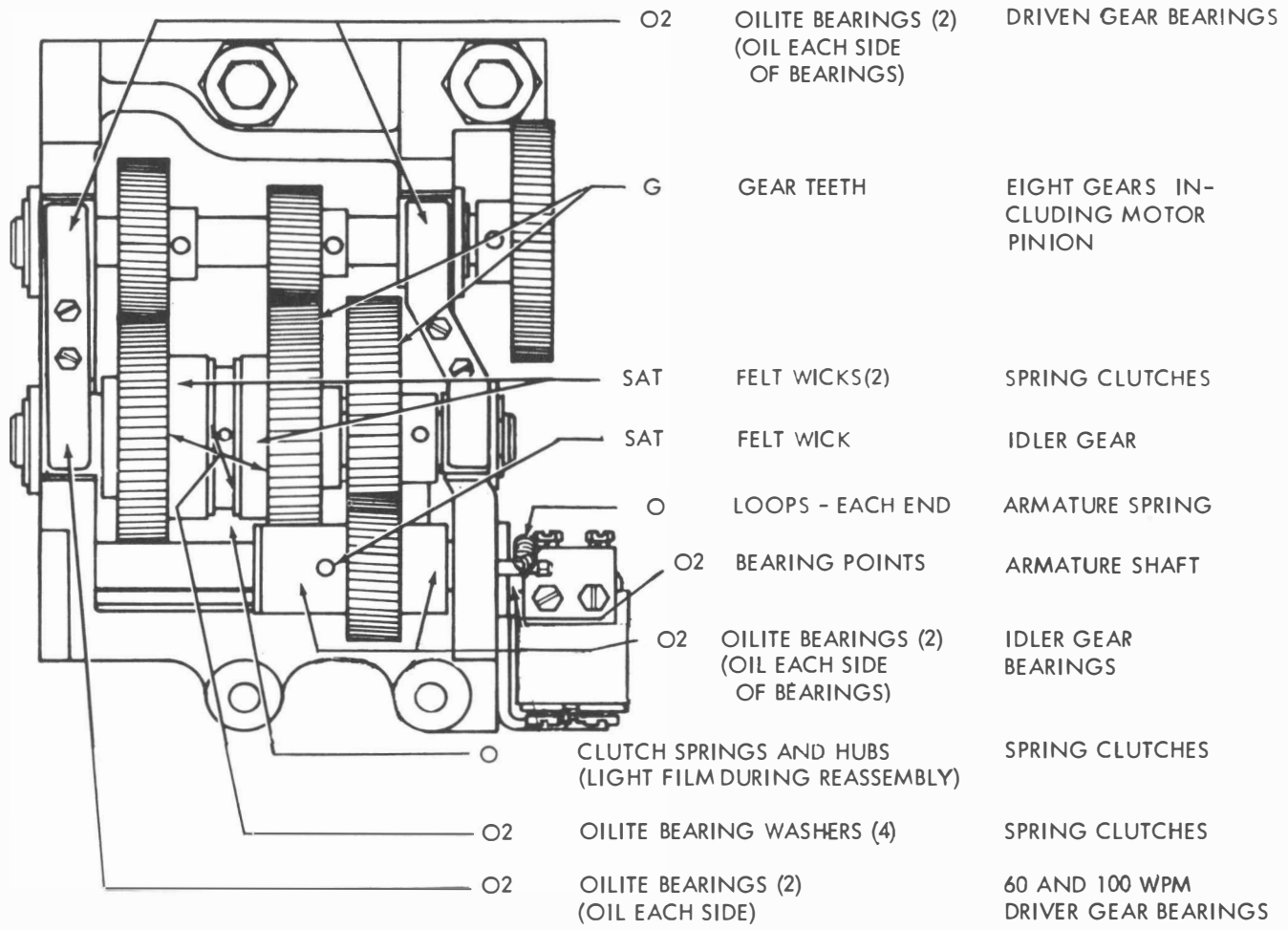

2.42 Form Feedout

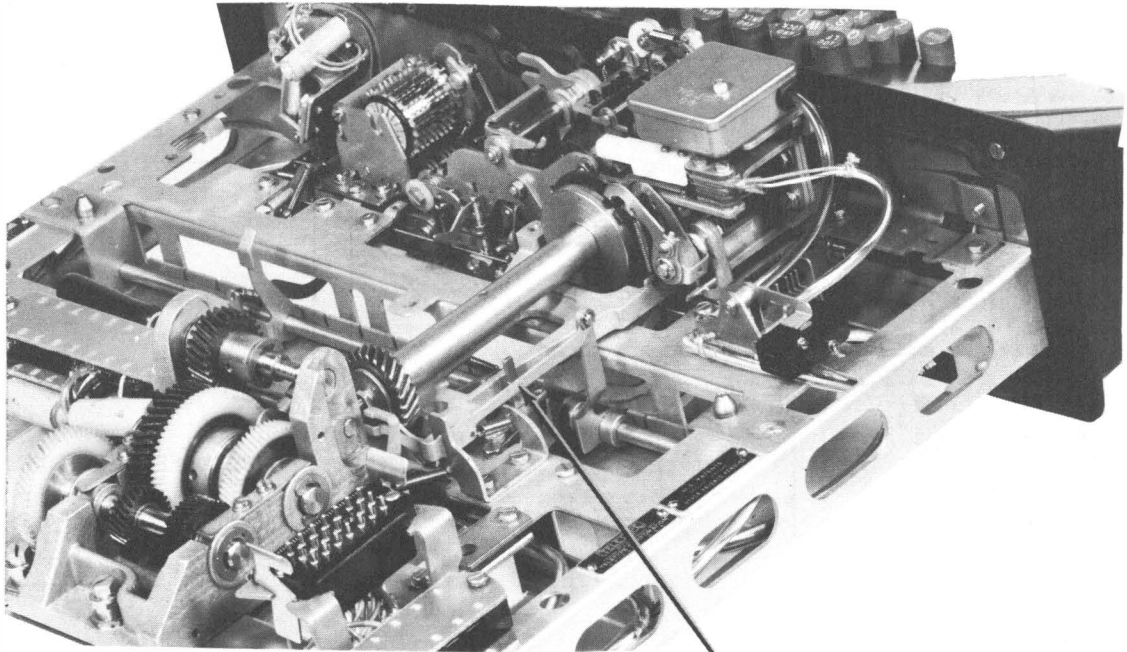

FORM FEEDOUT

2.43 Form Feedout

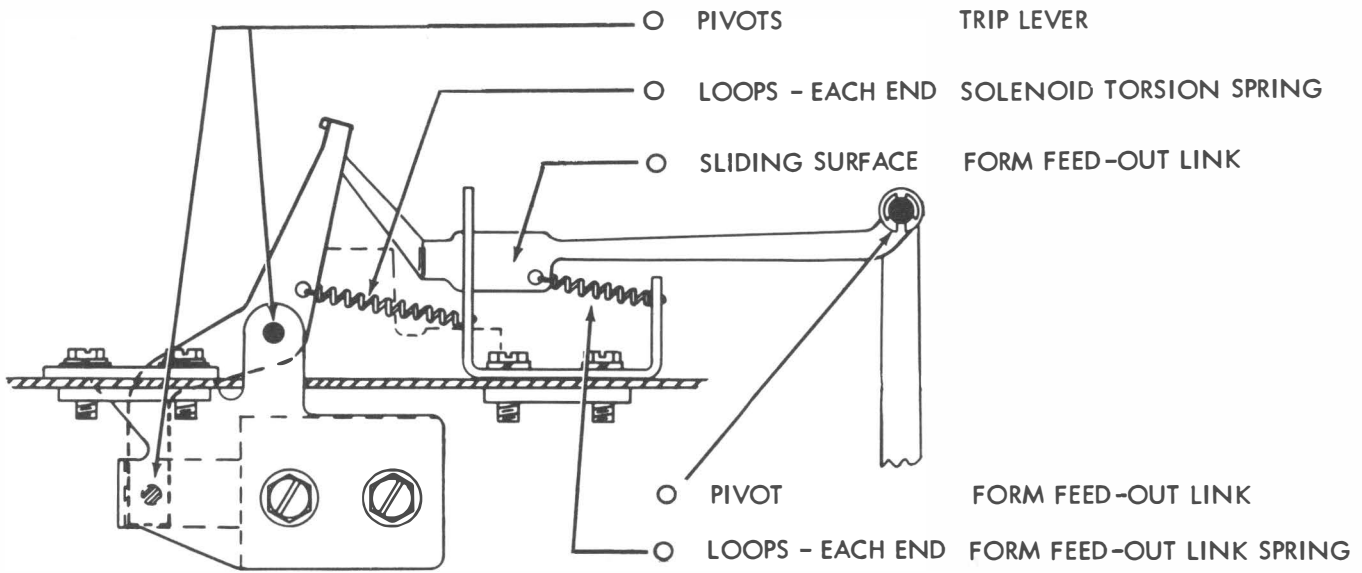

2.44 Variable Speed Drive — Speed Selecting Mechanism

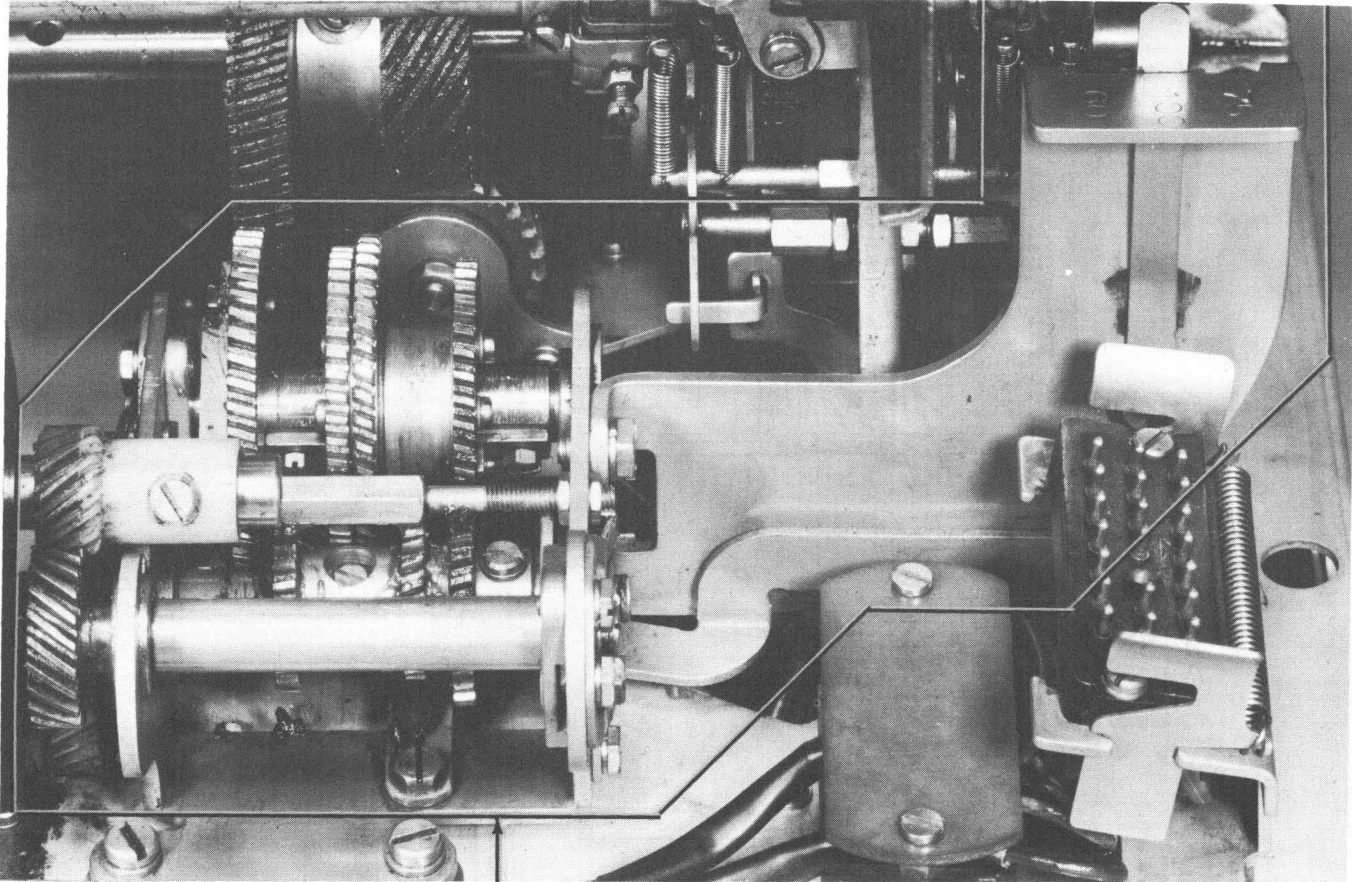

SPEED SELECTING MECHANISM

2.45 Variable Speed Drive — Speed Selecting Mechanism

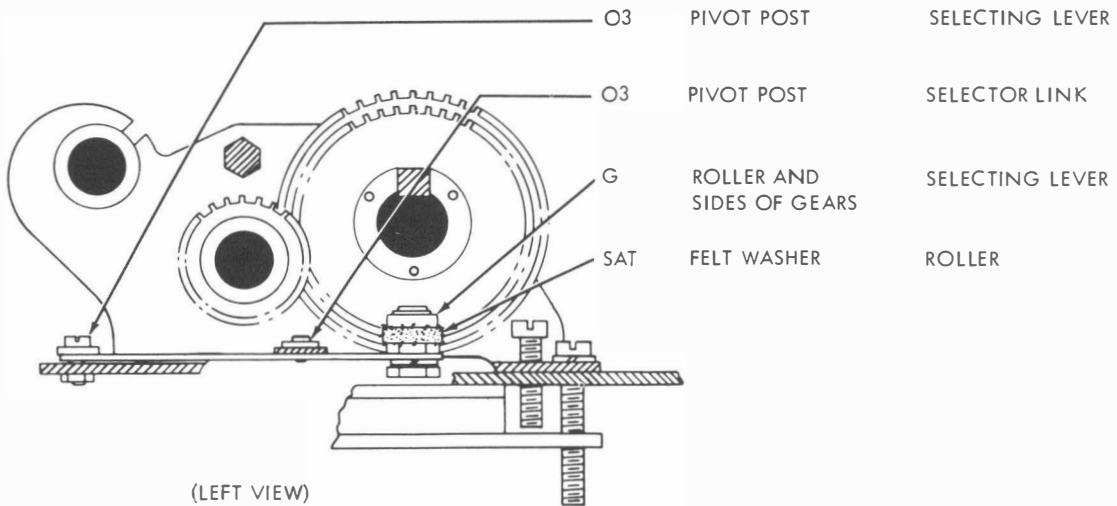
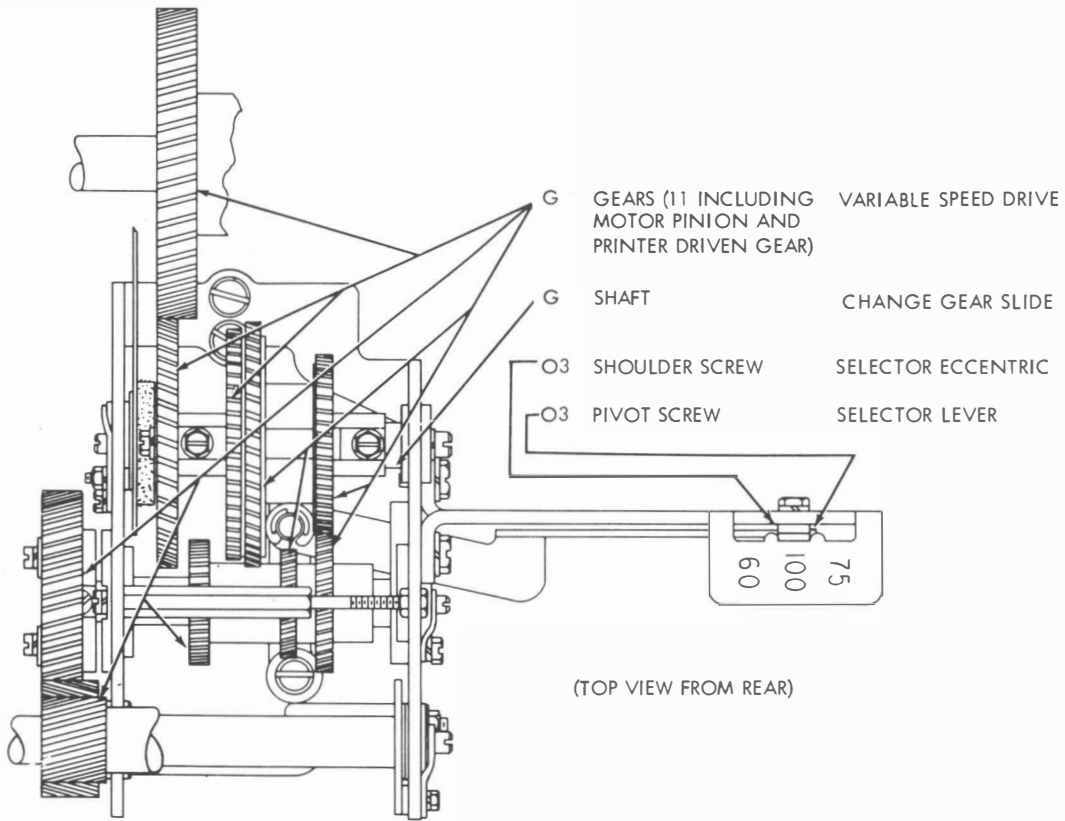

2.46 Universal Keyboard Switch (Not Shown on a Locator Photograph)

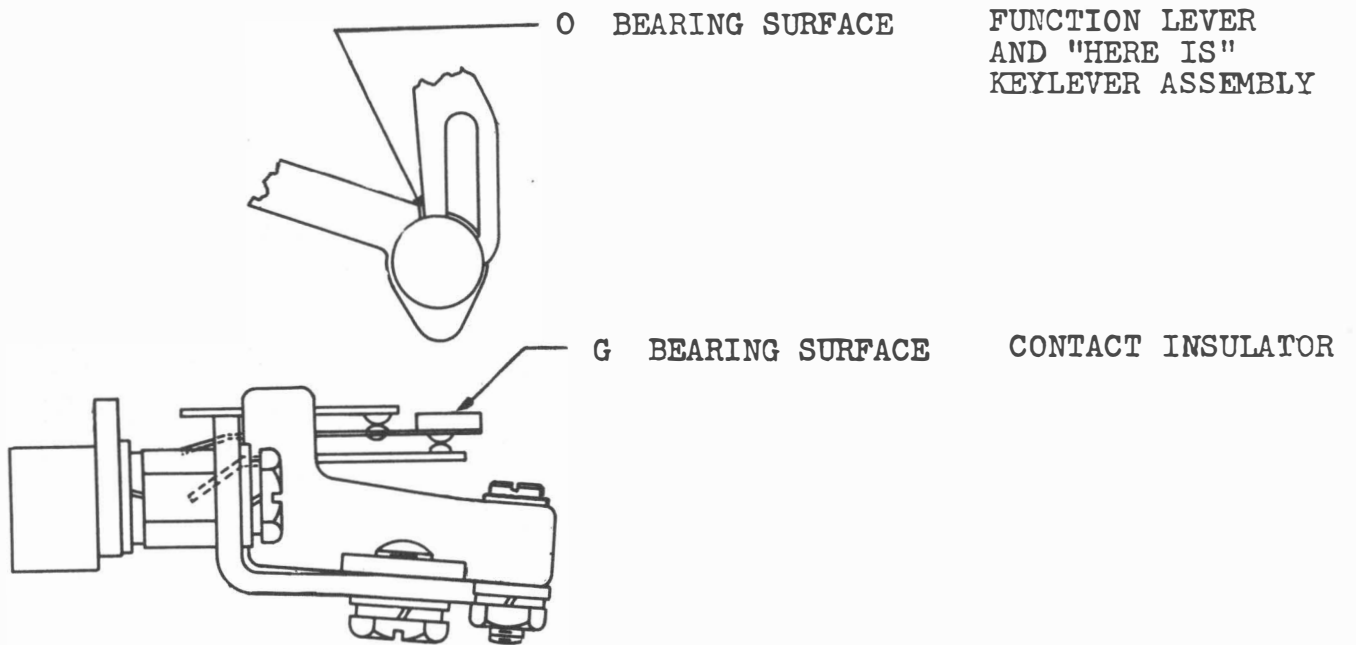

3. EARLIER DESIGN KSR BASE (KEYBOARD)

3.01 Codelever, Local Carriage Return, Local Line Feed and Keyboard Lock Mechanisms

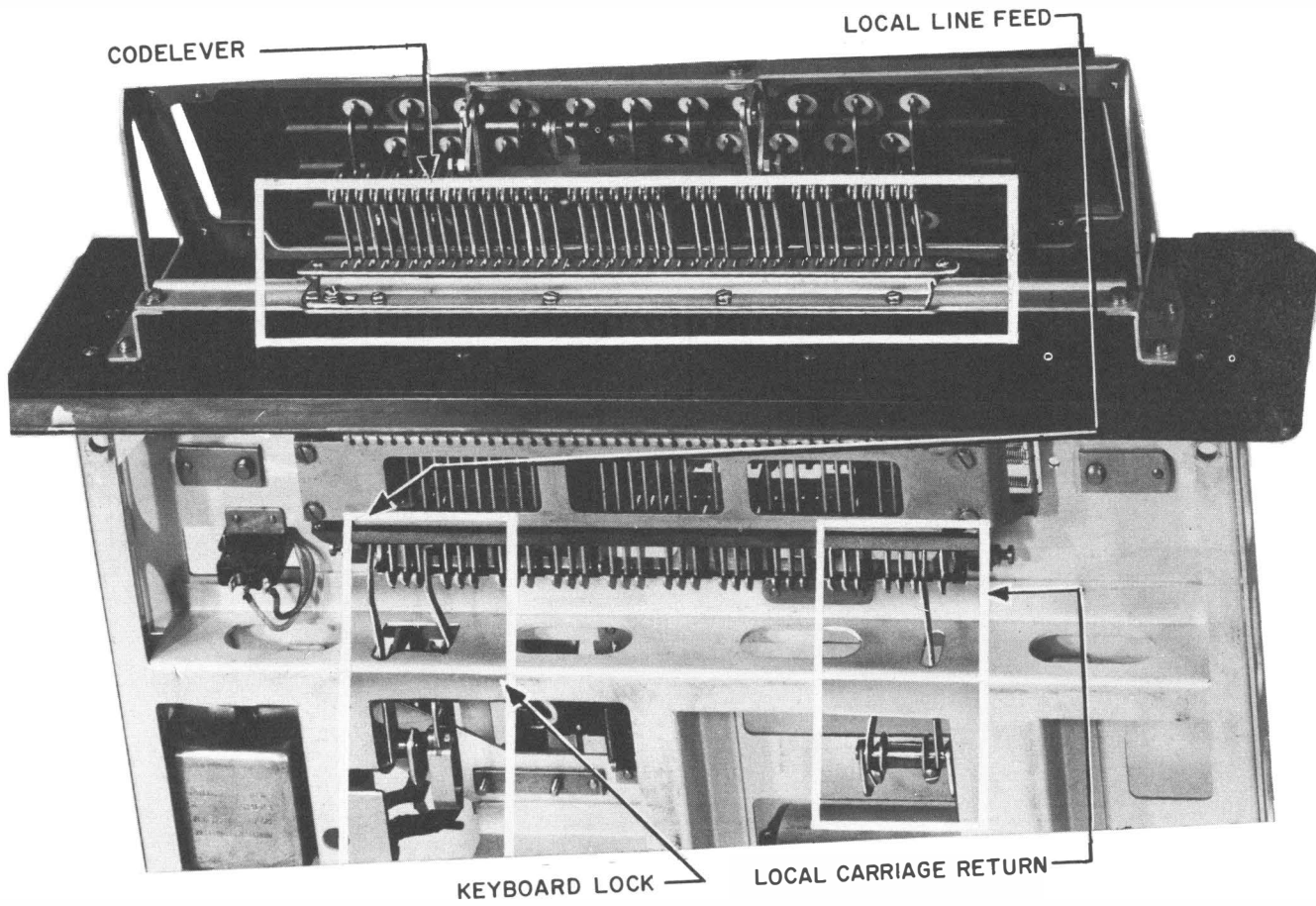

3.02 Codelever

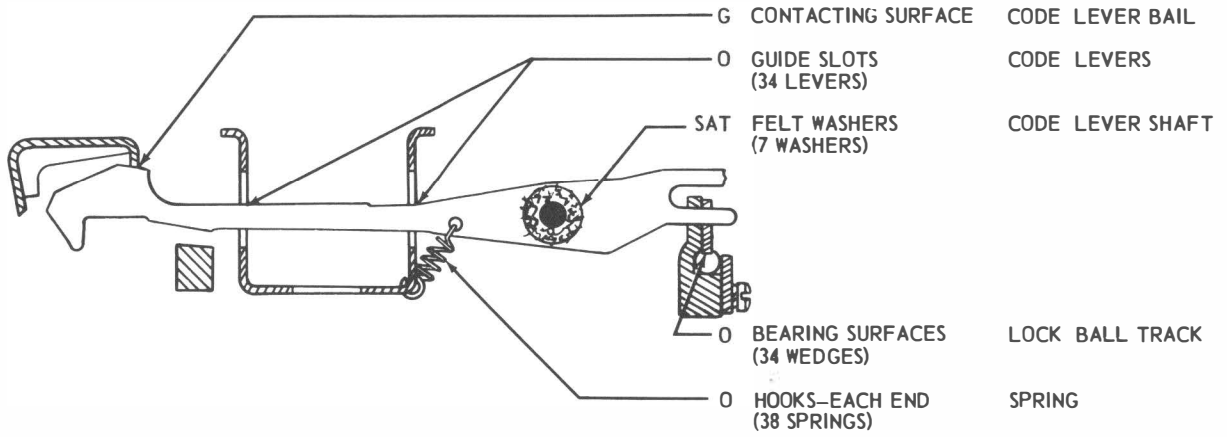

3.03 Local Carriage Return

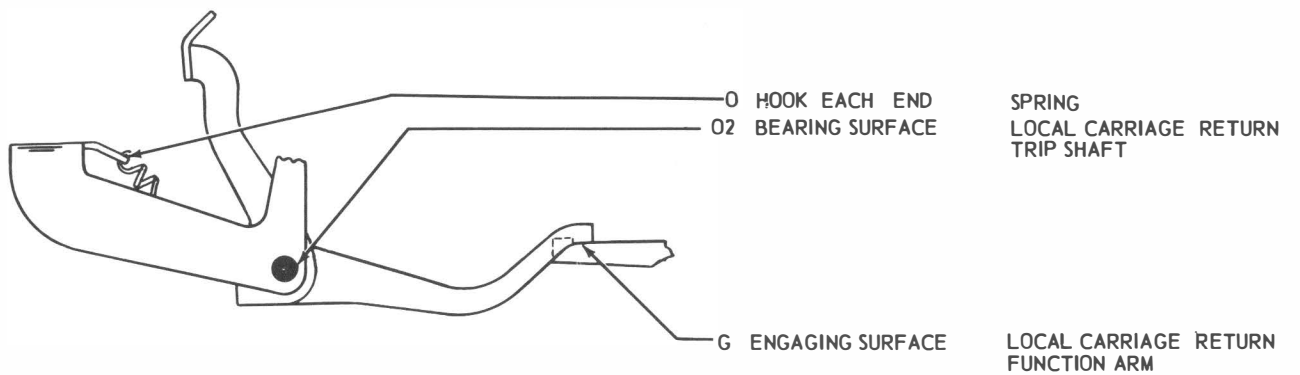

3.04 Local Line Feed

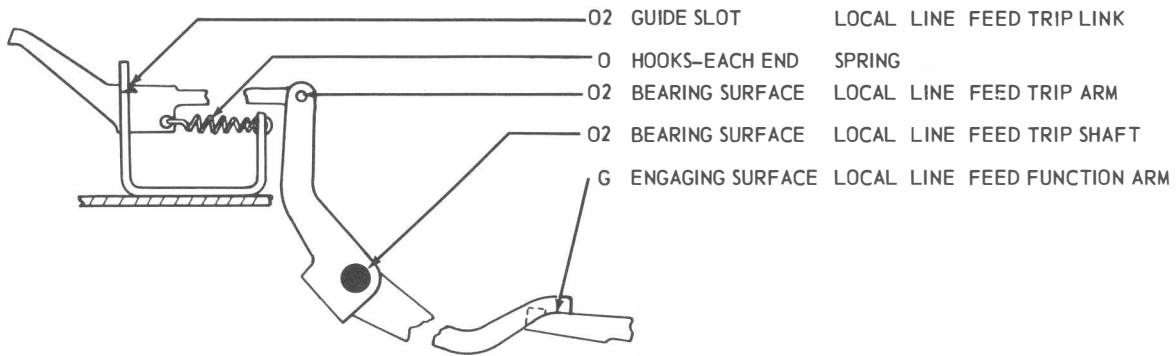

3.05 Keyboard Lock

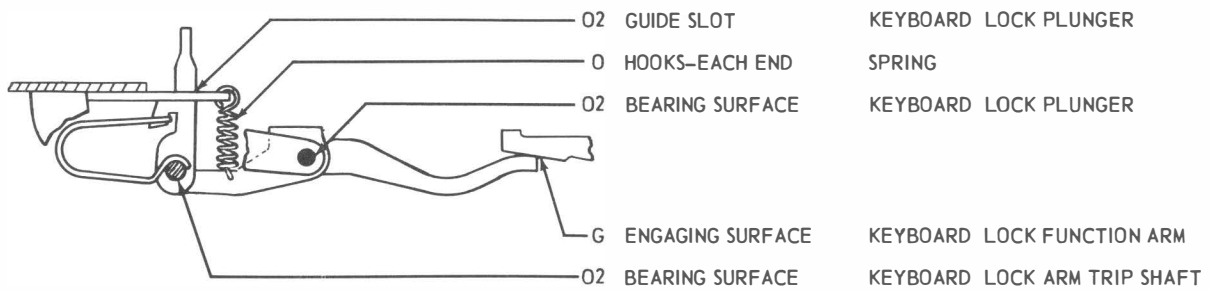

3.06 Margin Indicator, Contact Box, Codebar, Codebar Bail and Eccentric Follower, Codelever Bail, and Keyboard Selector Mechanisms

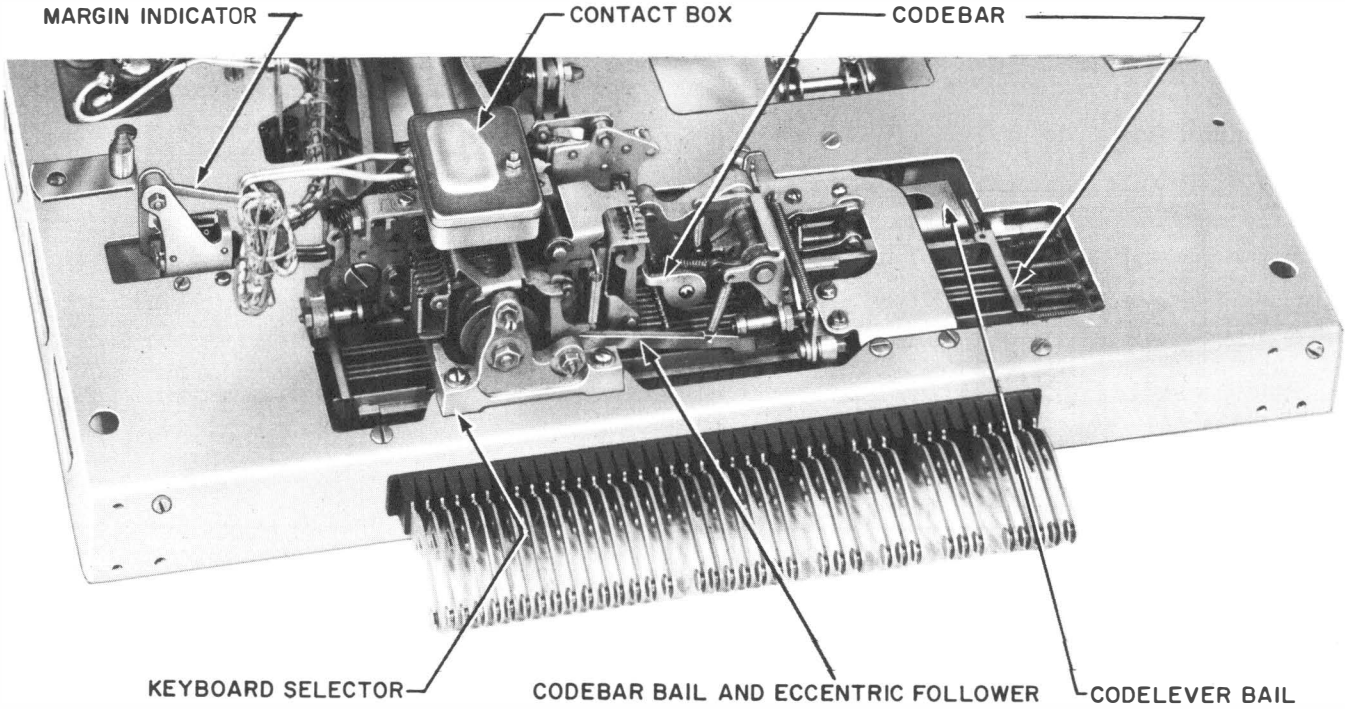

3.07 Margin Indicator (Rear View)

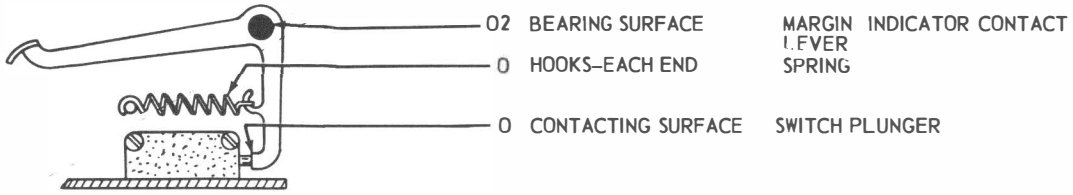

3.08 Contact Box

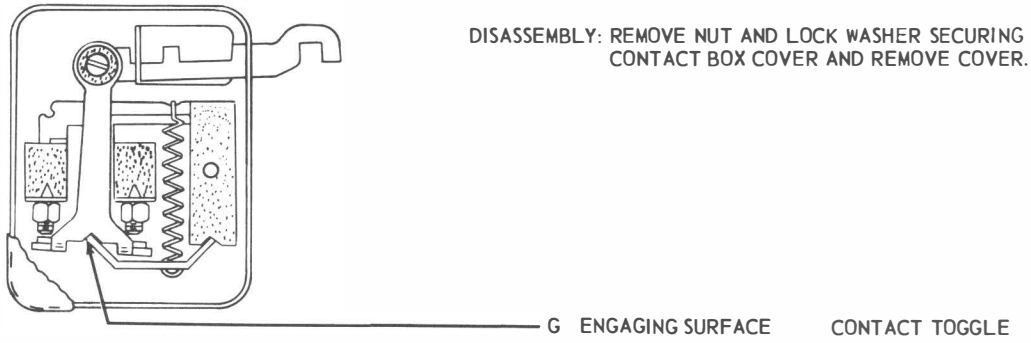

3.09 Codebar

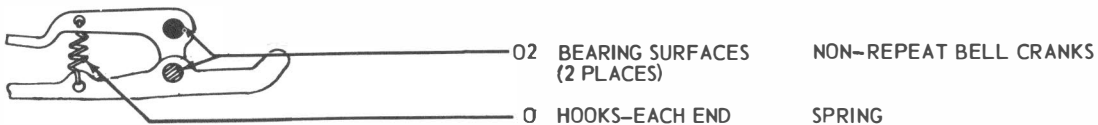
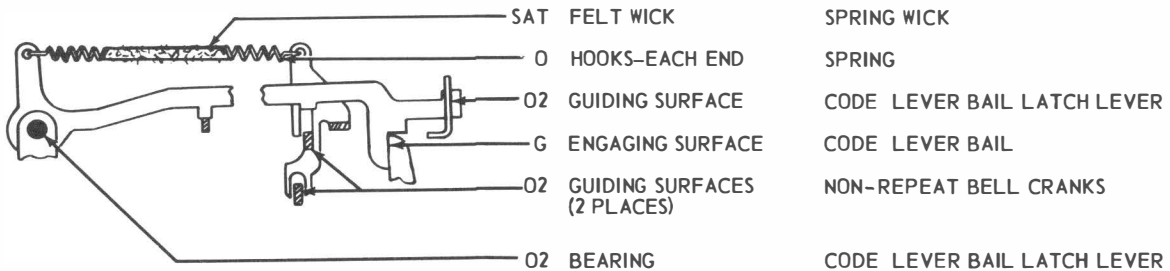
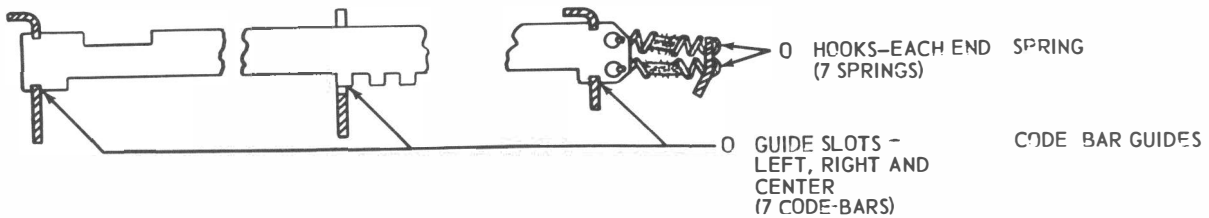

3.10 Keyboard Selector

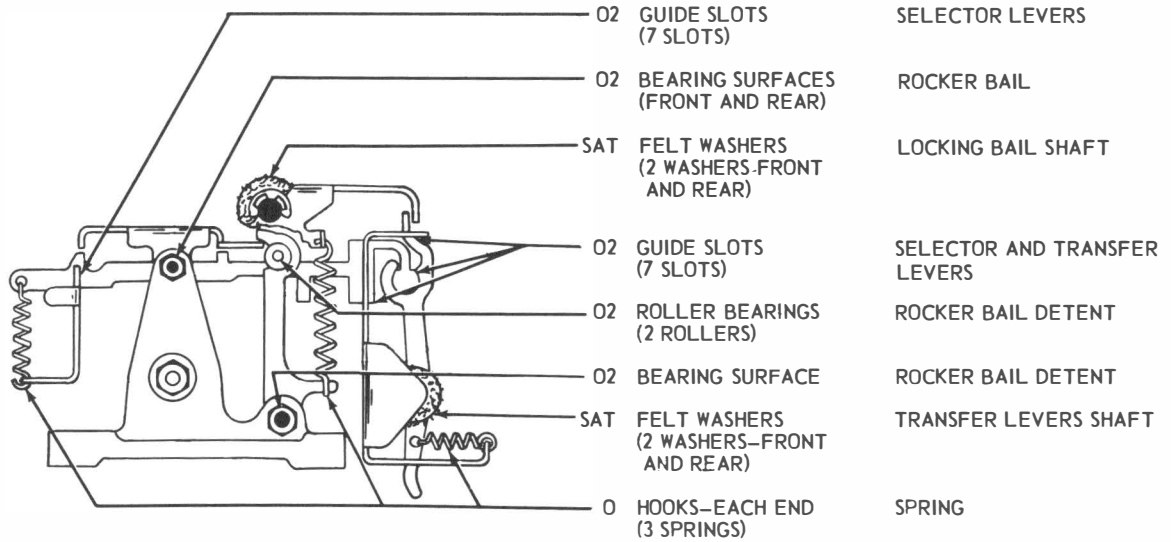

3.11 Codebar Bail and Eccentric Follower

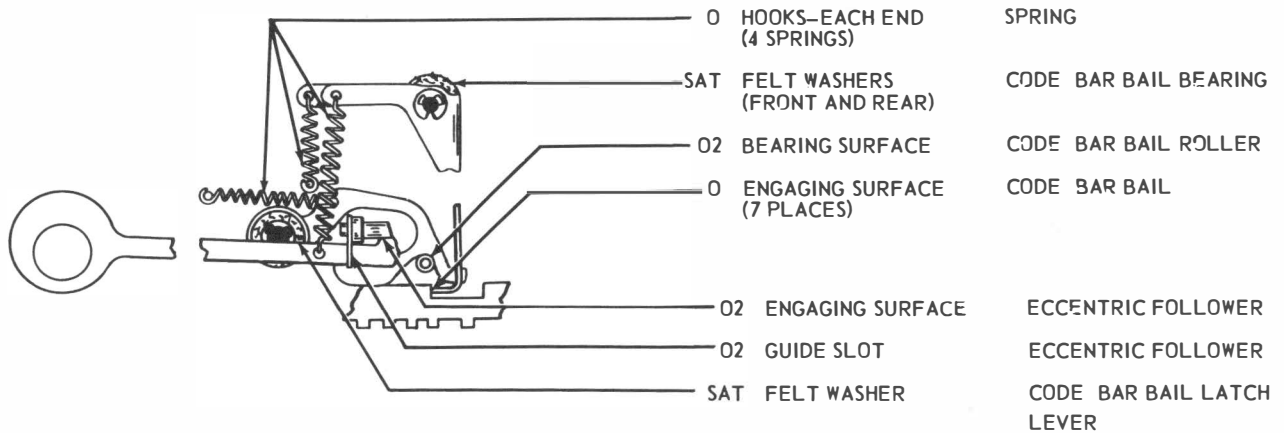

3.12 Codelever Bail

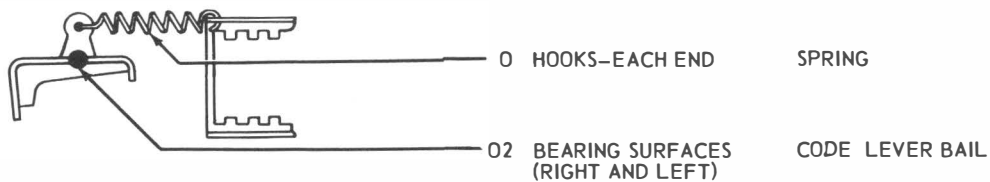

3.13 Intermediate Gears and Shaft

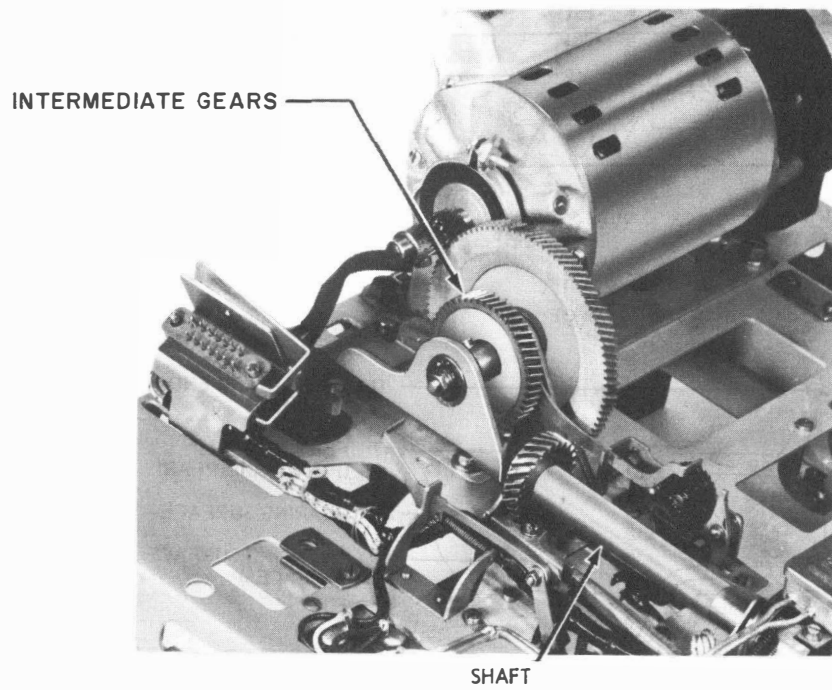

3.14 Intermediate Gears (For motor, see section entitled Motor Unit, Lubrication)

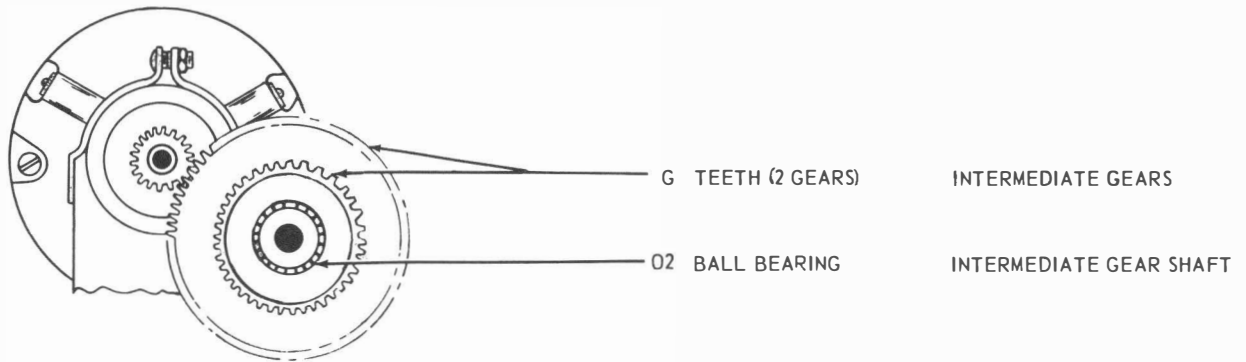

3.15 Shaft

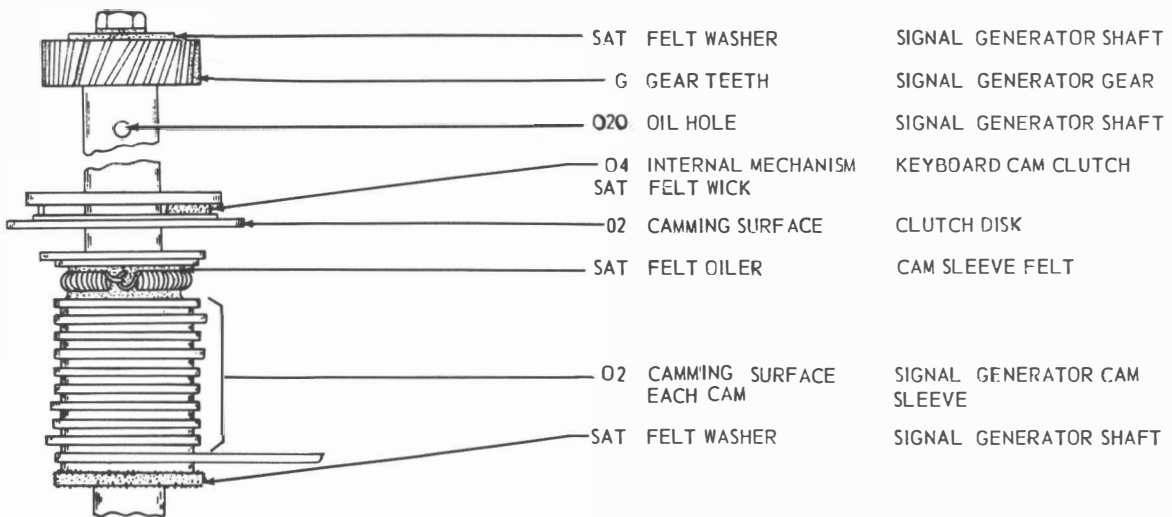

3.16 Signal Generator, Signal Generator Clutch, Intermediate Lever, and Time Delay Mechanisms
(Rear View)

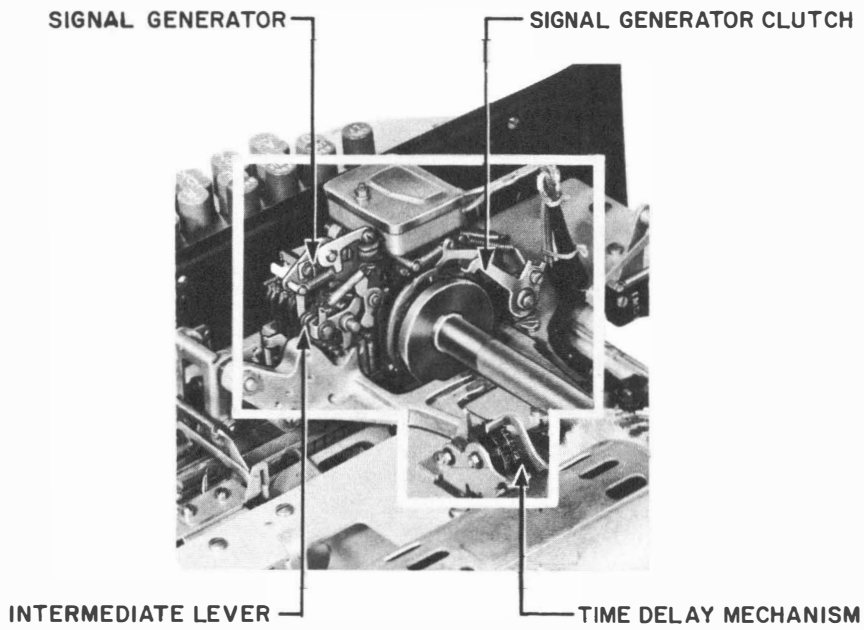

3.17 Time Delay Mechanism

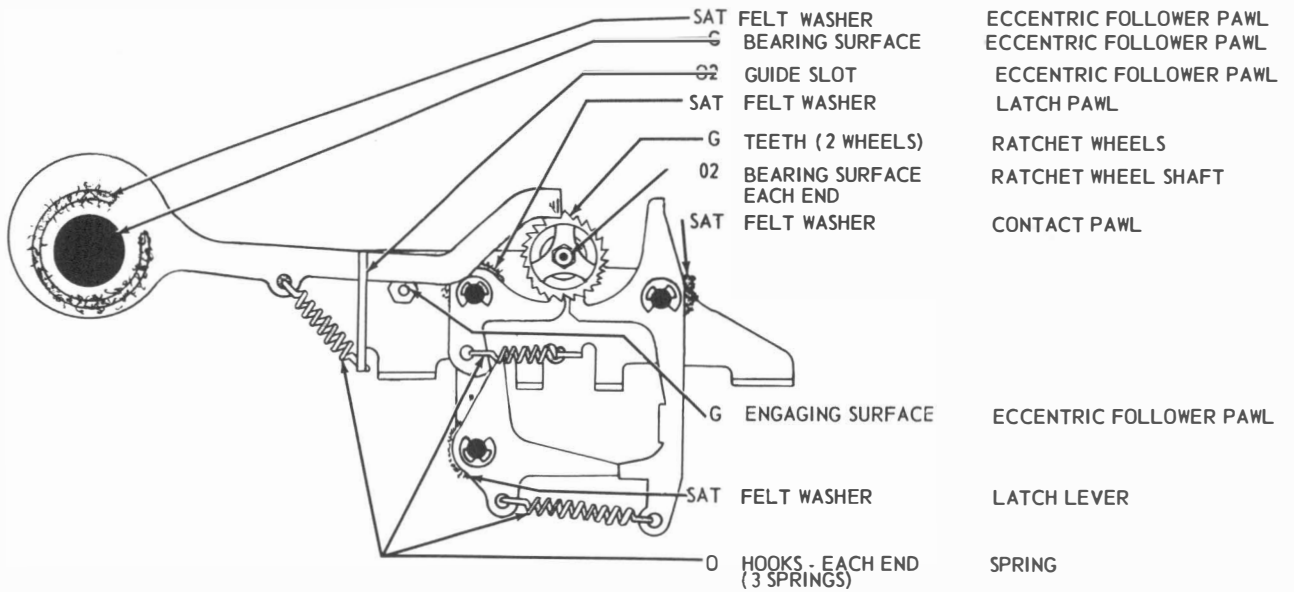

3.18 Signal Generator

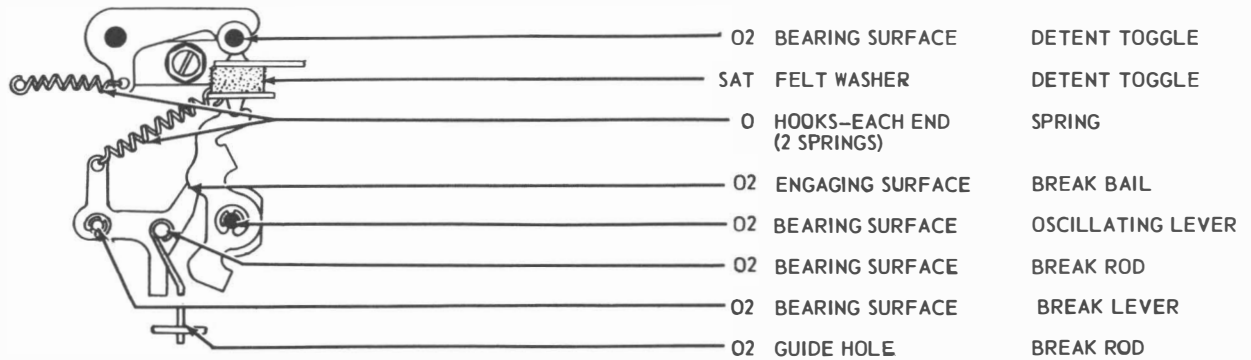

3.19 Signal Generator Clutch

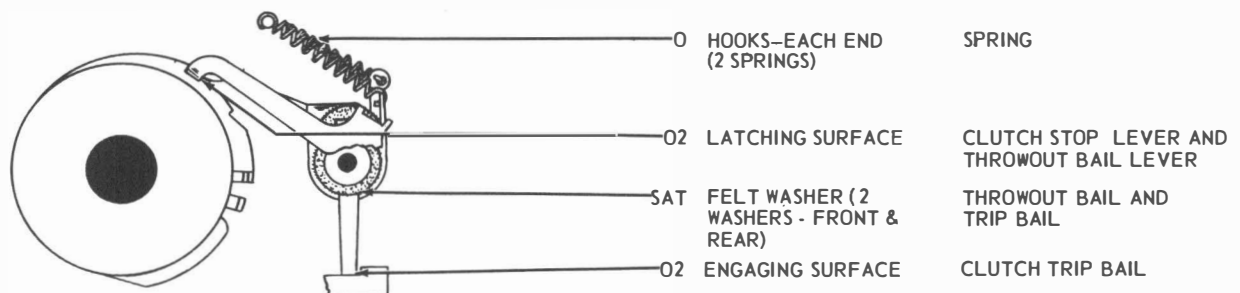

3.20 Intermediate Lever (Signal Generator)

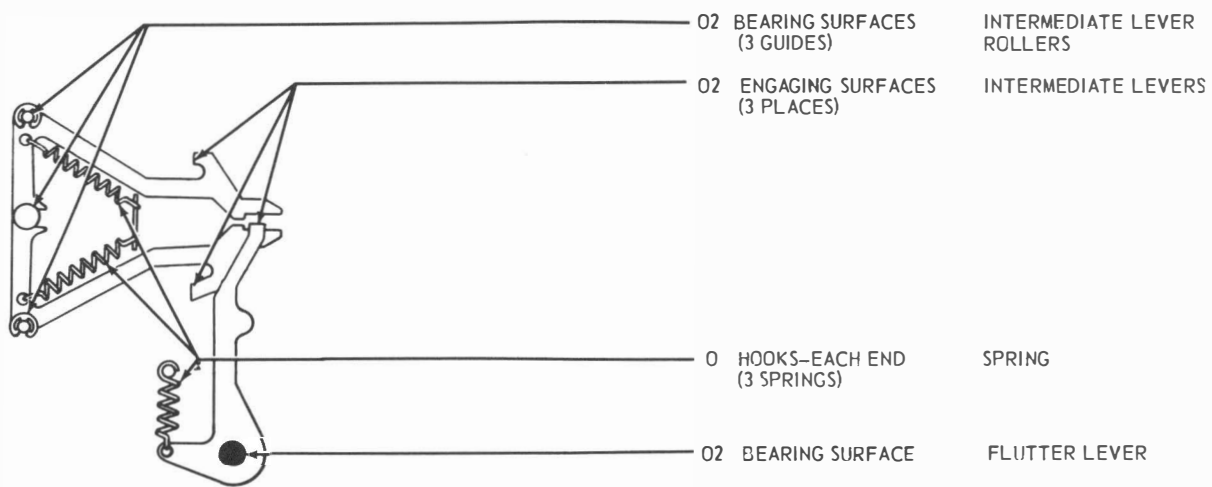

3.21 Signal Line Break and Repeat-space Mechanisms (Rear View)

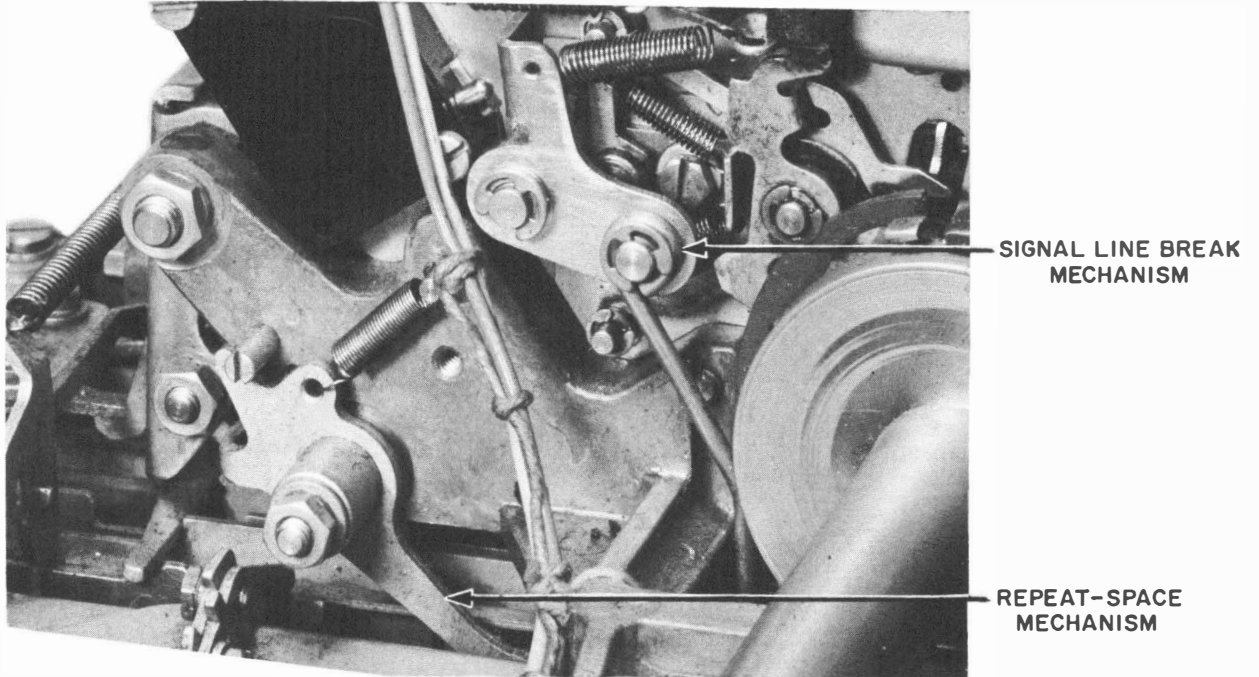

3.22 Signal Line Break Mechanism

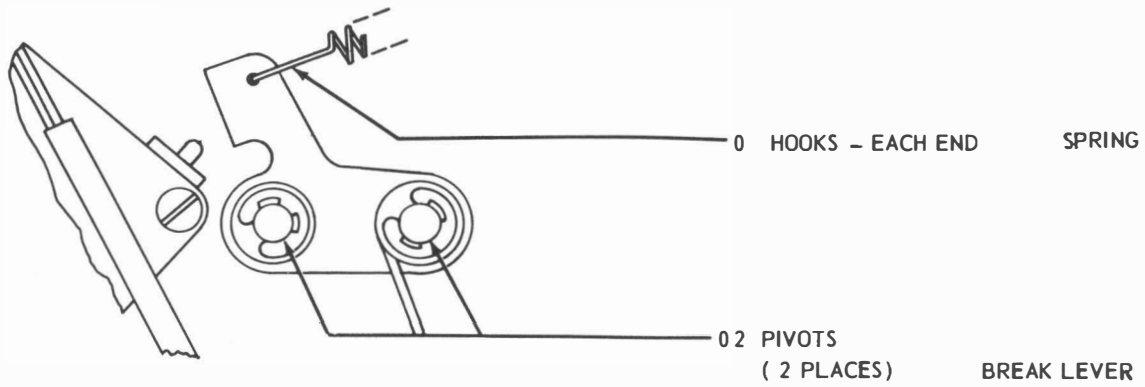

3.23 Repeat-space Mechanism

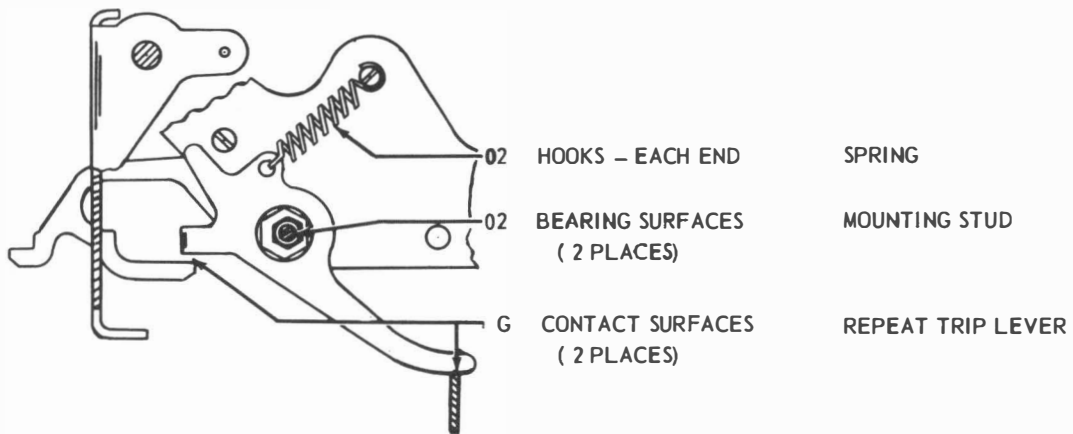

3.24 Paper Feedout

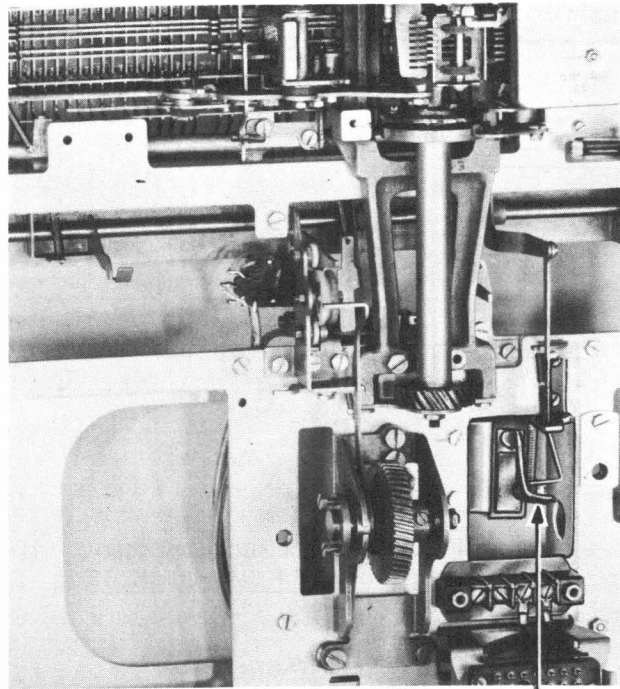

PAPER FEEDOUT

3.25 Paper Feedout

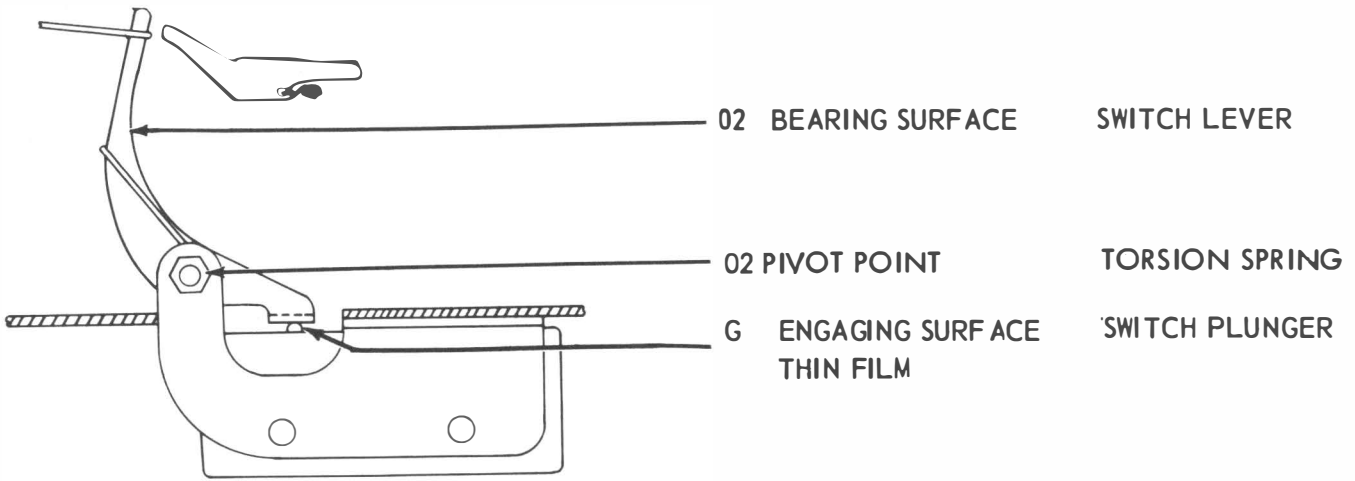

3.26 Answerback: Blinding (Pulsing) Contacts (Not Shown on a Locator Photograph)

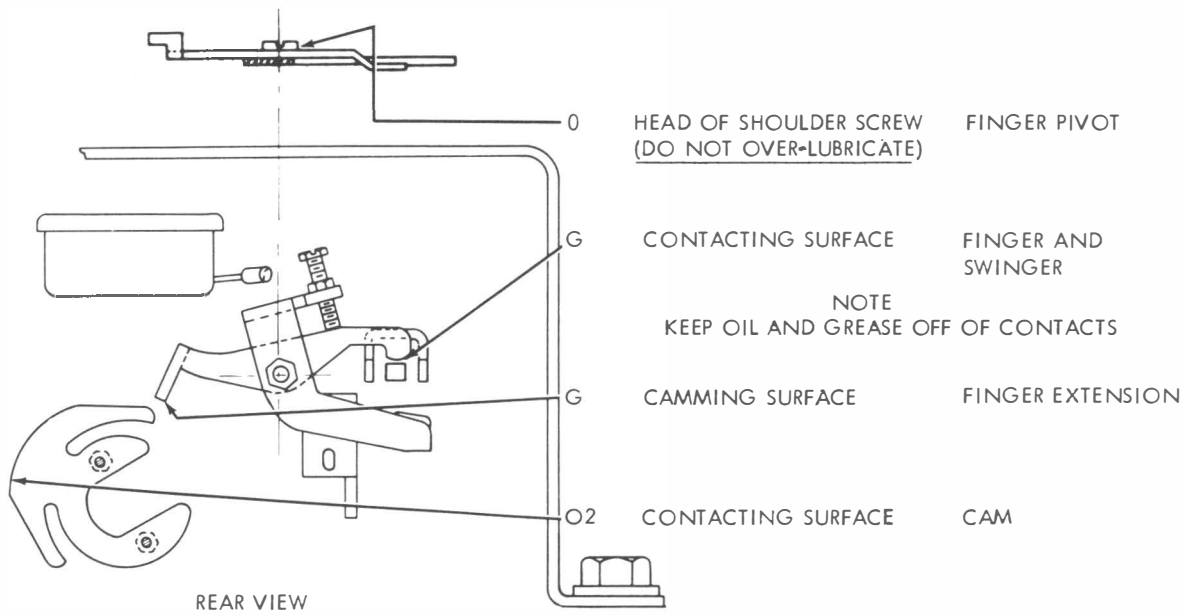

3.27 Answerback: Driving Mechanism (Not Shown on a Locator Photograph)

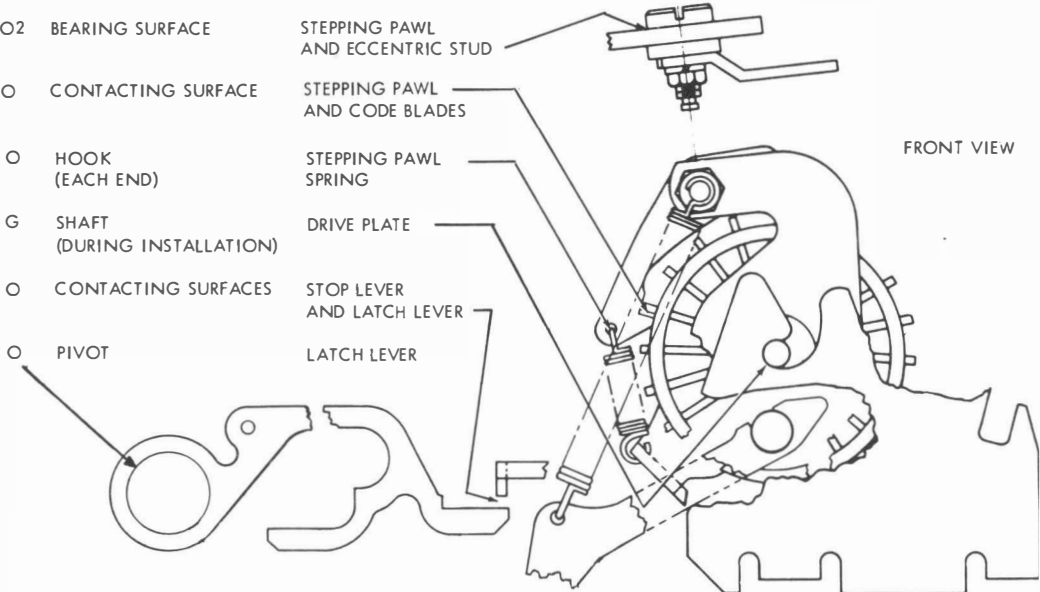
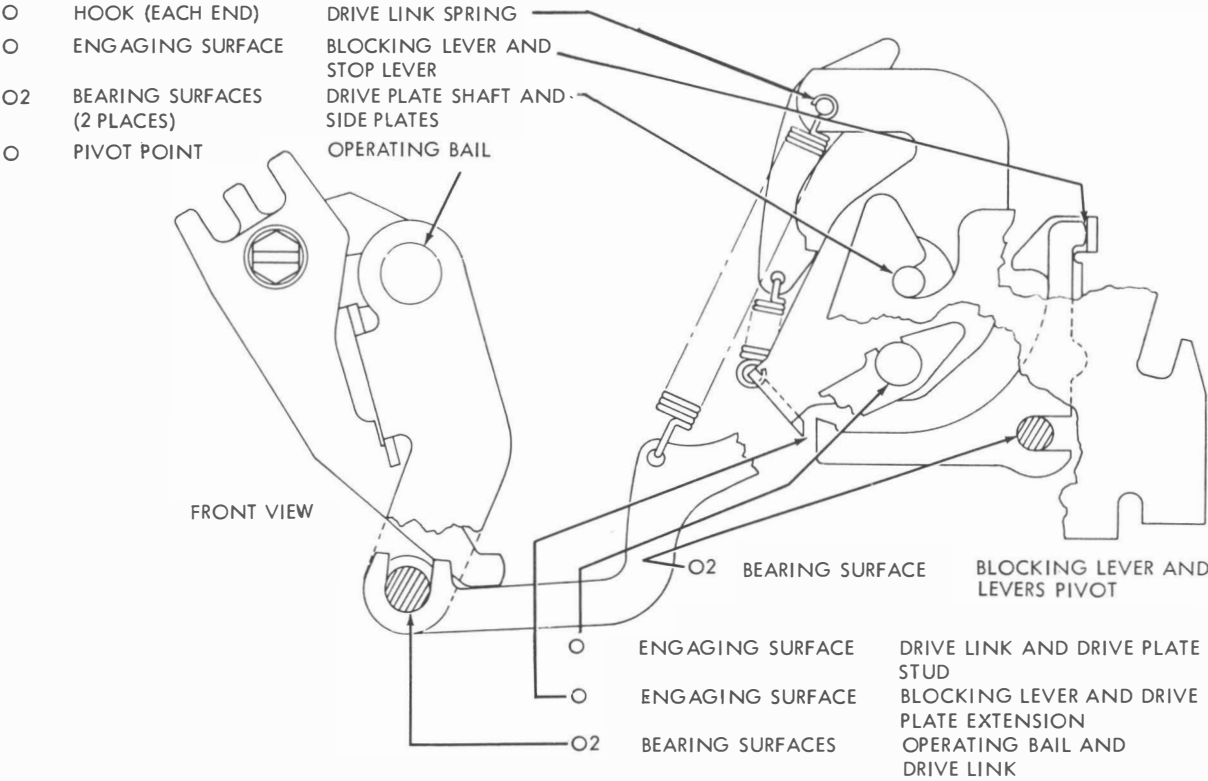

Note: Also lubricate according to 2.30 through 2.32.

4. RECEIVING-ONLY (RO) BASE

4.01 Signal Line Break Mechanism

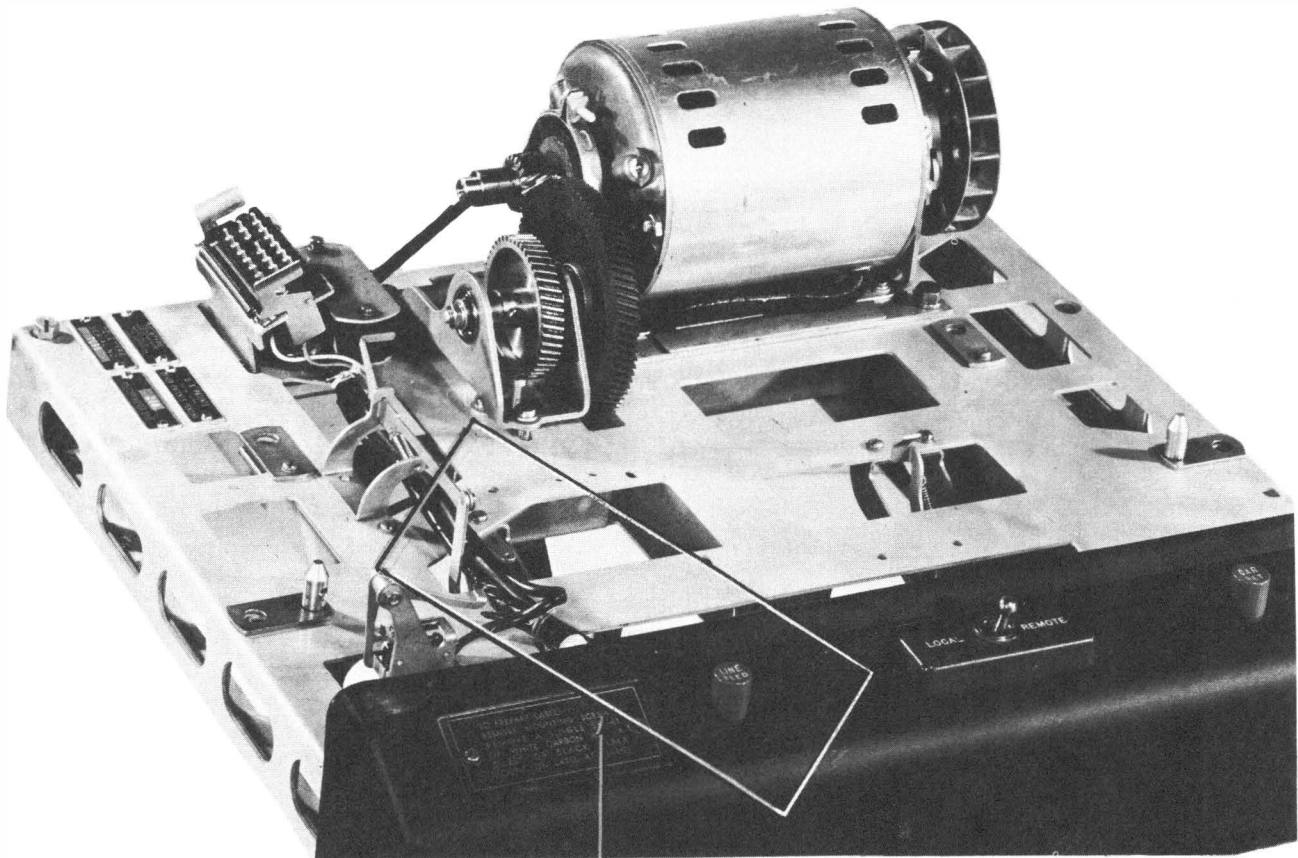

SIGNAL LINE BREAK

4.02 Signal Line Break Mechanism

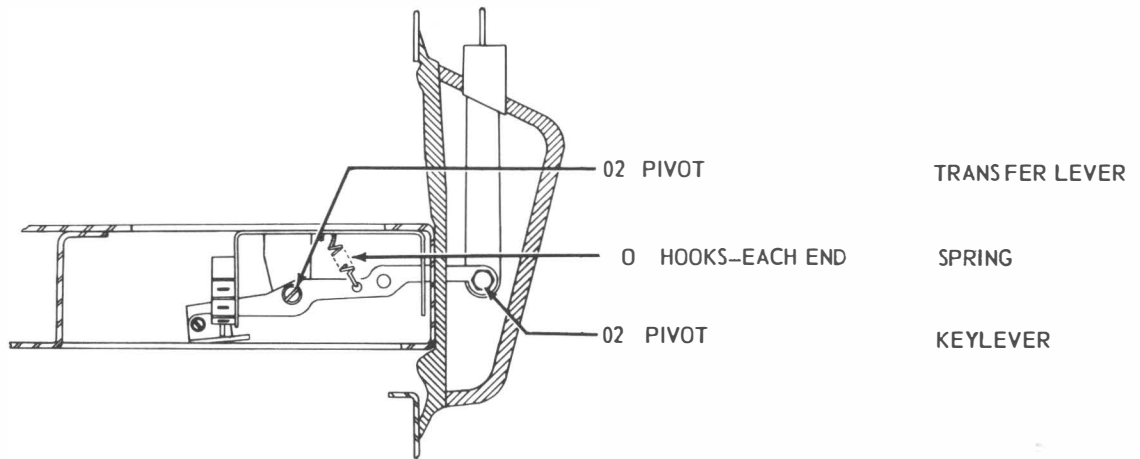



100-100-100-100-100



100-100-100-100-100

