

28 STUNTBX

DESCRIPTION AND OPERATING PRINCIPLES

CONTENTS	PAGE	CONTENTS	PAGE
1. GENERAL	1	13. AUXILIARY CONNECTORS AND CABINET TERMINALS	17
2. 28 TYPING UNIT - SELECTIVE - CALLING CONDITIONS	3	14. STUNTBX CAPACITY - NUMBER OF CODES	17
3. MECHANICAL FEATURES OF THE CODEBARS AND THE STUNTBX	6	15. SELECTIVE - CALLING TERMINOLOGY	18
A. Codebar Positions	6		
B. Basic Stuntbody Mechanisms	7	1. GENERAL	
C. Optional Stuntbody Mechanisms	7	1.01 This section gives the description and operating principles of the stuntbox used in the 28 typing unit and the 28 sequence selec- tor unit. Figures 1 and 2 are photographs of one arrangement. The basic description of the stuntbody mechanisms applies to the following stuntboxes:	
4. MESSAGE FORMAT	10		
5. USE OF LTRS CHARACTER WITH CONTROL CODES	10		
A. General	10		
B. Use of LTRS Character to Put 28 Typing Unit in Lower Case	10		
C. Use of LTRS Character with Reperforator Cut-on and Disconnect Codes	11		
D. Operation of Stuntbody Mechan- isms by LTRS Character	11		
6. FUNCTION BAR - DESIGN AND CODING	12		
7. OPERATION OF A 28 TELETYPE- WRITER FUNCTION	13		
8. OPERATION OF A SEQUENTIAL SELECTION OF A FUNCTION	14		
9. RELEASE OF LATCHED FUNCTION LEVERS	14		
10. OPERATION OF BUSY LAMP AND COPYLIGHT	15		
11. MOTOR CONTROL	16		
12. REMOTE CONTROL OF AUXILIARY APPARATUS	17		

<u>Letter</u>	<u>Number</u>	<u>Typing Unit</u>
AG	TP152804	28A, A1, and A2
AR	TP154944	28D, B, and C*
AN	TP152810	28E, F, and G
AED	TP157400	28H
ADA	TP154990-95	28A Sequence Selector

*These letters are out of alphabetical order to emphasize the point that the D unit corresponds to the E, the B to the F, and the C to the G. Refer to associated sections for the details of the differences.

Much of the discussion in this section concerns the selective-calling stuntboxes, AN, AED, and ADA. The AED and ADA stuntboxes in the 28H typing unit and the 28A sequence selector respectively are arranged exclusively for use with the 83B1 selective-calling system. More detailed information on these stuntboxes is given in associated sections. The stuntbox letter code is stamped on the head of the right-hand stuntbox mounting screw.

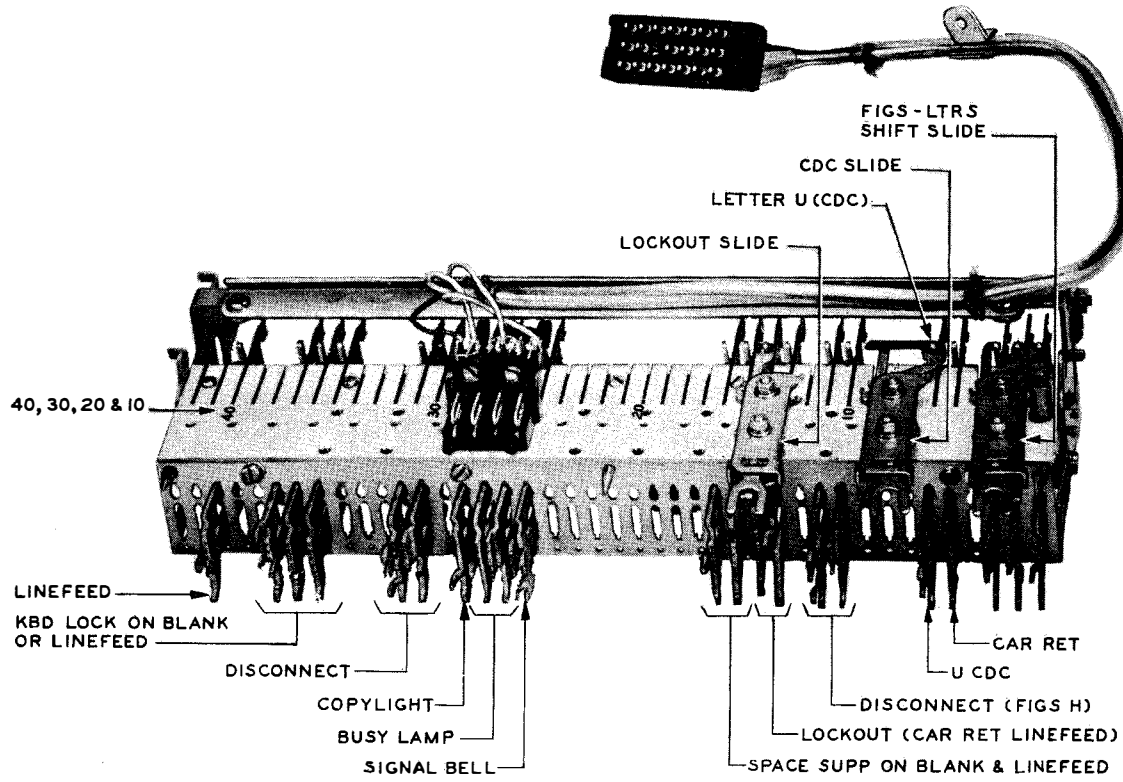

Figure 1 - AN Stuntbox - Front View (28E)

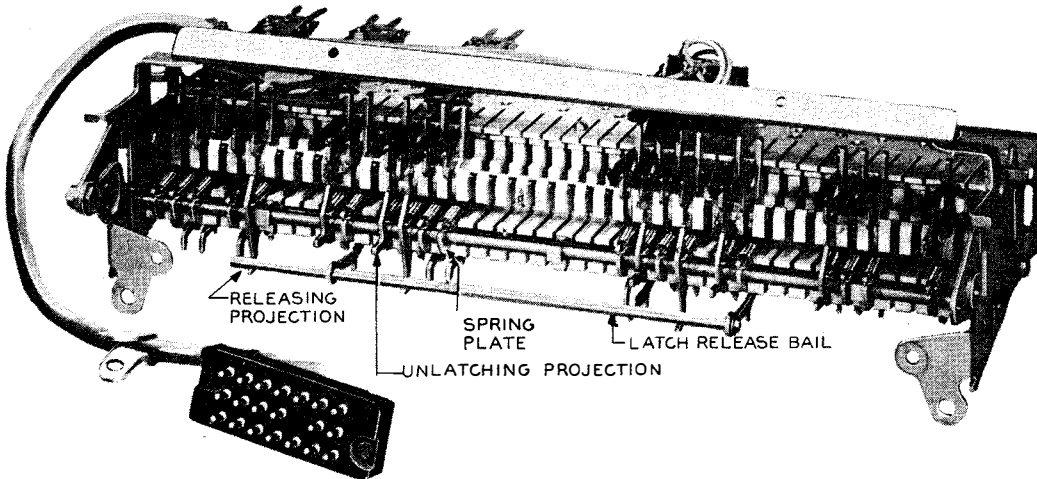

Figure 2 - AN Stuntbox - Rear View (28E)

1.02 The stuntbox is a necessary component of all 28 typing units to provide the mechanisms for various features associated with printing such as FIGS LTRS shift, carriage return, and line feed. When used for selective calling, additional mechanisms are installed whereby machines can be conditioned to print or not to print, or to operate contacts to control auxiliary apparatus.

1.03 Definitions of selective-calling terms are shown in 15.

1.04 The basic features of a selective-calling stuntbox are as follows:

(1) After a disconnect signal, and on the receipt of an assigned call-directing code (CDC) the stuntbox functions either to put the 28-type machine in condition to print or to operate contacts controlling auxiliary printing, perforating, or transmitting apparatus.

(2) After all desired CDC selections on a line have been made, a lockout or end-of-address signal conditions all machines so that CDC letter combinations occurring in message text do not call in any other machines.

(3) On the disconnect (end-of-message) signal, all 28-type machines are restored to a nonprint condition and all contacts are released to cut off auxiliary apparatus. In addition, all machines are put in a condition to respond to CDC's.

1.05 In the AN stuntbox, contacts are provided to light a copylight as an indication of an incoming call and to operate a busy lamp at all stations whether selected or not.

1.06 In the stuntbox of the 28H typing unit, aside from the basic selective-calling features, including CDC control of printing, and the features essential to printing, the contacts provided are those associated with the automatic controls of the 83B1 selective-calling system. The busy lamp and copylight controls are not needed with the automatic system, therefore the contacts for them are not provided on this stuntbox.

1.07 In the ADA stuntbox of the sequence selector, the contacts provided are only those needed with the 83B1 system. No features associated with printing are provided. The FIGS LTRS shift slide is omitted, since no distinction between upper and lower case characters is required.

1.08 Throughout this section, except where specifically indicated otherwise, the words "right" and "left" refer to the sides of the machine, or of its component mechanisms, as seen from the front or keyboard side. When the stuntbox mechanisms are pictured from the rear, the terms "right" and "left" will be opposite to the directions as they appear on the page.

1.09 The 28E, F, and G typing units (the AN stuntbox) have the basic parts for selective-calling operations. In all cases, some additional parts, such as function bars, function levers, and function pawls, must be added to equip the units to respond to the desired CDC's. Refer to the section covering 28 typing unit, installation of function parts on a 28 stuntbox.

1.10 On either selective-calling or nonselective-calling typing units a set of parts can be installed to close and latch a contact on one upper-case character and to unlatch the contact on another upper-case character. These are sometimes called reperforator control contacts, but they could also be used for other apparatus, such as a transmitter-distributor. The operation of these contacts is entirely independent of the selective-calling features. In associated sections, the contacts are described as closing on upper-case H and opening on upper-case F. On selective-calling machines, since upper-case H can not be used for this purpose, some other upper-case character must be chosen.

2. 28 TYPING UNIT - SELECTIVE-CALLING CONDITIONS

2.01 The conditions of the selective-calling typing unit with respect to selective-calling operations are determined by the position of the two codebars known as the print and select codebars, respectively. Their position in the codebar stack is shown in Figure 3.

2.02 Whether the machine is in the print or nonprint condition is determined by the position of the print codebar. This codebar, at the left-hand end, operates the blocking bail lever shown in Figure 4. In the left-hand or nonprint (marking) position of the codebar the blocking bail lever prevents the tripping of the typebox clutch so that printing and the functions associated with printing can not take place. The codebar in moving to the right-hand or print (spacing) position moves the blocking bail lever so that the typebox clutch is free to trip at the proper time in the operating cycle and complete a printing operation.

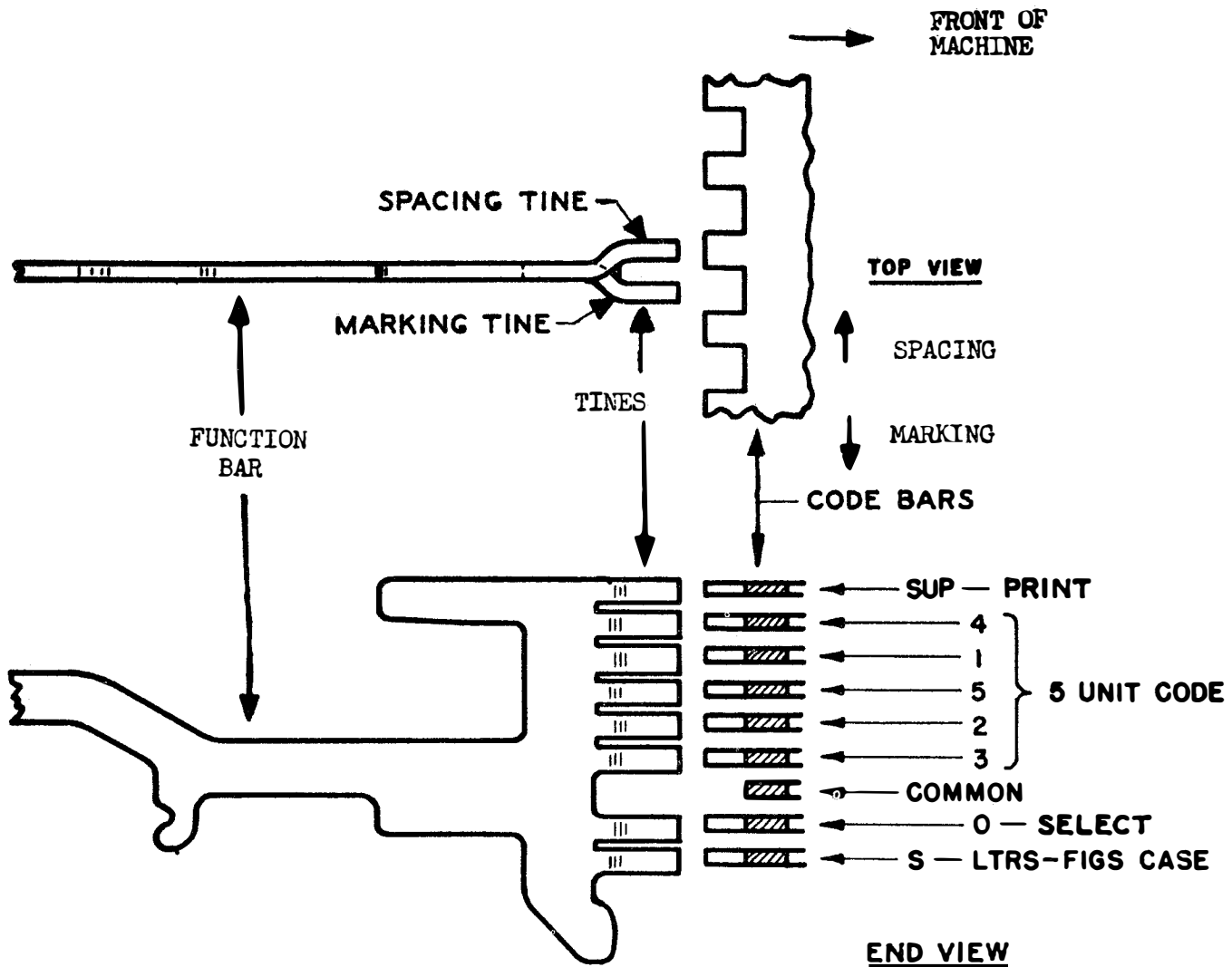

EACH TINE MAY BE FORMED TO PERMIT OPTIONAL SELECTION WHEN THE ASSOCIATED CODE BAR IS TOWARD THE LEFT (MARKING) OR RIGHT (SPACING). SELECTION IS PERMITTED IN EITHER CASE IF THE TINE IS OMITTED.

Figure 3 - Function Bar

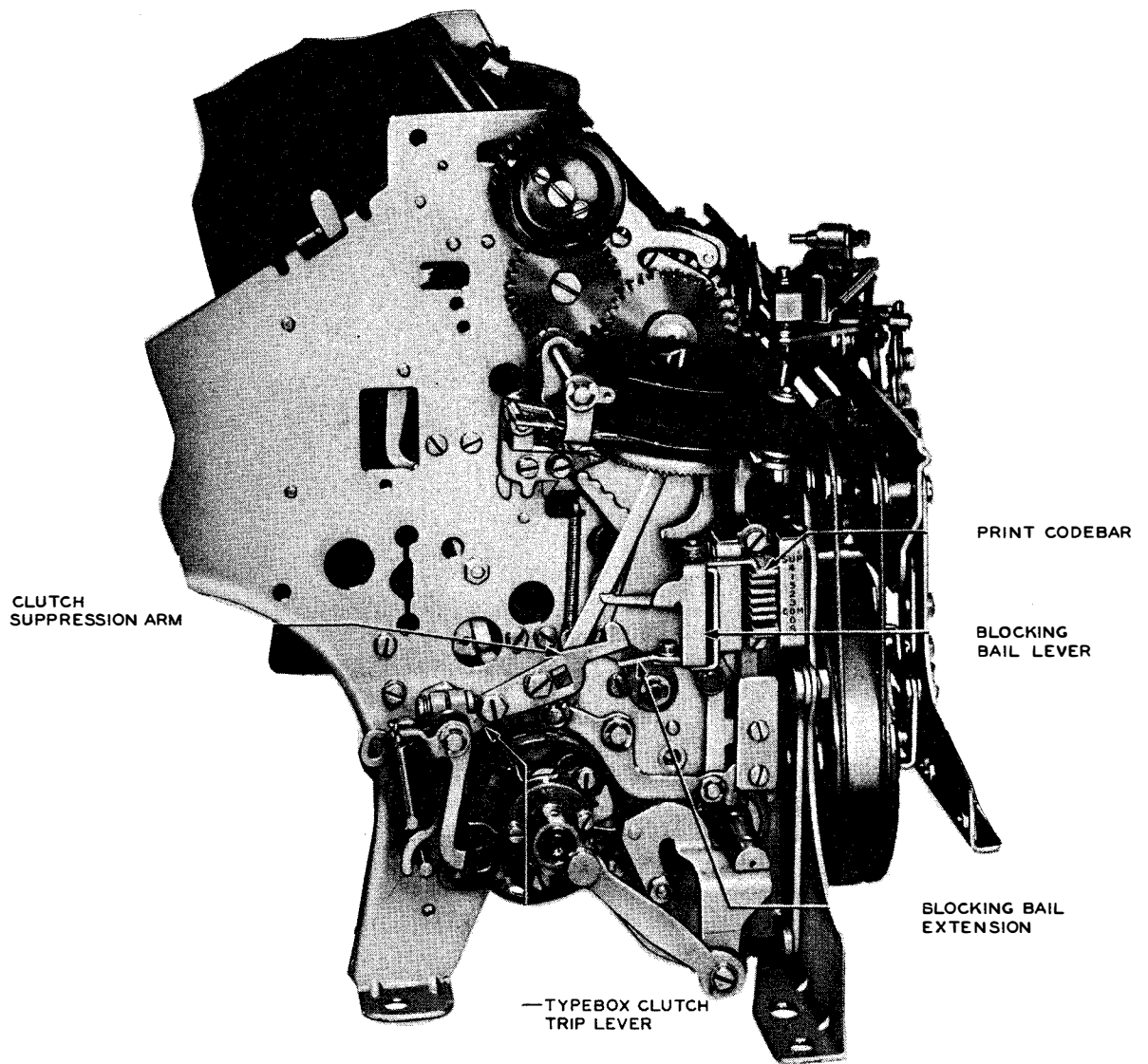

Figure 4 - 28E Typing Unit - Left-Hand End View

2.03 The typing unit is put in either the select or the nonselect condition by the position of the select codebar. In the select condition with the select codebar in the left-hand (marking) position, the stuntbox mechanisms respond to incoming CDC's, which shift the print codebar to put the unit in the print condition, or to operate contacts for the control of external apparatus. In the nonselect condition with the select codebar in the right-hand (spacing) position, the function bars can not go into selection because they are restricted by the select codebar.

2.04 The four selective-calling conditions of a typing unit are as follows:

- (a) Select-nonprint: In this condition teletypewriter will respond to CDC's but will not print. This condition will exist after receipt of the disconnect code.
- (b) Select Print: In this condition, a selected teletypewriter, in the print condition, can still respond to other CDC's to operate contacts on the stuntbox. This condition will exist after the receipt of the station CDC and before the receipt of the lockout code.
- (c) Nonselect Print: In this condition the teletypewriter will print but will not respond to CDC's or any selective-calling code except the disconnect code. This condition will exist at stations which have been selected and after the receipt of the lockout code.
- (d) Nonselect Nonprint: In this condition the teletypewriter will respond to the disconnect code only. It will not print in this condition. This condition will exist after the receipt of the lockout code at stations which have not been selected.

2.05 These conditions are summarized in Table A below.

TABLE A

Codes Received	Conditions	
	Selected Station	Unselected Station
Disconnect	Select and nonprint	Select and nonprint
CDC	Select and print	Select and nonprint
Lockout code	Nonselect and print	Nonselect and nonprint

3. MECHANICAL FEATURES OF THE CODEBARS AND THE STUNTBOX

A. Codebar Positions

3.01 The significance of the positions of the print, select, and FIGS LTRS shift codebars is summarized in Table B.

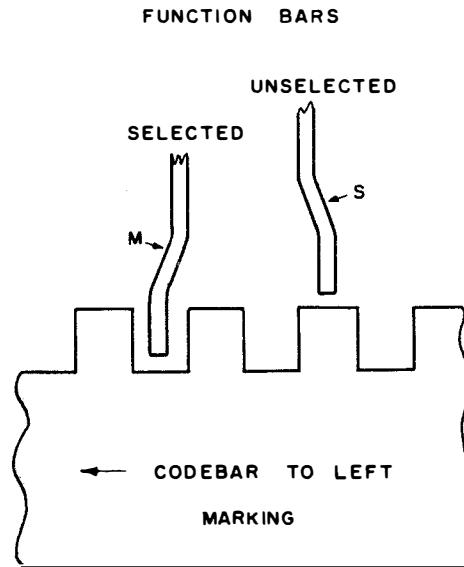

FRONT

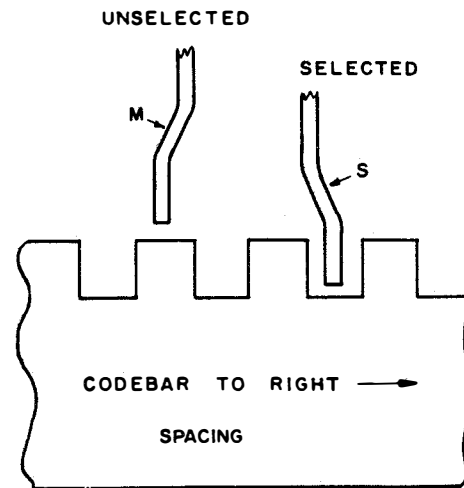

FRONT

Figure 5 - Function Bar Tines and Codebars

TABLE B

Codebar		Machine Condition	
<u>Desig*</u>	<u>Name</u>	<u>Codebar Left (M)</u>	<u>Codebar Right (S) See Note 1</u>
SUP	Print	Nonprint	Print
0	Select	Select	Nonselect
S	Shift	Upper Case (FIGS)	Lower Case (LTRS)

*Designation stamped on codebar detent bracket

Note 1: M and S, stamped on top of the codebar detent bracket, indicates marking and spacing. This correlates with the direction of the coding tines on the function bars. See Figure 5.

3.02 The position of the various codebars by means of the relation of the notches in them to the tines on the front of the coded function bars, determines which of the function bars go into selection. (See Figure 5.) This is described in detail in 7.

3.03 The print and select codebars are spring biased to the left (marking) position. They are moved and latched in the right (spacing) position by the action of their respective shift slides and associated function levers and function lever latches, which are provided with latching projections.

B. Basic Stuntbox Mechanisms

3.04 One or more CDC shift slides, on receipt of the assigned CDC, move the print codebar from the nonprint to the print position and latch it. It is released by the disconnect code.

3.05 A lockout shift slide which on receipt of the lockout code moves the select codebar from the select to the nonselect position and latches it. It is released by the disconnect code.

3.06 A latch release bail, actuated by the disconnect code, which unlatches the function levers associated with the CDC and lockout slides, permits the print and select codebars to move to the left position by means of their respective springs.

3.07 The function pawl stripper blade in the 28B, 28C, 28D, 28E, 28F, 28G, and 28H typing units is driven by the function clutch assembly. With this arrangement stuntbox operations can take place without activating the typebox clutch.

C. Optional Stuntbox Mechanisms

3.08 Function lever mechanisms which can be operated to open or close momentarily a contact in the stuntbox, for example a contact for a signal bell. Others can be added as options.

3.09 Function lever mechanisms which can be operated and latched to open or close a contact and be released on the subsequent downward motion of the stripper blade on the next character. The function can perform on a single letter or two or more letters in sequential order.

3.10 Function lever mechanisms which can be operated and latched to open or close a contact and be released on receipt of the disconnect code.

3.11 The above contact functions are obtained by means of the types of function levers and function lever latches which are shown in Figure 6. Normally open or normally closed contacts can be provided, depending on the shape of the insulator at the end of the contact arm. (See Figures 7 and 8.) These contact functions can be used to control remote apparatus, relay circuits, signal lamps, etc.

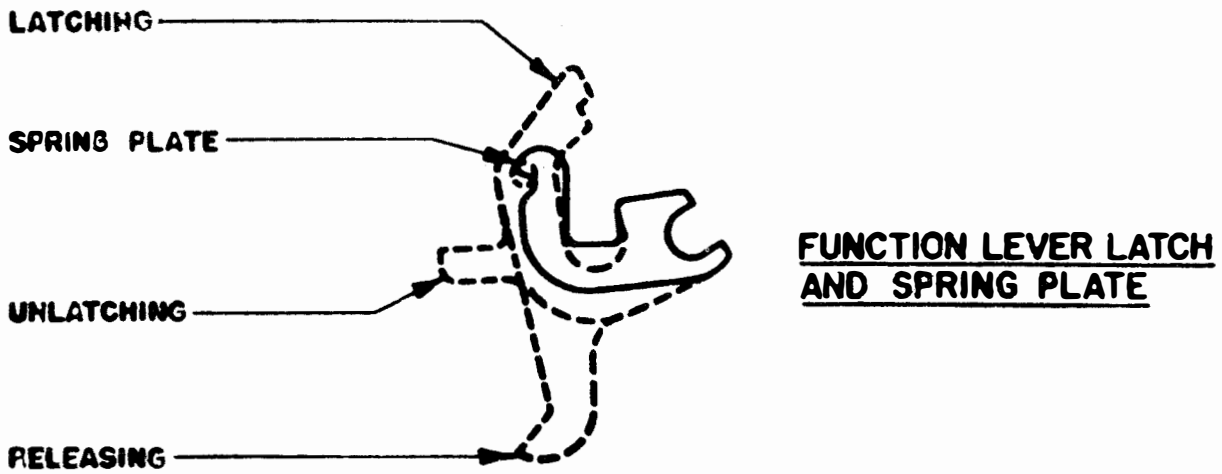
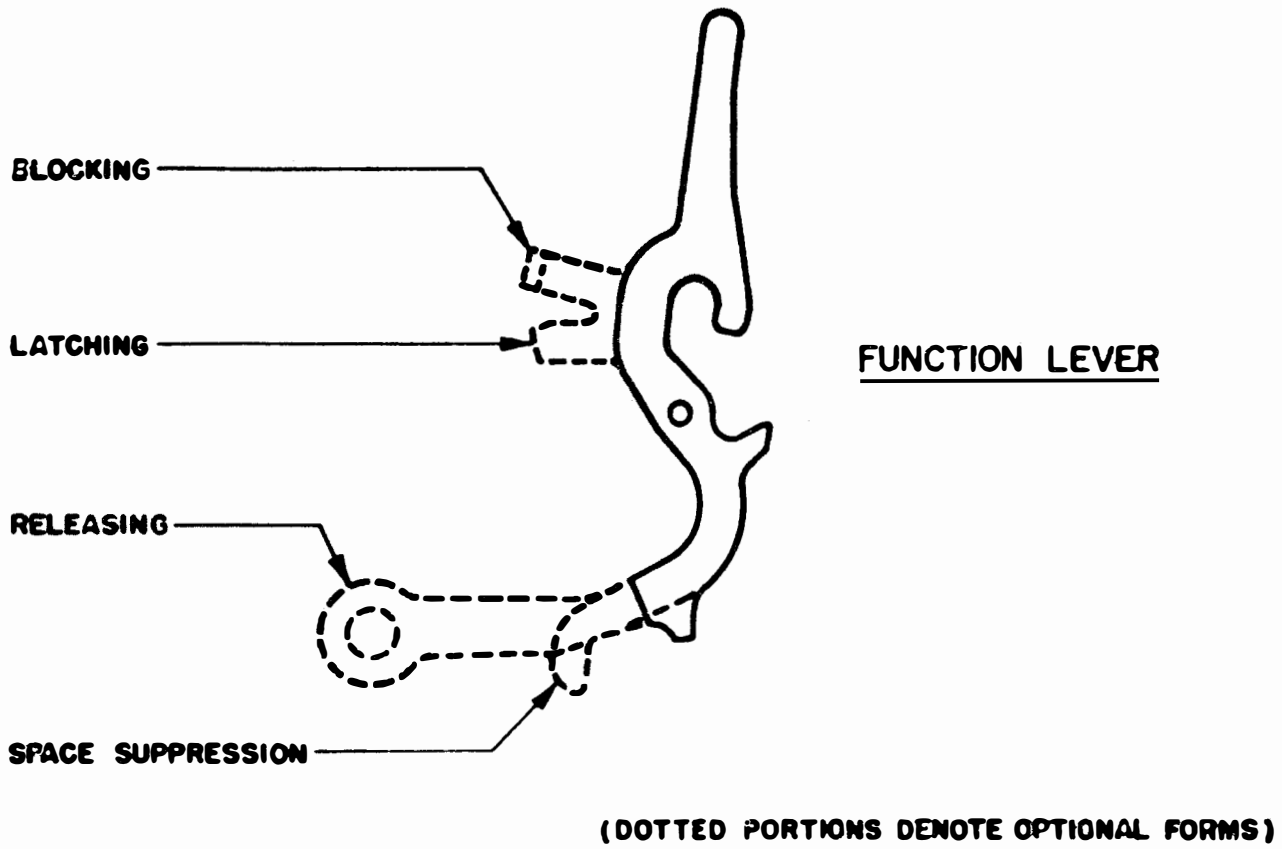

Figure 6 - Shapes of Function Levers and Latches

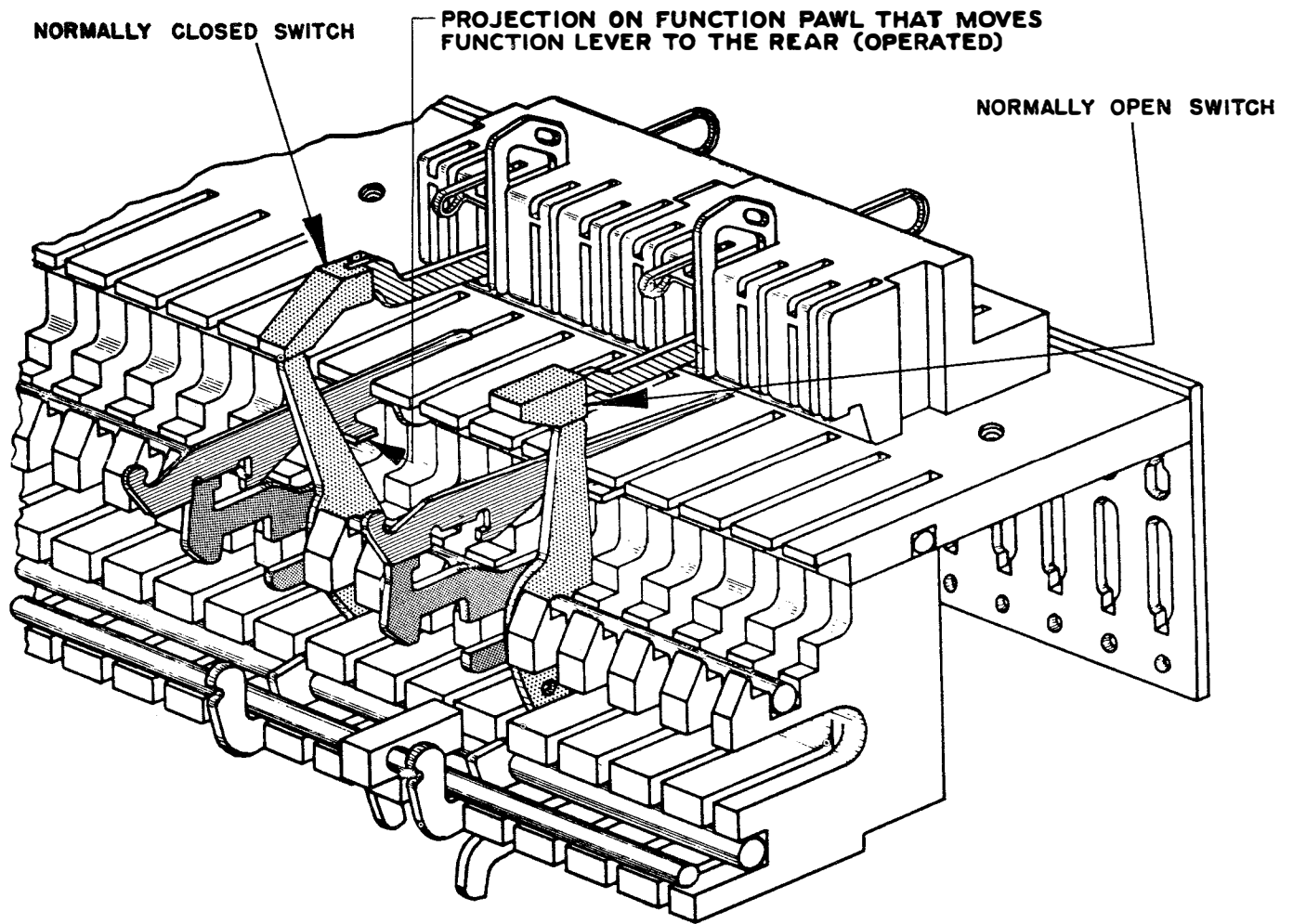

Figure 7 - Stuntbox with Switches

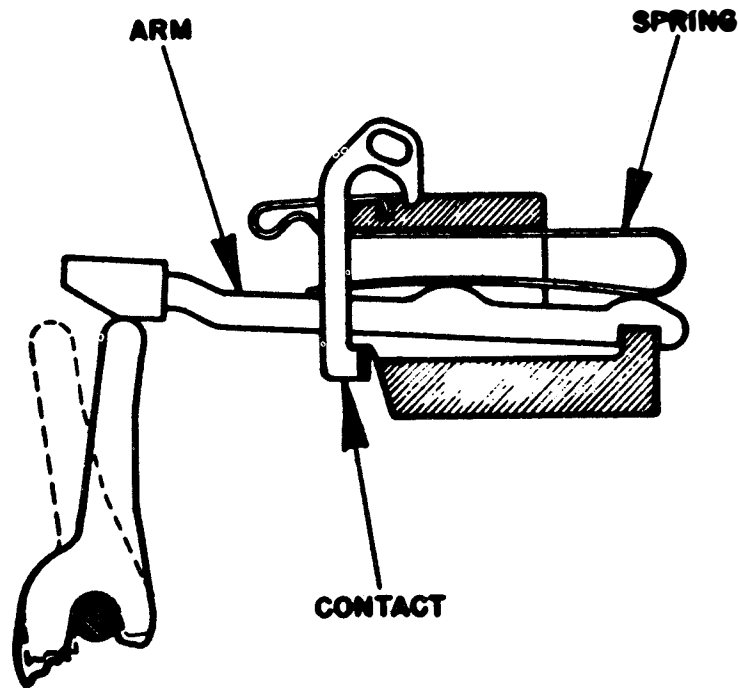

Figure 8 - Switch Mechanism

4. MESSAGE FORMAT

4.01 The message format, ie, the teletypewriter characters used to control selective-calling operations, is basic to the operation of the apparatus in the system.

4.02 The description in this section is written around a basic message format which is expected to be standard for most applications. However, because of the flexibility of the stuntbox and the ease of interchanging function bars, almost any desired format can be used for special applications.

4.03 The teletypewriter characters used to control selecting-calling operations are as follows:

FIGS H LTRS	Disconnect (End-of-message)
CDC LTRS	Station Call-directing Code
CAR RET LINE-FEED LTRS	Lockout (End-of-address)
FIGS BLANK H	Motor-stop Code. On non-selective-calling units FIGS H is an option.
CAR RET	Time Delay Motor-stop Disabler

5. USE OF LTRS CHARACTER WITH CONTROL CODES

A. General

5.01 Most of the control codes used with a 28 stuntbox end with a LTRS character. This character has different functions. Sometimes it is inserted merely for timing reasons. In other cases it is needed to get typing units into the lower case before printing begins. In some of these cases, the LTRS character initiates a stuntbox operation, in addition to the usual and essential shift of the FIGS LTRS codebar.

5.02 The discussion in the following paragraphs describes the various effects produced by the LTRS character and the reasons why it is necessary.

B. Use of LTRS Character to Put 28 Typing Unit in Lower Case

5.03 If LTRS were omitted after the CDC's used for switching selective-calling 28-type machines into the print condition, the first character printed would be in upper case and the second character in lower case. This would be caused by the following sequence of operations. The disconnect code puts the unit in the

select-nonprint condition. The LTRS character has moved the LTRS FIGS codebar to the LTRS position but since the typebox clutch does not trip, the typebox is not moved to the LTRS position but remains in the FIGS position. The next character, therefore, is printed in upper case after which the typebox shifts to the LTRS position. Subsequent characters are printed in lower case. The insertion of LTRS after each CDC corrects this condition by shifting the typebox into lower case before printing starts.

C. Use of LTRS Character with Reperforator Cut-on and Disconnect Codes

5.04 When either a CDC or a designated upper-case character is used to operate contacts to cut on an auxiliary machine, such as a typing reperforator, the LTRS character is required for timing reasons and to put the auxiliary machine into the lower case for the reception of the message.

5.05 The timing is needed because of the overlap in the operation of the 28 typing unit. When a CDC designated to operate a stuntbox contact is received in the selector mechanism of a 28 typing unit, the operations preceding the actual contact operation extend into about the third signal element of the next character. If the contact operation cuts on a machine, such as a reperforator, with another selector mechanism, this other mechanism does not receive the first part of the subsequent character. Therefore, the first character received, unless it is a LTRS character, is almost certain to be garbled.

5.06 As an illustration, assume that a teletypewriter stuntbox at Station A is equipped with selectively controlled contacts to cut on an associated reperforator transmitter and that these contacts operate on receipt of the CDC A. Assume that A is followed immediately by a letter B to initiate a selection at some other point on the circuit. On receipt of the letter A, the operations to cut on the reperforator transmitter at A commence. The contacts are not operated, however, until some time during the arrival of the letter B. The selector mechanism in the reperforator transmitter thus begins to receive signal elements from the line not at the start of B but in the middle of it. The first spacing element reaching the selector of the reperforator transmitter acts like a start element, which trips the selector clutch and registers a character, which will not be a B but some other character, dependent on the timing in the particular case and on the signal elements which follow the B character. Not only is a wrong

character registered, but the reperforator transmitter may be thrown out of synchronism for several characters.

5.07 If, on the other hand, a LTRS character is inserted between the A and the B, time is allowed for the completion of the contact operation initiated by A before the B signal starts to come in. LTRS is used because, after its start element, which is spacing, it consists of a single long mark. Thus if the reperforator transmitter is cut on in the middle of the LTRS character, its selector will receive a continuous mark and will be held in the stop position. Then, when the start element of B arrives, the reception of B will be normal and correct. The above discussion applies to tape sending, where there is continuous transmission and no time delay between a CDC and the next character. In the case of manual sending from a keyboard, there would often be enough time after the CDC was sent to permit the entire cut-on contact operation to take place before the next character was received.

5.08 In addition to the possible garbling of the first character, however, there would be another objectionable effect if LTRS were not sent after the CDC or cut-on code. All received text would be printed in upper case until a LTRS character was received. This is because the reperforator was left in upper case when it was cut off by FIGS H on the previous disconnect signal, the cutoff occurring on the H character before the LTRS character in the disconnect signal could be received by the reperforator.

5.09 It is essential for these types of operation that all CDC's be followed by a LTRS character for timing reasons.

D. Operation of Stuntbox Mechanisms by LTRS Character

5.10 In all typing units a LTRS character operates the FIGS LTRS shift codebar to condition the machine to print in the upper or lower cases, respectively. The sequence selector has no FIGS LTRS shift slide. In selective-calling machines, this codebar shifting takes place regardless of the condition of the machines. This operation, as such, does not affect the stuntbox. The discussion here is confined to stuntbox operations caused by the receipt of a LTRS character.

5.11 In the 28E, 28F, and 28G typing units, the only stuntbox mechanism involving a LTRS character is the one controlling the busy lamp.

The function of this is negative, ie, to prevent the lighting of the busy lamp if a series of LTRS characters are sent, after disconnect, for feeding out tape.

5.12 This is in contrast to the stuntboxes in the 28H typing unit and the 28A sequence selector, used with the 83B1 selective-calling system. In both of these stuntboxes, the disconnect mechanism, the latch release bail, is operated by a function-lever mechanism responding to LTRS. In the 28H typing unit, this is the second of a sequential pair of function lever mechanisms, the first of which operates on upper-case H, to unblock the second, which operates on LTRS.

5.13 In the ADA stuntbox of the sequence selector, a further modification was necessary for the reason that the stuntbox does not distinguish between upper- and lower-case characters. To prevent the possibility of a false disconnect on H LTRS, the latch release bail is driven by two sets of three function-lever mechanisms, each sequentially operated by the three characters, FIGS H LTRS.

5.14 The reason for making this difference in the stuntboxes used with the 83B1 system apparatus was primarily to simplify the design of the pushbutton calling circuit, by making it unnecessary to generate a LTRS character after each CDC.

5.15 There are two important results from this change:

(a) Since the LTRS character performs its functions in all connected machines before disconnect, they are left in the lower-case condition, so that the LTRS character after each CDC is not required to complete the FIGS LTRS shift.

(b) For proper operation, the operator can not omit the LTRS character (as was possible without this feature) so that garbled characters can not occur as a result of an inadvertent omission of LTRS by an operator. (In 83B1 system operation, if LTRS were omitted from the FIGS H LTRS code, an alarm would occur and the station would be locked out until the situation was corrected by the operator.)

5.16 It should not, however, be inferred from the above discussion that the LTRS character should be omitted after a CDC. It is still

required to prevent garbled characters in cases where the cutting on of a station, or of an auxiliary reperforator, is effected by stuntbox contacts. It is therefore suggested that universal use be made of the standard format proposed in 4. of this section.

6. FUNCTION BAR - DESIGN AND CODING

6.01 A function bar is coded by coding the tines in accordance with the code assigned to the bar. Viewing the function bar from the front, the left tines are marking and the right tines are spacing. Figure 5 shows two cases, one with the marking tine and the other with the spacing tine. The illustrative example following is for the tine opposite one codebar. When the codebar opposite these tines is in the left-hand or marking position, the left tine can move forward into selection. When the codebar is in the right-hand or spacing position the function bar with the tine goes into selection.

6.02 Each function bar can have up to eight tines, depending on the various combinations of codes used. (See Figures 3 and 9.) The example in Figure 9 is the function bar numbered TP155100, coded for the letter A, to go into selection when the machine is in the select condition. It consequently has a tine arranged to marking in the position opposite the select codebar. The code for the letter A is given by the five code-element tines, with 1 and 2 marking, and 3, 4, and 5 spacing. Since there is no tine in the shift codebar position, this bar will go into selection on either upper- or lower-case A. Also, since there is no tine in the print codebar position the bar operates independently of the machine condition with respect to print or nonprint. This particular bar is one of an alphabetical group used for CDC selection, either for selecting a station or operating auxiliary stuntbox contacts.

6.03 Other arrangements of tines are available for other requirements. As an example, the function bar controlling the signal bell on selective-calling machines is a print upper-case S bar. It moves into selection and closes the contact to ring the bell only when the typing unit is in the print condition and upper case S is sent. Thus the bell is not operated on unselected machines.

6.04 The following names may be used in discussions of coded function bars to indicate the conditions under which they will go into selection.

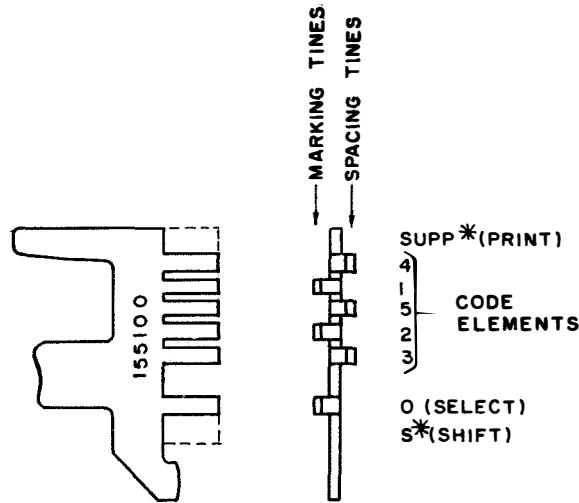

* THESE TINES NOT USED ON THIS FUNCTION BAR

Figure 9 - Function Bar Tines - Select A

Print
Nonprint
Upper Case

Select
Nonselect
Lower Case

As an example, the function bar associated with the line-feed signal in selective-calling machines may be designated a print line feed bar, indicating that it goes into selection only when LINE FEED is received and the print codebar is in the print position.

6.05 When any of these names are omitted, it usually means that the function bars have no tines opposite the codebars involved and so are not affected in this respect. However, teletypewriter practice for many years has been to omit "lower case" and assume that the lower case was meant unless upper case was indicated; therefore, in designing stuntbox arrangements requiring a definite performance, full information should be obtained as to the exact characteristics of the function bars to be used.

6.06 The TP153440 universal function bar can be coded in any manner desired. It has both marking and spacing tines in alleight codebar positions. Coding is accomplished by breaking off the undesired tines. The method of coding this bar is covered in the section entitled, 28 Typing Unit - Installation of Function Parts on a 28 Stuntbox.

7. OPERATION OF A 28 TELETYPEWRITER FUNCTION

7.01 When all of the codebars are so positioned that the tines of a particular function bar are all opposite slots, that function bar goes into selection.

7.02 Selection takes place as follows: As a typical example, assume that LINE FEED is the function to be performed. Figure 10 shows the condition of the function-bar mechanism for any other positioning of the codebars than that caused by the receipt of a LINE FEED signal. The LINE FEED function bar is prevented from going into selection by the codebars. The function pawl is not engaged with the function bar and the function lever remains unoperated.

7.03 When the code combination for LINE FEED is received by the line selector, the LINE FEED combination is set up in the codebars. When the function clutch is tripped following the selection cycle the function-bar reset bail, which up to this time has held the function bars away from the codebars, moves out of the way and all of the function bars in the stuntbox, pulled by springs, follow the function-bar reset bail forward and feel for an opening in the codebars. In this case, a free path is found only by the function bar coded for the LINE FEED code.

7.04 The entry into the codebars permits the function bar to travel far enough so that it becomes engaged with the associated function pawl. (See Figure 11.) All of the function bars are then pushed to the rear by the reset bail, driven by the function clutch. The LINE FEED function bar carries its function pawl with it. The function pawl in turn engages its companion function lever and trips the line-feed clutch to perform the line-feed operation. (See Figure 12.) The operation is completed when the stripper blade disengages the function pawl from the function bar. (See Figure 13.)

7.05 The space suppression projection of the function lever pushes the space suppression bail forward to prevent spacing. This projection of the function lever can be omitted when spacing on a function is desired. (See Figure 6.)

8. OPERATION OF A SEQUENTIAL SELECTION OF A FUNCTION

8.01 Basic to the operation of the selective-calling stuntbox is the sequential operation of adjacent function lever mechanisms. These are required whenever control codes consist of two or more teletypewriter characters. This sequential operation is employed in the selective-calling stuntbox, but can also be used in non-selective-calling typing units. Examples of sequential operation in the 28D, 28B, and 28C typing units are remote motor control on FIGS BLANK H, and keyboard lock on DOUBLE BLANK. See associated sections.

8.02 To describe the detailed performance of a stuntbox in such sequential operation, the effects of an incoming code FIGS H on a machine arranged to respond to it are considered here. In this case, two function-bar mechanisms, located in adjacent slots and coded to go into selection on FIGS and H, respectively, are required.

8.03 All sequential functions operate in a left to right direction as viewed from the rear of the teletypewriter. Therefore, FIGS and H mechanisms are installed in the stuntbox so that the FIGS mechanism, which acts as a gate, is immediately to the left of the H mechanism.

8.04 The assembly of parts for the FIGS H sequential operation is shown schematically in Figure 14. The FIGS mechanism in the FIGS H sequential combination differs in that the function lever has blocking and latching projections and the function lever latch has latching and unlatching projections. (See Figure 6.)

8.05 As shown, the blocking projection of the function lever extends across to the H function bar. With the FIGS function lever latched in its operated position, the H function bar is free to go into selection on the receipt of an H signal. (See Figure 14.) If the FIGS function lever were unoperated, its blocking projection would be positioned in the notch of the H function bar as shown by the arrow, marked X, thus preventing its forward motion into selection.

8.06 The sequence of operation is then as follows: On the receipt of a FIGS character, the FIGS function lever is operated and latched, as shown in Figure 14. Its blocking projection is now out of the way of the H function bar. As H is the next character, the H function bar can go into selection and operate the H function lever. This lever may close or open a contact or operate a mechanical linkage, not shown here.

8.07 After the H function bar is selected, the stripper blade travels down from its normal position, moving the unlatching projection of the FIGS function lever latch and unlatching the FIGS function lever, which returns to its unoperated position, preparatory to blocking the H function bar from further selection after it has completed its cycle. After the H function lever has operated, the stripper blade on its upward motion in its cycle, strips the H function pawl off its function bar. The stripper blade now moves downward to its normal position, completing the cycle.

8.08 Had the FIGS signal been followed by any other character than H, the stripper blade would have unlatched the FIGS function lever and blocked the H function bar so that it would not be selected by any subsequent H signal. The FIGS and H characters must be in consecutive order for operation of the final function.

8.09 This sequential method of selection can be extended to require three, four, or more characters in exact order to perform the desired operation. In effect, the first function bar opens a gate for the second and then closes the gate immediately after the next character has been received and the second bar has had an opportunity to take advantage of the opening. The second one in turn opens a gate for the third and so on.

9. RELEASE OF LATCHED FUNCTION LEVERS

9.01 In 8.07 the method of unlatching a function lever by means of the stripper blade is described. This occurs on the next operation

after that which latched the lever. If the function lever is to remain latched until the receipt of a code assigned to release it, a different arrangement is required. The function lever latch as shown in Figure 6 is provided with the releasing projection instead of the unlatching projection. The function lever is then unlatched when the releasing projection of its function lever latch is operated by the latch release bail, as shown in Figure 2.

9.02 A spring plate is used in place of a function lever latch when latching, unlatching, or releasing projections are not required, ie, for momentary operations (Figure 6).

9.03 A latch release bail consists of a rod attached at or near its ends to two function levers provided with a releasing projection. (See Figures 2 and 6.) It requires the simultaneous operation of the two levers to operate the bail. Therefore, duplicate mechanisms are required, one at each end of the rod. In the AN stuntbox the H function levers are located in slots 11 and 31 and the latch release bail extends from slot 6 to slot 31. See Figure 15.

9.04 The mechanism shown in Figure 2 requires the sequential operation of two function levers, duplicated at both ends, to operate the latch release bail. In this case the function bar mechanisms are coded to operate on the sequence FIGS H as described in 8. On receipt of the H, the two H function levers carrying the latch release bail operate and, by means of the releasing projection on the latch, trip the function lever latch and thus release it.

9.05 The function lever mechanisms which operate on the final letters of CDC's to shift the print codebar to the print position latch in a similar manner. The latch is released by the latch release bail on the disconnect signal.

10. OPERATION OF BUSY LAMP AND COPY-LIGHT

10.01 The 28E, 28F, and 28G typing units are provided with a stuntbox contact block at slots 25 through 28 equipped with contacts to control the copylight and the busy lamp. (See Figure 15.) The copylight is arranged to light on each selected machine to indicate that it has been selected. It is not lighted on unselected machines.

10.02 The busy lamp is lighted on all machines on a circuit on the first character (except LTRS) received after the disconnect signal.

Since there are several ways, including a momentary line hit, in which the busy lamp can be lighted falsely, an additional contact is provided to flash the lamp on every SPACE character as an indication to an attendant, particularly at an unselected station (which does not print), that traffic is going over the circuit. If the busy lamp does not flash for a period of about ten seconds an attendant may usually assume that the circuit is not busy.

10.03 Both copylight and busy lamp are extinguished by the disconnect signal. The details of the operation of the copylight and busy lamp contacts are described below.

10.04 The function lever mechanism, in slot 28 of the stuntbox, associated with the copylight contact is provided with a function bar coded Print Select Universal. Thus after a machine has been selected by means of a CDC and the print codebar shifted into the print condition on the next character, regardless of what it might be, operates the copylight contact. The contact remains closed since the function lever operating it is latched operated by means of a latching projection and the function lever latch. The function lever latch is provided with a releasing extension so that it is unlatched, and the contact opened, by means of the latch release bail on the disconnect signal.

10.05 The busy lamp is controlled by a contact operated by a function lever mechanism in slot 26 of the stuntbox. The associated function bar is coded LTRS. The function lever differs from the other function levers in two respects. In the first place it is provided with an extension at the bottom which engages with the latch release bail in such a manner that the function lever is operated by the latch release bail on the disconnect signal. Also it has a blocking extension similar to that on other function levers except, in this case, the blocking extension instead of extending over and blocking the function bar in the next higher numbered slot, is bent back on itself so that when the function lever is not operated, it prevents the function bar (LTRS) from moving forward into selection. The function lever latch is equipped with the usual latching projection so that it is unlatched by the stripper blade. (See Figure 6.)

10.06 The operation of this mechanism is then as follows: On the disconnect signal the function lever is operated and latched in the operated position. This opens the busy lamp contact. On the receipt of the LTRS character, in this case, in the FIGS H LTRS combination, the

function lever is unlatched by the action of the stripper blade and tends to move forward to its unoperated position. However, at the same time the LTRS function bar, which was unblocked because the function lever was operated, moves forward into selection and now reoperates the function lever to its latched position on its backward motion. Thus the contact, closing momentarily, is immediately reopened. This action will continue for as many LTRS characters as are sent in succession.

10.07 If, however, any character other than LTRS is received, such as a CDC, the stripper blade will unlatch the function lever, permitting it to move to its unoperated position and thereby closing the contact and lighting the busy lamp. With the function lever in its unoperated position the LTRS function bar is now blocked from moving into selection on any subsequent LTRS character. Thus the busy lamp remains lighted until the disconnect signal is received, at which time the cycle of operations is restarted.

10.08 The function lever mechanism in slot 27 operates on every SPACE character to open a contact in series with the busy lamp contact, thereby flashing the busy lamp when it is lighted.

10.09 Since the busy lamp will light upon the receipt of any character, except LTRS, it will light upon the receipt of a line hit which is long enough to simulate any character except LTRS. It will also light when the motor is turned on. This is because the turning off of the motor results in the release of the line shunt relay. The machine will "run open" therefore, while the motor is slowing down, setting up a BLANK selection in the machine and closing the busy lamp contact. The lamp will light, therefore, as soon as the power is applied again to turn on the motor. In any case of such a false busy signal the lamp can be put out by sending FIGS H LTRS.

11. MOTOR CONTROL

11.01 The 28E, 28F, and 28G typing units can be optionally equipped with sets of parts for motor control. It is not contemplated that this method will be used to stop the motors after each individual message but rather at the close of the circuit service hours only.

11.02 These sets of parts are as follows:

- (a) Upper case BLANK H function lever mechanisms and set of contacts in the stuntbox, at slots 32 and 33.

- (b) Electrical motor control assembly on the electrical service unit. Required with (a).

- (c) Time-delay motor-stop mechanism on the base which measures a predetermined time interval, during which no signals are received, and thereafter activates the associated electrical motor stop assembly to stop the motor. Optional addition to (a) and (b).

- (d) Time-delay motor-stop disabler mechanism which consists of a normally closed contact in the stuntbox, at slot 34, wired in series with the contact of the time-delay mechanism. Optional addition to (c).

11.03 The purpose of the time-delay motor-stop mechanism is to stop the motor whenever the teletypewriter runs idle for longer than one to three minutes. For a description of its operation refer to associated sections.

11.04 The purpose of the time-delay motor-stop disabler is to prevent the operation of the time-delay motor-stop mechanism. It is controlled by the CAR RET character. Usually when these features are used, the operator, at the start of business for the day, starts all motors and then sends CAR RET, so that the time-delay motor-stop mechanism is not operative until FIGS BLANK H is sent. Thus if FIGS BLANK H is not sent until the termination of the service period the motors would not stop due to idle circuit time during the service hours.

11.05 For selective-calling use the motor stop code actuates the motor stop contact only when the unit is in the select-nonprint condition, ie, after the disconnect code. This is obtained by (1) coding the upper case BLANK function bar to go into selection in the select condition only, and (2) coding the upper case H function bar to go into selection in the nonprint condition only. The H function lever, in slot 33, is equipped with a releasing projection and a short latch release bail which spans the function lever in slot 34.

11.06 The time-delay motor-stop disabler consists of the function lever mechanism and a normally closed contact in slot 34. The associated function bar is coded CAR RET and non-restricted as to selection. The function lever is provided with a latching projection and the function lever latch is provided with latching and releasing projections. The contact is latched open on receipt of CAR RET thereby disabling the time-delay motor-stop mechanism. The contact is unlatched by means of the short latch release bail on the function lever in slot 33 which is operated on receipt of the motor stop code.

11.07 It should be noted that slots 32, 33, and 34, assigned to motor control, are outside the slots spanned by the latch release bail controlled by the disconnect code.

11.08 Motor control arrangements are not available for the 28A sequence selector.

12. REMOTE CONTROL OF AUXILIARY APPARATUS

12.01 Remote control of auxiliary apparatus, such as typing reperforators, transmitter-distributors, indicating lamps, signal bells, etc, may be provided by means of contacts on the stuntbox. The contacts are assembled in molded plastic blocks arranged to hold groups of four contacts. The operation of these contacts by function-lever mechanisms is illustrated by Figure 7, and the details of the contacts by Figure 8. As shown, either make or break contacts can be provided.

12.02 There are two separate categories of such contact operation. The first is where, on selective calling machines, the contacts are operated by CDC's. Operation may be either (1) momentary, (2) latching until unlatched by the stripper blade on receipt of the next character, or (3) latching until released by the latch release bail on the disconnect signal.

12.03 The second category are contacts which operate and latch on one upper-case character and unlatch on another upper-case character. These contacts have sometimes been called H and F contacts because they often use those upper-case characters. These contacts may be installed on either selective-calling or nonselective-calling machines, with the following exceptions in the case of selective-calling machines:

- (a) They can not be installed in any slots spanned by the latch release bail, since the mechanisms would interfere.
- (b) They can not use upper-case H as a control code as that is already used for the disconnect signal. Another upper-case character must be chosen.

Operation of contacts in this second category is entirely independent of the selective calling features of the machine. They could be used, for instance, to add and remove a reperforator during the course of a message without the necessity of sending a disconnect signal and then re-establishing the desired circuit arrangement by sending CDC's.

13. AUXILIARY CONNECTORS AND CABINET TERMINALS

13.01 On the AN stuntbox, all the wiring has been cabled to an auxiliary (right) typing unit 20-terminal connector and arranged in such a way that the stuntbox, cable, and connector can be taken off as a unit without disconnecting any wires. Four of the wires are used for the signal bell, copylight, and busy lamp contacts. The other 16 are spare for use with future contact additions. In addition, each 28E, 28F, or 28G typing unit is furnished with the other half of the connector, a cable, and terminal blocks to be mounted on the right-hand wall of the teletypewriter cabinet. The terminals will be numbered C41 to C80, to fit into the existing cabinet system. For cabinet wiring refer to the section covering 28 teletypewriter cabinet wiring diagrams.

13.02 For the 28H typing unit, because of the larger number of wires required, a 35-terminal connector is provided. The other half of the connector, cable, and cabinet terminal blocks are also provided. The 28A sequence selector also has a 35-terminal connector. However, since the wiring to the sequence selector will be a part of the apparatus cabinet assembly it will not be furnished with the selector.

14. STUNTBX CAPACITY - NUMBER OF CODES

14.01 In evaluating the capacity of the selective-calling system it is important to distinguish between the total number of stations which can be selected and the number of different codes to which one particular station can be equipped to respond.

14.02 Twenty single letter CDC's are generally considered to be available, the letters T, O, M, V, U, and H being excluded. T, O, M, and V are less desirable because they can be produced by line hits. U is reserved for the broadcast code and H as a disconnect or other control code. Thus with single letter CDC's, twenty stations or functions may be selected.

14.03 Using two-letter CDC's, 400 codes are available and 400 different stations or functions can be selected.

14.04 The number of different codes which can be used to operate contacts or call in any one station depends on the number of usable slots in the stuntbox. The figures given herein

are based on the assumption that, as a general principle, slots which are reserved for optional functions not always provided, such as motor control, horizontal tabulation, etc, will remain vacant when the options are not provided. Figure 15 shows the slot and contact arrangement for the AN stuntbox. It will be noted that the latch release bail extends from slot 6 to slot 31. In this stuntbox there is a print codebar operating bracket located above the codebar stack and extending from slot 8 to slot 35. There are holes drilled in it in which an operating bracket post can be placed so that a CDC shift-slide fork will engage it and operate the print codebar. By this means, more than one CDC shift slide can be installed on the stuntbox. There is a CDC shift slide which can be operated by function levers in slots 6, 7, 8, and 9. (See Figure 15.) Four single-letter or two two-letter CDC's can be used. If desired an additional CDC shift slide can be added to double this capacity. It would be positioned so that function levers in slots 21, 22, 23, and 24 would operate this shift slide. Where this is done, the spare slots, 18, 19, 20, and 29, will permit the operation of four latching contacts on single-letter CDC's or one latching contact on a two-letter CDC. The reservation of slot 17 for horizontal tab results in an arbitrary restriction here.

14.05 If the second CDC shift slide is not required, there are eight spare slots, 18, 19, 20, 21, 22, 23, 24, and 29, available for latching contacts and, therefore, eight single-letter functions, other than station selections, can be performed. Using two-letter codes only three latching contacts can be used; two of the eight slots are not adjacent and so can not be paired.

14.06 With either of the above CDC shift slide arrangements, slot 38 is available for a momentarily operated contact, since it is outside the span of the latch release bail.

14.07 If the necessity were great enough a CDC shift-slide could be mounted and operated by function levers in slots 33 and/or 34. The shift-slide fork would engage an operating bracket post in the hole of the print codebar operating bracket opposite slot 35. This would require a special extension of the latch release bail.

14.08 It is not desirable to mount shift slides side-by-side because of mutual interference which makes adjustment difficult.

15. SELECTIVE-CALLING TERMINOLOGY

15.01 The more commonly used terms in selective-calling arrangements utilizing the 28 stuntbox are defined in the following.

15.02 Selective Calling: A system or arrangement which provides for the selection of individual stations or groups of stations on a multistation line by means of call directing codes (CDC's) sent from a teletypewriter keyboard, tape transmitter, or by pushbuttons. It also provides for the selective operation of contacts in the stuntbox for the control of external apparatus. The codes are composed of the 5-unit teletypewriter characters either singly or in group combinations.

15.03 Call-Directing Code (Abbreviated CDC): A code composed of one or more teletypewriter characters which is used to put a designated station in a condition to receive a message. In the case of a 28 selective-calling teletypewriter, on receipt of its assigned CDC the machine shifts from the nonprint into the print condition. A CDC may also close or open contacts to control auxiliary apparatus, as in the case of the 19 ASR set controlled by the sequence selector in the 83B1 system. A particular station may have more than one CDC, as required, including a group CDC. A broadcast CDC can be assigned to call in all of the stations on a circuit at once. (In some other applications CDC is used to mean Call-directing Character; it is not so used herein.)

15.04 Lockout Code (End-of-Address): This code is usually CAR RET LINEFEED LTRS. This code conditions all machines so that further CDC station selections do not occur from CDC letter combinations in message text.

15.05 Disconnect Code (End-of-Message): This code is usually FIGS H LTRS. This code disconnects all connected machines, either teletypewriters or associated reperforators, and puts these stuntboxes in condition to respond to CDC's.

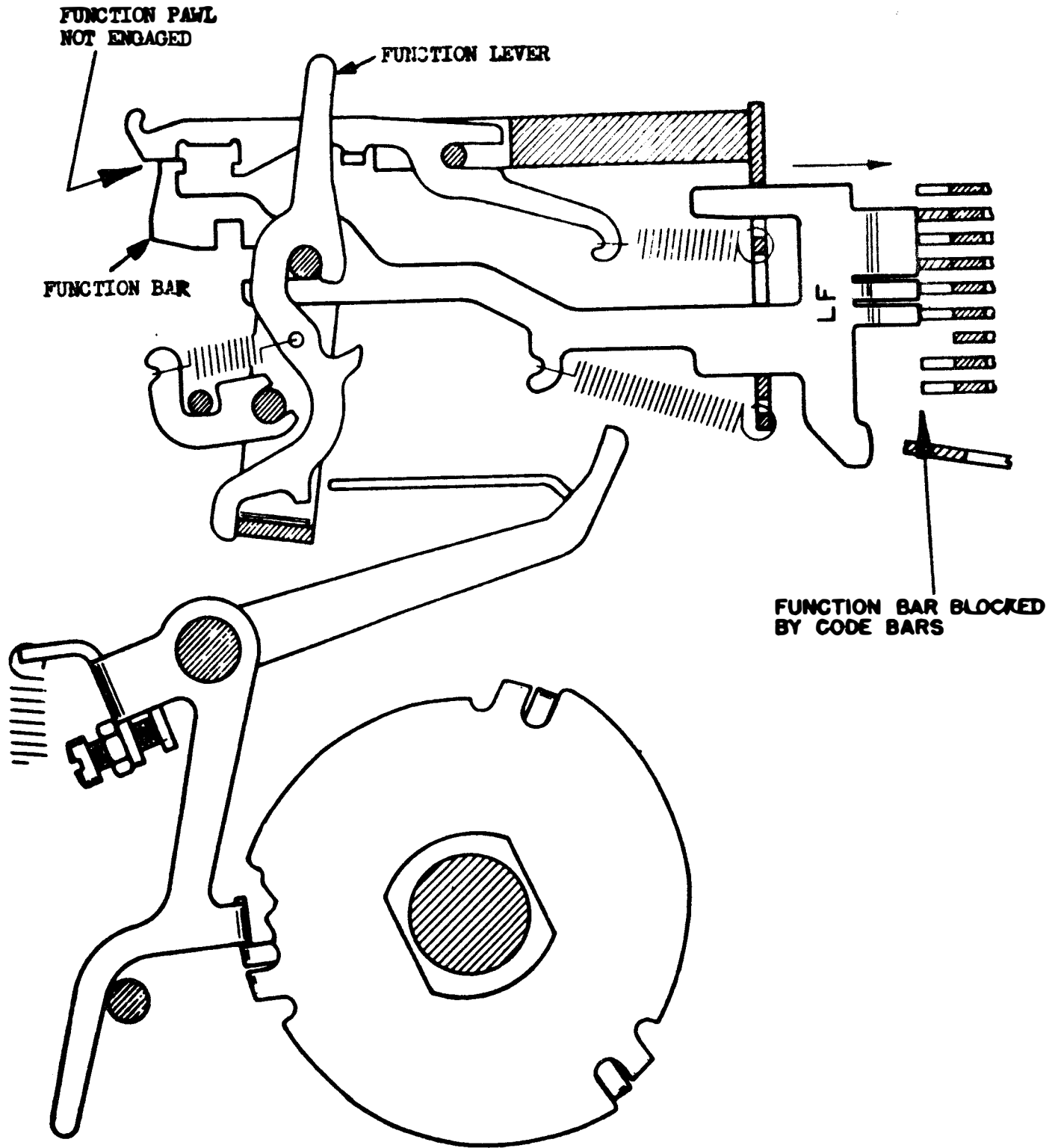

Figure 10 - Operation of a Printer Function

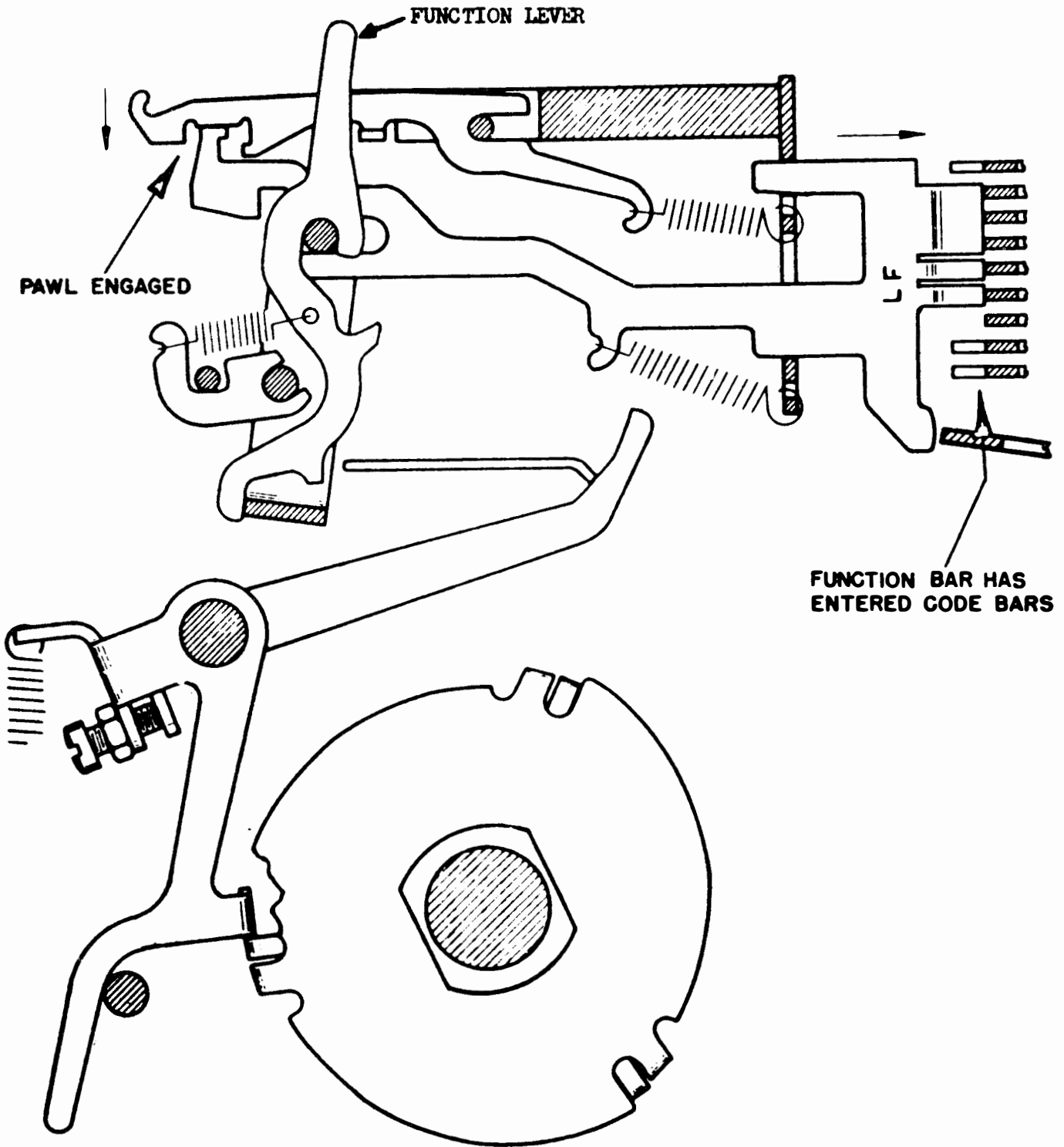

Figure 11 - Operation of a Printer Function

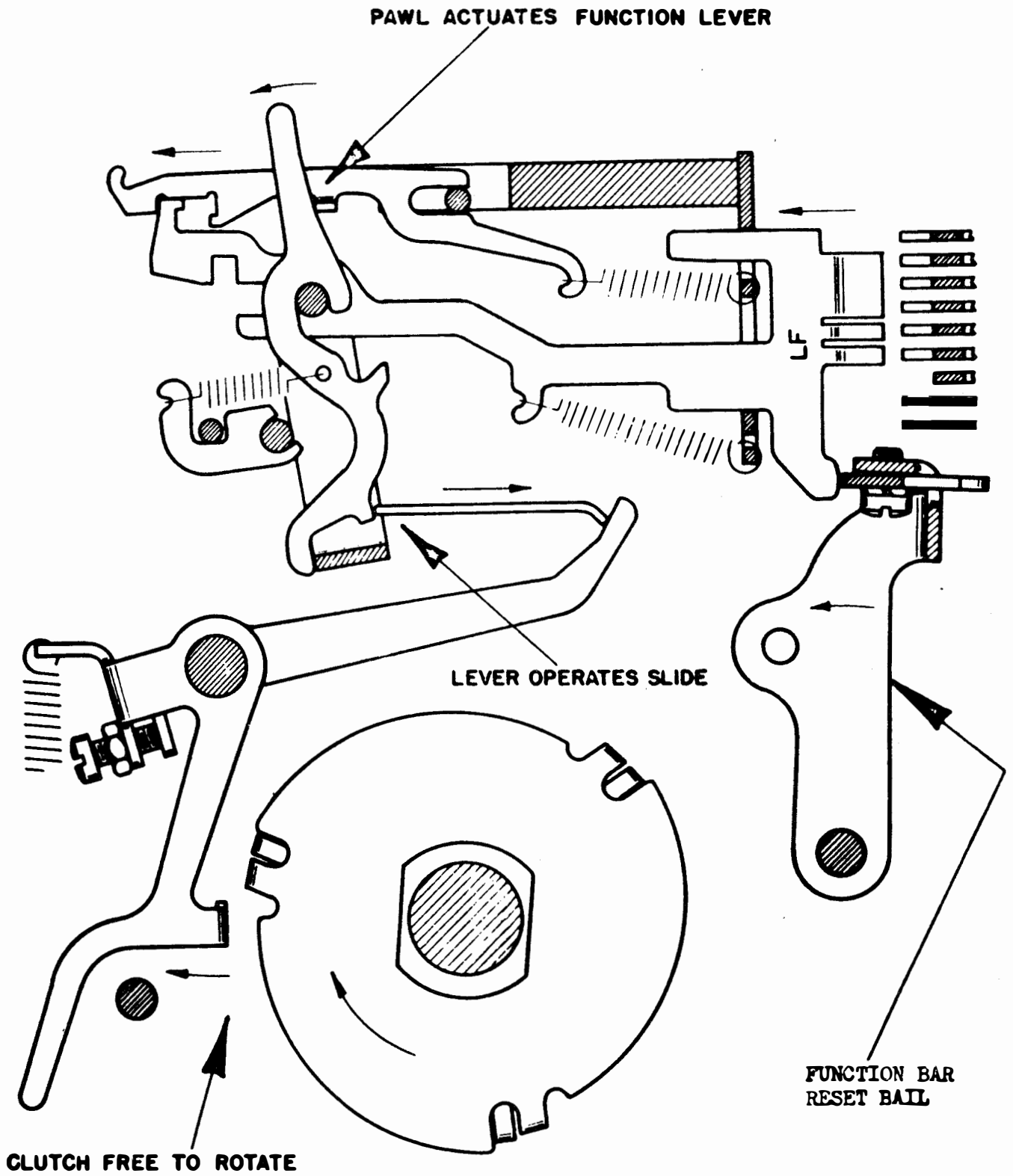

Figure 12 - Operation of a Printer Function

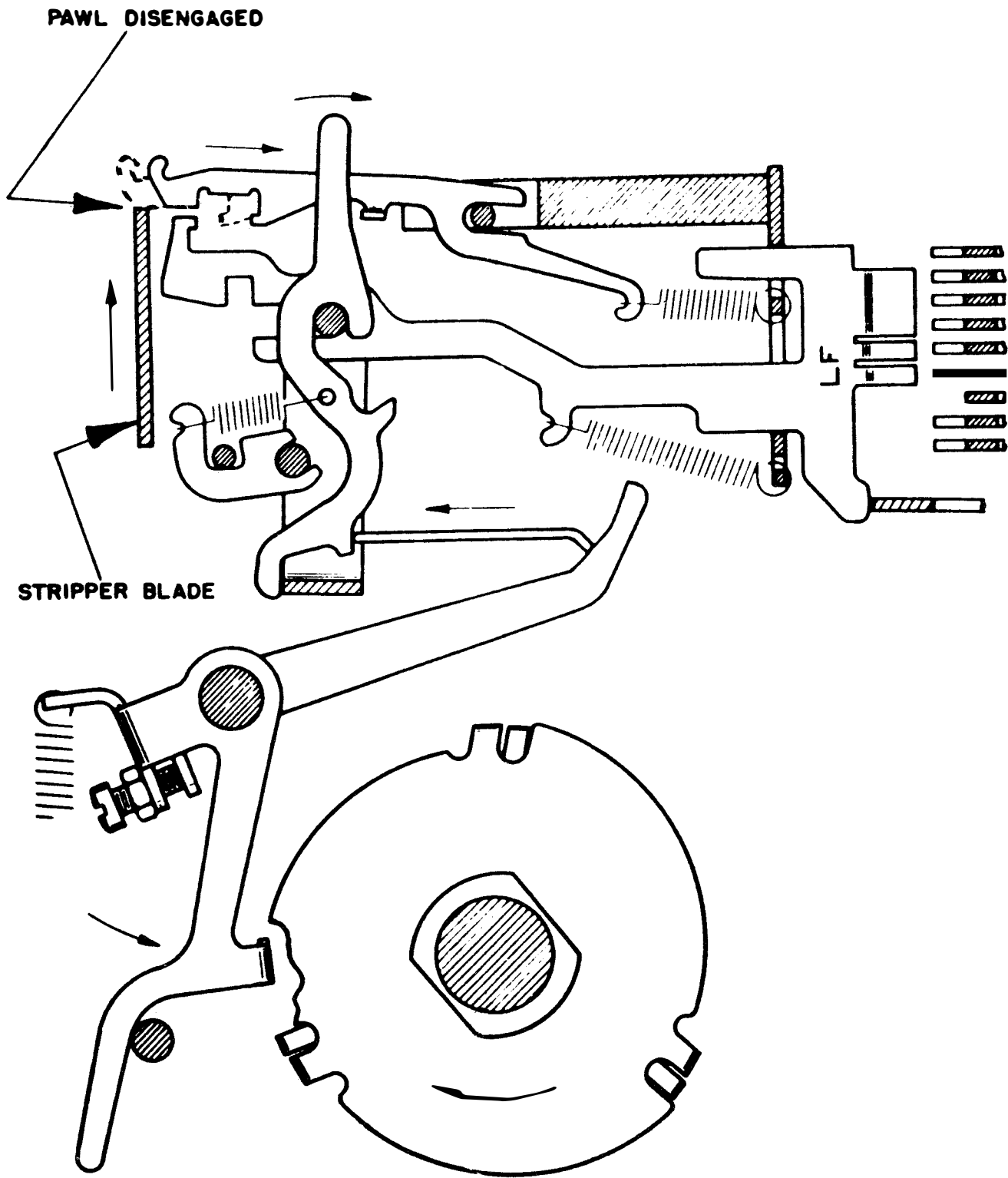

Figure 13 - Operation of a Printer Function

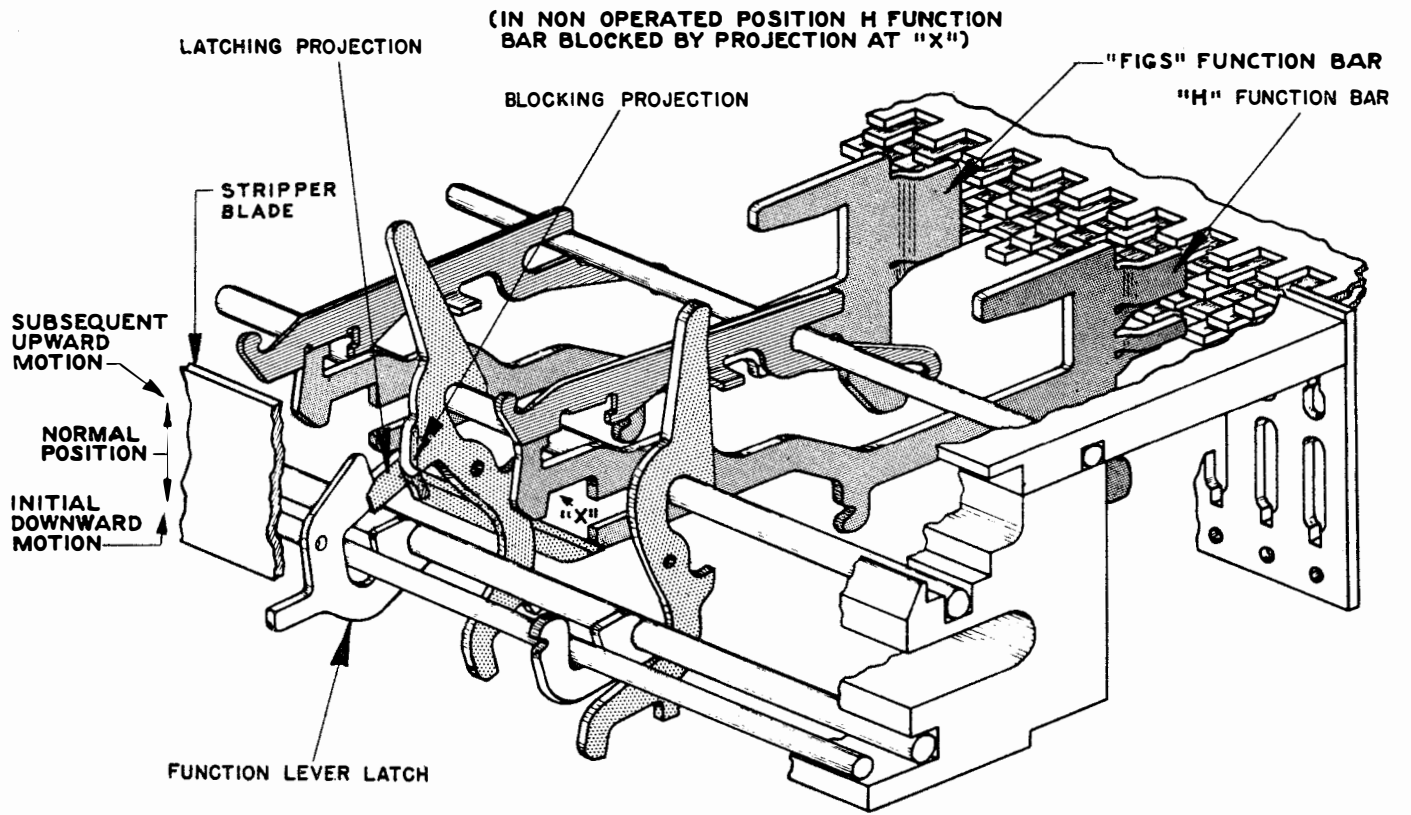

Figure 14 - Sequential Selection of a Function

LEGEND

- ⊗ MAKE CONTACT - MOMENTARY CLOSURE
- ⊕ BREAK CONTACT - MOMENTARY OPEN
- ⊗ LH - LATCHED CLOSED, RELEASED BY FIGS H
- ⊕ LBH - LATCHED OPEN, RELEASED BY FIGS BLANK H

NOTES:

1. STUNTBX PARTS FOR MOTOR CONTROL PROVIDED ONLY WHEN SPECIFIED.
2. POSSIBLE LOCATION OF OPTIONAL CONTACT BLOCK.

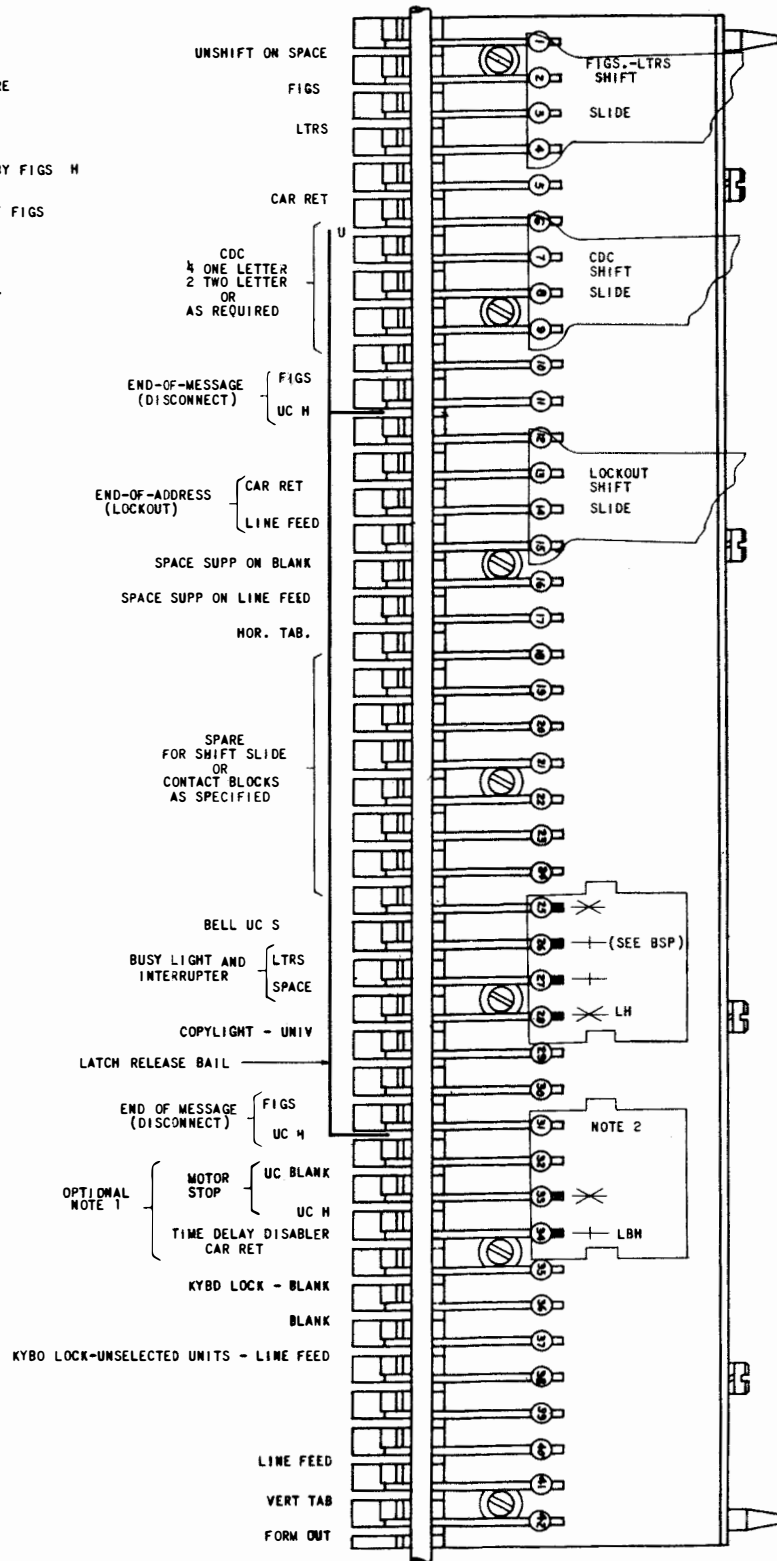

Figure 15 - Slot and Contact Arrangement - AN Stuntbox TP152810