

28 TYPING UNIT

DESCRIPTION AND PRINCIPLES OF OPERATION

CONTENTS	PAGE	CONTENTS	PAGE
1. GENERAL	2	7. POSITIONING THE CODE BARS . . .	17
2. DESCRIPTION	2	CODE BAR MECHANISM	17
GENERAL	2	CODE BAR OPERATION	18
MAIN SHAFT	4	CODE BAR ARRANGEMENT	19
SELECTING MECHANISM	5		
CODE BAR MECHANISM	5		
PRINTING MECHANISM	6		
SPACING MECHANISM	7		
LINE FEED MECHANISM	7		
STUNT BOX	7		
RIBBON FEED MECHANISM	7		
PAPER FEED MECHANISM	7		
3. TECHNICAL DATA	7		
APPROXIMATE DIMENSIONS	7		
SIGNAL REQUIREMENTS	7		
SIGNALING CODE	8		
4. GENERAL OUTLINE OF OPERATION	9		
5. DISTRIBUTION OF MOTION	10		
GENERAL	10	8. POSITIONING THE TYPE BOX	19
ONE STOP CLUTCHES	10	GENERAL	19
THREE STOP CLUTCHES	13	LETTERS-FIGURES SHIFT	20
6. SELECTION	13	VERTICAL POSITIONING	22
GENERAL	13	HORIZONTAL POSITIONING	23
SELECTOR MECHANISM	13	9. PRINTING	27
ORIENTATION	17	POSITIONING	27
		OPERATION	27

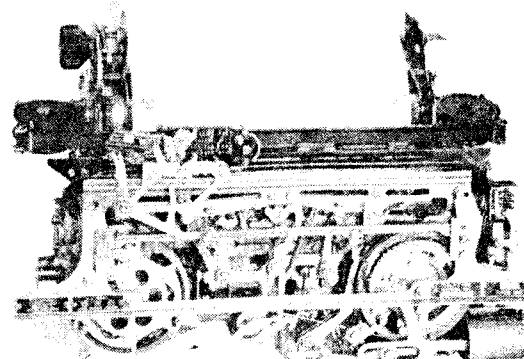

Figure 1 - 28 Typing Unit

CONTENTS	PAGE
10. SPACING	27
GENERAL	27
SPACE FUNCTION	29
SPACE SUPPRESSION	29
MARGIN INDICATOR	29
11. RIBBON FEEDING	30
DESCRIPTION	30
OPERATION	31
RIBBON REVERSING	31
12. PAPER FEEDING	31
13. STUNT BOX OPERATION	32
FUNCTIONS	32
CARRIAGE RETURN FUNCTION	36
LINE FEED FUNCTION	36
LETTERS-FIGURES SHIFT FUNCTION	41
STUNT BOX CONTACTS	41
14. SPROCKET FEED TYPING UNIT	42
GENERAL	42
DESCRIPTION	42
15. VARIABLE FEATURES	43
HORIZONTAL TABULATION	43
VERTICAL TABULATION AND FORM OUT	44
AUTOMATIC CARRIAGE RETURN-LINE FEED	47
LOCAL BACKSPACE	47
UNSHIFT ON SPACE	47
SIGNAL BELL	47

1. GENERAL

1.01 This section describes the basic Model 28 typing unit. There are two basic units: Friction feed which prints on single or multiple copy paper fed from a roll; and sprocket feed which prints on folded, form-feed paper with perforations to fit teeth on the platen. It also describes some variations to the basic units. It is reissued to correct photographs and line drawings.

1.02 Unless stated to the contrary, references in the text to "left" or "right" indicate the operator's right or left, facing the front of the unit, the selector mechanism at the right, and the type box at the front. In illustrations, unless specifically labeled otherwise, it is assumed that the equipment is being viewed from the front. Pivot points are shown in the drawings by circles or ellipses which are solid black to indicate fixed pivot points and crosshatched to indicate floating points.

1.03 With the main shaft under power (associated equipment main power supply on), the typing unit is described as running closed when a steady current (marking) condition is maintained in the signal line and no signal intelligence is received. It is described as running open when a no current (spacing) condition is maintained through an interruption in signal line current.

2. DESCRIPTION

GENERAL (Figs. 1 through 5)

2.01 The basic function of the 28 typing unit is to record in page printed form information received from a signal line in the form of a signaling code combination which represents characters or functions. The typing unit translates these electrical code combinations into mechanical motions which imprint the message or initiate the indicated function, such as line feed, carriage return, or signal bell. Printing is accomplished through an inked ribbon upon paper rolled around a horizontally stationary platen while the type and printing mechanism move from left to right across the page. All operations of the typing unit are performed automatically in response to input signal code combinations. A few local off-line functions such as line feed, or carriage return may be initiated

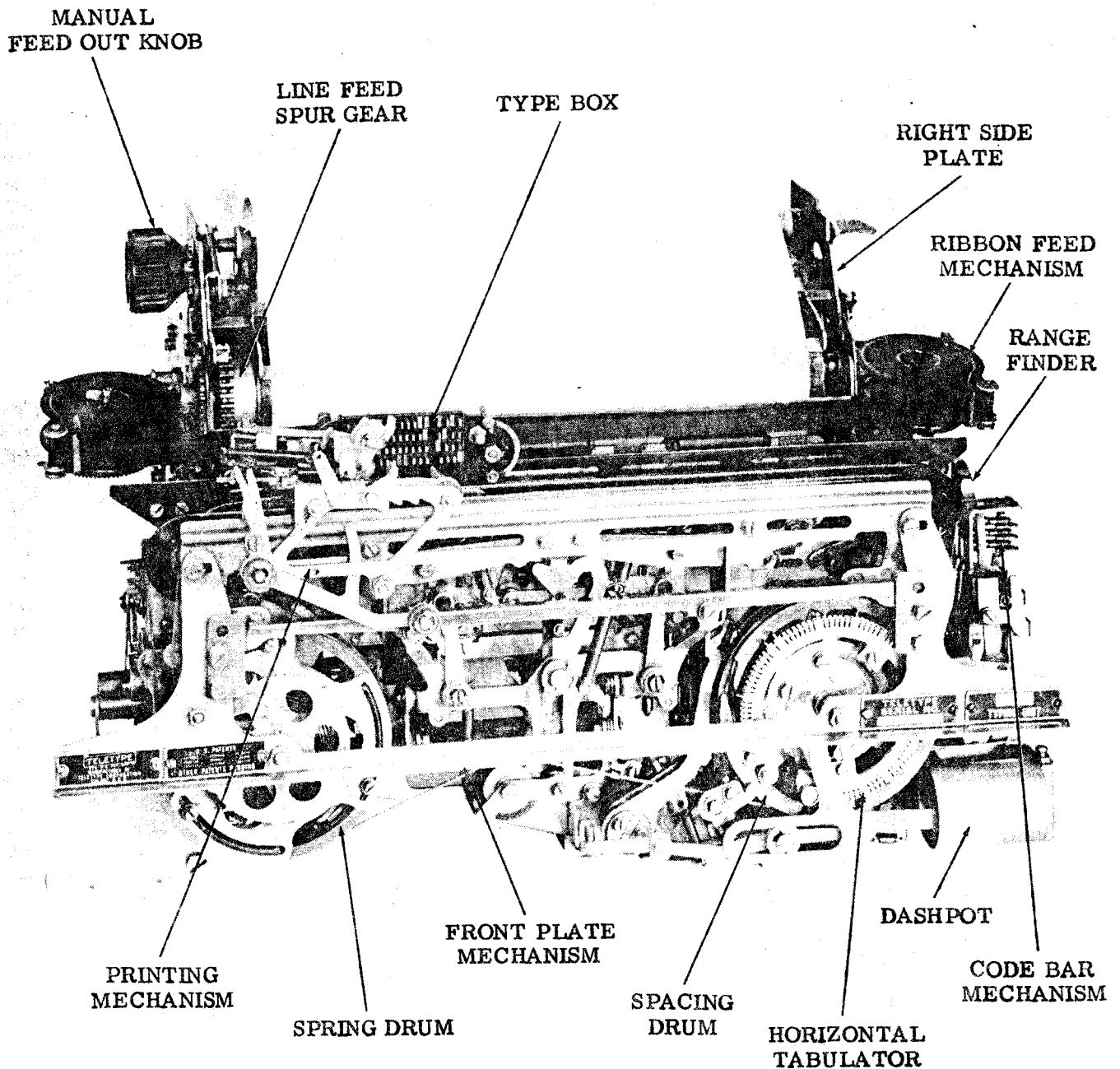

Figure 2 - 28 Typing Unit (Friction Feed) (Front View)

independently of the signal line from the local keyboard or base mechanism.

2.02 Character representations, or graphics, are the alphabetic, numeral or symbol intelligence equivalent of the input code combinations. Function representations are the coded equivalent of non-typing operations auxiliary to reception of the graphics, such as line feed, carriage return, or signal bell.

2.03 The speed of operation of the equipment is usually given in operations per minute. Speed in words per minute is roughly one-sixth of the operations per minute. The typing unit is designed to operate at 60, 75 or 100 words per minute, depending on the gear ratio used on associated equipment.

2.04 The typing unit is mounted on a receive-only base or a keyboard. Rotary mechanical motion for its operation and information

in the form of the signaling code come from external sources. A front plate and side plates provide mounting facilities for the various assemblies and mechanisms that make up the unit.

MAIN SHAFT

2.05 Motive power for operation of the typing unit is received through the intermediate gear mechanism of the base or keyboard base

on which the unit is mounted. Power is applied to the driven gear, centrally located on the main shaft at the rear of the typing unit. The main shaft rotates at a constant speed to operate the equipment at speeds of 60, 75 or 100 words per minute, depending upon external gear ratios.

2.06 Six all-steel internal expansion clutches convert the rotary motion of the main shaft to the linear mechanical requirements for

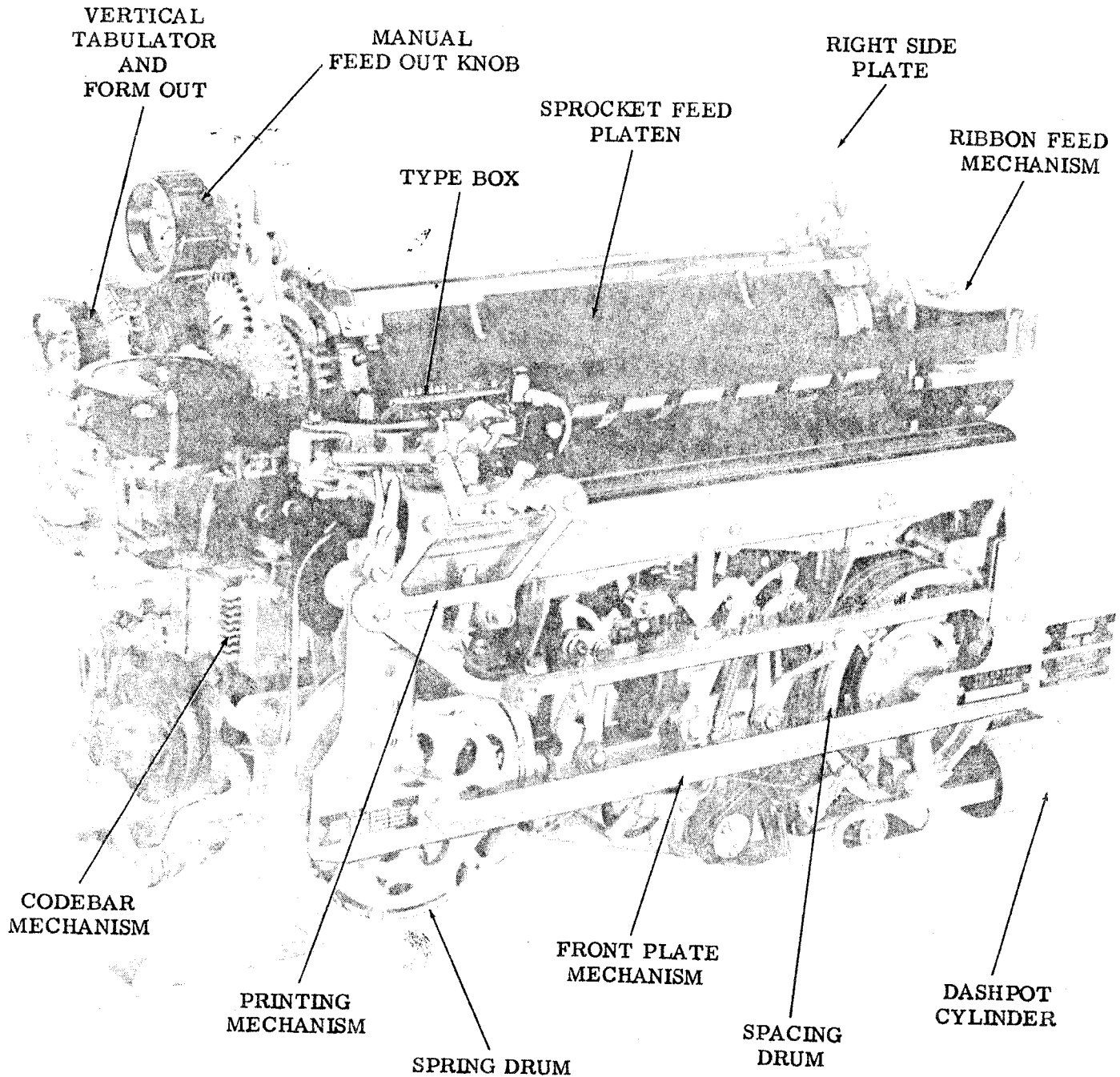

Figure 3 - 28 Typing Unit (Sprocket Feed) (Left Front View)

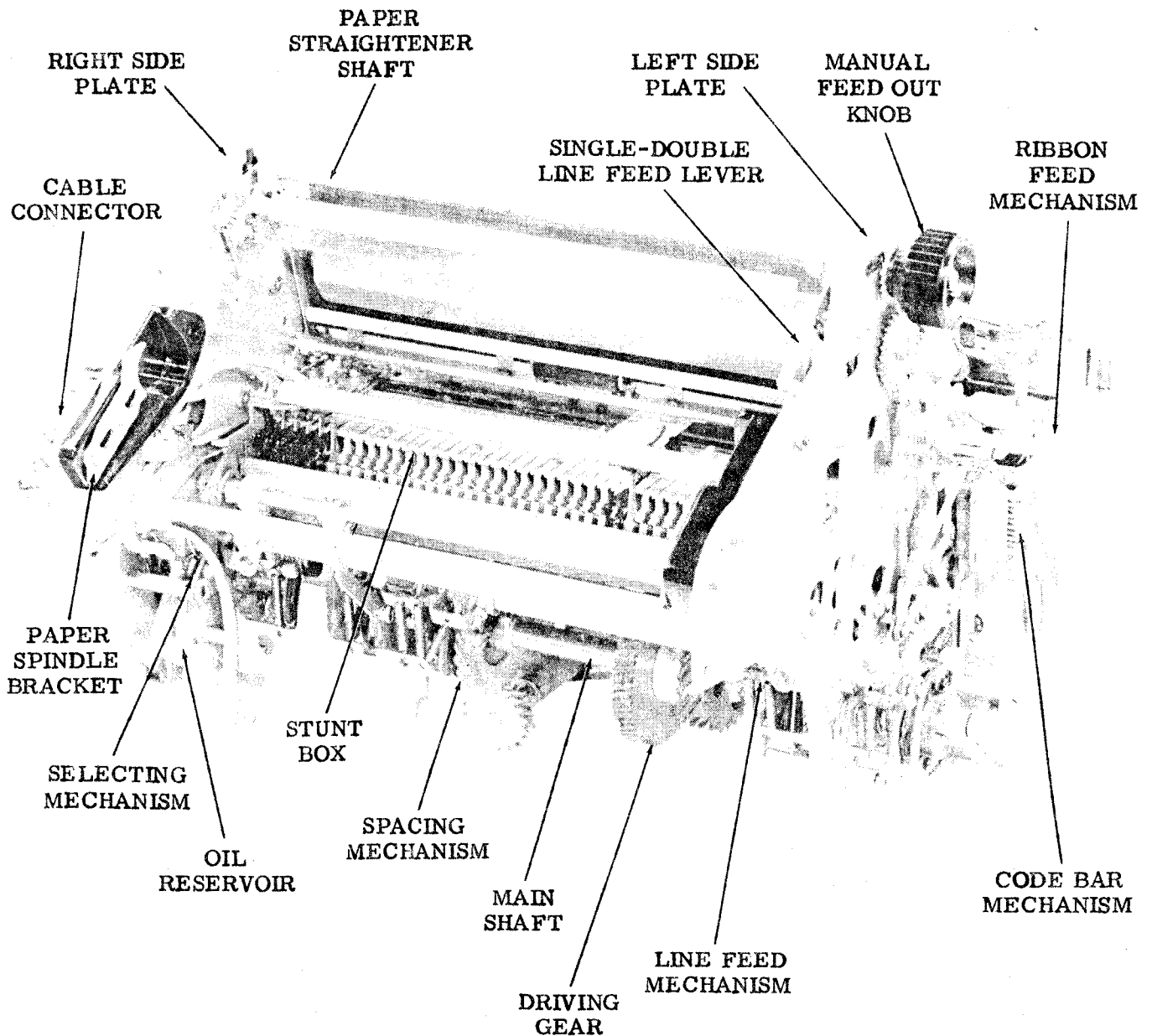

Figure 4 - 28 Typing Unit (Left Rear View)

operation of the printer. The clutches rotate with the main shaft when engaged and do not rotate when disengaged (latched). From left to right in their installed position on the main shaft, the clutches control the type box, line feed, spacing, function, code bar and selecting mechanisms, respectively.

SELECTING MECHANISM

2.07 A selecting mechanism translates the signaling code combinations into corresponding mechanical arrangements which control

the code bars. It includes a two-coil magnet that connects in series with the external signal line. The coils may be wired in either series or parallel to accommodate 0.020 ampere or 0.060 ampere line currents. A range finder is used to refine the mechanical orientation of the selector to the signaling code.

CODE BAR MECHANISM

2.08 The code bar mechanism, when positioned by the selecting mechanism to correspond to the input code intelligence, sets up mechanical

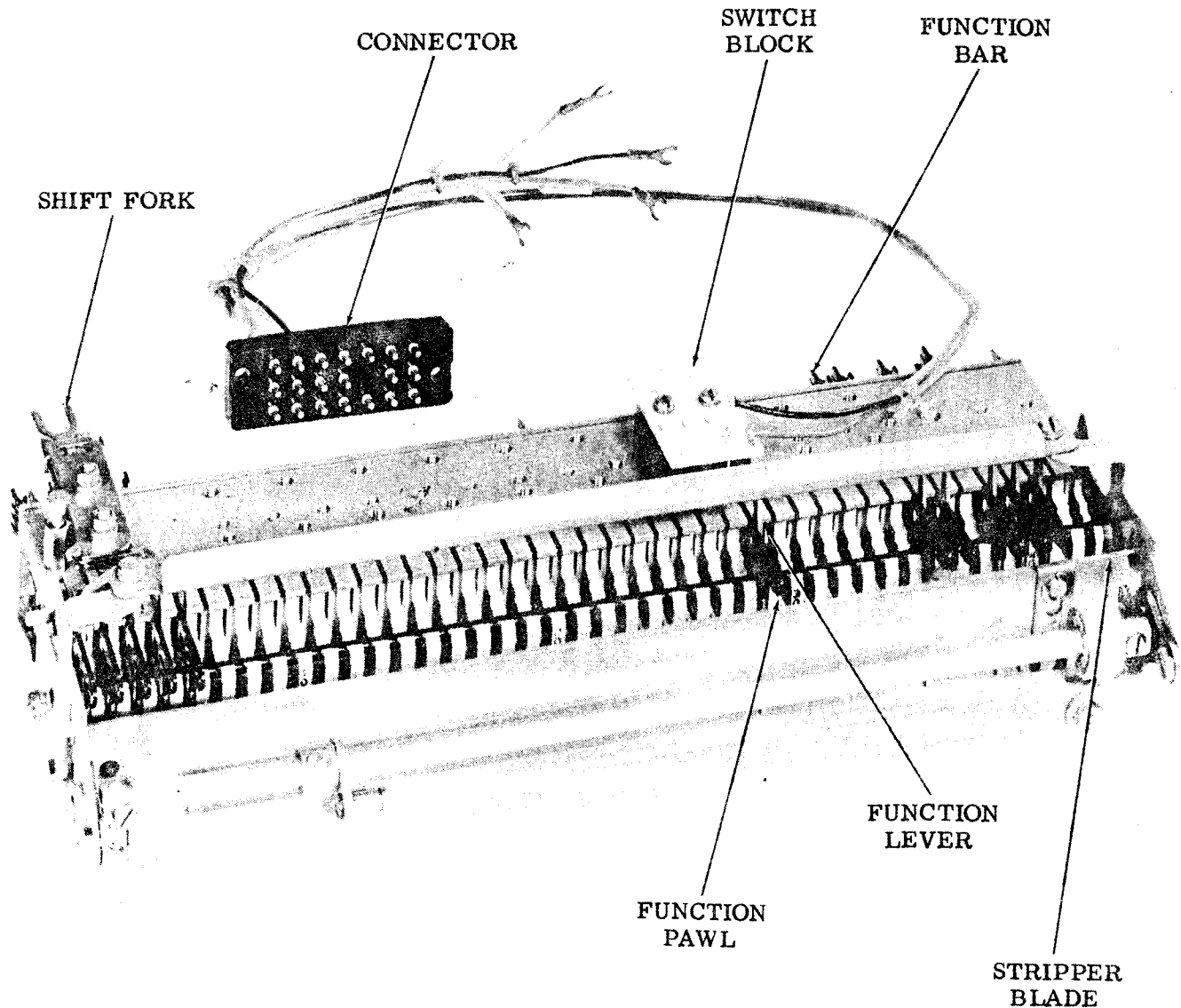

Figure 5 - Stunt Box (Rear View)

requirements for type box positioning, printing and stunt box operation.

PRINTING MECHANISM

2.09 When mechanically conditioned by the code bar mechanism, the printing mechanism prints the selected character and spaces

to the next printing area on the paper, or spaces without printing, or on units so equipped, tabulates horizontally, or returns the type box to the left hand printing margin. The mechanism includes horizontal positioning mechanism operated by the code bars, spacing mechanisms and carriage return, and the print hammer mechanism.

2.10 The type box is capable of vertical and horizontal positioning in response to the permutations set up by the code bar mechanism. When positioned to correspond to the input code intelligence, the type box presents a single type pallet with the embossed graphic equivalent of the selected code for printing. Printing is accomplished when this pallet is struck by the print hammer to press an inked ribbon against the paper, which is supported by the typing unit platen.

SPACING MECHANISM

2.11 The spacing mechanism moves the type box and printing mechanism one character to the right each time a graphic character is received and imprinted. A suppression mechanism prevents spacing on receipt of certain non-typing functions. On sprocket feed typing units, the spacing mechanism may be adapted to the page to predetermined stop positions.

LINE FEED MECHANISM

2.12 The line feed mechanism permits single or double line advance of paper in the platen mechanism when the code combination for this function is received. The function may also be initiated locally through mechanical linkage with the base or keyboard base. On sprocket feed typing units, the line feed mechanism may be adapted to vertical tabulation and to rapid form feed out.

STUNT BOX (Fig. 5)

2.13 The stunt box is a compact, self-contained device with memory storage capabilities that provides the typing unit with the facilities of a built-in sequence selector. In effect, it allows the 32 available letters and figures character combinations to be used again for special, non-printing operations, without the sacrifice of printed characters. It operates in response to combinations set up in the code bar mechanism with a single character or several characters in sequential combination used to initiate a single function. In general, the stunt box may be programmed to perform three basic types of operation: mechanical initiation of internal functions within the typing unit; electrical control of functions within the Teletypewriter Set; and electrical control of external equipment.

RIBBON FEED MECHANISM

2.14 A ribbon feed mechanism passes an inked fabric ribbon between the type box and the paper. The mechanism advances the ribbon

horizontally when each character has been printed and automatically reverses the direction of ribbon feed when one of the two ribbon spools has been emptied.

PAPER FEED MECHANISM

2.15 The platen and paper feed mechanisms are located at the top of the printer, between the two side plates. A manual paper or form feed out knob is located at the top of the left side plate. Paper is fed from a supply at the rear of the printer either by friction feed or on sprockets located on the ends of the platen.

3. TECHNICAL DATA

APPROXIMATE DIMENSIONS

Width	15-1/4 inches
Depth	10 inches
Height	9-3/4 inches
Weight	
Friction Feed	19 pounds
Sprocket Feed	22 pounds

SIGNAL REQUIREMENTS

Code	Sequential, 7.42 unit, Start-Stop
Current	
Selector coils in series	0.020 amperes
Selector coils in parallel	0.060 amperes

3.01 All electrical requirements for operation of the 28 typing unit are supplied through associated equipment, such as a base, keyboard base or electrical service unit. All electrical connections to the typing unit are made through a cable connector, mounted just above the selecting mechanism on the right side (Fig. 3).

3.02 The selector magnets may be operated with 0.020 ampere (coils in series) or 0.060 ampere (coils in parallel) dc signal line current. Signal-line inputs of the neutral form (non-polar) may be applied directly to the selector magnets. Polar signals require the use of a line relay.

3.03 Electrical contacts for certain variable features, such as the paper out alarm and the form out alarm, horizontal tabulator, vertical tabulator and form out generally require 115 vac circuitry. The circuits to stunt box switching contacts are determined by the specific nature of external controls operated by the contacts.

SIGNALING CODE (Fig. 6)

3.04 Information is received by the typing unit in the form of a 7.42 unit start-stop signaling code in which each character (graphic) or function is represented by a sequential combination of current and no-current time intervals. Intervals during which current flows in the signal circuit are referred to as marking and those in which no current flows are spacing. Every combination includes five pulses (also referred to as levels) that carry the intelligence, each of which may be either marking or spacing. To insure synchronization between the transmitting and receiving equipment, a start pulse which is always spacing is added at the beginning of each combination of intelligence pulses, and a stop pulse which is always marking is added at the end.

3.05 The code representation for the graphics R and Y are illustrated in Figure 7. In these combinations, alternate marking and spacing conditions for the intelligence pulses are required.

3.06 In different signaling codes used with 28 teletypewriter equipment, the length of the stop pulse may vary. For example, in the code illustrated in Figure 6, the length of the stop pulse is 1.42 times the other pulses. Thus, the transmission of a graphic requires 7.42 units of time. It is therefore said to have a 7.42 unit transmission pattern. The stop pulse may be equal in duration to the other pulses in some applications, in which case the transmission code would have a 7.0 unit transmission pattern.

3.07 The total number of permutations of a five level (5 intelligence pulses) code is two to the fifth power, or 32. To accommodate more than 32 graphics, a letters-figures shift is designed into the typing unit. This is similar to the lower and upper case of a typewriter and permits each code combination, excluding the two used to shift the equipment, to represent two characters.

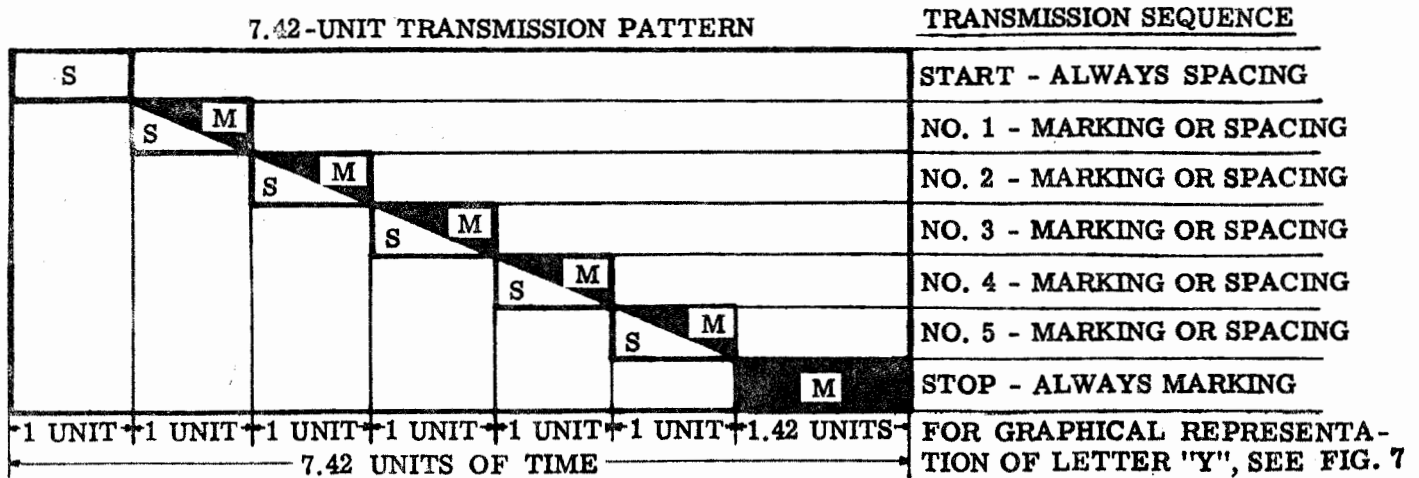

a.

FIGURES	-	?	:	\$	3	!	&	#	8	'	()	.	,	9	ø	l	4	Δ	5	7	;	2	/	6	"	z	<	≡	■	V	Λ		
LETTERS	A	B	C	D	E	F	G	H	I	J	K	L	M	N	O	P	Q	R	S	T	U	V	W	X	Y	Z	BLANK	C.R.	L.F.	SPACE	LTR	FIG.		
1	●	●		●	●	●				●	●									●	●	●	●	●	●	●						●	●	
2	●		●				●		●	●	●	●			●	●	●				●	●	●	●					●				●	●
FEED HOLES	○	○	○	○	○	○	○	○	○	○	○	○	○	○	○	○	○	○	○	○	○	○	○	○	○	○	○	○	○	○	○	○	○	○
3			●		●		●	●	●	●	●	●	●	●	●	●	●	●	●	●	●	●	●	●	●	●						●	●	
4		●	●	●		●	●		●	●	●	●	●	●	●	●	●	●	●	●	●	●	●	●	●	●						●	●	
5		●					●	●				●	●	●	●	●	●	●	●	●	●	●	●	●	●	●						●	●	

(TYPICAL CHARACTER ARRANGEMENT) b.

Figure 6 - Signaling Code

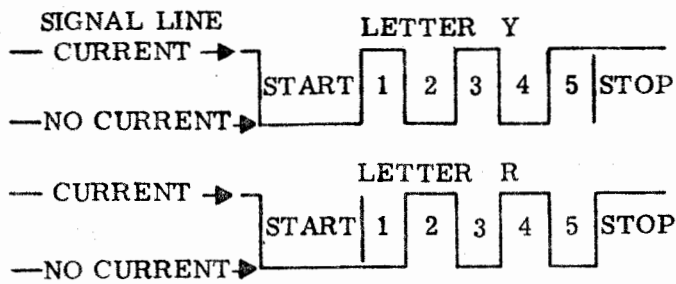

Figure 7 - Code Representation of R and Y

3.08 A typical character arrangement is shown on the chart of Figure 6. The black circles represent marking pulses, the blank squares spacing pulses. When the letters code combination (12345) is transmitted, it conditions all typing units connected to the circuit to print, at the receipt of all following code combinations, the characters in the letters (lower case) line on the chart. Similarly, when the figures code combination (12-45) is transmitted, it conditions the typing units to print the character or perform functions in the figure (upper case) line on the chart.

4. GENERAL OUTLINE OF OPERATION

4.01 The friction feed typing unit (Fig. 2) and the sprocket feed typing unit (Fig. 3) are essentially identical, except for differences in the paper feeding mechanisms. The following description of operation applies to both units, with the difference covered in par. 12 (friction feed) and par. 14 (sprocket feed).

4.02 The relationship of the operating mechanisms of the 28 typing unit are illustrated in the block diagram (Fig. 8). Rotary motion from the intermediate gear mechanism of an associated base or keyboard base is applied to the main shaft, which turns constantly as long as the associated unit is under power. A signal applied to the selector magnets initiates operating sequences. The application of voltage to the stunt box and to various switches and controls is dependent upon external circuitry and associated equipment.

4.03 The signaling code combinations are applied to the selecting mechanism through a cable connector located just above the selector

magnets. The start pulse (spacing) of each code combination permits the start lever to fall to the rear behind the magnet armature and rotate to trip the selector cam clutch. The range finder mechanism permits adjustment of the angular relationship of the trip-off point to the optimum quality incoming line signal.

4.04 The selector cam clutch, driven by the main shaft, as are all clutches, converts the incoming signal into mechanical marking or spacing equivalents of each pulse in the signal code. A cam on the selector cam clutch engages the code bar clutch when a signal code combination has been translated and locked in a mechanical arrangement in the selecting mechanism.

4.05 The code bar clutch initiates mechanical actions which position the code bars in patterns determined by the selecting mechanism (marking-left, spacing-right), and condition the typing unit for type box positioning, function selection and printing. A cam operated by the code bar clutch operates the function clutch and type box clutch trip mechanisms.

4.06 The function clutch controls the function bail and the stripper bail. The function reset bail permits transfer of intelligence from the code bars to the function mechanism and, upon receipt of a function code, operates the function linkage or switch or contact corresponding to the input signal code. The stripper bail resets selected function mechanisms. When the input signal calls for carriage return function, direct mechanical linkage between the stunt box and the spacing mechanism initiates this function. When the input signal calls for line feed, the function mechanism trips the line feed mechanism, engaging the line feed clutch.

4.07 The line feed clutch operates mechanical linkages which advance the paper one or two spaces by rotating the platen. On units so equipped, the page feed out mechanism also operates the line feed clutch trip mechanism.

4.08 The code bar mechanism (4.04) and the code bar clutch operate in combination to trip the type box clutch. When the type box clutch is tripped, it initiates mechanisms involved in vertical positioning of the type box, horizontal type box positioning, ribbon feed and printing. The main rocker bail provides power from the type box clutch (and main shaft), and the code bars determine the specific application of that power required for each input signal code combination representing a graphic. A cam plate on the main rocker bail trips the spacing

clutch stop mechanism to engage the spacing clutch, except when spacing is suppressed.

4.09 The spacing clutch, when tripped by the cam plate on the printing mechanism main rocker ball, advances the type box and printing hammer one character space to the right across the paper. Spacing suppression may be initiated by the function mechanism, to permit execution of a non-typing function without interference with the page printed message by the carriage return mechanism or by the printing mechanism when the type box reaches the end of a printed line.

4.10 The type box, positioned by the printing and spacing mechanisms in accordance with intelligence set up in the code bars, presents a single graphic in printing position for each operating cycle. To prevent printing during a function selection, the type box is positioned to present a vacant type-pallet position. At the proper moment, with the type box locked in printing position, a spring loaded print hammer is released to tap the selected type pallet sharply against the inked ribbon and the paper. A cleanly imprinted graphic character corresponding to the input signal code combination results, and the printing mechanism trips the spacing clutch to move both the type box and the print hammer to the next horizontal printing position to the right.

5. DISTRIBUTION OF MOTION (Fig. 9)

GENERAL

5.01 The main shaft is located in the lower rear portion of the typing unit, supported between the two side frames by ball bearings. It extends the full width of the unit.

5.02 Centrally located on the shaft are two driving gears. The larger gear meshes with the intermediate gear mechanism of the associated base or keyboard base to transmit power from the motor to the typing unit. The smaller gear drives the signal generator mechanism of an associated keyboard base.

5.03 Power take-off from the constantly rotating main shaft is controlled by six clutches, each of which, when tripped (engaged, or unlatched) drives its associated mechanism. From the right end of the shaft, these clutches may be identified as the selector clutch (with cam sleeve), the code bar clutch, the function clutch, the spacing clutch, the line feed clutch

and the type box clutch. The sequence in which these clutches are tripped is, selector, code bar, function, type box, spacing and line feed. However, the type box and spacing clutch engagement may be suppressed under certain operating conditions, and the line feed clutch is operative only upon a specific set of input signal code combinations.

5.04 The spacing and line feed clutches are three stop clutches (Fig. 10), each permitting their associated mechanism to operate through one-third of a revolution of the main shaft. All other clutches are one stop clutches (Figs. 11 and 12), operating through an entire revolution of the main shaft.

ONE STOP CLUTCHES (Figs. 11 and 12)

5.05 The clutch drums are attached to and rotate with the main shaft (Fig. 9). In the disengaged position, as shown in Fig. 11, the clutch shoes do not contact the drum, and the shoes and cam disk are held stationary. Engagement is accomplished by moving the stop arm (Fig. 12) toward the rear of the typing unit, away from the clutch, thus releasing stop lug A and the lower end of shoe lever B (Fig. 12). The upper end of lever B pivots about its ear C, which bears against the upper end of the secondary shoe and moves its ear D and the upper end of the primary shoe toward the left until the shoe makes contact with the notched inner surface of the rotating drum at point E. As the drum turns counterclockwise, it drives the primary shoe downward so that it again makes contact with the drum at point F. There, the combined forces acting on the primary shoe cause it to push against the secondary shoe at point G. The lower end of the secondary shoe then bears against the drum at point I. The forces involved are multiplied at each of the preceding steps. The aggregate force is applied through the shoes to the lug J on the clutch cam disk, and the disk and attached cam turn in unison with the drum.

5.06 Disengagement is effected when the lower end of shoe lever B strikes the stop arm. Lug A and the lower end of the shoe lever are brought together (Fig. 11), and the upper end of lever B pivots about its ear C and allows its other ear D to move toward the right. The upper spring then pulls the two shoes together and away from the drum. The latch lever seats in the indent in the cam disk, and the cam is held in its stop position until the clutch is again engaged.

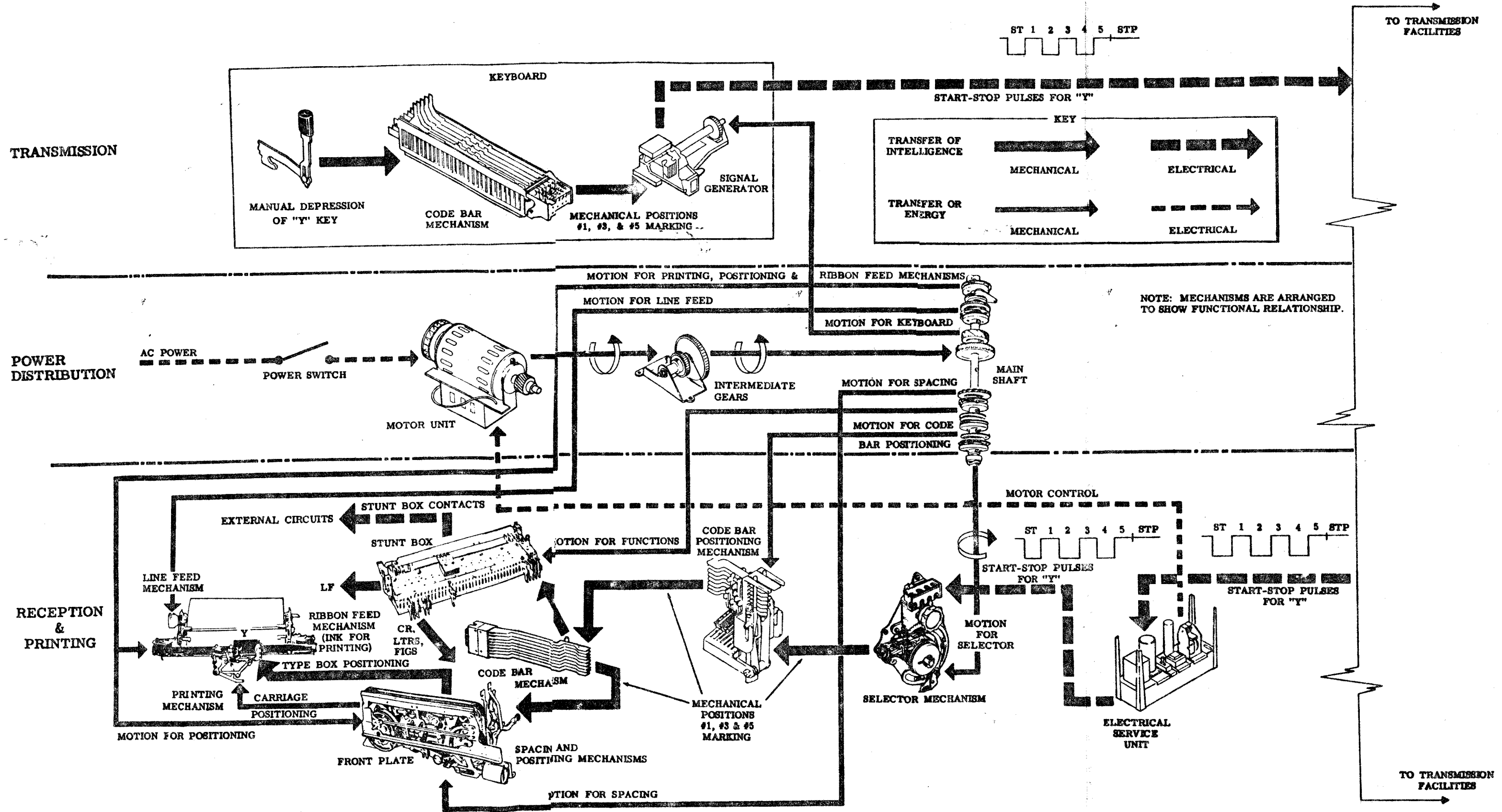

Figure 8 - 28 Typing Unit, Schematic Diagram

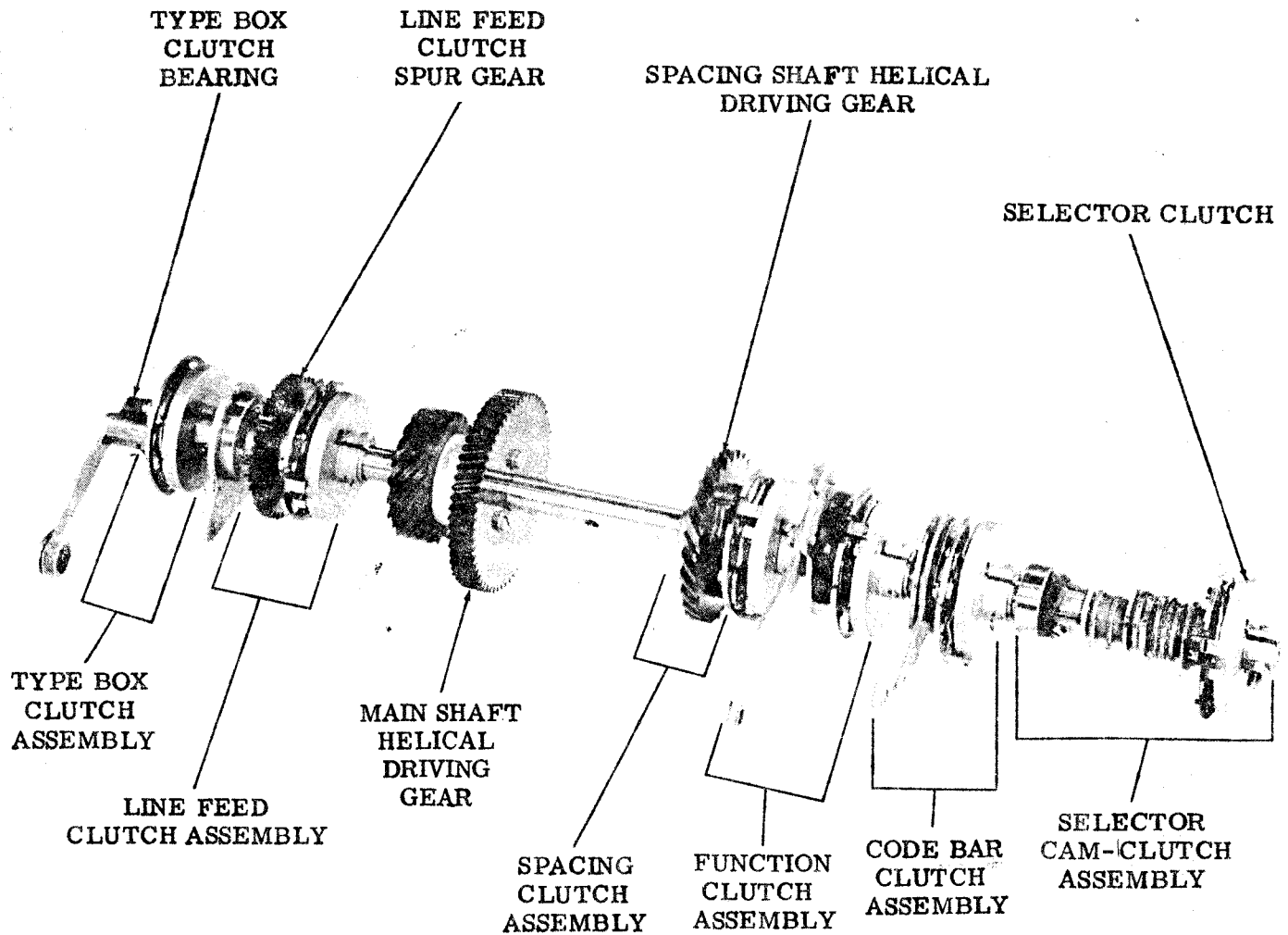

Figure 9 - Main Shaft (Right Front View)

THREE STOP CLUTCHES (Fig. 10)

5.07 Two of the clutches, spacing and line feed, have three sets of lugs equally spaced about their periphery. The action is as described in 5.05-5.06, but the clutch is permitted to rotate through only one-third revolution before the stop lever and latch lever halt its motion.

6. SELECTION

GENERAL

6.01 The selecting mechanism consists of two magnet coils, an armature, a selector cam clutch, and the associated levers, arms,

bails and slides necessary to convert the electrical pulses of the start-stop code to the mechanical arrangements which govern the character to be printed and the function to be performed.

SELECTOR MECHANISM (Figs. 9, 13 and 14)

6.02 The selector cam clutch comprises, from right to left (Fig. 9) the clutch, the stop arm bail cam, the fifth, fourth, and the third selector lever cams, the cam for spacing and marking lock levers, the second and first selector lever reset ball cam, and the code bar clutch trip cam.

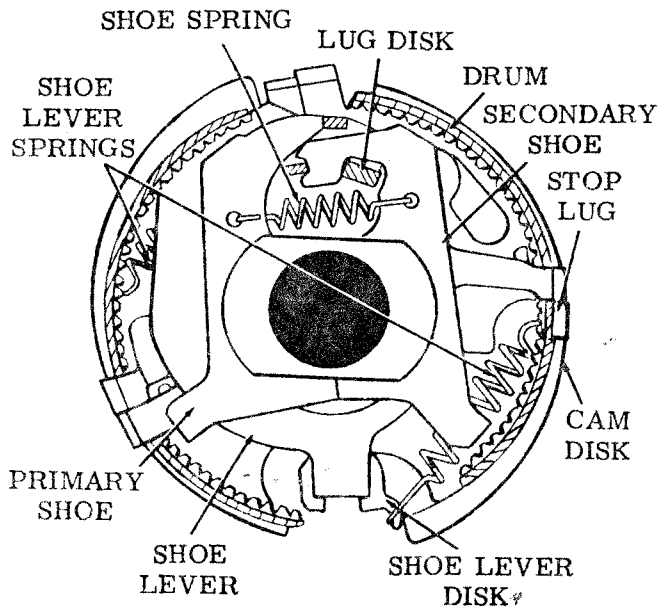

Figure 10 - Three Stop Clutch

6.03 During the time in which a closed line circuit (marking) condition exists, the selector magnet coils are energized and hold the selector armature against the selector magnet pole pieces. In this stop position, the selector armature blocks the start lever (Fig. 13). While the signal for any character or function

is being received, the start (spacing) pulse releases the selector armature which, under the tension of its spring, moves away from the magnet cores, and thus unlatches the start lever. The start lever rotates clockwise (as viewed from the right) under tension of its spring, moving the stop arm bail into the indent of the first cam. As the stop arm bail rotates about its pivot point, the attached stop arm is moved out of engagement with the clutch shoe lever. The selector cam clutch engages and begins to rotate. The stop arm bail immediately rides to the high part of its cam, where it remains to hold the start lever away from the selector armature during the reception of the signal code combination. When the stop pulse at the end of the signal code combination is received, the selector armature is pulled up to block the start lever. Thus, the stop arm bail is prevented from dropping into the indent of its cam, and the attached stop arm is held so as to stop the clutch shoe lever. The clutch cam disk upon which the latch lever rides has an indent as its stop position. When the clutch shoe lever strikes the stop arm, the inertia of the cam disk assembly causes it to continue to turn until its lug makes contact with the lug on the clutch shoe lever. At this point, the latch lever drops into the indent in the cam disk, and the clutch is held disengaged until the next start bit is received.

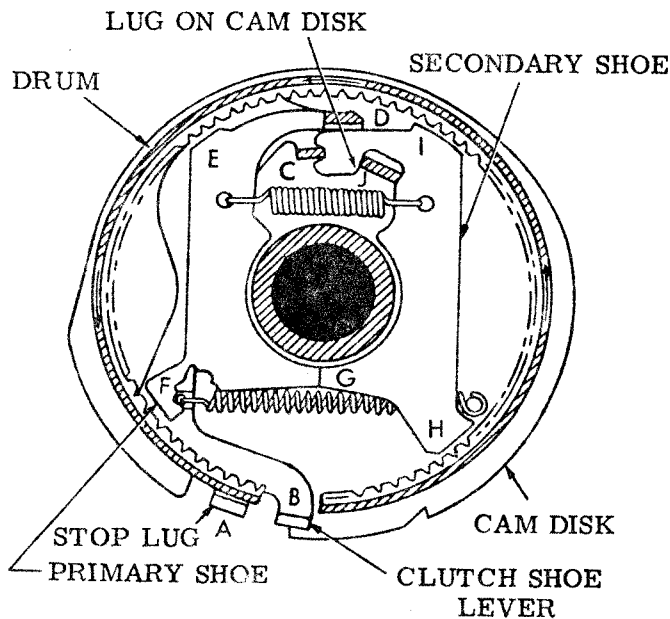

Figure 11 - One Stop Clutch (Disengaged)

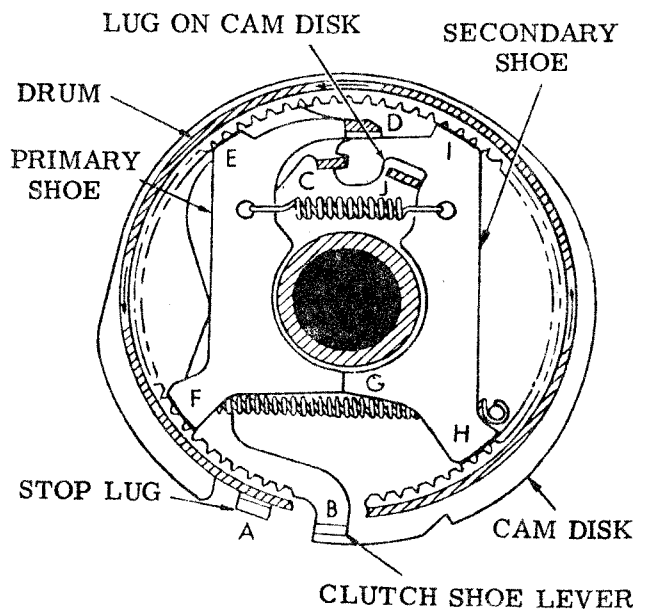

Figure 12 - One Stop Clutch (Engaged)

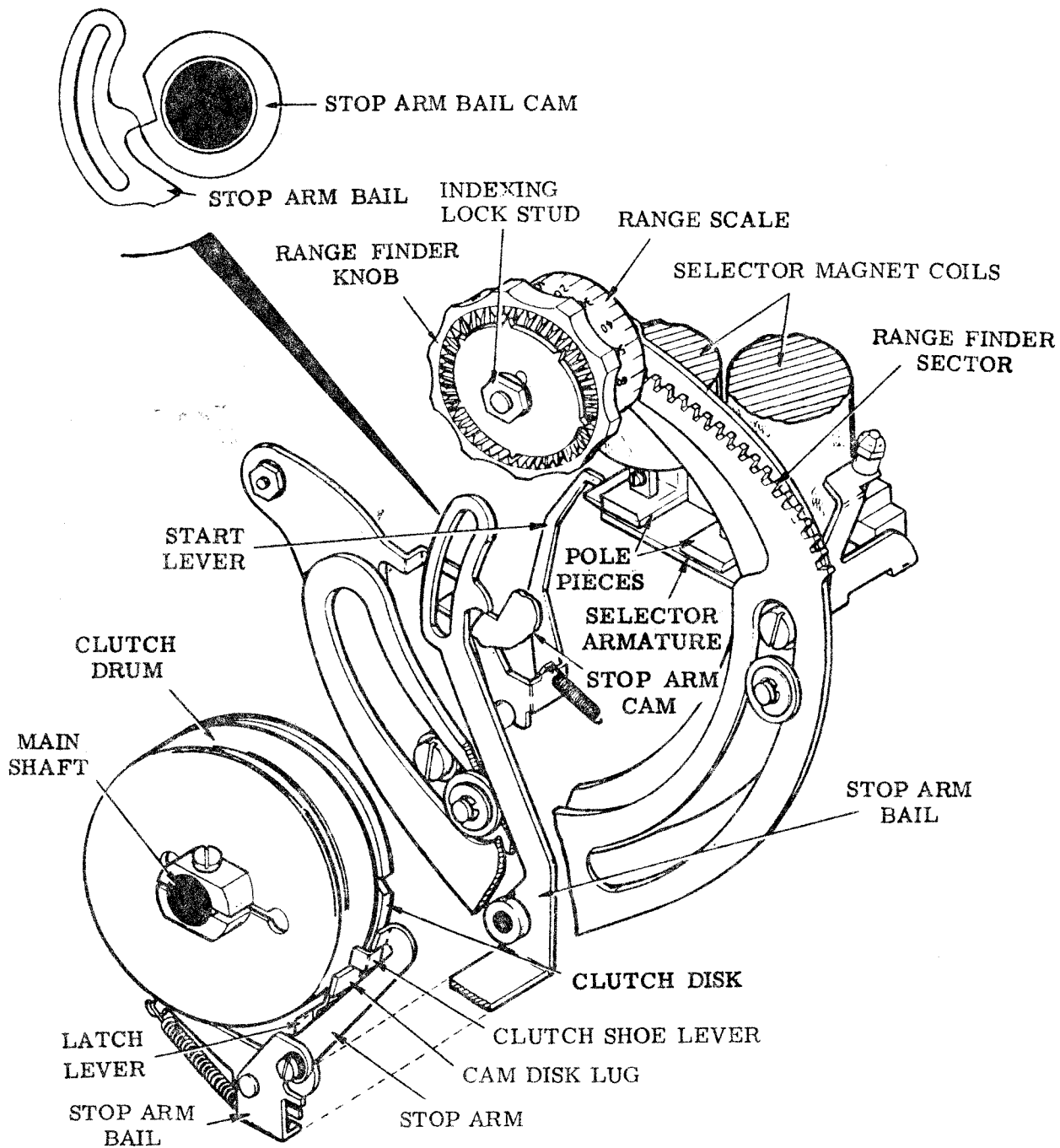

Figure 13 - Selector Clutch and Range Finder (Right Front View)

6.04 The series of five selecting levers and a marking lock lever ride their respective cams on the selector cam clutch. As the marking or spacing signal pulses are applied to the selector magnets, the selector cam clutch rotates and actuates the selector levers. When a spacing pulse is received, the marking lock lever is blocked by the end of the armature, and

the spacing lock lever swings toward the rear, above the armature, and locks it in the spacing position until the next signal pulse is received. Extensions on the marking lock lever prevent the selector levers from following their cams (Fig. 14). When a marking pulse is received, the spacing lock lever is blocked by the end of the armature, and the marking lock lever swings

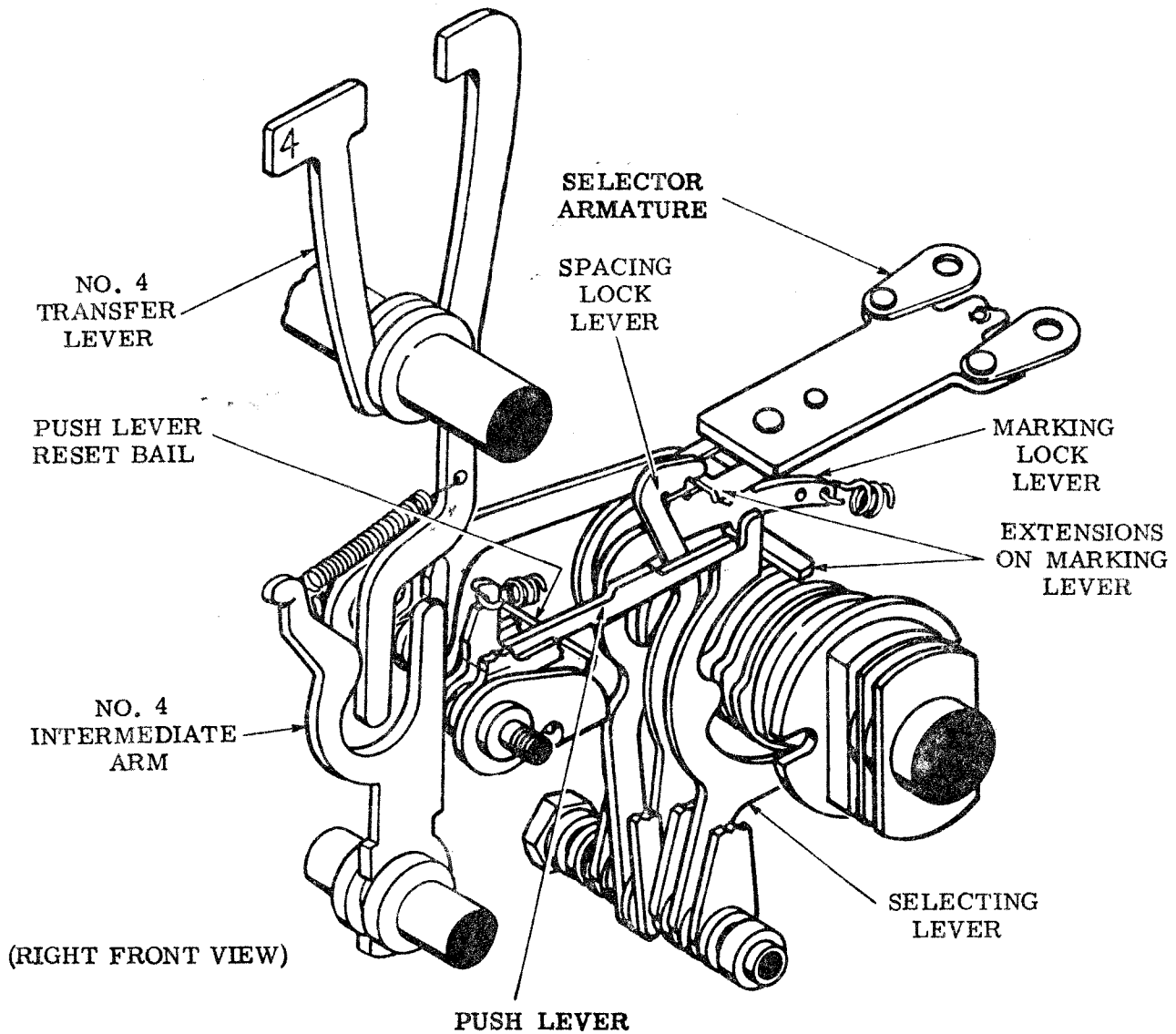

Figure 14 - Selecting Mechanism and Transfer Mechanism

to the rear, below the armature, to lock it in the marking position until the next signal pulse is received. During this marking condition, the selector levers are not blocked by the marking lock lever and are permitted to move against their respective cams. The selecting lever that is opposite the indent in its cam while the armature is locked in marking condition swings to the rear, or selected, position momentarily.

6.05 Each selecting lever has an associated push lever which drops into a notch on the top of the selecting lever when the selecting lever falls into the indent in its cam. As the

selector cam clutch rotates, each selecting lever is moved forward as it rides to the high part of its cam. Selected (dropped) push bars are also moved forward. Unselected push bars remain in the rear position, on top of the notch of the selecting lever. When all five code pulses have been received, push levers are held in their selected or unselected position until the next start bit is received.

6.06 When the subsequent start pulse is received, the cam clutch is again engaged. The push lever reset bail, following its cam, unlatches the selected push levers. The push

levers then return to their unselected (rear) position under their spring tension.

ORIENTATION

6.07 For optimum performance, the selecting mechanism should sample the code elements at the most favorable time. Manual operation of the range finder varies the time of sampling between the operating margins. Adjusting the range finder is called orientation.

6.08 When the range finder knob (Fig. 13) is pushed inward and rotated, its attached range finder gear moves the range finder sector (which mounts the stop arm bail, stop arm and latch lever) either clockwise or counterclockwise about the selector cam clutch. This changes

the angular position at which the selector cam clutch stops with respect to the selecting levers. When an optimum setting is obtained, the range finder knob is released. Its inner teeth engage the teeth of the indexing lock stud to lock the range finder mechanism in position. The setting may be read on the range finder scale opposite the fixed index mark.

7. POSITIONING THE CODE BARS

CODE BAR MECHANISM (Fig. 15)

7.01 The character printed or the function performed by the typing unit is basically determined by the code bar mechanism, to which the input signal intelligence, translated into mechanical form, is transmitted from the

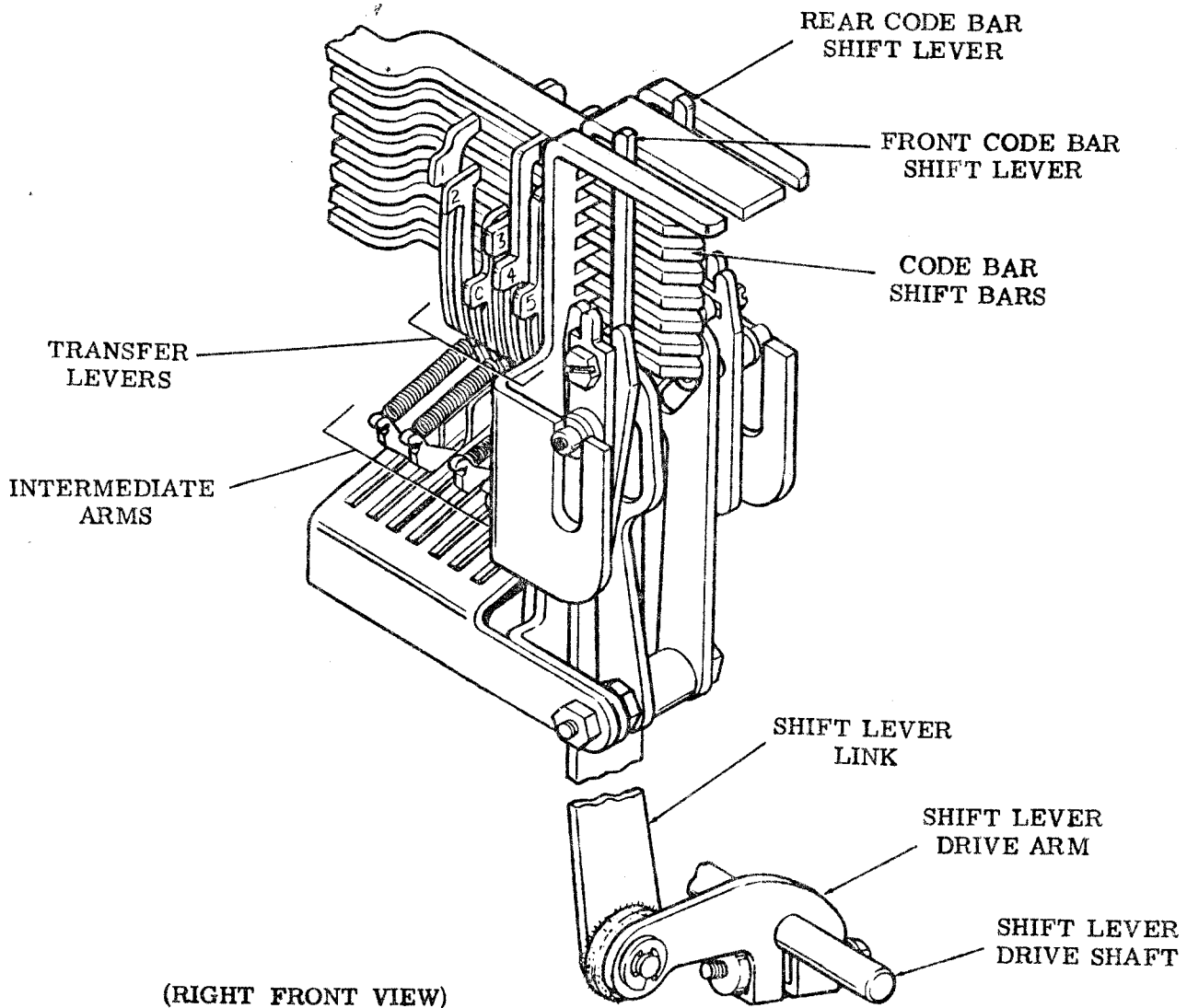

Figure 15 - Code Bar Mechanism

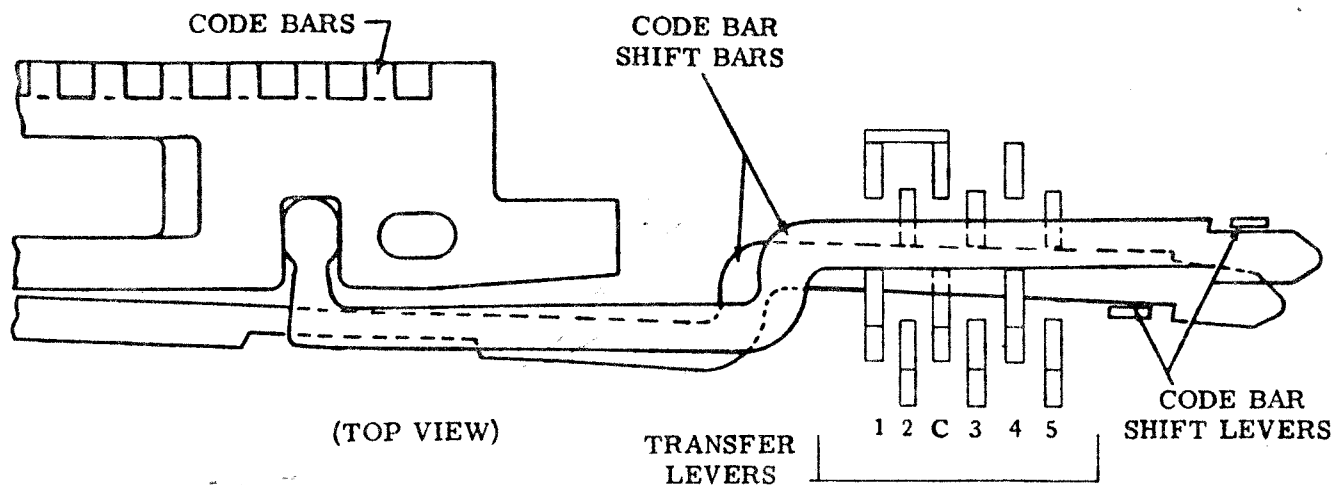

Figure 16 - Code Bar Shift Bar Positioning

selecting mechanism push bars. The code bars are positioned by code bar shift bars which move to the left for marking and to the right for spacing. The shift bars, positioned to the rear for marking and forward for spacing, are pushed into marking position by selected push bars through a mechanical linkage intermediate arms and transfer levers.

7.02 Power to position the selected code bar levers, and through them the code bars, is supplied by the code bar clutch. The code bar clutch is engaged by its cam on the selector cam clutch (6.02).

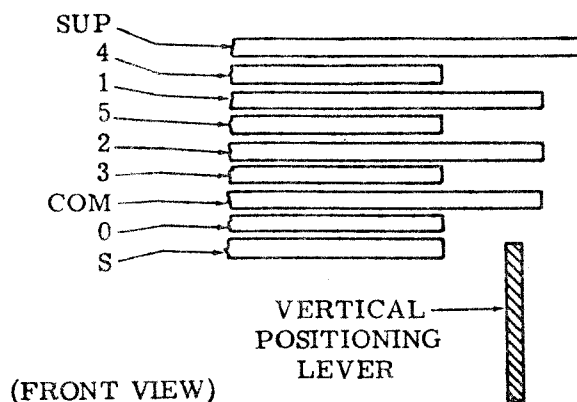

Figure 17 - Vertical Arrangement of Code Bars

CODE BAR OPERATION (Figs. 15, 16 and 17)

7.03 Each selector push lever (6.04) has an associated intermediate arm, transfer lever and code bar shift bar (Fig. 15). In addition, there is a common transfer lever with its code bar shift bar. When a push lever is toward the rear (spacing) its associated intermediate arm and transfer lever are pulled toward each other by a spring. The upper end of the transfer lever is held forward (spacing), holding the code bar shift bar in spacing position. When a push lever is moved forward (marking), it rotates the intermediate arm counterclockwise, positioning the transfer lever to the rear (marking) and holding the code bar shift bar in marking position. The common transfer lever (third from left, operating the common code bar, third from bottom) has an extension which passes behind the number 1 and 2 transfer levers. There is no connection between the common transfer lever and the selecting mechanism, but when either the number 1 or number 2 push bar is selected, the associated transfer levers position the common code bar shift bar to the rear (marking). The right ends of these code bars determine vertical positioning of the type box (Fig. 17).

7.04 As the selector cam clutch completes its revolution, the trip shaft operating lever rides to the peak of the code bar clutch trip cam (Fig. 9). This causes the shaft to turn slightly (counterclockwise, viewed from the right) to move the code bar clutch trip lever away from the clutch stop lug and engage the clutch. Rota-

tion of the clutch operates an eccentric and the shift lever drive shaft, shift lever drive arm and shift lever drive link. The drive link moves two code bar shift levers in a scissors like action, the front lever moving to the left, the rear lever moving to the right. Any code bar shift bar in marking position (left) during the previous operating cycle is moved to spacing position (right) by the forward shift lever, unless the transfer lever is once again holding that bar to the rear (marking). The rear shift bar, as it moves to the left (Fig. 16) carries with it any code bar shift bar held in the marking position, completing the transfer of intelligence from the selecting mechanism to the code bars.

7.05 At the end of one revolution, the code bar clutch trip lever strikes the clutch shoe lever. Inertia of the cam disk assembly causes it to continue to turn to permit the latch lever to drop into the indent in the cam disk, and the clutch is held disengaged. The code bars, code bar shift bars and shift levers are held in the selected position, but the transfer levers and intermediate arms are free to position the shift bars forward or to the rear in response to new input signal intelligence from the selector.

CODE BAR ARRANGEMENT (Fig. 17)

7.06 A total of nine code bars in marking (left) or spacing (right) position convey mechanically translated signal intelligence to the typing and function mechanisms. The code bars are arranged from top to bottom as follows: suppression, number 4, number 1, number 5, number 2, number 3, common, zero (0) and letters-figures shift (S).

8. POSITIONING THE TYPE BOX

GENERAL

8.01 All of the characters (graphics) that may be printed by the typing unit are formed by type pallets which are arranged in a type box. The type box is mounted in a carriage from which it may be removed for cleaning or replacement. In order to print any selected character, the type box carriage is so positioned that the character on the pallet is directly over the desired location on the paper. Since the pallets are arranged in four horizontal rows and sixteen vertical rows, it is necessary to position the type box carriage both horizontally and vertically. See Fig. 18 for arrangement of graphics which are represented on the type box pallets. See Fig. 6 for input signal code permutations equivalent to each graphic representation.

8.02 The type box carriage rides on rollers over a track which is moved vertically for positioning in that particular plane. The carriage is positioned horizontally on its track by the oscillating rail slide and type box carriage link. The slide rides the oscillating rail and is clamped to the rear section of the upper draw wire rope. The link provides a flexible connection to permit the type box carriage to follow both the vertical movement of the type box carriage track and the horizontal movement of the oscillating rail slide.

8.03 The lower right rear end of the upper draw wire rope is fastened to the spacing drum. From this point, it passes part way around the spacing drum, upward and around

		LETTERS				FIGURES			
		LEFT		RIGHT		LEFT		RIGHT	
		4 8 5 MARKING	4 5 MARKING	4 5 MARKING	4 8 5 MARKING	4 8 5 MARKING	4 5 MARKING	4 8 5 MARKING	4 8 5 MARKING
TOP ROW		M	N	H	SPACE	BLANK	T	G. R.	O
		-- 3 4 5	-- 3 4	-- 3 5	-- 3 --	---	---	---	4 5
2ND ROW		X	F	Y	S	E	Z	D	B
		1- 3 4 5	1- 3 4	1- 3 5	1- 3 --	1- ---	1- ---	1- ---	1- 4 5
3RD ROW		V	C	P	I	L F	L	R	G
		- 2 3 4 5	- 2 3 4	- 2 3 5	- 2 3 --	- 2 ---	- 2 ---	- 2 ---	- 2 4 5
BOTTOM ROW		LETTERS	K	Q	U	A	W	J	FIGURES
		1 2 3 4 5	1 2 3 4	1 2 3 5	1 2 3 --	1 2 ---	1 2 ---	1 2 4	1 2 4 5
		3 MARKING				3 SPACING			
		4TH ROW	3RD ROW	2ND ROW	1ST ROW	1ST ROW	2ND ROW	3RD ROW	4TH ROW

Figure 18 - Typical Type Box Pallet Arrangement

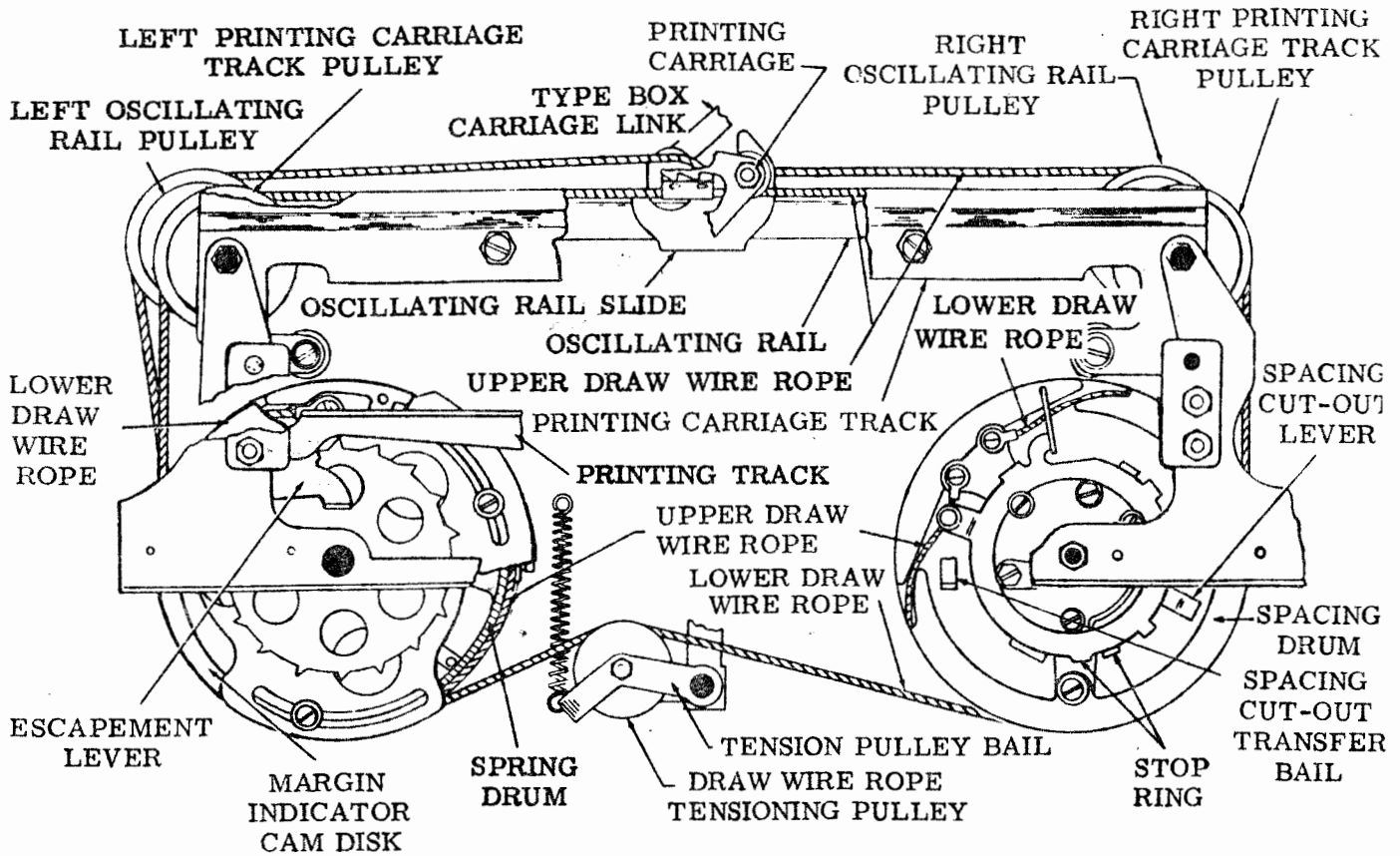

Figure 19 - Draw Wire Rope and Drums (Front View)

the right rail pulley and downward to the spring drum. After passing part way around the spring drum, the upper draw wire rope is doubled backward around it and passes upward to the left printing carriage rail pulley over to the right printing carriage rail pulley, and downward to the spacing drum to which it is again fastened. The lower draw wire rope is fastened at its left end to the spring drum and, at its right end, to the spacing drum. It acts in opposition to the upper draw wire rope and holds the two drums in phase (Fig. 19). A tensioning pulley rides the under side of the lower draw wire rope, to take up any slack which may occur due to stretching of the upper and lower draw wire ropes.

8.04 The oscillating rail is supported by pivoted arms at each end. These arms which extend downward are pivoted on the typing unit frame at their lower ends. Thus, the oscillating rail and draw wire rope that it carries with it may be shifted to the left or right with no change in position relative to each other. The oscillating rail shift slide and two oscillating rail shift

links are used to accomplish the horizontal positioning of the oscillating rail and also connect it with the oscillating rail shift slide. The links are pivoted and are such a length that only one at a time may be fully extended.

LETTERS-FIGURES SHIFT (Fig. 20)

8.05 Mechanical limitations restrict the selection from the type box pallets to four horizontal rows and eight vertical rows. With a total of sixteen vertical rows in the type box, it is necessary to determine which of two fields, letters (left half of type box) or figures (right half of type box) will be presented for printing. To accomplish this, a special non-printing signal combination is used for each shift operation. Upon receipt of the letters or figures shift signal, mechanisms provided in the stunt box initiate the shifting operation. This, as are other non-printing operations, is described under Functions. The operation of the mechanisms that perform the actual shifting of the type box, however, are described below.

8.06 The lower most code bar, designated S, contains a pin near its right end that projects upward to permit engagement with the stunt box. The code bar is positioned to the left (the figures position) or to the right (the letters position). A slotted extension of the S code bar engage a tongue from the right end of the letters-figures shift slide and causes it to follow the S code bar movements. Pins at the end of the shift slide serve as lower guides for the right and left shift link breaker slides. Pins which project from the front plate serve as upper guides and pivot points. The main bail has left and right breaker slide bails mounted on its ends.

8.07 Upon receipt of the signal code for the letters shift operation, the shift slide is

moved to the right (Fig. 20). This positions the left shift link vertically with its lower end over the left breaker slide bail. The right breaker slide is positioned such that its lower end is to the right of the right breaker slide bail. As the main bail moves upward, the right breaker slide bail clears the right breaker slide, but the left breaker slide bail engages the left breaker slide and moves it upward. As a result of this action, the left oscillating rail shift links open and the oscillating rail is permitted to be moved to the right. This action presents the letters field in line for printing. In a similar manner, when the signal code for the figures shift is received, the right oscillating rail shift links are opened, the oscillating rail shifts to left, and the figures field of the type box is in line for printing.

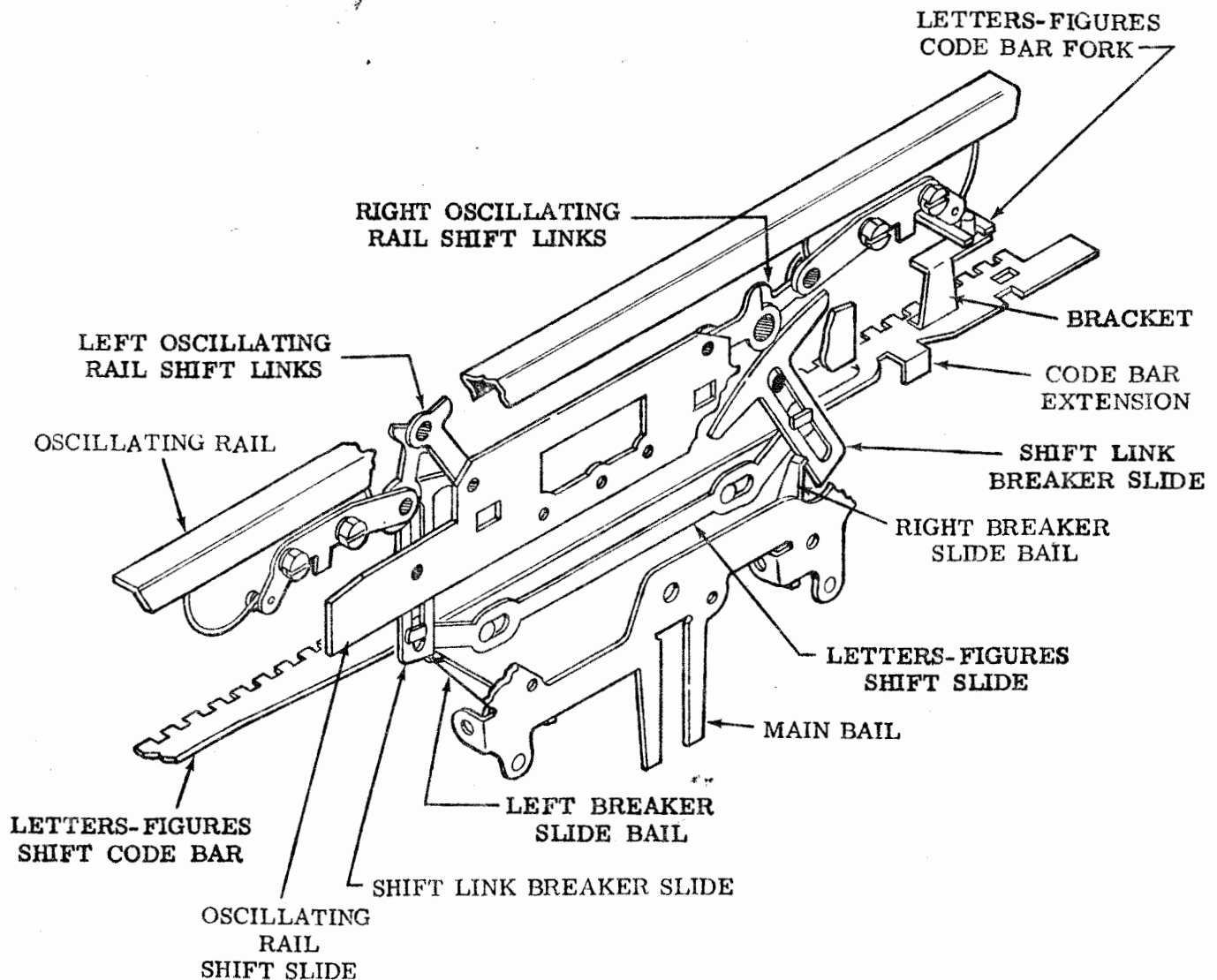

Figure 20 - Letters-Figures Shift Mechanism (Left Front View)

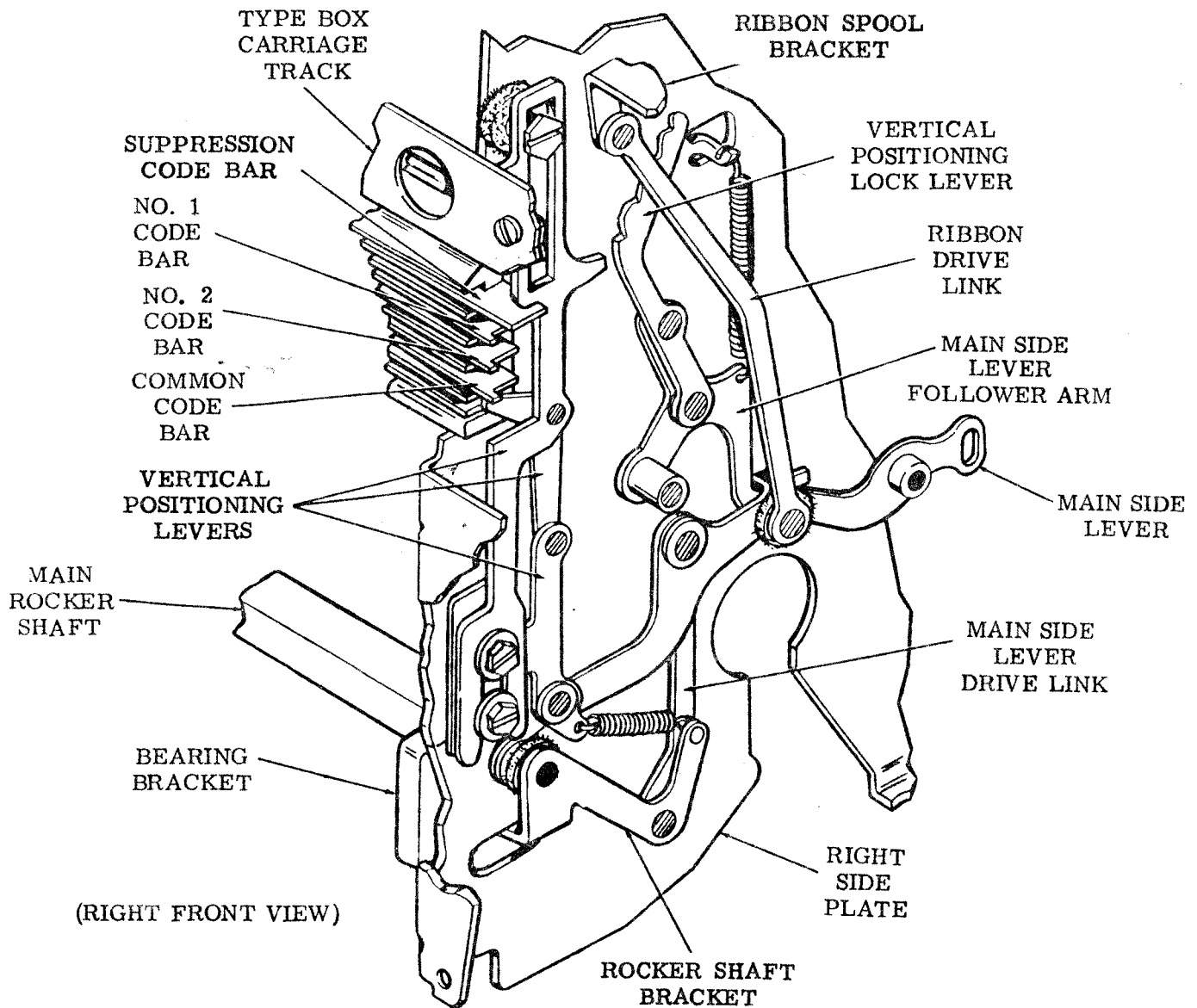

Figure 21 - Vertical Positioning Mechanisms

VERTICAL POSITIONING (Fig. 21)

8.08 The selection of the various characters from the four horizontal rows and eight vertical rows in either field (figures or letters) and the printing of those characters take place as follows:

8.09 The number 1 and number 2 code bars determine the selection of the horizontal row. The number 3 code bar determines whether the selection is to be made from the left four vertical rows or the right four vertical rows (in

either the figures or the letters field). The number 4 and number 5 code bars determine the selection of one row from the four vertical rows predetermined by the number 3 code bar.

8.10 Four code bars (longer than the others) extend through the right code bar bracket and serve as stops for the right vertical positioning levers (Fig. 21). They are (from top to bottom) the suppression, number 1, number 2 and common code bars. Notches are arranged in the left ends of these code bars so that the left side vertical positioning levers are stopped,

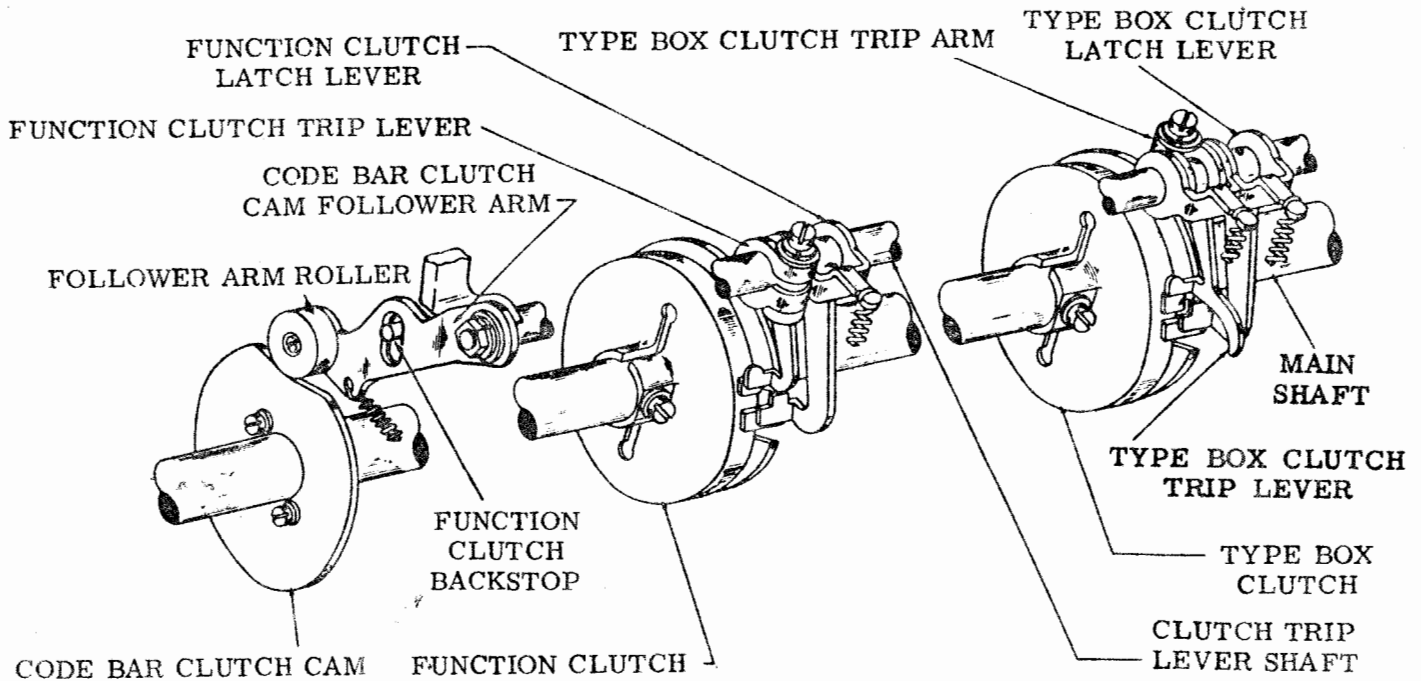

Figure 22 - Clutch Trip Mechanism (Right Rear View)

in each case, by the same bar that blocks the right side levers. After all code bars have been positioned by the code bar positioning mechanism, the code bar clutch cam follower arm and its roller, in traversing the sloping indent on the code bar clutch cam, rotates the clutch trip lever shaft. As the shaft turns, it first causes the function clutch lever to release the function clutch (Fig. 22) and then causes the type box clutch trip arm to engage its trip lever and release the type box clutch. When the type box clutch completes its revolution, it is disengaged by its trip lever and latch lever in the same manner as was the code bar clutch (7.05). During its rotation, the type box clutch operates a drive link and a bracket to cause the main rocker shaft to oscillate. This, in turn, through its left and right brackets and the main side drive links, extends the motion to the vertical positioning levers (Fig. 21). These levers are driven upward until they strike a projecting code bar, which causes them to buckle. The type box carriage track is mounted between the vertical positioning levers, and its vertical motion is controlled by them.

8.11 When the number 1 and number 2 code bars are toward the right (spacing), the common code bar is also toward the right, where it blocks the vertical positioning levers.

The top row of pallets in the type box are then in line for printing. When the number 1 code bar is toward the left (marking), the common code bar is toward the left. If the number 2 code bar is toward the right (spacing), it blocks the vertical positioning levers, and the second row of pallets (from the top) are then in line for printing. When the number 1 code bar is toward the right (spacing), and the number 2 code bar is toward the left (marking), the common code bar is toward the left. The number 1 code bar blocks the vertical positioning levers and the third row of pallets is in line for printing. When both the number 1 and number 2 code bars are to the left (marking), the common code bar is also to the left. The suppression code bar blocks the vertical positioning levers, and the fourth (bottom) row of pallets in the type box are then in line for printing. At each of the four levels at which the vertical positioning levers may be stopped, they are locked momentarily by lock levers controlled by the main side lever follower arms.

HORIZONTAL POSITIONING (Figs. 23 and 24)

8.12 A bracket attached to the main rocker shaft applies vertical motion to the main bail by means of two main bail links (Fig. 23). Attached to each end of the oscillating rail shift

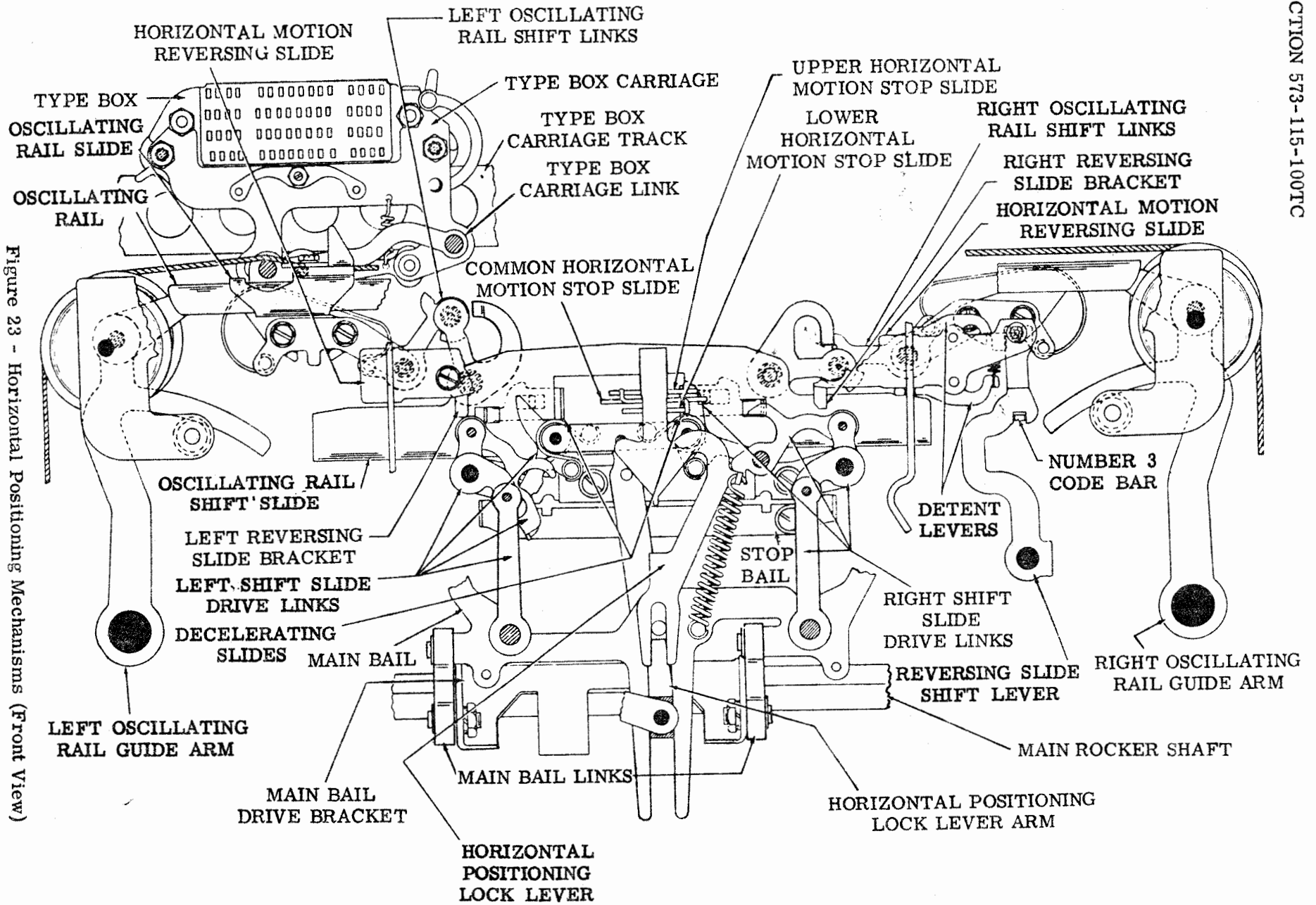

Figure 23 - Horizontal Positioning Mechanisms (Front View)

slide are pivoted, buckling-type drive links which extend downward to each end of the main bail. As the main bail moves downward under impetus of the type box clutch, the left shift slide links, if not buckled, will try to shift the oscillating rail slide drive links toward the right, while the right slide drive links, if not buckled, will try to shift the oscillating rail shift slide links to the left. When the number 3 code bar is shifted toward the left (marking), the horizontal motion reversing slide is shifted toward the left by the reversing slide shift lever, and is held there by detent levers. A bracket near the right end of the reversing slide will then make contact with the right shift slide drive links and cause them to buckle. As the main bail is driven downward, the unbuckled left shift slide drive links will start to shift the oscillating rail shift slide toward the right. This positions the type box so that the characters to be printed

will be located in the left half of the figures or the letters field. In a similar manner, when the number 3 code bar is shifted toward the right (spacing), the horizontal motion reversing slide is also shifted toward the right by the shift lever and is held there by the detent levers. A bracket near the left end of the horizontal motion reversing slide then makes contact with the left shift slide drive links and causes them to buckle. As the main bail is driven downward, the unbuckled right shift slide drive links will start to shift the oscillating rail shift slide toward the left. This positions the type box so that the characters to be printed will be located in the right half of the figures or the letters field.

8.13 After determination of the field (figures or letters) and the group of vertical rows in which the character to be printed is located, the number 4 and number 5 code bars operate

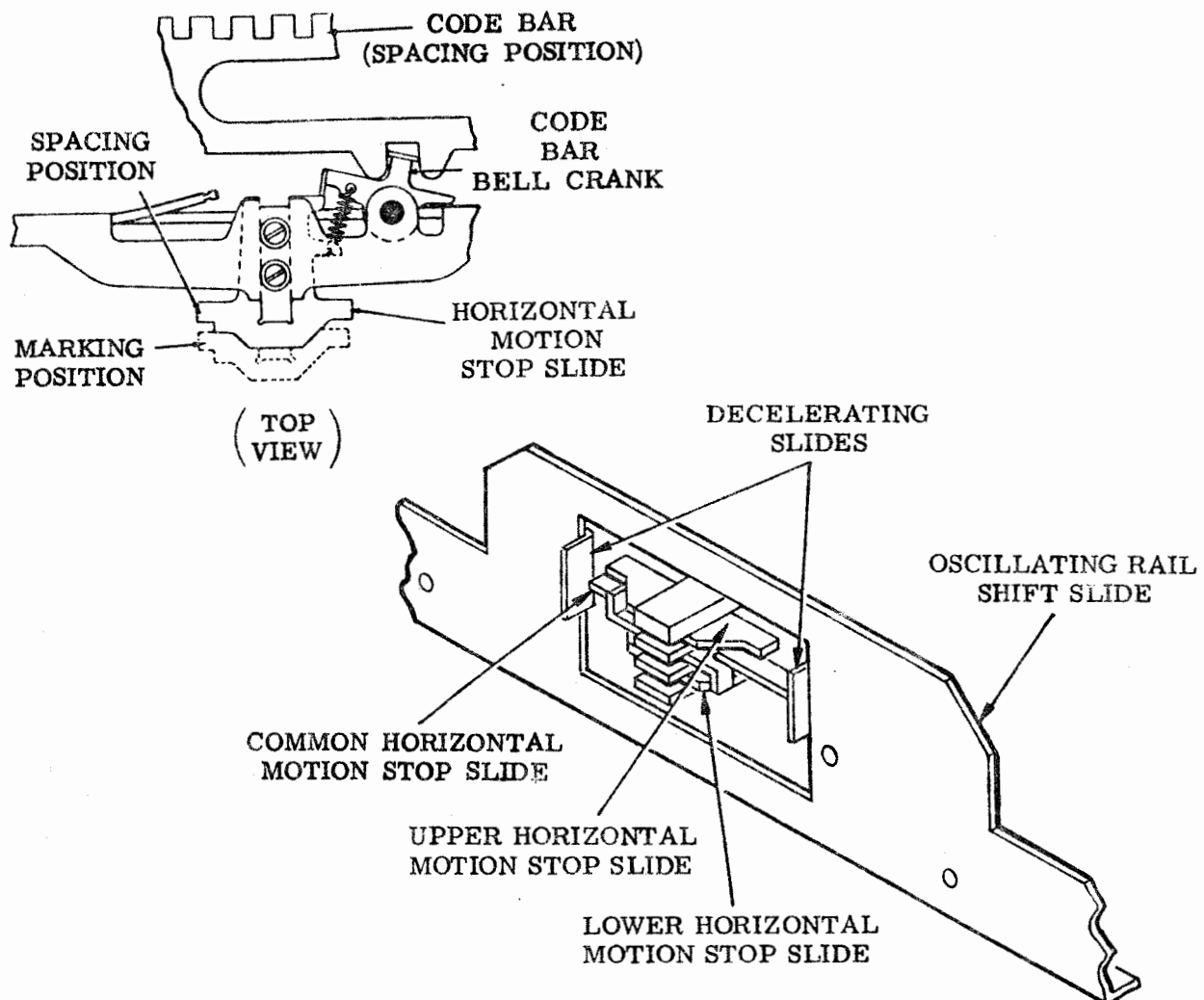

Figure 24 - Horizontal Motion Stop Slides (Right Front View)

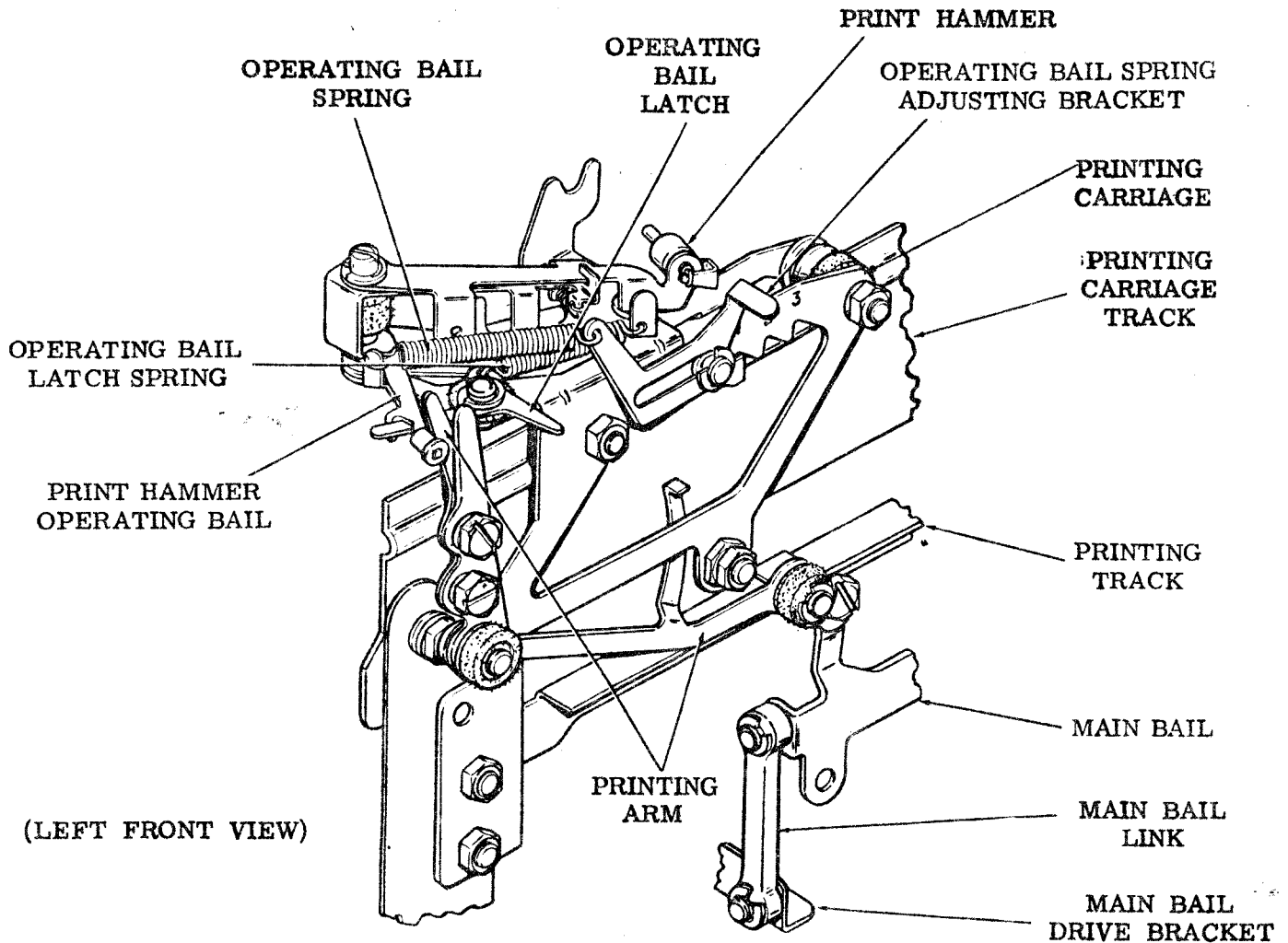

Figure 25 - Print Hammer and Carriage

three horizontal motion stop slides to determine the row in that group in which the character is to be found (Fig. 24). A wedge shaped horizontal positioning lock lever which is pulled downward by the main bail through a yield spring bears against the horizontal positioning lock lever arm. This arm drives the oscillating rail shift slide in the direction in which it was started (by the number 3 code bar selection) until one of two decelerating slides which are mounted on the oscillating rail shift slide strikes an unselected horizontal motion stop slide. A camming surface on the unbuckled shift slide drives the decelerating slide and causes the drive links to buckle. The oscillating rail shift slide finally comes to rest when it strikes the blocked decelerating slide. This, in turn, ends the downward excursion of the lock lever, and the yield spring

extends until the main bail reaches the lowest point of its oscillation. As the main bail returns upward, it centers the oscillating rail shift slide. It is during this time that the horizontal motion stop slides are positioned for the selection of the next character. The number 4 and number 5 code bars each operate a code bar bail bell crank. Each, in turn, moves a horizontal motion stop slide toward the front (marking) or toward the rear (spacing) (Fig. 24). A third (common) stop slide (spring tensioned toward the rear) is located between the upper and lower stop slides and has projections which pass across the front edges of these slides (Fig. 23). Each stop slide is of a different length. The common stop slide, which is the longest stop, has an additional stop on its shank, so that it serves as the shortest stop when all the slides are moved forward.

The upper slide (operated from the number 4 code bar) is the second longest stop, and the lower slide (operated from the number 5 code bar) is the third longest stop.

8.14 When both the number 4 and number 5 code bars are moved toward the right (spacing), their respective horizontal motion stop slides are toward the rear. The oscillating rail shift slide is moved to the right or left of its central position (determined by the number 3 code bar) until it is stopped by one end of the common horizontal motion stop slide. This positions the first vertical row (right or left of the center of the figures field or the letters field) in line for printing. When the number 4 code bar is toward the right (spacing), and the number 5 code bar is toward the left (marking), the lower and the common stop slides are toward the front, and the upper stop slide is toward the rear. The oscillating rail shift slide is moved to the right or left of its central position until it is stopped by one end of the upper stop slide. This positions the second vertical row (right or left of the center of the figures field or the letters field) in line for printing. When the number 4 code bar is toward the left (marking) and the number 5 code bar is toward the right (spacing), the upper and the common stop slides are toward the front and the lower stop slide is toward the rear. The oscillating rail shift slide is moved toward the right or left of its central position until it is stopped by one end of the lower stop slide. This positions the third vertical row (right or left of the center of the figures field or the letters field) in line for printing.

8.15 When both the number 4 and the number 5 code bars are toward the left (marking), their respective horizontal motion stop slides and the common stop slide are toward the front. The oscillating rail shift slide is moved toward the right or left of its central position until it is stopped by one side of the shank of the common stop slide. This positions the fourth vertical row (right or left of the center of the figures field or the letters field) in line for printing.

9. PRINTING

9.01 After the type box has been moved so that the selected type pallet is in its proper position, it must be struck by a print hammer in order to print. This is accomplished by the action of the printing carriage located on the printing carriage track at the top of the front plate mechanism.

POSITIONING (Figs. 23 and 25)

9.02 The printing carriage rides on rollers on the printing carriage track, which is rigidly attached to the typing unit front plate. The carriage is clamped to the forward section of the upper draw wire rope. This moves the carriage along its track in such a manner that the hammer advances to the next printing position after each character (graphic) is imprinted.

OPERATION

9.03 The printing track which is located on the front of the typing unit (Fig. 25) is fastened to an extension at each end of the main bail. As the main bail reciprocates vertically, it extends the motion through the printing track, which travels in guides located at each end of the track. The printing arm, which extends downward from the printing carriage, rides the printing track. As the arm follows the reciprocating motion of the track, its upper end moves first toward the left and then toward the right. When the upper end of the arm moves toward the left, it rotates the print hammer operating bail clockwise against its spring tension until it becomes latched by the operating bail latch.

9.04 The print hammer operating bail draws the print hammer away from the type box by means of the print hammer bail spring. When the upper end of the printing arm moves to its extreme right position, it makes contact with the latch and causes it to release the print hammer operating bail. The operating bail is swung in a counterclockwise direction by the operating bail spring until it strikes its stop. The print hammer bail, in being driven by the operating bail, is swung toward the type box. When the operating bail is stopped, momentum causes the print hammer bail to continue its travel against the tension of the print hammer bail spring until the printing hammer strikes the selected type pallet. The force with which the hammer strikes is adjustable to three positions marked on the carriage.

10. SPACING

GENERAL (Figs. 25 and 26)

10.01 To space the printed character properly, the type box and printing carriages must be advanced with each character printed. The spacing must also be accomplished when the input signal code combination represents a letter space. As was shown in 8.02 and Fig. 19, the carriages are connected to a draw wire rope

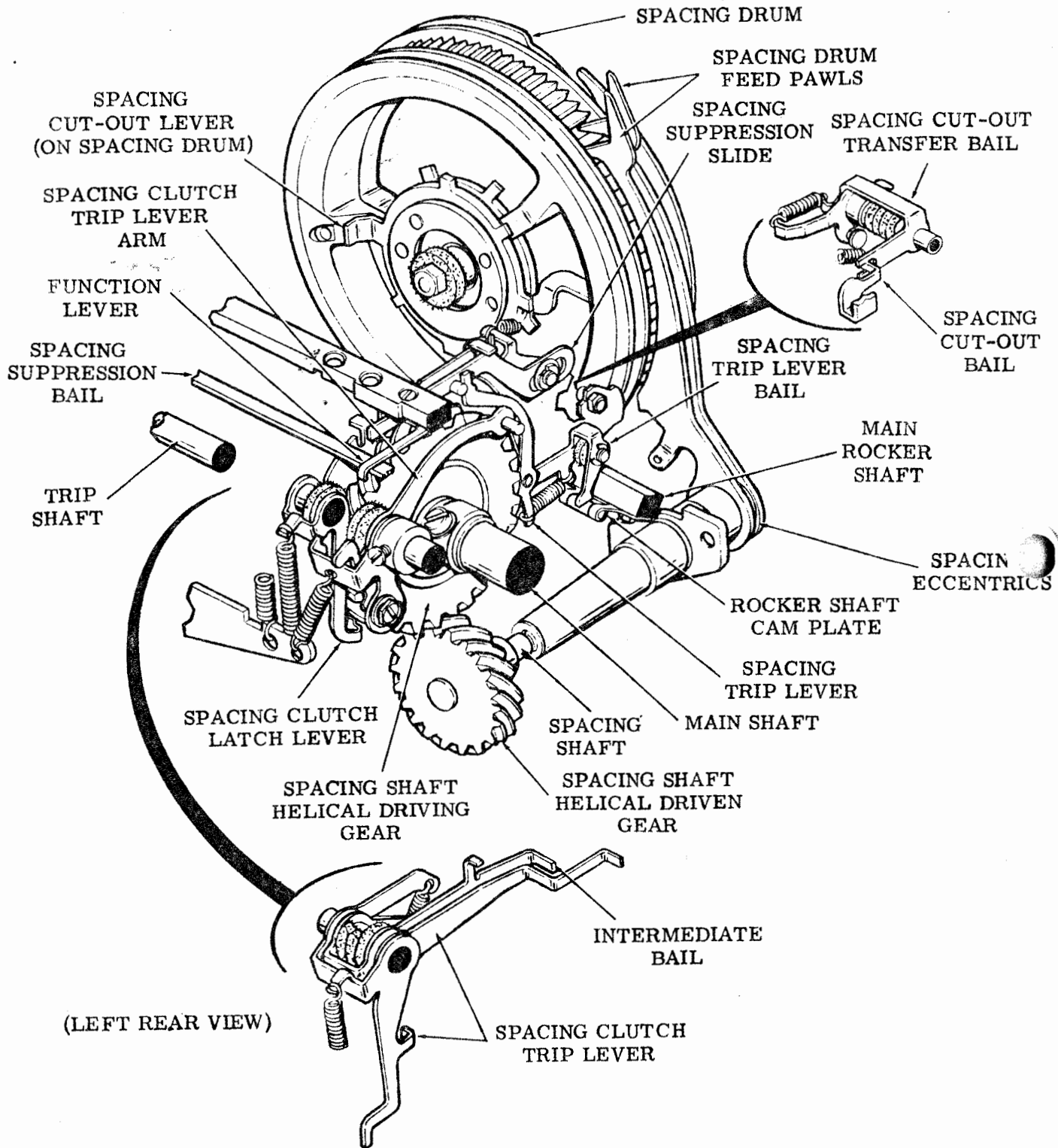

Figure 26 - Spacing Mechanism

which, in turn, is fastened to the spring drum and the spacing drum. The purpose of the spring drum, which contains a torsion spring, is to tension the draw wire rope and pull the carriages to the left. The spacing drum has ratchet teeth about its perimeter which are engaged by the eccentric driven spacing drum feed pawls (Fig. 26). The spacing shaft which mounts the spacing eccentrics is driven through its helical gear attached to the three stop spacing clutch on the main shaft. The gear ratio of 1-1/2 to 1 causes the spacing shaft to turn one-half a revolution each time the spacing clutch is tripped. This allows the feed pawls to advance the spacing drum by one ratchet tooth.

10.02 The same trip shaft which, through a cam on the code bar clutch (4.05) trips the function clutch, also rotates the type box clutch tripl lever counterclockwise (viewed from the left). Unless movement of this lever is blocked by the print suppression mechanism, the type box clutch is engaged, oscillating the main rocker shaft, which drives the printing mechanism (8.10). A cam plate (Fig. 26) fastened to the bottom of the rocker shaft is moved upward by the shaft as it begins its movement. The cam plate operates the spacing trip lever bail. As this bail is rotated, it raises the spacing trip lever until it latches onto the spacing clutch trip lever arm. As the rocker shaft reverses its direction of rotation, the spacing trip lever bail and the trip lever move downward under spring tension, causing the latched up spacing clutch trip lever arm to operate the spacing clutch trip lever and engage the spacing clutch.

10.03 Before the spacing clutch completes one-third of a revolution, its restoring cam moves the spacing tripl lever about its pivot point until it releases the spacing clutch trip lever, which returns to its normal position in time to stop the spacing clutch after one-third of a revolution. The spacing clutch three-stop cam disk upon which the latch lever rides has an indent at each stop position. When one of the three lugs on the clutch shoe lever disk strikes the spacing clutch trip lever, the inertia of the cam disk assembly causes it to turn until its lugs make contact with the lugs on the clutch shoe lever disk. The latch lever drops into an indent in the cam disk, and the clutch is held disengaged until the trip lever is again operated.

SPACE FUNCTION

10.04 The non-typing function by which spacing between words or any spacing other than that which accompanies printing is accomplished

is initiated when the code bars are set in a combination equivalent to the spacing code combination (all spacing except third pulse marking). The function is executed through the code bar clutch, tripping the printing clutch, and the spacing clutch as described in 10.01-10.03. For this function, the type box is positioned so that a vacant pallet (top horizontal row, first right row in the figures field) is presented beneath the type hammer. No printing occurs when the type hammer is tripped in its normal fashion. The stunt box is not involved in the execution of this function.

SPACE SUPPRESSION (Fig. 26)

10.05 When certain non-typing functions are selected or when the carriages reach their extreme right position, it is necessary to suppress spacing to avoid interference with the page printed message or damage to the equipment. This is accomplished by moving the spacing suppression slide forward to a point at which it will hold the upper end of the spacing trip lever forward and prevent it from engaging the spacing clutch trip lever.

10.06 In the case of spacing suppression on selection of a function code combination, the spacing suppression slide is shifted forward by the spacing suppression bail, mounted beneath the function box. When space suppressing function levers are selected, they engage the bail and, when the function mechanism is operated, move the bail forward. Moved forward with the bail, the suppression slide prevents engagement of the spacing clutch.

10.07 When the carriages are near their extreme right position, a cut-out ring on the spacing drum engages the spacing cut-out transfer bail (Fig. 26), which in turn operates the spacing cut-out bail. The ring and the end of the spacing cut-out transfer bail are shown in Fig. 19. The spacing cut-out bail shifts the spacing suppression slide forward and prevents engagement of the spacing clutch until the carriages are returned. The maximum number of characters which the typing unit may print is eighty-five, including spacing function spaces. In order to prevent spacing beyond this point, and subsequent damage to the equipment, several teeth are omitted from the spacing drum ratchet wheel.

MARGIN INDICATOR (Fig. 19)

10.08 When used in conjunction with a keyboard base, the typing unit actuates a margin indicator switch (base mounted). Before the type

box carriage reaches the end of its travel, an actuator mounted on the face of the spring drum operates the switch contact. The angular position of the cam disk with respect to the spring drum may be altered to change the point at which the indicator contact will be closed.

11. RIBBON FEEDING

DESCRIPTION (Fig. 27)

11.01 The left and right ribbon feed mechanisms oscillate in a vertical plane with

each revolution of the type box clutch. They are driven by ribbon drive links attached to the main side levers (Fig. 21). At their uppermost positions, the ribbon mechanisms position the ribbon relative to the horizontal type box row being printed. After each character is printed, the ribbon mechanisms are dropped downward together with and behind the type box, to permit viewing of the last printed character. The ribbon is held in place at the point of printing by a ribbon guide fastened to the rear of the type box carriage.

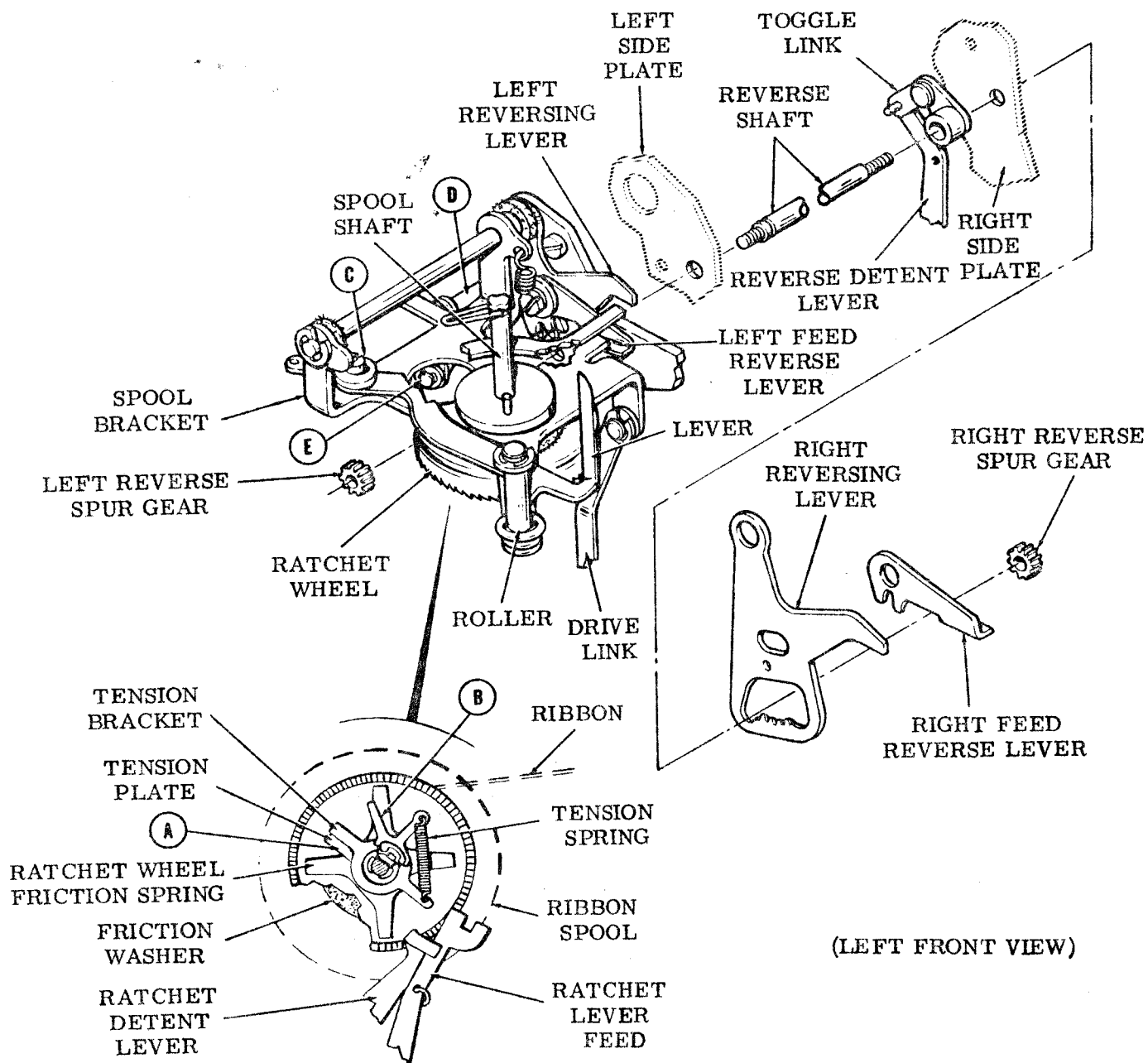

Figure 27 - Ribbon Feeding Mechanism

11.02 Each of the ribbon mechanisms consist of a bracket which is hinged at its rear end, and upon which is mounted a ribbon spool shaft (Fig. 27). A ribbon tension bracket is keyed to the lower end of the ribbon spool shaft. A ribbon ratchet wheel is mounted freely on the ribbon spool shaft just below the ribbon spool bracket, from which it is separated by a friction washer. This applies a constant drag to the ratchet wheel.

OPERATION

11.03 A ribbon tension plate which is keyed to the hub of the ribbon ratchet wheel has two projecting lugs (A and B, Fig. 27) that straddle the lug on the ribbon tension bracket. A ribbon tension spring tends to maintain the ribbon tension bracket against lug A of the ribbon tension plate. In operation, the ribbon spool bracket, driven by the ribbon drive link, pivots about point C. The ratchet feed and ratchet detent levers pivot about points D and E respectively and are held against the teeth on the ribbon ratchet wheel by their springs. As the ribbon spool bracket is moved upward, the ratchet wheel feed lever skips over one tooth, while the ratchet detent lever holds the ribbon ratchet wheel from turning backward. When the ribbon spool bracket is moved downward, the ratchet feed lever engages a ratchet tooth and pushes the ratchet wheel. A tooth on the ribbon ratchet wheel then skips over the ratchet detent lever. The teeth on the left and right ribbon ratchet wheels face in opposite directions so that when their feed levers are engaged, the left ribbon ratchet wheel turns counterclockwise (viewed from the top).

11.04 In order for the ribbon to be pulled from one ribbon spool to the other, only one of the ribbon mechanism can have its ratchet feed and ratchet detent levers engaged with its ribbon ratchet wheel at a time. As the ribbon ratchet wheel turns, the ribbon tension plate also turns, and extends the ribbon tension spring. When the lug B of the ribbon tension plate makes contact with the ribbon tension bracket, the ribbon spool shaft is made to turn, and the ribbon is wound on the ribbon spool.

RIBBON REVERSING

11.05 When the ribbon has been completely unwound from one spool, it is necessary to reverse its direction so it can rewind. This is accomplished automatically by disengaging one set of ratchet feed and ratchet detent levers and engaging the other set. While the ribbon is pass-

ing from the left spool to the right spool, the right set of levers is engaged. The left set is held disengaged against the tension of the springs by the left ribbon feed reverse lever, which is in its downward position (Fig. 27). The lever is held in this position by means of the ribbon reverse detent lever through the intervening ribbon reverse detent cam, ribbon reverse shaft and ribbon reverse spur gear. As the ribbon unwinds from the ribbon spool, it passes around the ribbon roller and through the slot in the end of the ribbon lever. When the ribbon nears its end of the ribbon spool, an eyelet which is fastened to the ribbon catches in the ribbon lever slot and pulls the lever toward the right.

11.06 The next time the ribbon mechanism is moved upward, the displaced ribbon lever engages the end of the left ribbon reversing lever and causes it to move to the position shown in phantom in Fig. 27. As the lever moves, its teeth rotate the left spur gear which, through the ribbon reverse shaft, turns the detent cam and the right spur gear. As the right spur gear moves the right ribbon reversing lever downward, a pin on the lever drives the right ribbon feed lever downward to disengage the ratchet feed and wheel. At the same time a pin on the left ribbon reversing lever moves the left ribbon feed reversing lever upward to permit the left ratchet feed and detent levers to engage the left ribbon ratchet wheel. Thus, the ribbon mechanisms are positioned to rewind the ribbon on the left ribbon spool. When it nears its end on the right ribbon spool, the ribbon is again reversed in a manner similar to that just described. During the reversing cycle, the ribbon is maintained taut by the previously extended ribbon tension spring.

12. PAPER FEEDING (FRICTION FEED)

12.01 Paper for the page printed message is stored on a roll 8-1/2 inches wide, mounted on a paper spindle suspended between the two side plates at the rear of the typing unit. From the roll, the paper passes over a paper straightener shaft, downward behind the platen (Fig. 28) and between the platen and three pressure rollers. A paper pressure bail at the front of the platen equalizes pressure brought to bear on the paper by the pressure rollers. The pressure bail can be released by rotating the paper release lever at the top of the right side plate to the rear (clockwise, viewed from the right) when it is necessary to straighten the paper or to remove paper from the platen. Two paper fingers operated on a spring tensioned shaft

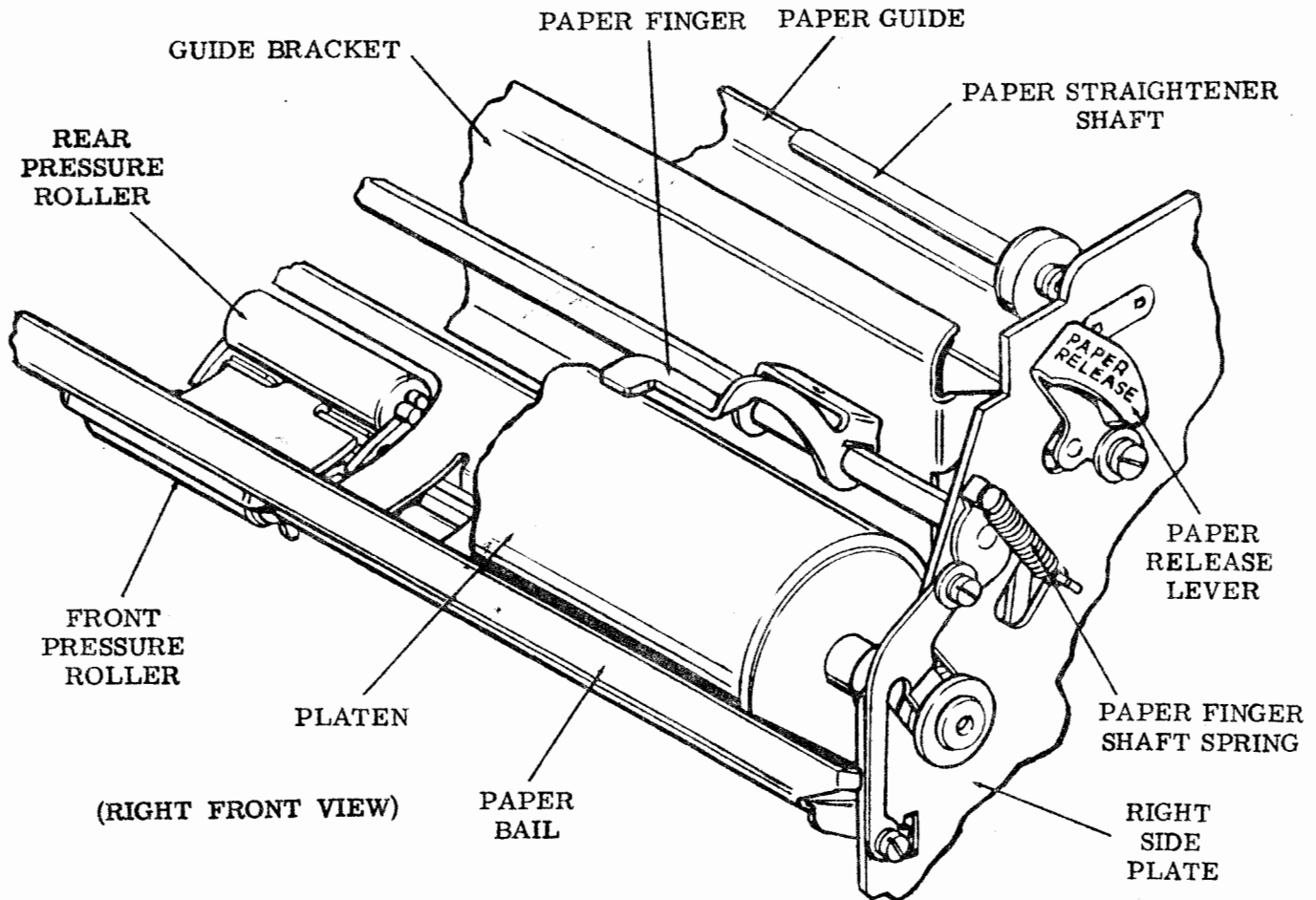

Figure 28 - Friction Feed Platen Mechanism

across the front of the platen hold copy paper firmly against the plate, in position for printing.

13. STUNT BOX OPERATION

FUNCTIONS (Fig. 29)

13.01 There are two types of operation which can be performed by the typing unit. The first embodies those mechanical actions which are directly necessary to the actual printing of a character (or space function). The second embodies mechanical action which alters the positions of the various mechanisms or activates external devices or circuits through switching contacts. The latter are known as functions.

Note: Spacing may technically be considered a function, but it is mechanically associated with the printing operation, except when suppressed by function mechanisms.

13.02 As in printing, the reception of function codes results in the positioning of the code bars (7.01). The back edges of the code bars are notched (Fig. 30). Positioned directly behind the code bars is a stunt box, which contains the function bars for the various functions (Figs. 29 and 30). Each function bar has a series of tines on its end, offset to one side or the other to correspond with the marking and spacing elements of the particular input signal code combination to which it is to respond. Tines positioned to the right are spacing; those to the left are marking.

13.03 When the function clutch is engaged (Fig. 22), it rotates and extends motion to the function bar reset bail (through the intervening cam and follower arm and function rocker shaft) to cause the function bar reset bail with its attached reset bail blade to release the function bars momentarily (Fig. 31). As the spring tensioned function bars are released, they move forward to bear against the code bars. If

SLOT
NUMBER

MANDATORY
POSITION
FOR

SHIFT FORK POSITIONS
WITH ASSOCIATED CODE
BAR INDICATED

- 1 UNSHIFT-ON-SPACE
- 2 FIGURES SHIFT
- 3 LETTERS SHIFT
- 4 AUTOMATIC CR
- 5 CR
- 9 ON-LINE BACKSPACE
- 17 HORIZONTAL TAB

LETTERS-FIGURES
SHIFT CODE BAR

SUPPRESSOR
CODE BAR

SUPPRESSOR
CODE BAR

ZERO CODE BAR

SUPPRESSOR
CODE BAR

SUPPRESSOR
CODE BAR

SUPPRESSOR
CODE BAR

SUPPRESSOR
CODE BAR

SUPPRESSOR
CODE BAR

SUPPRESSOR
CODE BAR

SUPPRESSOR
CODE BAR

FUNCTIONS NOT ASSIGNED TO SPECIFIC SLOTS
SPACE SUPPRESSION FOR SINGLE LF
SIGNAL BELL CONTACT
BUSY LIGHT CONTACT
MOTOR STOP CONTACT

- 35 KEYBOARD LOCK
- 36 KEYBOARD LOCK
- 39 AUTOMATIC LF
OR
ON-LINE REVERSE LF
- 40 LF
- 41 ON-LINE REVERSE LF
- 42 FORM FEED OUT

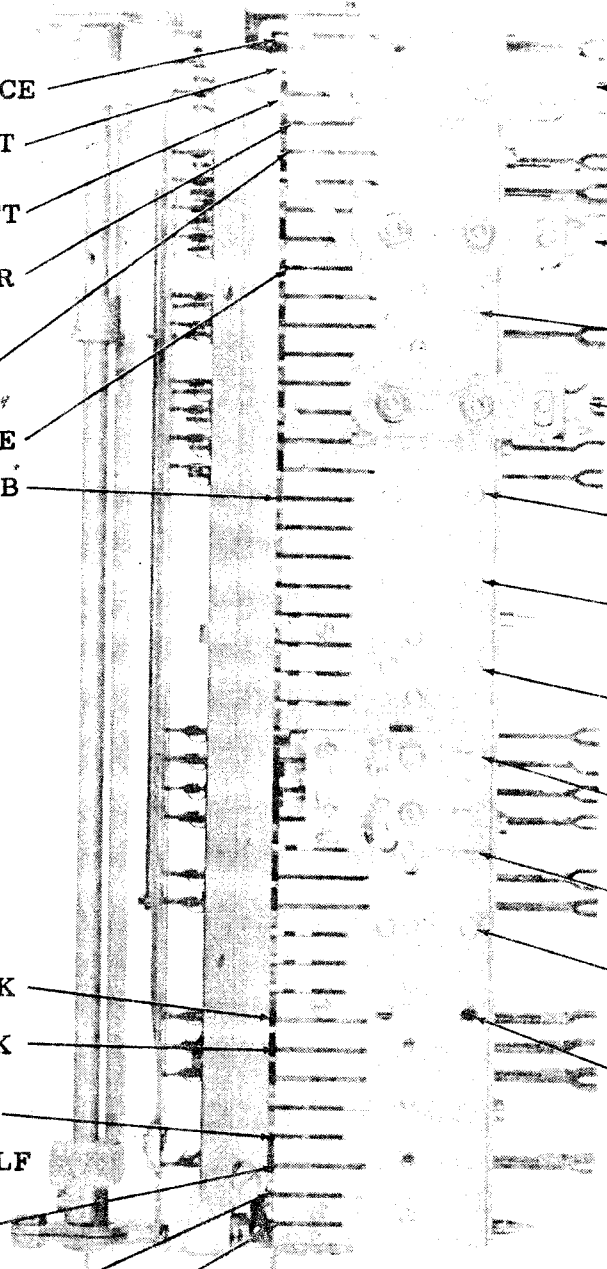

Figure 29 - Stunt Box (Top View)

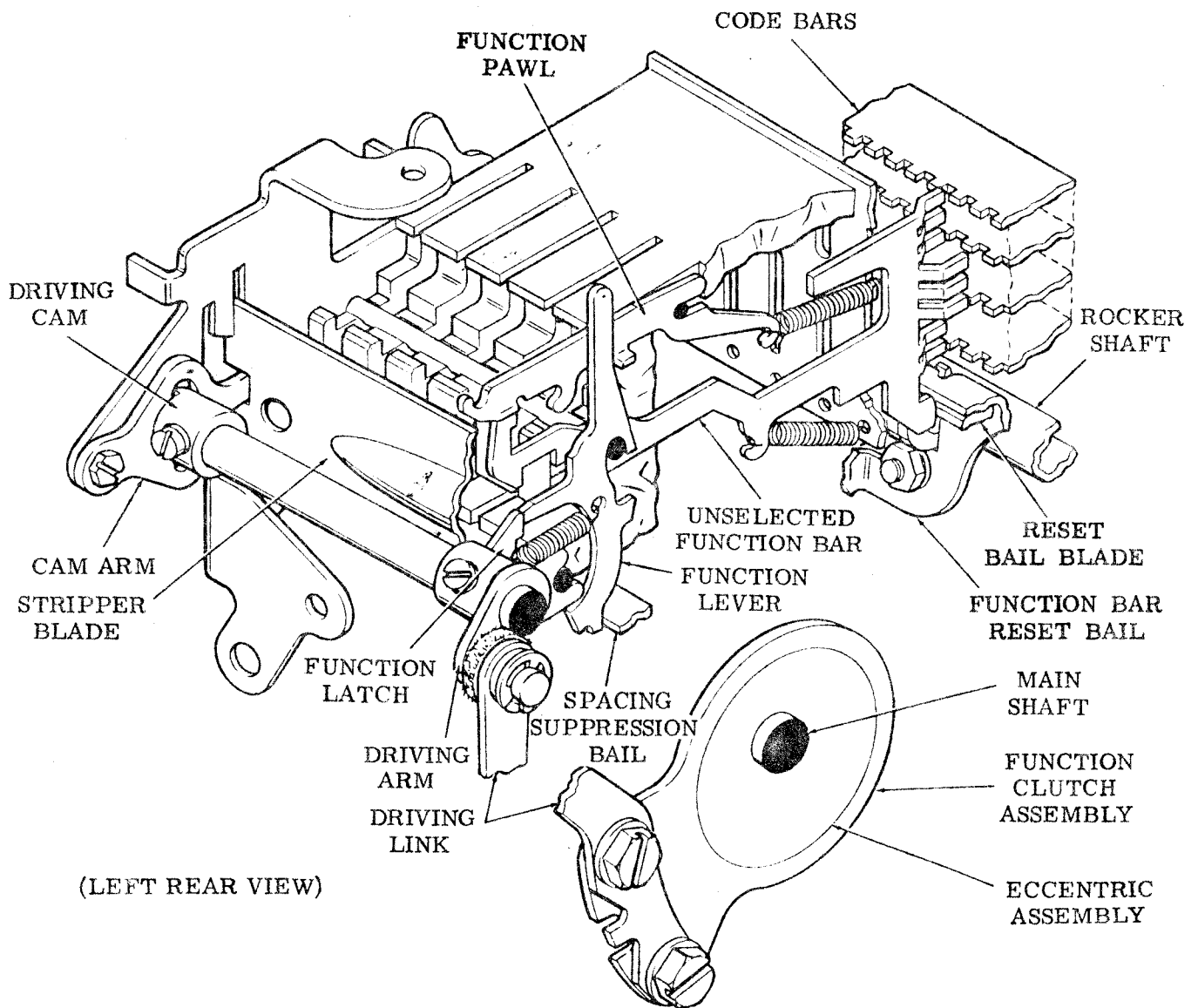

Figure 30 - Stunt Box (Function Linkage Unselected)

the code bars are positioned for a function, each tine on the function bar for that function will be opposite a notch in the code bar. This will permit the selected function bar to continue to move forward into the code bars, while the other function bars are blocked by one or more code bars (Fig. 32).

13.04 Associated with each function bar in the stunt box is a function pawl and a function lever. In the unselected position, the function bar is not latched with its function pawl (Fig. 33). When the function bar reset bail

blade releases the function bars, any selected bar will move sufficiently forward (to the left, in Fig. 33) to permit it to engage its function pawl. Then, as the reset bail blade returns the function bar to its initial position, the function bar carries the function pawl to the rear (to the right, Fig. 34). The function pawl, in turn, moves the function lever clockwise about its pivot point. A projection at the lower end of most function levers operates the spacing suppression bail (10.06), and the selected levers move the bail forward. Either the upper or the lower end operates the indicated function.

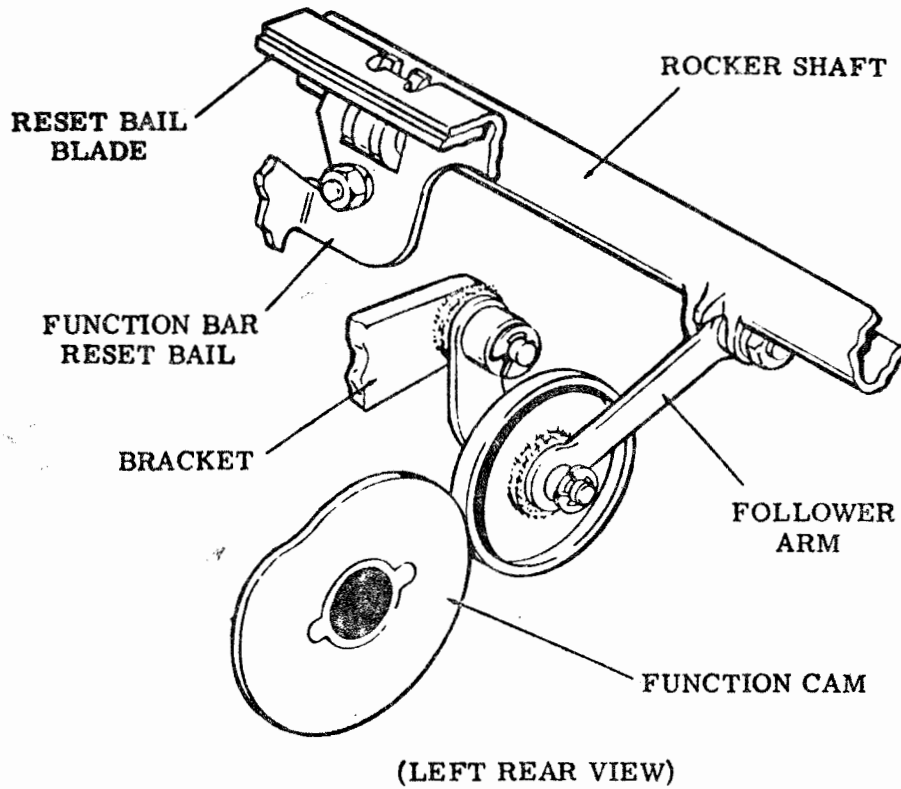

Figure 31 - Reset Bail Mechanism

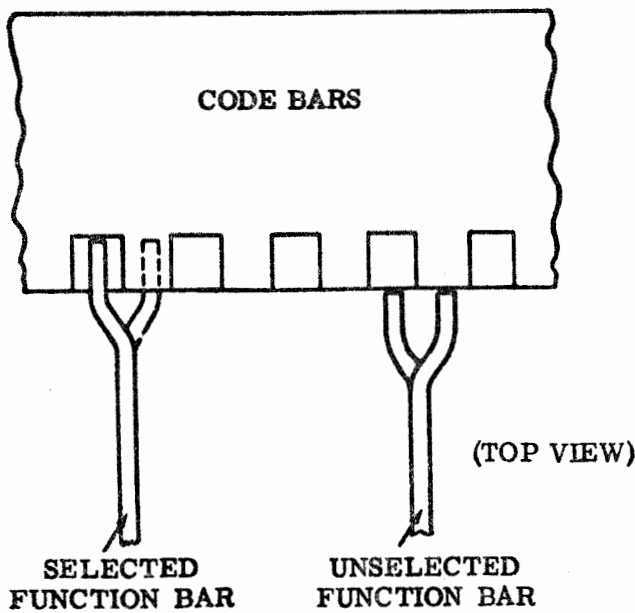

Figure 32 - Function Bar Selection

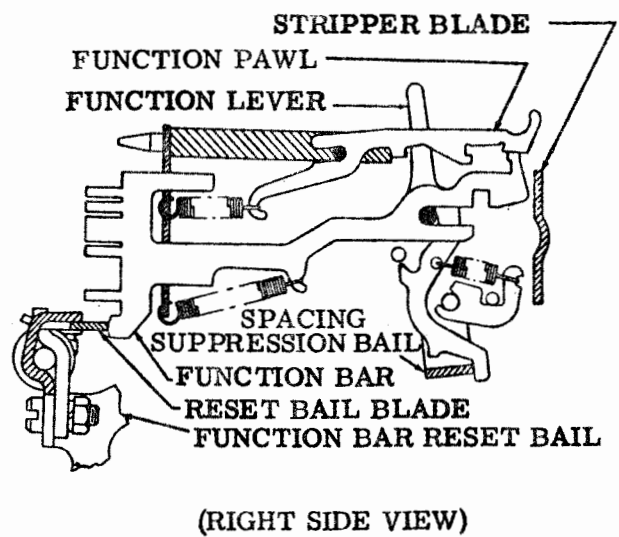

Figure 33 - Typical Function Linkage (Unselected)

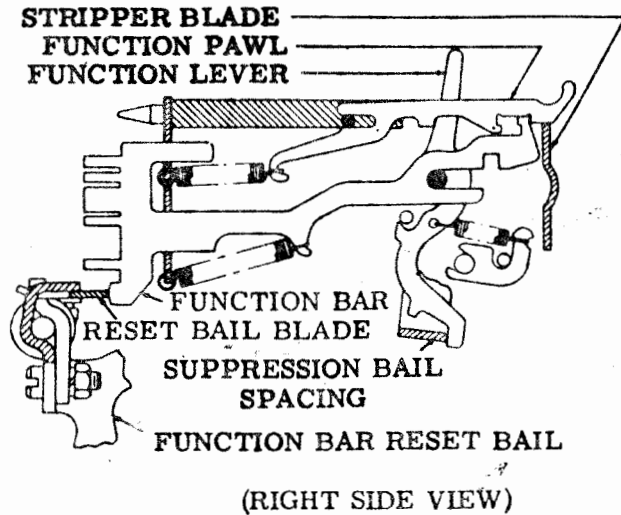

Figure 34 - Typical Function Linkage (Selected)

13.05 Near the end of the function cycle, a stripper blade (Fig. 30) operated by a cam on the function clutch assembly rises to engage any selected function pawl and strip it from its function bar. Springs return the released function pawl and the function lever to their original position. The function clutch is disengaged upon completion of one revolution when its latch lever falls into the indent of the clutch cam, in the same manner as described in connection with the code bar clutch (7.05).

CARRIAGE RETURN FUNCTION (Figs. 35 and 36)

13.06 The carriage return function mechanism is located in the right end of the typing unit. Reception of the input signal code combination for the function causes the function bar, pawl and lever to operate (Fig. 35). The lower end of the function lever engages the carriage return slide arm and pushes it forward. The slide arm, in turn, moves the carriage return bail and its lever about their pivot point. As the front portion of the lever moves downward, it takes with it the lower section of the spacing drum feed pawl release link. This causes the upper portion of the link to turn and disengage the spacing drum feed pawls from the spacing drum (Fig. 36).

13.07 When the carriage return lever reaches the lowest point, the carriage return latch bail locks it there. The disengagement of the spacing drum feed pawls from the spacing drum permits the spring drum to return the printing and type box carriages toward the left side of the typing unit. As the spacing drum nears the end of its counterclockwise rotation, the roller on the stop arm contacts the transfer slide which, in turn, drives the dashpot piston into the dashpot cylinder. A small passageway with an inlet from the inside of the cylinder and three outlets to the outside is incorporated in the end of the cylinder. Two of the openings to the outside are closed by a steel ball, which is held in its seat by means of a compression spring. A set screw which may be locked in place with a nut is used to regulate the spring pressure on the ball. The rate of deceleration provided by the cushioning effect of the trapped air is automatically regulated for various lengths of lines by means of the ball valve. This, together with the direct opening to the outside, determines the rate at which the air may escape from the cylinder. When the spacing drum reaches its extreme counterclockwise position, an extension on the stop arm trips the carriage return latch bail plate, which is fastened to the carriage return latch ball. The latch bail disengages the carriage return lever, and the feed pawls are again permitted to engage the spacing drum.

13.08 Local (off-line) operation of the carriage return mechanism may be obtained from the keyboard base or base on which the typing unit is mounted. A projection beneath the carriage return lever (Fig. 35), when rotated to the rear (counterclockwise, viewed from the right), operates the carriage return mechanism in the same way as when this lever is operated by the stunt box.

LINE FEED FUNCTION (Figs. 37 and 38)

13.09 The line feed function mechanism is located in the left end of the typing unit. The code bar mechanism set to correspond to an input signal code combination for spacing permits two line feed function bars, pawls and levers to operate. The function linkage at the far left of the stunt box (Fig. 37) operates the line feed mechanism. The lower end of the line feed function lever engages the line feed slide arm and pushes it forward. The slide arm, in turn, moves the line feed clutch trip arm and the trip lever above their pivot point until the trip lever releases the three stop line feed clutch. The line feed gearing is such that each

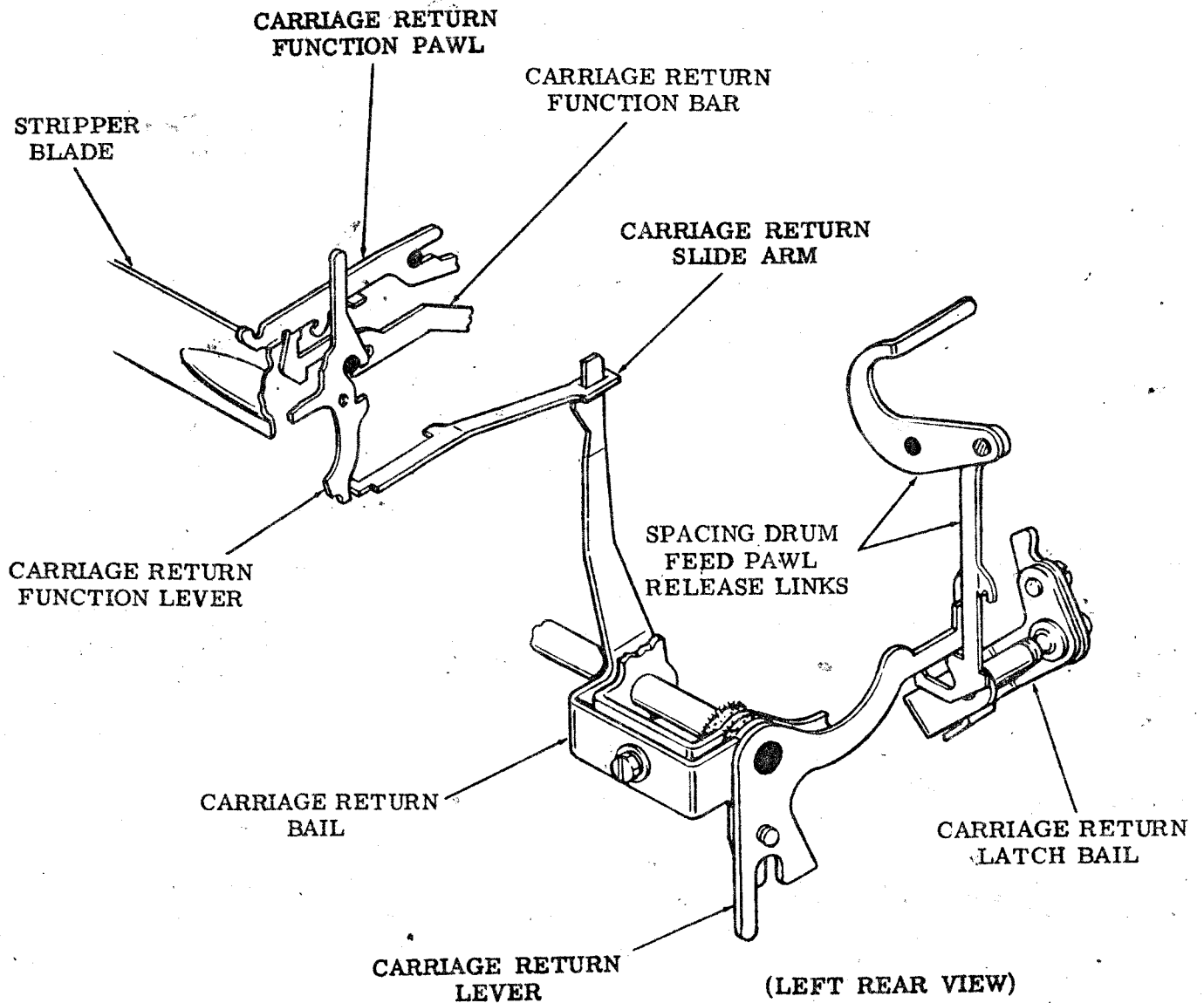

Figure 35 - Carriage Return Function Mechanism

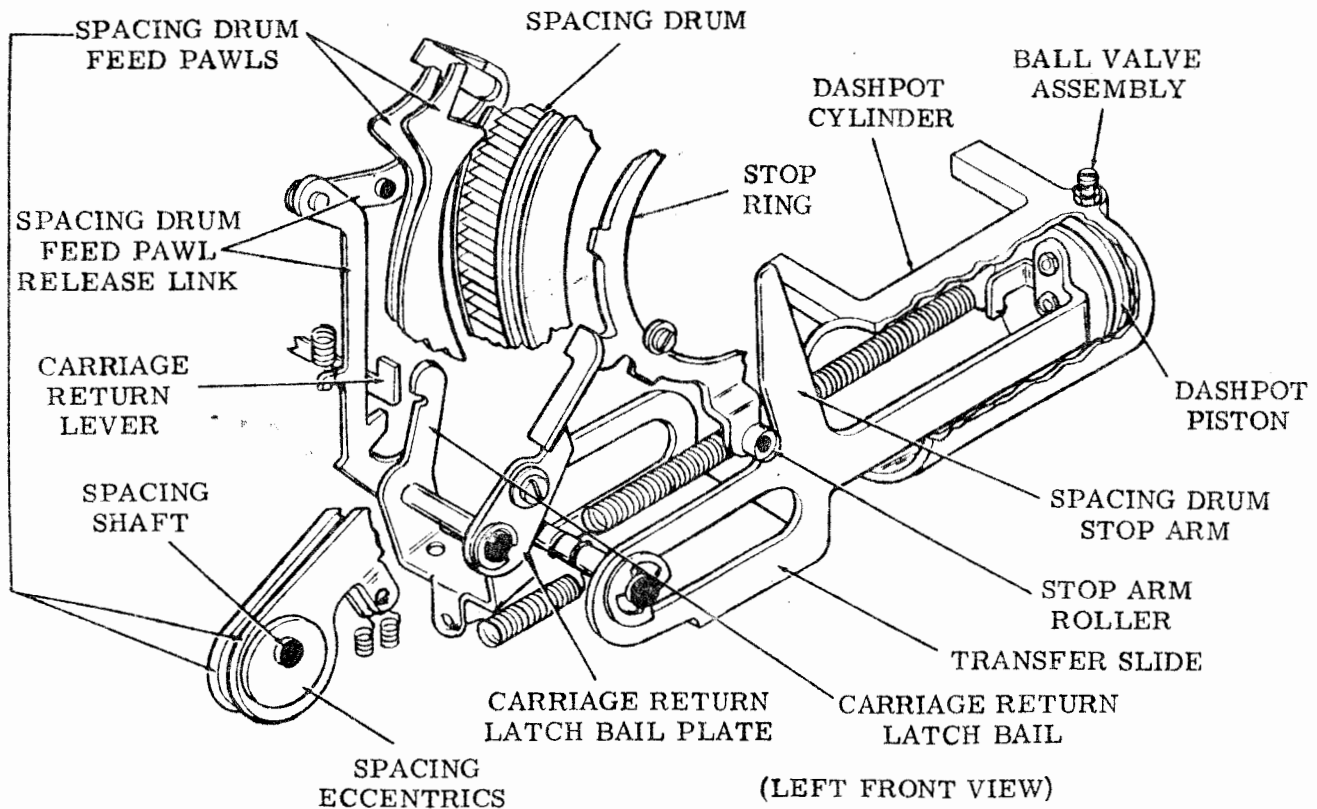

Figure 36 - Carriage Return Mechanism

one-third revolution of the clutch will advance the platen by one line. Therefore, the length of time that the line feed clutch trip lever is held away from the clutch will determine the number of line feeds that occur.

13.10 The timing relationship between the stripper blade cycle and the main shaft rotation is such that the function pawl is not stripped from a function bar until after more than one-third of a revolution of the clutch has occurred. Thus, the line feed clutch trip lever will stop the clutch after two-thirds of a revolution, or double line feed, has occurred. When single line feed is desired, it is necessary to strip the function pawl from the line feed function bar before the line feed clutch completes one-third of a revolution. This is accomplished by the use of an auxiliary function pawl stripper which is attached to the left end of the stripper bail. The cam disk on the three-stop line feed clutch provides the motive force to operate the stripper bail once each one-third revolution of the line feed clutch.

13.11 The stripper bail on which the slotted line feed function pawl stripper rides may be shifted toward the right (double) or to the left (single) by action of the single or double line feed lever (Fig. 37). The upper end of the pivoted single or double line feed lever protrudes from the upper left of the left side plate of the typing unit, where it rides in the two position side frame detent extension. When the lever is in position 1; the stripper bail engages line feed function stripper to raise it into contact with the function pawl before the stripper blade would strike it. When the lever is moved to the rear (position 2), the bail is disengaged from the blade, and the stripper blade strikes the function pawl in the normal cycling of the function box stripper blade.

13.12 When single line feed is being used, the line feed function lever is released too soon (by the line feed function pawl stripper) to prevent spacing. Therefore, an additional line feed function bar, pawl and lever are installed in a slot of the stunt box for the purpose of suppressing spacing on single line feed

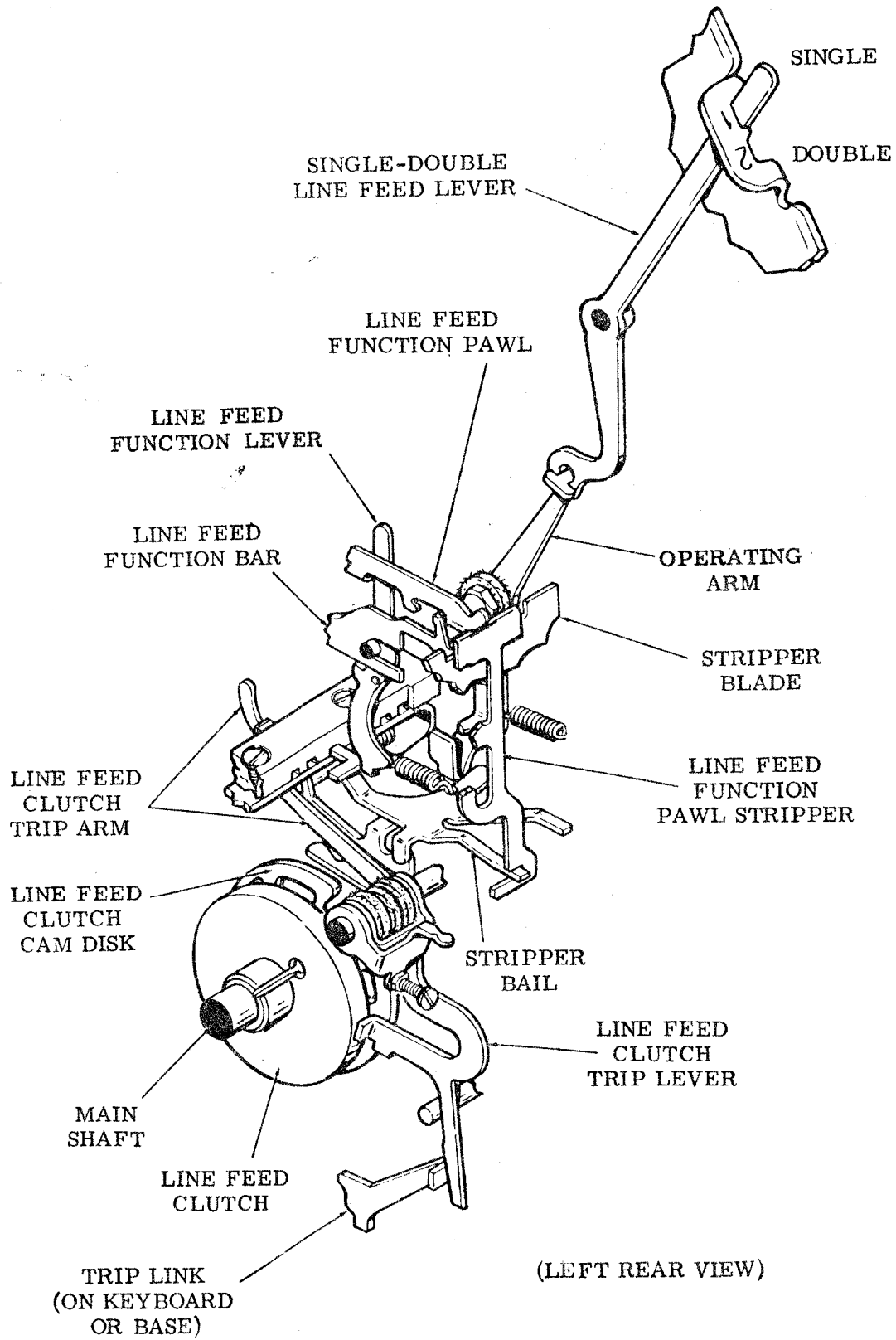

Figure 37 - Line Feed Mechanism

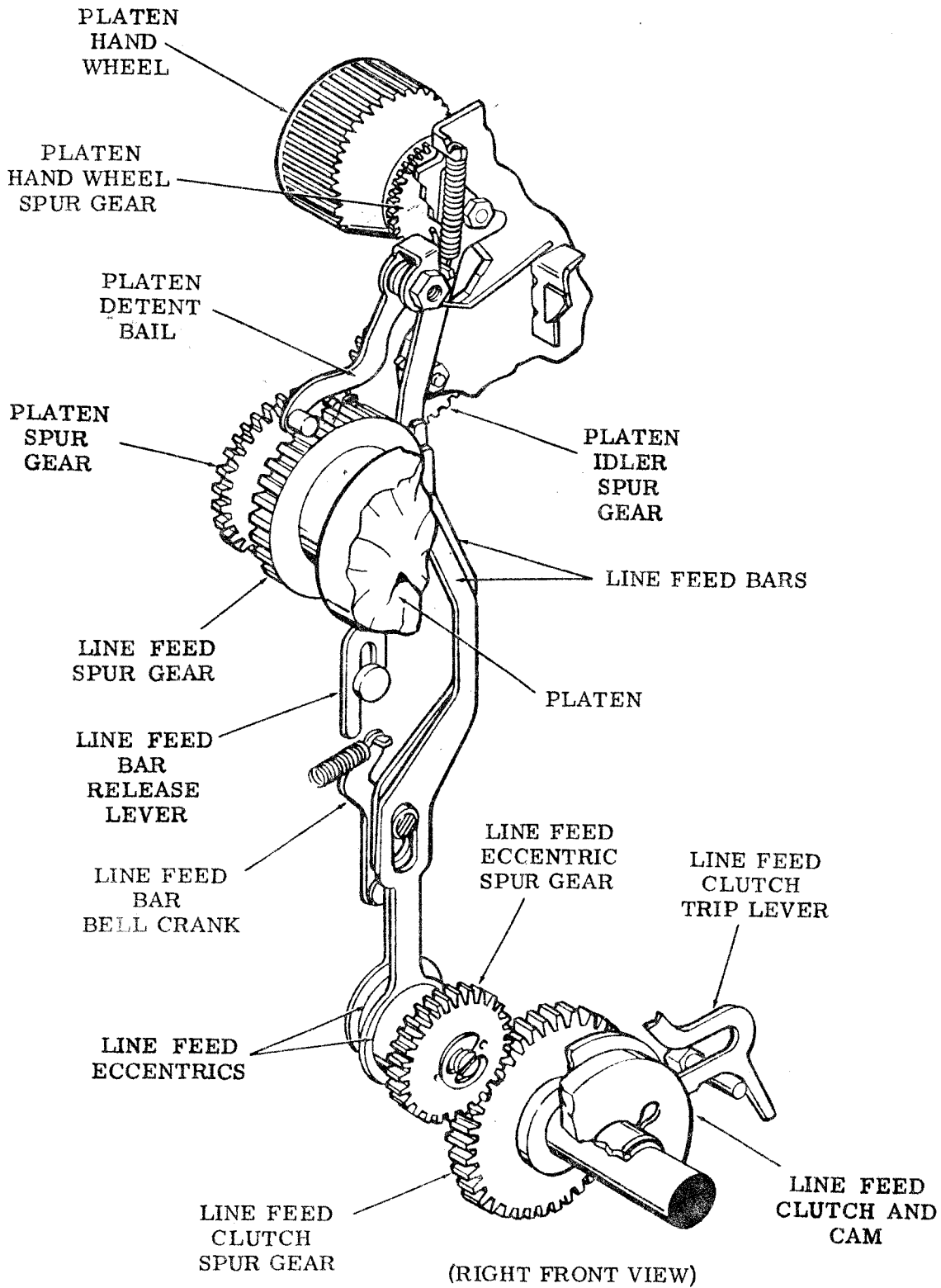

Figure 38 - Line Feed Mechanism

function. This mechanism, which always operates on the line feed function code bar arrangement, is released only by the stunt box stripper blade and, therefore, holds the spacing suppression bail operated (forward) until the spacing cycle is completed. After the line feed clutch is stopped by its trip lever, it is disengaged when the latch lever drops into the indent in the clutch cam, in the same manner as described in connection with the code bar clutch (7.05).

13.13 Each one-third revolution of the line feed clutch causes its attached spur gear (Fig. 38) to rotate the line feed eccentric spur gear and its attached eccentrics one-half of a revolution. The eccentrics, which are offset in opposite directions, each carry a line feed bar. These bars are guided by the line feed bar bell crank and alternately engage the line feed spur gear on the platen, advancing the platen one line for each one-half turn of the eccentrics. A platen detent bail engages the line feed spur gear to retain the platen at each setting.

13.14 When it is desired to position the platen manually, this may be accomplished by bearing down on and rotating the platen handwheel at the top of the right side plate. This causes the platen handwheel spur gear to engage the platen idler gear, which in turn is engaged with the platen spur gear on the platen shaft. At the same time, the line feed bar release lever (Fig. 38) bears on the line feed bar bell crank and causes it to disengage the line feed bars from the line feed spur gear.

13.15 Local (off-line) operation of the line feed mechanism may be obtained from the keyboard base or base on which the typing unit is mounted. A projection beneath the line feed clutch trip lever (Fig. 37), when rotated to the rear (counterclockwise, viewed from the right), operates the line feed mechanism in the same way as when this lever is operated by the function box. Since the clutch is manually engaged, line feed is continuous until released at the keyboard or base.

LETTERS-FIGURES SHIFT FUNCTION (Fig. 20)

13.16 Upon reception of the letters or figures signal code, the letters and figures function bars, pawls and levers initiate the letters or figures shift (8.05). The upper ends of the function levers engage the letters and figures function slides (Fig. 20). The front ends of these function slides have camming surfaces which,

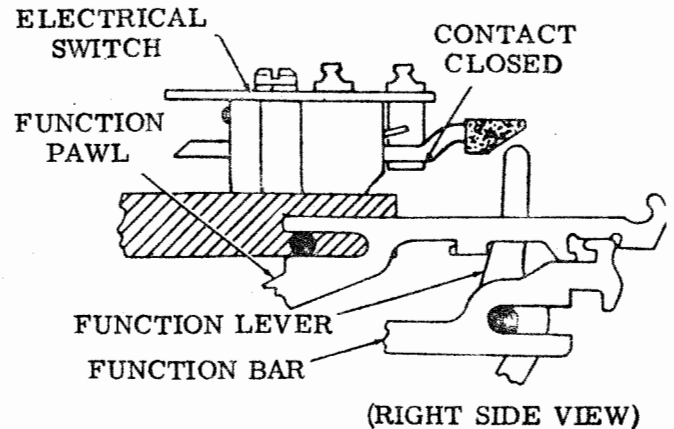

Figure 39 - Typical Stunt Box Contact (Unoperated)

when a slide is shifted to the rear by its function lever, move the letters-figures code bar fork to the right (letters position) or to the left (figures position). The fork engages a pin on the bracket which is fastened to the letters-figures shift code bar, and positions the code bar to the right or left (Fig. 20). Movement of the letters-figures code bar results in the positioning of the type box, through related mechanisms, for printing of letters or figures, as described in 8.05.

STUNT BOX CONTACTS (Figs. 39 and 40)

13.17 For external circuit control and switching functions, the function levers may be positioned to operate normally open, normally closed, or SPDT switches mounted on the top of the stunt box. In general, the function contacts are similar except for electrical connections,

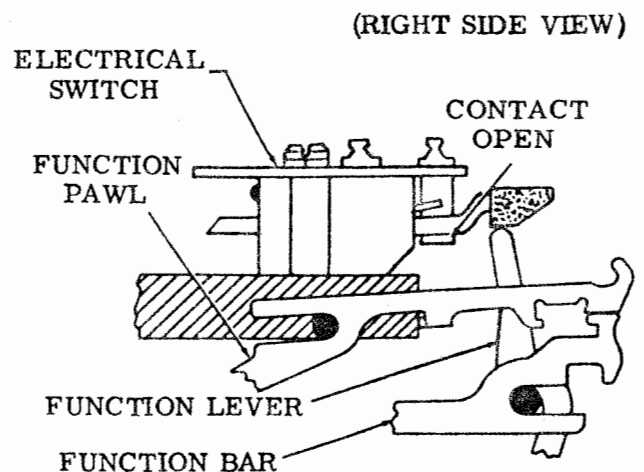

Figure 40 - Typical Stunt Box Contact (Operated)

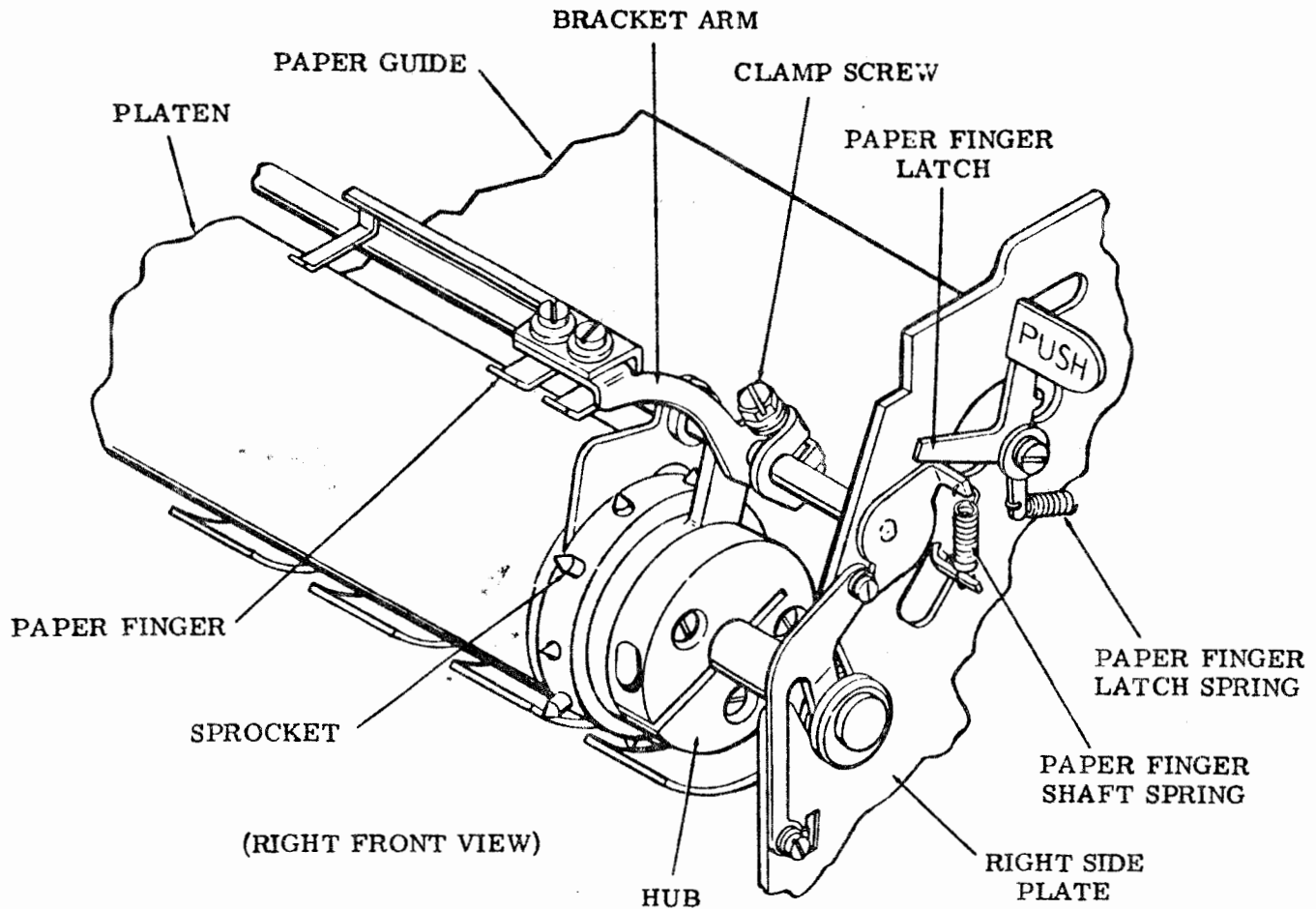

Figure 41 - Sprocket Feed Platen Mechanism

which are determined by external requirements. The contact arm configuration is changed as required to either make or break the contact when the associated function lever is in selected (rear) position. All contacts are wired through the cable connector located on the right side plate. A typical contact (NO) is illustrated in unselected (Fig. 39) and selected (Fig. 40) condition.

14. SPROCKET FEED TYPING UNIT

GENERAL (Figs. 3 and 41)

14.01 Except for differences in the platen and associated mechanisms (par. 2), the sprocket feed typing unit includes all features of the friction feed typing unit described in this section. It has a sprocket feed mechanism for insertion of a form-fold paper supply for the page printed message.

DESCRIPTION

14.02 The platen is equipped at each end with an eleven pin sprocket, with pins spaced to accommodate holes along the edges of form fold paper for the page printed message (Fig. 41). The pins are cammed (within the platen) so that the two bottom and two top pins on each side at the front of the platen are extended, while all others are retracted. Extended pins engage the holes in the form fold and pull the paper into page printing position over the front of the platen, where it is held by two paper fingers. At the rear of the platen, the form fold is fed through an aperture at the back of the enclosure housing the typing unit, across a flat paper guide, and under the bottom of the platen. Paper feeding and line feeding are as described in 13.09. Paper fingers are released to a spring loaded upright position by pushing a lever marked PUSH on the top of the right side plate to the rear. The fin-

gers are repositioned by depressing them manually until the end of the paper guide shaft latches an indent on the release lever.

15. VARIABLE FEATURES

HORIZONTAL TABULATION (Figs. 42 and 43)

15.01 The spacing drum for typing units equipped for horizontal tabulation has a slotted tab stop ring mounted over the face of the spacing drum, in place of the carriage return ring on other units. The ring (Fig. 42), when coded for the desired tabulation, will allow the carriage to be moved rapidly, at a speed three times that of normal spacing, to predetermined horizontal positions on the printed page.

15.02 Reception of the input signal code combination representing horizontal tabulation operates the associated stunt box mechanisms to move the function lever forward. The function lever moves the horizontal tabulator slide (Fig. 43) forward. As the slide arm moves forward, it engages the operating lever cam plate, causing the operating lever to pivot about its mounting stud, located at the center of the lever. As the upper end of the operating lever moves forward, the extension link attached to the lower end of the lever moves to the rear. Near the end of its travel, the extension link clears the blocking lever, allowing it to move down into position to block the link from moving forward.

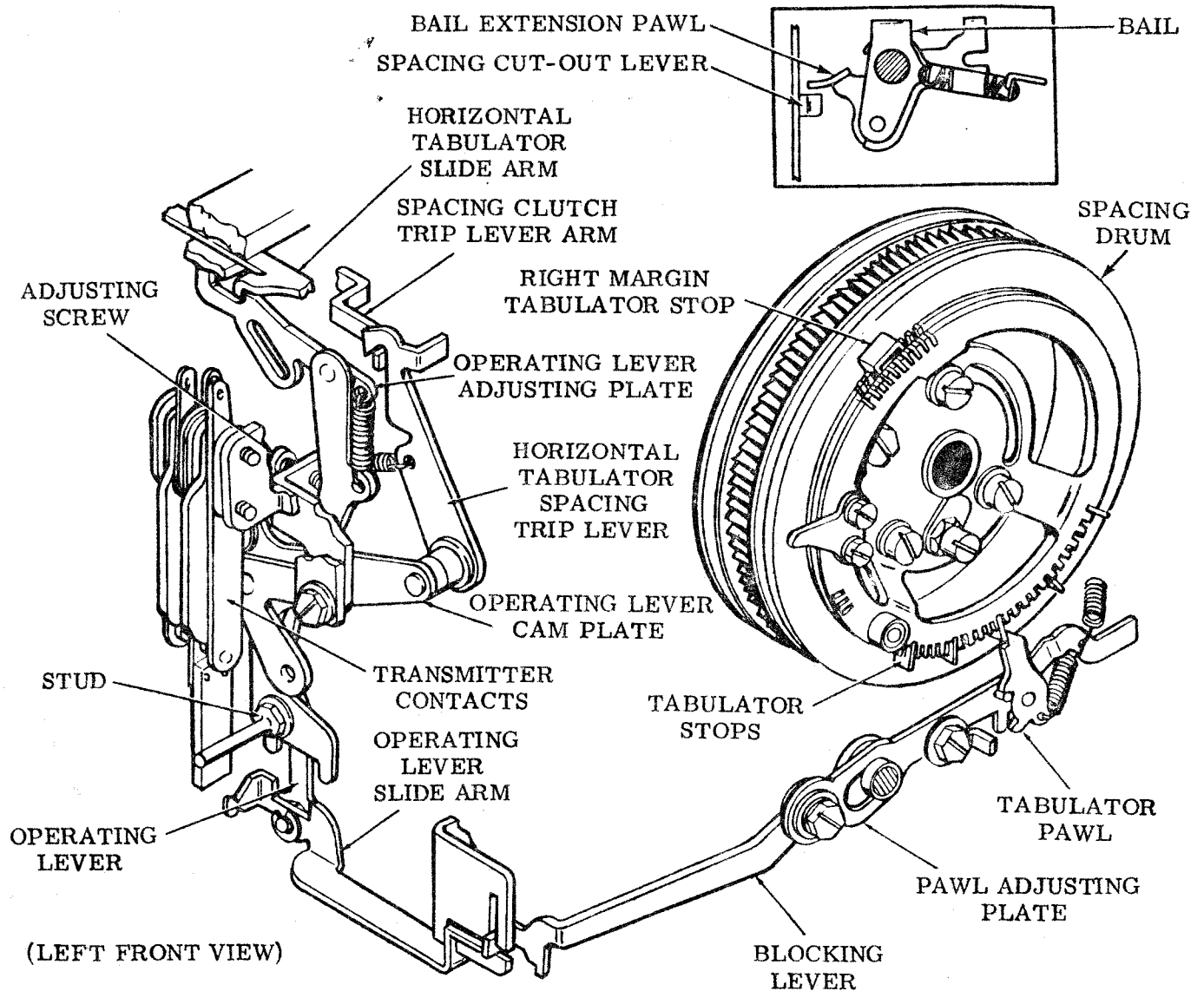

Figure 42 - Horizontal Tabulation Mechanism

15.03 Tripping of the spacing clutch is initiated in the same way as for normal printing (10.01-10.02). As the trip lever moves down, however, it hooks over and pulls down the intermediate trip bail (Fig. 43). The intermediate ball in turn pulls down the stop lever arm and trips the clutch stop lever, which is clamped to the lower end of the stop arm. The spacing clutch then starts to rotate. The stop lever arm in its unoperated position rests against the intermediate bail.

15.04 Fastened to and moving as part of the operating lever is the latch bail adjusting plate (Fig. 43). Mounted to the stud on the upper end of the adjusting plate is the stop lever arm latch bail. The latch bail in its rest position is held forward by spring tension against a projection on the adjusting plate. Therefore, when the upper end of the operating lever moves forward, the latch bail moves with it until the upper end of the latch bail strikes the spacing stop lever arm, which would not have been pulled down yet. The operating lever continues moving until it reaches its forward position, but the latch bail resting against the stop lever arm is prevented from going any farther and pivots around its mounting stud. Later, when the stop lever arm is pulled down by the spacing trip lever, the forward end of the stop lever arm comes below the latching surface of the latch bail. The latch bail then moves forward over the stop lever arm, latching it down as long as the operating lever is held in its operated position.

15.05 As the spacing clutch starts to rotate, the cam plate stripper bail (Fig. 43) engages the cam lobe on the spacing clutch restoring cam. This pivots the stripper bail about its shaft, causing the operating lever cam plate to be pivoted downward, out of engagement with the slide arm. The operating lever then drops back slightly until the lever extension link butts up against the blocking lever, which is in the down position. Thus, the operating lever is held operated, the spacing stop lever arm is latched down by the latch bail, and the spacing clutch will rotate until the blocking lever is tripped, unblocking the operating lever extension link.

15.06 As the spacing clutch rotates, the spacing drum will rotate until a tab stop attached to the drum reaches the tabulator pawl mounted on the blocking lever (Fig. 42). As the tab stop moves across the pawl, the pawl is moved down, causing the blocking lever to rotate about its mounting stud and releasing the operating lever extension link. The operating lever

returns to its unoperated position. The latch bail releases the stop lever arm, and the clutch stop lever blocks further rotation of the spacing clutch. The tabulator function slide arm returns to its unoperated (rear) position when the function pawl is stripped from the function bar during the normal operation of the function stripper blade.

15.07 When the printing carriage nears the right margin position, the spacing cut-out lever (Fig. 42) on the spacing drum engages the lower surface of the bail extension pawl. The extension pawl and bail rotate together due to the pawl spring until the bail is fully operated. When the transfer bail is in its operated position, the space suppression slide is operated, and further normal spacing is prevented. If the clutch were to continue to rotate, the spacing drum will continue to rotate after the transfer bail reaches its operated position. At this time, the bail reaches a fixed stop, but the extension pawl pivots about the lower pivot point, permitting the cut-out lever on the drum to go by the pawl. The transfer bail and the extension pawl will then return to their unoperated position. When the carriage returns, the space cut-out lever engages the upper surface of the extension pawl, causing the pawl to pivot about the mounting shaft until the cut-out lever is able to go by the pawl. The extension pawl is then returned to its unoperated position.

15.08 A set of contacts, the forward contacts interrupting operation of an associated transmitter distributor set during the tabulation operation, the rear operating a motor hold mechanism external to the typing unit, are operated simultaneously when the operating lever is in operating position.

VERTICAL TABULATION AND FORM OUT (Fig. 44)

15.09 A number of form starter gears and index discs (Fig. 44) are available to adapt sprocket feed typing units for form out accommodation of forms two to fifteen inches in length with vertical tabulation in 1-inch increments, or of two to ten inches in length with vertical tabulation in 1/2 inch increments. The form starter gear and the index disc are selected for the desired form length. The form out mechanism automatically advances a form to the first printing line on the succeeding form from any point on the previous form. The vertical tabulation mechanism advances a form to any predetermined position within the form.

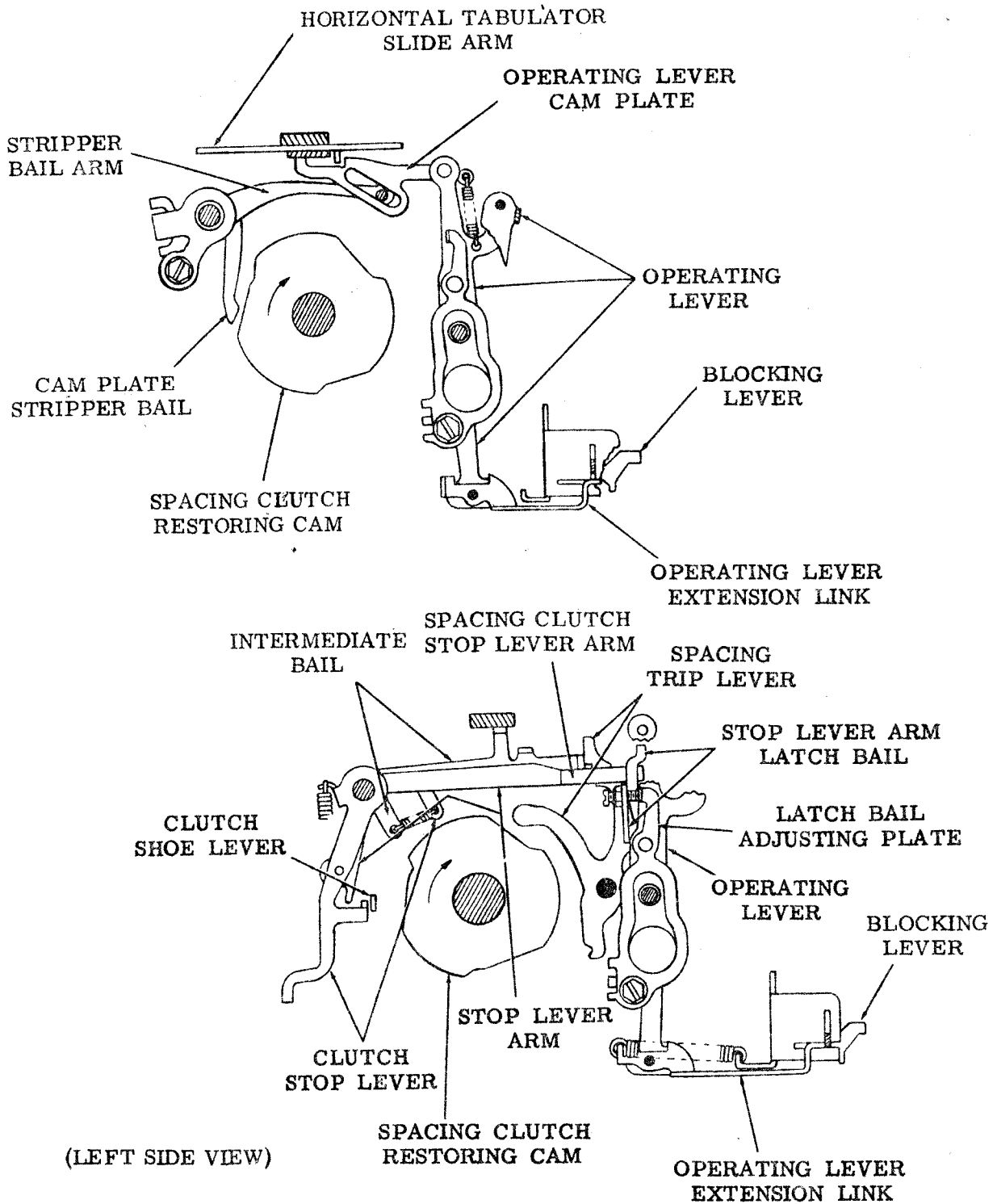

Figure 43 - Horizontal Tabulation

15.10 When the input signal code combination representing form out is received, the associated stunt box mechanism linkage moves the form out slide forward. As a result, the tabulator slide moves forward, moving the line

feed slide forward so that it unlatches the line feed clutch. With the line feed clutch engaged, movement of the form out slide is prevented by the form out blocking lever, and the line feed mechanism operates continuously.

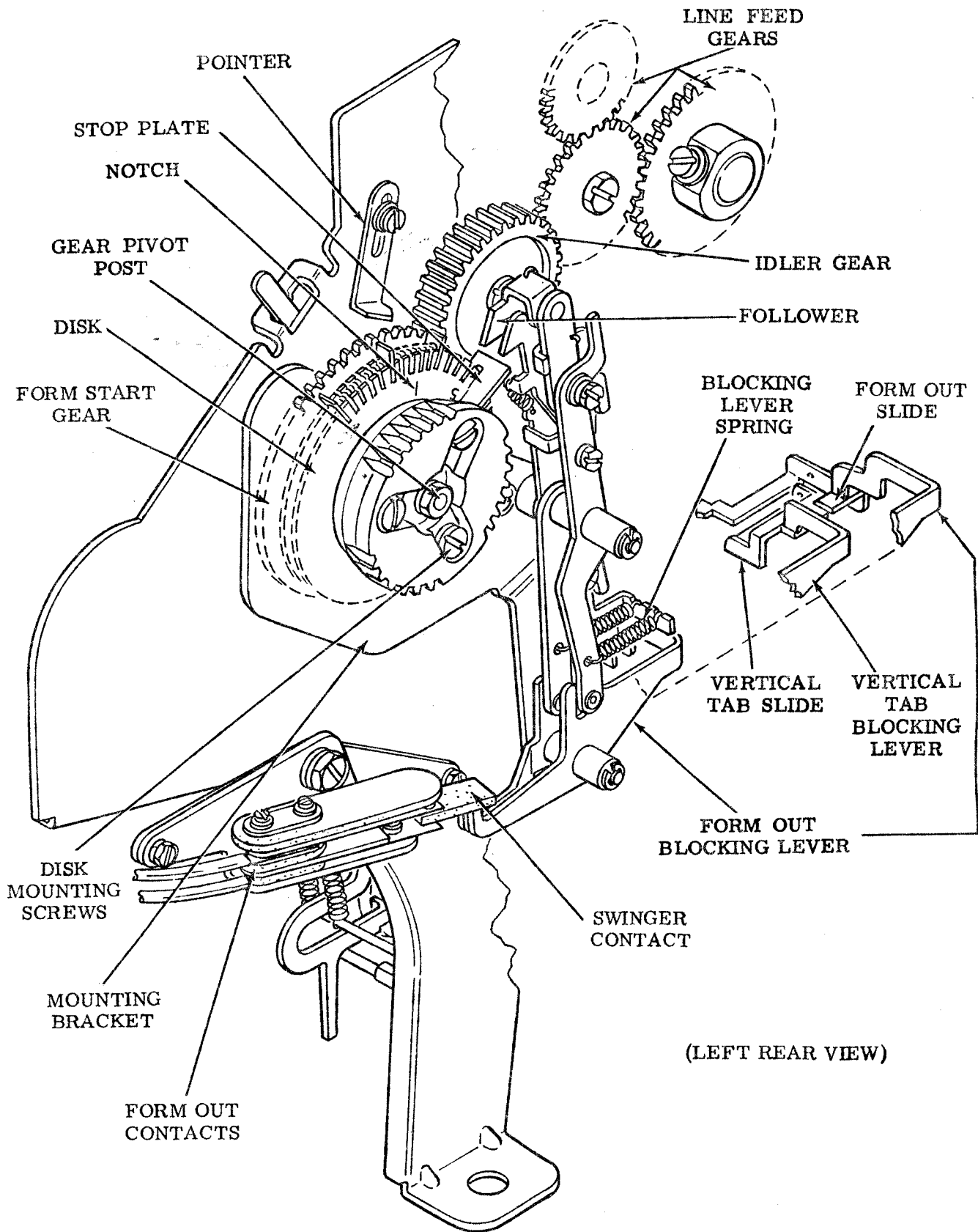

Figure 44 - Vertical Tabulation and Form Out Mechanisms

15.11 When the stop plate on the rotating disc engages the pawl, the form out blocking lever is moved upward, permitting the slides to return to their unoperated positions. When this occurs, the line feed clutch is disengaged, and the form out operation is terminated.

15.12 The sequence of operation of vertical tabulation is similar to that of the form out mechanism. When the input signal code combination representing vertical tabulation is received, the associated stunt box mechanism operates a vertical tabulator slide. The slide, moving forward, engages the line feed slide, which in turn engages the line feed clutch. The vertical tabulator blocking lever retains the vertical tabulator slide in the operated position, and the line feed clutch is permitted to rotate continuously.

15.13 The vertical tabulator slide remains in the operated position until the stop plate on the disc engages the bail, which in turn raises the blocking lever and allows the vertical tabulation slide and the line feed slide to return to their unoperated positions. The line feed clutch is disengaged, and the function mechanism is stripped to its unoperated position.

15.14 A set of transmitter control contacts operate on both vertical tabulation and form out cycling. The contacts contain an insulated swinger that rides on an extension of each blocking lever. When either blocking lever is in the operated position, the contacts are opened and, through external wiring, stop transmission from the associated transmitter-distributor.

AUTOMATIC CARRIAGE RETURN-LINE FEED

15.15 The automatic carriage return-line feed feature operates through stunt box mechanism each time the type box carriage advances to within one character of the right margin. Should an operator fail to originate these functions, this feature provides them automatically.

15.16 With the type box carriage advanced to within one character of the right margin, the automatic carriage return bell crank is tripped by an arm attached to the spacing drum (Fig. 26). The bell crank turns clockwise and positions the automatic carriage return-line feed code bar, marked O, to the right. Two identical function bars, each with a single code projection are provided in the stunt box, adjacent to the carriage return and line feed function bars. The code bar normally blocks the

function bars. When the automatic carriage return-line feed code bar is positioned to the right, however, the function bars and their associated pawls and levers operate. The carriage return and line feed slide arms are operated, and cause these functions to occur simultaneously.

LOCAL BACKSPACE

15.17 Each time the LOC BSP (local backspace) key lever on the associated keyboard unit is operated, a backspace occurs at the local typing unit. The key lever, through an operating bail and trip link engages the spacing clutch. As the spacing eccentric assembly rotates, the spacing feed pawl that is moving upward is prevented from engaging the teeth on the spacing drum by the action of the eccentric and the pivoting of the feed pawl on the back space camming bail. As a result, the spacing drum rotates backward under spring tension, following the feed pawl that is moving downward. After a single backspace occurs, the spacing clutch is disengaged by action of the trip link stripper, which rides on the clutch cam disc.

UNSHIFT ON SPACE

15.18 Each time the space function signal code is received, the unshift on space feature automatically shifts the type box to the letters position. A function bar and its function lever, located adjacent to the letters-figures function mechanism, operate upon receipt of the space signal code. The function lever engages an extension of the letters function slide. Therefore, when a spacing function occurs, letters shift will also occur, in the manner described in 8.05. This feature may be disabled by the adjustment of a screw which raises the end of the function pawl from the function bar.

SIGNAL BELL

15.19 The circuit to the signal bell magnet is controlled by a set of normally-open electrical contacts operated by the stunt box. The function bar for the signal bell function has six code lugs, five for the signal code combination, such as S or J, and one for the letters-figures shift code bar. To select the signal bell function, the letters-figures shift code bar must be in or shifted to the figures position. Then, each time the signal code combination for the bell function is received, the function lever will pulse the signal bell contact. If the letters-figures code bar is in the letters position at this time, it will block the signal bell function bar.