

KEYBOARD TAPE PUNCH AND
KEYBOARD TYPING TAPE PUNCH (OFF-LINE)

ADJUSTMENTS

CONTENTS	PAGE	CONTENTS	PAGE
1. GENERAL	3	Function Clutch Trip Mechanism	
2. ADJUSTMENTS	5	Main trip lever spring (early design)	10
Character Counter Mechanism		Punch and feed slide latch springs	10
Antibounce spring	39	Trip lever release spring (early design)	10
Character counter end-of-line switch	40	Function Mechanism	
Character counter scale	39	Cam follower roller	11
Character counter stroke	41	Cam follower roller alignment	11
Ratchet drum assembly return spring	40	Clutch shoe lever	5
Reset latchlever and drive lever spring	41	Clutch shoe lever spring	8
Reset lever extension spring	41	Clutch shoe spring	8
Stop lever	39	Function clutch drum endplay	5
Clutch Release Lever Mechanism		Function clutch drum endplay (for units equipped with two shafts)	5
Clutch release lever (early design)	43	Function clutch latchlever spring	7
Clutch release lever (late design)	44	Function clutch release lever spring	9
Clutch release lever and trip lever alignment (early design)	42	Function clutch reset lever and latchlever	7
Codebar and slide latch	42	Function clutch stop lever	6
Punch slide latch clearance	45	Release downstop bracket	9
Trip lever release backstop (early design)	43	Keyboard Guideplate	
Codebar Mechanism		Endplate clearance	77
Codebar bail latch	47	Keyboard clearance	77
Codebar return arm bracket	46	Keyboard Mechanism	
Codebar return cam follower bracket	46	Ball-lock-wedge, ball endplay and universal bail latch (final)	34
Cover		Ball wedge lock and ball track clearance (preliminary)	32
Copyholder	78	Clutch tripbar spring (even parity)	30
Lid	78	Clutch tripbar spring (nonparity)	29
Punch window	78	Codebar and codelever clearance (nonparity and even parity)	29
Tape guideplate	78	Codebar guide clearance	28

CONTENTS	PAGE
Codebar reset bail	36
Codebar reset bail and nonrepeat lever	37
Codebar reset bail latch spring	36
Codebar reset bail spring	35
Codebars, shift and control lockbar, counter and counter return bar springs (even parity)	30
Codebars, shift lockbar and inversion bar spring (nonparity)	29
Codelever universal bail spring	28
Function bail levers and codelever clearance	31
Inversion bar latching bail spring (even parity)	38
Inversion codebar latch (even parity)	38
Lock ball channel	31
Lock ball channel endplay (preliminary)	32
No. 5 and no. 8 inversion bar springs (even parity)	30
Nonrepeat lever spring	37
Spacebar bail pivot	28
Universal bail extension	34
Universal bail latchlever (preliminary)	33
Universal bail latch spring	33
Universal bail rear blade	34
 Motor	
 Motor pinion and gear backlash.	47
 Power Drive Backspace Mechanism	
Armature bail spring (early design)	27
Armature latch spring (early design)	27
Armature hinge (early design)	23
Armature spring (late design)	26
Armature upstop (early design)	24
Backspace pawl clearance	22
Backspace ratchet	22
Bellcrank spring	27
Drive link (early design)	24
Feed pawl eccentric (preliminary)	23
Feed pawl spring	27
Final power adjustment (late design)	26
Latch (early design)	25
Latch extension (early design)	24
Latch extension spring (late design)	26

CONTENTS	PAGE
Magnet position (late design)	26
Nonrepeat arm (early design)	25
 Punch Mechanism	
Bias spring (punch block)	21
Bias spring (tape chute)	21
Detent lever spring	18
Feed pawl	17
Feed pawl spring	18
Latchlever clearance	17
Lateral and front to rear feed wheel position detent	20
Perforator drive link spring	13
Punch mounting plate (final)	12
Punch mounting plate (final) (typing)	14
Punch mounting plate (preliminary)	12
Punch pin penetration	16
Punch slide downstop position	16
Punch slide guide (final)	16
Punch slide spring	21
Reset bail trip lever (final)	15
Tape guide assembly spring	21
Tape shoe torsion spring	18
Ten characters per inch (final)	19
Ten characters per inch (preliminary)	19
Toggle bail eccentric (preliminary)	13
Toggle operating arm	13
 Ribbon Shift and Print Suppression Mechanism	
Armature air gap (early design)	69
Armature air gap and downstop (late design)	70
Armature downstop (early design)	69
Armature spring (early design)	69
Armature spring (late design)	70
Armature upstop (early design)	69
Armature upstop (late design)	70
Blocking link (late design)	70
Ribbon carrier (late design)	68
Ribbon carrier spring (late design)	68
Ribbon shift and print suppression contacts (early design)	53
Ribbon shift and print suppression contacts (late design)	55
Ribbon shift and print suppression contact position (early design)	54
Ribbon shift and print suppression contact position (late design)	56

CONTENTS	PAGE
Typing Mechanism	
Accelerator latch spring	72
Alignment (preliminary)	48
Axial corrector (yielding)	62
Axial output rack guide roller	64
Axial sector alignment	63
Bellcrank pushbar engagement	51
Bellcrank springs 1 to 5	48
Bellcrank springs 6 and 7	49
Bellcrank spring 8	48
Cam follower roller arm position	57
Centering clearance	50
Correcting drive link spring (nonyielding)	60
Correcting drive link (nonyielding)	65
Corrector drive link (yielding) extension spring	62
Detent spring	76
Drive arm	75
Drive arm spring	76
Eccentric shaft detent lever spring (6)	63
Feed pawl spring	75
Function blade spring	60
Lifter operating range	57
Lifter spring	60
Lifter toggle link spring	60
Oscillating bail drive link	61
Oscillating bail pivot	61
Print hammer	73
Print hammer accelerator spring	72
Print hammer return spring	72
Print hammer trip lever spring	72
Printing latch	71
Pulse lever spring no. 5	50
Pulse lever spring no. 7	50
Pushbar guide bracket	64
Pushbar location	52
Ratchet wheel torque spring	75
Rotary corrector arm	67
Rotary corrector mesh	66
Shoulder clearance	49
Toggle link	58
Toggle trip arm	59
Typewheel (final)	74
Typewheel (preliminary)	74
Typewheel rack clearance	65
3. VARIABLE FEATURES	
Print Suppression Mechanism	
Accelerator blocking link (early design)	80
Accelerator blocking link (late design)	79

1. GENERAL

1.01 This section provides adjustments for the keyboard tape punch and keyboard typing tape punch. It is reissued to add engineering changes and to rearrange the text. TCN1299 has been incorporated in this reissue. Since this is a general revision, marginal arrows ordinarily used to indicate changes and additions are omitted.

1.02 In the adjustments and spring tensions, covered in this section, location of clearance, position of parts, and point and angle of scale applications are illustrated by line drawings. Requirements and adjustment procedures are set forth in the text that accompany the drawings. A procedure should be read all the way through before making the adjustment or testing the spring tension.

1.03 It is assumed that the elements depicted in the illustrations are being viewed from a position in front of the equipment, unless they are specifically labeled otherwise. In the line drawings, pivot points are shown by circles which are solid black.

1.04 Tools required to make the adjustments and test the spring tensions are not supplied with the equipment.

1.05 The adjustments are arranged in a sequence that should be followed if a complete readjustment of the unit is undertaken. If parts are removed, all adjustments which the removal of these parts might facilitate should be made before the parts are replaced. Unless specifically stated to the contrary, after an adjustment has been made, all nuts and screws that were loosened should be tightened.

1.06 The spring tensions given in this section are indications, not exact values, and should be checked with scales in the positions shown in the drawings. Springs which do not meet the requirements and for which there are no adjusting procedures should be discarded and replaced with new springs. The spring tensions can be tested in any sequence.

1.07 The adjustments pertaining to the typing mechanism are peculiar to the keyboard typing tape punch. All other adjustments including the punch mechanism, character counter mechanism, powered backspace mechanism, keyboard mechanism and clutch mechanism are

SECTION 570-223-700

common to both the keyboard tape punch and the keyboard typing tape punch. Where a difference in an adjustment requirement occurs, a notation on the page indicates that the adjustment pertains to either the keyboard tape punch or to the keyboard typing tape punch.

1.08 When a requirement calls for the clutch to be disengaged, the clutch shoe lever must be fully latched between its trip lever and latchlever so that the clutch shoes release their tension on the clutch drum. When engaged, the

clutch shoe lever is unlatched and the clutch shoes are wedged firmly against the clutch drum.

Note: When rotating the main shaft by hand, the clutch does not fully disengage upon reaching its stop positions. In order to relieve the drag on the clutch and permit the main shaft to rotate freely, apply pressure on a lug of the clutch disc with a screwdriver to cause it to engage its latchlever and thus disengage the internal expansion clutch to prevent the clutch shoes from dragging on the clutch drum.

2. ADJUSTMENTS

2.01 Function Mechanism

Note: These adjustments to be made prior to mounting perforator assembly to keyboard.

FUNCTION CLUTCH DRUM ENDPLAY (For Units Equipped With Two Shafts)

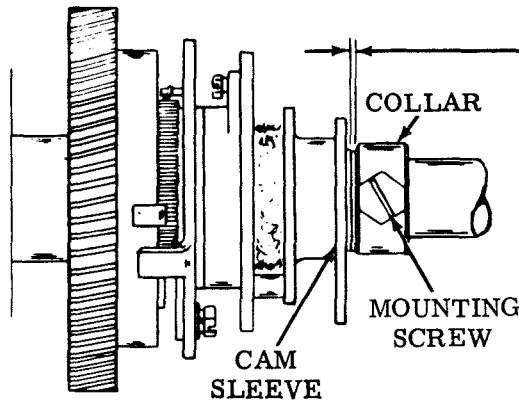

Requirement

Function clutch disengaged
Min some---Max 0.015 inch endplay between cam sleeve and collar when play is taken up to make clearance a maximum.

To Adjust

Position collar with mounting screw loosened.

FUNCTION CLUTCH DRUM ENDPLAY

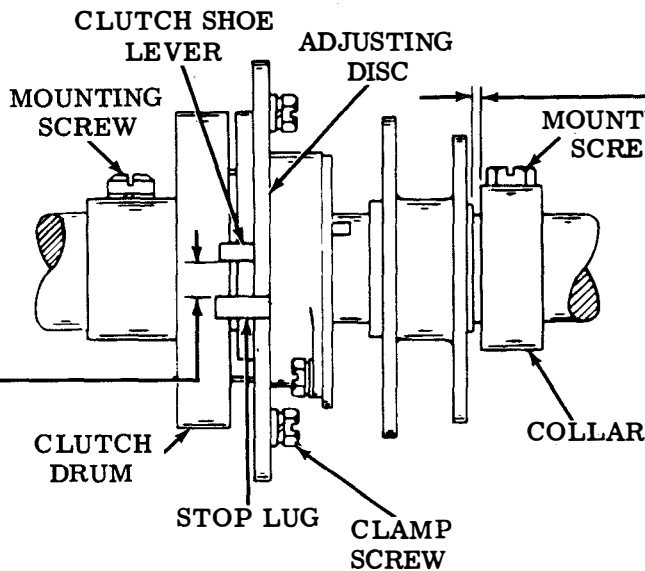

Requirement

With function clutch disengaged
Min some---Max 0.015 inch when play is taken up to make clearance maximum.

To Adjust

With its mounting screw loosened, move drum to extreme front position. Tighten drum mounting screw. Position collar with mounting screw loosened.

CLUTCH SHOE LEVER

To Check

Disengage clutch and measure gap. Align head of drum mounting screw with stop lug. Engage clutch. Manually press shoe lever against stop lug and allow to snap apart. Measure gap with clutch engaged.

Requirement

Gap between clutch shoe lever and its stop lug should be
Min 0.055 inch---Max 0.085 inch
greater when clutch is engaged than when clutch is disengaged.

To Adjust

Engage wrench or screwdriver with lug on adjusting disc. Rotate disc with clamp screws loosened.

Note: After making adjustment, disengage clutch. Remove drum mounting screw. Rotate drum in normal direction and check to see if it drags on shoe. If it does, refine adjustment.

2.02 Function Mechanism (continued)

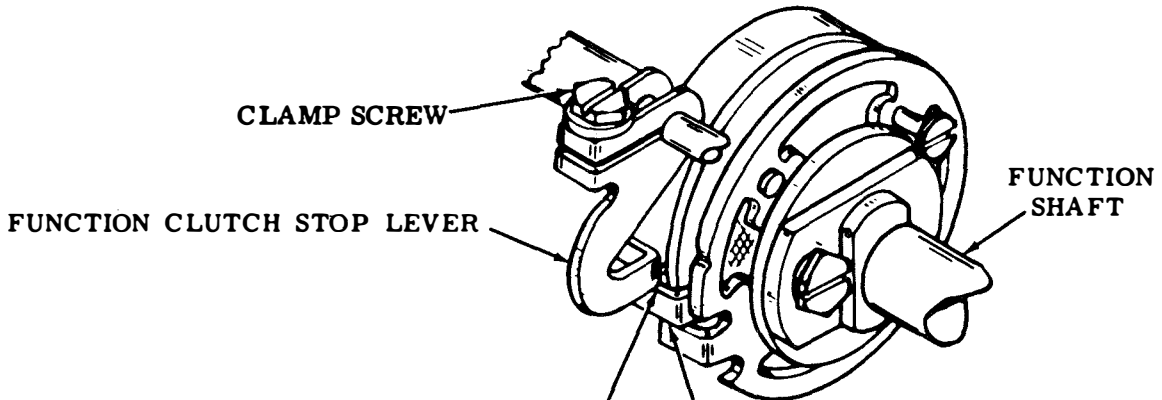

FUNCTION CLUTCH STOP LEVER

(1) Requirement
With release lever resting on top of trip lever (see FUNCTION CLUTCH RESET LEVER AND LATCHLEVER (2.03) adjustment), the function clutch stop lever should engage the clutch shoe lever by the full thickness of the shoe lever.

(2) Requirement
Min some---Max 0.006 inch
endplay in function clutch stop lever.

To Adjust
Position the stop lever on its shaft with its clamp screw friction tight. Tighten screw.

FUNCTION CLUTCH STOP LEVER

(Right Side Views)

2.03 Function Mechanism (continued)

(A) FUNCTION CLUTCH RESET LEVER AND LATCHLEVER

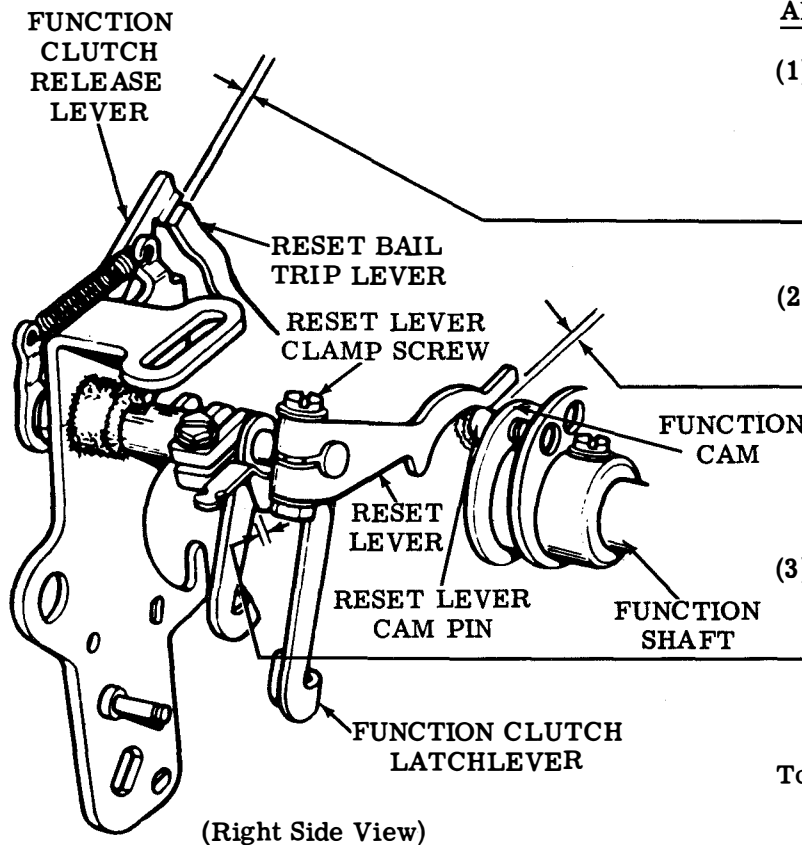

(Right Side View)

(1) Requirement
Reset lever on the high part of its cam. Clearance between the clutch release lever and the trip lever extension should be
Min 0.005 inch---Max 0.030 inch

(2) Requirement
With reset lever riding fully on its cam, there should be
Min some clearance between reset lever and function cam.

(3) Requirement
Reset lever should be axially positioned on shaft so that there is
Min some---Max 0.010 inch endplay allowed for the function clutch latchlever.

To Adjust
With clamp screw friction tight, position reset lever on its shaft.

(B) FUNCTION CLUTCH LATCHLEVER SPRING

Requirement
With function clutch turned to stop positions and latchlever unlatched
Min 12 oz---Max 15 oz
to start latchlever moving.

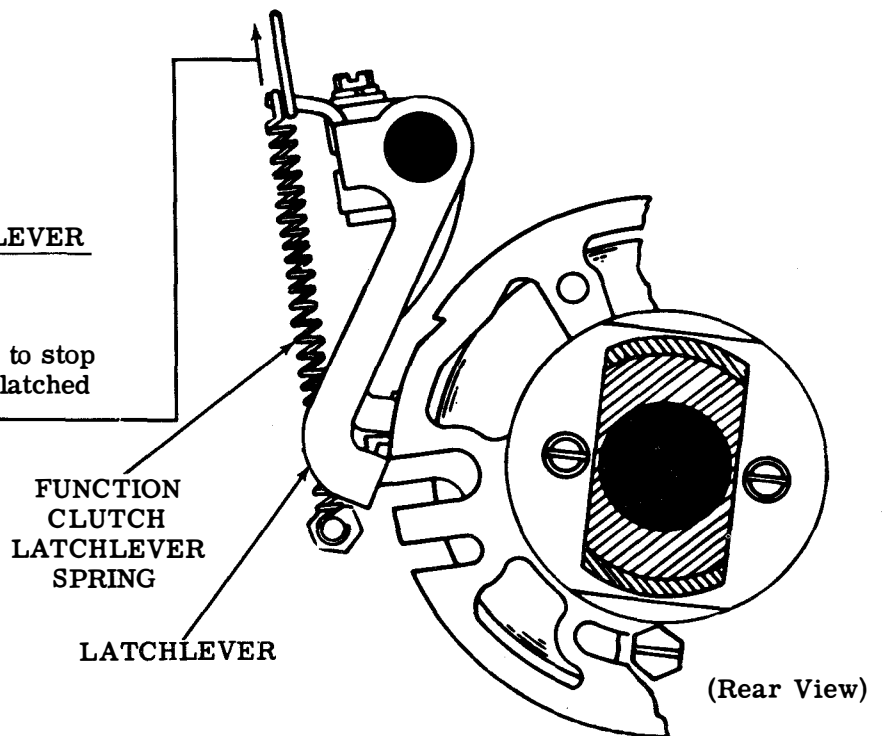

(Rear View)

SECTION 570-223-700

2.04 Function Mechanism (continued)

CLUTCH SHOE LEVER SPRING

To Check

Engage clutch. Hold cam disc to prevent it turning.

Requirement

For 8-level units
Min 15 oz---Max 20 oz

For 5-level units
Min 16 oz---Max 22 oz
to pull shoe lever in contact
with stop-lug.

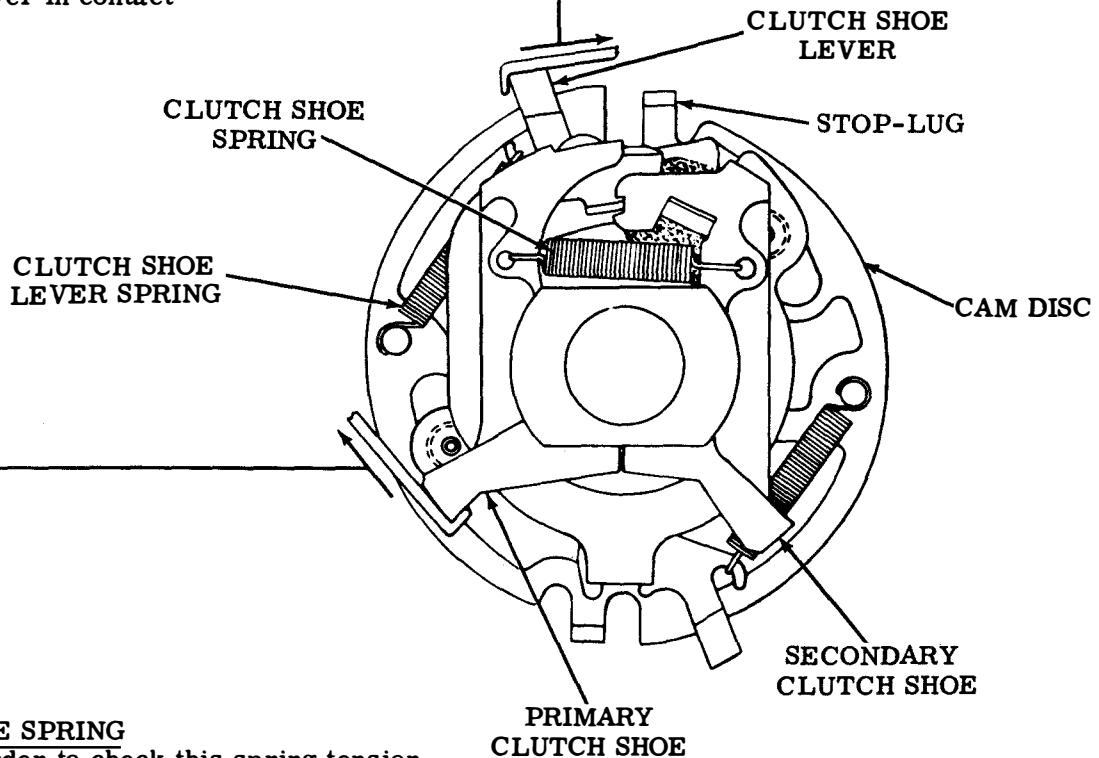

CLUTCH SHOE SPRING

Note: In order to check this spring tension, it is necessary to remove the clutch from the mainshaft. Therefore, it should not be checked unless there is reason to believe it will not meet its requirement.

To Check

Remove clutch from drum.

Requirement

Min 3 oz---Max 5 oz
to start primary shoe moving.

2.05 Function Mechanism (continued)

(A) FUNCTION CLUTCH RELEASE LEVER SPRING

Requirement

Trip function clutch. Rotate function shaft until release lever is reset on main trip lever.

Min 5 oz---Max 8 oz to start release moving.

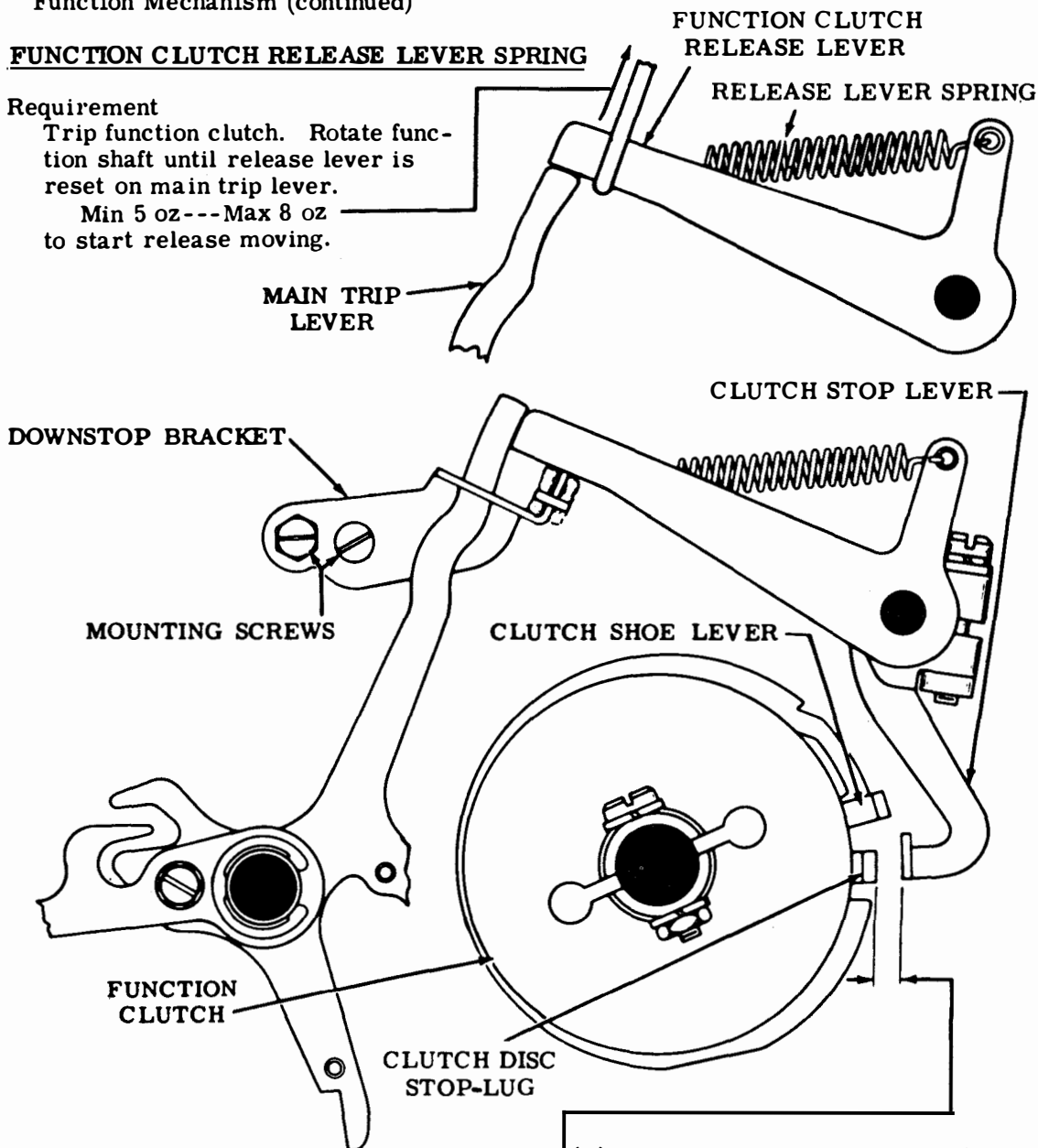

(Front View)

(B) RELEASE DOWNSTOP BRACKET

Requirement

With function clutch tripped, rotate shaft until clearance between function clutch disc stop-lug and clutch stop lever is at a minimum. Release resting against downstop bracket. Clearance between function clutch disc stop-lug and stop lever

Min 0.002 inch---Max 0.045 inch

To Adjust

With downstop bracket mounting screws friction, tighten position bracket. Tighten screws.

2.06 Function Clutch Trip Mechanism

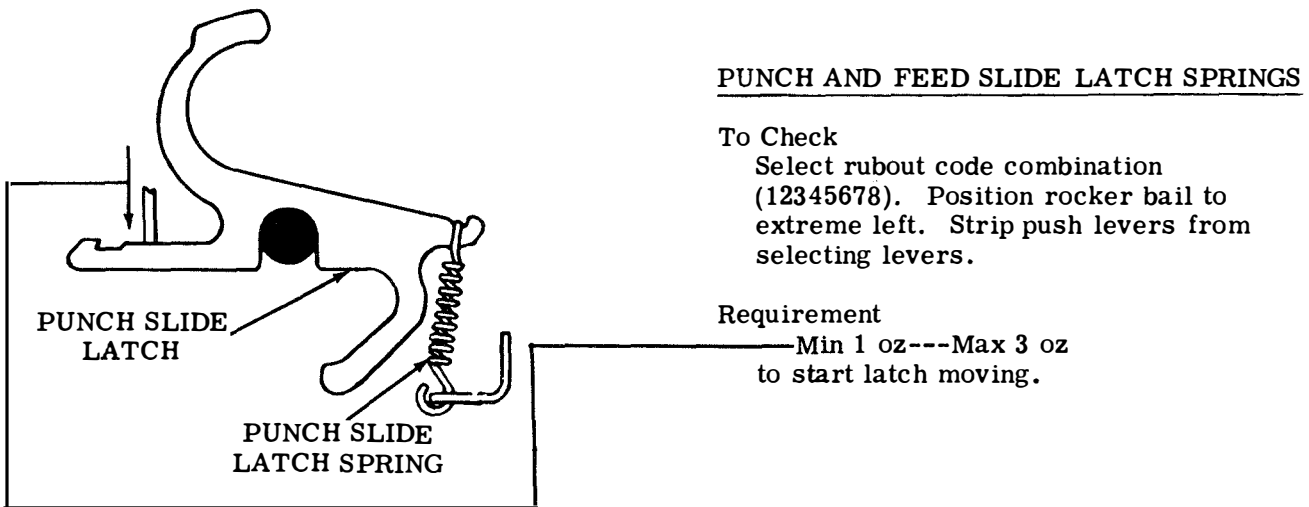
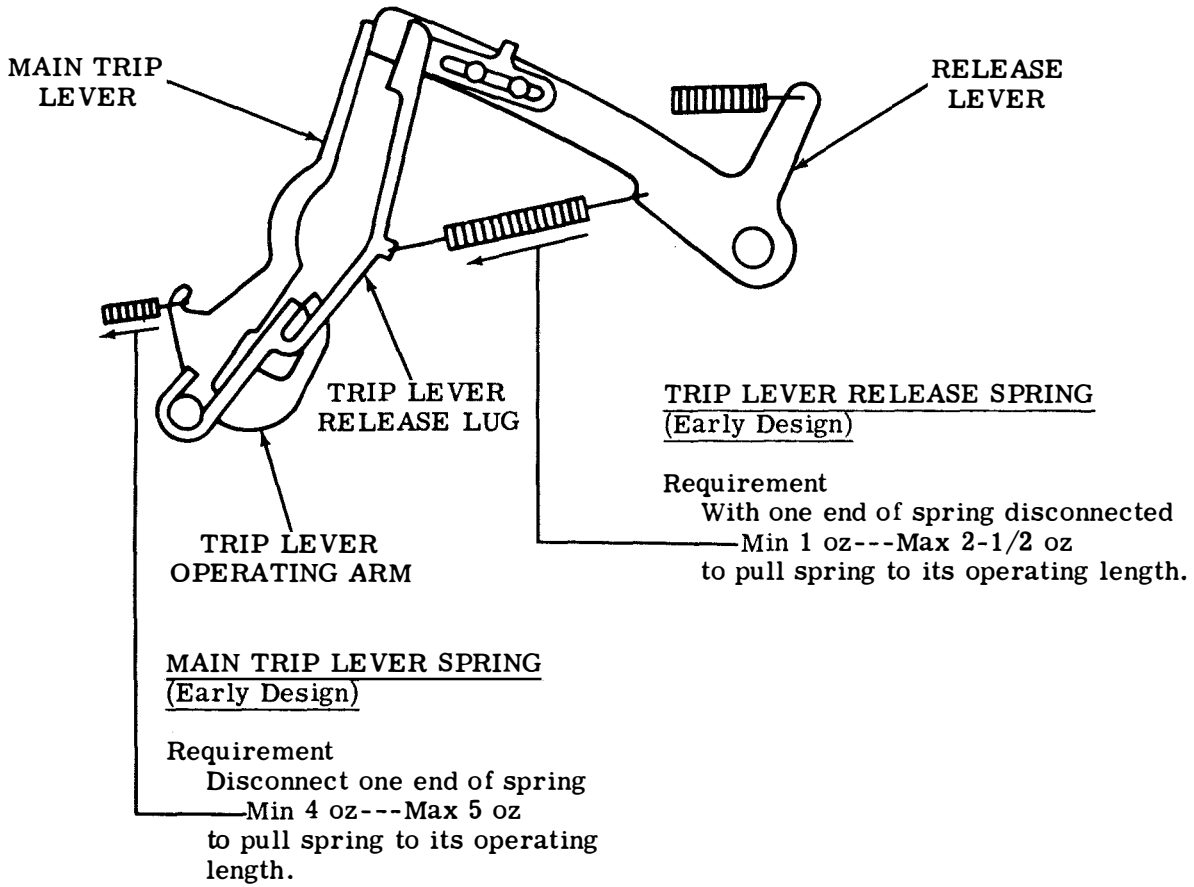

2.07 Function Mechanism (continued)

(A) CAM FOLLOWER ROLLER

Requirement

With rocker bail positioned to its extreme left and upper roller in contact with function cam

Min some---Max 0.004 inch clearance between cam and lower roller at point of least clearance.

To Adjust

Position lower roller mounting screw in elongated slot with locknut loosened. Tighten locknut.

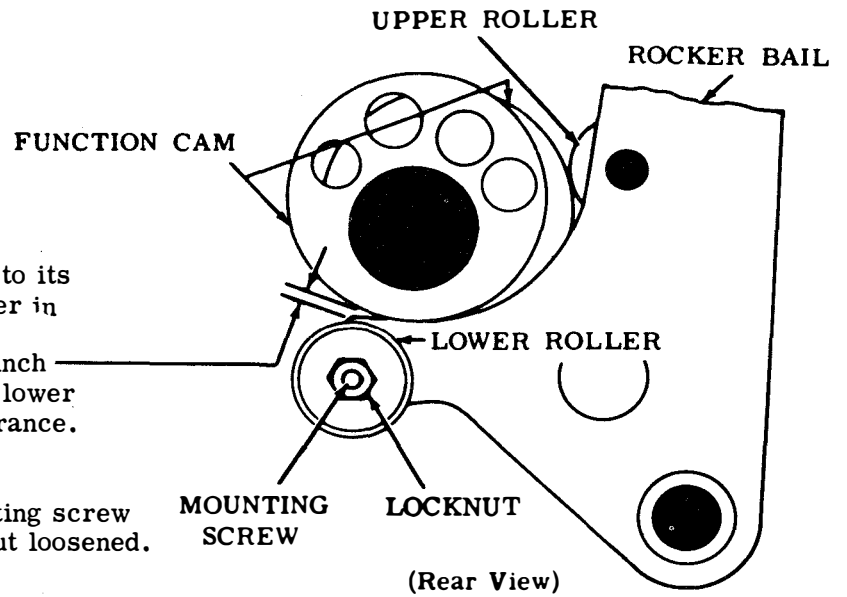

(B) CAM FOLLOWER ROLLER ALIGNMENT

(1) **Requirement**

Rocker bail rollers should engage full thickness of function cam.

(2) **Requirement**

Lifter roller in full engagement with rocker bail camming surface.

To Adjust

Position rocker bail and guide bracket with guide bracket mounting screws loosened. Tighten screws.

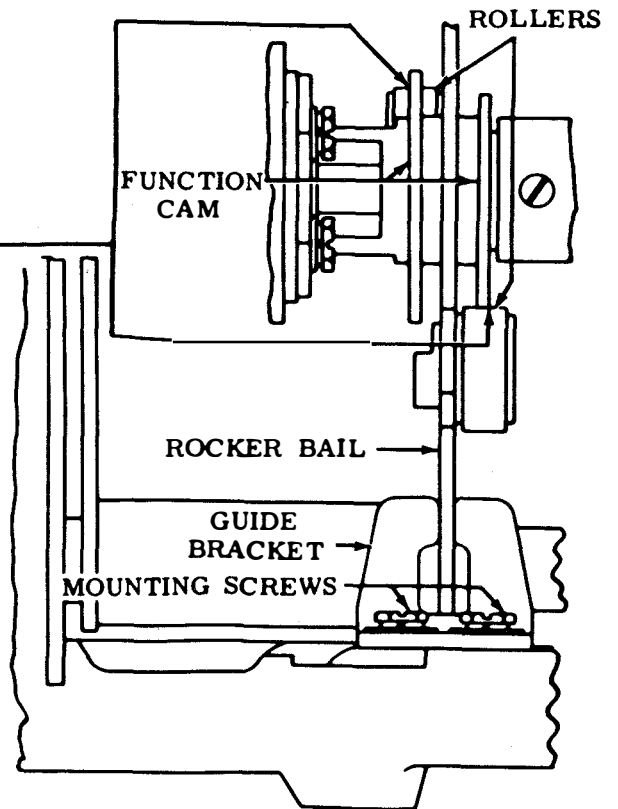

(Right Side View)

2.08 Punch Mechanism

Note: The adjustments on this page pertain to the keyboard tape punch.

PUNCH MOUNTING PLATE (Preliminary)

Requirement

The punch mechanism mounting screw beneath punch block and mounting screw at lower edge of punch mechanism backplate should be located centrally within their respective mounting holes.

Note: The mounting holes are oversize to facilitate use of punch mechanism on the typing reperforator.

To Adjust

Remove mounting screw at the lower edge of punch mechanism backplate, with the two remaining backplate mounting screws and mounting bracket screw friction tight, position punch mechanism so that the tapped hole of the frame is centrally located (as gauged by eye) within large body hole of punch mechanism backplate. Tighten the two backplate mounting screws and recheck to see that requirement is met. Replace and tighten the lower backplate mounting screw. Tighten the bracket mounting screw.

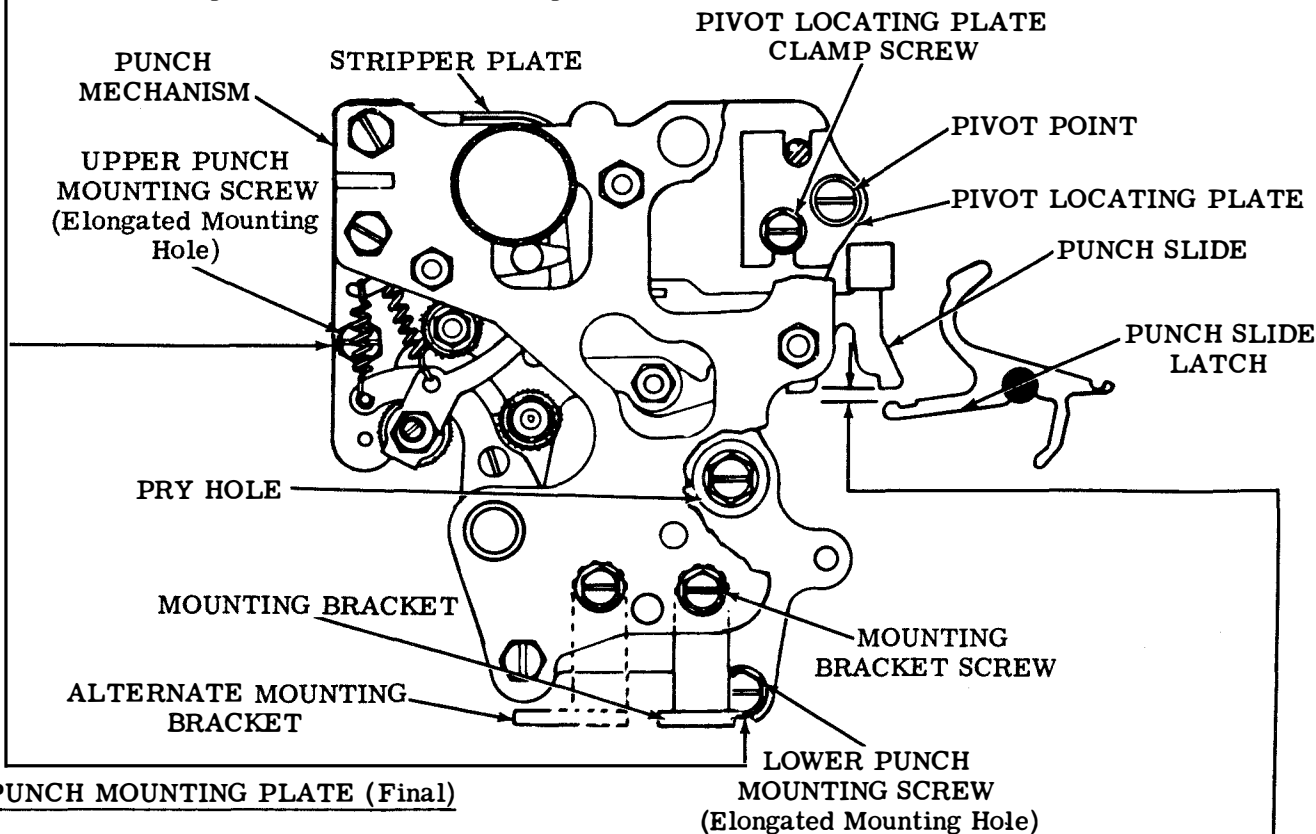

Requirement

With rubout code combination selected and the pushlevers in their extreme left hand position.

Min 0.015 inch---Max 0.045 inch clearance between the closest latchlever and associated punch slide.

To Adjust

With the rear frame mounting screws and front frame mounting bracket screws friction tight. Place tip of screwdriver between hexagon head screw and its clearance hole rim and pry up or down to meet requirements.

2.09 Punch Mechanism (continued)

Note: Before proceeding with the punch mechanism adjustments, check the CAM FOLLOWER ROLLER (2.07) adjustment and loosen the punch slide downstop mounting nut and guide mounting stud.

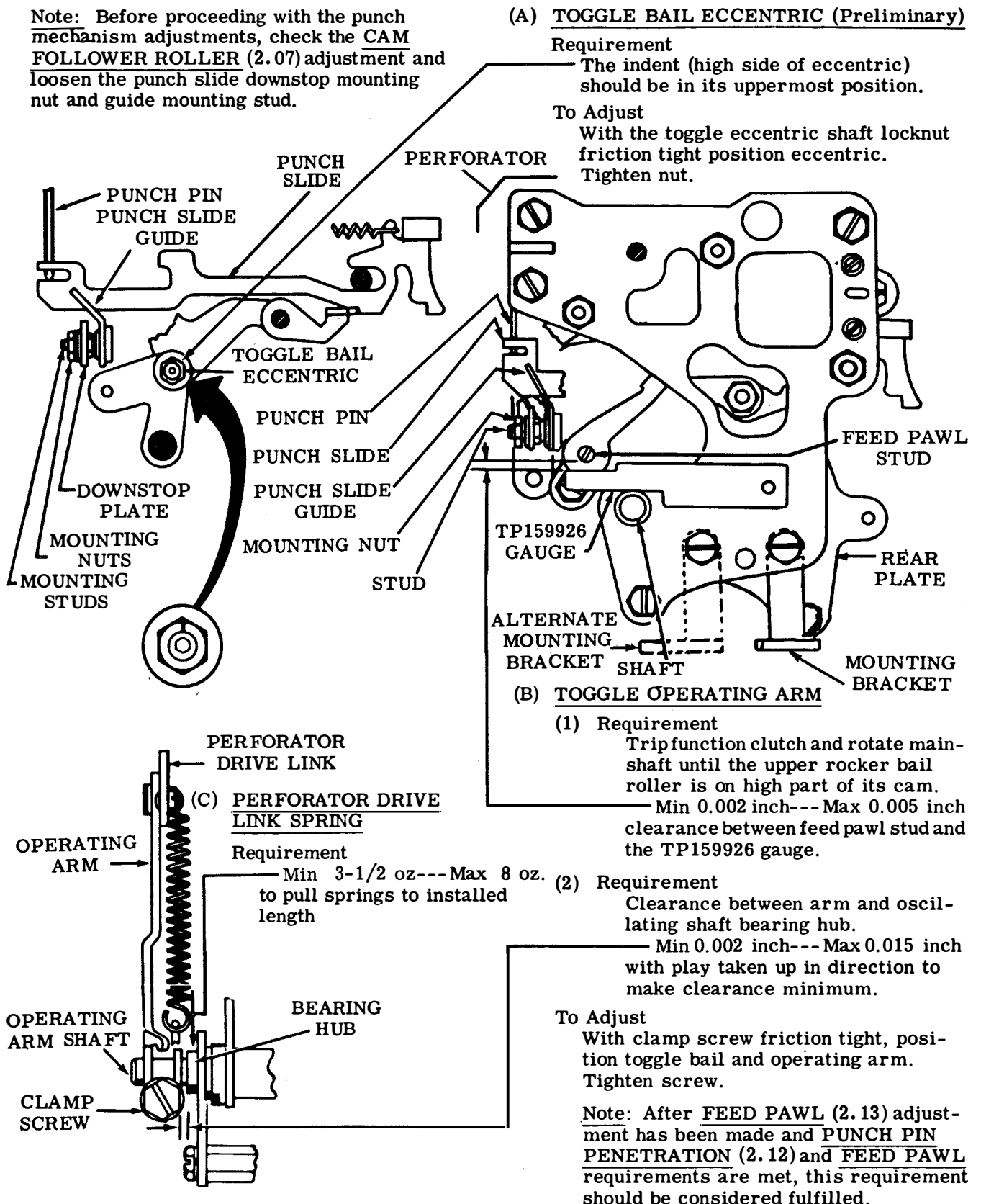

2.10 Punch Mechanism (continued)

PUNCH MOUNTING PLATE (Final) (Typing)

Note: The adjustments on this page pertain to the keyboard typing punch.

(1) To Check

Select rubout code combination (12345678). Rotate until function clutch trips with punch levers in extreme left-hand position.

Requirement

Clearance between punch slide and punch slide latch
 Min 0.015 inch---Max 0.045 inch
 at slide where clearance is least.

To Adjust

Loosen perforator mounting screws, adjusting clamp lockscrew, adjusting clamp pivot screw, and anchor bracket screw until friction tight. Place tip of screwdriver between screw and rim of pry hole and pry perforator up or down. Tighten only adjusting clamp lockscrew.

(2) To Check

Remove ribbon and tape. With unit in stop position and upper no. 7 pushbar to the right, check clearance between rear leg of stripper plate and type wheel. Select the R code combination (-2-5-78), trip the function clutch, and move rocker bail to its extreme left position. Check clearance between front leg of the stripper plate and type wheel.

Requirement

Clearance between the character P and the front or rear leg of stripper plate (whichever has the least clearance) should be
 Min 0.075 inch---Max 0.085 inch

To Adjust

Position perforator with two mounting screws, adjusting clamp pivot screw, and anchor bracket screw friction tight. Tighten screws. Check RESET BAIL TRIP LEVER (Final) (2.11) adjustment for some clearance and adjust if necessary.

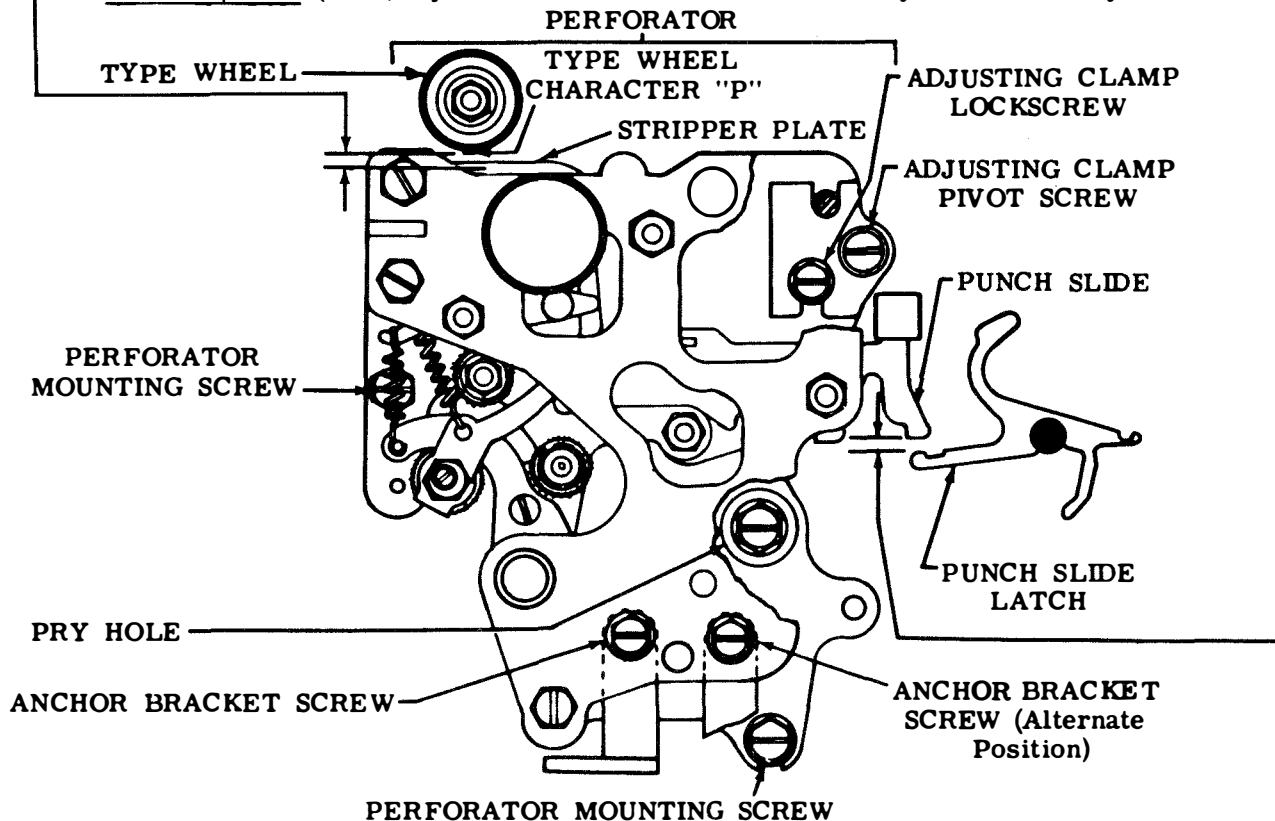

2.11 Punch Mechanism (continued)

RESET BAIL TRIP LEVER (Final)

(1) Requirement

Manually select the null code combination (all spacing). Manually rotate reset bail trip lever. The punch slide reset bail should trip before the function clutch is tripped.

To Adjust

With trip lever extension lock screw friction tight and delete (rubout) combination selected, position reset bail against punch slides. Take up play between reset bail and trip lever in a counterclockwise direction. Position trip lever by means of its pry point. Tighten screw.

(2) Requirement

With function clutch disengaged and latched, the punch slide reset bail should fully engage the punch slide latching surface when play in parts is taken up in direction to make the engagement the least.

To Adjust

Recheck requirement (1) above and refine adjustment if necessary

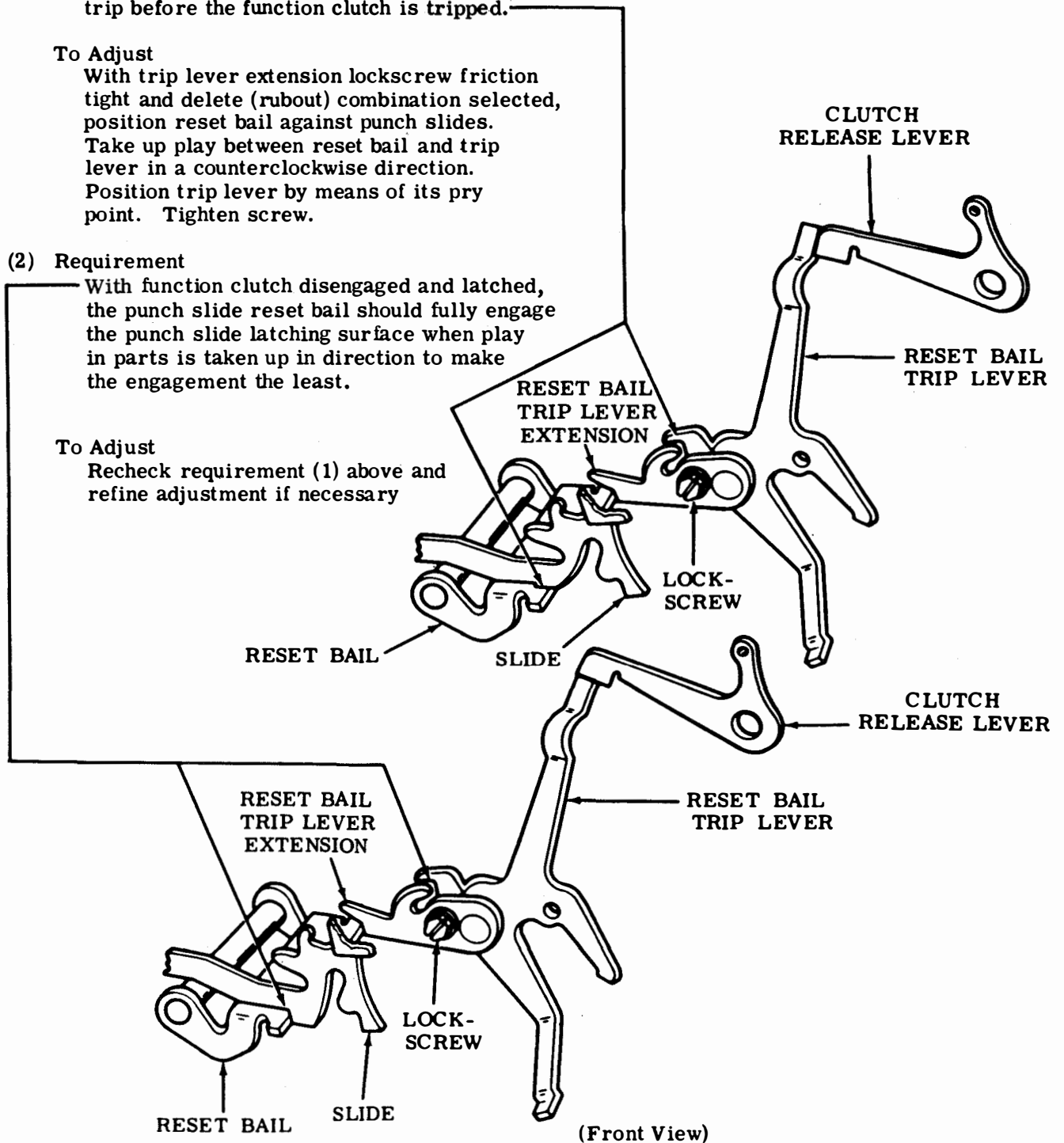

(Front View)

2.12 Punch Mechanism (continued)

(A) PUNCH PIN PENETRATION

(1) Requirement

With the RUBOUT combination selected, function clutch engaged, rotate mainshaft until all punch pins are into or above the tape aperture in punch block. With the TP159926 gauge in position

Min 0.050 inch
clearance between feed pawl stud and the gauge.

(2) Requirement

With RUBOUT combination selected, function clutch engaged, rotate mainshaft until all punch pins have cleared the punch block. With the TP159926 gauge in position

Min some---Max 0.080 inch
clearance between feed pawl stud and gauge.

To Adjust

Refine the TOGGLE BAIL ECCENTRIC (2.09) adjustment keeping the indent to the right of a vertical centerline through the shaft. Tighten nut.

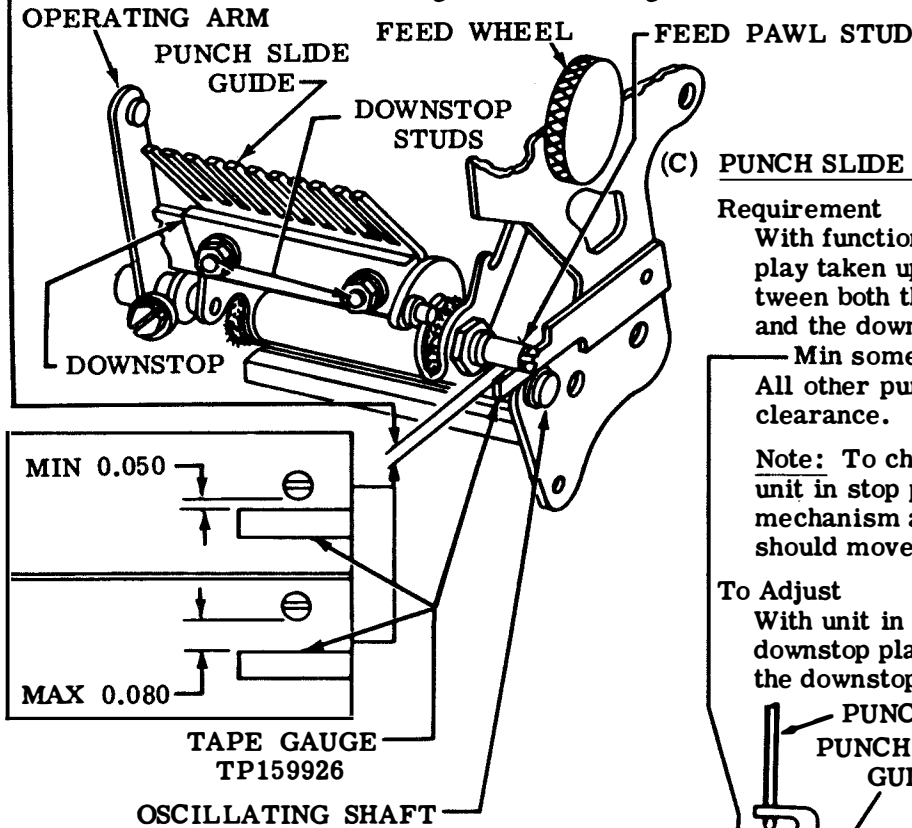

(C) PUNCH SLIDE DOWNSTOP POSITION

Requirement

With function clutch disengaged and latched, play taken up toward the top, clearance between both the front and rear punch slides and the downstop plate

Min some---Max 0.008 inch
All other punch slides should have some clearance.

Note: To check for some clearance, place unit in stop position, trip function trip mechanism and latches. The punch slides should move fully to their operated position.

To Adjust

With unit in stop position, loosen the two downstop plate mounting locknuts and locate the downstop plate to meet the requirement.

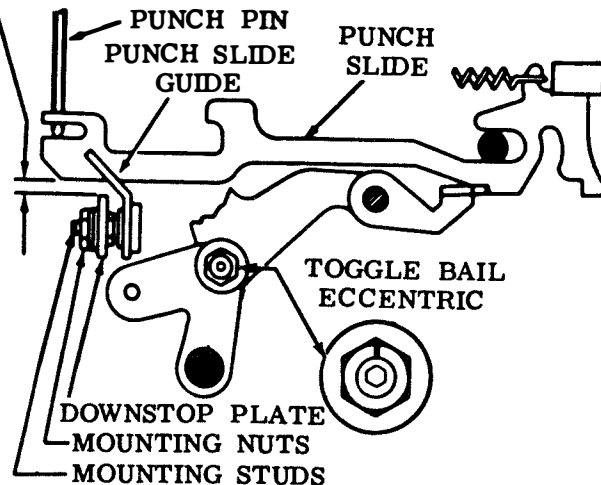

(B) PUNCH SLIDE GUIDE (Final)

Requirement

The punch slides should align with their corresponding punch pins and be free of binds after tightening the guide mounting studs. Each punch slide should return freely after being pushed in not more than 1/16 inch.

To Adjust

Position the guide with its mounting studs friction tight. Tighten studs.

2.13 Punch Mechanism (continued)

(A) LATCHLEVER CLEARANCE

Requirement

With NULL combination selected, the function clutch disengaged and latched, clearance between the punch slide and its associated latchlever should be

Min 0.008 inch---Max 0.020 inch
for the slide having the least clearance.

To Adjust

Rotate the reset bail eccentric shaft with its locknut loosened. Keep the indentation in the eccentric above center of shaft. Tighten locknut.

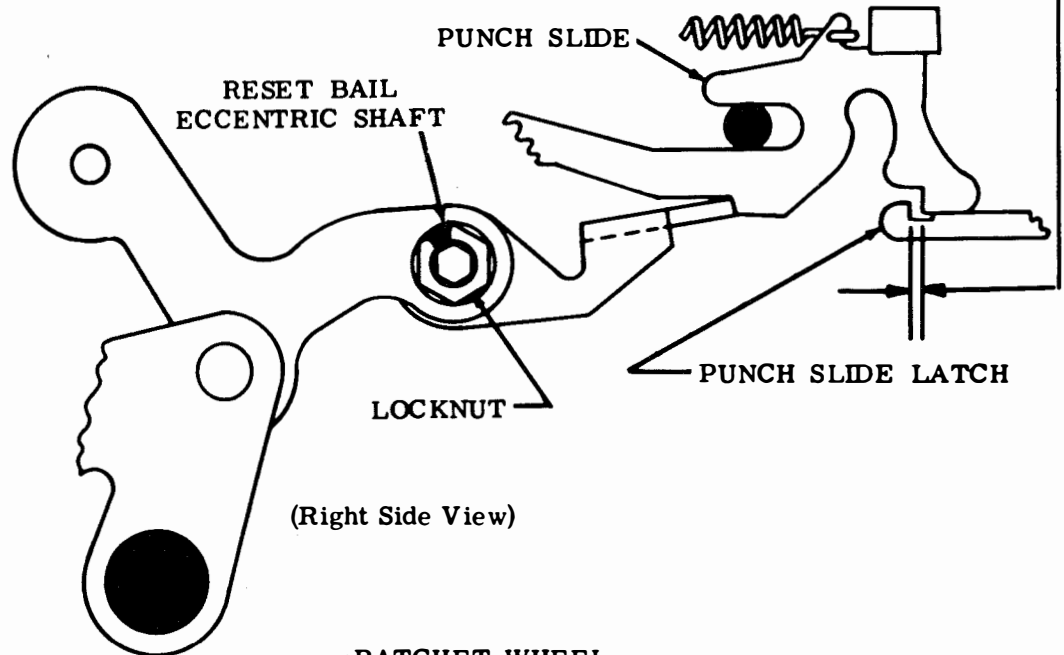

(Right Side View)

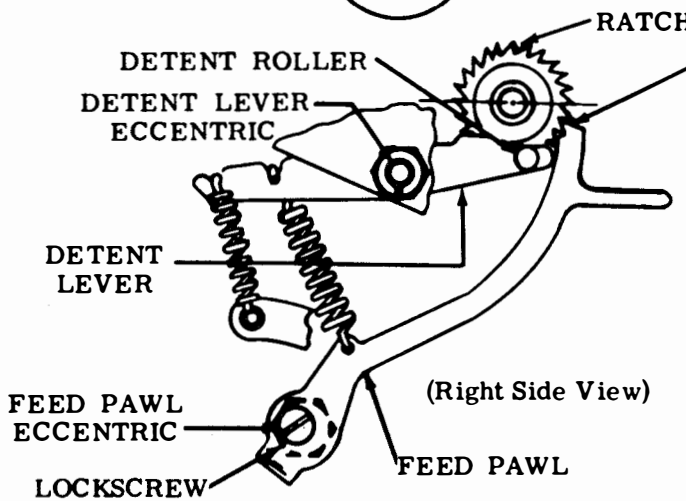

(Right Side View)

(B) FEED PAWL

To Check

Check with feed wheel oil hole in the up position.

Requirement

Function clutch disengaged, indentation in detent lever eccentric at right angle to lever, detent roller in contact with ratchet wheel, high part of feed pawl eccentric to the right of its lockscrew. The feed pawl should engage the first tooth below a horizontal centerline through the ratchet wheel with no perceptible clearance.

To Adjust

Rotate the feed pawl eccentric with lockscrew loosened. Tighten screw.

Note: This adjustment is related to TEN CHARACTERS PER INCH (2.15), and two adjustments should be made at same time.

2.14 Punch Mechanism (continued)

FEED PAWL SPRING

Requirement

Function clutch disengaged and latched.
Detent spring unhooked from toggle bail

Min 3 oz---Max 4-1/2 oz
to start the detent lever moving.

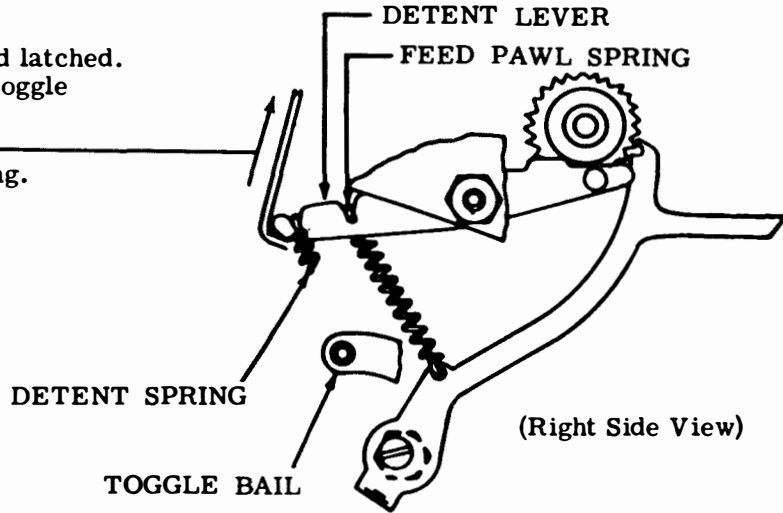

DETENT LEVER SPRING

Requirement

Function clutch disengaged and latched.
Feed pawl spring unhooked.

Min 7 oz---Max 10 oz
to start the detent lever moving.

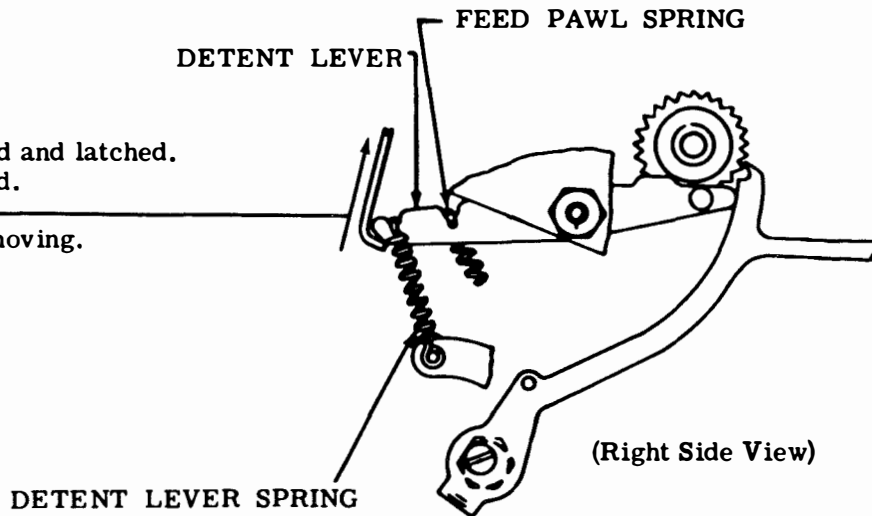

TAPE SHOE TORSION SPRING

Requirement

Min 13 oz---Max 18 oz
to move tape shoe from feed wheel.

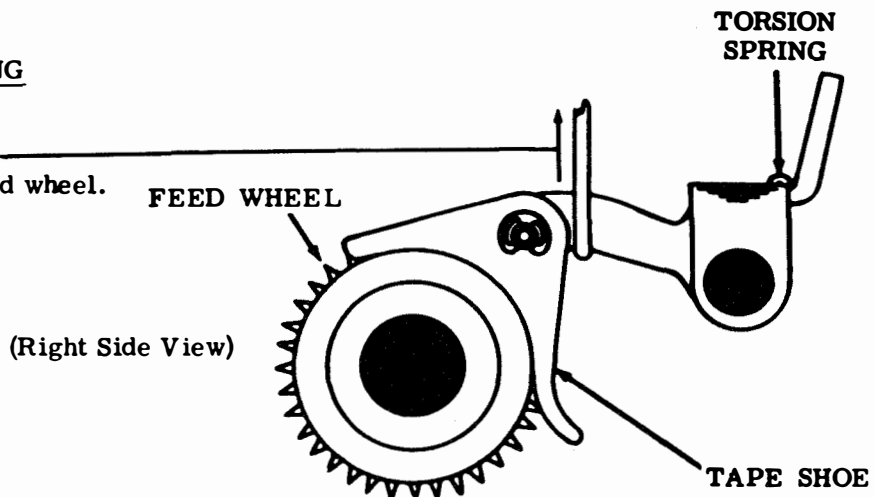

2.15 Punch Mechanism (continued)

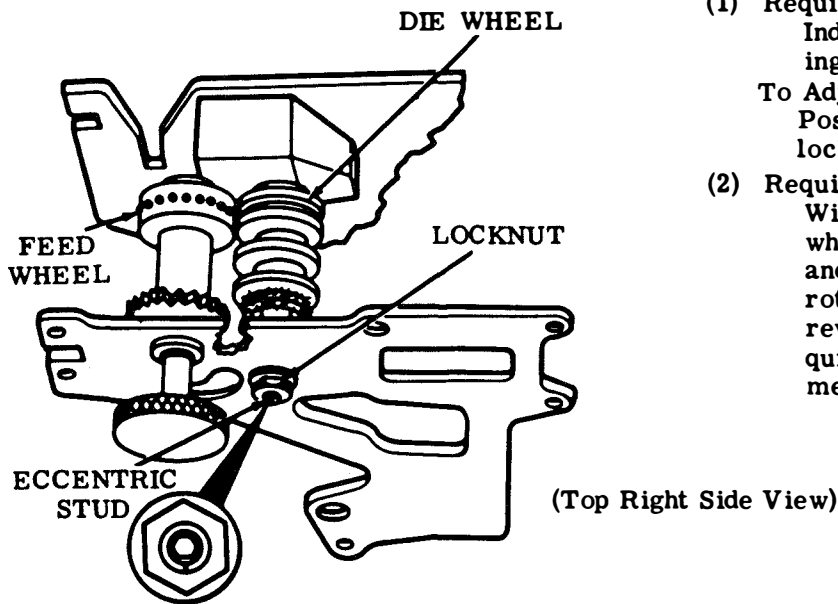
TEN CHARACTERS PER INCH (Preliminary)

- (1) Requirement
Indent of die wheel eccentric stud pointing downward.
- To Adjust
Position die wheel eccentric stud with locknut loosened. Tighten nut.
- (2) Requirement
With tape shoe blocked away from feed wheel, feed pawl and detent disengaged, and tape removed, feed wheel should rotate freely. Check through 3 or 4 revolutions of feed wheel. Refine requirement (1) above if necessary to meet this requirement.

Note: Before proceeding with the following adjustment check both BIAS SPRING (2.17) tensions, and if unit is equipped with a slack tape mechanism having a clamp plate with an adjustable wear disc, loosen the mounting nut and turn a new edge of the disc toward the tape. Tighten nut.

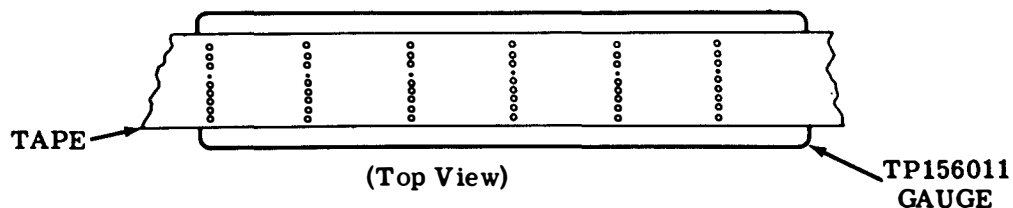
TEN CHARACTERS PER INCH (Final)

- (1) Requirement
With a piece of tape perforated with six series of 9 NULL code combinations followed by a DELETE combination placed over the smooth side of the TP156011 tape gauge so that the circular portion of the first number 2 code hole in the tape is concentric with the first hole of the tape gauge, the next four holes in the tape gauge should be visible through the number 2 code holes in the tape and the circular portion of the last (sixth) number 2 code hole in the tape should be entirely within the 0.086 diameter hole of the tape gauge.
- (2) Requirement
With tape shoe held away from feed wheel, feed pawl and detent disengaged and tape removed, feed wheel should rotate freely.

To Adjust

With tape removed from punch mechanism, loosen eccentric locknut and rotate die wheel eccentric shaft until it binds against feed wheel. Back off eccentric until die wheel is just free. Check through 3 or 4 rotations. Keep the indent of eccentric below the horizontal centerline of the stud. Refine adjustment for requirement (1), if necessary, by moving the die wheel toward the feed wheel to decrease the character spacing and away from the feed wheel to increase the character spacing. Tighten nut.

CAUTION: WITH TAPE REMOVED. MAKE SURE FEED WHEEL AND DIE WHEEL DO NOT BIND. RECHECK REQUIREMENT (1). IF NECESSARY, REFINE.

Note: First through fifth holes in gauge are same size as code holes in tape (0.072 inch diameter). Sixth hole in gauge is larger (0.086 inch). This arrangement allows ± 0.007 inch variation in 5 inches.

2.16 Punch Mechanism (continued)

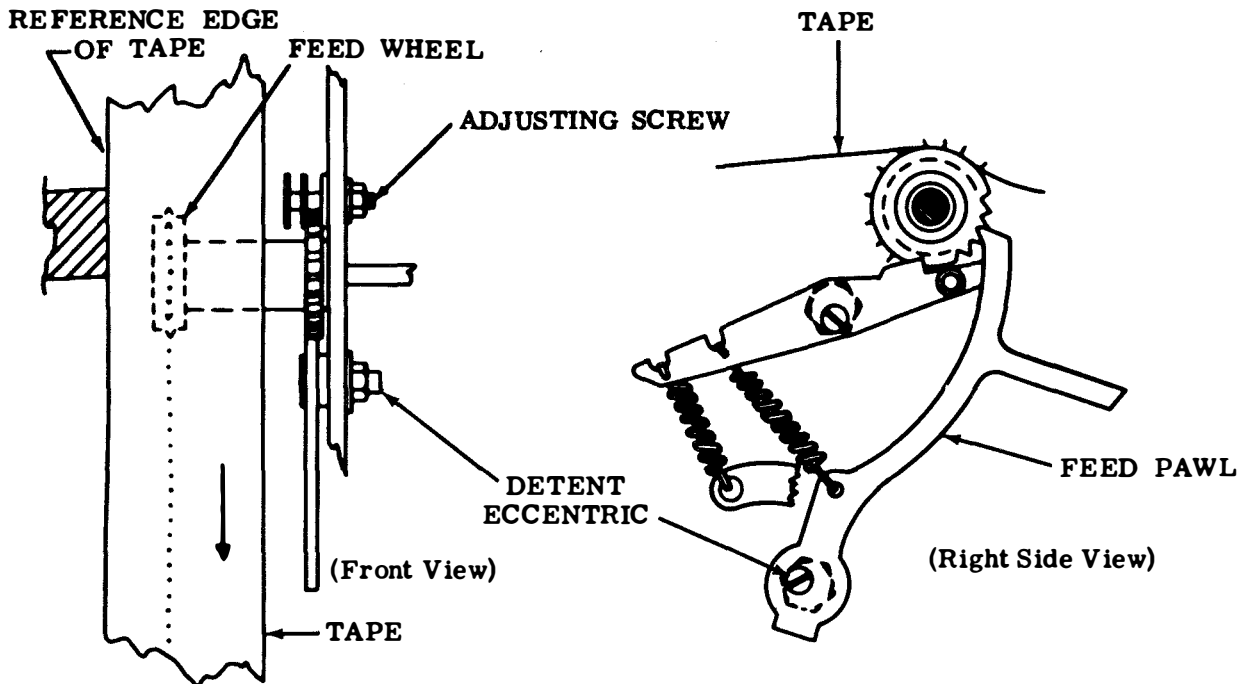

LATERAL AND FRONT TO REAR FEED WHEEL POSITION DETENT

Requirement

The indentations punched by the feed wheel should be centrally located between the punched feed holes (gauged by eye) and on same horizontal centerline. The unit must backspace the tape at least 30 characters without losing its point of registration.

To Check

Perforate 6 inches of RY tape. Backspace 30 characters. Reperforate with DELETE characters. Code holes must coincide except for first two characters which may be elongated ± 0.010 inch.

To Adjust (Laterally)

Rotate detent eccentric clockwise to move the feed wheel perforation toward the leading edge of the feed hole and rotate eccentric counterclockwise to move the perforation toward the trailing edge of the feed hole. Tighten locknut. Refine FEED PAWL (2.14) adjustment if necessary.

To Adjust (Front to Rear)

Loosen locknut on adjusting screw and rotate the screw counterclockwise to move the indentations in the tape away from the reference edge (rear) of the tape. To move indentations in the tape toward the reference edge of the tape, rotate adjusting screw clockwise. Tighten nut. Refine the lateral adjustment above if necessary.

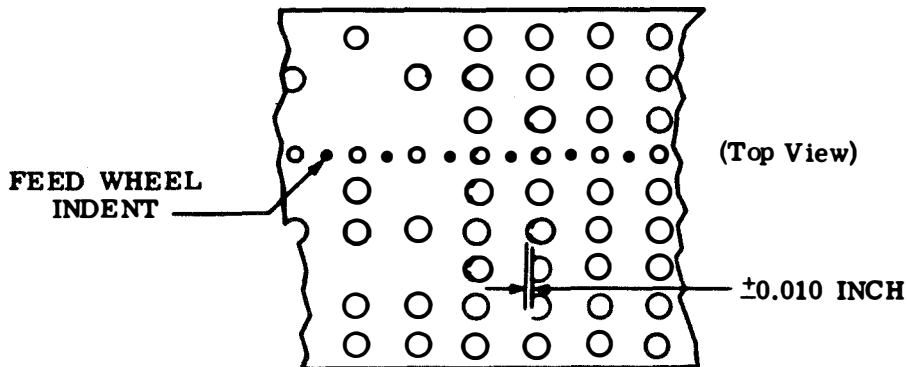

2.17 Punch Mechanism (continued)

PUNCH SLIDE SPRING

Requirement

DELETE combination set up, and punch slides in selected position

Min 2-1/4 oz---Max 3-1/4 oz to start each slide moving.

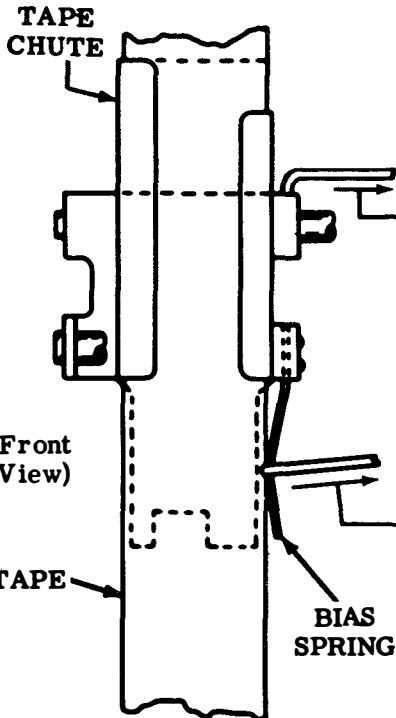
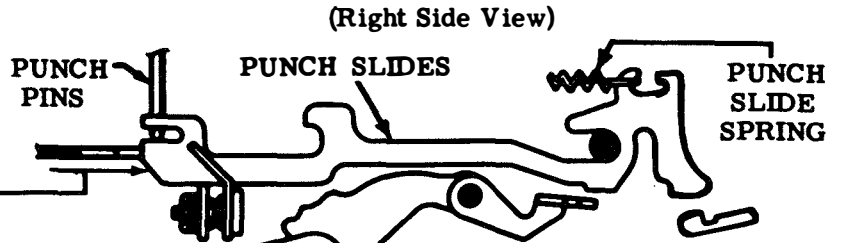

TAPE GUIDE ASSEMBLY SPRING

(1) Requirement

Min 16 oz to pull tape guide assembly away from tape guide block.

(2) Requirement

Tape guide assembly should move freely on shaft.

To Adjust

With mounting screws loosened, position mounting post. Tighten screws.

BIAS SPRING (TAPE CHUTE)

Requirement

With function clutch disengaged and latched, tape threaded through punch mechanism, it should require

Min 1-1/4 oz---Max 2-1/4 oz

to just move the spring away from the tape

To Adjust

Bend the spring.

Note: It is necessary to remove several parts, on units equipped with backspace mechanism, in order to check this spring tension. It should not be checked unless there is good reason to believe that requirements are not met.

BIAS SPRING (PUNCH BLOCK)

(1) Requirement

With tape removed from the punch block, the tape guide spring should rest against the clearance slot in the block in a symmetrical manner.

(2) Requirement

With tape in the punch block and the reperforator operating under power, the spring should not distort the edge of the tape.

To Adjust

Bend the spring and position it with its mounting screw loosened. Tighten screw.

PUNCH BLOCK

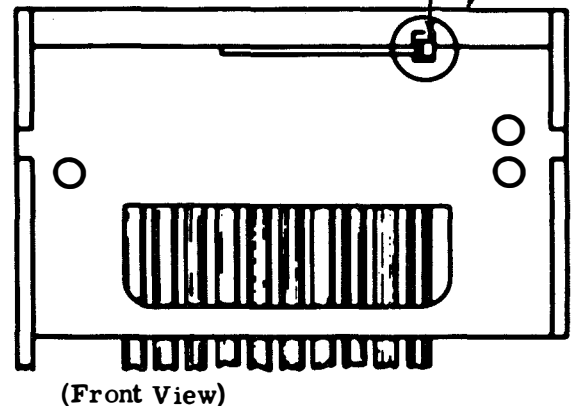
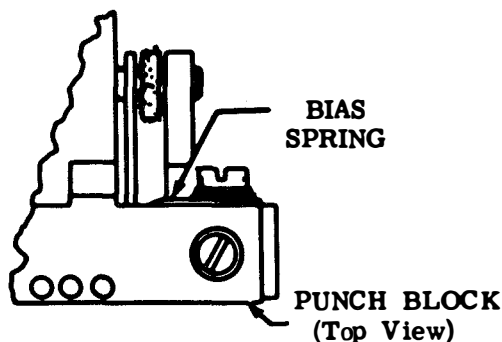

2.18 Power Drive Backspace Mechanism

(A) BACKSPACE RATCHET

Requirement

Teeth of backspace and feed wheel ratchets to line up (visual alignment). Feed wheel ratchet to be in detented position.

To Adjust

With adjusting clamp mounting screw friction tight, rotate backspace ratchet to meet the requirement. Tighten screw.

(B) BACKSPACE PAWL CLEARANCE

(1) Requirement (Preliminary)

With backspace bellcrank rotated clockwise, the backspace pawl should miss the first tooth by a clearance of
Min 0.003 inch---Max 0.010 inch
at point of least clearance.

(2) Requirement (Final)

The backspace pawl should miss the first tooth and engage the second tooth by at least 1/2 of the right engaging surface of the backspace pawl (as gauged by eye) when backspace pawl first contacts the ratchet tooth.

To Adjust

Take up all rotational play of backspace ratchet in relation to feed ratchet by rotating it clockwise at same time rotate bellcrank clockwise. With mounting screw friction tight, rotate eccentric post to meet the requirements. Tighten screw.

Final minimum engagement:
1/2 of surface with second ratchet tooth at first point of contact.

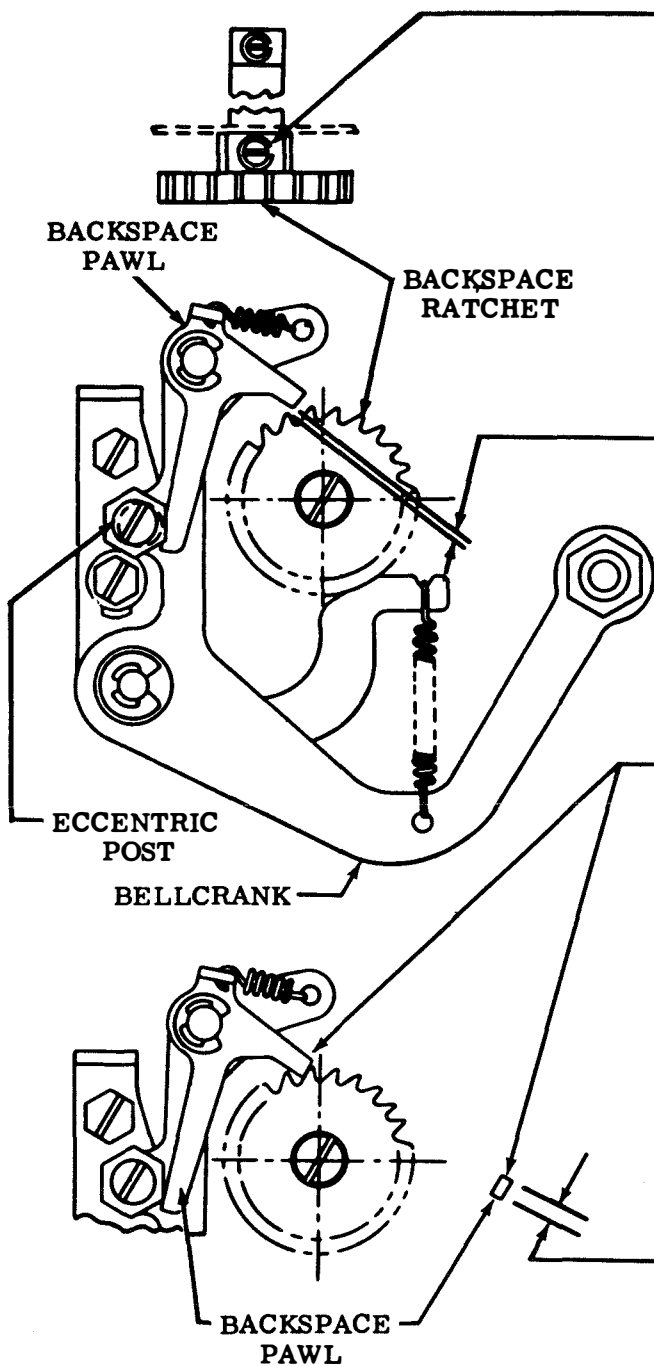

2.19 Power Drive Backspace Mechanism (continued)

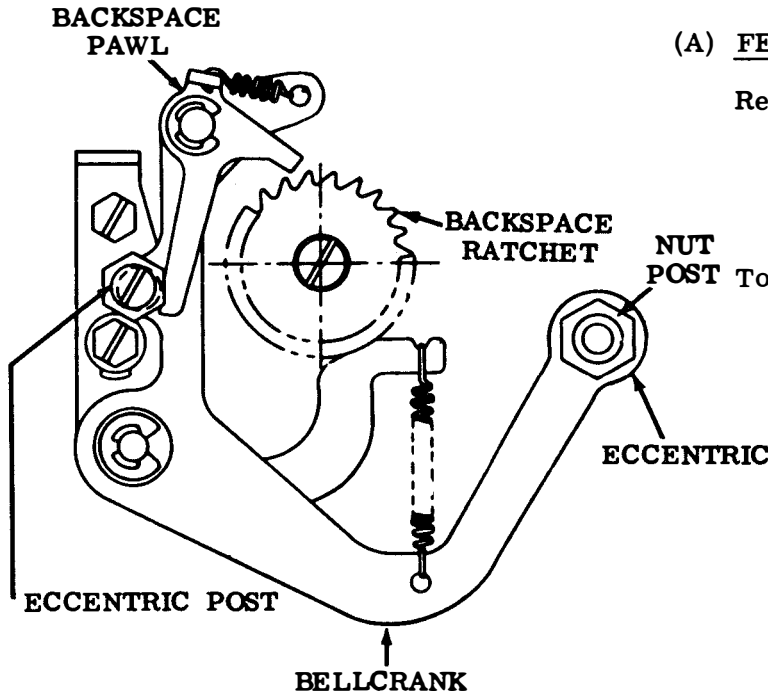

(A) FEED PAWL ECCENTRIC (Preliminary)

Requirement

With the backspace bellcrank assembly in its operated position, the high side of the eccentric should be in its uppermost position.

To Adjust

Loosen the nut post (friction tight) and rotate the eccentric with an allen wrench. Tighten the nut post.

(B) ARMATURE HINGE (Early Design)

Requirement

With armature bail spring removed, armature held against the pole face, take up play at hinge in a downward direction. Clearance between the armature and magnet bracket.

Min some---Max 0.004 inch

To Adjust

With hinge mounting screws friction tight, position hinge. Armature should touch front and rear of pole face. Tighten screws and recheck adjustment.

Note: For dc operation, the armature should be positioned so that the side marked "C" faces pole face of magnet core. For ac operation, unmarked side faces pole.

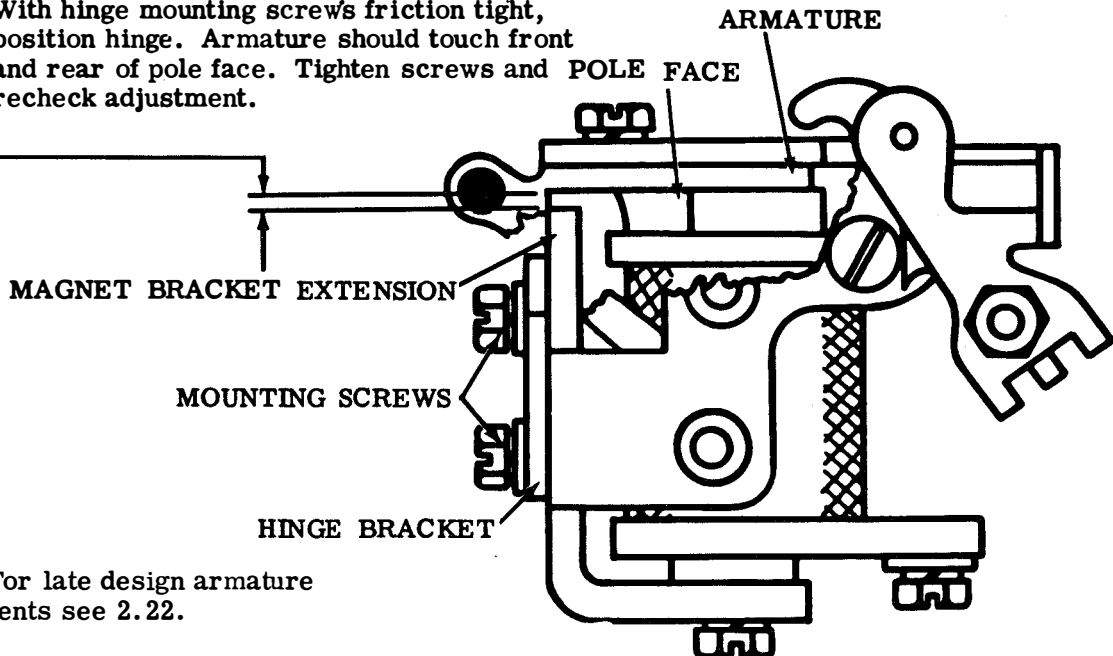

Note: For late design armature adjustments see 2.22.

2.20 Power Drive Backspace Mechanism (continued)

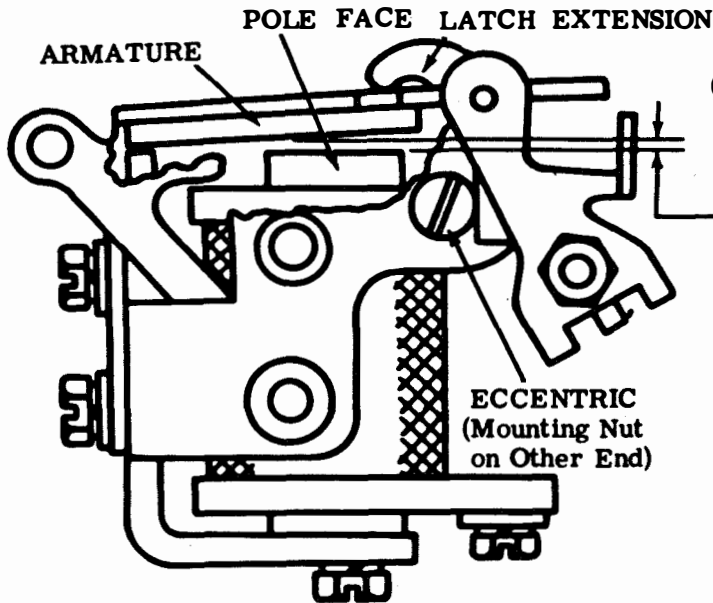

(A) ARMATURE UPSTOP (Early Design)

Requirement

Armature in unoperated position.
Gap between armature and pole face
— Min 0.025 inch---Max 0.030 inch
at closest point.

To Adjust

Rotate eccentric with mounting nut
loosened. Keep high part of eccentric
to left. Tighten nut.

(B) DRIVE LINK (Early Design)

Requirement

With high part of eccentric arm in left-hand position, armature against pole face to allow drive arm latchlever to rest against eccentric link

Min 0.040 inch---Max 0.045 inch
clearance between step on eccentric arm and latchlever with play taken up to make gap a maximum.

To Adjust

With drive arm screw friction tight, position adjusting link. Tighten screw.

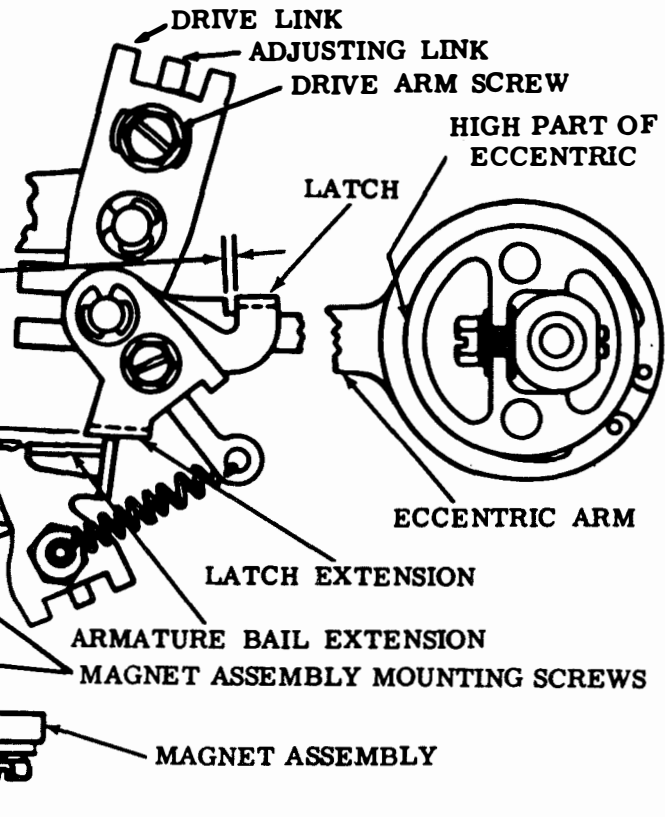

(C) LATCH EXTENSION (Early Design)

Requirement

With backspace mechanism in unoperated position, eccentric high part at the left, armature against the pole face, latch resting on the eccentric arm notch, clearance between top of armature extension and latch extension

— Min 0.005 inch---Max 0.020 inch

To Adjust

With magnet mounting screws friction tight, swing magnet left or right. Tighten screws.

2.21 Power Drive Backspace Mechanism (continued)

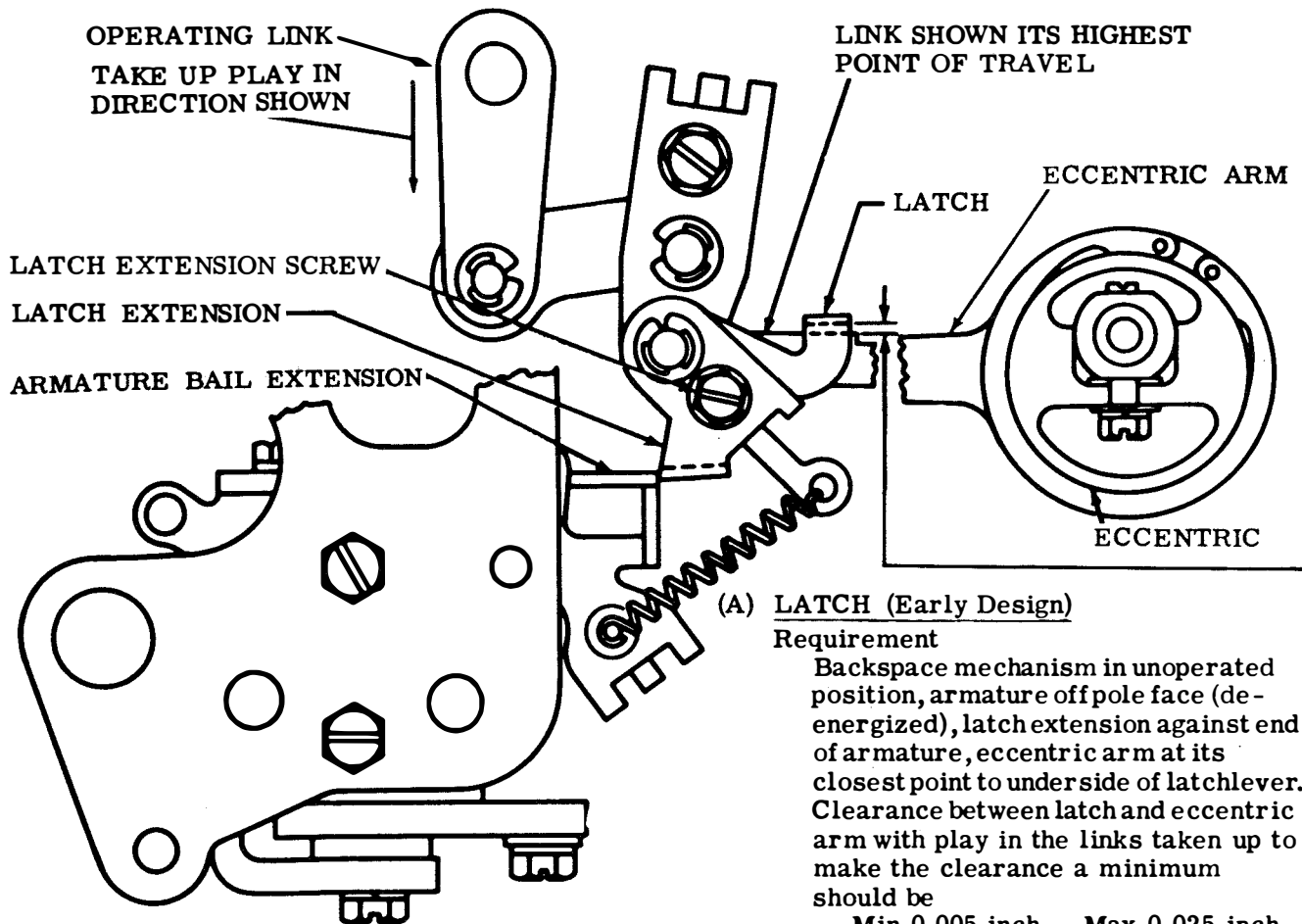

(A) LATCH (Early Design)

Requirement

Backspace mechanism in unoperated position, armature off pole face (de-energized), latch extension against end of armature, eccentric arm at its closest point to underside of latchlever. Clearance between latch and eccentric arm with play in the links taken up to make the clearance a minimum should be

Min 0.005 inch---Max 0.025 inch

To Adjust

With latch extension screw friction tight, position latch. Tighten screw.

(B) NONREPEAT ARM (Early Design)

Requirement

Backspace mechanism in unoperated position. Clearance between top surface of nonrepeat arm and lowest point of latch extension

Min 0.002 inch---Max 0.010 inch

To Adjust

With arm screw friction tight, position adjusting arm. Tighten arm screw.

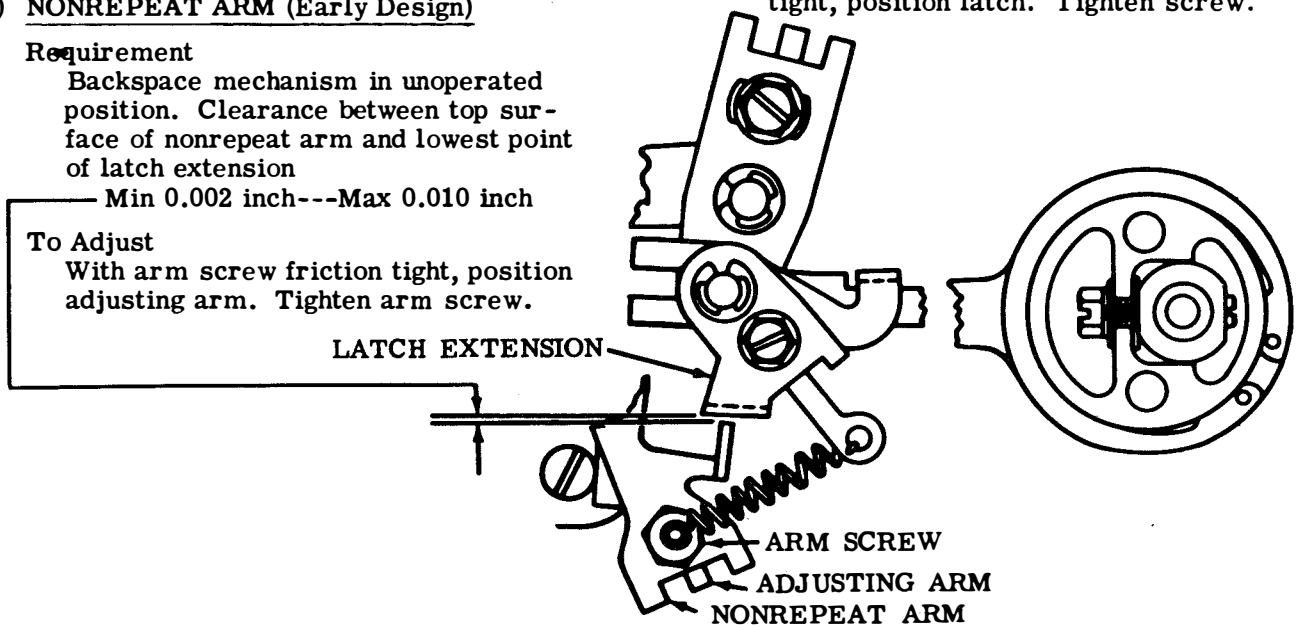

2.22 Power Drive Backspace Mechanism (continued)
(Nonadjustable Backspace Magnet Assembly)

Note 1: For early design adjustable magnet assembly see 2.19.

(A) ARMATURE SPRING (Late Design)

Requirement

Min 15 oz---Max 20 oz
to pull spring to installed
length.

(B) LATCH EXTENSION SPRING (Late Design)

Requirement

Min 1 oz---Max 2-1/4 oz
to start latch moving.

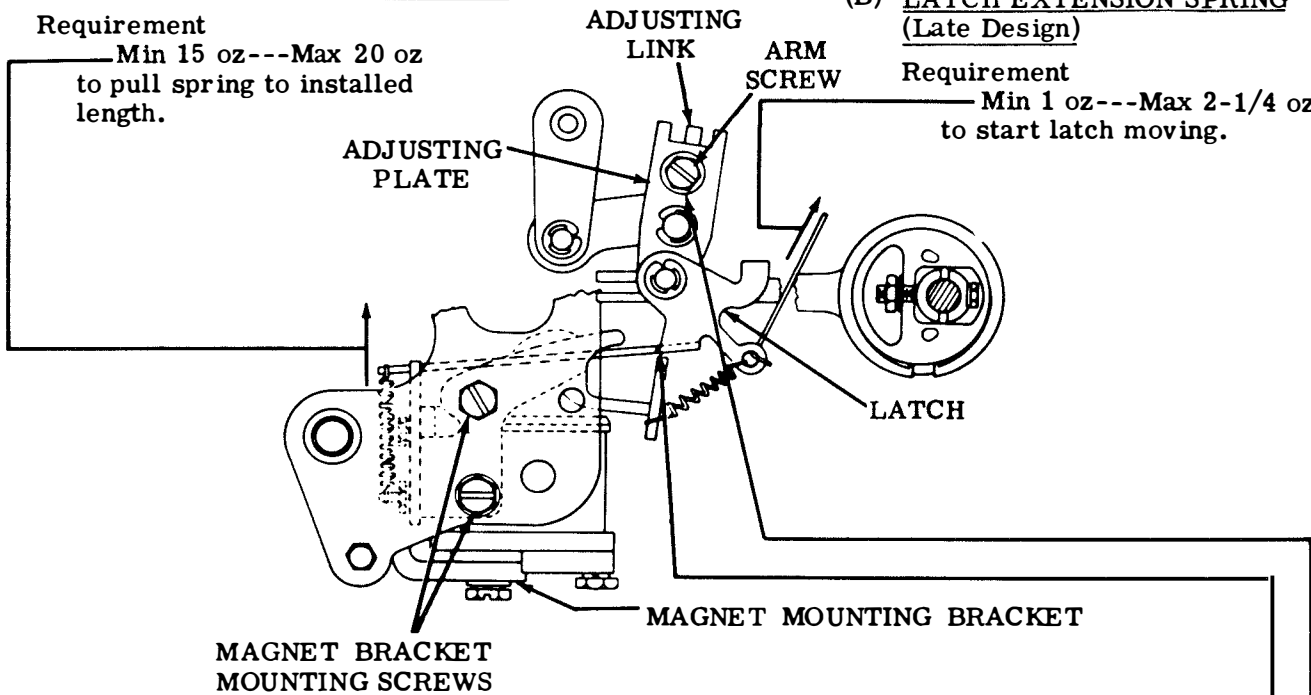

MAGNET BRACKET
MOUNTING SCREWS

(C) MAGNETIC POSITION (Late Design)

Requirement

The armature extension should engage the latch by approximately its full thickness when the magnet is de-energized.

To Adjust

Position the magnet assembly by means of its mounting screws. Tighten screws.

Note 2: The final adjustment requirement for all backspace mechanisms, manual or power drive, regardless of the type of unit will read as follows:

(D) FINAL POWER ADJUSTMENT (Late Design)

(1) Requirement

With tape in the unit, place the feed wheel shaft oil hole in its uppermost position, operate the backspace mechanism once. The ratchet wheel should be backed one space into a fully detented position.

Note 3: A fully detented position is defined as: With the detent roller in contact with the ratchet wheel the punch unit feed pawl should engage the first tooth below the horizontal centerline of the feed wheel ratchet with no perceptible clearance.

(2) Requirement

With the unit operating under power, perforate approximately two inches of tape with the RUBOUT combination selected. Backspace twelve characters in succession with the unit still under power. Again perforate approximately two inches of tape with the RUBOUT combination selected. Clipping of the code holes should be held to a minimum and should not exceed more than 0.005 inch, as gauged by eye.

To Adjust

Loosen the arm adjusting screw and position the adjusting plate. Tighten the arm adjusting screw.

2.23 Power Drive Backspace Mechanism (continued)

(A) FEED PAWL SPRING

Requirement

Backspace mechanism in unoperated position.

Min 4 oz---Max 6 oz
to start feed pawl moving.

(B) BELLCRANK SPRING

Requirement

Min 9 oz---Max 12 oz
to pull spring to installed length.

(C) ARMATURE LATCH SPRING
(Early Design)

Requirement

Min 1 oz---Max 2-1/4 oz
to pull armature latch spring
to installed length.

Note: All spring tensions should be taken with the mechanism in unoperated position.

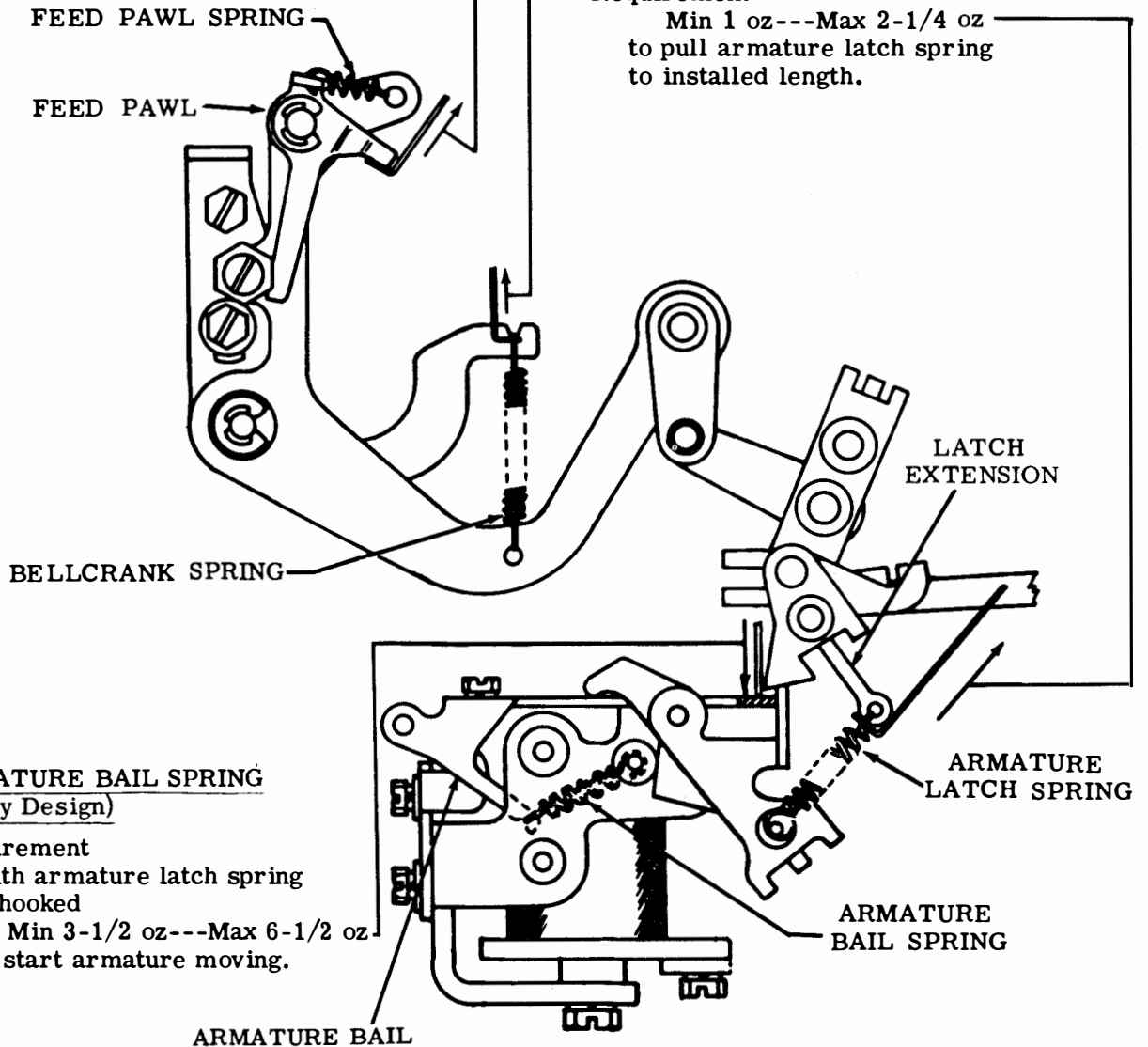

(D) ARMATURE BAIL SPRING
(Early Design)

Requirement

With armature latch spring unhooked

Min 3-1/2 oz---Max 6-1/2 oz
to start armature moving.

2.24 Keyboard Mechanism

(B) CODE LEVER UNIVERSAL BAIL SPRING

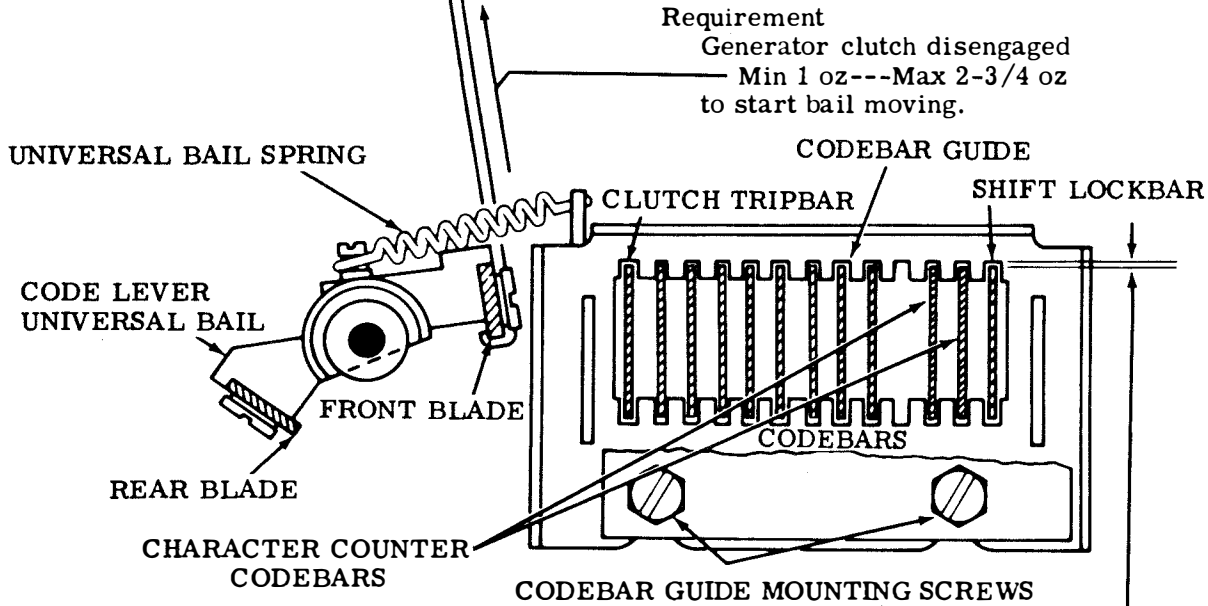

(A) CODEBAR GUIDE CLEARANCE

Requirement
Min some clearance---Max 0.006 inch
All codebars should move freely without bind.

To Adjust
Loosen mounting screws and position codebar guide.

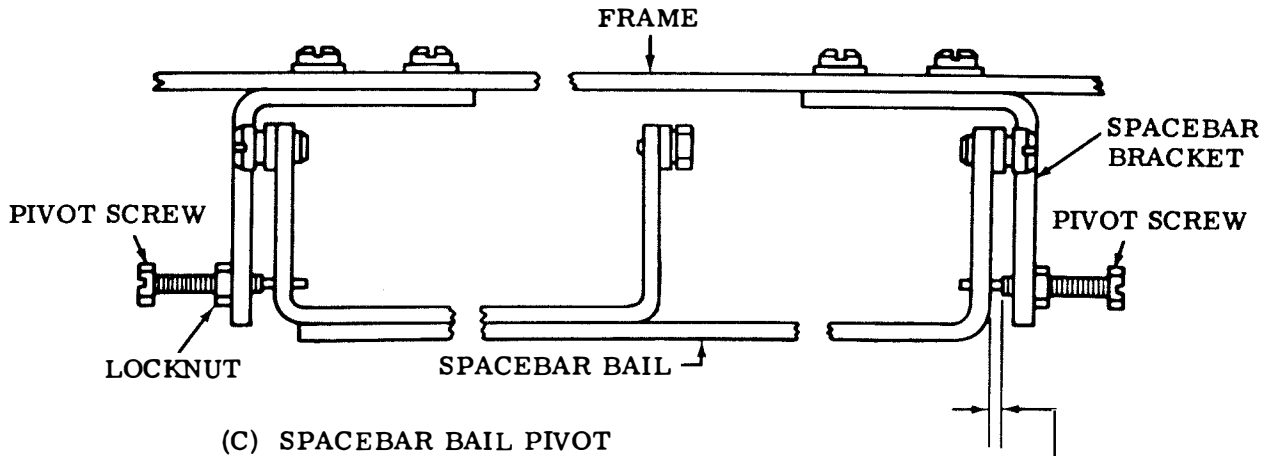

Requirement
Min some endplay---Max 0.010 inch
Spacebar free from bind.

To Adjust
Position spacebar with pivot screws.

2.25 Keyboard Mechanism (continued)

(B) CLUTCH TRIPBAR SPRING (Nonparity)

Requirement

Clutch disengaged. Power off
 Min 8 oz---Max 12 oz
 to move bar.

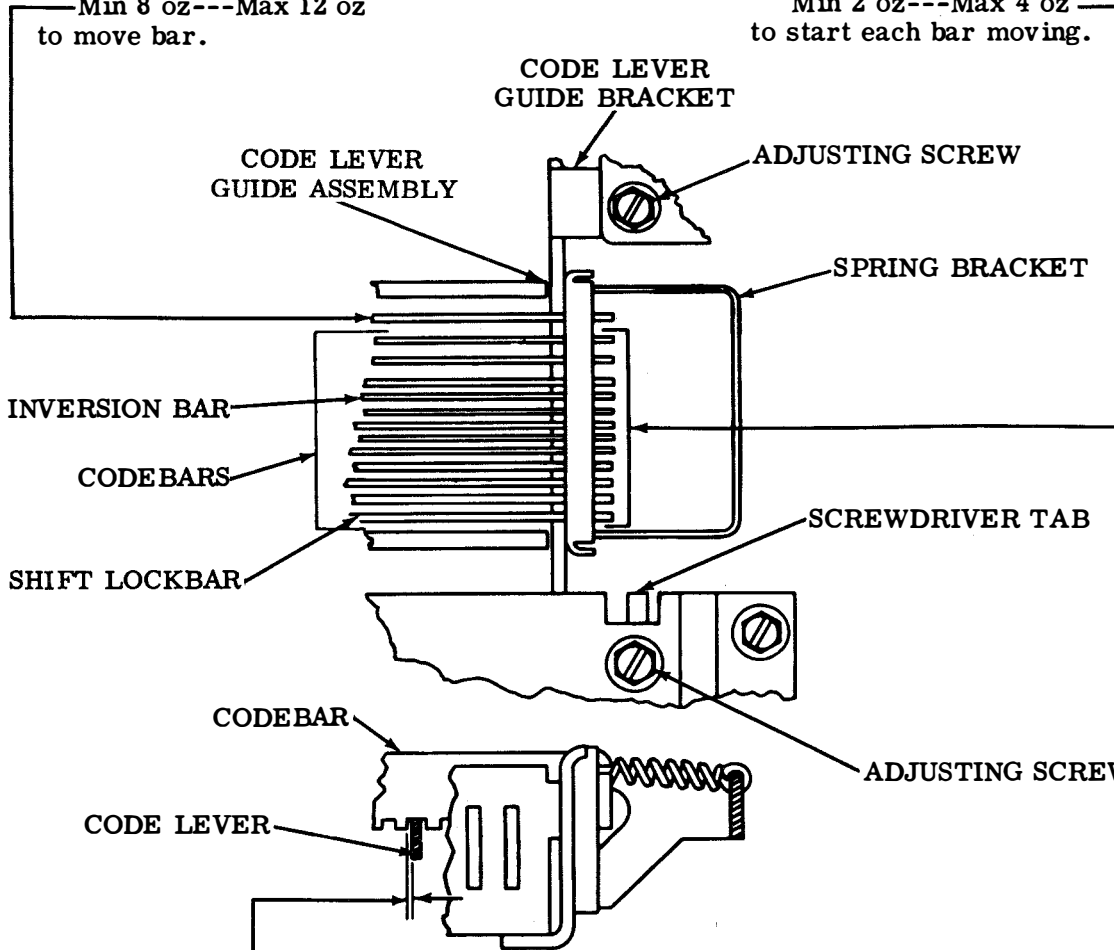

(C) CODEBARS, SHIFT LOCKBAR, AND INVERSION BAR SPRING (Nonparity)

Requirement

Depress rubout or letter key. Power off. Transfer levers held right
 Min 2 oz---Max 4 oz
 to start each bar moving.

(A) CODEBAR AND CODE LEVER CLEARANCE (Nonparity and Even Parity)

Requirement

Permutation must be such that highest level is spacing and located furthest right. While key is held down and cam cycled to stop position, gap between left hand side of key code lever and codebar blocked.

Min 0.006 inch---Max 0.017 inch

To Adjust

Position guide by adjusting slot with four mounting screws loosened.

2.26 Keyboard Mechanism (continued)

(B) CLUTCH TRIPBAR SPRING (Even Parity)

Requirement

Clutch disengaged and power off
 Min 8 oz---Max 12 oz
 to move bar.

(C) CODEBARS, SHIFT AND CONTROL LOCKBAR, COUNTER AND COUNTER RETURN BAR SPRINGS (Even Parity)

Requirement

Depress rubout or delete key. Power off. Transfer levers held right.

Min 2 oz---Max 4 oz
 for all remaining bars.

Min 5 oz---Max 7-1/2 oz
 for 1 through 8 codebars to start each bar moving.

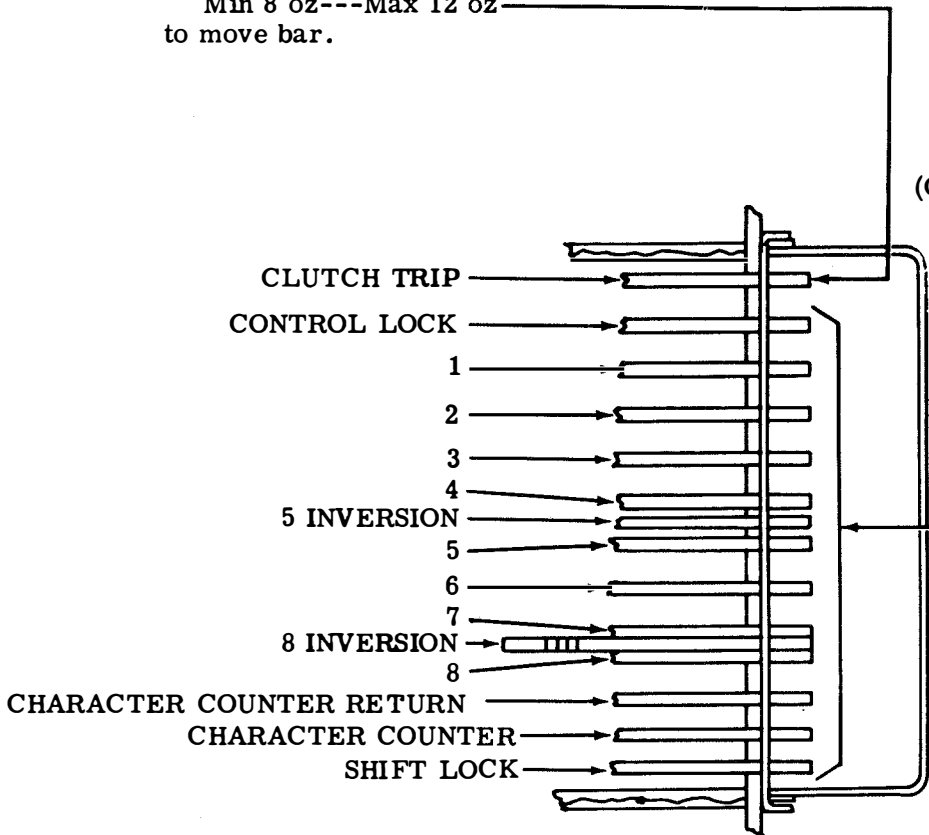

(D) NO. 5 AND NO. 8 INVERSION BAR SPRINGS (Even Parity)

Requirement

With codebar in latched position unhook spring at guide

Min 2 oz---Max 4 oz
 to pull to installed length.

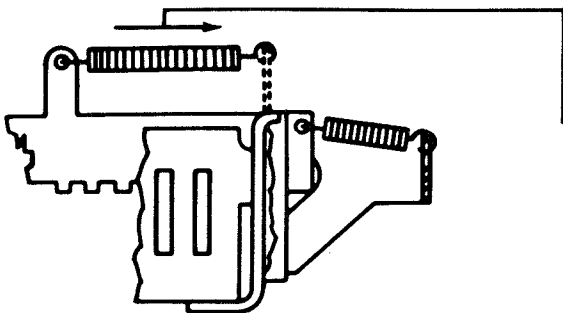

(A) CODEBAR AND CODE LEVER CLEARANCE (Nonparity and Even Parity)

See 2.25

2.27 Keyboard Mechanism (continued)

(A) FUNCTION BAIL LEVERS AND CODE LEVER CLEARANCE**Requirement**

Function bails should operate within their guides without binding.

To Adjust

Position function bail assembly with two mounting studs loosened, one at each end.

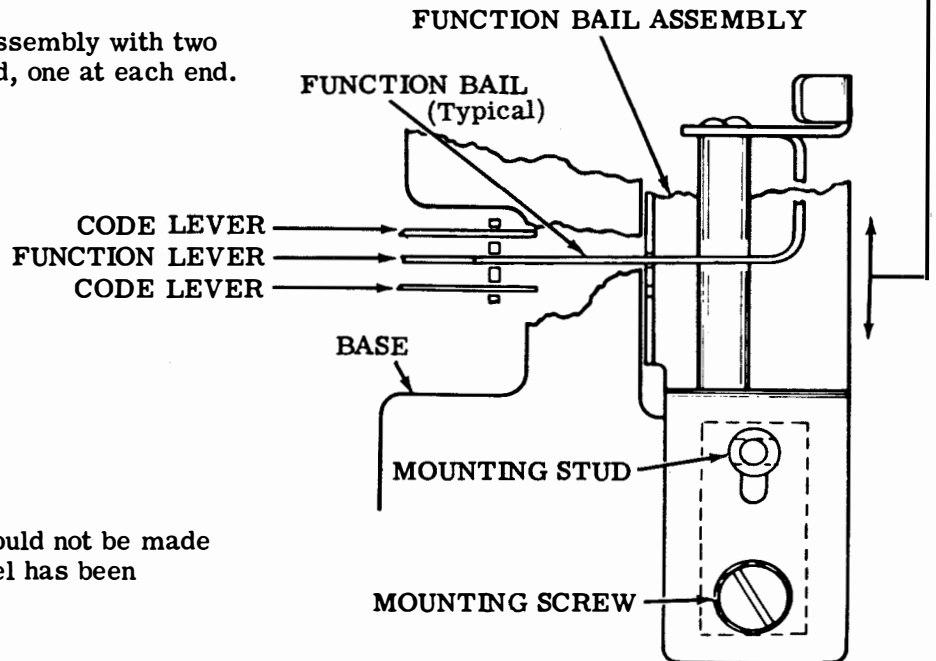
(B) LOCK BALL CHANNEL

Note: This adjustment should not be made unless the lock ball channel has been disassembled.

To Check

Remove the lock ball retainer. Remove a wedge from each end and one from the center in order to view the position of the code lever.

Requirement

There should be some to 0.006 inch clearance between end of lock ball channel and adjusting screw when most of the code levers are centrally located in the lock ball channel slots.

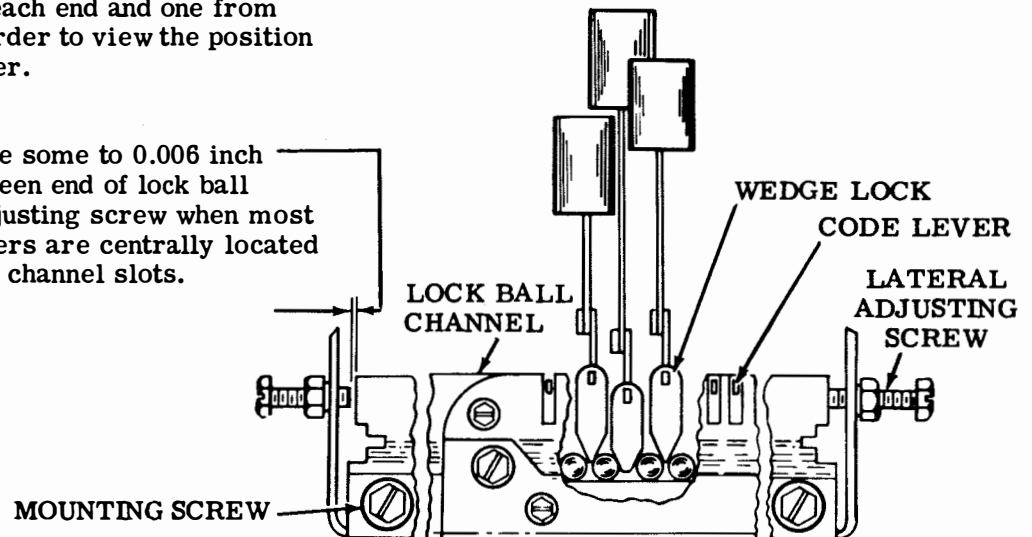
**To Adjust**

Loosen the lock ball channel mounting screws. Back off lateral adjusting screws and position channel. Turn one adjusting screw in against the end of the channel and lock it. Turn the other adjusting screw in to the end of the channel and back it off 1/4 turn. Lock the screw. Replace the wedges and check their position with respect to the balls. Pull channel assembly downward until all code levers strike their upstop without wedges jumping out of position. Replace lock ball retainer. Back off ball endplay adjusting screw.

2.28 Keyboard Mechanism (continued)

(B) LOCK BALL CHANNEL ENDPLAY (PRELIMINARY)

To Check

Depress return key with 32 oz pressure with ball end-play adjustment screw backed off.

Requirement

Clearance between balls should be minimum.

To Adjust

Maintain 32 oz pressure and rotate adjusting screw with fingers until a slight resistance is felt. Tighten locknut.

Note: A total of 53 balls are required in the ball track assembly.

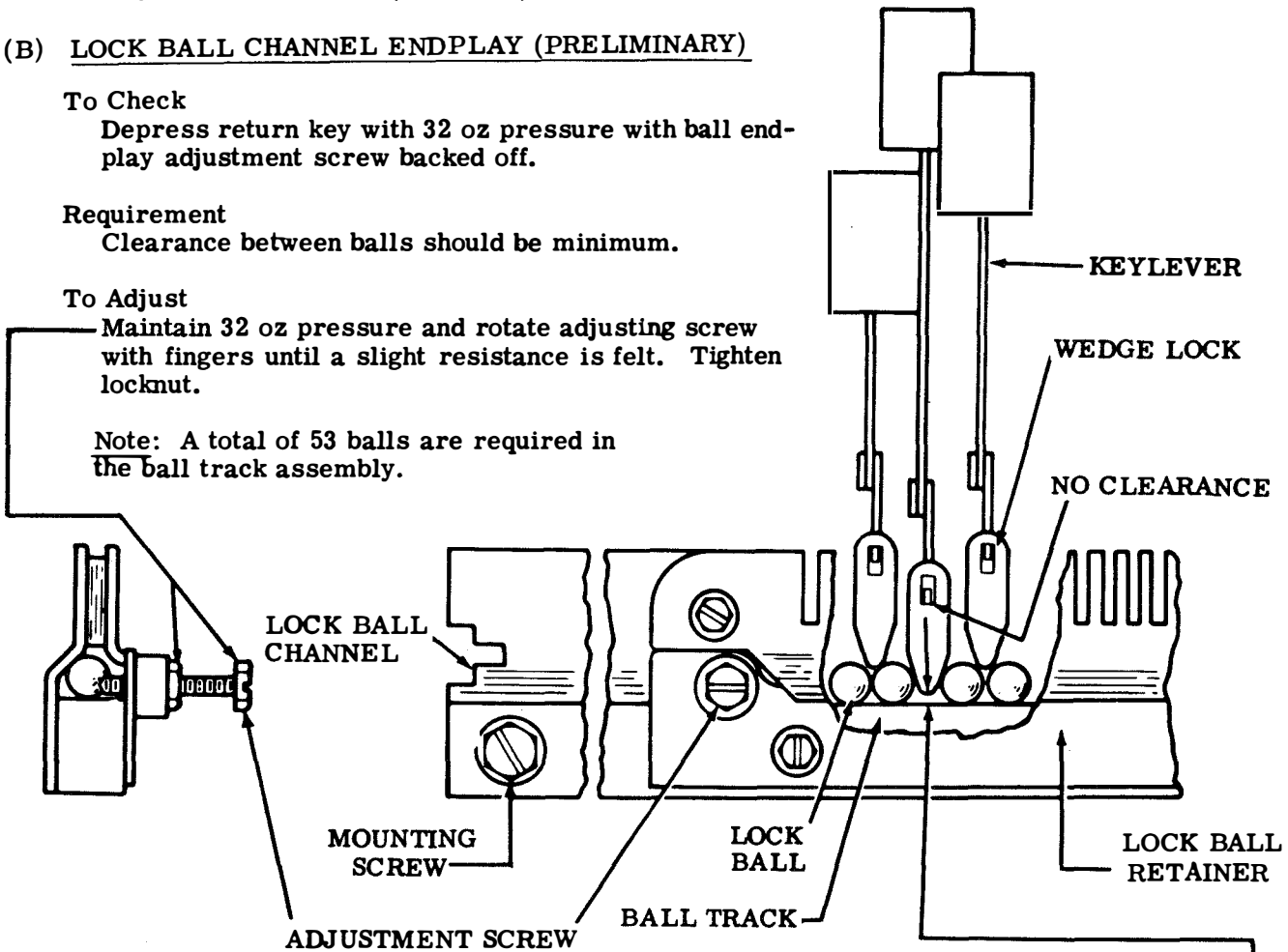

(A) BALL WEDGE LOCK AND BALL TRACK CLEARANCE (PRELIMINARY)

To Check

Depress Q and P keylever alternately with 32 oz pressure and measure clearance in each instance. There should be no clearance between lower edge of code lever extensions and bottom of slots in wedges.

Requirement

Clearance between tip of wedge and ball track
 Min 0.005 inch---Max 0.015 inch
 and equal within 0.005 inch.

To Adjust

Position ball track up or down with the two mounting screws loosened.

Note: Remove keyboard hood in order to make this adjustment. See disassembly and reassembly section.

2.29 Keyboard Mechanism (continued)

(B) UNIVERSAL BAIL LATCH SPRING

Requirement

Clutch disengaged, universal bail held away from latchlever

Min 7-1/2 oz---Max 11 oz
to start latchlever moving.

(A) UNIVERSAL BAIL LATCHLEVER
(PRELIMINARY)

To Check

Depress G key slowly with 32 oz pressure. Manually rotate universal bail backwards and release quickly.

Requirement

Clearance between universal bail latchlever and roller on universal bail extension

Min 0.015 inch---Max 0.025 inch

To Adjust

Loosen the three screws that fasten the universal bail rear blade. Rotate eccentric. Keep high part of eccentric up. It will be necessary to remake the adjustment UNIVERSAL BAIL REAR BLADE (2.30).

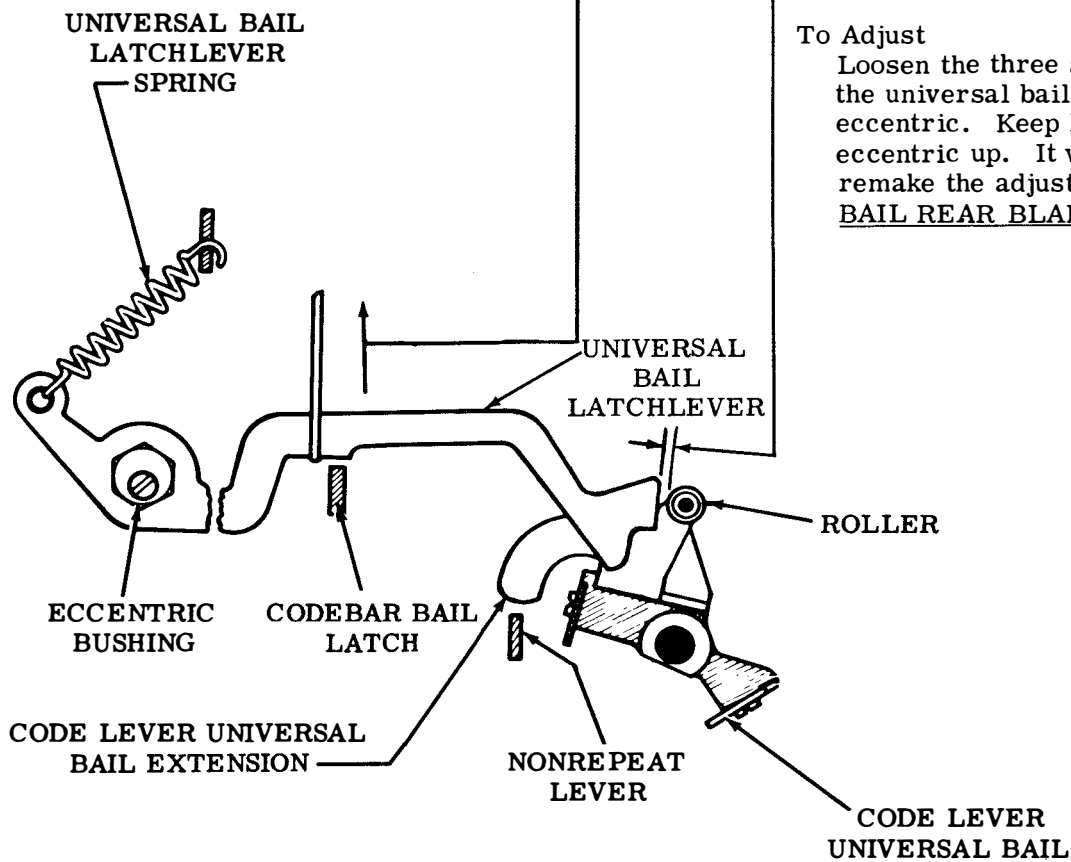

2.30 Keyboard Mechanism (continued)

(C) UNIVERSAL BAIL EXTENSION

To Check

Depress rubout keylever and release it. Check clearance.

Requirement (power off)

Universal bail extension roller resting against end of universal bail latchlever

Min 0.050 inch---Max 0.080 inch between extension and nonrepeat lever.

To Adjust

Position the extension with its clamp screw loosened.

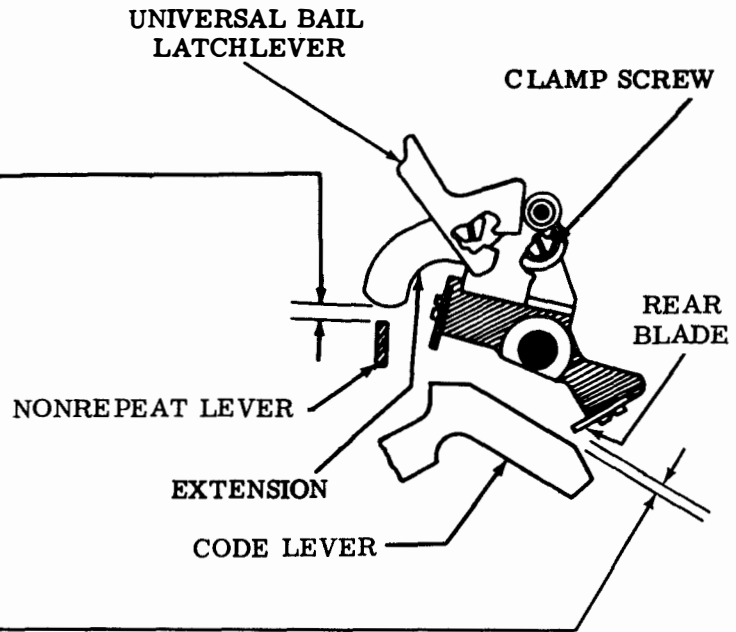

(E) UNIVERSAL BAIL REAR BLADE

Requirement

Initial trip-off condition, no key depressed, no power, universal bail extension post against end of latch.

Min some---Max 0.015 inch between universal bail blade and any code lever.

To Adjust

Position rear blade with mounting screws loosened.

(D) BALL-LOCK-WEDGE, BALL ENDPLAY, AND UNIVERSAL BAIL LATCH (FINAL)

(1) Requirement (under power)

Trip off pressure of any third row key should be
Min 2 oz---Max 6 oz

(2) Requirement

Apply 6-1/2 oz pressure perpendicular to the A key, depress each key in third row. The A key should trip each time a key is released.

(3) Requirement

Repeat (2) with the 6-1/2 oz pressure on return key.

(4) Requirement

The clutch should not trip when two keys are depressed simultaneously.

To Adjust

If necessary, refine BALL WEDGE LOCK AND BALL TRACK CLEARANCE (PRELIMINARY) (2.28), LOCK BALL ENDPLAY (PRELIMINARY) (2.28), UNIVERSAL BAIL LATCHLEVER (PRELIMINARY) (2.29), and UNIVERSAL BAIL EXTENSION (2.30).

2.31 Keyboard Mechanism (continued)

CODEBAR RESET BAIL SPRING

Requirement

Clutch disengaged and spring unhooked from arm

Min 9 oz---Max 11 oz
to pull to installed length.

CODEBAR RESET
BAIL SPRING
ASSEMBLY

CODEBAR RESET BAIL

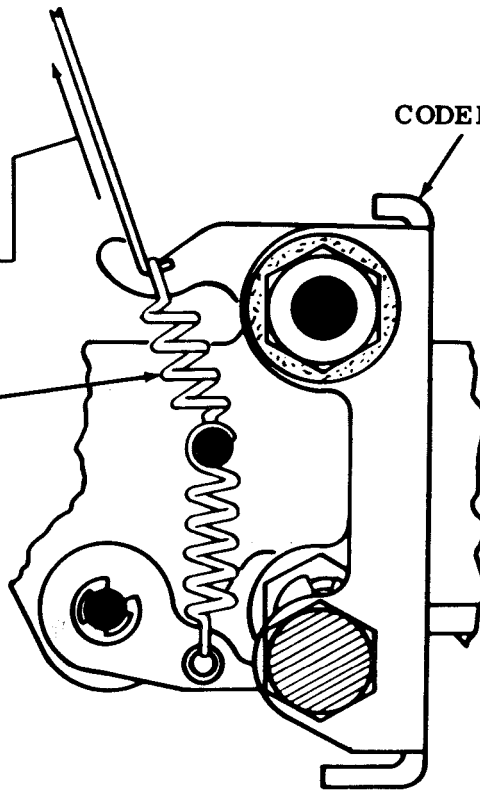

2.32 Keyboard Mechanism (continued)

(A) CODEBAR RESET BAIL

Requirement

Cam eccentric and arm holding bail
extreme reset position to left.

Min some---Max 0.006 inch
between roller bearing mounted on
reset bail and reset bail latch.

To Adjust

Adjust eccentric stud with locknut
loosened.

(B) CODEBAR RESET BAIL LATCH SPRING

Requirement

Min 1/2 oz---Max 1-1/2 oz
to start codebar reset bail latch
moving.

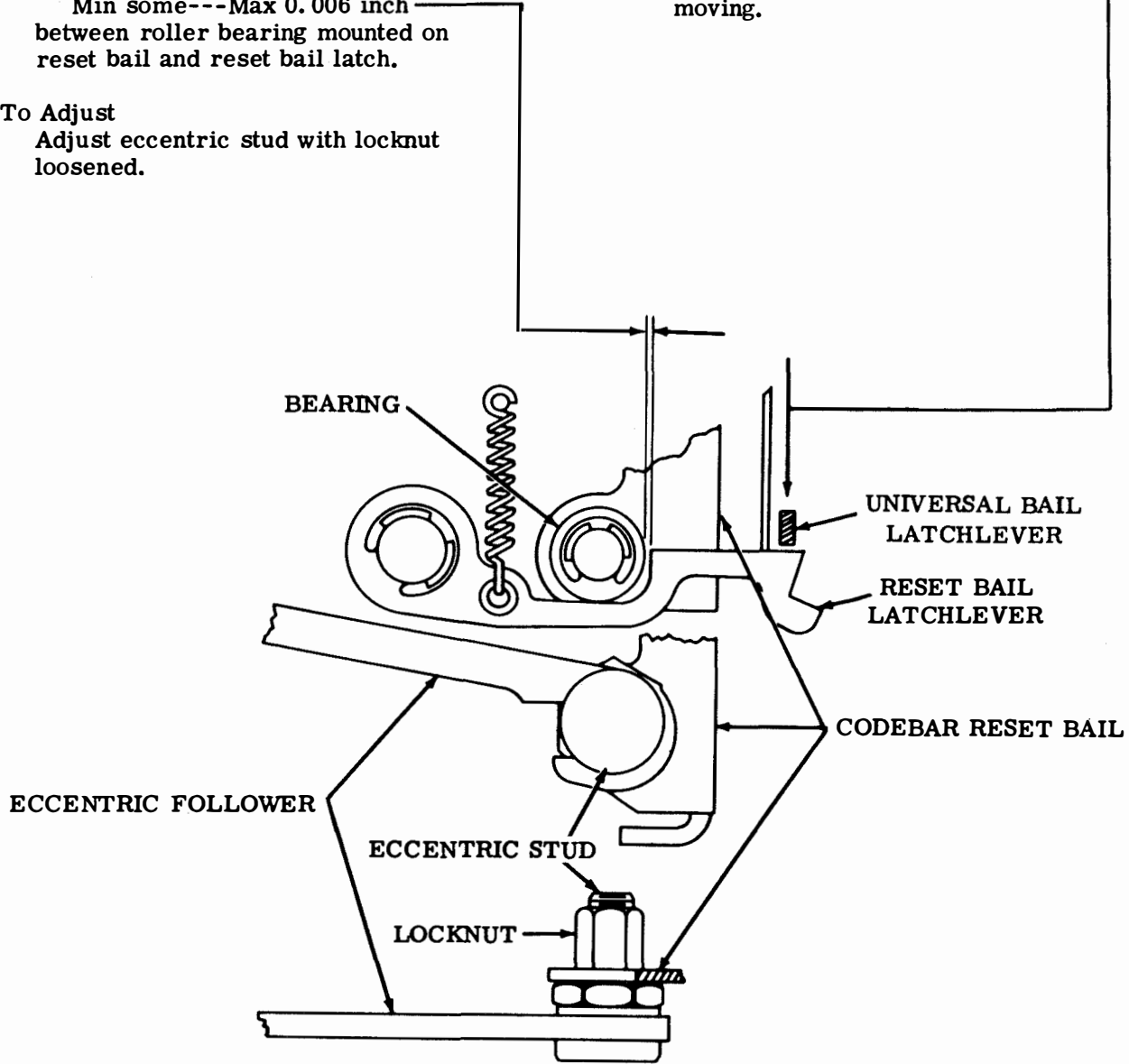

2.33 Keyboard Mechanism (continued)

(B) NONREPEAT LEVER SPRING

Requirement

Clutch disengaged. Any keylever depressed.

Min 2-1/4 oz---Max 3-1/4 oz
to start nonrepeat lever moving downward.

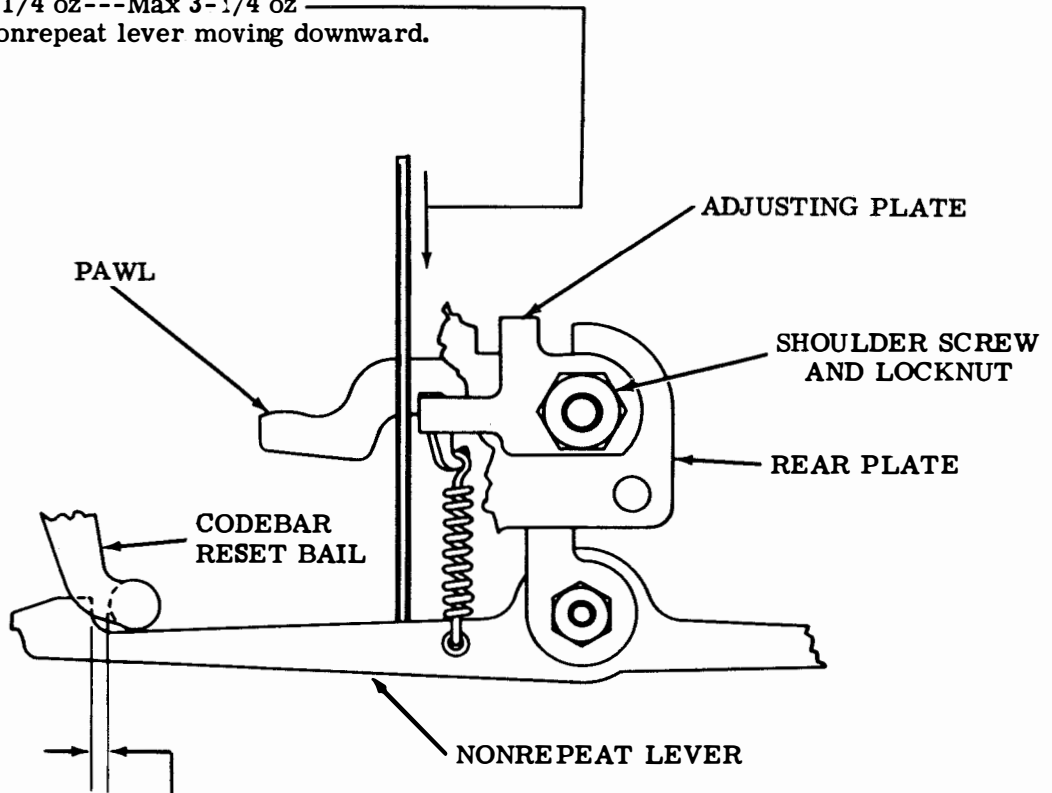

(A) CODEBAR RESET BAIL AND NONREPEAT LEVER

Requirement

Mechanism in initial trip-off condition, any key depressed, and no power.

Min some---Max 0.010 inch
between roller of reset bail and nonrepeat lever pick-up step.

Note: Do not permit clutch to rotate when tripping off.

2.34 Keyboard Mechanism (continued)

INVERSION CODEBAR LATCH (Even Parity)

Requirement

Signal generator clutch disengaged.

Min 0.002 inch---Max 0.012 inch gap between number 5 and 8 inversion codebars and their respective latches. Check clearance at both the number 5 and 8 inversion codebars and adjust to whichever is closest.

To Adjust

With respective screws on inversion bail latch friction tight, move adjustable extension to obtain clearance. Tighten screws and recheck clearance.

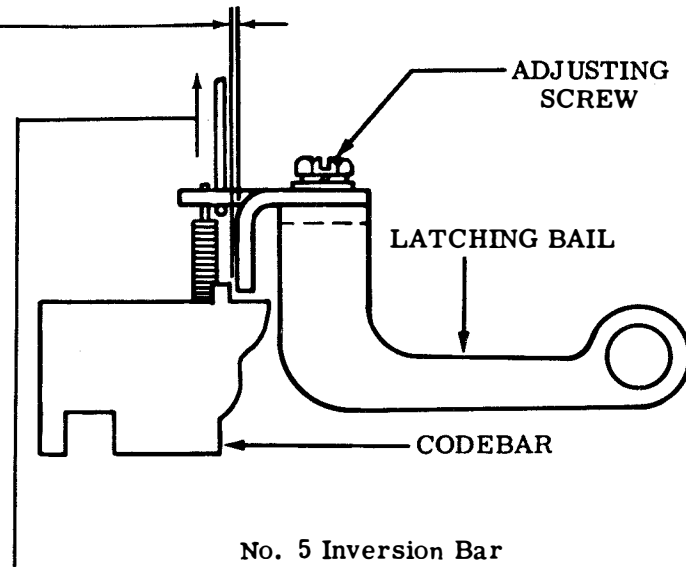

INVERSION BAR LATCHING BAIL SPRING (Even Parity)

(1) Requirement

Min 2-1/2 oz---Max 3-1/2 oz to move bail.

(2) Requirement

Min 1-1/2 oz---Max 2-1/2 oz to move bail.

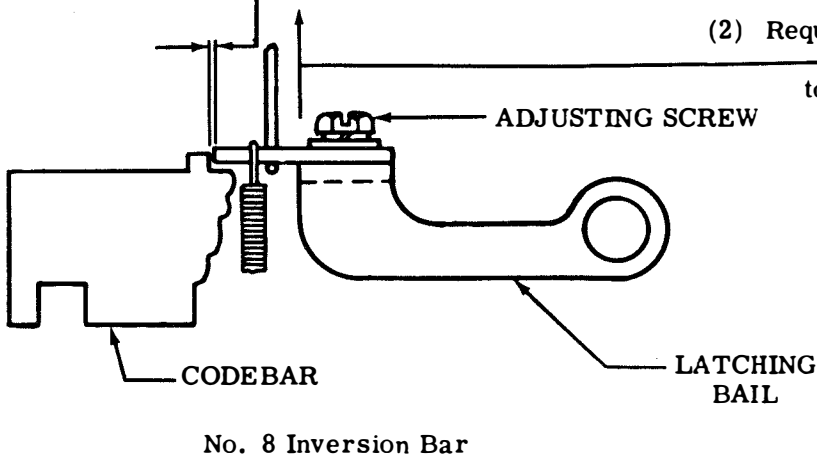

2.35 Character Counter Mechanism

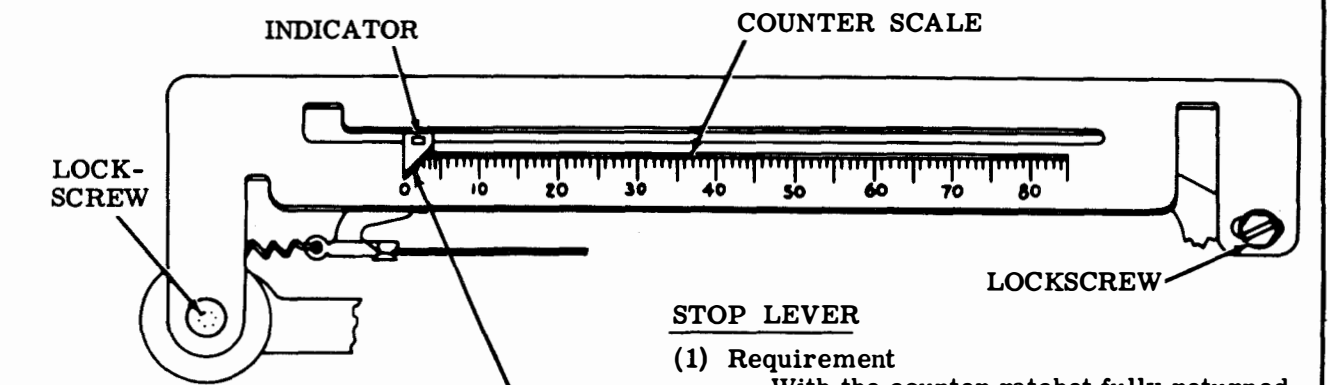
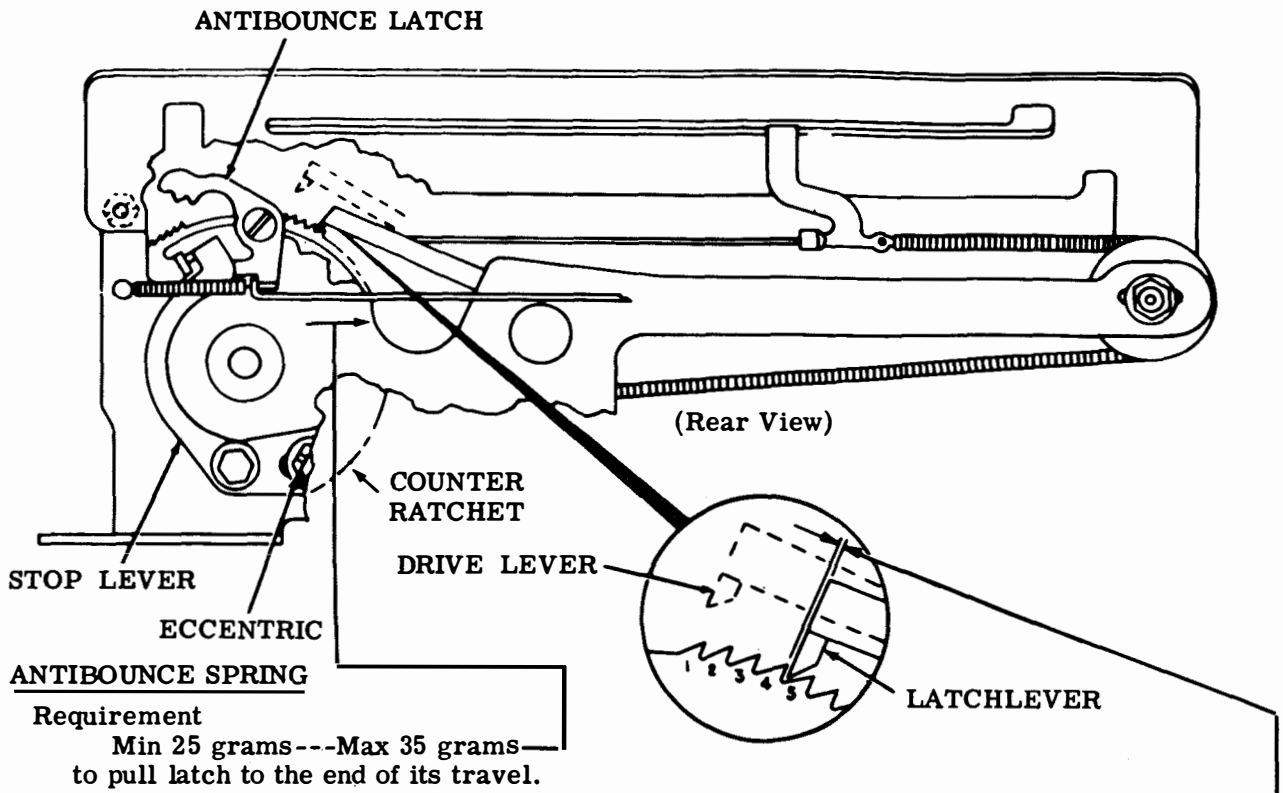

CHARACTER COUNTER SCALE

- (1) Requirement
When indicator is at extreme left of scale, it should point to zero.
To Adjust
Set indicator to left. Loosen lock-screws and position scale.
- (2) Requirement
Point of indicator should not touch throughout its entire travel.
To Adjust
Form the indicator.

STOP LEVER

- (1) Requirement
With the counter ratchet fully returned and resting against its stop lever, the clearance between the latchlever and the face of the 4th ratchet tooth should be
Min 0.002 inch---Max 0.010 inch
- (2) Requirement
The antibounce latch should not interfere with the rotation of the ratchet
To Adjust
Hold the drive lever out of engagement with the ratchet and rotate the stop lever eccentric.

2.36 Character Counter Mechanism (continued)

RATCHET DRUM ASSEMBLY RETURN SPRING

Requirement

1/2 to 1-1/2 oz when indicator points to 35 on the scale.

1-1/2 to 2-1/2 oz when indicator points to 70 on the scale.

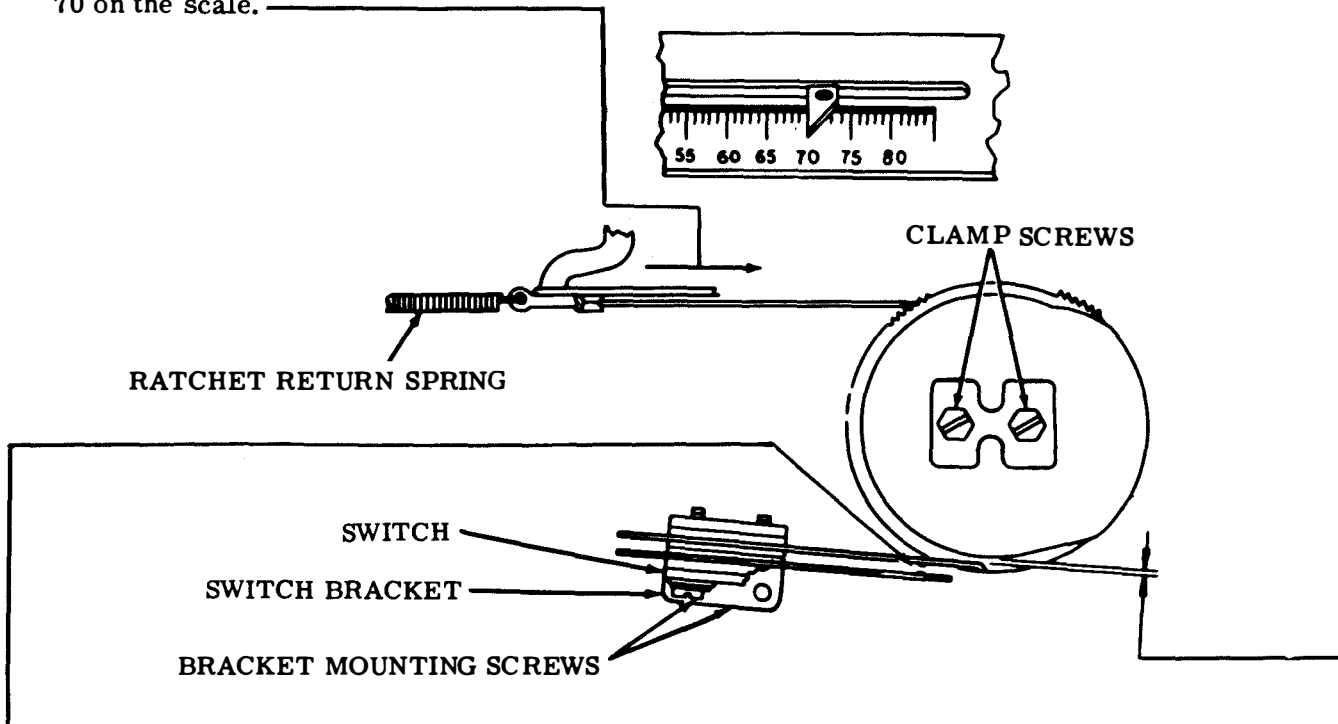

CHARACTER COUNTER END-OF-LINE SWITCH

(1) Requirement
The switch should close at a preset number of characters.

(2) Requirement
Before installing the counter on the keyboard, tighten the clamp screws and switch bracket mounting screws friction tight. Make adjustment with the switch leaf springs approximately parallel to the switch mounting bracket (gauge by eye) and with
Min 0.005 inch---Max 0.020 inch
clearance between the leaf spring switch contacts (bend lower leaf spring).

To Adjust
Position switch bracket until the upper switch leaf spring clears the low of the cam
Min some---Max 0.025 inch

Check closest point and tighten bracket screws. Set indicator to count desired and adjust cam until the switch just closes. Tighten clamp screws.

To Check
Move ratchet drum until the indicator traverses the entire scale. The switch should close on the desired count, with a small amount of overtravel of both blades. It may be necessary to refine the above adjustments when operating on the extreme ends of the 65 to 80 character range.

2.37 Character Counter Mechanism (continued)

CHARACTER COUNTER STROKE

(1) Requirement

When character and repeat keys are depressed, the counter should operate. When carriage return key is depressed, the counter should reset without binding. The mechanism should count the first character on a restart after reset condition.

(2) Requirement

There should be
 Min 0.006 inch---Max 0.015 inch
 between drive lever and ratchet tooth when counter is set near midpoint of its range.

To Adjust

Loosen mounting screws. Position character counter frame for clearance.

RESET LATCHLEVER AND DRIVE LEVER SPRING

Requirement

Min 1/2 oz---Max 1 oz
 to move either lever

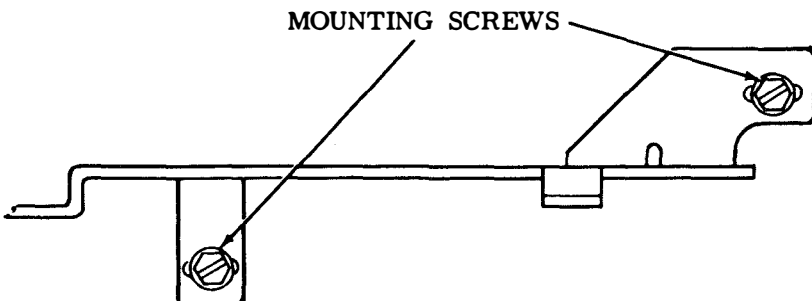
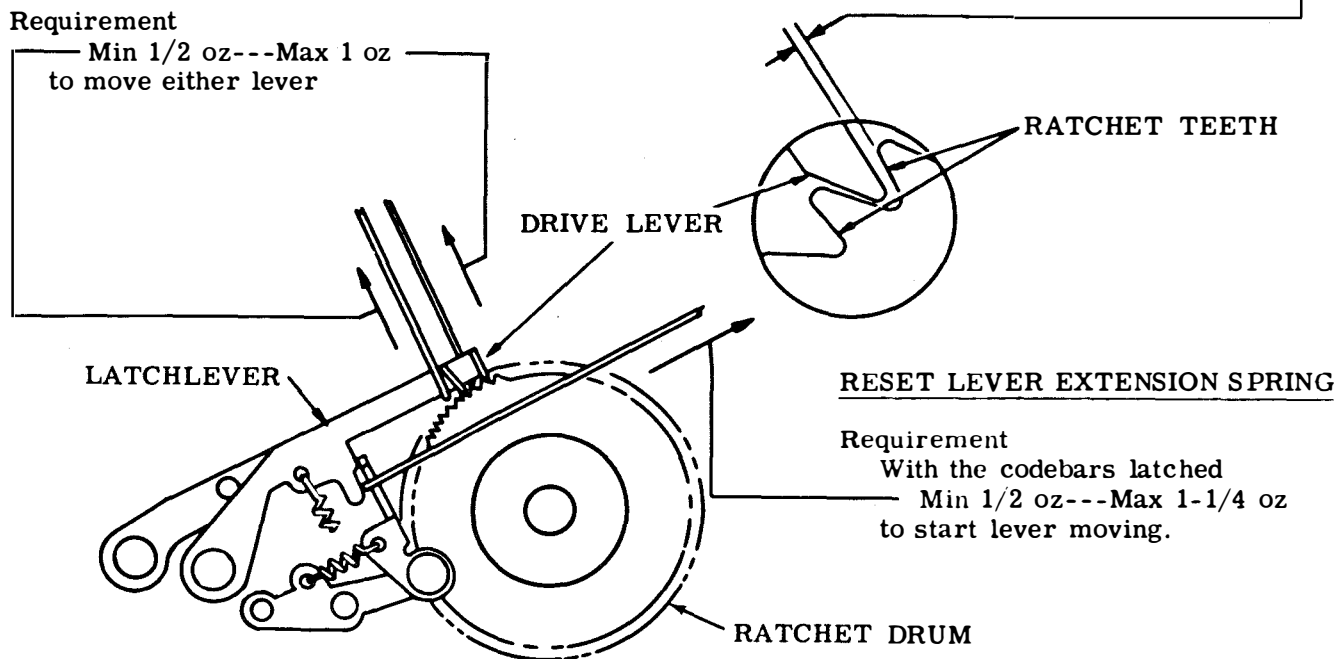

2.38 Clutch Release Lever Mechanism

(B) CLUTCH RELEASE LEVER AND TRIP LEVER ALIGNMENT (Early Design)

To Check

Manually move main trip lever to release clutch lever. Rotate drive shaft until clutch is released.

Requirement

Perforator in its stop position

Max 0.010 inch clearance between main trip lever and clutch release lever.

To Adjust

With its clamp screw loosened, position main trip lever to meet requirement.

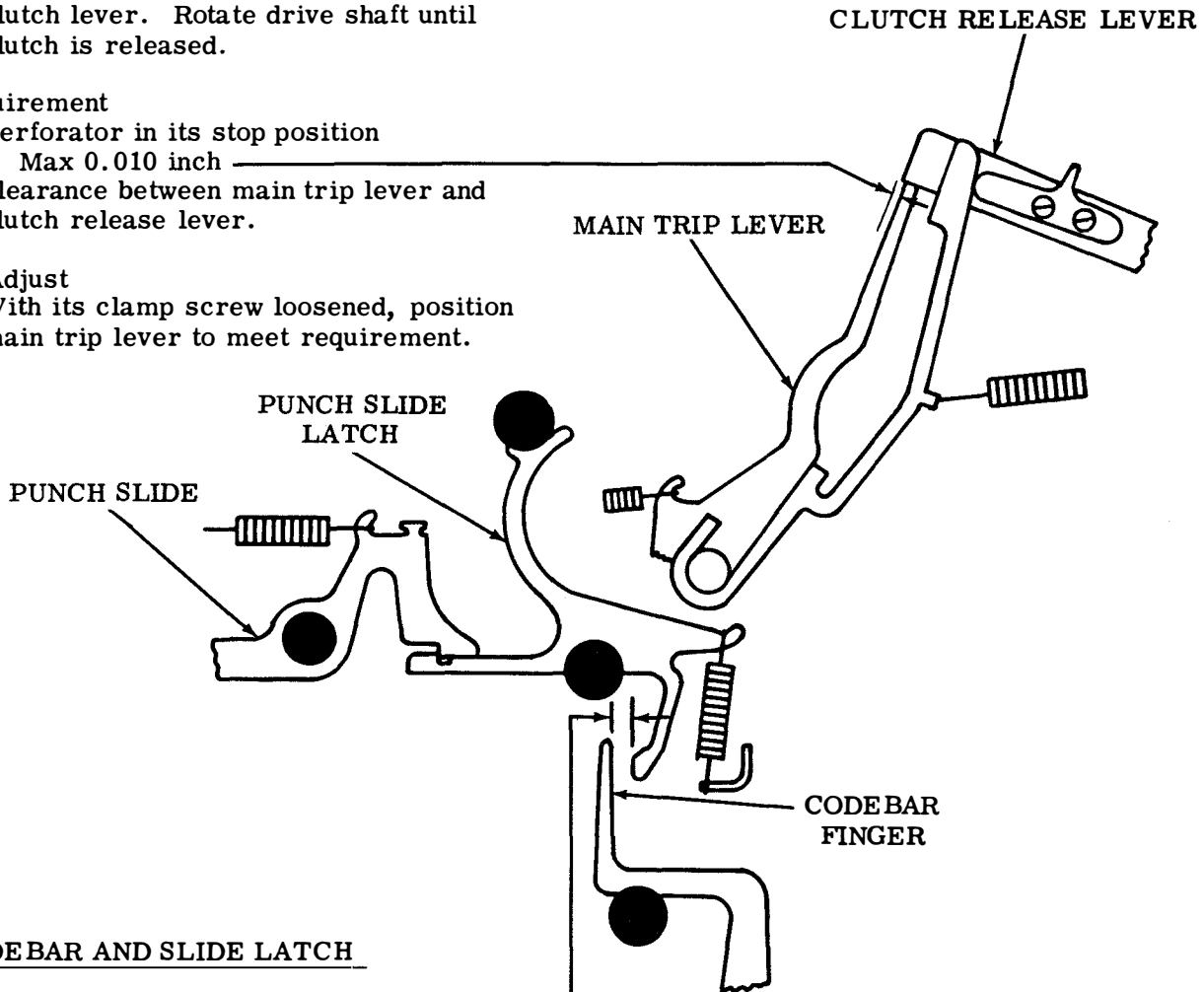

(A) CODEBAR AND SLIDE LATCH

(1) Requirement

With punch in stop position and codebar bail latched in stop position

Min 0.055 inch---Max 0.065 inch clearance between punch slide latch and its respective codebar finger on the innermost and outermost slide latches.

(2) Requirement

Punch slide latch and its respective codebar finger should align as gaged by eye from the top of the unit.

To Adjust

With mounting screws loosened, slide perforator left or right to meet clearance and alignment requirements.

2.39 Clutch Release Lever Mechanism (continued)

CLUTCH RELEASE LEVER (Early Design)

To Check

Remove clutch release lever spring. Depress letters or rubout key. Carefully move clutch release lever so its lower edge is just below top edge of main trip lever but not far enough to release the clutch nor to disengage the trip lever release lug from the trip lever operating arm.

Requirement

Min some---Max 0.015 inch clearance between end of clutch release lever and main trip lever.

To Adjust

Loosen screw on trip lever operating arm extension and adjust to meet requirement. Tighten screw. Check adjustment by manually depressing clutch release lever to release clutch and rotate shaft through one cycle. Check adjustment and refine if necessary.

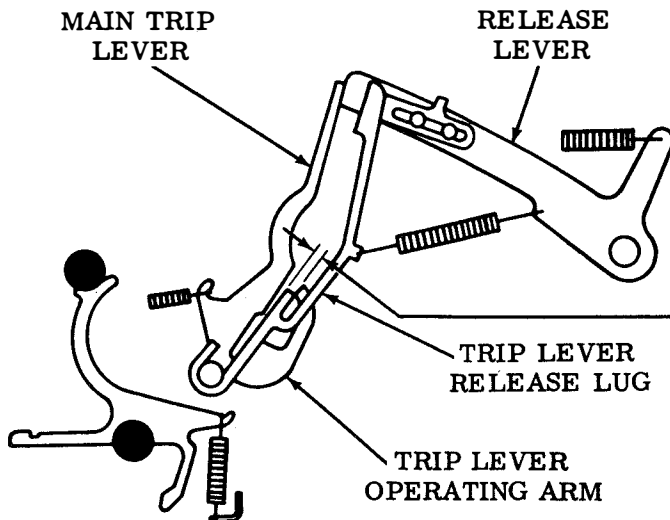
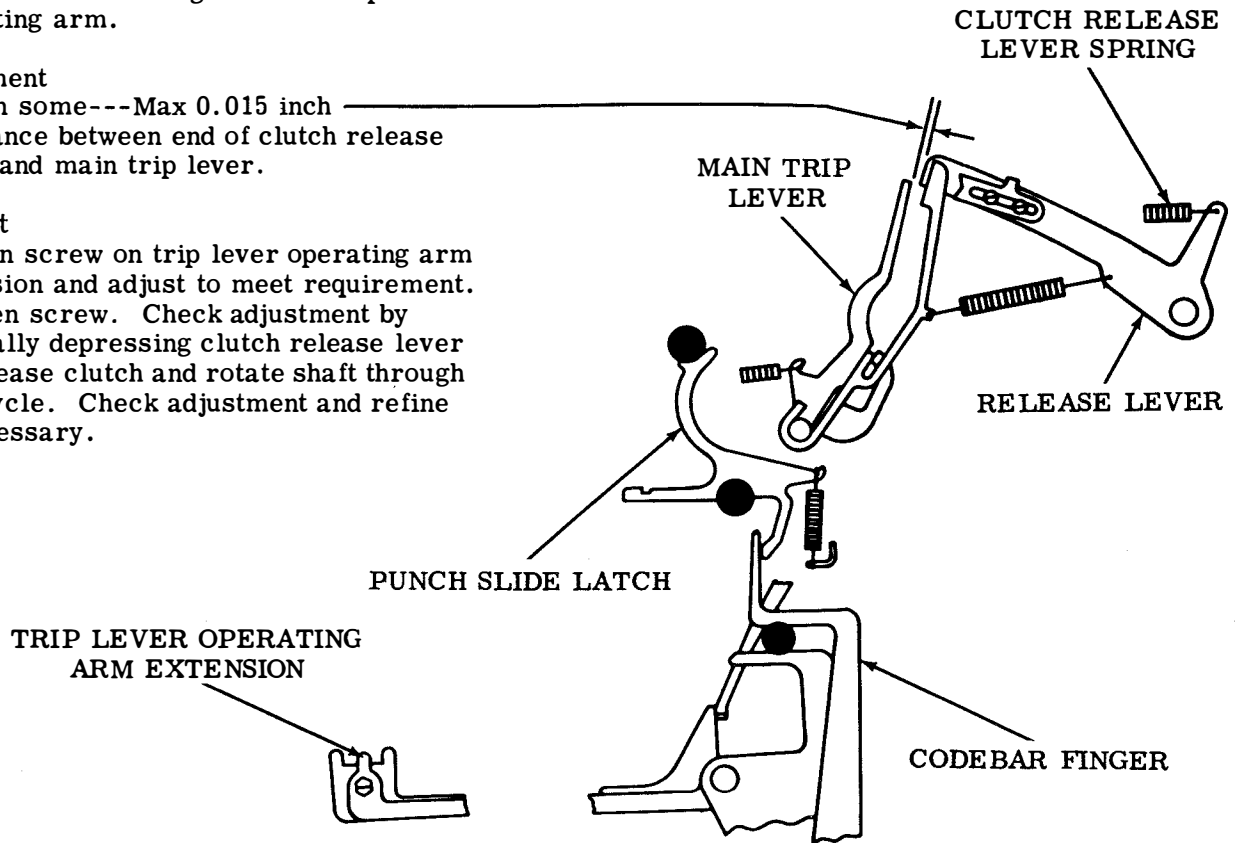

TRIP LEVER RELEASE BACKSTOP (Early Design)

Requirement

Unit in stop position, top of codebar return arm on high part of cam.

Min some---Max 0.006 inch clearance between main trip lever and trip lever release lug.

To Adjust

With screws loosened, position backstop to meet requirement.

2.40 Clutch Release Lever Mechanism (continued)

CLUTCH RELEASE LEVER (Late Design)

To Check

Remove clutch release lever spring. Depress letters or rubout key. Carefully move clutch release lever so its lower edge is just below top edge of main trip lever but not far enough to release the clutch nor to disengage the trip lever release lug from the trip lever operating arm.

(1) Requirement

Min some _____ clearance between end of clutch release lever and main trip lever.

(2) Requirement

Some clearance between main trip lever and downstop bracket. _____

To Adjust

Loosen screw on trip lever operating arm extension and adjust to meet requirement. Tighten screw. Check adjustment by manually depressing clutch release lever to release clutch and rotate shaft through one cycle. Check adjustment and refine if necessary.

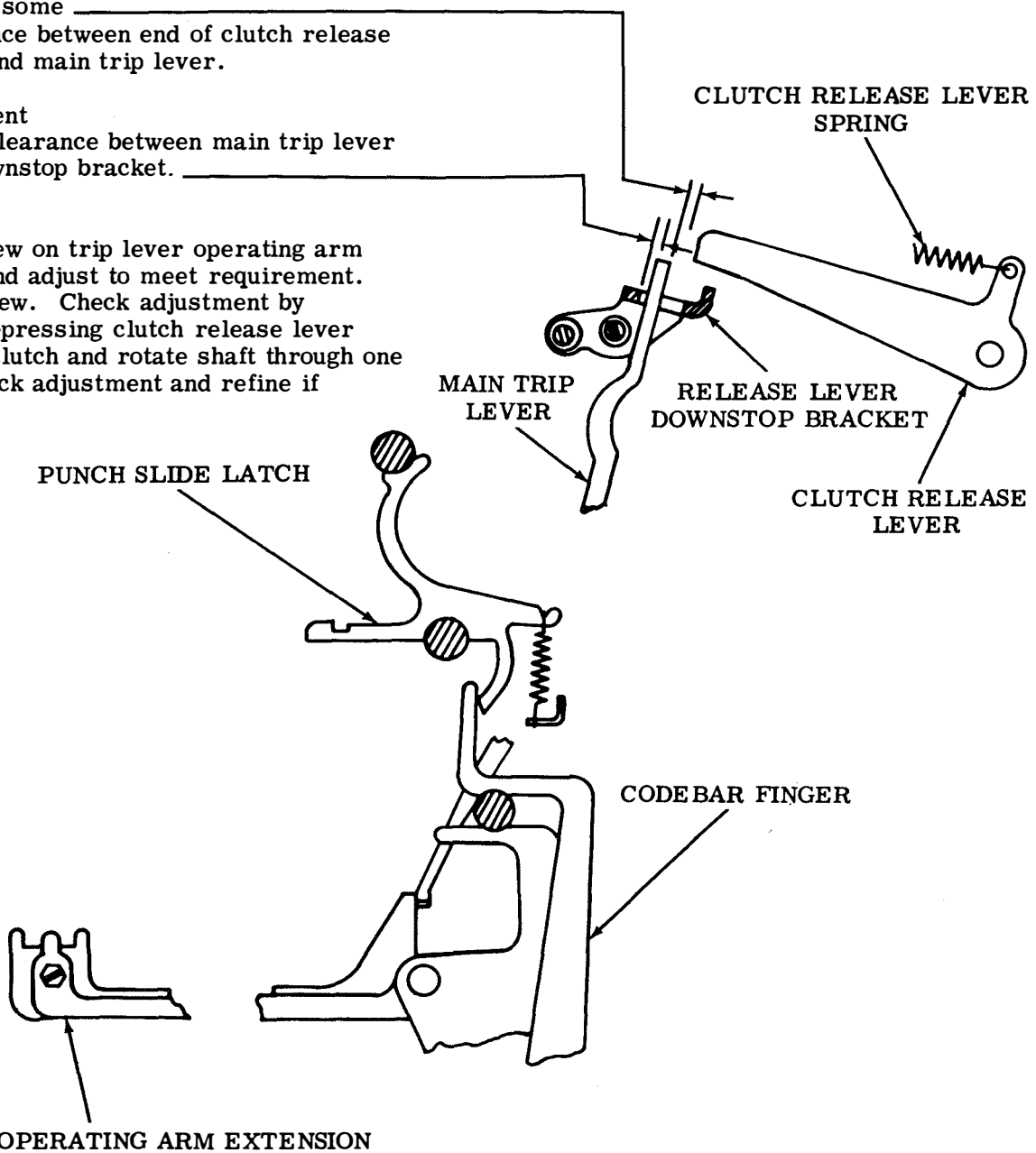

2.41 Clutch Release Lever Mechanism (continued)

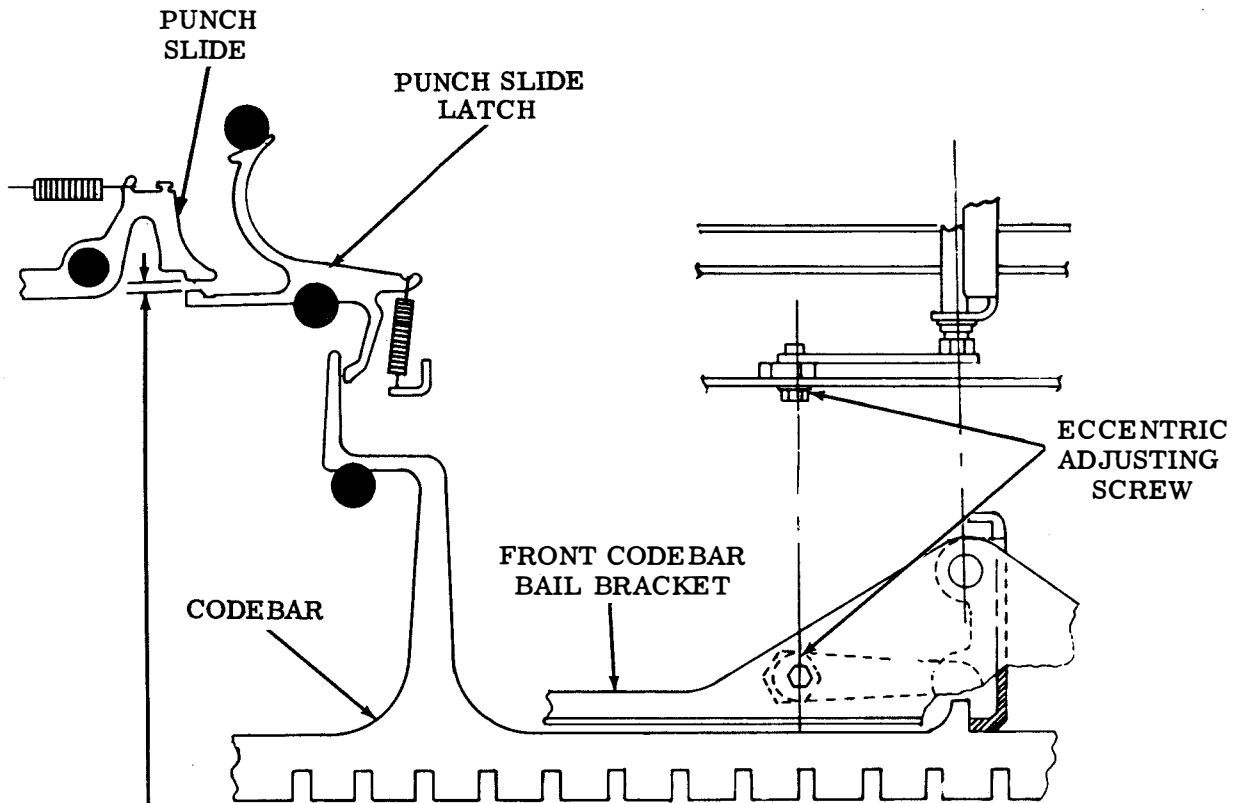
PUNCH SLIDE LATCH CLEARANCE

- (1) Requirement (nonparity)
With letters or rubout key depressed
— Min 0.015 inch---Max 0.045 inch
clearance between punch slide and punch slide latch.
- (2) Requirement (parity)
With rubout key depressed
— Min some---Max 0.045 inch
clearance between punch slide latch when inversion bars
are marking.
- (3) Requirement
In the stop position, punch slides should be fully latched.

To Adjust

With eccentric adjusting screw loosened, rotate bail about pivot to meet requirement.

2.42 Codebar Mechanism

CODEBAR RETURN CAM FOLLOWER BRACKET

BRACKET MOUNTING SCREWS

Requirement

Bracket positioned so roller rides fully on cam. There should be Min 0.020 inch clearance between head of link shoulder screw and clutch latchlever.

To Adjust

With bracket screws loosened, position bracket to meet requirement.

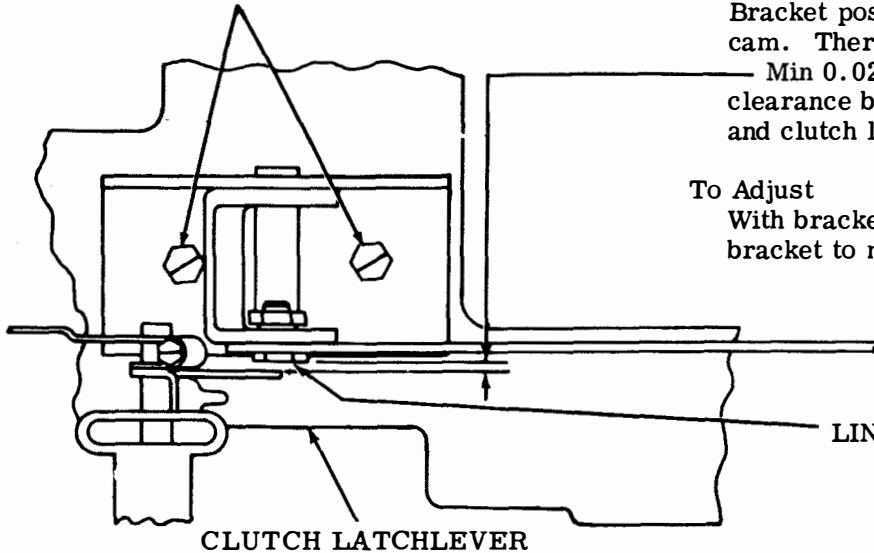

LINK SHOULDER SCREW

CLUTCH LATCHLEVER

CODEBAR RETURN ARM BRACKET

Requirement

Bracket positioned so clutch bar operating link is parallel with clutch bar and return lever shaft is parallel with right edge of base. Both requirements are to be gaged by eye.

To Adjust

With mounting screws loosened, position bracket to meet requirements.

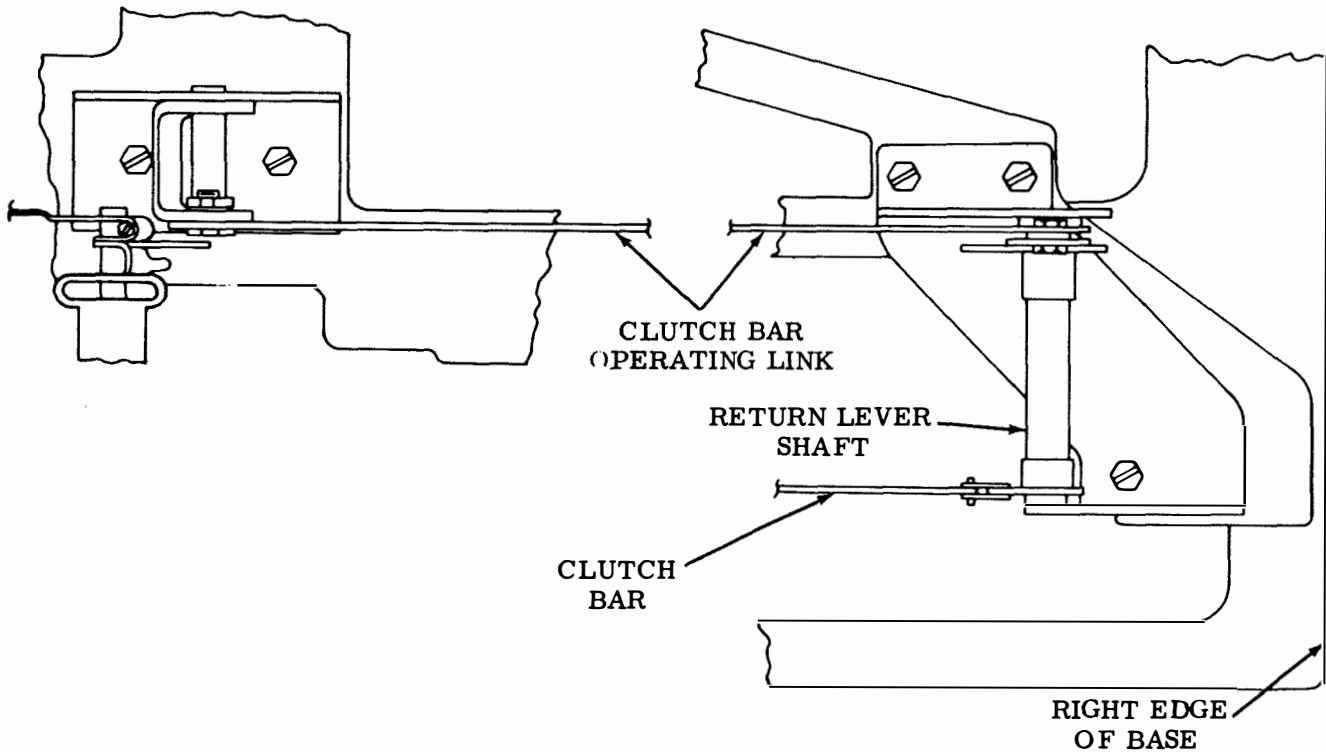

CLUTCH BAR
OPERATING LINK

RETURN LEVER
SHAFT

CLUTCH
BAR

RIGHT EDGE
OF BASE

2.43 Codebar Mechanism (continued)

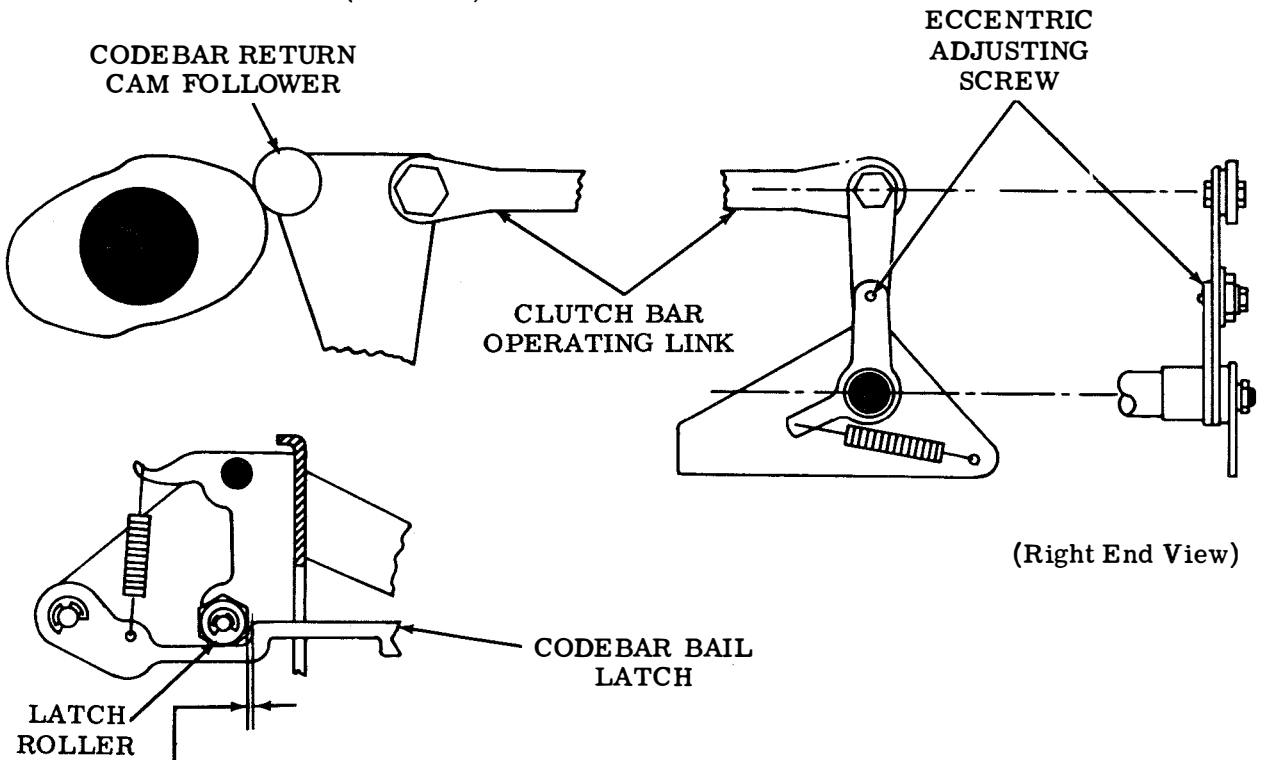

CODEBAR BAIL LATCH

Requirement

Codebar return cam follower on high point of return cam
 Min some---Max 0.008 inch
 clearance between codebar bail latch and latch roller on cam. Check
 on each of two high points of cam.

To Adjust

With screw loosened, adjust eccentric to meet requirement. Rotate
 drive shaft through stop position until follower is again on high point
 of reset bail. Recheck adjustment and refine if necessary.

2.44 Motor

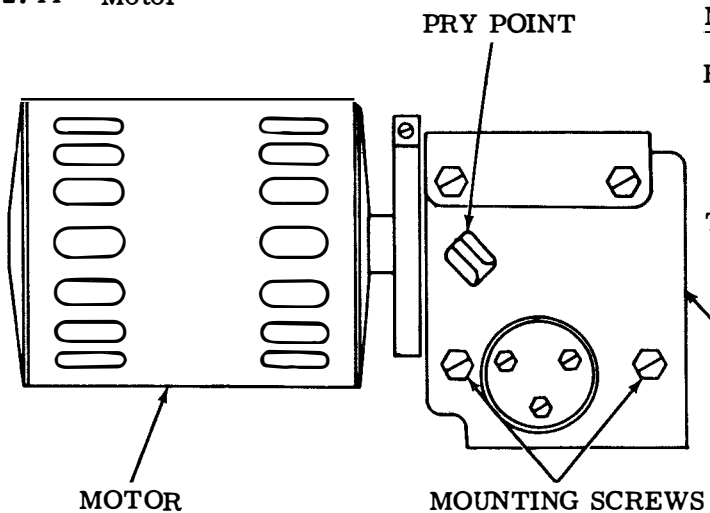

MOTOR PINION AND GEAR BACKLASH

Requirement

With two shafts coupled, there should be a
 minimum perceptible backlash between
 gear and motor pinion.

To Adjust

With bracket mounting screws friction
 tight, position mounting plate to meet
 requirement by means of pry point.

2.45 Typing Mechanism

(A) ALIGNMENT (Preliminary)

To Check

Manually select rubout code combination (12345678)
 Rotate selector shaft until function clutch trips.
 Hold no. 2 and 3 bellcranks against stop post.

Requirement

Operating blade parallel to (not necessarily flush with) no. 2 and 3 pushbars.

To Adjust

With its mounting screws friction tight, pry transfer mounting bracket all the way to the right. Add or remove shims under the rear leg of the operating blade. Place extra shims on rear mounting screw between blade and flat washer. Tighten screws.

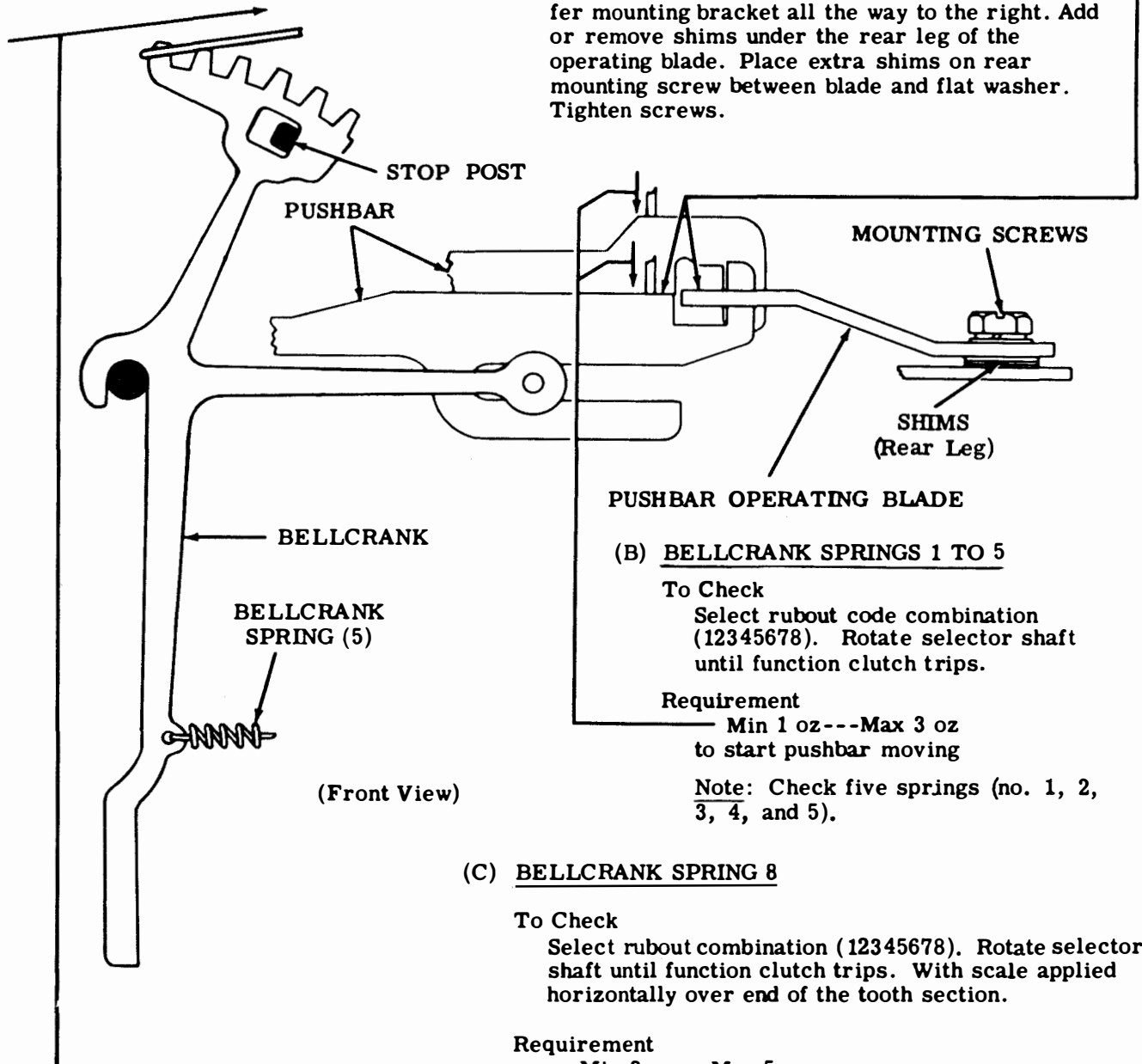

PUSHBAR OPERATING BLADE

(B) BELLCRANK SPRINGS 1 TO 5

To Check

Select rubout code combination (12345678). Rotate selector shaft until function clutch trips.

Requirement

Min 1 oz---Max 3 oz to start pushbar moving

Note: Check five springs (no. 1, 2, 3, 4, and 5).

(C) BELLCRANK SPRING 8

To Check

Select rubout combination (12345678). Rotate selector shaft until function clutch trips. With scale applied horizontally over end of the tooth section.

Requirement

Min 3 oz---Max 5 oz to start bellcrank moving.

2.46 Typing Mechanism (continued)

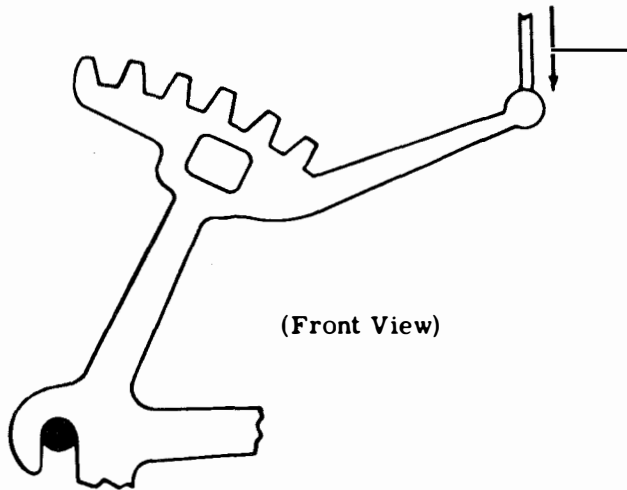

(Front View)

BELLCRANK SPRINGS 6 AND 7

To Check

Select rubout combination (12345678). Rotate selector shaft until function clutch trips.

- (1) Requirement (bellcrank spring 6)
With scale applied vertically to ball end of bellcrank contact operating
Min 2 oz---Max 4 oz
to start bellcrank moving.
- (2) Requirement (bellcrank spring 7)
With seven-pulse beam spring removed and scale applied vertically to ball end of bellcrank operating arm
Min 3 oz---Max 6 oz
to start bellcrank moving.

SHOULDER CLEARANCE

To Check

Manually select rubout code combination (12345678). Rotate selector shaft until function clutch trips. Manually seat pushbars in detented position. In bar which is nearest left edge of blade, take up play to left and rear, and then release.

- (1) Requirement
Clearance between bar and left edge of blade
Min 0.015 inch---Max 0.030 inch

- (2) Requirement
Some clearance between right edge of blade and pushbars when play in bars has been taken up to right and released.

- (3) Requirement
With unit in stop position, some clearance between right edge of blade and bars when play in bars has been taken up to right and released.

To Adjust

With mounting screws loosened, position operating blade in elongated holes. Tighten screws.

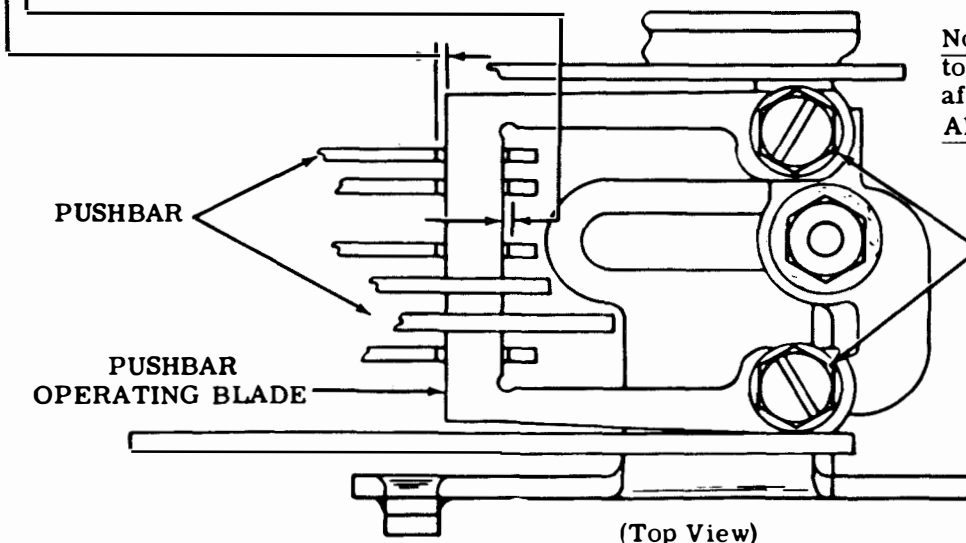

(Top View)

Note: It may be necessary to refine this adjustment after CENTERING CLEARANCE (2.47) adjustment.

2.47 Typing Mechanism (continued)

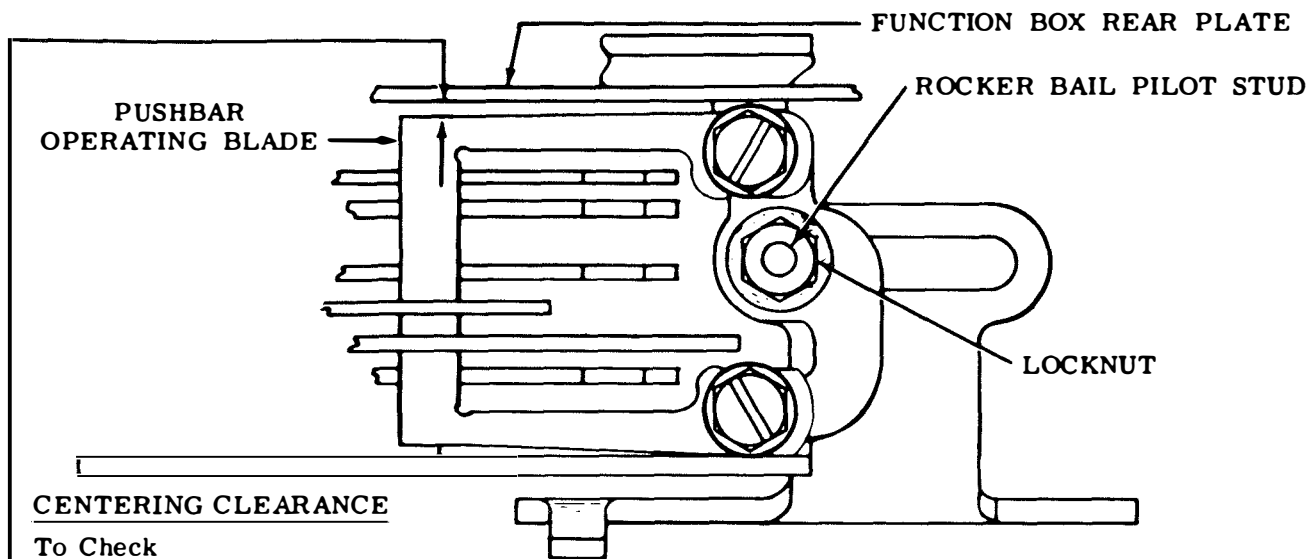

To Check

Manually select the null code combination (all spacing). Position rocker bail through a complete cycle to insure the clearance is a minimum.

Requirement

Clearance between function box rear plate and pushbar operating blade

Min 0.005 inch---Max 0.020 inch

at a point in the cycle where play is taken up to make clearance minimum.

To Adjust

Position rocker bail pilot stud in elongated hole with locknut loosened. Tighten nut.

(Top View)

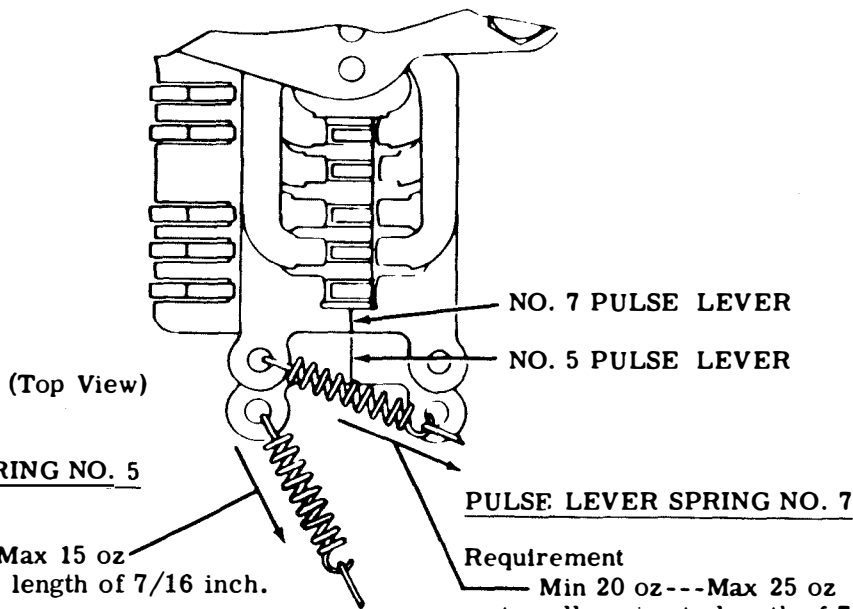

Requirement

Min 10 oz---Max 15 oz
to pull spring to length of 7/16 inch.

Requirement

Min 20 oz---Max 25 oz
to pull spring to length of 7/16 inch.

2.48 Typing Mechanism (continued)

BELLCRANK PUSHBAR ENGAGEMENT**Requirement**

With letters (rubout) pushbar to extreme right and fully detented, rubout code (12345678) selected, punch slides disengaged and function clutch tripped, eliminate play in downward direction, then release. Keep operating blade parallel with no. 2 and no. 3 pushbars and take up function box play in a clockwise direction. The top of the operating blade for 8-level units should be

Min flush---Max 0.020 inch
above top rubout pushbars.

For 5-level units

Min flush---Max 0.020 inch
below top of No. 2 and No. 3 pushbars.

To Adjust

- (1) Loosen two screws mounting function box to front plate spacer posts.
- (2) Using pry point, rotate entire function box. Check bellcrank spring bracket for proper location.
- (3) Take up spacer post play to right and tighten screws.

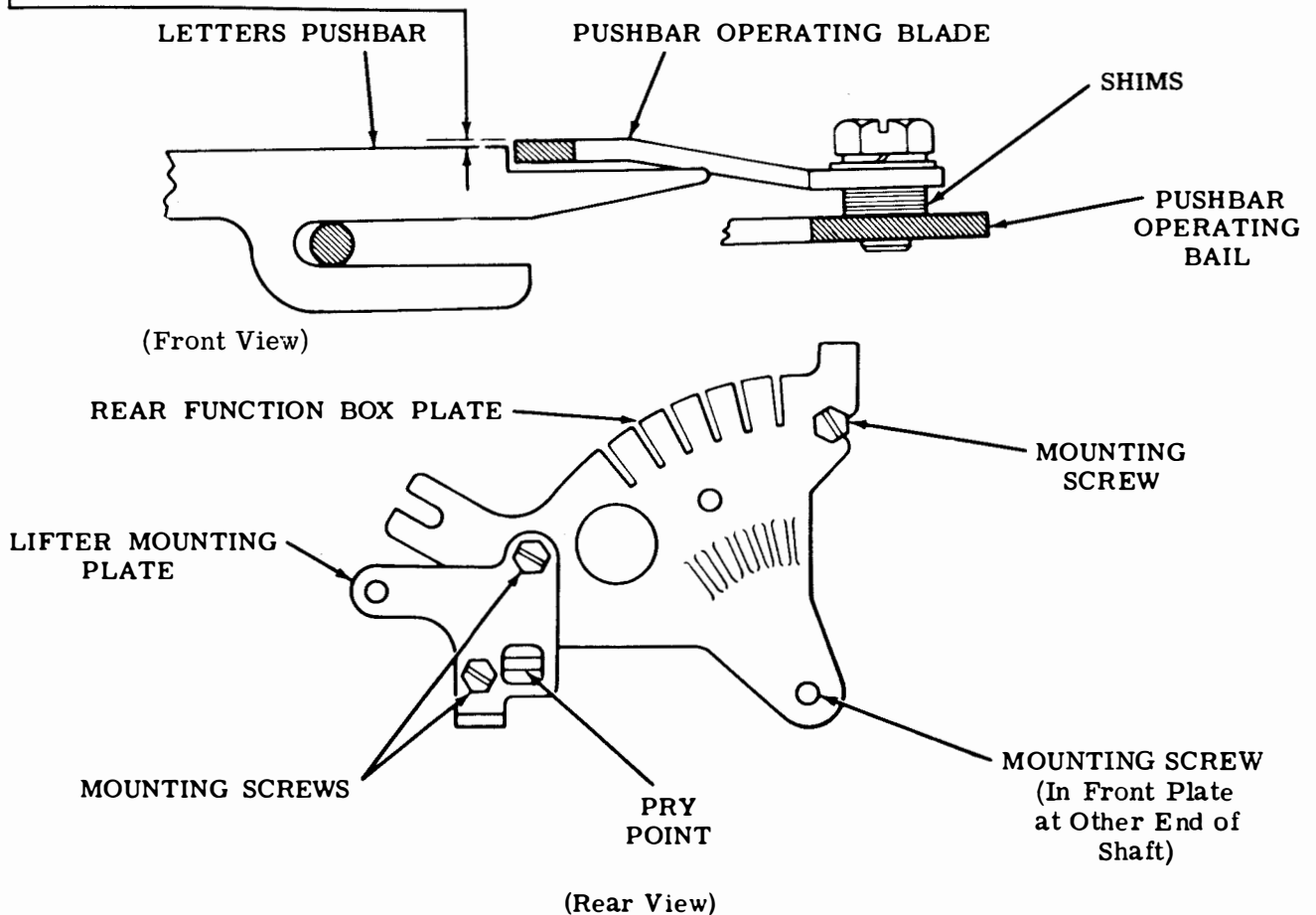

2.49 Typing Mechanism (continued)

PUSHBAR LOCATION

To Check

Manually select the null code combination (all spacing). Rotate selector shaft until function clutch trips.

Requirement

Clearance between the left edge of all bellcrank slots and the left flat of bellcrank stop post for 8-level units should be

Max 0.007 inch*
(preliminary for no. 6 and no. 7 bellcranks)

For 5-level units

Max 0.018 inch
(preliminary for no. 6 and no. 7 bellcranks)
at bellcrank where clearance is maximum when bellcrank with minimum clearance is touching post.

To Adjust

With mounting screws friction tight, pry transfer lever bracket to left until closest bellcrank touches stop post. Tighten mounting screws and check requirement.

CAUTION: BELLCRANK THAT YIELDS MOST SHOULD NOT YIELD MORE THAN 0.007 INCH MEASURED AT POST.

*Removal of function blades will facilitate measuring clearance.

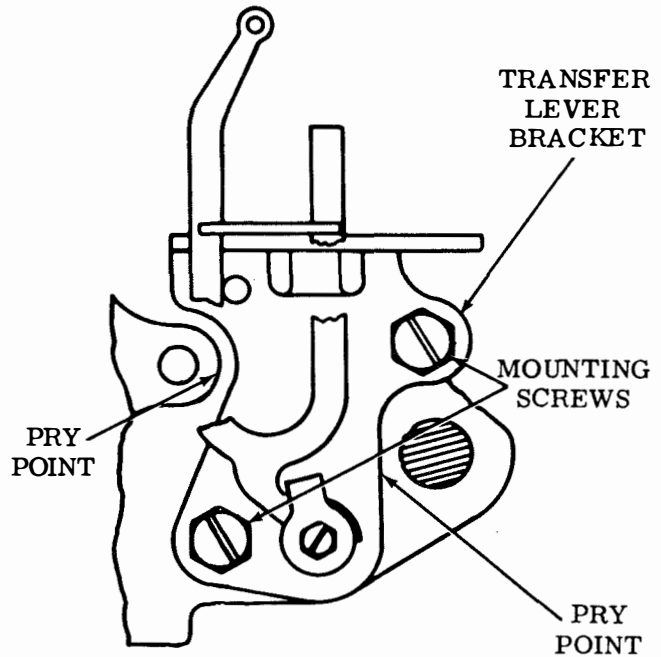

(Top View)

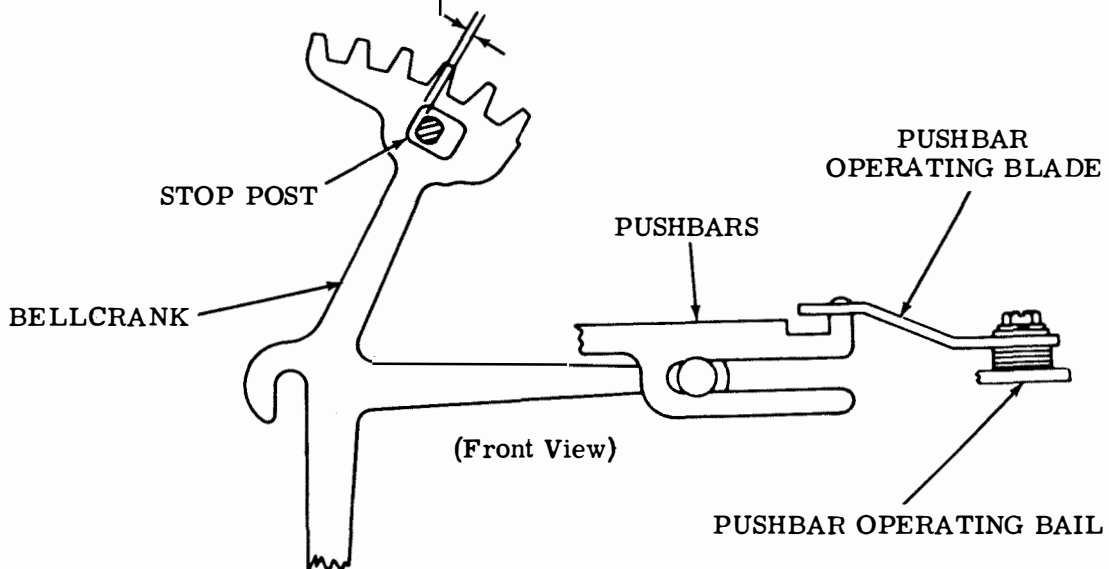

(Front View)

2.50 Ribbon Shift and Print Suppression Mechanism

Note: Refer to variable features (Part 3) for additional adjustments applying to print suppression only.

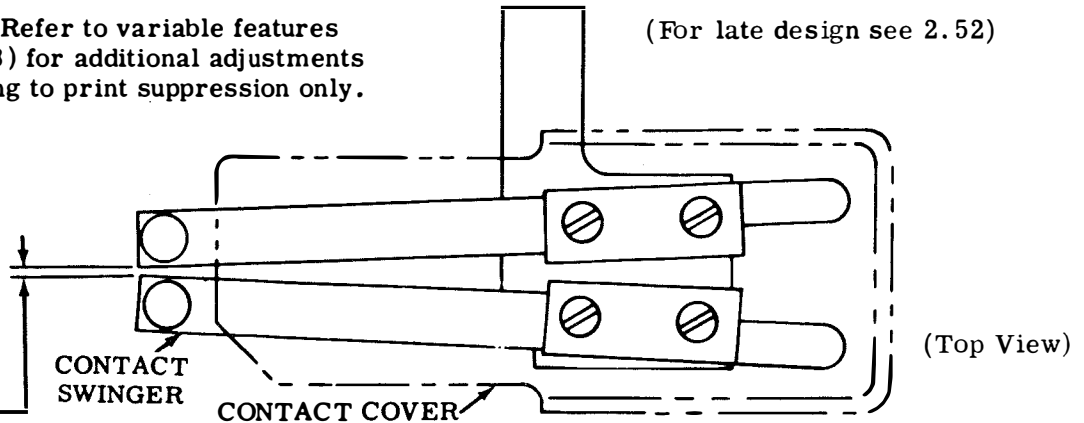

RIBBON SHIFT AND PRINT SUPPRESSION CONTACTS (Early Design)

Note: The contact assembly can be identified by gold-plated contact points with a common transfer contact point on the contact swinger spring.

(1) Requirement

With the two contact swingers positioned toward each other, the clearance between the swingers should be
 Min 0.035 inch---Max 0.060 inch

To Adjust

Disconnect all power from unit. Remove the contact assembly from the function box by removing the two mounting bracket screws. With the four contact cover mounting screws friction tight, position the contact swingers. Check the alignment of the associated contacts with each swinger and tighten the four contact cover mounting screws.

(2) Requirement (Preliminary)

With the contact assembly still removed from the function box, there should be
 Min 0.015 inch---Max 0.020 inch
 clearance between the two swinger contact points and their associated normally open contact points. The top surface of the plastic insulators on both swingers should be parallel to each other and in the same plane (as gauged by eye).

(3) Requirement

In addition to the clearance requirement, it should take
 Min 2 oz---Max 3 oz
 to start each swinger moving and to start normally open contacts moving away from their associated stiffeners.

To Adjust

Adjust the contacts with a contact adjusting tool.

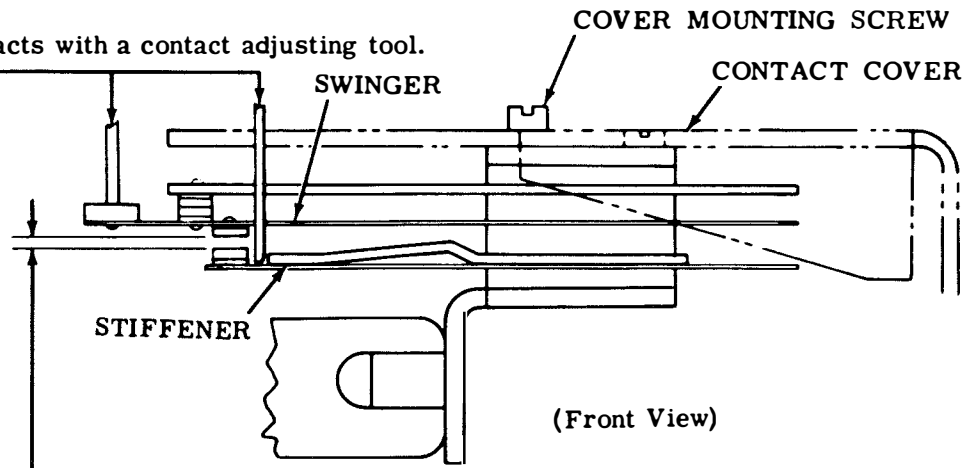

2.51 Ribbon Shift and Print Suppression Mechanism (continued)

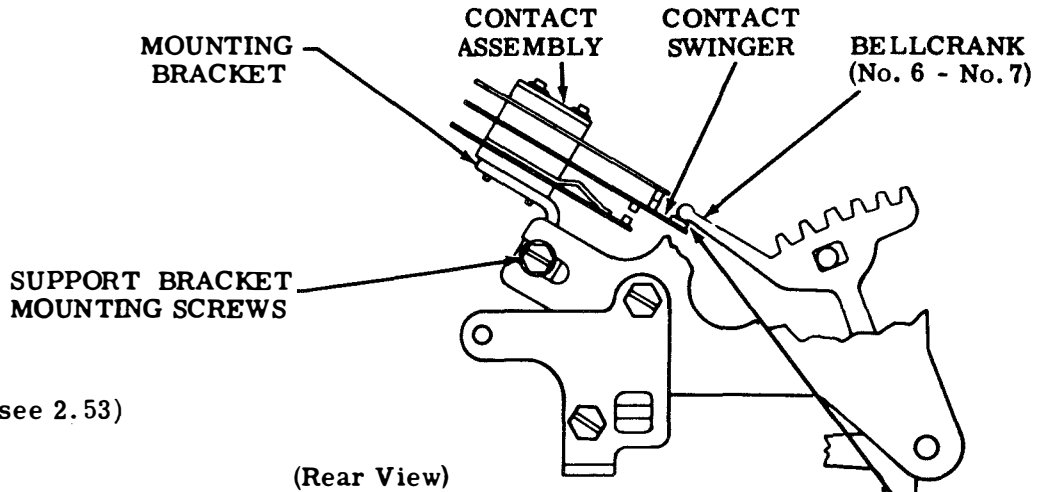

(For late design see 2.53)

RIBBON SHIFT AND PRINT SUPPRESSION
CONTACT POSITION (Early Design)

Note: The following adjustments are to be made with the contact assembly mounted on the unit.

- (1) Requirement
Manually select the null combination. With the function clutch tripped, the follower portion of the no. 6 and no. 7 bellcrank should be centrally positioned with respect to the insulator followers on the contact swingers as viewed from the front of the unit.

To Adjust
With the contact mounting bracket support mounting screws friction tight, position the contact assembly. Tighten screws.

- (2) Requirement
With the null combination still selected and the function clutch tripped
Min some---Max 0.004 inch
clearance between each of the two spacing contacts and their stiffeners. Take up the play in the function box in a clockwise direction (as viewed from the selector side of the unit).

To Adjust
With the contact bracket mounting screws friction tight, position the bracket. Tighten screws.

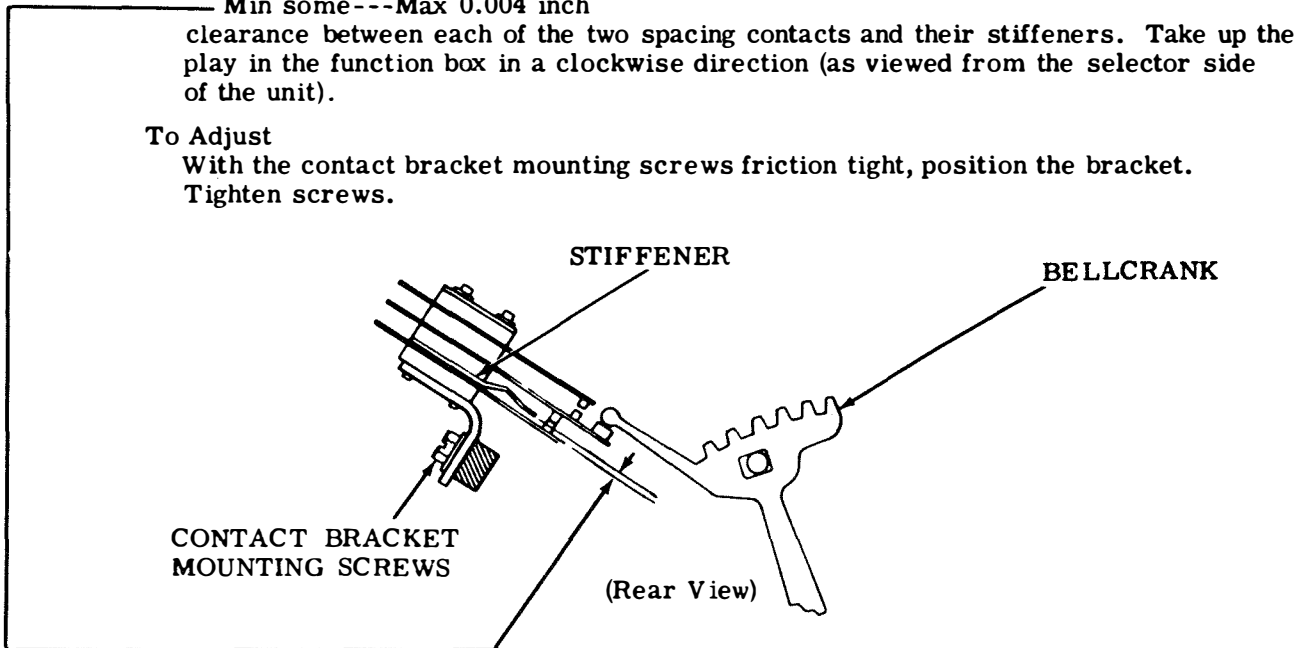

2.52 Ribbon Shift and Print Suppression Mechanism (continued)

Note: Refer to variable features (Part 3) for additional adjustments applying to print suppression only.

(For early design see 2.50)

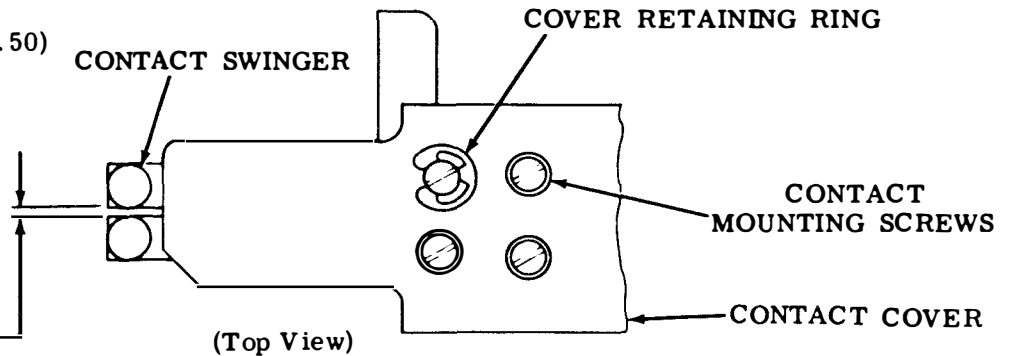

RIBBON SHIFT AND PRINT SUPPRESSION CONTACTS (Late Design)

Note: The contact assembly can be identified by silver contact points with a common transfer contact point on the contact swinger spring and one retaining ring for fastening the cover. The cover may be removed by taking off the cover retaining ring snapped in place over the special mounting screw.

(1) Requirement

With the two contact swingers positioned toward each other, the clearance between the swingers should be

Min 0.035 inch---Max 0.060 inch

To Adjust

Disconnect all power from unit. Remove the contact assembly from the function box by removing the two mounting bracket screws. With the four contact mounting screws friction tight, position the contact swingers. Check the alignment of the associated contacts with each swinger and tighten the four screws.

(2) Requirement (Preliminary)

With the contact assembly still removed from the function box, there should be

Min 0.015 inch---Max 0.020 inch

clearance between the two swinger contact points and their associated normally open contact points. The top surface of the plastic insulators on both swingers should be parallel to each other and in the same plane (as gauged by eye).

(3) Requirement

In addition to the clearance requirement, it should take

Min 45 grams---Max 60 grams

to start each swinger moving and to start normally open contacts moving away from their associated stiffeners.

To Adjust

Adjust the contacts with a contact adjusting tool.

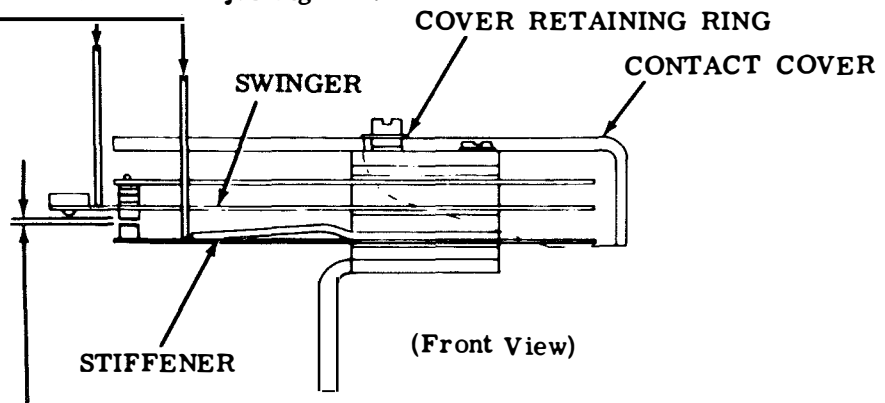

2.53 Ribbon Shift and Print Suppression Mechanism (continued)

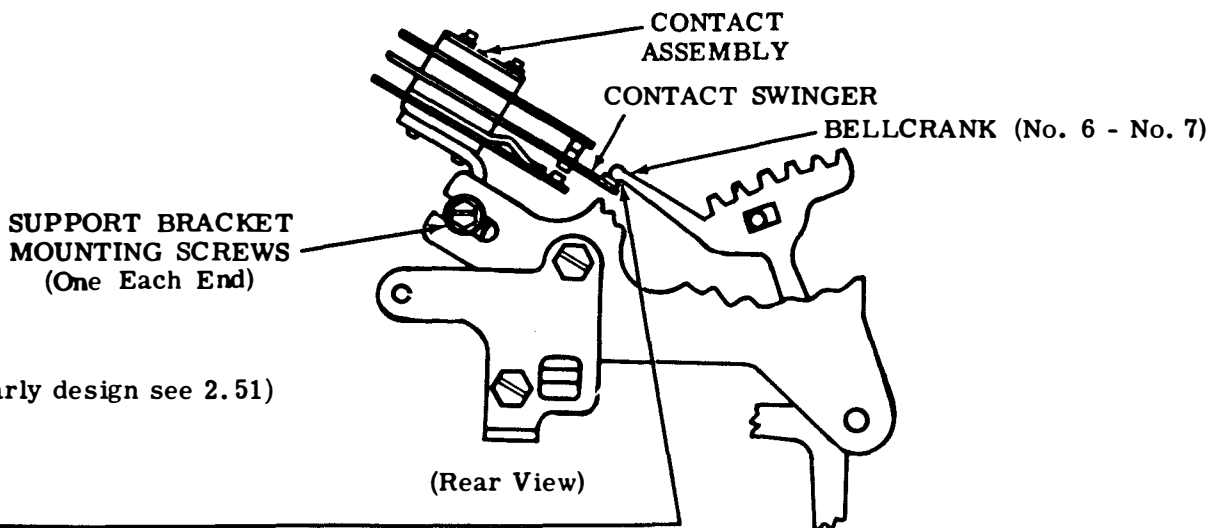

(For early design see 2.51)

RIBBON SHIFT AND PRINT SUPPRESSION CONTACT POSITION (Late Design)

Note: The following adjustments are to be made with the contact assembly mounted on the unit.

(1) Requirement

Manually select the null combination. With the function clutch tripped, the follower portion of the no. 6 and no. 7 bellcranks should be centrally positioned with respect to the insulator followers on the contact swingers as viewed from the front of the unit.

To Adjust

With the contact mounting bracket support mounting screws friction tight, position the contact assembly. Tighten screws.

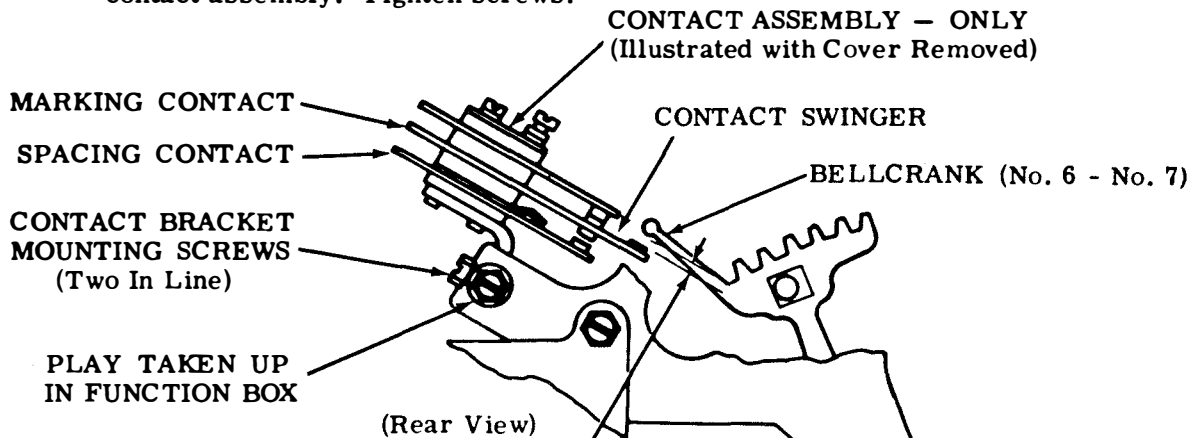

(2) Requirement

With the rubout combination selected and the function clutch tripped, there should be Min 0.025 inch--Max 0.045 inch clearance between the bellcranks and the insulated portion of their respective swingers. Take up the play in the function box.

To Adjust

With the contact bracket mounting screws friction tight, position the bracket. Tighten screws. Replace the cover and secure it with the cover retaining ring.

2.54 Typing Mechanism (continued)

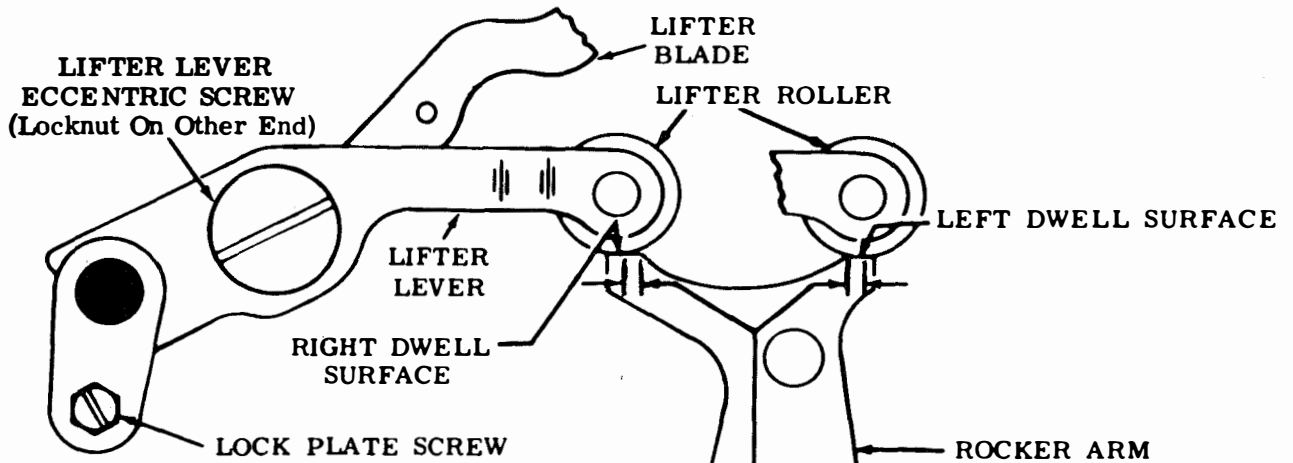

(A) CAM FOLLOWER ROLLER ARM POSITION

To Check

Trip function clutch. Move rocker arm to extreme left position and observe travel of roller on right dwell surface. Move rocker arm to extreme right position and observe travel of roller on left dwell surface.

Requirement

Approximately equal travel on each dwell surface.

To Adjust

Loosen lock plate screw until friction tight. With eccentric screw locknut friction tight, position lifter lever on lifter. Tighten lock plate screw. Do not tighten locknut.

(B) LIFTER OPERATING RANGE (When function blades are used)

Requirement

With function clutch disengaged, clearance between closest projection of bellcranks and associated function blade projection

Min 0.008 inch---Max 0.020 inch

To Adjust

Position lifter lever eccentric screw with locknut loosened. Tighten locknut.

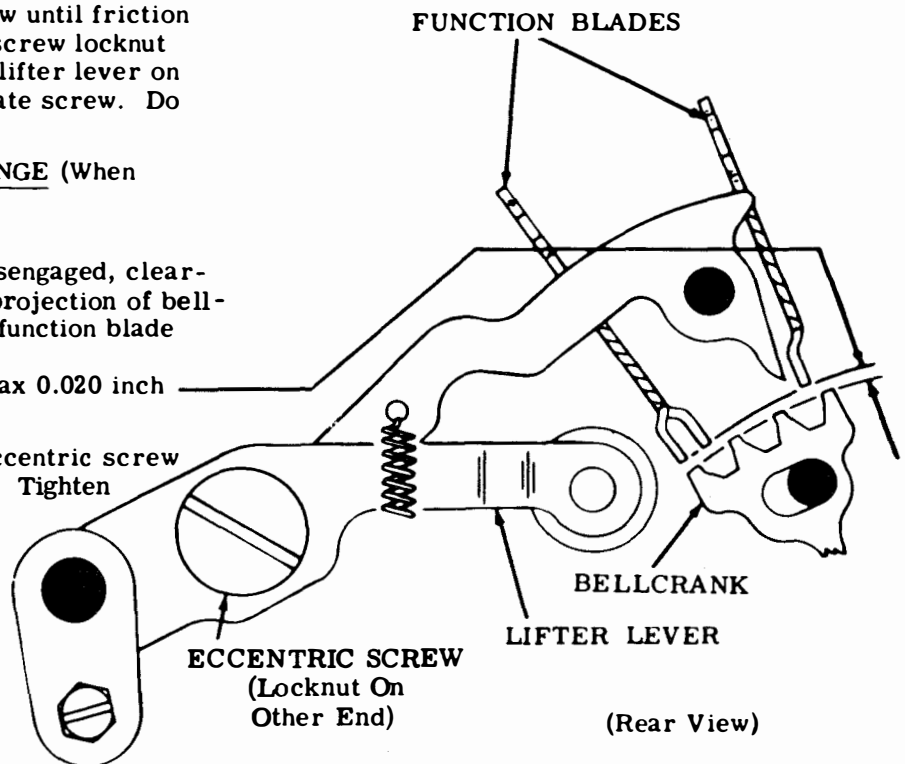

2.55 Typing Mechanism (continued)

Note: Preliminary when no function blades are used.

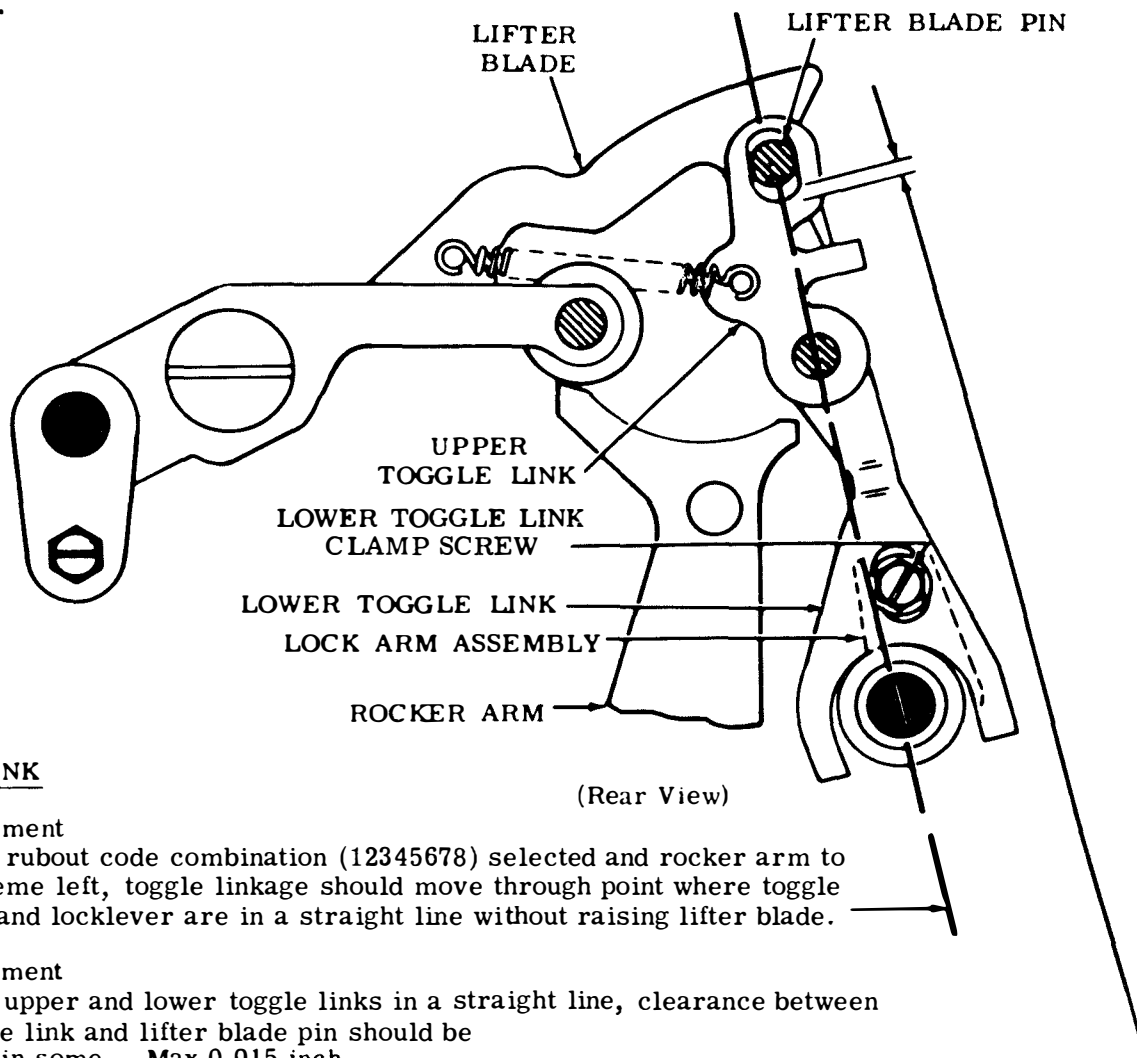

(Rear View)

TOGGLE LINK

- (1) Requirement
With rubout code combination (12345678) selected and rocker arm to extreme left, toggle linkage should move through point where toggle link and locklever are in a straight line without raising lifter blade.
- (2) Requirement
With upper and lower toggle links in a straight line, clearance between toggle link and lifter blade pin should be
Min some---Max 0.015 inch

To Adjust

Position lower toggle link on lock arm assembly with clamp screw friction tight. Rotate retaining ring for access to clearance. Tighten clamp screw.

Note: To avoid interference with the lower toggle link clamp screw, it may be necessary to move high part of correcting drive link eccentric bearing above horizontal center line.

2.56 Typing Mechanism (continued)

Note: Preliminary when no function blades are used.

TOGGLE TRIP ARM

Requirement

As rocker arm approaches extreme right position, the lifter toggle should break and lifter arm roller should drop onto right dwell surface.

To Adjust

By means of pry points, position toggle trip post with clamp screw loosened. Tighten screw.

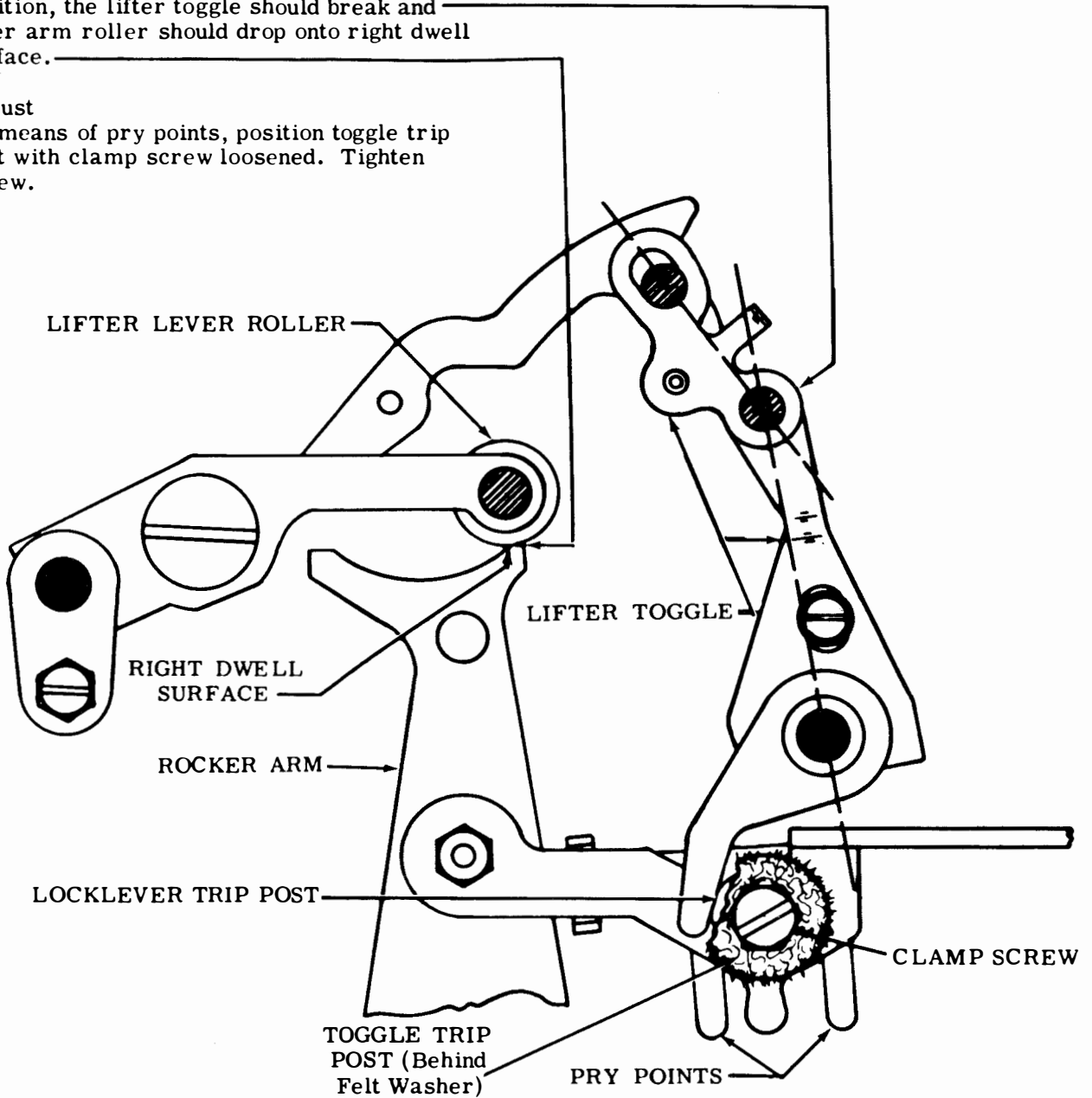

(Rear View)

2.57 Typing Mechanism (continued)

(A) LIFTER TOGGLE LINK SPRING

Requirement

With unit in stop position

Min 1-1/2 oz---Max 2-1/4 oz
to pull spring to installed length.

(B) FUNCTION BLADE SPRING (2 Or More)

Requirement (If so equipped)

With unit in stop position

Min 7 oz---Max 10 oz
to start function blade moving.

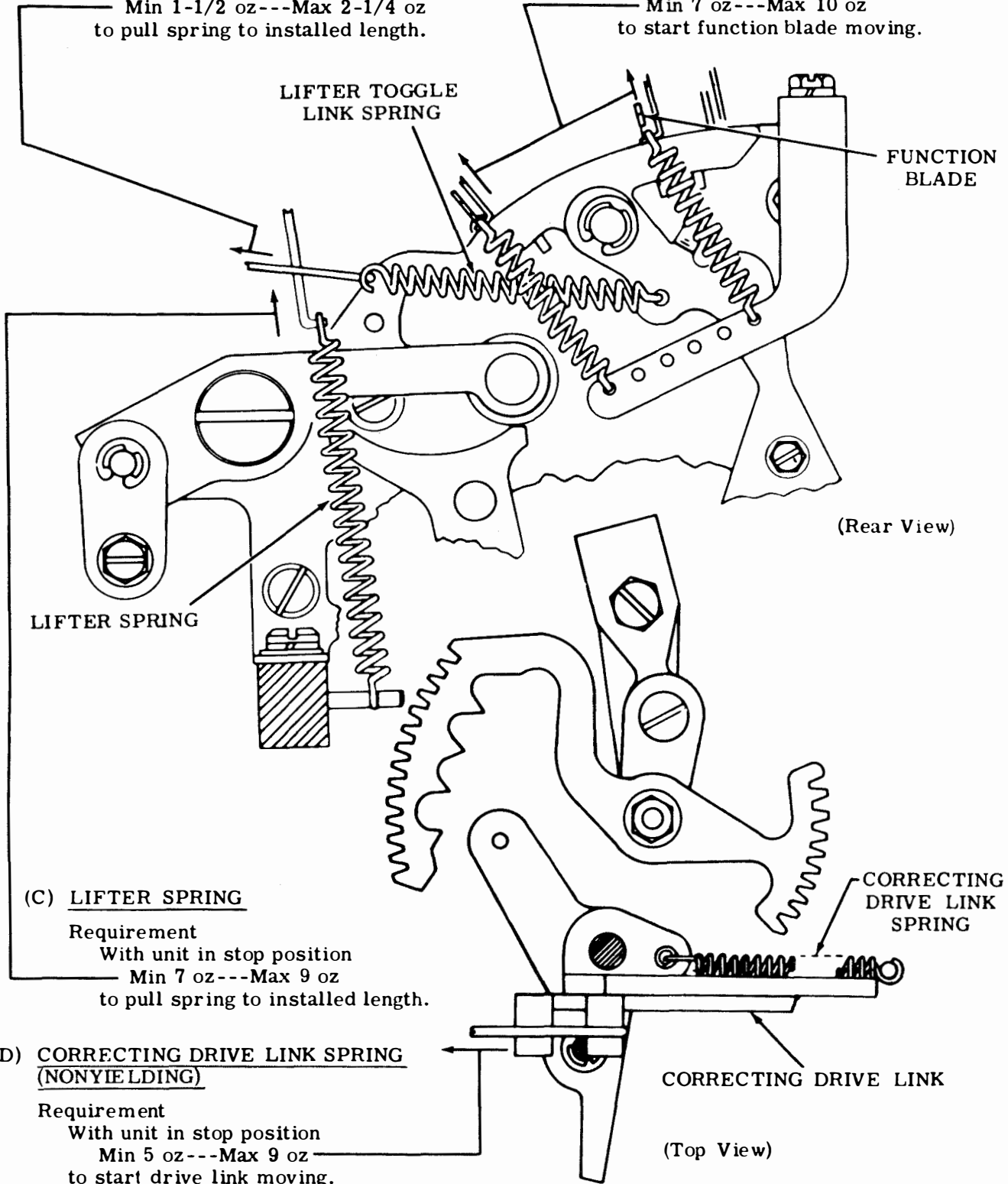

(C) LIFTER SPRING

Requirement

With unit in stop position

Min 7 oz---Max 9 oz
to pull spring to installed length.

(D) CORRECTING DRIVE LINK SPRING (NONYIELDING)

Requirement

With unit in stop position

Min 5 oz---Max 9 oz
to start drive link moving.

2.58 Typing Mechanism (continued)

(A) OSCILLATING BAIL DRIVE LINK**To Check**

Position rocker bail to its extreme left.

Requirement

Sector mounting stud, toggle pivot screw and oscillating bail mounting screw should approximately line up.

To Adjust

With locknut friction tight, position oscillating link by means of its eccentric bushing. Tighten nut.

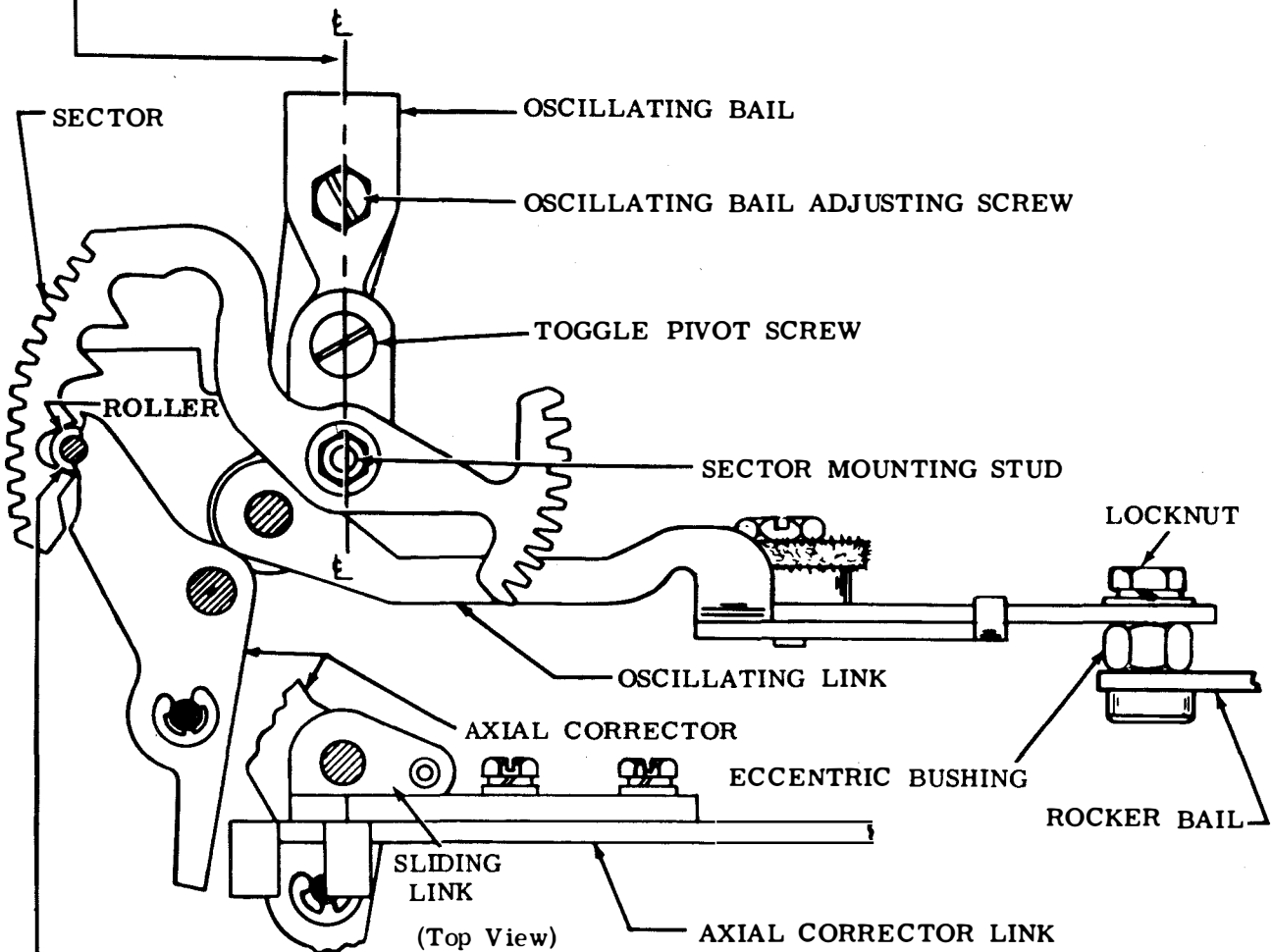
**(B) OSCILLATING BAIL PIVOT****Requirement**

With null combination selected, rotate main shaft taking up the axial play in type wheel shaft toward the front of the unit. The axial corrector roller should enter first notch of the sector centrally.

To Adjust

With oscillating bail adjusting screw friction tight, select null combination. Position oscillating bail by means of its elongated mounting hole so corrector roller enters first notch of the sector when rocker bail moves to its extreme left position. Hold corrector roller firmly in first notch and take up the play in oscillating bail linkage by applying a force to the oscillating bail. Tighten oscillating adjusting screw.

2.59 Typing Mechanism (continued)

CORRECTOR DRIVE LINK (YIELDING) EXTENSION SPRING

Requirement

With the null code combination selected, function clutch tripped, and rocker bail in its extreme left position, place a 32 oz spring scale hook on the end of the corrector axial plate. It should take

Min 16 oz --- Max 32 oz
to move roller from notch in the sector.

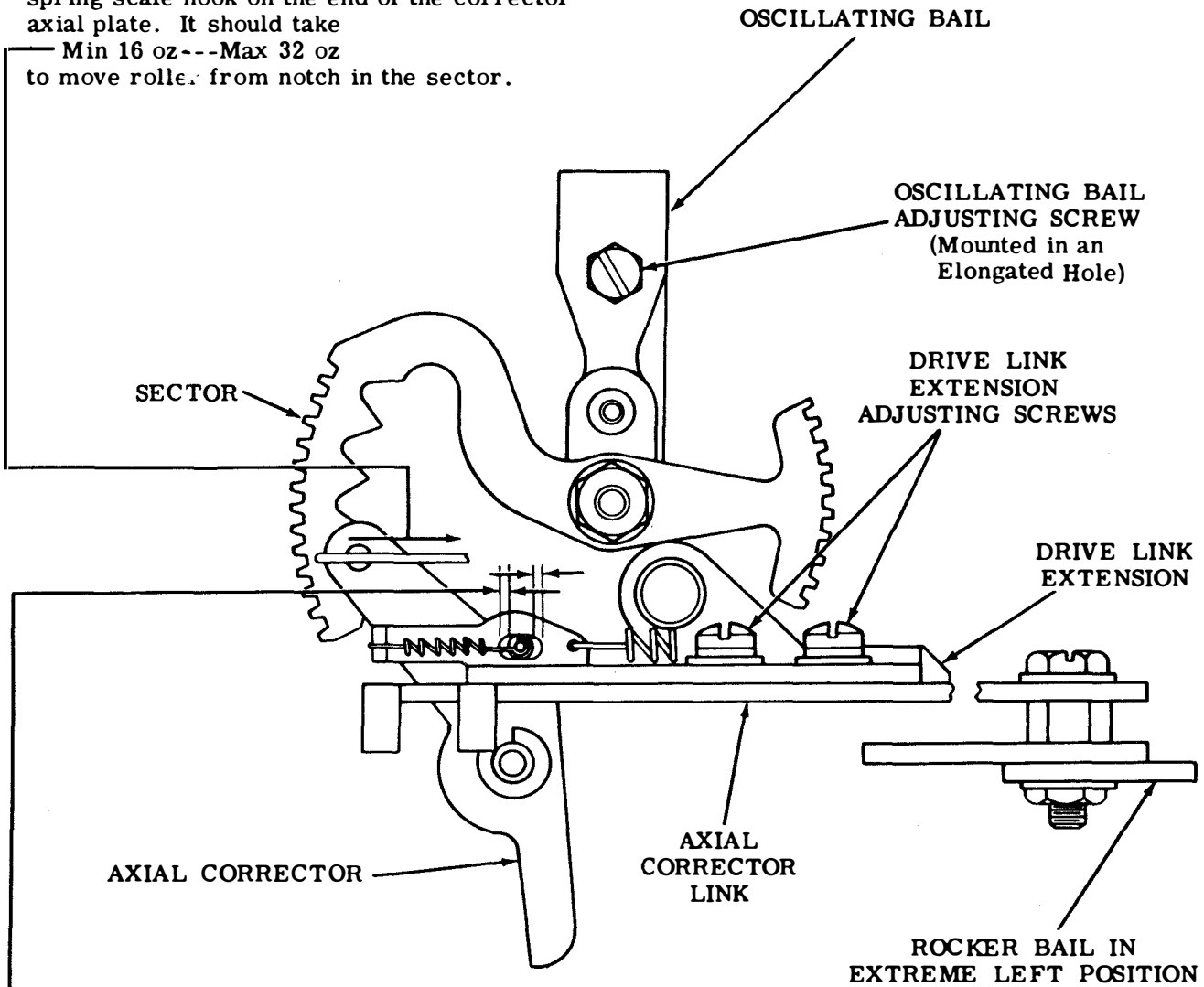

AXIAL CORRECTOR (YIELDING)

Requirement

With all null code combination selected, function clutch tripped and rocker bail in its extreme left position, the axial corrector roller should seat in the first sector notch and there should be

Min 0.005 inch

between the ends of the slot and the spring post. Check both sides and check seating in fourth notch (letters selection). Turn the retaining ring that fastens drive link extension to corrector plate to check the minimum requirement.

To Adjust

Loosen two drive link adjusting screws. Position drive link to meet the requirement and retighten the screws.

2.60 Typing Mechanism (continued)

(A) AXIAL SECTOR ALIGNMENT

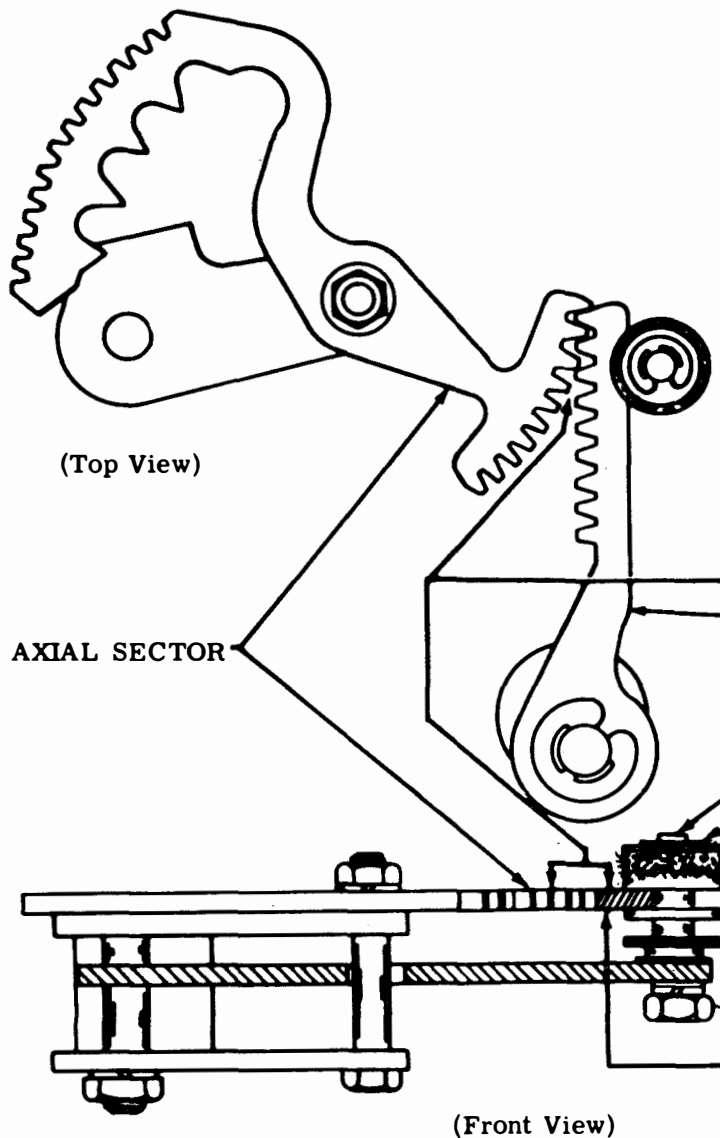

(1) Requirement
Teeth of axial sector and axial output rack should engage by their full thickness.

(2) Requirement
Guide roller free to rotate.

To Adjust
Loosen locknut. Disengage rack. Remove retaining ring and guide roller. Add or remove shims. Place extra shims on top of shim used to retain felt washer. Tighten nut.

Note: On units equipped with larger (0.594 inch diameter) roller, no adjustment is required.

(B) ECCENTRIC SHAFT
DETENT LEVER SPRING (6)

Requirement
Min 7 oz --- Max 10 oz
to start detent lever moving.

Note: Check all 6 springs. There are two on the axial positioning mechanism and four on the rotary positioning mechanism.

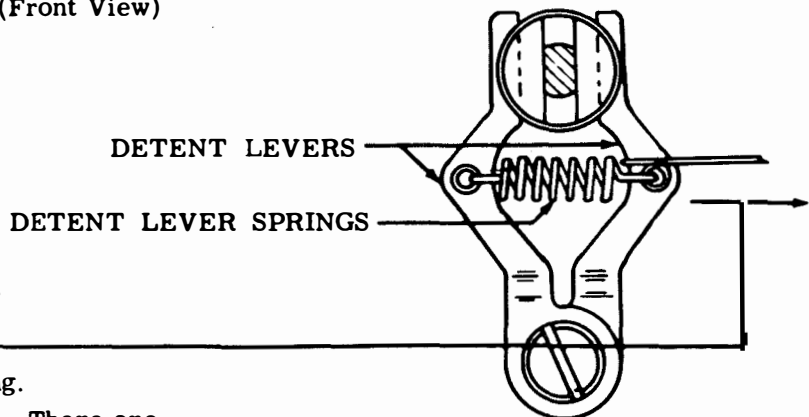

(Top View of Springs on Axial Positioning Mechanism)

2.61 Typing Mechanism (continued)

(A) AXIAL OUTPUT RACK GUIDE ROLLER

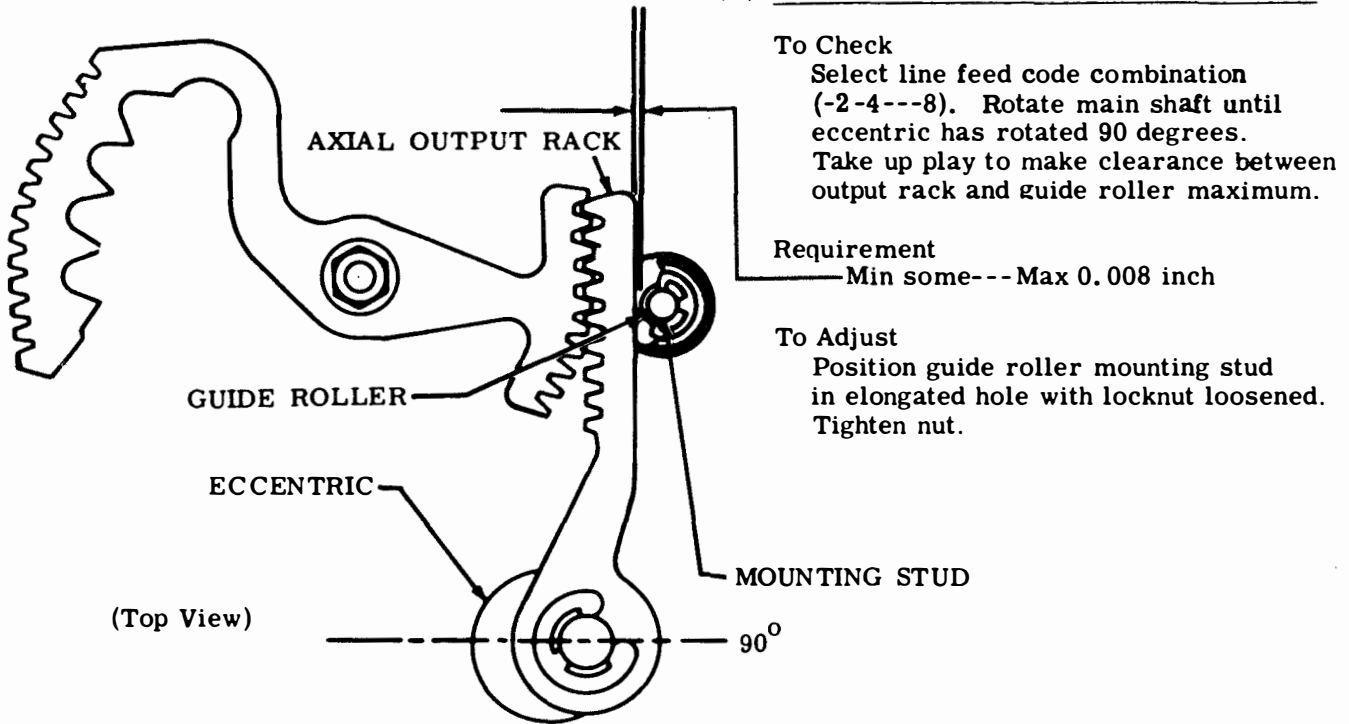

To Check
 Select line feed code combination (-2-4---8). Rotate main shaft until eccentric has rotated 90 degrees. Take up play to make clearance between output rack and guide roller maximum.

Requirement
 Min some---Max 0.008 inch

To Adjust
 Position guide roller mounting stud in elongated hole with locknut loosened. Tighten nut.

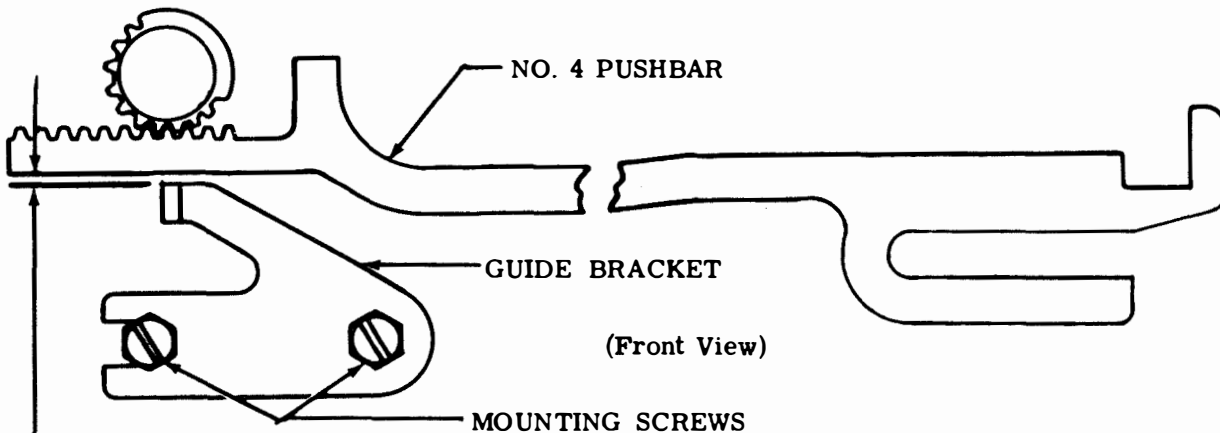

(B) PUSHBAR GUIDE BRACKET

To Check
 Manually select carriage return code combination (1-34---8). Rotate main shaft so that no. 4 pushbar moves through complete range of travel.

Requirement
 When play is taken up to make clearance maximum
 Min some---Max 0.008 inch
 between no. 4 pushbar and guide bracket throughout complete travel of bar.

To Adjust
 Position guide bracket with mounting screws loosened. Tighten screws.

2.62 Typing Mechanism (continued)

(A) CORRECTING DRIVE LINK (NONYIELDING)

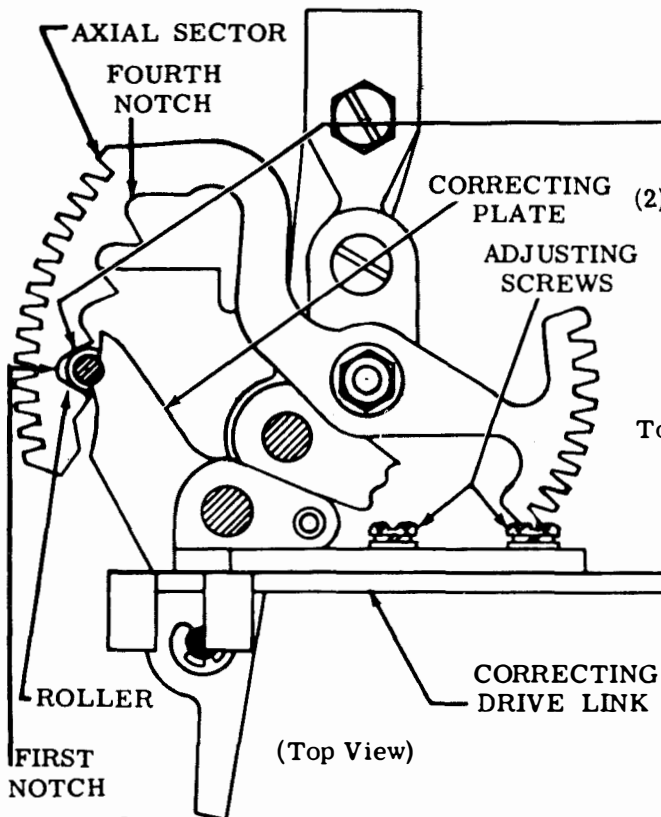

(1) To Check

Select the null code combination. Trip function clutch and move rocker bail to extreme left.

Requirement

Roller on axial correcting plate firmly seated in first notch of axial sector.

(2) To Check

Select rubout code combination (12345678). Trip function clutch and move rocker bail to extreme left.

Requirement

Roller on axial correcting plate firmly seated in fourth notch of axial sector.

To Adjust

Loosen drive link adjusting screws. Holding roller firmly seated in first notch and holding drive link down (bottomed) against bushing, tighten adjusting screws.

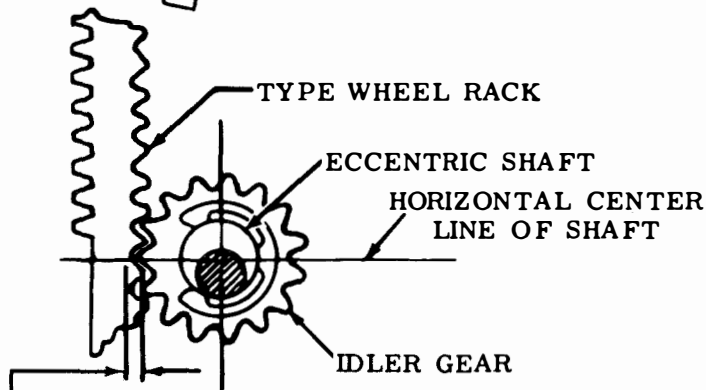
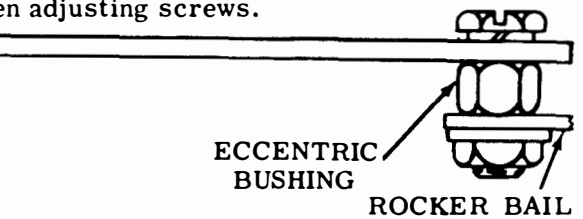

(B) TYPE WHEEL RACK CLEARANCE

Requirement

With function clutch disengaged and upper no. 7 pushbar to the right
 Min some---Max 0.015 inch
 clearance between idler gear and rack at the closest point when all
 play is taken up in a direction to make clearance a maximum.
 There should be some clearance throughout travel of the rack.

To Adjust

With mounting screw friction tight, position idler gear eccentric
 shaft by means of three adjusting holes in top of shaft. Tighten
 screw.

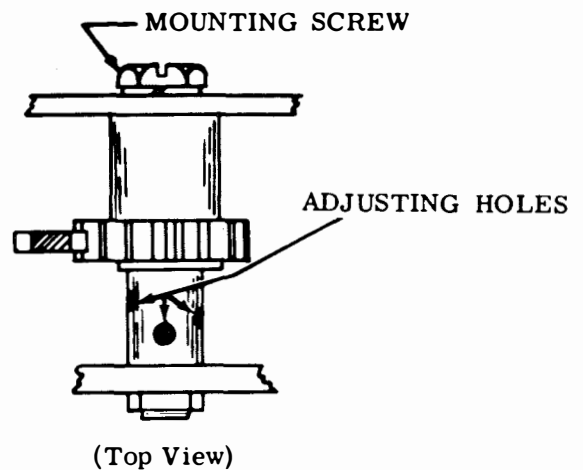

2.63 Typing Mechanism (continued)

ROTARY CORRECTOR MESH**Requirement**

With clamp arm friction tight and X combination selected, the second tooth from the top of the rotary output rack (with the pushbars manually detented) should seat between the lobes of the rotary corrector arm.

To Adjust

Loosen clamp arm screw and eccentric bushing locknut. With the pivot of the corrector arm to the right of the center of the bushing, position the rotary corrector arm. Tighten the bushing locknut. Do not tighten clamp arm screw at this point.

To Check

Check engagement in a similar manner as in requirement above with the fifth tooth (no. 3, 4, and 7 pulse marking), ninth tooth (no. 4 pulse marking), and sixteenth tooth (no. 3 and 5 pulse marking). Refine the adjustment if necessary.

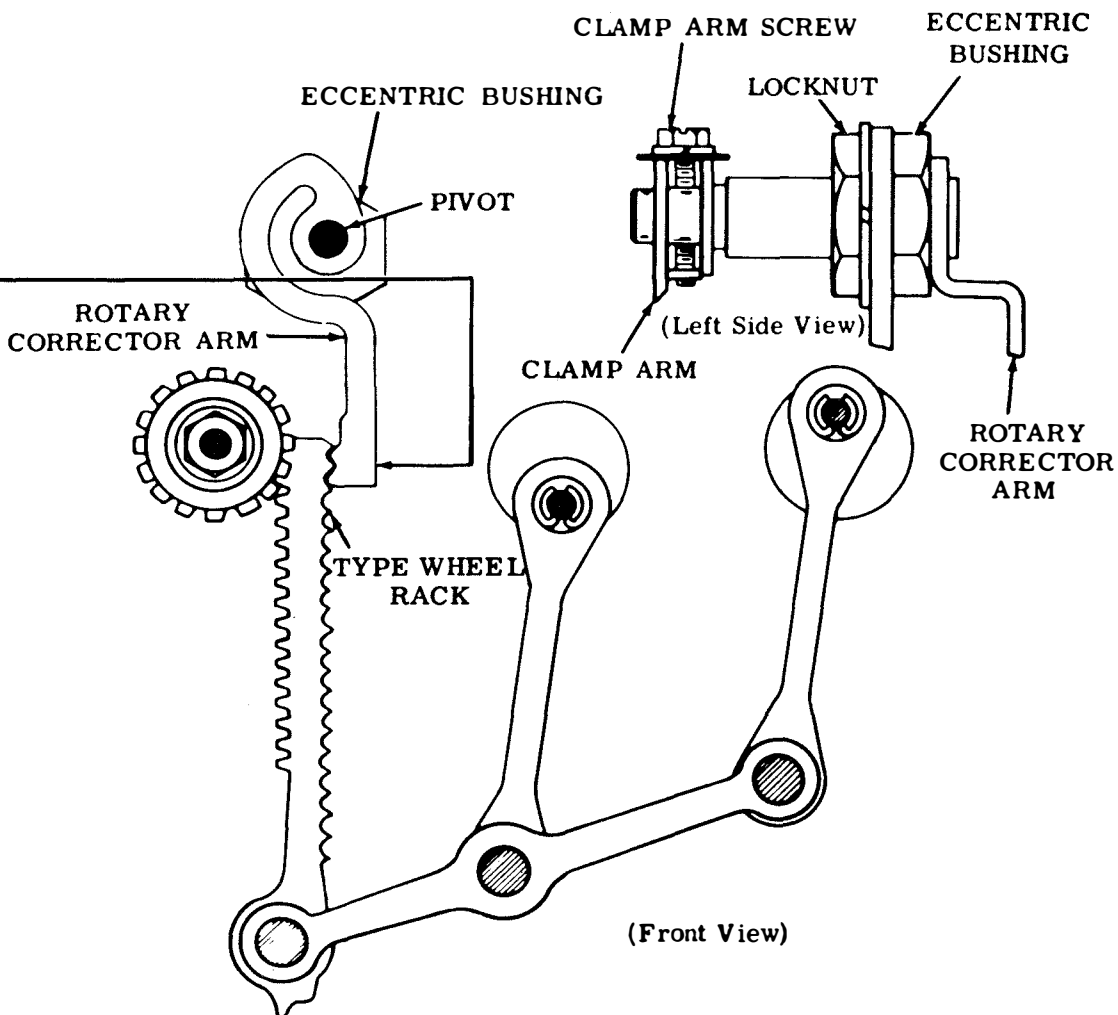

2.64 Typing Mechanism (continued)

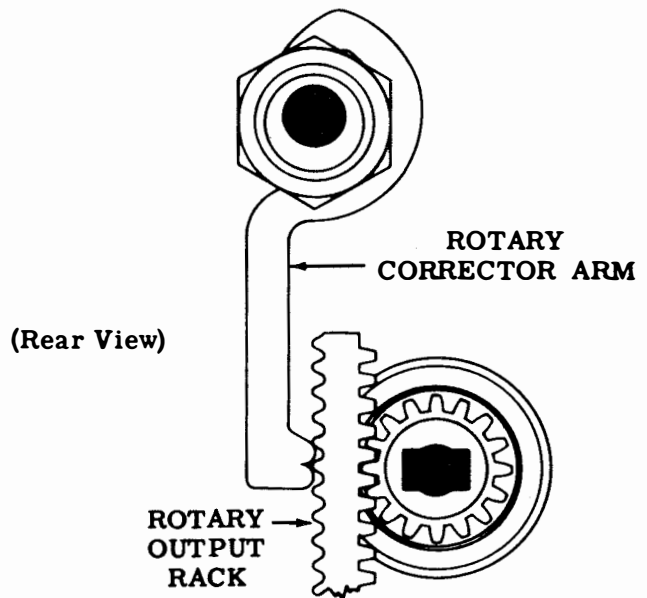
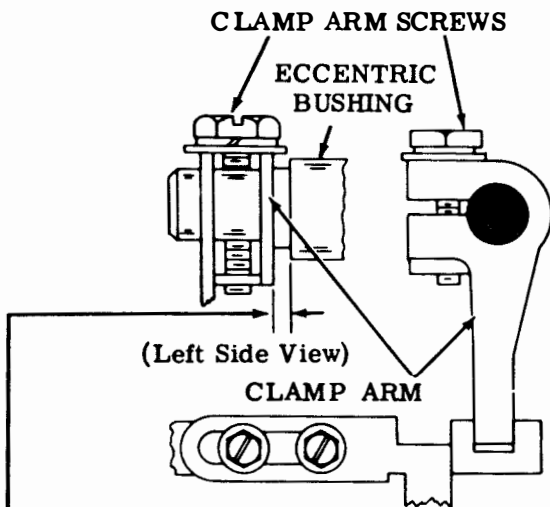

ROTARY CORRECTOR ARM

To Check

With unit in letters condition, select the rubout code combination (12345678). Position rocker bail to extreme left. Manually seat corrector arm in rack.

Requirement

The rotary corrector arm should seat firmly in the rotary output rack.
 Min some---Max 0.006 inch endplay between clamp arm and bushing, with unit in the stop position.

To Adjust (Units equipped with a yielding axial corrector)

As the rocker bail approaches the extreme left and the spring post of the axial corrector starts to leave the end of its slot, take up play of drive arm in its operating fork towards main bail and position the rotary corrector arm finger tight against rotary output rack and tighten clamp arm screw.

To Adjust (Units equipped with nonyielding axial corrector)

As the rocker bail approaches the extreme left, measure clearance between the axial corrector roller and the sector notch.
 When clearance is
 Min some---Max 0.005 inch
 position rotary corrector arm finger tight against rotary output rack, and tighten correcting clamp arm screw.

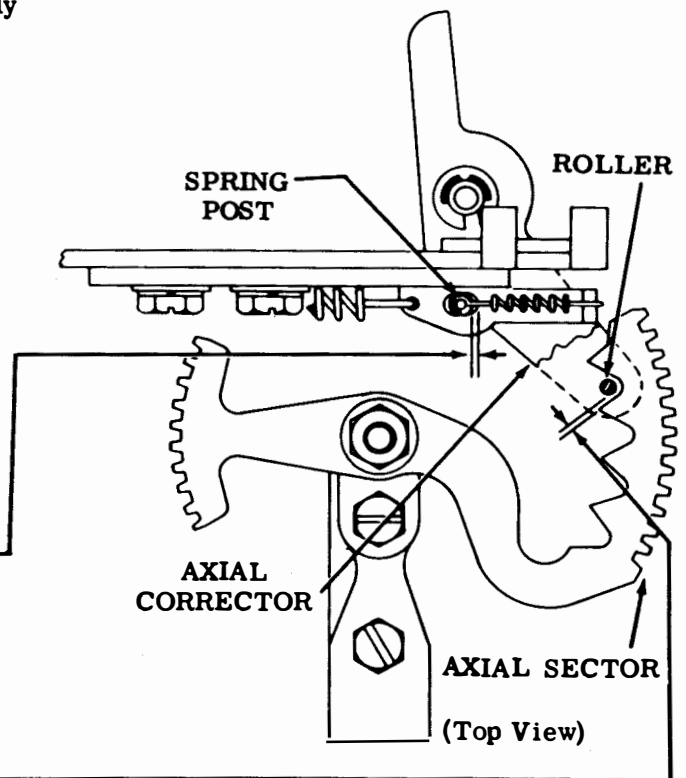

2.65 Ribbon Shift and Print Suppression Mechanism (continued)

RIBBON CARRIER SPRING (Late Design)

Requirement

With unit in stop position
Min 7 oz---Max 10 oz
to start carrier moving.

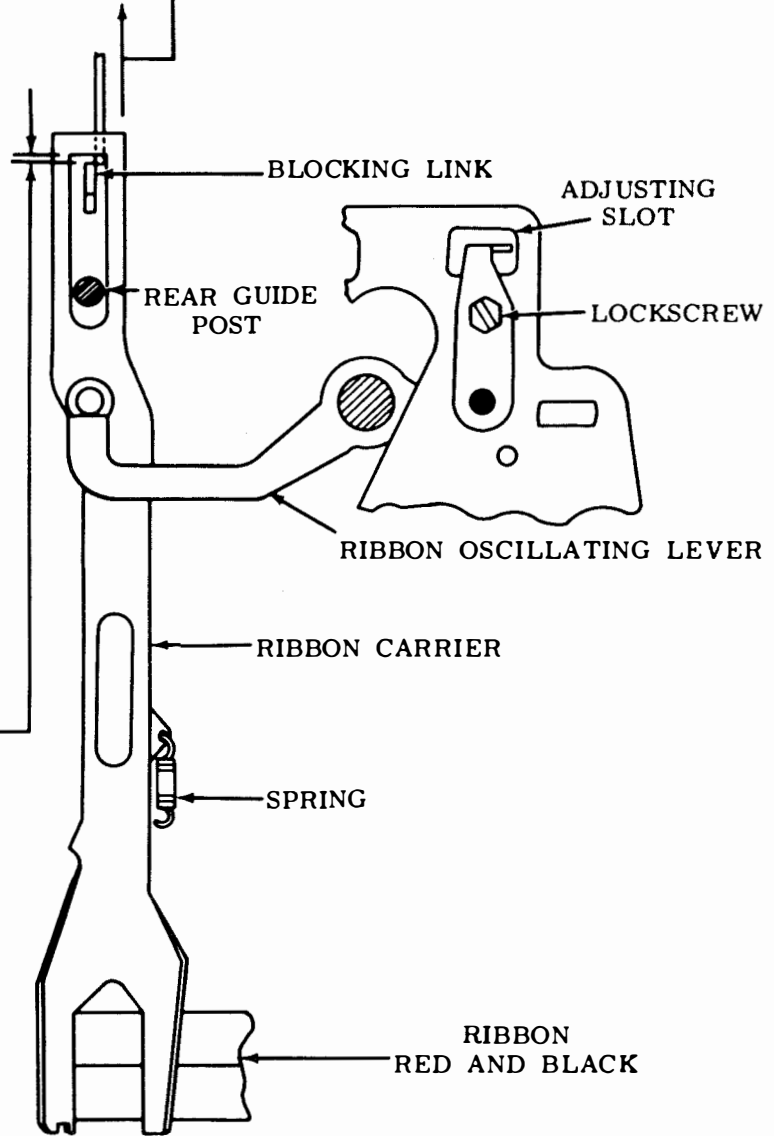

RIBBON CARRIER (Late Design)

Requirement

With function clutch disengaged,
manually lift blocking lever so
that it is opposite ribbon carrier
and against the type wheel shaft
housing.

Min 0.040 inch---Max 0.060 inch
clearance between blocking link
and ribbon carrier.

To Adjust

Loosen lock screw. Position ribbon
oscillating lever, using adjusting
slot. Tighten screw.

2.66 Ribbon Shift and Print Suppression Mechanism (continued)

Note: The following adjustments apply to units with graphics either suppressed or in red (red of red-black ribbon towards rear of unit) when magnet is de-energized.

(B) ARMATURE AIR GAP (Early Design)**Requirement**

With armature on downstop screw
 Min 0.015 inch---Max 0.020 inch
 clearance between magnet core
 and armature at closest point and
 Min some---Max 1/32 inch
 clearance between rear of armature
 slot and blocking link as gauged by
 eye.

To Adjust

Position magnet bracket with screws
 loosened. Tighten screws. Check for
 binds.

(A) ARMATURE DOWNSTOP (Early Design)**Requirement**

With rocker bail in extreme left position
 and ribbon carrier biased downward,
 hold the blocking link against the type
 wheel shaft housing.

Min some---Max 0.005 inch
 clearance between top surface of blocking
 link and lower surface of ribbon
 carrier.

To Adjust

Position armature downstop screw with
 locknut loosened.

(D) ARMATURE SPRING (Early Design)**Requirement**

With spring disconnected
 Min 3-1/2 oz---Max 4-1/2 oz
 when pulled to installed length.

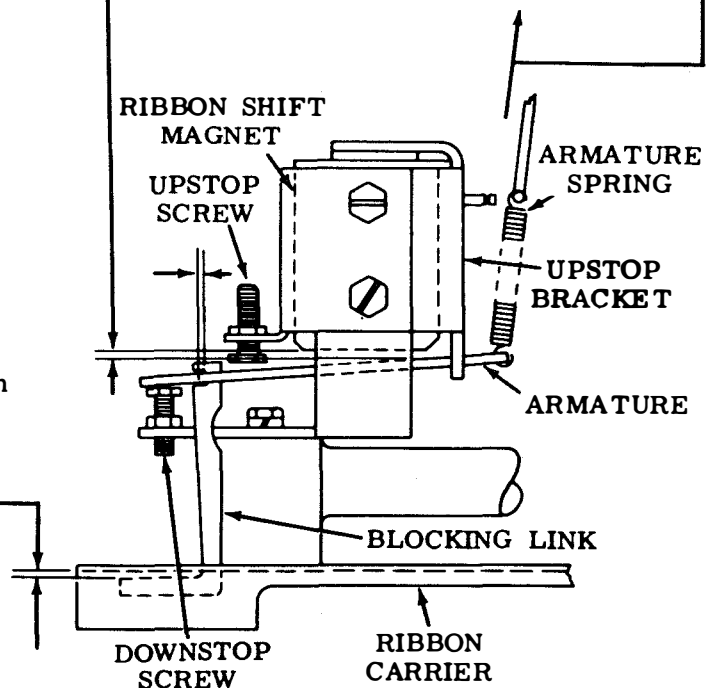
(C) ARMATURE UPSTOP (Early Design)**Requirement**

With armature held against
 upstop screw (magnet is not
 to be energized)

Min 0.004 inch---Max 0.007 inch
 clearance between magnet core
 and armature at closest point.

To Adjust

Position upstop screw with lock-
 nut loosened. Tighten nut.

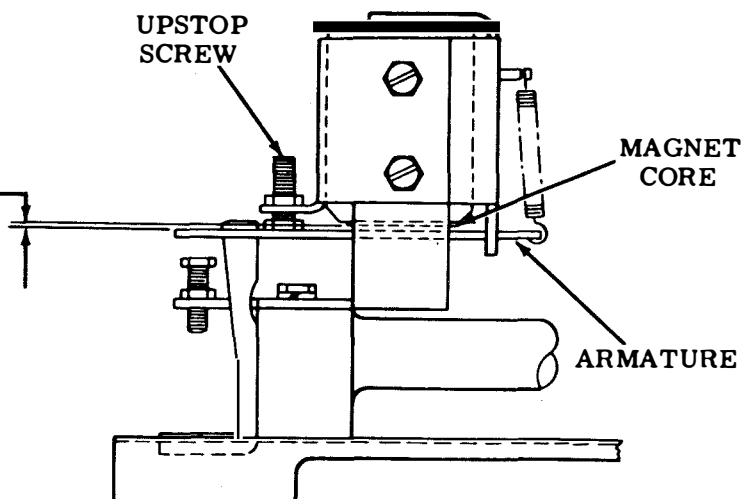

Note: Refer to Part 3 for additional print suppression adjustments.

2.67 Ribbon Shift and Print Suppression Mechanism (continued)

Note: The following adjustments apply to units with printing of graphics either suppressed or in red (red of red-black ribbon towards front of unit) when magnet is de-energized.

(C) ARMATURE AIR GAP AND DOWNSTOP
(Late Design)

Requirement

With armature resting on downstop screw
Min 0.015 inch---Max 0.020 inch
clearance between magnet core and
armature at closest point.

To Adjust

Position downstop screw with locknut
loosened. Tighten nut.

(B) BLOCKING LINK (Late Design)

Requirement

With armature held against upstop screw
(magnet is not to be energized) and rib-
bon carrier biased upward

Min some---Max 0.008 inch
clearance between blocking link lower
surface and ribbon carrier top surface
at closest point and

Min some---Max 0.031 inch
clearance between rear of armature
slot and blocking link as gauged by eye.

To Adjust

Position magnet bracket with screws
loosened. Tighten screws.

(A) ARMATURE UPSTOP (Late Design)

Requirement

With armature held against upstop
screw (magnet is not to be energized)
ribbon carrier biased upward

Min 0.005 inch---Max 0.010 inch
clearance between magnet core and
armature at closest point.

To Adjust

Position upstop screw with locknut
loosened. Tighten nut.

(D) ARMATURE SPRING (Late Design)

Requirement

With spring disconnected
Min 3-1/2 oz---Max 4-1/2 oz
when pulled to installed length.

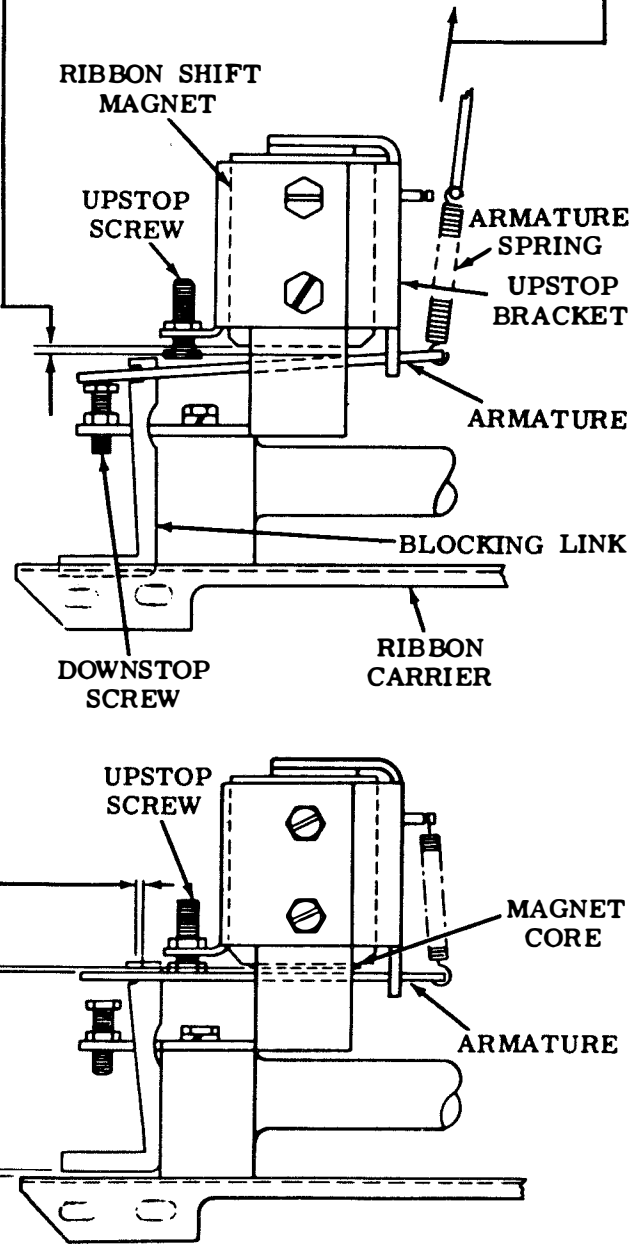

Note: Refer to Part 3 for additional print suppression adjustments.

2.68 Typing Mechanism (continued)

PRINTING LATCH

Note 1: For units with adjustable printing latch mounting bracket.

(1) Requirement

With rocker bail in its extreme left position, manually raise the print hammer accelerator. The clearance between the print hammer accelerator and the printing latch should be

Min some---Max 0.015 inch

(2) Requirement

With rocker bail in its extreme right position, there should be some over-travel of the print hammer accelerator with respect to the latching surface of the printing latch and some clearance between the print hammer accelerator and the ribbon carrier (or accelerator blocking link if present).

To Adjust

- (1) Position the rocker bail to the extreme right. With the high part of the eccentric to the left, rotate the eccentric so that the clearance between the print hammer accelerator and the ribbon carrier is approximately 0.065 inch. With mounting screws friction tight, position the printing latch mounting bracket to its extreme rear position.
- (2) With the rocker bail to the extreme left, move the printing latch mounting bracket toward the front until the print hammer accelerator just trips. Tighten the mounting screws.
- (3) With the rocker bail to the extreme left, position the trip lever eccentric (keeping the high part to the left) until the clearance between the printing latch and the print hammer accelerator is as called for in requirement (1). Tighten nut.

Note 2: For units with non-adjustable printing latch mounting bracket use above "(1) Requirement" and adjust according to "To Adjust (3)."

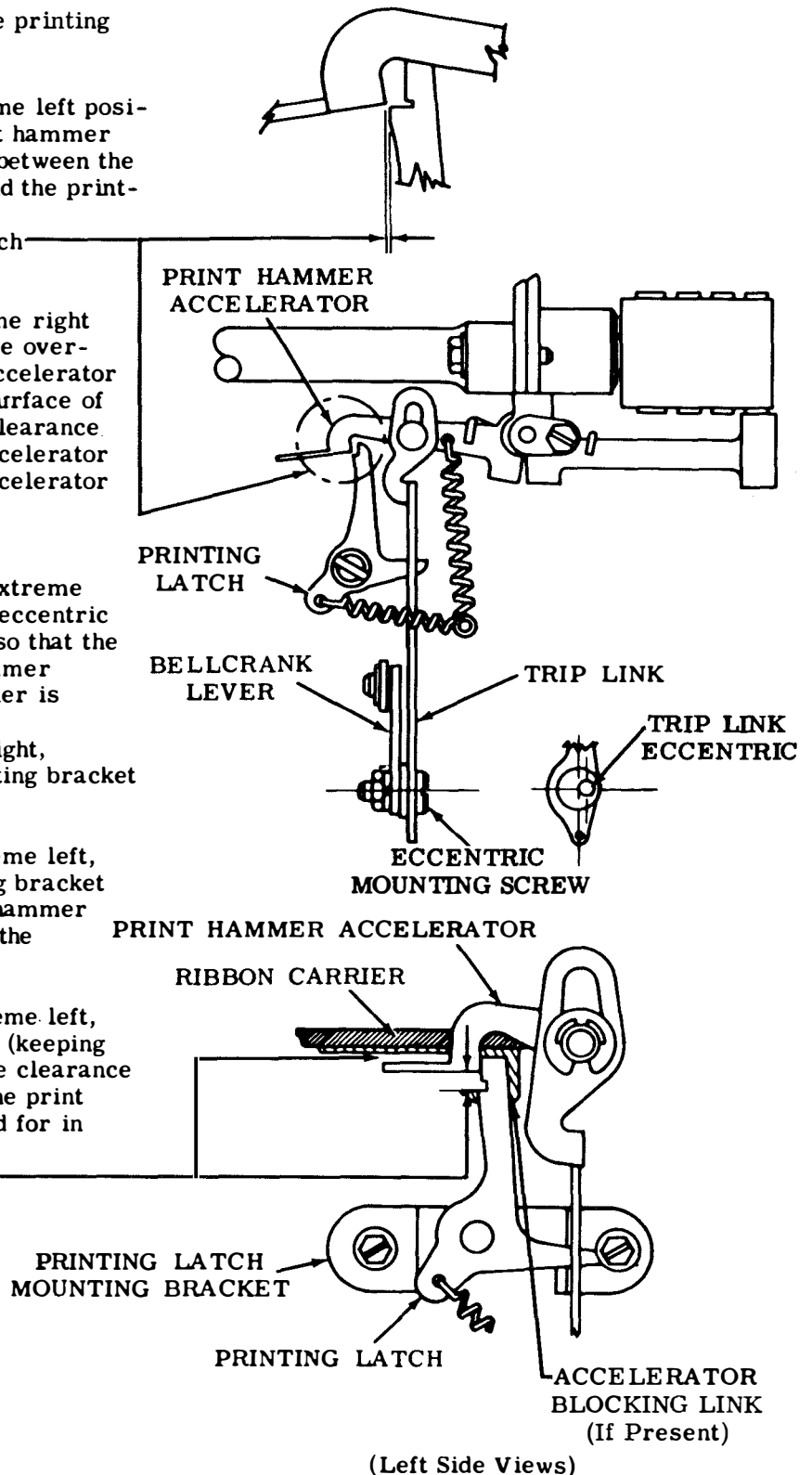

(Left Side Views)

2.69 Typing Mechanism (continued)

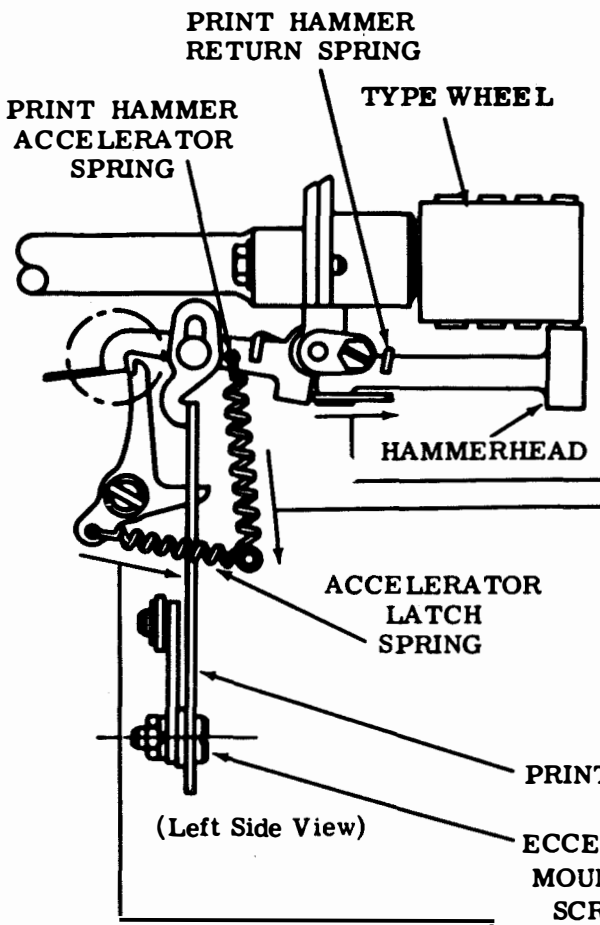

PRINT HAMMER RETURN SPRING

Requirement

With unit in the stop position, it should require
Min 1 oz---Max 3 oz
to pull the print hammer lever so that the top
of the hammerhead is level with the type wheel.

PRINT HAMMER ACCELERATOR SPRING

Requirement

With the unit in the stop position
Min 32 oz---Max 42 oz
to pull the spring to its installed length.

ACCELERATOR LATCH SPRING

Requirement

With the unit in the stop position
Min 5 oz---Max 7 oz
to pull the spring to its installed length.

PRINT HAMMER TRIP LEVER SPRING

Requirement

Min 4 oz---Max 7 oz
to pull spring to installed length.

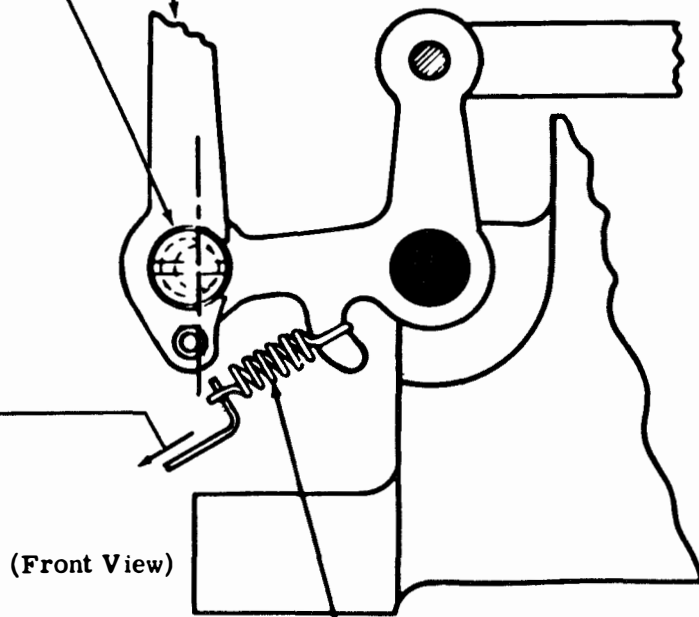

PRINTING TRIP LEVER SPRING

2.70 Typing Mechanism (continued)

PRINT HAMMER

To Check

With nut operating under power.

Requirement

Print hammer aligned with type wheel so as to obtain quality printing with some clearance between the rim on the feed wheel and the side of the print hammer.

To Adjust

Position print hammer shaft with its locknut friction tight. Tighten locknut.

Note: It may be necessary to make the TYPE WHEEL (Final) (2.71) adjustment and then refine this adjustment.

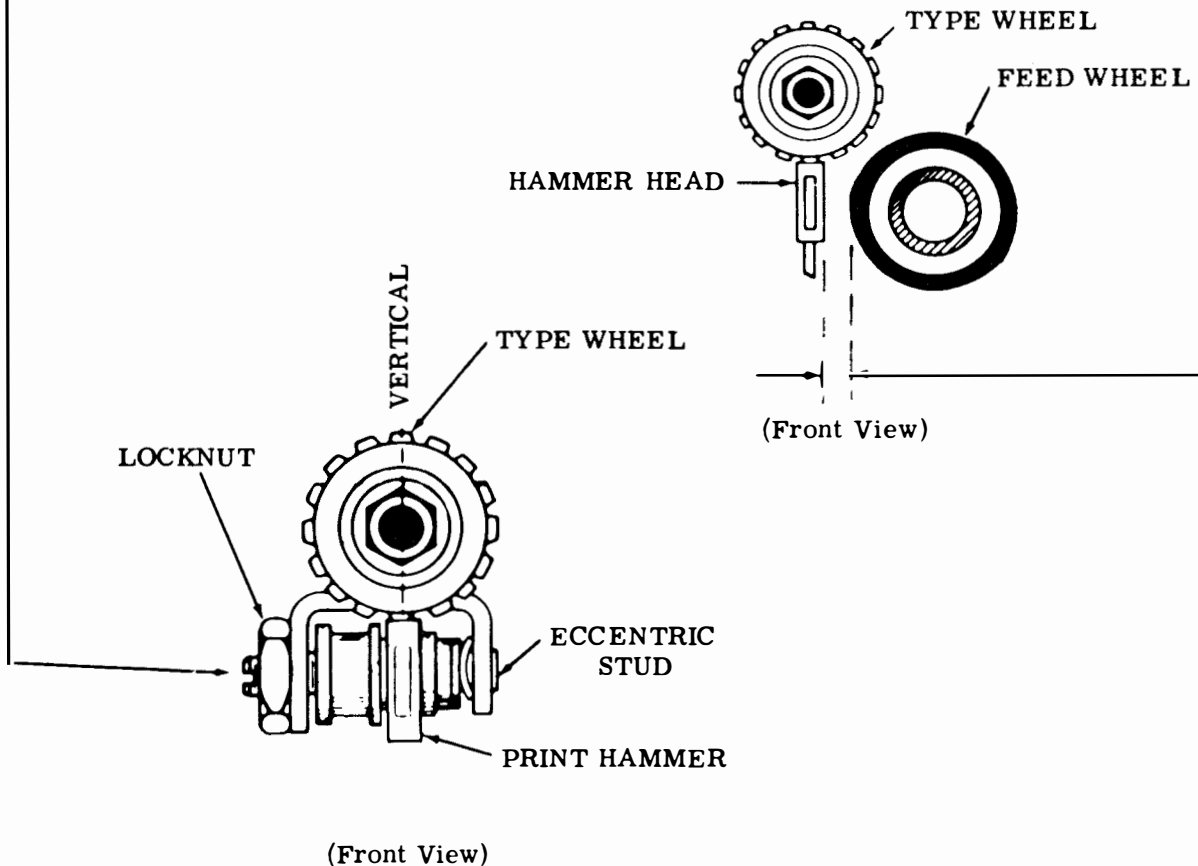

2.71 Typing Mechanism (continued)

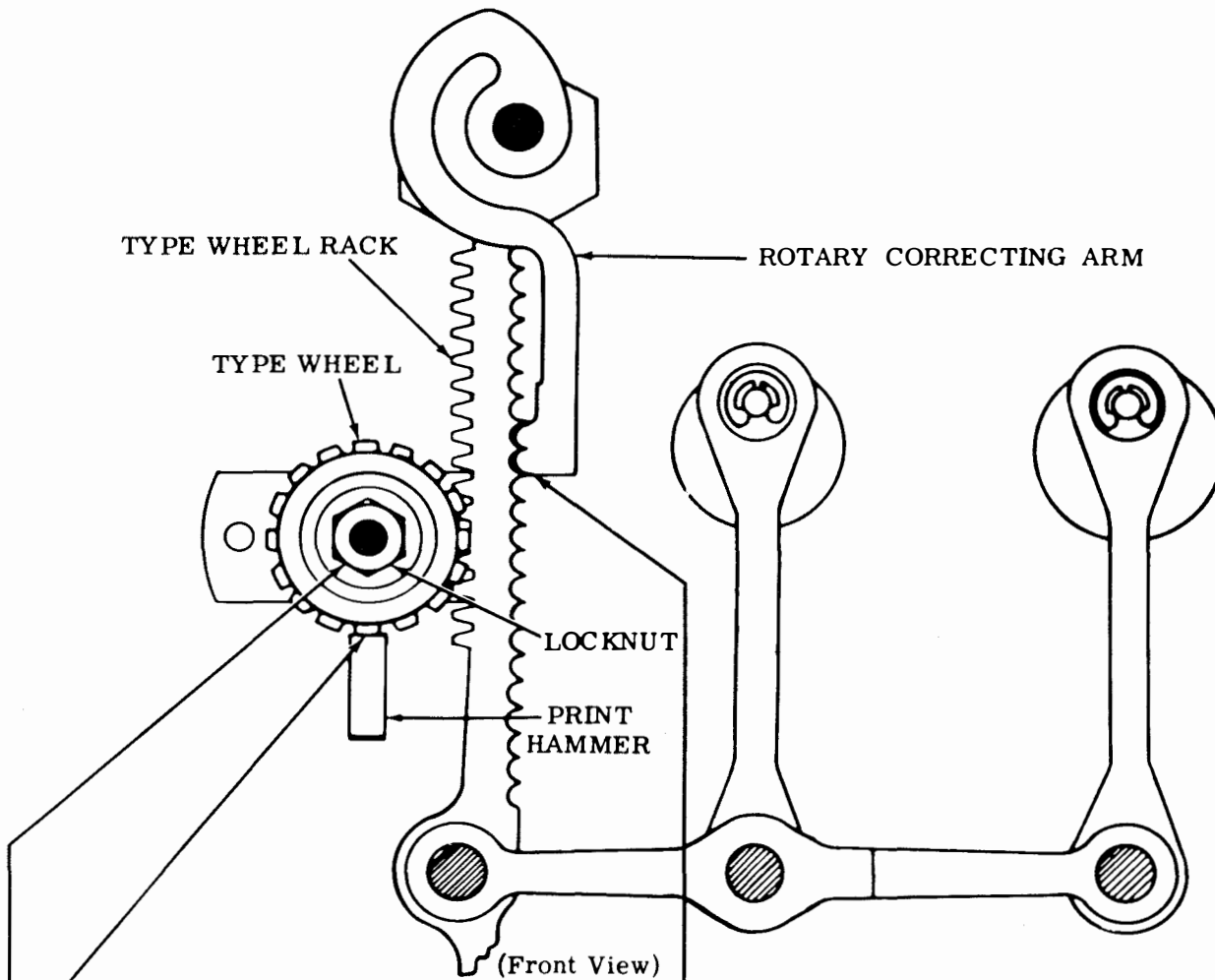

TYPE WHEEL (Preliminary)

To Check

Select H code combination (---4--78). Place rocker bail to extreme left. Correcting arm should be firmly seated in type wheel rack.

Requirement

Type wheel aligned so that full character is printed uniformly.

To Adjust

Position type wheel with locknut loosened. Check printing by manually lifting accelerator to latched position and releasing it.

Note: For best results, it may be necessary to make PRINT HAMMER (2.70) adjustment and then refine this adjustment.

TYPE WHEEL (Final)

To Check

With unit operating under power.

Requirement

All characters should be legible.

To Adjust

Refine type wheel position with locknut friction tight. Tighten locknut.

Note: For best results, it may be necessary to make the PRINT HAMMER (2.70) adjustment and refine this adjustment.

2.72 Typing Mechanism (continued)

FEED PAWL SPRING

Requirement

With rocker bail to extreme right
 Min 4 oz---Max 6 oz
 to pull feed pawl spring to installed
 length.

RATCHET WHEEL
 TORQUE SPRING

Requirement

Min 1 oz---Max 3 oz
 applied tangentially to
 the ratchet wheel to
 start it to rotate.

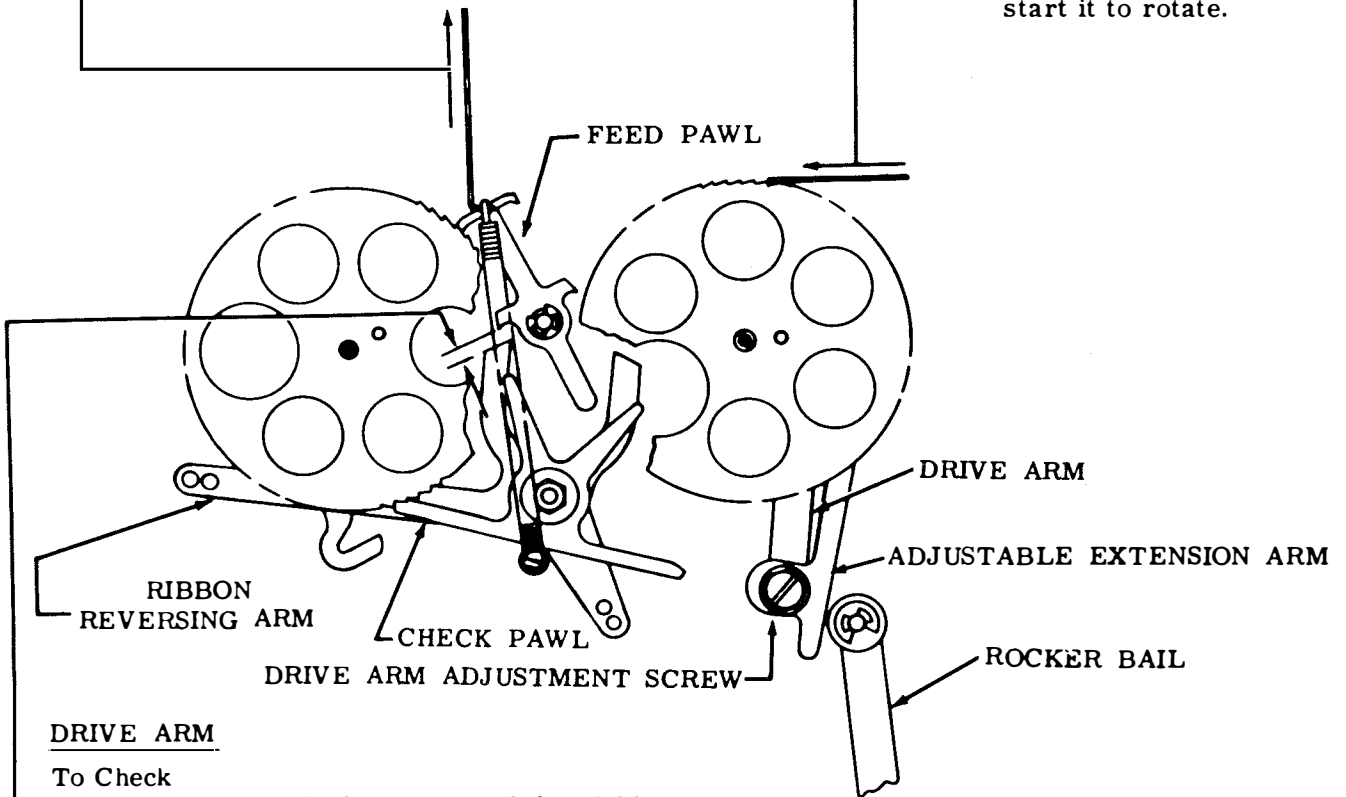

DRIVE ARM

To Check

Position rocker bail to extreme left. Hold the ribbon reversing arm under lower reversing extension of feed pawl.

- (1) Requirement
 Clearance between blocking edge of ribbon reverse arm and reversing extension of feed pawl
 Min some
- (2) Requirement
 Clearance should not be so great as to allow feed pawl to feed more than two teeth at a time.
- (3) Requirement
 Feed pawl detented in both its right and left position.

To Adjust

Position drive arm adjustable extension lever with its mounting screw loosened. Tighten screw.

2.73 Typing Mechanism (continued)

DRIVE ARM SPRING

Requirement

With rocker bail to extreme right

Min 9 oz---Max 14 oz
to pull drive arm spring to
installed length.

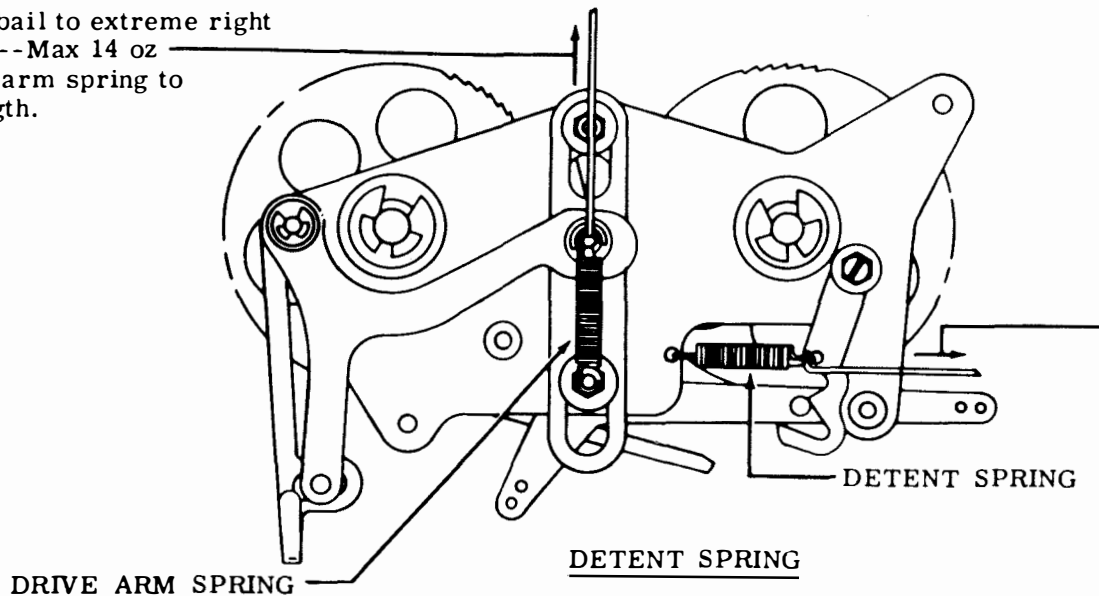

DETENT SPRING

Requirement

With reversing arm in its extreme
right or left position

Min 2 oz---Max 4 oz
to pull detent spring to its installed
length.

2.74 Keyboard Guideplate

ENDPLATE CLEARANCE

(1) Requirement

Tops of keyboard endplates should be flush with top of keytop guideplate.

(2) Requirement

Min 0.030 inch---Max 0.060 inch clearance between edge of endplates and edge of keytop guide surface.

To Adjust

Loosen four endplate mounting screws.
Adjust endplate to meet requirements.

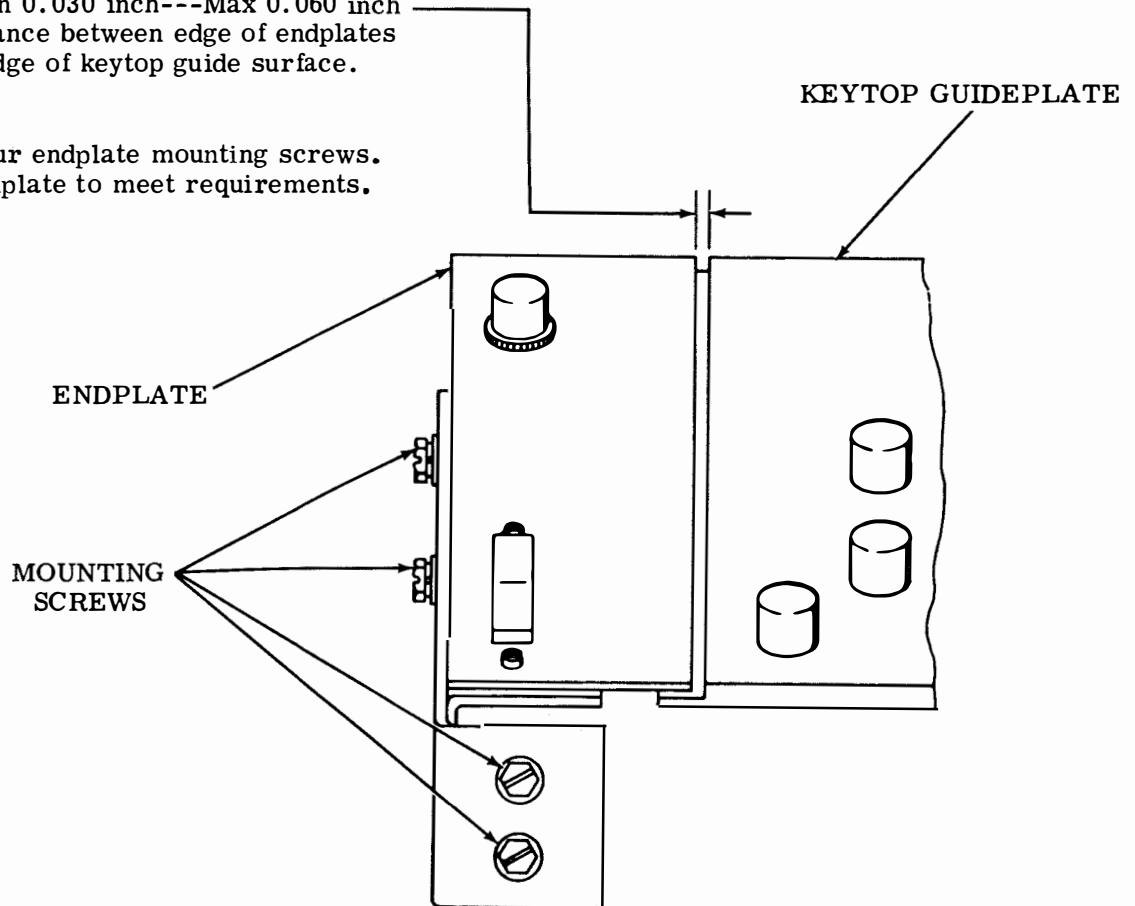
KEYBOARD CLEARANCE

Requirement

With cover resting on pan, there should be no clearance between cover and endplates and they should be parallel to each other.

To Adjust

Remove the cover. Loosen four studs that mount keyboard base to pan. Loosen bottom locking nuts on vertical adjusting posts. Raise or lower individual bushings to meet requirement by turning top hex nut to thread bushing into pan bracket. Tighten locknuts and studs. Replace cover and check endplate clearance adjustment.

2.75 Cover

LID

Requirement

All mating surfaces should be flush.

To Adjust

With lid hinge nuts friction tight, position lid to meet requirement. Tighten nuts.

PUNCH WINDOW

Requirement

Punch observation window should match contour of cover lid.

To Adjust

With window bracket nuts friction tight, position window to meet requirement. Tighten nuts.

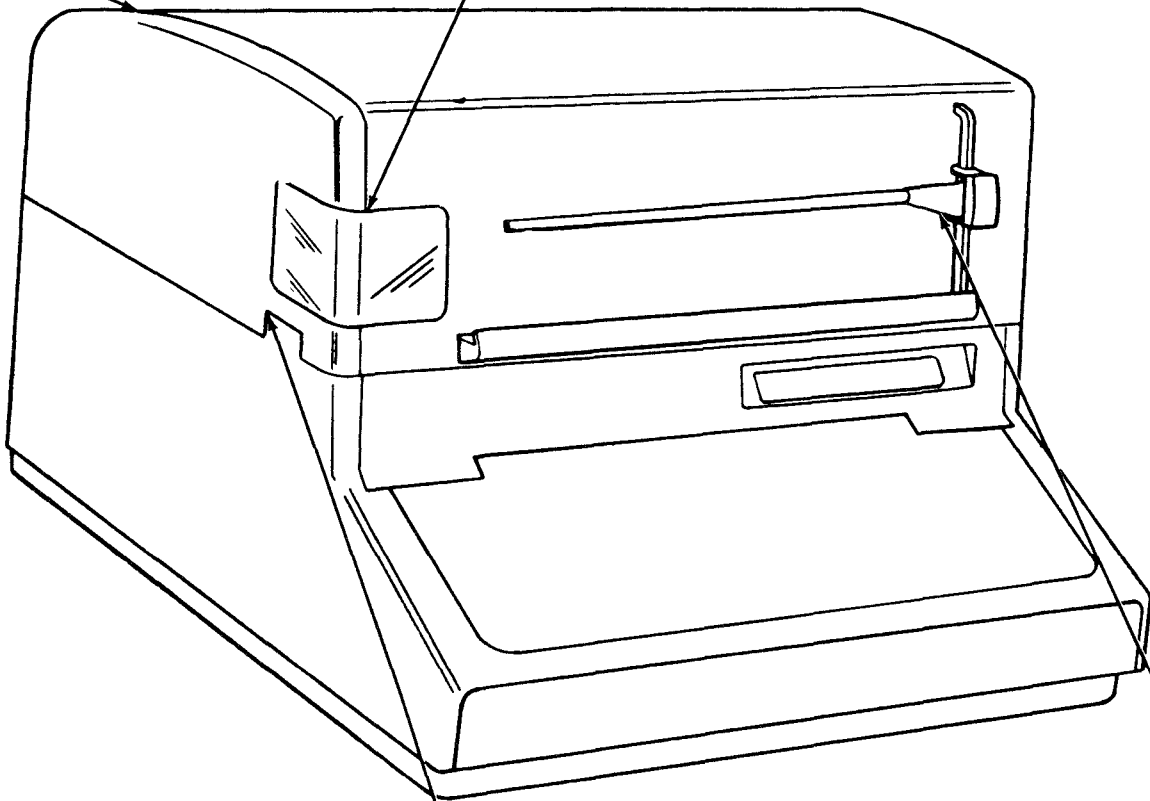

TAPE GUIDEPLATE

Requirement

With cover in place and tape in punch
Min 1/16 inch---Max 1/8 inch
clearance between top edge of tape
guideplate and bottom surface of tape after
it leaves punch in a horizontal plane.

To Adjust

With tape guideplate nuts friction tight, position plate to meet requirement. Tighten nuts.

COPYHOLDER

Requirement

Tension on line guide should be sufficient
to hold line guide from slipping down shaft
and to hold copy in place.

To Adjust

Remove screws from shaft mounting post
and turn shaft to adjust spring tension.
Replace line guide and tighten mounting
screws.

3. VARIABLE FEATURES

3.01 Print Suppression Mechanism

Note 1: Refer to Part 2 for preliminary adjustments in common with ribbon shift adjustments in all units.

Note 2: The following adjustment pertains to units that block the ribbon carrier with the shift magnet in the unattracted position.

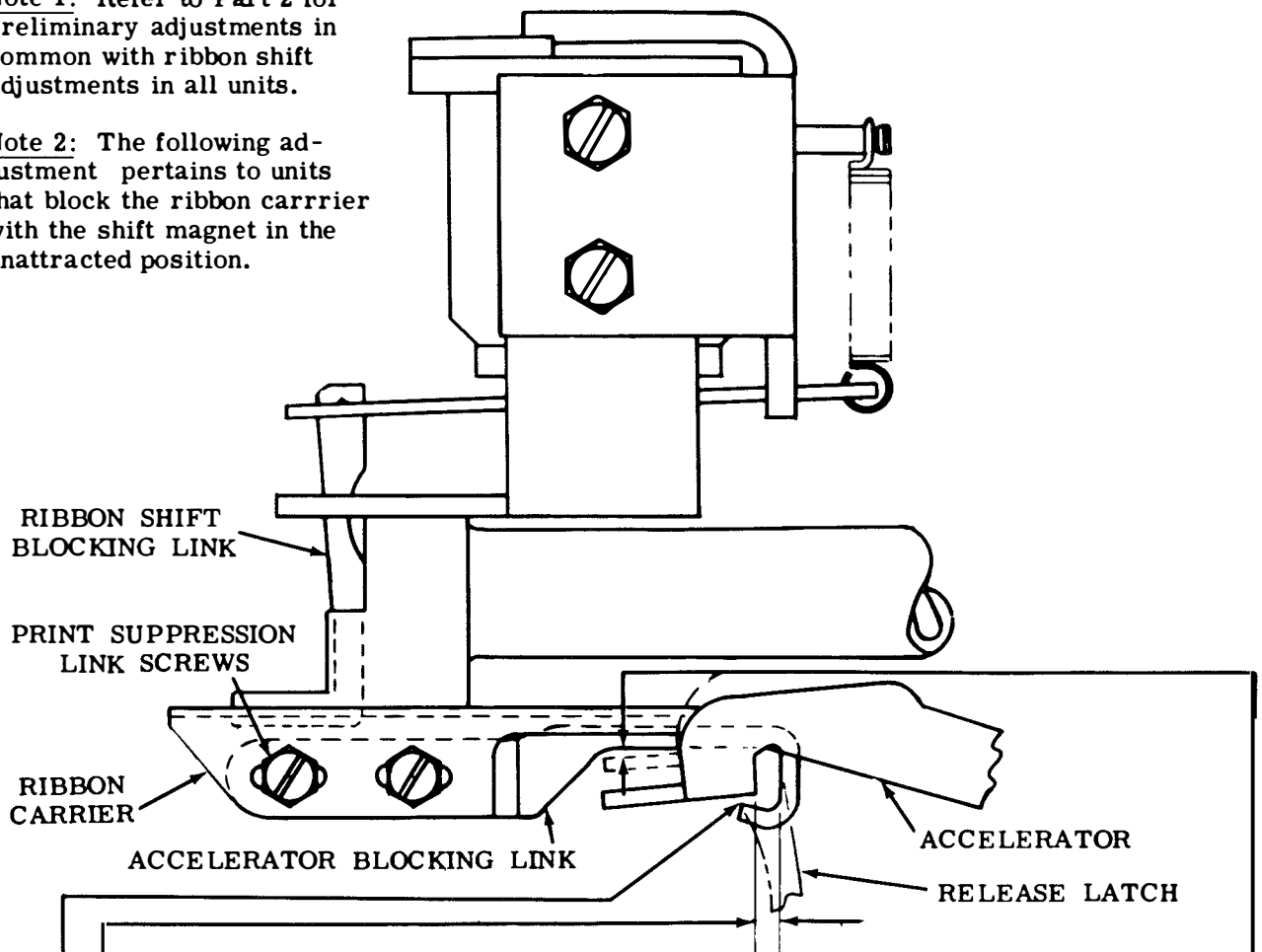

ACCELERATOR BLOCKING LINK (Late Design)

- (1) Requirement
With the rocker bail in the extreme left position, there should be
Min 0.075 inch---Max 0.095 inch
clearance between the accelerator lever and the accelerator blocking link.
- (2) Requirement
With the unit in the stop position, there should be
Min some _____
clearance between the top surface of the accelerator and the blocking link.
- (3) Requirement
With the ribbon shift magnet armature resting against its upstop screw and when the main shaft is rotated through a complete revolution, there should be
Min some _____
clearance between the accelerator and blocking link at its closest point.

To Adjust

Loosen the two screws which mount the accelerator blocking link and position the link both horizontally and vertically to meet the requirements. Tighten screws.

3.02 Print Suppression Mechanism (continued)

Note 1: Refer to Part 2 for preliminary adjustments in common with ribbon shift adjustments in all units.

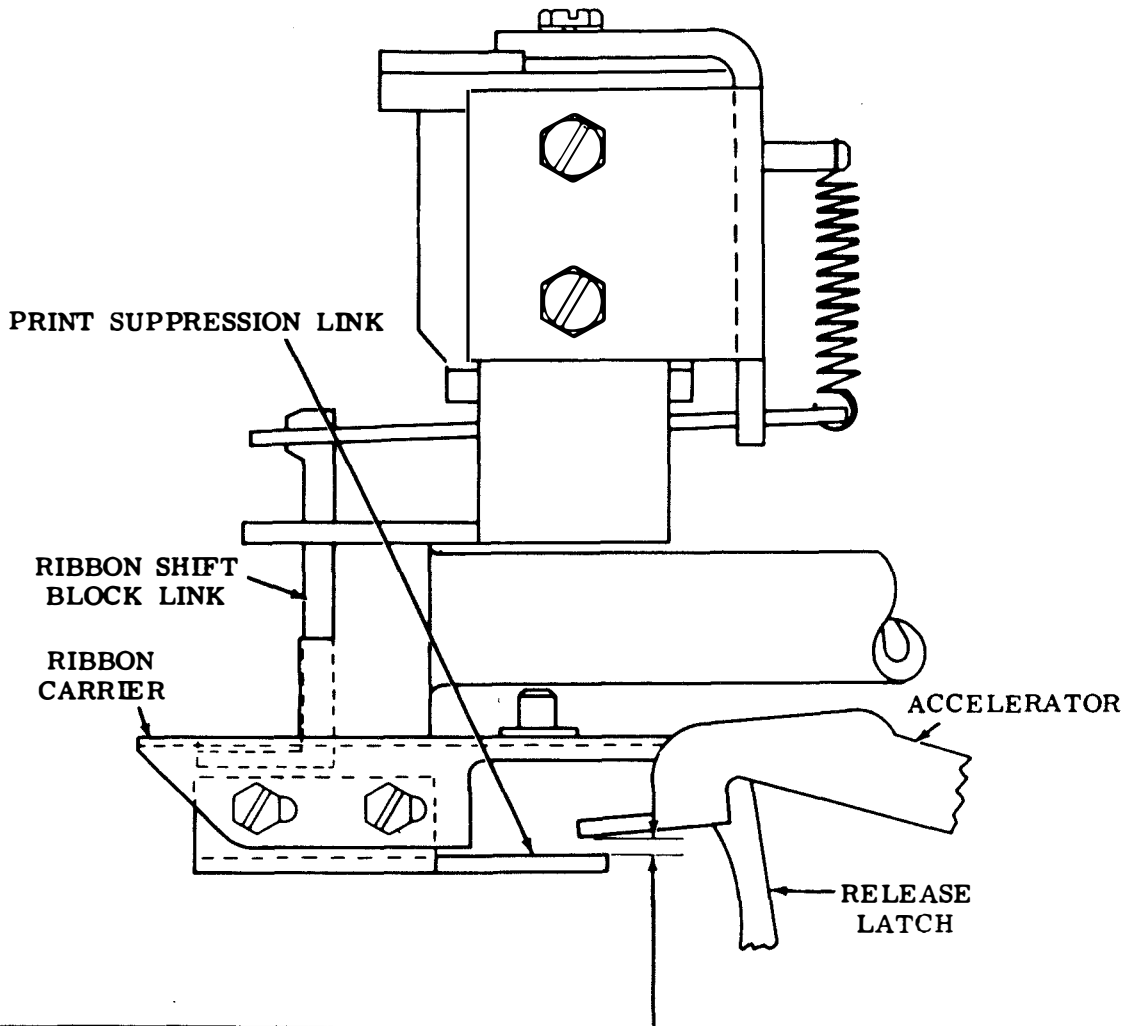

Note 2: The following adjustment pertains to units that block the ribbon carrier when the shift magnet armature is held attracted.

ACCELERATOR BLOCKING LINK (Early Design)

Requirement

Function clutch tripped and main shaft rotated until print hammer trip lever just touches print release latch. There should be

Min 0.020 inch---Max 0.030 inch
clearance between the upper surface of the print suppression link and the lower surface of the print hammer accelerator.

To Adjust

Position the print suppression link all the way to the rear of the slots on the ribbon carrier. Position link in vertical direction with mounting screws loosened to meet requirement. Tighten screws.