

24-HOUR TIMER

LUBRICATION

CONTENTS	PAGE	LUBRICATION INTERVAL
1. GENERAL	1	1.03 Lubricate at six-month intervals. Apply KS7470 oil, KS7471 grease, or 105 Lubriplate grease (TP108805) in accordance with the following code:
LUBRICATION INTERVAL	1	
2. LUBRICATION	2	
Detents	2	O1 - Apply one drop of KS7470 oil. O2 - Apply two drops of KS7470 oil. SAT - Saturate with oil. G - Apply thin film of KS7471 grease. L - Apply thin film of 105 Lubriplate.
Driving Bails	3	
Driving Cam	3	
Driving Lever	4	Take special care to avoid getting oil or grease on the electrical contacts. Specific lubricant requirements and the amount of lubrication are indicated at each lubrication instruction. The motor does not require lubrication.
Feed Pawls	4	
Holding Magnet	5	
Main Shaft	6	1.04 Prior to initial installation and at periodic lubrication intervals, soak non-metallic cams in KS7470 oil for 24 hours at room temperature after cam sleeve assemblage. Apply a light film of 107 Lubriplate grease to the cam peripheries.

1. GENERAL

1.01 This section is reissued to incorporate the latest engineering changes for the 24-hour timer (Figures 1 and 2). Since this is a general revision, marginal arrows ordinarily used to indicate changes and additions have been omitted.

1.02 Lubrication requires removal of the timer from its mounting bracket and disconnecting the ac power supply. Be sure to reset the timer when reinstalling it. Refer to the section entitled "24-Hour Timer, Description and Principles of Operation."

CAUTION: DO NOT USE ALCOHOL, MINERAL SPIRITS, OR OTHER SOLVENTS TO CLEAN PLASTIC PARTS OR PARTS WITH PROTECTIVE DECORATIVE FINISHES. NORMALLY, A SOFT, DRY CLOTH SHOULD BE USED TO REMOVE DUST, OIL, GREASE, OR OTHERWISE CLEAN PARTS OR SUBASSEMBLIES. IF NECESSARY, A SOFT CLOTH DAMPENED WITH SOAP OR MILD DETERGENT MAY BE USED. AFTERWARDS, RINSE PART OR SUBASSEMBLY WITH A SOFT, DAMP CLOTH AND BUFF WITH A SOFT, DRY CLOTH.

2. LUBRICATION

2.01 Detents (Three)

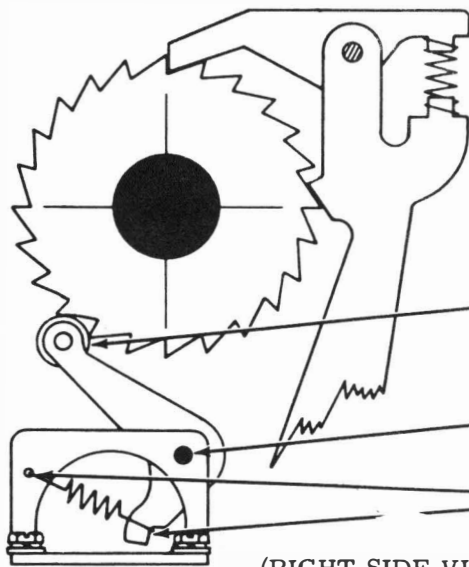

- O2 Rollers (3 Places) Detent Rollers
- O2 Pivot Points (3 Places) Mounting Screw
- O2 Hooks - Each End Spring

2.02 24-Hour Timer (Left Rear View)

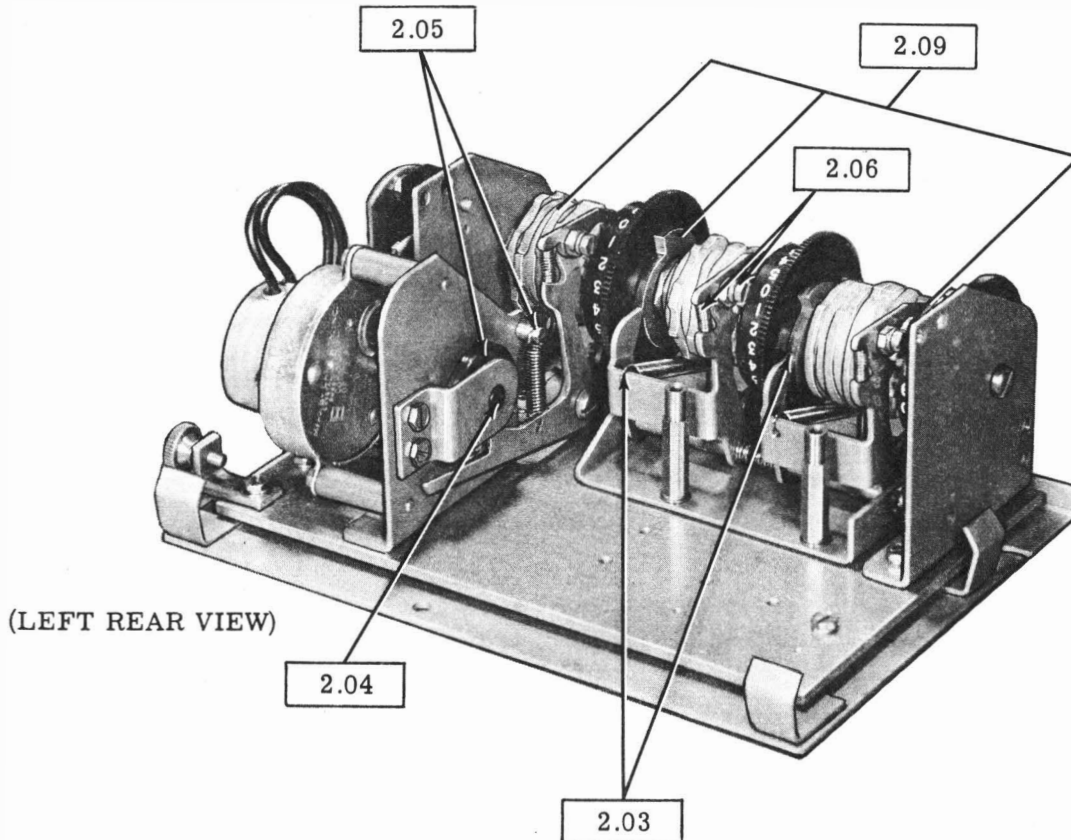

2.03 Driving Bails (Two)

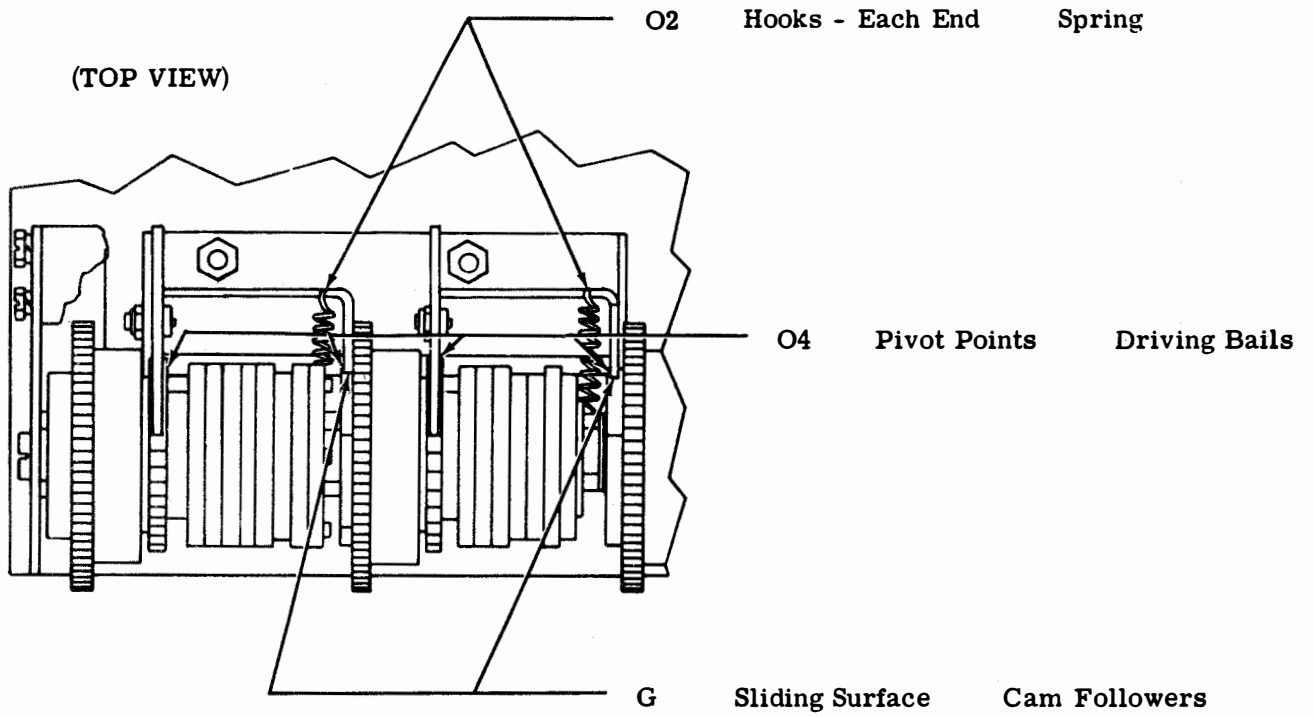

2.04 Driving Cam

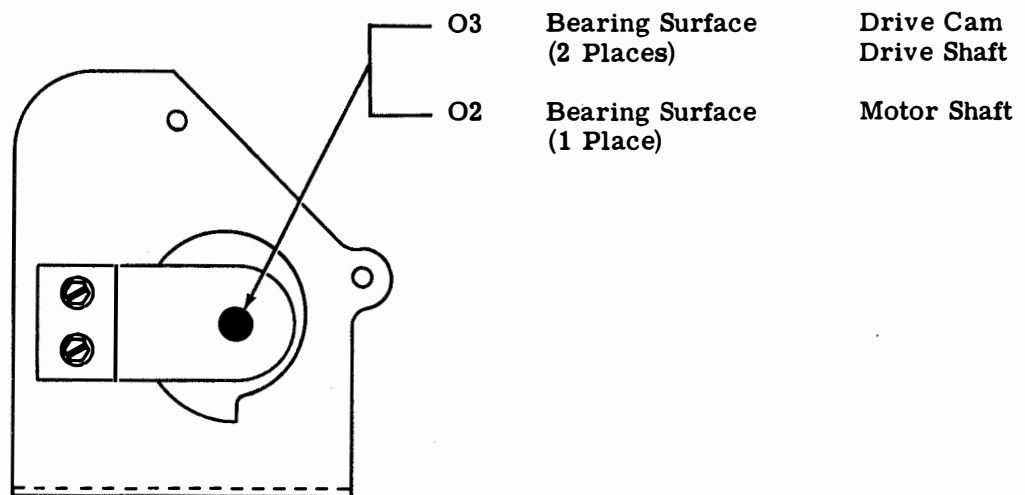

2.05 Driving Lever

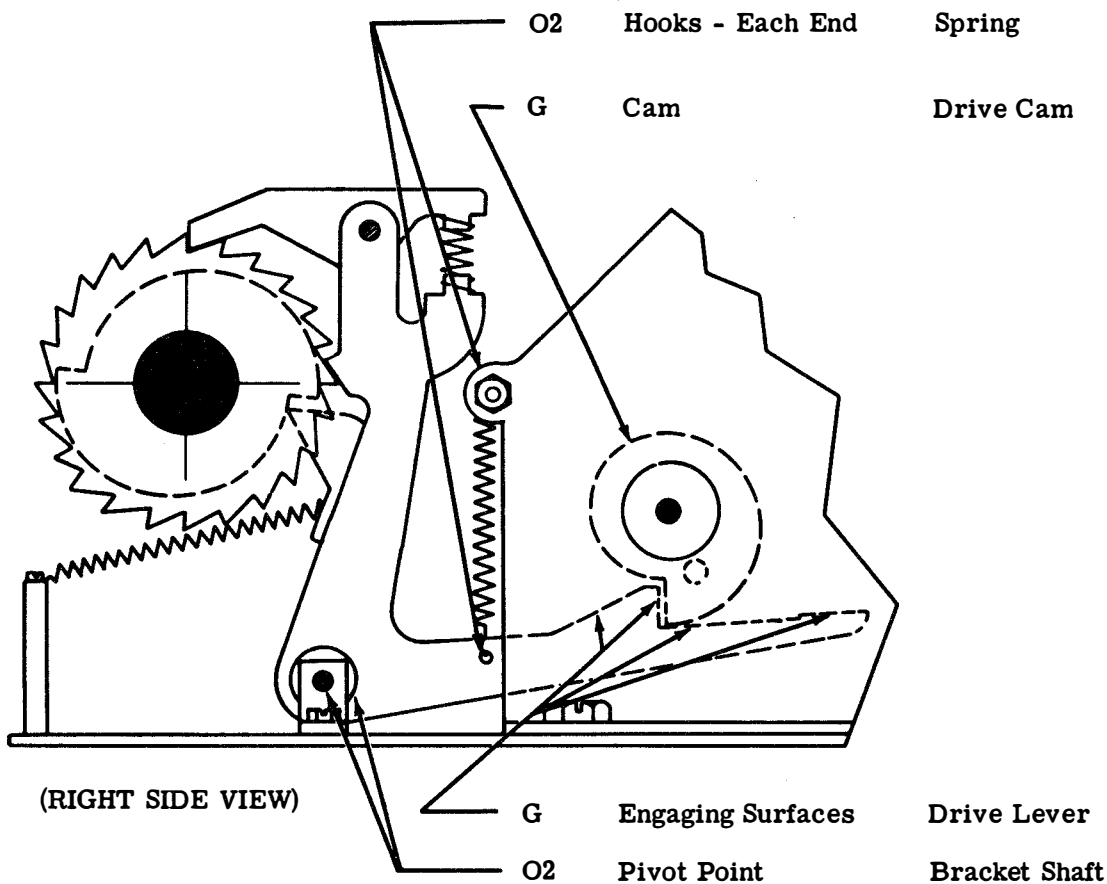

2.06 Feed Pawls

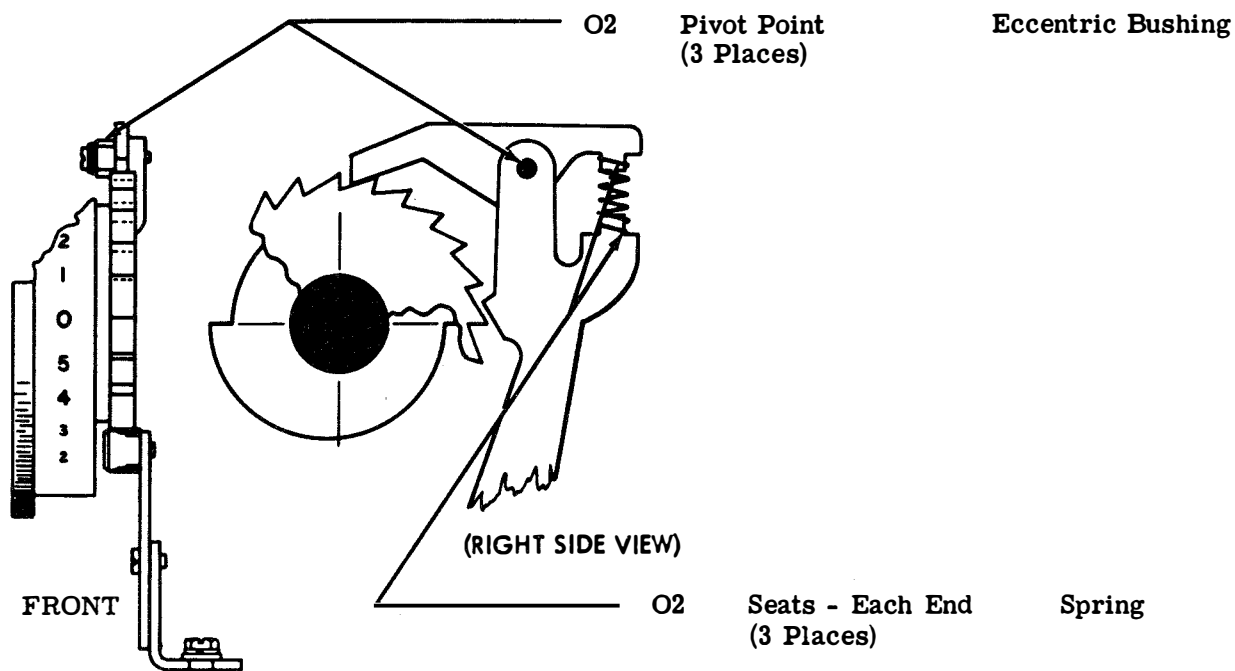

2.07 24-Hour Timer (Rear View)

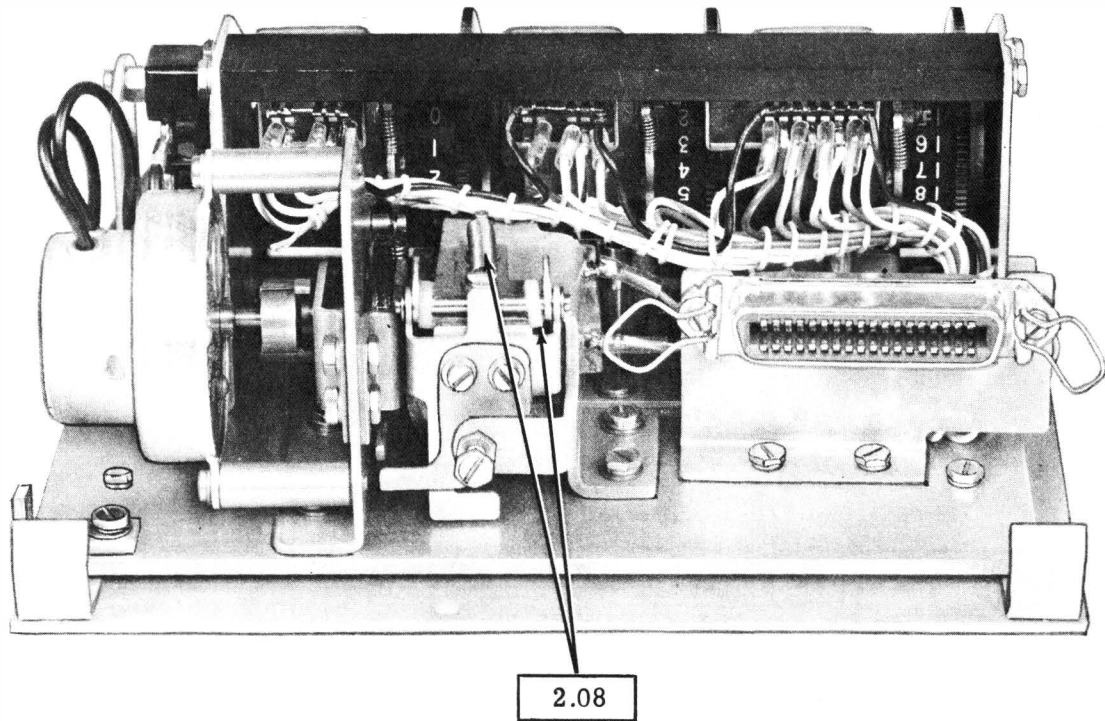

2.08 Holding Magnet

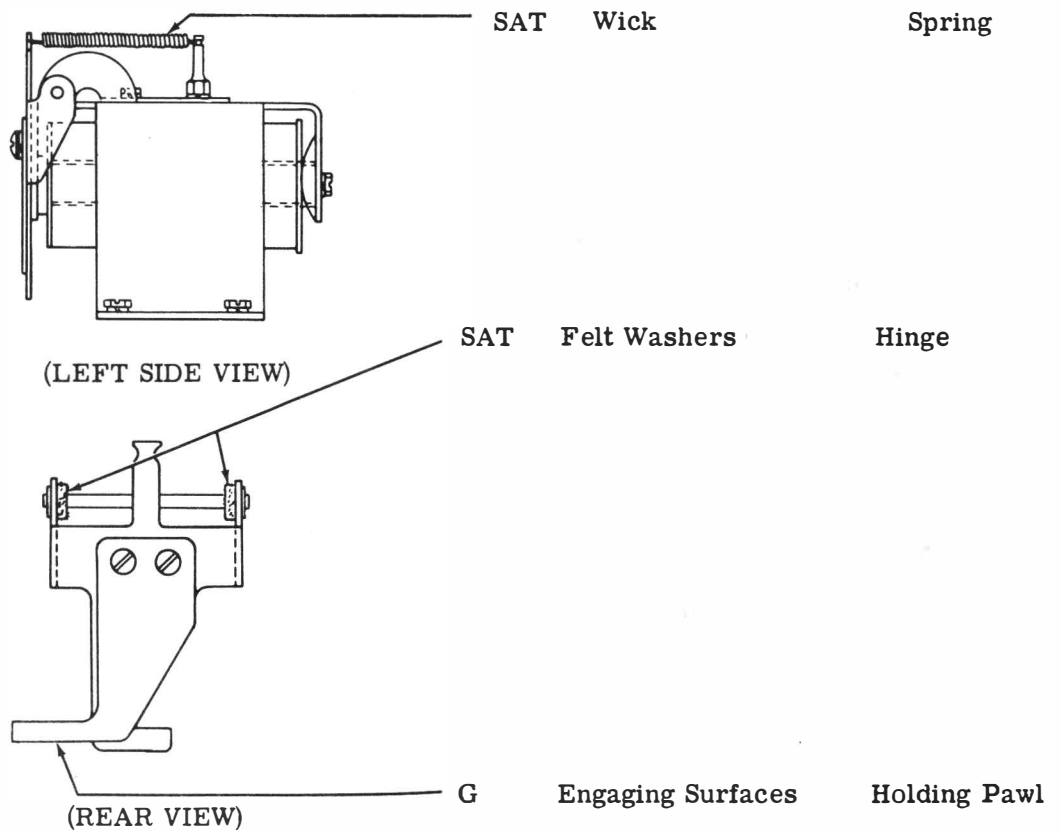

2.09 Main Shaft

