



Teletype Corporation

the **43 teleprinter**

INSTALLATION
& ROUTINE SERVICING

for

BUFFERED SEND RECEIVE TERMINALS

MANUAL 451

Teletype Corporation Product Service and Education Services

On the following page is a list of Teletype Corporation Product Service locations which provide maintenance service and repair on all Teletype Corporation products. For more information call toll free (US 800-323-4226) (IL 800-942-4192) 7:00 A.M. — 4:00 P.M. CST.

In addition, Teletype Corporation provides customer technical training at its headquarters at 5555 W. Touhy Avenue, Skokie, IL in the northwest suburban area of Chicago. The training covers the installation, maintenance and repair of all Teletype Corporation products. Arrangements can also be made for training to be conducted at customer-selected field sites.

For information about class schedules, enrollment, tuition, on-site training or any special training needs, please contact:

Education Services
Teletype Corporation
5555 W. Touhy Avenue
Skokie, Illinois 60077
Telephone (312) 982-3940
TLX 25-4051
TWX 901-223-3611

THE 43 TELEPRINTER
INSTALLATION AND ROUTINE SERVICING MANUAL
FOR
BUFFERED SEND/RECEIVE TERMINALS

INDEX	PAGE
PART 1 -- INTRODUCTION	1-1
PART 2 -- INSTALLATION	2-1
A. SWITCH ENABLED OPTIONS	2-1
B. EIA DATA SET INTERFACE SIGNALS	2-2
C. ASSEMBLY	2-3
1. UNPACKING.	2-4
2. STATION ASSEMBLY	2-4
3. STATION TESTING.	2-7
D. INITIATE SERVICE	2-7
E. CABLE WIRING	2-8
PART 3 -- ROUTINE SERVICING.	3-1
A. TROUBLE ISOLATION AND CORRECTION	3-1
1. TROUBLESHOOTING GUIDE.	3-1
2. CONTROLLER SELF-TEST	3-4
3. PRINTER LOCAL TEST	3-5
B. PERIODIC CHECKS, LUBRICATION AND CLEANING.	3-5
1. GENERAL.	3-5
2. VISUAL CHECKS.	3-5
3. CLEANING AND APPEARANCE.	3-6
4. LUBRICATION PROCEDURES	3-6
5. LUBRICATION POINTS	3-8
C. COMPONENT LOCATION AND ACCESS.	3-11
1. KEYBOARD, PRINTER, LOGIC CARD, SWITCHES AND INDICATORS	3-11
2. POWER SUPPLY LAMP AND FUSE, CONTROLLER CABLE, LED AND TEST SWITCH.	3-12
3. POWER SUPPLY 115/230 V OPTION STRAP.	3-12
4. TRACTOR.	3-15
D. ADJUSTMENTS.	3-16
1. RIGHT PAPER SPROCKET	3-16
2. PLATEN ENDPLAY	3-16
3. PRINTED LINE POSITION.	3-17
4. PRINTED LINE POSITIONING	3-18
5. IDLER GEAR TO PRINTER PLATEN GEAR.	3-18
6. PAPER SENSING ARM.	3-20
PART 4 -- ASSOCIATED DOCUMENTS AND ACCESSORIES	4-1

PART 1 -- INTRODUCTION

All information necessary to install, operate and maintain the 43 Buffered Send/Receive Teleprinter in service for its lifetime, provided no troubles occur, is provided in the documents which are intended to be furnished with the teleprinter. These documents are furnished in the packing carton (with factory assembled sets) or should be ordered and furnished separately (for sets assembled in the field). The documents are listed in PART 2 -- INSTALLATION of this manual, Page 2-1.

The purpose of this manual is to provide the information required to install and maintain the 43 Buffered Send/Receive Teleprinter. The instructions provided are for service personnel with a minimum of training, and using the tools and spare parts listed to enable options, properly interface the teleprinter in a pre-engineered system and to check basic operability and proper installation. Also, minimal troubleshooting, disassembly/reassembly, and adjustments associated with installation in addition to instructions to routinely service, clean and lubricate the 43 Tabletop Buffered Send/Receive Teleprinters are provided in this manual.

The 43 Buffered Send/Receive Teleprinter terminal provides for off-line data preparation (Message Enter, Edit, and Store), batch transmission, and line speeds higher than the continuous printing rate. Messages may be prepared locally from the keyboard, edited and stored in the send buffer while messages being received are stored in the receive buffer. The total amount of data that can be stored in the send and receive buffers is determined by the 16K memory size provided, minus approximately 600 characters dedicated to the terminal. This dedicated area includes an option store programmable by the user.

The terminal can operate at 110, 200 (150 on sets with RETRV REC key), 300, 600, 1200 or 1800 baud using an 8-bit character structure in an asynchronous format with 33/35 American National Standard Code for Information Exchange (ASCII) protocol. The matrix style printer uses a 7 by 9 matrix to produce uplow character shapes for ASCII printing graphics and special symbols for 32 ASCII control codes.

The teleprinter may use a pin, friction or tractor feed printer. The pin feed printer may be optioned for line lengths up to 132 columns, prints approximately 13 characters per inch, and uses 12 inch wide pin feed paper. The friction feed printer may be optioned for line lengths up to 80 columns, prints approximately 10 characters per inch and uses 8-1/2 inch wide friction feed paper. The tractor feed printer may be optioned for line lengths up to 100 columns, prints approximately 10 characters per inch and may use 3 inch to 12 inches wide pin feed paper.

Terminal interface is EIA type RS-232-C* and is intended for use with a customer provided full duplex data set similar to the 103J, 108D, 202T or 212A, for use on switched network or private lines.

Depending upon the set code, a terminal power source may be 115 Vac or 230 Vac. Power cords are furnished with 115 Vac terminals but must be ordered separately for 230 Vac terminals.

How To Operate Manual 386 and this Installation and Routine Service Manual 451 are furnished in the carton with factory assembled sets but must be furnished separately with field assembled sets. Refer to PART 4 -- ASSOCIATED DOCUMENTS AND ACCESSORIES for other servicing and repair documents.

Information on how to change user programmable options, check proper operation, change the ribbon cartridge and install paper is included in the How To Operate manual furnished with each terminal.

NOTE: When ordering replaceable components, unless otherwise specified, prefix each part number with the letters "TP" (ie, TP410055).

Tools and spare parts that may be required are as follows:

DESCRIPTION	TELETYPE CORPORATION PART NO.
3/16"and 1/4" Open-End Wrench	129534
1/4" 6"Blade, Screwdriver	100982
1/16"Allen Wrench	124682
1.0 A SLOW-BLOW Fuse	143306
1.0 A Fuse	120139
Lubricants	See Page 3-5
Connector, Adapter (see Page 3-3)	403378

In the event that troubles occur that cannot be corrected with the information in this manual, refer to the Service Manual 406, replace the terminal, or contact the nearest Teletype Corporation Product Service Center. See Page II.

*See Teletype Corporation Technical Reference for 43 Buffered Send/Receive Tele-printer Terminals.

PART 1 -- INTRODUCTION (Contd)

The 43 Buffered Send/Receive teleprinters can be identified as shown below:

<u>TELEPRINTER CODE</u>	<u>SET DESCRIPTION</u>	<u>POWER (Vac)</u>
4340/BAB	Buffered 43 SR (P)	115
4340/BAD	Buffered 43 SR (F)	115
4340/BAJ	Buffered 43 SR (T)	115
4340/BAL	Buffered 43 SR (P) w/ER [†]	115
4340/BAM	Buffered 43 SR (F) w/ER [†]	115
4340/BAN	Buffered 43 SR (T) w/ER [†]	115
4340 BZD + 43 FG210/AA/01	Buffered 43 SR (F) w/ER [†]	115
4340 BZD + 43 FG210/AA/02	Buffered 43 SR (F) w/ER [†]	115
†4340 BZE + 43 FG210/AA/01	Buffered 43 SR (P)	230
†4340 BZE + 43 FG210/AA/02	Buffered 43 SR (P) w/ER [†]	230
†4340 BZF + 43 FG210/AA/01	Buffered 43 SR (F)	230
†4340 BZF + 43 FG210/AA/02	Buffered 43 SR (F) w/ER [†]	230
†4340 BZK + 43 FG210/AA/01	Buffered 43 SR (T)	230
†4340 BZK + 43 FG210/AA/02	Buffered 43 SR (T) w/ER [†]	230
†4340 BZJ + 43 FG210/AA/01	Buffered 43 SR (T)	115
†4340 BZJ + 43 FG210/AA/02	Buffered 43 SR (T) w/ER [†]	115

†Refer to Specification 51049S that is included with these terminals for additional material required to complete assembly (feature groups, keytop kits, documents, etc).

* Enhanced Retrieve

TERMINAL CODE PLATE LOCATION

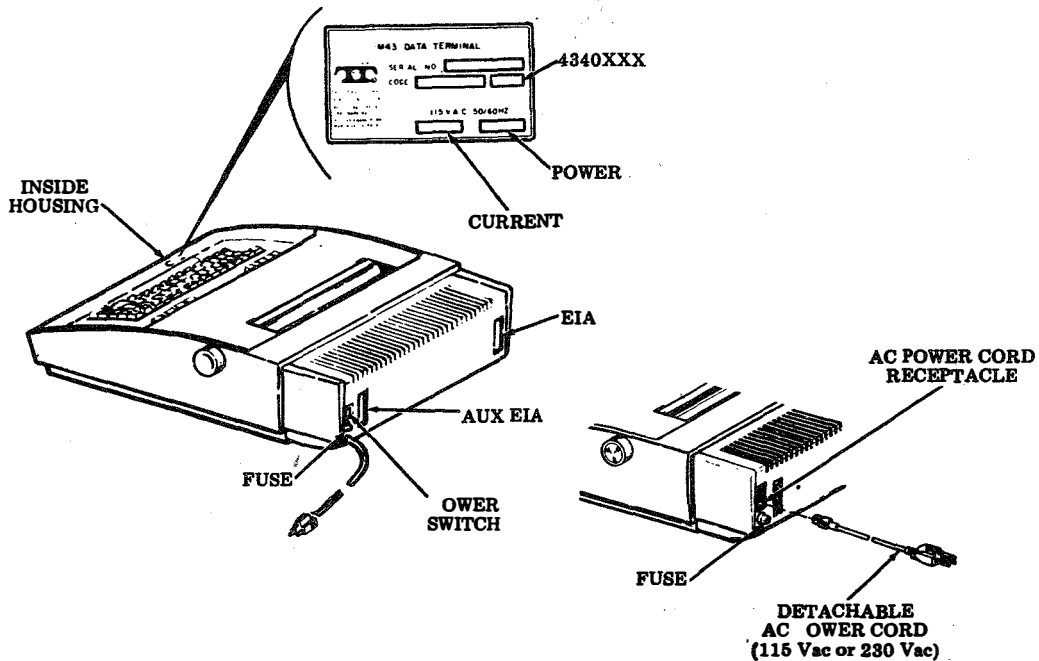

PART 2 -- INSTALLATION

A. SWITCH ENABLED OPTIONS

The chart below describes options not programmable by the user and provides information on how to verify or change the setting of these switch options on the logic card after the terminal is unpacked.

OPTION NO.	OPTION SUFFIX AND CONDITIONS	OPTION DEFINITION	SWITCH PACK LOCATION ON CIRCUIT CARD (See Component Access, Page 3-11.)				
			SWITCH NUMBERS				
XXX			SPB6				
a.			1	2	3	4	5
b.							

431. Type Font Arrangement	SPB6				
	1	2	3	4	5
a. Narrow Numeric 0 and Wide Alpha O Standard ^ and Underline _.	●	●	-	-	- *
b. Slash Numeric 0 and Wide Alpha O. ^ Prints as ↑ and _ Prints as ←.	○	●	-	-	-
c. Slash Alpha 0 and Wide Numeric O. ^ Prints as ↑ and _ Prints as ←.	○	○	-	-	-
d. Slash Alpha 0 and Wide Numeric O. Standard ^ and Underline _.	●	○	-	-	-

Switches Must be Set as Shown.										
					SPB6					
					1	2	3	4	5	
					-	-	○	○	○	*

NOTE: Switch 5 ON enables printer test.

485. Options Load (for sets with RETRV REG key only)	SPA7			
	1	2	3	4
a. Enabled	-	●	-	-
b. Disabled	-	○	-	-

Switches Must be Set as Shown.							
				SPB7			
				1	2	3	4
				●	-	●	●

430760 POWER SUPPLY ONLY

473. 115/230 Vac Teleprinter Operation	ST2 (410703 CARD) SW2 (410704 CARD)	SET LINE FUSE F1
a. 230 Vac	In 230 V position	143306 1.0A SLO-BLO *
b. 115 Vac	In 115 V position	341686 1.5A SLO-BLO

- Indicates toggle or slide position to ON.
- Indicates toggle or slide position to OFF.
- Position of switch does not affect feature.
- * Factory furnished state of feature.

B. EIA DATA SET INTERFACE SIGNALS

The EIA leads that appear at the interface (EIA designations in parenthesis) are defined below in terms of common designations. Arrows indicate direction of data flow or control.

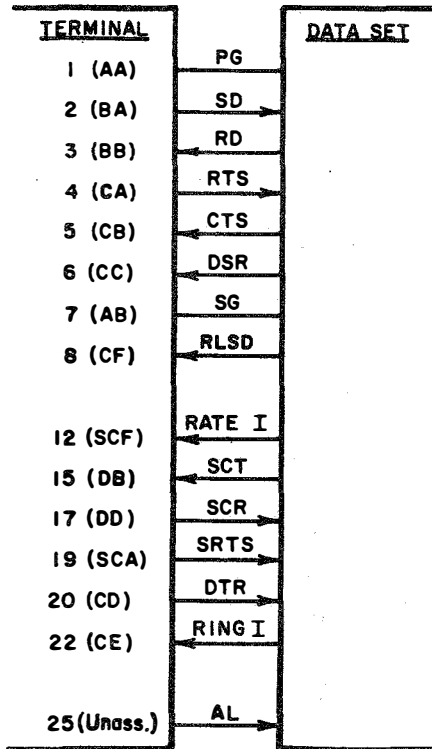

- CTS** — Clear To Send. On allows teletypewriter to send or receive. Off teletypewriter can receive but not send.
- DSR** — Data Set Ready. DSR and CD on puts teletypewriter in Term On Line mode if DTR is on. If DSR is off teletypewriter switches from Term On Line to Term Ready.
- SG** — Signal Ground.
- RLSD** — Received Line Signal Detect. RLSLSD and DSR on puts teletypewriter in Term On Line mode if DTR is on. If RLSLSD turns off, teletypewriter remains in Term On Line mode for approximately 20 seconds then switch to Term Ready. Data will appear to be sent but will not. If RLSLSD is restored in less than 20 seconds sending will resume with possible loss of one or two characters.
- SRTS** — Secondary Request To Send. Wired internally always off.
- RATE I** — Rate Indicator. Controlled by dual speed data set. Off is low speed and on is 1200 Baud. If not connected or user programmable, Option 212 = n then speed is determined by Option Speed.
- SCT** — Serial Clock Transmit. Wired but not active in terminal.
- SCR** — Serial Clock Receive. Wired but not active in terminal.
- DTR** — Data Terminal Ready. Off if teletypewriter in Term Local, on if teletypewriter in Term Ready or Term On Line mode. Receipt of Dscnt (Option) character or depression of Term Ready if in Term On Line mode turns off DTR for 50 ms. Alarm condition turns off DTR if in Term Ready mode. Alarm does not turn off DTR if in Term On Line mode. Off when Controller Self-Test is entered.
- RING I** — Ring Indicator. On condition Primes terminal answer-back. Not connected is an off.
- AL** — Analog Loopback. Wired internally, always off. Analog loop is under control of data set.

Electrical Characteristics

EIA (RS232) Interface	Electrical Characteristics	
	From 43	To 43
State 0 (space) On	+3 to +25 V dc	+3 to +25 V dc
State 1 (mark) Off	-3 to -25 V dc	-3 to -25 V dc

- PG** — Protective Ground.
- SD** — Send Data. Mark in all modes. Varies when on-line and sending data. CTS, DSR, RTS, DTR, and RLSLSD must be on to enable sending.
- RD** — Receive Data. In state supplied by Data Set. DSR, DTR and RLSLSD must be on to enable receiving.
- RTS** — Request To Send. On if DTR and DSR are on.

C. ASSEMBLY

The 4340BAB, BAD, BAJ, BAL, BAM and BAN Buffered Send/Receive Terminals are furnished in a single carton. These terminals are fully assembled at the factory. The 4340BZD, E, F, J and K terminals are factory furnished without application program cards. Data set cord and the paper required must be ordered or furnished separately. (See note below.)

CAUTION: TO AVOID CONDENSATION ON THE ELECTRICAL COMPONENTS, THE TERMINAL SHOULD BE ALLOWED TO ASSUME ROOM TEMPERATURE BEFORE UNPACKING, FOR EXAMPLE, WHEN BROUGHT INTO A WARM HUMID ROOM FROM OUTSIDE SUBZERO TEMPERATURES.

1. UNPACKING

- a. Unpack the carton or cartons and remove the contents.
- b. Remove tape securing the cover to the housing (see next page).
- c. Depress the cover locking tabs on the lower front of the cabinet and lift the cover. Remove the packing detail securing the print head (see next page).
- d. Verify that the following items are at the installation site:

1 - 43 Terminal (4340BAB, BAD, BAJ, BAL, BAM or BAN)
 1 - Ribbon
 1 - Manual, Simplified Reference Guide, 577
 1 - Manual, Installation and Routine Servicing, 451, Issue 3
 1 - Manual, How To Operate, 386, Issue 5
 1 - Paper Holder† (Pin Feed) or 1 - Paper Supply Assembly (Friction Feed)

or

1 - 43 Terminal (4340BZD, D, E, F, J or K)
 1 - Feature Group‡ (43FG210/AA/01 or 43FG210/AA/02)
 1 - Manual, Installation and Routine Servicing, 451 Issue 3
 1 - Manual, Simplified Reference Guide, 577
 1 - Manual, How To Operate, 386, Issue 5
 1 - Paper Holder† (Pin Feed) or 1 - Paper Supply Assembly (Friction Feed)
 1 - AC Power Cord (115V Sets only)
 1 - Specification 51049S

† Not furnished with tractor feed.

NOTE: Fan-fold 12 by 8-1/2 inch paper (pin feed), 8-1/2 inch wide by 5 inch diameter rolls (friction feed), or paper for tractor must be obtained locally or ordered separately. Refer to How To Operate manual for paper suppliers. Packing detail and carton can be retained and reused in the event it is necessary to further ship or return the terminal.

‡ Specification 52049S included in feature group which should already be installed lists all parts, documents and assembly instructions required for your installation.

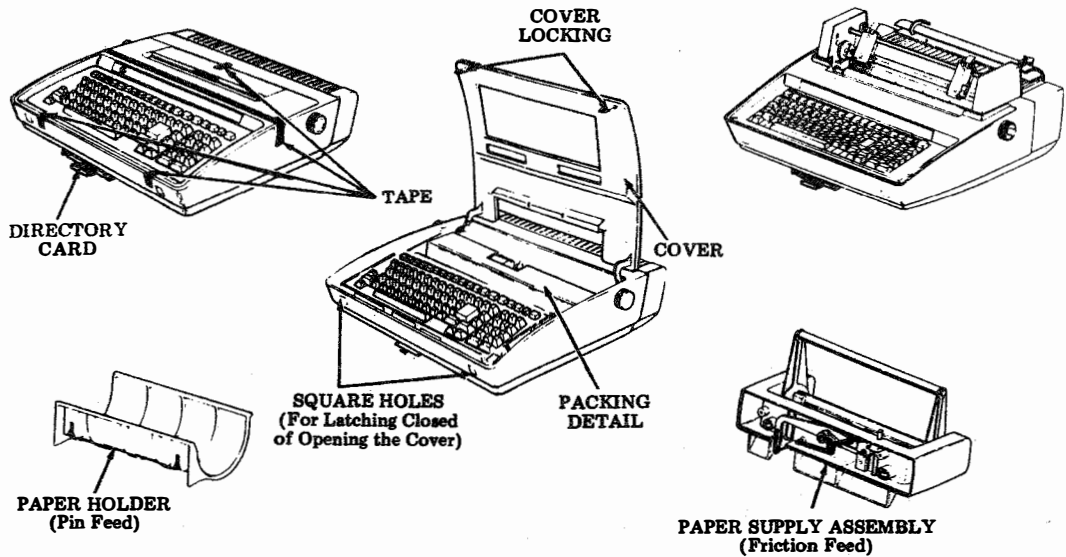
C. ASSEMBLY (Contd)1. UNPACKING (Contd)2. STATION ASSEMBLY

- a. Position the terminal in the location specified by the customer. A minimum of 6 inches of space behind the terminal is required when the paper holder (pin or friction) is used to feed the paper and 9 inches of space is required when pin feed paper is fed from a box located on the floor behind the terminal. Additional space is required if paper with folded form lengths greater than 8-1/2 inches is used. The ac power cord extends 6 feet to the rear. Power cord should be plugged in with the power switch turned off. (Bottom of rocker switch in.)

NOTE 1: Connect the data set and terminal power cords to a properly polarized and grounded source of 115 Vac power (50 or 60 Hz). Normally the power cords should be connected to unswitched outlets to avoid loss of stored data or call disconnects. Fuse protection should be time delayed and provide for a running current of 0.8A for the terminal. (1A Slow-Blow Fuse)

- b. Install the friction feed paper supply assembly or the pin feed paper holder, if desired. If the paper holder is not used, retain and store separately for possible future use. Refer to Page 3-12.
- c. With ac power to the customer supplied data set turned off, connect the EIA data set cable to the EIA terminal of the teleprinter and the data set. Secure using two captive screws on each plug. The following shielded EIA cables are available from Teletype Corporation.

<u>Cable</u>	<u>Part No.</u>
3 foot length	430569
7 foot length	408065
12 foot length	408066
25 foot length	408067
50 foot length	408068

NOTE 2: Data set must be located within 50 cable feet from the terminal.

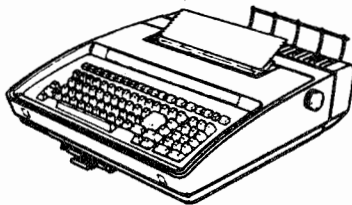

Buffered KSR (Pin Feed)

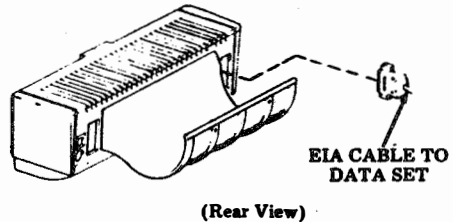

Buffered KSR (Friction Feed)

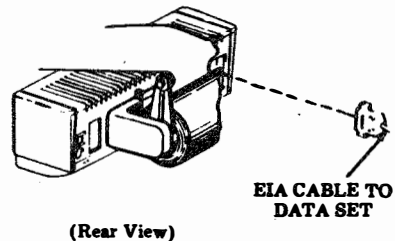

3. STATION TESTING

A minimum checkout (refer to How To Operate Manual 386) should be performed to assure that cables have been properly connected and that the terminal is basically operable.

D. INITIATE SERVICE

1. Provide the customer with the How To Operate manual.
2. Advise customer of availability of operator advisor training from Teletype Corporation, to provide training to the operator for operation of the terminal in addition to the How To Operate manual. Specific instructions on use of the terminal in the system may also be required.
3. Discuss source of replacement ribbons and paper. (See How To Operate manual.)
4. Inform customer of any user programmable options and other variations that may have been set. (Refer to Option 485.) Direct attention to the directory card, and that set is a tabletop version of the buffered 43 teleprinter.
5. On pin and tractor feed sets, if paper is fed from a supply box, advise the customer that:

Paper must be aligned with teleprinter paper feed path
Paper holder may be removed (pin feed)
Teleprinter cables should not interfere with paper
6. If continuous unattended operation is intended, a means to accumulate paper or forms should be used.

E. CABLE WIRING

An EIA cable and a connector with pin numbers are shown below.

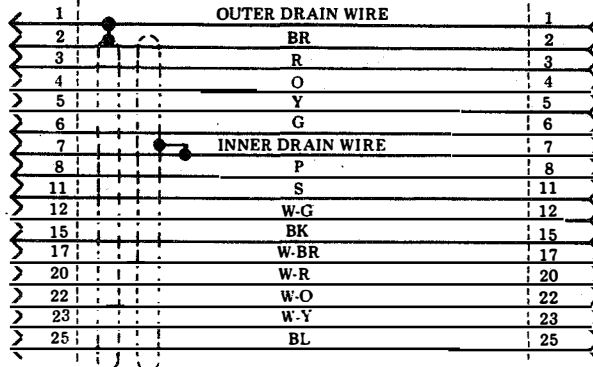
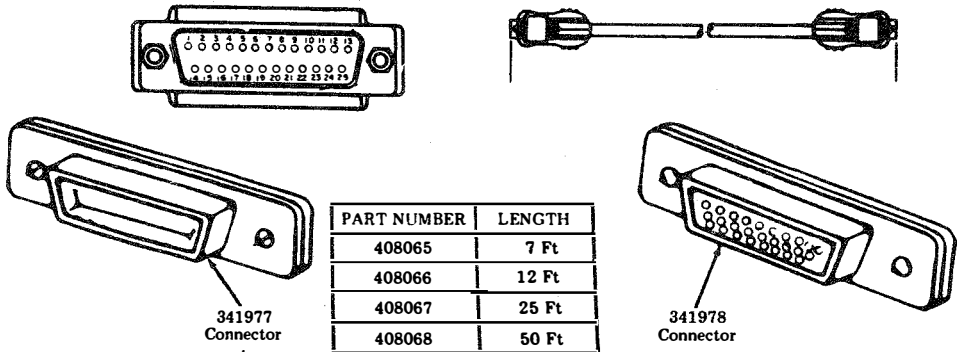

341977
Connector

PART NUMBER	LENGTH
430569	3 Ft

341978
Connector

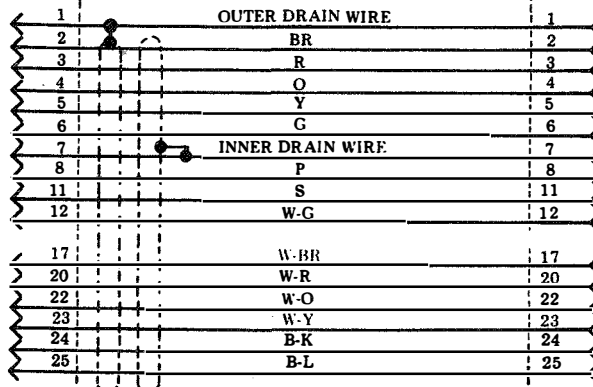

PART 3 -- ROUTINE SERVICING
A. TROUBLE ISOLATION AND CORRECTION

This paragraph provides troubleshooting information including Controller Self-Tests intended to isolate a trouble to either the terminal or to the external communications device. It provides troubleshooting within the terminal to the extent that correction can be accomplished with minimal training required and using the adjustments provided or parts and tools indicated in this manual. See Manual 406 for more detailed troubleshooting.

Trouble analysis is presented in the form of a "20 Questions" routine in the following TROUBLESHOOTING GUIDE. The guide, with questions and yes or no columns, should be used, always starting with the first question and proceeding according to the "yes" or "no" directive.

1. TROUBLESHOOTING GUIDE

QUESTIONS	YES	NO
1. Are any indicators on keyboard lit? (Power available, AC cord plugged in, terminal power switch on, and cover closed.)	Go to 2.	Go to 1a.
1a. Is there any indication of power in the set? (Keyboard lamps flash when KP power is turned on and off, print head indexes to the left, RED lamp on power supply lit, etc.)	Go to 1c.	With power off, check AC fuse F1 (See Page 3-12) If fuse is OK, trouble is in terminal. Replace fuse if blown. Go to 1b.
1b. Do any indicators now light when power is turned on?	Original trouble is corrected.	Trouble is in terminal. Do not replace fuse second time.
1c. Is RED lamp on power supply lit? See Page 3-11 for location.	Check seating of power supply output cable. Check opcon cable plug.	With power off, check F2 fuse on power supply (See Page 3-12.) If fuse is OK, trouble is in terminal.

A. TROUBLE ISOLATION AND CORRECTION (Contd)1. TROUBLESHOOTING GUIDE (Contd)

QUESTION	YES	NO
1c. (Cont)	Trouble is in terminal.	If fuse is blown, check for foreign objects between circuit lands or terminals and replace fuse. Go to 1d.
1d. Does RED lamp on power supply now light when power is turned on?	Original trouble is corrected.	Trouble is in terminal. Do not replace fuse second time.
2. Can any characters be locally generated from the keyboard to the printer?	Go to 3.	Trouble is in terminal.
3. Are any of the following characters substituted in the copy? <div style="text-align: center;"> O ∅ ^ ↑ - ← </div>	Check Page 2-1, <u>A. SWITCH ENABLED OPTIONS, 431.</u>	Go to 4.
4. Are undesired line lengths set when power is applied?	Option switch SPB6 switches 3 and 4 must be off. (See Page 2-1.) Check user programmable options LfBdy and RtBdy for proper values. (Refer to How to Operate Manual.)	Go to 5 (pin or tractor feed). Go to 6 (friction feed).
5. <u>Pin or Tractor Feed</u> Is printed copy properly centered or aligned with edges of paper? (ie, parallel to edge and not printing on fold or form line.)	Go to 6.	Check <u>RIGHT PAPER SPROCKET</u> and <u>PRINTED LINE POSITION</u> adjustments. (Soft roll tractor platen if printing on fold or form line.)
6. Is print density acceptable (including any carbons)?	Go to 7.	Replace ribbon. Check proper density of multicopy paper.

QUESTIONS	YES	NO
7. Can any data be both sent and received on-line?	Go to 8.	Go to 7a.
7a. Does data set provide analog loopback feature?	Place in test mode and go to 7b.	Remove data set cable and install 403378 interface loopback connector (or equivalent*) in teleprinter data set connector, then go to 7c.
7b. With teleprinter in full duplex, SR, terminal on-line mode, is sent data received?	Go to 8.	Remove data set cable and install 403378 interface loopback connector (or equivalent*) in teleprinter data set connector, then go to 7c.
7c. With teleprinter in full duplex, SR, terminal on-line mode, is sent data received?	Go to 8.	Trouble is in teleprinter.
8. Are data messages properly sent and received in terminal on-line mode (both batch and S/R)?	Place in service.	Check user programmable options - Speed StopU, PrTyp, etc. Perform Keyboard Self-Test - see How To Operate manual.

*Go directly to the NO response directive for Step 8 if a loopback arrangement is not available.



403378 INTERFACE LOOPBACK CONNECTOR

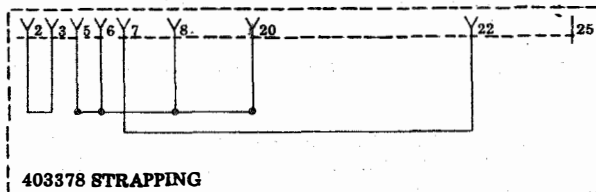

403378 STRAPPING

If test fails, trouble is in terminal.
If test is OK, perform Controller Self-Test - See Page 3-4.
If controller LED is not lit (test fails) trouble is in terminal.
If self-test is OK, trouble is in external communications device or remote terminal. (If interface loopback test was not performed, the trouble may be in either the teleprinter or external communications device.)

A. TROUBLE ISOLATION AND CORRECTION (Contd)2. CONTROLLER SELF-TEST

An LED, located under the thirteenth bustle air vent slot from the left, is used to indicate controller operation and the result of the self-test routine. The round, black test switch actuator is located under the seventeenth bustle air vent slot from the left. Refer to C. COMPONENT LOCATION AND ACCESS, Pages 3-11 and 3-12 and figure below.

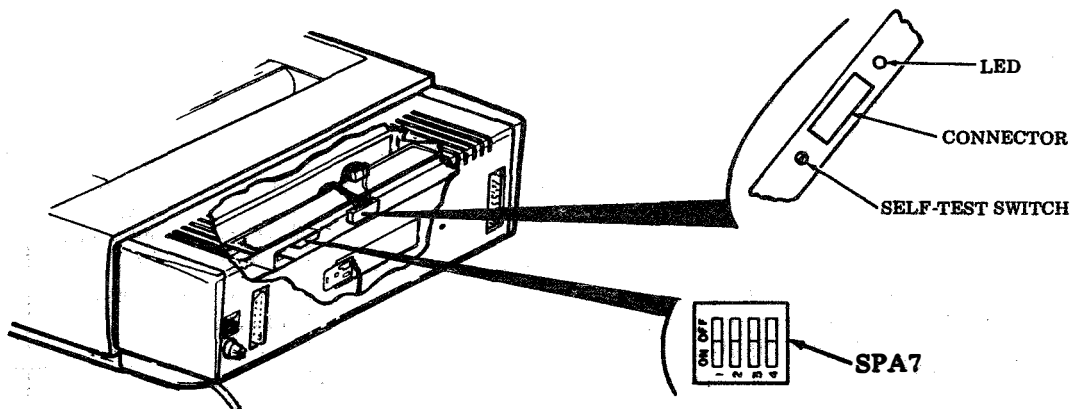

Record SPA7 switch positions and then reach through the air vent slot and place switches in the ON (down) position.

To initiate the test, momentarily depress the controller test switch actuator by reaching through the air vent slot with a small, nonmetallic tool such as an orange stick or a plastic rod. The controller LED is the test status indicator. It will flash periodically during the test (approximately 30 seconds) to indicate the test is in progress. When the test is concluded (all flashing stops) the LED will turn ON indicating that the test passed and normal operation may be resumed.

Place SPA7 switches in their initial positions.

Failure of the controller self-test is indicated if LED is not ON after the test period.

NOTE 1: The controller self-test is independent of the keyboard and the printer.

NOTE 2: Information stored in the volatile memory will be lost when this test is performed.

NOTE 3: Ignore any data that may print or any other printer or keyboard response as a result of this test.

NOTE 4: If the controller LED continues to flash (approximately every seven seconds), the controller test switch may be in its "locked" position. To release the switch, rotate the actuator 1/8-turn counterclockwise.

3. PRINTER LOCAL TEST

The printer local test may be entered by placing SPB6 -- SW5 ON. Refer to COMPONENT LOCATION AND ACCESS Page 3-11 and 3-12. The test should consist of at least 16 lines (4 are shown below). Return SW5 to OFF to stop the test.

```

■ !"#%&'()*+,-./0123456789:;<=>?@ABCDEFGHIJKLNOPQRSTUVWXYZ[\]^_`abcdefghijklmnopqrstuvwxyz{|}~
■ !"#%&'()*+,-./0123456789:;<=>?@ABCDEFGHIJKLNOPQRSTUVWXYZ[\]^_`abcdefghijklmnopqrstuvwxyz{|}~
■ !"#%&'()*+,-./0123456789:;<=>?@ABCDEFGHIJKLNOPQRSTUVWXYZ[\]^_`abcdefghijklmnopqrstuvwxyz{|}~
■ !"#%&'()*+,-./0123456789:;<=>?@ABCDEFGHIJKLNOPQRSTUVWXYZ[\]^_`abcdefghijklmnopqrstuvwxyz{|}~

```

B. PERIODIC CHECKS, LUBRICATION, AND CLEANING

1. GENERAL

This part provides routine servicing procedures for the 43 Teleprinter Tabletop Buffered KSR Station.

Routine servicing should be performed, at the convenience of the customer, at least once a year.

Routine servicing consists of visual checks, lubrication, and cleaning. When performed at routine intervals, the possibility of later troubles will be reduced.

Following the routine servicing, a local and on-line installation checkout should be performed.

2. VISUAL CHECKS

The following areas should be checked for mechanical condition:

- a. Frayed belts on spacing, line feed motors or tractors.
- b. Worn or frayed ribbon
- c. All cable connectors fully seated (Pages 3-11 and 3-12).
- d. Print head cover fully seated.

B. PERIODIC CHECKS, LUBRICATION AND CLEANING (Contd)

3. CLEANING AND APPEARANCE

Examine exterior areas for smudges, dust, etc.

Check proper fit of cover. Replace extremely damaged or discolored cover, housing, bustle, etc.

Exterior cleaning should normally be limited to wiping with a soft cloth moistened with a mild detergent. However, in case of ink stained plastic surfaces, a waterless (nonabrasive) hand cleaner or a lather from abrasive bar soap applied with a cloth should be used.

Interior areas should be examined with the cover opened and accumulations of paper dust or ribbon fragments cleaned by carefully brushing loose material onto a cloth. Ink stains or deposits on interior surfaces, ribbon rollers, platen, etc, can be wiped with a cloth dampened in mineral spirits.

WARNING: DO NOT ALLOW MINERAL SPIRITS OR SOLVENTS TO CONTACT PLASTIC SURFACES.

4. LUBRICATION PROCEDURES

The printer can be lubricated by opening the cabinet cover (and side covers on tractor). Apply lubricant to points as indicated.

The lubrication interval should be 500 operating hours or six months, whichever comes first.

Lubrication should be performed at least once a year.

Excessive lubricant should be removed with a dry, lint-free cloth. The following areas must be kept dry, free of all lubricant: All electrical components, including terminals. All parts normally touched by the operator, including exposed surfaces in ribbon, paper handling areas, and all large flat areas.

The following symbols indicate the quantity of lubricant to be used in a specified area: Symbols 01, 02, 03, etc, refer to 1, 2, 3, etc, drops of oil.

The following list of symbols applies to the lubrication instructions and the type of lubricant to be used:

- O Oil 88970 (1 qt), 88971 (1 gal).
- G-A Apply thin film of 301313 (1-3/4 oz.) or 454641 (14 oz.) grease.
- G-B Apply thin film of Syn-Tech grease (use 430836 tube with grease and 430838 brush).
- G-C Fill with Poly Oil grease (use 430837 injector with grease).
- S Saturate felt oilers, washers, and wicks with oil.
- D Keep dry, no lubricant permitted.

Lubrication Check List: (See Pages 3-8, 3-9 and 3-10)

Lead Screw -- Film of grease over entire threaded portion of lead screw.
 Carriage Wicks -- Saturate with oil (4 places)
 Ribbon Guide Rollers -- 2 drops of oil (2 places)
 Ribbon Rollers -- 2 drops of oil (2 places)
 Ribbon Tension Arm Pivot and Spring -- 2 drops of oil each (4 places)
 Spacing Tension Arm Pivot, Roller and Spring -- 2 drops of oil each (4 places)
 Platen Bearing -- 5 drops of oil each side (2 places)
 Finger Pivots -- 2 drops of oil each side (2 places)
 Paper-Out Arm Pivot -- 2 drops of oil on both pivot points (Pin and tractor feed only).
 Lead Screw Pulley Clip -- Grease between clip and lead screw shaft.
 Pressure Roller Bail Spring -- 2 drops of oil each end (2 places - friction feed and tractor feed only).
 Platen Tray Shaft -- 2 drops of oil each end at the side plates (2 places - friction feed and tractor feed only).
 Pressure Roller Bail -- 2 drops of oil each end at pivot points on each side of bail (2 places - friction feed and tractor feed only).
 All Spring Eyeloops at the Anchor Points -- 1 drop of oil.
 Line Feed Intermediate Gear and Shaft -- Light film of grease (tractor feed only).
 Inner Platen Shaft and Roll Pin -- Light film of grease (tractor feed only).
 Platen Pressure Roller Release Arm Pivot and Working Surface -- Light film of grease (tractor feed only).
 Line Feed Motor Mounting Points -- 1 drop of oil on each mounting point (Pin and friction feed with floating motor).

Carriage and Nut Engaging Surfaces:

- a. Two Nut Drive Arms -- Grease four bearing surfaces.
- b. Nut keying Arm -- Lubricate by packing carriage engaging slot with grease.

Print Head:

- a. Active Armatures and Outer Pole Plate -- Grease at the upper pivot area as well as the lower locator area (9 places).
- b. Print Wire Well Area -- Completely fill with grease.

Tractor:

- a. Spline Shaft -- 1 drop of oil on each bearing (2 places).
- b. Margin Adjust Wheel -- Oil light coating on threads.
- c. Release Lever Pivots -- 1 drop of oil on each pivot (2 places).
- d. Idler Gear Shaft -- Light film of grease.
- e. Gear Surfaces -- Light film of grease on drive surfaces.

B. PERIODIC CHECKS, LUBRICATION AND CLEANING (Contd)

5. LUBRICATION POINTS

Pin and Friction Feed

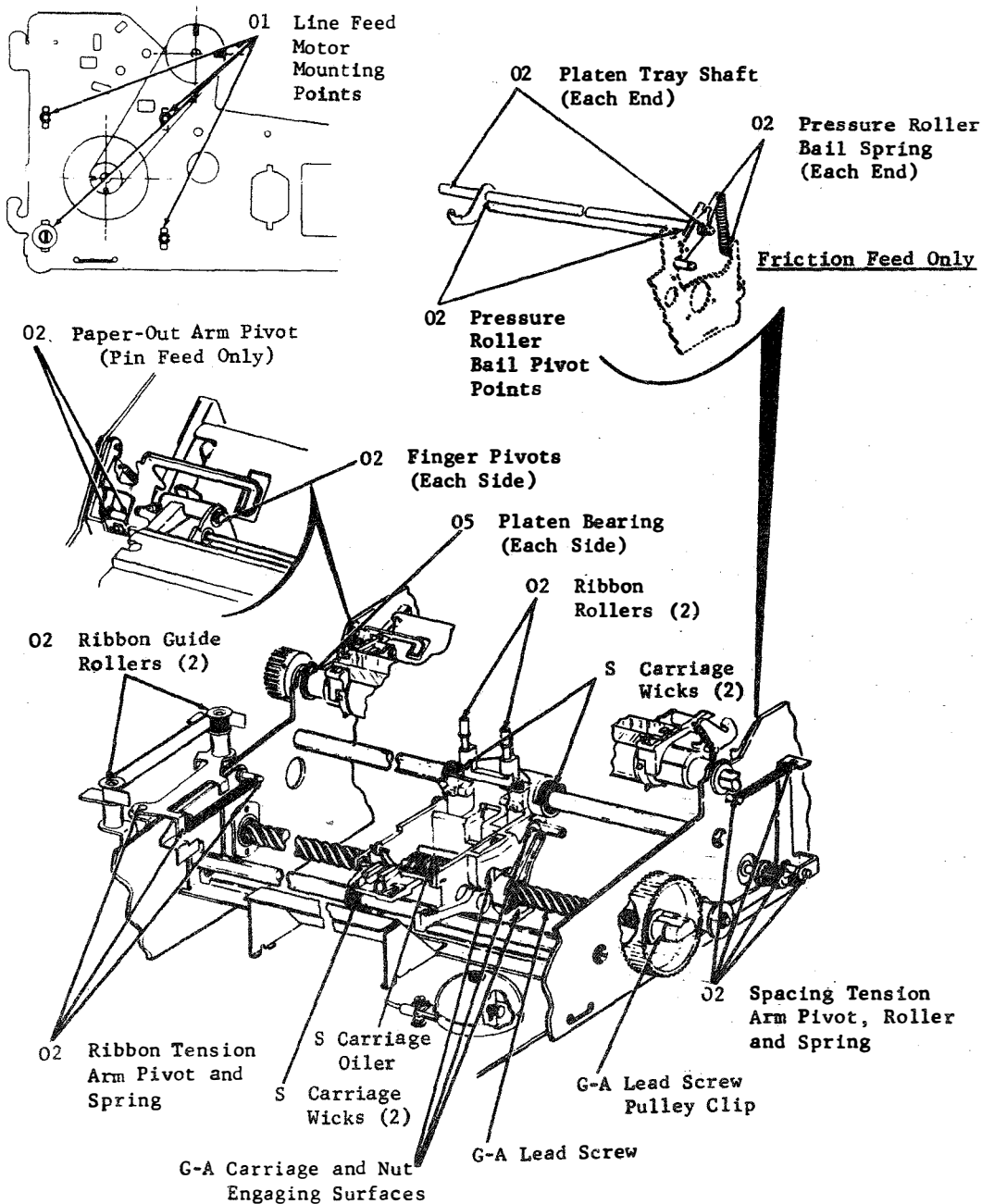

Print Head

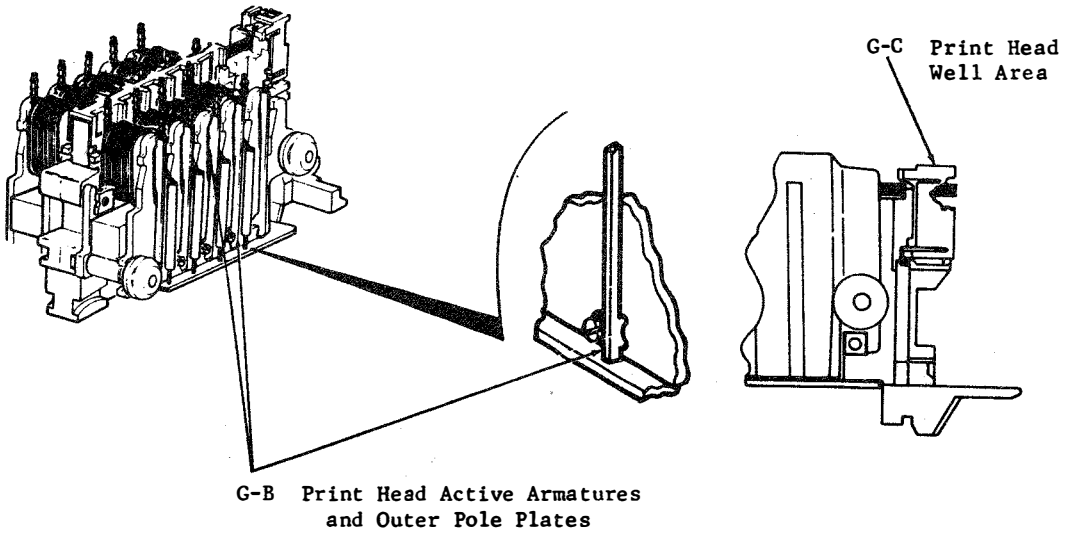

Tractor

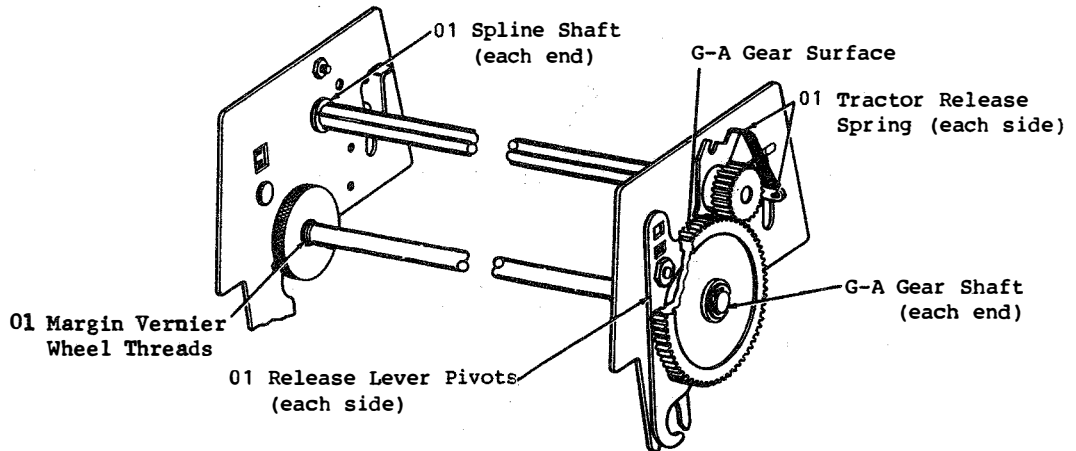

B. PERIODIC CHECKS, LUBRICATION AND CLEANING (Contd)

5. LUBRICATION POINTS (Contd)

Tractor Feed

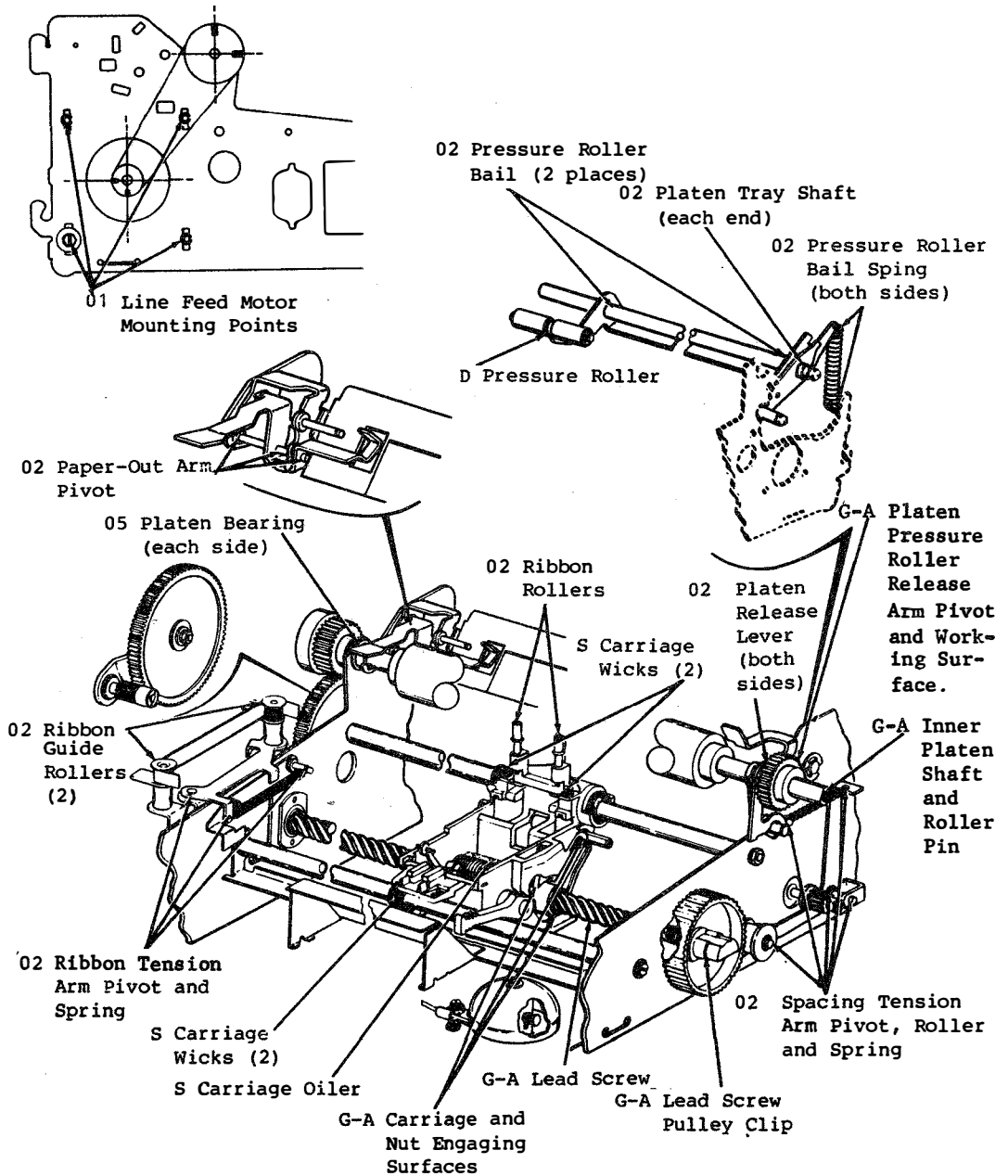

C. COMPONENT LOCATION AND ACCESS

1. KEYBOARD, PRINTER, LOGIC CARD, SWITCHES AND INDICATORS

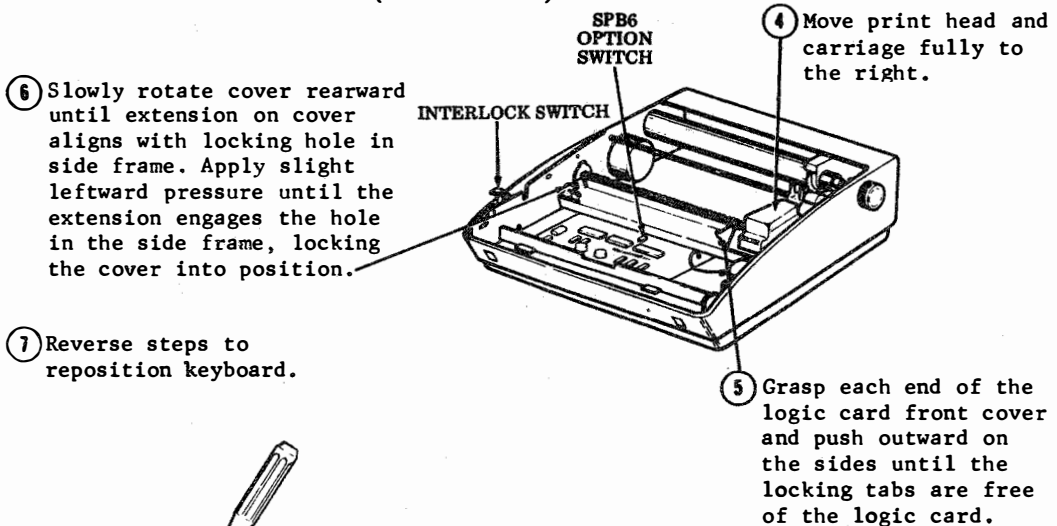
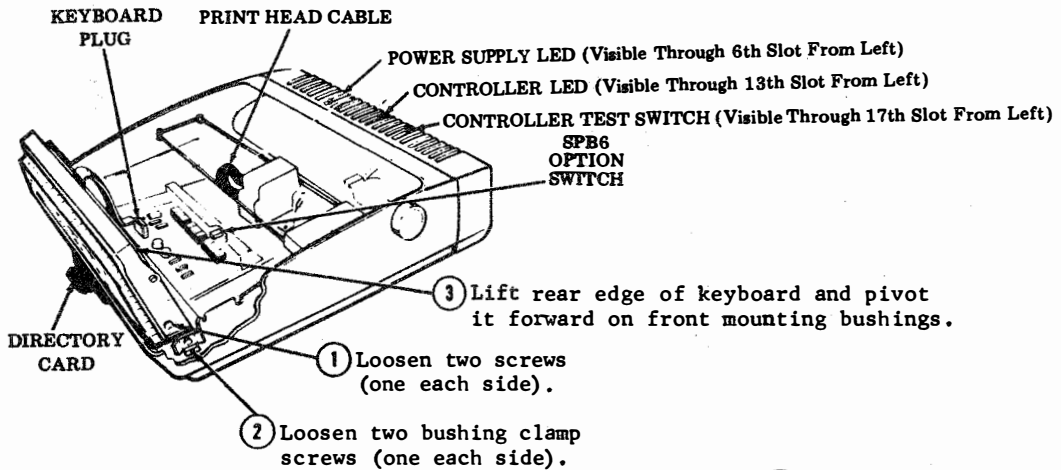

⑦ Reverse steps to reposition keyboard.

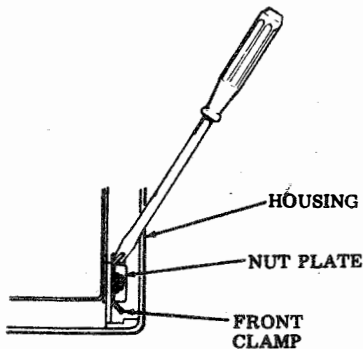

NOTE: When repositioning keyboard, insert a screwdriver into the square hole in the nut plate and gently twist (or pry) the screwdriver with enough force to draw the assembly forward.

CAUTION: DO NOT OVERTWIST THE SCREWDRIVER.

Tighten the clamp screws.

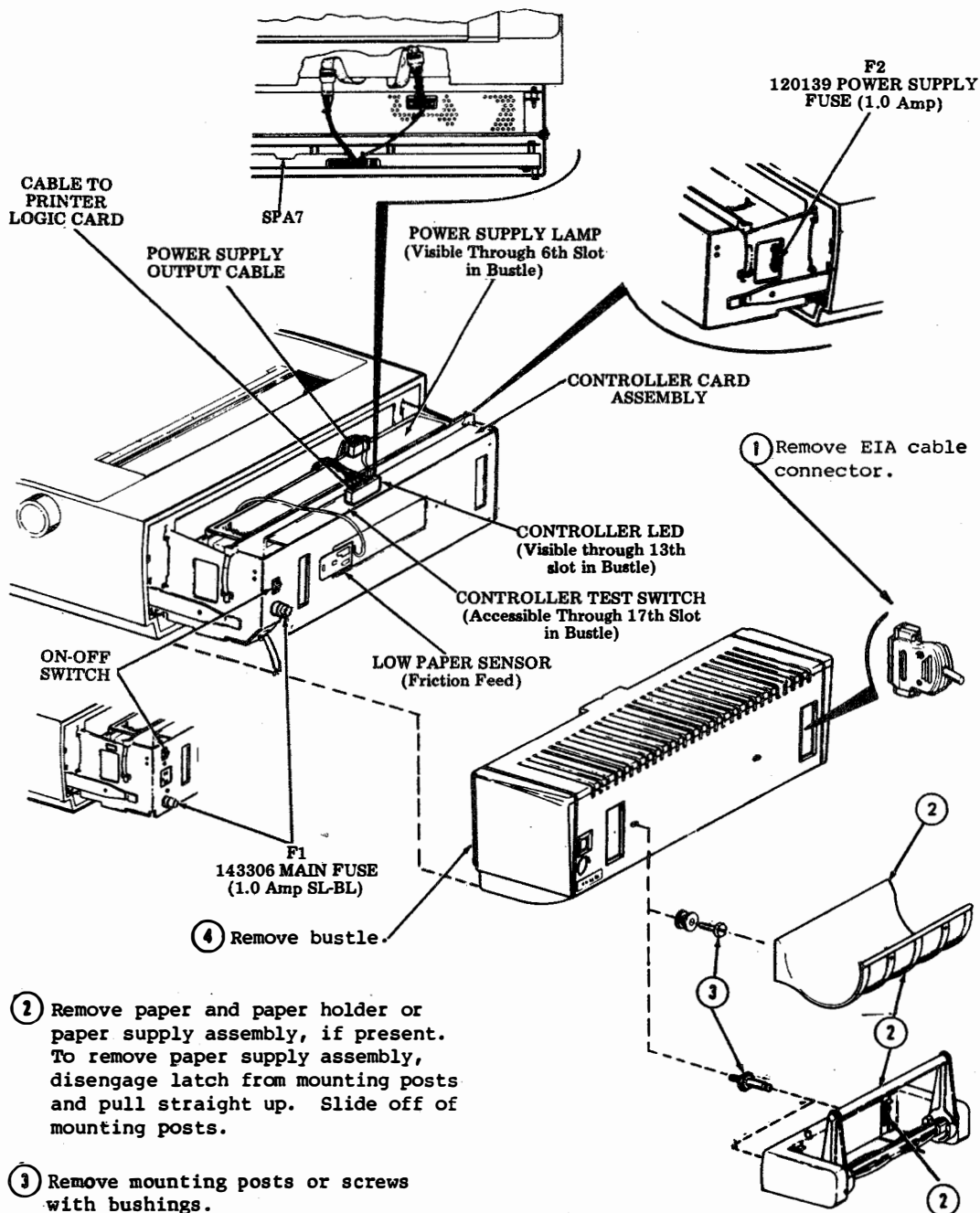
C. COMPONENT LOCATION AND ACCESS (Contd)2. POWER SUPPLY LAMP AND FUSE, CONTROLLER CABLE, LED AND TEST SWITCH

3. POWER SUPPLY 115/230 V OPTION STRAP

a. To remove Power Supply:

Perform 2. POWER SUPPLY LAMP AND FUSE, CONTROLLER CABLE, LED AND TEST SWITCH, steps 1 through 4.

Grasp power supply at each end; lift up until ac plug can be removed. Remove ac plug and continue lifting up and away from low paper sensor cable (if present) to remove power supply.

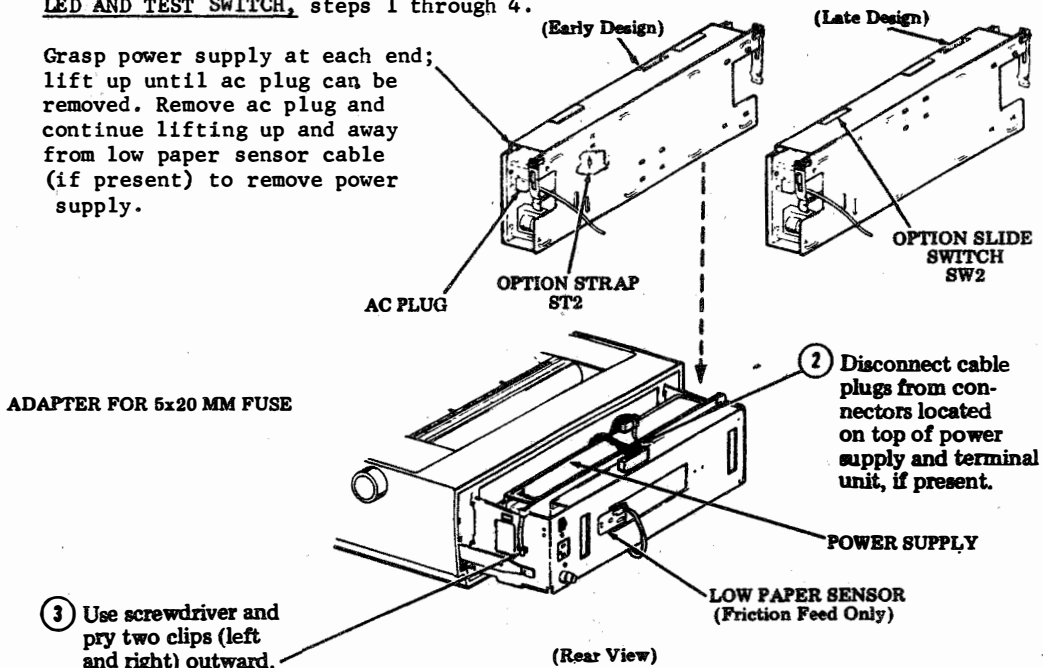

To remove 410703 circuit card from 430760 power supply:

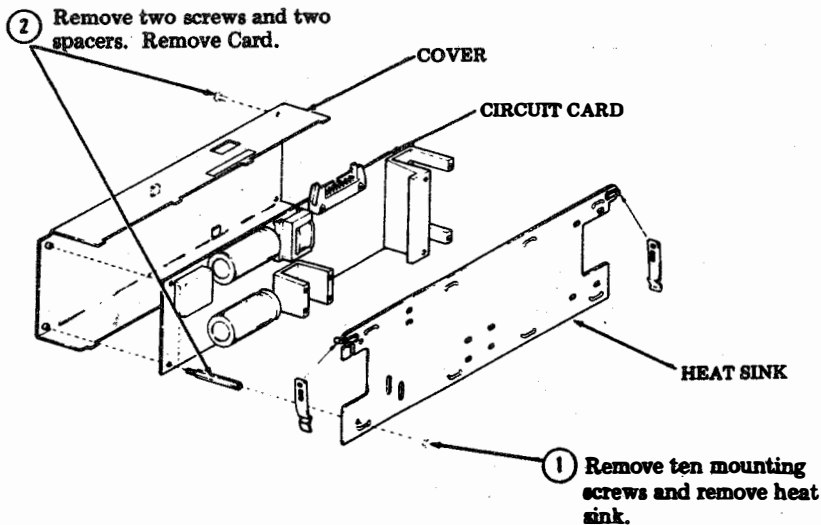

C. COMPONENT LOCATION AND ACCESS (Contd)3. POWER SUPPLY 115/230 Vac OPTION (Contd)

To change the option from 230 Vac to 115 Vac (410703 circuit card)

The 410703 circuit card is shown optioned for 230 Vac. To option the 410703 circuit card for 115 Vac, remove strap ST2 from its 230 Vac location and solder it into the 115 Vac position. Mark the power supply¹ to show the option change.

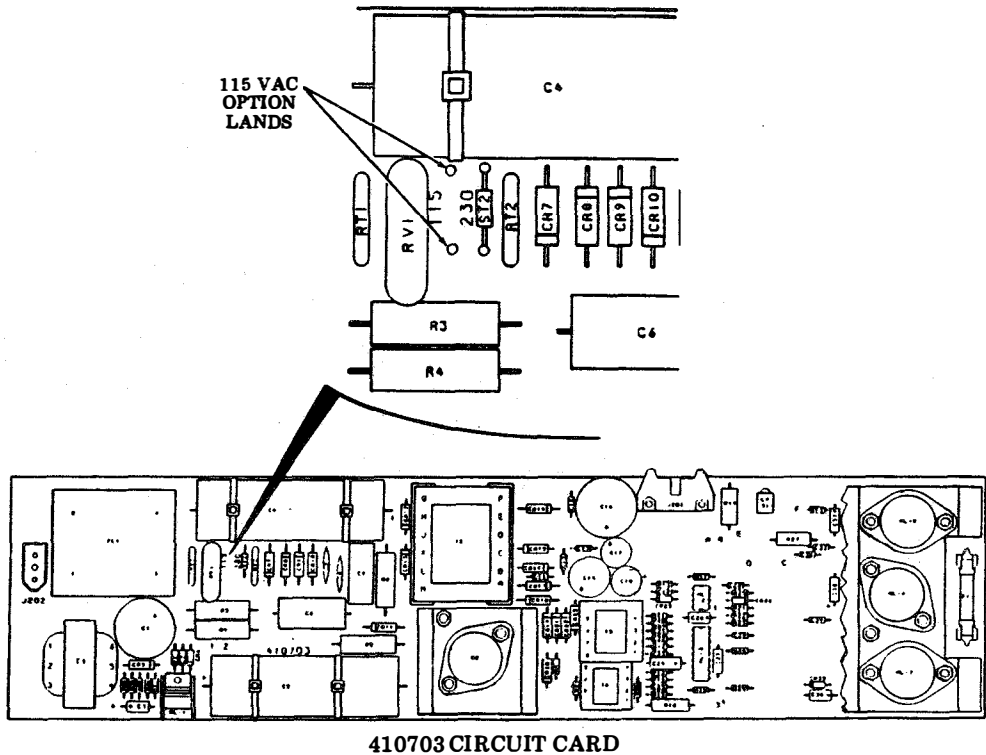

To change the option from 230 Vac to 115 Vac (410704 circuit card) operate the slide switch on top of the power supply card to the 115 V position.

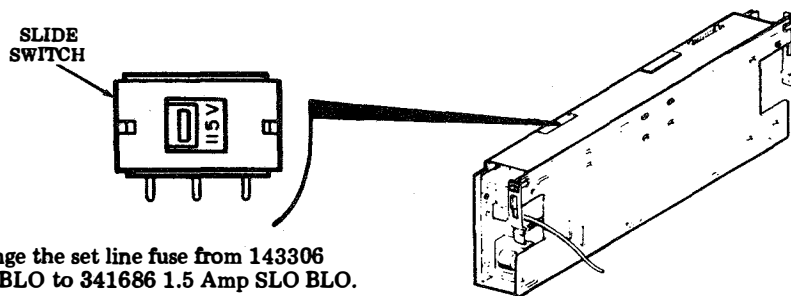

Note: Change the set line fuse from 143306
1.0 Amp SL BLO to 341686 1.5 Amp SLO BLO.

4. TRACTOR

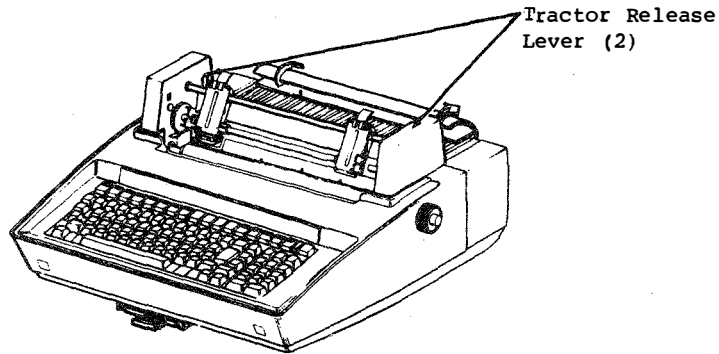

- ① To remove tractor, press down both tractor release levers as you lift the entire tractor mechanism. To replace, press tractor release levers down and seat in position.
- ② To gain access to the mechanism on the right and left side plates, first remove the tractor from the teleprinter, then depress the cover latches (at the lower corners of the side plate) and swing cover out and lift to remove. To replace the covers, seat the top edge of the cover on the top of the side plate and snap the lower portion in position.

D. ADJUSTMENTS

1. RIGHT PAPER SPROCKET (Early design platens with adjustable sprockets)

Requirement

The right sprocket should be biased against the collar of the platen hub and the pins should be in line with the pins of the left sprocket.

To Adjust

Loosen setscrews and position right sprocket to meet requirement.

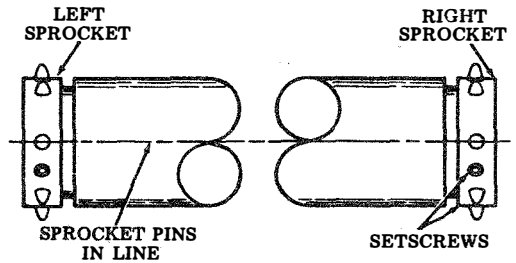

2. PLATEN ENDPLAY (Friction and Pin Feed)

The following two requirements must be met:

(1) Requirement

Platen Endplay -- With the platen biased to the right, there should be

Min Some---Max 0.008 inch

clearance between the left bearing and the platen hub, at the closest point, and

Max 0.030 inch

between the left bearing and the pulley at the closest point.

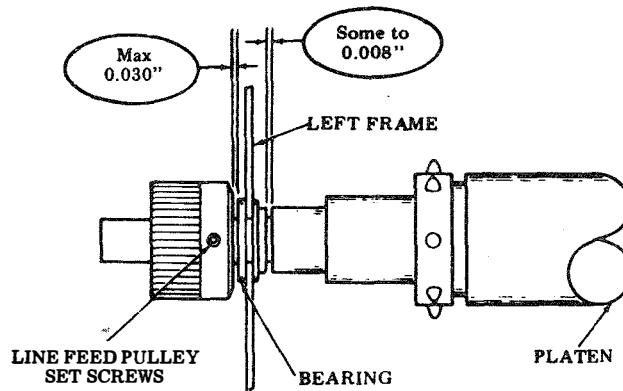

3. PRINTED LINE POSITION (Pin Feed Only)

(2) Requirement

Printed line Position -- The lower edge of a typed line of M characters should be $1/32 \pm 1/64$ inch above a horizontal line located by any of the following methods:

1. A line drawn between the lower edges of two opposite sprocket holes.
2. A preprinted line on the form the same as in 1. above or in $1/6$ inch multiples.
3. A fold midway between two sprocket holes on fanfold paper.

(Power must be on line feed motor for this adjustment.)

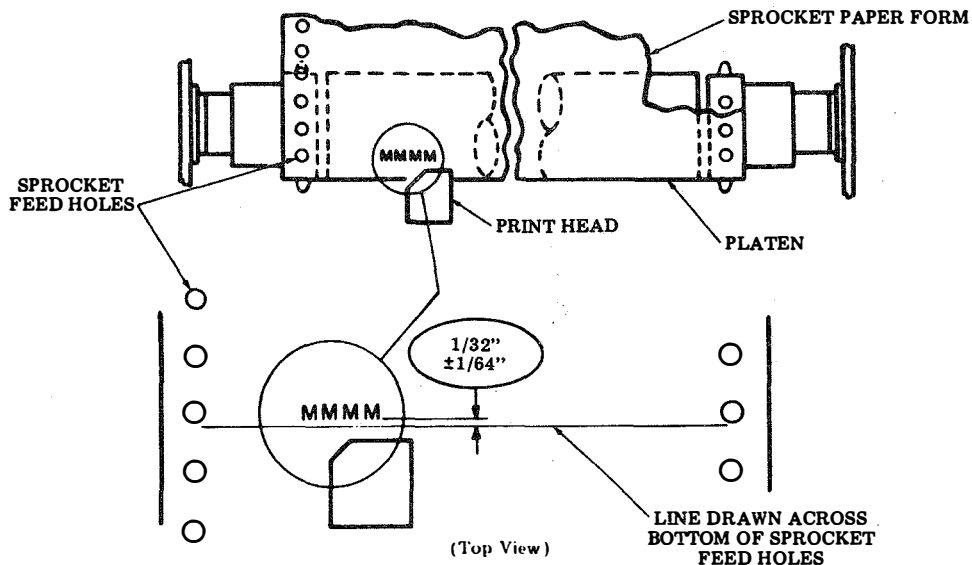
**To Adjust**

Loosen the line feed sprocket (at platen) set screws and position. Print the character "M" across the line and check (2) Requirement. If necessary, loosen setscrew on right sprocket to meet alignment requirement (early design).

D. ADJUSTMENTS (Contd)4. PRINTED LINE POSITION (Tractor Feed Only)

Requirement

The printed line should not vary more than ± 0.031 from an arbitrary horizontal reference line (lined paper) when a line is drawn even with the bottom of the first and last character of a 10 inch long printed line.

To Adjust

Remove the left end cover, loosen the shoulder nut and position latch to meet the requirement. Retighten the shoulder nut and recheck the requirement.

NOTE: It is recommended that a single character such as M be repeated on the entire page for the above adjustment if done on a printer.

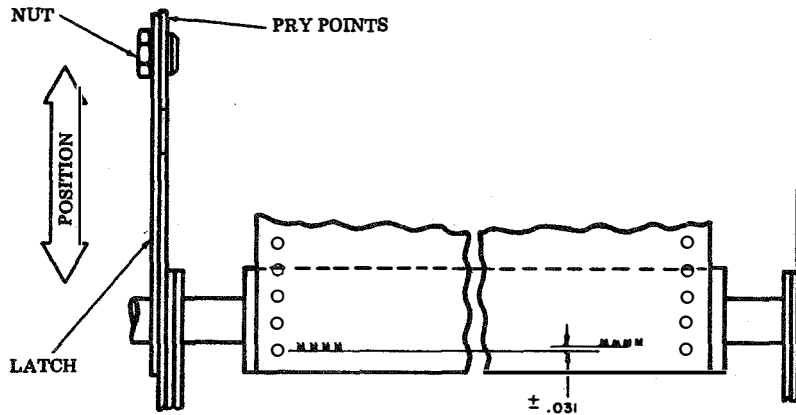

5. IDLER GEAR TO PRINTER PLATEN GEAR (Tractor Feed Only)**Requirement**

With the tractor mechanism installed on the printer (latched on the platen bushings) there should be minimum backlash between the platen drive gear and the tractor idler gear.

To Adjust

Remove the end cover from the right tractor frame, loosen the release lever pivot shoulder nut, and use the pry points to make the adjustment. Retighten the shoulder nut and rotate the platen with the line feed motor declutched (soft roll) to insure the mechanism rotates freely and there is no binding. Remake the adjustment, if necessary.

NOTE: This adjustment may be made on a fixture which simulates the printer.

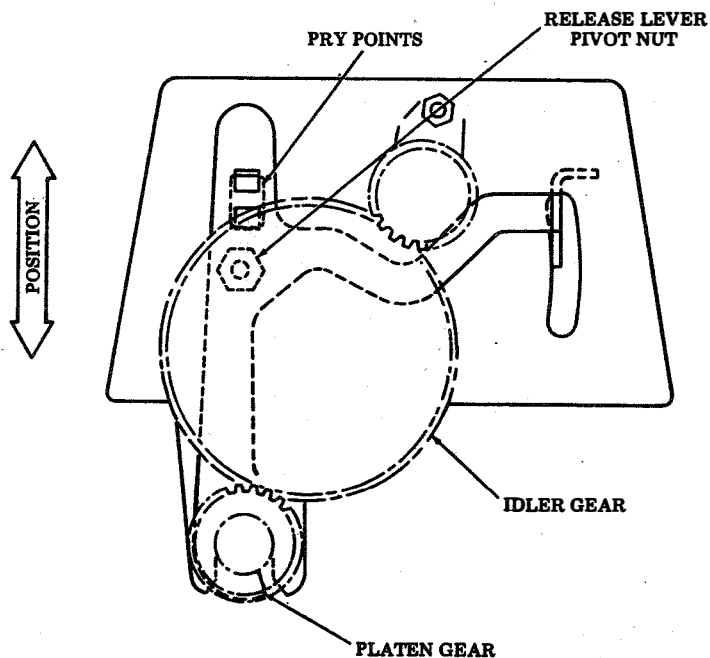

6. PAPER SENSING ARM (Friction Feed Only)

Requirement

- (1) Preliminary--Under normal operation, the alarm indicator shall light when approximately a two inch diameter of paper (40 feet) remains on the spindle.
- (2) Final — May be set at more or less than a two inch diameter as long as alarm indicator lights before paper runs out and sensing arm does not touch full roll of paper when depressed downward to the end of its travel.

To Check

When the low paper sensing arm is depressed downward to the end of its travel and then allowed to slowly return upward, the alarm indicator shall light when there is approximately a two inch diameter (40 feet) of paper left on the spindle.

To Adjust

Grasp the sensing arm support where the wire arm is attached and bend the sensing arm.

Caution: This adjustment is set at the factory and normally does not require readjustment. If the adjustment is performed, care should be taken not to bend the sensing arm support. Check to see that the sensor arm moves through its entire range without binding.

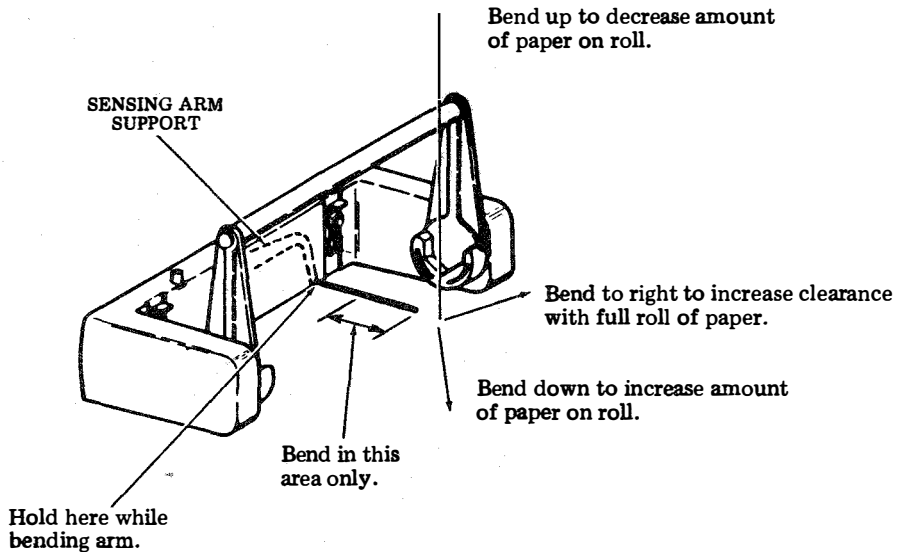

PART 4 -- ASSOCIATED DOCUMENTS AND ACCESSORIESDOCUMENTATION LISTINGSERVICE MANUALSMANUAL NO.DESCRIPTION

406 -- 43 Teleprinter, Buffered KSR Tabletop and Pedestal Based

REPAIR MANUALSMANUAL NO.DESCRIPTION

385 -- Circuit Diagrams for Components used in 42/43 and 45-30 CPS Character Printer Terminals and Associated Units
 513 -- Standard Serial Interface Technical Reference
 522 -- TTL and SSI Logic Cards used in 42/43 and 45-30 CPS Character Printers
 523 -- Power Supplies used in 42/43 and 45-30 CPS Character Printer Terminals
 530 -- SSI Keyboards used in 42/43 Buffered Terminals
 533 -- Parts -- Enclosures, Paper Handling and Miscellaneous Accessories used with 42/43 and 45-30 CPS Character Printers
 534 -- Interfaces, Controllers and Modification Kit Circuit Cards associated with 42/43 Terminals (includes AB, SCU, and brief repair of non-pedestal controllers)
 539 -- 42/43 and 45/30 CPS Character Printer Mechanisms

SHOP MANUAL

478 -- Tabletop Buffered Controllers used in 42/43 Terminals

ACCESSORIES

The following tabletop 43 buffered terminal accessories are available to the customer.

<u>Accessory</u>	<u>Part No.</u>	<u>Specification No.</u>
Pedestal	430311	51006S
Copyholder	430310	50994S
Modification Kit to add AC Distribution to the KSR		
Pedestal	430911	50990S
Paper Winder	430400	51035S

The above parts may be installed following the instruction furnished with each accessory.

Teletype Corporation

Product Service The Complete Resource

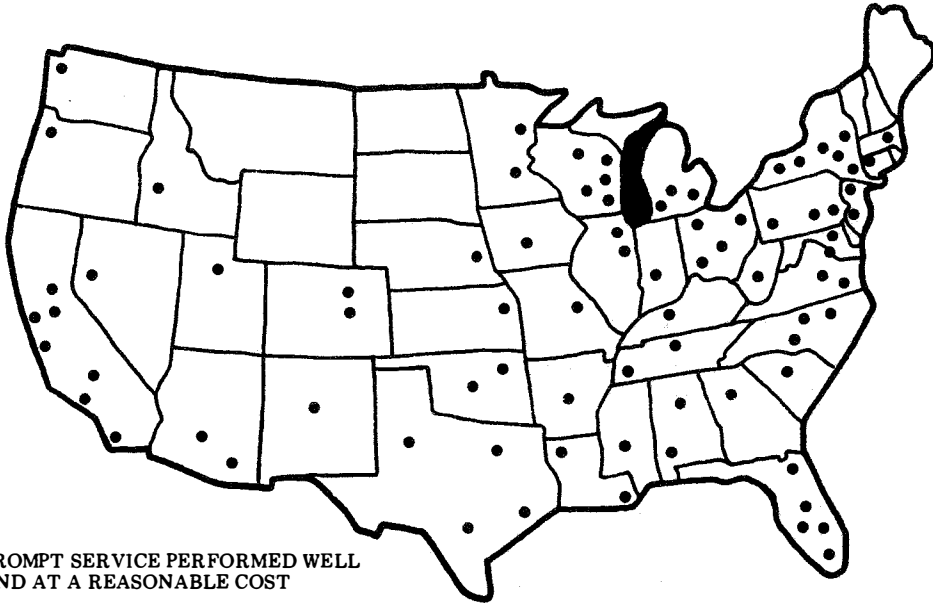

**PROMPT SERVICE PERFORMED WELL
AND AT A REASONABLE COST**

Even the best equipment can fail at some time. When failures occur, you want prompt service, because down time is expensive. You want service performed well -- and at a reasonable cost. With Teletype® Product Service Centers located throughout the United States and Canada, and our National Central Dispatch System available around the clock, every day of the year, you know we rate customer service as our primary goal.

A TOTAL SUPPORT EFFORT

Our service representatives are professional, employed and trained by Teletype Corporation. They know our equipment inside out, and can locate and repair problems quickly and effectively. These skilled technicians are backed by an array of sophisticated test equipment, a multi-million dollar parts inventory, and full engineering support. Only the manufacturer of equipment being serviced can offer this total support effort . . . Teletype Corporation Product Service . . . the complete resource.

NATIONAL SERVICE NETWORK

Albany	Greensboro	Orange County
Albuquerque	Harrisburg	Orlando
Appleton	Hartford	Philadelphia
Atlanta	Houston	Phoenix
Baltimore	Indianapolis	Pittsburgh
Birmingham	Jackson	Portland
Boise	Jacksonville	Reno
Boston	Kalamazoo	Richmond
Buffalo	Kansas City	Rochester
Charleston	Lansing	Sacramento
Charlotte	Little Rock	Salt Lake City
Chicago	Long Island	San Antonio
Cincinnati	Los Angeles	San Diego
Cleveland	Louisville	Santa Clara
Colorado Springs	Lubbock	Seattle
Columbia	Madison	Shreveport
Columbus	Memphis	St. Louis
Dallas	Miami	Syracuse
Decatur	Milwaukee	Tampa
Denver	Minneapolis	Toledo
Des Moines	Mobile	Toronto
Detroit	Nashville	Tucson
Duluth	New Orleans	Tulsa
Durham	New York	Ventura
Eau Claire	Norfolk	Washington
Edison	Oakland	Wausau
Fairfield	Oklahoma City	
Fort Lauderdale	Omaha	

Call Toll Free 800/323-4226

In Illinois 800/942-4192

In Canada, call 416/745-9474



Teletype Corporation

5555 Touhy Avenue, Skokie, Illinois 60077
Telephone: (312) 982-2000

MANUAL 451
Issue 3, December 1982