

MANUAL 347
Issue 1, September 1973
(Revised, December 1973)

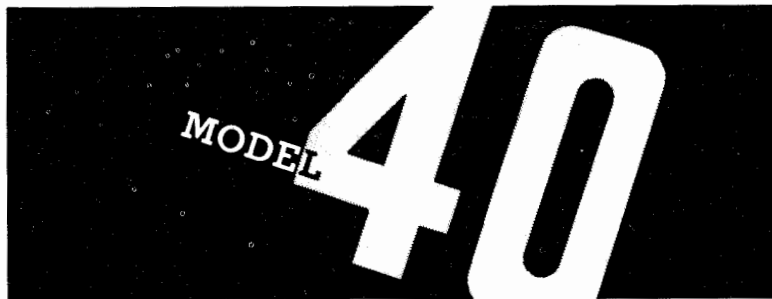

INSTALLATION & SERVICING MANUAL

© 1973 by Teletype Corporation
All rights reserved
Printed in U.S.A.



MODEL 40

INDEX TO FIELD INSTALLATION & SERVICING MANUAL

A.	<u>INTRODUCTION</u>	4
	1. General	4
	2. Identification	6
	3. Field Options	14
	4. Interfacing	28
	5. Technical Data	29
	6. Tools and Supplies	29A
	7. Test Facilities (PSTS and Test Centers).	30
	8. Definition of Terms	31
	9. Performance Reporting and Service Assistance	34A
B.	<u>INSTALLATION</u>	35
	1. Preparation for Installation of Set	35
	2. Activating Options and Modifications	36
	3. Assembly and Internal Connections (Cable Routing)	49
	4. Interface Connections and Suggested Data Set Locations	55
	5. Terminal Placement and Leveling	60
	6. Listing of Options Feature and Modifications	61
C.	<u>OPERATIONAL CHECKOUT FOR KSR AND RO TERMINALS OVER "DATAPHONE*" OR EQUIVALENT MODEMS</u>	62
	Index	62
	1. General	63
	2. Brief Checkout	64
	3. Complete Checkout	68

*Registered Trademark of AT&TCo.

D.	<u>TROUBLE ISOLATION</u>	109
1.	General	109
2.	Trouble Analysis	110
	a. 20 Questions	110
	b. Power Supply	111
	c. Monitor	112
	d. EIA Controller (Not Full Editing)	114
	e. EIA Controller (Full Editing)**	
	f. RO Controller	116
	g. PTI Controller	117
	h. KSR Operator Console	118
3.	Testing	121
	a. Operator Console	121
	b. Display Logic	122
	c. RO Controller**	
	d. PTI Controller**	
	e. Printer	124
	f. Data Set and Line	124A

Note: Asterisked (**)titles indicate not present in this issue.

E.	<u>COMPONENT IDENTIFICATION</u>	125
	General	125
	Figures One Through Fifteen	126
	Numerical Listing	140A
F.	<u>COMPONENT ACCESS</u>	141
1.	Component Replacement	141
	a. Monitor	141
	b. Electronics Package	145
	c. Printer	147
	d. Operator Console	150
2.	Test Switches, Indicators, and Fuses	155
3.	Conversions	156
	a. Electronic Package	156
	b. Operator Console	158

G.	<u>ADJUSTMENTS</u>	160
	1. Electrical	160
	2. Mechanical	165
H.	<u>SERVICING</u>	166
	1. General	166
	2. Schematic Wiring Diagram	167
	3. Routine Lubrication	169
	4. Visual Checks	174
	5. Cleaning	175

● Installation assistance, trouble repair, and replacement parts are available on an exchange and repair basis from the following Regional Teletype Product Service Centers (additional parts used for spares may be ordered from Teletype Corporation Service Parts Division).

Teletype Corporation
 General Offices
 5555 Touhy Ave
 Skokie, Illinois 60076
 phone: 312 982-2000

Chicago
 9930 Derby Lane
 Westchester, Illinois 60153
 phone: 312 345-7920

Boston
 51 New York Ave
 Framingham, Massachusetts 02701
 phone: 617 879-6000

Los Angeles
 5720 E. Washington Blvd
 City of Commerce, California 90022
 phone: 213 724-5051

New York
 140 Sylvan Ave
 Englewood Cliffs, New Jersey 07632
 phone: 201 947-7300

Washington D.C.
 1800 N. Kent St.
 Arlington, Virginia 22209
 phone: 703 522-7118



A. INTRODUCTION

A. INTRODUCTION

1. General

- This manual covers the Model 40 terminal and suggested station arrangements shown in Paragraph 2. Identification.
- It provides the information, as indicated in the index, necessary to identify the type of terminal and its feature variations, install, checkout, maintain and, if necessary, correct operational difficulties.
- A thorough review of this manual or an equivalent training course should be completed, in addition to a knowledge of supplementary information, before installation or servicing of M-40 equipment is undertaken.
- Supplementary information can be found in the How to Operate Manual 346 that is included with each M-40 terminal.
- Troubles isolated to the data modem, customer lines or associated systems are not analyzed in this manual (nor are the replaceable components shown). Switched network troubles are referred to the responsible equipment manufacturer for investigation.
- The routine servicing specified for a Model 40 terminal equipped with a printer should be performed at the customer's convenience.

CAUTION: NORMAL CARE SHOULD BE EXERCISED IN THE AREA OF THE CRT PICTURE TUBE TO AVOID BREAKAGE WHEN SERVICING THE MONITOR WITH ITS COVER REMOVED. ALL POWER TO THE SET SHOULD BE TURNED OFF (AC POWER CORD DISCONNECTED) WHEN ANY COMPONENTS ARE REPLACED, HOWEVER, WHEN ALIGNMENT ADJUSTMENTS ARE PERFORMED, POWER MUST BE ON. IT IS RECOMMENDED THAT SAFETY GLASSES BE WORN WHENEVER THE MONITOR COVERS ARE REMOVED.

- The correction of troubles is based on the replacement of defective components, therefore, the components shown in this manual applicable to the set should be readily available from Teletype Regional Product Service Centers. If a customer is to maintain his M-40 terminals, a carrying case to facilitate storage and transportation of smaller components is available, TP341910.
- In order to facilitate correction of troubles on the initial visit of a trouble call, customer assistance is sought in isolating trouble. Replacement components that may be required for repair can then be determined before a repairman is dispatched to the customer premises by the Teletype Product Service Center.
- The section on trouble isolation in this manual and, to a limited extent in the Operators Manual), provides information on when and how to utilize the test switches and indicators provided in the design of the M-40 terminal (see Page 155).

A. INTRODUCTION (Continued)

1. General (Continued)

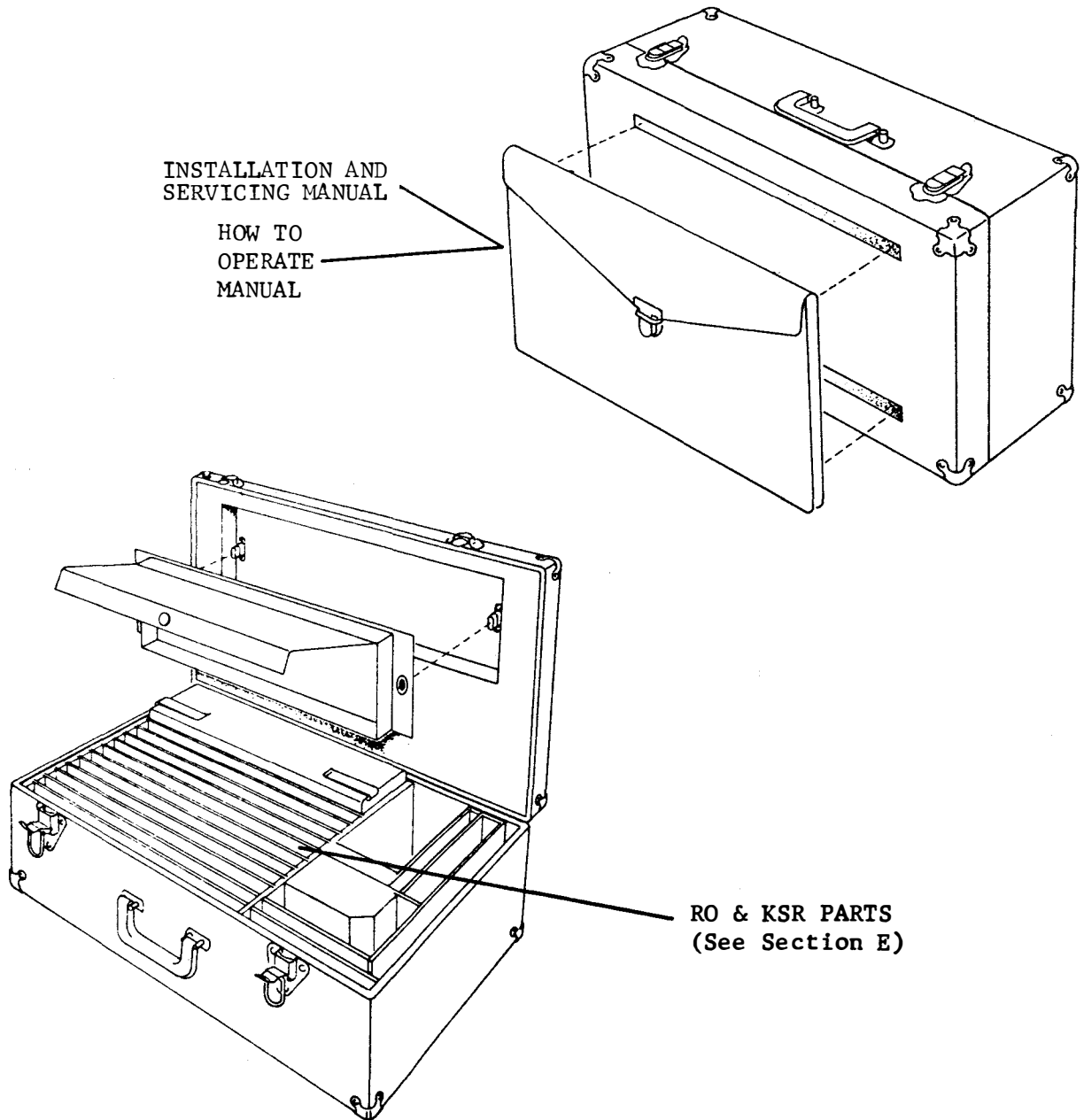



A. INTRODUCTION (Continued)

1. General (Continued)

- Before proceeding with installation, checkout or servicing a review of the features and field options descriptions and records should be made to determine which options, if any, should be changed from the way they were furnished by the factory, were applied at a service center or during earlier service applications.
- The "Feature and Option" record for the terminal should be maintained and attached to the equipment to facilitate checkout or operation.

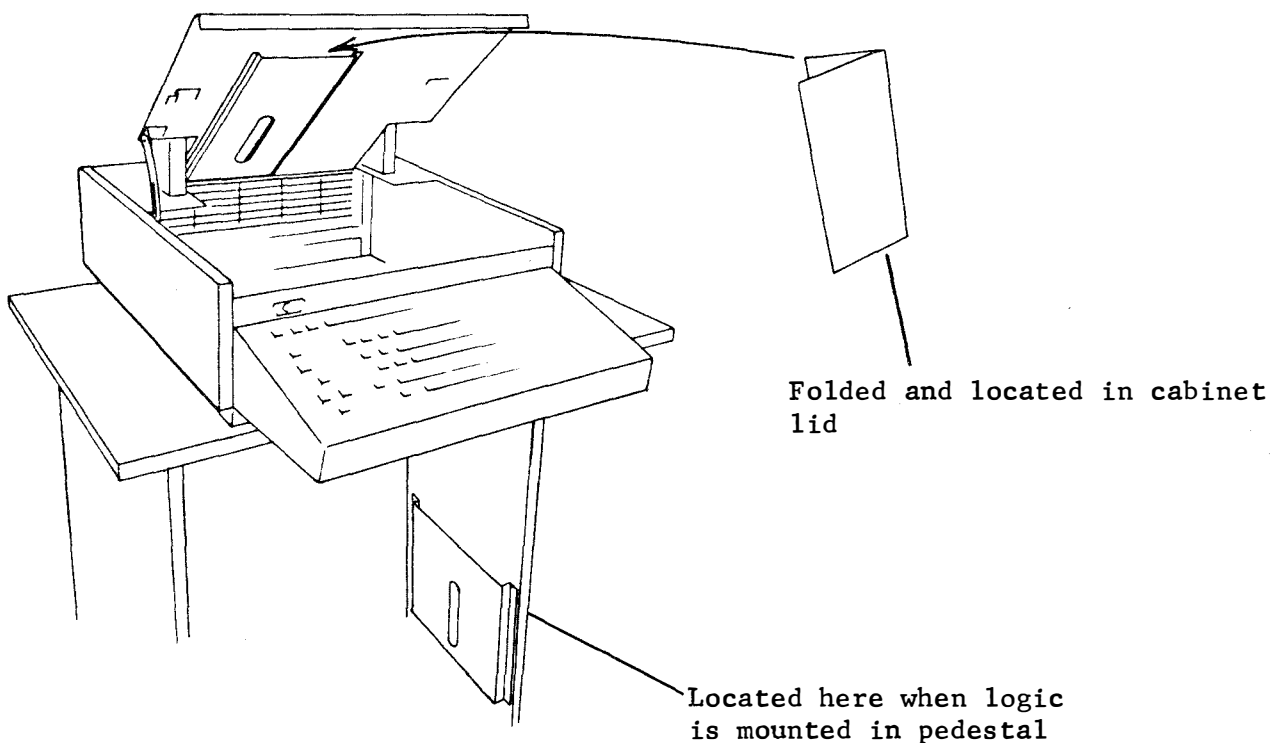

- Conversion information to change features in the field is not provided in this manual except to convert replacement components when correcting a trouble by substitution thereby retaining the original features in the repaired terminal. For information to add or change the features originally ordered, refer to Teletype Corporation Sales Engineering.

A. INTRODUCTION (Continued)

2. Identification

- Identification of the Model 40 terminal and its features are important to a service center or the customer. Knowing what features are provided and how those features are programmed to operate provide the basic understanding necessary for installation, operational checkout, or "in the field" service call routines. Several methods are presented in the following paragraphs for determining terminal features and programming.
- Features included in a terminal can be identified by observing if certain keytops are provided on the operator console, or if a certain type or quantity of printed circuit boards are present in the display controller and display logic circuitry. Features can be determined using the Standard Feature and the Add-On Feature listing. See Pages 11 through 13.
- Teletype Product Service Center or customer programming on this terminal must be recorded on the Feature and Option Record, tear out from page 61 a. Features, options, or special notations must be recorded by checking on the variable number (i.e. option 17 d. 78 for R.H. MARGIN) in the appropriate square on the tear out sheet, which should be removed from the manual and inserted in the slot inside of the cover on the Logic module. See Page 5.
- TELETYPE® Standard Parallel Terminal Interface (PTI) terminals may also be equipped with the external mode control 410678 circuit card (2 interface cables). A PTI terminal connects directly to a terminal control device or similar equivalent signaling input/output data processing equipment.
- On terminals used in switched network applications, the Bell System data set shown, or its equivalent, may be a telephone set with an exclusion key instead of the DATA & TALK keys. The TEST key is located under the pedestal and there is no AUTO answer key as indicated in the checkout procedures.
- References in this manual to TELETYPE® Standard Serial Interface (SSI) describe input/output signaling characteristics for devices using high speed SSI signals.

- A. INTRODUCTION (Continued)
- 2. Identification (Continued)
 - a. Model 40 Terminal for Parallel Interface Applications

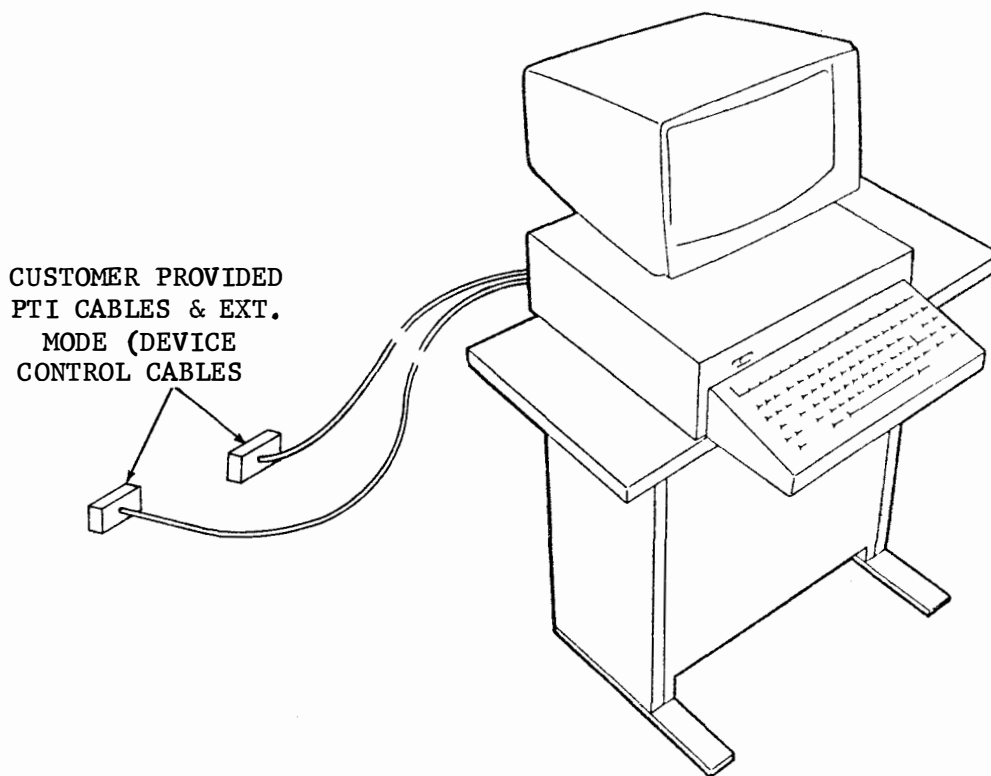

40 KSR (KD) w/o Data Set

- A. INTRODUCTION (Continued)
- 2. Identification (Continued)
- b. Model 40 Terminals Used in Switched Network Applications

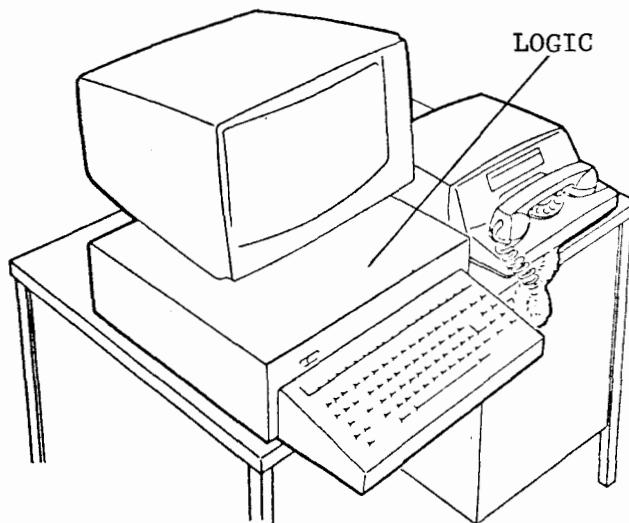

40 KSR (KD) w/Data Set
(Desk or Table Top Version)

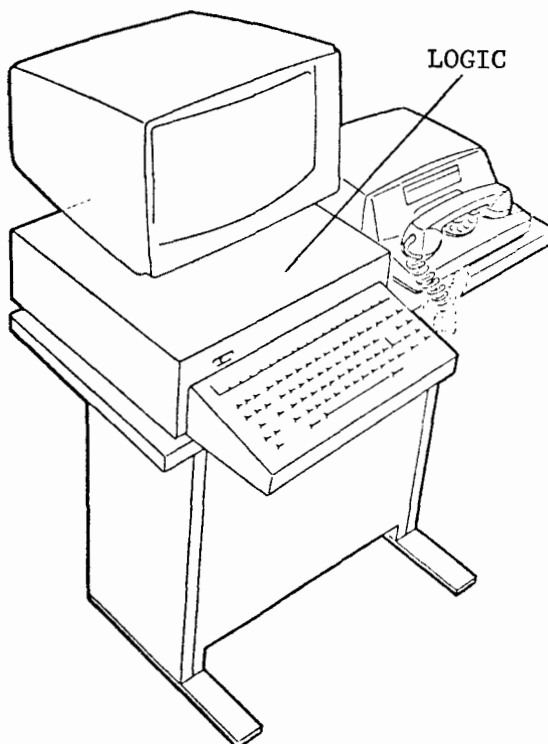

40 KSR (KD) w/Data Set
(Pedestal Mounted)

A. INTRODUCTION (Continued)

2. Identification (Continued)

b. Model 40 Terminals Used in Switched Network Applications (Continued)

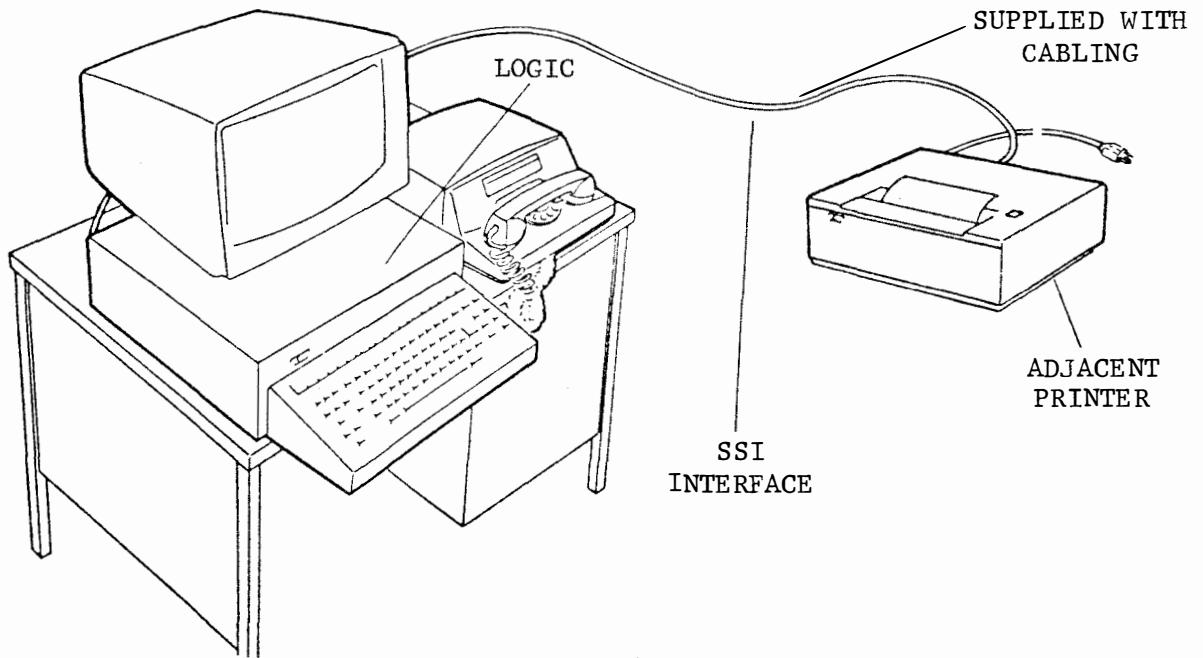

40 KSR (KDP) w/Data Set
(Desk or Table Top Version)

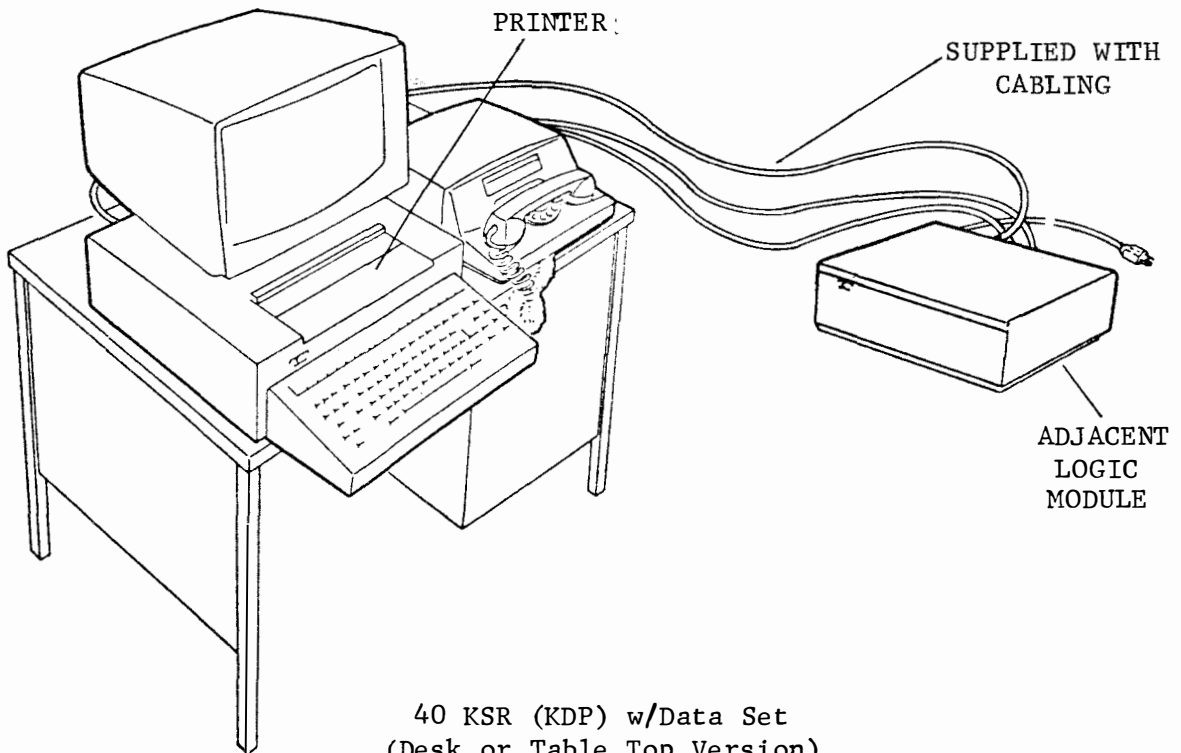

40 KSR (KDP) w/Data Set
(Desk or Table Top Version)

- A. INTRODUCTION (Continued)
- 2. Identification (Continued)
 - b. Model 40 Terminals Used in Switched Network Applications (Continued)

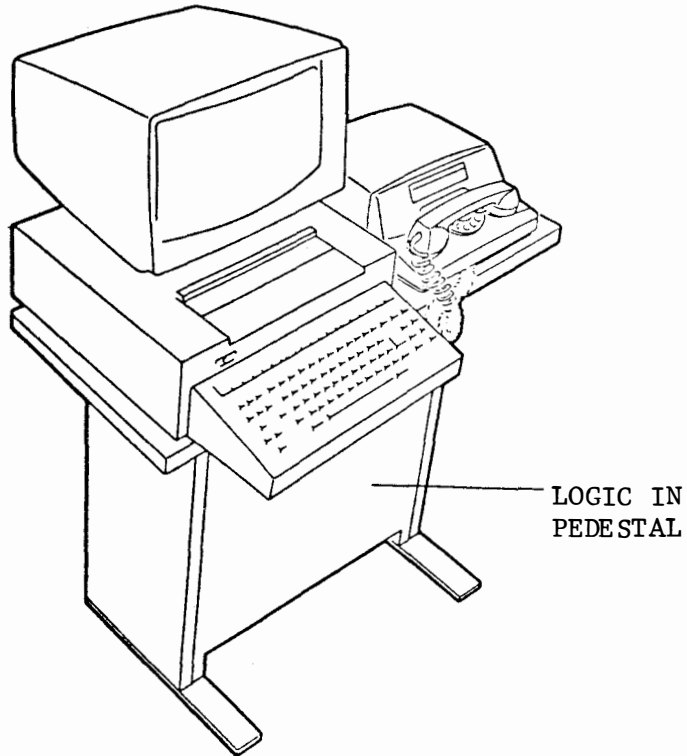

40 KSR (KDP) w/Data Set
(Pedestal Mounted)

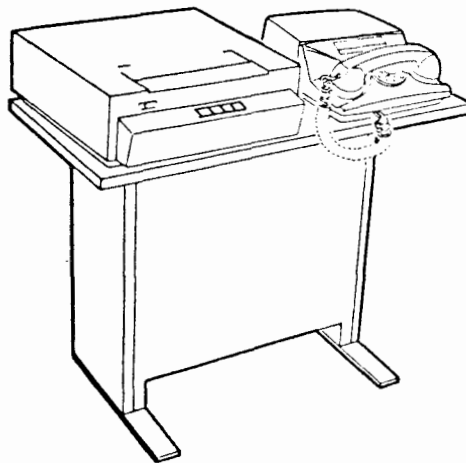

40 RO Printer w/Data Set
(Pedestal Mounted)

A. INTRODUCTION (Continued)

2. Identification (Continued)

c. Standard Features for Model 40 KSR Terminals

Operator Console
(Basic Complement--24-Line Display)

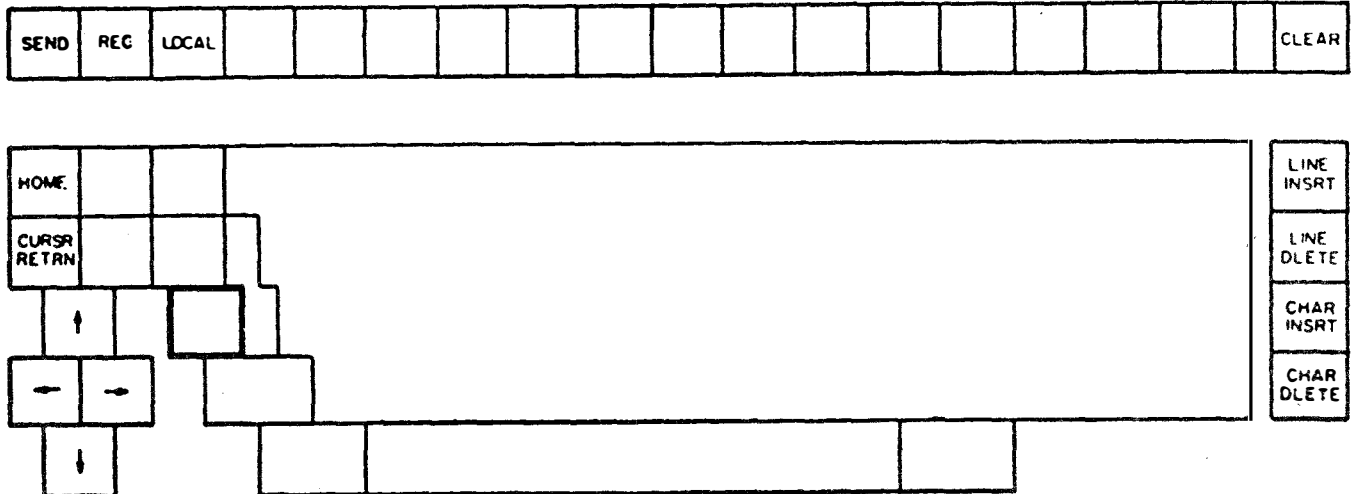

This keytop is provided when the terminal has a Model 40 page printer having an up-low character carrier. $\frac{A}{a}$ symbol on test. If CAPS LOCK is not provided when the terminal is equipped with a printer, the printer is equipped with a monospace character carrier. $\frac{A}{a}$ symbol on test.

d. Add-On Features for Model 40 KSR Terminals

Operator Console
(Complete Complement)

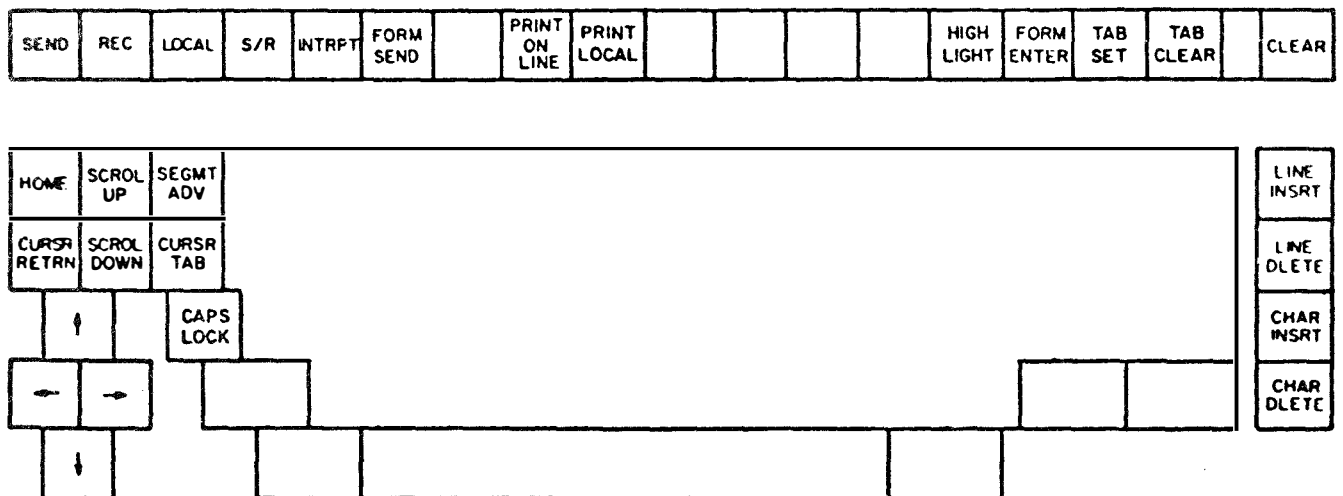

- A. INTRODUCTION (Continued)
- 2. Identification (Continued)
- d. Add-On Features for Model 40 Terminals (Continued)

Expanded Memory

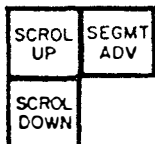

These edit controls are provided when terminal display memory is expanded to either 48 or 72 lines.

- 48 LINE expanded memory terminals have two 410004 or 005 circuit cards (in Segment 1 and Segment 2 positions) in the DISPLAY LOGIC MODULE.
- 72 LINE expanded memory terminals have three 410004 or 005 circuit cards (in Segment 1, 2, and 3 positions) in the DISPLAY LOGIC MODULE.

Full Edit

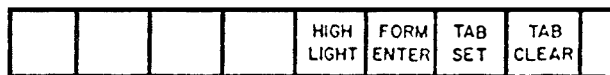
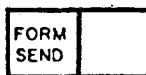

These edit controls are provided when a terminal has a complete edit complement.

Conversation Mode



- Provided on Operator Console for "line at a time" or "multiple line" operation.

Page Printer



- Provided in Operator Console arrangement when Model 40 page printer is provided with terminal.

External Mode Control

- Identified by presence of 410678 circuit card in slot X01 of controller module (PTI Sets only).

A. INTRODUCTION (Continued)

2. Identification (Continued)

e. Standard Features for Model 40 RO Terminals

f. Some RO terminals have a 1000 character storage unit. They can only be identified by the presence of 40C103AD book in the electronics package.

Operator Console

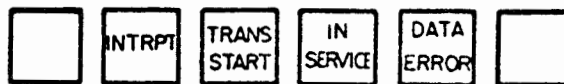

A. INTRODUCTION (Continued)

3. Field Options

- a. The options in paragraph c. are numbered and provide brief descriptions to facilitate choices available. A list of suggested data sets and options are provided in paragraph d. Complete descriptions of the Teletype set options are contained in paragraph e.
- b. Options marked with asterisk (*) are programmed at the factory.
- c. The options listed below may have been changed by the service center according to the customer order and should be entered on the Feature and Option record. Instructions for activating these options are contained in the Installation section paragraph B. 2.

1. Interface to Printer

- a. EIA
 - b. SSI*
- } Choose 1

2. S/R Send

- a. DC2 Sent Auto *
 - b. DC2 Sent w/Message
- } Choose 1

3. EIA Send/Receive Data Baud Rate

- a. 1050
 - b. 1200*
 - c. 2400
- } Choose 1 (on RO set, activated by service center only)
Reserved for future use.

4. EIA Reverse Channel

- a. Sent and Received*
 - b. Not Sent or Received
- } Choose 1

5. Response to Received Characters

- a. Reject Null*
 - b. Accept Null
 - c. Reject CR*
 - d. Accept CR
 - e. Reject Delete*
 - f. Accept Delete
- } Choose 1

6. Functions on Receive

- a. All ESC Seq. Displayed As Received
(Function Not Performed)
 - b. All ESC Seq. Are Performed As Received
But Not Displayed*
- } Choose 1

7. Errored Character On Receive

- a. Not Displayed On Vertical Parity Error
 - b. Displayed On Vertical Parity Error*
- } Choose 1

A. INTRODUCTION (Continued)

3. Field Options (Continued)

8. Page Ending Character Functions on Send

- a. End On FF
 - b. Do Not End on FF*
 - c. End On ETX*
 - d. Do Not End on ETX
 - e. End On EOT*
 - f. Do Not End On EOT
 - g. End On GS*
 - h. Do Not End On GS
- (Not optional on Switched Network)
- Choose 1
- Not Optional On Switched Network
- Choose 1

9. Highlight

- a. Delimiters Not Sent (Except In Form Send Mode)
 - b. Delimiters Sent (Modifies 13.)*
- Choose 1

10. Line Ending Sequence

- a. CR LF
 - b. CR CR LF*
 - c. LF
- Choose 1

11. Mode After Send

- a. Local*
 - b. Receive
 - c. EXT. Mode
- Choose 1 (on S.N. Sets applies to GS & ETX only)
- Must Select on Sets With EXT. Mode.

12. Form Enter

- a. Disabled in Local
 - b. Enabled in Local*
- Choose 1

13. Send Variations (All w/o Delimiters Except As Modified By 9b.)
In Form Send, Protect and Unprotect Sent As Displayed w/
Delimiters.

- a. Send All As Displayed
 - b. Send All As Displayed With Unprotected HT To Space*
 - c. Send Protect As Space And Unprotected As Displayed
 - d. Send Protect As Space And Unprotected As Displayed, HT To Space
 - e. Send Protect As Delete, Unprotected As Displayed
 - f. Send Unprotected Only As Displayed
 - g. Send Unprotected Only And HT At End Of Field
 - h. Send Unprotected Only w/Unprotected HT To Space
- Choose 1

14. Receive Selectable

- a. On*
- b. Off

15. Local and Send Mode Override

- a. Goes to Rec
 - b. Stays*
- See Pages 43 and 44

16. Mode After TDA

- a. Rec*
 - b. Loc
 - c. Home
 - d. Stays*
- Choose 1 Choose 1

A. INTRODUCTION (Continued)

3. Field Options (Continued)

17. Printer Margin And Form Length
- a. 1st Character On 1st Position* } Choose 1 (Sprocket feed only)
 - b. 1st Character On 2nd thru 12 (State #) } Choose 1
 - c. Last Character On 80th Position* } Choose 1
 - d. Last Character On 73rd thru 79th Position (State #) } Choose 1
 - e. Form Length 11" * } Choose 1 (Sprocket feed only)
 - f. Form Length 2-1/2" to 22" (State #) } Choose 1 (Sprocket feed only)
18. Printer Paper Feed Out
- a. No Paper Feed Out } Choose 1
 - b. Paper Feed Out On DCD Loss - 16 lines } Choose 1
 - c. Paper Feed Out On DCD Loss And ETX* } Choose 1
19. Printer Errored Character Symbol
- a. Printed on Even Parity Error* } Choose 1
 - b. Printed on Odd Parity Error } Must match type carrier ordered
 - c. Not Printed on Parity Error* } Must match type carrier ordered
 - d. Printers with 96 Character Set } Must match type carrier ordered
 - e. Printers with 64 Character Set } Must match type carrier ordered
 - f. Printers with Extended ASCII } Must match type carrier ordered
20. Line Feed On Printer
- a. Single } * Choose 1
 - b. Double } Choose 1
21. Foldover On Up-Low Printer
- a. Lower Case And Upper Case Print* } Choose 1 per type carrier ordered
 - b. Lower Case Prints As Upper Case } Choose 1 per type carrier ordered
22. Foldover On Mono Case Printer
- a. Lower Case Does Not Print } Choose 1 per type carrier ordered
 - b. Lower Case Prints As Upper Case* } Choose 1 per type carrier ordered
23. Extended ASCII On Printer (Extended ASCII)
- a. Prints Extended ASCII Characters } Choose 1 (S. C. only)
 - b. Does Not Print Extended ASCII (See 19a., b., or c.) } Choose 1 (S. C. only)
24. Controller Parity Detection (RO)
- a. Even Vertical Parity * } Choose 1 (S. C. only)
 - b. Odd Vertical Parity } Choose 1 (S. C. only)
25. Parity Error Response (RO)
- a. Odd Parity Null Sent To Printer } Choose 1 } (S. C. only)
 - b. Received Character Sent to Printer* } Choose 1 } (S. C. only)
 - c. Data Error lamp turns on } Choose 1 } (S. C. only)
 - d. Data Error lamp does not turn on* } Choose 1 } (S. C. only)

A. INTRODUCTION (Continued)

3. Field Options (Continued)

- 26. Trans. Start (RO)
 - a. Coded
 - b. Not Coded* } Choose 1
 - c. Sent
 - d. Not Sent* } Choose 1

- 27. Message Start
 - a. Home On Transmit
 - b. Send from Cursor*

- 28. Disconnect on Loss of Carrier
 - a. Disconnect After 45 Seconds *
 - b. Does not disconnect } Choose 1

A. INTRODUCTION (Continued)

3. Field Options (Continued)

e. Full Description of Options on KSR and RO M-40 Sets

- The M-40 Controller can act upon the incoming and outgoing data to accommodate various user required options. If a printer, is used additional options are also available. These options are selectable through the programming of the appropriate switches located in circuit cards in the controller logic module or on the printer.

1. Interface to Printer (410670 card) position X01

- a. EIA Printer option used when terminal is associated with a remote (maximum 50 ft) RO printer set with EIA interface. RO printer set has a character buffer.
- b.* SSI Printer option used with "adjacent printer unit" having an SSI interface.

2. Send/Receive S/R mode (410670 card) position X01

- a.* Auto Send on DC2.
Controller sends DC2 to processor when entered and receives a response. Multiline message without DC2 can then be sent back to processor. Message must end with DC4.
- b. DC2 sent with message.
Multiline message beginning with DC2 and ending with DC4 is sent to processor.

3. EIA Send/Receive Data Baud Rate (410671 card) position X02

- a. 1050 wpm speed.
Set has internal clock synchronized to send and receive at 1050 wpm. In the RO Set this also includes the internal test generator clock.
- b.* 1200 wpm speed.
Set has internal clock synchronized to send and receive at 1200 wpm. In the RO Set this also includes the internal test generator clock.
- c. 2400 wpm speed.
Reserved for future use.

4. EIA Reverse Channel (410671 card) position X02.

- a.* Reverse channel operative.
Data Set transmits Reverse Channel on line in response to reverse channel on at EIA interface in receive mode. Data set detects received reverse channel on line and presents reverse channel received at EIA interface.

A. INTRODUCTION (Continued)

3. Field Options (Continued)

e. Full Descriptions of Options on KSR and RO M-40 Sets (Continued)

4. (Continued)

b. Reverse Channel inoperative.

Data set does not transmit or detect Reverse Channel
(Option must be used on Bell System 202R data sets and
on 202C and D data sets w/o Reverse Channel).

5. Character Rejection (incoming data) (410674 card) position X05

a.* Reject Null.

In Receive mode, null characters are not displayed.

b. Accept Null.

In Receive mode, null characters are displayed.

c.* Reject Carriage Return (CR)

In Receive mode, CR characters are not displayed.

d. Accept CR.

In Receive mode, CR characters are displayed.

e.* Reject Delete.

In Receive mode, delete characters are not displayed.

f. Accept Delete.

In Receive mode, delete characters are displayed.

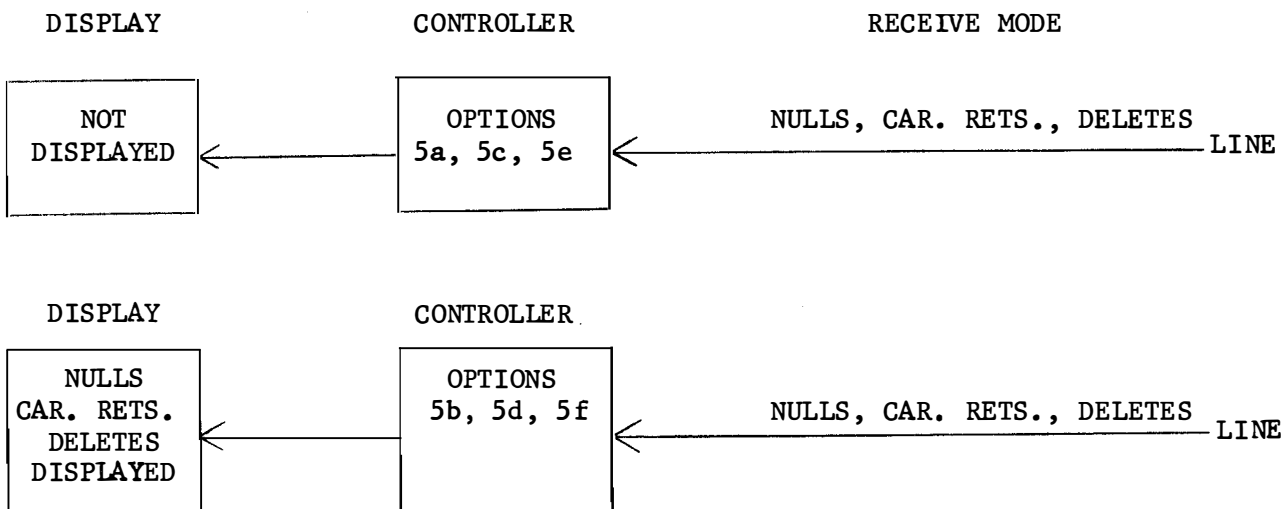

A. INTRODUCTION (Continued)

3. Field Options (Continued)

e. Full Descriptions of Options on KSR and RO M-40 Sets (Continued)

6. Functions on Receive (410674 card) position X05

- a. Disable on-line edit in Receive mode.
Permits Escape Sequences (Escape and second character) to be displayed and prevents functions from operating.
- b.* Enable on-line edit in Receive mode.
Prevents Escape Sequences (Escape and second character) from being displayed and permits the display logic to perform the appropriate function.

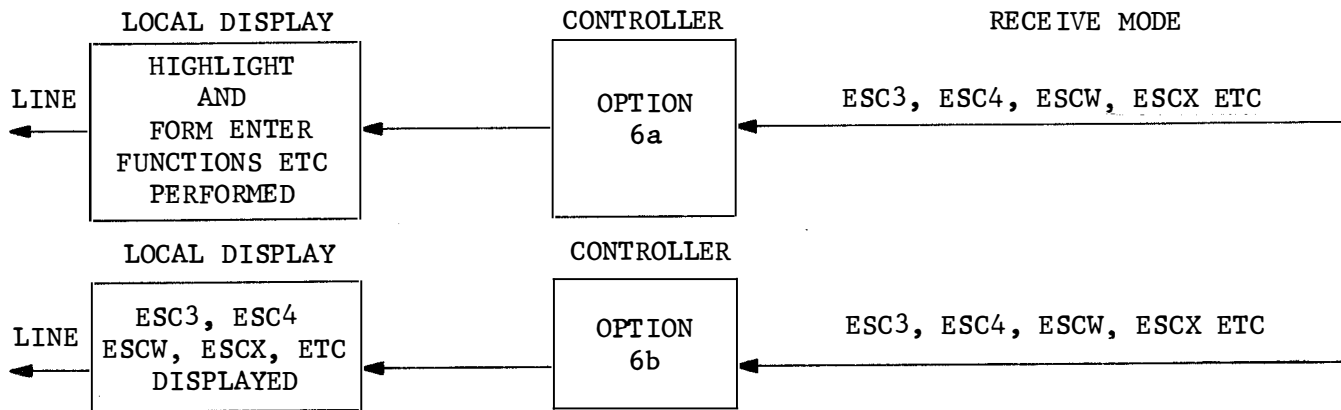

7. Errored character on receive (410674 card) position X05.

- a. Substitute character does not replace errored character.
When received vertical parity error (odd) is detected.
- b.* In Receive mode when vertical parity error (odd) is detected, errored character is replaced by ASCII substitute character (S_b) and displayed.

8. Send Message (page) Ending Character (410674 card) position Z05.

- a. End message on Form Feed (FF).
Data transfer ceases and send mode terminates on FF character (not used in S.N. applications).
Mode after send depends on option 11a or 11b.
- b.* FF inoperative as message ending code.
- c.* End message on End of Text (ETX).
Data transfer ceases and mode terminates on ETX character.
Mode after send depends on option 11a or 11b.
- d. ETX inoperative as message ending code.
- e.* End message on End of Transmission (EOT).
Data transfer ceases and mode terminates on EOT character. Option must be in on S.N. Applications.
Mode after send changes to RECEIVE on S.N. applications.
On PTI sets mode after send depends on 11a or 11b.

A. INTRODUCTION (Continued)

3. Field Options (Continued)

e. Full Description of Options on KSR and RO M-40 Sets (Continued)

8. (Continued)

- f. EOT inoperative as message ending code (not selected on S.N. applications).
- g.* End message on Group Separator (GS).
Data transfer ceases and mode terminates on (GS) character. Mode after send depends on option 11a or 11b.
- h. GS inoperative as message ending character.

9. Sending Highlight Delimiters (410674 card) position X05.

- a. Disable Highlight in Send mode.
Highlight delimiters (Esc 3 and Esc 4) are not sent, except in FORM SEND mode.
- b.* Enable Highlight in Send mode.
Highlight delimiters are sent, without being in FORM SEND mode, which modifies options 13a through 13g.

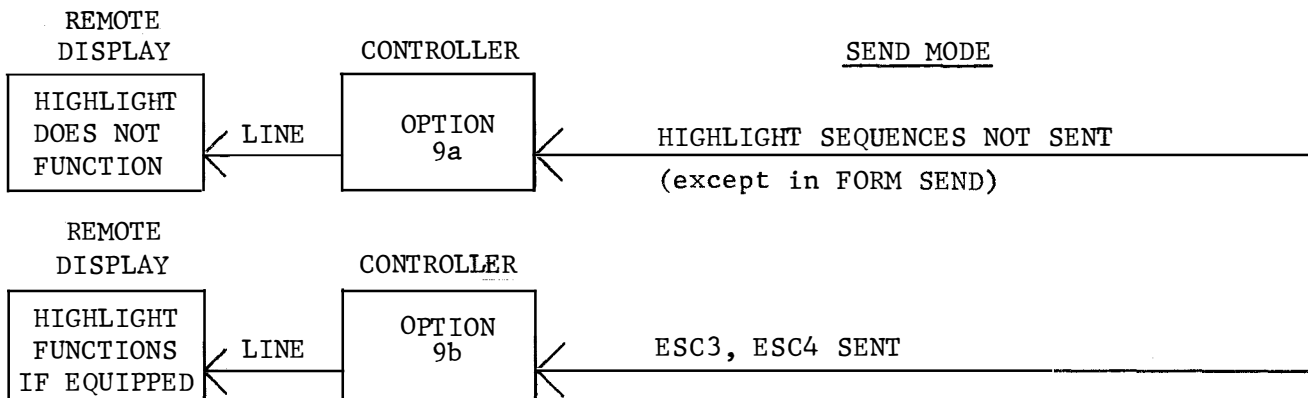

A. INTRODUCTION (Continued)

3. Field Options (Continued)

e. Full Descriptions of Options on KSR and RO M-40 Sets (Continued)

10. Line Ending Sequences Sent (410675 card) position X04.

- a. Precede Line Feed with Carriage Return - Send mode.
Line Feed is displayed, Carriage Return is generated.
- b.* Precede Line Feed with two Carriage Returns - Send mode.
Line Feed is displayed, 2 Carriage Returns are generated.
- c. Line Feed is displayed.
Only Line Feed is sent.

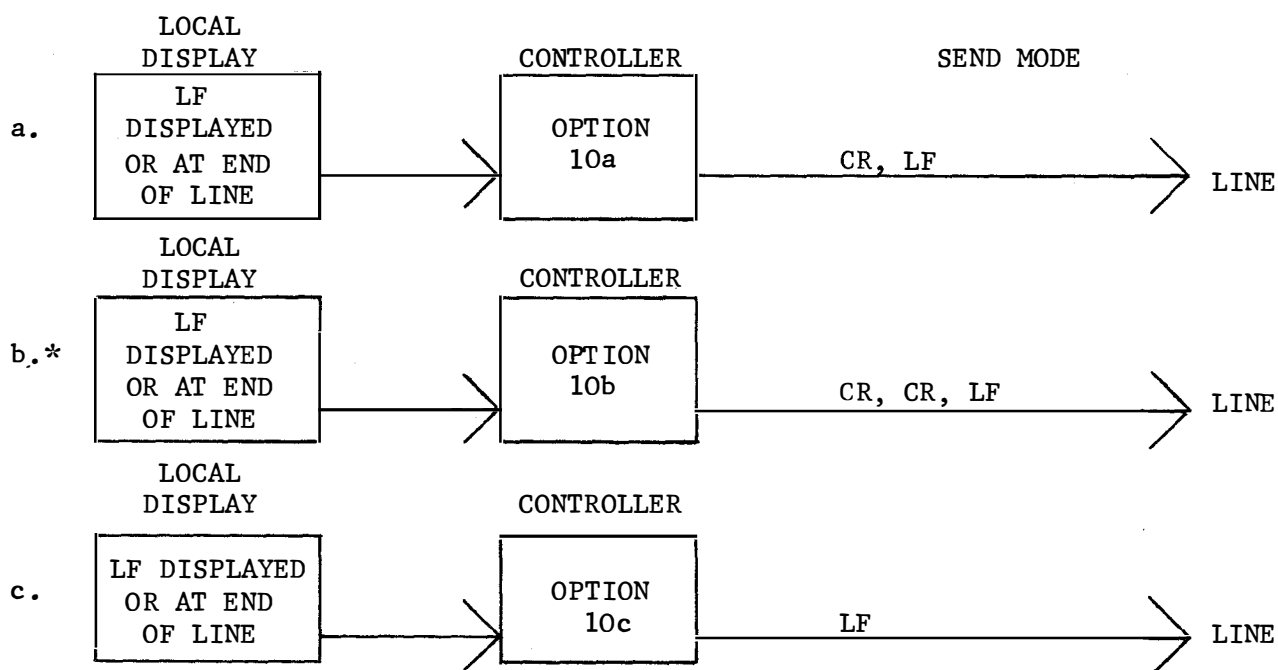

A. INTRODUCTION (Continued)

3. Field Options (Continued)

e. Full Descriptions of Options on KSR and RO M-40 Sets (Continued)

11. Mode after Send (410675 card) position X04.

a.* Go Local after Send.

Set returns to Local mode after enabled message ending character in Send mode. On S.N. applies only to ETX and GS (8c and 8g).

b. Go Receive after Send.

Set returns to Receive mode enabled after message ending character in Send mode. On S.N. applies only to ETX and GS (8c and 8g).

c. Disables a. and b. (option 16 a. or b. takes precedence).

12. Form Enter in Local (410675 card) position X04.

a. Disable Form Enter in Local mode (cannot enter or change protected data).

b.* Enable Form Enter in Local mode.

13. Send Variations (410676 card) position X03.

Options 13a through 13h send no delimiters except as modified by option 9. b. (highlight delimiters only). When FORM SEND mode is used, disregard all options 13a through 13h. All displayed data protected and unprotected, plus all Escape sequences are sent in FORM SEND mode. When FORM SEND mode is not used, the following variations are available (Note: Converted characters are not).

a. Send All without delimiters.

Send protected and unprotected displayed data, but no delimiters (escape sequences). Exception is option 9b - highlight Escape 3 and Escape 4 are sent.

b.* Send All without delimiters and convert Horizontal Tab (►) to Space. No delimiters sent (see 13a exception). 13b same as 13a with conversion of transmitted ► characters to Space.

c. Send Unprotected data as displayed, Protected data as Space. No delimiters sent (see 13a exception).

d. Send Unprotected data as displayed, Protected data as Space. No delimiters sent (see 13a exception).

13d same as 13c with conversion of transmitted ► characters to Space.

e. Send Unprotected data as displayed, Protected data as Delete. No delimiters sent (see 13a exception).

A. INTRODUCTION (Continued)

3. Field Options (Continued)

e. Full Descriptions of Options on KSR and RO M-40 Sets (Continued)

13. (Continued)

f. Send Unprotected data only as displayed. No delimiters sent (see 13a exception).

g. Horizontal Tab and Skip.

This Send option provides a method of rapidly moving through displayed text containing both Protected and Unprotected data. All Protected data is removed from the transmitted data. When a Protected field is reached, the controller generates an HT character, then skips to the first Unprotected character. When an HT character is in the display, the HT is sent, then the controller skips to either an Unprotected tab mark if present, or to the first character in an Unprotected field.

No delimiters sent (see 13a exception).

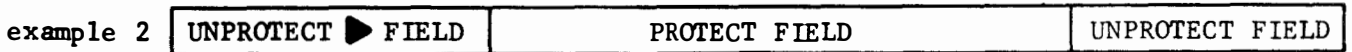
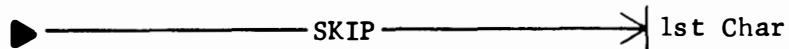

GENERATED
BUT NOT DISPLAYED

and

h. Send Unprotected only with Unprotected HT to Space. No Protected data sent and any Unprotected on the display transmitted as a Space. No delimiters sent (see 13a exception).

A. INTRODUCTION (Continued)

3. Field Options (Continued)

e. Full Descriptions of Options on KSR and RO Sets (Continued)

Additional Options in PTI-Type Sets

14. Receive Selectable (410677 card) position X02.

- a.* Receiver Selectable to external interface.
Provides an indication to interface when terminal is in the REC mode.
- b. Receiver not Selectable to external interface.
Indicates to interface that terminal is not in REC mode regardless of actual mode.

15. Incoming Message Override (410678 card) position X01.
When this card is used, option 11c must be activated.

- a. A priority situation causing an immediate switch to the Receive mode, regardless of set status. The cursor home function is also performed.
- b.* Override function is not performed. Set stays in Send or Local Modes.

16. Mode after TDA (410678 card) position X01. TDA is the received acknowledgement that a transmitted data message has been received correctly by the remote location.

- a.* Go to Receive mode after TDA.
- b. Go to Local mode after TDA.
- c. Cursor go to Home position after TDA.
- d.* Cursor stays at message end after TDA.

17. Printer Margin and Form Length.

- a.* 1st character prints on left most position.
- b. 1st character prints on 2nd thru 12th position from left. Must state position desired.
- c.* 80th column
- d. Last character prints on 73 thru 79th position. Must state position desired.

e or f Form Length - Available on sprocket feed printers only
(Future)

FIRST CHIP ON LEFT OF CONT. CARD
STRAPPED TO BRING IN LEFT MARGIN.

A. INTRODUCTION (Continued)

3. Field Options (Continued)

e. Full Descriptions of Options on KSR and RO Sets (Continued)

18. Printer Paper Feed Out
16 lines of paper feed out can be switch programmed for (b) feed out on detection of RM (on EIA sets DSR loss caused by carrier loss, on disconnect) or ending of PRINT LOCAL or DATA modes. *(c) feed out on detection of RM loss and detection of ETX, or (a) no paper feed out.

19. Printer Errored Character Symbol
The errored character symbol is the carrier symbol ($\begin{matrix} A \\ A \end{matrix}$)
monocase, $\begin{matrix} A \\ A \end{matrix}$ up-low) which is printed under the following condition. If the noncontrol character received by the printer is not part of the character set, except when lower case characters are folded over to print upper case. It may be printed or not printed upon detection of a parity error. Options 19a* (printed on even parity error), 19b (printed on odd parity error), and 19c (not printed) are programmed by 2 switches on the 410640 circuit card assm in the printer (refer to Sec B2). To avoid unnecessary delays, two switches on the 410640 circuit card assm MUST be programmed to indicate to the printer electronics which character set is being used. Option 19d, e, & f. (Refer to Sec B2).

20. Line Feed
Single or double line feed may be selected by the operator with a switch on the printer (inside cover). Refer to Sec B.2.

A. INTRODUCTION (Continued)

3. Field Options (Continued)

e. Full Descriptions of Options on KSR and RO Sets (Continued)

21. & 22. Foldover

The foldover option *22b. enables a monospace printer to print "lower case ASCII" characters as "upper case ASCII" characters. (See glossary.) A monospace printer without foldover 22. a. will

print the carrier symbol $\begin{matrix} A \\ A \end{matrix}$ for lower case ASCII characters

except Delete. Similarly, the up-low printer will print only the upper case ASCII characters if the foldover option 21. a. is enabled. This option is programmed by a switch on the 410640 Circuit Card Assm in the printer (Refer to Sec B2).

Note: On monospace printers with 40PL191 Printer Electronics Book Assm in the pedestal the foldover option is factory wired (strap option) as foldover enabled.

23. Extended ASCII (Future Use)

A switch option allows the 8th bit of the ASCII code to be used to provide up to a maximum of 191 characters to be printed on the 80 column printer, and up to 222 characters on the 132 column printer.

24. Controller Parity Detection (RO Set only) see option 25.

*a. Used when even parity ASCII characters are being received. Provides error indication on ODD parity.

b. Used when ODD parity ASCII characters are being received. Provides error indication on EVEN parity.

25. Parity Error Response (RO set only) see option 19 & 24.

a. Upon detection of parity error, converts the character to an ODD parity NULL and sends this character to printer; if 19b. is selected printer will print errored character.

*b. Will not change received character that had parity error.

c. Data ERROR lamp lights and stays lit upon detection of parity error until cleared by depressing key.

*d. Data Error lamp does not light upon detection of parity error.



A. INTRODUCTION (Continued)

3. Field Options (Continued)

e. Full Descriptions of Options on KSR and RO Sets (Continued)

26. TRANS. Start (RO Set only)

- a. 14 bit discrete calling identifier code is programmed
- *b. Code not programmed (all blank)
- c. Programmed code sent.
- *d. Programmed code not sent.

27. Message Start

- a. Home On Transmit - This option automatically homes the cursor when the message is transmitted.
- *b. Transmit From Cursor - With this option only the message on the cursor line and below will be transmitted. Option 27 is programmed by a switch on 410675 Circuit Card Assm in the controller.

28. Disconnect or Loss of Carrier

- *a. In the Receive mode, a timer starts on loss of carrier (DCD). After 45 seconds, a disconnect sequence is initiated by turning off Data Terminal Ready (DTR) to the EIA interface.
- b. No disconnect sequence initiated upon loss of carrier (DCD).

A. INTRODUCTION (Continued)

4. Interfacing

- The Model 40 terminals and units have three basic types of electrical interface:
EIA - Electronic Industries Association — Standard RS-232-C
PTI - Parallel Terminal Interface
SSI - Standard Serial Interface
- In this manual the EIA terminals are considered to interface with Bell System 202 data sets equipped with dial and ringer forming a terminal used in switched network applications. A 2-wire tip and ring telephone connection then forms the terminal interface.
- The PTI (including some external mode controls) connector and a connector with additional external mode (error) controls are the terminal interface. All operation across the PTI interface, as covered in this manual, requires use of the TSG803 Test Set.
- In this manual, SSI is an internal interface used between various components that make up a Model 40 Terminal.

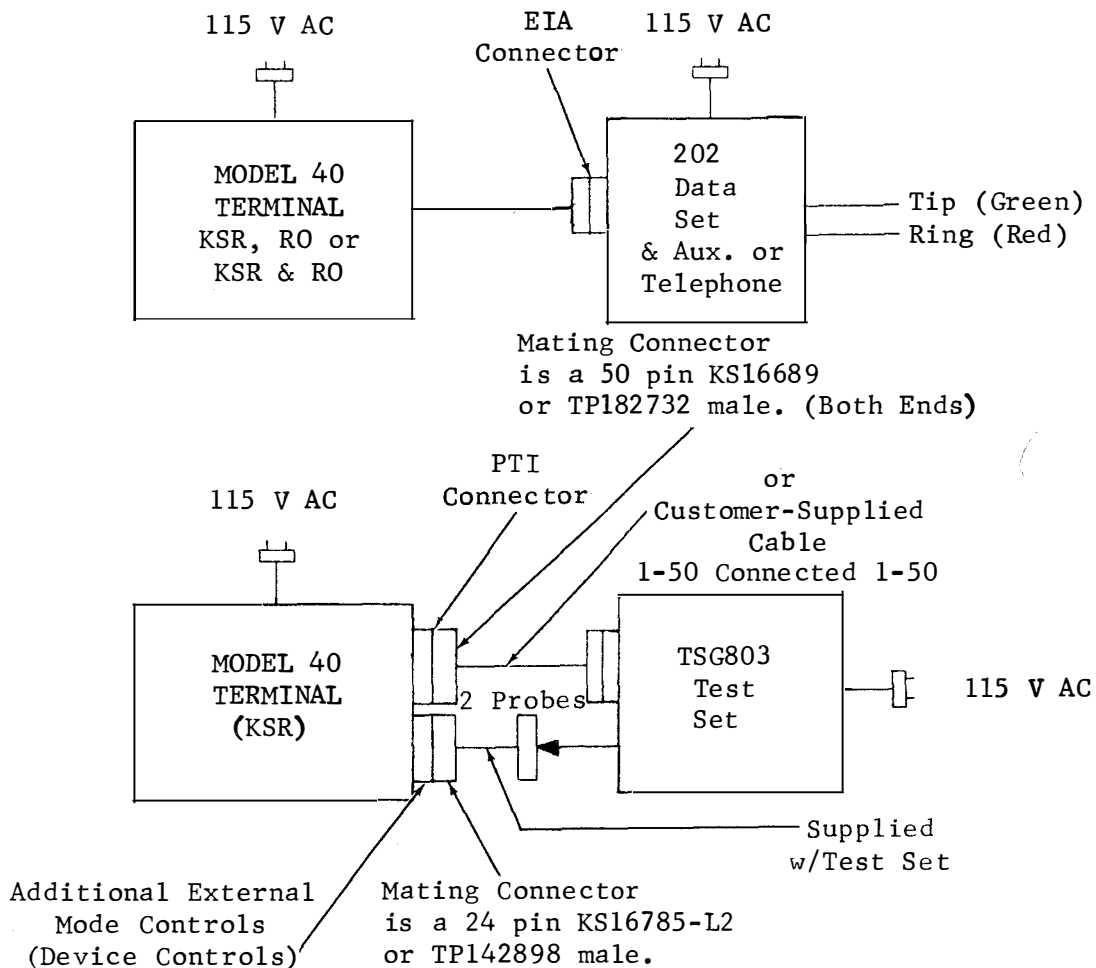

A. INTRODUCTION (Continued)

5. Technical Data

a. Power source requirements

115 v ac $\pm 10\%$ 60 Hz ± 0.5 Hz from an unswitched, standard 3-wire grounding type receptacle.

Depending on the terminal configuration, up to 3 receptacles are required. The logic module, printer, and paper winder individually require an outlet. Terminals with pedestal (equipped with a power convenience strip- 7 receptacles) require only one outlet except when the printer is located apart from the pedestal, an additional outlet is required.

b. Power consumption and heat dissipation

			Approx. <u>Current Draw</u>
KDP	360 Watts	1230 BTU/hr.	4.5 AMPS
Keyboard Display	260 Watts	885 BTU/hr.	2.7 AMPS
RO Terminal	260 Watts	885 BTU/hr.	3.2 AMPS

c. Environmental restrictions (operating)

Ambient Temperature	+40°F to +110°F
Relative Humidity	2% to 95% (noncondensing)

d. Weight (approximate)

	<u>Unpacked</u>	<u>Packed</u>
Display Monitor w/Housing	42 lbs	
Terminal Logic	50 lbs	
Printer & Printer Logic	40 lbs	
Housing for Terminal Logic or Printer	15 lbs	
Operator Console w/Cover	5 lbs	
Pedestal	56 lbs	
Test Set (TSG803)	16 lbs	
Card Caddy		

e. Dimension (space requirements)

f. Paper standard single ply 8-1/2 wide 5" dia roll.

g. Ribbon TP400444 or IBM 1443 twin spool ribbon 36 yds BLK EE #40 SMIL.

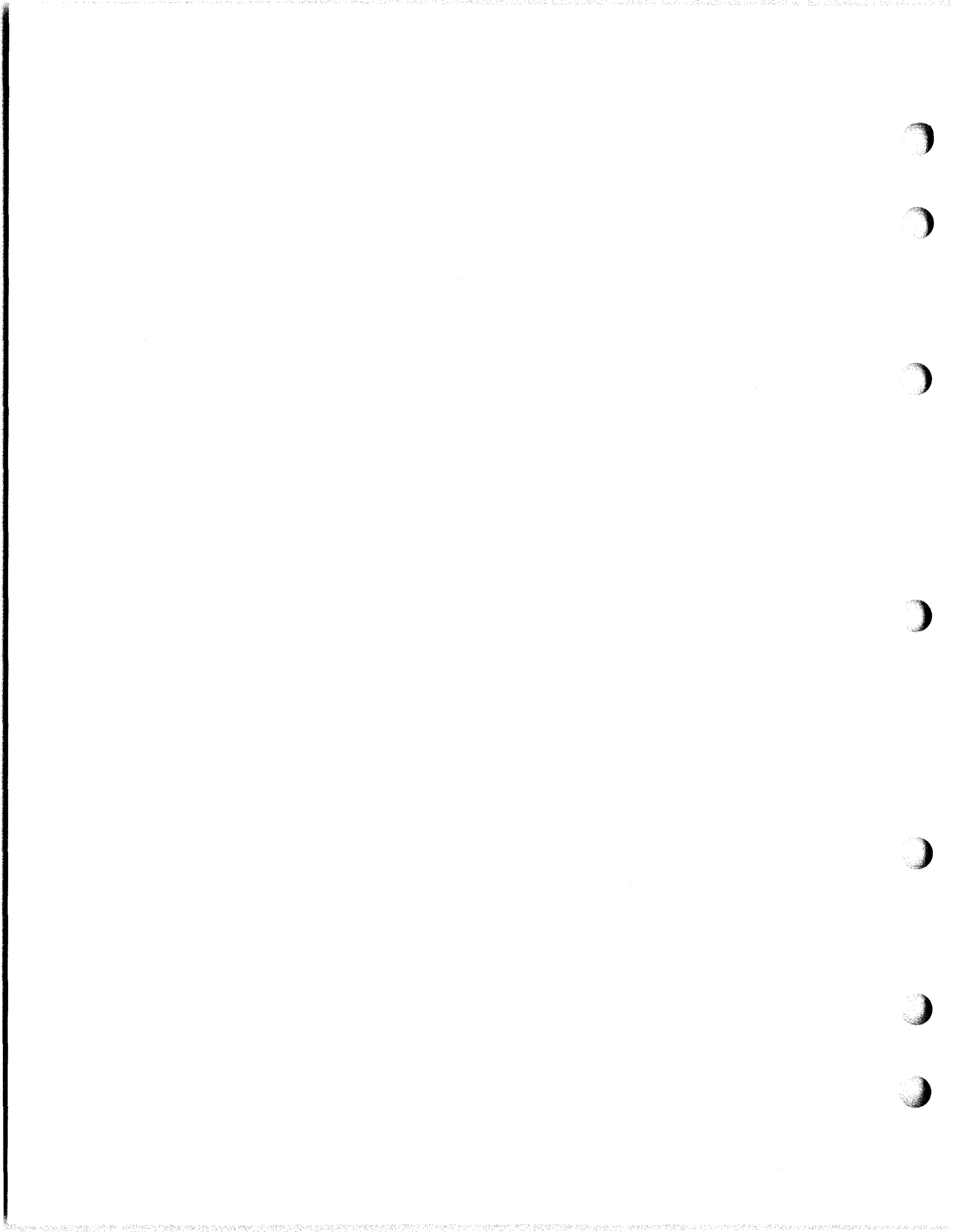

A. INTRODUCTION (Continued)

6. Tools and Supplies

The following tools and supplies may be required for installation or servicing of Model 40 apparatus, most of these items should normally be present in standard maintenance tool kits available from Teletype Corporation Service Parts Division.

Tools

Wrench, Open End	3/16 & 1/4	TP129534
	5/16 & 3/8	TP152835
Nut Driver	Handle	TP135676
		TP135677
		TP135678
Screwdriver	1/8" x 2" Blade	TP95368
	1/4" x 6" Blade	TP100982
Allen Wrench	.062	TP124682
Tweezers		TP151392
Spring hook (pull)		TP142554
Scales, Spring		TP110443
Ruler, 6"		TP95960
Cleaning Brush (Type Face)		TP151394

Supplies

All purpose grease Lubriplate*	
2 oz tube	TP108805
Oil	KS7470

*Trademark of Fiske Brothers Refining Company

A. INTRODUCTION (Continued)

7. Test Facilities (TSC803 and Service Centers)

- Teletype Product Service Centers have personnel available to install and perform on-line checkout procedures and to isolate terminal troubles.
- A portable test set, Parallel Signaling Terminal Simulator (TSG803) is available from Teletype Corporation to isolate PTI-type Model 40 display terminals from external applications for testing purposes. Its application is covered in Section C under Complete Checkout.

A. INTRODUCTION (Continued)

8. Definitions of Terms

Alarm - A bell tone of short duration which alerts the operator to a special situation on FULL EDIT sets only.

ASCII Control Characters - All ASCII characters except DEL (lower case ASCII) generated by simultaneous use of the control designated key and the CONTROL key in addition to TAB, NEW LINE, RETURN and  keys i.e. character codes with 6 & 7 bits spacing.

Basic Terminal - That portion common to all Model 40 KSRs or ROs that does not include add-on features such as conversational mode, 2 or 3 segment display, full editing features, or exceptions to factory furnished field options. It includes variations such as printer, pedestal, and monospace or up-low.

Character Field - A group of consecutive Unprotected Characters within a line bounded on the left by either the beginning of the line, a Tab Mark, or a Protected Character, and bounded on the right by either the end of the line, a Tab Mark, or a Protected Character.

Control Character Display - Control Characters as displayed in abbreviated, subscripted or graphic form. Graphic displays are as follows: HT ►, NEW LINE ≡, RETURN ← and DEL //.

Conversational Mode - a feature that may be present on terminals used on switched network applications that provide line at a time or multiline sending.

Cursor - A solid white rectangle displayed on the tube face indicating the position of the next character to be written or function to be performed.

When a character is already in memory at the cursor the image will be displayed within the cursor in a negative (black on white form).

The cursor is always on the tube face.

Data Mode - Data set mode in which modem is connected to telephone line and the telephone is not connected. DATA lamp lighted.

Delimiter - Character sequence that controls subsequent functions.

Display Logic - A storage and control device in all terminals with a Display Monitor that stores all the data on the page and performs the editing and other functions visible on the display.

Editing Clusters - 3 groups of keys on operator console. Left cluster does not affect data, right and full edit clusters affect data.

EIA - Electronics Industries Association (Voltage) Interface.

End of the Line - Either the 80th character position or the character position just before a protected New Line.

A. INTRODUCTION (Continued)

8. Definitions of Terms (Continued)

Errored Character - \boxed{A} on monospace, \boxed{a} on up-low printers and

S_b on the Display Monitor. Occurs if lower case ASCII character is received on monospace printer without the foldover option or when parity error is used.

Feature and Option Record - A tear out sheet provided in the Installation and Servicing Manual that is marked with a record of the type of terminal, its features, and field options; and placed in the cabinet behind the operators console.

Foldover - A printing option that converts all received lower case ASCII characters except Delete into upper case ASCII characters as follows:

All alpha
~ to ^
| to \
[to {
] to }
\ to @

Full Editing Features - A group of features, that are present on some terminals, that include; Highlight, Form Enter and Horizontal Tab & Alarm.

Highlighted Character - A displayed character that alternates between full and half intensity once per second.

Home - The first character position of the first line of the page in the upper left hand corner of the screen.

KSR - In this manual, is defined as a Model 40 send receive terminal having a keyboard and a display device. In addition it may contain a page printer, pedestal, or a number of added features.

Line Field - A group of consecutive lines all having the same maximum line length and containing no Protected Characters other than Protected New Line characters.

This Field is bounded at the top by either the top of the Page, a line with a different End of the Line, or a line containing one or more Protected Characters other than New Line. It is bounded at the bottom by either the bottom of the Page, a line of a different maximum length or a line containing one or more Protected Characters other than New Line.

Lower Case ASCII Character - Lower case alpha characters and tilde ~, vertical line |, left and right brace { }, grave accent ` , and delete // .

Monospace - A terminal not capable of printing ASCII lower case or ASCII CONTROL characters or of generating lower case alpha characters.

OPCON - Abbreviation for Operator Console (includes operational control key strip and may include editing clusters and keyboard).

A. INTRODUCTION (Continued)

8. Definitions of Terms (Continued)

Operational Control Keys: Keys on the operator console that indicate the status or control the operational mode of the set or terminal.

Page - The total data storage capability of the Display Logic. It consists of one, two or three segments each of 24 lines of 80 characters.

Parity Error - Incorrect number of data bits (Odd or Even) in an ASCII character.

Protected Character - A character or character position which cannot be changed or moved unless the Operators Console is in the Form Enter Mode. These characters are displayed at one-half the intensity of the unprotected characters.

PTI - Parallel Terminal (Current) Interface.

Raster - A display of horizontal lines across the screen vertically spaced 14 per cursor height and normally visible only when the BRIGHTNESS control is turned to full intensity.

RO - In this manual, is defined as a Model 40 receive only page printer or a terminal having a page printer. It may contain a pedestal and an operators console without a keyboard or display.

Screen - The area where data is displayed on the tube face. The maximum display on the screen is 24 lines of 80 characters per line.

Scrolling - The shifting up or down the page, when more than one segment is provided, of the selection of which 24 line portion of the page will be displayed on the screen.

Segment - A segment is a defined group of 24 lines of 80 characters (lines 1-24, 25-48, or 49-72). This is the maximum number of lines that can be displayed on the Display Monitor at one time.

Segment Marks - The following identifiers are permanently displayed to the left of the first line of each page segment:

<u>Segment Mark</u>	<u>Page Line No.</u>	<u>Segment No.</u>
—	1	I
==	25	II
≡	49	III

One of these marks will always be present on the screen regardless of what portion of the page is being displayed. This provides the operator with a reference aid. These marks do not occupy any of the 80 character positions on the line.

SSI - Standard Serial Interface. (used internally in Model 40 devices)

A. INTRODUCTION (Continued)

8. Definitions of Terms (Continued)

Switched Network Applications - Applications involving use of a telephone or a device equipped with a telephone dial and ringer used to originate and answer calls in either the TALK or DATA modes over Switched Network (S. N.), DDD etc telephone facilities.

Tab Mark - A small dot displayed in the lower left hand corner of a character position. It indicates where a Horizontal Tab has been set.

Tab Stop - Any of the following:

1. A Tab Mark located at an Unprotected Character position.
A Tab Mark located at a Protected Character position is not treated as a Tab Stop.
2. The first Unprotected Character position following a Protected Character.
3. The first position on a line if it is Unprotected.
4. The last character position on the last line of the page.

Unprotected Character - A character or character position which can be changed or moved using the normal editing functions of the Operator's Console. Unprotected characters are displayed at full intensity.

Up-Low - A terminal capable of generating all 128 ASCII characters including lower case alpha and ASCII and (if equipped with a printer), of printing all except delete, space and ASCII control characters.

Upper Case ASCII - All 128 ASCII characters with the exception of ASCII lower case and control characters.

A. INTRODUCTION (Continued)

9. Performance Reporting

- a. When sets are first installed the Model 40 registration card included with each set should be filled out and mailed to Teletype Corporation P.E.C.C.
Repair Engineering Organization
5555 W. Touhy Ave.
Skokie, Illinois 60076
Dept. 3211 (Teletype Operator 312-982-2000)

The set reference number can be obtained from the decal located under the logic cabinet cover (Right front corner) or, when the logic is mounted in the pedestal, inside the pedestal (Right Side front edge).

The operation of the set should be indicated along with an explanation of any defects. Refer to the reduced size reproduction of the card on the next page.

Please write or call the above organization to report performance problems subsequent to the initial registration card report. See b. for service assistance.



MODEL 40 REGISTRATION CARD
IMPORTANT _____ FILL IN AND MAIL

CUSTOMER _____

ADDRESS _____

NAME OF MAINTENANCE CONTACT _____

TELEPHONE NO. _____

DATE OF INSTALLATION _____

TYPE OF SET KD KDP RO

SET REFERENCE NO. _____

HOW WAS OPERATION ON RECEIPT:

SATISFACTORY

NOT SATISFACTORY (EXPLAIN) _____

← FILL
OUT

Postage Will be Paid By Addressee

BUSINESS REPLY MAIL
No Postage Stamp Necessary if Mailed in the United States

FIRST CLASS
Permit No. 480
Skokie, Illinois



← MAIL
TO

TELETYPE CORPORATION P.E.C.C.
REPAIR ENGINEERING ORGANIZATION
5555 W. TOUHY AVE.
SKOKIE, ILLINOIS 60076
DEPT. 3211



A. INTRODUCTION (Continued)

9. Performance Reporting and Service Assistance (Continued)

b. Service Assistance

In the event troubles are encountered with a Model 40 terminal for which no spare components are on hand or to replenish stocks of spare components, your service organization can obtain repaired replacements on an exchange basis from the Teletype Corporation Product Service Center in Westchester, Ill. 312-345-7920

Most defective components can be sent back in the "mailers" provided with each station. Larger components may require local packing before being returned. In all cases however the Product Service Center should first be contacted for pricing, scheduling out-of-service situations and the nature of the defect. As indicated in a. a report should also be made to the Repair Engineering organization.

Normal service assistance routines should still be followed in accordance with any locally established procedures.



B. INSTALLATION



B. INSTALLATION

1. Preparation for Installation of Set

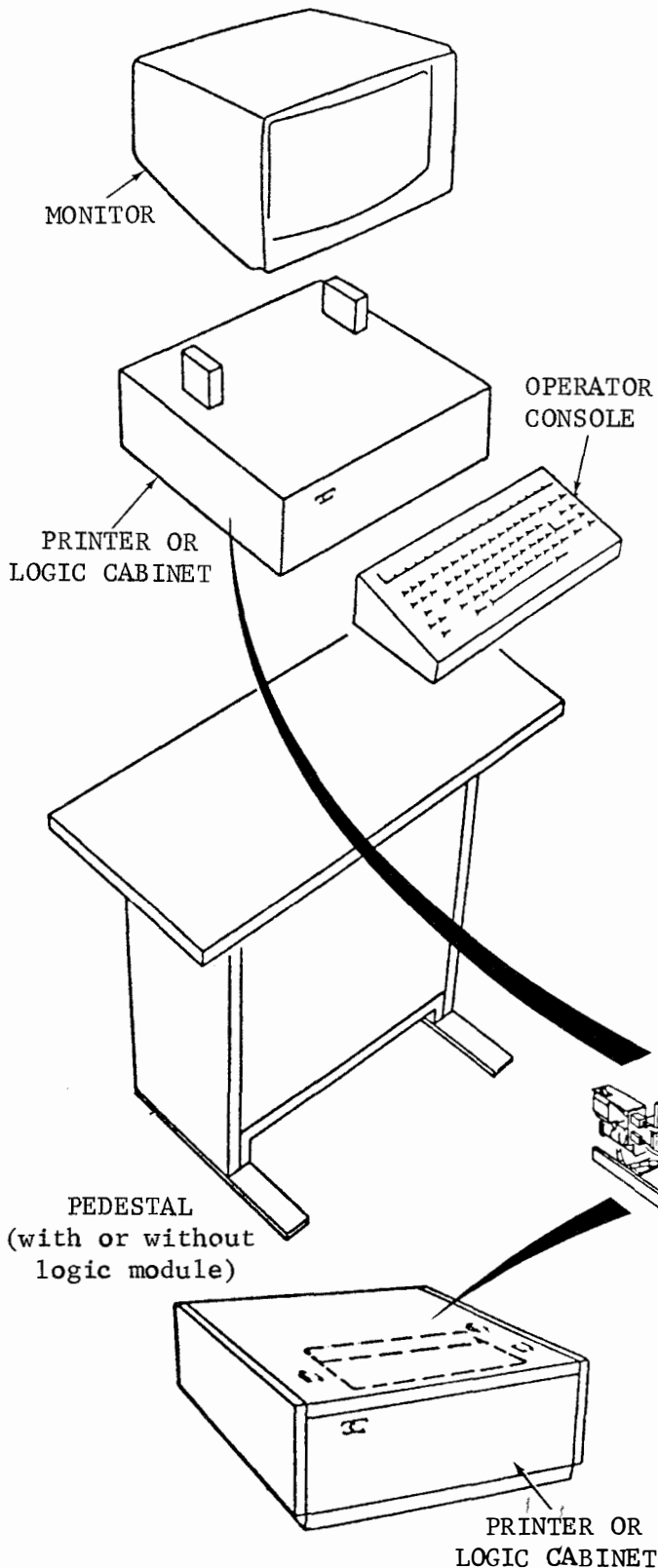

Unpacking

Unpack each carton per instructions on the corrugated cardboard container.

Observe all caution notes printed on the packing carton.

Place the unpacked equipment in the assembly area so that damage will not occur.

The pedestal should be unpacked first so that the printer and operator console cabinets can be placed on it.

Unpack from Factory

Components individually packaged as assemblies

- a. Monitor
- b. Printer
- c. Logic Cabinet
- d. Pedestal
- e. Printer Cabinet (without printer)

Note: If set is to be reshipped, save cartons and packing details.

Unpack from Service Center

Unpacking from the Service Center will vary based upon shipping conditions. Most of the unpacking will be the same as the factory shipment.



B. INSTALLATION (Continued)

1. Preparation for Installation of Set (Continued)

For Component Access

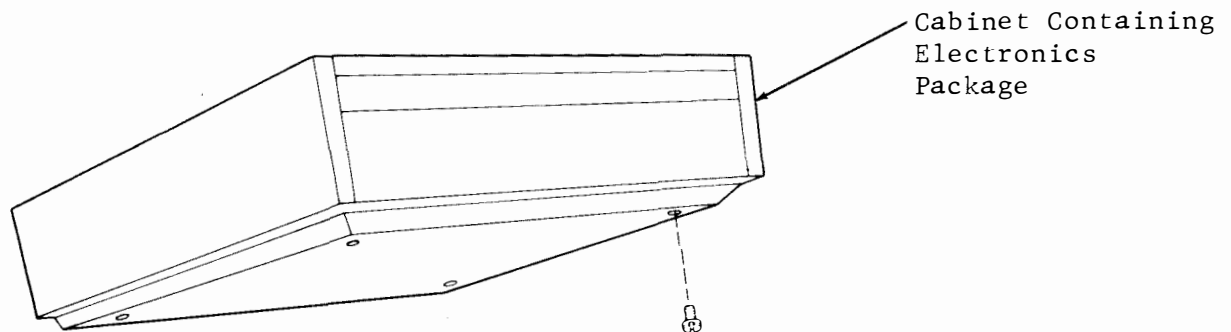

- ① Tilt up cabinet or place over edge of pedestal top.
- ② Remove Shipping Screws (4 places)
- ③ Retain for reshipment

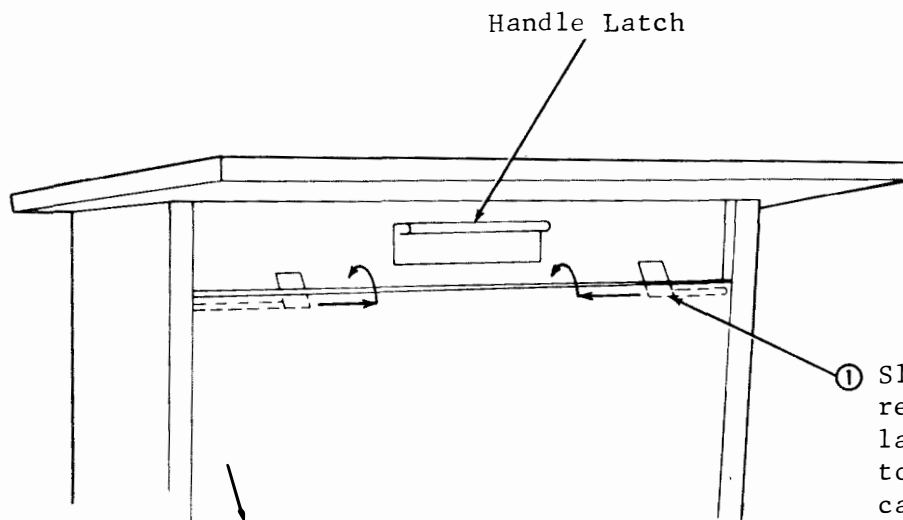

- ② CAUTION
Grasp handle firmly when opening door since weight of Electronics Package mounted on the inside will become overcentered.

- ① Slide tabs inward to release panel. Handle latch must be squeezed to open panel. ③ Tabs can be rotated to become nonfunctional or if desired may be utilized to discourage opening of door by nonservice personnel.

B. INSTALLATION (Continued)

2. Activating Options and Modifications

- If any field options are to be changed or checked for proper position (See Section A.3. for descriptions) turn off power and remove cards if necessary using procedures shown below. (See Section F for access to components)
- The feature and option record should be marked to show any options that differ from factory furnished (*).

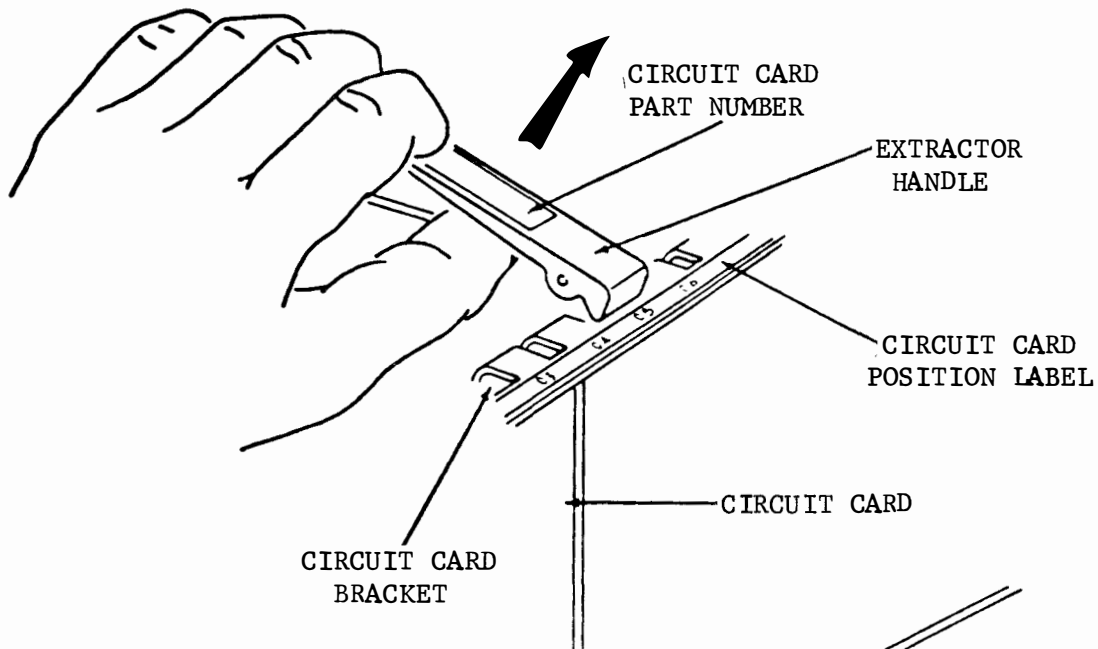

STEP 1. EXTRACTING CIRCUIT CARD

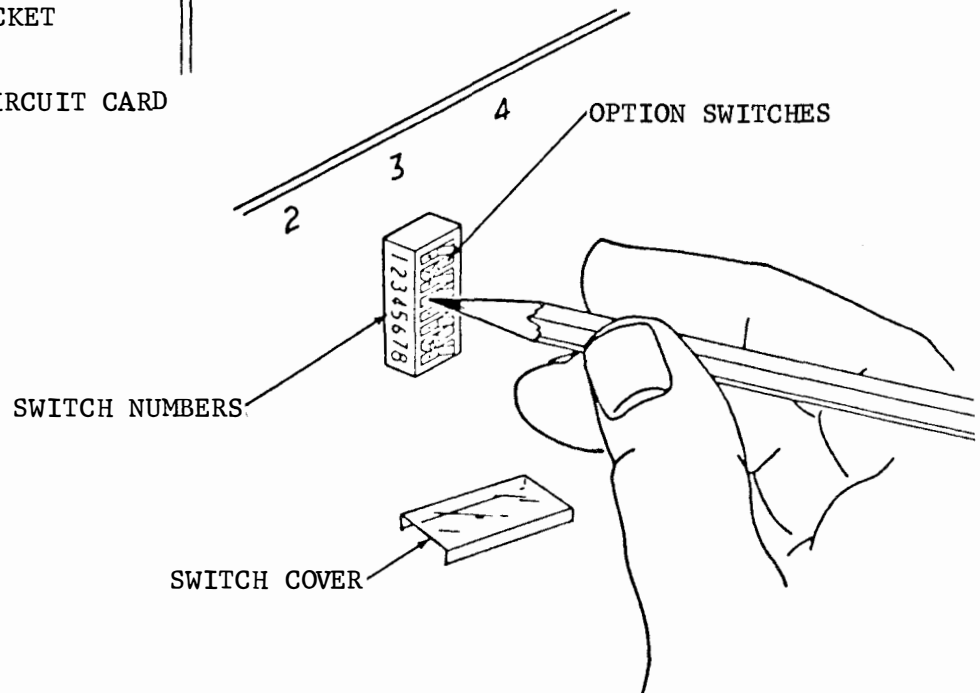

STEP 2. ACTIVATING OPTIONS

B. INSTALLATION (Continued)

2. Activating Options and Modifications (Continued)

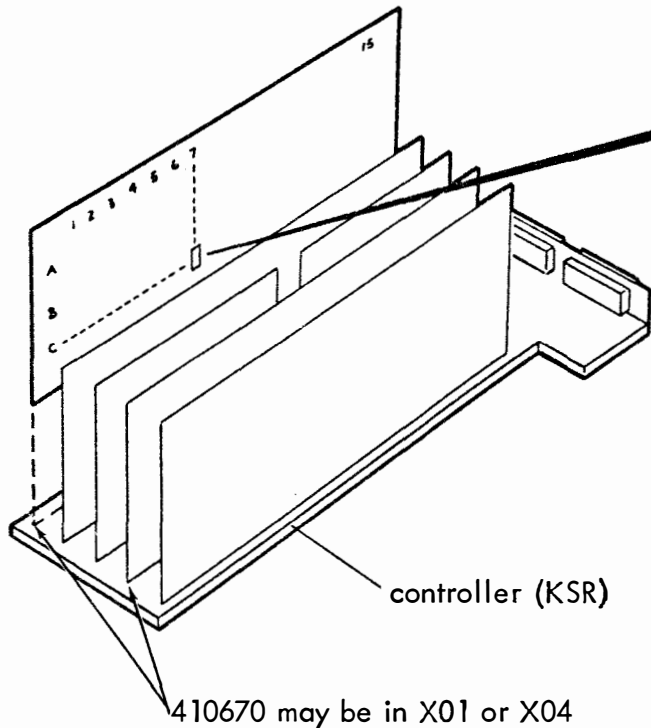

Note: Timer circuit card option 28 is shown on page 48.

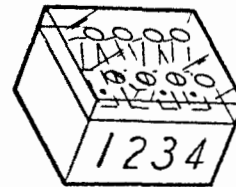

410670 - S/R, PTR, and Disconnect Circuit Card Options

		C-7			
		1	2	3	4
1. Interface to Printer					
a	EIA	○	—	●	—
b	SSI	●	—	○	— *

		C-7			
		1	2	3	4
2. S/R Send					
a	DC2 Sent Auto	—	●	—	—
b	DC2 Sent W/Message	—	○	—	— *

- Indicates dot end of rocker switch depressed (or on).
- Indicates blank end of rocker switch depressed (or off).
- Position of rocker switch does not affect option.
- * Factory programmed

B. INSTALLATION (Continued)

2. Activating Options and Modifications (Continued)

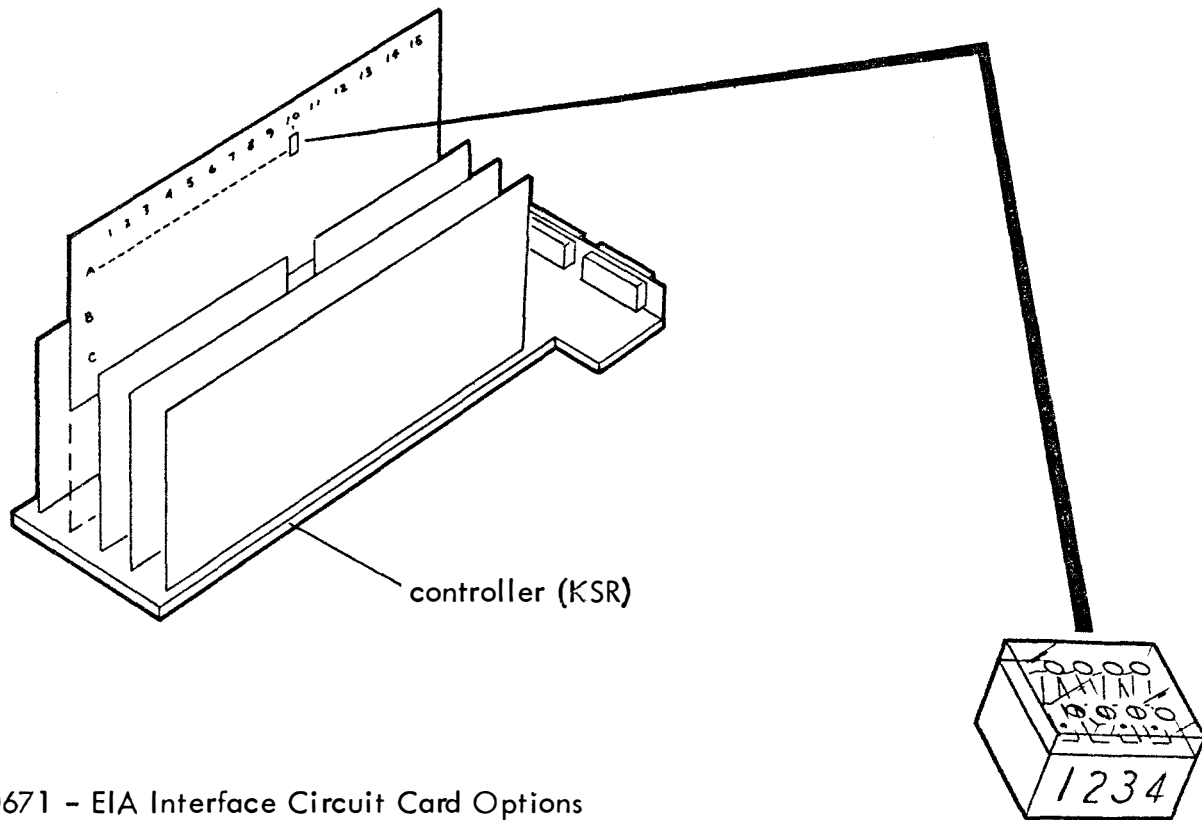

410671 - EIA Interface Circuit Card Options

3. EIA Send/Receive Data Baud Rate (See NOTE)		A-10			
		1	2	3	4
a	1050	●	○	○	—
b	1200	○	●	○	— *
c	2400 (Reserved for future use).	○	○	●	—

4. EIA Reverse Channel		A-10			
		1	2	3	4
a	Sent and Received	—	—	—	● *
b	Not Sent or Received	—	—	—	○

- Indicates dot end of rocker switch depressed.
- Indicates blank end of rocker switch depressed.
- Position of rocker switch does not affect option.
- * Factory programmed

NOTE: On RO Sets option 3 can only be activated by the service center.

B. INSTALLATION (Continued)

2. Activating Options and Modifications (Continued)

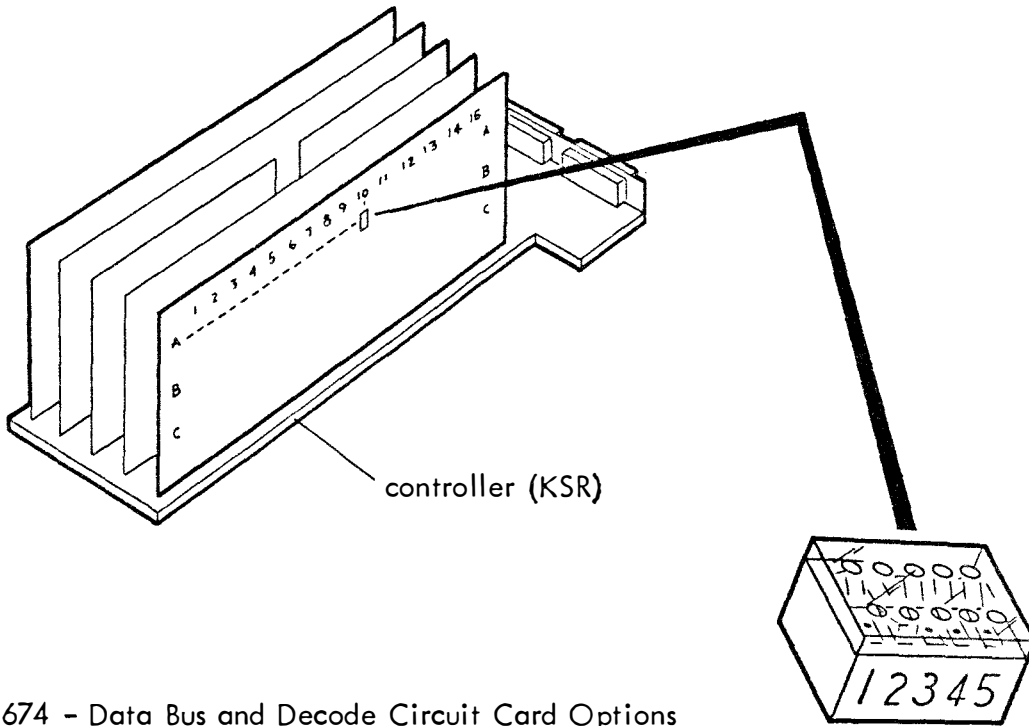

410674 - Data Bus and Decode Circuit Card Options

5. Response to Received Characters		A-10										
		1	2	3	4	5						
a	Reject Null	●	-	-	-	-						*
b	Accept Null	○	-	-	-	-						
c	Reject CR	-	●	-	-	-						*
d	Accept CR	-	○	-	-	-						
e	Reject Delete	-	-	●	-	-						*
f	Accept Delete	-	-	○	-	-						

6. Functions on Receive												
		1	2	3	4	5						
a	All Esc. Sequence Displayed as Received	-	-	-	○	-						
b	All Esc. Seq. are performed as Rec'd but not Displayed	-	-	-	●	-						*

7. Errored Character on Receive												
		1	2	3	4	5						
a	Not Displayed on Vertical Parity Error	-	-	-	-	●						
b	Displayed on Vertical Parity Error	-	-	-	-	○						*

B. INSTALLATION (Continued)

2. Activating Options and Modifications (Continued)

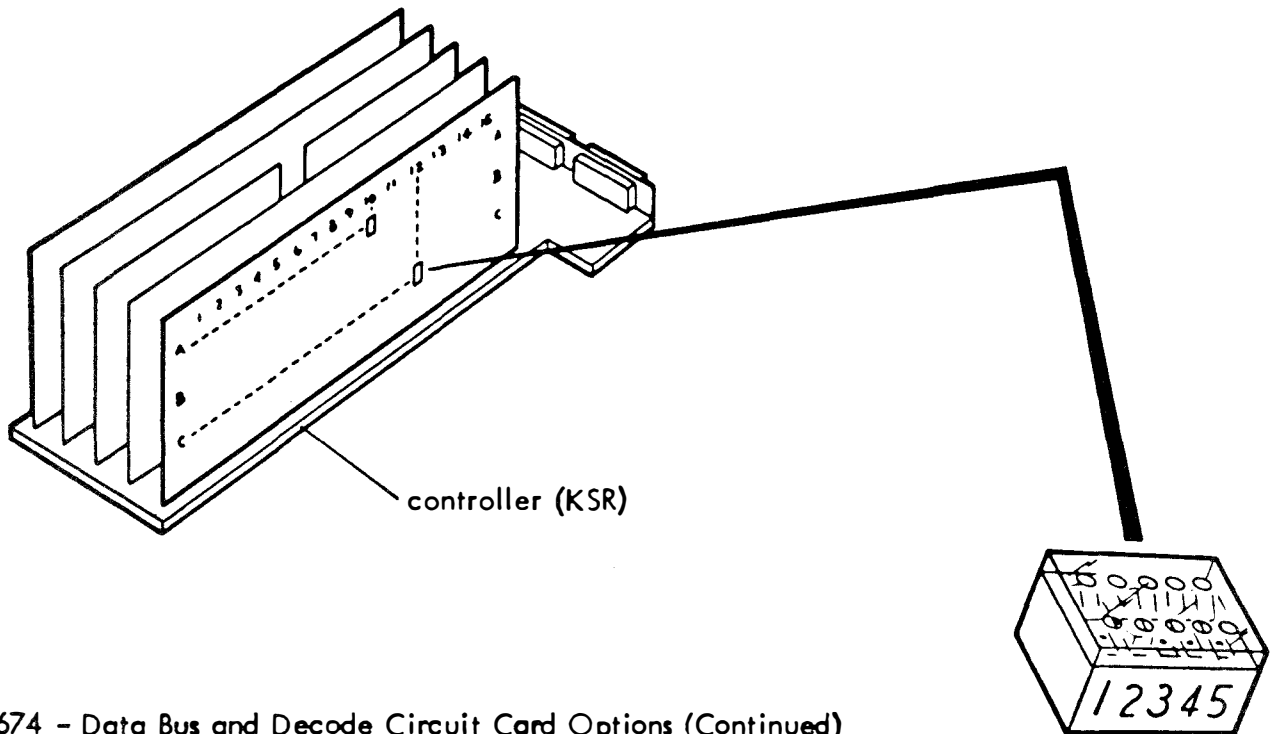

410674 - Data Bus and Decode Circuit Card Options (Continued)

8. Send Message Ending Character		C-12				
		1	2	3	4	5
a	End on FF	-	-	●	-	-
b	Do not End on FF	-	-	○	-	- *
c	End on ETX	●	-	-	-	- *
d	Do not End on ETX	○	-	-	-	-
e	End on EOT	-	●	-	-	- *
f	Do not End on EOT	-	○	-	-	-
g	End on GS	-	-	-	●	- *
h	Do not End on GS	-	-	-	○	-

9. Highlight						
a	Delimiters not Sent (Except in Form Send Mode)	-	-	-	-	●
b	Delimiters Sent (Modifies Option 13)	-	-	-	-	○ *

- Indicates dot end of rocker switch depressed.
- Indicates blank end of rocker switch depressed.
- Position of rocker switch does not affect option.
- * Factory programmed

B. INSTALLATION (Continued)

2. Activating Options and Modifications (Continued)

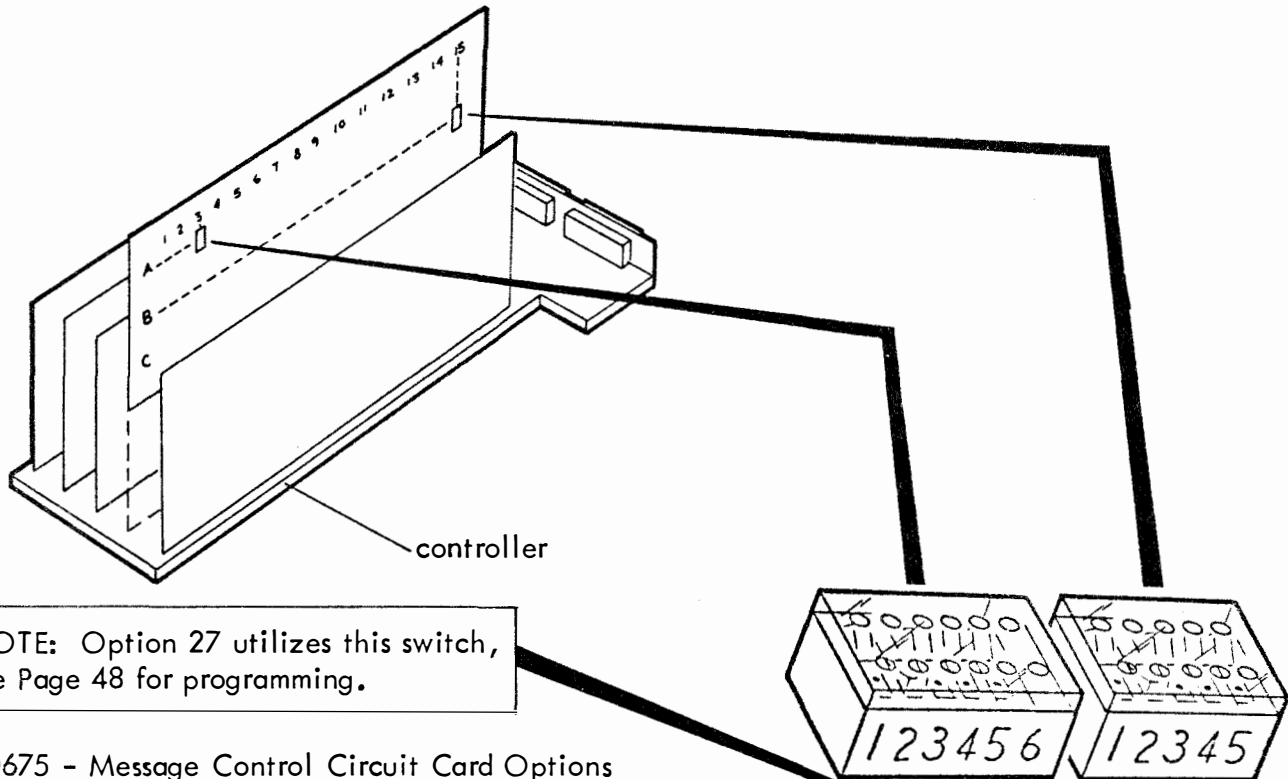

410675 - Message Control Circuit Card Options

10. Line Ending Sequence		A-3						B-15					
		1	2	3	4	5	6	1	2	3	4	5	
a	CR LF	-	-	-	-	○	-	●	●	○	○	○	
b	CR CR LF	-	-	-	-	○	-	○	○	●	●	●	*
c	LF	-	-	-	-	●	-	●	●	○	○	○	

11. Mode After Send													
		1	2	3	4	5	6	1	2	3	4	5	
a	Local	-	○	●	●	-	-						*
b	Receive	-	●	○	●	-	-						
c	External mode (must be used when 410678 card is present)	-	○	●	○	-	-						*

12. Form Enter													
		1	2	3	4	5	6	1	2	3	4	5	
a	Disabled in Local	●	-	-	-	-	-						
b	Enabled in Local	○	-	-	-	-	-						*

- Indicates dot end of rocker switch depressed.
- Indicates blank end of rocker switch depressed.
- Position of rocker switch does not affect option.
- * Factory programmed

B. INSTALLATION (Continued)

2. Activating Options and Modifications (Continued)

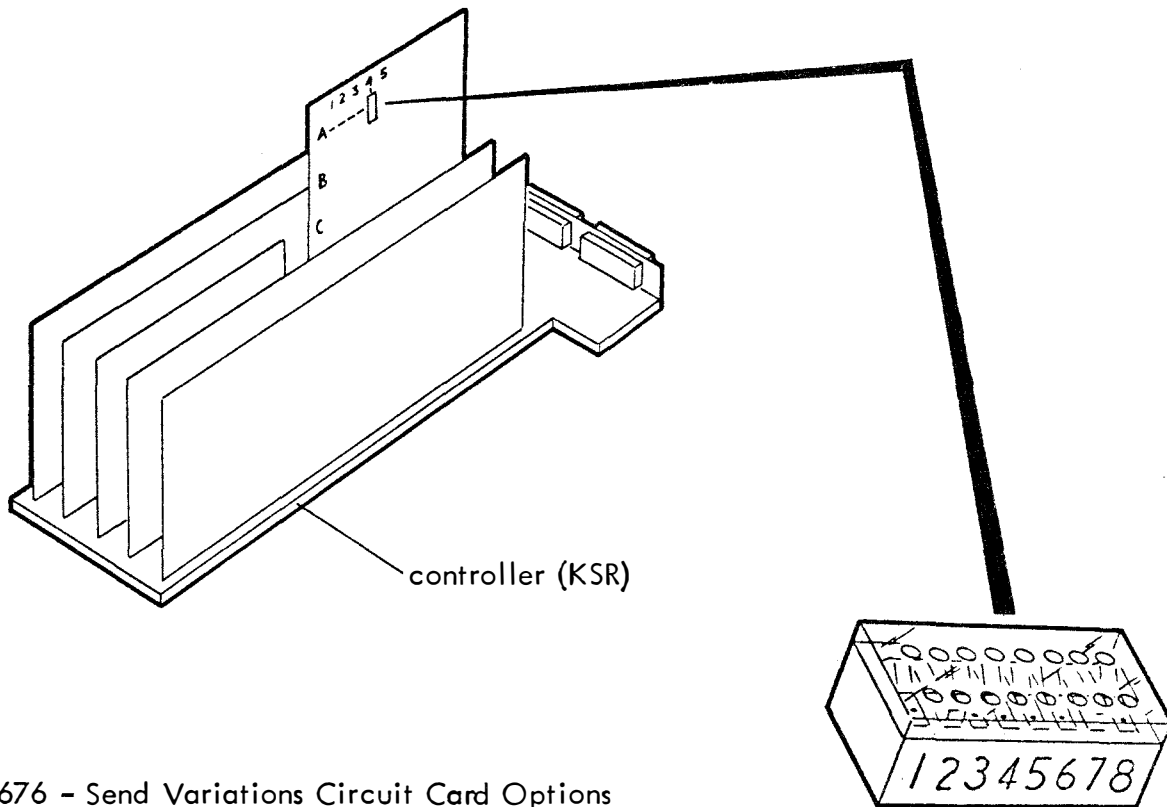

410676 - Send Variations Circuit Card Options

13. Send Variations (All without delimiters except as modified by option 9b. - See Note Below)		A-4							
		1	2	3	4	5	6	7	8
a	Send All as Displayed	●	○	●	●	●	●	●	○
b	Send All as Displayed with Unprotected HT to Space	●	○	●	●	●	●	●	●*
c	Send Protect as Space and Unprotected as Displayed	○	●	○	○	●	○	●	○
d	Send Protect as Space, Unprotected as Displayed and HT to Space	○	●	○	○	●	○	●	●
e	Send Protect as Delete, Unprotected as Displayed	○	●	○	○	○	○	●	○
f	Send Unprotected Only as Displayed	○	●	○	●	●	●	●	○
g	Send Unprotected Only and HT at End of Field	○	●	○	●	●	○	○	●
h	Send Unprotected Only with Unprotect HT to Space	○	●	○	●	●	●	●	●

- Indicates dot end of rocker switch depressed.
- Indicates blank end of rocker switch depressed.
- Position of rocker switch does not affect option.
- * Factory programmed

B. INSTALLATION (Continued)

2. Activating Options and Modifications (Continued)

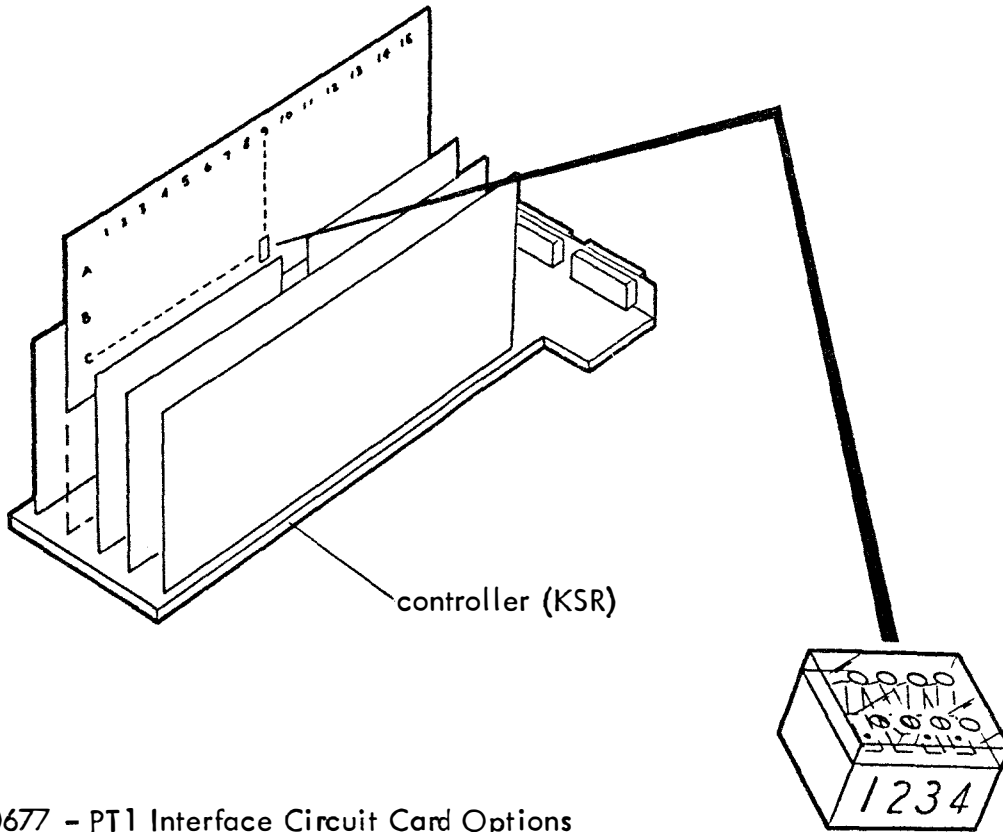

410677 - PT1 Interface Circuit Card Options

14. Receive Selectable		C-9			
		1	2	3	4
a	On	—	—	—	● *
b	Off	—	—	—	○

- Indicates dot end of rocker switch depressed.
- Indicates blank end of rocker switch depressed.
- Position of rocker switch does not affect option.
- * Factory programmed

B. INSTALLATION (Continued)

2. Activating Options and Modifications (Continued)

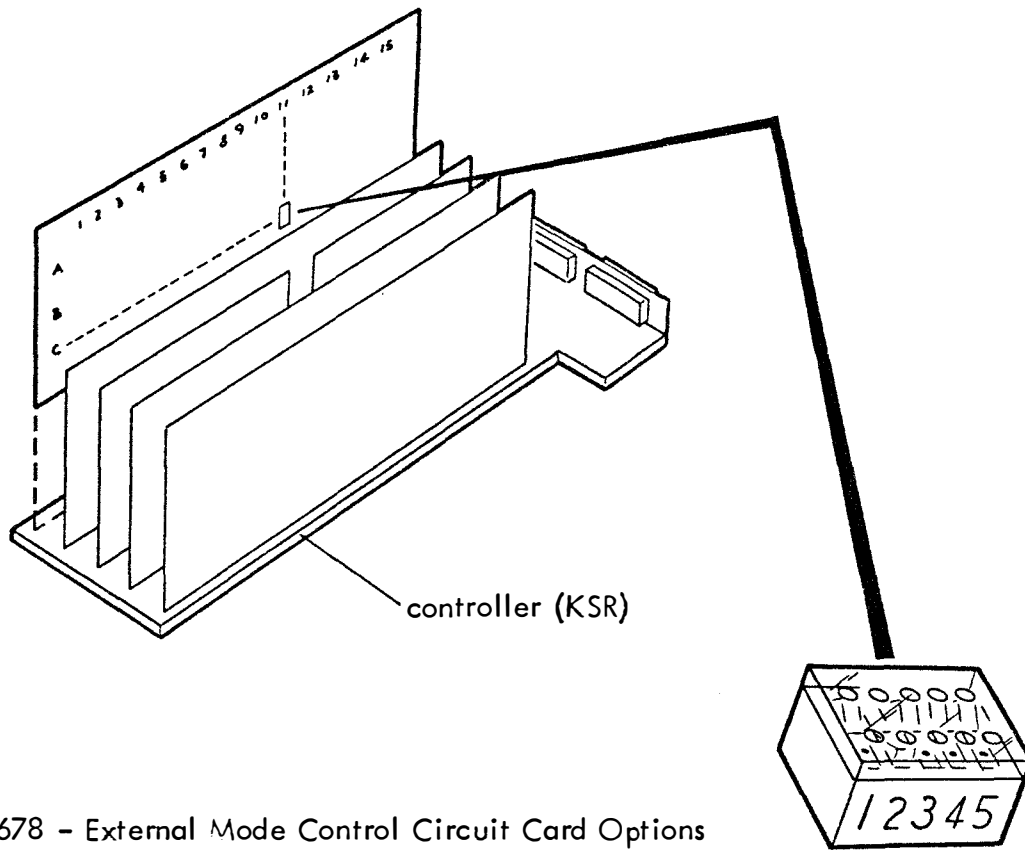

410678 - External Mode Control Circuit Card Options

15. Local and Send Mode Override		C-11				
		1	2	3	4	5
a	Goes from Send or Local to Receive	-	-	-	●	-
b	Stays in Local or Send	-	-	-	○	-

16. Mode After TDA (11. c. must be implemented)						
		1	2	3	4	5
a	Goes to Receive	●	○	-	-	-
b	Goes to Local	○	●	-	-	-
c	Cursor Goes to Home	-	-	●	-	○
d	Cursor Stays at Message End	-	-	○	-	●

- Indicates dot end of rocker switch depressed.
- Indicates blank end of rocker switch depressed.
- Position of rocker switch does not affect option.
- * Factory programmed

B. INSTALLATION (Continued)

2. Activating Options and Modifications (Continued)

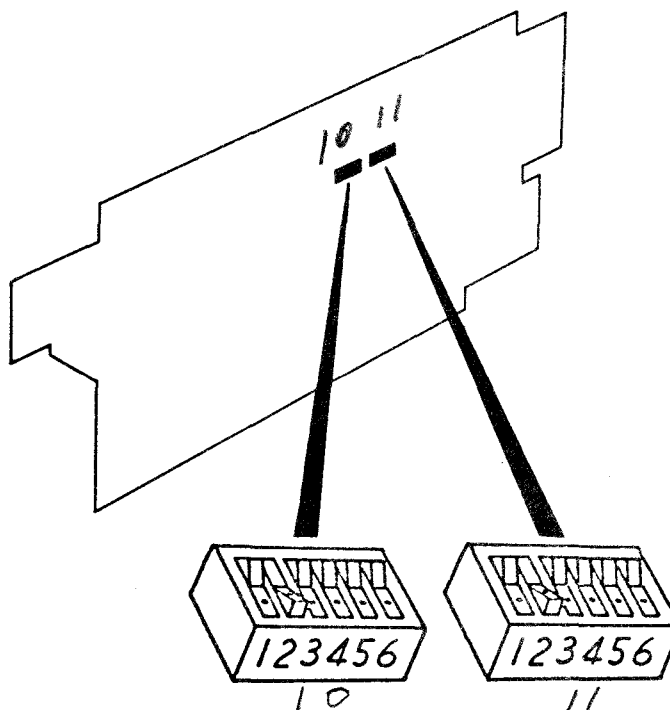

410640 — Printer Logic Circuit Card

17. Printer Margin and Form Length														
		1	2	3	4	5	6	1	2	3	4	5	6	
c	Last Character on 80th Column							○	●	●	○	-	-	*
d	Last Character on 79th Column							○	●	●	●	-	-	
d	Last Character on 78th Column							●	○	○	●	-	-	
d	Last Character on 77th Column							●	○	●	○	-	-	
d	Last Character on 76th Column							●	○	●	●	-	-	
d	Last Character on 75th Column							●	●	○	●	-	-	
d	Last Character on 74th Column							●	●	●	○	-	-	
d	Last Character on 73rd Column							●	●	●	●	-	-	

Note: Options 17a, 17b, 17e, and 17f are for future use

18. Printer Paper Feed Out														
		1	2	3	4	5	6	1	2	3	4	5	6	
a	No Paper Feed Out	●	-	-	-	-	-	-	-	-	-	-	○	
b	Paper Feed Out on DCD Loss - 16 Lines	○	-	-	-	-	-	-	-	-	-	-	○	
c	Paper Feed Out on DCD Loss or ETX	○	-	-	-	-	-	-	-	-	-	-	●	*

- Indicates dot end of rocker switch depressed. *ON.*
- Indicates blank end of rocker switch depressed.
- Position of rocker switch does not affect option.
- * Factory programmed

B. INSTALLATION (Continued)

2. Activating Options and Modifications (Continued)

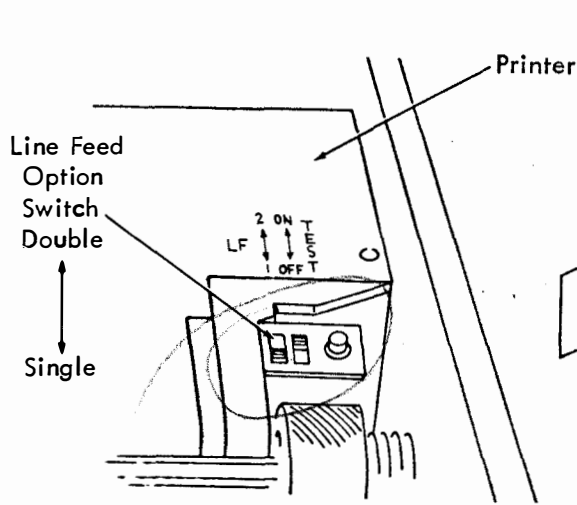

Figure 1

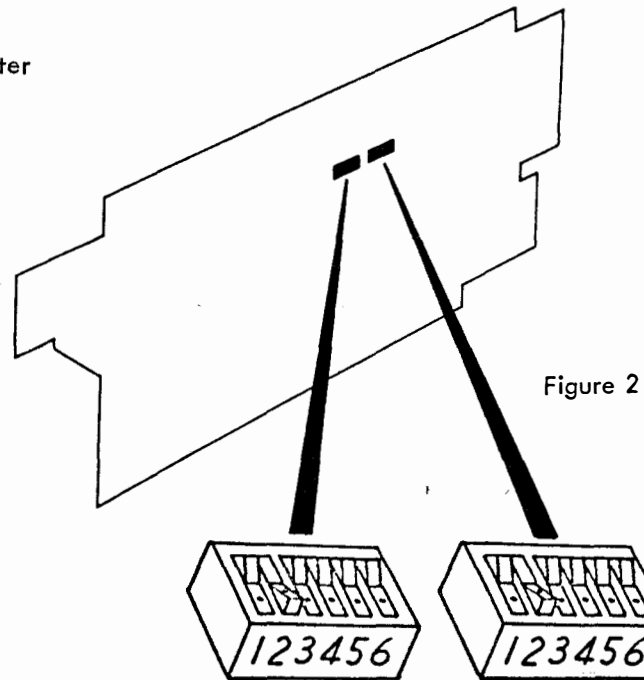

Figure 2

410640 — Printer Logic Circuit Card

19. Printer Errored Character Symbol														
		1	2	3	4	5	6	1	2	3	4	5	6	
a	Printed on Even Parity Error	-	-	-	●	○	-							*
b	Printed on Odd Parity Error	-	-	-	○	●	-							
c	Not Printed on Parity Error	-	-	-	●	●	-							
E	<input checked="" type="checkbox"/> Printers with 96 Character Set	-	○	●	-	-	-							
D	<input checked="" type="checkbox"/> Printers with 64 Character Set	-	●	○	-	-	-							
f	Printers with Extended ASCII Character Set	-	○	○	-	-	-							

20. Line Feed on Printer														
		1	2	3	4	5	6	1	2	3	4	5	6	
a	Single													*
b	Double	(See Figure 1 Above)												

21. Foldover on Up-Low Printer														
		1	2	3	4	5	6	1	2	3	4	5	6	
a	Lower Case and Upper Case Print							-	-	-	-	○	-	*
b	Lower Case Prints as Upper Case							-	-	-	-	●	-	

- Indicates dot end of rocker switch depressed.
- Indicates blank end of rocker switch depressed.
- Position of rocker switch does not affect option.
- * Factory programmed

B. INSTALLATION (Continued)

2. Activating Options and Modifications (Continued)

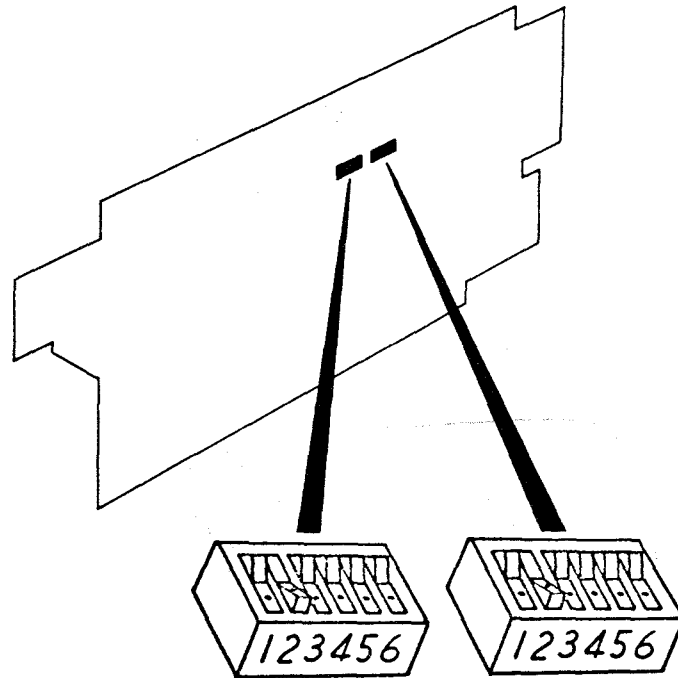

410640 — Printer Logic Circuit Card

22. Foldover on Mono Case Printer													
		1	2	3	4	5	6	1	2	3	4	5	6
a	Lower Case Not Folded Over							-	-	-	-	○	-
b	Lower Case Printed as Upper Case							-	-	-	-	●	-

23. Extended ASCII on Printer (Extended ASCII)													
		1	2	3	4	5	6	1	2	3	4	5	6
a	†Prints Extended ASCII Characters (No Parity Check)				0	0							
b	Does Not Print Extended Characters (See 19a, b, or c)												

- Indicates dot end of rocker switch depressed.
- Indicates blank end of rocker switch depressed.
- Position of rocker switch does not affect option.
- * Factory programmed
- † Option 23a Requires Local System Engineering



B. INSTALLATION (Continued)

2. Activating Options and Modifications (Continued)

Note: Options 24 and 25 are programmed at the service center only.

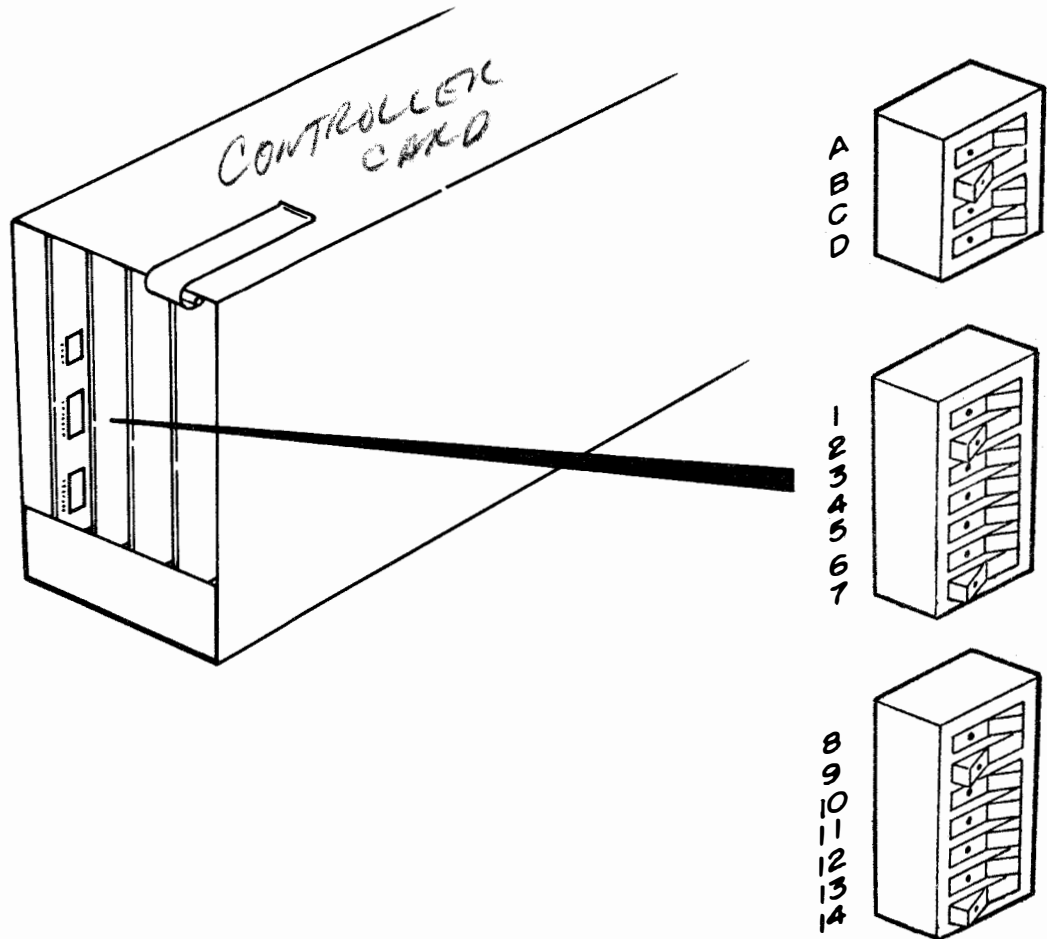

26. Trans Start		A	B	C	D	1234567	891011121314
a	14 bit disc call code programmed	—	—	—	—	● Mark or	○ Space
b	14 bit disc call code not programmed	—	—	—	—	● ● ● ● ● ● ● ●	● ● ● ● ● ● ● ● *
c	Program code sent	—	—	—	○		
d	Program code not sent	—	—	—	●		
Internal Test Generator							
	1050 wpm For service center only.	●	○	○	—		
	1200 wpm Must conform to Option 3	○	●	○	—		*
	2400 wpm which is programmed at the Service Center	○	○	●	—		

B. INSTALLATION (Continued)

2. Activating Options and Modifications (Continued)

Note: The TP410670 card may be in position X01 or X04 depending on the controller arrangement.

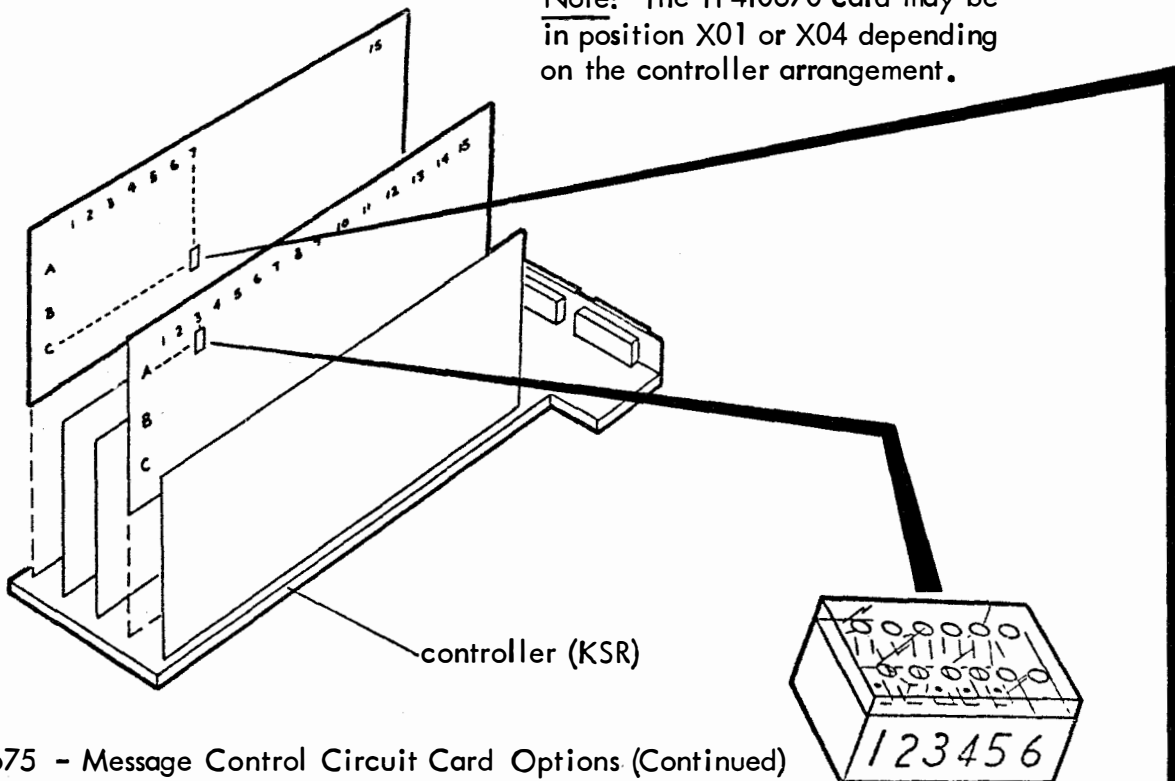

410675 - Message Control Circuit Card Options (Continued)

		A3					
		1	2	3	4	5	6
27.	Message Start						
a	Home on Transmit	-	-	-	-	-	●
b	Send From Cursor	-	-	-	-	-	○ *

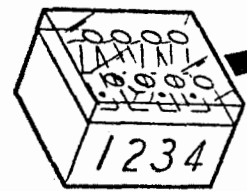

410670 - S/R, PTR, and Disconnect Circuit Card Options (Continued)

		C-7			
		1	2	3	4
28.	Disconnect on Loss of Carrier				
a	Disconnect After 45 Seconds	-	-	-	○ *
b	Does Not Disconnect - Timer Disabled	-	-	-	●

- Indicates dot end of rocker switch depressed.
- Indicates blank end of rocker switch depressed.
- Position of rocker switch does not affect option.
- * Factory programmed

B. INSTALLATION (Continued)

3. Assembly and Internal Connections
ASSEMBLY - Operator Console (OPCON)

Install OPCON in sequence shown:

- ① Position OPCON so that connectors are aligned and latches on left and right side are fully engaged.

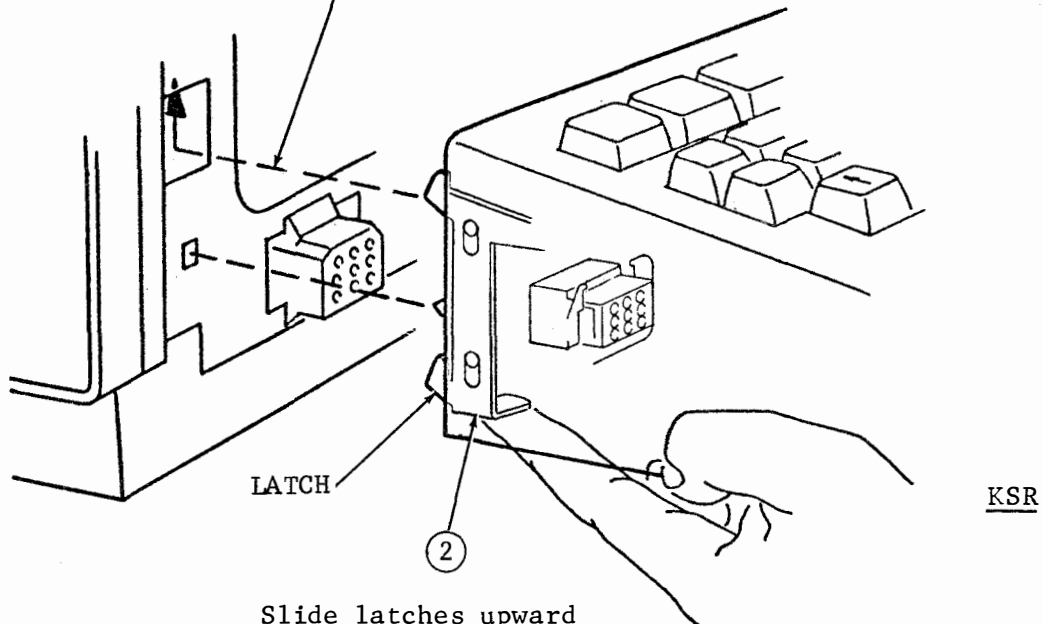

Slide latches upward and check that OPCON is firmly attached on both sides before releasing.

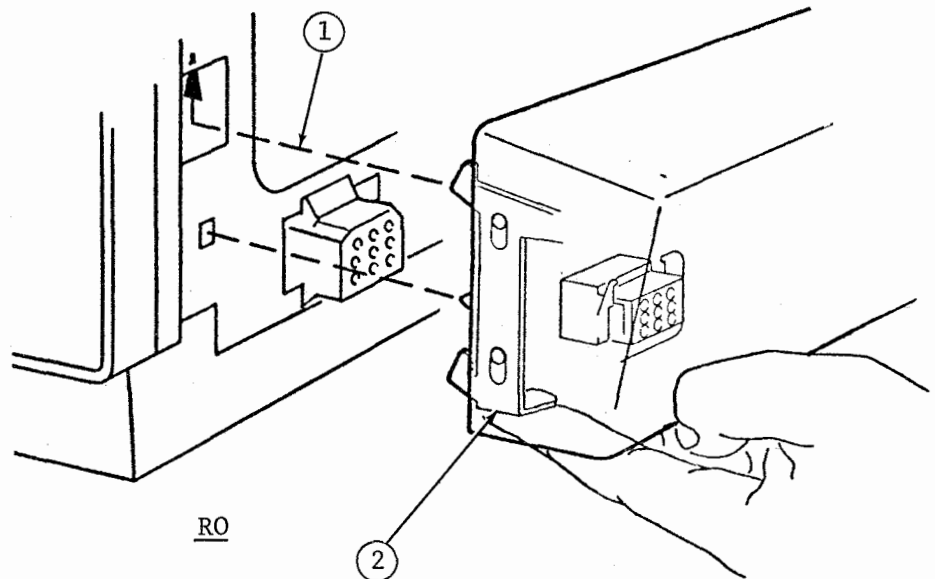

B. INSTALLATION (Continued)

3. Assembly and Internal Connections
ASSEMBLY - PRINTER

Lubricate (per Section H.) and then
Install printer in sequence shown:

- ① Open cover of empty printer cabinet by releasing the left and right latches inward and tilt back.

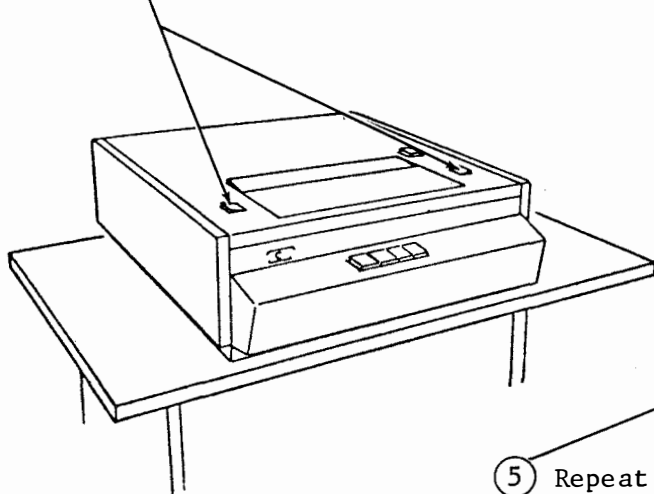

- ② **CAUTION**
Printer tracks are under tension. Release carefully as shown:

- ③ Hold down while removing shipping screw.
④ Raise slowly.

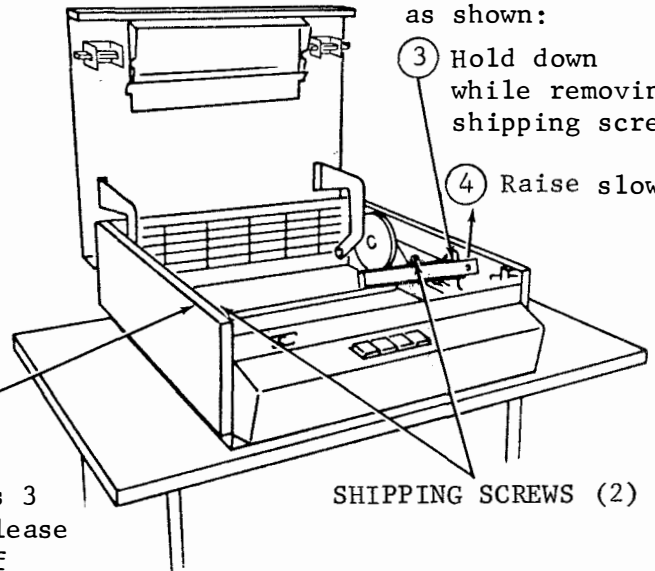

- ⑤ Repeat Steps 3 and 4 to release left side of track assembly.

SHIPPING SCREWS (2)

RETAINER
DETENTS (2)

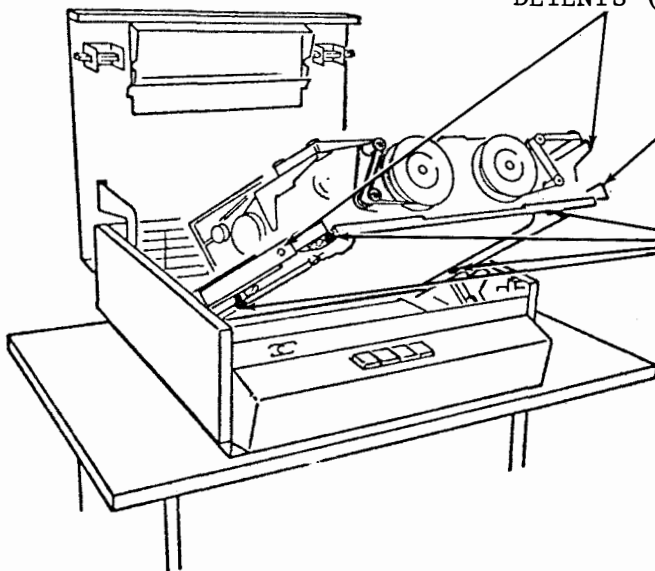

- ⑥ Slide printer carefully into tracks until retainer detents are seated.

- ⑦ Release 4 immobilizing screws (black) by backing off 4 full turns (CCW) from fully tightened position. Use short screwdriver.

See next page for remaining
steps in printer installation.

B. INSTALLATION (Continued)

3. Assembly and Internal Connections
ASSEMBLY - PRINTER (Continued)

⑧ Install ribbon according to procedures in How To Operate manual using ribbon supplied.

⑨ Connect AC Power Cable

⑪ Depress the left and right unlatchlever and push down on printer unit until it latches.

⑩ Connect SSI cable to printer cable.

⑫ Connect cover interlock switch cable to printer.

⑬ Load paper in the printer according to procedures in How To Operate manual using paper roll and spindle provided.

⑮ Connect printer and OPCON cables from pedestal.

⑭ Close cover.

Note: Refer to Page 53 for connection of these cables in the R0 pedestal.

Note: Refer to Page 52 for other arrangements.

⑯ Plug in AC power cord.

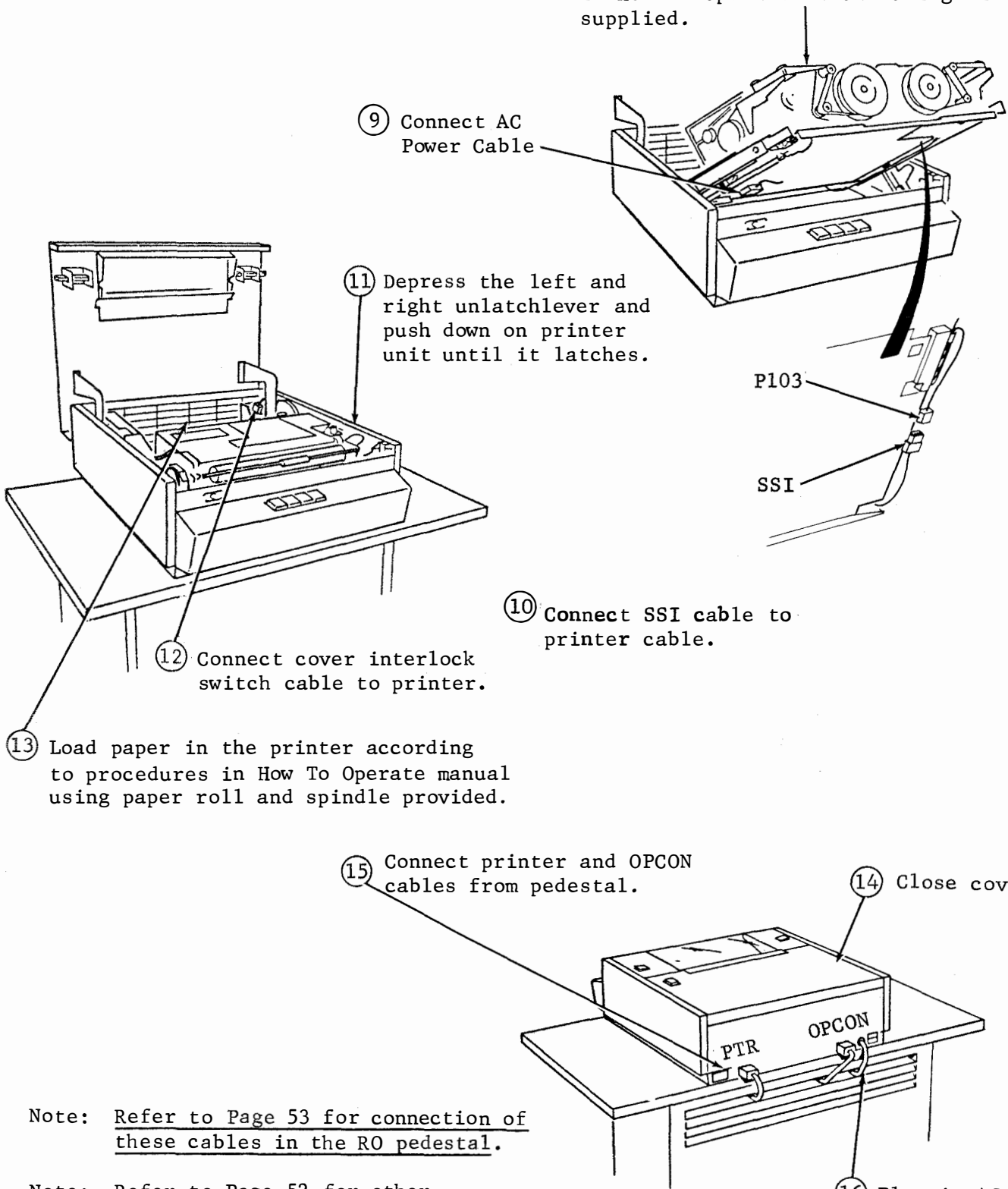



B. INSTALLATION (Continued)

3. Assembly and Internal Connections
(Continued)
ASSEMBLY - MONITOR

Install the Monitor in the sequence shown:

- ① Place the Monitor on its corresponding posts (there is no locking device associated with the monitor support posts i.e. it can be lifted off without releasing any latches).
- ② Tilt the Monitor back and remove the 341719 Packing Clip from the tube tilt mechanism. Retain the clip for future repacking.
- ③ Install the plastic bottom plate (packed separately). Snaps on with 4 studs that are part of the bottom plate.

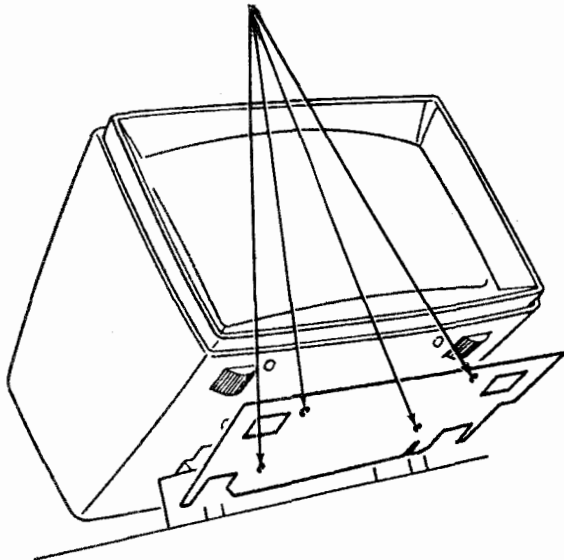
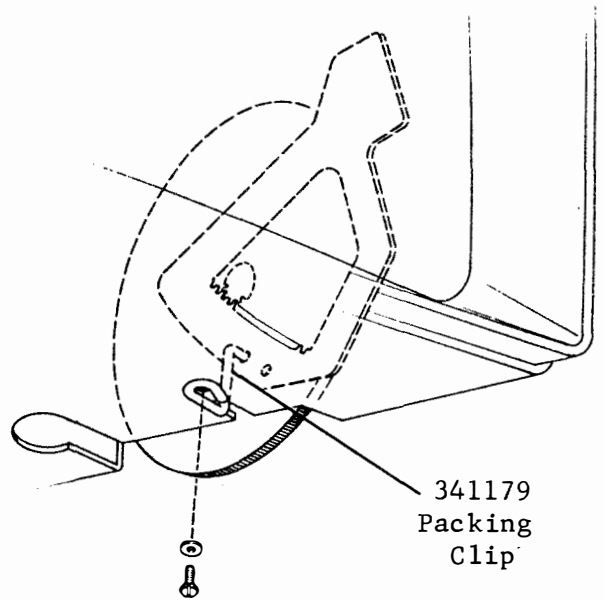
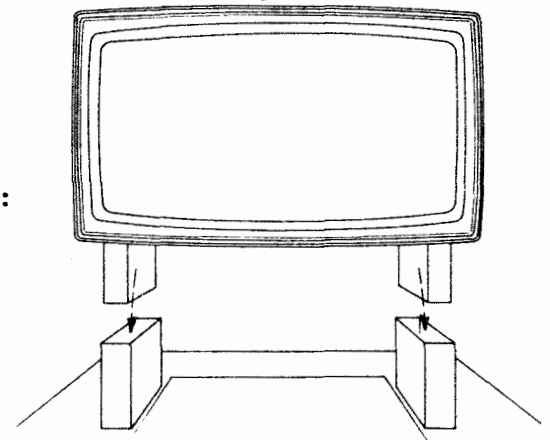

B. INSTALLATION (Continued)

3. Assembly and Internal Connections (Continued)

Note: See Page 56 for AC power connections to convenience strip in pedestal.

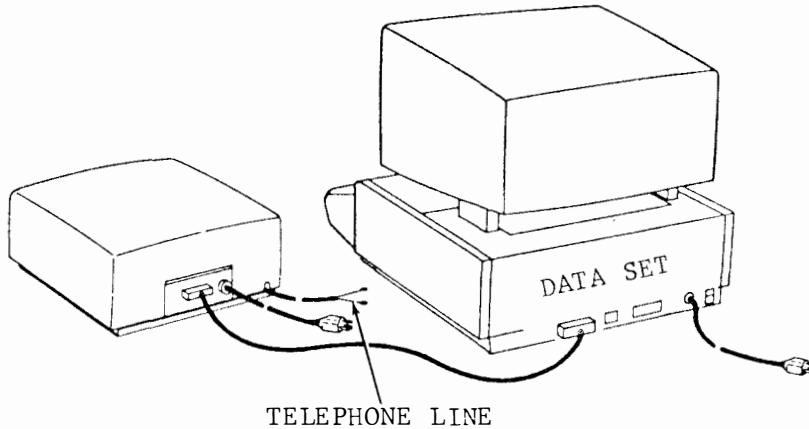

Model 40
KSR (Keyboard Display)

NOTE: All arrangements shown are for use in Switched Network applications using a Bell System data set or equivalent.

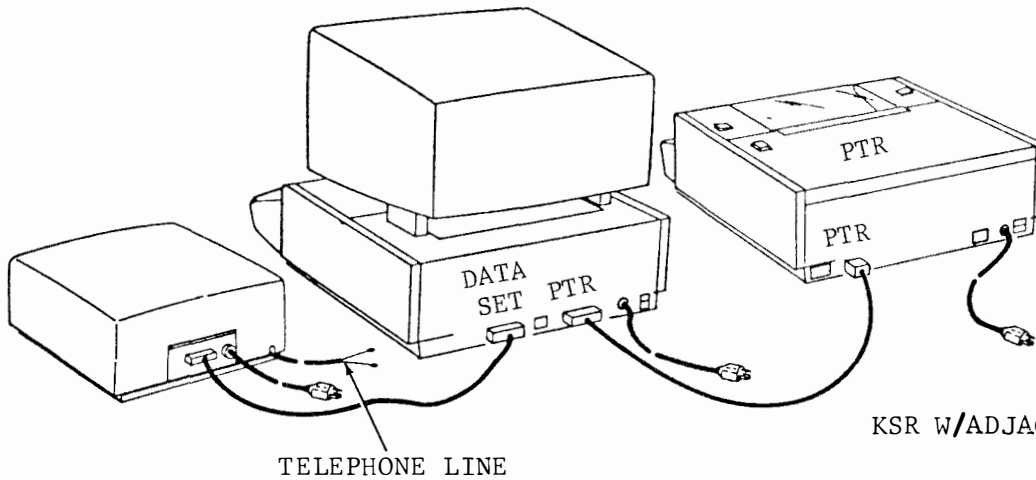

KSR W/ADJACENT PRINTER

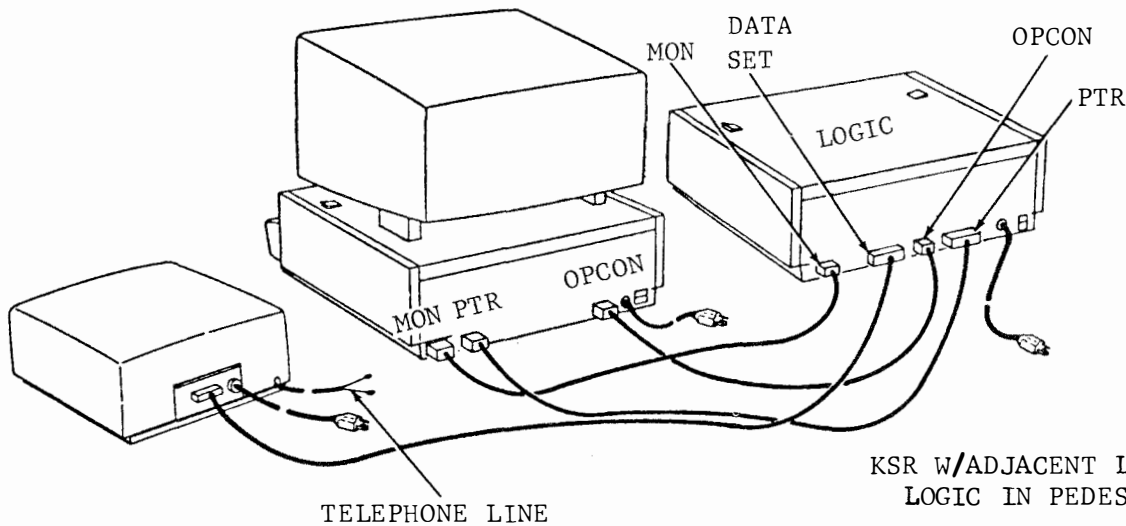

KSR W/ADJACENT LOGIC OR
LOGIC IN PEDESTAL

B. INSTALLATION (Continued)

3. Assembly and Internal Connections

Model 40 RO Printer Set

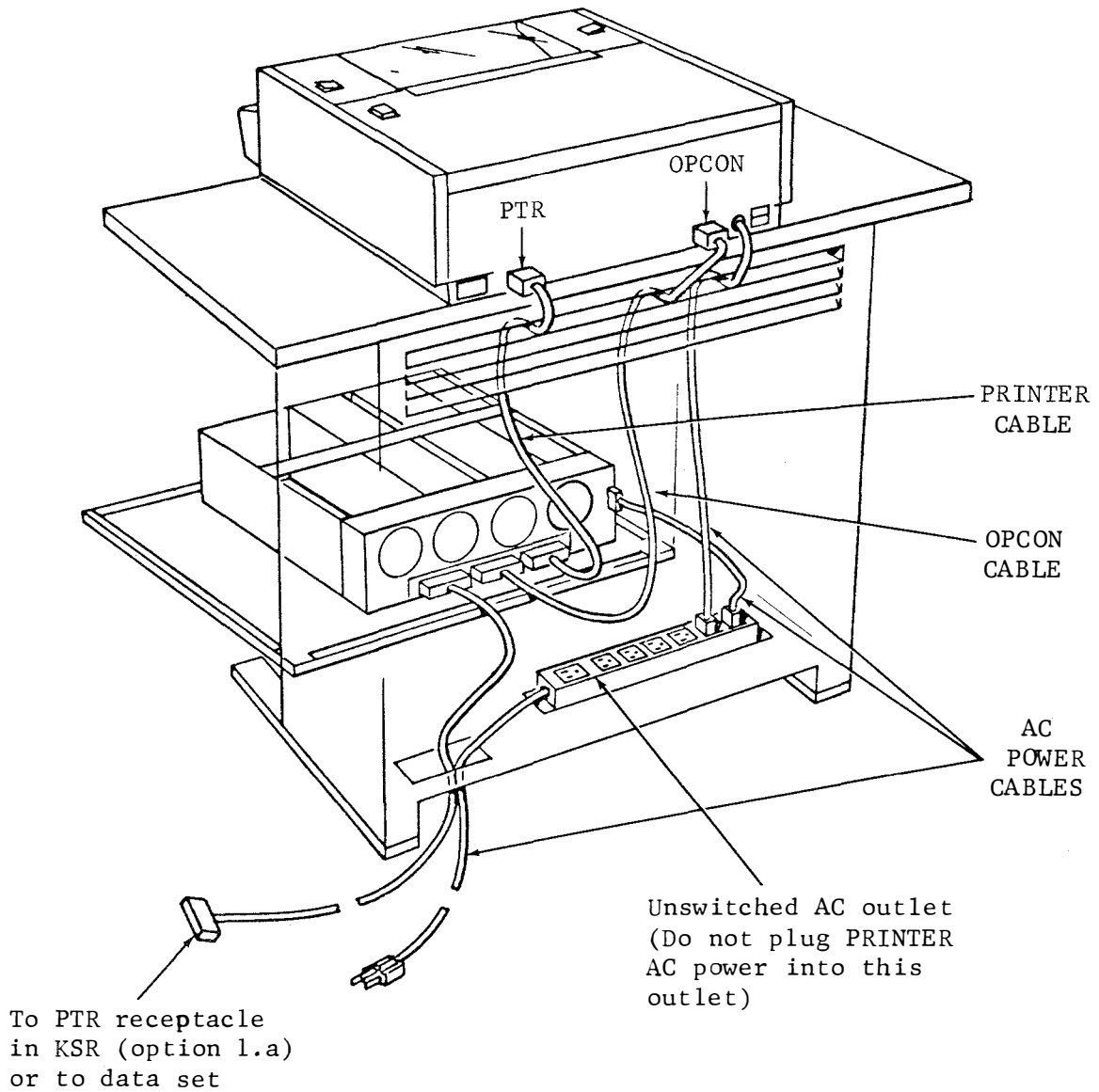

B. INSTALLATION (Continued)

3. Assembly and Internal Connections (Continued)

Model 40 KSR (PTI Keyboard Display)

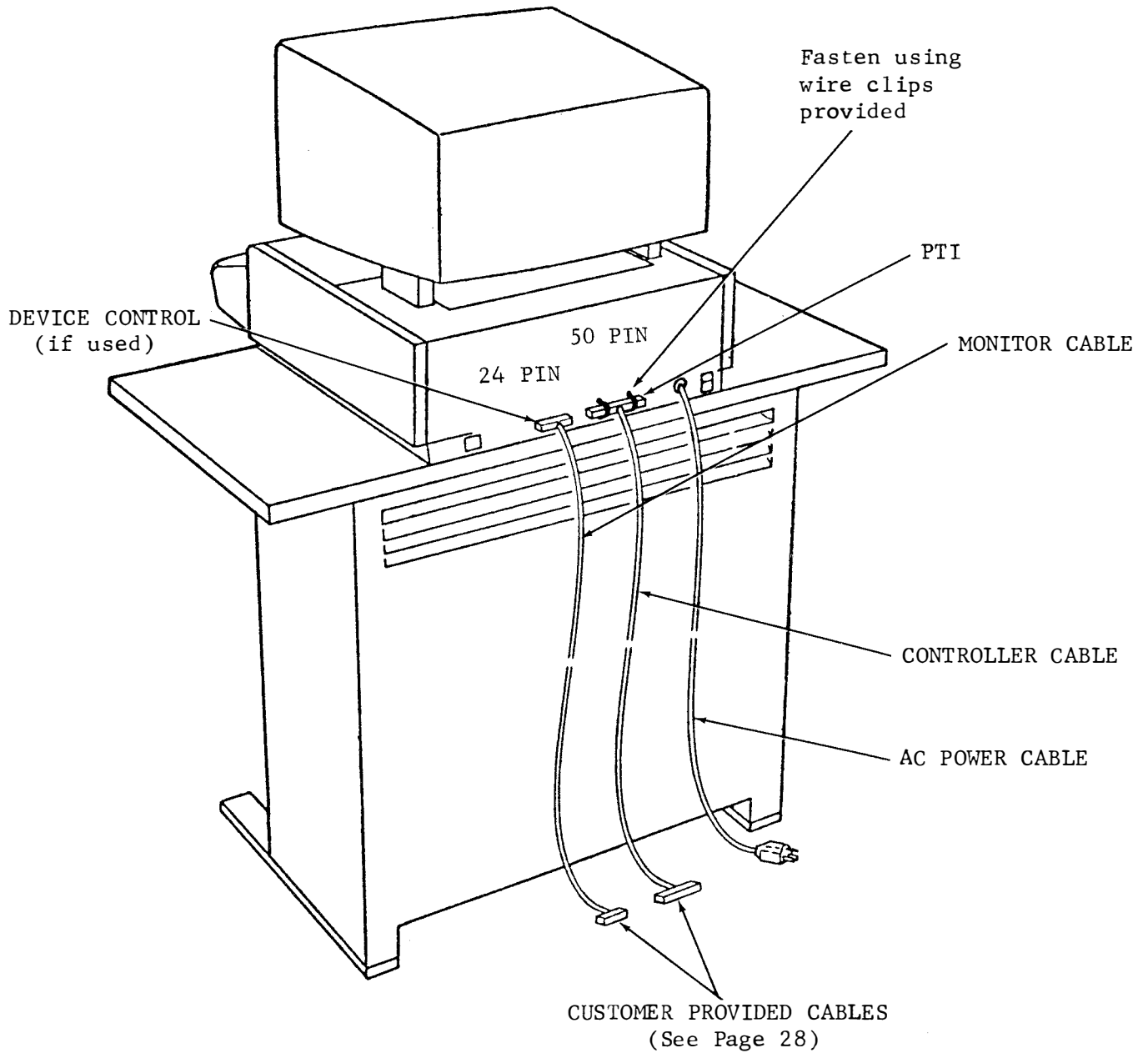

B. INSTALLATION (Continued)

4. Interface Connections and Suggested Data Set Locations

Bell System 202D or 202R or Equivalent Data Set Installation

1. Remove data set cover by loosening 4 screws.
2. *Separate the pan from the electrical assembly by removing 4 screws from the bottom (retain screws).
*The following procedure applies to 202D Data Sets only. Proceed to step 7 for 202R Data Set.
3. Remove the data set mounting bracket from the pedestal door (4 screws). Use a right angle screwdriver to loosen the 2 screws inside the electronic package enclosure. If necessary, remove one or more circuit cards to create accessibility.
4. Assemble the pan to the mounting bracket so that the connector end of the data set faces the front when the pedestal front panel is opened.
5. Reassemble the electrical assembly to the pan (4 screws through access openings in bracket).
6. Mount the entire assembly to the pedestal door and module frame (4 screws), and replace circuit cards (if removed earlier - step 3).
7. 202R Data Set only
With the cover removed (1), mount the data set to the bracket in the pedestal with 4 screws so that the connector end of the data set faces the front when the pedestal front panel is opened.
8. Reinstall data set cover.

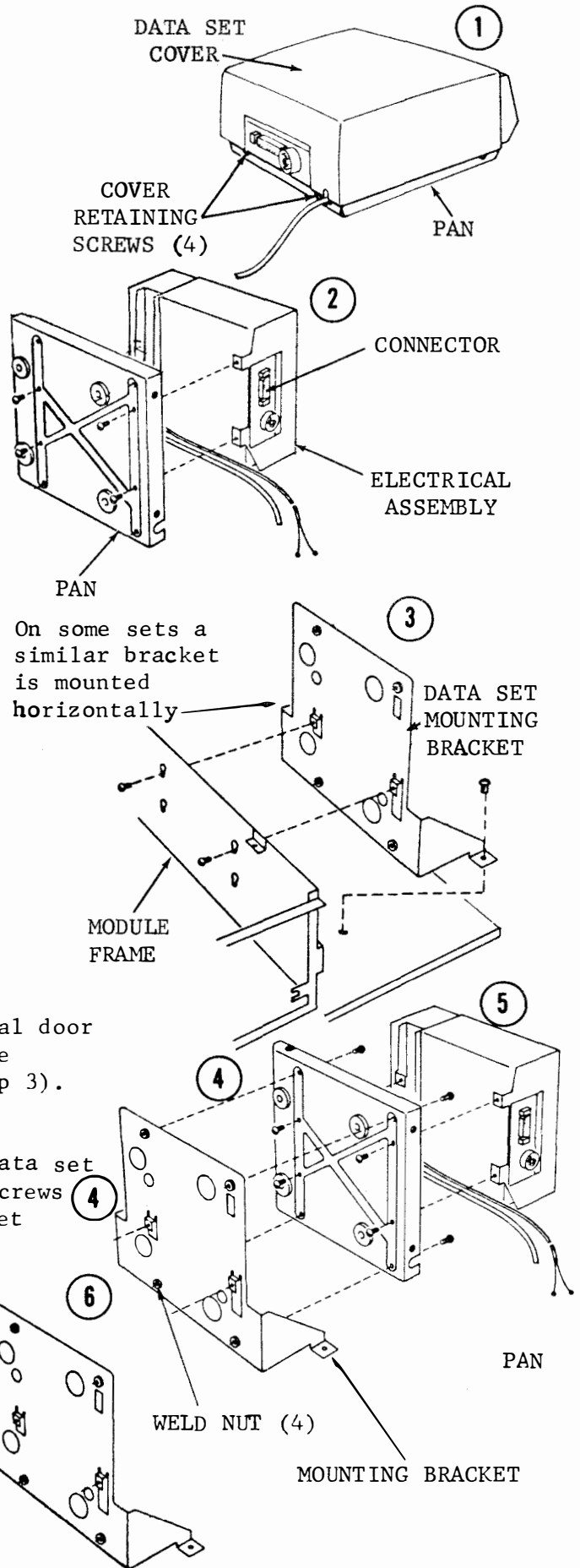

B. INSTALLATION (Continued)

4. Interface Connections and Suggested Data Set Locations (Continued)

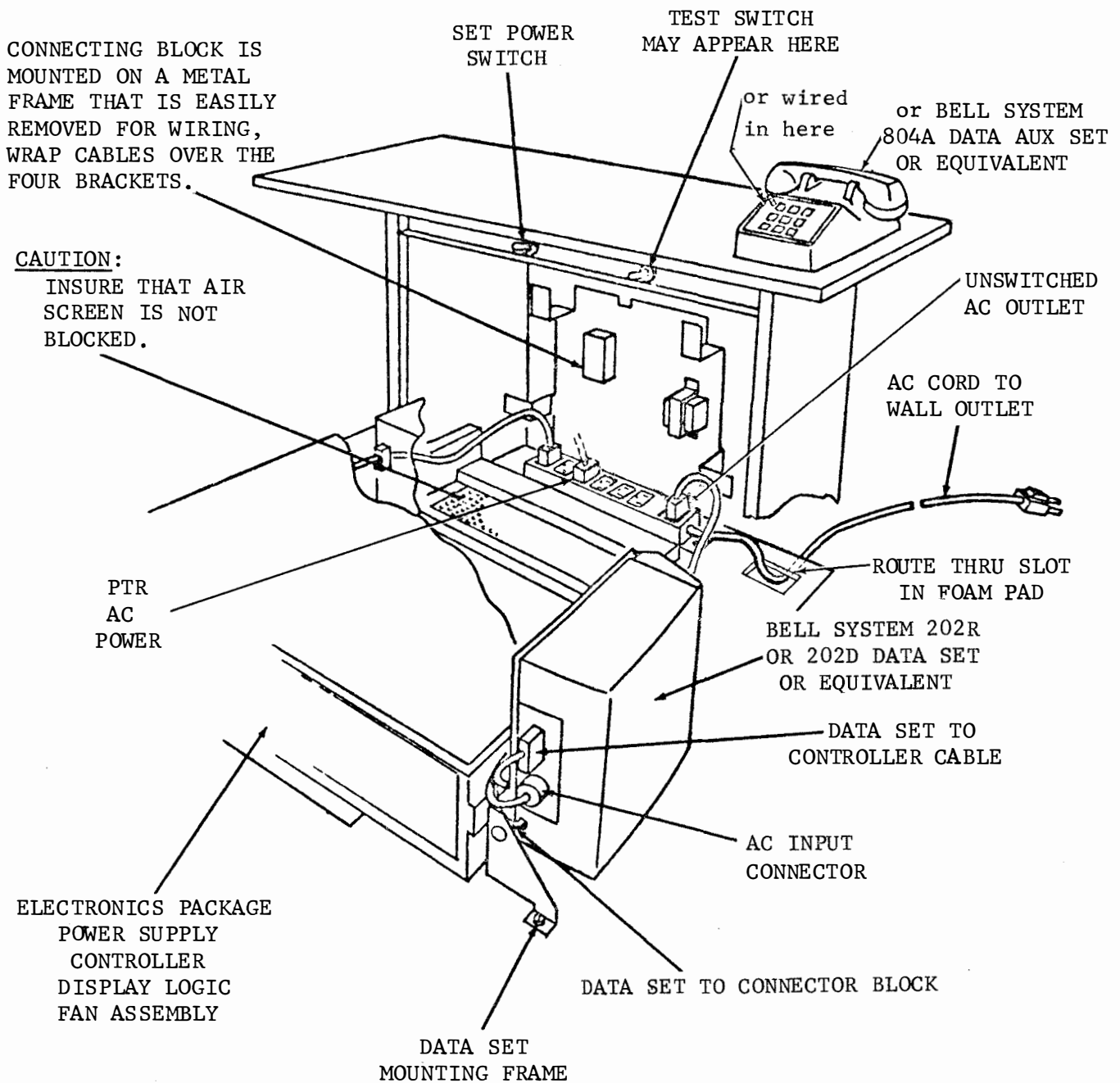

B. INSTALLATION (Continued)

3. Assembly and Internal Connections (Continued)

Model 40 KSR (S.N. Keyboard Display With Printer Under Monitor)
(Showing Bell System 202R or Equivalent)

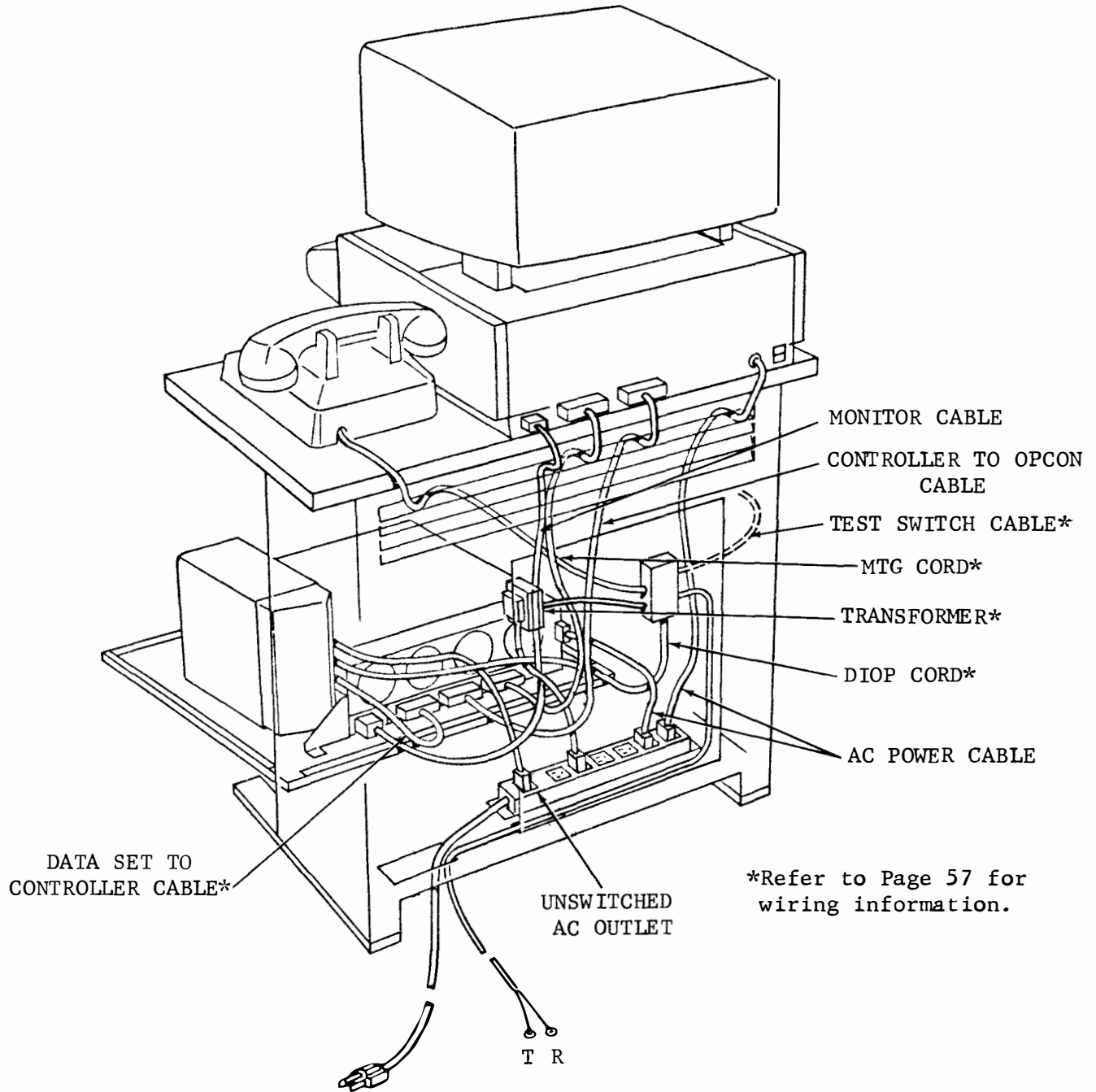



B. INSTALLATION (Continued)

4. Suggested Data Set Installation (Bell System or Equivalent)

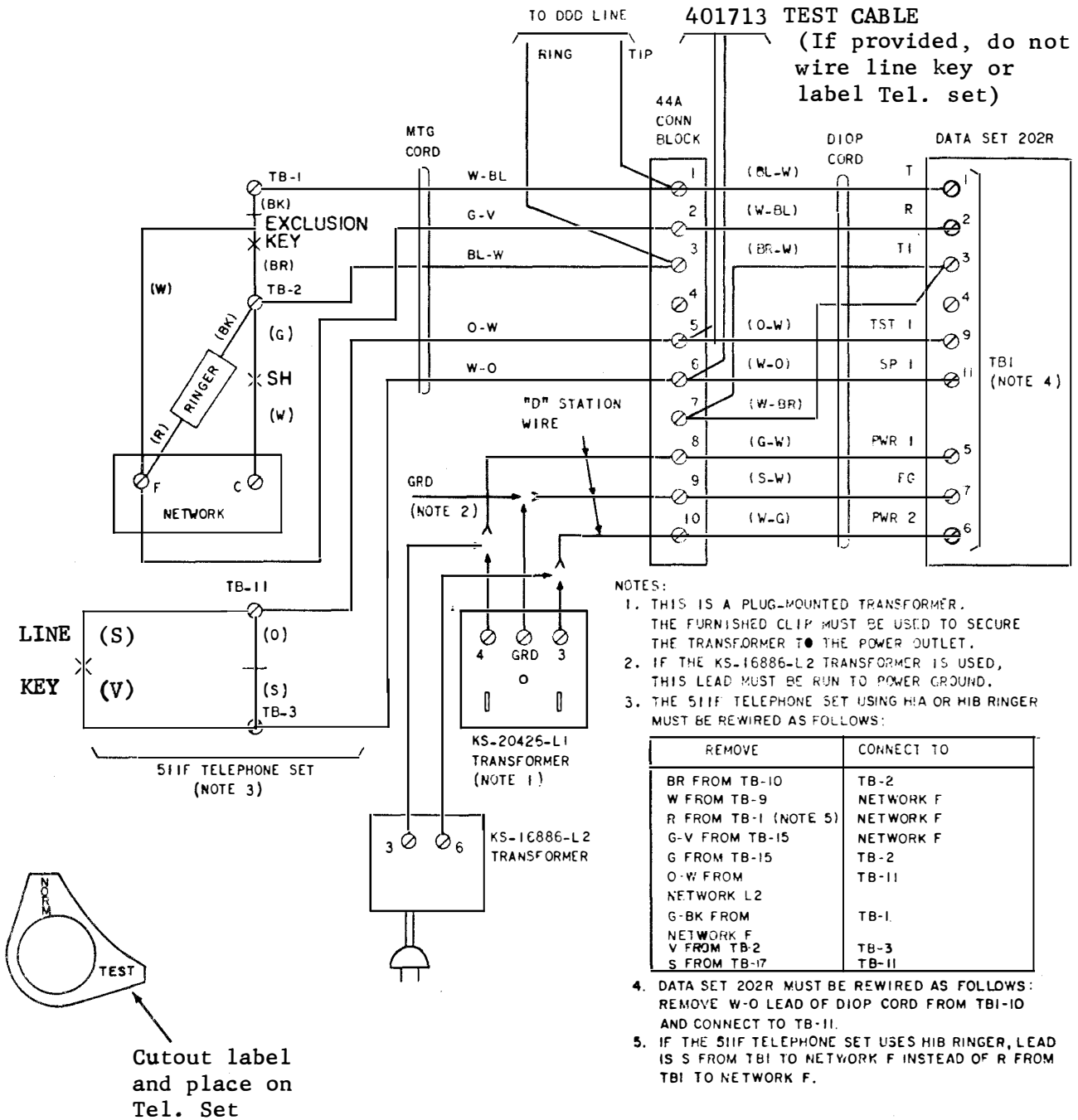

Two-Wire DDD Using a Bell System 511F Telephone Set or Equivalent

B. INSTALLATION (Continued)

4. Interface Connections (Continued)

Omitted in this issue.

B. INSTALLATION (Continued)

4. Interface Connections (Continued)

Omitted in this issue.

B. INSTALLATION (Continued)

5. Terminal Placement and Leveling

Placement

Leave at least 4 inches between back of the set and wall for ventilation and monitor access.

Level the set in its installed area by using the adjusting screws located in back of the pedestal.

CAUTION: USE CARE WHEN MOVING ASSEMBLED SETS SINCE UNITS ARE NOT FASTENED TO THE PEDESTAL. WHEN ADJUSTING LEVELING FEET TILT PEDESTAL TO LEFT OR RIGHT SIDE. DO NOT TILT TO THE FRONT OR PEDESTAL DOOR CONTAINING ELECTRONICS PACKAGE MAY FALL OPEN.

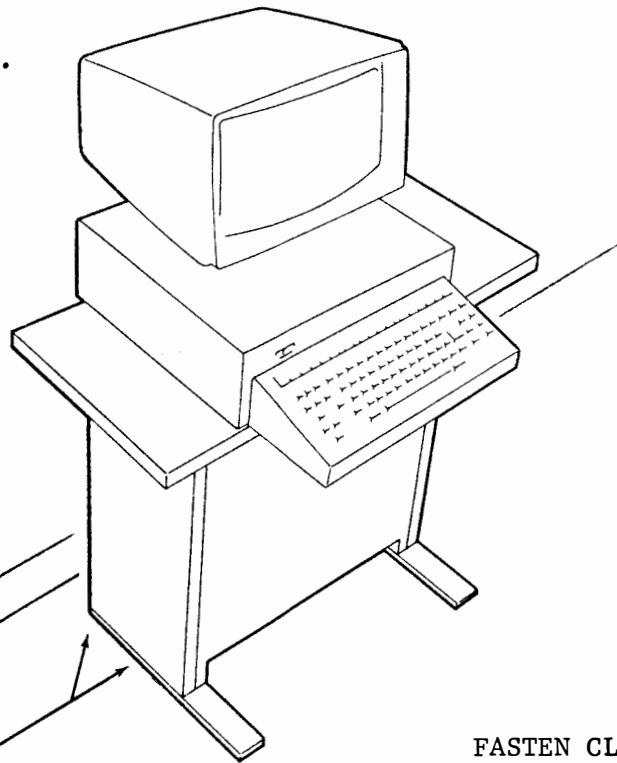

PEDESTAL LEVELING
ADJUSTING SCREWS
(Each Side - Back Only)

FASTEN CLAMP
TO RECEPTACLE

SET AC
POWER CORD

AC RECEPTACLE
SHOULD NOT BE UNDER
CONTROL OF A WALL SWITCH

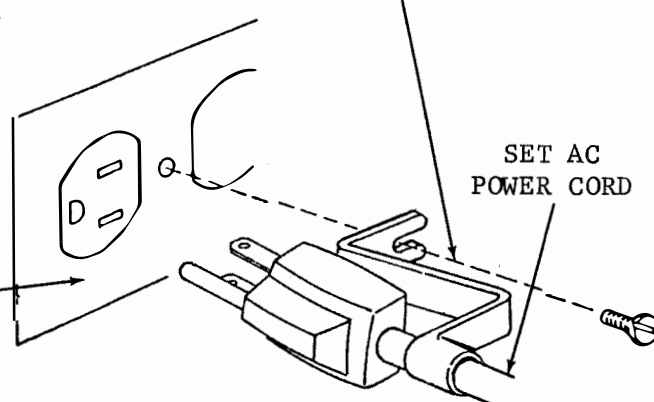

B. INSTALLATION

6. Listing of Options Feature and Modifications

FEATURES AND OPTION RECORD

Check on variable # as furnished
 * (asterisk) Indicates Factory Programming

SET & FEATURES	RELATED FIELD OPTIONS	
BASIC KSR <input type="checkbox"/> (Serial EIA)	1 (a) EIA to Printer <input type="checkbox"/> 3 (a) 1050 Baud Send/Receive <input type="checkbox"/> 3 (c) 2400 WPM future use <input type="checkbox"/> 4 (a) Rev. Chan./Sent & Received * <input type="checkbox"/> 28 (a) Disconnect after 45 seconds * <input type="checkbox"/>	1 (b) SSI to Printer * <input type="checkbox"/> 3 (b) 1200 Baud Send/Receive * <input type="checkbox"/> 4 (b) Rev. Chan./Not Sent-Received <input type="checkbox"/> 28 (b) Does not disconnect-disabled <input type="checkbox"/>
KSR (PTI) <input type="checkbox"/>	None	
PRINTER <input type="checkbox"/>	17 (a) 1st Char. — 1st Position * <input type="checkbox"/> 17 (c) Last Char. — 80th Position * <input type="checkbox"/> 17 (e) 11 Inch Form Length <input type="checkbox"/> 18 (a) No Paper Feed Out <input type="checkbox"/> 18 (c) Paper FO on RM Loss and ETX * <input type="checkbox"/> 19 (a) Symbol on Even V. P. Error * <input type="checkbox"/> 19 (c) No Symbol on V. P. Error <input type="checkbox"/> 19 (e) 64 Character Set <input type="checkbox"/> 20 (a) Single LF * <input type="checkbox"/> 21 (a) Lower and Upper Case Print (U. L.) * <input type="checkbox"/> 22 (a) Lower Case Print as Error Symbol(Mono) <input type="checkbox"/> 23 (a) Prints Extended ASCII Characters <input type="checkbox"/>	17 (b) 1st Char. — 2nd thru 12th Position <input type="checkbox"/> 17 (d) Last Char. — 73rd thru 79th Position <input type="checkbox"/> 17 (f) 2-1/2 to 22 Inch Form Length <input type="checkbox"/> 18 (b) Paper FO of 16 Lines on RM Loss <input type="checkbox"/> 19 (b) Symbol on Odd V. P. Error <input type="checkbox"/> 19 (d) 96 Character Set <input type="checkbox"/> 19 (f) Printers using Ext. ASCII Char. Set <input type="checkbox"/> 20 (b) Double LF <input type="checkbox"/> 21 (b) Lower Case Printed as Upper Case (U. L.) <input type="checkbox"/> 22 (b) Lower Case Printed as Upper Case(Mono)* <input type="checkbox"/> 23 (b) Ext. ASCII Char. not Printed (See 19 a, b, or c.) <input type="checkbox"/>
FULL EDIT (Controller) <input type="checkbox"/>	5 (a) Reject NULL * <input type="checkbox"/> 5 (c) Reject CR * <input type="checkbox"/> 5 (e) Reject DELETE * <input type="checkbox"/> 6 (a) Esc. Displayed/No Functions <input type="checkbox"/> 7 (a) Vert. Par. Err. Char. Not Displayed <input type="checkbox"/> 8 (a) End Page on FF <input type="checkbox"/> 8 (c) End Page on ETX * <input type="checkbox"/> 8 (e) End Page on EOT * <input type="checkbox"/> 8 (g) End Page on GS * <input type="checkbox"/> 9 (a) High Light Not Sent <input type="checkbox"/> 10 (a) Send CR LF <input type="checkbox"/> 10 (c) Send LF <input type="checkbox"/> 11 (a) Go Local after Send * <input type="checkbox"/> 12 (a) No Form Enter in Local <input type="checkbox"/> 13 (a) Send All (PandUnp.) as Displayed <input type="checkbox"/> 13 (c) Send Protect as SPACE <input type="checkbox"/> 13 (e) Send Protect as DELETE <input type="checkbox"/> 13 (g) Send Unp. and HT at End of Field <input type="checkbox"/> 27 (a) Home Cursor on Transmit <input type="checkbox"/>	5 (b) Accept NULL <input type="checkbox"/> 5 (d) Accept CR <input type="checkbox"/> 5 (f) Accept DELETE <input type="checkbox"/> 6 (b) Esc. Not Displayed/Function Enabled * <input type="checkbox"/> 7 (b) Vert. Par. Err. Char. Displayed * <input type="checkbox"/> 8 (b) Do Not End Page on FF * <input type="checkbox"/> 8 (d) Do Not End Page on ETX <input type="checkbox"/> 8 (f) Do Not End Page on EOT <input type="checkbox"/> 8 (h) Do Not End Page on GS <input type="checkbox"/> 9 (b) High Light Sent * <input type="checkbox"/> 10 (b) Send CR CR LF * <input type="checkbox"/> 11 (b) Go Receive after Send <input type="checkbox"/> 12 (b) Form Enter Enabled in Local * <input type="checkbox"/> 13 (b) Send All/HT Convert to SPACE * <input type="checkbox"/> 13 (d) Send Protect & HT as SPACE <input type="checkbox"/> 13 (f) Send Unprotect (Unp.) Only <input type="checkbox"/> 13 (h) Send Unp. and HT as SPACE <input type="checkbox"/> 27 (b) Send from Cursor Position * <input type="checkbox"/>
(Controller) FULL EDIT (PTI Sets With EXT. Mode) <input type="checkbox"/>	11 (c) Replaces 11 (a) or 11 (b) * <input type="checkbox"/> 14 (a) Rec. Select on * <input type="checkbox"/> 15 (a) Override goes to Rec. <input type="checkbox"/> 16 (a) Rec. after TDA * <input type="checkbox"/> 16 (c) Home after TDA <input type="checkbox"/>	14 (b) Rec. Select off <input type="checkbox"/> 15 (b) Stays in Send or Loc * <input type="checkbox"/> 16 (b) Loc after TDA <input type="checkbox"/> 16 (d) Stays at Mess. end * <input type="checkbox"/>
(Controller) CONVERSATION MODE <input type="checkbox"/>	2 (a) DC ₂ Sent Auto. * <input type="checkbox"/>	2 (b) DC ₂ Sent with Message <input type="checkbox"/>
RO SET <input type="checkbox"/>	3 (a) 1050 Baud <input type="checkbox"/> 24 (a) Even VP Detection * <input type="checkbox"/> 25 (a) Odd Parity Null Sent to Printer <input type="checkbox"/> 25 (c) D. E. Lamp Turns On <input type="checkbox"/> 26 (a) Discr Call Coded <input type="checkbox"/> 26 (c) Discr Call Sent <input type="checkbox"/>	3 (b) 1200 Baud * <input type="checkbox"/> 24 (b) Odd VP Detection <input type="checkbox"/> 25 (b) Received Character Sent to Printer * <input type="checkbox"/> 25 (d) D. E. Lamp Does Not Turn On * <input type="checkbox"/> 26 (b) Discr Call Not Coded * <input type="checkbox"/> 26 (d) Discr Call Not Sent * <input type="checkbox"/>
SET VARIATIONS	Mono-Case <input type="checkbox"/> Upper-Lower Case <input type="checkbox"/> 24 Line Display <input type="checkbox"/> 48 Line Display <input type="checkbox"/> 72 Line Display <input type="checkbox"/>	Pedestal <input type="checkbox"/> Paper Winder <input type="checkbox"/> Copy Holder <input type="checkbox"/>

IN CASE OF TROUBLE OR A NEED FOR SERVICE, CONTACT THE NEAREST TELETYPE PRODUCT SERVICE CENTER (PAGE 3)



FEATURES AND OPTION RECORD

Check on variable # as furnished
* (asterisk) Indicates Factory Programming

SET & FEATURES	RELATED FIELD OPTIONS	
BASIC KSR <input type="checkbox"/> (Serial EIA)	1 (a) EIA to Printer <input type="checkbox"/> 3 (a) 1050 Baud Send/Receive <input type="checkbox"/> 3 (c) 2400 WPM future use <input type="checkbox"/> 4 (a) Rev. Chan./Sent & Received * <input type="checkbox"/> 28 (a) Disconnect after 45 seconds * <input type="checkbox"/>	1 (b) SSI to Printer * <input type="checkbox"/> 3 (b) 1200 Baud Send/Receive * <input type="checkbox"/> 4 (b) Rev. Chan./Not Sent-Received <input type="checkbox"/> 28 (b) Does not disconnect-disabled <input type="checkbox"/>
KSR (PTI) <input type="checkbox"/>	None	
PRINTER <input type="checkbox"/>	17 (a) 1st Char. — 1st Position * <input type="checkbox"/> 17 (c) Last Char. — 80th Position * <input type="checkbox"/> 17 (e) 11 Inch Form Length <input type="checkbox"/> 18 (a) No Paper Feed Out <input type="checkbox"/> 18 (c) Paper FO on RM Loss and ETX * <input type="checkbox"/> 19 (a) Symbol on Even V. P. Error * <input type="checkbox"/> 19 (c) No Symbol on V. P. Error <input type="checkbox"/> 19 (e) 64 Character Set <input type="checkbox"/> 20 (a) Single LF * <input type="checkbox"/> 21 (a) Lower and Upper Case Print (U. L.) * <input type="checkbox"/> 22 (a) Lower Case Print as Error Symbol(Mono) <input type="checkbox"/> 23 (a) Prints Extended ASCII Characters <input type="checkbox"/>	17 (b) 1st Char. — 2nd thru 12th Position <input type="checkbox"/> 17 (d) Last Char. — 73rd thru 79th Position <input type="checkbox"/> 17 (f) 2-1/2 to 22 Inch Form Length <input type="checkbox"/> 18 (b) Paper FO of 16 Lines on RM Loss <input type="checkbox"/> 19 (b) Symbol on Odd V. P. Error <input type="checkbox"/> 19 (d) 96 Character Set <input type="checkbox"/> 19 (f) Printers using Ext. ASCII Char. Set <input type="checkbox"/> 20 (b) Double LF <input type="checkbox"/> 21 (b) Lower Case Printed as Upper Case (U. L.) <input type="checkbox"/> 22 (b) Lower Case Printed as Upper Case(Mono)* <input type="checkbox"/> 23 (b) Ext. ASCII Char. not Printed (See 19 a, b, or c.) <input type="checkbox"/>
FULL EDIT <input type="checkbox"/> (Controller)	5 (a) Reject NULL * <input type="checkbox"/> 5 (c) Reject CR * <input type="checkbox"/> 5 (e) Reject DELETE * <input type="checkbox"/> 6 (a) Esc. Displayed/No Functions <input type="checkbox"/> 7 (a) Vert. Par. Err. Char. Not Displayed <input type="checkbox"/> 8 (a) End Page on FF <input type="checkbox"/> 8 (c) End Page on ETX * <input type="checkbox"/> 8 (e) End Page on EOT * <input type="checkbox"/> 8 (g) End Page on GS * <input type="checkbox"/> 9 (a) High Light Not Sent <input type="checkbox"/> 10 (a) Send CR LF <input type="checkbox"/> 10 (c) Send LF <input type="checkbox"/> 11 (a) Go Local after Send * <input type="checkbox"/> 12 (a) No Form Enter in Local <input type="checkbox"/> 13 (a) Send All (Pand Unp.) as Displayed <input type="checkbox"/> 13 (c) Send Protect as SPACE <input type="checkbox"/> 13 (e) Send Protect as DELETE <input type="checkbox"/> 13 (g) Send Unp. and HT at End of Field <input type="checkbox"/> 27 (a) Home Cursor on Transmit <input type="checkbox"/>	5 (b) Accept NULL <input type="checkbox"/> 5 (d) Accept CR <input type="checkbox"/> 5 (f) Accept DELETE <input type="checkbox"/> 6 (b) Esc. Not Displayed/Function Enabled * <input type="checkbox"/> 7 (b) Vert. Par. Err. Char. Displayed * <input type="checkbox"/> 8 (b) Do Not End Page on FF * <input type="checkbox"/> 8 (d) Do Not End Page on ETX <input type="checkbox"/> 8 (f) Do Not End Page on EOT <input type="checkbox"/> 8 (h) Do Not End Page on GS <input type="checkbox"/> 9 (b) High Light Sent * <input type="checkbox"/> 10 (b) Send CR CR LF * <input type="checkbox"/> 11 (b) Go Receive after Send <input type="checkbox"/> 12 (b) Form Enter Enabled in Local * <input type="checkbox"/> 13 (b) Send All/HT Convert to SPACE * <input type="checkbox"/> 13 (d) Send Protect & HT as SPACE <input type="checkbox"/> 13 (f) Send Unprotect (Unp.) Only <input type="checkbox"/> 13 (h) Send Unp. and HT as SPACE <input type="checkbox"/> 27 (b) Send from Cursor Position * <input type="checkbox"/>
(Controller) FULL EDIT <input type="checkbox"/> (PTI Sets With EXT. Mode)	11 (c) Replaces 11 (a) or 11 (b) * <input type="checkbox"/> 14 (a) Rec. Select on * <input type="checkbox"/> 15 (a) Override goes to Rec. <input type="checkbox"/> 16 (a) Rec. after TDA * <input type="checkbox"/> 16 (c) Home after TDA <input type="checkbox"/>	14 (b) Rec. Select off <input type="checkbox"/> 15 (b) Stays in Send or Loc * <input type="checkbox"/> 16 (b) Loc after TDA <input type="checkbox"/> 16 (d) Stays at Mess. end * <input type="checkbox"/>
(Controller) CONVERSATION MODE <input type="checkbox"/>	2 (a) DC ₂ Sent Auto. * <input type="checkbox"/>	2 (b) DC ₂ Sent with Message <input type="checkbox"/>
RO SET <input type="checkbox"/>	3 (a) 1050 Baud <input type="checkbox"/> 24 (a) Even VP Detection * <input type="checkbox"/> 25 (a) Odd Parity Null Sent to Printer <input type="checkbox"/> 25 (c) D.E. Lamp Turns On <input type="checkbox"/> 26 (a) Discr Call Coded <input type="checkbox"/> 26 (c) Discr Call Sent <input type="checkbox"/>	3 (b) 1200 Baud * <input type="checkbox"/> 24 (b) Odd VP Detection <input type="checkbox"/> 25 (b) Received Character Sent to Printer * <input type="checkbox"/> 25 (d) D.E. Lamp Does Not Turn On * <input type="checkbox"/> 26 (b) Discr Call Not Coded * <input type="checkbox"/> 26 (d) Discr Call Not Sent * <input type="checkbox"/>
SET VARIATIONS	Mono-Case <input type="checkbox"/> Upper-Lower Case <input type="checkbox"/> 24 Line Display <input type="checkbox"/> 48 Line Display <input type="checkbox"/> 72 Line Display <input type="checkbox"/>	Pedestal <input type="checkbox"/> Paper Winder <input type="checkbox"/> Copy Holder <input type="checkbox"/>



C. OPERATIONAL CHECKOUT

C. Operational Checkout

	<u>INDEX</u>	<u>PAGE</u>
1.	General.	63
2.	Brief Checkout	64
	a. Off-Line - KSR	64
	b. On-Line - KSR.	65
3.	Complete Checkout - KSR	68
	a. Off-Line - KSR	68
	b. Local Interface - KSR.	79
	(1) TSG-803 Instructions	79
	(2) PTI Checkout	87
	c. On-Line Switched Network	92
	(1) All KSR Terminals	93
	(a) Factory Furnished Options	93
	(b) Option Exceptions	94
	(2) Conversational Mode.	95
	(a) Factory Furnished Options	95
	(b) Option Exceptions	95a
	(3) KSR Sets with Full Edit Features	95b
	(a) Factory Furnished Options	95b
	(b) Option Exceptions	96
	(4) Prepared Test Messages	97
	(5) Chart A.	99
4.	Complete Checkout RO	104
	a. Factory Furnished Options.	104
	b. Option Exceptions.	106
	c. Prepared RO Test Messages	107

C. Operational Checkout (Continued)

1. General

- All standard telephone line and data modem checks should be performed before the initial on-line checkout of the Model 40 terminal. When trouble analysis indicates a problem in the modem line or data set, refer to the appropriate equipment support literature for the trouble analysis.
- The brief checkout should be performed after the initial installation, to facilitate checking of the display alignment adjustments, and to determine that the major components are operational before proceeding with the complete checkout. If a complete checkout is performed just prior to installation on the customer's premises, the installation checkout can be limited to the brief checkout.
- The complete checkout should be performed after the brief installation checkout to assure a complete check of all features and options. On subsequent maintenance or trouble calls, the checkout can be limited to the specific trouble reported or to the brief checkout, to facilitate the isolation of a poorly defined trouble area. If the troubles were extensive, it may be desirable to perform the complete checkout following component substitutions.
- Before performing checkout procedures make sure that the terminal is connected to a properly grounded ac power source, all cards and cable connectors are fully seated, the lids are closed, the paper is installed etc. The power switches should be turned on or off under the direction of the checkout or other procedures. They are located at the rear of each module and at the front under the top of the pedestal (if present). To turn the power on, all the switches must be turned on. To turn the power off, all the switches must be turned off, with the exception of the Monitor power switch. The checkout should always be performed in the sequence given, since the trouble number listed with each checkout step is based on prior requirements being met.
- In the checkout procedures in this section, for identification of displayed characters, the following symbols are used.

For protected character(s);

U

U*U*U*

For highlighted character(s)

*U

U*U*U*

C. Operational Checkout (Continued)

2. Brief Checkout

KSR and KSR with printer

Trouble
Analysis
References

a. Off-Line - KSR

1. Turn on all power to the terminal. For the location of the switches refer to general information of this section.

- The LOCAL key should light (Figure 1).
- The fans should operate (check by feeling air movement at rear of logic module cabinet or under the pedestal).

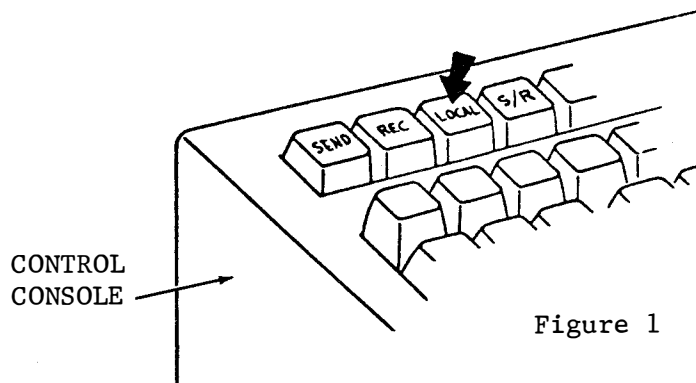

Figure 1

2. Turn on the power to the monitor (Figure 2). Turn the brightness control to maximum brightness (Figure 2).

Page 161

- Within 10 seconds the raster should be barely visible with the cursor at the top displaced approximately 1/2 inch from the left (home position). See Figure 3. If characters appear on monitor or if the cursor is not in home position, this is usually caused by power variations when the entire set is first turned on. In this instance depress HOME then CLEAR keys to home the cursor and clear the display.
- The no. 1 segment marker (-) should be displayed to the left of home position (Figure 3).
- The raster should be aligned horizontally and vertically to the respective lines of the cabinet (Figure 3).

Page 164

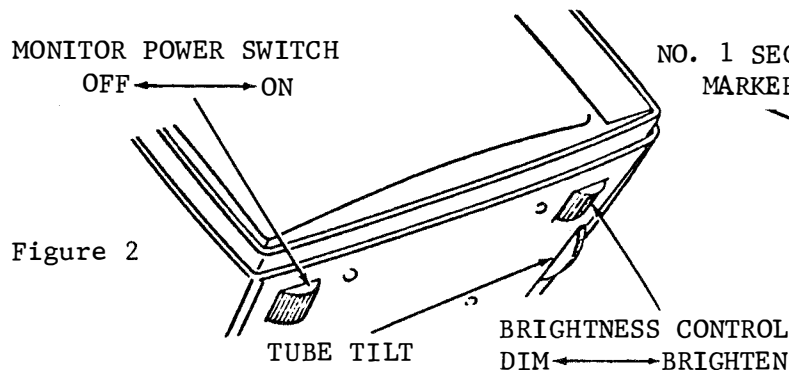

Figure 2

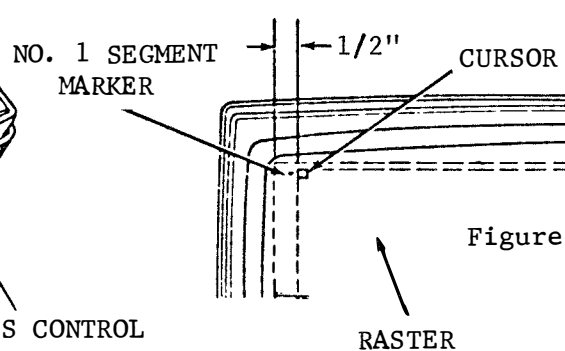

Figure 3

C. Operational Checkout (Continued)

2. Brief Checkout (Continued)

a. Off-Line - KSR (Continued)

3. Operate the keyboard to display a series of E's on the top and bottom lines of the display area (Figure 4). Adjust brightness and tube tilt to personal preference.

- The display (80 columns by 24 lines) should measure approximately 11-1/4 inches wide by 5-1/4 inches high (1/2 character accuracy).
- The display should be centered on the tube face. Gauge by eye.
- The display characters should be well defined.
- The width of the character E should be uniform throughout the line as gauged by eye.
- The height of the character E at the top of the column should be equal to that at the bottom as gauged by eye.
- The segment marker should be completely in view.

Trouble
Analysis
References

Pages 162
& 163

Page 164

Page 161

Page 163

Page 162

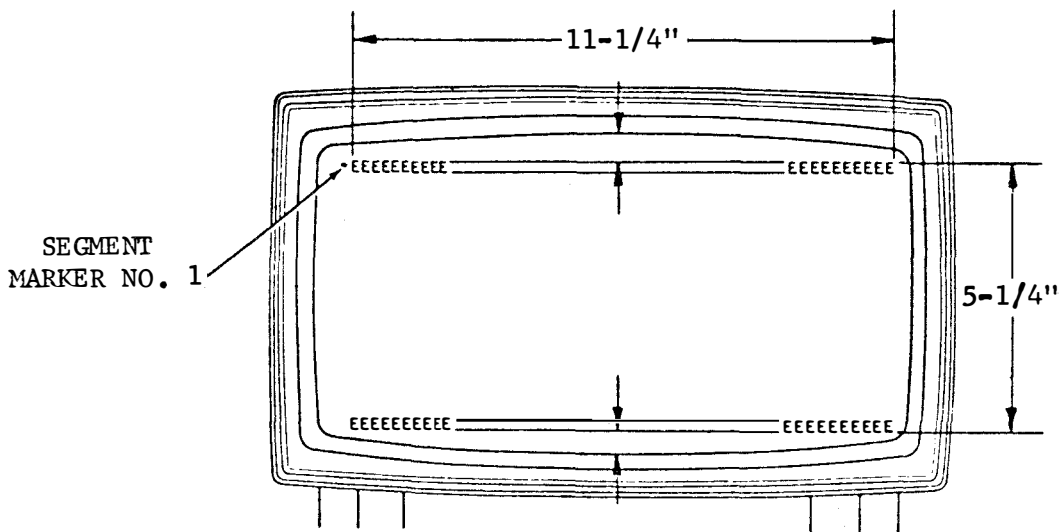

Figure 4

b. On-Line - KSR (for Switched Network applications only)

1. Starting with a clear screen (home, then clear) display a NEW LINE (\equiv) then a "Quick Brown Fox" or similar test message followed by ETX.

C. Operational Checkout (Continued)

2. Brief Checkout (Continued)

b. On-Line - KSR (Continued)

Trouble
Analysis
References

Perform the on-line test as follows:

2. Select PRINT ON LINE (if present).

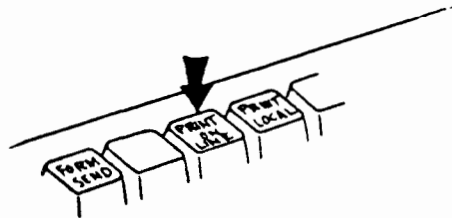

3. Home cursor

4. Call another Model 40 terminal being used in a Switched Network application. This terminal will now be acting as the test facility.

5. Select Send Mode.

6. Go into Data mode after the high-pitched tone is heard and hang up.

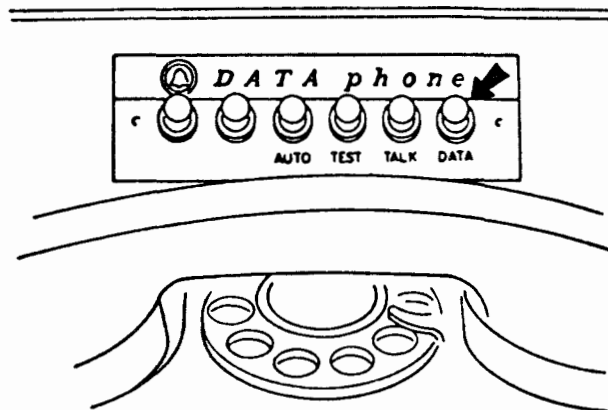

C. Operational Checkout (Continued)

2. Brief Checkout (Continued)

b. On-Line - KSR (Continued)

Trouble
Analysis
References

- Message is sent as the cursor moves through the characters.
 - Printer should copy (if present).
 - Terminal should revert to Local mode (unless 8.d. is present). See Page 96.
 - Full edit terminal will go to Receive mode (if option no. 8.c. and 11.b. are present).
7. Select Receive mode (if not already in Receive).
- Message from the test terminal (same as sent) should be displayed on the monitor.
 - Printer should copy (if present).
 - Terminal should revert to Local mode.

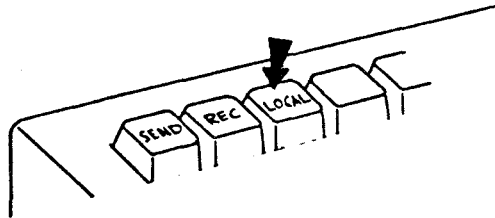

8. Go into Talk mode and inform attendant at test terminal that testing is concluded, or further testing is required.

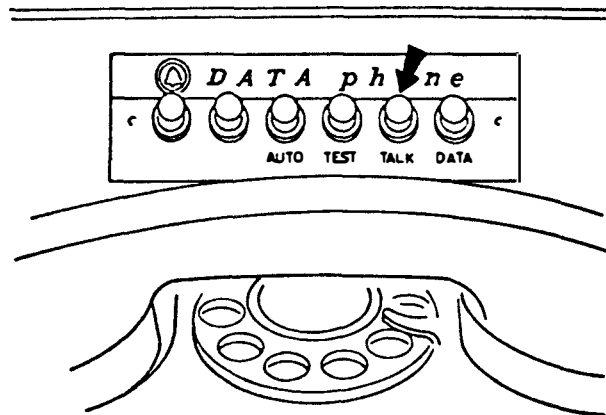

END OF BRIEF CHECKOUT

C. Operational Checkout (Continued)

3. Complete Checkout - KSR

a. Off-Line - KSR

Trouble
Analysis
References

The following tests apply to both the KSR and the KSR w/printer sets unless otherwise stated:

1. With all power off, turn the power to the set and monitor on. Adjust monitor brightness control to desired level. See Figure 2 for the location of this control. Engage the "CAPS LOCK" key on the keyboard if provided.

- The Local Lamp on the OPCON lights.
- The cursor appears in the upper left-hand corner of the display (the home position).
- The segment 1 marker appears to the left of the cursor.

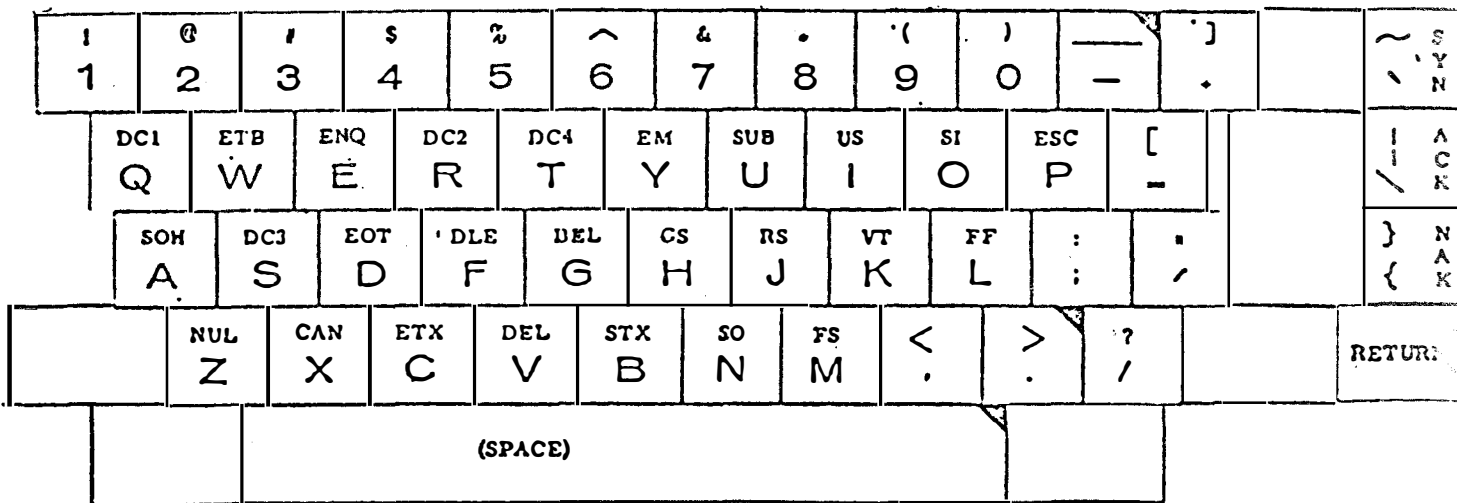

Figure 5

2. Depress each key on the keyboard portion of the OPCON indicated in Figure 5.

- The characters on the lower portion of the depressed keys are displayed. The RETURN key is displayed as "←".

NOTE: When a blocking key is provided, over the caps lock position, the set is coded for upper case alpha characters only. If during this checkout lower case alpha characters are generated, remove the blocking cap, operate the switch, and replace the blocking cap. Recheck.

- The ALPHAs are displayed in upper case.

C. Operational Checkout (Continued)

3. Complete Checkout - KSR (Continued)

a. Off-Line - KSR (Continued)

Trouble
Analysis
References

3. Depress the

NEW LINE

 key.

- The new line character "≡" is displayed.
- The cursor moves to the beginning of the next line.

For sets with the up-low feature, perform the following step:

3a. Disengage the "CAPS LOCK" key by depressing it again momentarily. Again depress each key on the keyboard shown in Figure 5. Then depress the "NEW LINE" key.

- The same characters described in Step 2 are displayed with the exception of the alphas, which are displayed in lower case.
- The cursor then moves to the beginning of the next line.

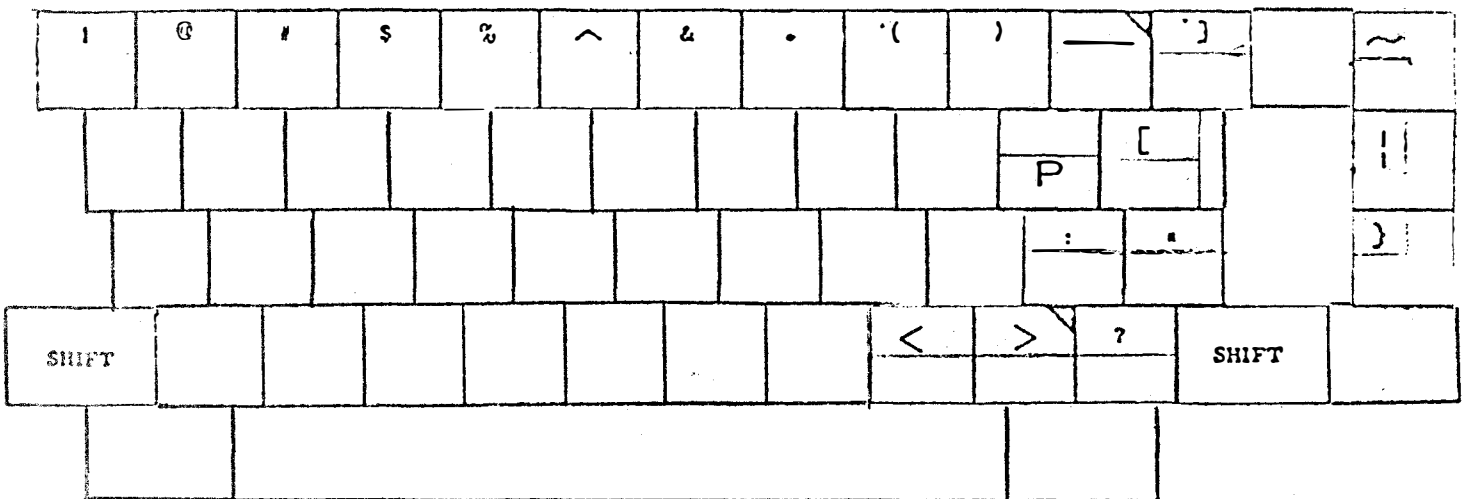

Figure 6.

4. Depress the left

SHIFT

 key together with the keys indicated in

Figure 6.

- The characters indicated in Figure 6 are displayed. The letter "P" is displayed in upper case.

5. Depress the Right

SHIFT

 key and one of the non-alpha keys

shown in Figure 6. Then depress "NEW LINE".

- The corresponding character indicated in Figure 6 is displayed.
- The cursor moves to the beginning of the next line after "≡" is displayed.

C. Operational Checkout (Continued)

3. Complete Checkout - KSR (Continued)

a. Off-Line - KSR (Continued)

Trouble
Analysis
References

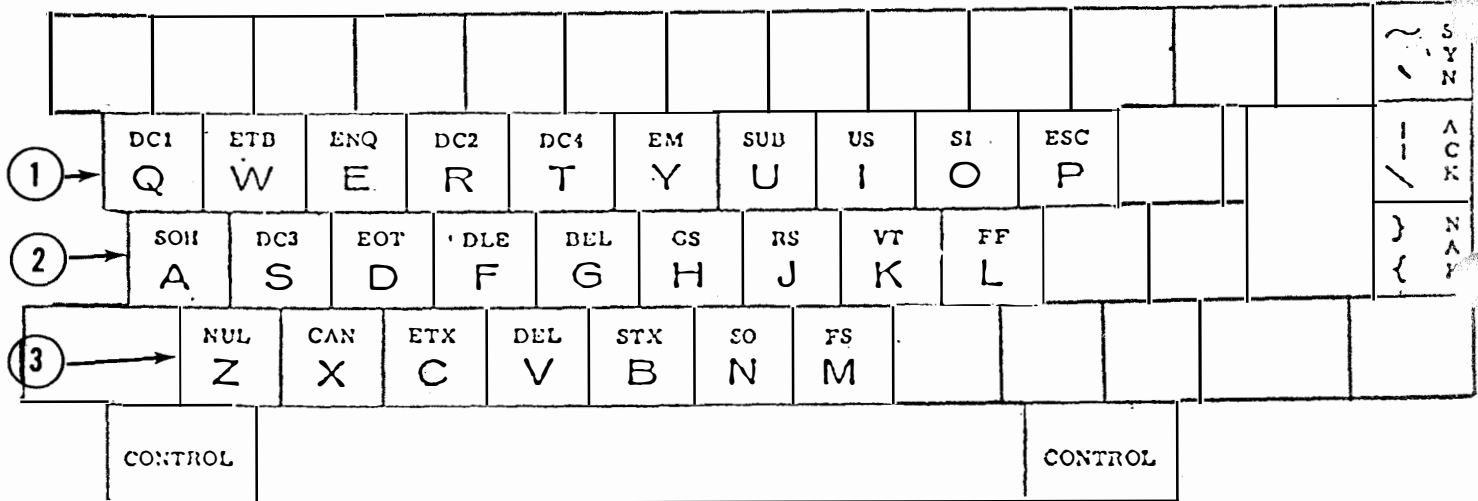

Figure 7

6. Depress the left CONTROL key together with the keys

containing control characters (see Figure 7) in the order shown below.

- The control characters appear on the display monitor in the following order:

<u>KEYTOP DESIG.</u>	<u>DISPL YED CH RS.</u>	<u>KEYTOP DESIG.</u>	<u>DISPL YED CHARS.</u>
① DC1	D ₁	ESC	E _C
ETB	E _B	② SOH	S _H
ENQ	E _Q	DC3	D ₃
DC2	D ₂	EOT	E _T
DC4	D ₄	DLE	D _L
EM	E _M	BEL	B _L
SUB	S _B	GS	G _S
US	U _S	RS	R _S
SI	S _I	VT	V _T

C. Operational Checkout (Continued)

3. Complete Checkout - KSR (Continued)

a. Off-Line - KSR (Continued)

Trouble
Analysis
References

<u>KEYTOP DESIG.</u>	<u>DISPLAYED CHARS.</u>	<u>KEYTOP DESIG.</u>	<u>DISPLAYED CHARS.</u>
FF	F _F	SO	S _O
③ NUL	N _U	FS	F _S
CAN	C _N	④ SYN	S _Y
ETX	E _X	ACK	A _K
DEL	//	NAK	N _K
STX	S _X		

7. Depress the right CONTROL key with one of the keys depressed in the previous step. Then depress "NEW LINE."
- The corresponding control character is displayed.
 - The cursor moves to the beginning of the next line.

8. Depress the following keys fully for a short amount of time:

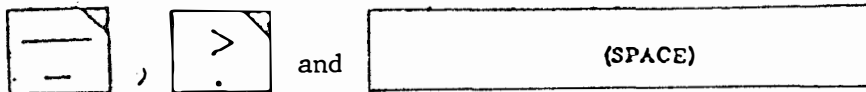

- The dashes, periods and spaces are repeatedly written on the display. (Note: There is a momentary delay after fully depressing the repeating keys before the function occurs.)

9. Depress the CURSR
RETRN key. Then depress once each of the following cursor movement keys located on the left side of the OPCON. Depress in the order shown:

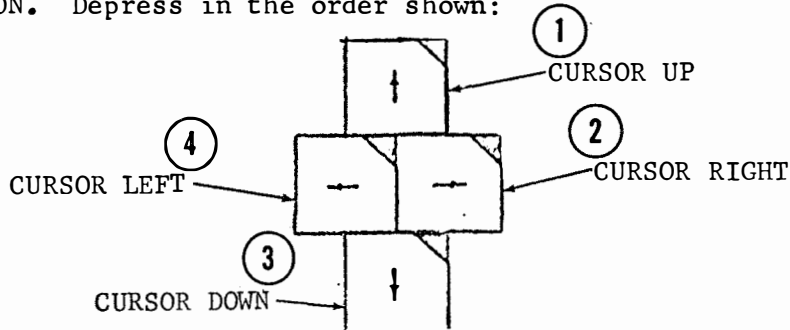

- The cursor moves to the beginning of the same line.
- The cursor moves one character position in the directions indicated by the arrows.

C. Operational Checkout (Continued)

3. Complete Checkout - KSR (Continued)

a. Off-Line - KSR (Continued)

Trouble
Analysis
References

10. Depress the  key. Next, fully depress in order, the cursor down, cursor right, cursor up and cursor left keys, releasing each key only after the cursor has stopped moving.
- The cursor moves to the home position. It then traces the outer extremities of the display, stopping at each corner; finally returning to the home position.

11. Place the cursor over the "E_M" control character on the display. Depress the  key momentarily; then depress it fully - releasing it after the characters stop moving.
- The "E_M" character and every character to the right of the cursor first move one position to the right and a space is written under the cursor. This is then done repeatedly; each time the characters, including all spaces, are moved one position to the right until the last displayed character on the line occupies the last (the 80th) character position.

12. Depress the  momentarily; then depress it fully.
- Every character to the right of the cursor moves one position to the left. The character formerly under the cursor is deleted and a space is written in the last character position of line. This is then done repeatedly until spaces are written in every position from the cursor to the end of the line.

The following step should be performed for a KSR w/printer.

- 12a. Home the cursor, then depress the  key.
- The cursor returns to the HOME position.
 - The "PRINT LOCAL" lamp lights.
 - The cursor moves over each character as it is transmitted. On lines with no "NEW LINE" character, the cursor moves to the next line after transmitting the 80th character of a line.

C. Operational Checkout (Continued)

3. Complete Checkout - KSR (Continued)

a. Off-Line - KSR (Continued)

Trouble
Analysis
References

- The printer begins copying the message exactly as displayed with the following exceptions:
 1. The "NEW LINE" character will not be printed.
 2. The printer may be programmed for single or double line feed. (optional)
 3. Control characters will not be printed.
 4. Five characters, opening brace ({), closing brace (}), grave accent (`), vertical line (|), and tilde (~) are dependent on the features and options of the printer as follows:

- (a) On up-low printers they will be printed exactly as displayed.
- (b) On monospace printers without foldover (option 22) the errored character symbol will be printed for each of those characters.
- (c) On monospace printers with foldover those characters will be substituted as follows:

@ for `
[for {
\ for |
] for }
^ for ~

- The cursor will continue across the page until it reaches the last character position in the last line. At this time the cursor stops, an ETX is automatically transmitted and the printer feeds out 16 lines of paper. (optional) 18c.
- The "PRINT LOCAL" lamp then goes out.

13. Home the cursor and depress the CLEAR key.

- The screen is cleared of all characters.

The following tests should be performed only on the sets with the options or features indicated at the beginning of each group of steps.

DISPLAY PAGE CONTAINING 1 SEGMENT WITHOUT FULL EDIT

14. Type a line of 80 "*"s across the top of the page. Depress

the LINE
INSRT key and type a row of "U"s.

C. Operational Checkout (Continued)

3. Complete Checkout - KSR (Continued)

a. Off-Line - KSR (Continued)

Trouble
Analysis
References

- A line of "*"s is written, the cursor moves to the beginning of the line, and the "*"s are moved to the second line. A line of "U"s is then written on the first line.

15. Repeatedly depress the "LINE INSERT" key until the line of asterisks is moved to the last line of the page.

- The line is moved down unchanged.

16. Move the cursor down to the last line of the page and depress

the

LINE DELETE

 key.

- The line of asterisks are removed.

17. Move the cursor to the line of "U's" and depress the line insert key.

- The line of "U's" moves to the bottom of the page unchanged. (Go to Step 29 on Full Edit Multiple segment terminals.)

DISPLAY PAGE CONTAINING 2 OR 3 SEGMENTS (WITHOUT FULL EDIT)

18. Depress the

SEGMT ADV

 key twice. (3 times if 3 segments are present).

- The segment marker in the top left hand corner of the display changes from the segment one marker (-), to the segment two marker (=), to the segment three marker (≡) on sets with 3 segments, back to the segment one marker. The position of the cursor does not change.

19. Depress the

SCROL UP

 key once.

- The segment one marker disappears from the top left of the display as the segment two marker appears in the bottom left of the display. The position of the cursor on the display does not change.

20. Fully depress the "SCROL UP" key.

- The segment two marker (then three if 3 segments are present) moves up the display, stopping in the top left hand corner. The position of the cursor on the display does not change.

C. Operational Checkout (Continued)

3. Complete Checkout - KSR (Continued)

a. Off-Line - KSR (Continued)

Trouble
Analysis
References

21. Depress the

SCROL DOWN

 key once, then press it fully.

- The segment marker in the upper left hand corner of the page moves down one line. It then continues down the page and disappears after it reaches the bottom of the display. At this time, the marker for the previous segment appears in the upper left hand corner and (if it is the segment two marker) also continues down the display. When the segment one marker appears in the upper left corner, all movement ceases.
Go to Step 45 on full edit sets.

22. Do steps 14, 15, 16, 17 depressing "SCROL UP" whenever necessary to keep both lines in view.

- Same results as in the above mentioned steps with the addition of the scrolling action (Step 19).

DISPLAY PAGE CONTAINING 1 SEGMENT WITH FULL EDIT

23. Alternately depress the

TAB SET

 key and the space bar on the

operator's console until the cursor reaches the end of the line. Alarm will sound at 73rd & 80th positions.

- A tab mark is written in every position on the page.
Note: On pages containing more than one segment, it will be necessary to depress the "SEGMT ADV" or "SCROL UP" keys to view the remainder of the page.

24. Depress the "HOME" key. Then depress the

TAD CLEAR

 key.

- All tab marks on the page are erased.

25. Clear the screen. Depress the

HIGH LIGHT

 key. Type in a line of 80 "*"s." Depress the highlight key again, then depress the

LINE INSRT

 key.

- The screen is cleared. The highlight lamp lights.
- The alarm sounds at the 73rd and last character positions of the line as the "*"s" are written.
- The line of "*"s" are highlighted.
- The highlight lamp goes out.
- The cursor moves to the beginning of the same line, and the line of "*"s" is moved down one line.

C. Operational Checkout (Continued)

3. Complete Checkout - KSR (Continued)

a. Off-Line - KSR (Continued)

Trouble
Analysis
References

26. Depress the

FORM ENTER

 key. (If option 12.a is present,
change temporarily to 12.b.) Type in a full line of
"U's."

- The "FORM ENTER" key lights.
- A line of "U's" are displayed at half intensity.
- The cursor is at the end of the first line.

27. Depress the

LINE INSRT

 key once.

- The cursor moves to the beginning of the line.
- The two lines are moved down 1 line position and the line on which the cursor is found is overwritten with spaces.

28. Repeat steps 15, 16 and 17.

- Results are the same as in the above mentioned steps.

29. Home the cursor, clear the screen and depress the "FORM ENTER" key.

- The cursor goes home, the screen is cleared and the "FORM ENTER" lamp goes out.

30. Place the following message on the display:

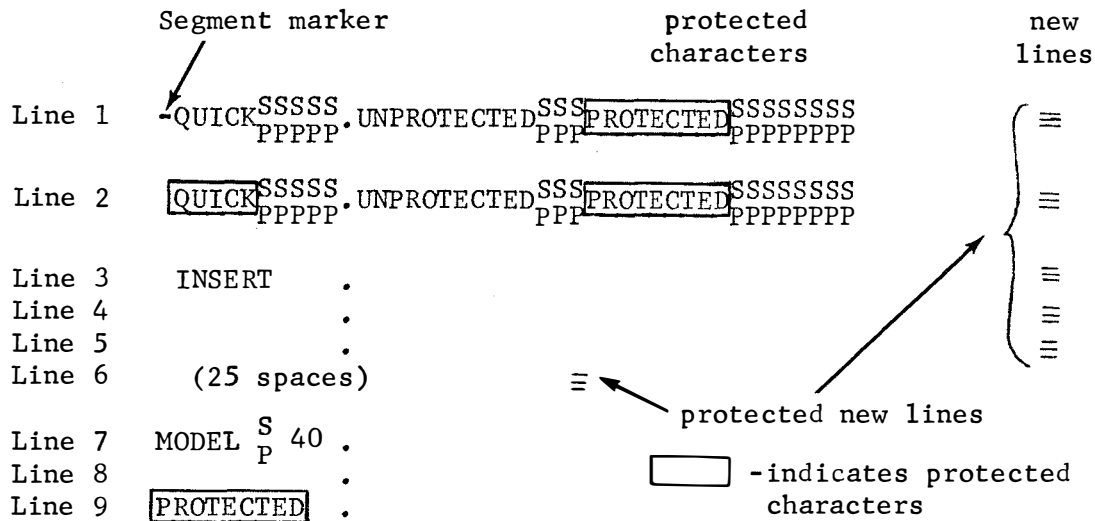

31. Extinguish the "FORM ENTER" lamp if still lit. Home the cursor. Depress and hold the "CHAR INSRT" key until all movement stops.

- Spaces are inserted moving the first "QUICK" up to the tab mark. No other characters on the display are affected.

C. Operational Checkout (Continued)

3. Complete Checkout - KSR (Continued)

a. Off-Line - KSR (Continued)

Trouble
Analysis
References

32. Depress the "CHAR DLETE" key twice.
- The work "QUICK" is moved two positions to the left with spaces being written between the end of the word and the first tab mark. No other characters on the display are affected.
33. Depress the

TAB

 key once.
- The HT ► is written and the cursor moves to the first tab mark and every character passed over by the cursor is erased.
34. Depress the "CHAR INSRT" key fully.
- The word "UNPROTECTED" moves three spaces to the right. No other characters are affected.
35. Depress the "CHAR DLETE" key fully.
- The word "UNPROTECTED" is moved to the left and completely erased. No other characters are affected.
36. Depress the "TAB KEY" again. Depress the space bar once, and then depress it fully.
- The cursor moves to the first character position after the word "PROTECTED."
 - The bell sounds once the first time that the space bar is depressed, and repeatedly sounds when the cursor is in the character position immediately preceding the protected line feed. The cursor does not move beyond this position.
37. Depress the "TAB" key again.
- The cursor moves to the end of the protected word "QUICK" in the second line.
38. Depress the

CURSR
TAB

 key three times.
- The cursor moves first to the tab mark, then to the space immediately following the word "PROTECTED," and finally to the beginning of the word "INSERT." None of the characters are erased or changed in any way.
39. Depress "LINE INSERT" three times.
- The word "INSERT" moves down two lines and stops. The remainder of the display does not change.

C. Operational Checkout (Continued)

3. Complete Checkout - KSR (Continued)

a. Off-Line - KSR (Continued)

Trouble
Analysis
References

40. Move the cursor over the first letter in the beginning of the 7th line. Depress the "LINE INSRT" key twice.
- The words "MODEL 40" move down one line and stops.
41. Move the cursor over the "P" in the beginning of line 9, and type some miscellaneous characters.
- The alarm sounds each time a key is depressed and the cursor is over a protected character. No characters are able to overwrite the word "PROTECTED."
42. Home the cursor. Depress the "CLEAR" and the "TAB CLEAR" keys.
- Only the protected characters remain on the screen.
43. Depress the "FORM ENTER" key, followed by the "CLEAR" key, finally depressing the "FORM ENTER" key again.
- The "FORM ENTER" lamp lights.
 - The screen is cleared of all remaining characters.
 - The "FORM ENTER" lamp goes out.
- 43a. If originally present in Step 29, put back option 12.a. then depress FORM ENTER.
- The FORM ENTER lamp will not light.

DISPLAY PAGE CONTAINING 2 OR 3 SEGMENTS WITH FULL EDIT

44. Do steps 18, 19, 20 and 21.
- Same results as in the above mentioned steps.
45. Do steps 23-28, depressing "SCROL UP" whenever necessary to keep both lines in view.
- Same results as in the above mentioned steps with the addition of the scrolling action (Step 19).
46. Do steps 29-43.
- Same results as in the above mentioned steps.

- C. Operational Checkout (Continued)
- 3. Complete Checkout - KSR (Continued)
 - b. Local Interface - KSR

(1) TSG-803 Instructions

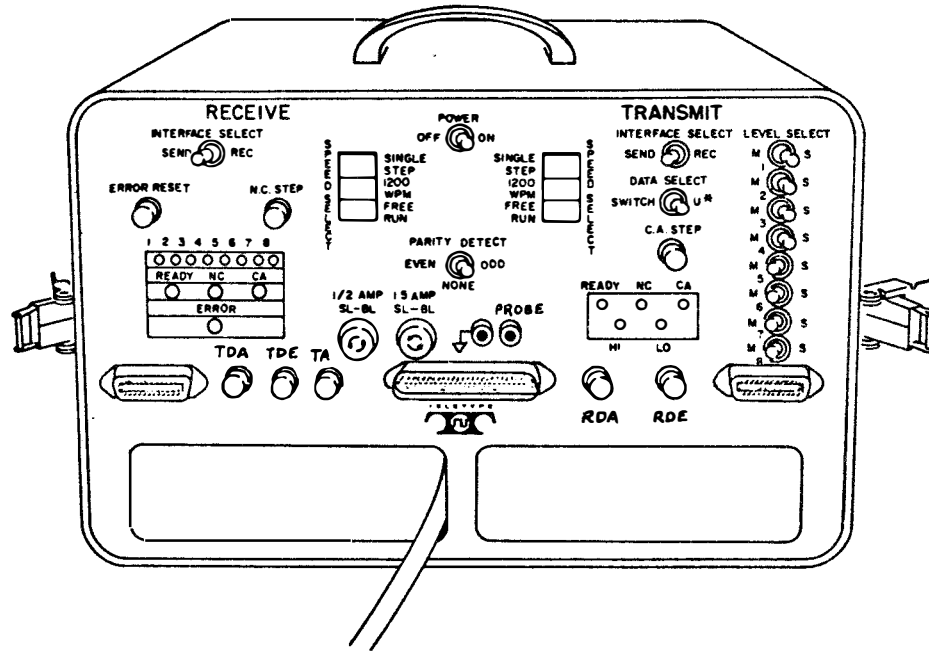

The TSG-803 is used in the checkout and troubleshooting of equipment using the Parallel Terminal Interface (PTI) signaling procedure. The Simulator is self testing in so far as its Transmit output can be looped back to it's Receive input. All Receive and Transmit capabilities may then be tested without the use of any external devices.

PROCEDURE A:

Self Test Procedure - Remove the supplied TP337683 cable assembly from the storage compartment. Connect one end of the cable to Receive connector of the TSG-803, the other end to the Transmit connector.

Plug into Power Source 117 volts.

Throw Power toggle switch to ON position. Set the remaining switches as indicated.

For a complete self-test, repeat the following procedure twice making the indicated changes for the 1st test and 2nd test.

- C. Operational Checkout (Continued)
- 3. Complete Checkout - KSR (Continued)
 - b. Local Interface - KSR (Continued)

(1) TSG-803 Instructions (Continued)

SELF TEST 1 & 2

RECEIVE SIDE (TSG-803)

TRANSMIT SIDE (TSG-803)

Interface Select

Interface Select

RECEIVE (1st Test)
SEND (2nd Test)

RECEIVE (1st Test)
SEND (2nd Test)

Speed Select

Speed Select

SINGLE STEP

SINGLE STEP

Parity Detect

Data Select

ODD (1st Test)
EVEN (2nd Test)

SWITCH

Ready lamp should be lit

Ready lamp should be lit

To perform single step test, follow procedure below:

RECEIVE (TSG-803)

TRANSMIT (TSG-803)

1. Depress NC on - lamp lights → NC - lamp lights

Level Select

2. Set switches 1M, 2S, 3M, 4S,
5M, 6S, 7M, 8S (8M 2nd Test)

- CA on - lamp lights ← 3. Depress CA on - lamp lights

Character bit lamps on should
correspond to Level Select
switches

4. Depress NC off - lamp extinguishes → NC off - lamp extinguishes
(on 2nd test, error lamp lights)
CA off - lamp extinguishes ← 5. Depress CA off - lamp extinguishes

6. Depress NC on - lamp lights → NC on - lamp lights

Level Select

7. Set switches 1S, 2M, 3S, 4M, 5S,
6M, 7S, 8M (8S 2nd Test)

- CA on - lamp lights ← 8. Depress CA on - lamp lights

- C. Operational Checkout (Continued)
- 3. Complete Checkout - KSR (Continued)
 - b. Local Interface - KSR (Continued)

(1) TSG-803 Instructions (Continued)

RECEIVE (TSG-803)

TRANSMIT (TSG-803)

Character bit lamps should correspond to Level Select switches

- 9. Depress NC off - lamp extinguishes → NC off - lamp extinguishes
 CA off - lamp extinguishes ← 10. Depress CA off - lamp extinguishes
 (on 2nd test, parity lamp lights)
- 11. Depress NC on - lamp lights NC on - lamp lights
Note: Alternate NC-on, CA-on, NC-off, CA-off.
 etc etc

To perform message test, follow procedure below:

RECEIVE (TSG-803)

TRANSMIT (TSG-803)

Data Select

U*

Speed Select

Speed Select

Step thru manually
 1200 wpm
 Free Running

Step thru manually
 1200 wpm
 Free Running

Character bit lamps should ← read character bits, CR & LF after every 76 characters (36 optionally). NC and CA lamps should light alternately, then at same time.

(PARITY ERROR Lamp should light on 2nd test)

Return to ODD Parity and depress ERROR Reset to enable transmission. NC and CA lamps should light alternately, then at same time.

Repeat for 2nd test in SEND and parity EVEN.
 Turn power off, unplug 337683 cable.

PROCEDURE B: TEST SET SENDING TO A PTI SET

To use the TSG-803 when Sending to a PTI Set put the Set in the Receive mode.

Connect customer supplied D50AB61 cable or equivalent to TSG-803 (50 pin) from PTI Set. (See Sec. A.4.)

- C. Operational Checkout (Continued)
- 3. Complete Checkout - KSR (Continued)
 - b. Local Interface - KSR (Continued)

(1) TSG-803 Instructions (Continued)

Set switches on TSG-803 as follows:

Turn Power On PTI Set

Turn Power On

TRANSMIT (TSG-803)

Interface Select

If receive device
puts up REC Sel
(otherwise put in
SEND).

RECEIVE

Speed Select

SINGLE STEP

Data Select

SWITCH

Ready lamp lights

- To perform single step tests, follow procedure below:

RECEIVE

TRANSMIT (TSG-803)

(PTI SET UNDER TEST)

Ready lamp lights

NC signal → NC - lamp lights

Level Select

1. Set switches for desired character

Character is received ← 2. Depress CA on - lamp lights

Set Under Test → NC off - lamp extinguishes

Set Under Test ← 3. Depress CA off - lamp extinguishes

Set Under Test → NC on - lamp lights

Continue depressing CA step 2 times for each character.

- C. Operational Checkout (Continued)
- 3. Complete Checkout (Continued)
 - b. Local Interface - KSR (Continued)

(1) TSG-803 Instructions (Continued)

To perform message test, follow procedure below:

RECEIVE (PTI SET UNDER TEST)	TRANSMIT (TSG-803) <u>Data Select</u> U* <u>Speed Select</u>
---------------------------------	---

Alternate U * characters should be ← 1200 WPM or FREE RUN received
 CR & LF appears after every 76 characters (optionally on 36) NC and CA lamps should light

PROCEDURE C: TEST SET RECEIVING FROM A PTI SET

To use the TSG-803 when Receiving from PTI Set. (Connected as for Procedure B)

Prepare a test message on the PTI Set. Set switches on TSG-803 as follows:

SEND <u>Interface Select</u> RECEIVE <u>Speed Select</u> SINGLE STEP <u>PARITY DETECT</u>	If send device puts up SEND Sel (otherwise put in RECEIVE). <u>Data Select</u> SWITCH
--	---

ODD for even parity reception
 EVEN for odd parity reception

To perform single step test, follow procedure below:

RECEIVE (TSG-803)	TRANSMIT (PTI SET UNDER TEST)
-------------------	----------------------------------

Ready lamp turns on ← 1. Depress SEND key

2. Depress NC on - lamp lights → Set Under Test

CA - on lamp lights ← Send 1st character & CA signal

- C. Operational Checkout (Continued)
- 3. Complete Checkout (Continued)
 - b. Local Interface - KSR (Continued)

(1) TSG-803 Instructions (Continued)

Character bit lamps on
should correspond to character sent

3. Depress NC off - lamp extinguishes → Set Under Test

CA off - lamp extinguishes ← CA signal off

4. Depress NC on - lamp lights → Set Under Test

CA on - lamp lights ← Sends 2nd character

Character bit lamps on
should correspond to character
sent etc.

Note: Depress NC twice for each character received.

- To perform message test, follow procedure below:

RECEIVE (TSG-803)

Speed Select on TSG-803

1200 WPM or Free Run

Note: If Speed Select is changed during message reception, it may be necessary to restart by depressing ERROR RESET button.

Character bit lamps should read character bits transmitted from Set under test. All will light on miscellaneous text.

NC and CA lamps should light during reception.

- C. Operational Checkout (Continued)
- 3. Complete Checkout (Continued)
 - b. Local Interface - KSR (Continued)

(1) TSG-803 Instructions (Continued)

USA STANDARD PERFORATED TAPE CODE FOR INFORMATION INTERCHANGE

	NULL	SOH	STX	ETX	EOT	ENQ	ACK	BELL	BS	HT	LF	VT	FF	CR	SO	SI	DLE	DC1	DC2	DC3	DC4	NAK	SYN	ETB	CAN	EM	SUB	ESC	FS	GS	RS	US	
1		●		●		●		●		●		●		●		●		●		●		●		●		●		●		●		●	
2			●	●			●	●			●	●			●	●			●	●			●	●			●	●			●		
3					●	●	●	●					●	●	●	●					●	●	●	●				●	●	●	●		
4									○	○	○	○	○	○	○	○	○	○	○	○	○	○	○	○	○	○	○	○	○	○	○	○	
5									○	○	○	○	○	○	○	○	○	○	○	○	○	○	○	○	○	○	○	○	○	○	○	○	
6																																	
7																																	
8																																	

SP	!	"	#	\$	%	&	'	()	*	+	,	-	.	/	0	1	2	3	4	5	6	7	8	9	:	;	<	=	>	?
@	A	B	C	D	E	F	G	H	I	J	K	L	M	N	O	P	Q	R	S	T	U	V	W	X	Y	Z	[\]	^	_
~	a	b	c	d	e	f	g	h	i	j	k	l	m	n	o	p	q	r	s	t	u	v	w	x	y	z	{		}	~	DEL

CONTROL FUNCTIONS
NON TYPING

NON TYPING

● Mark: To obtain even parity, the characters and functions shown with shaded backgrounds have 8th bit marking.
 When receiving code combinations for ~ through _ , monospace equipment such as Models 33 and 35 print respective characters @ through ^.

- C. Operational Checkout (Continued)
- 3. Complete Checkout (Continued)
 - b. Local Interface - KSR (Continued)

(2) (PTI) CHECKOUT

Trouble
Analysis
References

This checkout covers the Model 40 KSR (PTI interface with Full Edit features with or without External mode controls. Before proceeding with a complete checkout of the PTI-type set, perform the complete checkout Off-Line P68, and review all option exceptions on Page 62a. TSG-803 Test Set may be self-tested - PROCEDURE A (P79)

(a) RECEIVE OPERATION

(PTI) Set receiving from the TSG-803 Test Set
(all options as factory programmed see (d) P89 & 90A for exceptions)

1. Connect the TSG-803 Test Set to the (PTI) Set by using a customer supplied cable assembly. (See Sec. A4.)
2. Turn Power On - Test Set and (PTI) Set
Adjust brightness on the (PTI) Set

When testing the (PTI) Set as a receiver, refer to PROCEDURE B(P81). PTI Set puts up receive selectable in REC mode unless option 14b is present (P.90A).

3. With (PTI) Set in REC mode use TSG-803 Test Set, to send repeat U* in single step then across one line at 1200 and fill the page in FREE RUN.
 - Test Set READY Lamp turns on.
 - Message should appear correct on display.
4. With the (PTI) Set in the REC mode send the following characters from the TSG-803 in SINGLE STEP (CA-on, CA-off etc).
 - PTI Sets without external mode.

Mode	Character Received at PTI Set	Marking (M) Codes Sent From TSG
LOC*	FF	34
LOC*	ETX	12
LOC*	GS	1345
LOC*	EOT	38

*Return to REC mode after each return to LOC mode.

- C. Operational Checkout (Continued)
 3. Complete Checkout (Continued)
 b. Local Interface - KSR (Continued)
 (2) PTI Checkout (Continued)
 (a) Receive Operation (Continued)
 ● All PTI Sets

Displayed	Character Sent	Marking (M) Codes Sent From TSG
1 Rejected 2 Rejected 3 Rejected	Unless options 5b. d. or f. are present	Null CR DELETE None (M) 1348 (M) All (M)
4 Sb	except if option 7.a. is present	* 246
5 (H.L. lamp on) Highlighted U (H.L. lamp off)		ESC 3 U ESC 4 1245 (M) 1256 (M) 1357 (M) 1245 (M) 3568 (M)
6 (Form Enter on) Protected* (Form Enter off)	omit test if option 6.a. is present	ESC W * ESC X 1245 (M) 123578 (M) 2468 (M) 1245 (M) 4578 (M)
7 Unlighted Unprotected*		* 2468 (M)
8 Column Tab		ESC 1 1245 (M) 1568 (M)
9 TAB Column Clears		ESC 2 1245 (M) 2568 (M)
10 Single Tab Set (in Cursor)		ESC 0 1245 (M) 56 (M)
11 Cursor Down		ESC B 1245 (M) 27 (M)
12 Cursor Right		ESC C 1245 (M) 1278 (M)
13 Cursor Up		ESC 7 1245 (M) 123568 (M)
14 Cursor Left		BS 48 (M)

Trouble
Analysis
References

- C. Operational Checkout (Continued)
- 3. Complete Checkout (Continued)
 - b. Local Interface - KSR (Continued)
 - (2) PTI Checkout (Continued)
 - (a) Receive Operation (Continued)

Displayed	Character Sent	Marking (M) Codes Sent From TSG	Trouble Analysis References
15 Cursor returns	omit test if option 6.a. is present	ESC G	1245 (M) 1237 (M)
16 Cursor Tabs (to TAB mark)	ESC @	1245 (M) 78 (M)	
17 (Cursor moves to next ln)	HT	14 (M)	
18 Cursor goes Home	ESC H	1245 (M) 47 (M)	
19 *'s ► Clear	ESC J	1245 (M) 2478 (M)	
20 Clear All	ESC R	1245 (M) 2578 (M)	

Perform the following checks on sets with external mode control.

5. Check Receive Data Error signals. (Place INTERFACE SELECT in SEND) Already in SEND 4 Options 14b is present. With data on screen (including protected data) move cursor away from home position. Depress REC key on (PTI) Set.
 - REC lamp should light.
6. Depress RDE test button momentarily - TSG-803.
 - READY lamp should stay lit.
 - REC lamp stays lit on (PTI) Set.
 - Cursor should return to home position.
7. Place INTERFACE SELECT IN REC momentarily.
 - All unprotected data should clear.
8. Check Receive Data Acknowledge signals. Go to local mode. Position cursor away from home position, but ahead of Protected & unprotected data. Enter protected and unprotected data, and return to REC mode.
9. Send ETX, 1, 2 (M) from test set. (CA-on, CA-off)
 - Depress RDA test button momentarily - TSG-803.
 - READY lamp extinguishes.
 - Receive lamp extinguishes on (PTI) Set.
 - Screen is clear of unprotected data from cursor position.
 - Local lamp lights.
 - Cursor stays in same position.
10. Check Force to REC mode. In SEND and again in LOC mode, place INTERFACE SELECT in REC momentarily. Mode should change to REC unless option 15.b. is present.

- C. Operational Checkout (Continued)
- 3. Complete Checkout - KSR (Continued)
 - b. Local Interface - KSR (Continued)
 - (2) (PTI) CHECKOUT (Continued)
 - (b) TRANSMIT OPERATION

Trouble
Analysis
References

PTI Set sending to the TSG-803 Test Set
(All options as factory programmed. See (d) P89 and 90A for exceptions)

When testing the (PTI) Set as a sender, refer to PROCEDURE C (Single Step) (Parity ODD) (P83). PTI Set puts up send selectable.

1. With the (PTI) Set in LOCAL mode, prepare the following message across 1 line:

U*U*

- The proper transmission of individual characters are indicated by the LED lamps on the TSG-803 and should read correctly
2. With the No. 1 Test Message on the screen (P91) send the following characters and verify the correct responses on the TSG-803 - Single Step. Check that cursor does not go Home on SEND, then go Home before sending unless option 27.a. is present.
(FORM SEND & SEND modes)

Displayed	Characters Sent	Marking (M) Code Received on TSG
Protected U	ESC	1245 (M)
	W	123578 (M)
	U	1357 (M)
	ESC	1245 (M)
	X	4578 (M)
Highlighted *	ESC	1245 (M)
	3	1256 (M)
	*	2468 (M)
	ESC	1245 (M)
	4	3568 (M)
Tab mark (set)	ESC	1245 (M)
	0	56 (M)

Note: Repeat test #1 message with FORM SEND mode off. Only the U and the * should be sent except: "U" will not be sent if option 13.c., d., e., f., g., or h. is present. "*" delimiters ESC3 and ESC4 will be sent if option 9.b. is present.

- C. Operational Checkout (Continued)
- 3. Complete Checkout - KSR (Continued)
 - b. Local Interface - KSR (Continued)
 - (2) PTI CHECKOUT (Continued)
 - (b) TRANSMIT OPERATION (Continued)

Trouble
Analysis
References

- 3. With the No. 2 test message on the screen (P91) send the following characters and verify on the TSG-803 - single step.

(SEND mode)

Displayed	Sent	Code Received on TSG
≡	CR unless option	1348 (M)
	CR 10A or 10C	1348 (M)
	LF is present	24 (M)
F _F	FF	34 (M)
E _X	ETX will not be sent if option 8a is present	12 (M)
E _T	Not sent - Note 1 CA does not light on TSG-803 when NC is on. Go back to LOC, Note 2 delete EX from screen and continue. If cursor goes "home on send" step cursor until EOT is sent.	
E _T		38 (M)
GS	Not sent Note 1 - CA does not light on TSG-803 when NC is on. Go back to LOC, Note 2 delete ET from screen and continue. If cursor goes "home on send" step cursor until GS is sent.	
GS		1345 (M)
▶	Not sent Note 1 - CA does not light on TSG-803 when NC is on. Go back to LOC, Note 2 delete GS from screen and continue. If cursor goes "home on send" step cursor until ▶ is sent. SPACE (unless option 13.a., c., f., or g., is present.	
▶		6 (M)
<p><u>Note 1:</u> Characters following message ending characters <u>ETX</u>, <u>EOT</u> & <u>GS</u> may be sent if options 8d, 8f, or 8h are present.</p> <p><u>Note 2:</u> On sets without external mode control, mode automatically changes to LOC unless option 11b is present.</p> <p><u>Note 3:</u> After test message 2 has been sent, restore option 12.a. if 12.b. was enabled for entering protected data from the Test Set.</p>		

- C. Operational Checkout (Continued)
- 3. Complete Checkout (Continued)
 - b. Local Interface - KSR (Continued)

- (2) (PTI) CHECKOUT (Continued)
 - (b) Transmit Operation (Continued)

Perform the following checks on PTI sets with external mode controls (Steps 4, 5, & 6 only).

Trouble
Analysis
References

- 4. Check Transmit Data Error signals.
 Enter 10 character message ending with ETX in LOC mode.
 Depress SEND key on (PTI) Set.
 Send lamp should light.
 Step cursor until ETX is read on lamps 1, 2 (M).
 Depress TDE test button momentarily.
 - READY lamp should stay lit.
 - SEND lamp stays lit.
 - Cursor should return to home position.

- 5. Check Transmit Data Acknowledge signals.
 Enter 10 character message ending with ETX in LOC mode.
 Depress SEND key on (PTI) Set.
 - SEND lamp should light.
 Step cursor until ETX is read on lamps 1, 2 (M).
 Depress TDA test button momentarily.
 - READY lamp extinguishes.
 - SEND lamp extinguishes.
 - REC lamp lights (unless option 16b is present).
 Cursor should stay at same position (unless option 16c is present).

- 6. Check Transmit Abort signal.
 Enter 10 character message ending with ETX in LOC mode.
 Depress SEND key on (PTI) Set.
 Step cursor until ETX is read on lamps 1, 2 (M).
 Depress TA test button momentarily.
 - READY lamp on test set stays on.
 - SEND lamp should turn off.
 - LOC lamp should flash until reset by depressing LOC key.

- 7. Perform the checks in the table below on PTI Sets without External Mode Control. Start in SEND mode and return to SEND after each mode change.

MODE	SENT	MARKING (M) CODE REC'D ON TSG803
LOC*	FF	34
LOC*	ETX	12
LOC*	GS	1345
LOC*	EOT	38

*Except when option 11b is present.

- C. Operational Checkout (Continued)
- 3. Complete Checkout (Continued)
 - b. Local Interface - KSR (Continued)
 - (2) (PTI) CHECKOUT (Continued)
 - (c) External mode (Continued)

(c) External mode (Device Control) interface checks. Connect to 24 pin connector at rear of controller using cable (337683) supplied with test set. Remove cap on 9th key from left unless "EXT release switch" is already provided. Use jumper & probe.

PIN	DESIG	CONDITION	RESPONSE OR CHECK
5	LOCAL lamp	In and out of local	ON (low) in LOC off (high)
7	EXT REL lamp	Apply ground to pin 7	Should light
9	Go Send	In REC connect pins 5 and 9	SEND lamp lights
10	Go LOC	In SEND connect pins 5 and 10	LOC lamp lights
11	Go REC	In SEND connect pins 5 and 11	REC lamp lights
12	EXT REL SW.	Depress (in local)	Brief on (high) pulse
20	RDA MTT	With ETX placed on screen from TSG-803 apply ground to pin 20	Go LOC



- C. Operational Checkout (Continued)
- 3. Complete Checkout (Continued)
 - b. Local Interface - KSR (Continued)

(2) (PTI) CHECKOUT (Continued)

(d) Exceptions to Factory Furnished Options

- 1. REC Option exceptions
PTI Set in REC mode (Procedure B P81.)

OPTION	DISPLAYED	CHAR SENT	TSG-803 MARKING (M) CODE SENT
5b. Accept NULL	N _u	NULL	None
5d. Accept CR	←	CR	1348 M
5f. Accept DELETE	//	DEL	All
6a. Display Sequences	E ₃ ^S U	ESC 3 U	1245 (M) 1256 (M) 1357 (M)
7a. Parity ERROR (Sb) not displayed	*	*	246 (M)

- 2. SEND Option Exceptions
Put characters on screen in LOC mode (if option 12a is present. See note for test 1, P91) Procedure C P83. Perform tests in SEND mode.

OPTION	DISPLAYED	SENT	TSG-803 CODE RECEIVED
8a. End on FF	F _F SPACE	FF NO CA SEE NOTE	34 (M)
8d. Do not end on ETX	E _x Space	ETX Space	12 (M) 68 (M)
8f. Do not end on EOT	E _T Space	EOT Space	38 (M) 68 (M)
8h. Do not end on GS	G _S Space	GS Space	1345 (M) 68 (M)
9a. Highlight delimiters not sent (not in Form Send)	Highlighted*	*	2468 (M)

NOTE: Go to LOC, delete FF from screen and continue checkout. On sets without external mode control the set automatically goes to Local unless Option 11 b. is present. (P90A)

- C. Operational Checkout (Continued)
- 3. Complete Checkout (Continued)
 - b. Local Interface - KSR (Continued)

(2) (PTI) CHECKOUT (Continued)

(d) Exceptions to Factory Furnished Options (Continued)

OPTION	DISPLAYED	SENT	TSG-803 CODE RECEIVED
10a. CR LF Sent	≡	CR LF	1348 (M) 24 (M)
10c. LF Sent	≡	LF	24 (M)
13a. Send All	Protected U * ▶	U * HT	1357 (M) 2468 (M) 14 (M)
13c. Prot. as space	Protected U * ▶	SP * HT	68 (M) 2468 (M) 14 (M)
13d. Prot. as space & HT as space	Protected U * ▶	SP * SP	68 (M) 2468 (M) 68 (M)
13e. Protect as DEL	Protected U * ▶	DEL * HT	All (M) 2468 (M) 14 (M)
13f. Unprotected only	Protected U * ▶	Skip to NC * HT	2468 (M) 14 (M)
13g. HT at end of field	* 5 Protected U's *	* HT *	2468 (M) 14 (M) 2468 (M)
13h. Unprot. only, HT to Space	Protected U * ▶	Skip to NC * Space	2468 (M) 68 (M)

- C. Operational Checkout (Continued)
- 3. Complete Checkout (Continued)
 - b. Local Interface - KSR (Continued)
 - (2) (PTI) CHECKOUT (Continued)
 - (d) Exceptions to Factory Furnished Options (Continued)

Operational

● Mode Option exceptions

11b. Mode after send changes to Receive	When preparing Send tests P88a or 89 the mode after each enabled message ending character FF(8a) ETX(8c) EOT(8e) and GS(8g) should change to REC.
14b. Rec selectable off	READY lamp does not light on TSG when PTI Set is in REC. Perform receive tests P.87 on PTI KSR with TSG-803 transmit interface select in SEND.
15b. No LOC and Send mode Override	Mode should not change from SEND or LOC to REC when power switch on TSG-803 is turned off momentarily.
16b. Mode to Local after TDA	With message ending with ETX, set in SEND mode, step to ETX 1, 2 (M), depress TDA on TSG-803. Cursor should go Home.
27a. Home on SEND	With cursor not at Home position, depress SEND key. Cursor should go Home.



C. Operational Checkout (Continued)

3. Complete Checkout (Continued)

b. Local Interface - KSR (Continued)

(2) (PTI) CHECKOUT (Continued)

- (e) Messages to be prepared in LOCAL mode for use in checking Model 40 (PTI) sets sending to a TSG 803

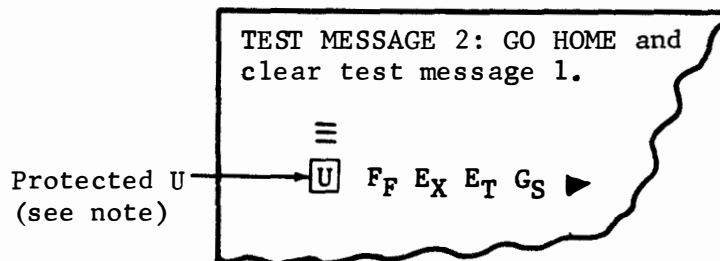
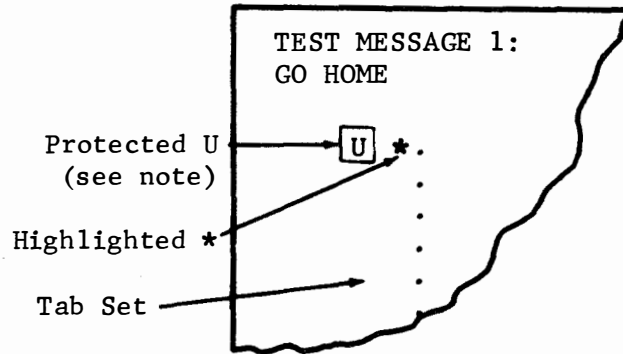

Note: If option 12a. is present enter protected U characters from the TSG-803 with the PTI Set in the REC mode as follows: If option 6a is also present, change option 12.a. to 12.b. and enter protected U's from operator's console.

<u>CHAR</u>	<u>CODE</u>
ESC	1245 (M)
W	123578 (M)
U	1357 (M)
ESC	1245 (M)
X	4578 (M)

Protected data can be cleared by turning off set power when option 12a is present.

C. Operational Checkout (Continued)

3. Complete Checkout - KSR (Continued)

c. On-Line Switched Network Applications

Trouble
Analysis
References

Before proceeding with a complete checkout On Line, perform the complete checkout Off Line.

The checkout procedures are based on the use of a Bell System 202C or equivalent data set which include the following features:

- Reverse Channel
- Auto Answer
- Lighted Keys on Keystrip
- Disconnect on DLE-EOT Sequence

When a Bell System 202R data set is used, the above features are not present, and should be interpreted accordingly (i.e. data set goes to DATA mode when the Exclusion key is pulled up).

Note: The following checkout procedure is applicable with another Model 40 terminal being used in a Switched Network application. This terminal, which will now be acting as a test facility, is called and the following checks are performed. See Chart A for test sequences which can be used when the tester is familiar with detailed on-line checkout procedure. In all of the following checks, display monitor power is to be turned on and the brightness adjusted, unless instructions specifically say to turn off monitor power.

C. Operational Checkout (Continued)

3. Complete Checkout - KSR (Continued)

c. On-Line Switched Network Applications (Continued)

Trouble
Analysis
References

(1) All KSR Terminals, with Printer (if equipped)

(a) Checkout with factory furnished options

1. Depress the LOC key
 - LOC lamp should light
2. Depress the HOME & CLEAR & the TAB CLEAR and FORM ENTER ON (if present) keys.
 - The cursor should return home and the screen should be cleared of all data (operate FORM ENTER off)
3. Prepare Test Message 1 (Page 97) and return cursor to Home position.
4. Depress the TALK key on the data set and originate a call to the Test Terminal in the normal telephone manner.
 - The TALK key should release any other keys but should not light.
5. Depress PRINT ON LINE key on terminals with a printer
 - The PRINT ON LINE lamp should light
6. Depress SEND key
 - SEND lamp should light
7. The called terminal (Test Terminal) should go into DATA mode first
 - High pitched (clearing) tone is sent from the Test Terminal.
8. When clearing tone ends depress DATA key on data set and replace handset
 - DATA lamp should light
 - Message on monitor should be transmitted at 1200 wpm, unless option 3a is present; after 10 second delay (Rev. Chan. withheld by Test Terminal) unless option 4.b. is present, indicated by cursor moving through message.
9. To check ability to switch from Send to Local then back to Send without a disconnect depress LOCAL key during message transmission.
 - Cursor movement should stop when in the Local mode.



C. Operational Checkout (Continued)

3. Complete Checkout - KSR (Continued)

c. On-Line Switched Network Applications (Continued)

(1) All KSR Terminals, with Printer (if equipped) (Continued)

(a) Checkout with factory furnished options (Continued)

Trouble
Analysis
References

10. Depress SEND key
 - Cursor should continue, (unless option 27a is present) stopping one character past ETX (unless option 8d is present on full edit sets)
SEND lamp should extinguish
 - Local lamp should light unless option 11b is present on full edit sets.
 - The Test Terminal should verify that message is received without error and that the Ξ (new line) is received as a $\leq \leq \Xi$ (unless option 10a or 10c is present) on full edit sets only.
 - The printer should copy message without error and feed out 16 lines on ETX (unless option 18a or 18b is present)
11. To check message ending characters prepare message No. 2 (Page 97) in Local mode and Send.
 - The cursor should stop after GS (except on full edit sets when option 8h is present) and mode should go to LOC (except on full edit sets when option 11b is present)
12. Remove GS from message no. 2 and send message again.
 - The cursor should stop after EOT and the mode should go to Receive.
13. Return to Local mode, remove EOT from message 2 and send again.
 - The cursor should not stop of F_F and the call should disconnect on the DLE-EOT sequence.
(DATA lamp off - LOC lamp on - printed paper feeds out unless option 18a is present)
14. Clear screen and depress AUTO key on data set. If not equipped with a printer, depress "REC".
 - The AUTO key should lock down.
15. The Test Terminal should originate a call and send test message no. 1. (If possible the test message should be modified by the Test Terminal to contain odd parity on the first character of the message.)
 - The ringer on the data set should sound
 - The TALK and DATA lamps on the data set should light
 - The Test Terminal should receive a clearing tone

8A.

C. Operational Checkout (Continued)

3. Complete Checkout - KSR (Continued)

c. On-Line Switched Network Applications (Continued)

(1) All KSR Terminals, with Printer (if equipped) (Continued)

(a) Checkout with Factory Furnished Options (Continued)

Trouble
Analysis
References

- The Test Terminal should send carrier but not send data unless they receive reverse channel (unless option 4b is present).
 - The REC lamp should light (PRINT ON LINE is already lit)
 - The message ending with Ex should be received, displayed, and printed without error.
 - The parity error (if sent) should be displayed as an Sb on full edit sets only unless option 7a is present
 - The parity error (if sent) should not cause error symbol to be printed (unless option 19b is present).
 - The printer should feed out 16 lines on reception of ETX (unless option 18a or 18b are present).
 - The REC lamp should extinguish
 - The LOC lamp should light.
16. Return to TALK. Ask Test Terminal to call again and hang up.
17. The ringer should sound until the handset is lifted and the "REC" lamp lights. Ask Test Terminal to send message 1 and depress DATA key. During message reception, depress LOC key.
- Call should disconnect. DATA & TALK lamps off.
 - Printer should feed out paper unless option 18a is present.
18. Depress PRINT ON LINE key.
- It should extinguish.
 - End of Test on sets with no additional features

(b) Exceptions to Factory Furnished Options

Option	Description	Conditions
3a	1050 WPM	Message sent and received at 1050 WPM
4b	no reverse channel	Message should be sent while Test Terminal turns off reverse channel. Reverse channel will not be sent in Receive mode.

C. Operational Checkout (Continued)

3. Complete Checkout - KSR (Continued)

c. On-Line Switched Network Applications (Continued)

(1) All KSR Terminals, with Printer (if equipped) (Continued)

(b) Exceptions to Factory Furnished Options (Continued)

Option	Description	Conditions				
18a	No paper feed out	Paper should not feed out on ETX or when disconnecting.				
18b	Feed out on disconnect only	Paper should not feed out on ETX but should feed out on disconnect.				
19b	Error symbol on Parity Error	The <table border="1" data-bbox="932 758 971 827"><tr><td>A</td></tr><tr><td>A</td></tr></table> monospace or <table border="1" data-bbox="1183 758 1222 827"><tr><td>A</td></tr><tr><td>B</td></tr></table> up-low error symbol should print when odd parity characters are received.	A	A	A	B
A						
A						
A						
B						



- C. Operational Checkout (Continued)
- 3. Complete Checkout - KSR (Continued)
 - c. On-Line Switched Network Applications (Continued)

(2) Conversational Mode (S/R) and Interrupt Control
Perform tests 19 to 29 if conversational mode is furnished

(a) Checkout with Factory Furnished Options

Trouble
Analysis
References

Single Line Test

- 19. Place call to Test Terminal
- 20. Depress the S/R key
 - S/R lamp should light
- 21. Depress HOME and CLEAR keys
- 22. Prepare a single line test message (P97 No. 3)
 - Cursor should go to beginning of line
 - Send lamp should light during message transmission
 - Test Terminal should transmit the same test message however, starting with a LF
 - RECEIVE lamp should light while the response is received

Multiple Line Test (when DC2 is sent with Message) p.95a
(except when option 2a is present)

- 23. Enter DC2 on screen. It should not be sent, then prepare a multiple line test message (P97 No.4)
- 24. Depress HOME key
- 25. Depress SEND key
 - The Send lamp should light during message transmission. Verify that correct message was sent.

Interrupt Key Check

- 26. Request to Receive a test message (P97 No. 1) from Test Terminal.
- 27. To test the Interrupt function while receiving message, depress INTERRUPT key
 - INTERRUPT lamp should light
 - Message should be held up (Reverse Channel turned off, until key is depressed again)

- C. Operational Checkout (Continued)
- 3. Complete Checkout - KSR (Continued)
 - c. On-Line Switched Network Applications (Continued)

(2) Conversational Mode (S/R) and Interrupt Control (Continued)

(b) Exceptions to Factory Furnished Options

Trouble
Analysis
References

Multiple Line Test (when Send on DC2, option 2a is present)

- 28. Enter DC2 on screen
 - Cursor should backspace
 - SEND lamp should light
 - DC2 is transmitted
 - SEND lamp should extinguish
 - Test Terminal should receive DC2
- 29. Prepare a multiple line message (P97 No.4)
Start at first character position after DC2 then go to Send mode.
 - Test Terminal should then receive test message No. 4
 - Send lamp should light during transmission
Concludes checkout if no additional features are present

3. KSR with Full Edit Features

(a) Checkout with Factory Furnished Options

Form Send Mode (send all data and all delimiters)

Go to Local mode

- 30. Prepare test message (P98 No.5)
 - FORM ENTER and HIGHLIGHT lamps should light the first time key is depressed.
 - Lamps should extinguish the second time depressed.
- 31. Depress FORM SEND key (on)
 - FORM SEND lamp should light
- 32. Depress HOME and SEND key, place call to Test Terminal.
 - Message should be sent with delimiters (ESC W, X, 3, 4, 0 sequences)
- 33. Clear screen (It may be necessary to go to LOC mode if (options 8d or 11b are present). Go back to Receive mode.

- C. Operational Checkout (Continued)
- 3. Complete Checkout - KSR (Continued)
 - c. On-Line Switched Network Applications (Continued)

(3) KSR with Full Edit Features (Continued)

(a) Checkout with Factory Furnished Options (Continued)

Form Send Mode (send all data and all delimiters) (Continued)

Trouble
Analysis
References

34. Test Terminal should send back No. 5 message
- Protected U, highlighted * and tab marks should be received as sent unless option 6a is present
 - The N_Y (NULL) < (RET) and $\frac{1}{2}$ (DEL) should not be received (unless 5b, d or f are present) and E_X should be displayed. Mode should switch to LOC

Form Send Mode (OFF)

35. Send message No. 5 again, however with FORM SEND off. Test Terminal should send message back.
- Only highlight delimiters (ESC3, 4 sequences * returned highlighted) should be sent, but not if 9a is present
 - The U will not be sent if option 13c, d, e, f, g, or h are present and the HT should be converted to space unless option 13a, c, e, f, or g are present.
 - Protected U may be converted to space, delete, or not received - see option 13 exceptions, no tab marks will be received, * highlighted (unless options 9a or 6a are present, and message should end with E_X).
36. Move cursor from Home position.
Go to Send mode
- Message should start from cursor position (except when option 27a is present).

Conclusion of
on line checkout

- C. Operational Checkout (Continued)
- 3. Complete Checkout - KSR (Continued)
 - c. On-Line Switched Network Applications (Continued)

(3) KSR with Full Edit Features (Continued)

(b) Exceptions to Factory Furnished Options (Continued)

Trouble
Analysis
References

Option	Description	Conditions
5.b. 5.d. 5.f.	Accept Null Accept CR Accept Delete	Characters will appear in Test Message No. 5 when returned from Test Terminal.
6.a.	Function not performed	On Test Message No. 5 with Form Send U, * & Tab Delimiters will be sent to Test Terminal and returned and will be displayed as E _c WUE _c XE _c 3*E _c 4E _c O.
7.a.	Parity error not displayed	With odd parity character received S _b should not be displayed.
8.d.	Message does not stop on ETX	Message No. 1 will not stop on ETX. Another ETX will be sent at end of page and transmission will continue until LOC key is depressed.
8.a.	Message stops on FF	Message No. 2 stops on FF. FF should then be removed and test repeated.
8.f. 8.h.	Message does not stop on EOT Message does not stop on GS	Test Message No. 2 does not stop on EOT or GS.
9.a.	Highlight delimiters not sent	When Test Message No. 5 is sent and Form Send mode is off, highlight delimiters will not be sent and the * returned from the Test Terminal will not be highlighted.

C. Operational Checkout (Continued)

3. Complete Checkout - KSR (Continued)

c. On-Line Switched Network Applications (Continued)

(3) KSR with Full Edit Features (Continued)

(b) Exceptions to Factory Furnished Options (Continued)

Trouble
Analysis
References

Option	Description	Conditions
10.a. 10.c.	CR LF sent LF sent	The line ending character in Test Message No. 1 will be received at the Test Terminal as a CR LF (⌞≡) sequence or a LF (≡) instead of⌞⌞≡.
11.b.	Mode after Send	The mode after sending the ETX & GS message ending characters in Message No. 1 or 2 will revert to REC instead of LOC.
12.a.	Form Enter disabled	Protected characters cannot be generated in LOC mode. To produce test messages with protected characters option 12b must be temporarily enabled.
13.a.	Send All as displayed	On Test Message No. 5 Form Send off the <u>U</u> and HT will be sent and returned as U and ▶.
13.c.	Send Protected as space ▶ as HT	On Test Message No. 5 Form Send off the <u>U</u> and HT will be sent and returned as SP and ▶.
13.d.	Send Protected as space ▶ as space	On Test Message No. 5 Form Send off the <u>U</u> and HT will be sent and returned as SP and SP.
13.e.	Send Protected as DEL and ▶ as HT	On Test Message No. 5 Form Send off the <u>U</u> and HT will be sent and returned as $\frac{1}{2}$ and ▶.
13.f.	Protected not sent and HT sent	On Test Message No. 5 Form Send off the <u>U</u> should not be sent but the HT should be sent and received as ▶.

C. Operational Checkout (Continued)

3. Complete Checkout - KSR (Continued)

c. On-Line Switched Network Applications (Continued)

(3) KSR with Full Edit Features (Continued)

(b) Exceptions to Factory Furnished Options (Continued)

Trouble
Analysis
References

Option	Description	Conditions
13.g.	Protected char not sent and HT sent after protected field	On Test Message No. 6 and Form Send off the <u>UUUUU</u> should not be sent and the ►(HT) should be sent and received.
13.h.	Protected not sent & HT sent as space	On Test Message No. 5 and Form Send off the <u>U</u> should not be sent but the HT should be sent and received as SP.
27.a.	Cursor Home on Send	When the cursor is not in the Home position and the Send mode is selected the cursor should go Home and Send.

C. Operational Checkout (Continued)

3. Complete Checkout - KSR (Continued)

c. On-Line Switched Network Applications (Continued)

(4) Messages to be prepared on screen in LOCAL mode

TEST MESSAGE # 1

```
U*U* ----- 70 chars. ----- ≡
                10 lines of spaces
U*U* ----- 70 chars. ----- EX (ETX)
```

TEST MESSAGE # 2

```
U*U* GS(GS) ET(EOT) FF(FF) DL(DLE) ET(EOT)
```

TEST MESSAGE # 3

```
THIS IS A SINGLE LINE TEST MESSAGE < (RET)
```

TEST MESSAGE #4

```
Sp THIS IS A MULTIPLE LINE TEST < ≡
TO CHECK CONVERSATIONAL MODE < ≡
FOR TURNAROUND OPERATION D4(DC4)
```

TEST MESSAGE # 5

```
[U] (* • ► NU (NULL) < (RET) // (DEL) EX (ETX)
      .
      .
      .
      .
```

'Go home and clear Test Message No. 1

Note: If option 12a is present, change option to 12b. Be sure to restore to option 12a, if change was made.

TEST MESSAGE #6

```
* [U U U U U] * EX(ETX)
```

- C. Operational Checkout (Continued)
- 3. Complete Checkout - KSR (Continued)
 - c. On-Line Switched Network Applications (Continued)

- C. Operational Checkout (Continued)
- 3. Complete Checkout - KSR (Continued)
- c. On-Line Switched Network Applications (Continued)

(5) CHART A
 SWITCHED NETWORK APPLICATIONS
OPTIONS FACTORY PROGRAMMED

1. ALL KSR SETS (Common Tests)

Step	<u>Terminal Under Test</u> KSR Set	<u>Test Terminal</u>
1,2,3	Prepare test message #1. U*U* ---- ≡ 70th character position 10 LINES OF SPACES U*U* ---- E _X 70th character position	
4 5,6,7 8	Originate Call → Depress SEND (P.O.L.) and DATA keys ← Message held up for 10 seconds (unless option 4b is present), then sent at 1200 WPM (unless → option 3a is present)	Call established Depress DATA and INTERRUPT (withhold reverse channel for 10 seconds) 1st part of message received
9,10	Depress LOCAL momentarily → during test message Send rest of message → Go to Local mode on ETX (unless option 11b is present)	Received message stops momen- tarily Receive and store remainder of message #1 Goes to Local mode on ETX Test Terminal must verify that CR CR LF was sent (unless options 10a or 10c are present)
11	Prepare test message #2 U*U* G _S (GS) E _T (EOT) F _F (FF) D _L (DLE) E _T (EOT)	CR LF for 10a, & LF for 10c
12,13	Send message → Mode returns to LOCAL after GS (unless option 11b is present), to RECEIVE after EOT disconnects after DLE-EOT	Receives message and disconnects

Note: See pages 93-98 for detailed operation,
option, exceptions and Trouble Analysis references.

- C. Operational Checkout (Continued)
- 3. Complete Checkout - KSR (Continued)
- c. On-Line Switched Network Applications (Continued)

(5) Chart A (Continued)

<u>Step</u>	<u>Terminal Under Test</u> KSR and RO Sets	<u>Test Terminal</u>
14,15 1	Auto Answer Mode Data Set in Auto Mode Message received ← Same as originally send from KSR Set	Originate call Home & Send Test message #1 back to terminal under test Send message
16	Return to talk and disconnect (hang up)	Return to talk and disconnect (hang up)
18-22	<p style="text-align: center;">2. Conversational Mode</p> <p style="text-align: center;">KSR Set</p> Conversational Mode Single Line message test message #3 THIS IS A SINGLE LINE TEST MESSAGE ← (RET) Send message →	Message received Test Terminal responds by sending ≡ then returns received single line message

- C. Operational Checkout (Continued)
- 3. Complete Checkout - KSR (Continued)
- c. On-Line Switched Network Applications (Continued)

(5) Chart A (Continued)

<u>Step</u>	<u>Terminal Under Test</u> KSR Set	<u>Test Terminal</u>
23-25	Conversational Mode Multiple line test message #4 (unless option 2a is present) D ₂ (DC2), then add THIS IS A MULTIPLE LINE TEST < ≡≡≡ TO CHECK CONVERSATIONAL MODE < ≡≡≡ FOR TURN AROUND OPERATION DC4 Send message → ←	Message received Test Terminal responds
26,27	Interrupt Mode Receive message ← Depress Interrupt key → Depress Interrupt key again → Clear Screen	Home & Send test message #1 Transmission stops Transmission continues to end of message

C. Operational Checkout (Continued)
 3. Complete Checkout - KSR (Continued)
 c. On-Line Switched Network Applications (Continued)

(5) Chart A (Continued)

3. KSR with Full Edit

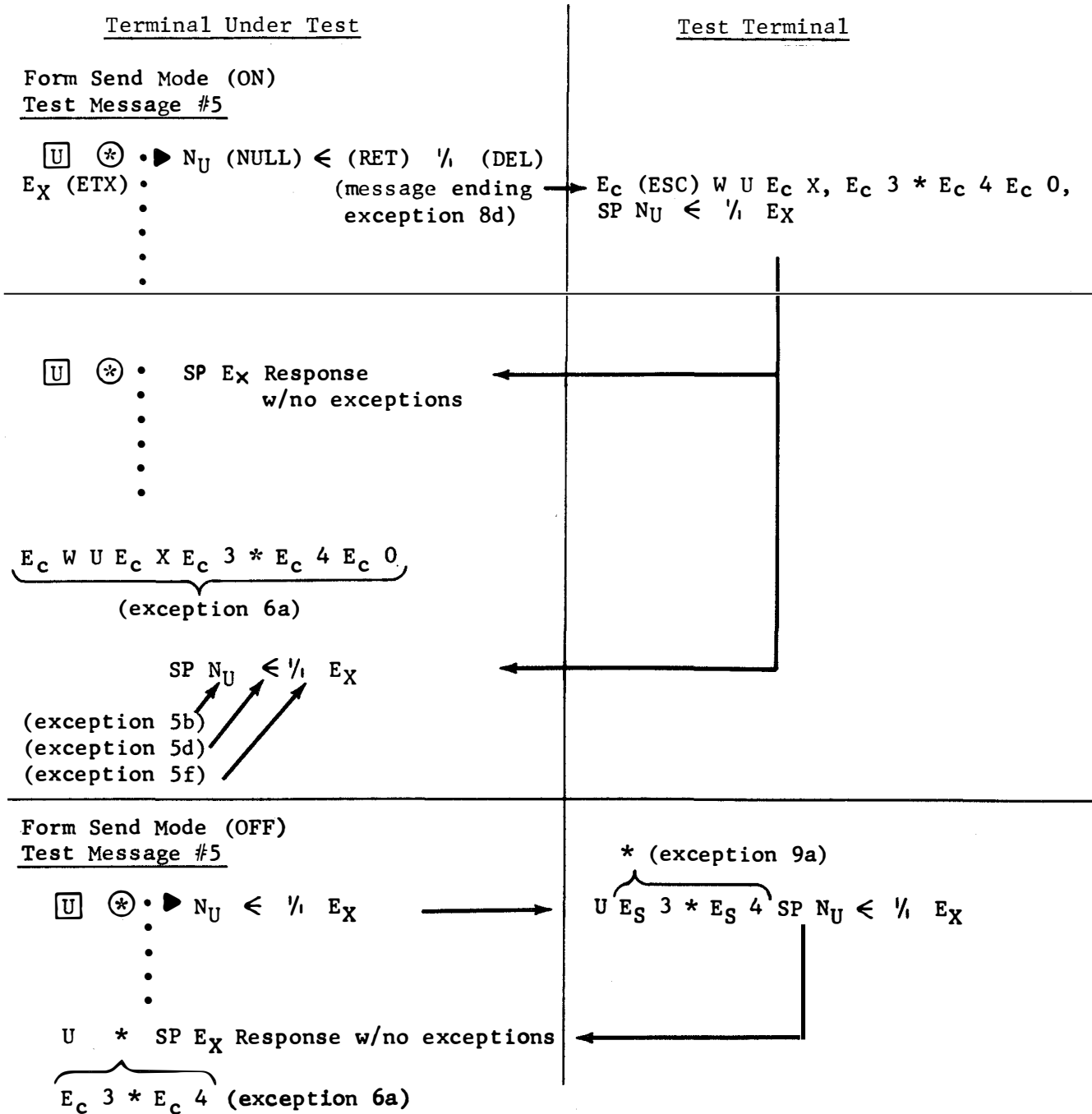

C. Operational Checkout (Continued)
 3. Complete Checkout - KSR (Continued)
 c. On-Line Switched Network Applications (Continued)

(5) Chart A (Continued)

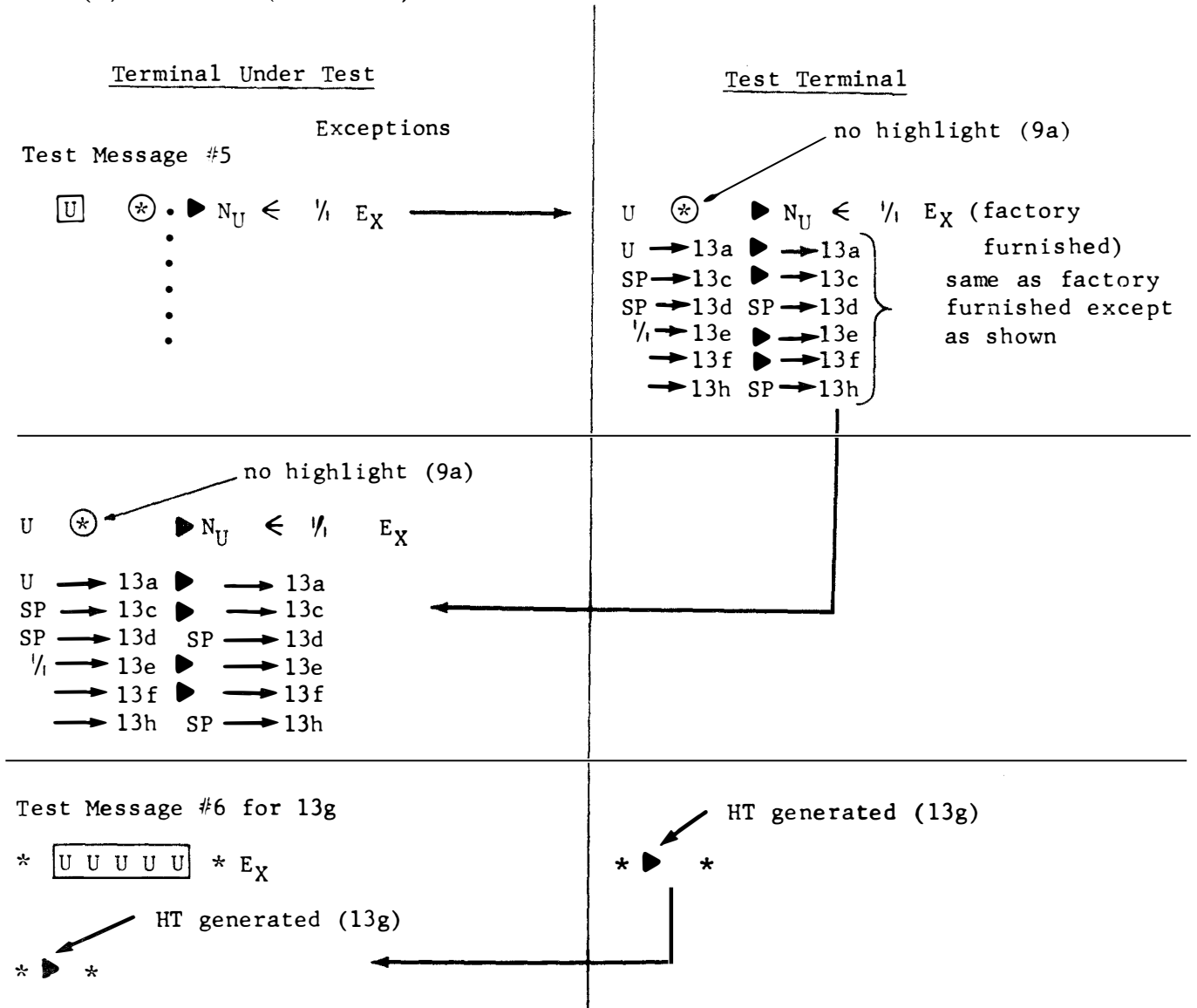

- C. Operational Checkout (Continued)
- 3. Complete Checkout - KSR (Continued)
 - c. On-Line Switched Network Applications (Continued)
- 4. Complete Local and On-Line Checkout RO Printer Terminals

Trouble
Analysis
References

a. Checkout with factory furnished options

- (1) With power turned on (see P. 63 for switch locations) depress the IN SERVICE key and then the PAPER button momentarily.
 - The IN SERVICE key should light.
 - Paper should feed out while PAPER button is held down.
- (2) Depress TRANS START key then after a few seconds depress again.
 - The key should light and the character set should be printed repeatedly.
 - The key should extinguish and printing should stop.
- (3) Lift handset and when dial tone is heard depress DATA key & TRANS START key.
 - Printer motor should turn on.
 - TRANS-START lamp should not light (unless option 26a is present).
 - After approx 15 seconds, paper should feed out (unless option 18a or 18b are present).
- (4) Depress TALK key and Originate Call to Test Terminal (See P. 63 for general instructions)
 - DATA lamp should extinguish.
- (5) Test Terminal sends clearing tone, terminal under test depresses DATA key and Test Terminal sends RO test message (see P. 107).
 - DATA lamp lights at terminal under test.
 - The complete message should be received without error. See exceptions (options 19a, 25a and 25c) that may occur on the 1st * (odd parity).
 - Paper should feed out at end of message (unless option 18a or 18b are present).
- (6) Test Terminal should turn off carrier to disconnect call.
 - After 12-15 sec DATA lamp should extinguish.
 - Paper should feed out on disconnect (unless option 18a is present).

- C. Operational Checkout (Continued)
- 3. Complete Checkout - KSR (Continued)
 - c. On-Line Switched Network Applications (Continued)
- 4. Complete Local and On-Line Checkout RO Printer Terminals (Continued)

Trouble
Analysis
References

a. Checkout with factory furnished options (Continued)

- (7) With the printer cover open, depress AUTO key on Data Set.
 - AUTO key should lock down.
 - The IN SERVICE lamp should not light.
- (8) Test Terminal should call and send repeat "FOX" test message.
 - Ringer should sound at terminal under test.
 - DATA & TALK lamps should light until lid is closed.
 - Test Terminal should go to data mode after clearing tone is received from RO and send message.
- (9) Terminal under test depresses INTRPT key on, then off.
 - The message should stop while INTRPT key is on.
- (10) The call should be disconnected after the 20 line message is received without error.

C. Operational Checkout (Continued)

3. Complete Checkout - KSR (Continued)

c. On-Line Switched Network Applications (Continued)

4. Complete Local and On-Line Checkout RO Printer Terminals (Continued)

b. Exceptions to Factory Furnished Options

Option	Description	Conditions				
3a	1050 baud	Send & Receive data speed				
18a	No paper feed out	Paper does not feed out on any signal				
18b	Paper FO of 16 lines on loss of DCD	When carrier is lost or not received in Data Mode				
19a	Symbol on Even V.P. Error	Error Symbol <table border="1" style="display: inline-table; vertical-align: middle;"><tr><td>A</td></tr><tr><td>A</td></tr></table> or <table border="1" style="display: inline-table; vertical-align: middle;"><tr><td>A</td></tr><tr><td>B</td></tr></table> printed when error (odd parity) is detected	A	A	A	B
A						
A						
A						
B						
25a	Odd parity Null Char. Sent to Printer	Null character sent to Printer on errored character				
25c	Data Error lamp turns on	Lamp will turn on at the first * in the RO message (has odd parity). Depress key to extinguish.				
26a & 26c	Trans Start coded and sent	With call established to Test Terminal equipped to recognize discrete calling code, go to DATA mode. Depress TRANS START key. TRANS START key lights during discrete calling code transmission. Test Terminal responds with a data message if code was recognized.				

- C. Operational Checkout (Continued)
- 3. Complete Checkout - KSR (Continued)
 - c. On-Line Switched Network Applications (Continued)
- 4. Complete Local and On-Line Checkout RO Printer Terminals (Continued)
 - c. Prepared RO Test Messages

- RO Buffer Test Message (Tape Pre-punched or Pre-recorded)

* ≡	}	60 lines	1st * only should have odd parity 2,4,6 (M)
U ≡			
* ≡			
U ≡			

{	QUICK BROWN FOX-----≡
	QUICK BROWN FOX-----≡
	QUICK BROWN FOX-----ETX

15 lines of 80 characters per line

- RO Fox Message (Tape Pre-punched or Pre-recorded)

Quick brown fox message
(20 lines 80 character lines ending with DLE-EOT)



D. TROUBLE ISOLATION



D. TROUBLE ISOLATION

1. General

- Trouble isolation is based on the use of a series of questions to determine possible causes for the trouble. Instructions are then provided (depending on the response to the questions) on tests to be performed and on other actions to be taken (adjustments or replacement of components) to correct the trouble.
- Access to, and location of, test switches, test indicators, and fuses are shown in Section F. 2., Page 155. Component replacement and conversions are shown in Section F.1. and F.3.
- The first List of Questions (ie the "20" Questions) are intended for use by a Test Terminal or customer in order to determine general areas of trouble and any specific replacement parts to be carried on the 1st visit by the repairman.
- When the repairman is on location, the trouble analysis table may be used in two ways:
 - Start with the "20 Questions" and proceed until the trouble is located.
 - Start with the complete checkout of the terminal and go directly to the trouble analysis indicated by the checkout step that fails to meet requirements.

CAUTION: WHENEVER A CIRCUIT CARD IS TO BE REPLACED OR A CABLE DISCONNECTED, BE SURE TO TURN OFF ALL POWER TO THE TERMINAL.

- In the event replacement of the component indicated in the trouble analysis or testing instruction does not correct the trouble, several procedures may be followed:
 - Call for assistance in accordance with locally specified procedures.
 - Replace the next higher order of component (ie interconnecting cable, wired frame module or terminal).
- When installing a new card make certain all options are implemented on this card for proper set operation. Invalid option switch combinations can be the cause of a failure in either the original or replacement card.
- Make replacements only in the order indicated and check to verify that the problem has been cured. If not corrected by replacement, install card that was originally in that position. Make sure card is in proper position.

D. TROUBLE ISOLATION (Continued)

1. General (Continued)

Flow chart of test switches, fuses and indicators for terminals used in the Switched Network applications. See Page 155 for locations.

Note: For actual use of the test switches and indicators in isolation of a trouble, refer to "20 Questions" Section D.2.a.

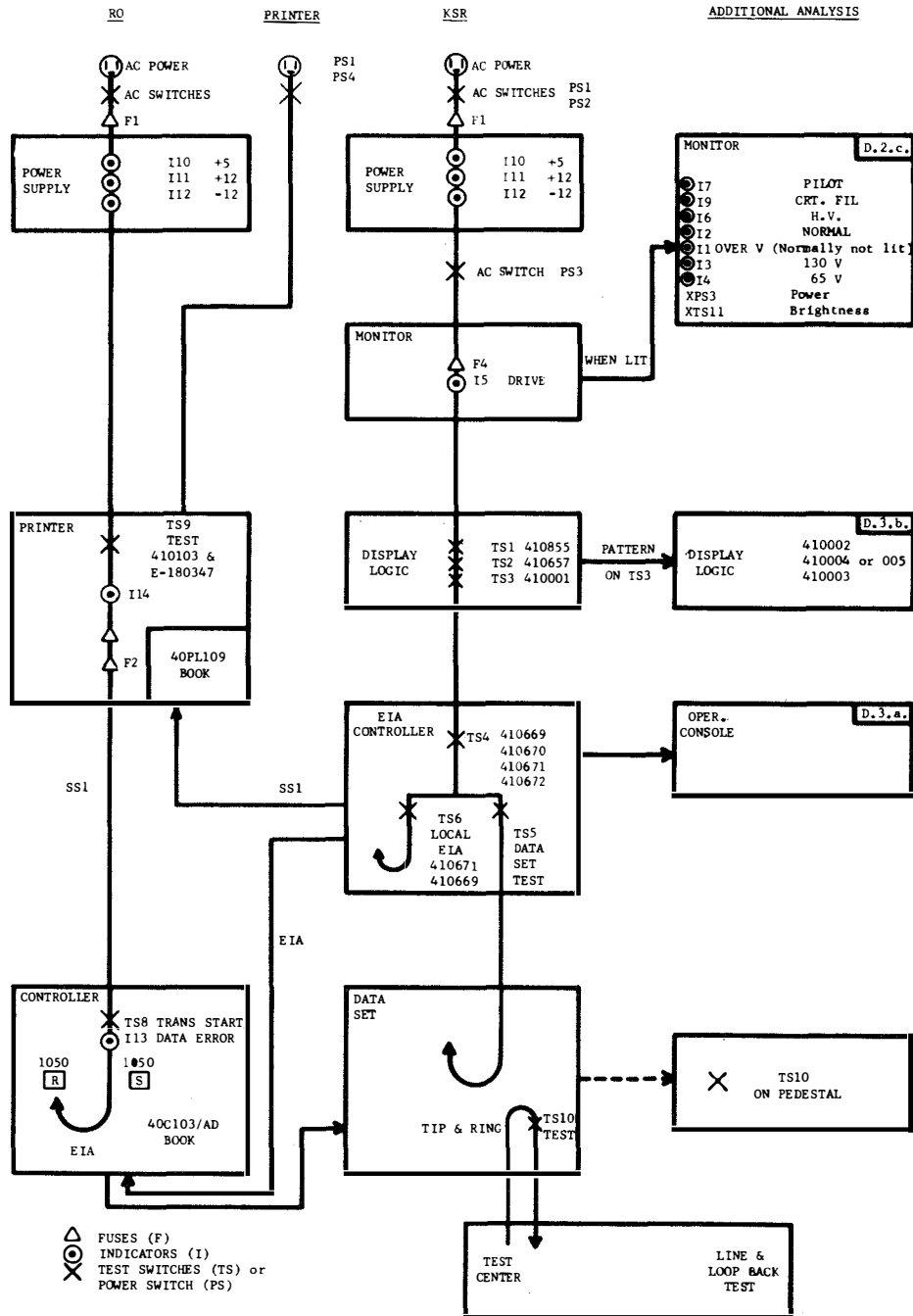

D. TROUBLE ISOLATION (Continued)

1. General (Continued)

Flow Chart of test switches, fuses, and indicators for sets used in arrangements using PTI interface. See Page 155 for locations.

Note: For actual use of the test switches and indicators, refer to "20 Questions" Section D.2.a.

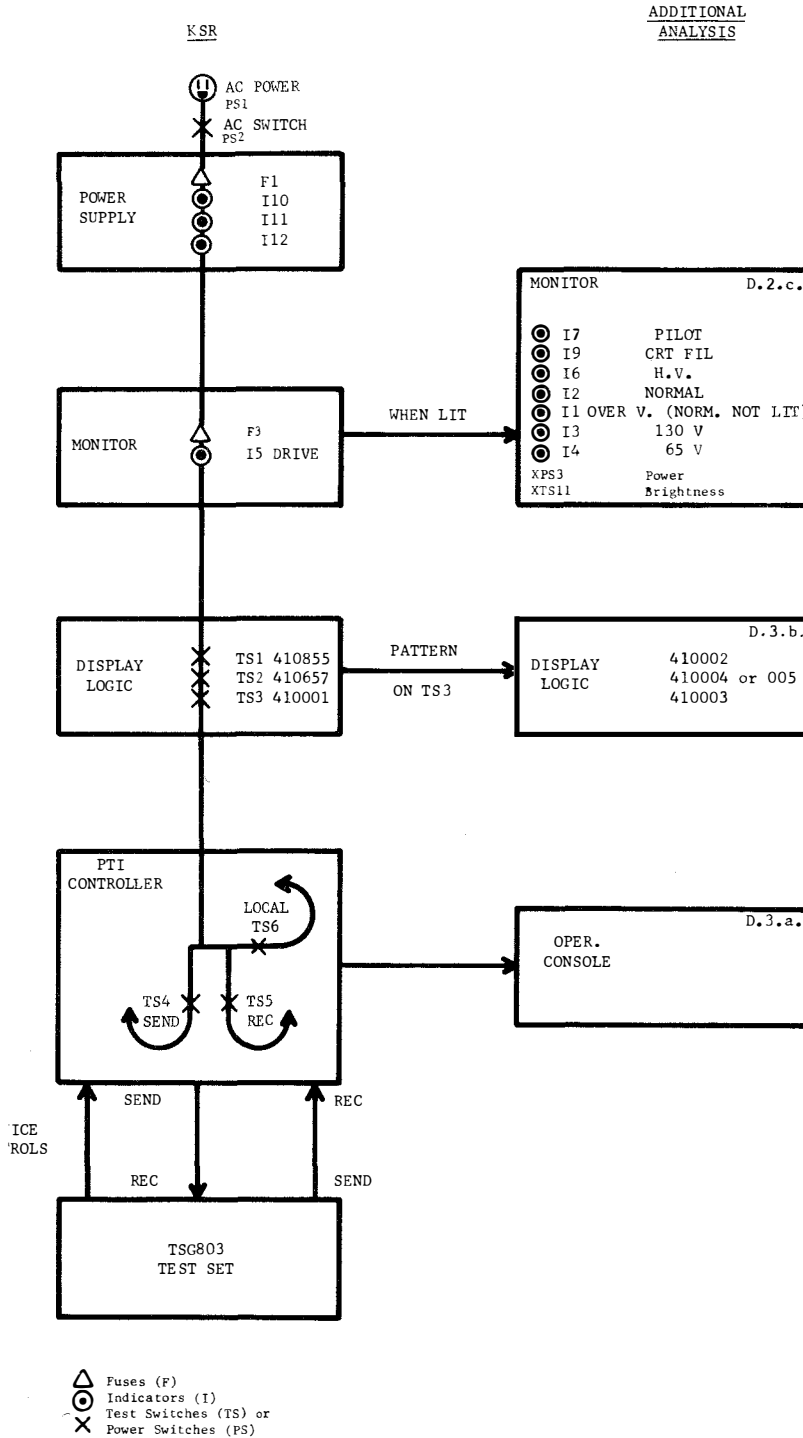

- D. TROUBLE ISOLATION (Continued)
 2. Trouble Analysis
 a. "20 Questions"

MODEL 40 KBD-DISPLAY WITH AND WITHOUT PRINTER & RO SET & PRINTER UNIT

<u>QUESTIONS</u>	<u>YES</u>	<u>NO</u>	<u>Additional Analysis or Testing (Sec. & Page)</u>
1. Does set have a monitor?	Go to 1.a.	Go to 12	
2. Is cursor displayed on monitor? (Monitor switch on and brightness turned up.)	Go to 6	Go to 3	
3. Is AC power on? (Is any lamp on Opcon lit?) Is fan moving air?	Go to 4	a. AC power problem (Is AC cord plugged in and power switches ON?) PS1, 2, or 4 b. Check power supply.	D.2.b.(111)
4. Is red drive lamp I5 lit in monitor?	Go to 5	+5V problem in power supply or display logic problem.	D.2.b.(111) D.3.b.(122)
5. Can raster be displayed?	Display Logic Problem	Monitor problem	D.3.b.(122) D.2.c.(112)
6. Can all data (including editing functions) be input from Opcon to monitor on any segment?	Go to 7	Power supply, Opcon or Logic problem.	D.2.b.(111) D.2.h.(118) D.3.b.(122) D.2.d. (EIA, 114) D.2.g. (PTI, 117)
7. Can data be input from Opcon to monitor on all segments?	Go to 8	Display Logic Problem	D.3.b.(122)
8. Is character image displayed on monitor distorted?	Monitor or Display Logic Problem	Go to 9	D.2.c.(112) D.3.b.(122)

- D. TROUBLE ISOLATION (Continued)
- 2. Trouble Analysis (Continued)
 - a. "20 Questions" (Continued)

MODEL 40 KBD-DISPLAY WITH AND WITHOUT PRINTER & RO SET & PRINTER UNIT (Continued)

<u>QUESTIONS</u>	<u>YES</u>	<u>NO</u>	<u>Additional Analysis or Testing (Sec. & Page)</u>
9. Does character displayed on monitor correspond to character input from Opcon? (i.e. no input)	Go to 10 (PTI) or 11 (EIA)	Display Logic or Controller Problem	D.3.b.(122) D.2.d. (EIA, 114) D.2.g. (PTI, 117)
10. On PTI does set send and receive properly to system? (Repairman - TSG803)	Place in service.	Send or Rec Problem	D.2.g.(117)
11. Does set have a printer?	Go to 12	Go to 17	
12. Does printer respond properly to print local key on Opcon?	Go to 17	Go to 13	
13. Does set have IN SERVICE key?	Go to 14	Go to 16	
14. Is IN SERVICE key lit?	Go to 15	RO Controller Problem	D.2.f.(116)
15. Does message print correctly when (TS8) Trans-Start key is depressed? (Not in Data mode)	Go to 17	Go to 16	
16. Does type carrier symbol (^A or ^A) print in every _A _g column when (TS9) printer test switch is ON and the cover closed?	a. Printer Problem b. Go to 17	Replace printer	D.2.d.(114) KSR D.2.f.(116) RO D.3.e.(124)
17. Does terminal perform on-line remote attended tests properly?	Place in service.	a. EIA Controller, Line, or Data Set problem. b. RO Controller, Line, or Data Set problem. c. External Controller (Buffer)	D.2.d.(114) D.2.f.(116) D.3.f.(124A) BSP 575-100-352

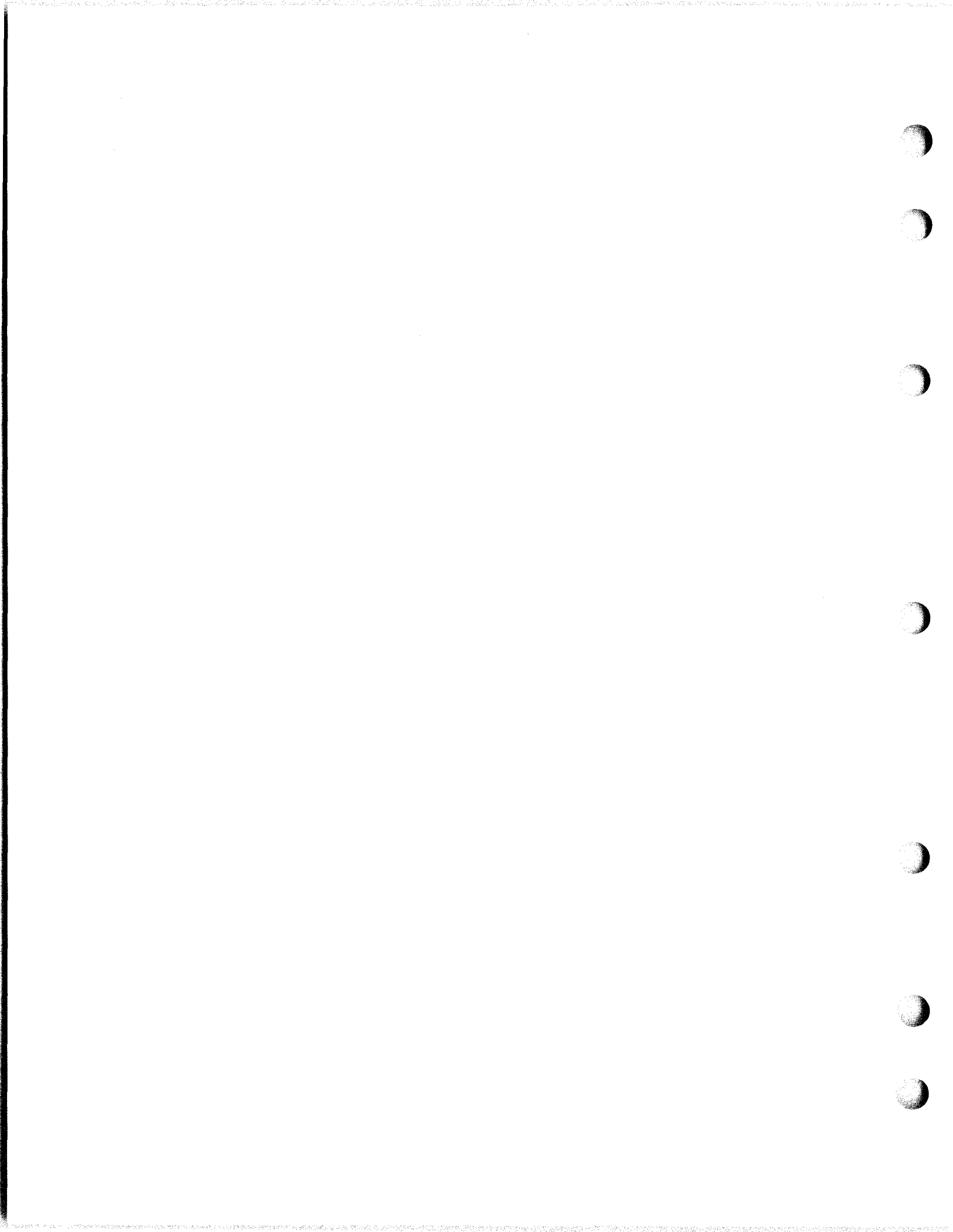

- D. TROUBLE ISOLATION (Continued)
- 2. Trouble Analysis (Continued)
- b. Power Supply

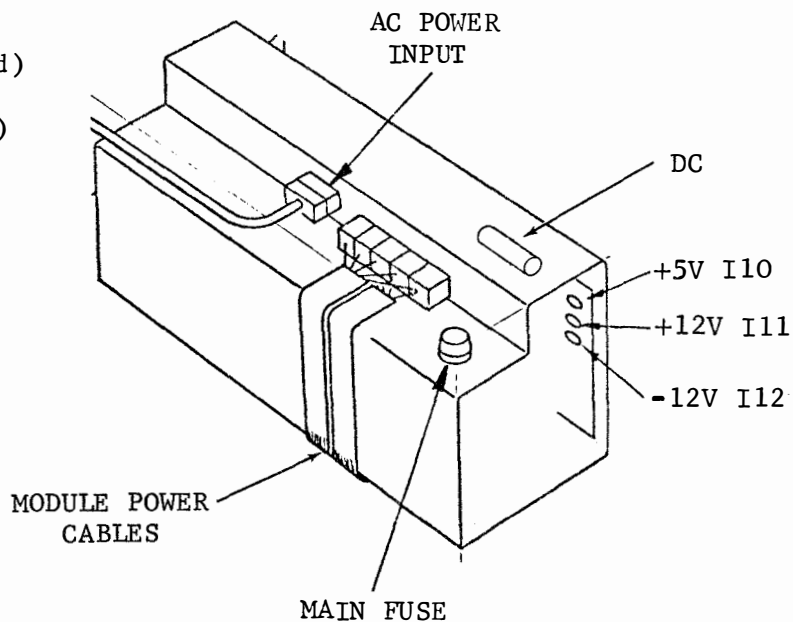

<u>Question</u>	<u>Yes</u>	<u>No</u>
1. Are all neon glow lamps lit for the +5, +12, and -12 voltages?	Power supply OK. Go back to 20 questions.	Go to 2
2. Are all lamps off?	Go to 3	Go to 5
3. Are ventilating fans moving air (cable plugged in)?	Go to 4	Check AC Power & Switches PS1, 2 or 4.
4. Is fuse blown?	Replace fuse and go to 7.	Go to 5
5. Are any lamps off with module power cables removed?	Replace power supply	Isolate to wired frame circuit cards or book.
6. Are all lamps lit?	Place in service	a. Remove module cables and isolate trouble to wired frame, circuitry card or book. b. Replace power supply.
7. Did fuse blow again?	Replace Power supply	Place in service

D. TROUBLE ISOLATION (Continued)

2. Trouble Analysis (Continued)

c. Monitor (Ref. Page 155)

LOCATE SYMPTOMS AND THEN FOLLOW REMEDIES IN ORDER GIVEN (SEE SECTION F. FOR COMPONENT ACCESS UNLESS OTHER PAGE NUMBERS ARE INDICATED). WEAR SAFETY GLASSES.

TURN DISPLAY ON, PS3 LOCAL KEY (LIGHTS), TURN BRIGHTNESS CONTROL FULLY UP TS11 (TO RIGHT), TYPE TEST MESSAGE.

<u>SYMPTOMS</u>	<u>QUESTION</u>	<u>REMEDIES</u>	
		<u>YES</u>	<u>NO</u>
1. No light on screen (follow the sequence on the right).	A. Is drive lamp lit? I5	1. Trouble is in monitor. Go to B.	1. Go to Display Logic Trouble Chart D.3.b. 2. Check connector J9 3. Replace 410656 Card
	B. Is pilot lamp lit? I7	1. Go to C.	1. Check or replace 341578 fuse (F3) 2. Check P5 3. Check AC power
	C. Is CRT filament lit? I9	1. Go to D.	1. Replace monitor 2. Check P5 3. Check CRT socket
	D. Is high voltage lamp lit? I6	1. Check master brightness or J11 connector. 2. Replace 410854 card. 3. Replace 410852 card. 4. Replace 410656 card.	1. Go to E.
	E. Is normal lamp lit? I2	1. Replace 410656 card. 2. Replace 410854 card.	1. Unplug connector P6 and go to F.
	F. Is over-voltage lamp lit? I1 (Normally Off)	1. Replace Q2 on heat sink. 2. Replace 410853 card.	1. Go to G.
	G. Is normal lamp lit? I2	1. Replace Q4 on heat sink. 2. Replace 410854 card. 3. Replace 410656 card.	1. Go to H.

D. TROUBLE ISOLATION (Continued)

2. Trouble Analysis (Continued)

c. Monitor (Ref. Page 155) (Continued)

TURN DISPLAY ON, PS3 LOCAL KEY (LIGHTS), TURN BRIGHTNESS CONTROL FULLY UP TS11 (TO RIGHT), TYPE TEST MESSAGE.

<u>SYMPTOMS</u>	<u>QUESTION</u>	<u>REMEDIES</u>	
		<u>YES</u>	<u>NO</u>
1. (Continued)	H. Unreg. 130V I3 lamp lit. Unreg. 65V I4 lamp lit.	1. Replace Q2 on heat sink. 2. Replace 410853 card.	1. Replace 410852 card.

<u>SYMPTOMS</u>	<u>REMEDIES</u>
2. Raster, but weak or no video or highlight	1. Replace 410855 card in display logic module 2. Replace 410656 card in monitor 3. Replace 410854 card
3. Vertical rolling	1. Replace 410855 card in display logic module 2. Replace 410656 card 3. Replace 410853 card
4. Brightness horizontal line (with video) Depress TS3 and lower brightness to discern (Without video)	1. Check yoke connection P4, connectors J1, J2 & J5, and connections to heat sink transistors Q2, & Q3 2. Replace 410855 card in display logic 3. Replace 410853 card 4. Replace 410656 card 5. Replace 410852 card 6. Replace transistor Q3 on heat sink 1. If unreg. 65V. lamp is out, replace 410852 card 2. Check connection to heat sink transistor Q1 3. Replace 410855 card in display logic module 4. Replace transistor Q1 5. Replace 410853 card
5. Dim vertical line	1. Check yoke connection, P10 2. Replace 410854 card 3. Replace 410855 card in display logic



- D. TROUBLE ISOLATION (Continued)
- 2. Trouble Analysis (Continued)
- c. Monitor (Continued)

TURN DISPLAY ON, LOCAL KEY (LIGHTS), TURN BRIGHTNESS CONTROL FULLY UP (TO RIGHT), TYPE TEST MESSAGE.

<u>SYMPTOMS</u>	<u>REMEDIES</u>
6. Very bright display, no control of brightness	<ul style="list-style-type: none"> 1. Check connector P11 or J11 on 410656 card 2. Replace 410656 card
7. Large horizontal, small vertical	<ul style="list-style-type: none"> 1. Check adjustments 2. Replace 410855 card in display logic module 3. Check over-voltage lamp and if on, replace Q2 on heat sink, then 410853 card if necessary 4. Replace 410854 card
8. Small horizontal, large vertical	<ul style="list-style-type: none"> 1. Check adjustments 2. Check connections to heat sink transistors Q1, Q2, and Q3 3. Replace 410855 card in display logic module 4. Replace Q2 on heat sink 5. Replace 410853 card 6. Replace 410854 card 7. Replace 410656 card
9. Bright vertical line or dot No control of brightness	<ul style="list-style-type: none"> 1. Horizontal yoke and brightness connectors J10 and J11 reversed
10. Fuzzy, dim, oversize, shading flashing no highlighting or 1/2 intensity or other intermittent symptoms not listed above.	<ul style="list-style-type: none"> 1. Check adjustments and connections 2. Replace 410855 card in display logic module 3. Replace 410854 card 4. Replace 410656 card 5. Replace Q4 on heat sink 6. Replace 410853 card 7. Replace 410852 card 8. Replace Q1, Q2, and Q3 on heat sink

Note: If none of above corrects trouble, go back to 20 questions.

D. TROUBLE ISOLATION (Continued)

2. Trouble Analysis (Continued)

d. EIA Controller (Not Full Editing) (Ref. Page 145)

Additional
Analysis
on Testing
(Sec. & Page)

<u>Problem</u>	<u>Yes</u>	<u>No</u>	
1. Can anything be entered from OPCON onto display?	Go to 3	Go to 2	
2. Depress Test key #4 on 410671 Is ? Character displayed on the monitor?	Go to 3	a) Replace 410669 b) Replace 410671 c) Check cable (341740)	
3. Can character be entered from OPCON and displayed properly? (LOCAL MODE)	Go to 4	a) Replace 410672 b) Replace 410669 c) Replace OPCON	P. 119
4. Do Edit Modes and Alarm operate properly?	Go to 5	a) Replace 410669 b) Replace 410672 c) Replace OPCON	P. 119
5. Can unit receive and send on line?	Go to 10	Go to 6	
6. Enter U*U* pattern across first line. With cursor in the Home position, unit in receive and data set in DATA mode, depress test switch #5 on 410671 card. Does the cursor move across the line?	Go to 8	Go to 7	
7. With U*U* pattern on first line & cursor Home, depress test switch #6 on 410671 card. Does cursor move across line and * change to Us?	Check Data Set & Cable	a) Replace 410671 b) Replace 410669	
8. Did the *'s change to U's?	Go to 9	a) Replace 410671 b) Replace 410669	
9. In Data & Rec modes, enter *U*U pattern across first line with cursor in Home position. Depress test switch #5 on 410671 card. Do the U's change to *'s?	Data Set & Line	a) Replace 410671 b) Replace 410669	D.3.f. (124 A)
10. Does terminal have a printer?	Go to 11	Go to 12	

D. TROUBLE ISOLATION (Continued)

2. Trouble Analysis (Continued)

d. EIA Controller (Not Full Editing) (Ref. Page 146) (Continued)

Additional
Analysis
on Testing
(Sec. & Page)

<u>Problem</u>	<u>Yes</u>	<u>No</u>	
11. Does the printer receive properly in response to PRINT ON LINE & PRINT LOCAL?	Go to 12	a) Replace 410670 b) Go to RO Controller c) Check procedure	D.2.f. (116)
12. Does S/R mode work properly?	Go back to "20 Questions"	a) Replace 410670 b) Replace 410669	

D. TROUBLE ISOLATION (Continued)
 2. Trouble Analysis (Continued)
 f. RO Controller

<u>QUESTIONS</u>	<u>YES</u>	<u>NO</u>	<u>Additional Analysis or Testing (Sec. & Page)</u>
1. Is IN SERVICE lamp lit (depressed)?	Go to 2	a. Interlock Connector (lid closed) PS5 b. AC main power plugged in and switches on? PS1, PS4 c. Low Paper lamp lit? I14 d. Power Supply e. Replace RO OPCON f. Replace Controller	D.2.b.(111)
2. Does test pattern copy properly when TS8 (Trans-Start) is depressed in the Local mode?	Go to 2a	a. Printer Problem b. Replace Controller	D.3.e.(124)
2a. Is RO Set connected to a properly operating KSR terminal?	Go to 2b	Go to 3	
2b. Does RO Set receive properly from KSR Set in Local mode?	Place Set in service	Replace Controller	
3. Does Terminal receive Carrier signal (remains in Data mode for more than 15 seconds)?	Go to 4	a. Line or Data Set Problem b. Replace Controller	D.3.f.(124a)
4. Is RO Set coded for Trans-Start?	Go to 6	Go to 5	
5. Is Terminal equipped to send reverse channel?	Go to 7	Go to 9	
6. Is reverse channel received by the Test Terminal?	Go to 8	a. Line or Data Set Problem b. Replace Controller	D.3.f.(124a)
7. Is reverse channel received by the Test Terminal?	Go to 9	a. Line or Data Set b. Replace Controller	D.3.f.(124a)

D. TROUBLE ISOLATION (Continued)
 2. Trouble Analysis (Continued)
 f. RO Controller (Continued)

<u>QUESTIONS</u>	<u>YES</u>	<u>NO</u>	<u>Additional Analysis or Testing (Sec. & Page)</u>
8. Does message get received in response to Trans-Start operation in Data mode?	Go to 10	a. Discrete Calling Code correct? (Option 26a & 26c) b. Replace Controller	
9. Does message get received from remote sender?	Go to 10	a. Line or Data Set Problem b. Replace Controller	D.3.f.(124a)
10. Does Data Error lamp light?	a. Line or Data Set Problem b. Replace Controller	Go to 11	D.3.f.
11. Is message properly received?	Go to 12	a. Line or Data Set Problem b. Replace Controller	D.3.f.(124a)
12. Is terminal equipped with reverse channel?	Go to 13	Place in service	
13. Does INTRPT or overloaded storage stop on-line message reception?	Place in service	a. Line or Data Set Problem b. Replace Controller	D.3.f.(124a)



D. TROUBLE ISOLATION (Continued)

2. Trouble Analysis (Continued)

g. PTI Controller (Continued)

<u>Problem</u>	<u>Yes</u>	<u>No</u>	<u>Additional Analysis or Testing (Sec. & Page)</u>
1. Can anything be entered from OPCON onto display?	Go to 3	Go to 2	
2. Depress LOCAL TEST key (TS6) on 410677. Are any characters displayed? Does Local lamp go out while TSC is depressed?	Go to 3	a. Replace 410675 b. Replace 410674	
3. Can characters be entered and displayed properly?	Go to 4	a. Replace 410672 b. Replace OPCON c. Replace 410674 d. Replace 410002	D.2.h.(118) D.3.b.(122)
4. Do Modes, Edit, and Alarm operate properly?	Go to 5	a. Replace 410675 b. Replace 410672 c. Replace OPCON d. Replace 410002	D.2.h.(118) D.3.b.(122)
5. Depress Receive Test switch (TS5) on 410677. Does any character get displayed?	Go to 6	a. Replace 410675 b. I/O DL c. Replace 410677	D.3.b.(122)
6. Can characters be received properly? (Use TSG803 test set if available)	Go to 7	a. Replace 410677 b. Replace 410674	
7. Does the display respond properly to control characters and sequences?	Go to 8	a. 410674 b. Replace 410675 c. Replace 410678 (if so equipped)	
8. Depress SEND TEST key (TS4) on 410677; does cursor step on depression?	Go to 11	a. Replace 410676 b. Replace 410675	
9. Can characters be sent properly? (Use TSG803 test set, if available)	Go to 10	a. Replace 410677	
10. Can you send proper ESC sequence On Line?	Go to 11	a. Replace 410676 b. Replace 410674 c. I/O DL	D.3.b.(122)
11. Is LF Sequence sent? Does set return to proper mode after end character?	Go back to "20 Questions"	a. Replace 410675 b. Replace 410678 (if so equipped)	

D. TROUBLE ISOLATION (Continued)

2. Trouble Analysis (Continued)

h. KSR Operator Console

	<u>Question</u>	<u>Yes</u>	<u>No</u>	<u>Additional Analysis</u>
1.	Does the Opcon pass the Power Test (D.3.a.)?	Go to 2	Power Supply Pblm.	D.2.b.(111)
2.	Do any operational keys fail to light or extinguish properly or fail to flash under alarm conditions?	Go to 3	Go to 4	
3.	Does the operational key fail in test (D.3.a.)?	Replace Opcon		
4.	Do any keys fail to operate properly when depressed?		1. Display Logic Pblm. 2. Controller Pblm. 3. Replace Opcon	
5.	Do all keys operate properly when depressed?	Opcon OK	1. Replace Opcon 2. Display Logic Pblm. 3. Controller Pblm.	

D. TROUBLE ISOLATION (Continued)

3. Testing

- a. Operator Console Local Loop Back and Power Test

Omitted in this issue

D. TROUBLE ISOLATION (Continued)

3. Testing (Continued)

a. Operator Console Local Loop Back and Power Test (Continued)

Omitted in this issue

D. TROUBLE ISOLATION (Continued)

3. Testing (Continued)

a. Operator Console Local Loop Back and Power Test (Continued)

Power Test

Simultaneously depress the and keys with more force than is required in normal operation. The lamp I8 on the Opcon should light and extinguishes when the keys are released.

Local Loop-Back Test

Simultaneously depress the and '/> keys with additional force turning on the lamp I8. The operational lamps can be turned on and off, or made to flash by depressing the following keys. Ignore any characters that may appear on the monitor during the test.

Note: Occasionally the operational lamps may flash on then off, or the alarm bell may sound when the loop-back test is activated. If this occurs, clear the test by depressing the and keys beyond their normal stop. Then retry the test.

OPERATIONAL LAMP	LIGHTS	EXTINGUISHES
LOCAL	D	EOT
SEND	A	SOH
REC	C	ETX
S/R	G	BEL
INTRPT	F	ACK
FORM SEND	E	ENQ
PRINT ON LINE	J	NEW LINE
PRINT LOCAL	Alpha O	SI
HIGHLIGHT	I	TAB
FORM ENTER	H	← (Cursor Left)
	<u>FLASHES</u>	<u>EXTINGUISHES</u>
REC	<input type="button" value="→"/> (Cursor Right)	ETX
S/R	CURSR RETRN	BEL
PRINT ON LINE	CLEAR	NEW LINE
FORM ENTER	HOME	<input type="button" value="←"/> (Cursor Left)

(After testing operational lamps and TST mode, restore normal operation by depressing and keys simultaneously with additional force.

D. TROUBLE ISOLATION (Continued)

3. Testing (Continued)

b. Display Logic (Continued)

Testing of the Display Logic consists of depressing switches 1, 2, and 3 in that order and noting the displays indicated.

Switch No. 1 located on Card No. TP410855 (See Part F. 2.)

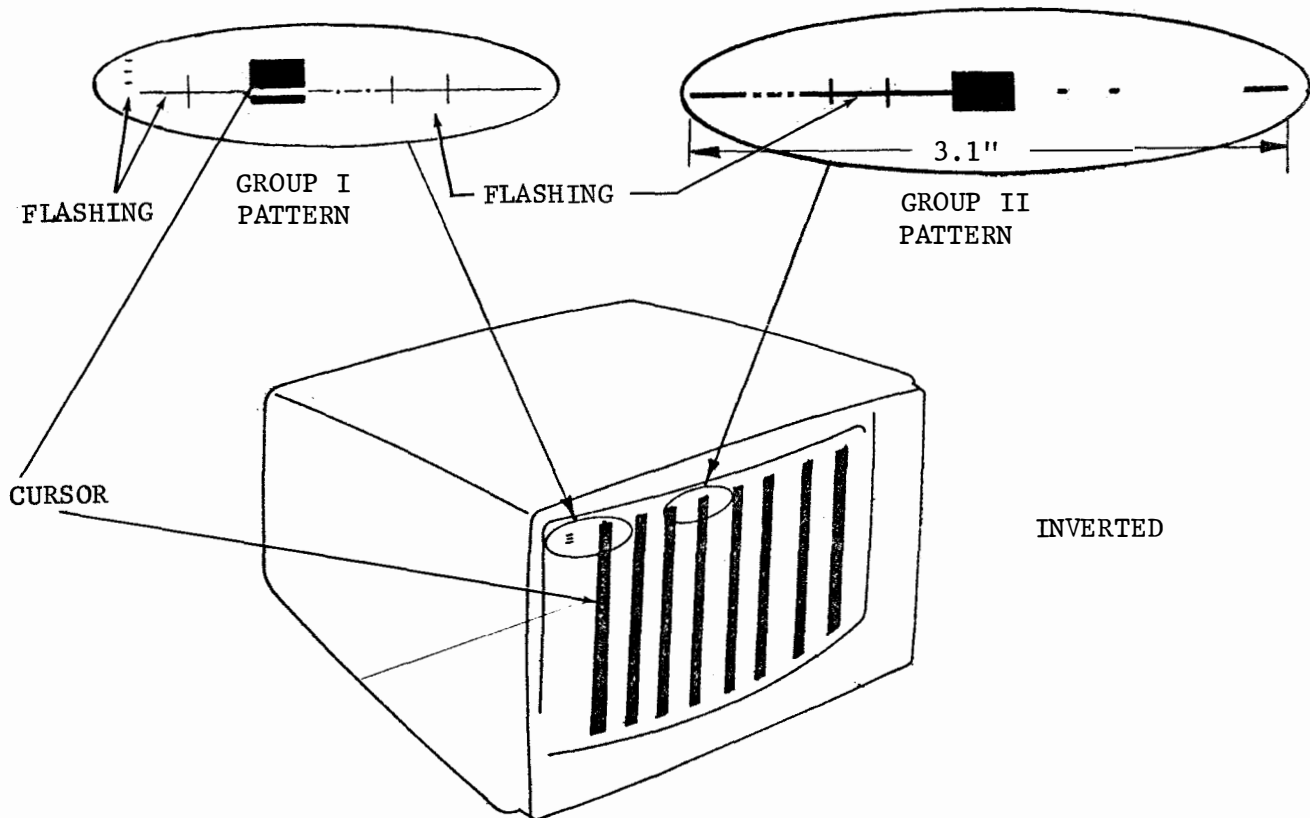

If the correct pattern is not displayed, replace Card No. TP410855 or TP410656.

Notes:

1. Insets are shown actual size
2. Group I consists of the segment indicator and the first 14 characters.
3. Group II consists of characters 23 through 44.

Switch No. 2 located on Card No. TP410657 (See Part F. 2.)

The following characters will alternate across all lines of the display:

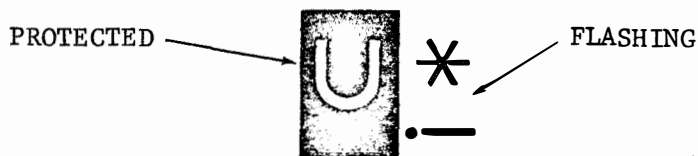

This sequence may appear in reverse order, i.e. *U.

If the correct pattern is not displayed, replace Card No. TP410657.

- . TROUBLE ISOLATION (Continued)
- . Testing (Continued)
- b. Display Logic (Continued)

Switch No. 3 located on card No. TP410001

The * character will appear across all lines of the display when the switch is depressed and held.

Sets containing more than 24 lines will be scrolled to check all segments.

If correct pattern is not displayed, check only for the following error indications?

- If depressing the switch causes one of the following bar patterns, replace the indicated card. If neither the bar pattern nor the * pattern are present, replace the TP410001.

Note: If data appears on the screen that is not sent from keyboard and all above checks are good (1) replace 410004 or 410005 cards in the segment position affected, (2) replace 410002 card. If Display logic tests are OK, go back to "20 Questions," No. 6 or No. 9 for additional analysis.

- The following bar patterns denote the indicated defective card. Disregard anything else on the screen.

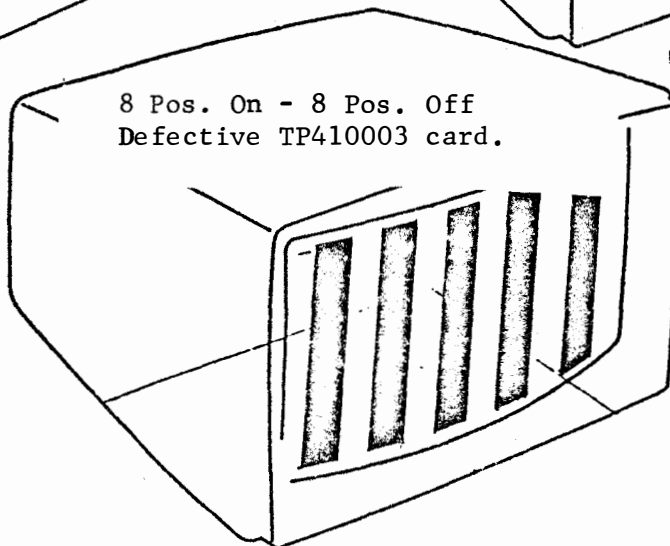
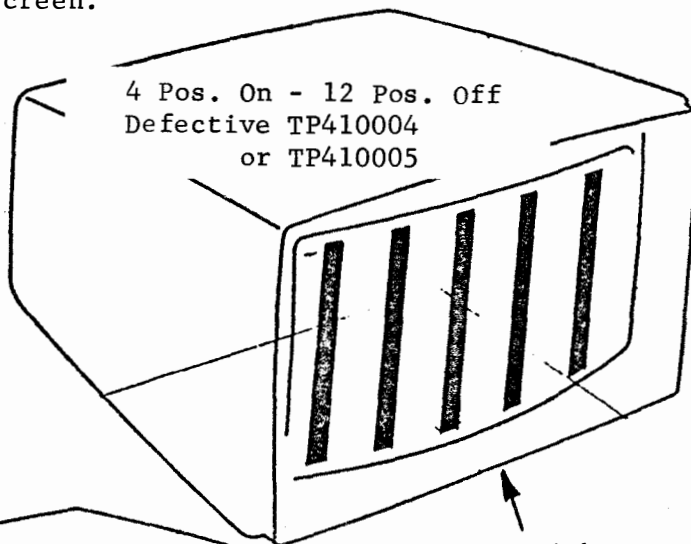
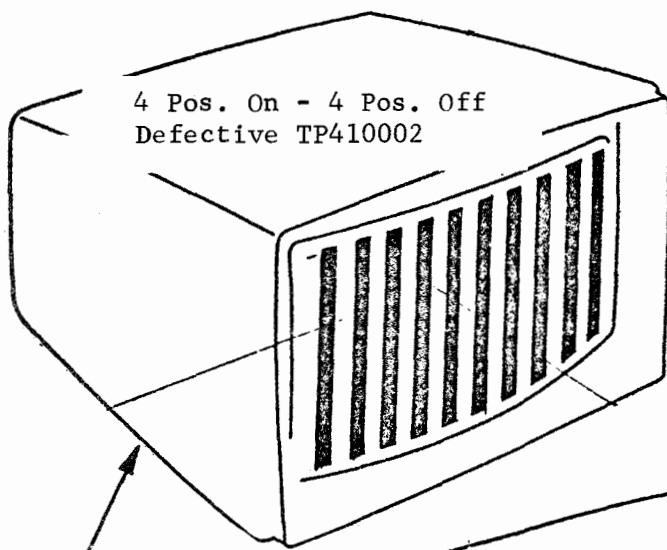

Note: If this pattern appears, remove controller connector and repeat test. Trouble is in controller D. 2.d. (EIA) or g. (PTI) if pattern no longer appears.

- on sets with more than 1 segment, replace card indicated by displayed segment marker.

D. TROUBLE ISOLATION (Continued)

3. Testing (Continued)

e. Printer

To operate TEST switch (TS9), open printer cover and place switch in ON position. Close cover carefully keeping paper taut, as paper will start to advance immediately.

<u>Question</u>	<u>Yes</u>	<u>No</u>
1. Does motor run and paper advance when PAPER button is depressed?	Go to 2	a) AC power problem PS1, PS2, PS4 (interlock PS5 switch, F2 good?) b) SSI line connected? c) Go to 2
2. Does anything print when TEST (SW9) is on and cover is closed?	Go to 3	a) Replace 410640 Card b) Replace 400180 Printer
3. Are error symbols $\begin{matrix} A \\ A \end{matrix}$ or $\begin{matrix} A \\ 8 \end{matrix}$ printed in every column?	Go back to "20 Questions"	Replace 400180 Printer

D. TROUBLE ISOLATION (Continued)

3. Testing (Continued)

f. Data Set and Line (Switched Network Applications)

	<u>Question</u>	<u>Yes</u>	<u>No</u>
1.	Can phone connection be originated and answered in TALK mode in normal manner? (Normal voice clarity & volume?)	Go to 2	Problem with telephone portion of Data Set or phone connection to C.O.
2.	Does TALK lamp light on answered calls?	Go to 3	Data Set problem or D/S not plugged into ac
3.	Does terminal answer call in DATA mode automatically with AUTO key locked down? (P.O.L Lamp on if present or set in REC mode)	Go to 4	Data Set or Controller
4.	Can DATA mode in SEND, REC & S/R or RO modes be established with Test Terminal?	Go to 5	Data Set or Controller
5.	Perform loop back test with Test Terminal. Operate TS10 in TALK mode and hang up. Is test good?	Go to 6	Check Data Loop or replace Data Set
6.	Can extended messages be sent to and received from any remote data terminal without error on repeated calls?	Place in Service	Switched Network problem in Loop C.O., Trunk etc.



E. COMPONENT IDENTIFICATION



E. COMPONENT IDENTIFICATION

General

- This section provides identification and location of replaceable components for all standard model 40 terminals.
- Contents of this section are components (units and unit parts) considered to be readily replaceable in the field for trouble correction.
- Actual replacement of component should be done according to information in the trouble analysis, access and dismantling sections.
- When adjustments or options are affected by replacement of components, appropriate notations in the figure should be observed.
- For your convenience a numerical listing and page cross reference is provided at the end of this section.

E. COMPONENT IDENTIFICATION (Continued)

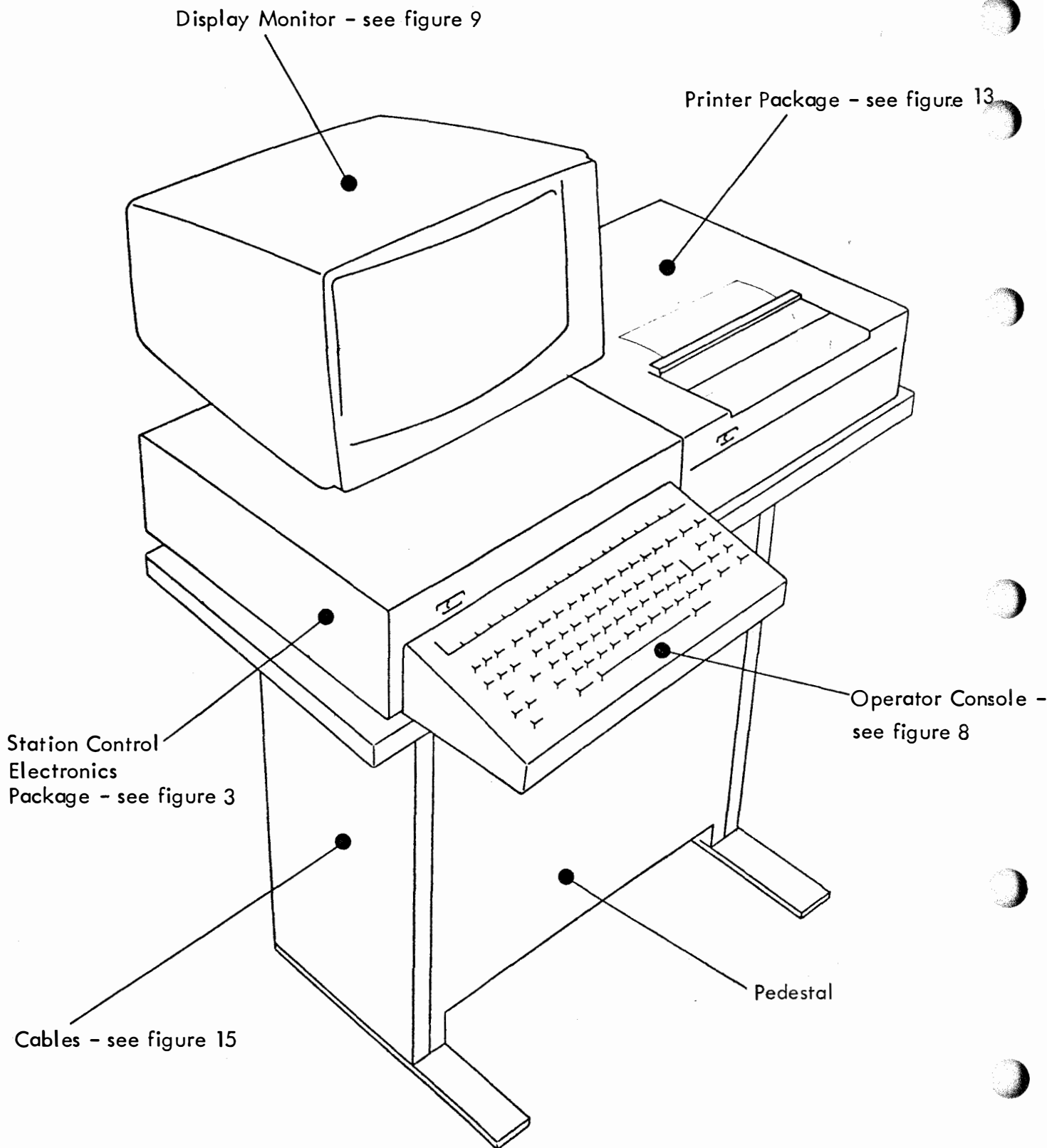

FIGURE 1 - MODEL 40 KEYBOARD SEND-RECEIVE (KSR) WITH PRINTER SET (MAJOR COMPONENT IDENTIFICATION)

E. COMPONENT IDENTIFICATION (Continued)

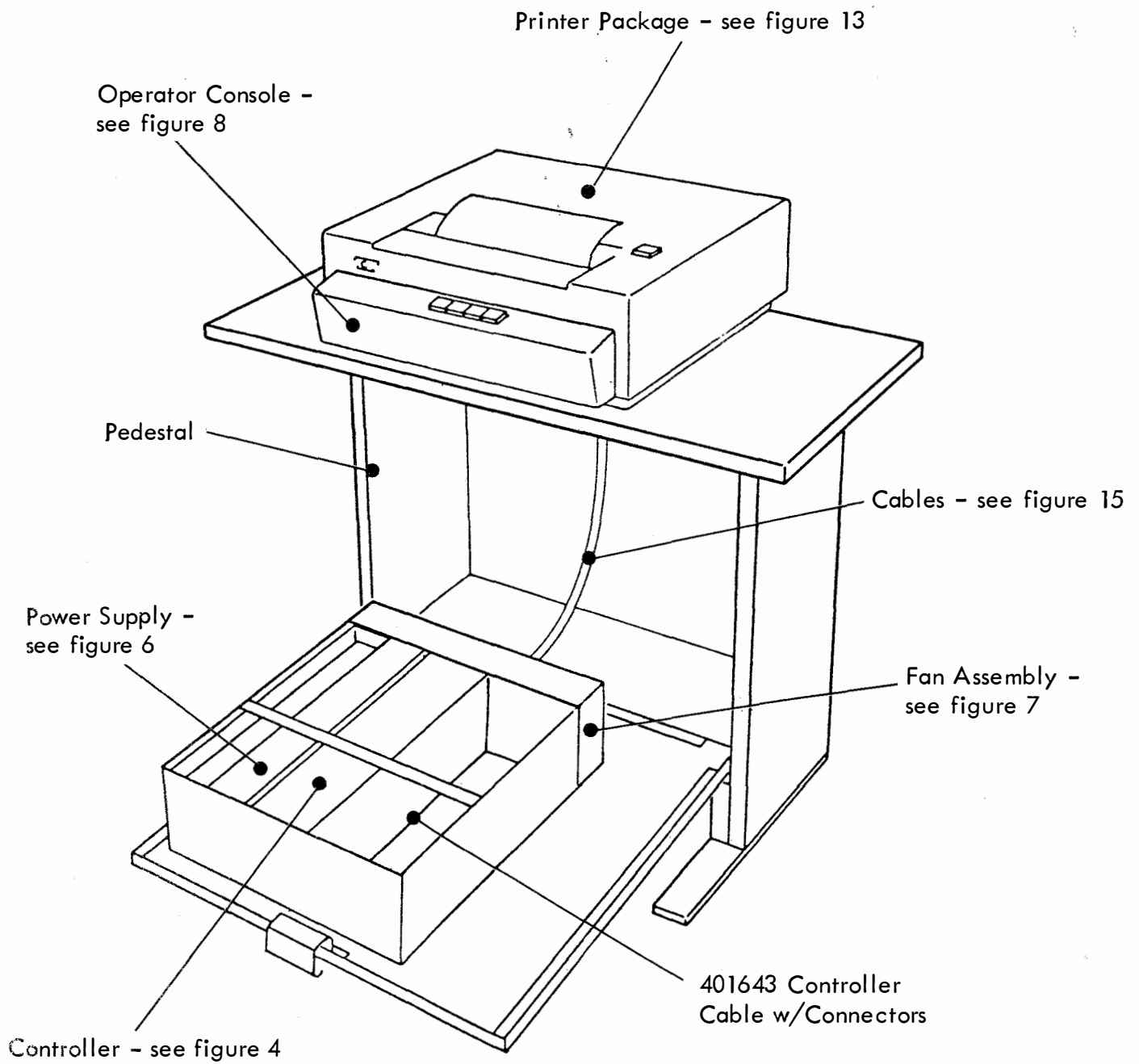
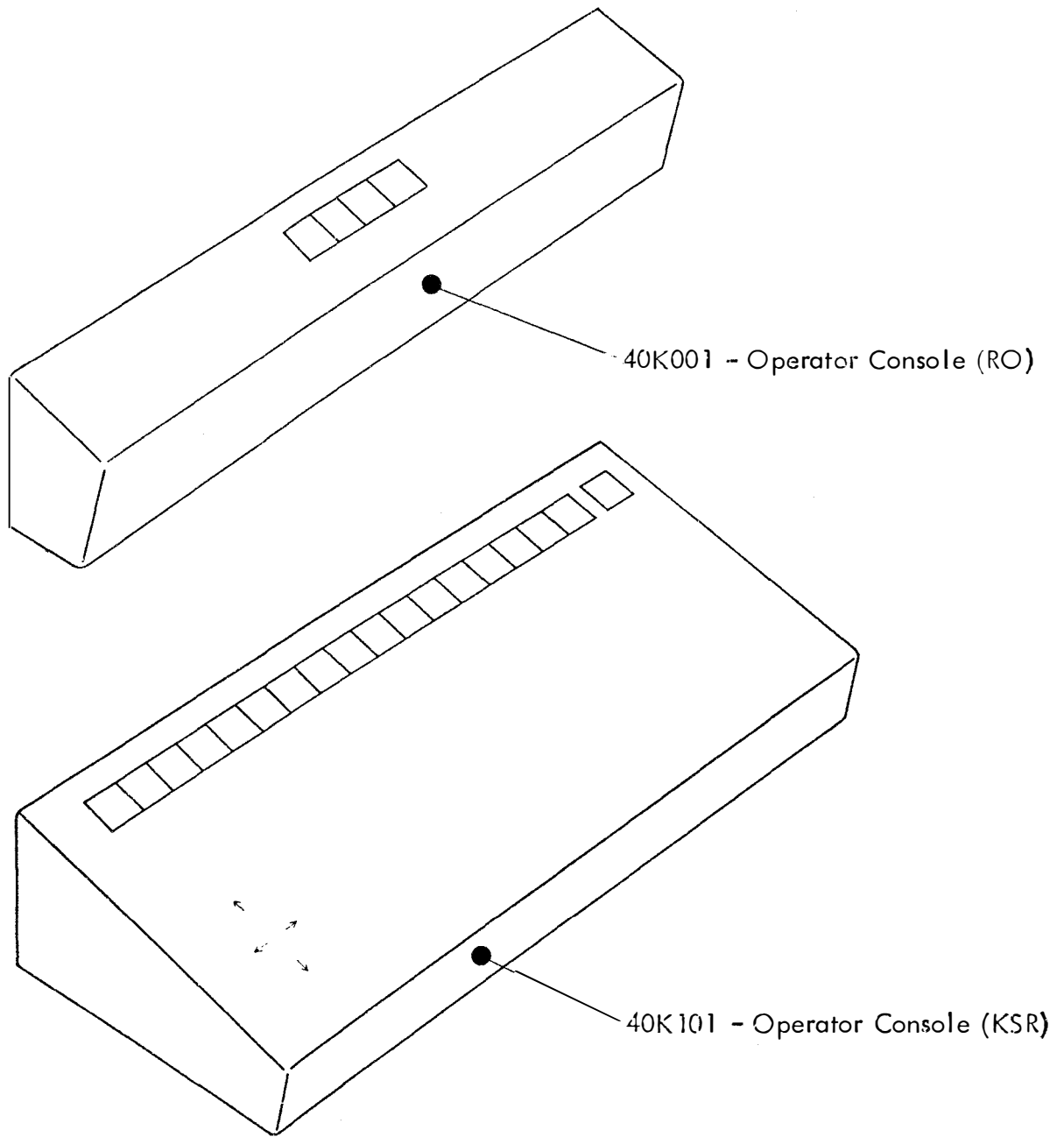

FIGURE 2 - MODEL 40 RECEIVE-ONLY PRINTER (RO) SET (MAJOR COMPONENT IDENTIFICATION)

E. COMPONENT IDENTIFICATION (Continued)

Omitted in this issue.

E. COMPONENT IDENTIFICATION (Continued)



Note: For arrangements or conversions, see appropriate section.

FIGURE 8. OPERATOR CONSOLES

E. COMPONENT IDENTIFICATION (Continued)

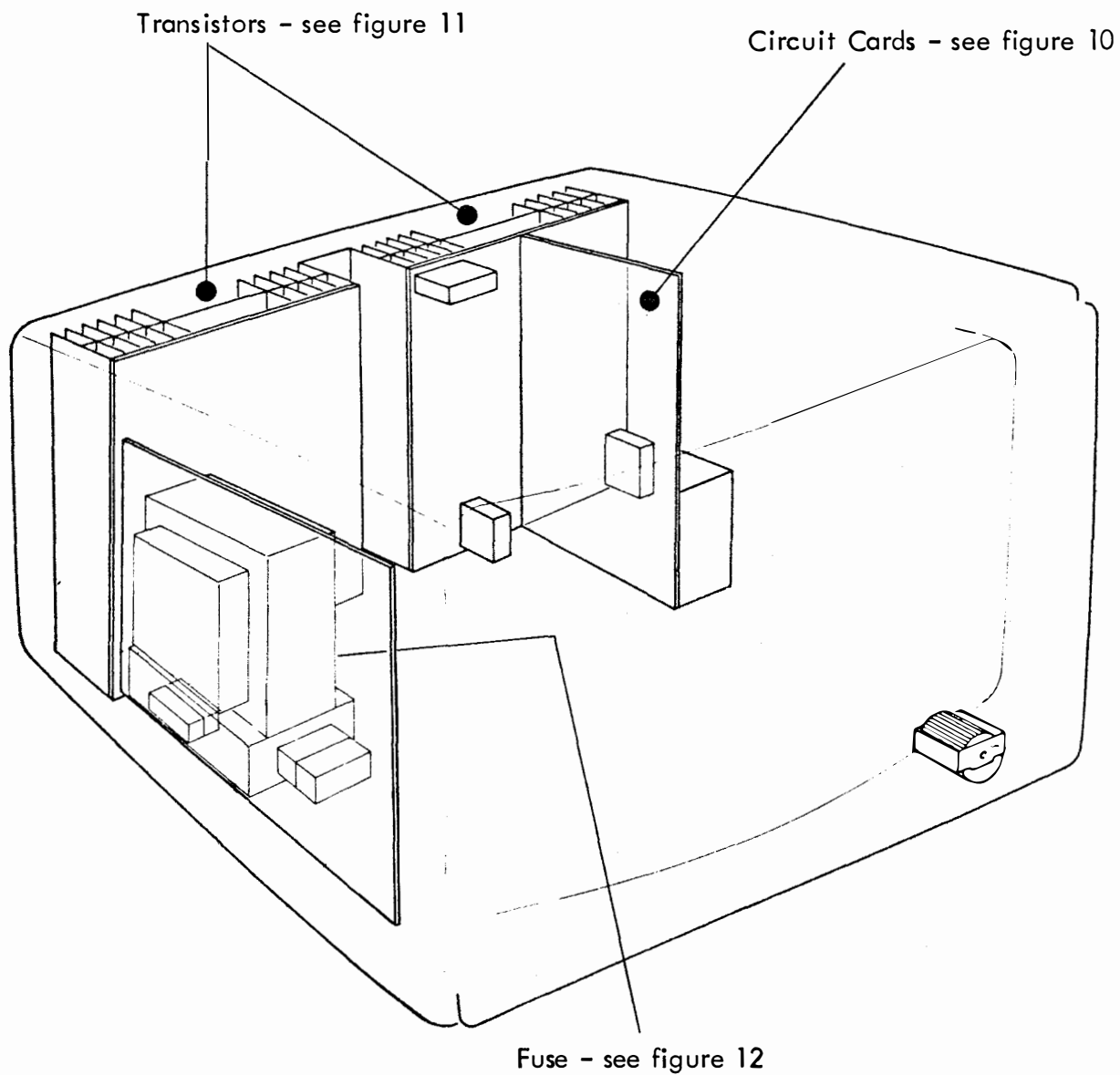

FIGURE 9 - 40MN101 DISPLAY MONITOR

E. COMPONENT IDENTIFICATION (Continued)

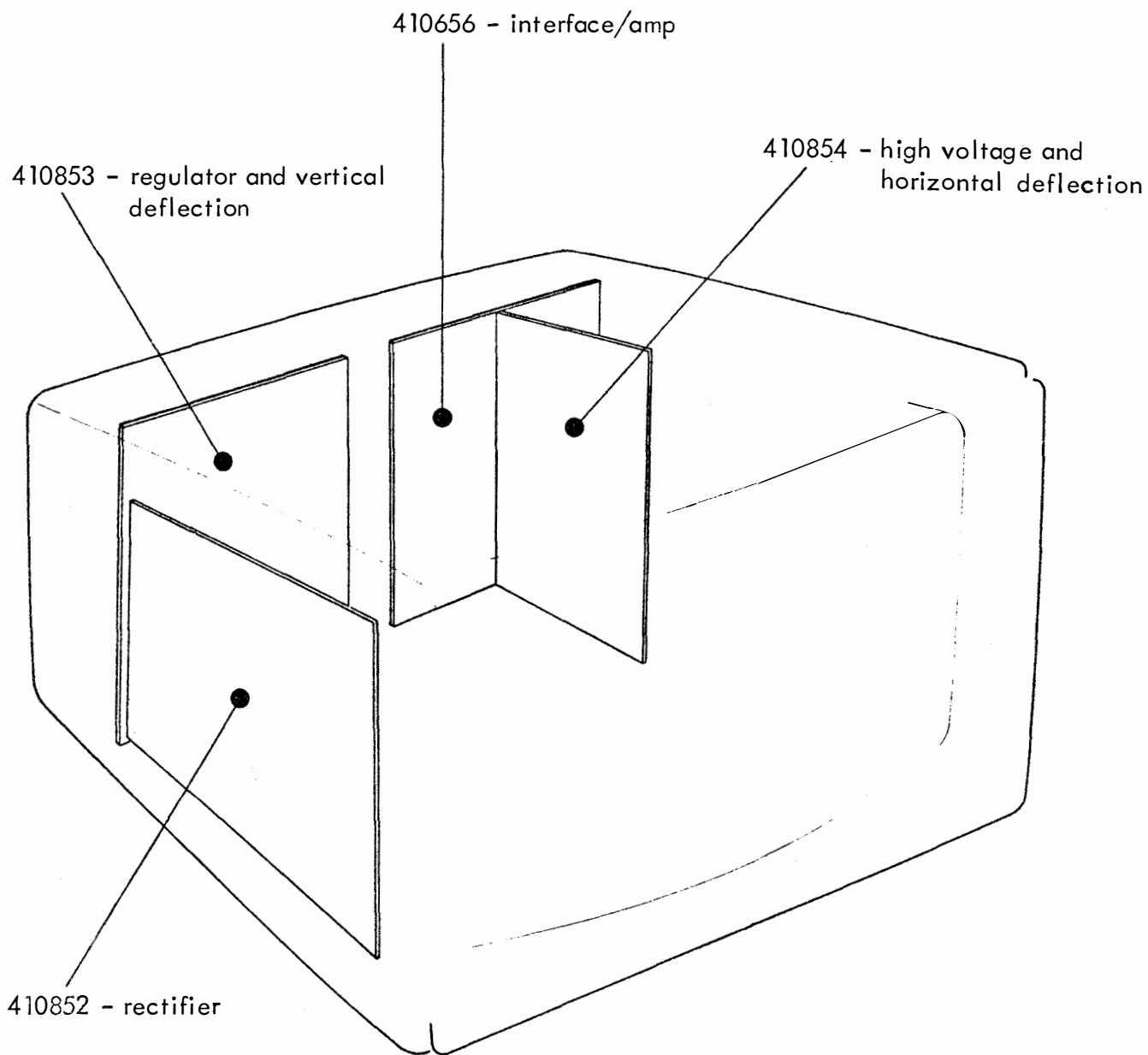

FIGURE 10 - DISPLAY MONITOR CIRCUIT CARDS

E. COMPONENT IDENTIFICATION (Continued)

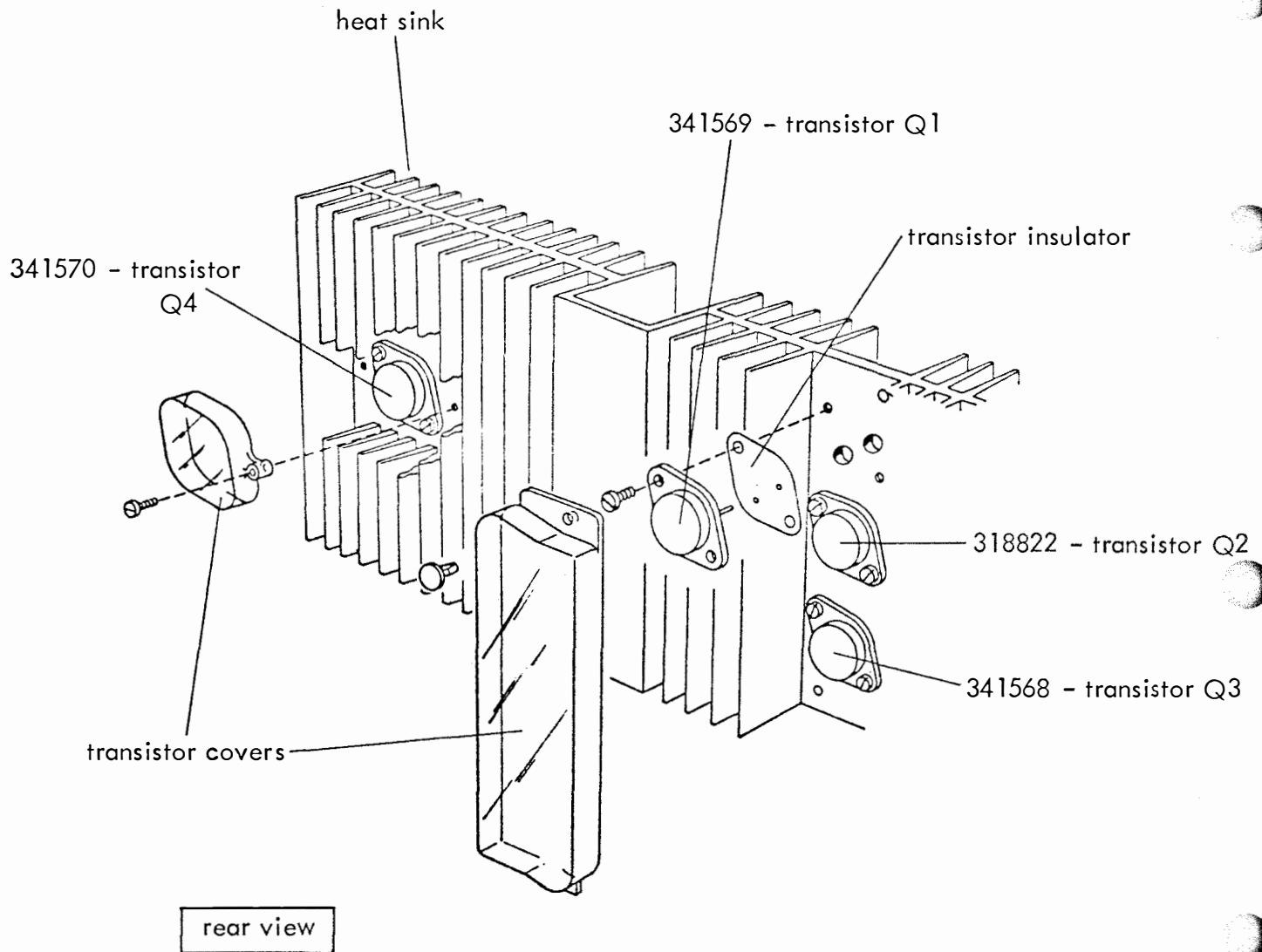

FIGURE 11 - DISPLAY MONITOR TRANSISTORS

E. COMPONENT IDENTIFICATION (Continued)

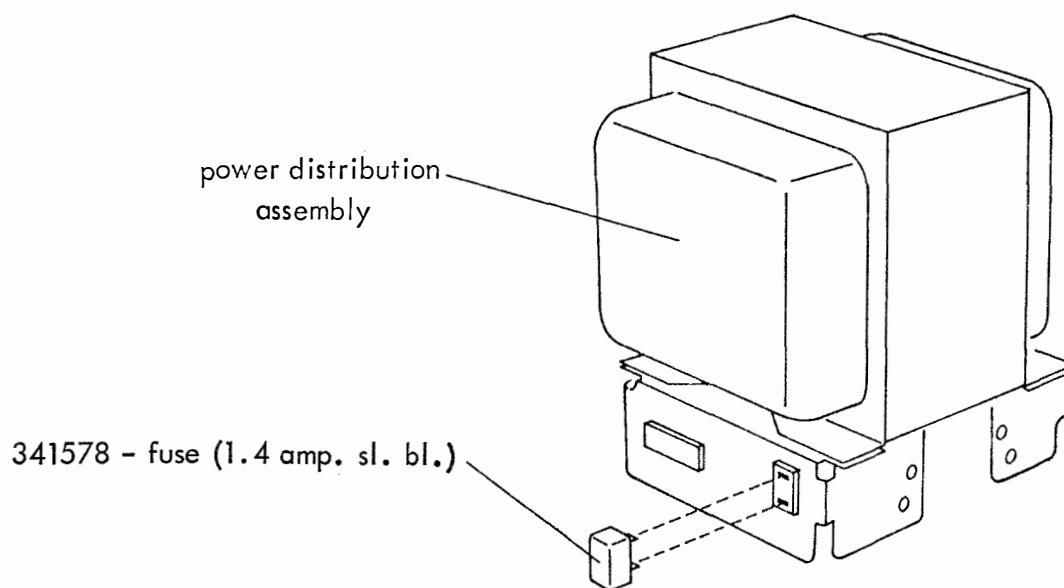

FIGURE 12 - DISPLAY MONITOR FUSE

E. COMPONENT IDENTIFICATION (Continued)

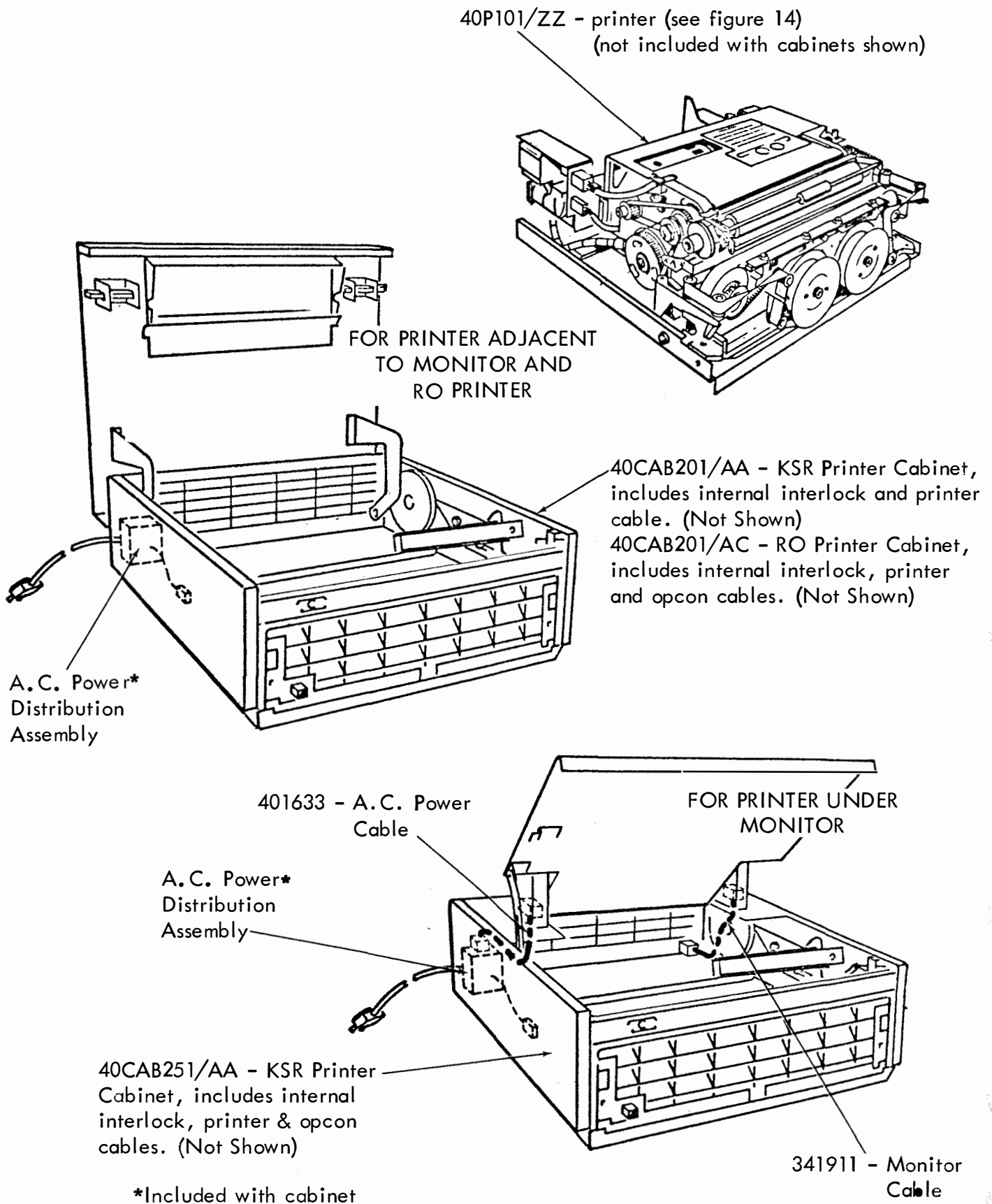

FIGURE 13 - PRINTER PACKAGE

E. COMPONENT IDENTIFICATION (Continued)

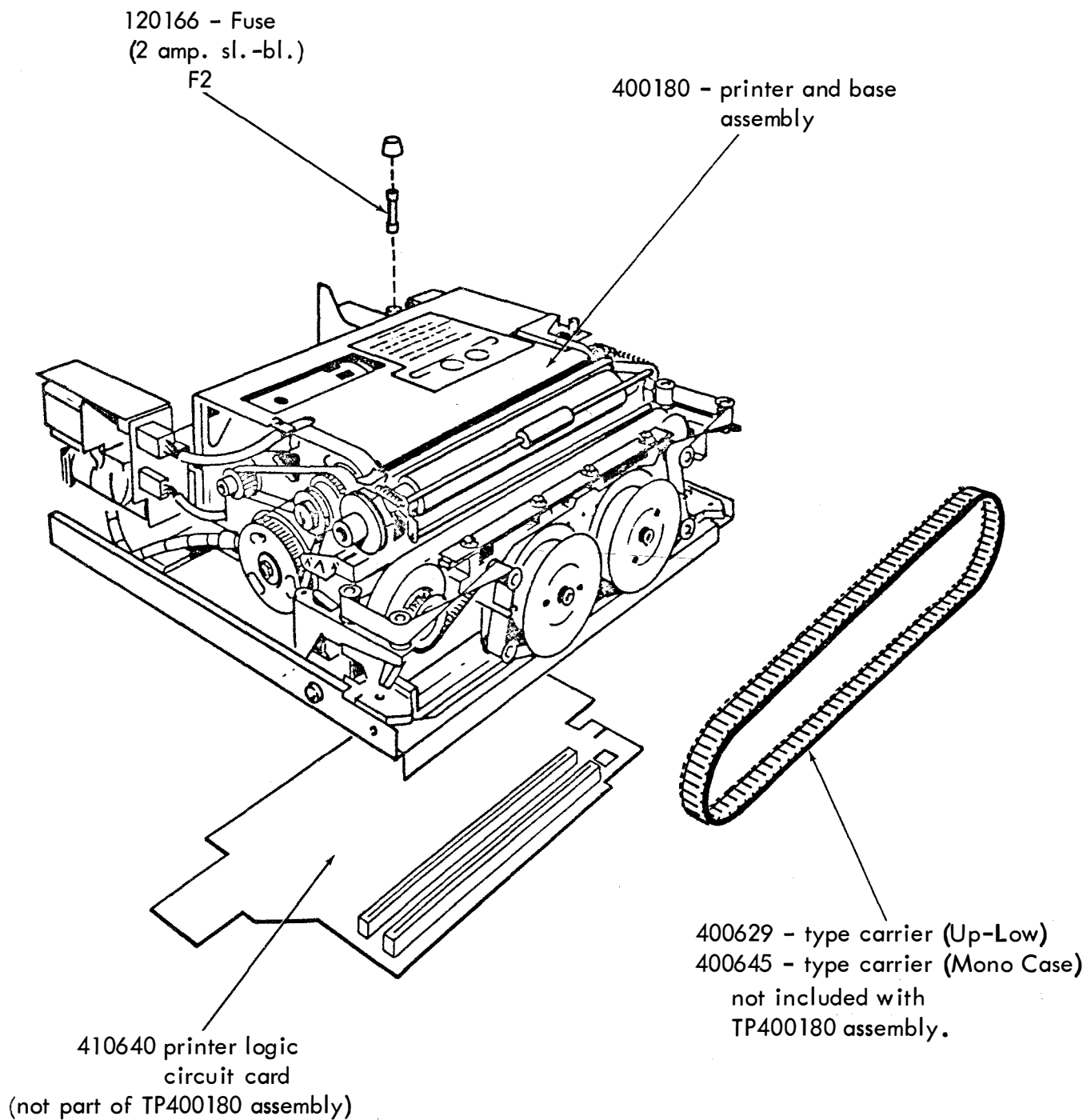

FIGURE 14 - 40P101/ZZ PRINTER COMPONENTS

E. COMPONENT IDENTIFICATION (Continued)

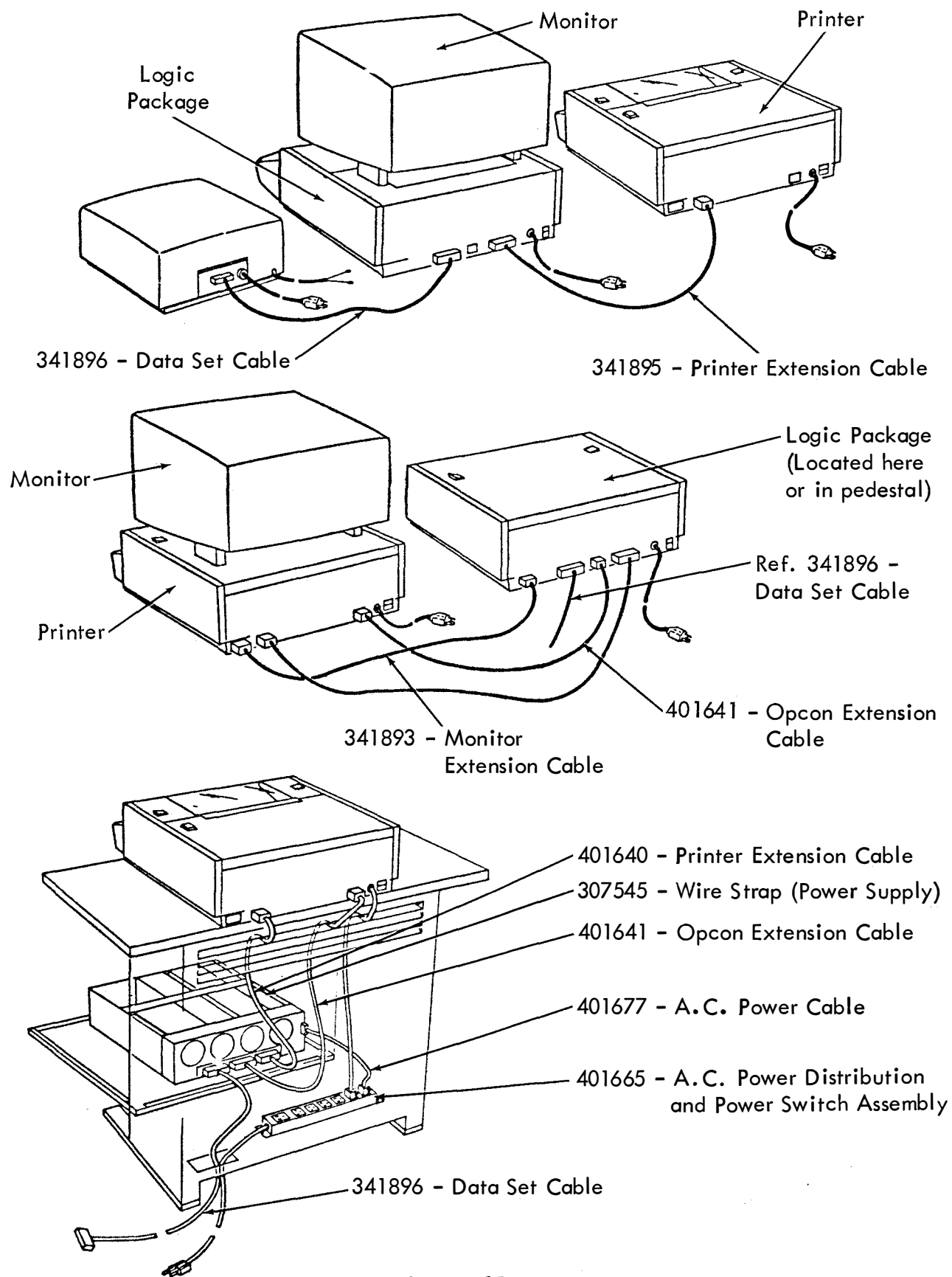

FIGURE 15 - CABLES

E. COMPONENT IDENTIFICATION (Continued)

Numerical listing and page cross reference

Part Number	Description	Page
† 40C103/AE } *Qty 1	Controller (RO) - No storage	130
† 40C103/AD }	Controller (RO) - 1000 Char. Storage	130
† 40CAB201/AA	Printer Cabinet (KSR) - Adjacent to Monitor	138
† 40CAB201/AB	Logic Cabinet (Adjacent to Monitor)	129
† 40CAB201/AC	Printer Cabinet (RO)	138
† 40CAB251/AA	Printer Cabinet (KSR) - Under Monitor	138
40CAB251/AB	Logic Cabinet (Under Monitor)	129
† 40K001/AAA*	Operator Console (RO)	127
40K101/CAK*	Operator Console (KSR)	126
40MN101**	Display Monitor	134
† 40P101/ZZ	Printer w/Circuit Card	138 & 139
40PSU101**	Power Supply	127, 129 & 132
† 120166*	Fuse -2 amp. s1. b1. (F2-Printer)	139
129920*	Fuse -5 amp. s1. b1. (F1-Power Supply)	132
318822*	Transistor (Q2)	136
341568*	Transistor (Q3)	136
341569*	Transistor (Q1)	136
341570*	Transistor (Q4)	136
341578*	Fuse -1 amp. s1. b1. (F3-Monitor)	137
341740	Controller/Display Logic Cable	129
341817	Wired Frame (Display Logic)	131
† 341893	Monitor Extension Cable	140
† 341895	Printer Extension Cable (KSR)	140
† 341896	Data Set Cable	140
† 341907	Wired Frame (Controller)	130
341908	Wired Frame (Controller)	130
† 341909	Wired Frame (Controller)	130
341910*	Carrying Case (Optional)	140b
341911	Monitor Cable	129 & 138
† 400180**	Printer and Base Assembly	139
† 400629*	Type Carrier (Up-Low)	139
† 400645*	Type Carrier (Mono Case)	139
401040**	Fan Assembly	129 & 132
401046**	Fan	132
401048*	Fan Belt	132
401049*	Motor Belt	132
401053**	Motor w/Cable (Fan Assembly)	132
401633	A.C. Power Cable	129 & 138
† 401640	Printer Extension Cable (RO)	140
† 401641	Opcon Extension Cable	140
† 401643	Controller Cable w/Connectors	127
401665	A.C. Power Distribution Assembly (Pedestal)	140
† 401677	A.C. Power Cable (Pedestal)	140
410001*	Processor Circuit Card (Display Logic)	131
410002*	Data Control Circuit Card (Display Logic)	131
410003*	Address Counter Circuit Card (Display Logic)	131

E. COMPONENT IDENTIFICATION (Continued)

Numerical listing and page cross reference

Part Number	Description	Page
410004*	Memory Circuit Card (Display Logic)	131
410005*	Memory Circuit Card (Display Logic)	131
† 410640*	Printer Logic Circuit Card	139
410656*	Interface/Amp Circuit Card (Monitor)	135
410657*	Cache & Char. Gen. Circuit Card (Display Logic)	131
† 410669*	Communications Control Circuit Card (Controller)	130
† 410670*	S/R and PTR Circuit Card (Controller)	130
† 410671*	EIA Interface Circuit Card (Controller)	130
410672*	Opcon Circuit Card (Controller)	130
410674*	Data Bus & Decode Circuit Card (Controller)	130
410675*	Message Control Circuit Card (Controller)	130
410676*	Send Variations Circuit Card (Controller)	130
†† 410677*	PTI Interface Circuit Card (Controller)	130
†† 410678*	Ext. Mode Control Circuit Card (Controller)	130
410852*	Rectifier Circuit Card (Monitor)	135
410853*	Reg. & Vert. Deflection Circuit Card (Monitor)	135
410854*	High Voltage & Horiz. Defl. Circuit Card (Monitor)	135
410855*	Video Generator Circuit Card (Display Logic)	131

*These parts may be stocked at location where there are a large number of terminals or carried to the terminal in the optional carrying case shown. The case will hold a complete set of maintenance parts excluding the Operator Console.

**These components are stocked in central locations.

Items without asterisks are not stocked in the field and must be obtained from a service center.

† Not used in PTI sets.

†† Not used in EIA sets.

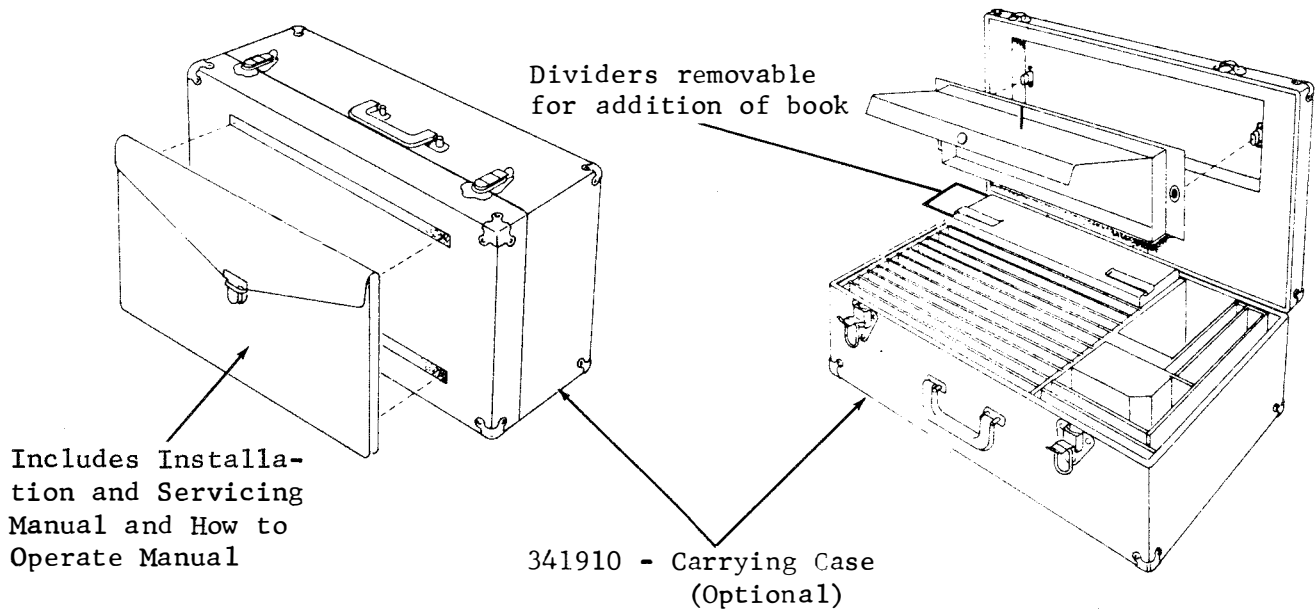

F. COMPONENT ACCESS



F. COMPONENT ACCESS

CAUTION: REMOVE ALL POWER FROM THE SET BEFORE PERFORMING ANY COMPONENT REPLACEMENT OR CONVERSIONS. THIS DOES NOT APPLY TO COVER REMOVAL FOR ACCESS TO TEST SWITCHES, OR TO POWER ON ADJUSTMENTS OF THE MONITOR. FOR SET POWER SWITCH LOCATIONS REFER TO GENERAL INFORMATION OF PART C.

1. Component Replacement

a. Monitor

- (1) Removal of entire Monitor Unit from the set:

Grasp the Monitor by the sides near the supports and simply lift up. Electrical cable connectors are part of the support assembly (Figure 1).

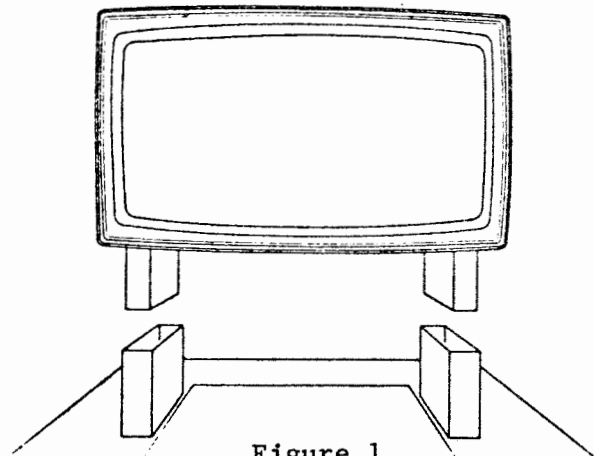

Figure 1

- (2) Removal of Monitor Housing:

Tilt the monitor back and disengage latch (Figure 2). Slide the housing back partially. Position the Monitor to its normal position making sure it locks in that position (Figure 3). Remove housing completely.

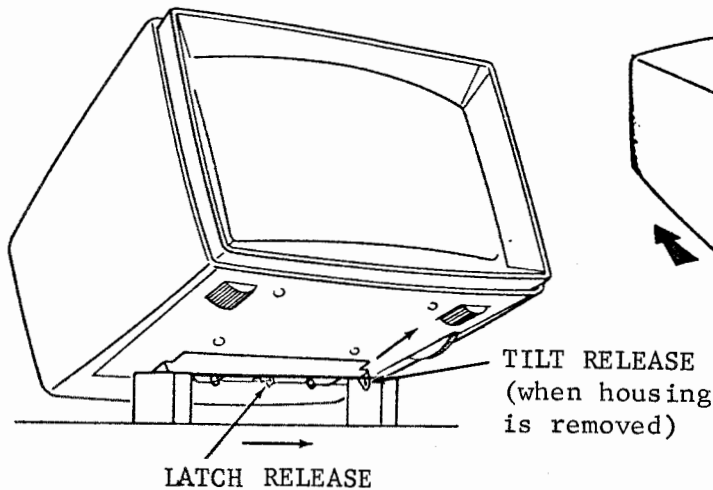

Figure 2

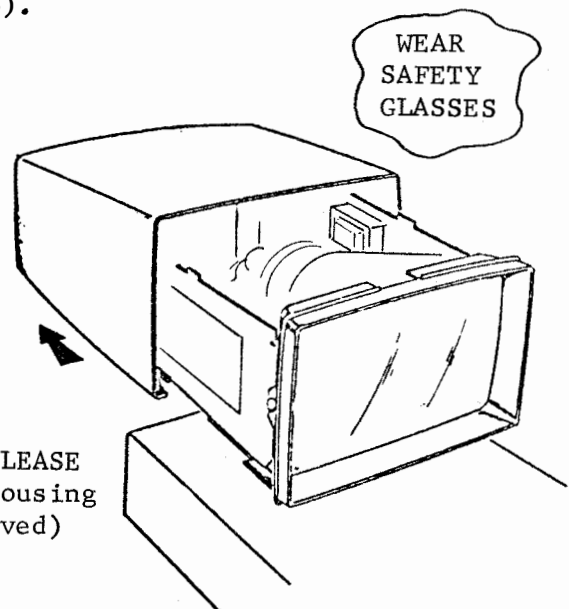

Figure 3

F. COMPONENT ACCESS (Continued)

1. Component Replacement (Continued)

a. Monitor (Continued)

(3) Circuit Card removal and installation:

- Follow steps for removal of individual cards in the order specified. Reverse the order to install
- Stud mounted cards - Collapse pin and pry off to remove, push on to install (Figure 6).
- Release the two captive screws on the heat sink assembly (1/4 turn left) and pivot the heat sink assembly back for easier access to its cards.

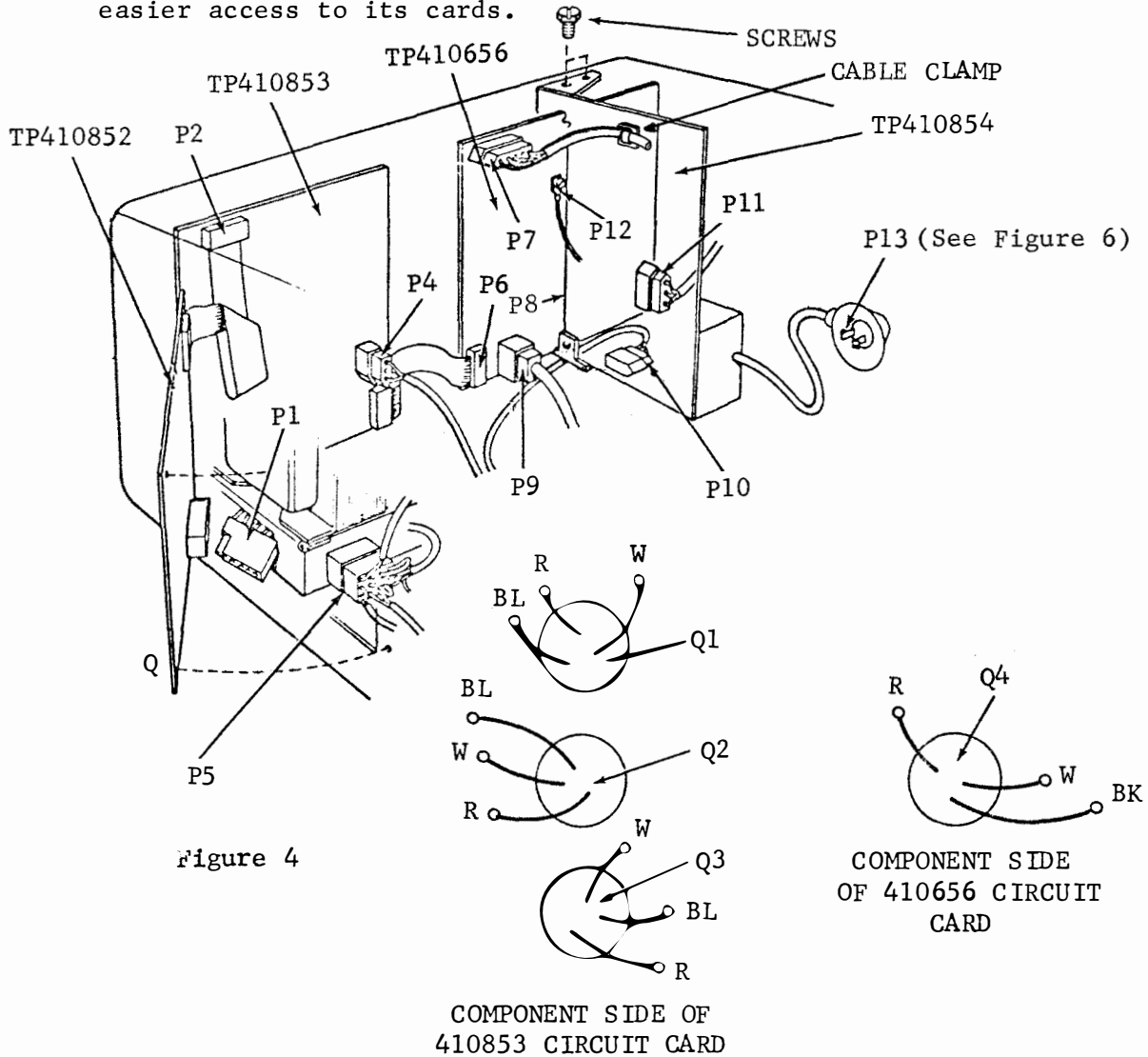

Figure 4

TP410852 - Remove P2, Card, P1.

TP410853 - Remove P2, P6*, P4, 9 transistor push on terminals from card, card.

TP410854 - Remove P13, P10, P7 cable from clamp, 2 screws, card (brackets are part of card) (P8).

TP410656 - Remove 410854, P7, P12 (ring terminal - screw must be removed entirely), P6*, P9, P11.

*It will be easier to grasp if neck of tube is rotated upward using tube tilt wheel. Also note manner in which cable is dressed behind heat sink (reinstall in same manner).

F. COMPONENT ACCESS (Continued)

1. Component Replacement (Continued)

a. Monitor (Continued)

(4) Transistor removal and installation:

Remove plastic covers
(pry off nylon rivet, or
remove screw).

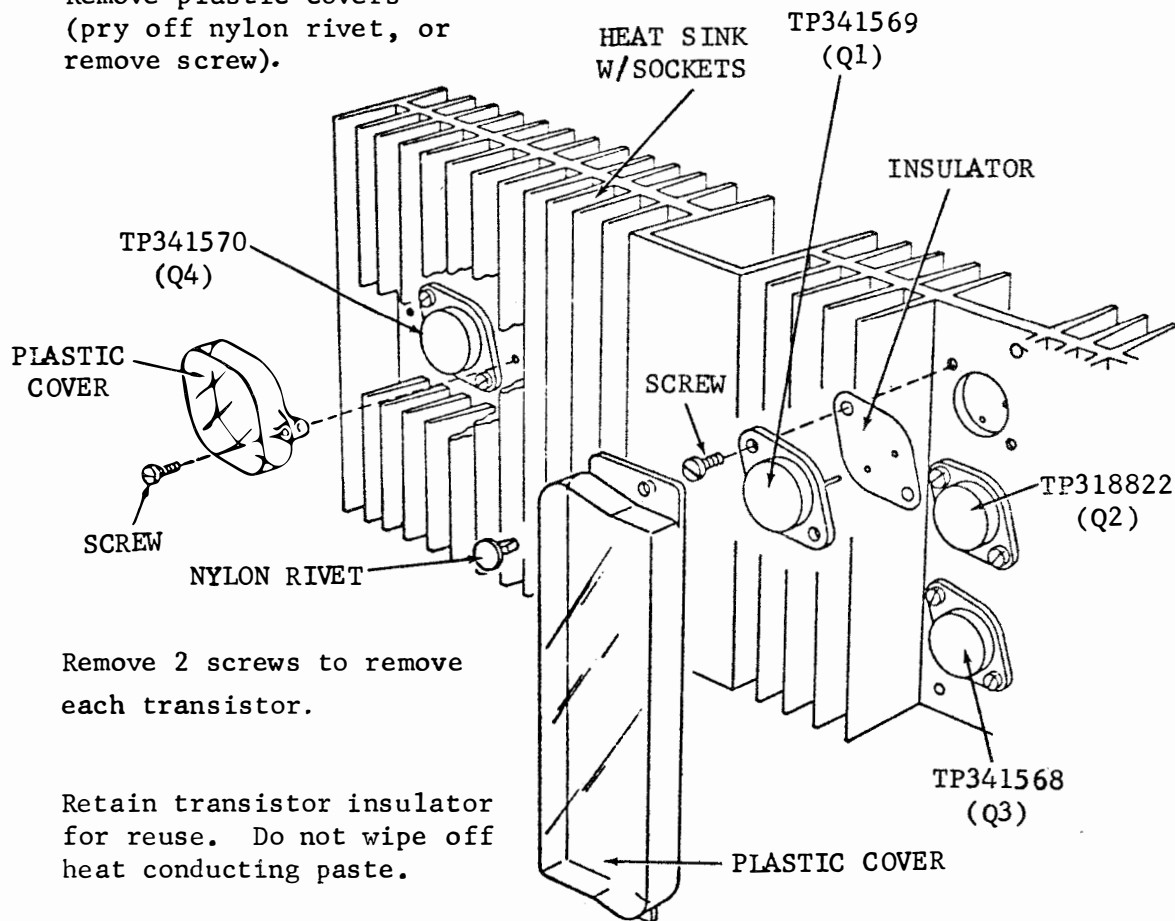

Remove 2 screws to remove
each transistor.

Retain transistor insulator
for reuse. Do not wipe off
heat conducting paste.

(5) Omitted in this issue.

Figure 5

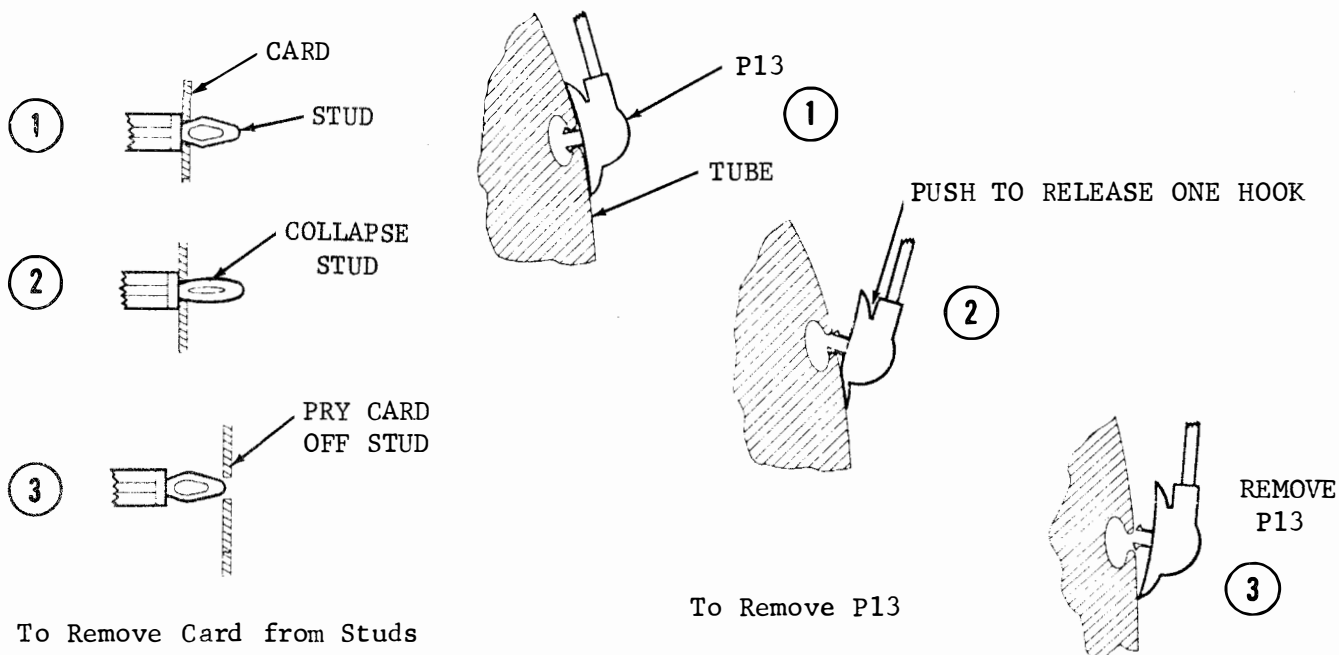

To Remove Card from Studs

To Remove P13

Figure 6

- F. COMPONENT ACCESS (Continued)
- 1. Component Replacement (Continued)
 - a. Monitor (Continued)
 - (5) Omitted in this issue.

- (6) TP341578 Fuse replacement:
 - Pull out - push in (Figure 8).

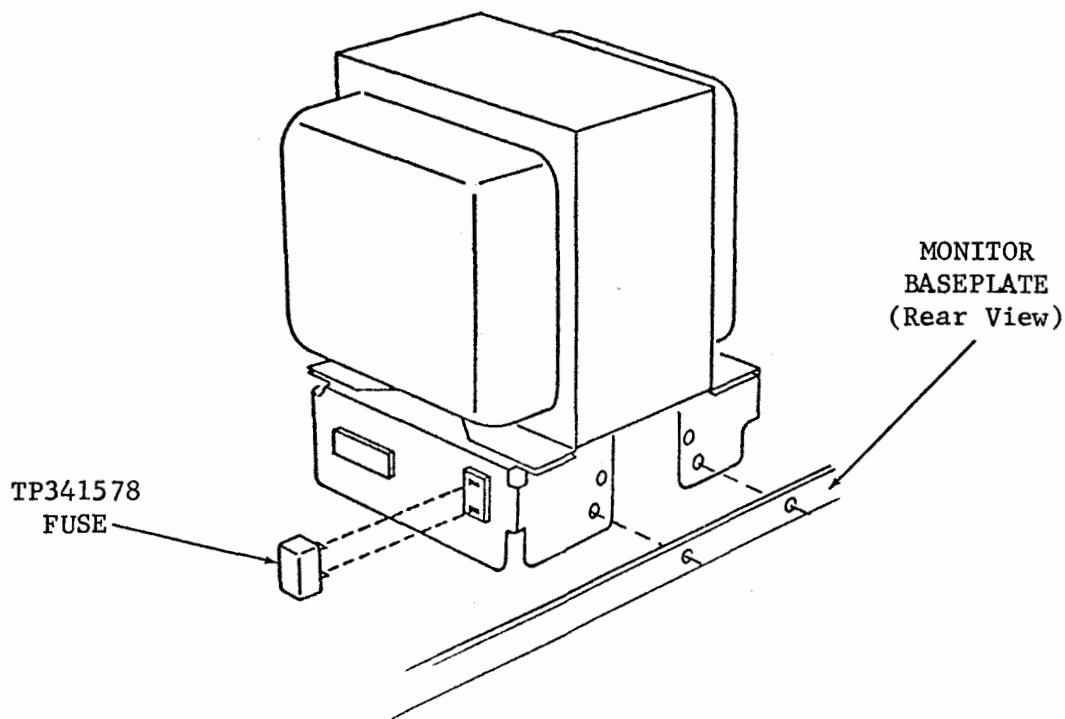

F. COMPONENT ACCESS (Continued)

1. Component Replacement (Continued)

b. Electronic Package

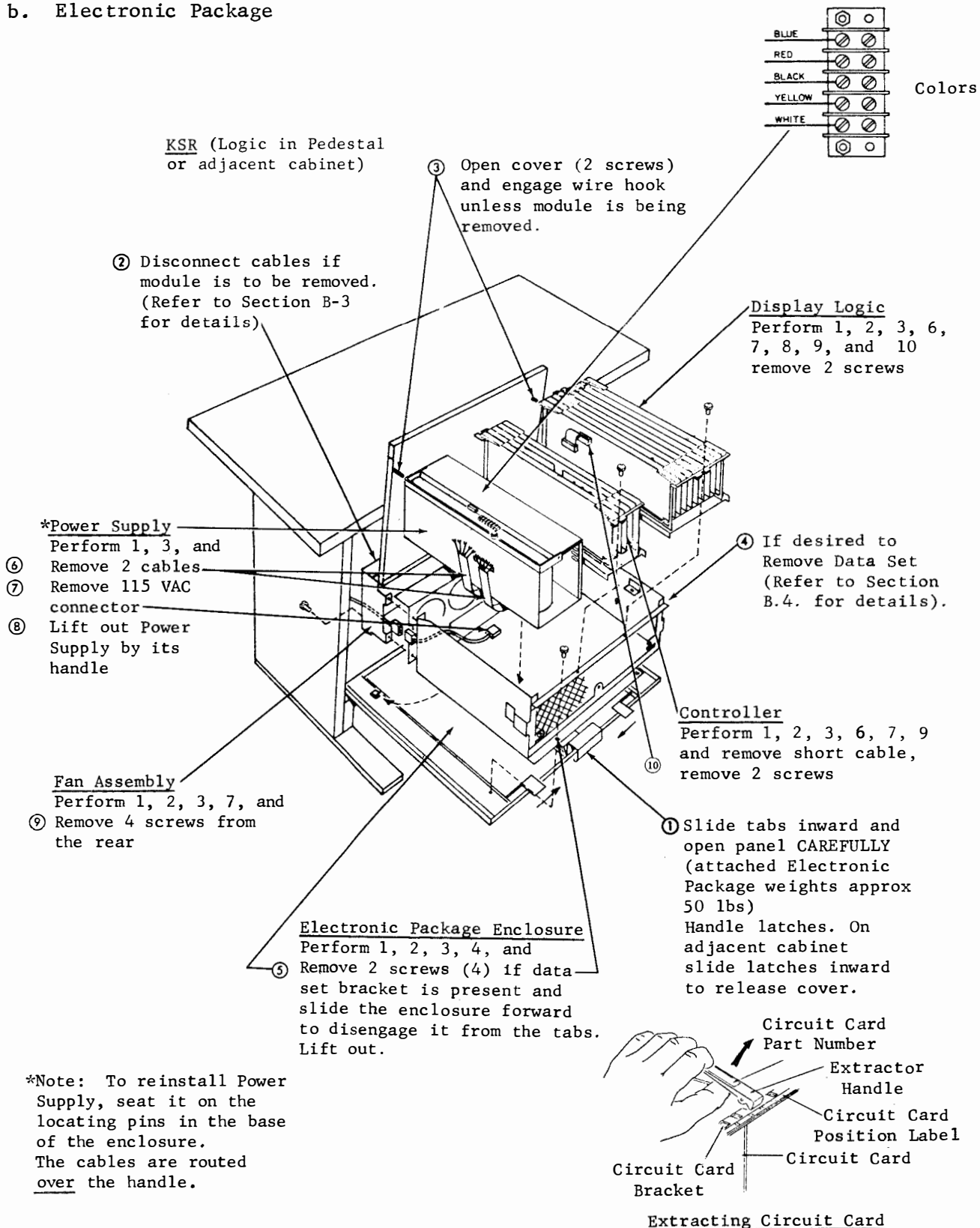

*Note: To reinstall Power Supply, seat it on the locating pins in the base of the enclosure. The cables are routed over the handle.

F. COMPONENT ACCESS (Continued)

1. Replacement (Continued)

b. Electronic Package

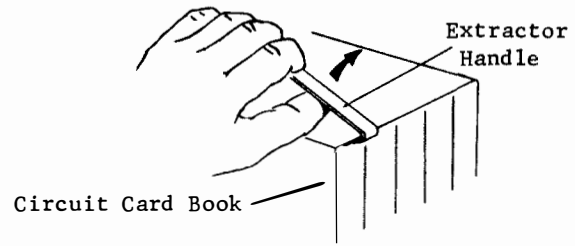

Extracting Circuit Card Book

RO

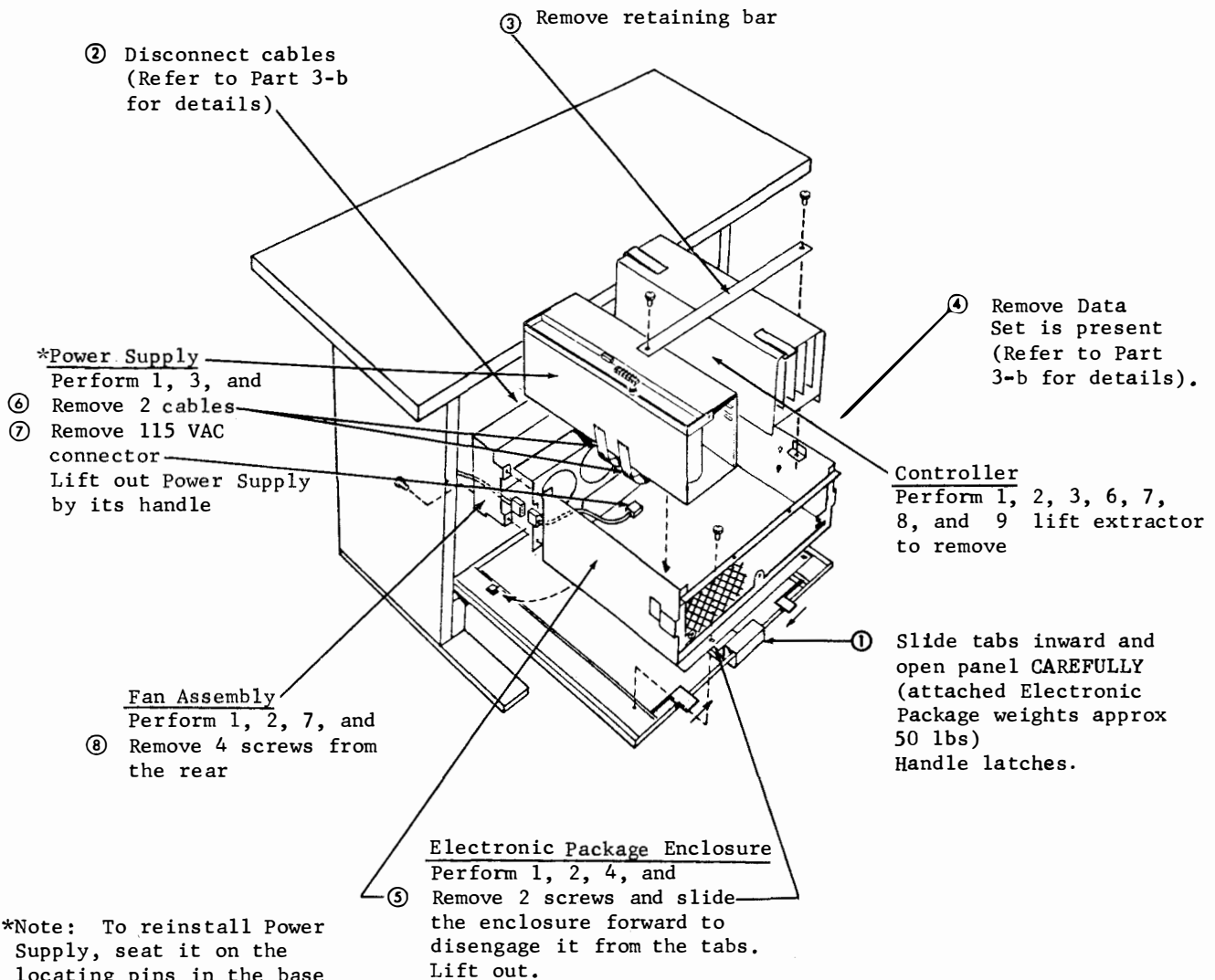

F. COMPONENT ACCESS (Continued)

1. Component Replacement (Continued)

b. Electronics Package (Continued)

KSR (Logic Under Monitor) (Continued)

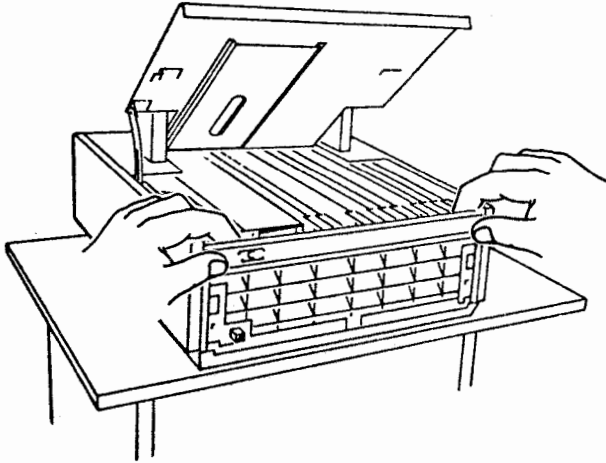

To remove cards or power supply:

- ① Open lid
- ② Insert fingers as shown and lift then pull module forward

Note: Do not attempt to lift at OPCON (if Present)

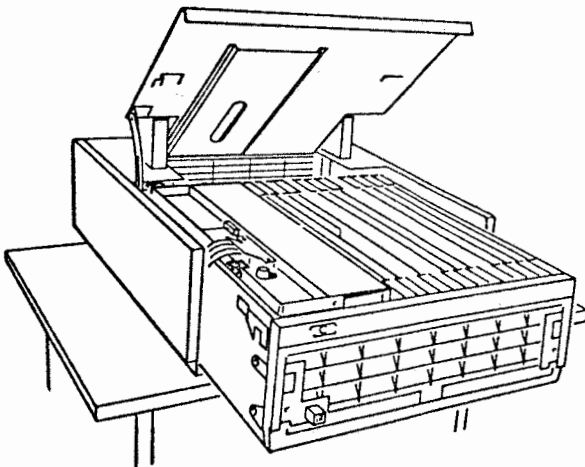

- ③ Move module forward until blocked by latch to provide sufficient clearance for card removal.

Continued on next page.



- F. COMPONENT ACCESS (Continued)
- 1. Component Replacement (Continued)
 - b. Electronic Package (Continued)
 - KSR (Logic Under Monitor)

After sliding out module
See Page 146A.

To remove circuit cards:

- ① Lift handle(s) carefully and
- ② Remove circuit card

To remove and replace Power Supply:

- ① Disconnect AC power cord.
- ② Remove Insulator
- ③ Remove 4 rear screws and loosen front screw. Remove cable and wires from terminal strip.
- ④ Loosen screw sufficient to raise and turn retaining bracket away from handle.

⑤ Use handle to lift out power supply.

⑥ Replace power supply making sure to seat on locating pins.

⑦ Replace wires and just start screws. Then slip in Cable terminals and tighten screws.

⑧ Replace insulator and plug in AC power cord and reposition return bracket.

To Remove and Replace Module for Access to fans and units:
(See Page 145)

- ① Remove Opcon (If present) See Page 150.
- ② Insert screwdriver under latch and lift up on latch. Slide module slightly forward.
- ③ Reach in and disconnect AC Power Cord.
- ④ Lift Out Module

⑤ Replace module by sliding it in part way. Then connect AC power cord and place magnet against side of cabinet. Slide in fully making sure cable folds properly.

⑥ Make sure module is fully seated to the rear and seats fully down.



F. COMPONENT ACCESS (Continued)

1. Component Replacement (Continued)

C. Printer

Removal and replacement of the entire printer assembly

Note: The circuit card can be removed after Step 4 of disassembly. See next page. If printer is not being removed omit Steps 2 & 3.

- ① Open cover
- ② Disconnect the INTERLOCK cable connector
- ③ Remove paper roll

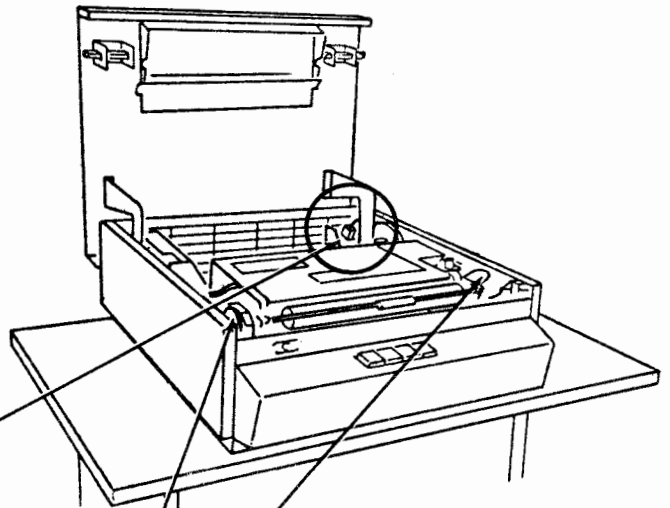

Printer Slide
Detent

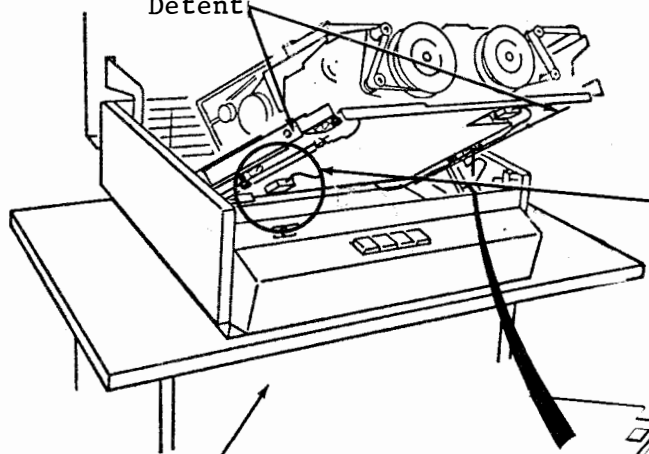

- ④ Release printer to the tilt position by depressing the left and right release levers.
- ⑤ Disconnect the 115 VAC connector.
- ⑥ Disconnect SSI Cable from printer cable.

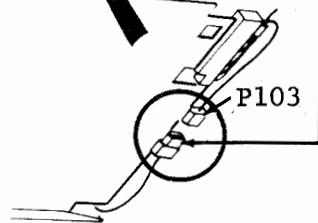

- ⑦ Release (push in) the printer slide detents and pull the printer out by grasping it by the frame (front bottom).
- ⑧ Reverse the order to install the printer or see Section B.3.
- ⑨ To remove printer cabinet from pedestal disconnect 2 cables and withdraw AC power cord from pedestal after unplugging from convenience receptacle. (See section B.3. for replacement.)

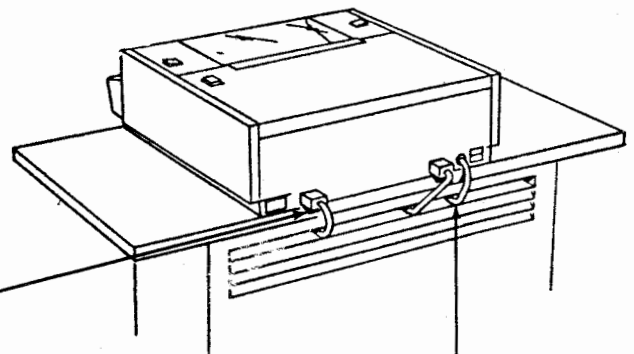

AC Power
Cord

F. COMPONENT ACCESS (Continued)

1. Component Replacement (Continued)

C. Printer (Continued)

Removal of TP410640 Circuit Card Assembly (Figure 1):

- ① With the printer in the "ribbon changing position" (refer to the note on page 147), remove 2 screws that secure the paper chute to the bottom of the printer and allow the chute to hinge down.
- ② Disconnect printer P103 cable connector from the SSI connector.
- ③ Using finger hold and a firm grip of the card edge on the opposite side as shown, use an even pulling force and unplug the TP410640 card from the two rows of magnet assembly contacts.
- ④ Carefully lift the bottom edge of the card out from the metal channel and unplug the J102 connector from the edge contacts of the card. Remove card.

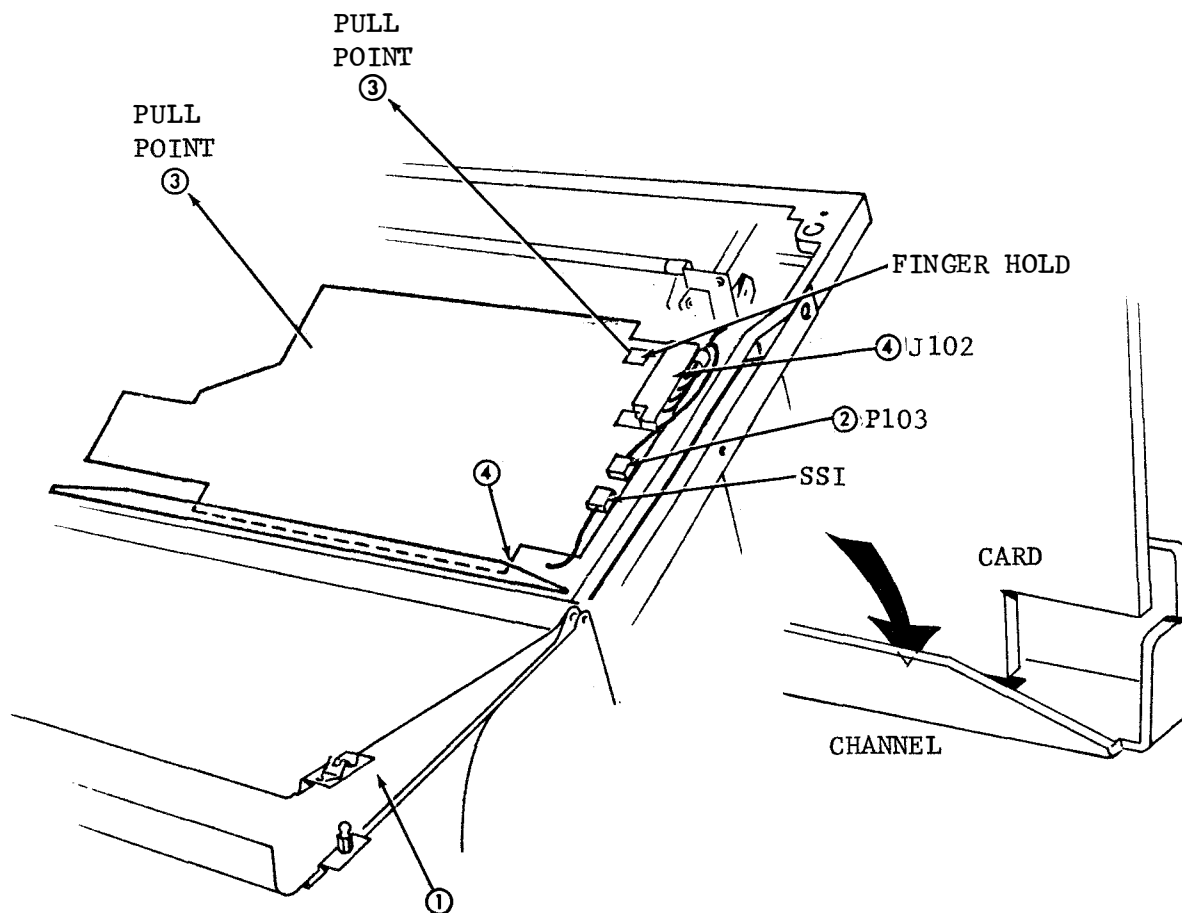

Note: During reassembly, make certain that the J102 connector is plugged onto the card and that the card is located within the channel before plugging it into the two rows of magnet assembly contacts. Apply slight pressure at both ends and middle of card to fully seat it on magnet contacts.

F. COMPONENT ACCESS (Continued)

1. Component Replacement (Continued)

c. Printer (Continued)

Removal of TP400645 Monocase or TP400629 Up low Type Carrier Assembly:

- ① With printer in the "ribbon changing position" (see note on page 147) remove the ribbon. The spools snap in and out.
- ② Depress the left ribbon guide release tab to allow it to spring open.
- ③ Loosen thumb screw on the right ribbon guide bracket and position it to the right.
- ④ Lift up the arm on the left type carrier pulley to release the spring bias on the pulley. While holding the arm up, lift the type carrier off the pulley. Carefully guide the type carrier out toward the front.

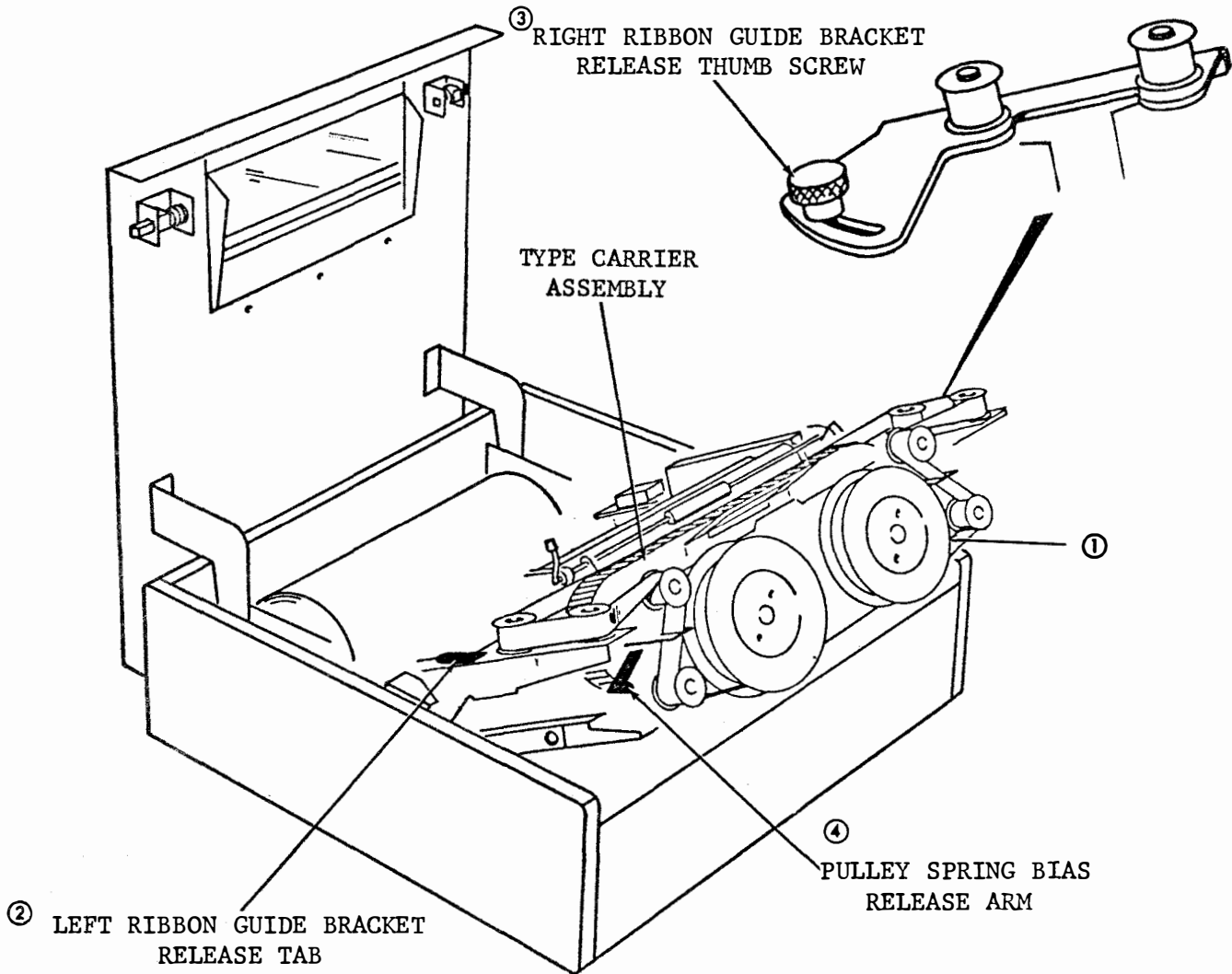

Figure 3

F. COMPONENT ACCESS (Continued)

1. Component Replacement (Continued)

d. Operator Console

Place thumb on inward tab of console - both sides
Press downward into unlatched position - each side.
Remove console.

(When replacing console, make sure locating pins are
fully engaged before pushing latch levers upward
into locked position.)

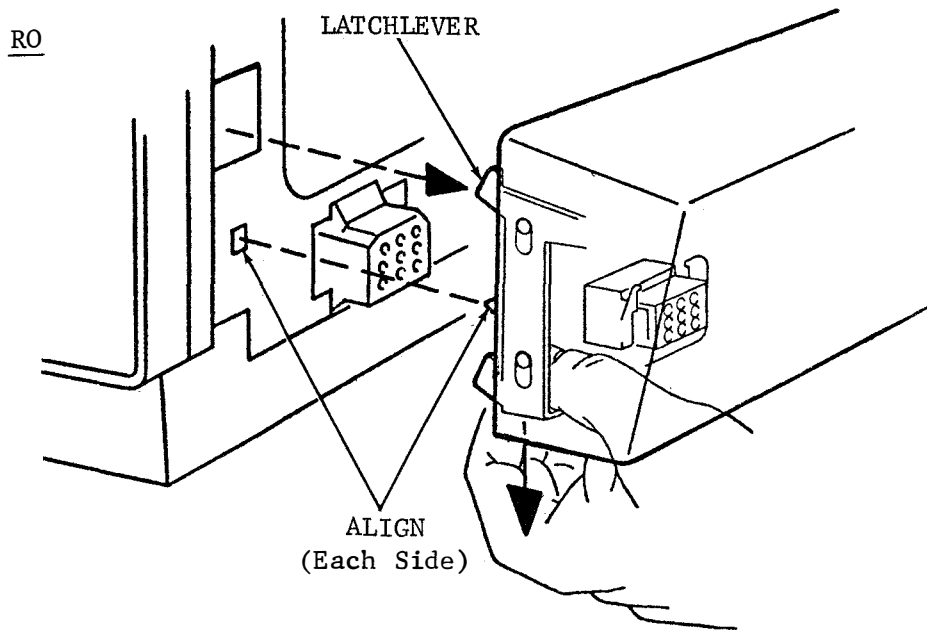
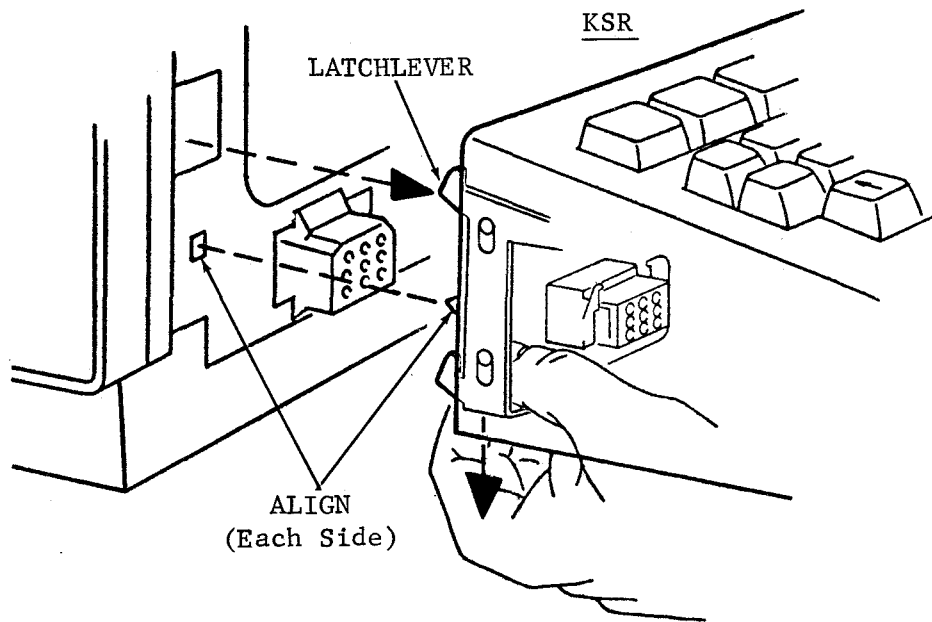

F. COMPONENT ACCESS (Continued)

1. Component Replacement (Continued)

d. Operator Console (Continued)

Omitted in this issue

F. COMPONENT ACCESS (Continued)

1. Component Replacement (Continued)

d. Operator Console (Continued)

● Removal or Installation of Keytops

CAUTION: LOCKING KEYSWITCHES (ie, "CAPS LOCK") MUST BE IN UNLATCHED UP POSITION BEFORE REMOVING KEYTOP OR PERMANENT SWITCH DAMAGE WILL RESULT.

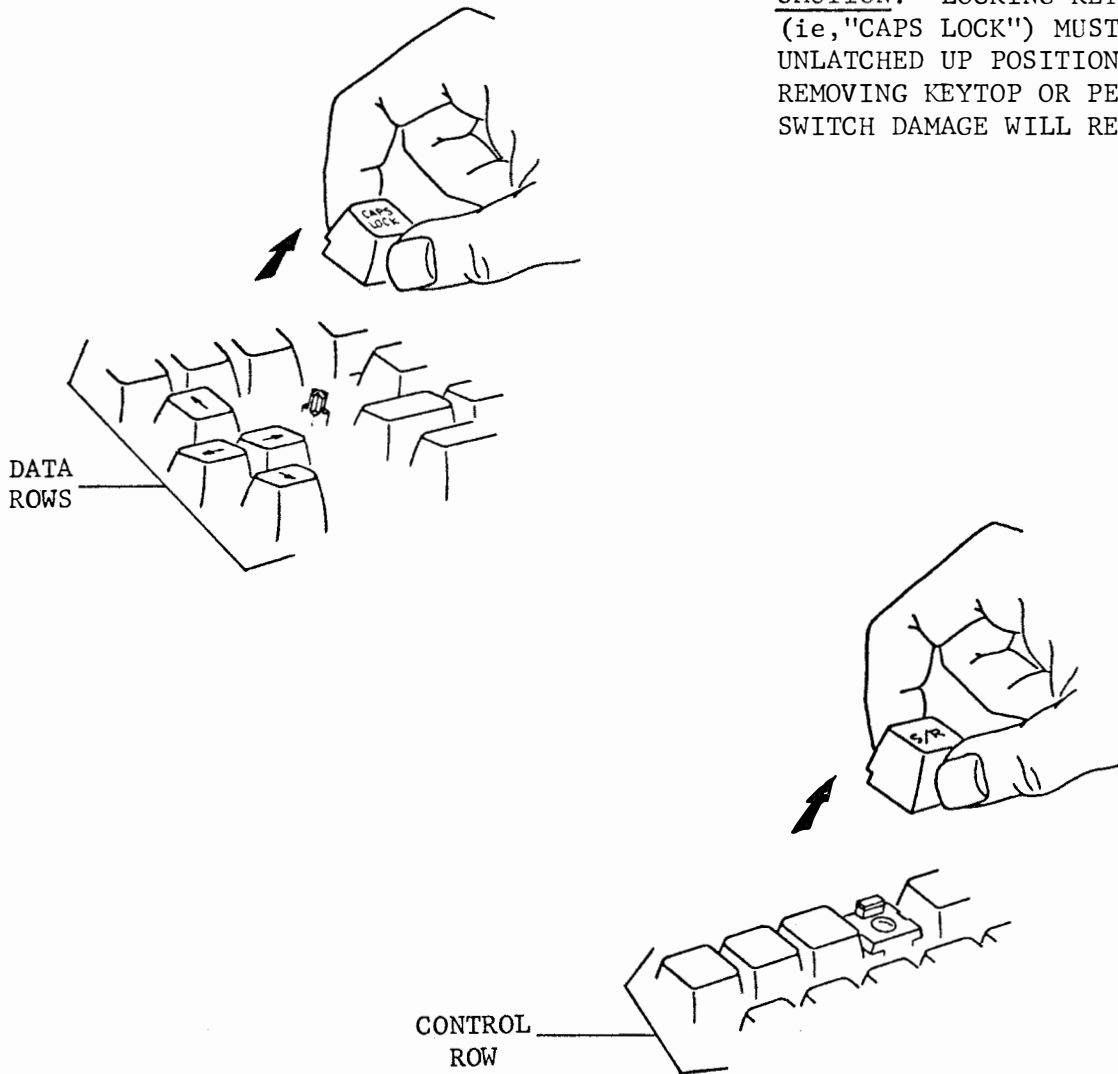

- Grasp keytop at a convenient location using thumb and index finger and exert upward force until keytop releases. If necessary, remove surrounding keytops that block access to keytop requiring removal.

To replace keytop, just reverse removal instruction.

F. COMPONENT ACCESS (Continued)

1. Component Replacement (Continued)

d. Operator Console (Continued)

● Installing or Removal
of Blocking Type Keytop

Hold blocking type keytop with least curved side of the cap toward the rear of console. Operate switch to either desired position - in control row, on or off - in data rows, latched (down) or unlatched (up) unoperated if keytop is locking type. Position cap over switch housing until ridges in keytop are retained by grooves in switch body.

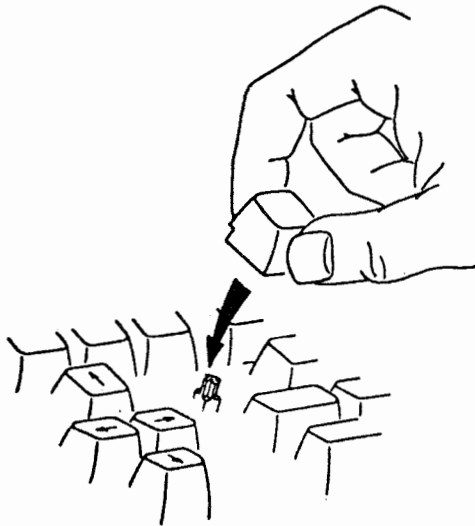

● To remove blocking keytop, exert upward force until ridges on keytop release from switch housing.

F. COMPONENT ACCESS (Continued)

1. Component Replacement (Continued)

d. Operator Console (Continued)

Omitted in this issue

F. COMPONENT ACCESS (Continued)

3. Conversions (Continued)

a. Electronic Package (Continued)

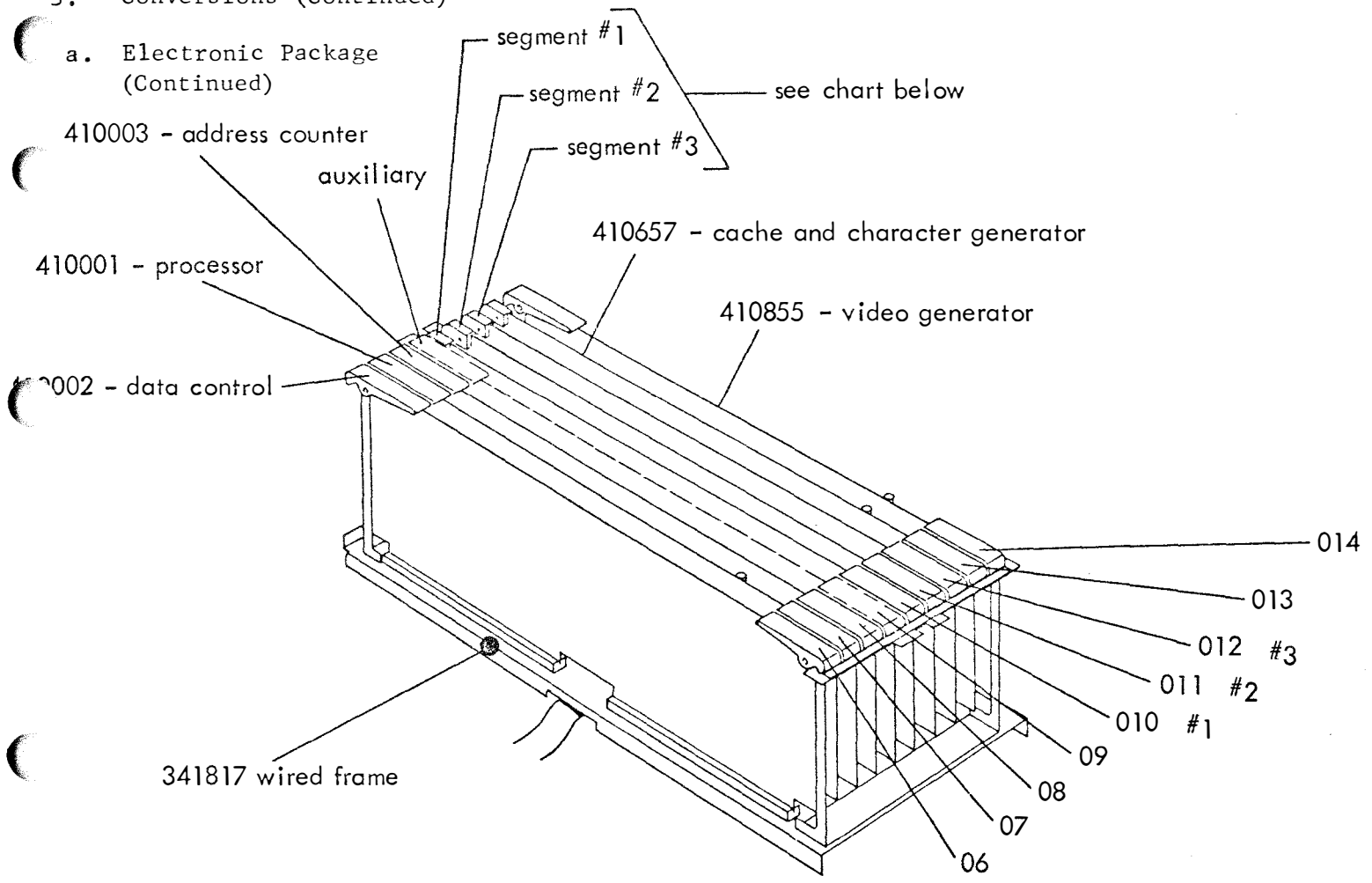

display logic arrangements			
memory segment	full edit 24 line	full edit 48 line	full edit 72 line
#1	410005	410005	410005
#2	none	410005	410005
#3	none	none	410005

segment storage for 10 data bits, highlight, protected format and tab.

Note:

On sets without full editing features, the 410005 circuit card is replaced by the 410004 circuit card with segment storage for 7 data bits.

F. COMPONENT ACCESS (Continued)

3. Conversions (Continued)

b. Operator Console

If an Operator Console should ever malfunction, it can be replaced by the "maintenance spare" console even if the spare has a different keytop arrangement. Using the simple steps in the following routine as a guide, keytops can be removed from the defective console, interchanged with, and installed onto the maintenance spare.

The following illustration of the Operator Console is provided for reference. To install or remove keytops and/or blocking keytops, refer to the following instructions and section F. 1. d.

F. COMPONENT ACCESS (Continued)

3. Conversion (Continued)

b. Operator Console

KEYBOARD CONVERSION REFERENCE

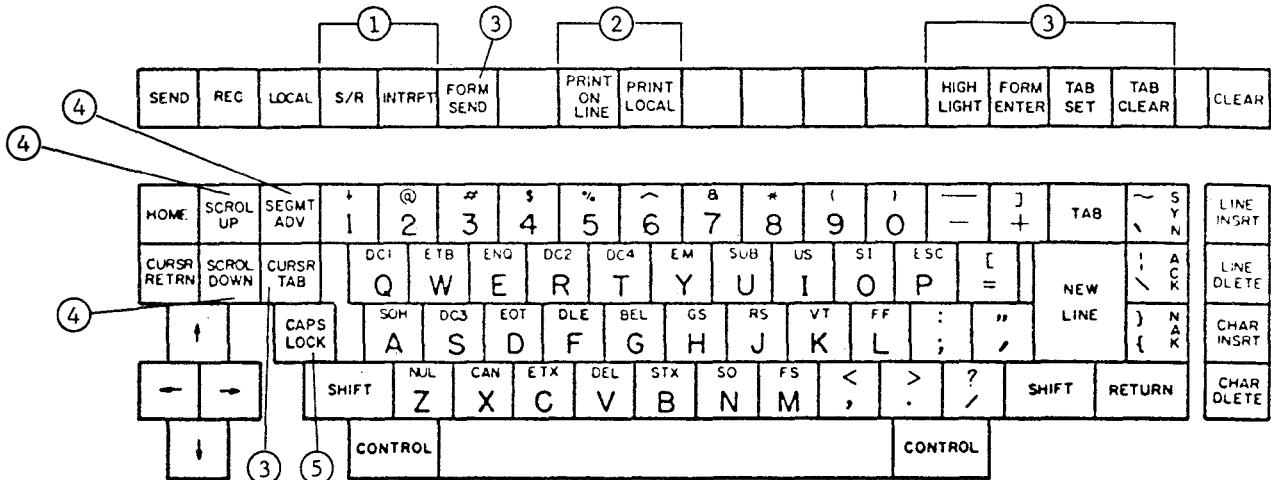

- ① Keytops present for S/R (conversation mode). See note.
- ② Keytops present when terminal is equipped with page printer. See note.
- ③ Keytops are present only if terminal has full edit feature. See note.
- ④ Keytops present only if terminal has 48 or 72 line display memory. See note.
- ⑤ If CAPS LOCK keytop is not present, keyswitch plunger is latched (down) for monospace - all caps - operation; blocking type keytop is installed over switch housing. First depression latches keyswitch down; second depression unlatches keyswitch (up).

CAUTION: IF KEYTOP IS PRESENT AND REMOVAL IS REQUIRED, DO NOT REMOVE KEYTOP FROM SWITCH SHAFT UNLESS SWITCH PLUNGER IS OPERATED INTO UNLATCHED-UP-POSITION.

Note: If keytop is not provided within console arrangement, a blocking type keytop (unmarked) is installed over housing of keyswitch. Keytops are not present under blocking cap.



G. ADJUSTMENTS

G. ADJUSTMENTS

1. Electrical

The only electrical adjustments associated with the Model 40 sets are contained in the Monitor Unit. These adjustments, listed below, are keyed to the Brief CheckOut Procedure in Section C, and should be performed only as prescribed therein.

CAUTION: The adjustments listed below will be made with the housing removed, and the power on. Observe all precautionary instructions to avoid accidental electrical shock or breakage of the cathode ray tube.

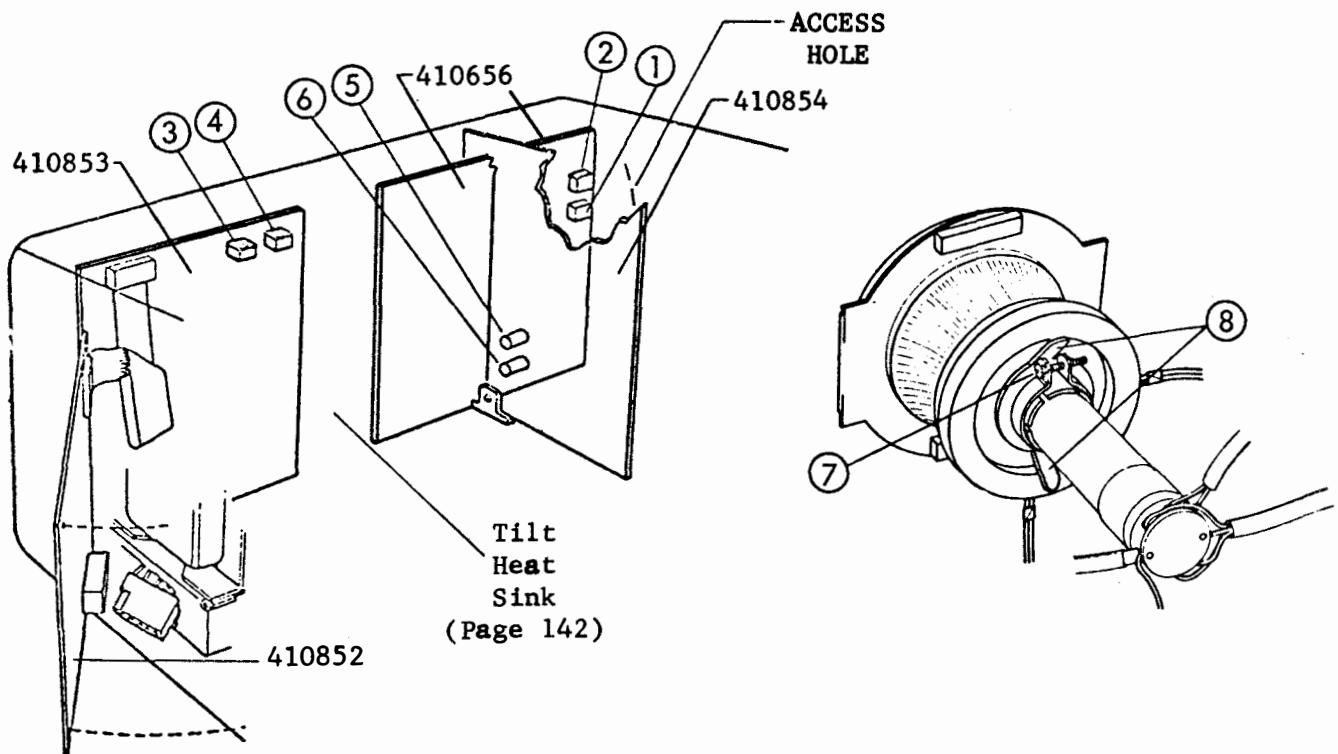

- | | | |
|---|----------------------|---------------------|
| ① | Master Brightness | - Par. 1.1 Page 161 |
| ② | Focus | - Par. 1.2 Page 161 |
| ③ | Vertical Size | - Par. 1.3 Page 162 |
| ④ | Vertical Linearity | - Par. 1.4 Page 162 |
| ⑤ | Horizontal Size | - Par. 1.5 Page 163 |
| ⑥ | Horizontal Linearity | - Par. 1.6 Page 163 |
| ⑦ | Yoke Orientation | - Par. 1.7 Page 164 |
| ⑧ | Display Centering | - Par. 1.8 Page 164 |

G. ADJUSTMENTS (Continued)

1. Electrical (Continued)

● MASTER BRIGHTNESS

Potentiometer located on 410656 Circuit Card used in conjunction with the operator brightness control to adjust the range and limit the maximum brightness of the display.

Requirement: With the Operator Brightness control turned all the way to the left, all display should disappear, and when turned all the way to the right the raster should be just visible.

To Adjust: Turn Operator Brightness control all the way to the right, then adjust Master Brightness potentiometer so that the raster just appears.

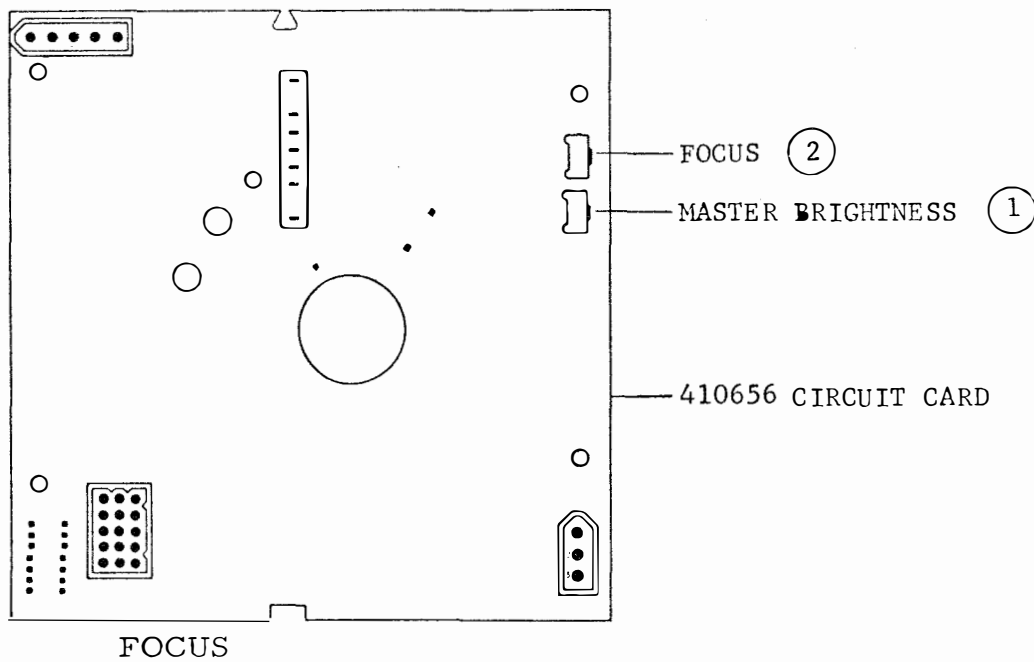

Potentiometer located on 410656 Circuit Card to adjust the overall focus of the display. With characters displayed, adjust the potentiometer to obtain optimum sharpness of the display.

NOTE: Circled numbers on illustrations show order of adjustment.

G. ADJUSTMENTS (Continued)

1. Electrical (Continued)

● VERTICAL SIZE

Potentiometer located on 410853 circuit card adjusts the vertical height of the display.

Requirement: $5 \frac{1}{4}'' \pm \frac{1}{8}''$

To Measure: Fill the left column of the display area with E's (24 Lines)

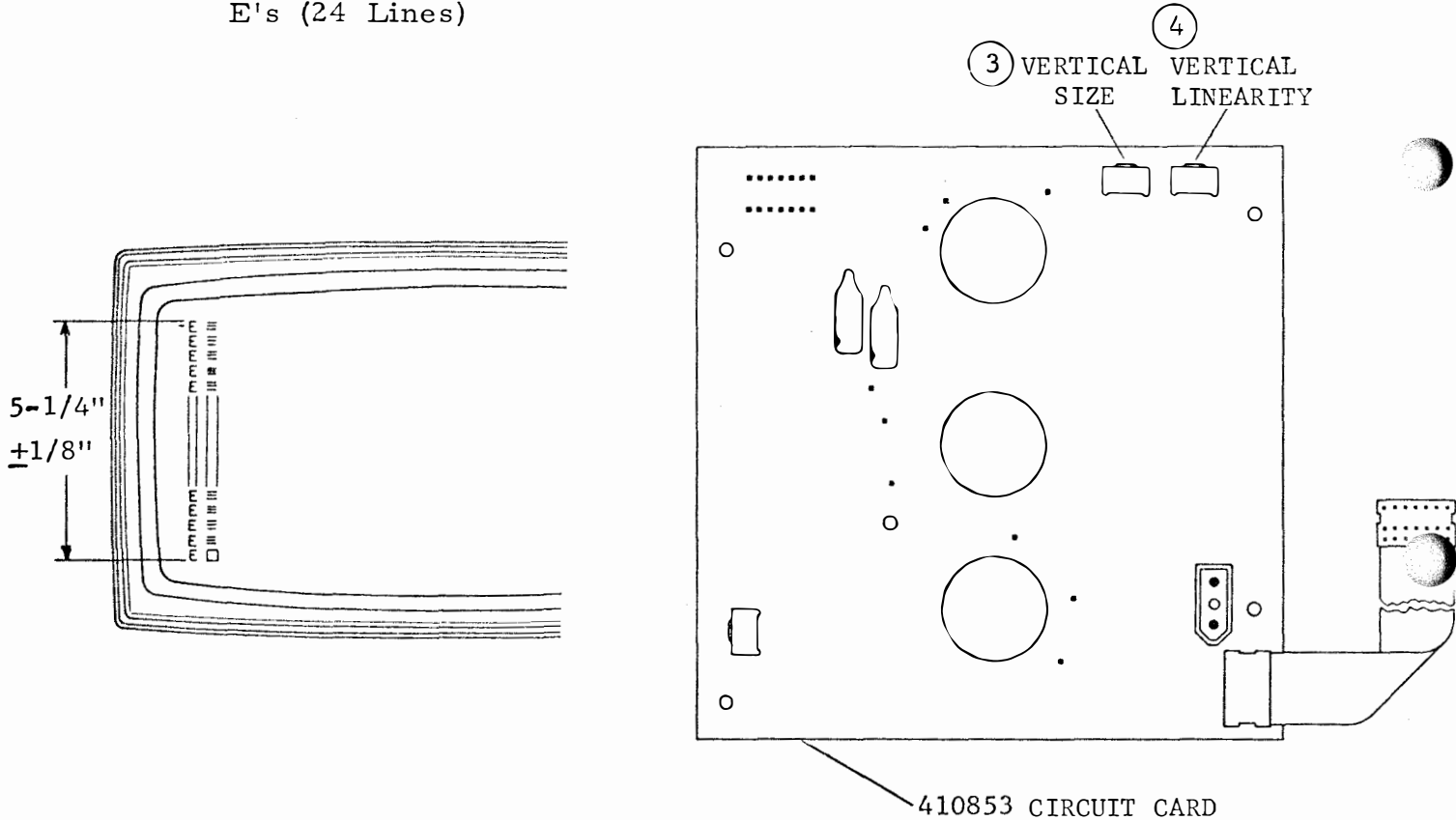

● VERTICAL LINEARITY

Potentiometer located on 410853 Circuit Card adjusts for uniformity of the character height.

Requirement: The height of a particular character in different locations of the display area should be equal as gauged by eye.

To Check: Visually compare the height if the characters in the left column (displayed in 1.3).

G. ADJUSTMENTS (Continued)

1. Electrical (Continued)

HORIZONTAL SIZE

Correcting coil located on 410854 Circuit Card combines with the Horizontal Linearity control to adjust the width of the display. (Open back panel. See Component Access Page 142.)

Requirement: $11\ 1/4" \pm 1/8"$

To Measure: Fill the top line of the display area with H's. (80 columns)
Move cursor down.

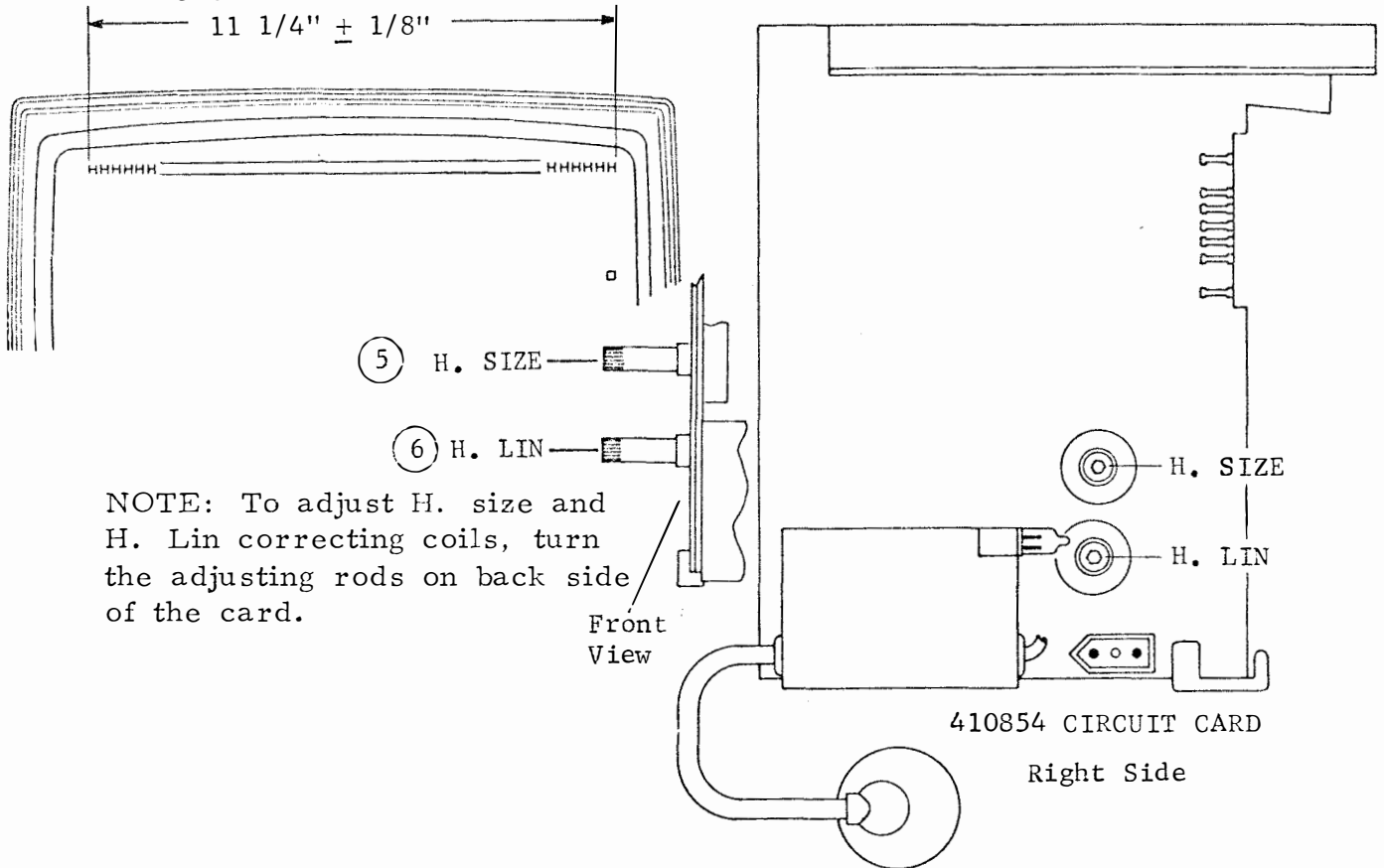

HORIZONTAL LINEARITY

Correcting coil located on 410854 Circuit Card combines with the Horizontal Size control to adjust for uniformity of character width.

Requirement: The width of a particular character in different locations of the display area should be equal as gauged by eye.

To Check: Visually compare the width of a line H's.

NOTE: Recheck the Horizontal Size Adjust and refine if necessary.

G. ADJUSTMENTS (Continued)

1. Electrical (Continued)

YOKE ORIENTATION

This adjustment provides rotary alignment of the rectangular display area relative to the cathode ray tube face.

- CAUTION:
1. High Voltages are present at the Yoke coils. The Yoke should be handled by its liner only.
 2. Unlike the face of the CRT, the rest of the tube, especially the neck is very fragile. Be careful not to strike the glass when working in its vicinity with screw drivers, etc.
 3. Do not over tighten the yoke clamp screw.

To Adjust: With the Yoke clamp screw friction tight, rotate yoke so that a line of display is parallel to the horizontal plane. Tighten the clamp screw carefully to the extent that it will adequately hold the adjustment.

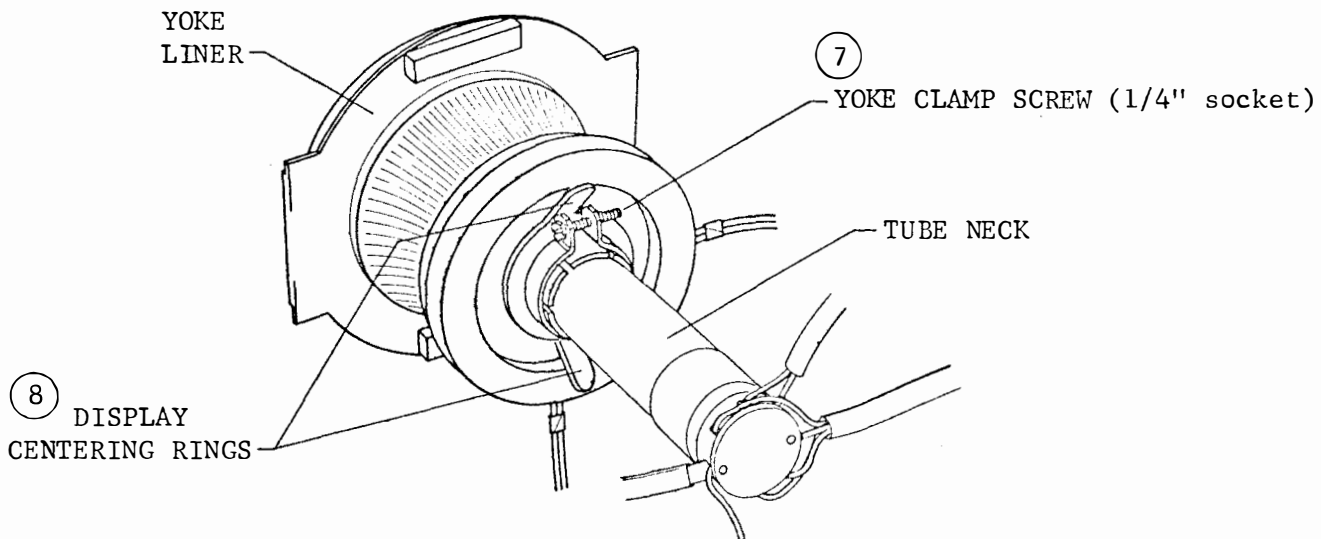

DISPLAY CENTERING RINGS

This adjustment positions the display up or down and left or right by moving the two centering rings.

To Adjust: Display a full line of characters at the top and bottom of the display area and manipulate the two centering rings by their tabs until the display is centered on the tube face. Gauge by eye. May be affected if picture size is adjusted.

G. ADJUSTMENTS

2. Mechanical

Tube Tilt Mechanism (Monitor Unit)

Requirement: Min backlash between wheel gear and rack.

To Adjust: Loosen eccentric locking nut and adjust eccentric with an 0.062 Allen wrench.

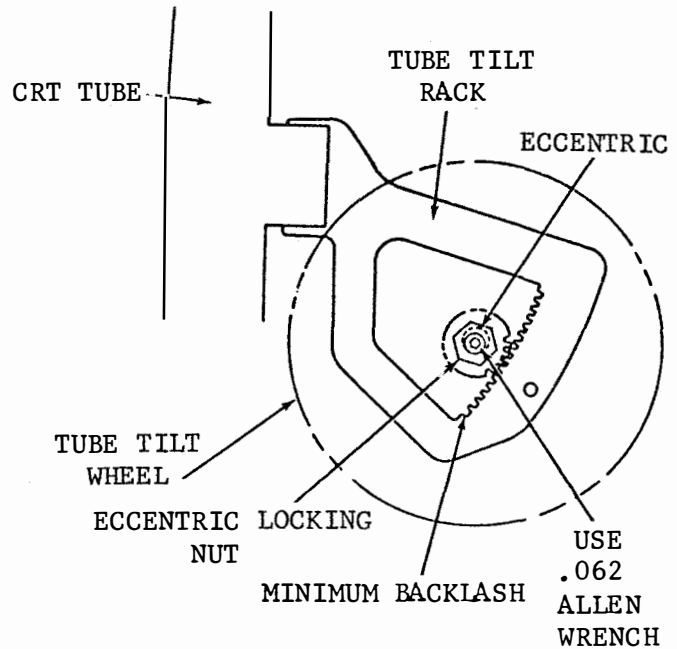

Fan Belt Tension (Electronics Package Ventilating Assembly)

To Adjust

- (1) TP401099 Motor Belt - Loosen motor mounting nuts and position motor up or down to meet requirement.
- (2) TP401048 Fan Belt - With the fan mounting nut friction tight, move the fan left or right to meet requirement.

Note: Lift edges of screen to allow lateral movement when positioning fans.

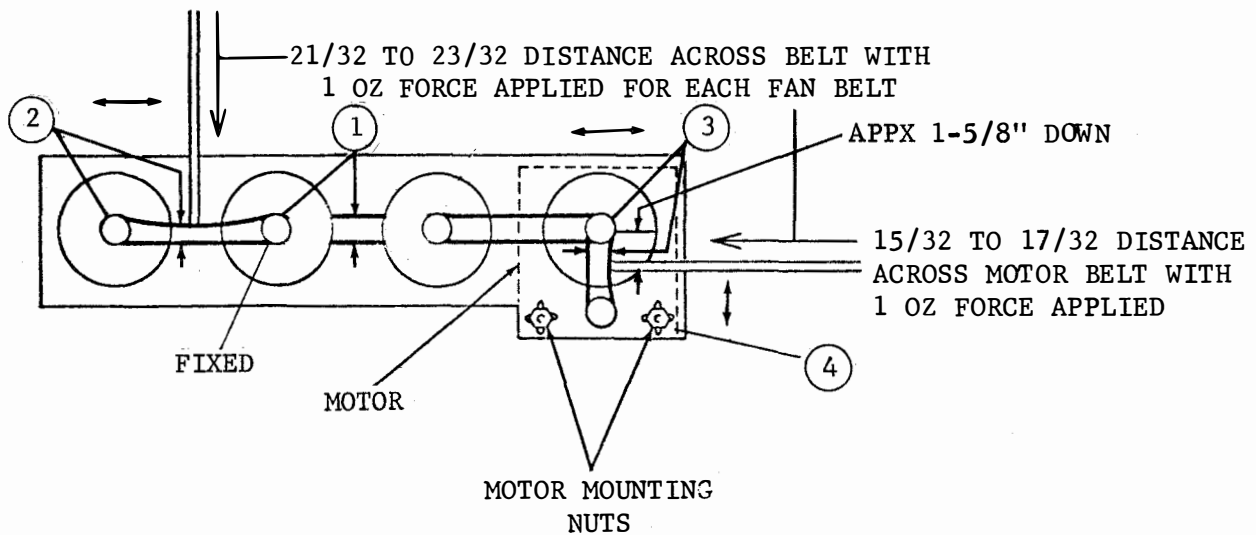

Rear View

- ① Sequence of belt adjustments



H. SERVICING

H. SERVICING

1. General

- This section contains servicing schematic wiring diagrams (logic and ac power interconnection), routine printer lubrication, visual checks, and cleaning.
- The servicing schematic wiring diagrams (paragraph 2) provides a general understanding of the electrical interconnections, and power controls for the major assemblies. It can be used during installation, trouble isolation, and servicing requiring any dismantling.
- At the time of installation and again after a few weeks in operation the complete lubrication of the printer (Paragraph 3) should be performed.
- Routine lubrication of the printer (paragraph 3) should be performed at the convenience of the customer, either once a year or every 2000 hours of operation (whichever occurs first).
- After installation, and during trouble calls or routine visits, the extra few minutes spent in checking over the equipment (in accordance with the following paragraphs 3, 4, and 5) may well avoid an additional trouble call.
- Never lubricate or attempt to adjust the keyswitch assemblies on the Operator Console. No lubricant of any type is to be used on the keyswitches.

H. SERVICING (Continued)

2. Schematic Wiring Diagrams (Continued)

a. EIA-KD or KD w/Adjacent PRINTER or PTI-KD

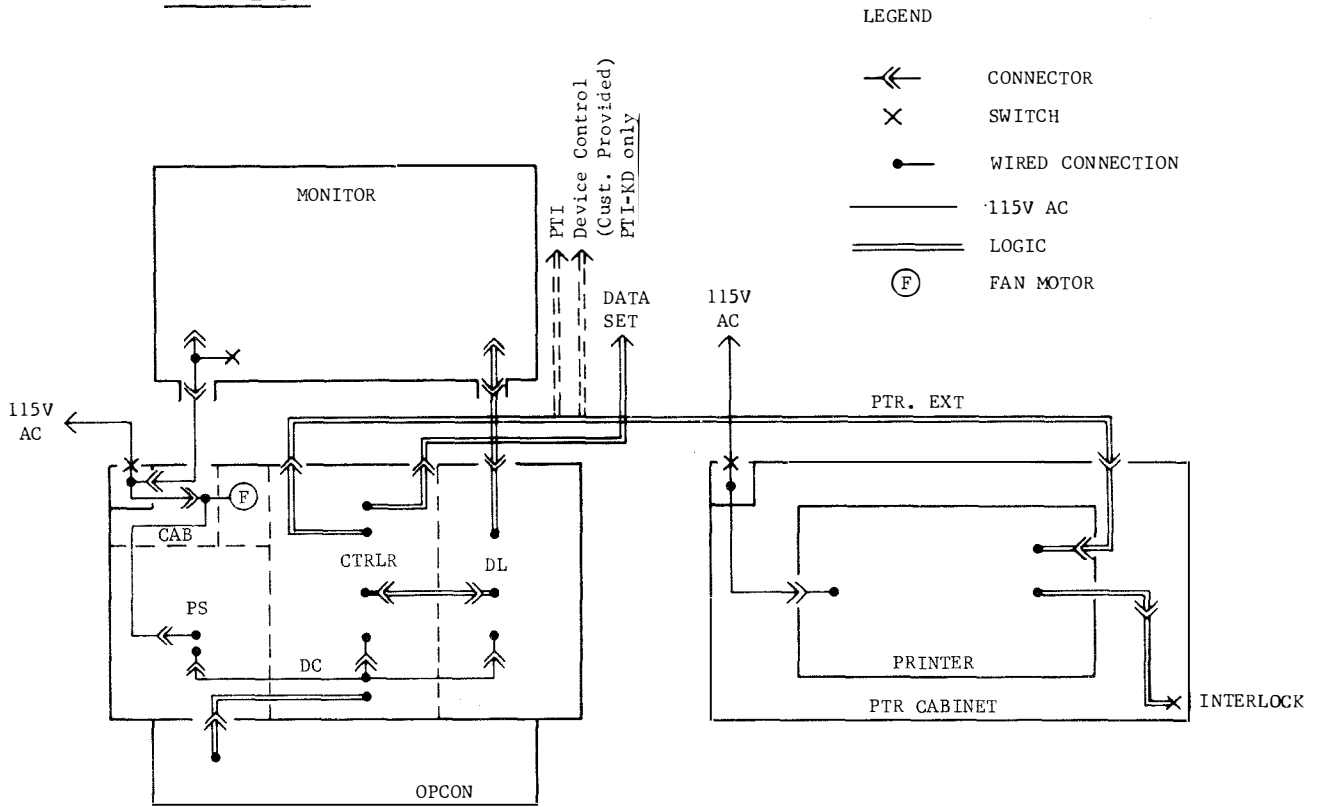

b. KDP - Table Top or w/Pedestal

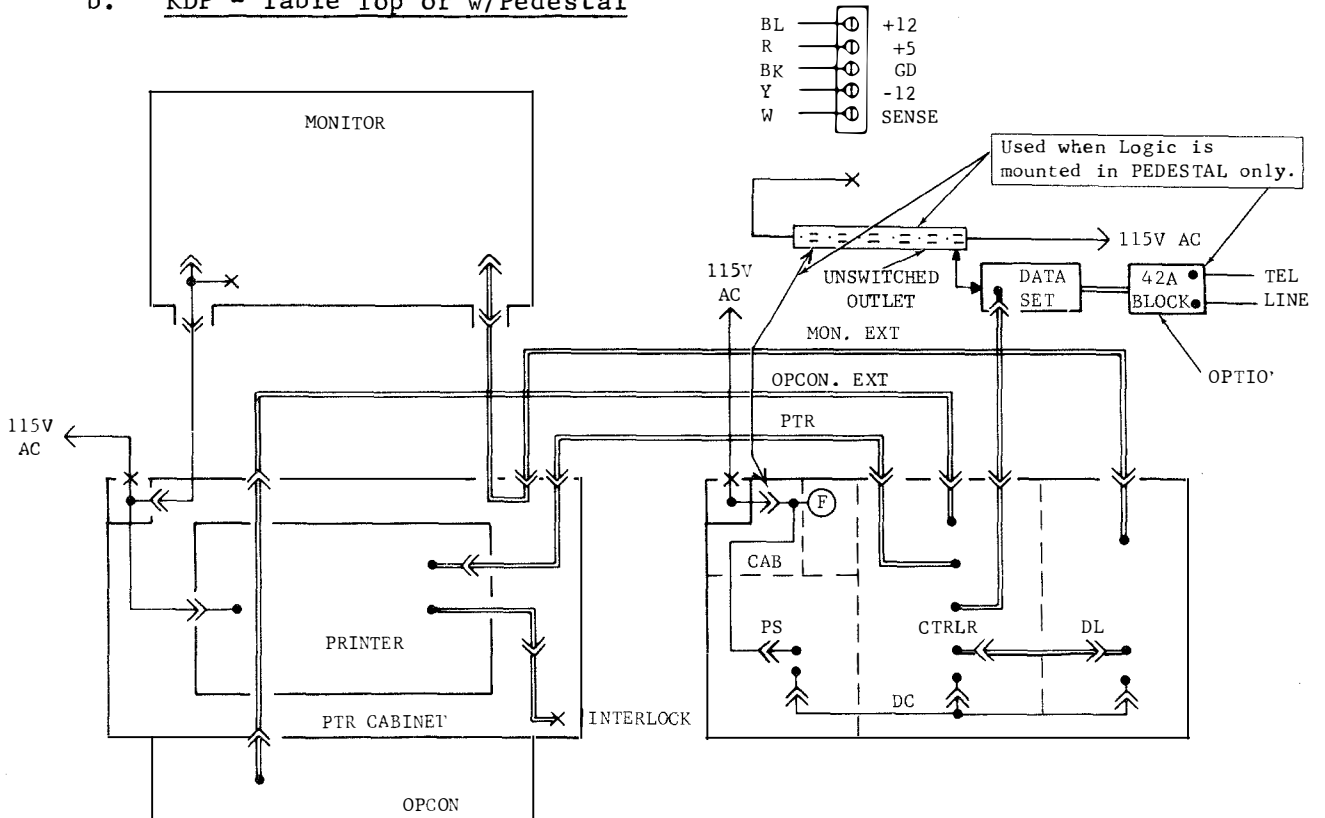

H. SERVICING (Continued)

2. Schematic Wiring Diagrams

c. EIA RO STATION

LEGEND

- ⏏ CONNECTOR
- × SWITCH
- WIRED CONNECTION
- 115V AC
- ≡ LOGIC
- ⊙ FAN MOTOR

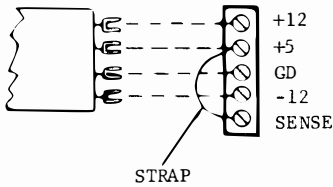
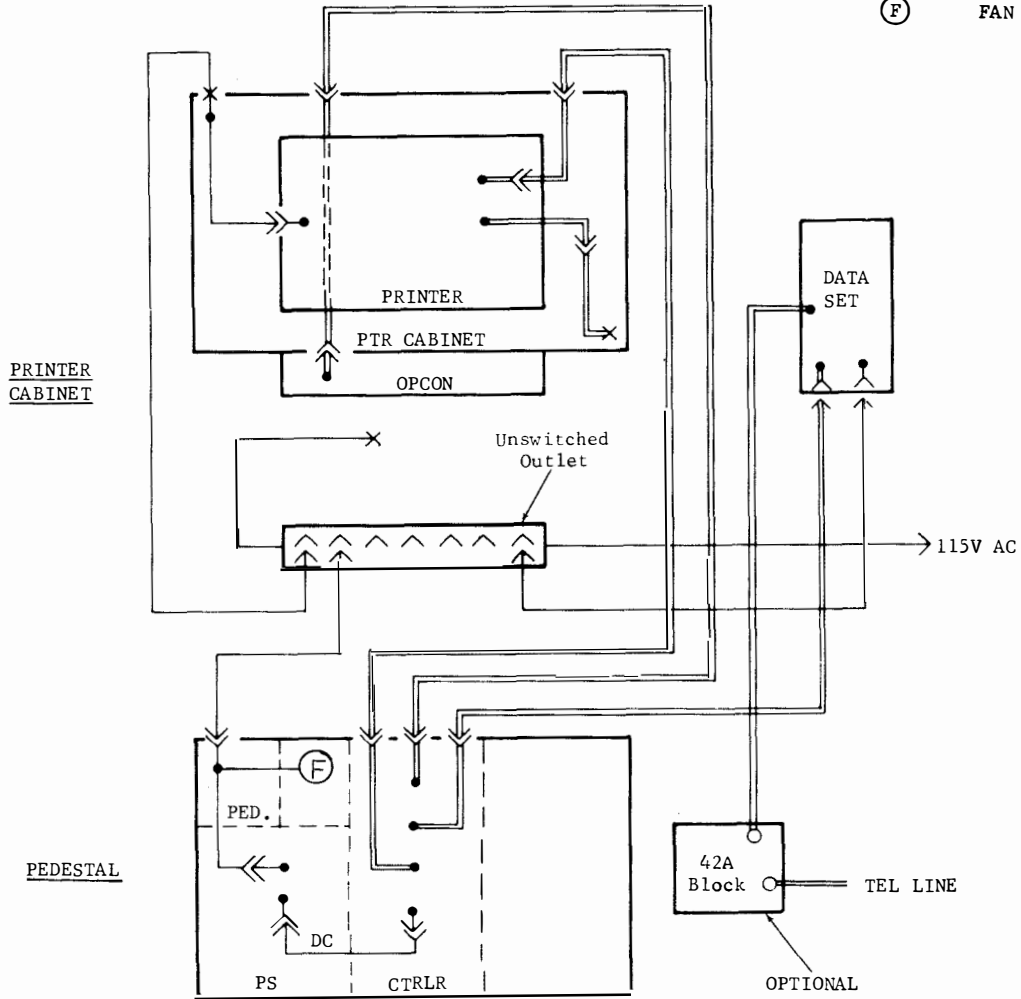

H. SERVICING (Continued)

3. Routine Lubrication

- Never lubricate or attempt to adjust the keyswitch assemblies on the Operator Console. No lubricant of any type is to be used on the keyswitches.
- This part of servicing section details the procedures for lubricating the M40 printer. Removal of printer from cabinet is not necessary to perform all lubricating requirements. The following instructions supplement the lubricating information contained in this section.
 - Apply oil to points as indicated.
 - On small parts, a minimum amount of oil should be applied so that the oil remains on the part and does not run off.
 - Excessive oil should be removed with a dry, lint-free cloth.
- The following areas must be kept dry, free of all lubricant.
 - All electrical components, including terminals.
 - All parts normally touched by the operator, including exposed surfaces in ribbon, paper handling areas and all large flat areas.
- The following symbols specify lubrication points, and type of lubricant used.
 - ③ Use KS7470 oil
 - Use a thin coat of KS7471 grease

H. SERVICING (Continued)

3. Routine Lubrication (Continued)

It is not necessary to remove printer for lubrication.

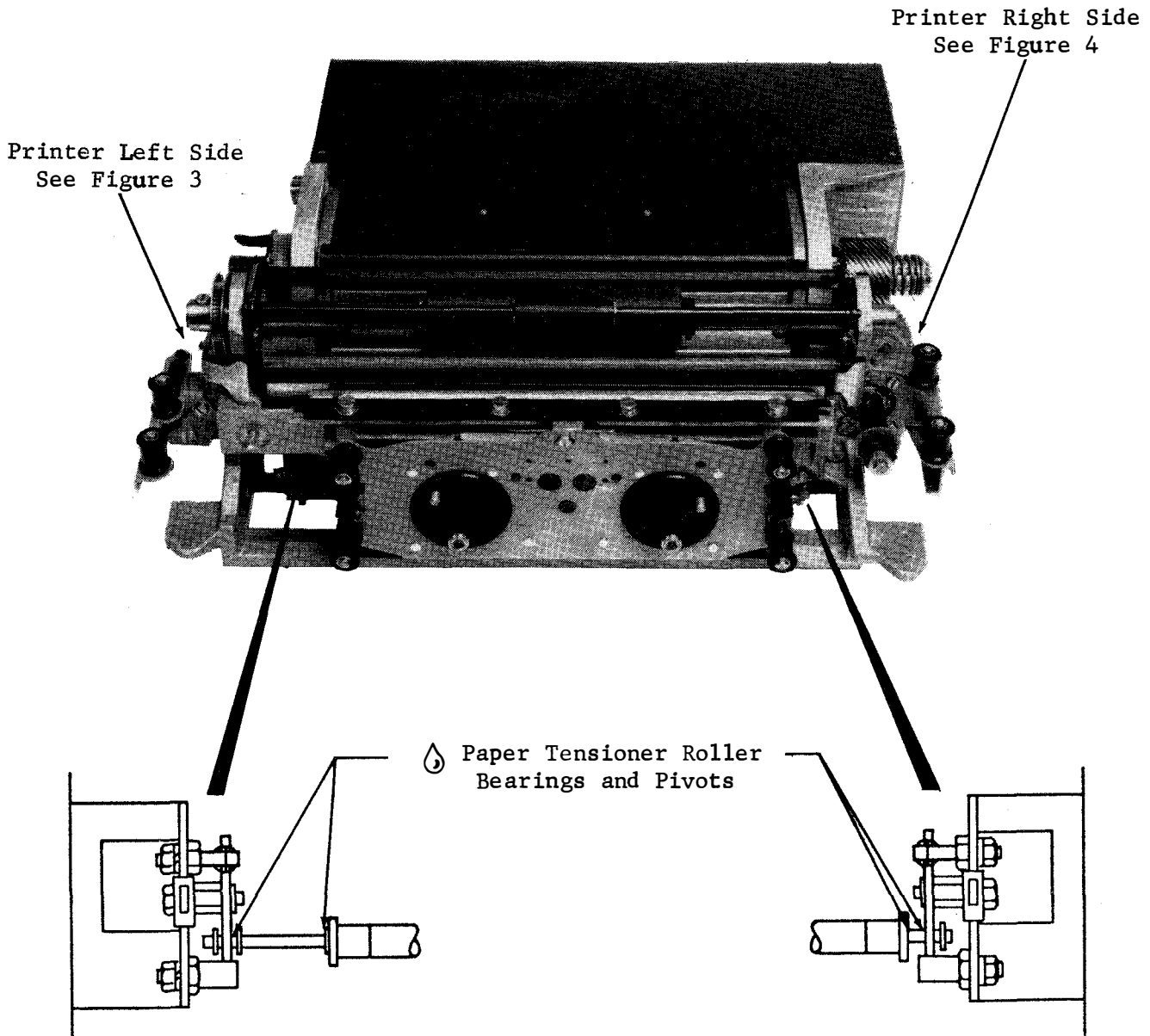

FIGURE 1. PRINTER

H. SERVICING (Continued)

3. Routine Lubrication (Continued)

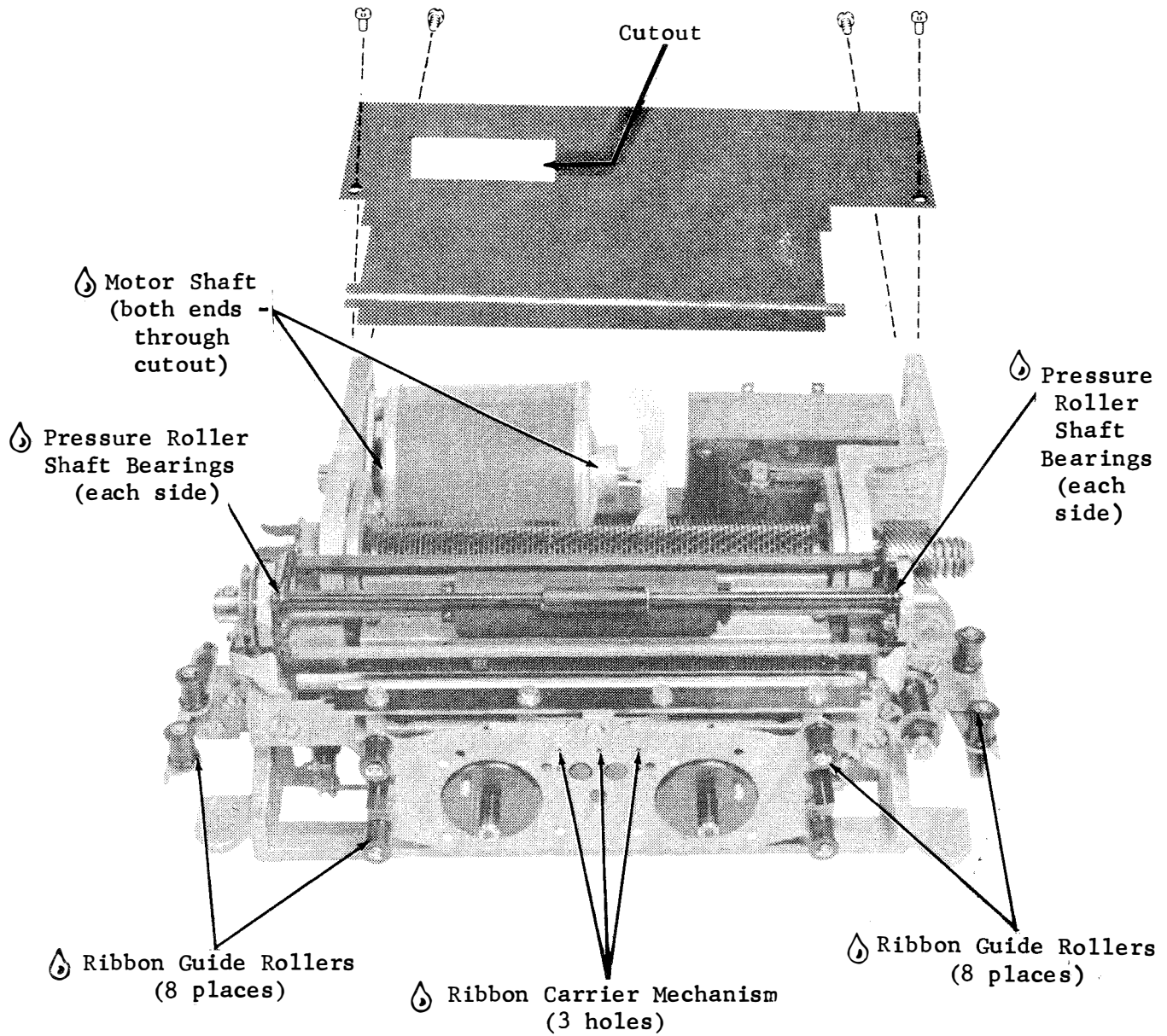

FIGURE 2. PRINTER

H. SERVICING (Continued)

3. Routine Lubrication (Continued)

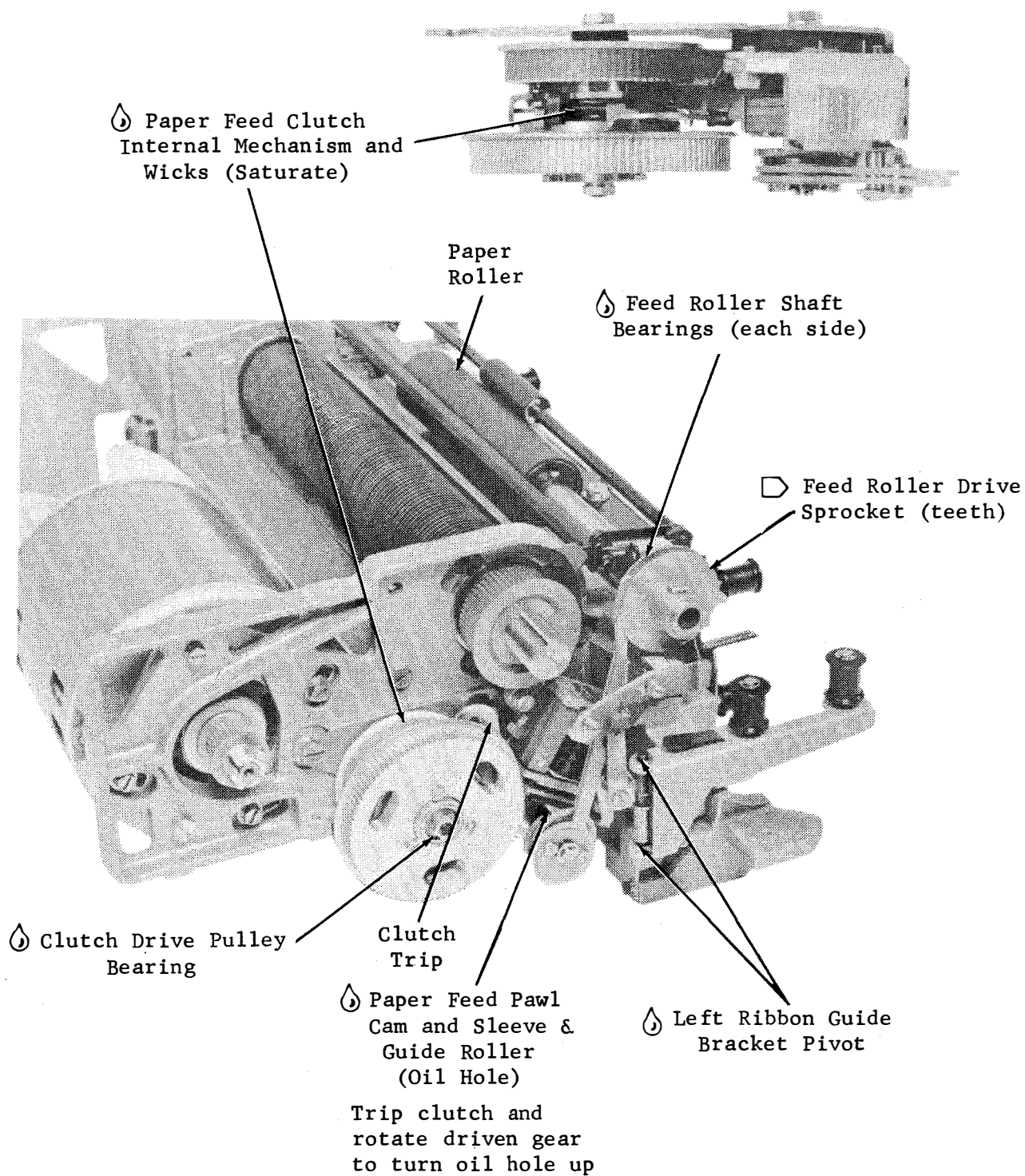
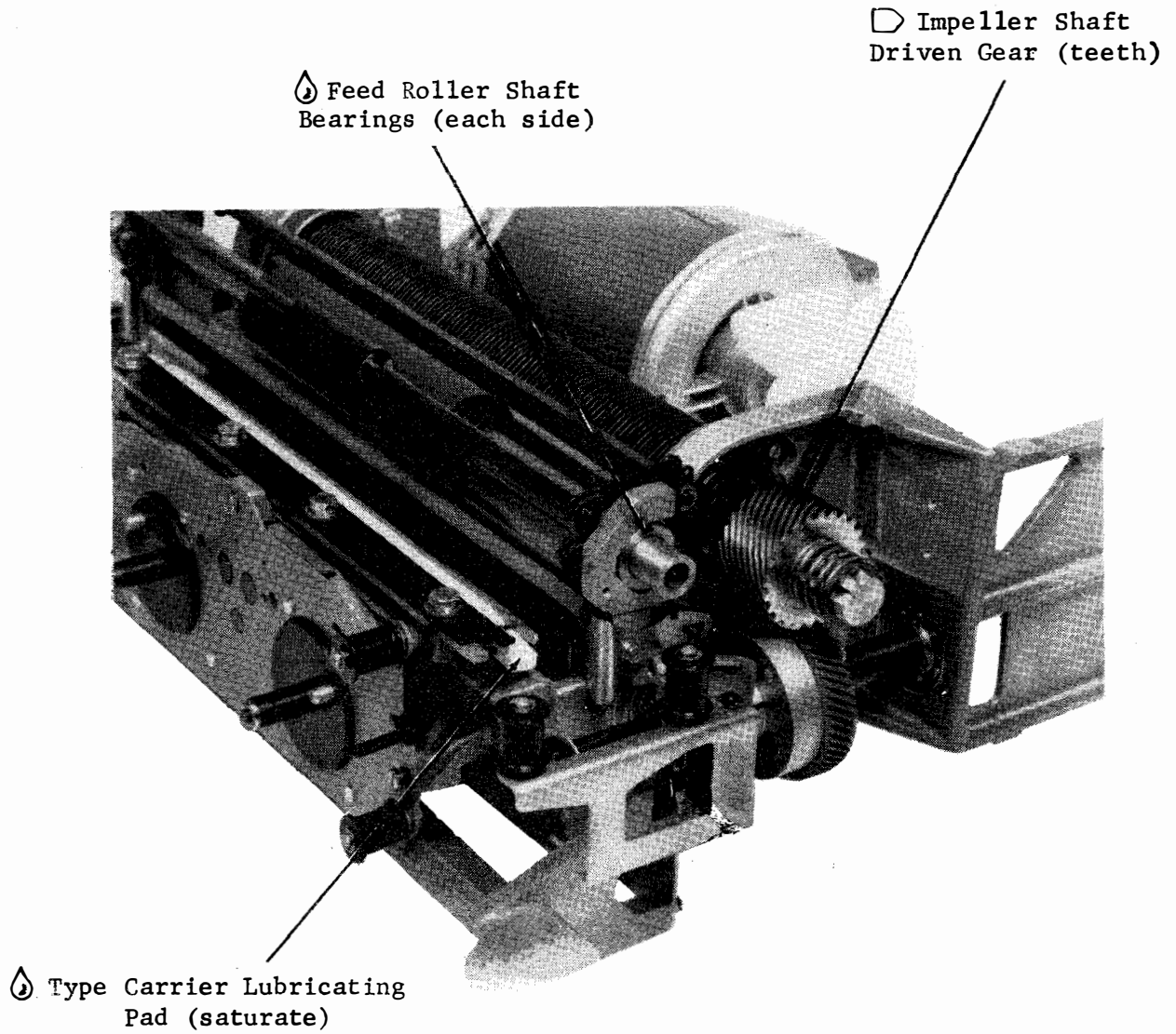

FIGURE 3. PRINTER - LEFT SIDE

H. SERVICING (Continued)

3. Routine Lubrication (Continued)



H. SERVICING (Continued)

4. Visual Checks

a. General

Make sure all connectors are seated properly and securely.

Look for any pinched or crimped wires or cables. Re-dress as required.

Make sure doors and panels open and close properly, and that latches open easily and close securely.

Make sure covers are secure.

Check that there is unrestricted air flow through the equipment where fans are used to circulate air.

On sets equipped with a printer, check appearance of printed copy (smearred copy might mean dirty type faces).

On sets equipped with a keyboard, check to see there are no loose keys.

b. Monitor

Remove monitor housing (Section F, page 141). If the monitor is too close to a wall to remove housing, lift the monitor off its mountings and place in a convenient location where housing can be removed. (Be careful not to let monitor tip over on its legs.)

Check for excessive build-up of dust.

NOTE: The high positive voltages utilized within the monitor attract dust particles. Dust build-up will probably be most noticeable in the areas of the flyback transformer, the deflection yoke, and the surface of the tube.

CAUTION: Excessive build-up of dust on a component can act as an insulator, and therefore can cause overheating (which can shorten the life) of the component.

Check the ventilating slots on the housing, to assure an adequate flow of air is possible.

H. SERVICING (Continued)

4. Visual Checks (Continued)

C. Grounding Straps

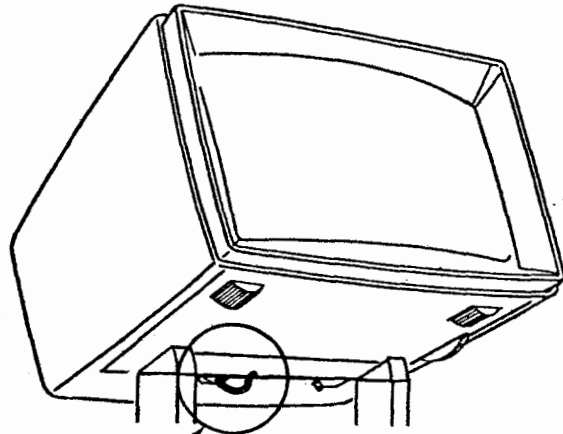
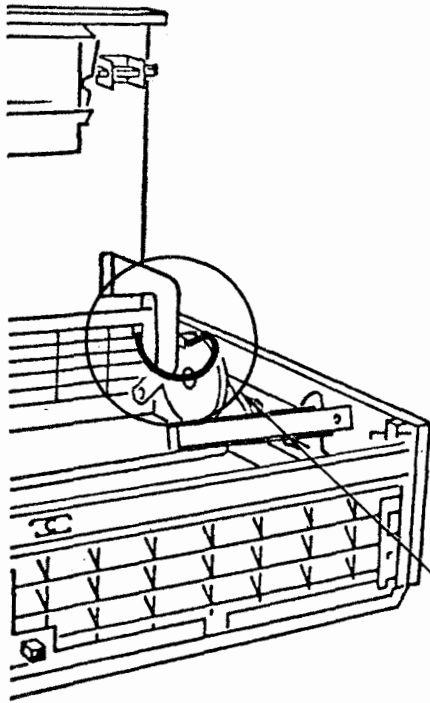

During servicing or prior to operational checkout make sure all grounding straps are connected.

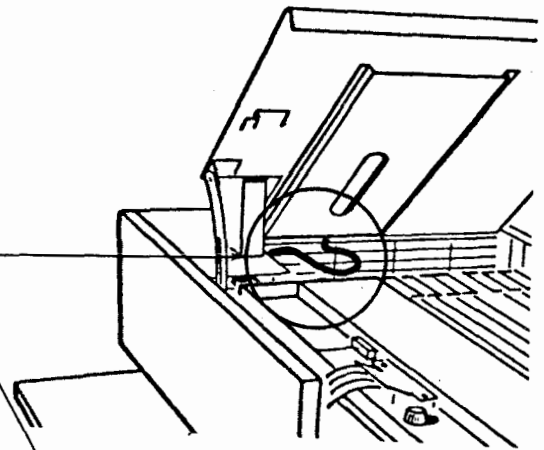

— BRAIDED

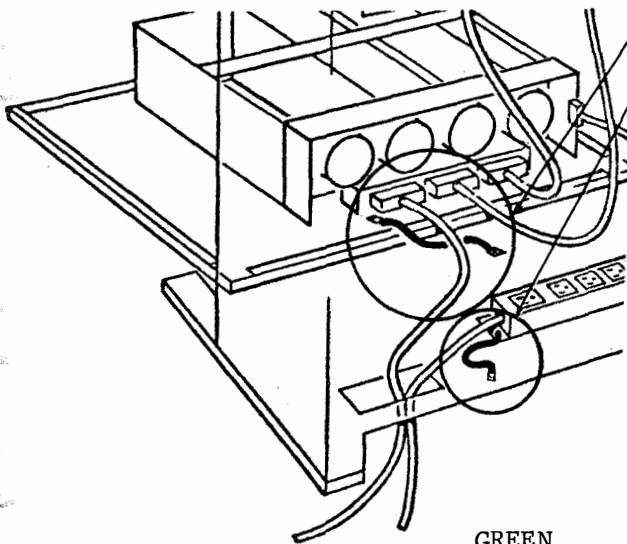

GREEN INSULATION

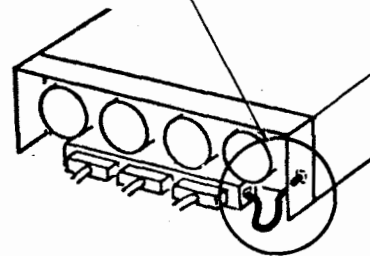



H. SERVICING (Continued)

5. Cleaning

a. General

Any protective screening through which air is drawn by cooling fans must be cleaned periodically. Restricted air flow will cause overheating.

Screening is probably most easily cleaned using a soft bristled brush (perhaps a typewriter brush, or a soft tooth brush).

b. Monitor

Any dust build-up can easily be removed by brushing it off with a very soft brush or soft, lintless cloth.

CAUTION: Be careful when working in the area of the picture tube. Keep any sharp objects, that could scratch the tube, out of the way (like a screwdriver that might drop out of a shirt pocket when leaning over the monitor).

The face of the tube can get dirty (also finger marked). Mild soap and water, and a soft cloth will clean it easily (nothing harsh, or the face of the tube could get scratched).

c. Printer

Raise the printer up to its ribbon changing position. If type faces are dirty, remove type carrier (Section F, page 149, paragraph 1.c.(4)) and clean type faces with a brush. Mineral spirits may be used.

Lower the paper chute, and wipe clean with a lintless cloth.

Clean paper roller.

