

TELETYPE CORPORATION

SCHOOL OF MAINTENANCE TRAINING

201 NORTH WELLS STREET

Chicago 6, Illinois

The Customer Service School provides, tuition-free, training for the maintenance personnel of Teletype's customers. As the School of Training is maintained for the customer, it is under the supervision of the Sales department.

Because there is no charge for the training provided, the Teletype Corporation will not assume the responsibility for making student's hotel reservations. For military personnel the School will, upon request, issue a form indicating time of arrival and departure. No certificate of non-availability of aircraft, rations or quarters will be issued.

Classes begin at eight o'clock and are in session until four forty-five in the afternoon. Breaks are scheduled for both morning and afternoon and a one hour lunch period is provided. Students may bring their lunch or eat at any of the numerous restaurants in the area. There are no classes on Saturdays.

Students are requested to observe the hours of the class and to be on time following each break. No extra training will be given students who come in late. Students who are repeatedly late will be asked to leave.

All text materials such as bulletins, charts and rulers may be retained by the student. Students are required to have a pen and/or pencil.

Although the classes are scheduled to run through four forty-five of the final Friday, some students complete the course earlier than others. Those who finish early may leave but no student may leave without completing the course unless he has special permission. Teletype personnel may not leave the School at any time unless they have the permission of their supervisor, lunch and break periods excepted.

The school's telephone may be used ONLY by instructors and Teletype personnel on company business.

The address and telephone number of the school is:

ADDRESS 201 N. Wells Street

PHONE Financial 6-0586

Your instructors will be:

The course of instruction covering the Model 28 Keyboard and Printer is two weeks long. Normally, the material will be covered according to the schedule below. However, certain conditions such as holidays, tend to alter the schedule slightly.

DAY	SUBJECT
1st.	Keyboard theory - Disassembly & assembly
2nd.	Keyboard adjustments
$\frac{1}{2}$ 3rd.	Keyboard adjustments
$\frac{1}{2}$ 3rd.	Printer theory
4th.	Printer theory
5th.	Printer theory - Disassembly & assembly
6th.	Printer adjustments
7th.	Printer adjustments
8th.	Printer adjustments - Adjustments under power
9th.	Trouble Shooting
10th.	Trouble Shooting

The keyboard and printer theory is presented to the class as a whole or to separate groups. All adjustments are given, a few pages at a time, to separate groups.

With the exception of a few basic mechanisms, the school places no particular emphasis upon the retention of part names. However, the student must have an understanding of theory in order to trouble-shoot effectively.

Each student will have a keyboard and printer, the adjustments for which are his responsibility. After the adjustment has been demonstrated by the instructor the student will make the adjustment. It is felt that only by actually making the adjustment will the student understand how it is properly made and the difficulties that might be encountered.

Many students who have had previous experience with other models of Teletype equipment will be familiar with the types of adjustments that will be called for. They are:

1. Clearance: A measurement, USING THE GAUGES PROVIDED, will be required. Unless otherwise specified, the measurement will be taken at the point of minimum clearance. Should the requirement, for example, read: "Min: .002" Max: .020" ", any point between the two limits will be satisfactory.

2. Spring Tensions: Ordinarily we do not change springs in the school's equipment unless it is broken or badly distorted. For this type of check, it is usually satisfactory for the student to know where and how the tension should be measured.
3. End Play: Although the adjustment manual will give the point at which the required end play may be measured, it is usually satisfactory to check the particular part for freedom from bind without excessive slop.
4. Double Requirements: Some adjustments have two requirements. Both are to be met with the same adjustment.

Below are listed the tools issued to each student. It will be the student's responsibility to return all tools at the end of the course.

QTY	NAME	USE OR DESCRIPTION
1	Handwheel	Turn the printer mainshaft manually
1	Armature clip	To hold the armature in a MARKING position for off-line checks.
2	Spring Hook	(1) Push hook (1) Pull hook
1	Crochet Hook	Small springs
1	Tweezers	
2	Screwdrivers	(1) Large (1) Small
2	Offset screwdrivers	(1) 90 degree (1) 45 degree
3	Spring scales	(1) 8oz. (1) 32 oz. (1) 64oz.
1	Tommy wrench	For "Transfer Lever Eccentric" adjustment
1	Screw starter	
1	Keylever remover	Remove keylevers from keyboard
1	Box of gauges	.002" through .008"; .010"; .012"; .018"; .020"; .025"; .030"; .035"; .037" .040" through .080" in steps of .005"

At the end of the course, the instructor is required to fill-out a report on each student. The report is submitted to the customer who sponsored the student. The report indicates starting and completion dates and a grade covering attitude and performance in theory, adjustments and trouble shooting.

In ordinary telegraph transmission, intelligence is relayed from one point to another by the making and breaking of the signal line. An operator at one end would open or close a telegraph key and cause a sounder at the receiving end to emit pulses of sound which could then be translated into characters by the other operator, trained to recognize the various code combinations. During the latter part of the nineteenth century, telegraphy took a step forward by substituting a mechanical sending mechanism for the old telegraph key, and a printer for the receiving station.

The new method of printing telegraphy, however, required modification of the old signaling method. The primary change has been in time control of the transmitted pulses. Specified time intervals or pulse lengths have replaced the, somewhat arbitrary, dot-dash system.

As devised by Jean Baudot, a French Signal Officer, the newer code requires that each character have a certain number of current and non-current time intervals (MARK or SPACE pulses) to indicate a particular code combination. It was decided that the intelligence portion of each complete character should have five of these time intervals. It may be seen that with two possibilities (MARK or SPACE) for five pulses:

$$2^5 = 32 \text{ possible code combinations}$$

Therefore, with the addition of an upper case, (figures) the Teletype Printer is capable of performing twice as many operations (printing or performing a function) as the number of available code combinations.

In the lower case, or letters, we have the 26 letters of the alphabet plus 6, so-called, "functions". These functions are mechanical operations of the printer as opposed to the actual printing of a character.

They include:

Letters (LTRS) = Either shifting the typebox to the letters segment or, as in the M15, shifting the platen down.

Figures (FIGS) = Just the opposite of letters

Space = Moving the printing mechanism to leave a blank between words.

Carriage Return (C.R.) = Returning the printing mechanism to the left margin.

Line Feed (L.F.) = Feeding the paper out of the printer.

Blank = All pulses spacing -- used for various operations

The length or time duration of the individual pulses is determined by the operating period of the various cams and levers that cause the signal line contacts to open and close. It may be seen, then, that as the operating speed increases, the pulse length decreases.

At this time three basic speeds are in popular usage. They are: 368rpm; 460rpm; and 600rpm. An expression, of these speeds, in "words-per-minute" has been roughly approximated by dividing each figure by 6. (This assumes that a "word" is composed of five characters and a space). Thus, 368 becomes 60 words-per-minute, 460 becomes 75 words-per-minute and 600 becomes 100 words-per-minute. For maintenance or other technical purposes, however, it is far more accurate to deal only with actual shaft speeds.

If, for every revolution of the transmitting shaft, a complete character is transmitted, we may refer to 368 characters or 368 operations-per-minute (opm). This breaks down:

$$(a) \quad \frac{368}{60} = \text{operations-per-second} = 6.13 \qquad (b) \quad \frac{1 \text{ second}}{6.13} = \text{length of one operation} = .163 \text{ sec.}$$

(c) At 368opm, then, one operation take .163 seconds or: 163 milliseconds (ms.)

To maintain synchronism between the sender and the receiver, it is necessary to establish a starting point and a stoping point. Consequently, to our character combination of five pulses there has been added a START pulse and a STOP pulse. These pulses are not considered information pulses. In the systems used by most companies, the START pulse is the same length as an information pulse while the STOP pulse is somewhat longer. The STOP pulse is longer to insure that the receiving machine has time to complete detection of the last information pulse before the transmitter begins a new character. The STOP pulse, in most cases, is 1.42 (or 142%) times as long as the START or information pulse. If we designate the START (or standard pulse length) as 1 unit, we have:

$$(d) \quad \begin{array}{rcl} \text{START} & = & 1 \text{ Unit} \\ \text{Information pulse} & = & 5 \text{ Units} \\ \text{STOP} & = & \underline{1.42 \text{ Units}} \\ & & 7.42 \end{array}$$

(e) 7.42 is known as the UNIT CODE

Western Union, as an alternate example, has a STOP pulse the same length as the START or information pulse. With all seven pulses the same duration, Western Union would be operating with a 7.00 Unit Code.

To determine the time duration of any pulse:

$$(f) \quad \frac{.163 \text{ sec (time for one complete operation)}}{7.42 \text{ (units)}} = 21.96 \text{ or } 22\text{ms.} = 1 \text{ Unit}$$

$$(g) \quad 21.96 \times 1.42 = 31.18\text{ms or } 31\text{ms.}$$

(h) The START or information pulse (1 Unit) = 22ms.

(i) The STOP pulse (1.42 Units) = 31ms.

The normal, or "rest" condition of the signal line is closed, that is, with current on the line. If the normal condition is closed, the beginning or START pulse must alter that condition. Obviously, then, the START pulse must be no-current or SPACING. The end of the transmission must return the signal line to its normal condition so the STOP pulse must be current or MARKING. As seen on an oscilloscope and assuming no distortion, the character 'Y' would look like this:

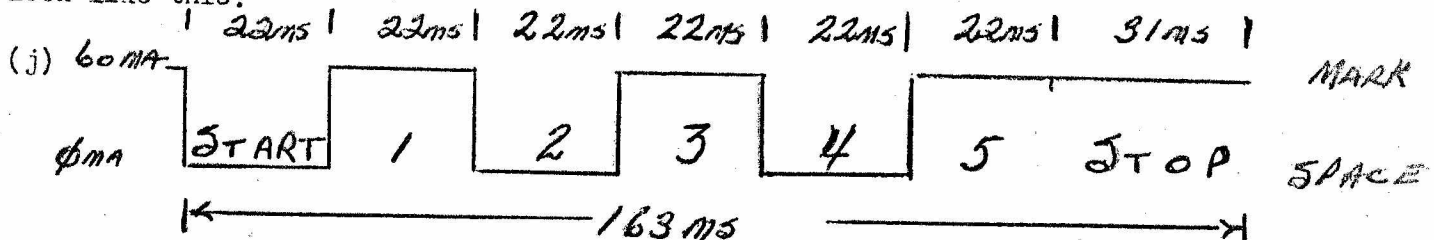

The character 'Y' is most often used for illustration and test purposes because every other pulse is different. As indicated on the rulers, however, the information pulses (between the START and STOP pulses) may vary according to the character selected. It has been noted that the STOP pulse is 1.42 times as long as the START or information pulse. This, of course, assumes continuous operation. Otherwise the STOP pulse might be 31ms, 31 minutes or ten days -- depending upon when the next character was transmitted.

POLAR OPERATION: Up until now, only NEUTRAL operation has been considered. In Neutral operation, a SPACE is when there is no-current on the line and a MARK is when there is current on the line (60ma or 70ma). In Polar operation, there is current on the line at all times and it is the difference between the current polarity that determines whether a MARK (+) or a SPACE (-) is being transmitted. Obviously the printer could not be hooked, directly, to a polar signal because current, no matter what polarity, would energize the selector magnets.

BAUD (from Baudot): An expression which combines shaft speed (operations-per-second) and unit code into one usable term or figure. It also indicates the maximum number of pulses-per-second. It is derived by multiplying the operations-per-second by the unit code:

(k)

$$\frac{368 \text{ opm}}{60} = 6.13 \text{ ops/sec} \times 7.42 \text{ (Unit Code)} = \underline{45.5} = \text{Baud}$$

In the case of Western Union, both the operations-per-second and shaft speed differ:

$$(1) \frac{390 \text{ opm}}{60} = 6.5 \text{ ops/sec} \times 7.00 \text{ (Unit Code)} = \underline{45.5} = \text{Baud}$$

It may be seen, in the above illustrations, that although both shaft speed and unit code differ, and Western Union machine may operate with any Teletype product because their BAUD is the same.

DOT CYCLE FREQUENCY: Each MARK-to-SPACE transition comprises a rectangular wave. Any rectangular wave is made-up of a fundamental sine wave plus a number of sub harmonic frequencies. This fundamental, or Dot Cycle Frequency of any character may be determined by dividing the length of one MARK-to-SPACE transition into one. Inasmuch as the character 'Y' changes from MARK to SPACE every other pulse, one MARK-to-SPACE transition would be equal to the length of two pulses or .044sec.

$$(m) \frac{1}{.044} = \text{approx. } 23\text{cps} = \text{Dot Cycle Frequency of character 'Y'}$$

The character 'M' (3,4 & 5 MARK) does not have as many transitions as 'Y'. For 'M', the START, first and second pulse would be one part, while the third, fourth and fifth pulses would be the other part of its rectangular wave form.

$$(n) \begin{array}{l} \text{START + First + Second} = 66\text{ms.} \\ \text{Third + Fourth + Fifth} = 66\text{ms.} \end{array}$$

$$132\text{ms.}$$

$$\frac{1}{.132} = \text{approx. } 8\text{cps} = \text{Dot Cycle Frequency of character 'M'}$$

The Dot Cycle Frequency is important in determining the necessary bandpass for Teletype transmission. If the highest frequency can get through, all others may. Consequently, the character 'Y', with the maximum number of transitions, provides this maximum or reference frequency. It has been found that the fundamental frequency plus the next ten or eleven harmonics provides a good signal. The BELL system, however uses only the third or fourth (around 89cycles) for their bandpass.

For purposes of illustration Teletype pulses are shown as perfect rectangular waveshapes with sharp transitions and precise timing. This optimum condition is seldom, if ever, found in actual practice.

The modification of the original, rectangular waveshape is called Distortion. The Total Distortion to any signal is broken-down into three categories for purposes of classification but it is important to note that any signal may contain all three components of distortion. The three components of distortion are:

Bias Distortion
Characteristic Distortion

Fortuitous Distortion

Bias and Characteristic Distortion are combined in the term Systematic Distortion because both occur in response to natural law and, consequently, either is roughly predictable. With the third element, Fortuitous Distortion, every possible modification is accounted for -- and labeled Total Distortion.

Bias Distortion

Bias Distortion effects all pulses uniformly and its effect upon a MARK is opposite to its effect upon a SPACE. Bias may effect either the beginning or the end of an impulse but inasmuch as the selector always begins with the MARK-to-SPACE transition of the Start pulse, the total effect of bias is to advance or retard the leading edge of any impulse with respect to the Start pulse.

Before illustrating Bias, it will be necessary to indicate the effect, upon a signal pulse, by the resistive, inductive and capacitive elements in the signal line.

1. Perfect MARK impulse
2. Line INDUCTANCE opposes sudden transitions of current. Inductance from Line Relays and/or selector magnet coils.
3. Line CAPACITANCE shunts the signal line preventing rapid current build-up and, thus, further sloping the edges of the wave.

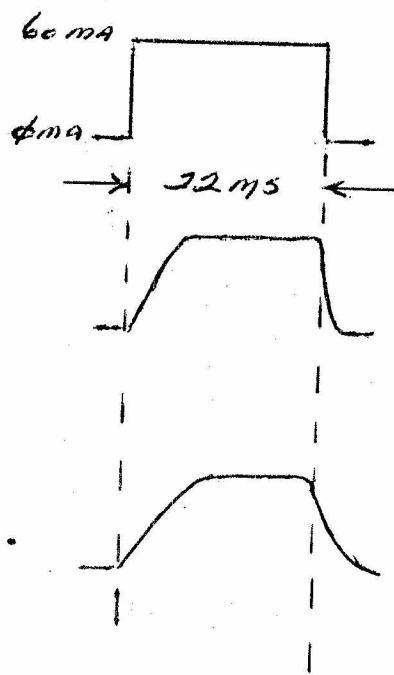

The impulse in figure 3 is more likely to be found at the receiving printer than the one (figure 1) impressed at the transmitter. The impulse seen in figure 3, as applied to the selector magnets of the printer, will be used to illustrate Bias Distortion. It will be noted that this waveshape builds up to its 60ma level gradually -- due to the reactive elements of the signal line.

Instead of picking-up at the leading edge of the pulse (T1), the selector magnet will energize at a somewhat later time -- say, for example, at T2 -- or whenever the current has reached a level where it generates sufficient magnetic attraction. This point, T2, would be the beginning of the MARK impulse as far as the selector was concerned.

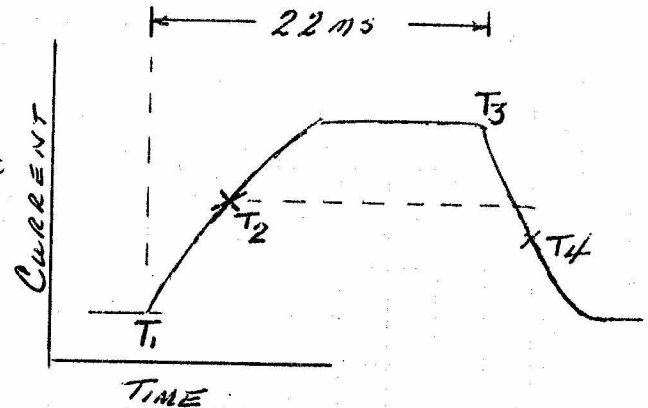

When, at the end of the transmitted pulse, the current again starts towards 0ma., the selector armature should, theoretically, fall away at T3. The trailing edge of the impulse, however, also slopes and, consequently, a definite time will have elapsed before the armature will drop away (T4). Notice that T2 and T4 are not identical current values. The de-energization point will be a lower value due to residual magnetism in the coils and, conceivably, to weak spring tension.

The time between when the armature should attract (T1) and when it does attract (T2) is known as SPACE-to-MARK TRANSITION DELAY. (abbreviated S-MTD)

The time between when the armature should drop away (T3) and when it does drop away (T4) is known as MARK-to-SPACE TRANSITION DELAY (M-STD).

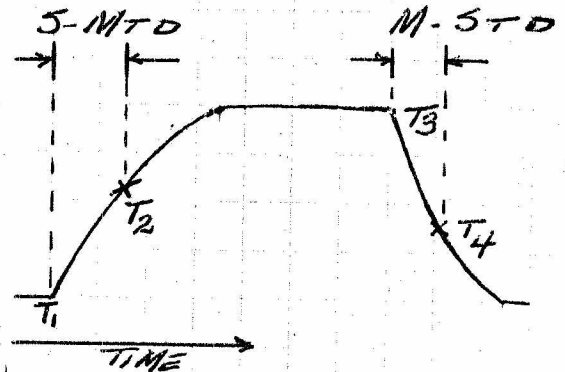

If the S-MTD is equal to the M-STD, the pulse as seen by the selector would be undistorted.

If the S-MTD is greater than the M-STD the pulse has been shortened and the condition is known as SPACING BIAS

If the M-STD is greater than the S-MTD the pulse has been lengthened and the condition is known as MARKING BIAS

The BELL System uses the following formula to determine the actual Bias condition in milliseconds (ms.). The sign of the result indicates whether the Bias is MARKING (+) or SPACING (-).

$$M-STD - S-MTD = \text{ms. Bias}$$

This example of Bias Distortion illustrates that although the M-STD may not equal the S-MTD, the two will be consistent for any given circuit and/or adjustment. It will be noted, also, that the effect of Bias will:

- a) Be the opposite to a SPACE from its effect upon a MARK.
- b) Be consistent for any character combination.

Characteristic Distortion

Characteristic Distortion, as the name implies, is determined by the signal line characteristics. That is, the resistance, capacitance and inductance. This type of distortion will effect different characters in different ways but it will always be consistent for the same character. In neutral operation, Characteristic Distortion will effect Bias.

Characteristic Distortion has varying effects upon different characters because the circuit's reactance will have less chance to become stabilized when characters with many current transitions are applied ('Y', for example) than when characters with few transitions are applied ('M', for example). It may be said that the effect of Characteristic Distortion is inversely proportional to the Dot Cycle Frequency of the character transmitted.

The contrasts between Characteristic Distortion and Bias may be summarized as follows:

1. The effect of Characteristic Distortion depends upon the length of the impulse transmitted. The effect of Bias is independent of the length of the impulses.
2. For a given length of impulse, the effect of Characteristic Distortion is independent of whether it is a marking or spacing impulse. The effect of Bias is always opposite on a mark to what it is on a space.
3. Characteristic Distortion is related to the amount and arrangement of the capacitance, inductance and resistance of a circuit. Except in neutral operation, these factors do not effect Bias.
4. Bias is caused by unequal marking and spacing line current, biased relays etc., conditions which do not effect Characteristic Distortion.
5. Characteristic Distortion, because it is due to the capacitance, inductance and resistance of a circuit, which, except for the resistance, are unchanging in value, varies only a small amount from day to day. Bias, because it is caused by uneven potentials, relays losing adjustment etc., may vary from hour to hour.

Fortuitous Distortion

This form of distortion covers such unpredictable occurrences as sudden battery fluctuations or loose ground connections. This distortion may effect any portion of any character and little or no compensation may be made for it.

RANGE

All Teletype receivers (i.e. printers, perforators etc.) are equipped with a range scale. In every case, the function of the range scale is to orient the mechanical selector to the electrical signal to obtain maximum selecting margins.

The selecting interval of the impulse (i.e. when the actual selection is made) is only 20% of the pulse width or 4.4ms. Consequently a perfect selector should be able to tolerate 40% distortion of both leading and trailing portions of an impulse.

In a perfect impulse of 22ms duration, the necessary 20% selecting interval would be in the center with a range reading of 10 to 110:

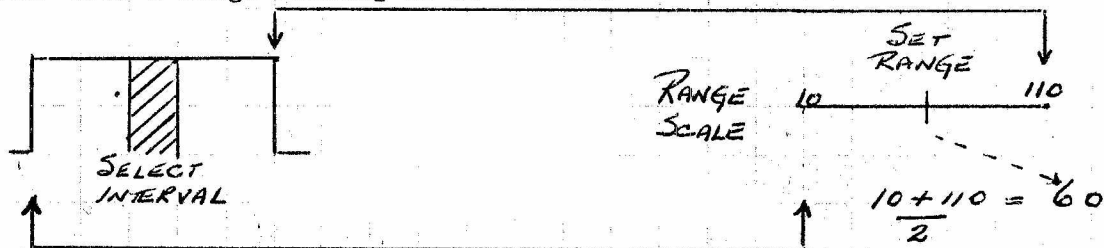

If 20% MARKING END DISTORTION (an artificially produced characteristic distortion used to test acceptance -- in this case it would extend the leading edge of the pulse) were introduced, the range would shift in order to maintain the selecting interval in the middle of the pulse:

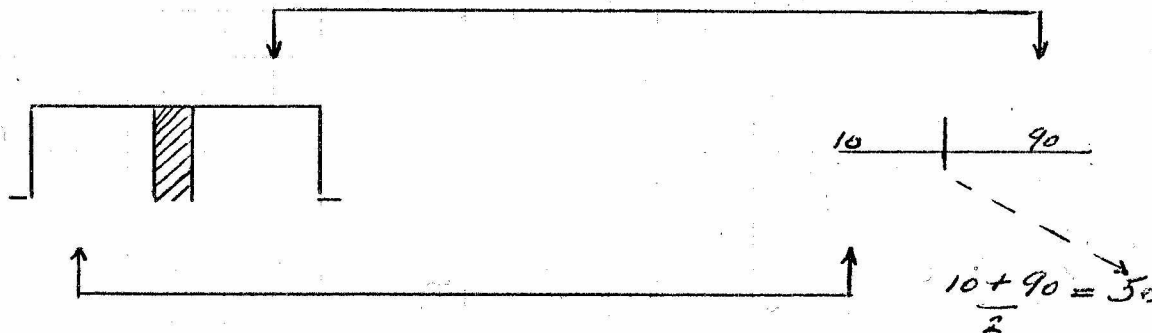

If 20% SPACING END DISTORTION were introduced the range would shift in an opposite direction:

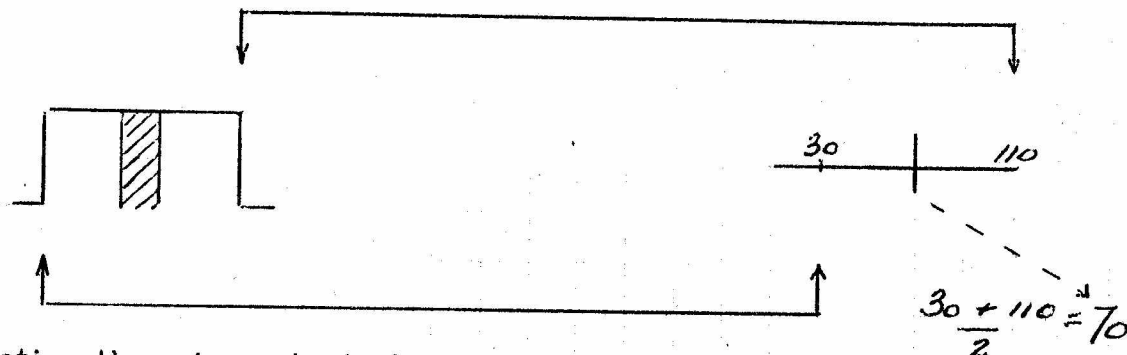

In any situation there is a standard procedure for determining the proper setting for the range scale:

- a) Determine the high and low points on the range scale by observing errors in copy.
- b) Add the high point to the low point and divide by two. (See examples in range illustrations)

 Most of the information on Signal Distortion and Range was taken from:

- PRINCIPLES OF ELECTRICITY APPLIED TO TELEPHONE & TELEGRAPH WORK - A.T.&T Long Lines Div. (1953)
- MEASUREMENT OF SELECTING MARGINS - W.J. Zenner (1937)
- FEDERAL AIRWAYS MANUAL OF OPERATIONS, Vol. IV Civil Aeronautics Adminis. (1944)
- TELETYPEWRITER TRAINING MATERIAL - A.T.&T. Co. (1947)

M28 KEYBOARD

FROM DEPRESSION OF KEYLEVER
TO TRIPPING OF CLUTCH

L-112

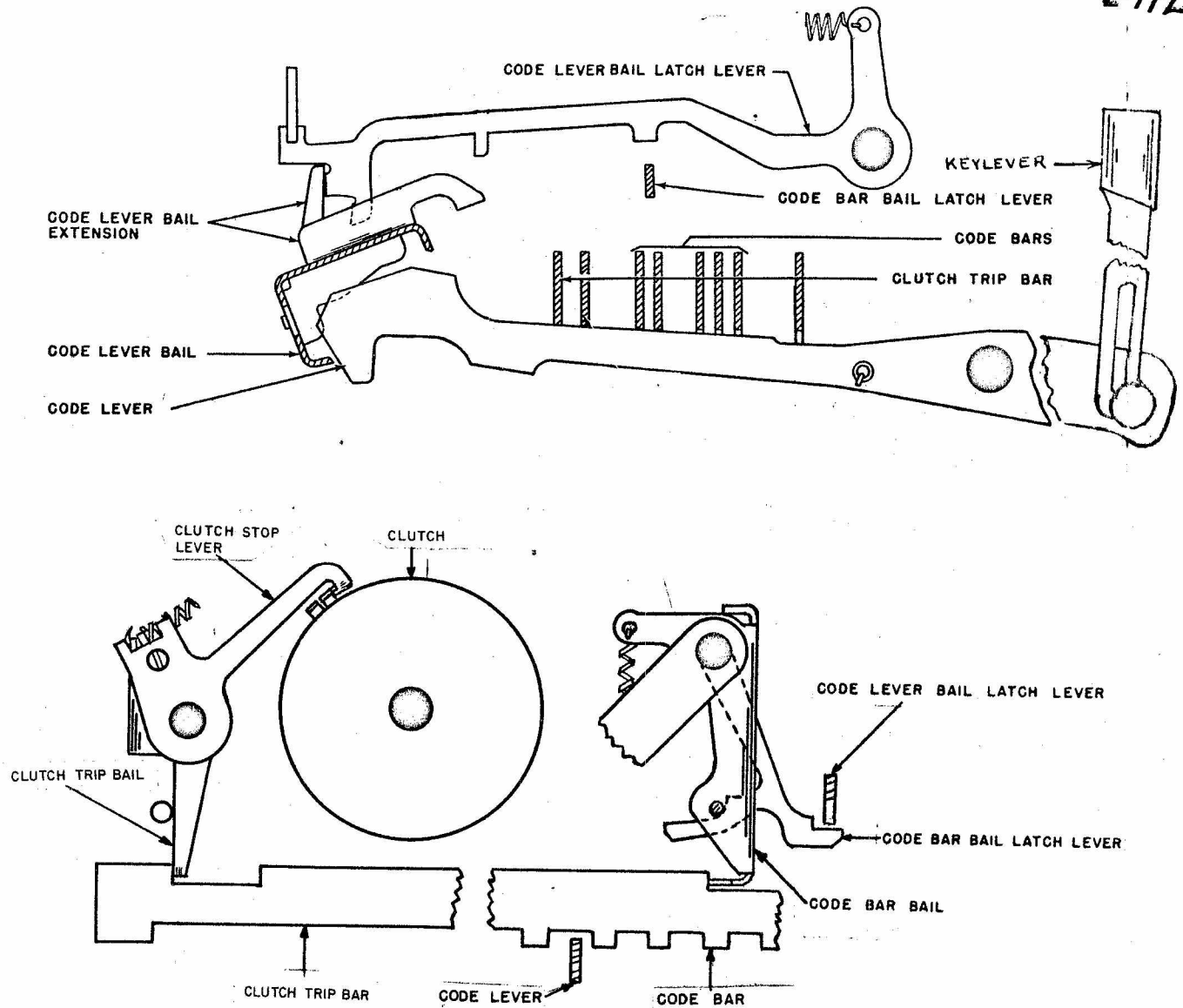

Depressing KEYLEVER moves

CODE LEVER rotates

CODE LEVER BAIL releases

CODE LEVER BAIL LATCH LEVER depresses

CODE BAR BAIL LATCH LEVER unlatches

CODE BAR BAIL releases

CODE BARS

(unselected code bars are
blocked by the operated
code lever)

CLUTCH TRIP BAR operates

CLUTCH TRIP BAIL and
CLUTCH STOP LEVER trips

CLUTCH and CAM SLEEVE rotates

M28 KEYBOARD

FROM TRIPPING OF CLUTCH
TO OPERATION OF CONTACT

L-113

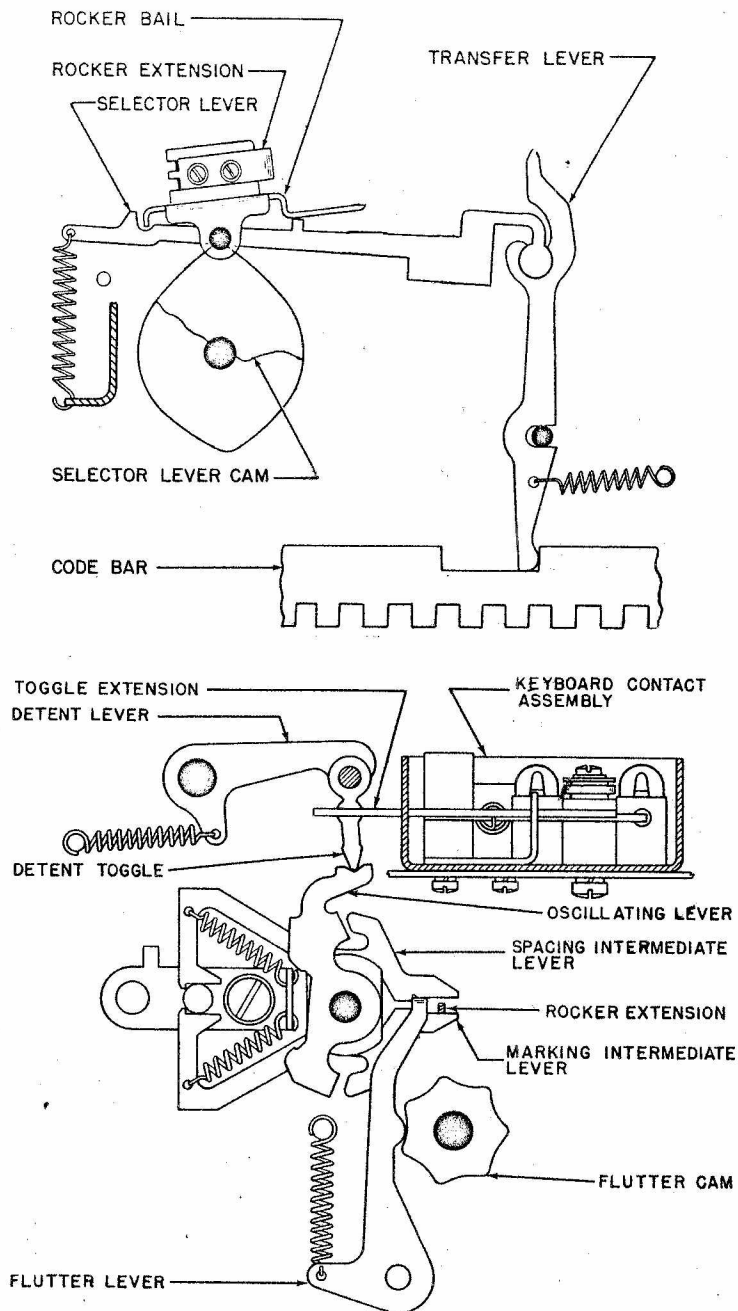

CODE BARS move

TRANSFER LEVERS move

CLUTCH trips and CAM SLEEVE rotates, raising

SELECTOR LEVERS actuate

ROCKER BAIL and ROCKER BAIL EXTENSION moves

unselected INTERMEDIATE LEVER out of the path of

FLUTTER LEVER drives

selected INTERMEDIATE LEVER rotates

OSCILLATOR LEVER moves

DETENT TOGGLE and TOGGLE EXTENSION to open
or close the signalling contact

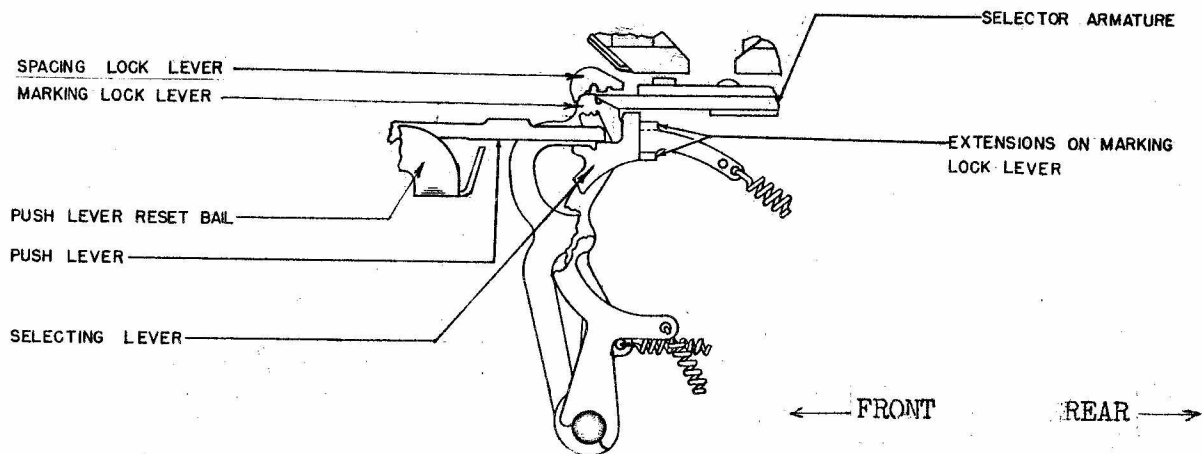
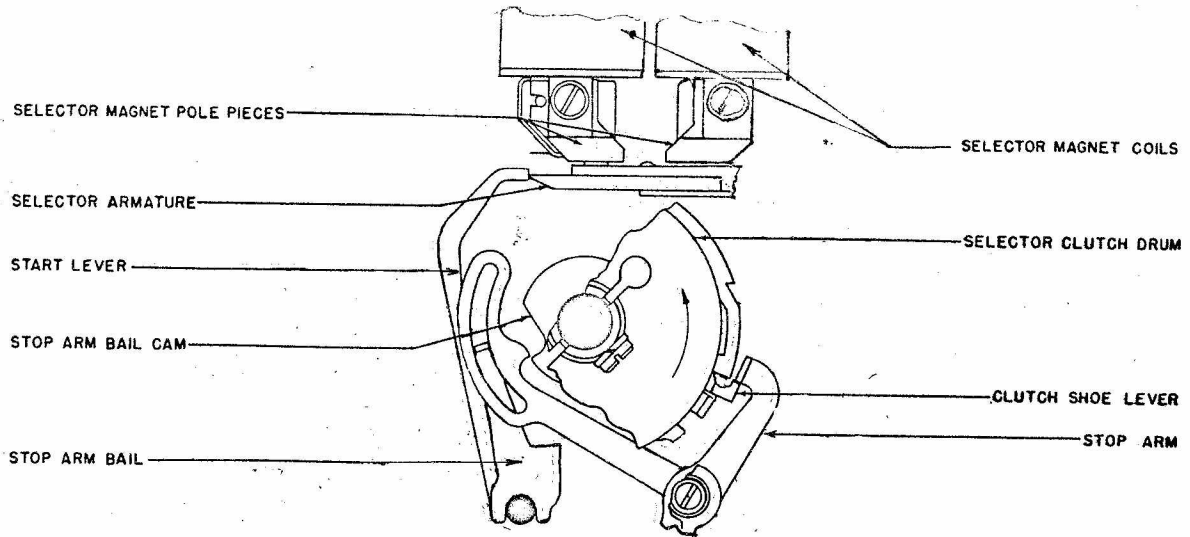

Start pulse received in SELECTOR MAGNET COILS releases
 ARMATURE unblocks
 START LEVER releases
 STOP ARM BAIL and STOP ARM
 CLUTCH trips and SELECTOR CAM SLEEVE rotates
 PUSH LEVER RESET BAIL resets
 PUSH LEVERS to the rear (spacing) position

ARMATURE attracted (marking) permits
 SELECTING LEVER to move behind
 PUSH LEVER drops down
 SELECTING LEVER moves
 PUSH LEVER forward to its marking
 position

ARMATURE unattracted (spacing) blocks
 MARKING LOCK LEVER
 MARKING LOCK LEVER EXTENSIONS block
 SELECTING LEVER causing PUSH LEVER to
 remain on top of SELECTING LEVER
 and to the rear in its spacing
 position

MOVEMENT OF THE START LEVER

1. The armature drops down for the first pulse, the START pulse, which is always SPACING. The Start lever drops over the armature extension, holding the armature spacing. The Start lever is connected to the Stop Arm Bail -- as the Start Lever moves over the armature extension, the Stop Arm Bail is forced into the indent of its cam -- causing the Selector Clutch Stop Arm (shown as one piece with the Bail, for illustration purposes) to fall away and allow the clutch to engage and begin rotating.
2. As the Selector cam begins rotating, the reverse action takes place. The Stop Arm Bail extension rides to the high part of the front cam, forcing the Start Lever clear of the armature extension and pulling the Selector Clutch Stop Arm back against the clutch drum where it will be in position to stop the Selector clutch after one revolution.

NOTE: Because the Stop Arm Bail Cam (Front Cam) has only one indent, the Start Lever may not fall over the armature again during the cycle.

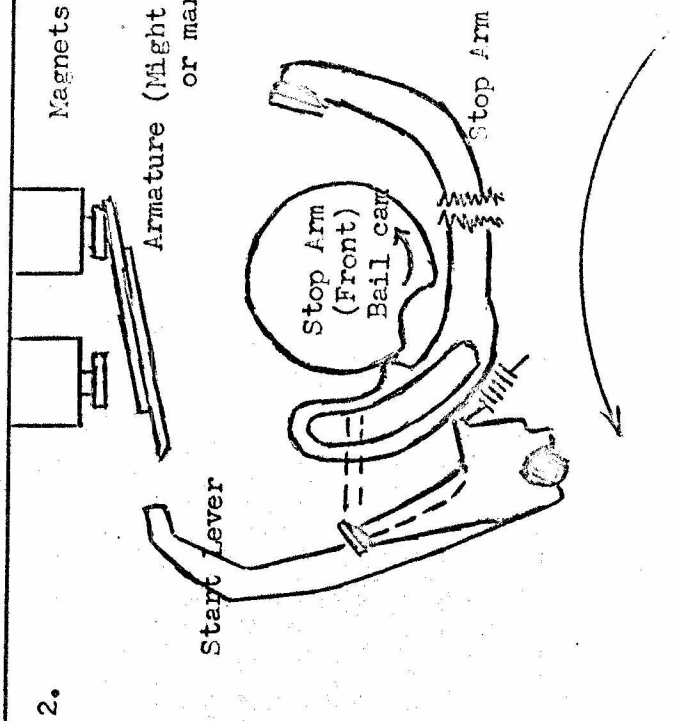
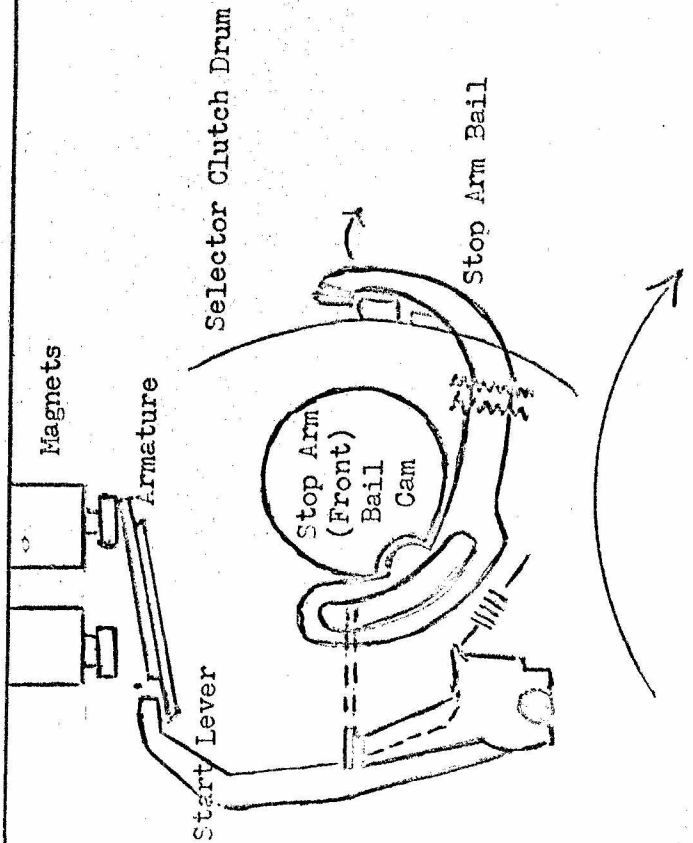
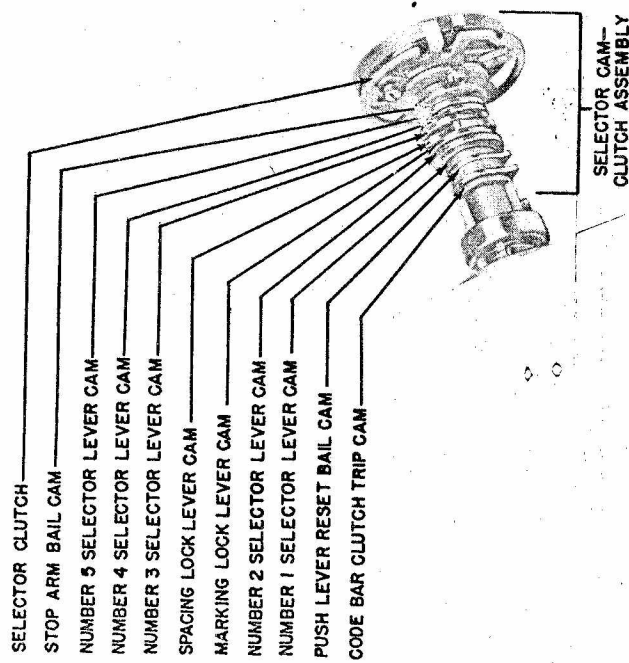

SELECTOR MECHANISM DURING SPACING IMPULSE

1. Magnets are de-energized and armature drops down. Spacing Lock Lever falls over top of armature, holding it spacing. Spacing Lock Lever rides into indent of double (LOCK) cam.
2. With the armature down (Spacing), the Marking Lock Lever is blocked. The projection on the Marking Lock Lever rides in the air over the indent in the double cam.
3. As the Selector cam indent comes into line, the Selector Lever attempts to move back into the indent. Because the Marking Lock Lever is being blocked by the armature extension (2), the Selector Lever is blocked by the arm on the Marking Lock Lever. The Push Lever moves forward, slightly, but not far enough to drop off onto the Selector Lever Guide.

Note: BETWEEN EACH PULSE, THE MARKING AND SPACING LOCK LEVERS RIDE TO A HIGH PART OF THE DOUBLE CAM AND MOVE CLEAR OF THE ARMATURE.

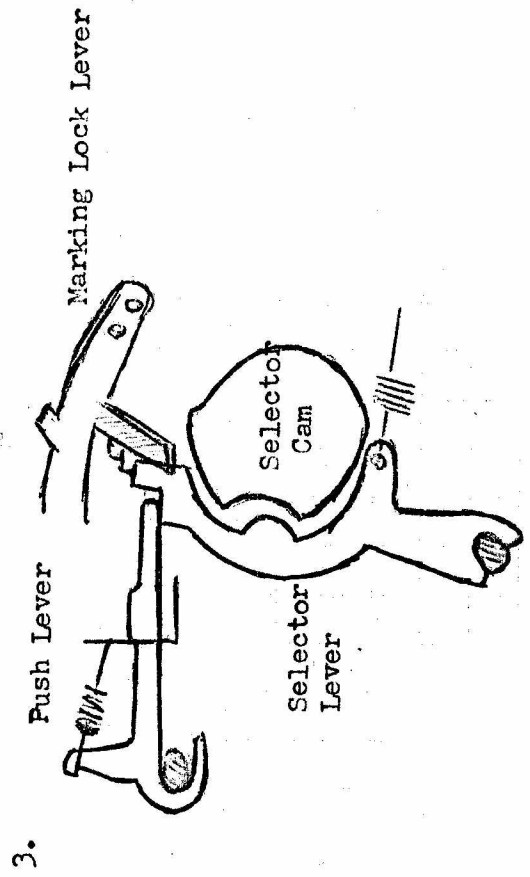
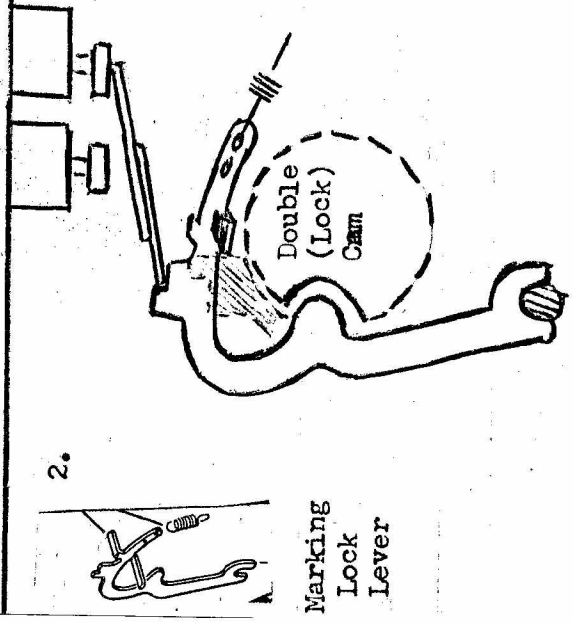
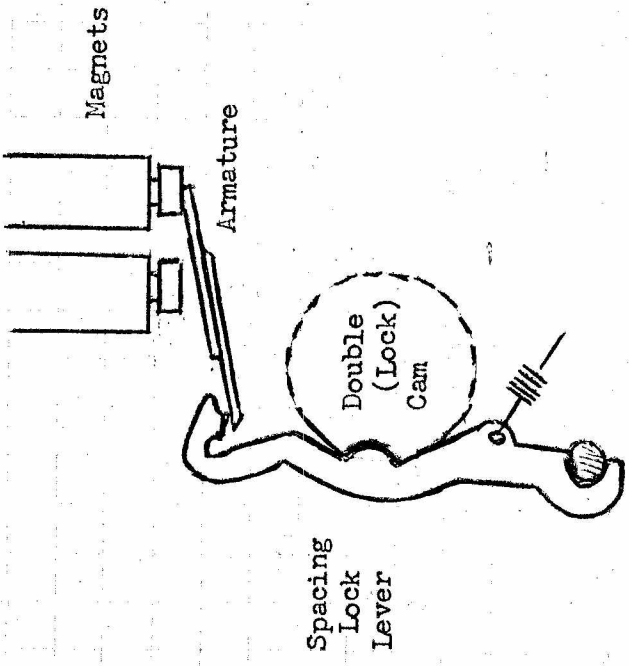

3.

SELECTOR MECHANISM DURING MARKING IMPULSE

1. Magnets are energized and armature is pulled up. The Spacing Lock Lever attempts to move to the rear but is now blocked by the armature extension.
 2. With the armature up (Marking), the Marking Lock Lever is free to be pulled to the rear by its spring. As it moves to the rear, it braces the armature against the pole pieces and rides into the indent of the double (Lock) cam. (The Spacing Lock Lever is, at this period, riding in the air above that same cam indent.)
 3. The Marking Lock Lever is now out of the way so the Selector Lever, which has the indent of its cam available, may fall in. The indents of the other Selector cams have either passed or not yet arrived, consequently only one Selector may fall in during any given pulse. Moving to the rear, the Selector Lever can no longer support the Push Lever and, consequently, the Push Lever drops down onto the Selector Lever Guide. As the Selector rides out of its indent it will move forward which, in turn, will cause the Push Lever to be moved forward.
- Note: BETWEEN EACH PULSE, THE MARKING AND SPACING LOCK LEVERS RIDE TO A HIGH PART OF THE DOUBLE CAM AND MOVE CLEAR OF THE ARMATURE EXTENSION.

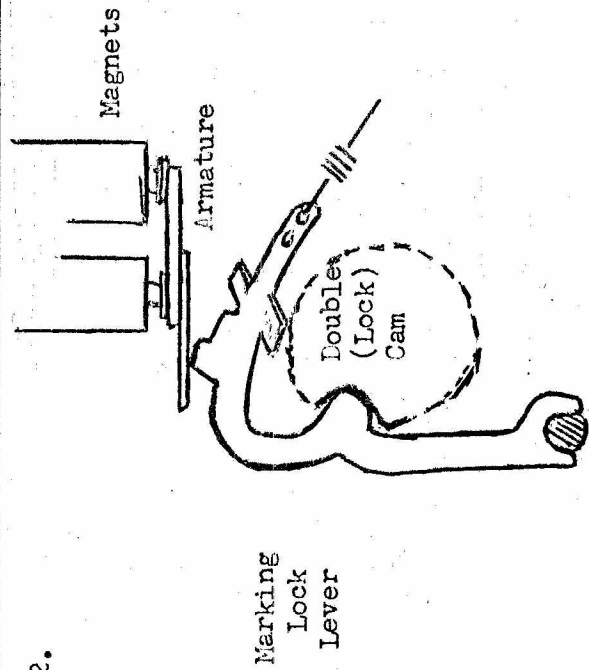
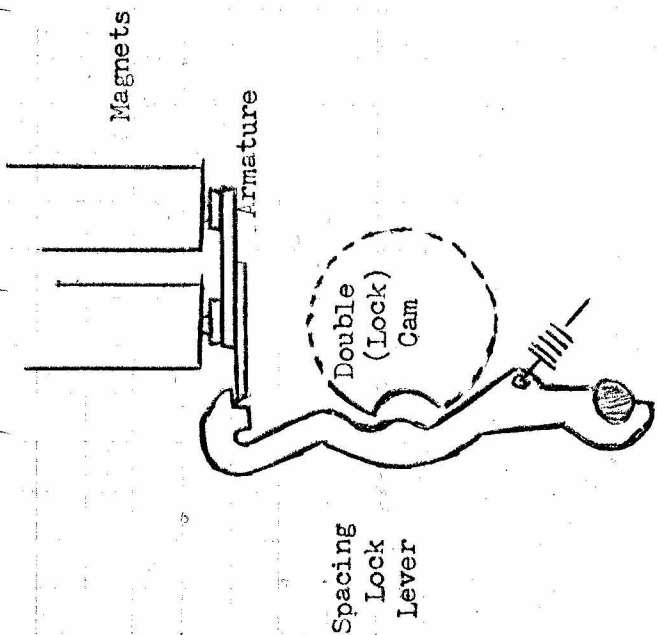

3.

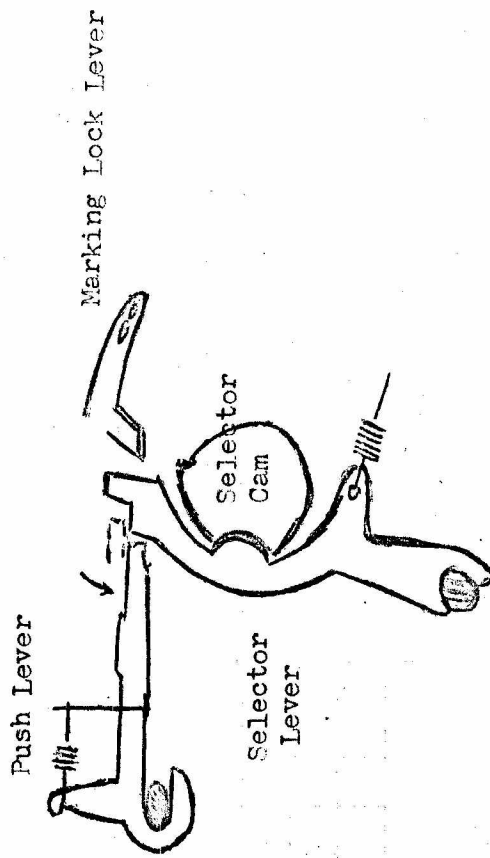

M28 PRINTER

L-118

CODE BAR POSITIONING MECHANISM

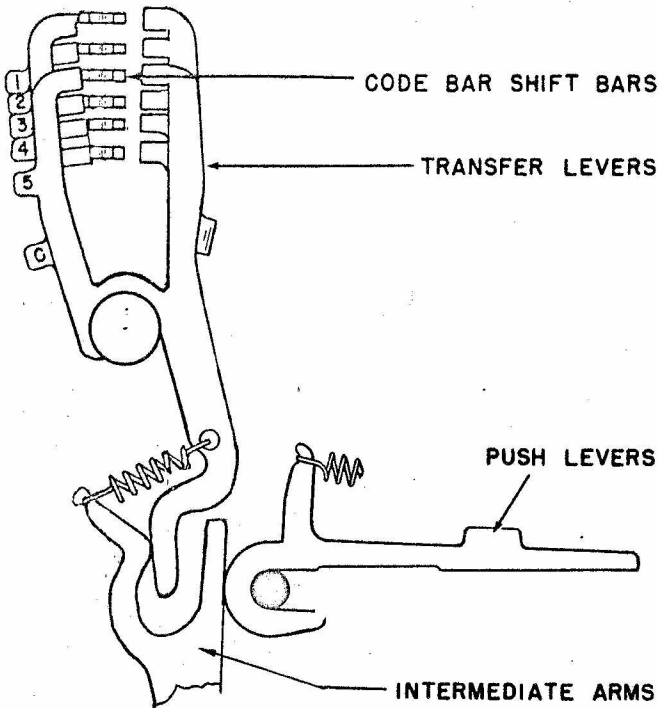

PUSH LEVERS operate

INTERMEDIATE ARMS operate

TRANSFER LEVER SPRINGS and
TRANSFER LEVERS to hold

CODE BAR SHIFT BARS against
marking (rear) or
spacing (front)
CODE BAR SHIFT LEVERS

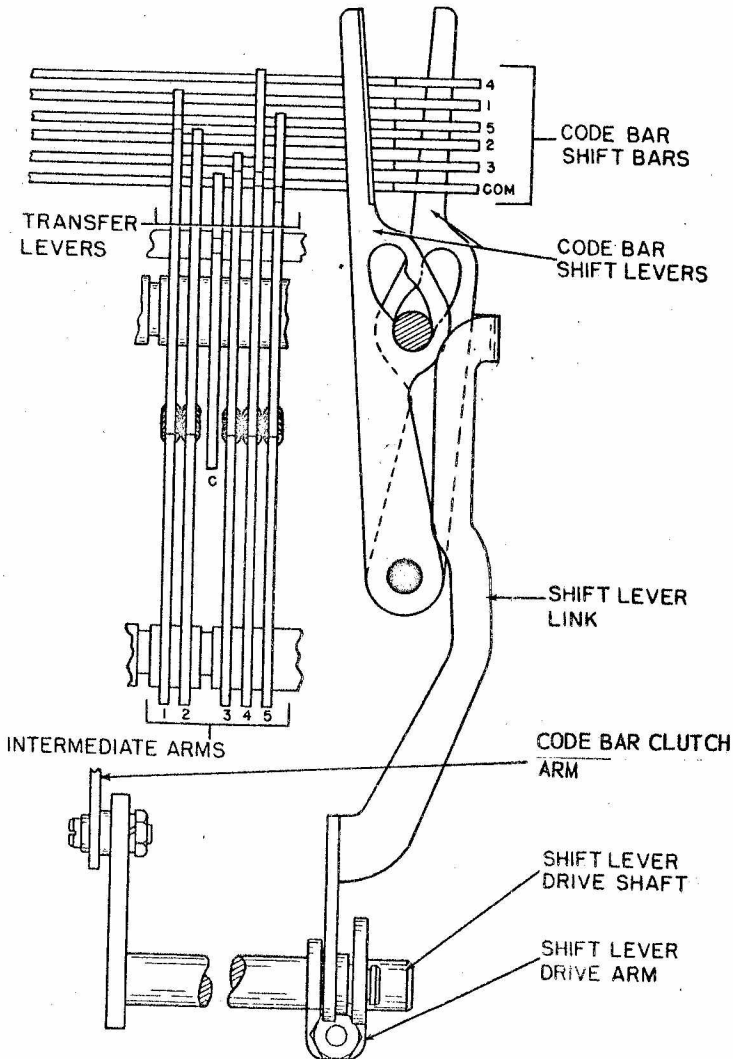

then,

SELECTOR CAM SLEEVE operates

CODE BAR CLUTCH TRIP LEVER ARM
which trips

CODE BAR CLUTCH drives

SHIFT LEVER DRIVE SHAFT,
SHIFT LEVER DRIVE ARM, and
SHIFT LEVER DRIVE LINK cams

CODE BAR SHIFT LEVERS position

CODE BAR SHIFT BARS and
CODE BARS to the left (marking)
or to the right (spacing)

M28 PRINTER

L-119

VERTICAL POSITIONING OF THE TYPE BOX

		LEFT				RIGHT			
		4 8 5 MARKING	4 MARKING 5 SPACING	4 SPACING 5 MARKING	4 8 5 SPACING	4 8 5 SPACING	4 SPACING 5 MARKING	4 MARKING 5 SPACING	4 8 5 MARKING
LOWERMOST CODE BAR									
COMM	TOP ROW	M -- 3 4 5	N -- 3 4 --	H -- 3 - 5	SPACE -- 3 --	BLANK -----	T ----- 5	C. R. -- 4 --	O -- 4 5
2	2ND ROW	X 3 4 5	F 3 4 --	Y 3 - 5	S 3 --	E -----	Z ----- 5	D -- 4 --	B -- 4 5
1	3RD ROW	V - 2 3 4 5	C - 2 3 4 --	P - 2 3 - 5	I - 2 3 --	L.F. - 2 -----	L - 2 ----- 5	R - 2 - 4 --	G - 2 - 4 5
SUPP	BOTTOM ROW	LETTERS 2 3 4 5	K 2 3 4 --	Q 2 3 - 5	U 2 3 --	A 2 -----	W 2 -- 5	J 2 - 4 --	FIGURES 2 - 4 5
		3 MARKING				3 SPACING			
		4TH ROW	3RD ROW	2ND ROW	1ST ROW	1ST ROW	2ND ROW	3RD ROW	4TH ROW

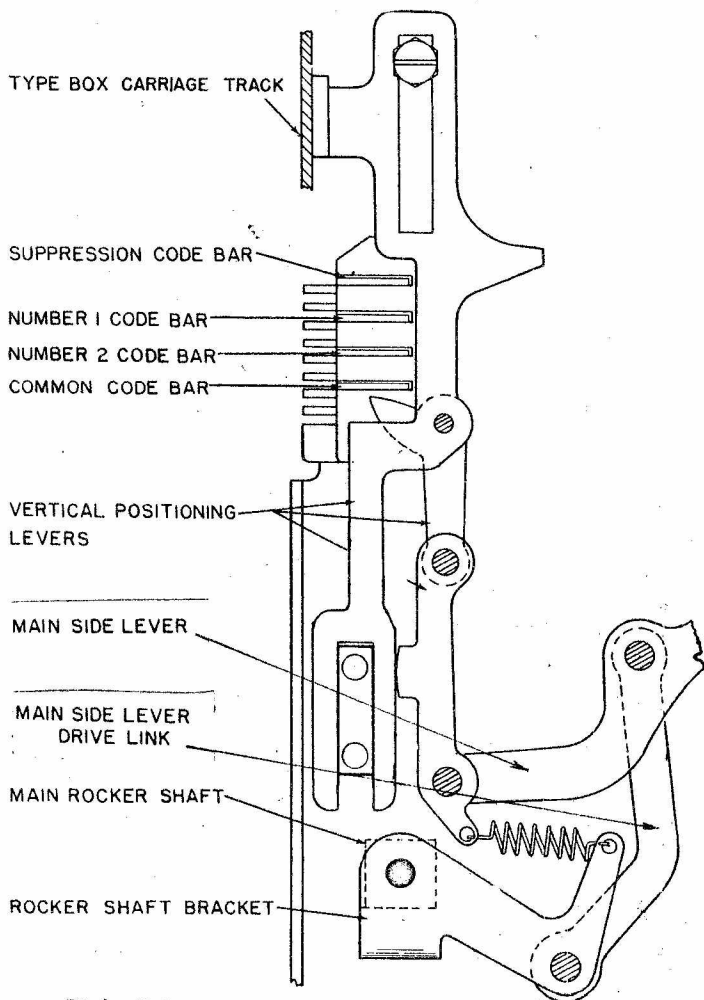

Right Side Mechanism

As the code bar clutch rotates, a cam follower actuates the clutch trip lever shaft which trips off both the function clutch and the type box clutch.

TYPE BOX CLUTCH, through a drive link and the left rocker shaft bracket, rotates the

ROCKER SHAFT and the right rocker shaft bracket

ROCKER SHAFT BRACKETS drive

MAIN SIDE LEVER DRIVE LINKS move

MAIN SIDE LEVERS move

VERTICAL POSITIONING LEVERS raise

TYPE BOX CARRIAGE TRACK and TYPE BOX

VERTICAL POSITIONING LEVER TOE buckles against lowermost CODE BAR in its path to select printing level of type box.

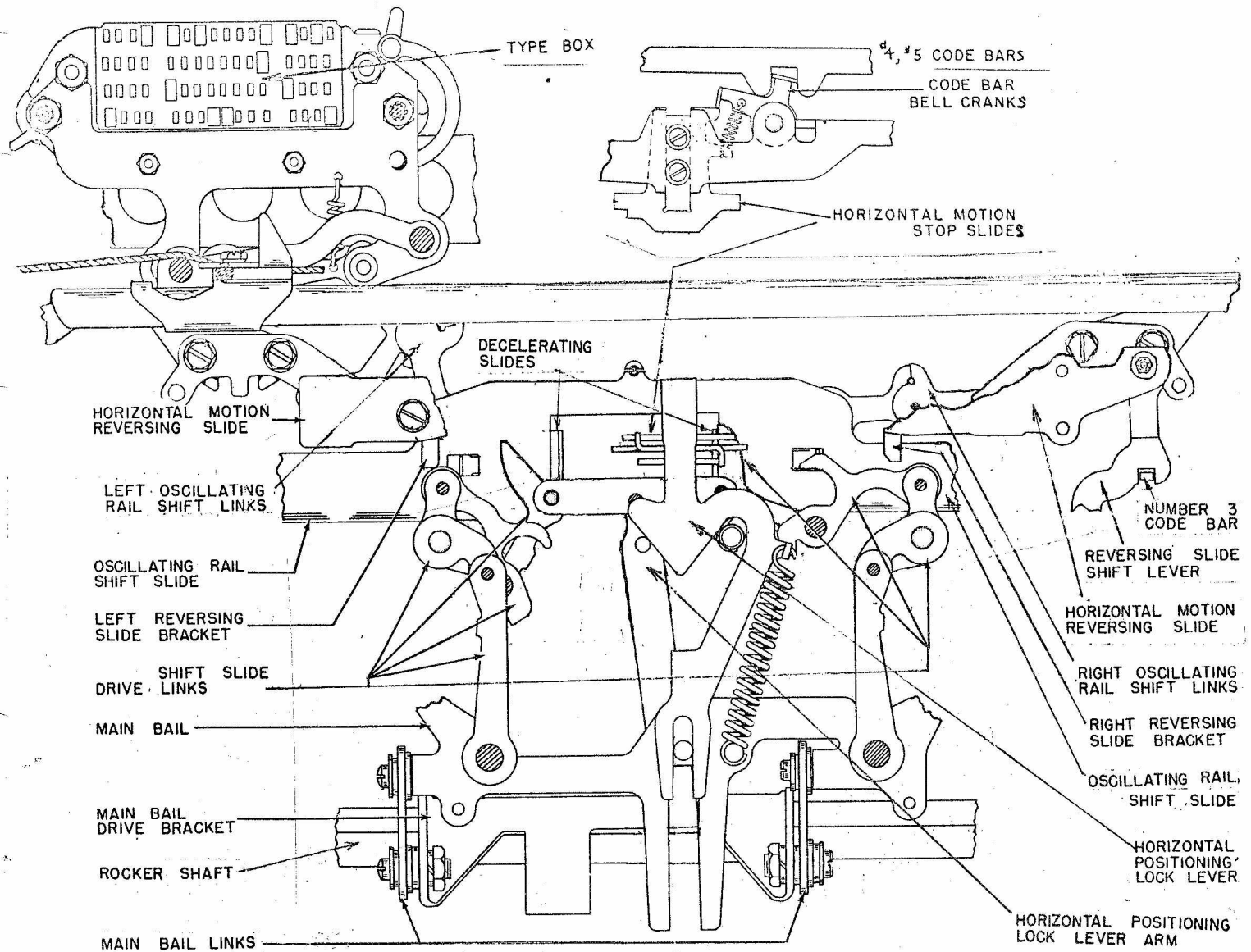

The #4 and #5 CODE BARS through the CODE BAR BELL CRANKS control the HORIZONTAL STOP SLIDES

The #3 CODE BAR, through the REVERSING SLIDE SHIFT LEVER, the REVERSING SLIDE and the REVERSING SLIDE BRACKETS will disable the LEFT SHIFT SLIDE DRIVE LINK when the #3 code bar is spacing, and will disable the RIGHT SHIFT SLIDE DRIVE LINK when the #3 code bar is marking.

As the TYPE BOX CLUTCH rotates, the ROCKER SHAFT, moves the MAIN BAIL DRIVE BRACKET and the MAIN BAIL LINKS to pull the MAIN BAIL down. The undisabled SHIFT SLIDE DRIVE LINK, through its DECELERATING SLIDE, initiates the motion of the OSCILLATING RAIL SHIFT SLIDE. This motion is completed by the HORIZONTAL POSITIONING LOCK LEVER which through its LOCK LEVER ARM moves the OSCILLATING RAIL SHIFT SLIDE against the longest of the HORIZONTAL STOP SLIDES in its path. The OSCILLATING RAIL SHIFT SLIDE drives the OSCILLATING RAIL SHIFT LINKS and the OSCILLATING RAIL to move the TYPE BOX horizontally to its selected printing row.

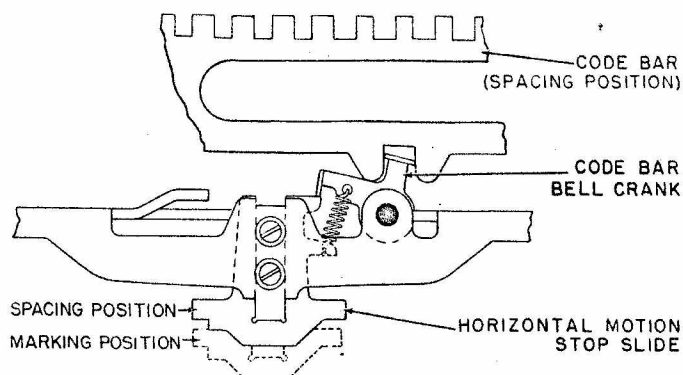
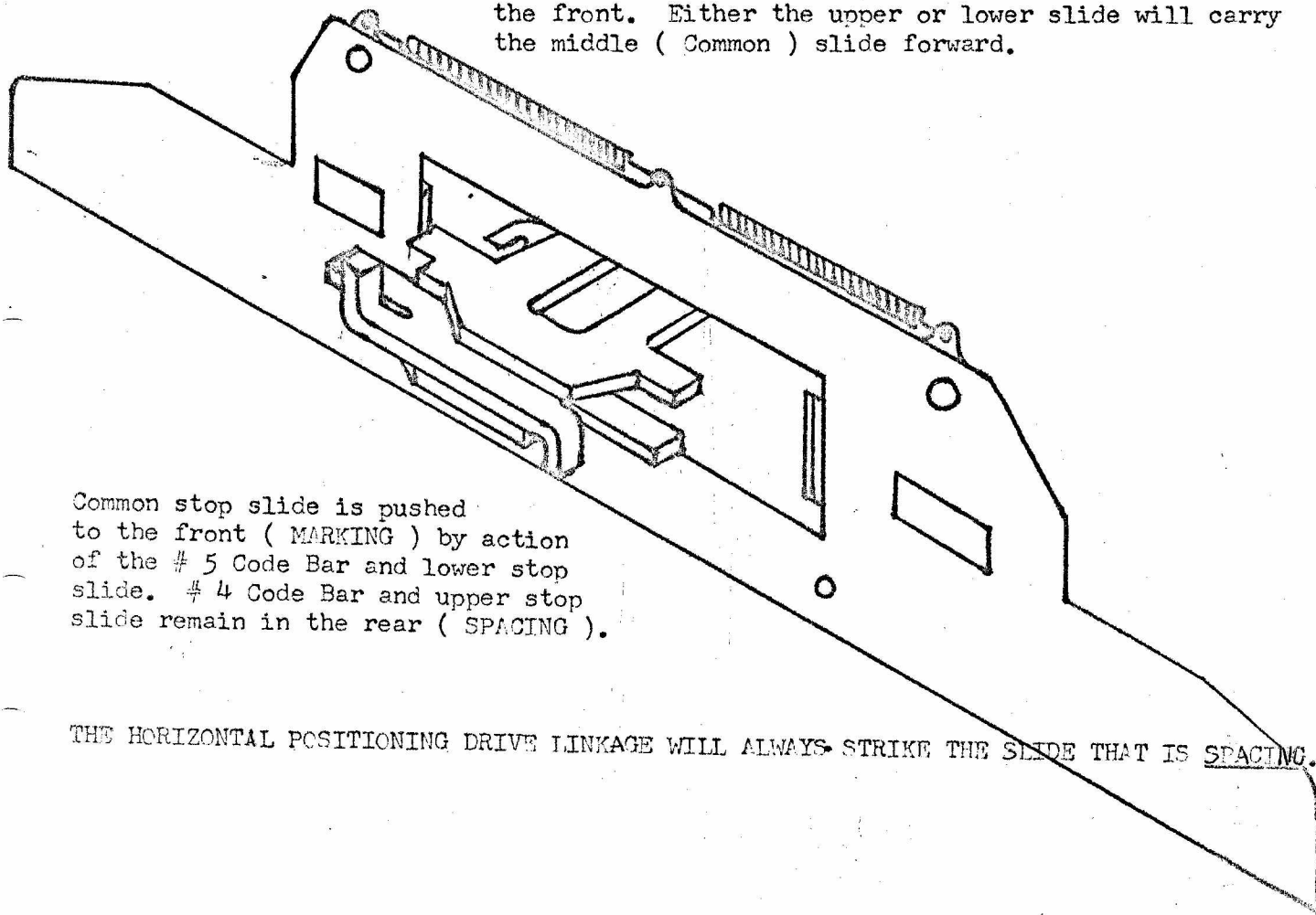

FIGURE 2-48. STOP SLIDE POSITIONING

View, looking down, of the relationship between the horizontal stop slides and the code bars which position them. The middle, or Common stop slide, DOES NOT HAVE A CODE BAR ASSOCIATED WITH IT. It is merely spring loaded to the rear (SPACING) Movement of the code bar to the left (MARKING) causes the bell crank to push the associated slide to the front. Either the upper or lower slide will carry the middle (Common) slide forward.



Common stop slide is pushed to the front (MARKING) by action of the # 5 Code Bar and lower stop slide. # 4 Code Bar and upper stop slide remain in the rear (SPACING).

THE HORIZONTAL POSITIONING DRIVE LINKAGE WILL ALWAYS STRIKE THE SLIDE THAT IS SPACING.

- 1.) #3 Code Bar SPACING, Left linkage partially buckled.
 #4 & #5 Code bar, upper & lower horizontal stop slides and common stop slide SPACING.

The horizontal linkage drives to the LEFT, moving the typebox to the left. Linkage strikes the SHOULDER of the common horizontal stop slide. The linkage has traveled the LEAST distance and, consequently the hammer will strike in the first row to the right of center.

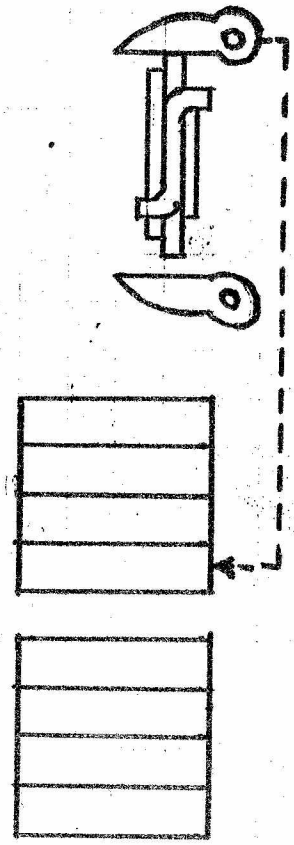

- 2.) #3 Code Bar SPACING, Left linkage partially buckled.
 #4 " " " Upper stop slide in rear
 #5 " " MARKING, Lower & common slides to front.

The horizontal linkage drives to the LEFT, moving the typebox to the left. Linkage strikes the SHOULDER of the Upper slide. The linkage has traveled to its second stop and, consequently, the hammer will strike in the second row to the right of center.

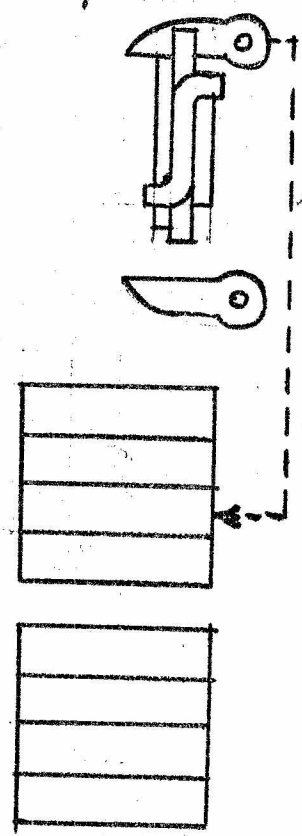

- 3.) #3 Code Bar MARKING, Right linkage partially buckled.
 #4 " " " Upper & middle slides to front
 #5 " " SPACING, Lower slide to rear

The horizontal linkage drives to the RIGHT, moving the typebox to the right. Linkage strikes the SHOULDER of the Lower stop slide. The linkage has traveled to its third stop and, consequently, the hammer will strike three rows to the left of center.

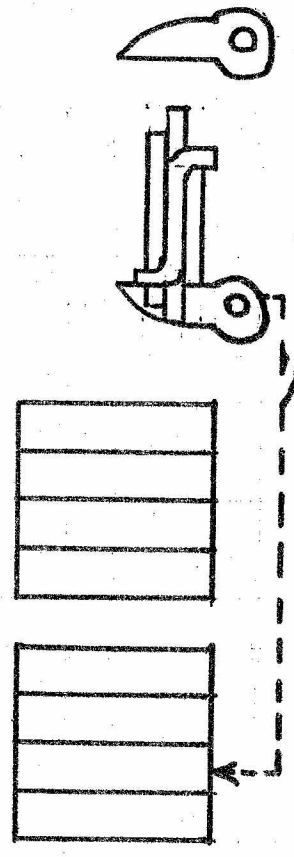

- 4.) #3 Code Bar MARKING, Right linkage partially buckled.
 #4 " " " Upper slide to front
 #5 " " " Lower & common slide to front.

The horizontal linkage drives to the RIGHT, moving the typebox to the right. Linkage strikes the SHANK of the common stop slide. The linkage has traveled to its fourth stop and, consequently, the hammer will strike four rows to the left of center.

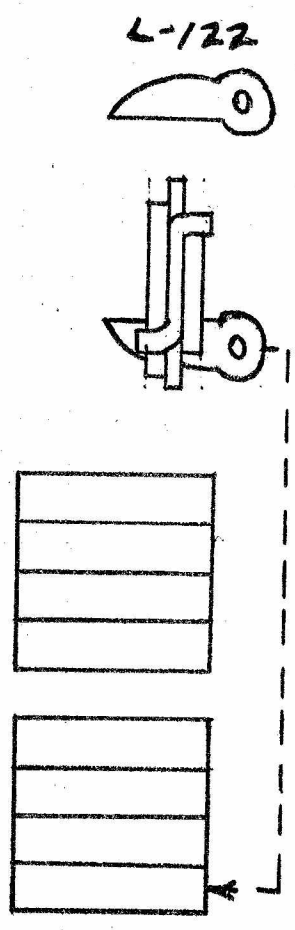

L-122

M28 PRINTER

PRINTING MECHANISM

L-123

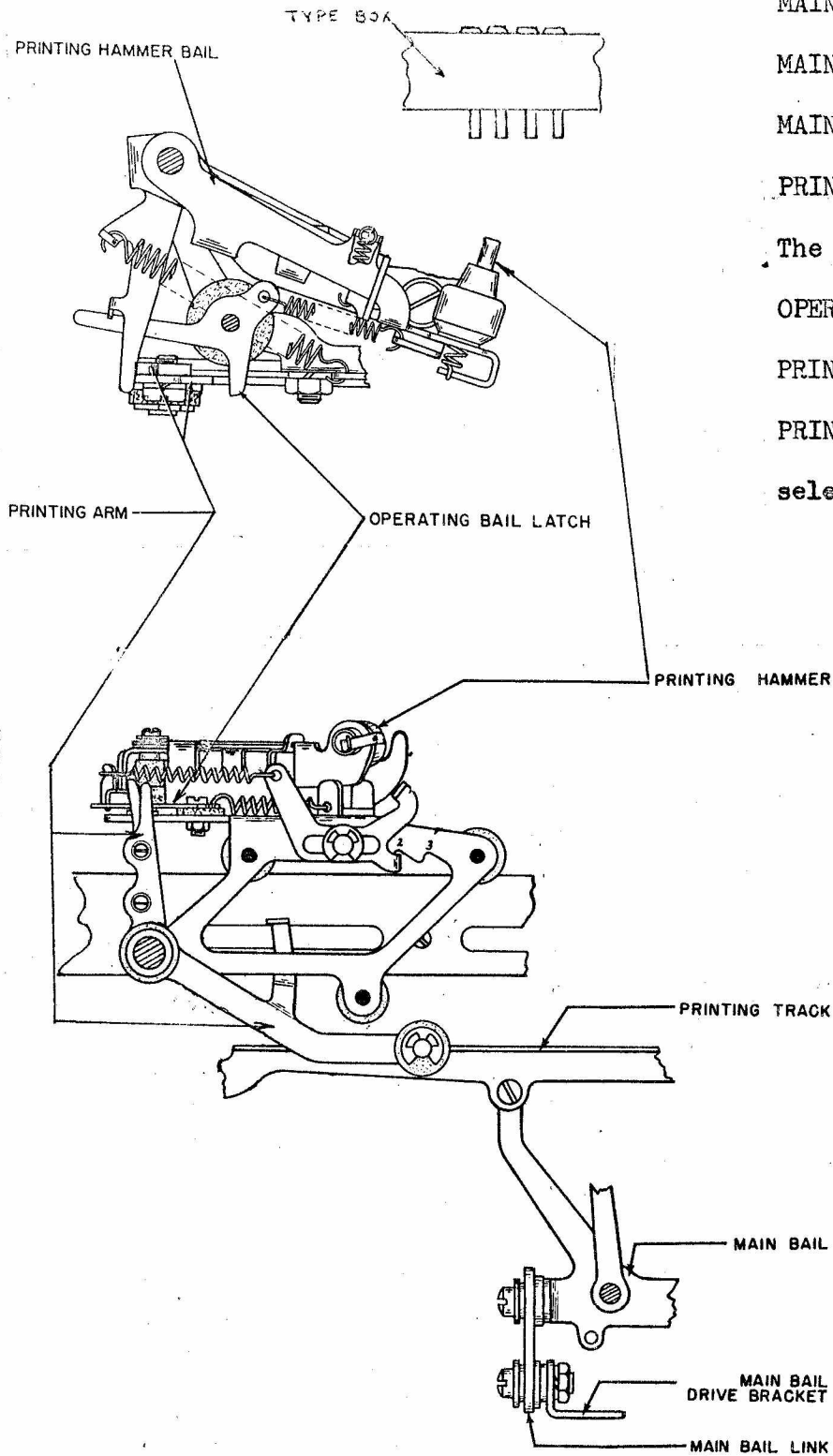

As the TYPE BOX CLUTCH rotates, the
ROCKER SHAFT moves the
MAIN BAIL DRIVE BRACKET,
MAIN BAIL LINKS,
MAIN BAIL, and the
PRINTING TRACK downward.

The PRINTING ARM actuates the
OPERATING BAIL LATCH to unlatch the
PRINTING HAMMER BAIL and
PRINTING HAMMER which strikes the
selected TYPE PALLET.

M28 PRINTER

L-124

SPACING MECHANISM

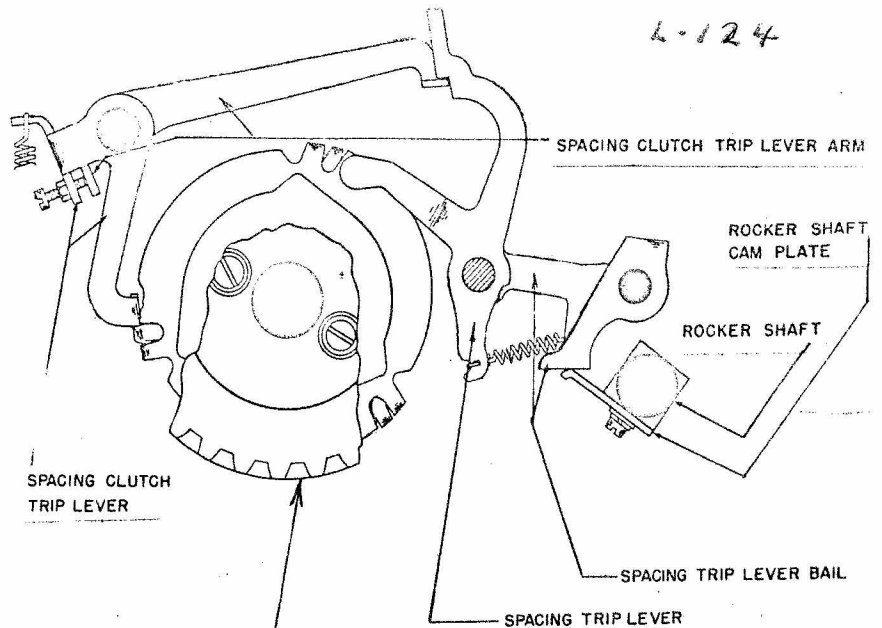

As the TYPE BOX CLUTCH rotates, the
ROCKER SHAFT and the
ROCKER SHAFT CAM PLATE actuate the
SPACING TRIP LEVER BAIL moves the
SPACING TRIP LEVER past the
SPACING CLUTCH TRIP LEVER ARM.
SPACING TRIP LEVER BAIL SPRING move
SPACING TRIP LEVER moves
SPACING CLUTCH TRIP LEVER ARM move
SPACING CLUTCH TRIP LEVER trips
SPACING CLUTCH rotates
SPACING SHAFT DRIVING GEAR drives
SPACING SHAFT DRIVEN GEAR rotates
SPACING ECCENTRICS drive
SPACING DRUM FEED PAWLS advance
SPACING DRUM rotates

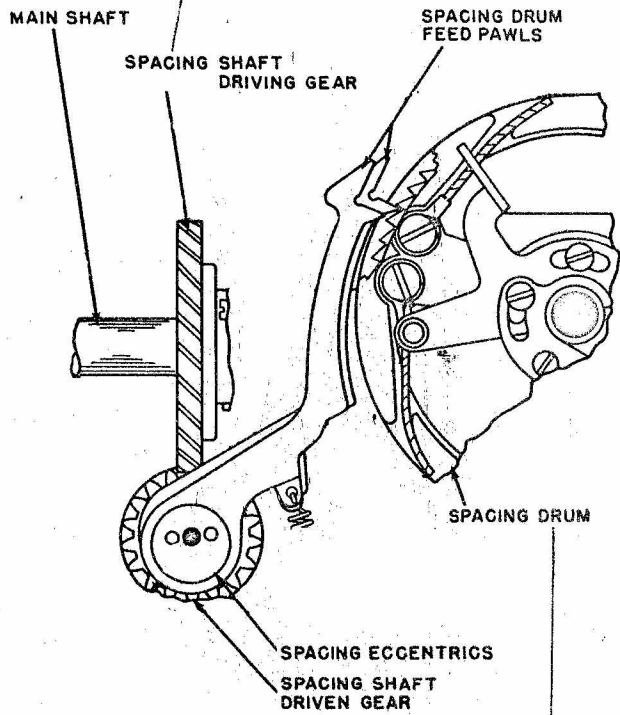

DRAW WIRE ROPE MECHANISM to space
the PRINTING CARRIAGE and the
TYPE BOX CARRIAGE.

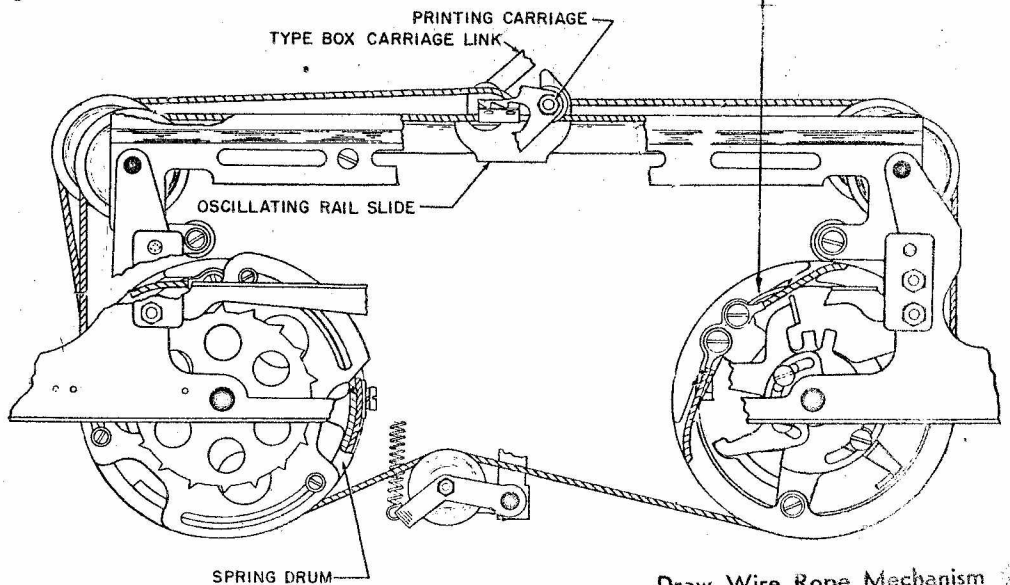

Draw Wire Rope Mechanism

← front rear →

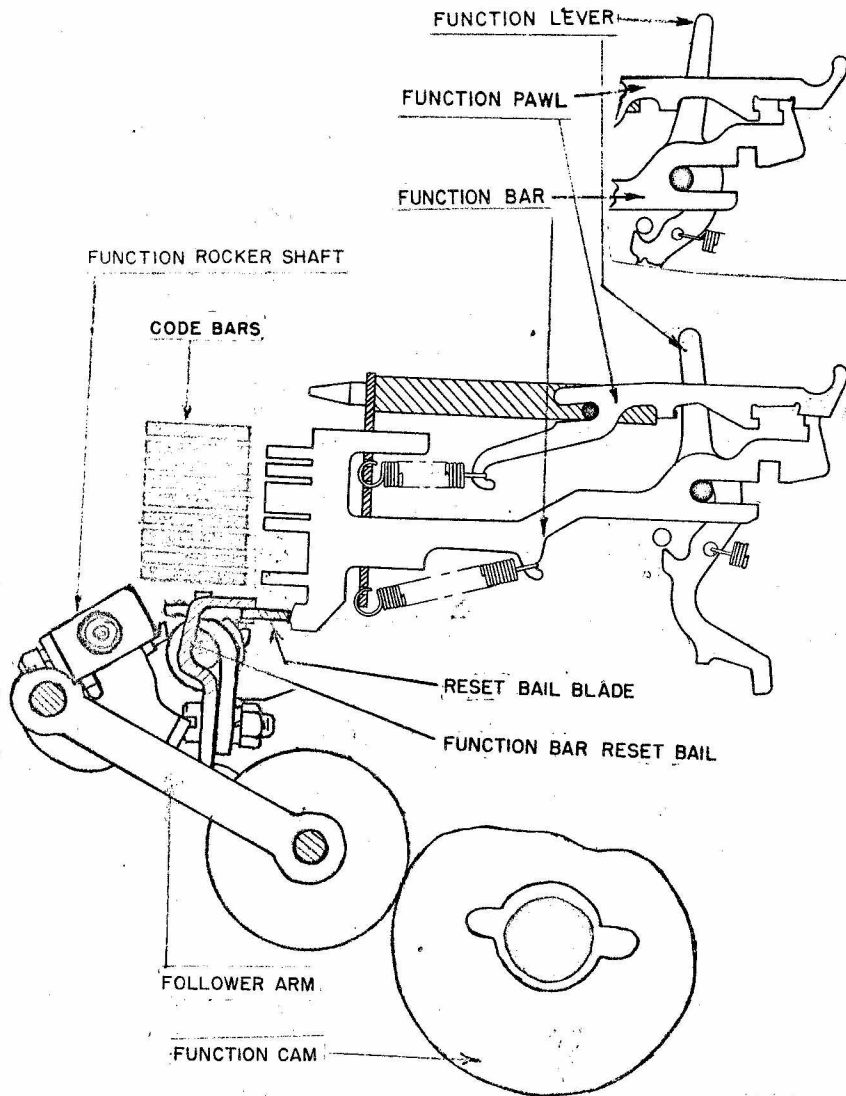

function bar selected

function bar unselected

As the code bar clutch rotates, through its cam follower and the clutch trip shaft, the type box clutch and the function clutch are tripped off.

FUNCTION CLUTCH and FUNCTION CAM operate

FUNCTION ROCKER SHAFT cams

FUNCTION BAR RESET BAIL and RESET BAIL BLADE withdraw to let

FUNCTION BARS sense

CODE BARS block UNSELECTED FUNCTION BARS but unblock

SELECTED FUNCTION BAR moves forward to let

FUNCTION PAWL drop over rear of

SELECTED FUNCTION BAR

RESET BAIL BLADE moves to the rear to operate

SELECTED FUNCTION BAR moves

FUNCTION PAWL moves

FUNCTION LEVER actuates associated

FUNCTION MECHANISM or CONTACT

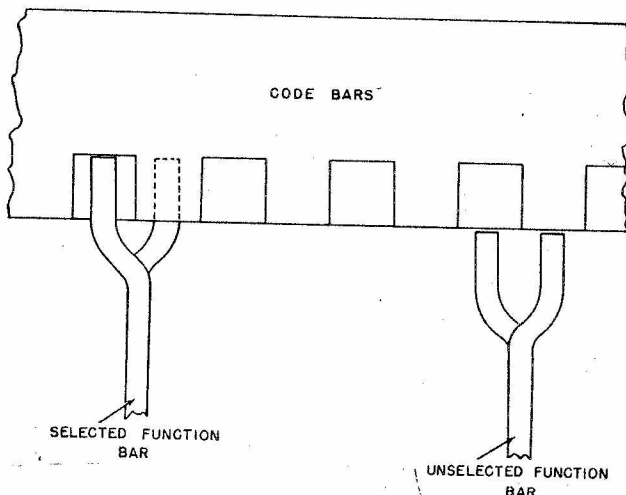

SECTION P70.035

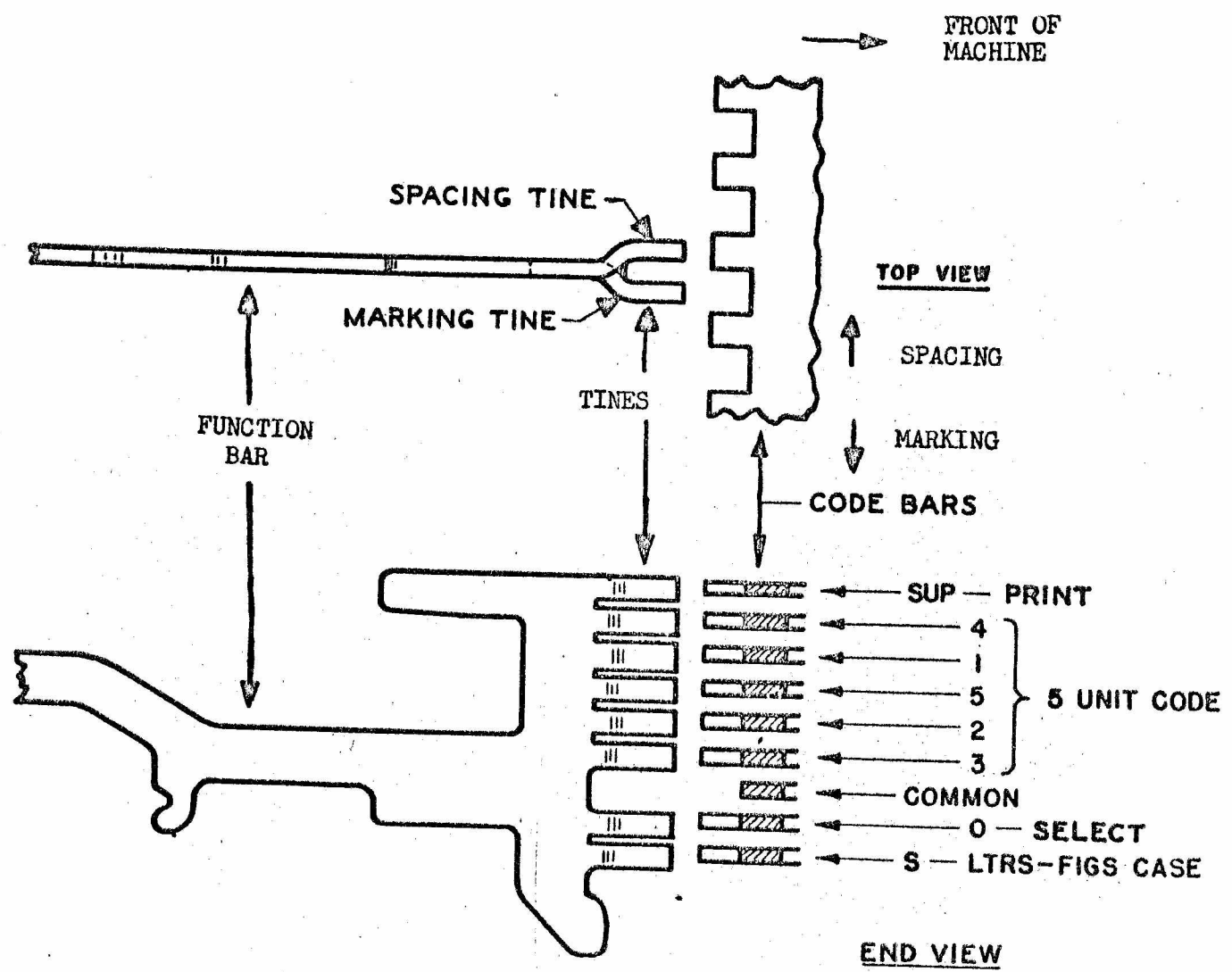

EACH TINE MAY BE FORMED TO PERMIT OPTIONAL SELECTION WHEN THE ASSOCIATED CODE BAR IS TOWARD THE LEFT (MARKING) OR RIGHT (SPACING). SELECTION IS PERMITTED IN EITHER CASE IF THE TINE IS OMITTED.

Fig. 3 - Function Bar

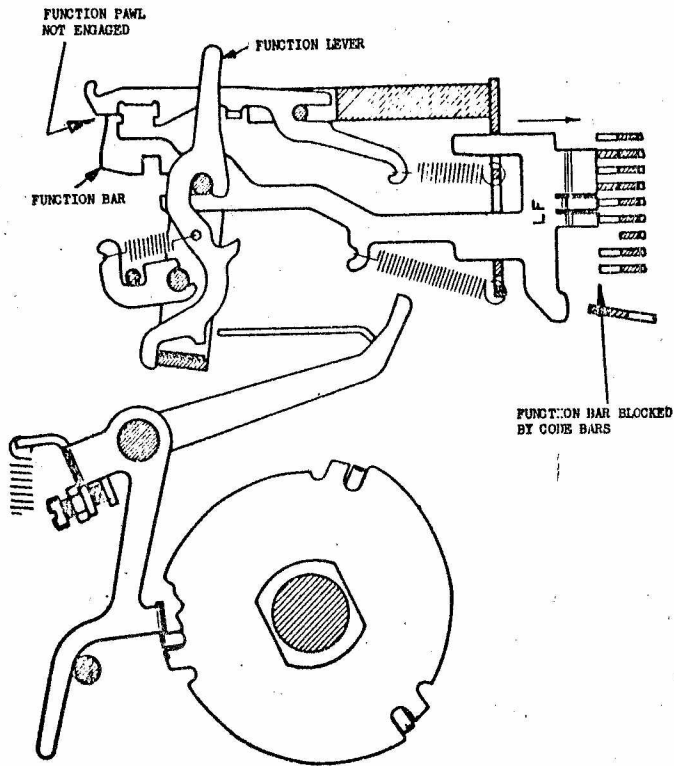

FIG. 1 - Operation of a Printer Function

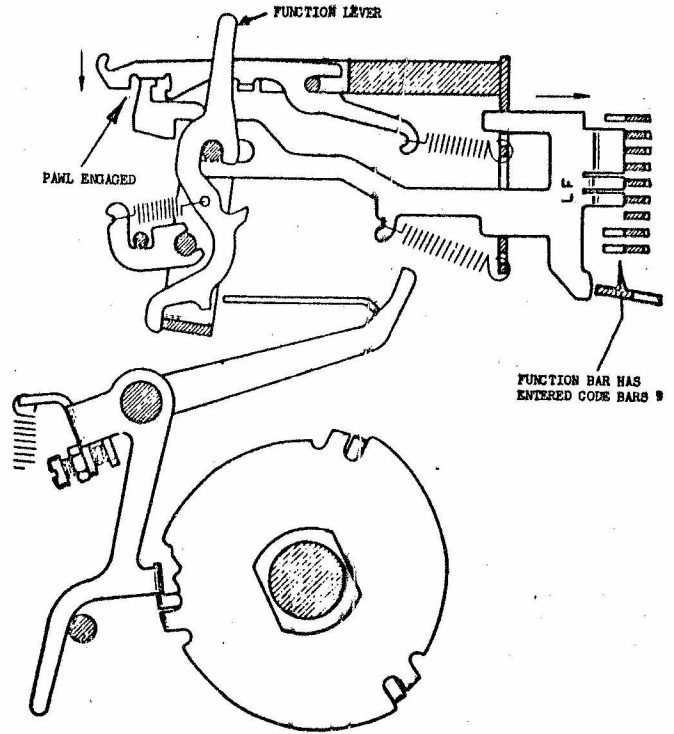

FIG. 2 - Operation of a Printer Function

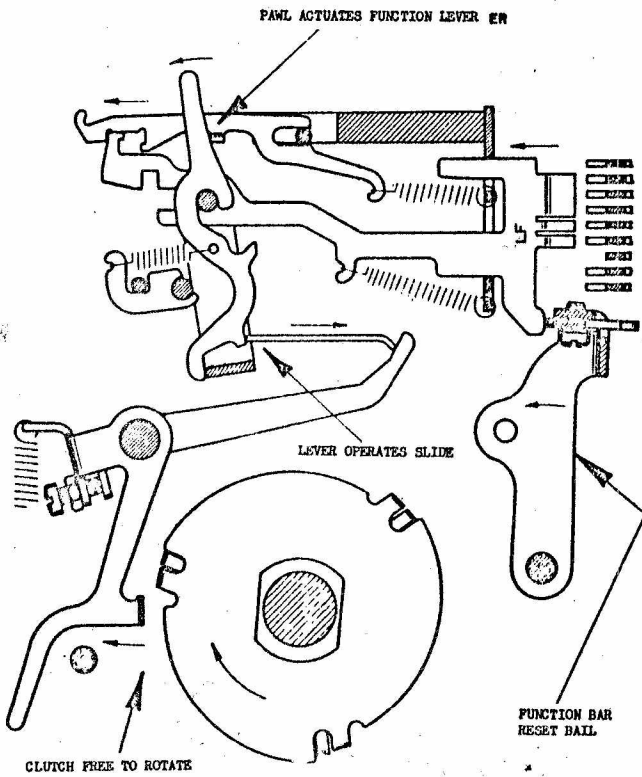

FIG. 3 - Operation of a Printer Function

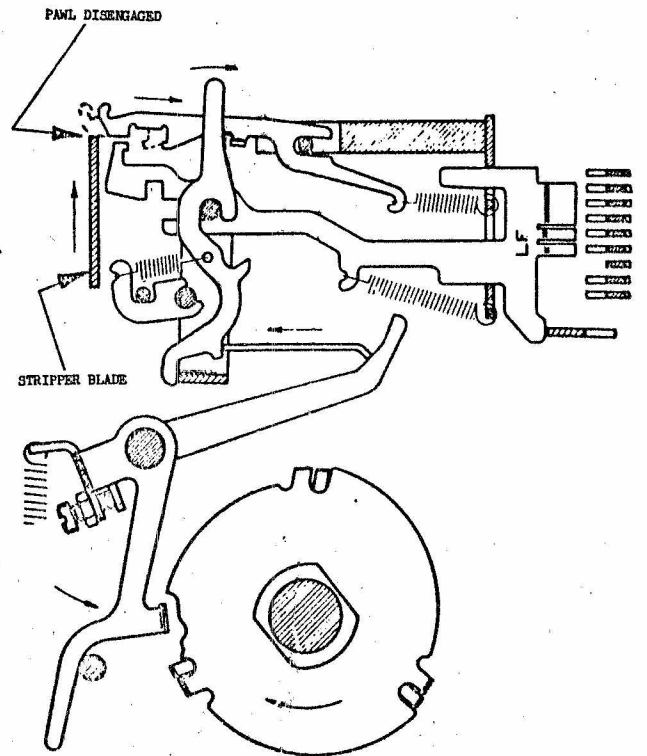
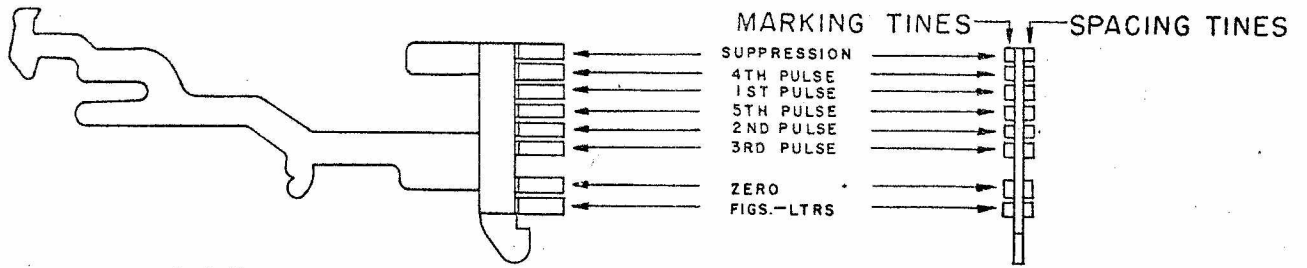

FIG. 4 - Operation of a Printer Function

UNIVERSAL FUNCTION BAR 153440

L-128



SIDE VIEW

FRONT VIEW

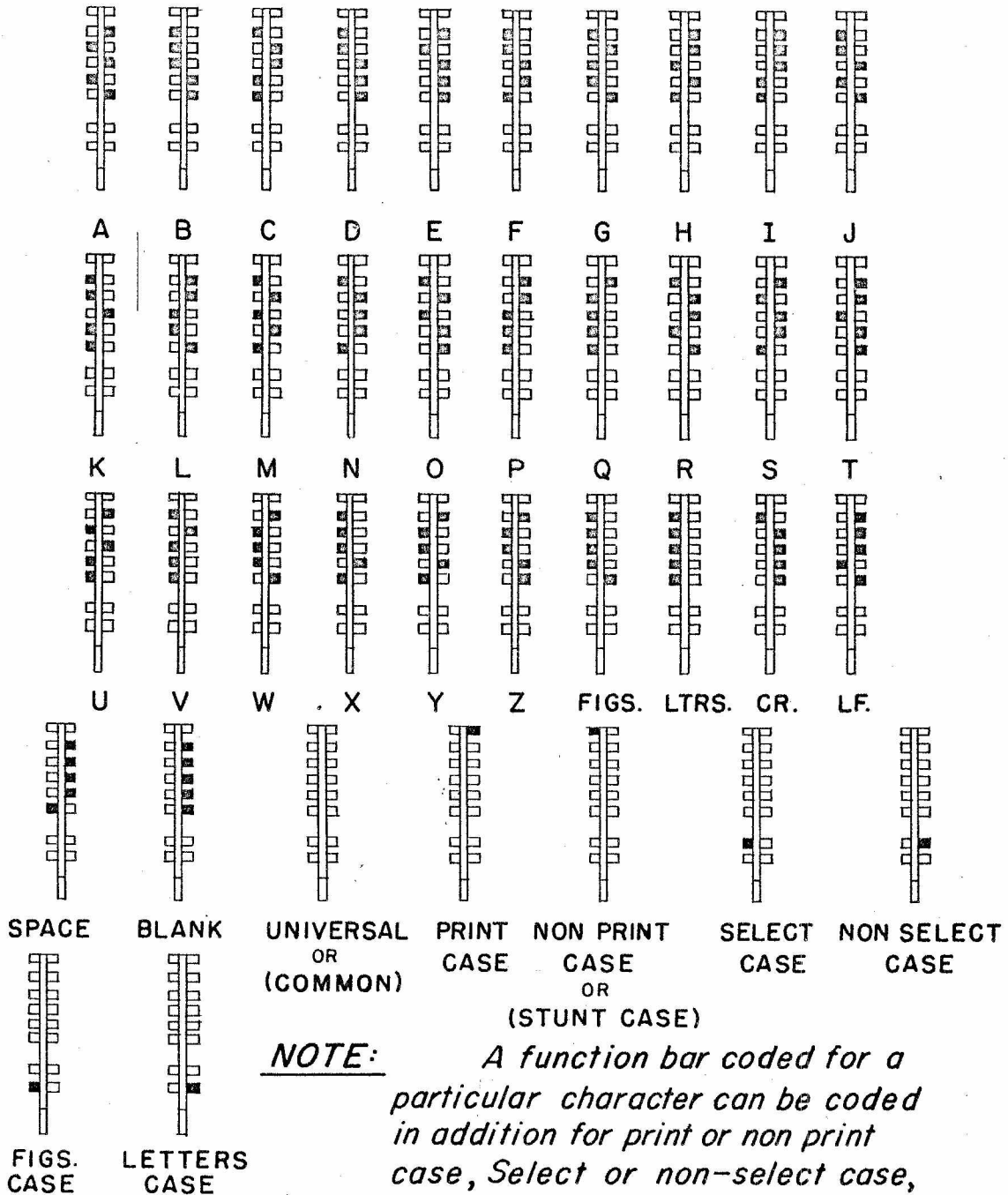

NOTE:

A function bar coded for a particular character can be coded in addition for print or non print case, Select or non-select case, Figs. or Ltrs. Case, or any combination thereof.

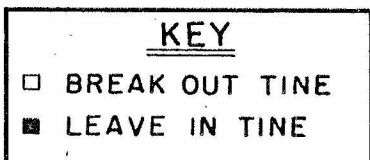

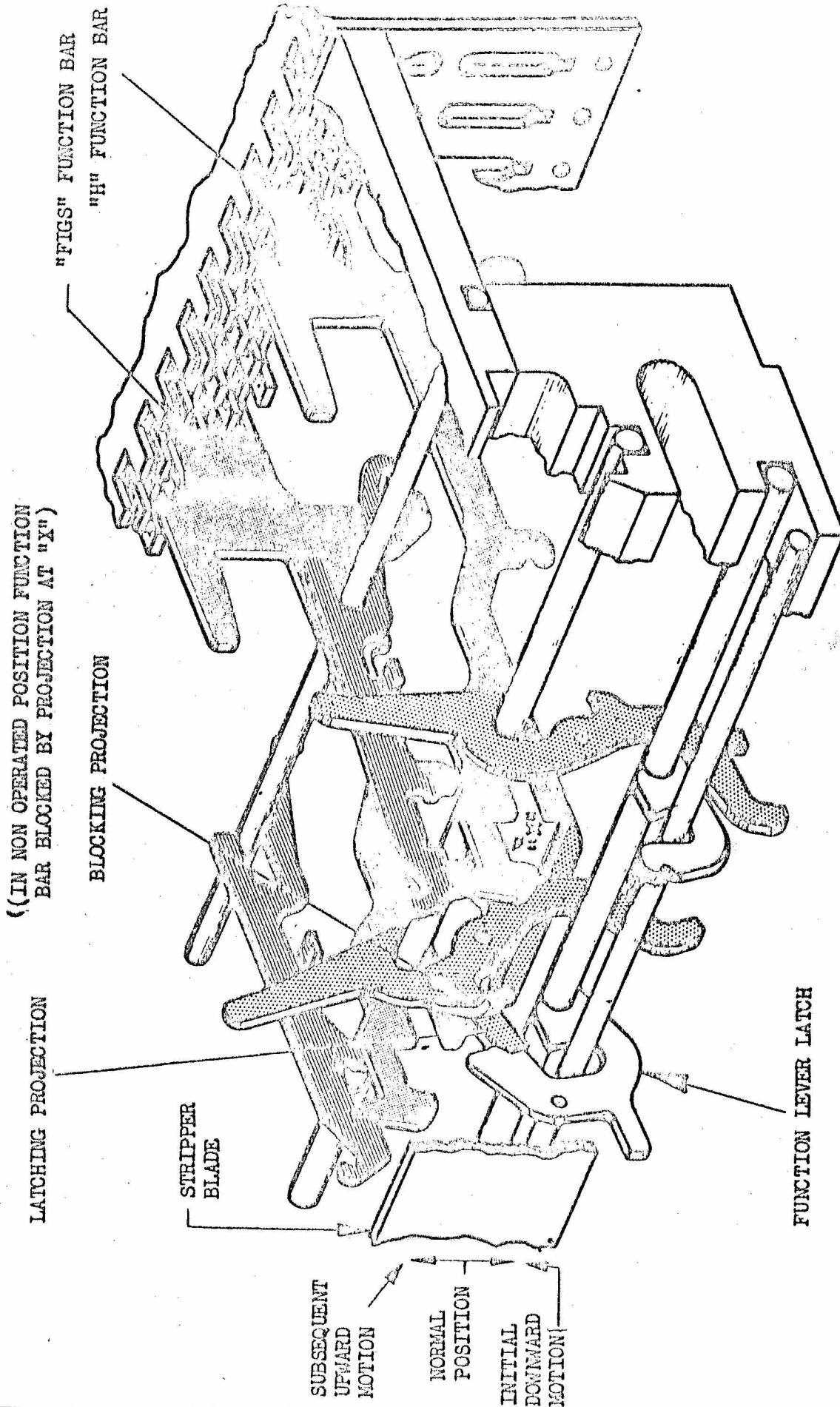

Fig. 14 - Sequential Selection of a Function

AN STUNT BOX
SELECTIVE CALLING

LBM 12/56

With the exception of a few specialized applications, the Bell System arrangement (AN) is becoming the standard for Model 28 Selective Calling. It must be remembered, however, that the AN Stunt Box arrangement is merely one of the, virtually limitless, ways in which the Stunt Box may provide Selective Calling.

In the AN arrangement there is a four step procedure bringing printers in and, later, taking them out of selection. The steps are:

- | | | |
|--------------------------------|---|--------------------|
| 1. Condition | = | FIGS - H - LTRS |
| 2. CDC (Call Directing Code) | = | U - LTRS |
| 3. End of Address | = | C.R. - L.F. - LTRS |
| 4. End of Message | = | FIGS - H + LTRS |

A LTRS combination follows the selecting combination in each of the four steps indicated above. Except in the case of the busy light (explained below), this LTRS combination serves only to introduce a time lag because there are no LTRS function bars associated with the condition, CDC, EOA or EOM sequences. If, by accident, the printer were left in figures, this LTRS combination, after step 2, would return the typebox to its normal position. In step 2, only one CDC was indicated ('U'). This character is in every Stunt Box and is used for a universal call. The three slots adjacent to this character are left open for the insertion of the desired CDC's. Normally, for 1 to 20 printers, one CDC should be sufficient; from 20 to 400: 2; and from 400 on up: 3. In any event, the characters 'M', 'O', 'T', 'V' should be avoided as CDC's.

OPERATION

1. Condition - FIGS-H-LTRS

FIGS unlatches H and allows it to operate, if selected. H strips off the zero and suppression code bars, returning them to their marking position. The printer is now in the SELECT - NON-PRINT condition.

2. CDC

The CDC shifts the suppression code bar spacing thus unblocking the typebox clutch. The printer is now in the SELECT- PRINT condition.

3. End of Address - C.R. - L.F. - LTRS

(After step # 2 it is possible to begin transmitting. However, if the character, which had been assigned as a CDC of another printer, were hit, it too would start copying because, at this stage, all printers in the circuit are in the SELECT condition. Consequently, an EOA must be transmitted to block unselected printers.)

C.R. unlatches L.F. and allows it to operate, if selected. L.F. shifts the zero code bar to a spacing position. The selected machine is now in NON-SELECT - PRINT condition while all others are in Non-Select - Non-Print.

(Because the zero code bar is in the non-select, spacing position while traffic is being received, AN printers are not equipped with automatic C.R./L.F. which operates off the zero code bar in a spacing position.)

4. End of Message - FIGS - H - LTRS

Same as condition code. If the End of Message combination had previously been transmitted, the first step, condition, serves only as insurance.

SWITCHES (Slots 25 through 28)

- Slot # 25: Standard U.C. 'S' which will operate the signal bell. (N/O)
- Slot # 26: A N/C switch that will shut-off the printer's Busy Lamp upon receipt of either the condition or EOM sequence. Inasmuch as the operator will always send a LTRS combination, this slot requires a LTRS function bar. If there were no function bar, the light would go back on when the stripper blade went down.
- Slot # 27: A N/C switch associated with a SPACE function bar and in series with slot # 26 and the Busy Lamp. Upon transmission of a SPACE (approx. every five characters), this contact causes the Busy Lamp to flash.
- Slot # 28: A N/O switch connected to the Copy Lamp. Operates when the printer goes in to the SELECT - PRINT condition.

L.B.M.
11/28/56

(All numbers preceeded by 15-)
AN (Bell) STUNT BOX ARRANGEMENT

SLOT #	FUNCTION BAR	#	LEVER	LATCH	SW.	SHIFT FORK	PURPOSE
1	Space	5129	2642	2660		yes	Unshift on Space
2	Figs.	2666	2641	"		yes	Figs. Shift
3	Ltrs.	2665	"	"		yes	Ltrs. Shift
4							
5	C.R.	2667	2641	2660		yes	C.R.
6	'U' (SEL.)	5120	2298	2089		yes	Shift Supp. Spacing = PRINT
7							
8	Opt. CDC (SEL.)		"	"		"	"
9							
10	Figs.	2666	2121	4613			Unlatch U.C. 'H'
11	U.C. 'H'	2673	4647	2660			Oper. 154669 Rod w/31=Cond.&ROM
12							
13	C.R.	2667	2121	4613			Unlatch 14
14	L.F.	2668	2298	2089		yes	Shift zero spacing=non-select
15	Blank	2669	2641	2660			Space suppression on BL/NK
16	L.F.	2668	"	"			" " " single L.F.
17							
18							
19							
20							
21							
22							
23							
24							
25	U.C. 'S' (PRINT)	3437	2641	2660			Bell
26	Ltrs.	2665	4646	4613			Busy lamp - off on ROM

AN Stunt Box - 2

SLOT #	FUNCTION	BAR	#	LEVER	LATCH	SW.	SHIFT FORK	PURPOSE
27	Space		5129	2642	2660	N/C		Busy light interrupt on SPACE
28	Univ. (PRINT-SEL)		5126	2298	2089	N/O		Copy Light after CDC
29								
30	Figs.		2666	2121	4613			Unlatch 31
31	U.C. 'H'		2673	4647	2660			See 11
32								
33								
34								
35	Blank		2669	2121	4613			Double Blank Lock w/36
36	"		"	2642	2660			"
37	L.F. (non-PRINT)		5130	"	"			Kybd. Lock in non-PRINT
38								
39								
40	L.F. (PRINT)		3435	2642	2660			L.F.
41								
42								

All use:

- 152653 - Pawl
- 4703 - Func. Bar Spring
- 154690 - Pawl
- 90517 - Lever

SUPP. ZERO

- Print - Select S M
- Non-Print - Select M M
- Print - Non-Select S S
- Non-Print - Non-Select M S



RELATED ADJUSTMENTS
MODEL 28 PRINTER

KEYBOARD UNIT

Selector lever guide adj.
None

Rocker bail detent adj.
Rocker extension adj.
Flutter lever adj.

Rocker extension adj.
Flutter lever adj.

Detent toggle stop bracket adj.
Intermediate lever stop plate adj.
Flutter lever adj.

Intermediate lever stop plate adj.
Detent toggle stop bracket adj.
Flutter lever adj.

Flutter lever adj.
None

Clutch stop lever adj.
None

Clutch shoe lever adj.
None

Code bar bail adjusting screw adj.
None

Code lever bail adj.
None

Non-repeat lever adj.
None

Keylever lock ball channel and lock ball end play adj.
Code lever bail latch lever eccentric adj.
Code lever bail non-repeat extension adj.
Code lever spring tension

Code lever bail latch lever eccentric adj.
Code lever bail non-repeat extension adj.
Keylever lock ball channel and ball end play adj.

Code lever bail non-repeat extension adj.
None

Code lever guide adj.
None

Code bar bail bumper adj.
None

Code bar latch adj.

None

Code bar bounce bracket support screw adj.

None

Generator contact adj.

None

Intermediate gear bracket

Time delay mechanism position

TYPING UNIT

Selector armature adj.

Selector magnet bracket adj.

Selector clutch stop arm adj.

Selector magnet bracket adj.

Selector clutch stop arm adj.

Selector clutch drum adj.

None

Transfer lever eccentric adj.

Intermediate arm backstop bracket adj.

Shift lever link guide adj.

Intermediate arm backstop bracket adj.

None

Shift lever drive arm adj.

Shift lever link guide adj.

Shift lever link guide adj.

None

Selector clutch stop arm adj.

None

Code bar clutch trip lever adj.

None

Function clutch trip lever adj.

None

Clutch trip shaft set collars adj.

None

Spacing clutch trip lever adj.

None

Line feed clutch trip lever eccentric post adj.

Line feed clutch trip lever adjusting screw adj.

Line feed clutch trip lever adjusting screw adj.

Line feed clutch trip lever eccentric post adj.

Type box clutch trip lever eccentric post adj.

None

Type box clutch trip lever adj.

None

Clutch shoe lever adj.

None

Clutch drum position adj.

None

Spacing gear clearance adj.

None

Spacing gear phasing adj.

Left hand margin

Right margin

Automatic carriage return arm adj.

Margin indicating lamp adj.

Line feed clutch phasing adj.

Line feed spur gear detent eccentric adj.

Rocker shaft left bracket adj.

Rocker shaft bracket eccentric stud adj.

Right vertical positioning lever eccentric stud adj.

Left vertical positioning lever eccentric stud adj.

Spacing trip lever bail cam plate adj.

Reversing slide extensions adj.

Shift slide drive linkage adj.

Vertical positioning lock lever adj.

Printing track adj.

Printing arm adj.

Ribbon feed lever stop bracket adj.

Function stripper blade arms adj.

Rocker shaft bracket eccentric stud adj.

Right vertical positioning lever eccentric stud adj.

Left vertical positioning lever eccentric stud adj.

Spacing trip lever bail cam plate adj.

Reversing slide extensions adj.

Shift slide drive linkage adj.

Vertical positioning lock lever adj.

Printing track adj.

Printing arm adj.

Ribbon feed lever stop bracket adj.

Function stripper blade arms adj.

Right vertical positioning lever eccentric stud adj.

Left vertical positioning lever eccentric stud adj.

Vertical positioning lock lever adj.

Ribbon feed lever stop bracket adj.

Function stripper blade arms adj.

Left vertical positioning lever eccentric stud adj.

Vertical positioning lock lever adj.
 Ribbon feed lever stop bracket adj.
 Function stripper blade arms adj.

Spacing trip lever bail cam plate adj.

None

Shift code bar operating mechanism adj.

None

Function reset bail blade adj.

Carriage return lever adj.

Reversing slide adjusting stud adj.

Shift slide drive linkage adj.

Reversing slide extension adj.

Shift slide drive linkage adj.

Shift slide drive linkage

Rocker shaft bracket eccentric stud adj.
 Right vertical positioning lever eccentric stud adj.
 Left vertical positioning lever eccentric stud adj.
 Spacing trip lever bail cam plate adj.
 Reversing slide extensions adj.
 Vertical positioning lock lever adj.
 Printing track adj.
 Printing arm adj.
 Ribbon feed lever stop bracket adj.
 Function stripper blade arms adj.

Vertical positioning lock lever adj.

None

Oscillating rail clamp slide position adj.

Printing carriage position adj.
 Shift linkage adj.
 Left hand margin adj.
 Right margin adj.
 Automatic carriage return arm adj.
 Margin indicating lamp adj.

Carriage wire rope adj.

Oscillating rail slide position adj.
 Printing carriage position adj.
 Left hand margin adj.
 Right margin adj.
 Automatic carriage return arm adj.
 Margin indicating lamp adj.

Type box carriage roller adj.

Printing hammer stop bracket adj.
 Printing arm adj.

Printing carriage lower roller adj.
Printing track adj.
Printing hammer stop bracket adj.
Printing arm adj.

Carriage return spring adj.
Dashpot vent screw adj.

Carriage return latch bail adj.
None

Carriage return lever adj.
None

Dashpot vent screw adj.
None

Printing carriage position adj.
Shift linkage adj.

Shift linkage adj.
None

Printing hammer bearing stud adj.
None

Printing track adj.
Printing arm adj.

Printing hammer stop bracket adj.
Printing arm adj.

Printing arm adj.
None

Printing hammer operating bail spring adj.
Printing arm adj.

Left hand margin adj.
Right margin adj.
Automatic carriage return arm adj.
Margin indicating lamp adj.

Right margin adj.
None

Ribbon reverse spur gear adj.
Ribbon reverse detent adj.

Ribbon reverse detent adj.
None

Ribbon feed lever stop bracket adj.
None

Line feed spur gear detent eccentric adj.

None

Function stripper blade arms adj.

None

Single-double line feed lever adj.

None

Automatic carriage return arm adj.

None

Paper straightener collar adj.

None

Paper finger adj.

None

Bell or motor stop function contacts adj.

None

Unshift on space function pawl adj.

None

Code bar detent adj.

None

Margin indicating lamp adj.

None

TELETYPE SCHOOL 1271

MODEL 28 PRINTER

CLUTCH SEQUENCE CHART

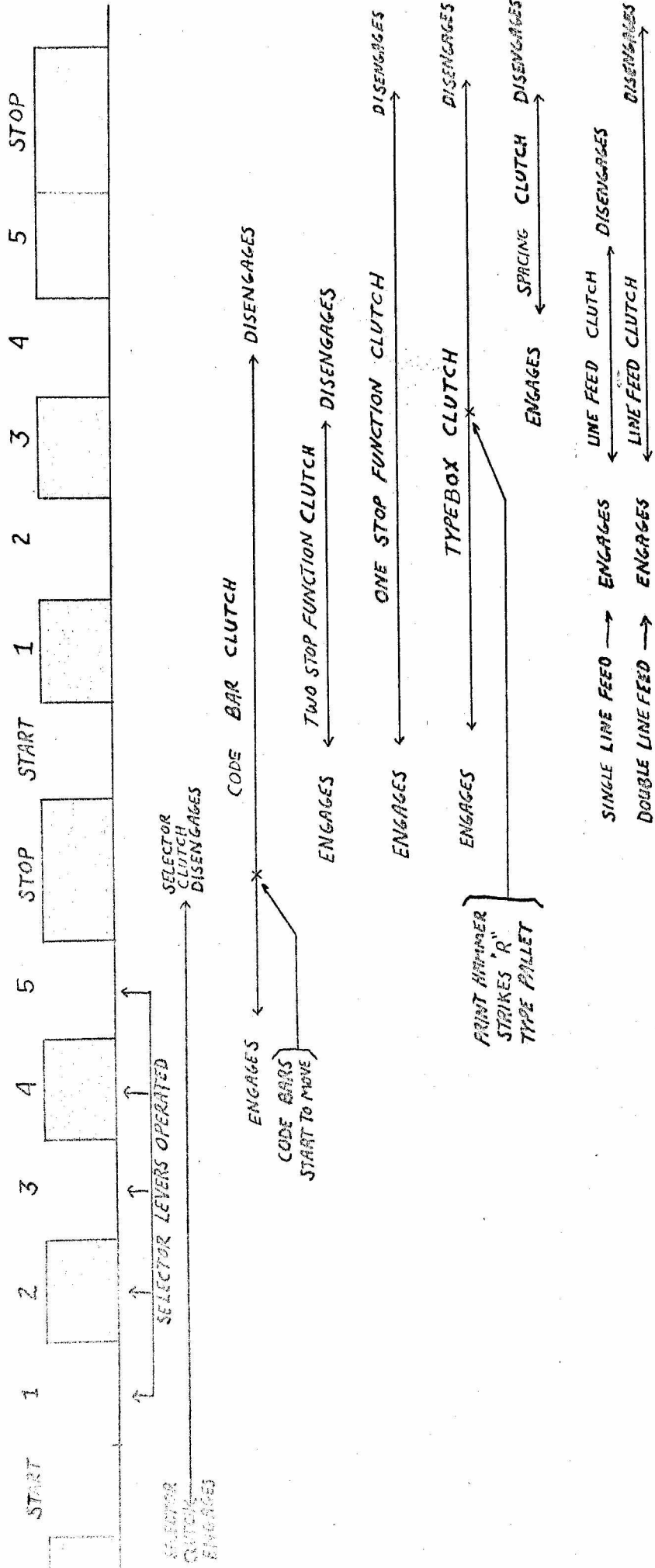

L-140

MODIFYING MODEL 28 EQUIPMENT FOR 20 MA OPERATION

(Schematic references are from NAVSHIPS Manual 99MA)

I. Modification for 20ma LINE Current

NOTE: The following procedure assumes that the electrical service unit is equipped with the RY30 (WECO 255A). Customers such as Western Union need to follow slightly different procedures depending upon the arrangement of their line relays.

GENERAL

In order to allow the line relay (RY30) to operate at 20 ma it is necessary to increase the resistance of the relay's bias winding. The Motor Control Relay's coils must be re-wired to a series connection and resistance added to this circuit.

PROCEDURE

1. To increase resistance of the RY30's bias winding:

On the line relay mounting assembly, move A-86-BR from its present position on the 8Kohm resistor to the open terminal on the same resistor.

NOTE: This resistor (Part # 81775 = R1203) is physically located beneath the RY30 base plate, in the LESU, electrical service unit. For 60 ma operation, this resistor will have two wires connected to the same terminal.

2. To modify the Motor Control Relay wiring:

On the Motor Control Terminal Block (part # 151411 = TB 1104) remove BK strap between terminals 7 & 9. (The Start Magnets are now in series). Remove the end of the strap from terminal 6 and connect to terminal 9. (This adds a 200ohm resistor R1101 Part # 151439 = Line balancing resistor).

II. To modify the equipment so that the selector magnets operate with 20 ma line current, the selector magnet wiring must be changed from parallel to series.

III. To operate with 60 ma LINE current and 20 ma local (selector magnet) current, it would be necessary to add resistance to the selector magnet circuit.

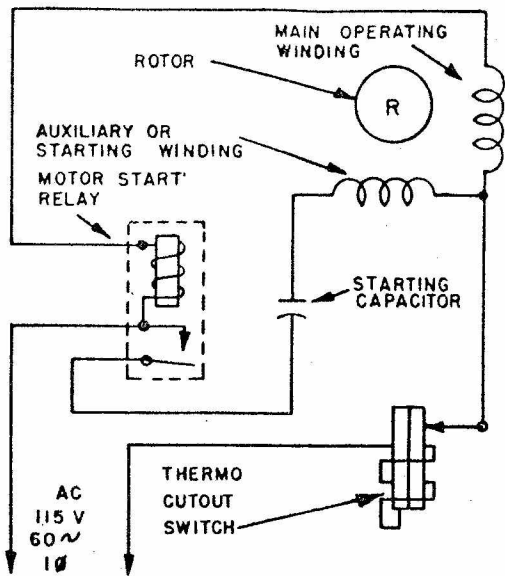

SYNCHRONOUS MOTOR UNIT,

Motor Type - A. C. Synchronous 1/20 H.P.
Speed - 3600 R. P. M.
Power Required: 115VAC, 60 Cycle ($\pm .5$ Cycle)
 Single Phase
Starting Current: Approx. 9 Amps
Thermal Cutout Level: Approx. 11 Amps

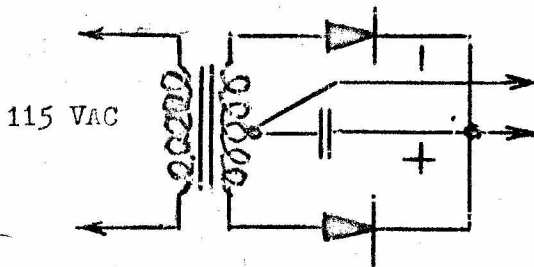

Rectifier Assembly

Input- 105-125 VAC, 60 Cycle, Single Phase
Output Voltage- 115VDC ± 5 at .012 Amp
Output Current- 150 MA Intermittant
 120 MA Continuous

A. C. Component - Not more than 2% R. M. S.

Purpose- Supplies 90MA to Line Relay
 (See Line Relay diagram)

- Composition-
1. Transformer (Primary = 260 OHMS)
(Secondary = 565 OHMS)
 2. Two $\frac{1}{2}$ wave selenium rectifiers
 3. One 220 microfarad filter capacitor

116VAC - 60 cycle - single phase

R. F. Noise suppressor
(Floor of console)

30 Console Terminal Board 29

Convenience
Receptacle
(on LESU)

Power Switch
(side of LESU to
front of console)

Rectifier
Transformer
Primary

Line Shunt
Relay

Bell

Contact
in Stunt Box

Time Delay (Kybd)

Stop Magnet of Motor
Control Relay

Motor Contact (Motor
Control Relay)

Margin Indicator
Contact on Kybd.
Lamp in upper
R/H corner of
Console.

Margin Indicator*
700 ohms

Motor
3600rpm Sync.

Normal On

Copy Light Sw.* Off

Maint. On

*Copy light Sw., once
on LESU, now located
in upper left corner
of console.

6.3VAC
Copy Lamps -
Top of Console

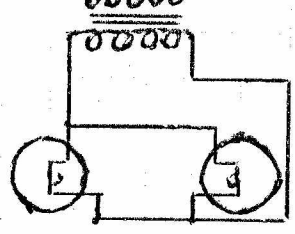

Model 28 - A.C. Power Distribution

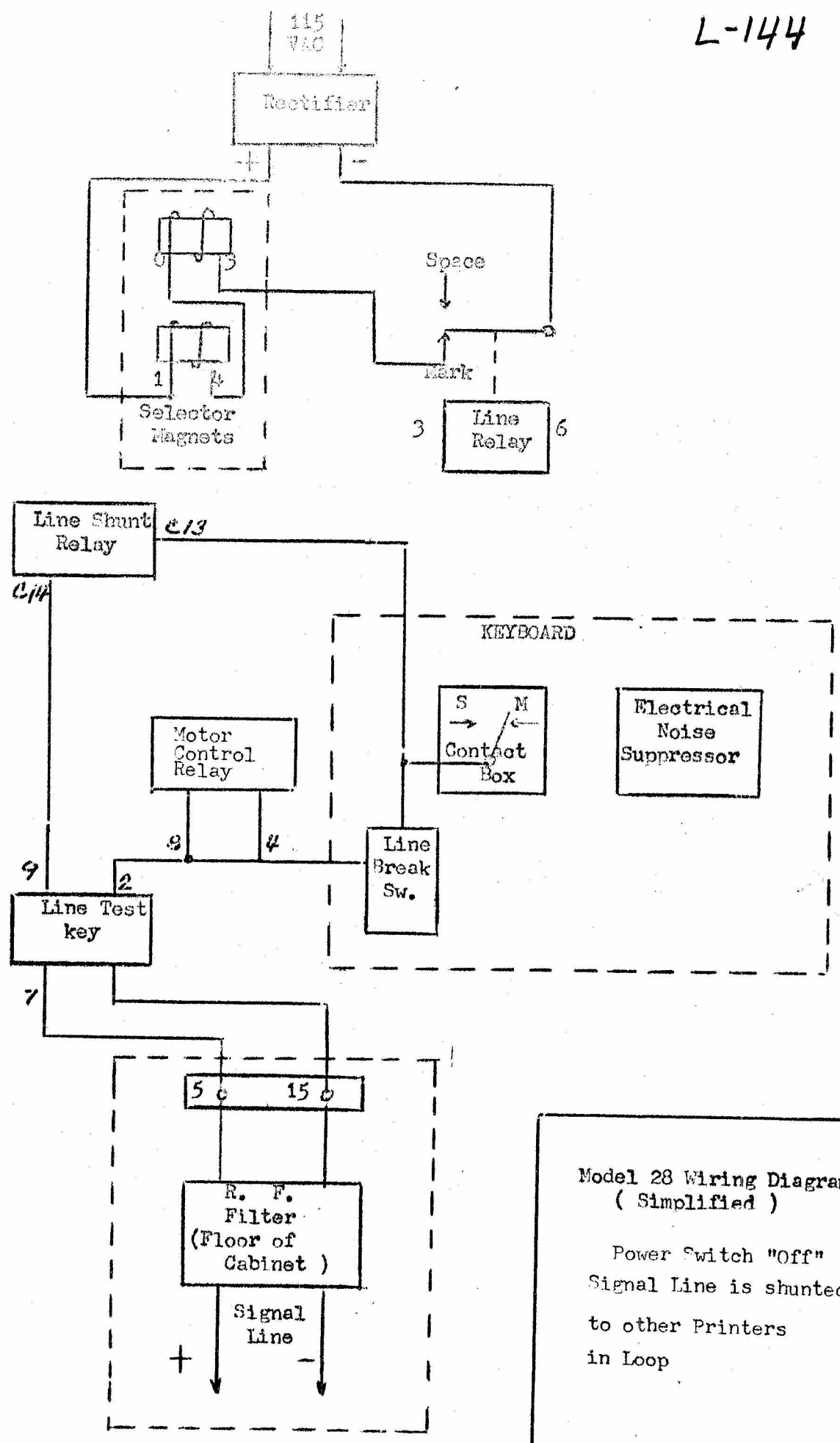

Model 28 Wiring Diagram (Simplified)

Power Switch "Off"
Signal Line is shunted
to other Printers
in Loop

LINE RELAY
(Teletype - RY-30
Western Electric - 255A)

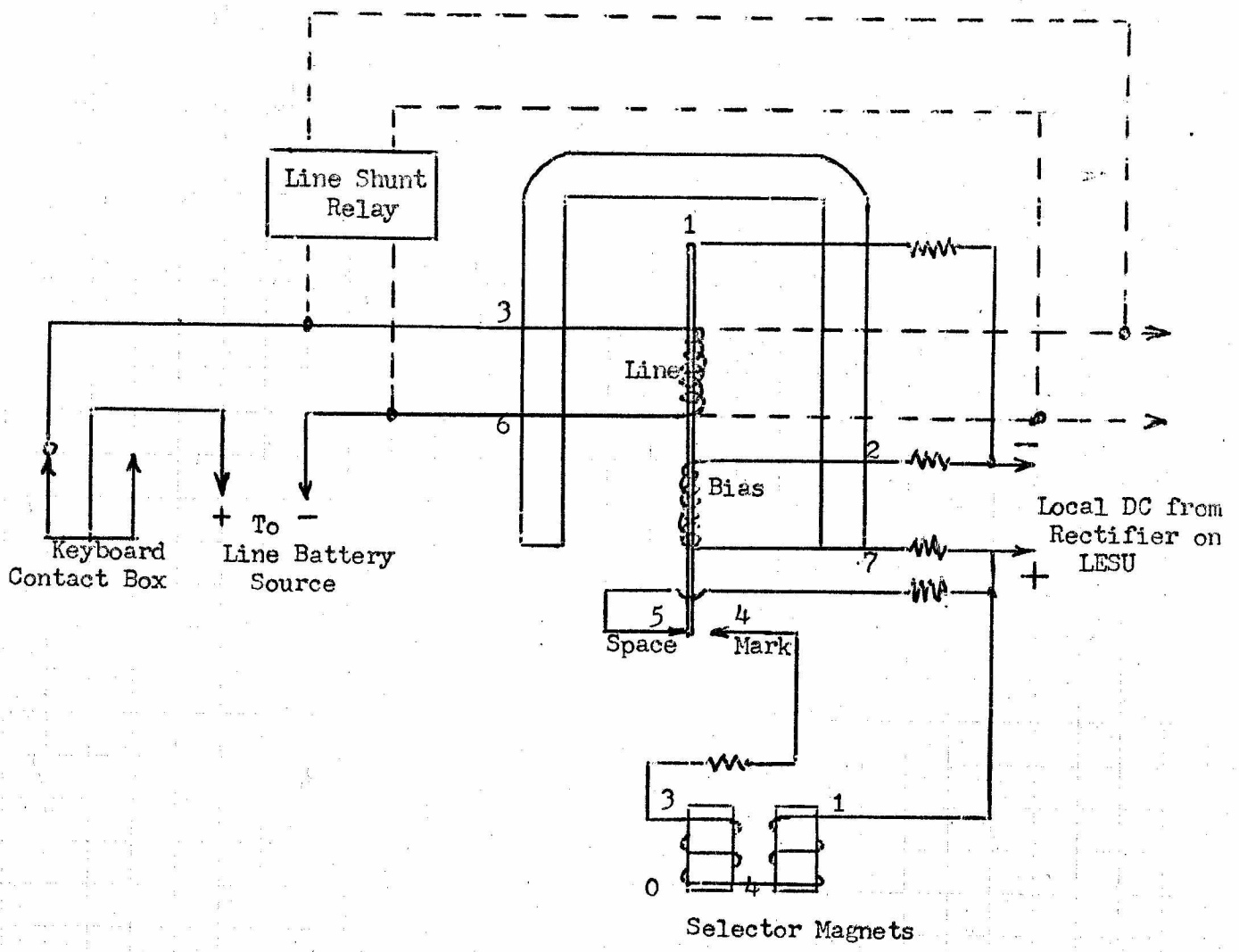

SPACE ON SIGNAL LINE:

During a spacing (no current) pulse, 30ma flows from the rectifier through the 2 - 7 winding of the relay and creates a polarity in the armature that will cause the armature to be attracted to the SPACE contact. No current may flow through the selector magnets.

At the same time, 60ma is supplied from the rectifier, through contact # 5, out at contact # 1 and back to negative battery. The purpose of this "dummy" circuit is to maintain a steady 90ma drain on the rectifier.

MARK ON SIGNAL LINE:

During a marking (current) pulse, the 60ma from the signal line, through the 3 - 6 winding, creates a polarity in the armature that will cause the armature to be attracted to the MARK contact. (The 60ma from the line overcomes the 30ma in the 2 - 7, bias, winding.) At this time, 60ma flows from the rectifier, through the selector magnets, through contact # 4, out at contact # 1 and back to negative battery.

Note: All numbers, except those on the selector magnets, indicate contacts on the bottom of the Line Relay in the LESU.

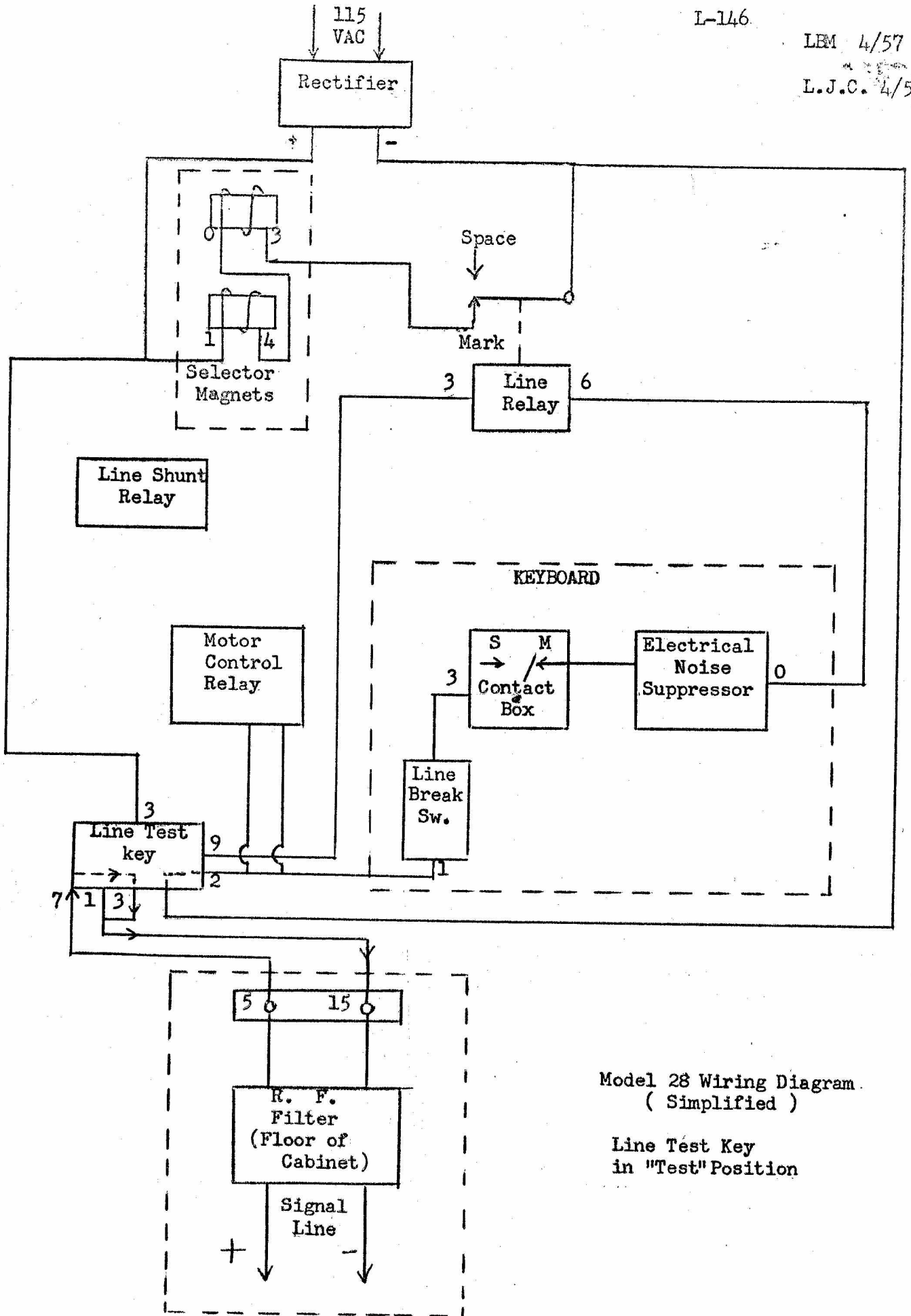

Model 28 Wiring Diagram (Simplified)

Line Test Key in "Test" Position

L-147

LEM 4/57
LJC

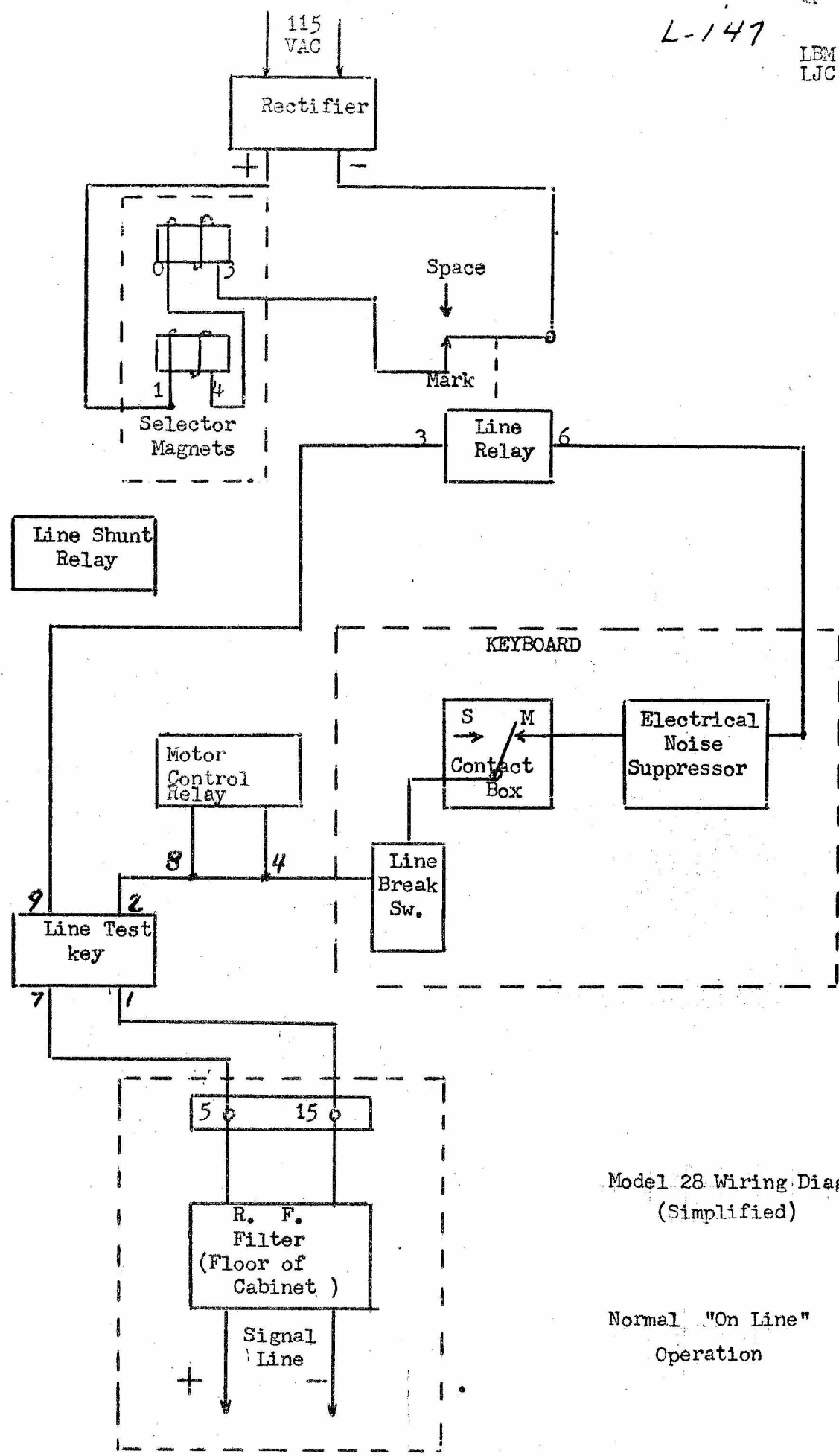

Model 28 Wiring Diagram
(Simplified)

Normal "On Line"
Operation

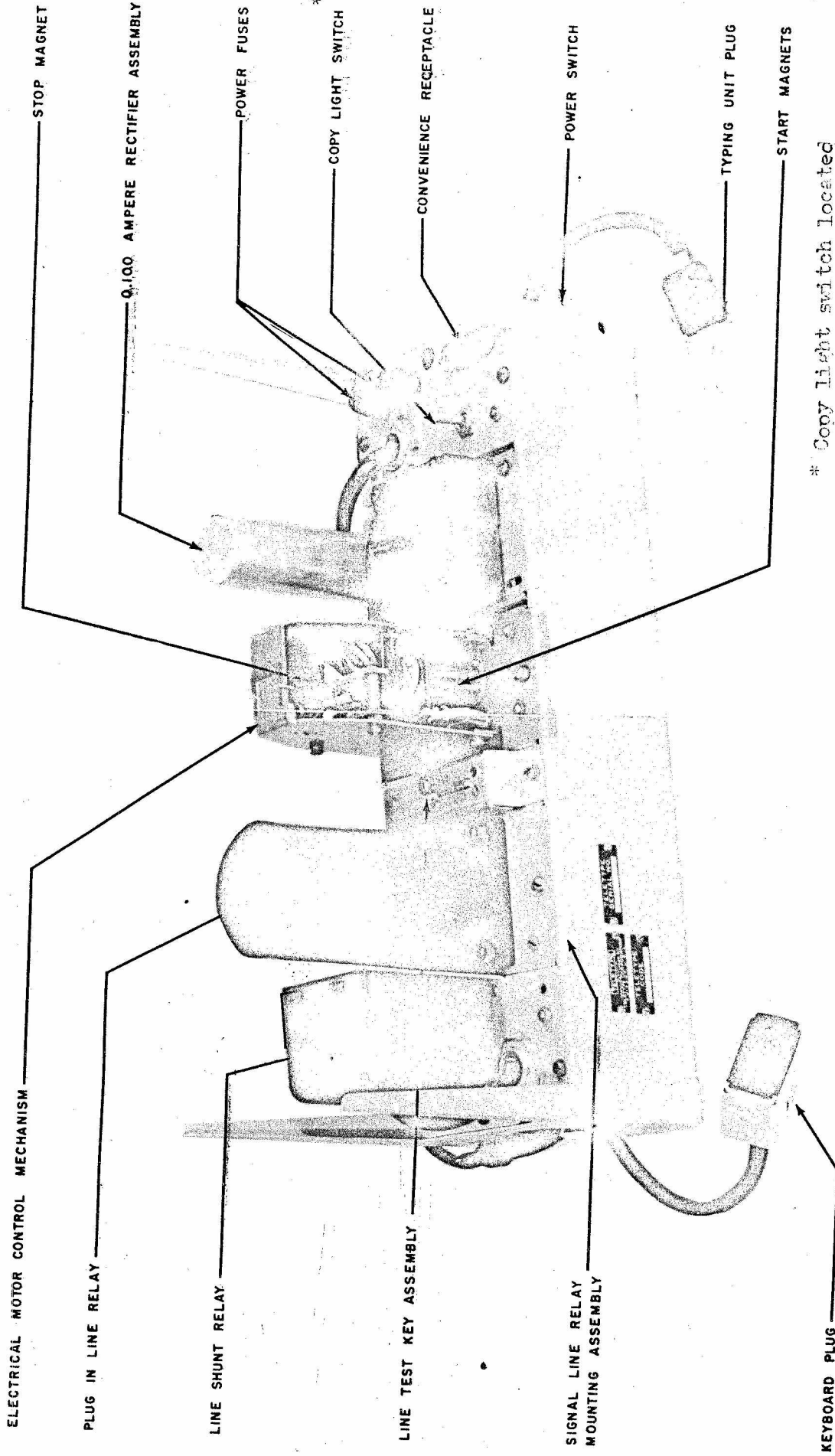

ELECTRICAL SERVICE UNIT