

BULLETIN 289B
TECHNICAL MANUAL
MODEL 32 AND 33
SELF-CONTAINED KEYBOARD

CONTENTS

PRINCIPLES OF OPERATION
ADJUSTMENTS
LUBRICATION
DISASSEMBLY AND REASSEMBLY



TELETYPE[®]
CORPORATION
5555 TOUHY AVENUE, SKOKIE, ILLINOIS



INTRODUCTION

Bulletin 289B is a technical manual that provides general and specific technical information about the 32 and 33 Self-Contained Keyboard.

The bulletin contains principles of operation, adjustments, lubrication, and disassembly and reassembly.

The bulletin is made up of a group of appropriate independent sections. The sections are complete within themselves — they are separately identified by title and section number, and the pages of each section are numbered consecutively, independent of other sections.

The identifying number of a section, a 9-digit number, appears at the top of each page of the section in the left corner of left-hand pages and the right corner of right-hand pages. The sections are placed in the manual in ascending numerical order.

To locate specific information refer to the table of contents on Page B. Find the name of the involved component in column one and the title in column two. The correct 9-digit section number will then be found in column three. Turn to Page 1 of the section indicated where the contents of that section will be found.



September, 1964
Original

TABLE OF CONTENTS

<u>Equipment</u>	<u>Title</u>	<u>Section</u>	<u>Issue</u>
32 and 33 Keyboard	Principles of Operation	574-121-100TC	1, Add 1
32 and 33 Keyboard	Adjustments	574-121-700TC	1, Add 1
32 and 33 Keyboard	Lubrication	574-121-701TC	1, Add 1
32 and 33 Keyboard	Disassembly and Reassembly	574-121-702TC	1, Add 1

Note 1: Disregard "Filing Instructions" given at the top of Page 1 of each addendum. Replaced pages have already been removed, and the replacing pages have been properly inserted. Also, Page 1 of each addendum has been placed ahead of Page 1 of the section to which it applies.

Note 2: The additions and changes specified in the text of each addendum have not been incorporated into the body of the applicable sections. Customers should note the additions and changes and take appropriate action.



REPLACING PAGE ADDENDUM

Filing Instructions:

1. Remove from the section the pages numbered the same as those attached to this addendum.
2. Insert the attached pages into the section in their place.
3. Place this addendum ahead of Page 1 of the section.

32 AND 33 KEYBOARD

PRINCIPLES OF OPERATION

1. GENERAL

1.001 This addendum supplements section 574-121-100TC, Issue 1. The attached pages must be inserted in the section in accordance with the filing instructions above.

1.002 This addendum is issued to add information not included in Issue 1 of the section.

1.003 Make the following changes or additions:

(a) Page 1, Contents, add:

3. SELF-CONTAINED KEYBOARD	9
Description	9
Technical Data	10

(b) Page 1, after 2.01, change "Note" to "Note 1" and add the following:

Note 2: On self-contained keyboards the parallel output of the set of keyboard contacts is transmitted to a 36-point connector, not to a distributor mechanism. At the 36-point connector the coded intelligence can be tapped for direct entry into electronic devices such as computers and associated business machines or other communications equipment.

Attached:

- Page 1 dated September 1964, revised
- Page 2 dated September 1964, reissued
- Page 7 dated September 1964, reissued
- Page 8 dated September 1964, revised
- Page 9 dated September 1964, added
- Page 10 dated September 1964, added

- (c) Page 1, following 2. 02, add:

Note: Self-contained keyboards — described in Part 3 — do not have a distributor mechanism.

- (d) Page 3, following 2. 11, add:

Note: There is no trip linkage or distributor clutch associated with the self-contained keyboard. Instead of being reset mechanically by a distributor clutch operating through a trip linkage, the universal lever is reset to its down position by a reset solenoid. The reset solenoid is actuated by a 115 volt ac pulse which is originated in associated external circuitry. When energized, the reset solenoid, through a pivoted linkage, moves a reset arm downward. As the reset arm, which engages the front end of the universal lever, moves downward, it moves the universal lever to its down position where it is latched by a latchlever.

- (e) Page 4, following 2. 12, add:

Note: There is no distributor clutch on self-contained keyboards. However, the trip mechanism operates in the way described in 2. 12 to prevent the universal lever from being released when a keylever is held down.

- (f) Page 4, following 2. 15, add:

Note: In addition to other contact wires, the keyboard contact mechanism on self-contained keyboards has a universal contact which closes each time a keylever is depressed. The universal contact may be used to actuate the external circuitry which provides the 115 volt ac pulse to energize the reset solenoid and cause the universal lever to be moved to its down position.

- (g) Page 4, following 2. 16 add:

Note: Self-contained keyboards do not have a distributor mechanism. See Note 2 of 2. 01 and the Note following 2. 11.

- (h) Page 4, following 2. 18, add:

Note: Self-contained keyboards use a different technique to accomplish the repeat of the transmission of a character. But, just as in 2. 18 above, the keylever of the character to be repeated must be held down simultaneously with the REPT keylever. The different technique now becomes apparent: Self-contained keyboards have an electrical switch which is operated by the REPT keylever. When the REPT keylever is depressed, the electrical switch is operated. One set of normally open contacts, whose function is determined by the customer, close and a set of normally closed contacts open. The action of the normally closed contacts cause the reset solenoid current path to be opened. At the same time the signal circuit from the keyboard contact mechanism remains closed and permits continuous parallel signal output of the character chosen. With the reset solenoid circuit opened, the reset solenoid cannot cause the universal lever to be reset and latched in the down position (2. 11). Therefore,

the universal lever, having been allowed to move to its up position when the selected character keylever was depressed, will remain in its up position until the REPT keylever is released. When the REPT keylever is released, the normally closed contacts close and the normally open contacts open. Current can now flow in the reset solenoid circuit. When a 115 volt ac pulse is received by the reset solenoid, the universal lever will be reset to its down position, and the usual character selection can be continued in the normal manner (2.01).

- (i) Page 5, following 2. 19, add:

Note: Paragraphs 2. 19 and 2. 20 are not applicable to self-contained keyboards.

- (j) Page 5, following 2. 21, add:

Note: A self-contained keyboard does not have a distributor mechanism, therefore, when studying a self-contained keyboard, disregard so much of Figure 5 which illustrates a distributor and all of 2. 22 and 2. 23. See Note 2 of 2. 01.

- (k) Page 6, following 2. 24, add:

Note: A self-contained keyboard does not have a distributor mechanism, therefore, when studying a self-contained keyboard, disregard so much of Figure 7 which illustrates a distributor and so much of 2. 25, 2. 26, and 2. 29 which is written about a distributor. See Note 2 of 2. 01.



32 AND 33 KEYBOARD
PRINCIPLES OF OPERATION

CONTENTS	PAGE
1. GENERAL	1
2. TRANSMISSION	1
GENERAL	1
KEYBOARD	1
A. Codebar Mechanism	1
B. Universal Mechanism	3
C. Keyboard Contact Mechanism.	4
D. Line Break	4
E. Repeat	4
EXAMPLE	4
A. General	4
B. 32 Keyboard	5
C. 33 Keyboard	6

1. GENERAL

1.01 This section is issued to provide principles of operation for the 32 and 33 keyboard and to present the principles as a separate section.

1.02 The teletypewriter code used to transmit messages is described in the appropriate typing unit section. This keyboard section outlines in general terms the overall operation of the keyboard and explains in detail the operation of the components that make it up.

1.03 References to "left," "right," "front," or "rear," etc, consider the keyboard to be viewed from a position where the spacebar faces up and the contact mechanism is located to the viewer's right.

1.04 In the illustrations, fixed pivots are solid black, and floating pivots—those mounted on parts that move—are cross-hatched.

2. TRANSMISSION

GENERAL

2.01 Transmission of messages is accomplished by an operator selectively depressing the keys and spacebar of the keyboard in the same manner as in typing. The downward movement of each key or the spacebar is translated by a codebar mechanism into mechanical arrangement corresponding to the code combination representing the character on the keytop. The mechanical arrangements set up the code combinations in a set of keyboard contacts, and, by parallel output, the code combinations are transmitted to a distributor mechanism. A universal mechanism trips a distributor clutch, and a distributor mechanism then translates the parallel output from the keyboard contacts into corresponding start-stop signal for application to the transmission facilities.

Note: For a further discussion of transmission principles, see the appropriate typing unit section.

KEYBOARD

2.02 In conjunction with a distributor mechanism, the keyboard provides facilities for transmitting messages by the manual operation of a group of keys. The 32 and 33 keyboards are described in the appropriate keyboard section.

A. Codebar Mechanism

2.03 The codebar mechanism is illustrated in Figure 1.

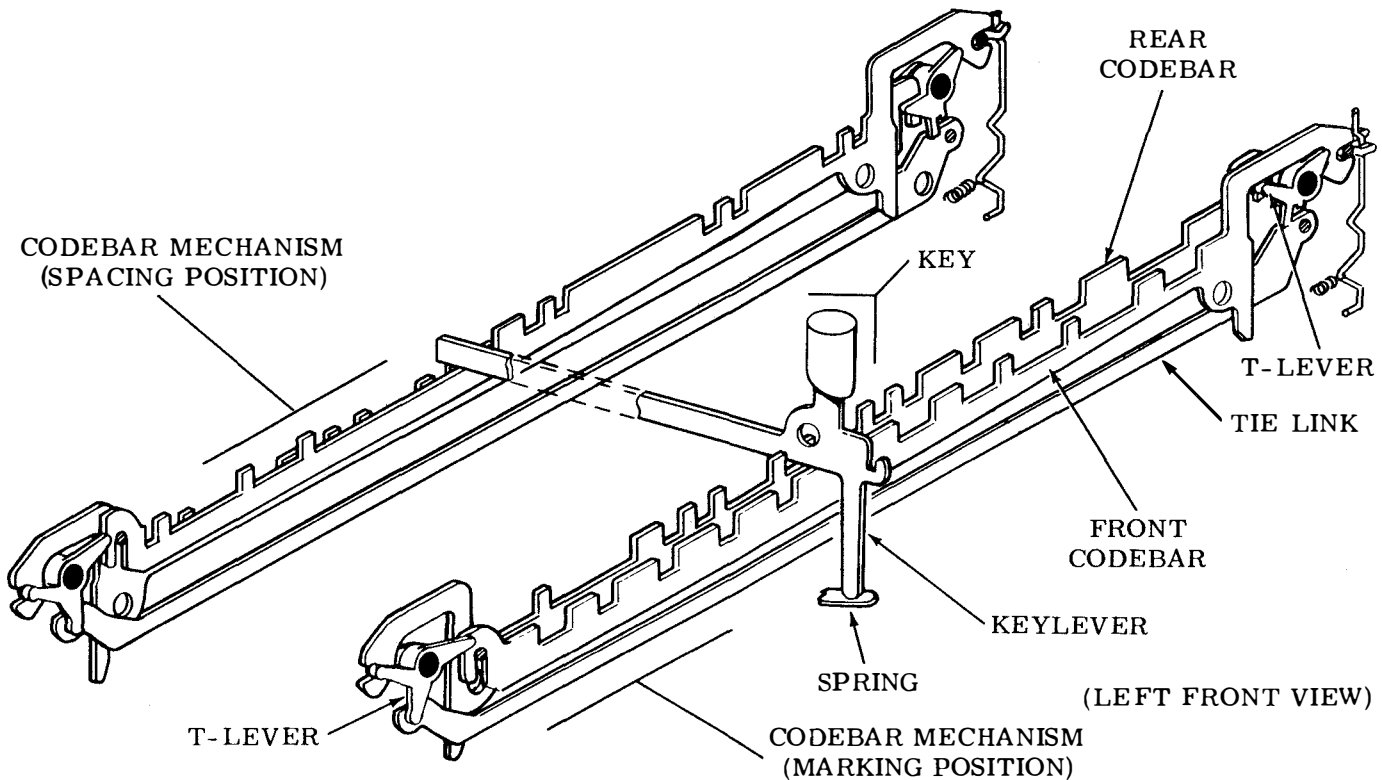

Figure 1 - Codebar Mechanism

2.04 For each intelligence element of the code, there is a codebar submechanism which consists of a front codebar, rear codebar, a tie link, and two T-levers. The mechanisms are numbered from rear to front according to the corresponding code elements—1 through 5 for the 32 keyboards and 1 through 8 for 33 keyboards. In addition, there is a universal codebar mechanism (Figure 2), consisting of one codebar, a tie link, and two T-levers.

2.05 The codebars have slots in their top edges which codes them so they are selectively depressed by the keys' keylevers. Each mechanism has a marking and a spacing position. In the marking position, the front codebar is down, the rear codebar is up, and the right T-lever is in the clockwise position. The spacing position is the opposite: front codebar up, rear codebar down, and right T-lever in counterclockwise position.

2.06 The two codebars in each mechanism are complementary coded so that, at any keylever position, where one has a slot, the

other is solid. When a key is depressed, it is returned to its up position by a leaf spring. However, the code combination representing the key's character remains in the codebar mechanisms. When a new key is depressed, only the mechanisms whose code elements differ from those of the preceding combination are operated as illustrated.

2.07 Assume that a letter has just been transmitted—"S" for a 32 keyboard or "E" for a 33 keyboard. The "S" (1-3--) or "E" (1-3---78) code combination remains in the codebar mechanisms. Now assume that another key is depressed—"D" (1--4-) for a 32 keyboard or "I" (1--4--78) for a 33 keyboard. The keylever of the key depressed encounters a slot in the rear codebar of the no. 1 codebar mechanism of the 32 keyboard or the no. 1, 7, and 8 codebar mechanisms of the 33 keyboard. Thus, the codebar mechanisms remain marking. In the case of the no. 2 and 5 codebar mechanisms for the 32 keyboard or the no. 2, 5, and 6 codebar mechanisms for the 33 keyboard, the keylever encounters a slot in the front codebar, and they remain spacing.

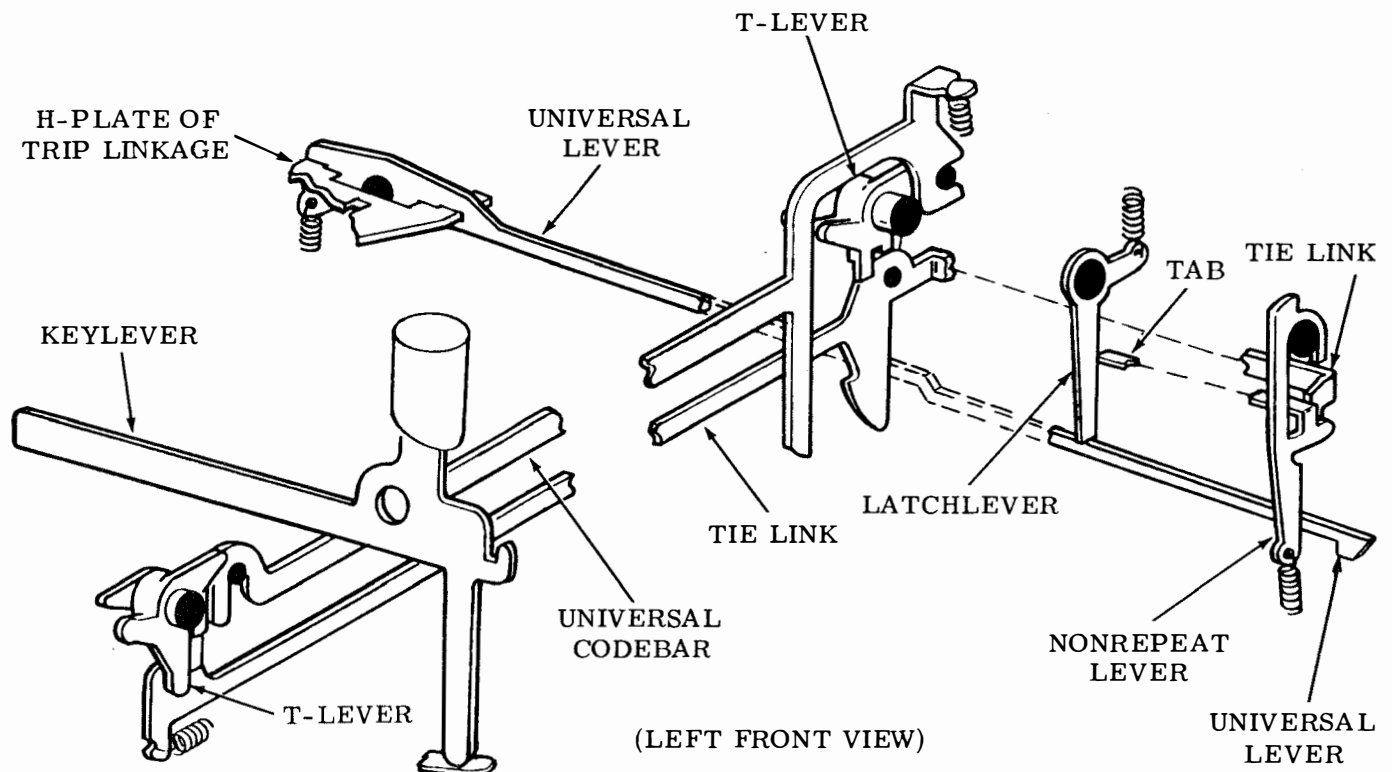

Figure 2 - Universal Codebar Mechanism

In the case of the no. 3 codebar mechanism in either the 32 or 33 keyboard, the keylever encounters the solid portion of the rear codebar and shifts it to its spacing position. In a similar manner, the keylever encounters the solid portion of the front codebar of the no. 4 codebar mechanism of either the 32 and 33 keyboard and shifts it to the marking position.

2.08 Since each code combination is different and is locked in the codebar mechanisms, the complementary coding of the codebars serves as an interlock for the keylevers. When one keylever is depressed, another cannot be depressed because it will be blocked by the solid portion of one or more codebars.

B. Universal Mechanism

2.09 The universal codebar mechanism is illustrated in Figure 2.

2.10 As a keylever nears the bottom of its travel, it depresses a codebar which is part of the universal codebar mechanism.

The codebar, in turn, causes associated T-levers to pivot and a tie link to move to the left. After some free movement, the tie link encounters a tab on a nonrepeat lever and pivots the latter to the left. The tab, in turn, pivots a latchlever which releases a universal lever. Under spring pressure, the universal lever moves up and lifts the nonrepeat lever so that its tab is moved from between the universal tie link and the latchlever. Under spring pressure, the latchlever and nonrepeat lever move back to the right to their unoperated position.

2.11 In its up position, the universal lever locks the right intelligence T-levers in the positions set up by the keylever, permits a contact bail to pivot to its down position and, through a trip linkage, trips the distributor clutch. Near the end of the distributor cycle, the trip linkage moves the universal lever back to its down position where it is latched by the latchlever.

2.12 Should the keylever remain depressed beyond the end of the distributor cycle, when the universal lever moves to its down

position, the nonrepeat lever under spring tension moves down until it hangs up on the top of the universal tie link which is still in its left position. When the keylever is finally released, the tie link moves back to the right and permits the nonrepeat lever to move all the way down so that its tab is again between the tie link and the latchlever. The trip mechanism operates in this way to prevent the distributor clutch from being retripped when a keylever is held down.

C. Keyboard Contact Mechanism

2.13 The keyboard contact mechanism is illustrated in Figure 3.

2.14 The codebar mechanisms set up the code combinations in a set of keyboard contacts. A contact wire is associated with each right T-lever excluding the universal. In the stop condition of the keyboard, a contact bail is held in its up position by the universal lever, and, in turn, holds the contact wires to the right away from the T-levers.

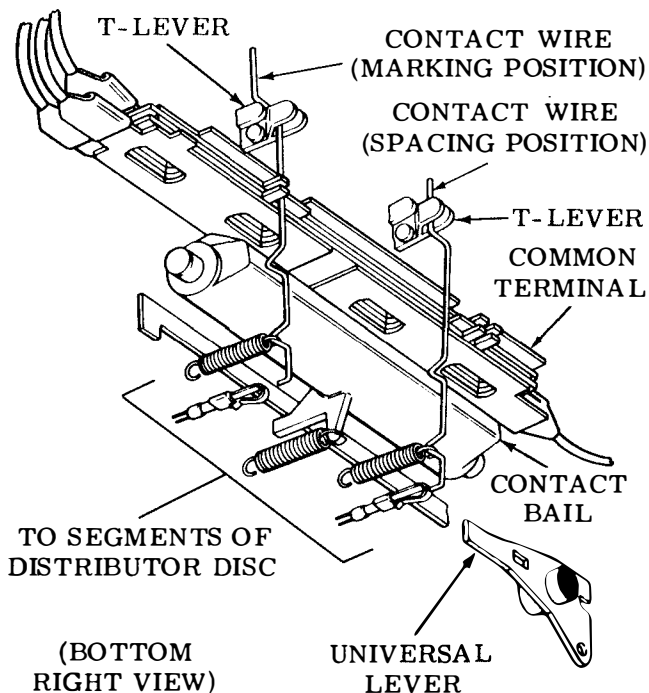

Figure 3 — Keyboard Contact Mechanism

2.15 When a keylever is depressed, a code combination is set up in the codebar mechanisms. The universal lever moves to its up position and permits the contact bail to pivot under spring pressure to its down position. The contact wires associated with the T-levers that are in the marking (clockwise) position are permitted under spring pressure to move to the left against a common terminal. Those associated with the T-levers that are in the spacing (counterclockwise) position are held to the right away from the terminal. For example, if a code combination—"D" (1--4-) for a 32 keyboard or "I" (1--4--78) for 33 keyboard—is in the codebar mechanism as described in 2.07, the no. 1 and 4 contact wires for a 32 keyboard or no. 1, 4, 7, and 8 contact wires for a 33 keyboard are against the common terminal. Similarly the no. 2, 3, and 5 contact wires for a 32 keyboard or the no. 2, 3, 5, and 6 contact wires for a 33 keyboard are away from the common terminal.

2.16 The distributor mechanism converts these positions to start-stop signals. Near the end of the distributor cycle, the universal lever moves back to its down position and pivots the bail to its up position. The bail, in turn, cams the contact wires back to the right and holds them there in the stop position.

D. Line Break

2.17 When a BREAK key is depressed, it pivots a T-lever which opens the break contact (Figure 5). This action opens the signal line until the BREAK key is released.

E. Repeat

2.18 To repeat the transmission of a character, its keylever is held down along with the REPT keylever. The latter holds the nonrepeat lever down where its tab remains between the tie link and the latchlever (Figure 2). The latchlever is held in its left position and does not latch the universal lever at the end of the cycle. The universal lever thus moves up and trips the distributor clutch causing the character to be retransmitted as long as the REPT key is depressed.

EXAMPLE

A. General

2.19 In the stop position, the distributor clutch is disengaged, and the outer brush rests on the distributor disc stop segment.

When a key is depressed, the proper code combination is set up in the keyboard contacts and the universal lever moves to its up position. The motion of the transfer lever is conveyed by an H-plate to a distributor trip linkage on the typing unit. The trip linkage pivots a trip bail which carries a trip lever rearward out of the way of the distributor clutch's shoe lever. The clutch engages and rotates the distributor shaft and brush holder. The outer brush passes over the distributor disc segments on the outer disc in the following order: (1) start, no. 1 through no. 5, and stop for 32 typing units; and (2) start, no. 1 through no. 8, and stop for 33 typing units. Near the end of the distributor shaft's revolution, a roller on the distributor clutch's disc pivots a follower lever which moves the trip bail and lever frontwards. This motion is transferred through the trip linkage and H-plate to the universal lever which is moved to its down position, where it is latched. When the distributor clutch completes its revolution, the shoe lever strikes the trip lever, and the distributor clutch disengages.

2.20 The effect of the above operation is to apply a start-stop code combination to the signal line corresponding to the combination set up in the keyboard contacts.

B. 32 Keyboard

2.21 Figure 4 illustrates a 32 Keyboard arrangement. Figure 5 is simplified schematic of the signal wiring of the 32 keyboard contacts.

2.22 In the stop position, the outer brush rests on the stop distributor disc segment, and current flows in the signal circuit which is closed (the path being from one side of the line through the start distributor disc segment, the inner distributor disc, the brushes, the stop distributor disc segment, the common terminal, and the break contact to the other side of the line). Thus a marking condition exists. Assume again that the "D" key is depressed. The (1--4-) code combination is set up in the keyboard contacts.

2.23 The distributor clutch is tripped, and the brush holder begins its revolution. While the brush is on the start distributor disc segment, the circuit is open, no current flows, and a spacing element is transmitted. While it is on the no. 1 distributor disc segment, the circuit is closed (the signal path being through the start distributor disc segment, the inner distributor disc, the brushes, the no. 1 distributor disc segment, the closed no. 1 contact, the common terminal, and the break contact); thus current flows, and a marking element is transmitted. While the brush is on the no. 2 and no. 3 distributor disc segments, since the no. 2 and no. 3 contacts are open, the circuit is broken, and no current flows and spacing elements are transmitted. In a similar manner, a no. 4 marking element and a no. 5 spacing element are transmitted. When the brush reaches the stop distributor disc segment, the distributor clutch is disengaged, and the line again becomes marking.

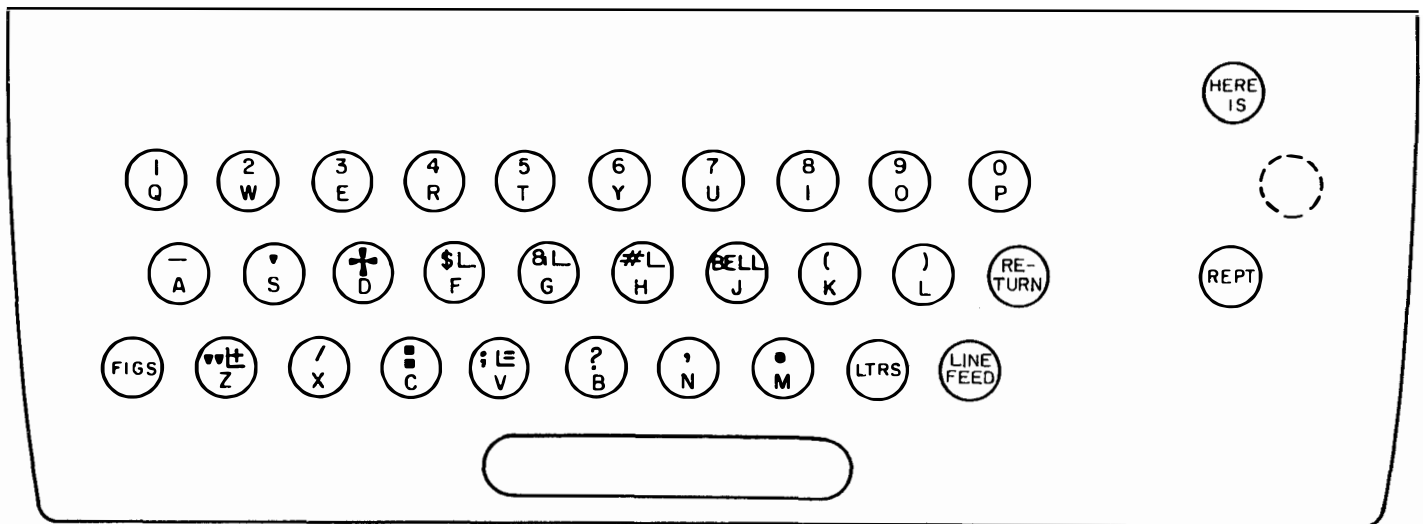

Figure 4 - 32 Keyboard Arrangement

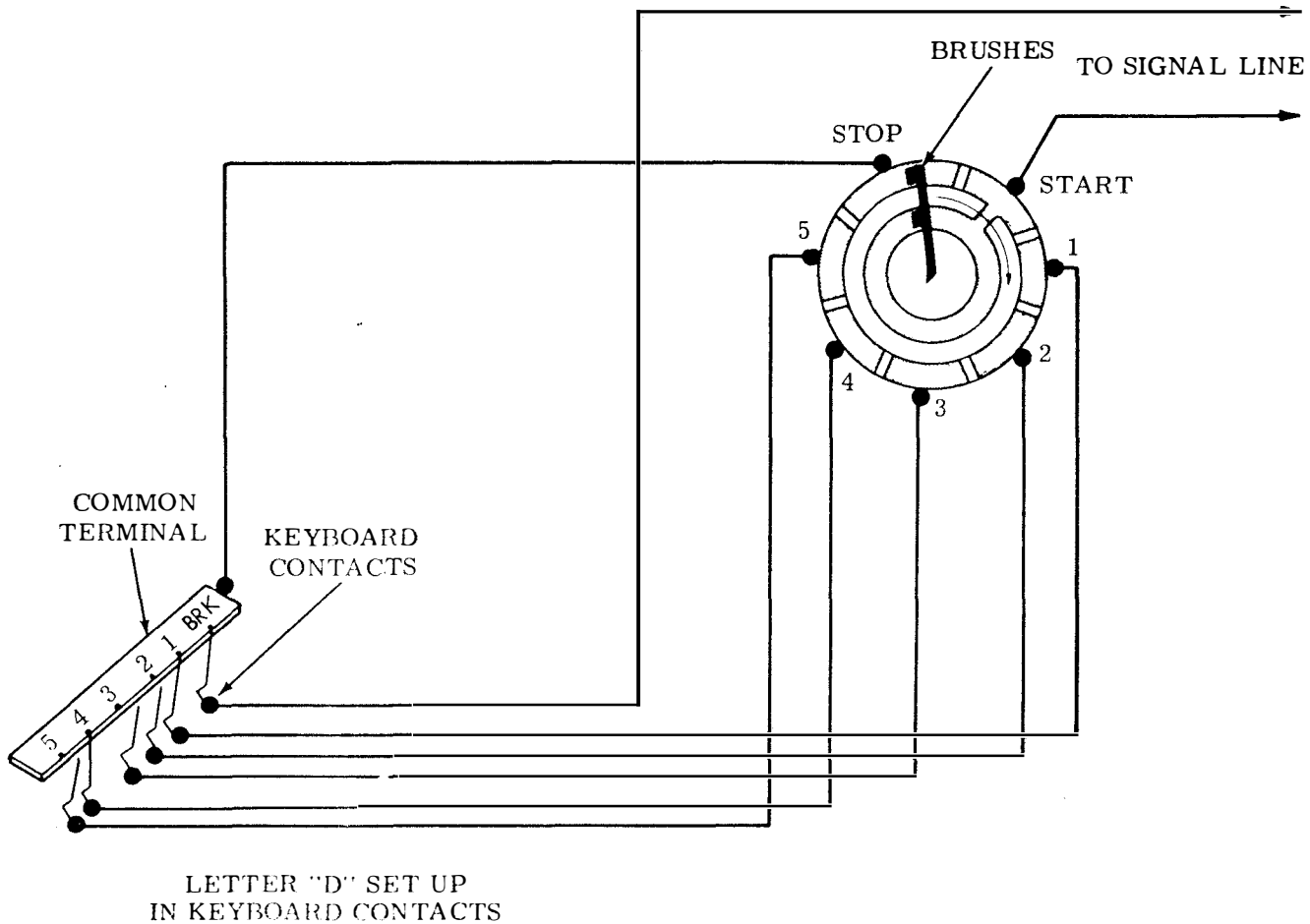

Figure 5 — Signal Wiring — 32 Keyboard Contacts

C. 33 Keyboard

2.24 Figure 6 illustrates a 33 keyboard arrangement. Figure 7 is a simplified schematic of the signal wiring for the 33 keyboard (without "even parity").

2.25 Transmission on 33 keyboards is similar to that on 32 keyboards, except that facilities are provided on the keyboard and distributor to generate the American Standard Code for Information Interchange (ASCII). The keyboard utilizes two SHIFT keys and one CTRL (control) key. The SHIFT key is used to generate the code combinations for printing characters appearing on the upper keytops (eg. "\$" that appears above "4" on the keytop in Figure 6). The CTRL key is used to generate the codes for the control characters appearing on the upper keytops (eg. "WRU"

that appears above "E" on the keytop in Figure 6). Simultaneous use of both CTRL and SHIFT keys allows access to special control functions, such as "S₅." In every case, the SHIFT and/or CTRL keys must be held down while the appropriate character key is depressed.

Note: Simultaneous depression of the CTRL and SHIFT keys accomplishes the following:

- (a) The no. 5 code element is inverted. If the code element is normally marking, it becomes spacing. If the code element is normally spacing, it becomes marking.
- (b) On 33 keyboards featuring "even parity," the no. 6 code element is converted from marking to spacing.
- (c) The no. 7 code element is converted from marking to spacing.

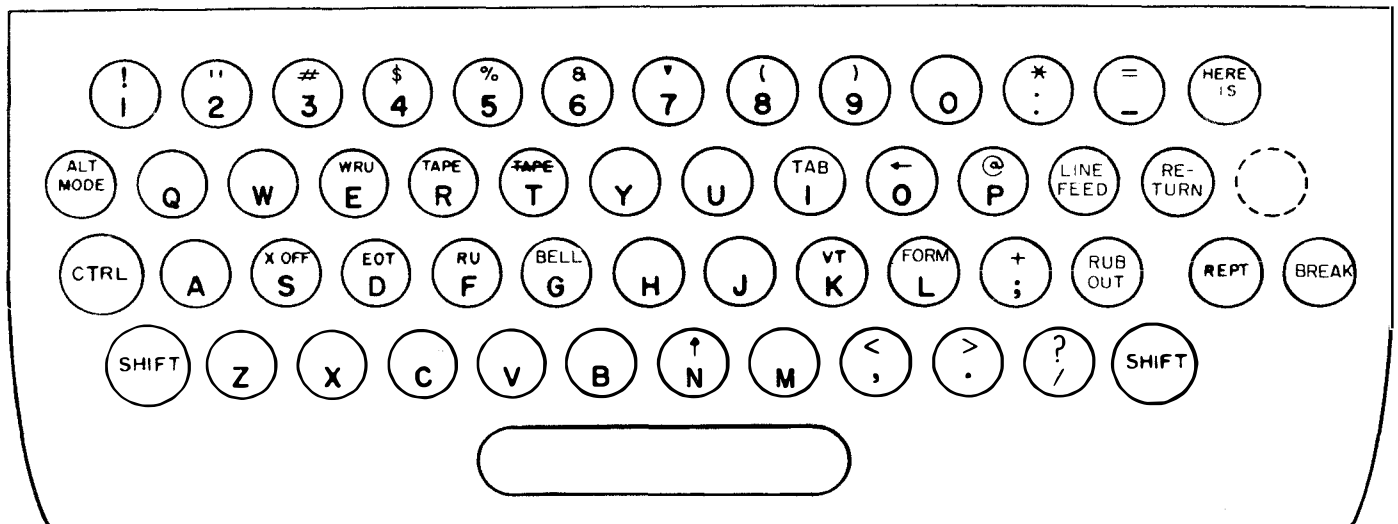

Figure 6 -- 33 Keyboard Arrangement

(d) On 33 keyboards featuring "evenparity," the no. 8 code element is inverted and reinverted, giving a "normal" no. 8 code element.

2.26 The SHIFT key inverts the no. 5 code element on all 33 keyboards. If the element is normally marking, it makes it spacing; if the element is normally spacing, it makes it marking. It does this by two 2-headed T-levers, one at the shift position, and one at the no. 5 position, each of which operates two contact wires, alternately opening one and closing the other. As shown in Figure 7, in the spacing condition, the "c" contact associated with the no. 5 T-lever is open, and the "d" contact is closed. In its unoperated position, the "a" contact associated with the SHIFT T-lever is closed, and the "b" contact is open. For example, if the "4" key alone is pressed, the code combination for "4" (--3-56-8) is set up in the keyboard contacts and subsequently transmitted. In this case, the 2-headed no. 5 T-lever holds the "c" contact closed and the "d" contact open, resulting in a marking no. 5 code element. (The signal path is through the stop distributor disc segment, the common terminal, the closed "c" contact, the closed "a" contact, the no. 5 distributor disc segment, the brushes, the inner distributor disc, and the start distributor disc segment, as shown in Figure 7.)

2.27 If the "4" key is depressed with the SHIFT key, the same condition is set up in the keyboard contacts, except that the 2-headed shift T-lever holds the "a" contact open and the "b" contact closed and thus opens the signal circuit. This results in the no. 5 code element being spacing rather than marking, and the code combination for "\$" (--3--6-8) being transmitted.

2.28 If the "N" key alone is depressed, the code combination for "N" (-234--78) is set by the codebars and subsequently transmitted to the line. In this case, the 2-headed no. 5 T-lever holds the "c" contact open and the "d" contact closed. On the other hand, if the "N" key is depressed with the SHIFT key, the same condition is set up in the keyboard contacts as before, except that the SHIFT key opens the "a" contact and closes the "b" contact and thus closes the signal circuit. This results in the no. 5 code element being marking rather than spacing and the code combination for (-2345-78) being transmitted.

Note: On keyboards featuring "evenparity," the no. 8 code element is also inverted in a manner similar to that described above for the no. 5 code element.

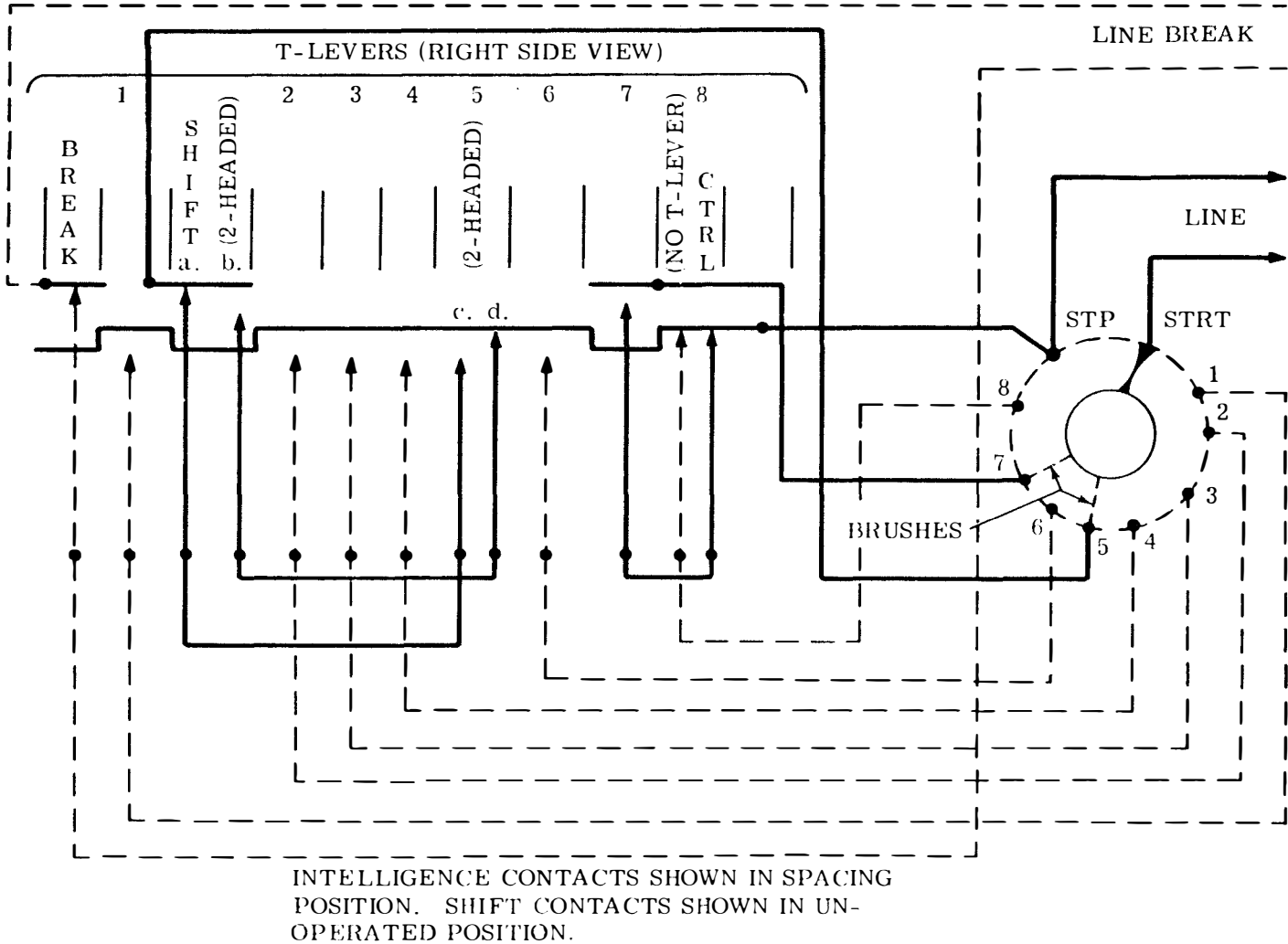

Figure 7 -- Signal Wiring - 33 Keyboard (Without "Even Parity")

2.29 The CTRL key converts the no. 7 code element from marking to spacing on all 33 keyboards. For example, if the "E" key alone is depressed, the "E" code combination (1-3---78) is set up in the keyboard contacts and subsequently transmitted. (The path of the current for the marking no. 7 code element is through the stop distributor disc segment, the common terminal, the closed control contact, the closed no. 7 contact, the no. 7 distributor disc segment, the brushes, the inner distributor disc, and the start distributor disc segment.) If the "E" key is held down with the CTRL key, the same condition as before is set up in the contacts, except that

the control T-lever opens the control contact and thus breaks the signal circuit. This results in the no. 7 code element being spacing and the code combination for "WRU" (1-3---8) being transmitted.

Note: On keyboards featuring "even parity," the CTRL key inverts no. 8 code element and converts no. 6 code element from marking to spacing, in addition to converting no. 7 code element from marking to spacing. If no. 8 code element is normally marking, the CTRL key makes it spacing. If no. 8 code element is normally spacing, the CTRL key makes it marking.

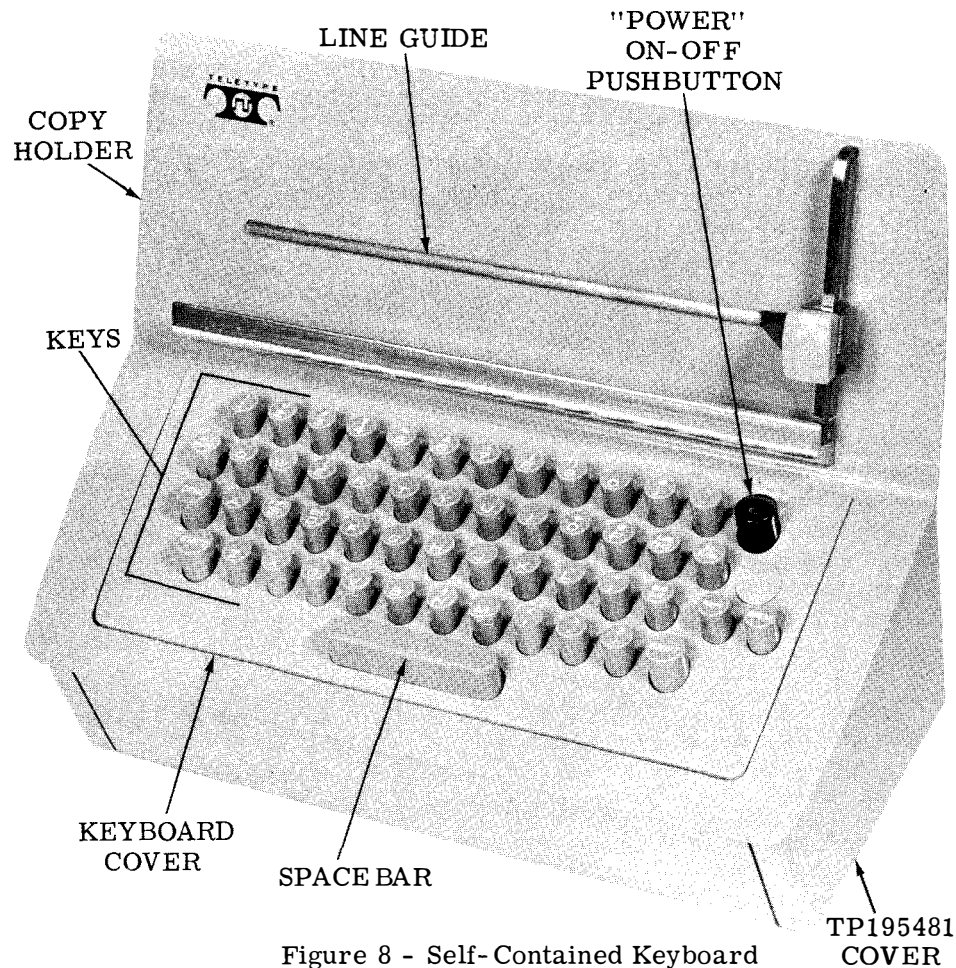

Figure 8 - Self-Contained Keyboard

3. SELF-CONTAINED KEYBOARD

DESCRIPTION

3.01 A self-contained keyboard is illustrated in Figure 8.

3.02 The self-contained keyboard is an individual piece of communications equipment which is capable of transmitting intelligence, when used in conjunction with other supplementary equipment, by the manual operation of a group of keys. It has a parallel signal output and is designed for use in applications which require a means for direct entry into electronic devices such as computers and associated business machines or other communications equipment. The self-contained keyboard includes the following components:

- (a) A spacebar and keys similar to those on a typewriter.
- (b) A codebar mechanism which converts the manual depression of the keys to mechanical positions corresponding to the proper code combinations.

- (c) A contact mechanism in which the codebar mechanism sets up the code combination.
- (d) A frame and two side brackets which support the mechanisms and a keyboard cover which serves as a guide for the keys.
- (e) A reset solenoid which, through a pivoted linkage and a reset arm, resets the universal lever.
- (f) A POWER on-off pushbutton switch which closes and opens the power input circuit, and a 6-volt lamp which lights up the POWER pushbutton when it is in the POWER-on position.
- (g) A TP195481 cover with a copyholder and line guide to provide a protective-decorative enclosure for the keyboard while adding an operating convenience to it.
- (h) A fuse which is accessible from the bottom of the keyboard and a 36-point connector are also provided.

3.03 The self-contained keyboard closely resembles a typewriter keyboard. It has four rows of keys and generates an 8-level ASCII signalling code.

(a) The characters on the lower part of the keytops, including the numerals in the upper row, can be transmitted without the use of a shift operation. A SHIFT key is used to transmit the printing characters (such as &, %, and #) appearing on the upper part of the keytops.

Note: When the SHIFT key is held down, all the keys which do not print characters appearing on the upper part of the keytops are mechanically locked and cannot be operated. This prevents transmission of false characters for those keys blocked.

(b) A control (CTRL) key is used to transmit the control functions (such as XOFF or EOT) which appear on the upper part of the keytops.

(c) Simultaneous use of both the CTRL and SHIFT keys allows access to special functions which may be provided by the keyboard. In every case, the SHIFT and/or CTRL keys must be held down while the appropriate character is depressed.

(d) Because of the frequency of use in certain applications, separate keys for certain functions, such as RE-TURN (carriage return) and LINE FEED are provided, and the CTRL key is not necessary to generate their code combinations. In the case of RE-TURN and LINE FEED, the CTRL key can be used in conjunction with either the RE-TURN or LINE FEED keys, but it is not necessary.

Note: In addition to the separate key provided, the "line feed" code combination can be generated by the simultaneous use of CTRL and J keys. Likewise, the "carriage return" code combination can be generated by the simultaneous use of the CTRL and M keys.

3.04 Technical Data:

(a) Dimensions and Weight (Approximate):

- Width 16-1/4 inches
- Depth 6-1/2 inches
- Height 10-1/8 inches
- Weight 13 pounds

(b) Electrical:

Note 1: Refer to 7012WD and 7013WD for information on making input connections.

Reset Solenoid:

Input	115 volts ac 60 cps
Resistance	220 ohms
Reset pulse length	12 to 16 milliseconds

Code Reading Contacts:

Signal line current	max 0.070 ampere
---------------------	---------------------

Note 2: Allow 7 milliseconds between the first closure of the universal contact and the reading of the code reading contacts.

REPLACING PAGE ADDENDUM

Filing Instructions:

1. Remove from the section pages numbered the same as those attached to this addendum.
2. Insert the attached pages into the section in their place.
3. Place this addendum ahead of Page 1 of the section.

32 AND 33 KEYBOARD

ADJUSTMENTS

1. GENERAL

1.001 This addendum supplements section 574-121-700TC, Issue 1. The attached pages must be inserted in the section in accordance with the filing instructions above.

1.002 This addendum is issued to add information not included in Issue 1 of the section.

1.003 Add the following notes as indicated:

(a) Add to the table of contents:

3. VARIATIONS TO BASIC UNITS

Reset arm.	14
Reset solenoid position	14
Universal contact.	15

(b) Page 1, following Paragraph 1.07, add:

Note: For self-contained keyboards, disregard the instructions concerning the removal of the keyboard from the subbase.

Attached:

- Page 5 dated September 1964, revised
- Page 6 dated September 1964, revised
- Page 7 dated September 1964, revised
- Page 8 dated September 1964, revised
- Page 9 dated September 1964, reissued
- Page 10 dated September 1964, revised
- Page 11 dated September 1964, revised
- Page 12 dated September 1964, reissued
- Page 13 dated September 1964, revised
- Page 14 dated September 1964, added
- Page 15 dated September 1964, added

- (c) Page 2, following Paragraph 1.08, add:

Note: The Distributor Trip Linkage adjustment does not apply to self-contained keyboards. Therefore, disregard any reference to it and the Trip Lever Engagement adjustment.

- (d) Page 2, following Paragraph 1.09, Note 2, add:

Note 3: For self-contained keyboards, omit information found in 1.10, 1.11, 1.12, and 1.13 and observe the following instructions: All adjustment procedures for self-contained keyboards shall be started with the universal lever latched in its down position. To latch the universal lever in its down position, fully depress the reset solenoid plunger. The keyboard is tripped when the universal lever in its up position. To trip the universal lever, depress the universal codebar or any keytop which will depress the universal codebar.

32 AND 33 KEYBOARD

ADJUSTMENTS

CONTENTS	PAGE
1. GENERAL	1
2. BASIC UNITS	5
BREAK keylever spring	12
Contact block spring	8
Contact wires	7
Contact wire spring	8
CTRL keylever spring	12
Distributor trip linkage	6
HERE IS keylever spring	12
Keylever spring	11
Latchlever spring	8
Nonrepeat lever spring	8
REPT keylever spring	12
Reset bail spring	9
Shift codebar spring	13
Spacebar spring	11
Universal lever spring	10
Universal link	5
Universal link spring	9

Required tools, not supplied with 32 or 33 Teletypewriter Sets, are listed in the appropriate maintenance tools publication.

1.03 The sequence in which the adjustments appear is that which should be followed when a complete readjustment of the keyboard is undertaken. No single adjustment should be undertaken without first completely understanding the procedure and knowing the requirements. Therefore, read a procedure all the way through before making an adjustment or checking a spring tension.

1.04 References to "left," "right," "front," "rear," etc consider the keyboard to be viewed from a position where the spacebar (Figure 3) faces up and the contact mechanism is located to the viewer's right.

1.05 Unless specifically stated otherwise, make screws or nuts friction tight to make an adjustment and tighten them securely once the adjustment has been made.

1.06 When a procedure calls for using pry points or slots to make an adjustment, place a screwdriver between the points or in the slots and pry parts in the proper direction.

1.07 When the keyboard is removed from the subbase to facilitate the making of an adjustment and subsequently replaced, recheck any adjustments that may have been affected. Also, if parts are removed from the keyboard to facilitate the making of an adjustment, be sure that they are subsequently replaced. Recheck any adjustment that may have been affected by the removal of parts.

1.08 Related adjustments are listed with some of the adjustment texts and are primarily intended to aid in trouble shooting the equipment. As an example, suppose that in searching for a trouble it is discovered that Part (2) of CONTACT

1. GENERAL

1.01 This section is issued to provide adjustment and maintenance information for the 32 and 33 keyboard and to present the information as a separate section. All information included in this section applies equally well to 5- and 8-level keyboards except where noted.

1.02 In the adjustments covered in this section, location of clearances, position of parts, and point and angle of scale applications are illustrated by line drawings. Requirements and procedures are set forth in the several texts that accompany the line drawings.

Note: The configuration of an illustration or line drawing does not necessarily indicate that it and its associated text are exclusively applicable to a particular keyboard.

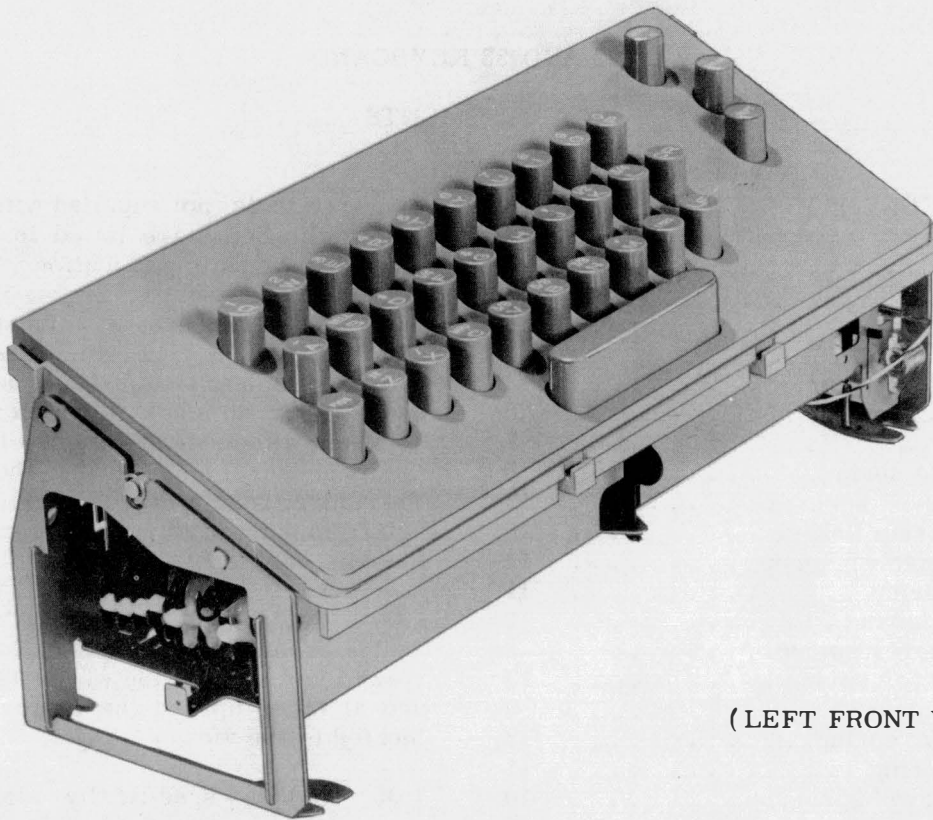

(LEFT FRONT VIEW)

Figure 1 — 32 Keyboard

WIRES adjustment does not meet its requirement. Under "Related Adjustment," it is indicated that Part (2) of this adjustment is affected by Part (1). Check Part (1) to see if it is the basic cause of the trouble. Also, note that certain adjustments affect other adjustments. For example, see the DISTRIBUTOR TRIP LINK-AGE adjustment. Note that this adjustment affects the TRIP LEVER ENGAGEMENT adjustment. (See the appropriate typing unit section.) If the former adjustment is changed, check the latter adjustment.

1.09 The spring tensions specified in this section are indications, not exact values. Therefore, to obtain reliable readings, it is important that spring tensions be measured by spring scales placed in the positions shown on pertinent line drawings. Springs that do not meet their requirements shall be replaced by new ones. Only those springs that directly affect the operation of the keyboard are measured, however, others may be measured indirectly

in the process. If, at first, the spring tension requirement cannot be met, replace the indicated spring being directly measured. Then, if the requirement is not met, any springs that are indirectly measured in the procedure shall be replaced, one at a time, with the performance of requirement checks each time a spring is replaced.

Note 1: Use spring scales which are recommended by the manufacturer of 32 and 33 Teletypewriter Sets and found in the appropriate maintenance tools publication.

Note 2: The spring tensions may be checked in any sequence.

1.10 With the keyboard and typing unit assembled together on the subbase, all adjustment procedures shall be started with the typing unit in the stop condition. It is in the stop condition when the selector armature is in its attracted

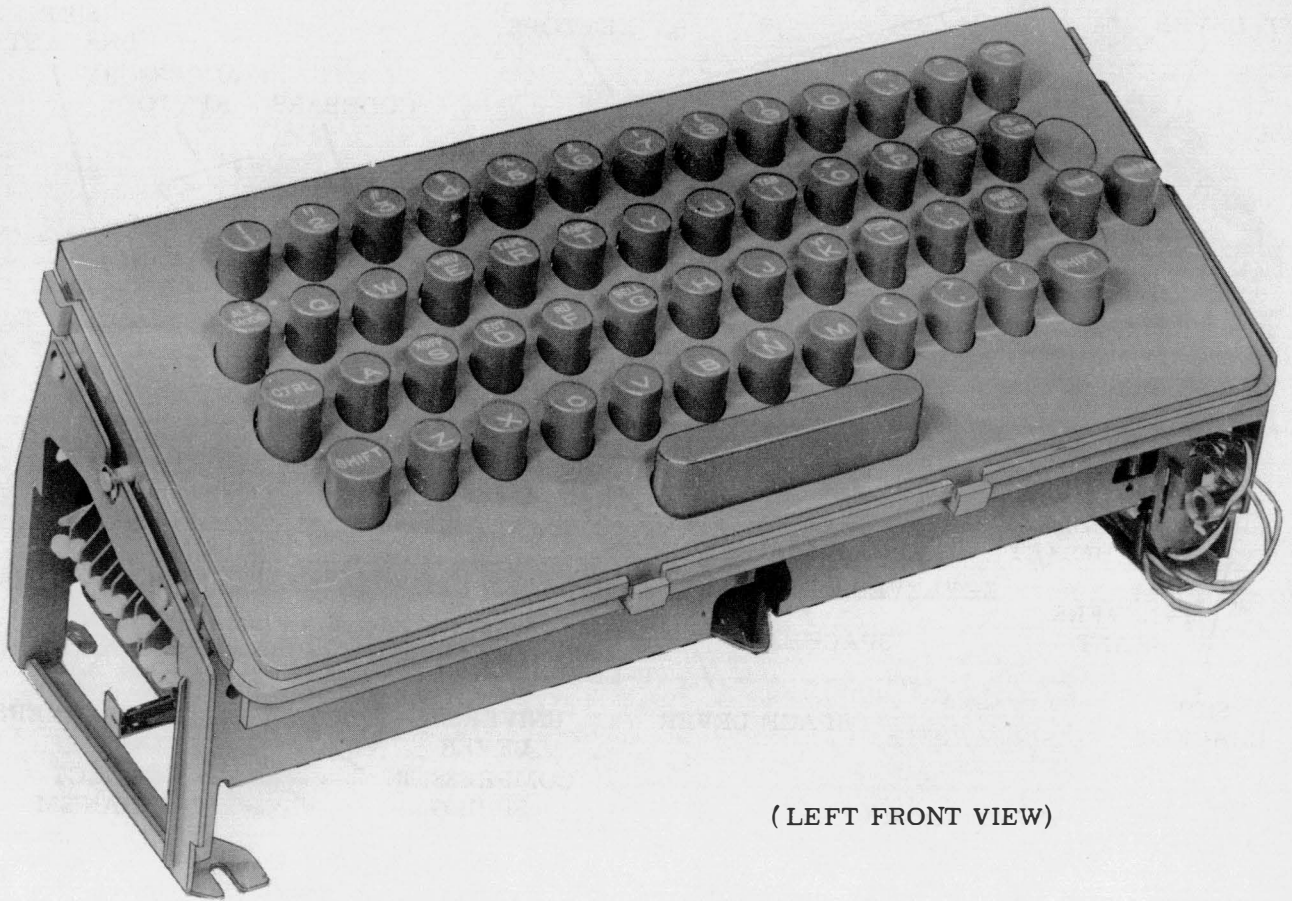

(LEFT FRONT VIEW)

Figure 2 — 33 Keyboard

(frontward) position and all clutches are disengaged. Furthermore, the keyboard universal lever shall be latched in its down position when the typing unit is in the stop condition.

Note: The keyboard is tripped when the universal lever is in its up position.

1.11 To place the typing unit in the stop condition, hold the selector armature in its attracted (frontward) position. Rotate the main shaft clockwise (as viewed from the left) until all clutches are in a stop position. Fully disengage all of the clutches as instructed in 1.12 following.

Note 1: A stop position is that position where a shoe lever contacts a trip lever.

Note 2: The distributor clutch will not disengage unless the answer-back drum is in its

home position, which is the position where the control lever is fully detented into the indent on the answer-back drum.

1.12 When disengaged, a clutch is latched so that a shoe lever is held in its stop position by a trip lever while a corresponding latchlever is seated in a notch of the clutch disc. This allows the clutch shoes to release their tensions on the clutch drum. With all clutches disengaged, the main shaft will turn freely without any clutch shoes dragging.

Note: If the shaft is turned by hand, a clutch will not fully disengage upon reaching a stop position. Where an adjustment procedure calls for disengagement, rotate the clutch to a stop position, apply a screwdriver to the associated stop-lug, and push the clutch disc in the normal direction of main shaft

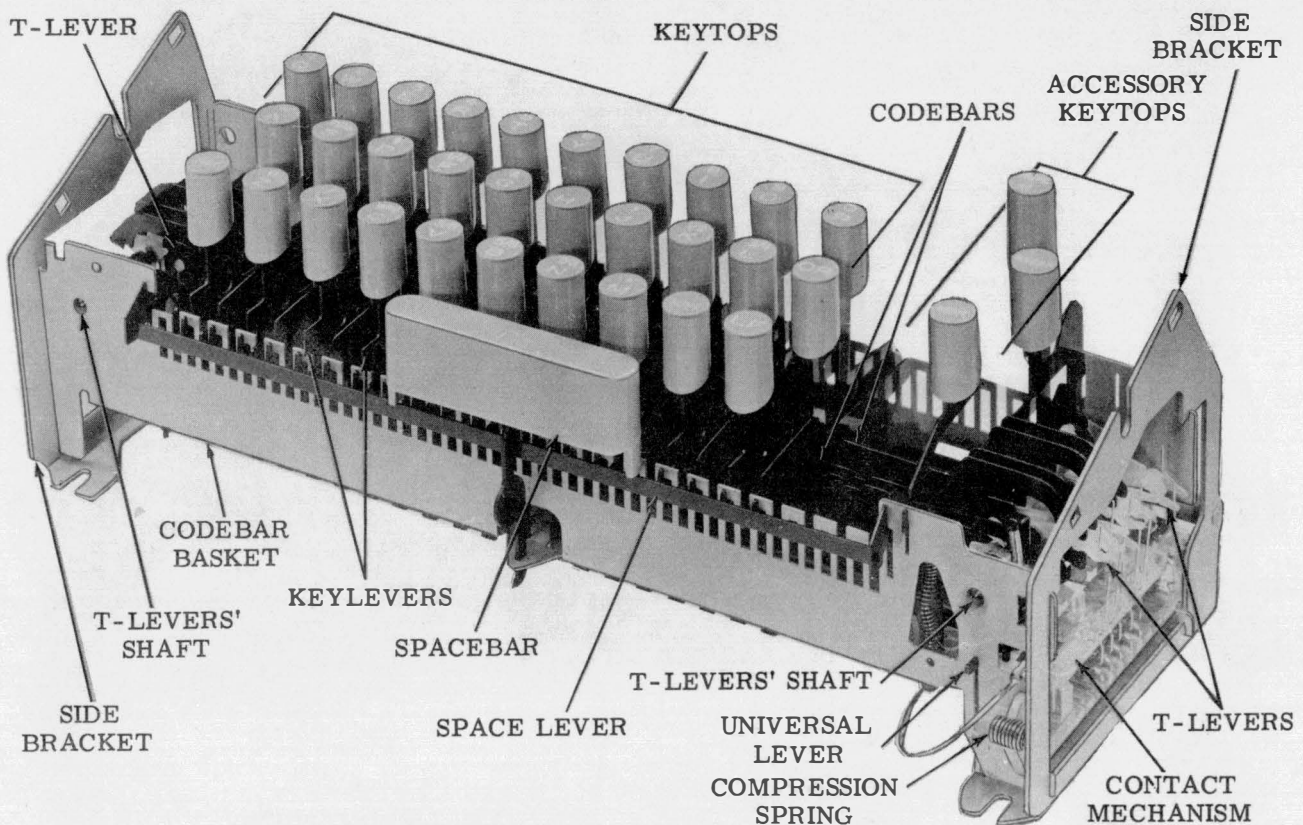

Figure 3 — Keyboard (Cover Removed)

rotation until the corresponding latchlever seats in its clutch disc notch. As a reminder, the word "latched" follows instructions to disengage the clutches.

1.13 A clutch is engaged when a trip lever is moved up so that it no longer holds a shoe lever in its stop position. When this action occurs, the shoe lever and a stop-lug on the clutch disc move apart, and the clutch shoes wedge against the drum, so that when the shaft is turned, the clutch will turn in unison with it.

1.14 General Maintenance Principles:

(a) Lubrication instructions and intervals are given in the appropriate lubrication sections.

(b) To maintain the operational effectiveness of the equipment, it is recommended that certain parts be replaced at intervals based upon the speed and operating hours, as indicated below:

Operating Speed (Words per Minute)	Recommended Maintenance Overhaul Interval (Operating Hours*)	Estimated Service Life (Operating Hours*)
60 or 66	2500	7500
100	1500	4500

*Typing Unit Operating Hours

The parts are available in overhaul maintenance kits listed in the appropriate parts publications.

2. BASIC UNIT

2.01 Universal Link

Note 1: This adjustment can be made more easily with the keyboard removed from the subbase. If it has not been previously removed, remove the keyboard and the call control unit now. For instructions, see the appropriate keyboard section.

Note 2: Disregard the instruction given in Note 1 when adjusting self-contained keyboards. However, remove the TP195481 cover which provides a protective-decorative enclosure for the self-contained keyboard. For instructions, see the appropriate keyboard section.

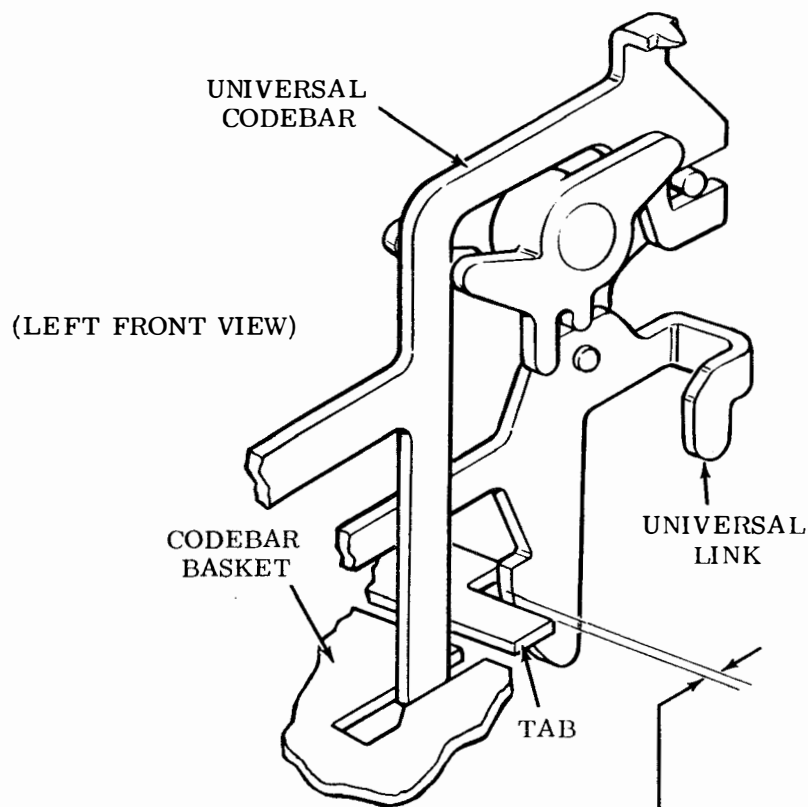

UNIVERSAL LINK

Requirement

With the universal lever latched in its down position

Min 0.089 inch---Max 0.103 inch
between the universal link and the codebar basket.

To Adjust

Place screwdriver through opening and bend tab on codebar basket.

2.02 Distributor Trip Linkage

Note 1: Replace keyboard onto subbase at this point. For instructions, see the appropriate keyboard section. Do not replace the call control unit.

Note 2: Disregard the instructions given in Note 1 and the adjusting procedures specified in the Distributor Trip Linkage adjustment when adjusting self-contained keyboards.

DISTRIBUTOR TRIP LINKAGE

To Check

With typing unit in stop condition, depress the RUB OUT key (8-level) or LTRS key (5-level) to trip distributor clutch. Rotate main shaft until the keyboard follower lever is moved to its lowest point by cam roller.

Note 3: Prior to gauging the required gap, push end of universal lever that protrudes through the front of codebar basket to bottom of its guide slot and allow it to snap up.

Requirement

Early design keyboards with universal lever TP180086:

Min 0.010 inch---Max 0.035 inch
between latchlever and universal lever.

Late design keyboards with universal lever TP182240:

Min 0.010 inch---Max 0.040 inch
between latchlever and universal lever.

To Adjust

With clampscrew loosened, position trip linkage adjusting bracket using slot in casting and pry points.

Related Adjustment

Affects

TRIP LEVER ENGAGEMENT

(See appropriate typing unit section.)

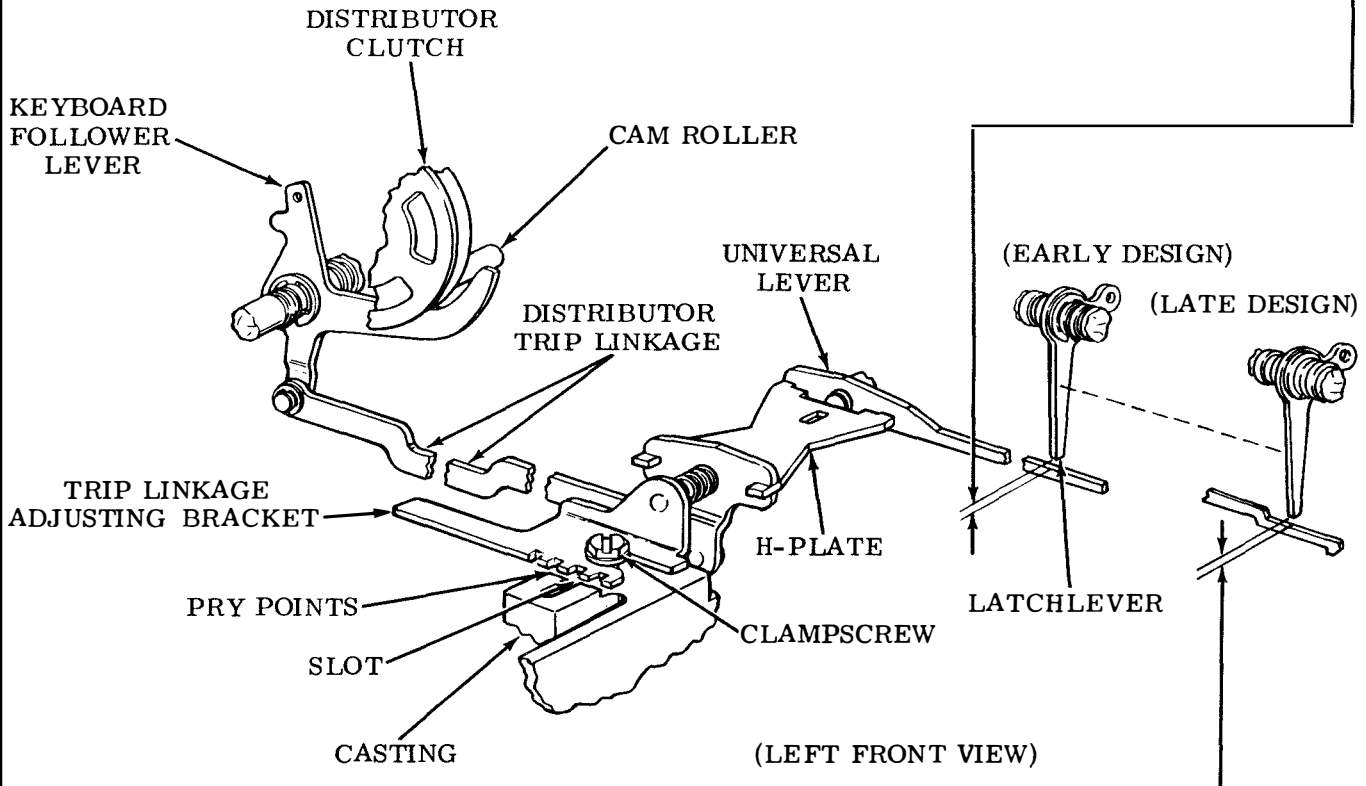

2.03 Contact Wires

CONTACT WIRES

- (1) To Check
 With the universal lever latched in its down position, place the T-levers down in marking position.

Requirement
 Min 0.008 inch---Max 0.027 inch
 between terminal and each TP180043
 contact wire.

To Adjust
 Bend contact wire TP180043 with
 bending tool no. TP98055.

Note 1: Do not adjust TP180070 and
 TP180101 contact wires.

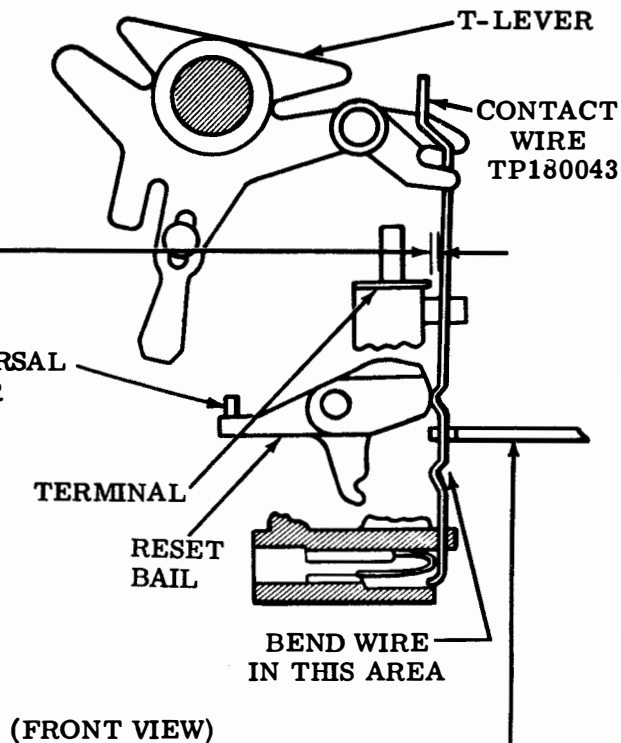

- (2) To Check
 With the universal lever latched in its down position, place T-levers up in spacing position. Place universal lever in up position by depressing universal codebar.

Requirement
 Min 0.020 inch---Max 0.040 inch
 between terminal and each TP180043
 contact wire.

To Adjust
 Bend contact wire TP180043 with
 bending tool no. TP98055.

Related Adjustment
 Affected By
 Part (2) of this adjustment is affected
 by Part (1).

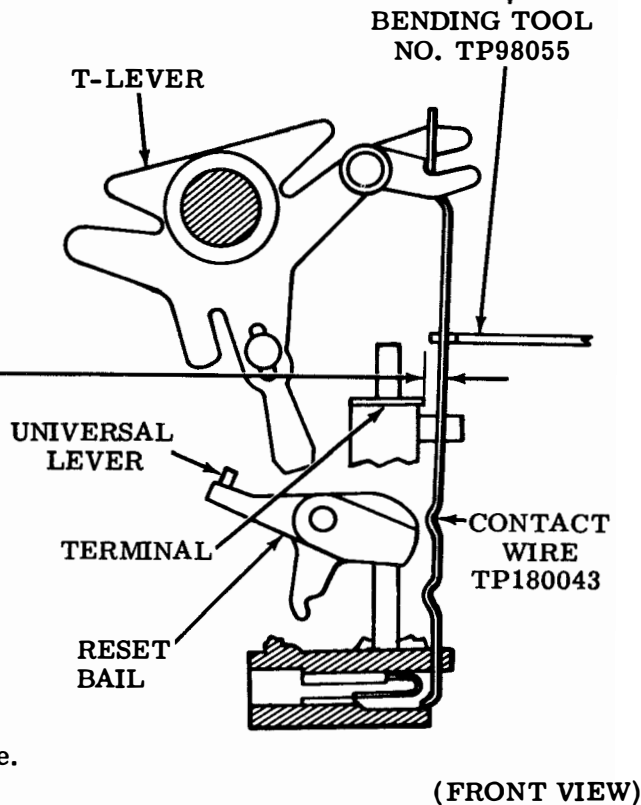

Note 2: If necessary, to facilitate the bending of the contact wires, remove the keyboard from the subbase. For instructions, see appropriate keyboard section. After bending contact wires, replace keyboard onto subbase and recheck DISTRIBUTOR TRIP LINKAGE adjustment.

Note 3: Disregard Note 2 when adjusting self-contained keyboards.

2.04 Nonrepeat Lever Spring, Latchlever Spring, Contact Block Spring, and Contact Wire Spring

NONREPEAT LEVER SPRING

Requirement

With keyboard cover removed and the universal lever latched in its down position
 Min 3/4 oz---Max 1-1/2 oz
 to start nonrepeat lever moving

Note 1: To facilitate making NONREPEAT LEVER SPRING adjustment, remove keyboard cover. (For instructions, see the appropriate keyboard section.)

LATCHLEVER SPRING

To Check

With call control unit removed, trip distributor clutch and rotate main shaft until keyboard follower lever is moved by cam roller to its lowest point.

Note 2: Disregard the above Latchlever Spring "To Check" procedure when adjusting self-contained keyboard. Instead, hold the universal lever away from latchlever.

Requirement

Min 1/2 oz---Max 1 oz
 to start latchlever moving.

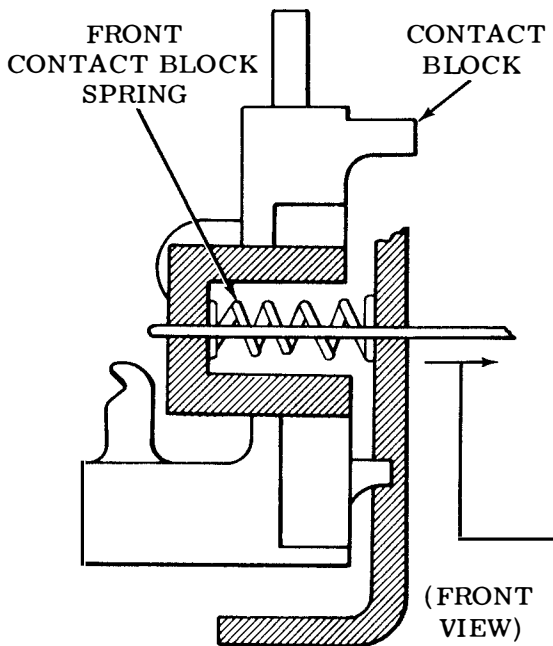
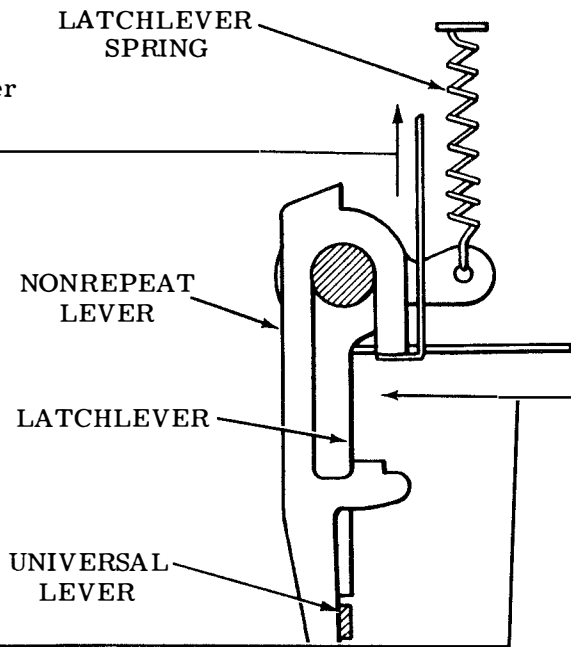

CONTACT BLOCK SPRING

Requirement

With call control unit removed
 Min 18 oz---Max 42 oz
 to start contact block moving.

Note 3: Check both front and rear contact block springs.

Note 4: Disregard instructions calling for the removal of the call control unit when adjusting self-contained keyboards.

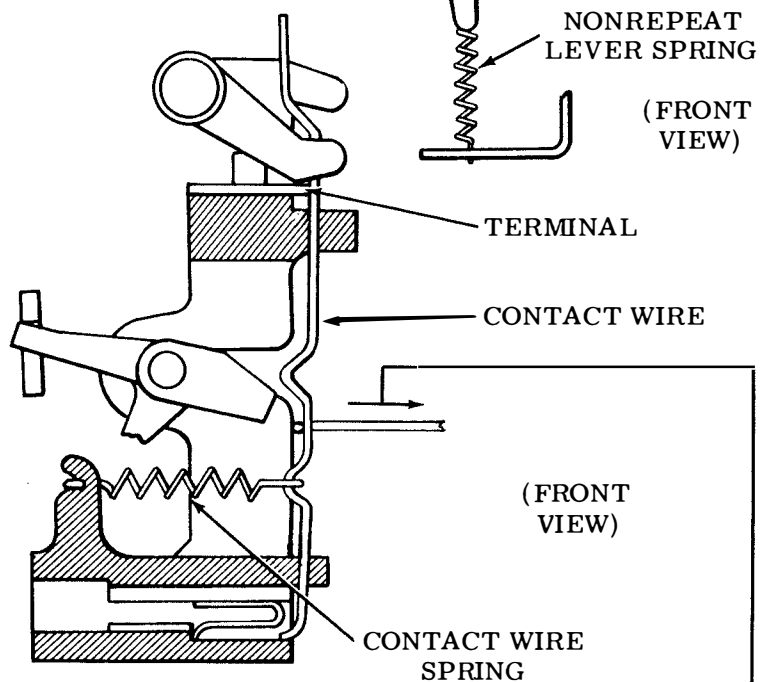

CONTACT WIRE SPRING

To Check

With call control unit removed, place T-levers in down (marking) position. Trip keyboard by depressing universal codebar.

Requirement

Min 3/4 oz---Max 1-1/4 oz
 to start each contact wire moving away from terminal.

2.05 Reset Bail Spring and Universal Link Spring

RESET BAIL SPRING

To Check

With keyboard cover removed, trip keyboard by depressing LTRS (5-level) or RUB OUT (8-level) keytop.

Requirement

Min 1-1/2 oz---Max 2 oz to start reset bail moving.

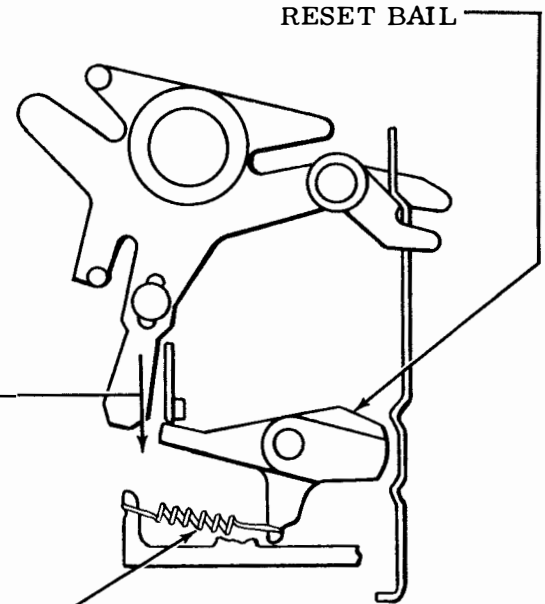
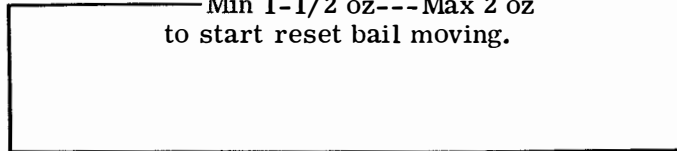

RESET BAIL SPRING

(FRONT VIEW)

UNIVERSAL LINK SPRING

Requirement

With keyboard tripped (universal lever in up position)

Min 1/2 oz---Max 1-1/4 oz to start universal link moving.

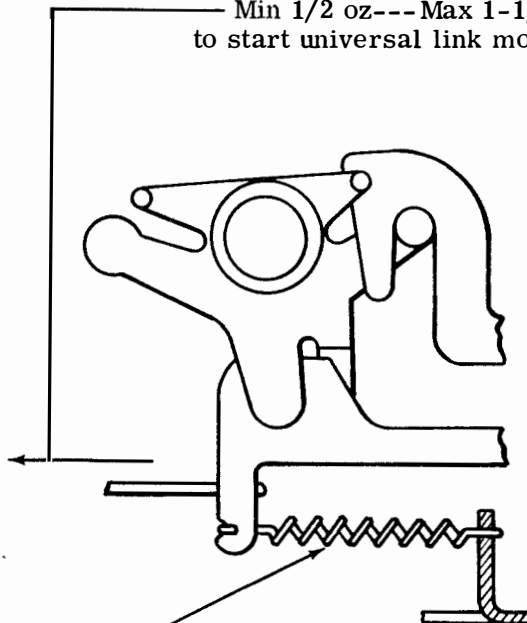

UNIVERSAL LINK SPRING

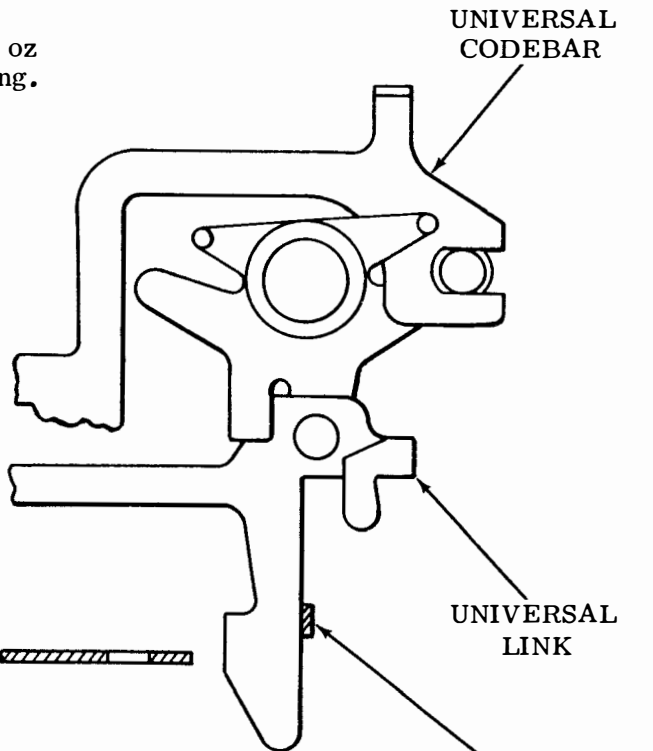

UNIVERSAL CODEBAR

UNIVERSAL LINK

UNIVERSAL LEVER

(FRONT VIEW)

2.06 Universal Lever Spring

UNIVERSAL LEVER SPRING

To Check

With keyboard cover removed, latch the universal lever in its down position. Remove H-plate, if used. (See the appropriate keyboard section.)

Requirement

All except self-contained keyboards:
Min 1/2 oz---Max 1-1/2 oz

Self-contained keyboards:
Min 15 oz---Max 17 oz
to pull spring to its installed length.

Note 1: Self-contained keyboards do not use an H-plate.

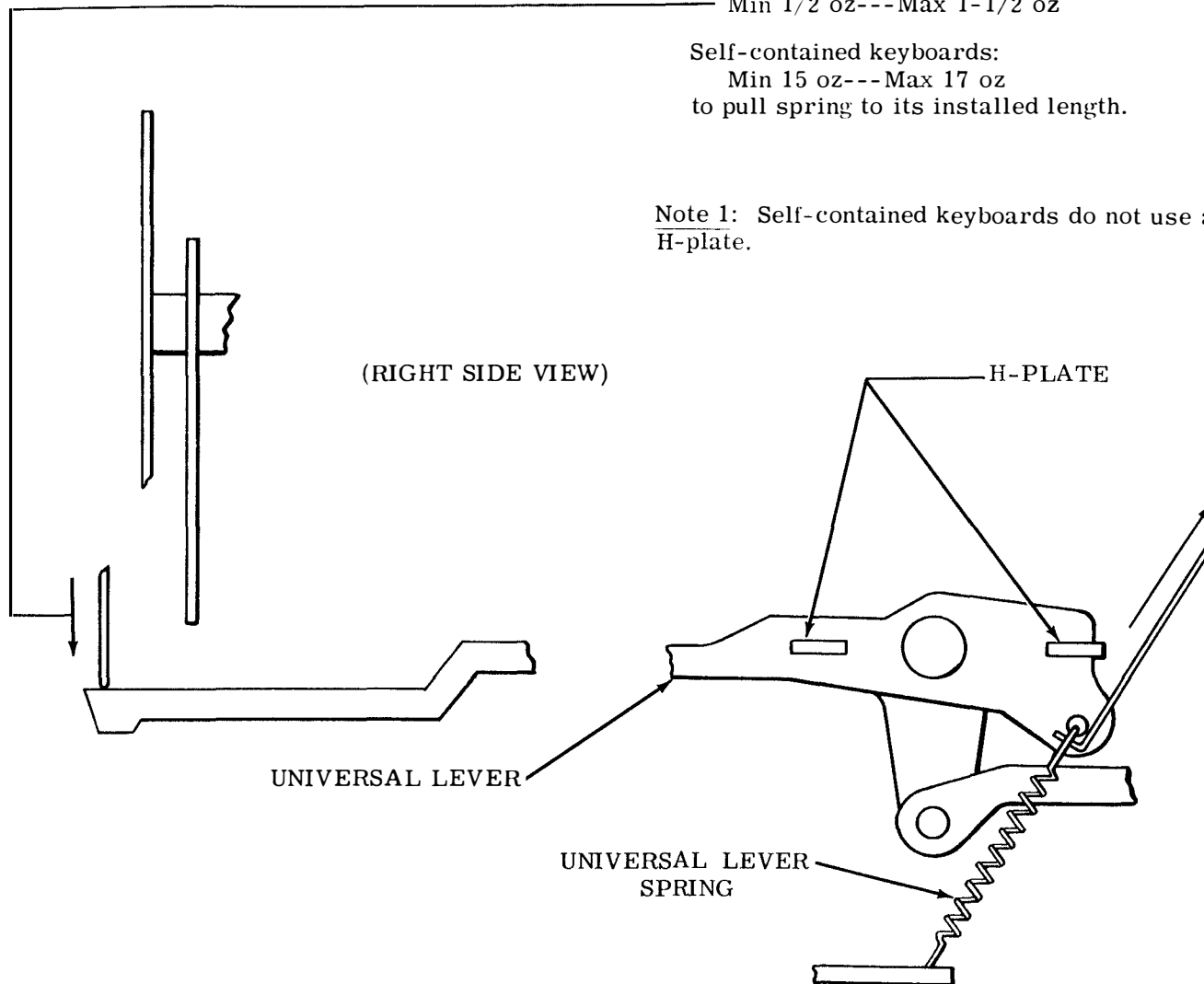

Note 2: Replace call control unit onto subbase. Also replace keyboard cover and H-plate. For instructions, see the appropriate section.

Note 3: For self-contained keyboards, disregard Note 2 and substitute the following: Replace keyboard cover. For instructions, see appropriate keyboard section.

2.07 Spacebar Spring and Keylever Spring

SPACEBAR SPRING

To Check

Depress spacebar once and then release.
Place a scale on the spacebar.

Requirement

Min 5 grams---Max 25 grams
to start spacebar moving.

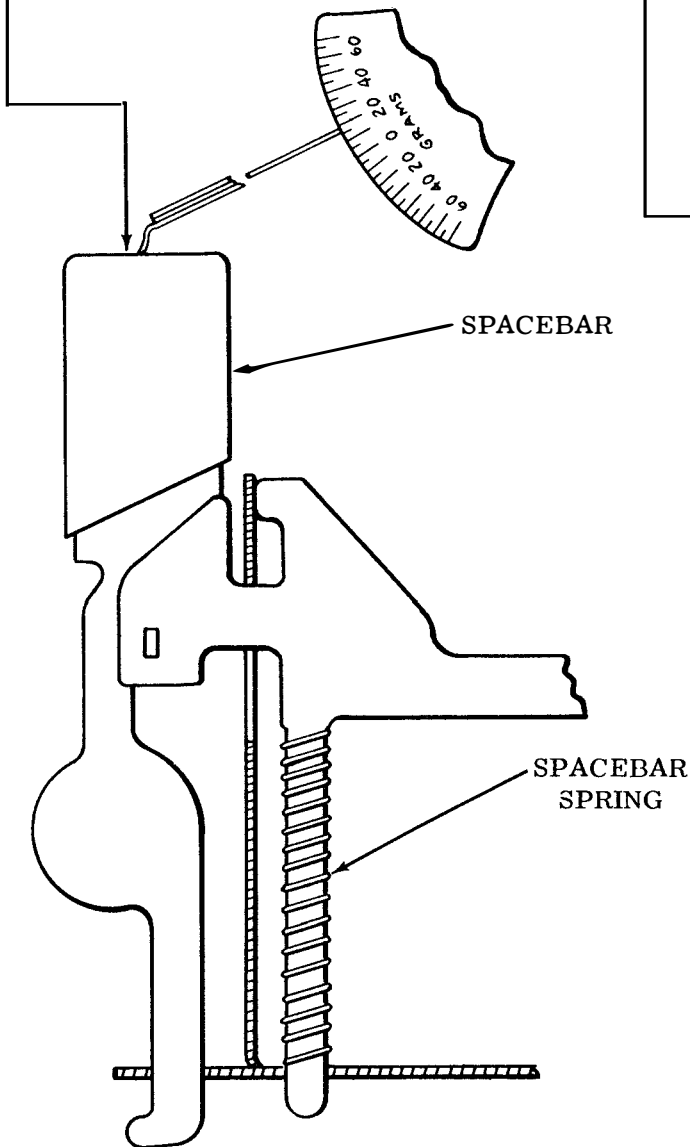

(RIGHT SIDE VIEW)

KEYLEVER SPRING

To Check

Select any keytop and depress. Release key-
top. Place a scale on the same keytop.

Requirement

Min 5 grams---Max 25 grams
to start selected keytop moving.

Note: Check each keylever spring in a like
manner.

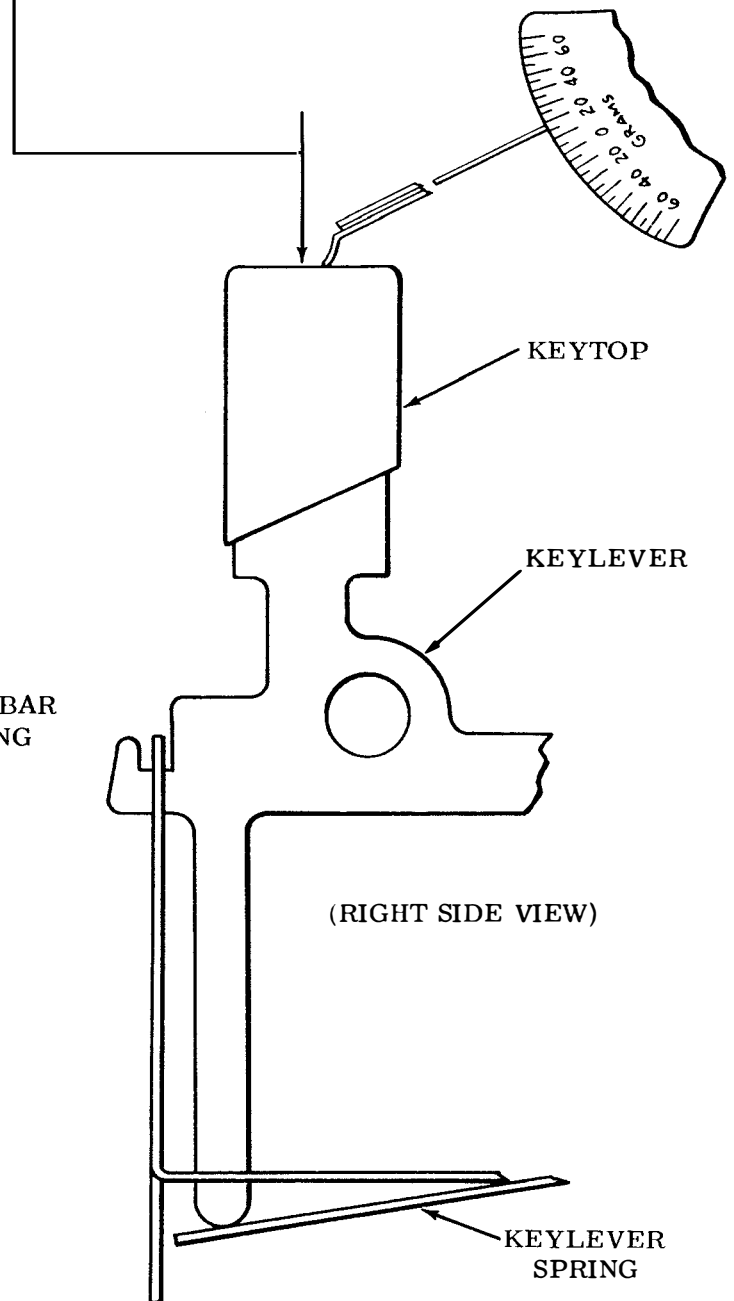

(RIGHT SIDE VIEW)

2.08 HERE IS, BREAK, CTRL,
and REPT Keylever Springs

"BREAK" KEYLEVER SPRING

Requirement

5-level:

Min 12 oz---Max 18 oz

8-level:

Min 4-1/2 oz---Max 10 oz
to start keytop moving.

"CTRL" KEYLEVER SPRING

Requirement

8-level:

Min 1-1/2 oz---Max 3-1/2 oz
to start keytop moving.

"HERE IS" KEYLEVER SPRING

Requirement

Min 18 grams---Max 35 grams
to start keytop moving.

"REPT" KEYLEVER SPRING

Requirement

Min 15 grams---Max 30 grams
to start keytop moving.

(RIGHT SIDE VIEW)

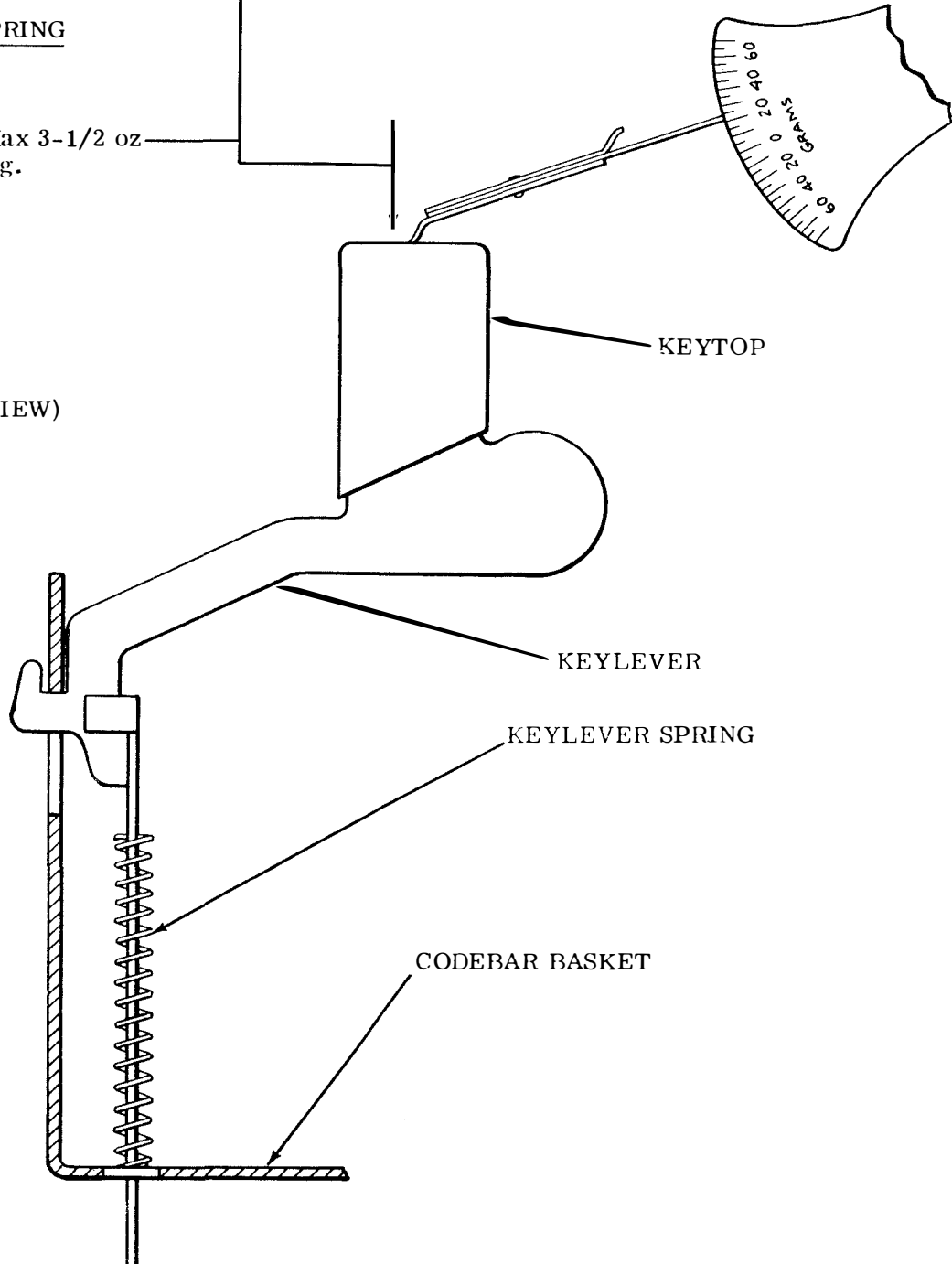

2.09 Shift Codebar Spring

Note: The SHIFT CODEBAR SPRING adjustment applies only to 8-level keyboards.

SHIFT CODEBAR SPRING

Requirement

With "even parity":

Min 2 oz---Max 3-1/4 oz

Without "even parity":

Min 1-1/4 oz---Max 2-1/2 oz

to start shift codebar link moving.

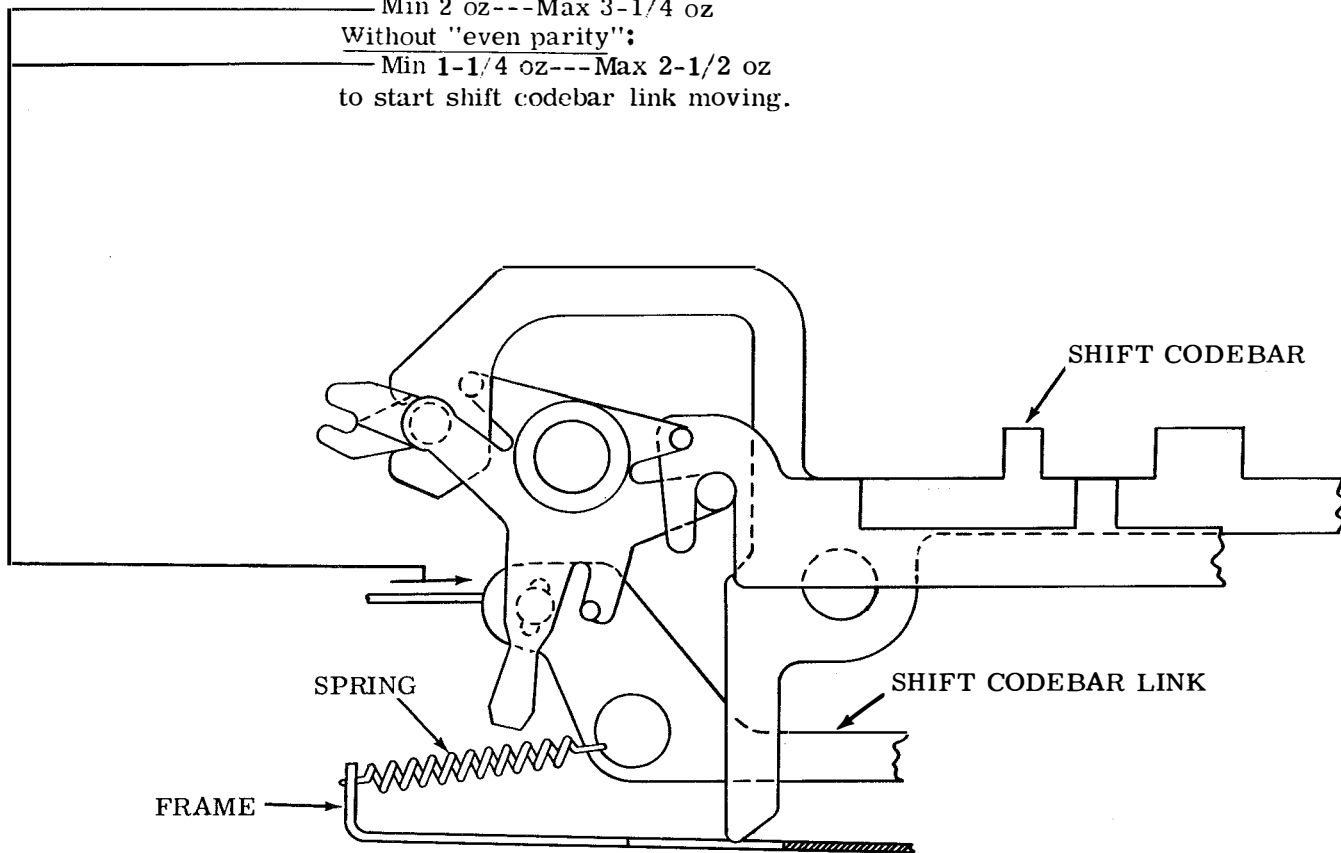

(FRONT VIEW)

3. VARIATIONS TO BASIC UNITS

3.01 Reset Solenoid Position and Reset Arm

RESET SOLENOID POSITION

Requirement

Plunger should move freely without binding in reset solenoid core.

To Adjust

Position reset solenoid with mounting screws loosened.

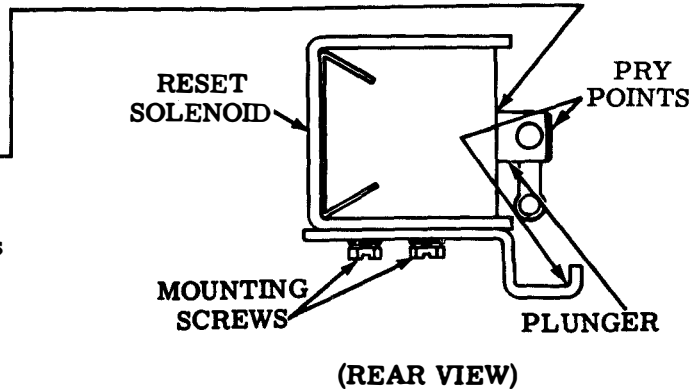

RESET ARM

To Check

Place the reset solenoid plunger to its fully energized position and, using pry points, hold it there.

Requirement

Min 0.020 inch—Max 0.045 inch—
between universal lever and latchlever.

To Adjust

Loosen reset arm clampscrew. With reset solenoid plunger in its fully energized position, place reset arm so as to meet requirement.

Note: When tightening reset arm clampscrew, take care not to bind reset arm against mounting bracket.

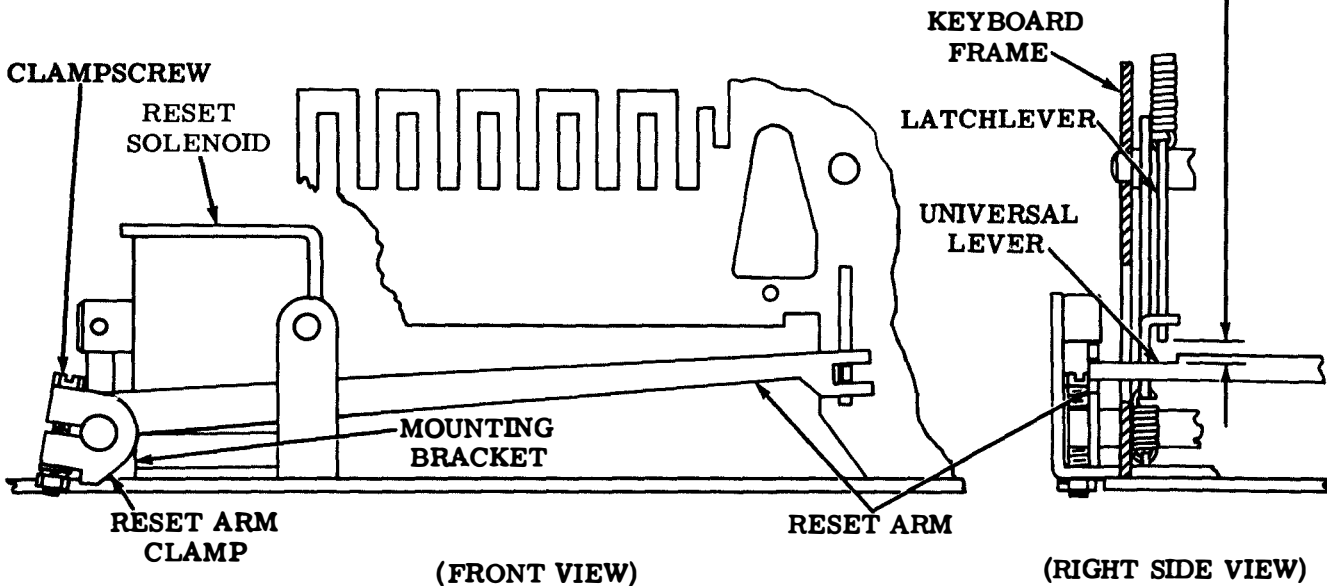

3.02 Universal Contact

UNIVERSAL CONTACT

To Check

Move the universal contact wire from the guide slot formed by the insulator projections and place it opposite the terminal.

Requirement

With the universal lever latched in its down position

Min 0.040 inch---Max 0.050 inch between the universal contact wire and terminal.

To Adjust

Bend the universal contact wire with bending tool no. TP98055.

Note: After making the adjustment, replace the universal contact wire into the guide slot formed by the insulator projections.

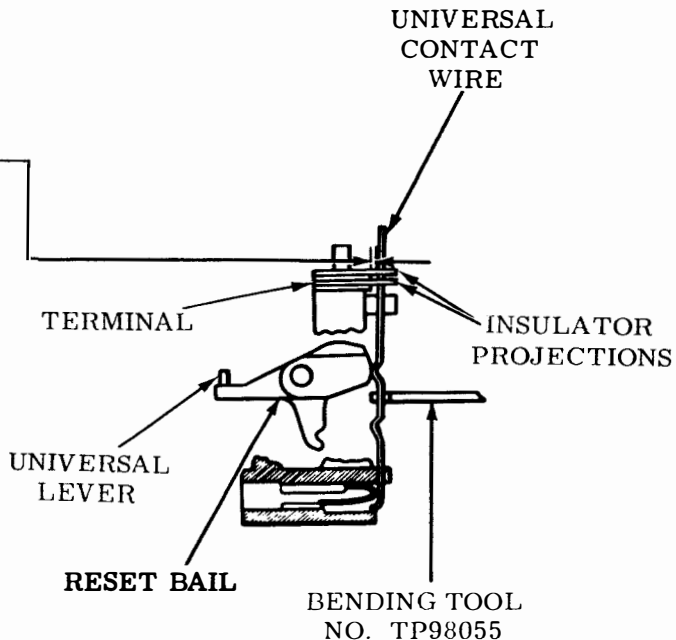

(FRONT VIEW)



REPLACING PAGE ADDENDUM

Filing Instructions:

1. Remove from the section the pages numbered the same as those attached to this addendum.
2. Insert the attached pages into the section in their place.
3. Place this addendum ahead of Page 1 of the section.

32 AND 33 KEYBOARD

LUBRICATION

1. GENERAL

1.001 This addendum supplements section 574-121-701TC, Issue 1. The attached pages must be inserted in the section in accordance with the filing instructions above.

1.002 This addendum is issued to add information not included in Issue 1 of the section.

1.003 Make the following changes or additions:

(a) Page 1, Contents, add:

3. VARIATIONS TO BASIC UNIT.	5
Self-contained keyboard.	5
Solenoid reset mechanism	5
Universal lever	5

(b) Page 1, change 1.03 to read as follows:

1.03 Thoroughly lubricate the keyboard, but avoid over lubrication that might permit the lubricant to drip or be thrown onto adjacent parts. Use KS7470 oil where oil is required and KS7471 grease where grease is required.

Attached:

- Page 1 dated September 1964, revised
- Page 2 dated September 1964, reissued
- Page 3 dated September 1964, reissued
- Page 4 dated September 1964, revised
- Page 5 dated September 1964, added

(c) Page 1, change 1.05 abbreviated directions (symbols) as follows:

<u>Symbol</u>	<u>Meaning</u>
D	Keep dry - no lubricant permitted
G	Apply a thin coat of KS7471 grease
O4	Four drops of oil
OL	Oil liberally (3 or more drops)
OS	Oil sparingly (1 or 2 drops only)
OSAT	Saturate with oil (felt washers and oilers)
OSD	Oil sparingly or leave dry **
OSL	Oil sparingly or liberally

32 AND 33 KEYBOARD

LUBRICATION

CONTENTS	PAGE
1. GENERAL	1
2. BASIC UNIT	2
Codebar mechanism	4
Contact block	3
HERE IS, BREAK, and REPT keylevers	3
Keyboard	2
Keylevers	2
Latchlever hooks	3
Reset bail	4
Spacebar	2
Universal lever	4

<u>Operating Speed</u> (Words per Minute)	<u>Lubrication</u> <u>Interval</u>
60 or 66	1000 hr* or 1 yr**
100	500 hr* or 6 mo**

*Station Set operating hours.
 **Whichever comes first.

1.05 The textual instructions that accompany each line drawing consist of abbreviated directions, specific lubrication points, and parts affected. The meanings of the abbreviated directions (symbols) are given below:

<u>Symbol</u>	<u>Meaning</u>
D	Keep dry - no lubricant permitted
OL	Oil liberally (3 or more drops)
OS	Oil sparingly (1 or 2 drops only)
OSD	Oil sparingly or leave dry**
OSL	Oil sparingly or liberally

**Applies to all areas not contacted by other parts.

1.06 References to "left," "right," "front," or "rear," etc consider the keyboard to be viewed from a position where the spacebar faces up and the contact mechanism is located to the viewer's right.

CAUTION: DO NOT USE ALCOHOL, MINERAL SPIRITS, OR OTHER SOLVENTS TO CLEAN PLASTIC PARTS OR PARTS WITH PROTECTIVE-DECORATIVE FINISHES. NORMALLY, A SOFT, DRY CLOTH SHOULD BE USED TO REMOVE DUST, OIL, GREASE, OR OTHERWISE CLEAN PARTS OR SUBASSEMBLIES. IF NECESSARY, A SOFT CLOTH DAMPENED WITH SOAP OR MILD DETERGENT MAY BE USED. AFTERWARDS, RINSE PART OR SUBASSEMBLY WITH A SOFT, DAMP CLOTH AND BUFF WITH A SOFT, DRY CLOTH.

1. GENERAL

1.01 This section is issued to provide instructions for lubricating the 32 and 33 keyboard and to present the lubricating instructions as a separate section.

1.02 The general lubrication areas are illustrated by a photograph. The specific points to receive lubricant are indicated on line drawings with appropriate textual instructions. The line drawings and textual instructions follow the photograph and are keyed to the photograph by paragraph numbers.

1.03 Thoroughly lubricate the keyboard, but avoid over lubrication that might permit the lubricant to drip or be thrown onto adjacent parts. Use KS7470 Oil.

1.04 Lubricate the keyboard before placing it into service or prior to storage. After a short period of service, relubricate it to make sure no areas have been missed. Thereafter, lubricate the keyboard at regular intervals as indicated:

2. BASIC UNIT

2.01 Keyboard

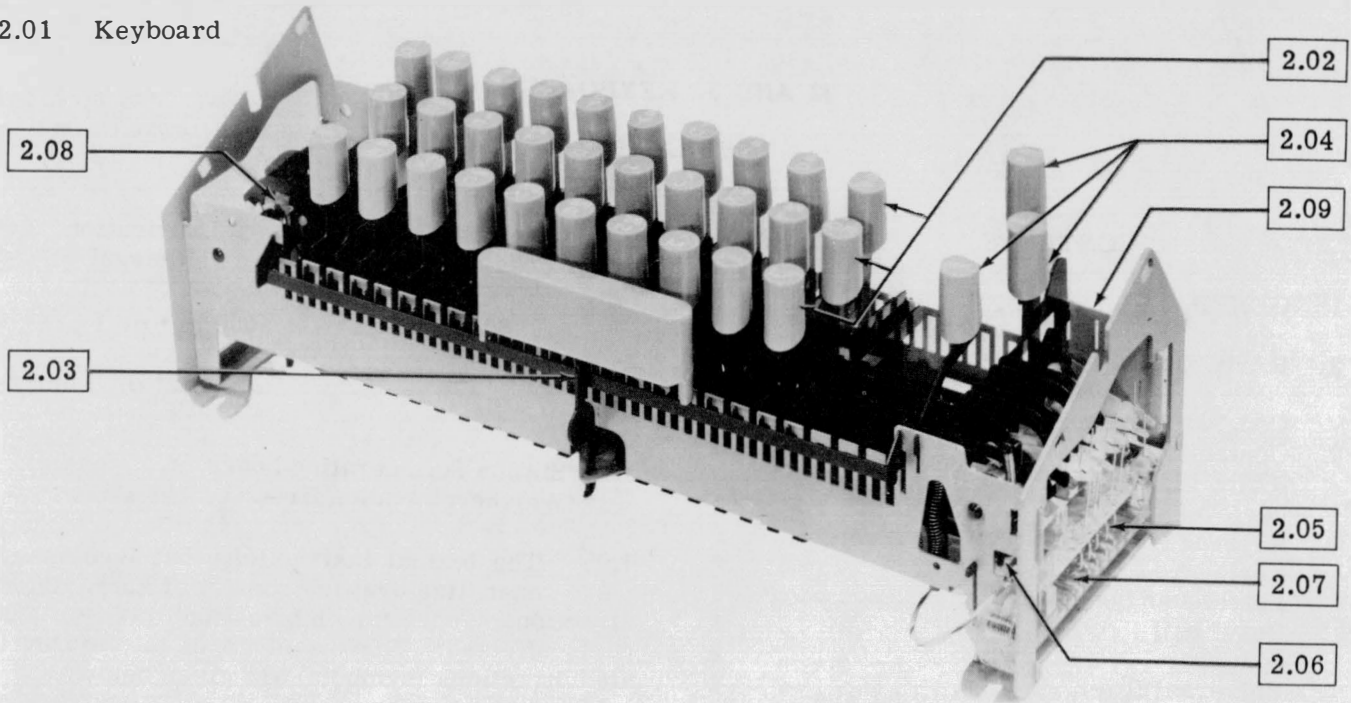

(KEYBOARD - COVER REMOVED - RIGHT FRONT VIEW)

2.02 Keylevers

2.03 Spacebar

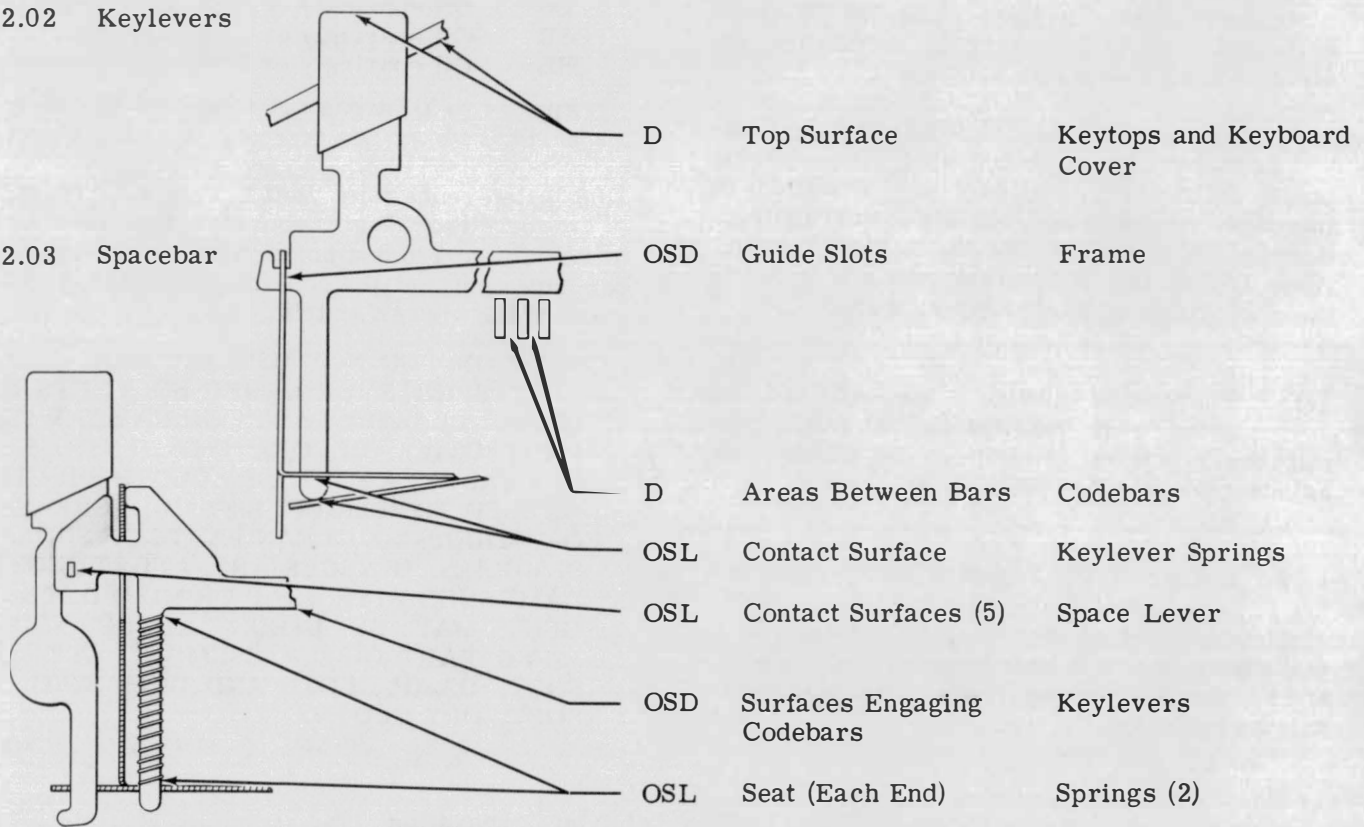

(RIGHT SIDE VIEW)

2.04 HERE IS, BREAK, and REPT Keylevers

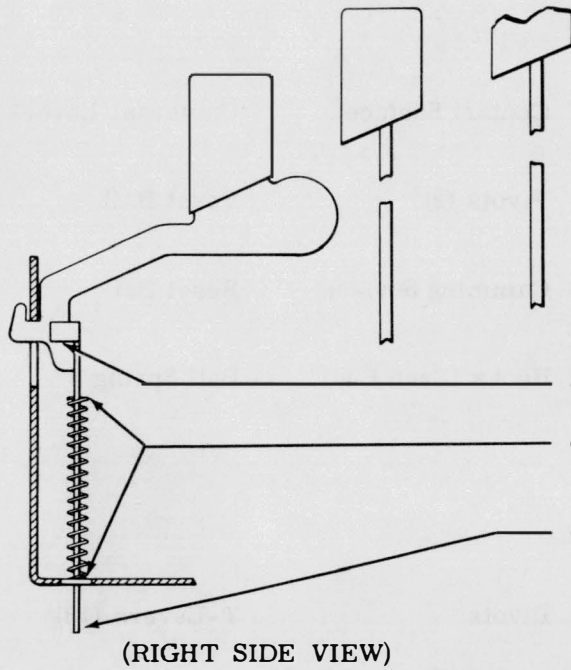

- OSL Contact Surfaces Keylevers
- OSL Seat (Each End) Springs (3)
- OSL Contact Point BREAK Keylever

CAUTION: DO NOT CLEAN THE KEYBOARD CONTACT BLOCK WITH ALCOHOL, MINERAL SPIRITS, OR OTHER SOLVENTS.

2.05 Contact Block

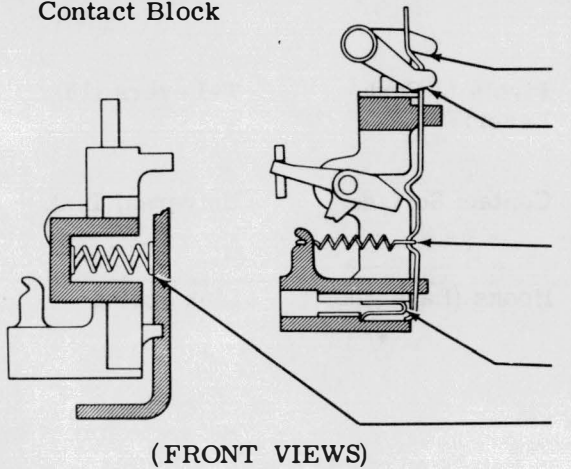

- OSD Engaging Surfaces T-Levers (6)
- D Contact Surface Contact Wires (6)
- D Springs (6) Contact Wires
- D Contact Surface Contact Wires (6)
- OSL Seat (Each End) Springs (2)

2.06 Latchlever Hooks

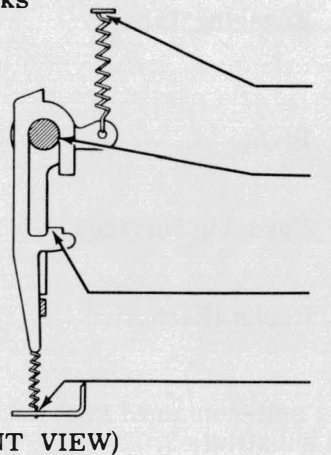

- OSL Hooks (Each End) Latchlever Spring
- OSL Pivot Latchlever and Nonrepeat Lever
- OSL Contact Surface Latchlever
- OSL Hooks (Each End) Nonrepeat Spring

2.07 Reset Bail

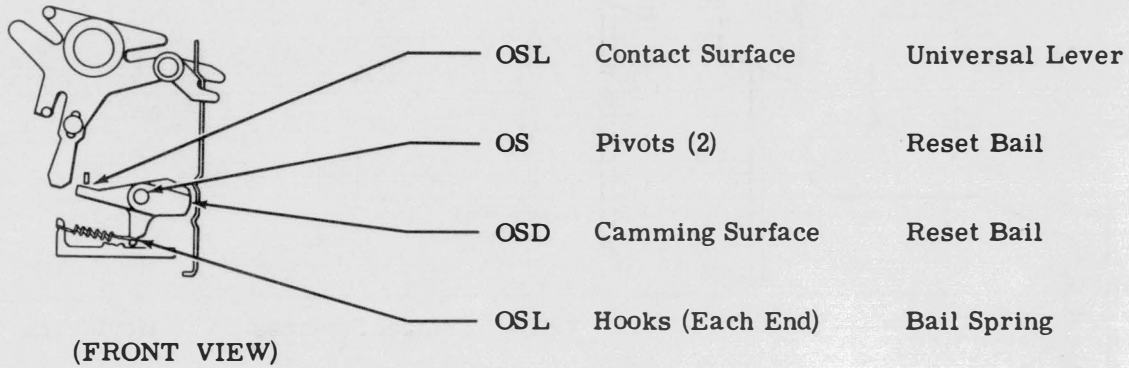

2.08 Codebar Mechanism

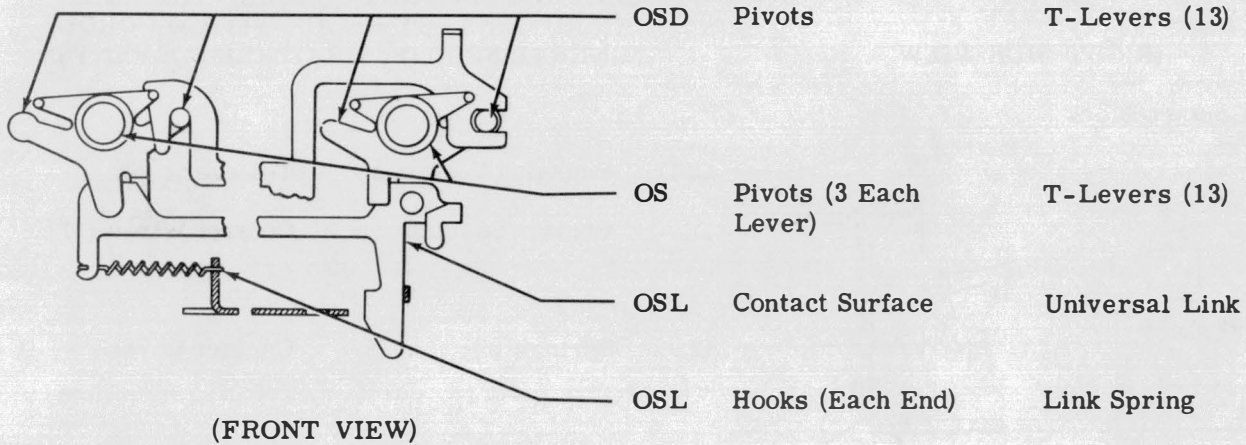

2.09 Universal Lever

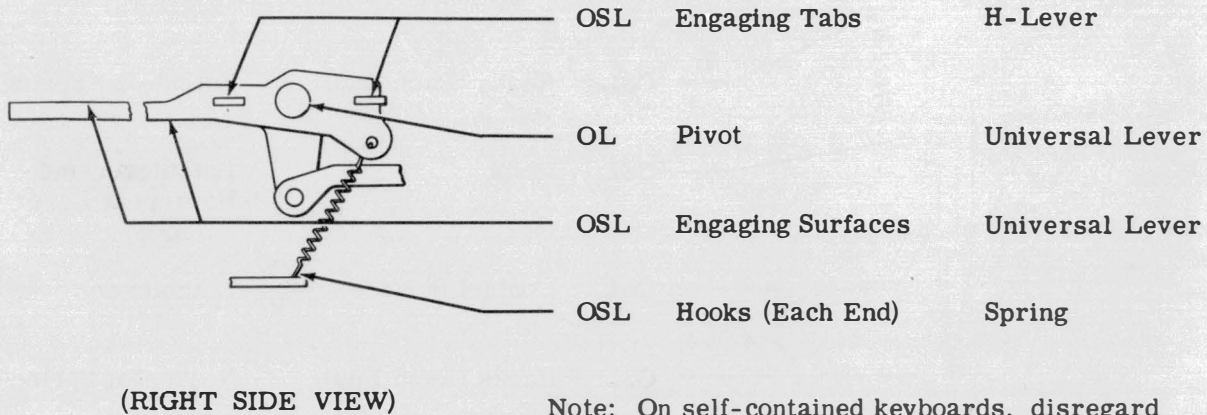

Note: On self-contained keyboards, disregard 2.09 and substitute 3.02.

3. VARIATIONS TO BASIC UNIT

3.01 Self-Contained Keyboard

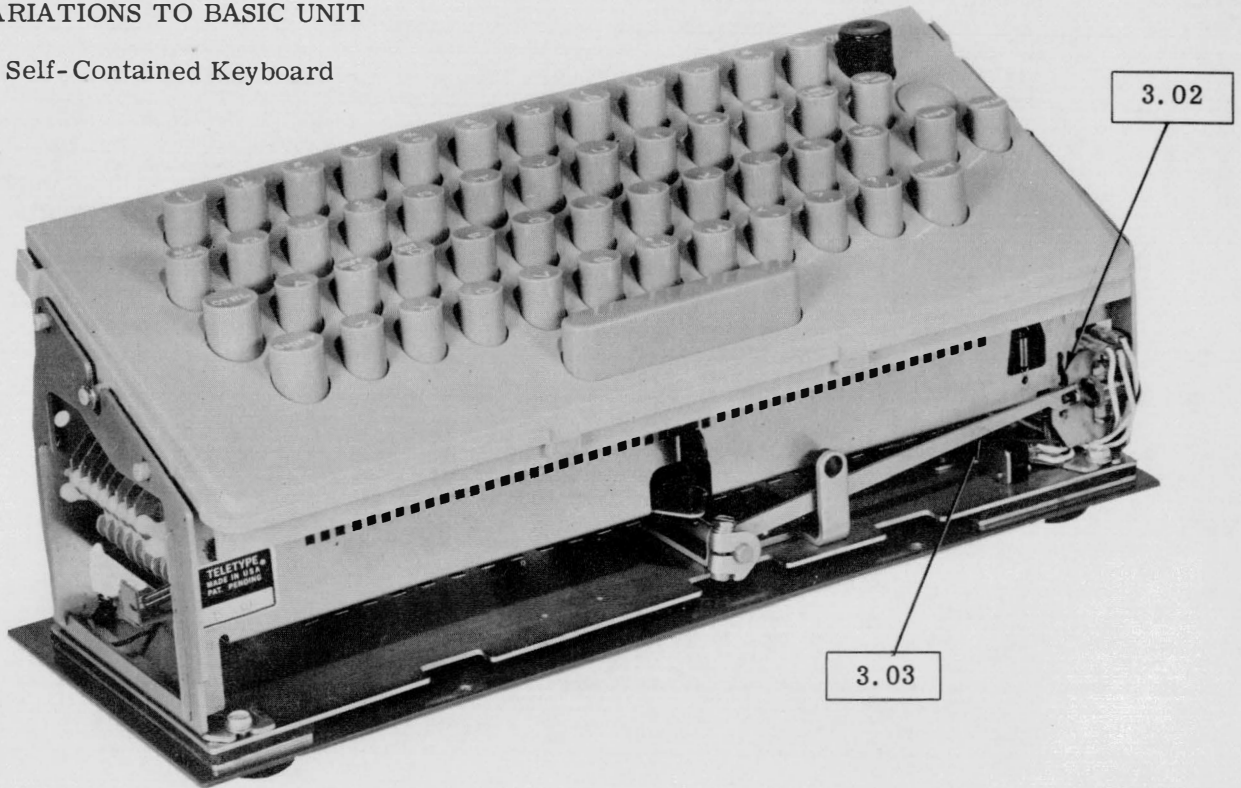

(LEFT FRONT VIEW)

3.02 Universal Lever

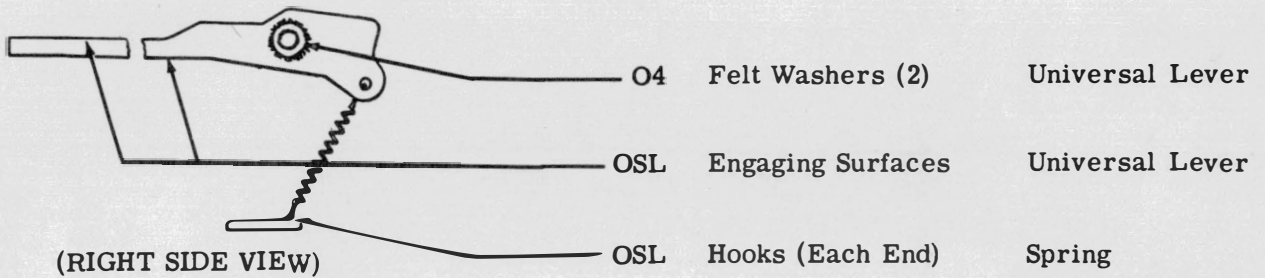

(RIGHT SIDE VIEW)

3.03 Solenoid Reset Mechanism

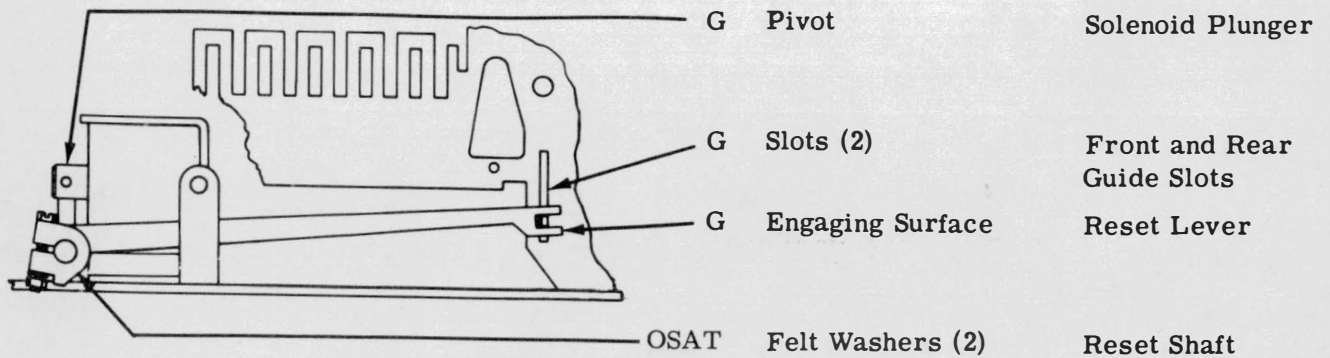

(FRONT VIEW)

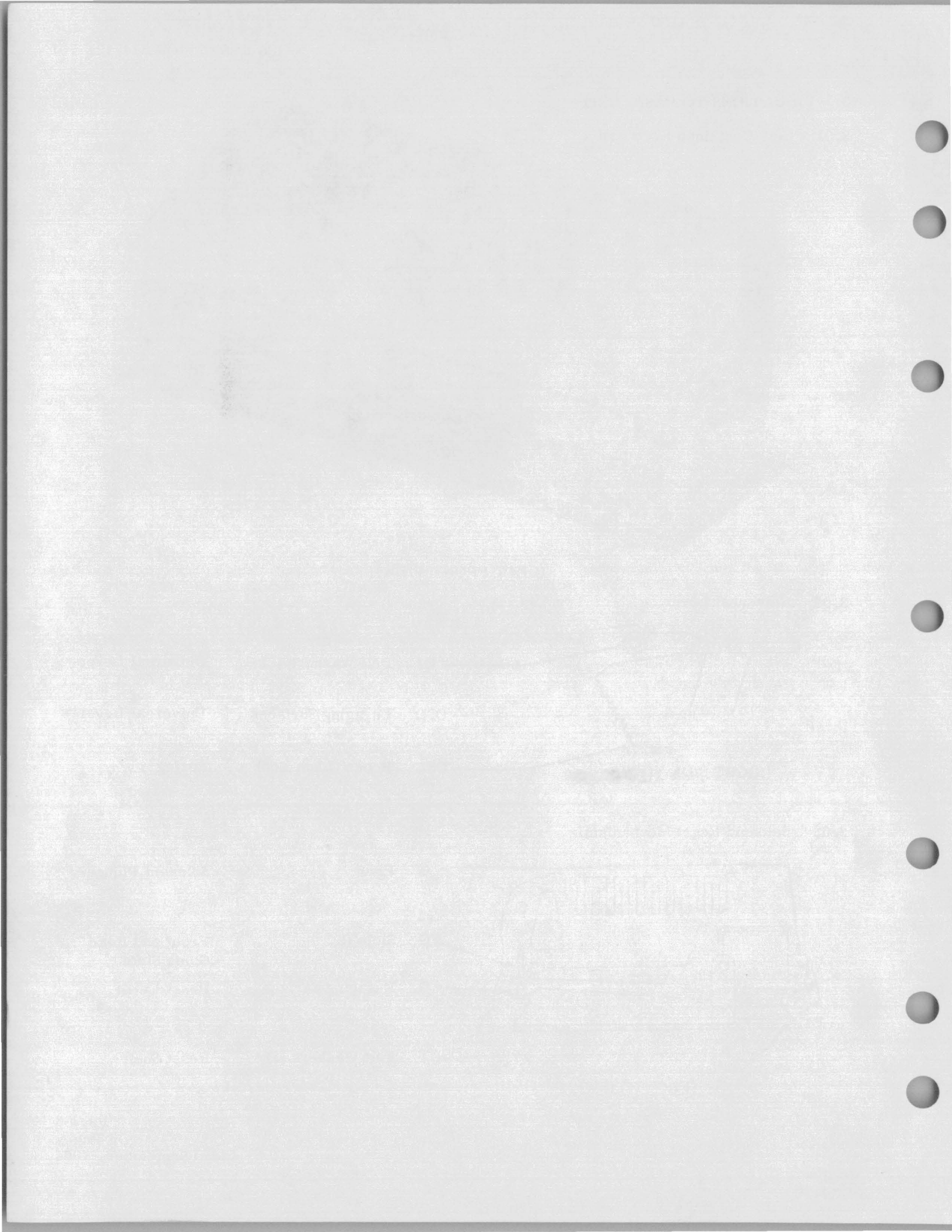

REPLACING PAGE ADDENDUM

Filing Instructions:

1. Remove from the section the pages numbered the same as those attached to this sheet.
2. Insert the attached pages in the section in their place.
3. Place this sheet ahead of Page 1 of the section.

32 AND 33 KEYBOARD

DISASSEMBLY AND REASSEMBLY

1. GENERAL

1.001 This addendum supplements 574-121-702TC, Issue 1. The attached pages must be inserted in the section in accordance with the filing instructions above.

1.002 This addendum is issued to add information not included in Issue 1 of the section.

Attached:

Page 1 dated September 1964, revised
Page 2 dated September 1964, revised

32 AND 33 KEYBOARD

DISASSEMBLY AND REASSEMBLY

CONTENTS	PAGE
1. GENERAL	1
2. DISASSEMBLY AND REASSEMBLY . .	1

1. GENERAL

1.01 This section is issued to provide disassembly and reassembly instructions for the 32 and 33 keyboard and to present the instructions as a separate section.

1.02 References to "left," "right," "front," "rear," etc consider the keyboard to be viewed from a position where the spacebar faces up and the contact mechanism is located to the viewer's right.

1.03 The disassembly procedure given in this section will break the keyboard down into its major assemblies and mechanisms. If further disassembly is required, refer to the appropriate illustrated parts section which shows detailed arrangements of parts. Where it will help in determining their location, the numbers of the parts are given in the instructions.

2. DISASSEMBLY AND REASSEMBLY

CAUTION: BEFORE BEGINNING DISASSEMBLY, REMOVE CONNECTORS FROM EXTERNAL RECEPTACLES (POWER SOURCE, DATA SET, ETC).

2.01 General:

(a) When self-tapping screws are used to mount mechanisms onto castings, do not remove the self-tapping screws. Merely loosen them enough to remove the mechanisms unless specifically instructed otherwise.

(b) Retaining rings are made of spring steel and have a tendency to release suddenly. To avoid loss of these rings when removing them, proceed as follows:

- (1) Hold retaining ring to prevent its rotating.
- (2) Place blade of screwdriver in one of ring's slots and rotate screwdriver to increase diameter.
- (3) Ring will come off easily in fingers without flying.

2.02 To remove keyboard and call control unit, proceed as follows:

Note: Reference Figures 1 and 2.

- (1) Remove the plastic protective cover from the Teletypewriter Set. For instructions, see the appropriate cover section.

Note: For self-contained keyboards, remove four TP181241 screws with flat washers from the bottom of the self-contained keyboard to be disassembled. Carefully remove the TP195481 cover and set it aside.

- (2) Remove the keyboard plug from its receptacle on the call control unit.
- (3) Remove four TP121551 mounting screws and remove call control unit.
- (4) Disengage keyboard cable from TP182531 cable clips on subbase.
- (5) Insert screwdriver in slot in TP180977 H-plate and push to left against pressure of spring until H-plate is disengaged from universal lever. Remove H-plate.

Note: If the typing unit has been removed from its seat on the subbase, the H-plate will already have been removed.

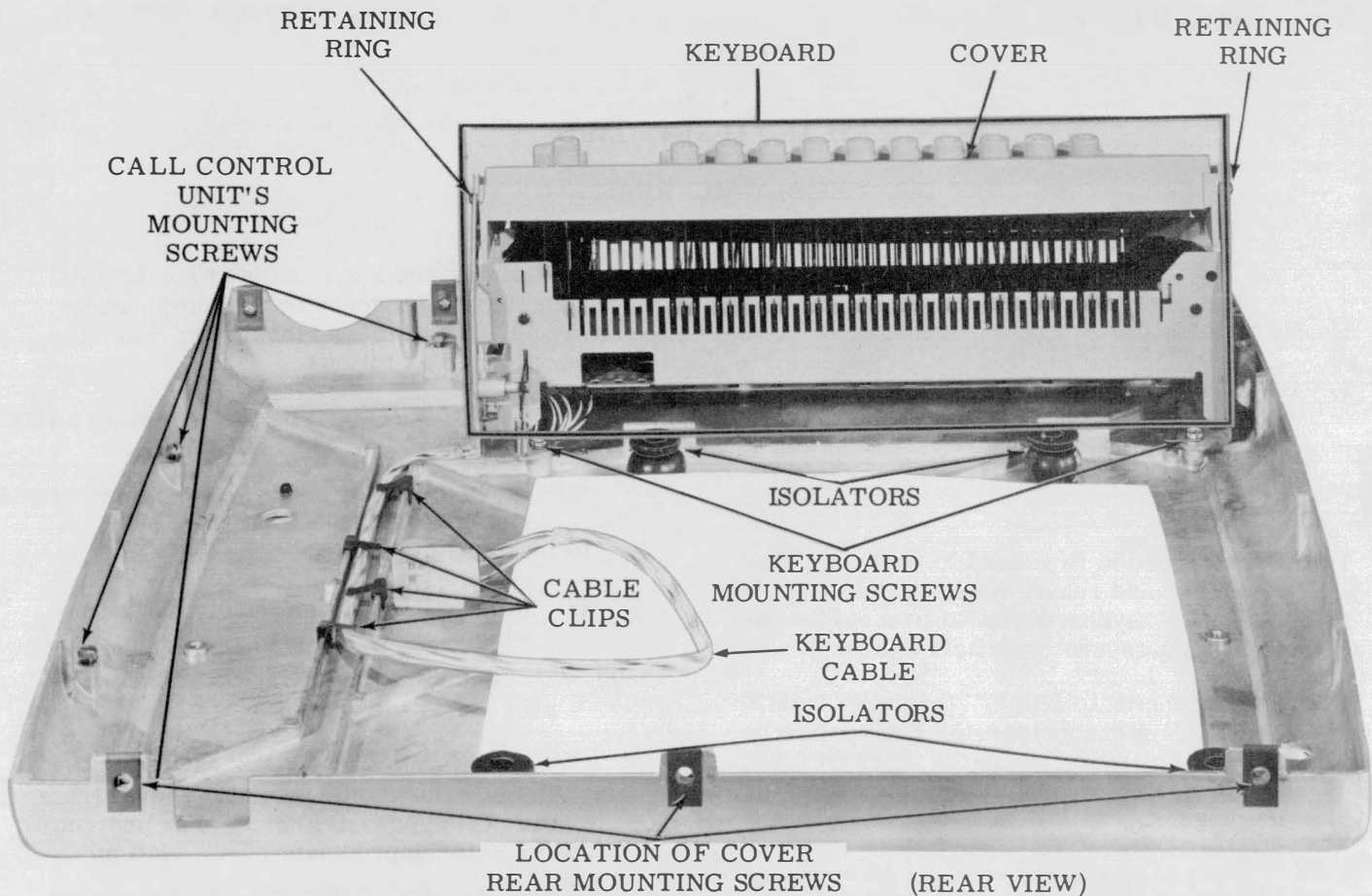

Figure 1 - Subbase with Keyboard

- (6) Loosen two TP180798 keyboard mounting screws. Slide keyboard assembly to rear and lift it from subbase.
- (7) To replace keyboard, reverse procedure used to remove it.

CAUTION: MAKE SURE THAT PLUG IS MATED WITH SIMILARLY DESIGNATED RECEPTACLE

- 2.03 To remove keyboard cover, proceed as follows:

Note: Reference Figures 1 and 2.

- (1) Remove TP119652 retaining ring from left side of keyboard cover, and rotate left side bracket away.
- (2) Hold right side bracket firmly in place against two TP180031 compression springs of keyboard contact mechanism, and remove TP119652 retaining ring from right side of keyboard cover.
- (3) Continue to hold right side bracket firmly in place, and disengage keyboard cover from right side bracket by moving it up and to the left. Lift keyboard cover off keys.

Note: With keyboard cover removed, right side bracket may be unexpectedly pushed away

from its assembled position due to spring load of two compression springs. If this happens, certain parts will prematurely fall loose. To prevent this, always keep right side bracket firmly against the two compression springs of keyboard contact mechanism, ie, either hold right side bracket in place by hand or butt it up against a fixed vertical surface.

- (4) To replace keyboard cover, reverse the procedure used to remove it.

- 2.04 To remove miscellaneous parts, proceed as follows:

- (1) To remove any keylever depress front end of TP180086 universal lever. Depress keylever, disengage it from front or rear guide slot, and lift it out of keyboard frame.

Note: Certain levers have compression springs on their lower stems so that the springs may be properly replaced during re-assembly.

- (2) To remove spacebar mechanism, remove spacebar with attached keylever. Bow TP180056 space lever and disengage it from

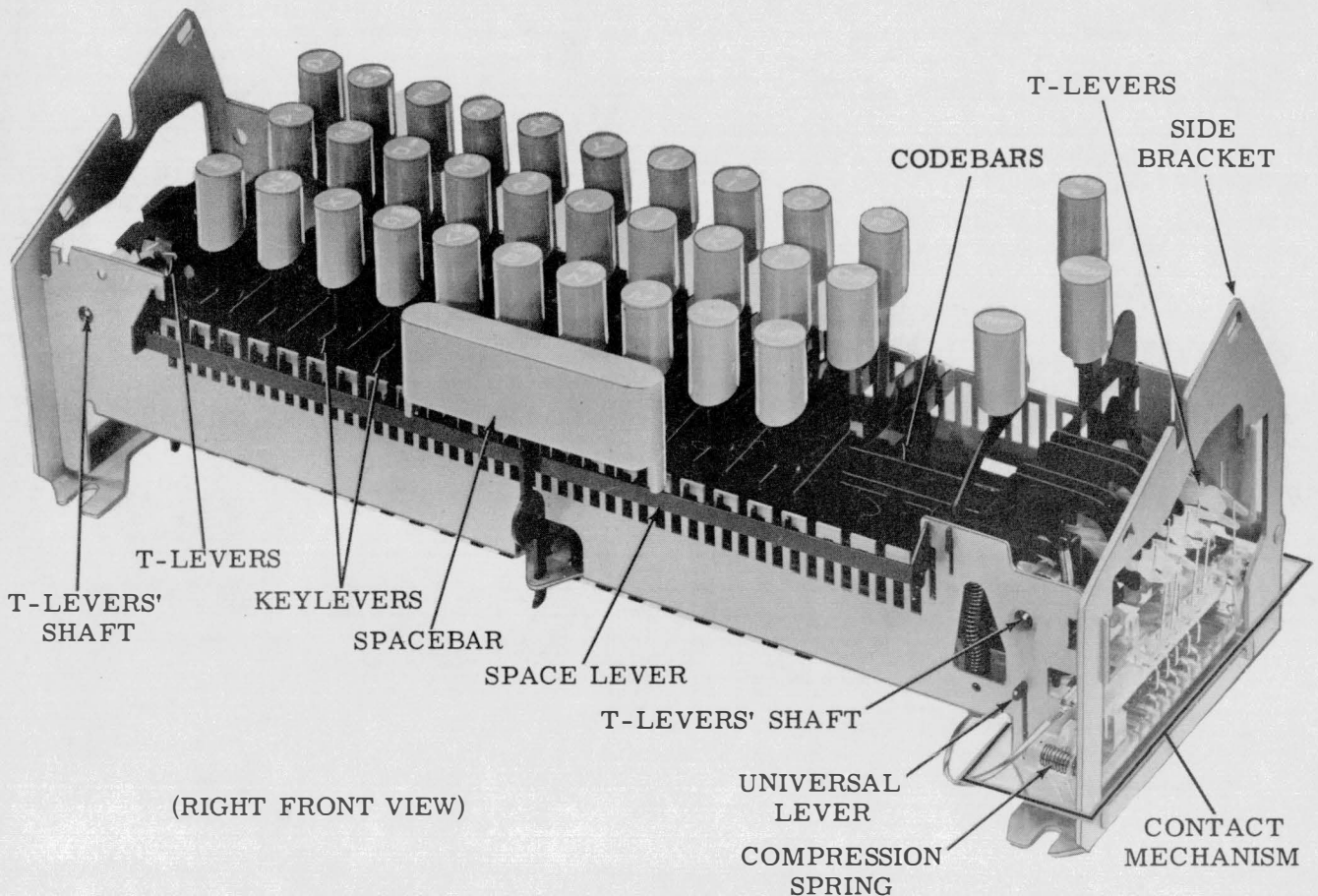

Figure 2 - Keyboard (Cover Removed)

two TP180055 space keylevers. Disengage space keylevers from guide slots and remove them from frame.

Note: Note position of compression springs on keylever's lower stems so that they can be properly replaced during reassembly.

(3) Codebar may be removed after all keylevers are removed. Disengage bars from T-levers and lift out of keyboard frame.

(4) To remove keyboard contact mechanism, remove right side bracket by snapping it off frame. Remove contact mechanism.

Note: Note position of TP180031 compression springs so that they may be properly replaced during reassembly.

(5) To remove the two T-lever shafts, spread frame and lift out. To remove T-levers, remove TP119653 retaining rings and slide levers off their shafts.

(6) To replace miscellaneous parts, reverse procedure used to remove them.

