

BULLETIN 272B

TECHNICAL MANUAL

28 AND 35 ANSWER-BACK UNIT

CONTENTS

**DESCRIPTION AND OPERATION
INSTALLATION
ADJUSTMENTS
LUBRICATION
DISASSEMBLY AND REASSEMBLY**



**TELETYPE[®]
CORPORATION**

5555 TOUHY AVENUE, SKOKIE, ILLINOIS



INTRODUCTION

Bulletin 272B is a technical manual that provides description, installation, and maintenance for the Answer-Back Unit.

The bulletin is made up of a group of appropriate, independent sections. They are separately identified by title and section number. The pages of each section are numbered consecutively, independent of other sections.

The identifying number of a section, a 9-digit number, appears on each page of the section in the upper left corner of left-hand pages and the upper right corner of right-hand pages.

The sections are arranged as shown in the table of contents on the following page. They are in ascending numerical order except where this is contrary to a logical presentation of material.

To locate specific information, proceed as follows:

- Find the involved equipment in the first column of the table of contents.
- Find the type of information in the second column.
- Find the correct 9-digit number opposite these in the third column.
- Turn to Page 1 of the section where its contents can be found.



TABLE OF CONTENTS

<u>Equipment</u>	<u>Contents</u>	<u>Section</u>	<u>Issue</u>
28 and 35 Answer-Back Unit	Description and Operation	574-235-100TC	3
28 and 35 Answer-Back Unit	Installation	574-235-200TC	1
28 and 35 Answer-Back Unit	Adjustments	574-235-700TC	5
28 and 35 Answer-Back Unit	Lubrication	574-235-701TC	4
28 and 35 Answer-Back Unit	Disassembly and Reassembly	574-235-702TC	1

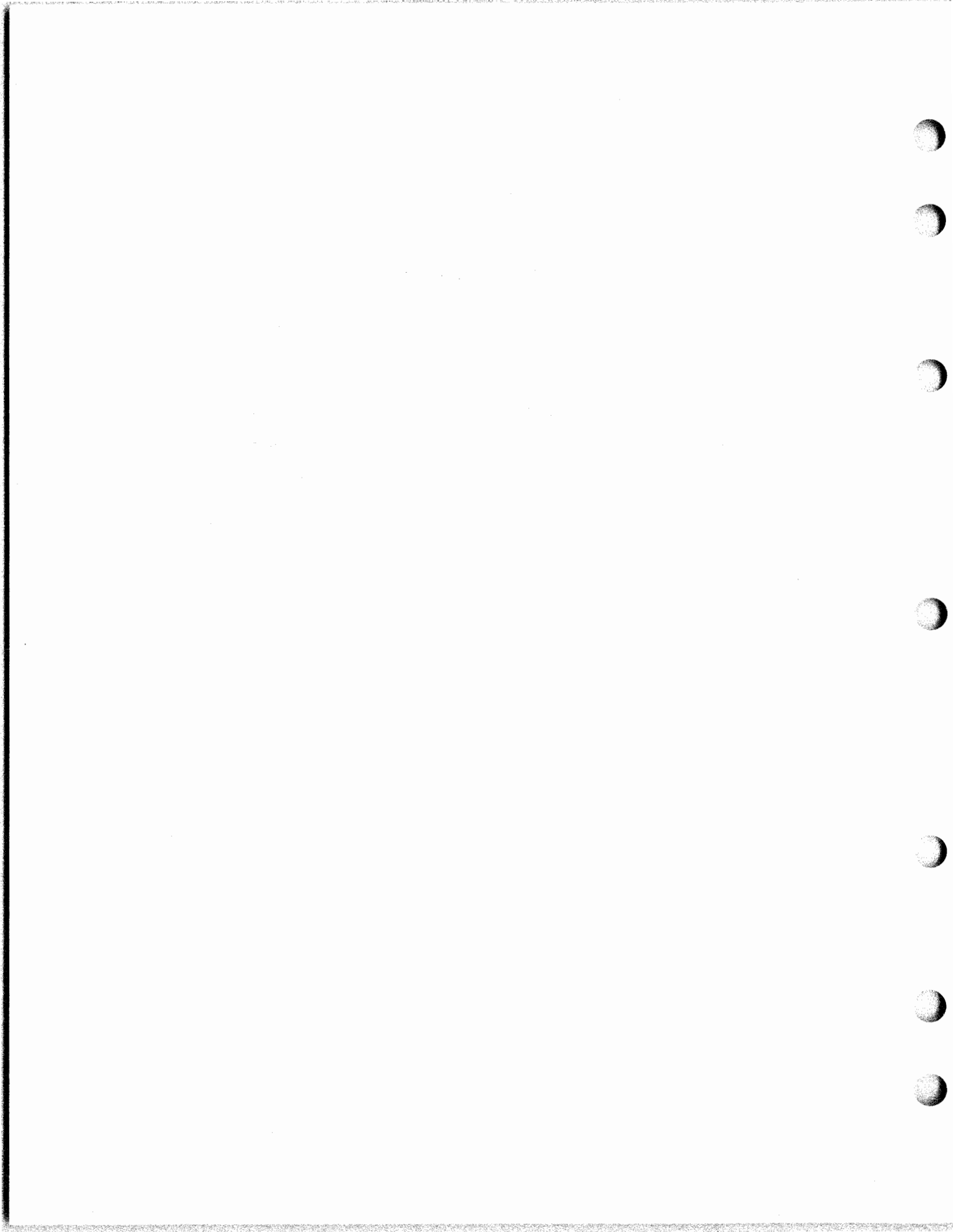

28 AND 35 ANSWER-BACK UNIT

DESCRIPTION AND OPERATION

CONTENTS	PAGE
1. DESCRIPTION	1
COVER	1
BASE	1
ANSWER-BACK MECHANISM	3
MOTOR	3
GENERAL OPERATION	3
2. PRINCIPLES OF OPERATION	4
TRIP MAGNET	4
MAIN SHAFT	5
SPRING CLUTCH	5
FEED MECHANISM	6
CONTACT BLOCK	7
DISTRIBUTOR	7
3. TECHNICAL DATA	7
A. Dimensions and Weight	7
B. Transmission Codes	8
C. Speeds	8
D. Electrical Requirements	8

1. DESCRIPTION

1.01 This section is reissued to add coverage of the 5- and 8-level answer-back unit. Since this reissue is of a general nature, marginal arrows have been omitted.

1.02 The answer-back unit is an electro-mechanical device designed to transmit a predetermined message of not more than 21 characters. The desired message is precoded on the answer-back drum and is transmitted upon receipt of a request signal. The operational speed of the unit may be fixed at 60, 66, 75, or 100 words per minute by installing the proper gear set.

1.03 It may be mounted, with or without a cover, on any flat surface or on a cabinet, rack, or shelf (Figures 1 and 2). Although it is ordinarily used in conjunction with other teletypewriter equipment, it is mechanically independent of any other equipment. Only electrical connections for power and control cir-

cuits are required. In addition, the answer-back mechanism (Figures 3 and 4) may be mounted in a 35 Automatic Send-Receive (ASR), Keyboard Send-Receive (KSR), or Receive-Only (RO) Teletypewriter Set.

1.04 Variations of the answer-back unit are available for distributing either a 5-level, 7.42, or 7.5 unit code or an 8-level, 11.0 unit code. The 5-level answer-back unit has provisions in the code drum, contact wires, and internal wiring for adapting the answer-back mechanism to an 8-level code. Conversion can be accomplished by changing the distributor disc and making the proper wiring connections.

1.05 Mounting facilities, relay pull-up contacts, and internal wiring are included with the answer-back mechanism for field installation of a nonrepeat relay. The nonrepeat relay is utilized in cases where the duration of the trip pulse is longer than the answer-back cycle. The nonrepeat relay de-energizes the trip magnet at the instant the motor hold and relay pull-up contacts are closed.

1.06 The answer-back unit consists of the cover, base, answer-back mechanism motor, terminal block, fuse, fuse-holder, and capacitor.

COVER

1.07 The cover is sprayed on the inner surface with vibration damping material. In addition, pads are attached to the inner surface for absorbing noise from the operating mechanism. The left end of the cover is louvered to admit air for reducing the operating temperature of the unit.

BASE

1.08 The base provides mounting facilities for the terminal block, fuse, fuse-holder, capacitor, motor, answer-back mechanism, and cover. A pad is attached to the underside of

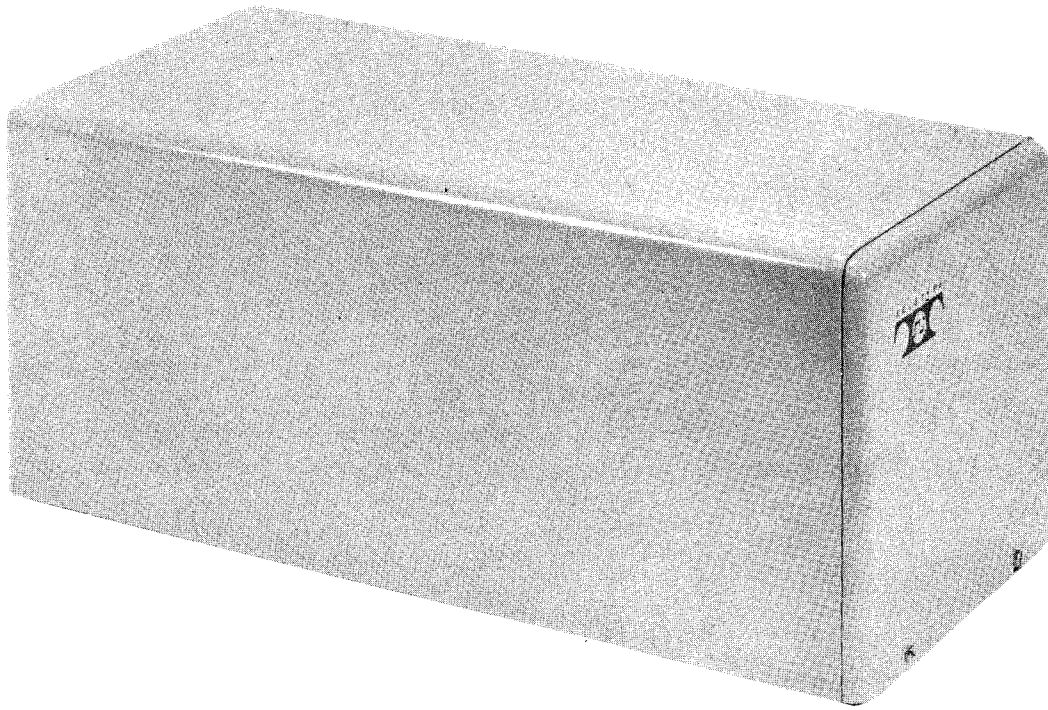

Figure 1 - Answer-Back Unit (With Cover)

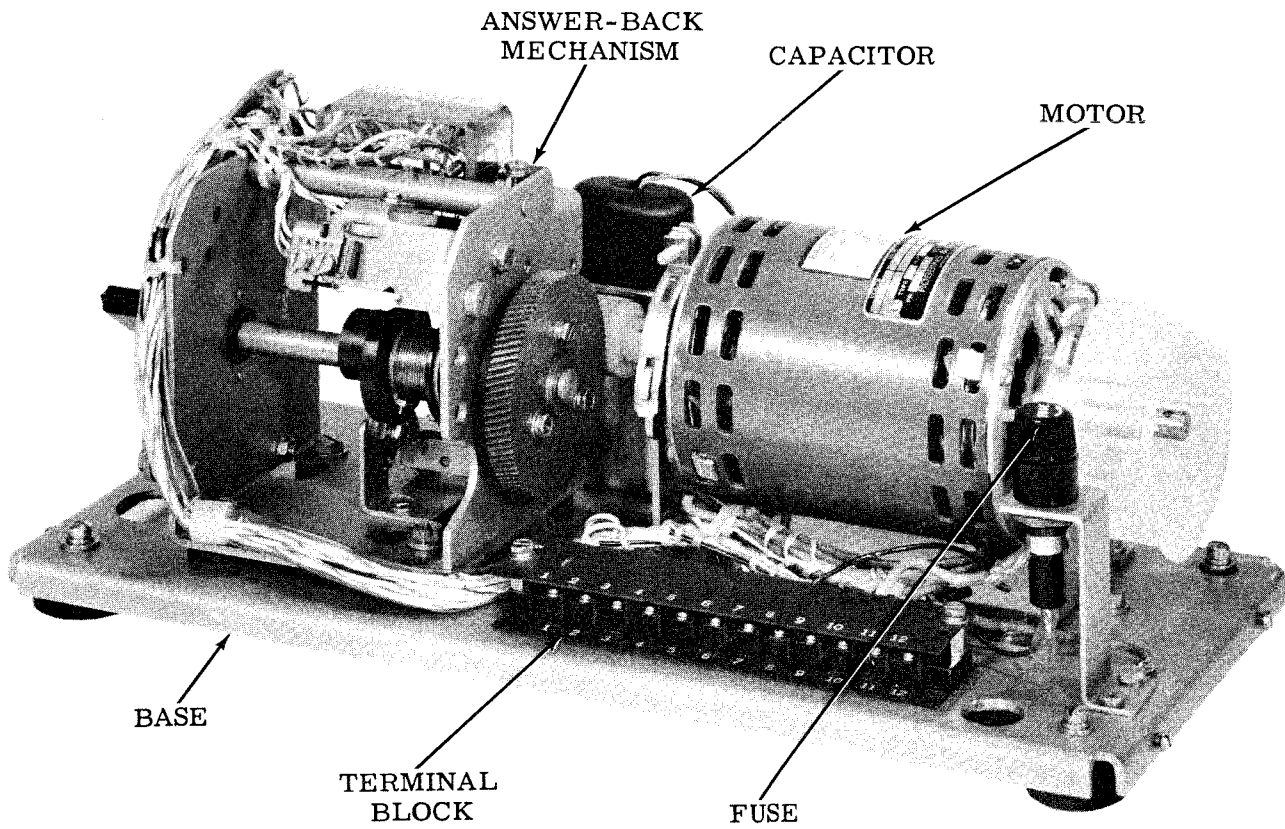

Figure 2 - Answer-Back Unit (Without Cover)

the base to reduce vibration. Four rubber feet support the base.

1.09 The internal wiring harness is attached to the terminal block for external signal, control, and power connections. The block has 12 terminals.

ANSWER-BACK MECHANISM

1.10 The answer-back mechanism may be mounted in the answer-back unit, or a 35 ASR, KSR, or RO Teletypewriter Set. The basic answer-back mechanism shown in Figures 3 and 4, consists of the following parts or subassemblies: trip magnet, code drum, main shaft, feed assembly, contact block, and distributor. The subassemblies are interconnected mechanically and/or electrically to perform all functions incidental to automatic message transmission. In addition, a double set of electrical contacts is provided for motor hold and relay pull-up operations. The motor hold contacts are required for applications where intermittent operation of the motor is both possible and desirable. The relay pull-up contacts apply to the application discussed in Paragraph 1.05.

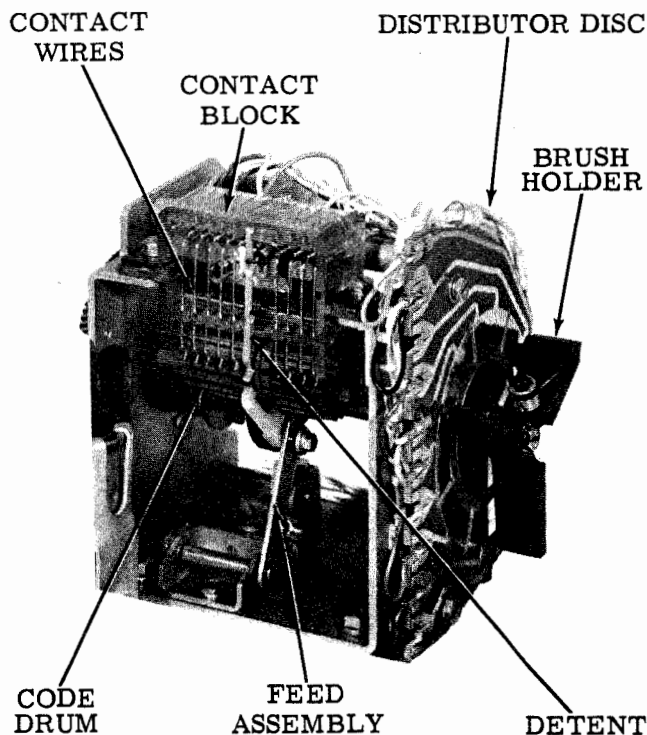

Figure 3 - Answer-Back Mechanism (Rear View)

MOTOR

1.11 A synchronous motor, rated at 1/100 hp and 1800 rpm for 115 ± 10 per cent volts ac operation, is used to drive the answer-back mechanism. The motor is equipped with two windings, a run winding and a capacitor winding for permanent split-phase capacitor operation. The capacitor is encased in metal and has a paper and oil dielectric. A time delay fuse is provided to open the power circuit if the motor is stalled.

GENERAL OPERATION

1.12 Briefly, the parts or subassemblies are interconnected to perform the following functions. An incoming pulse energizes the trip magnet whose armature is deflected to free the code drum, permit the clutch to engage the main shaft, and close a set of contacts. With the main shaft in rotation, the code drum is advanced to the first character position by the feed assembly. The individual contact wires for each code level are automatically set by the precoded character on the answer-back drum. Selected contact wires (marking) touch the common terminal on the contact block for subsequent translation into serial code. Signal power from the terminal block is applied to

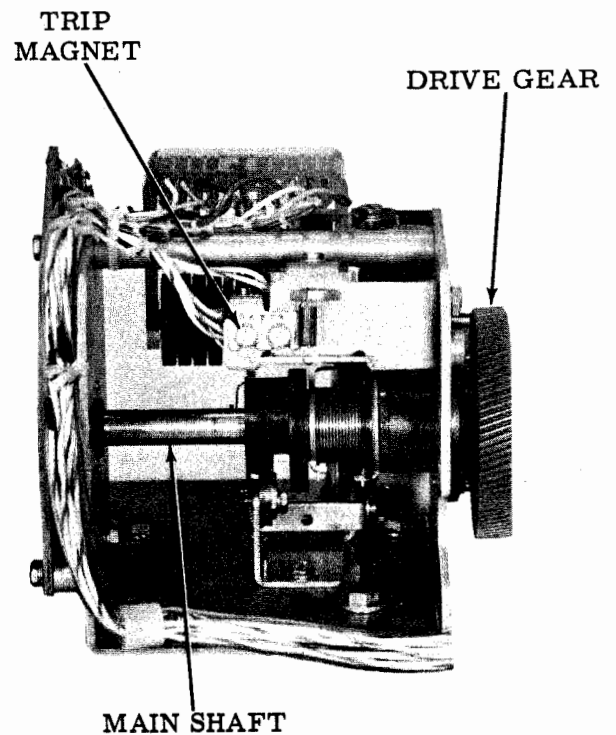

Figure 4 - Answer-Back Mechanism (Front View)

each code level on the contact block through the solid ring on the distributor disc. Each contact wire is sensed as the outer brush on the distributor sweeps its respective distributor segment. All operations necessary for one character transmission, are performed during a single rotation of the main shaft.

1.13 Viewing the code drum with the greater number of radial code tines to the left, there are six numbered (code) levels, feed ratchet, stop control cam, suppression level, and three numbered (code) levels.

1.14 The code drum is designed to function with systems employing 5- or 8-level signal codes. It has 21 rows of code tines and may be coded for one, two, or three cycle operation with message lengths not exceeding 21, 10, and 7 characters, respectively. For applications where the first character is suppressed, the message length is necessarily reduced by one character. The text of the message is further reduced by the number of functions which are peculiar to each system application.

1.15 The contact block, secured to the top rear of the main mounting bracket, contains nine contact wires with provisions for individual cable connections. The common terminal for selected contact wires is located approximately midway between the top and bottom of the contact wires. The detent for limiting the code drum advance to single steps is attached to the contact block.

1.16 The distributor includes a printed circuit with two conducting rings, and a brush holder with two brushes. One conducting ring is solid for applying current. The other ring is segmented with a conducting lead from each segment. The brush holder is fastened to the main shaft. It contains two carbon brushes which are held in place and connected to each other by a spring. One brush rides the solid ring and the other rides the segmented ring.

2. PRINCIPLES OF OPERATION

2.01 The answer-back unit is a self-contained electromechanical device, used for the transmission of a precoded message. The answer-back cycle is actuated when the unit is pulsed by an external request signal.

2.02 Electrical cabling which provides all wiring paths for the power, control, and signal lines is attached to the terminal block on the unit. Mechanical motion for the answer-back mechanism is transmitted through a set of speed change gears. The transmitting speed is determined by the speed change gears. Gear sets are available for operating the answer-back unit at 60, 66, 75, or 100 words per minute. When the motor is running, the answer-back mechanism is held in an idle condition by the disengaged spring clutch on the main shaft.

2.03 The base, fuse, capacitor, and cover are passive components. However, the answer-back mechanism is the principle electromechanical component and is discussed in greater detail in the following paragraphs.

2.04 The answer-back mechanism consists of a trip magnet, main shaft, feed assembly, code drum, contact block, and distributor. An incoming pulse energizes the trip magnet whose armature is deflected to free the code drum, permit the clutch to engage the main shaft, and close a set of contacts. With the main shaft in rotation, the code drum is advanced to the first character position by the feed assembly. The individual contact wires for each code level are automatically set by the precoded character on the code drum. Selected contact wires (marking) touch the common terminal on the contact block for subsequent translation into serial code. Signal power from the terminal block is applied to each code level on the contact block through the solid ring on the distributor disc. Each contact wire is sensed as the outer brush on the distributor sweeps its respective distributor segment. All operations necessary for one character transmission are performed during a single rotation of the main shaft.

TRIP MAGNET

2.05 The trip magnet is attached to the main mounting bracket of the answer-back mechanism as shown in Figure 5. The trip magnet consists of a yoke, magnet core, armature with spring, and electrical contact pile-up. The armature is held away from the magnet core by a spring connecting the rear edge of the armature to the yoke.

2.06 When an incoming pulse energizes the magnet, the attracted armature allows three simultaneous actions to take place. The

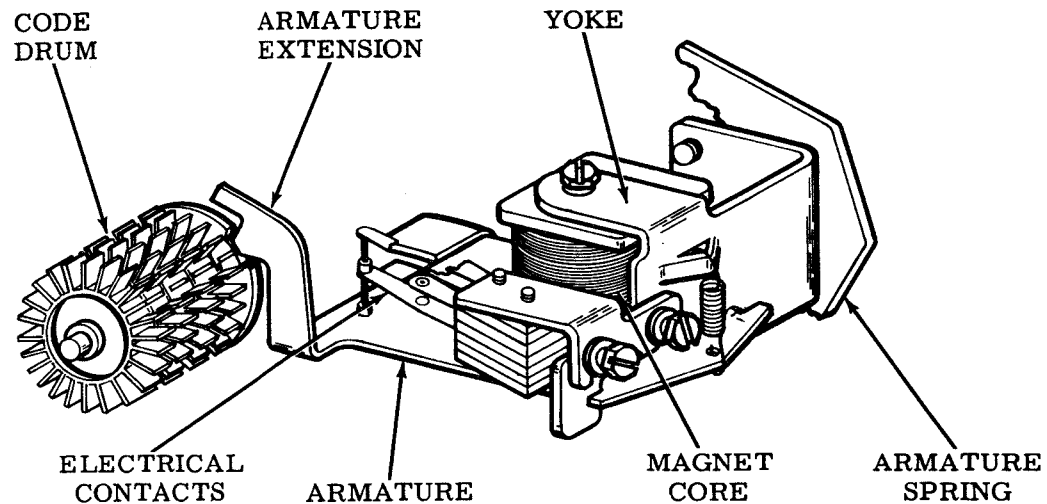

Figure 5 - Trip Magnet

armature extension is extracted from the code drum stop cam; the front edge of the armature permits the clutch release and shaft stop levers to engage the clutch; and the top face of the armature closes a set of electrical contacts. After the incoming pulse has diminished, the armature is physically supported by either mechanical elements on the main shaft or the stop cam on the code drum.

2.07 If the energizing pulse terminates before the code drum is advanced, the released clutch lever supports the armature. The feed takes place within 35 degrees rotation of the main shaft. Then the high part of the code drum stop cam supports the armature extension. When the last character to be distributed appears on the code drum, the motor hold cam, mounted on the main shaft, supports the bottom face of the armature. After distribution of the last character, the motor hold cam allows the armature to fall; the armature extension drops into the opening of the code drum stop cam. As the main shaft continues to rotate, the clutch release lever engages the front edge of the armature, releasing the clutch. Approximately 30 degrees later, the shaft stop lever is engaged to stop the main shaft in a predetermined position.

MAIN SHAFT

2.08 The main shaft delivers rotational motion for advancing the code drum by means of the feed assembly. It also provides rotational motion for distributing the parallel

coded inputs from the contact block. The major elements on the main shaft are the drive gear, spring clutch, and motor hold and feed cam. The distributor brush holder is fastened to the opposite end of the main shaft. The drive end of the main shaft is shown in Figure 6.

SPRING CLUTCH

2.09 The main shaft is separated from the drive gear and clutch sleeve assembly by the spring clutch. See Figure 7. If the trip magnet armature is in the up or run position, the spring clutch engages the rotating clutch sleeve with the main shaft drum. When the armature falls into the stop position, the clutch release lever is engaged first, releasing the clutch, and approximately 30 degrees later, the shaft stop lever is engaged to stop the main shaft in a predetermined position.

2.10 The spring clutch consists of a clutch sleeve, clutch release lever and clutch stop lever bearing, retractile spring, shaft stop lever, and shaft drum. One end of the retractile spring is keyed to the shaft stop lever and the other end is keyed to the clutch release lever. The shaft stop lever is secured to the shaft drum which is keyed to the main shaft. The clutch release lever turns freely on the clutch sleeve by means of the clutch release lever bearing. The gear and clutch sleeve assembly, bearing on the main shaft, extends to a plane midway under the retractile spring. The shaft drum, keyed to the main shaft, extends from the clutch sleeve to the shaft stop lever.

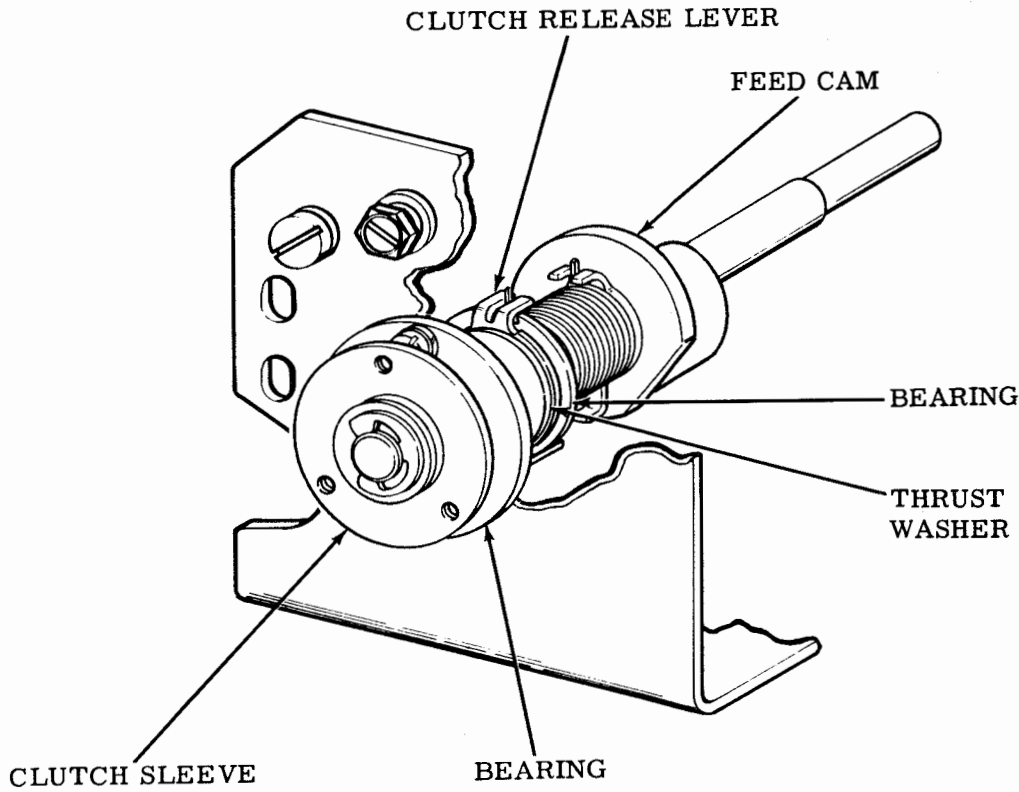

Figure 6 - Main Shaft

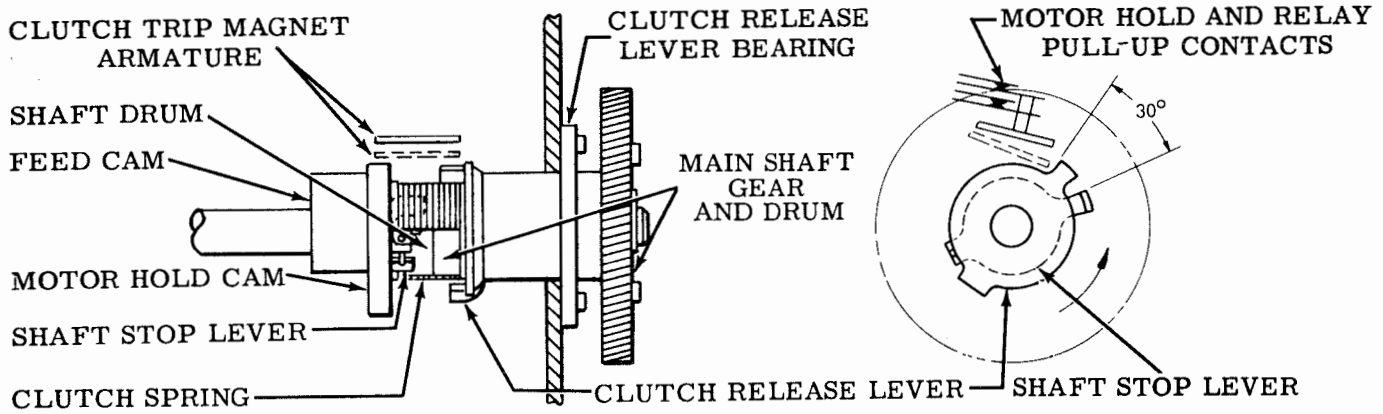

Figure 7 - Spring Clutch

2.11 The retractile spring is mounted over the clutch sleeve and shaft drum with a slight interference fit. When unstressed, the tangs or ends of the spring are approximately 30 degrees apart. As the tangs are forced into alignment, the inside diameter of the spring increases, thereby disengaging the inside surface of the spring from the outside surfaces of the clutch sleeve and shaft drum.

FEED MECHANISM

2.12 The feed mechanism is attached to the base of the main mounting bracket and consists of a feed lever bracket, feed bail, and feed pawl. The mechanism is shown in Figure 8.

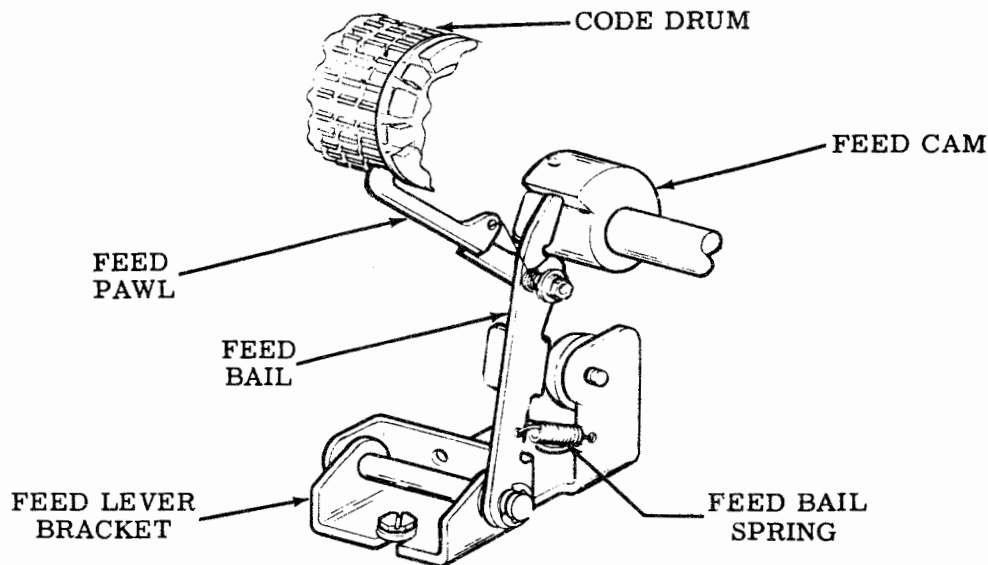

Figure 8 - Feed Mechanism

2.13 At 15 degrees rotation of the main shaft, the feed bail is pulled off the high part of the feed cam by the feed bail spring. Simultaneously, the feed pawl advances the code drum. The code drum is then detented so that the contact wires on the contact block are sensing the first character to be distributed. The feed cycle occurs within an interval of 20 degrees rotation of the main shaft.

CONTACT BLOCK

2.14 The contact block contains nine contact wires with provisions for cable connections, a detent spring, and a common terminal. The code drum is inserted in the slots formed by the contact block extensions. See Figure 3. The common terminal for selected contact wires is located approximately midway between the top and bottom of the contact wires. The contact wires are aligned to follow their respective tines on the code drum.

2.15 Wherever a plastic tine is removed from the code drum, the respective contact wire falls into its slot to meet the common terminal. All effective contact wires representing one coded character, are simultaneously preset at each step of the code drum. Signal current is routed from the terminal block and is sequentially applied to each contact wire through the distributor. The output from the common terminal on the contact block is transmitted over the line as a serial start-stop code.

DISTRIBUTOR

2.16 The distributor consists of a distributor disc and distributor brush holder with brushes. Each effective contact wire on the contact block is connected to its respective segmented level on the distributor disc. The distributor is shown in Figure 3. Signal current is transferred from the inner solid ring to the outer segmented ring through the distributor brushes. The electrical transfer occurs through the torsion spring connecting the set of brushes. The spring serves a double purpose, ie, applies mechanical pressure and provides electrical continuity between the brushes.

3. TECHNICAL DATA

A. Dimensions and Weight

3.01 The external dimensions and weight of the unit are:

- (1) Height - 6 inches
- (2) Width - 6 inches
- (3) Length - 13-1/4 inches
- (4) Weight - 13 pounds

SECTION 574-235-100

B. Transmission Codes

3.02 Data is transmitted by the 5-level answer-back unit in the 7.42 or 7.5 unit code. One start bit, five intelligence bits, and a stop pulse 1.42 or 1.5 bits in length make up the code. The 8-level answer-back unit transmits data in the 11.0 unit code. One start bit, eight intelligence bits, and a stop pulse 2 bits in length make up the code. The 5-level unit may be converted to 8-level operation as previously discussed in Paragraph 1.04.

C. Speeds

3.03 The speed of the answer-back unit is determined by the speed change gears. Gear sets are available in both 5- and 8-level operation for the following speeds shown.

LEVEL	UNIT CODE	SPEED WORDS PER MINUTE	GEAR SET
5	7.42	60	TP305047 TP305048
		100	
5	7.5	60	TP194808 TP199096 TP194809 TP194815
		66	
		75	
		100	
8	11.0	100	TP194815

D. Electrical Requirements

3.04 Power input to the unit is 110 volts ac \pm 10 per cent or 48 volts dc \pm 10 per cent. The power input circuit is protected by a (slow-blow) 0.80 ampere fuse. Maximum current draw is 100 amperes with either power source. All power, control, and signal lines terminate in a 12-point screw-type terminal block.

28 AND 35 ANSWER-BACK UNIT

INSTALLATION

CONTENTS	PAGE
1. GENERAL	1
UNPACKING	1
2. COMPONENTS	1
3. INSTALLATION	1
SPEED CHANGE GEARS	1
POWER AND CONTROL CIRCUITS	2
4. CODING ANSWER-BACK DRUM	2
CODING EXAMPLES	5

1. GENERAL

1.01 This section provides instructions for unpacking, installing, and connecting the answer-back unit.

1.02 The answer-back unit is mechanically independent of any other equipment. Only electrical connections for power and control circuits are required.

1.03 References made to left or right, up or down, and front or rear apply to the answer-back unit as viewed from the side with the answer-back mechanism to the left and the motor to the right.

UNPACKING

1.04 Open shipping carton carefully. Be sure the carton is resting top side up. Clip any strapping and carefully cut or slit paper tape or fiber carton seals to avoid damage to finished surfaces of the equipment.

2. COMPONENTS

2.01 The answer-back unit consists of the cover, base, motor, answer-back mechanism, terminal block, fuse, fuse-holder, and capacitor.

2.02 The answer-back unit is shipped completely assembled with the exception of the speed change gears which are ordered separately for the desired operating speed. Gear sets are available for both 5- and 8-level operation as shown below:

LEVEL	UNIT CODE	SPEED WORDS PER MINUTE	GEAR SET
5	7.42	60	TP305047 TP305048
		100	
5	7.5	60	TP194808 TP199096 TP194809 TP194815
		66	
		75	
		100	
8	11.0	100	TP194815

2.03 The answer-back unit may be placed on any hard, flat horizontal surface, or on a cabinet, rack or shelf. A soft surface or pad should not be used since the free flow of exhaust air will be restricted. The louvered end of the unit should be placed at least one inch from the wall or any other obstructing area which might restrict the air intake.

2.04 The answer-back mechanism is the principle electromechanical component, and may be mounted in the answer-back unit, or 35 Automatic Send-Receive (ASR), Keyboard Send-Receive (KSR), or Receive-Only (RO) Teletypewriter Set.

2.05 The answer-back mechanism, when mounted in 35-type equipment, is normally factory assembled and installed as a part of the base.

3. INSTALLATION

SPEED CHANGE GEARS

3.01 Loosen the cover fastening screws and remove the cover. Remove the screw from the motor shaft and install the pinion.

Remove the three gear mounting screws from the clutch sleeve and install the drive gear. Apply a thin coat of grease on the gears.

3.02 Make the gear mesh adjustment as given in the appropriate section which covers the answer-back unit and mechanism adjustments.

POWER AND CONTROL CIRCUITS

3.03 All electrical connections are made to the terminal block on the base plate. Connections to this block are made with spade-type terminal lugs inserted under the screws on the block. Consult the following wiring diagrams for the 5- and 8-level answer-back units:

- (a) 5-level unit -- WD4728
- (b) 8-level unit -- WD6378

4. CODING ANSWER-BACK DRUM

4.01 Figures 1 and 2 illustrate the coding of the answer-back drum. To remove the drum, proceed as follows: Lift the answer-back brace, by means of its extension, to deflect all contact wires and the detent away from the code drum. Hold the feed pawl away, and slip the code drum out. Do not overextend the feed pawl spring.

4.02 The code drum, prior to coding, is identical in either 5- or 8-level operation. As can be seen in Figure 1, three levels are not used when coding the drum for 5-level operation. The tines in these three levels may be left intact, since no contact wire springs sense these positions. When coding the drum for 8-level operation, all levels on the drum are used. See Figure 2.

4.03 The drum is coded in a counterclockwise direction (viewed from the numbered end), beginning with the start (ST) row 1. Code the drum by breaking and removing the tines as designated in Figure 1 or 2. Either of the two following methods may be used for breaking off tines:

- (a) Method 1: Use a screwdriver to remove each tine. Place the end of the screwdriver blade at the base of the tine to be removed. While applying pressure against the base of the adjacent tine, press the side of the blade against the top of the

tine to be removed until it breaks. If both tines adjacent to the tine to be removed have been broken off, apply the end of the screwdriver to the stub of either one in breaking off the unwanted tine. This method of removing a tine is indicated in the illustration showing the tine rows in Figures 1 and 2. In the illustration, pressure is being applied to the base of row 20 tine and against the top of an adjacent tine in row 19 to break it off.

- (b) Method 2: Use a TP161686 tine tool or a pair of long-nosed pliers to remove each unwanted tine. Place the unwanted tine into slot of the tine tool, or grasp the unwanted tine firmly with the long-nosed pliers, and then, with the tool or the pliers held stationary, rotate the drum back and forth until the unwanted tine breaks off near its base. Use care not to damage adjacent tines.

4.04 The procedures described in the following paragraphs may be altered to suit a particular system or application. Where one character delay is required after the answer-back is tripped off and before the coded message begins, the character suppression tine should be removed in the (ST) start row of the code drum to provide the delay. If the first character suppression is not used, message coding starts on the rows shown coded with character suppression in Figures 1 and 2.

4.05 Normally, a coded message should contain CR (carriage return) and LF (line feed) near the beginning and again near the end of the message. This assures that the transmitted message will appear at the beginning of a line on the receiving Teletypewriter Set, and that overprinting of the message will not occur. In 5-level operation, the coded message should also contain the "letters" code combination at the beginning of a message to place each Teletypewriter Set in the unshift position.

4.06 If the suppression tine is not removed in the ST row, the coded message may contain 21 characters for one-cycle operation, 10 characters for two-cycle operation, and 7 characters for three-cycle operation. Unused message coding rows should be coded using the suppression level.

4.07 If the suppression tine is removed, in the ST row, the message length is reduced by one character. The text of the message is further reduced by the number of func-

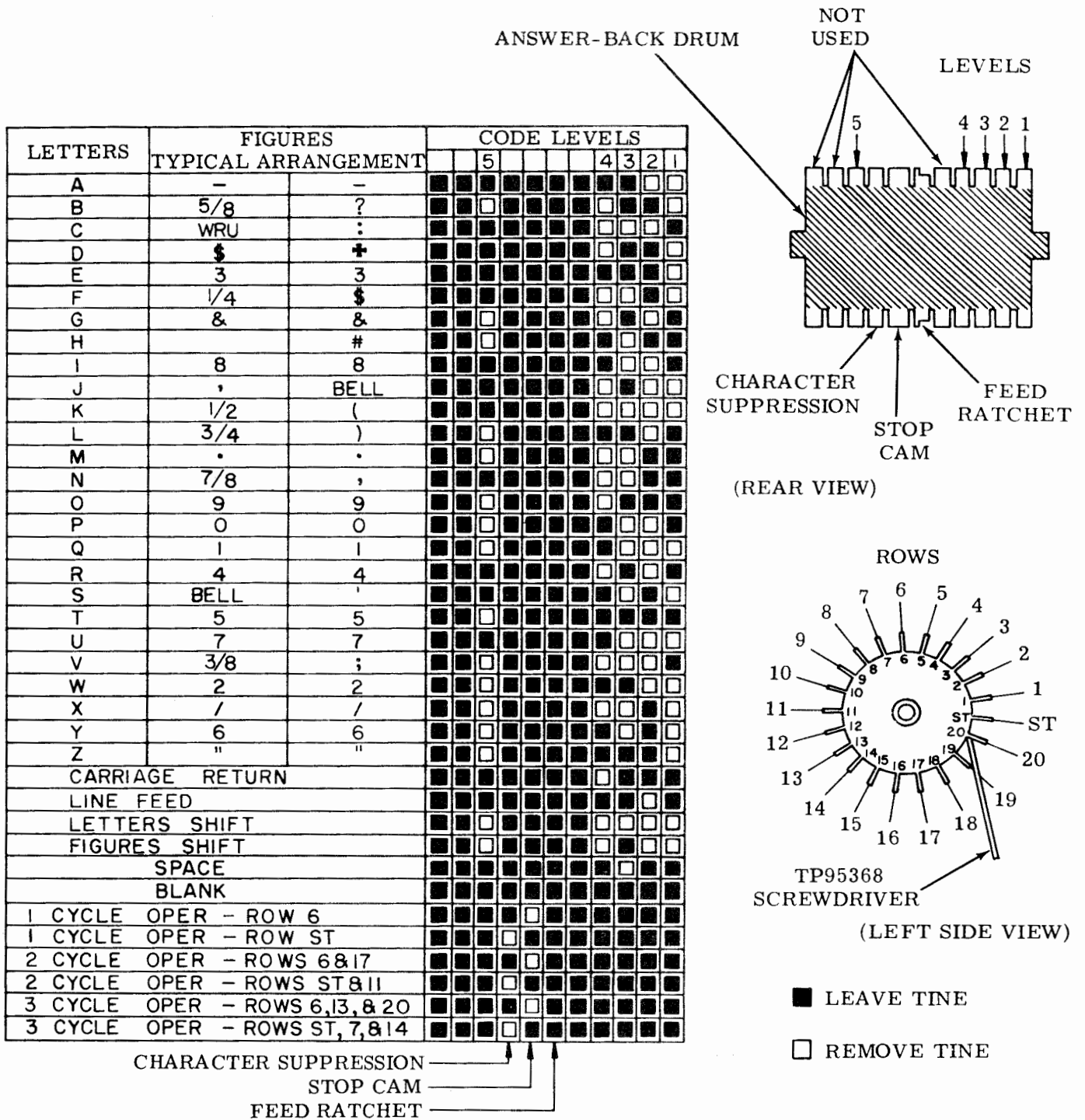
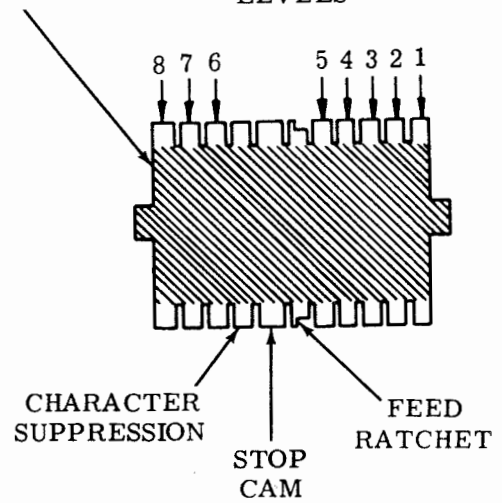

Figure 1 - Coding of Answer-Back Drum - 5-Level Teletypewriter Code

ANSWER-BACK DRUM

LEVELS

	CODE LEVELS									CODE LEVELS																				
	8	7	6			5	4	3		2	1	8	7	6			5	4	3	2	1									
NULL	■	■	■	■	■	■	■	■	■	2	■	■	■	■	■	■	■	■	■	■										
SOM	□	■	■	■	■	■	■	■	■	3	■	■	■	■	■	■	■	■	■	■										
EOA	□	■	■	■	■	■	■	■	■	4	■	■	■	■	■	■	■	■	■	■										
EOM	■	■	■	■	■	■	■	■	■	5	■	■	■	■	■	■	■	■	■	■										
EOT	□	■	■	■	■	■	■	■	■	6	■	■	■	■	■	■	■	■	■	■										
WRU	■	■	■	■	■	■	■	■	■	7	■	■	■	■	■	■	■	■	■	■										
RU	■	■	■	■	■	■	■	■	■	8	■	■	■	■	■	■	■	■	■	■										
BELL	□	■	■	■	■	■	■	■	■	9	■	■	■	■	■	■	■	■	■	■										
FE ₀	□	■	■	■	■	■	■	■	■	:	■	■	■	■	■	■	■	■	■	■										
HT	■	■	■	■	■	■	■	■	■	;	■	■	■	■	■	■	■	■	■	■										
LF	■	■	■	■	■	■	■	■	■	<	■	■	■	■	■	■	■	■	■	■										
VT	□	■	■	■	■	■	■	■	■	=	■	■	■	■	■	■	■	■	■	■										
FF	■	■	■	■	■	■	■	■	■	>	■	■	■	■	■	■	■	■	■	■										
CR	□	■	■	■	■	■	■	■	■	?	■	■	■	■	■	■	■	■	■	■										
SO	□	■	■	■	■	■	■	■	■	@	■	■	■	■	■	■	■	■	■	■										
SI	■	■	■	■	■	■	■	■	■	A	■	■	■	■	■	■	■	■	■	■										
DC ₀	□	■	■	■	■	■	■	■	■	B	■	■	■	■	■	■	■	■	■	■										
XON	■	■	■	■	■	■	■	■	■	C	■	■	■	■	■	■	■	■	■	■										
RION	■	■	■	■	■	■	■	■	■	D	■	■	■	■	■	■	■	■	■	■										
XOFF	□	■	■	■	■	■	■	■	■	E	■	■	■	■	■	■	■	■	■	■										
RIOFF	■	■	■	■	■	■	■	■	■	F	■	■	■	■	■	■	■	■	■	■										
ERROR	□	■	■	■	■	■	■	■	■	G	■	■	■	■	■	■	■	■	■	■										
SYNCH	□	■	■	■	■	■	■	■	■	H	■	■	■	■	■	■	■	■	■	■										
EOB	■	■	■	■	■	■	■	■	■	I	■	■	■	■	■	■	■	■	■	■										
S ₀	■	■	■	■	■	■	■	■	■	J	■	■	■	■	■	■	■	■	■	■										
S ₁	□	■	■	■	■	■	■	■	■	K	■	■	■	■	■	■	■	■	■	■										
S ₂	□	■	■	■	■	■	■	■	■	L	■	■	■	■	■	■	■	■	■	■										
S ₃	■	■	■	■	■	■	■	■	■	M	■	■	■	■	■	■	■	■	■	■										
S ₄	□	■	■	■	■	■	■	■	■	N	■	■	■	■	■	■	■	■	■	■										
S ₅	■	■	■	■	■	■	■	■	■	O	■	■	■	■	■	■	■	■	■	■										
S ₆	■	■	■	■	■	■	■	■	■	P	■	■	■	■	■	■	■	■	■	■										
S ₇	□	■	■	■	■	■	■	■	■	Q	■	■	■	■	■	■	■	■	■	■										
SPACE	□	■	■	■	■	■	■	■	■	R	■	■	■	■	■	■	■	■	■	■										
!	■	■	■	■	■	■	■	■	■	S	■	■	■	■	■	■	■	■	■	■										
!!	□	■	■	■	■	■	■	■	■	T	■	■	■	■	■	■	■	■	■	■										
#	□	■	■	■	■	■	■	■	■	U	■	■	■	■	■	■	■	■	■	■										
\$	■	■	■	■	■	■	■	■	■	V	■	■	■	■	■	■	■	■	■	■										
%	□	■	■	■	■	■	■	■	■	W	■	■	■	■	■	■	■	■	■	■										
&	□	■	■	■	■	■	■	■	■	X	■	■	■	■	■	■	■	■	■	■										
'	■	■	■	■	■	■	■	■	■	Y	■	■	■	■	■	■	■	■	■	■										
(■	■	■	■	■	■	■	■	■	Z	■	■	■	■	■	■	■	■	■	■										
)	□	■	■	■	■	■	■	■	■	[■	■	■	■	■	■	■	■	■	■										
*	□	■	■	■	■	■	■	■	■	\	■	■	■	■	■	■	■	■	■	■										
+	■	■	■	■	■	■	■	■	■]	■	■	■	■	■	■	■	■	■	■										
,	□	■	■	■	■	■	■	■	■	^	■	■	■	■	■	■	■	■	■	■										
-	■	■	■	■	■	■	■	■	■	_	■	■	■	■	■	■	■	■	■	■										
.	■	■	■	■	■	■	■	■	■	ACK	■	■	■	■	■	■	■	■	■	■										
/	□	■	■	■	■	■	■	■	■	ALT MODE	■	■	■	■	■	■	■	■	■	■										
0	■	■	■	■	■	■	■	■	■	ESC	■	■	■	■	■	■	■	■	■	■										
1	□	■	■	■	■	■	■	■	■	RUB OUT	■	■	■	■	■	■	■	■	■	■										
1 CYCLE OPER ROW 6											■	■	■	■	■	■	■	■	■	■	■	■	■	■	■	■	■	■	■	
1 CYCLE OPER ROW ST											■	■	■	■	■	■	■	■	■	■	■	■	■	■	■	■	■	■	■	■
2 CYCLE OPER ROWS 6 & 17											■	■	■	■	■	■	■	■	■	■	■	■	■	■	■	■	■	■	■	■
2 CYCLE OPER ROWS ST & 11											■	■	■	■	■	■	■	■	■	■	■	■	■	■	■	■	■	■	■	■
3 CYCLE OPER ROWS 6, 13, 20											■	■	■	■	■	■	■	■	■	■	■	■	■	■	■	■	■	■	■	■
3 CYCLE OPER ROWS ST, 7, 14											■	■	■	■	■	■	■	■	■	■	■	■	■	■	■	■	■	■	■	■



(REAR VIEW)

Note: Level eight must be coded as shown for even parity operation. Without even parity, the level eight code tine may be removed for all characters.

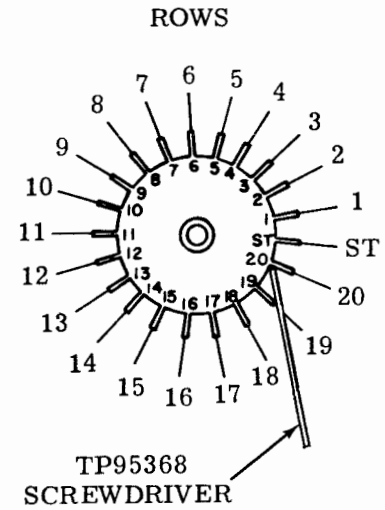

(LEFT SIDE VIEW)

- LEAVE TINE
- REMOVE TINE

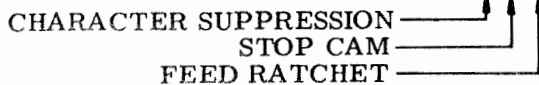

Figure 2 - Coding of Answer-Back Drum - 8-Level ASCII Teletypewriter Code

tions which are peculiar to each system or application. With the suppression tine removed, a station identification message will contain no more than 20 characters, including spaces and nonprinting functions.

4.08 The length of an answer-back sequence can be varied either by removing the characters suppression level tine and/or the stop cam level tine. These two code drum levels, stop cam and character suppression, must always be coded in the same relationship to each other. (See Figures 1 and 2.)

4.09 A one-, two-, or three-cycle operation can be obtained by removing the appropriate tines from the stop cam level. Use two- or three-cycle operation for short messages and one-cycle for longer sequences. With the suppression tine removed, two-cycle operation permits 9 characters to be coded in each half of the drum. Three-cycle operation allows 6 characters to be coded in each third.

Note: Another use which can be made of the character suppression level tines is the elimination of coding errors. If a coding error is made, or for some reason it is necessary to suppress (erase) characters from the code drum, remove the character suppression tine from the rows affected.

CODING EXAMPLES

4.10 In each particular system or application, different methods of coding may be used. In the following two examples, specific coding for particular applications are given:

(a) Example 1: (Switched Network Service Application)

- (1) Stations capable of answering automatically are equipped with multi-character identification (WRU).
- (2) The multicharacter identification answer-back equipped station provides a specific answer back. The station identifier for single cycle operation may not exceed 12 characters, including

spaces and nonprinting functions. The drum should be coded as follows:

SUP-CR-LF-RO and then the 12 character company identification followed by CR-LF-XON-SUP-SUP, where:

CR = Carriage Return
 LF = Line Feed
 RO = Rub Out
 SUP = Suppress
 XON = Transmitter On

(b) Example 2:

(1) SUP-CR-LF-RO
ROBERTS, AMES — CR-LF-XON-
COMPANY CITY, SUP-SUP
 Station Identification
 (Maximum - 12 characters)

If the station identifier is less than 12 characters in length, then the remaining positions must be filled up with the SUP-PRESSION character shown below:

(2) SUP-CR-LF-RO
ERIE, SP BOST — CR-LF-
COMPANY CITY, XON-SUP-
 Station Identification SUP-SUP-
 (Less than maximum SUP-SUP
 number of characters)

It will be noted that for this application, the XON character code combination must be the final significant character, and may be followed by the suppress code only.

4.11 To replace the coded answer-back drum, hold the feed pawl and answer-back brace out of the way. Slide the drum in place, and release the answer-back brace and feed pawl. Rotate the drum against the contact springs and detent lever until the shaft drops over the rear of the contact block on the right and left sides. Lower the drum until the shaft seats into the right and left slots. Rotate the drum against its detent to assure proper seating of the associated parts. Check that the contact springs are located in their proper slots.

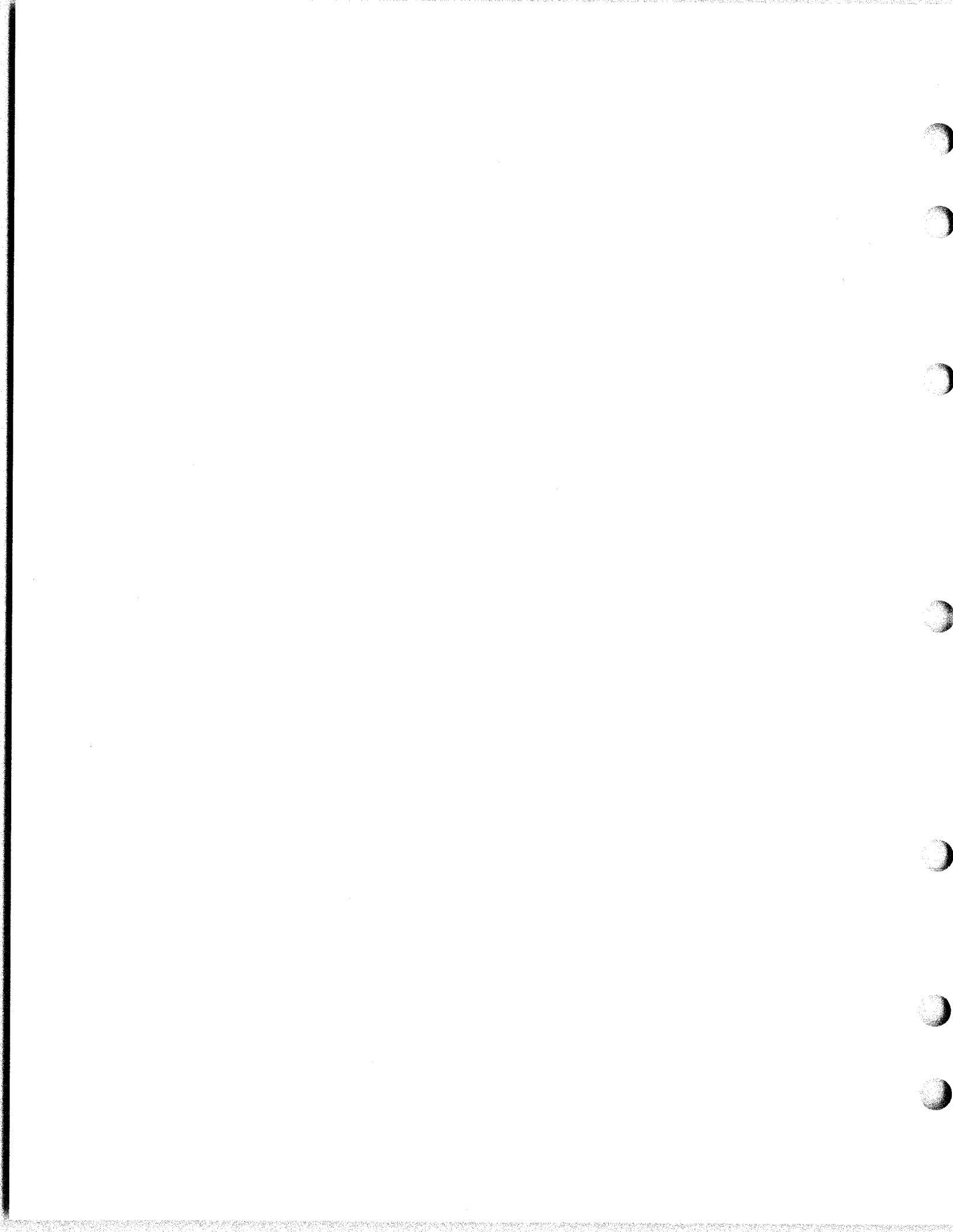

28 AND 35 ANSWER-BACK UNIT

ADJUSTMENTS

CONTENTS	PAGE
1. GENERAL	1
2. BASIC UNITS	2
Trip Mechanism	
Armature extension gap	2
Clutch trip magnet armature spring .	3
Contact block position (final)	3
Contact block position (preliminary) .	2
Feed Mechanism	
Code drum contact wire spring	6
Code drum detent spring	6
Eccentric stop position	5
Feed bail spring	4
Feed pawl	4
Feed pawl spring	5
Relay Brackets and Contacts	
Motor hold and relay pull-up contact bracket	6
Motor hold and relay pull-up contact .	7
Nonrepeat relay	7
Distributor Brushes	
Brush holder spring	8
Distributor brush holder	8
Gear Backlash	
Gear backlash - ASR (transmitter base)	10
Gear backlash - RO, KSR	9
Gear backlash - self-contained unit . .	9

1.02 The adjustments in this section are arranged in a sequence that should be followed if a complete readjustment is undertaken. A complete adjusting procedure should be read before attempting to make the adjustment. After an adjustment is made, be sure to tighten any nuts or screws that may have been loosened, unless otherwise instructed.

1.03 The adjustment illustrations indicate tolerances, positions of moving parts, spring tensions, and the angle at which scales should be applied. The tools required to make adjustments and check spring tensions are not supplied with the equipment, but are listed in the appropriate section under separate cover. Springs which do not meet the requirements, and for which there are no adjusting procedures, should be discarded and replaced by new springs.

1.04 Where adjustment instructions call for removal of components, assemblies, subassemblies, or parts, all adjustments which the removal of these parts might facilitate should be made before the parts are replaced, or as the equipment is reassembled. When a part mounted on shims is removed, the number and location of shims should be noted so that the identical pile-up can be made when the part is replaced.

1.05 All electrical contact points should meet squarely. Contacts with the same diameter should not be out of alignment more than 25 per cent of the contact diameter. Check contacts for pitting and corrosion and clean or burnish them before making the specified adjustment or tolerance measurement. Avoid sharp kinks or bends in the contact springs.

Note: Keep all electrical contacts free of oil and grease.

1. GENERAL

1.01 This section is reissued to add coverage of the 5- and 8-level answer-back unit. Since this revision is of a general nature, marginal arrows have been omitted.

1.06 References made to left or right, up or down, and front or rear apply to the answer-back unit as viewed from the side with

the answer-back mechanism to the left and the motor to the right.

1.07 Unless otherwise specified, where the stop position of the answer-back mechanism is referred to, the lugs of both the clutch release lever and shaft stop lever should be against the armature, with the armature exten-

sion resting in the stop indent of the code drum stop cam.

1.08 Instructions for coding the answer-back drum are not included in this section. Refer to the appropriate section covering installation of the answer-back unit for detailed coding instructions.

2. BASIC UNITS

2.01 Trip Mechanism

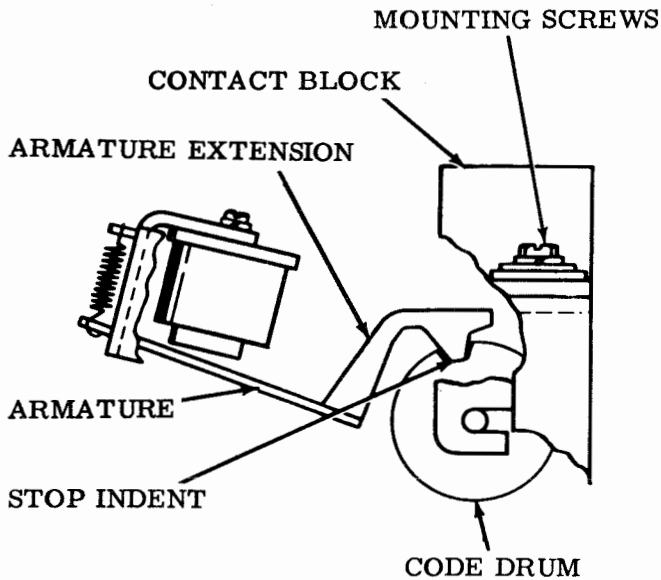

CONTACT BLOCK POSITION (PRELIMINARY)

Requirement

Answer back in stop position, armature extension must drop into stop indent in code drum stop cam.

To Adjust

Step code drum to last character. Rotate main shaft further until the motor hold cam allows armature to drop. Position the contact block until armature extension drops into indent with the contact block mounting screws loosened.

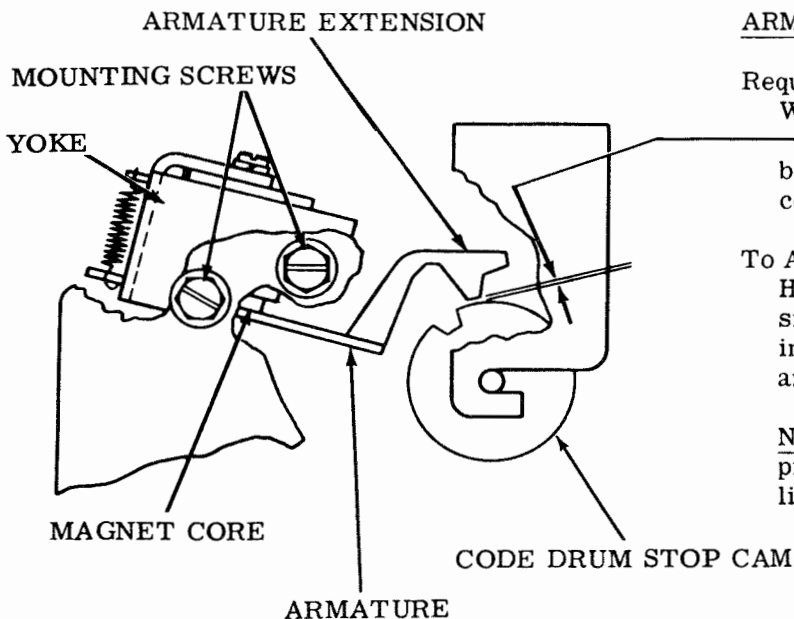

ARMATURE EXTENSION GAP

Requirement

With armature held against magnet core
 Min some---Max 0.015 inch
 between armature extension and high part of code drum stop cam.

To Adjust

Hold armature against magnet core and position magnet yoke assembly with its mounting screws friction tight. Recheck clearance after tightening screws.

Note: When holding armature against core, press between pivot and core to prevent lifting armature.

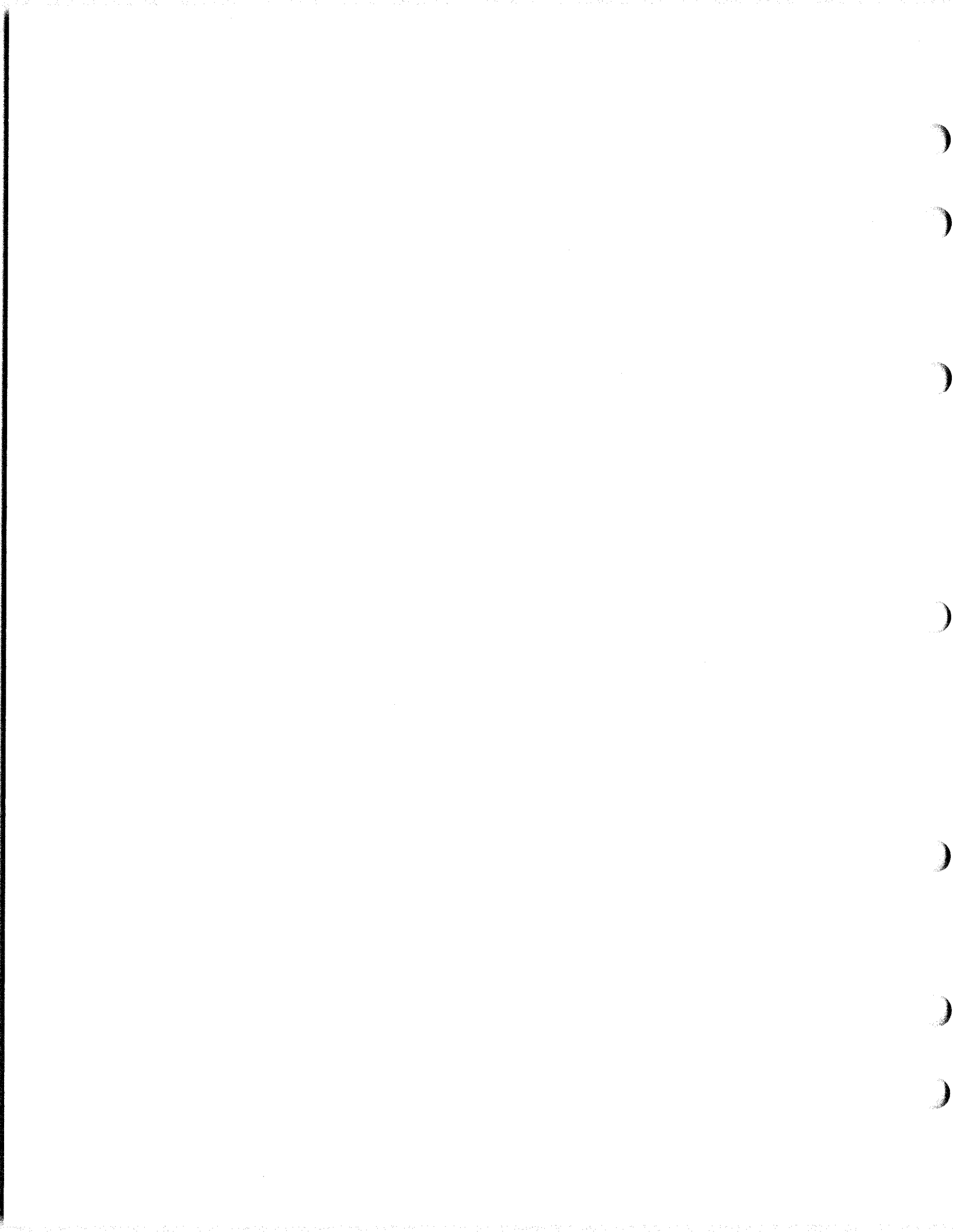

2.03 Feed Mechanism

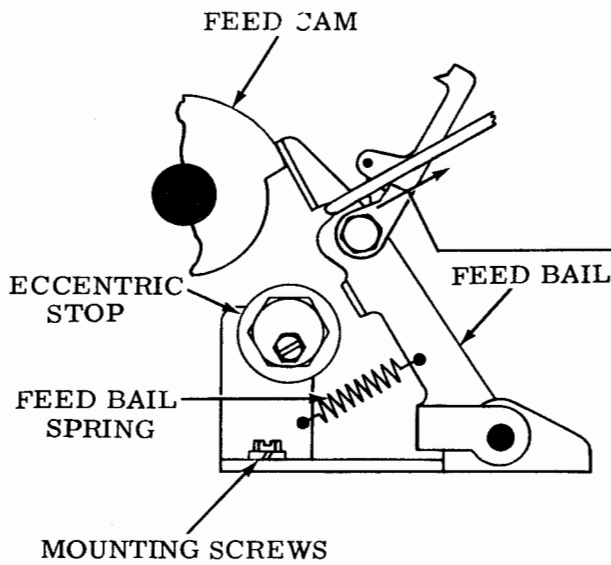

FEED BAIL SPRING

Requirement

With code drum removed and feed bail on high part of its cam to start bail moving.

To Adjust

With bracket mounting screws friction tight, position bracket to increase or decrease tension. Tighten screws.

Note: When new code drum is installed, refine spring tension toward 17 ozs.

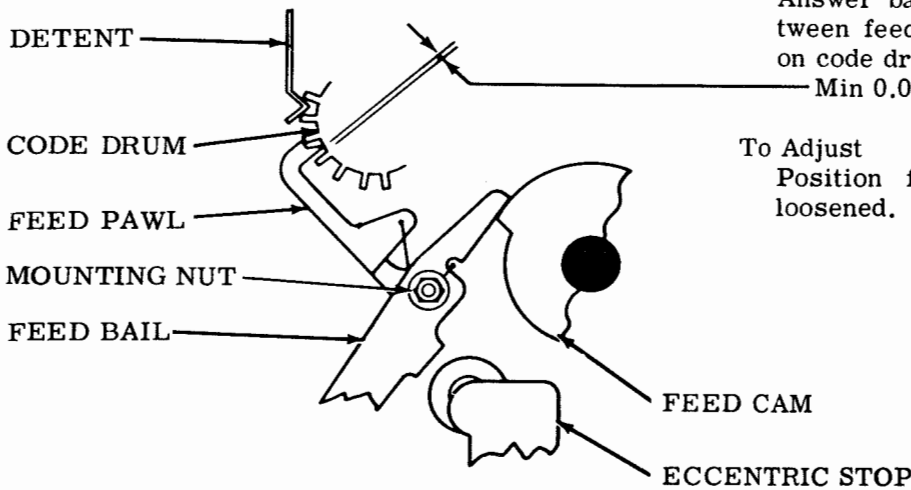

FEED PAWL

Requirement

Answer back in stop position, clearance between feed pawl engaging surface and tooth on code drum.

Min 0.005 inch---Max 0.015 inch

To Adjust

Position feed pawl with its mounting nut loosened. Tighten nut and recheck.

2.04 Feed Mechanism (continued)

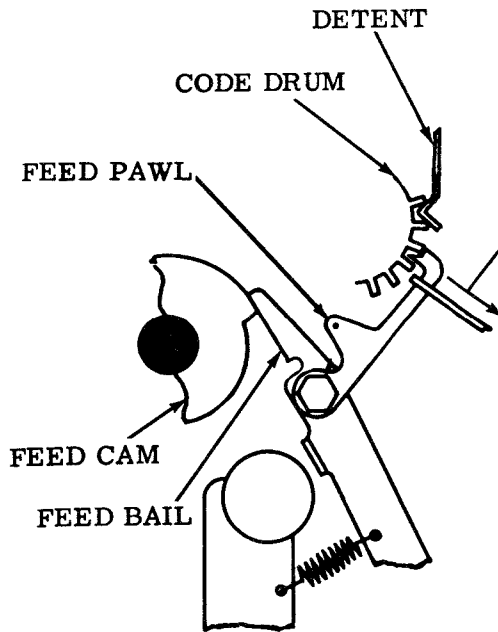

FEED PAWL SPRING

Requirement

With answer back in stop position and code drum in place

Min 1/2 oz---Max 1-1/2 oz
to start pawl moving.

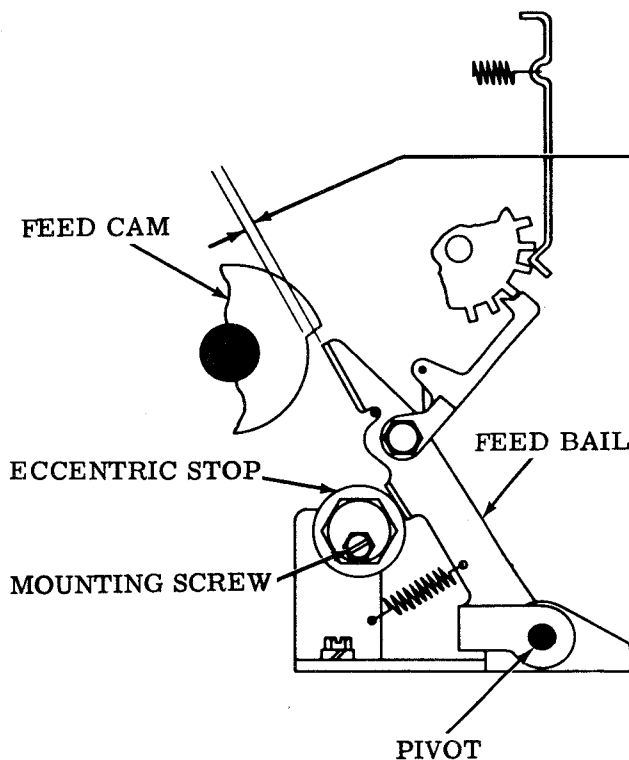

ECCENTRIC STOP POSITION

Requirement

With feed bail in lowest position of its travel opposite low part of its cam resting on eccentric stop, clearance between feed cam and feed bail.

Min 0.055 inch---Max 0.075 inch

To Adjust

Rotate eccentric with its mounting screw loosened.

Note: Keep high part of eccentric away from pivot point of feed bail to insure that eccentric stop bears against flat surface of bail extension and not on its lower edge.

2.05 Feed Mechanism (continued)

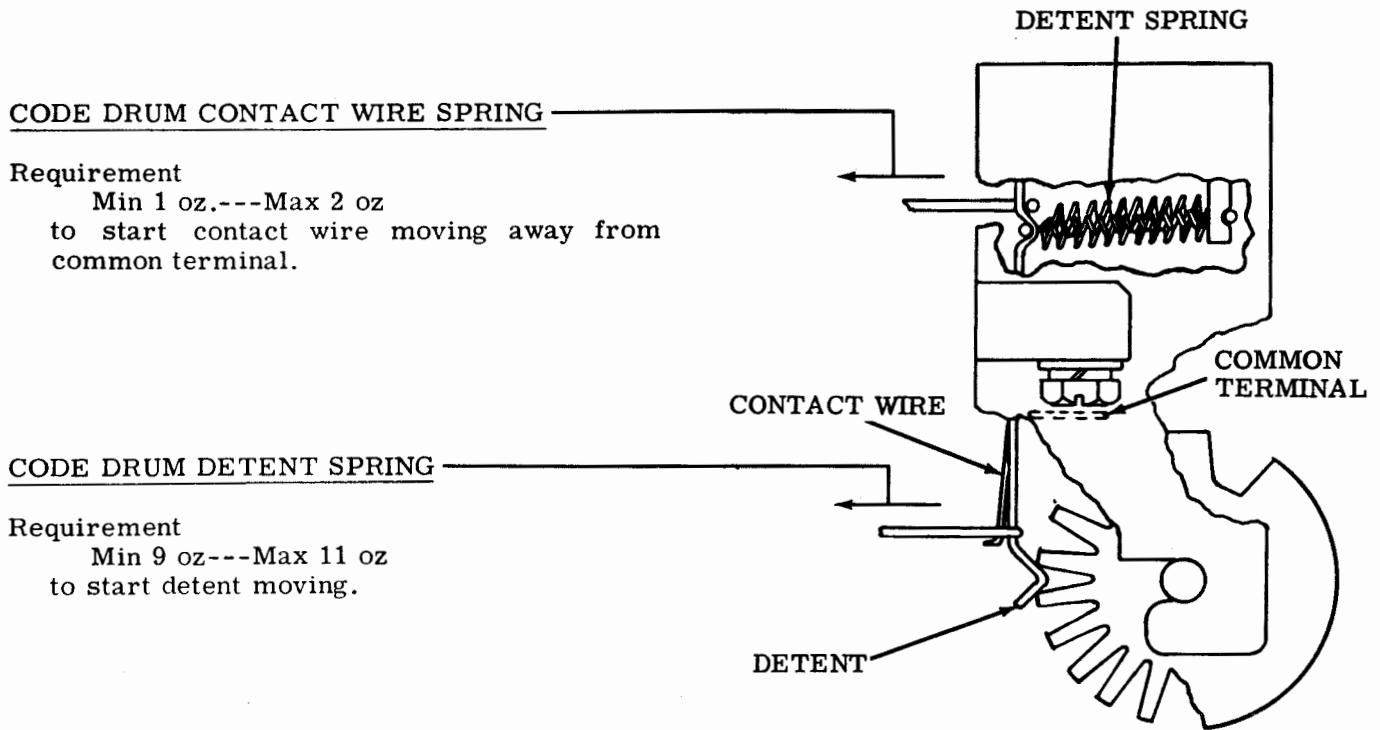

CODE DRUM CONTACT WIRE SPRING
 Requirement
 Min 1 oz.---Max 2 oz
 to start contact wire moving away from
 common terminal.

CODE DRUM DETENT SPRING
 Requirement
 Min 9 oz---Max 11 oz
 to start detent moving.

2.06 Relay Brackets and Contacts

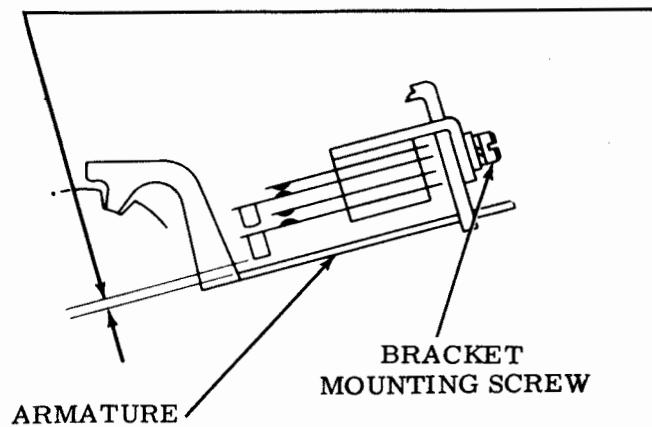

MOTOR HOLD AND RELAY PULL-UP CONTACT BRACKET

Requirement
 Trip magnet armature released clearance
 between insulator on contact and armature
 Min 0.015 inch---Max 0.030 inch

To Adjust
 Position contact bracket with its mounting
 screw loosened.

Note: Keep bracket parallel with armature.

2.07 Relay Brackets and Contacts (continued)

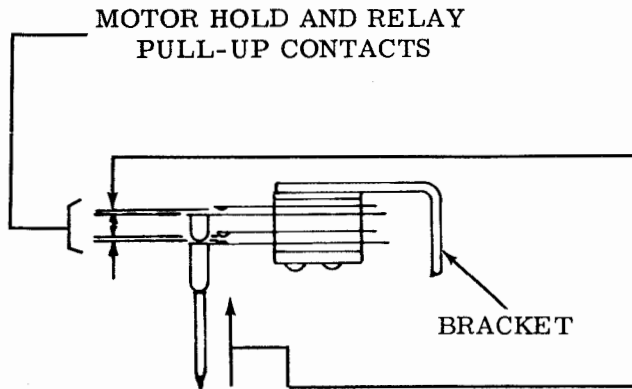
MOTOR HOLD AND RELAY PULL-UP CONTACT

Note: The adjustments are made before installation into the unit and should be checked or remade only in case of malfunction attributed to maladjustment of the contacts. If it should become necessary to remake the adjustment, the following procedure should be followed. Remove contact assembly with bracket from magnet yoke.

Requirements

- (1) The gap between the contacts in the unoperated position should be
Min 0.020 inch---Max 0.030 inch
- (2) Min 25 grams---Max 50 grams to close both contacts.

To Adjust

Bend contacts to meet requirements.

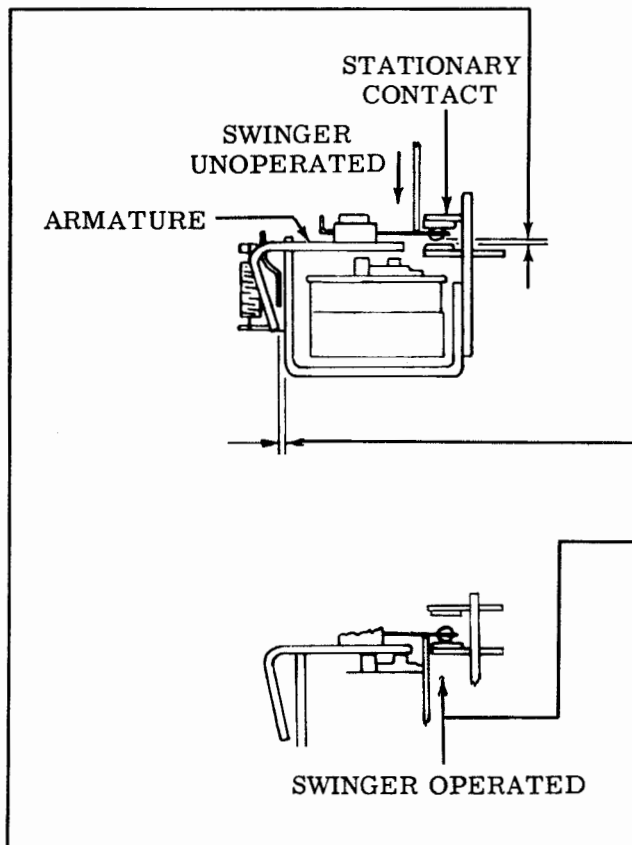
NONREPEAT RELAY

Note: These adjustments are made before installation into the unit and should be checked or remade only in case of malfunction attributed to maladjustment. If it should become necessary to remake the adjustment, the following procedure should be followed:

(1) Requirement

With armature released, clearance between armature stops and frame
Min 0.015 inch---Max 0.025 inch

(2) Requirement

The "make" contact (double) should close a minimum of 0.003 inch before the "break" (single) contact opens.

(3) Requirement

Minimum of 15 grams to move the swinger away from the stationary contacts when the armature is in either the operated or unoperated position.

(4) Requirement

The minimum contact gap should be 0.012 inch.

To Adjust

Bend armature stops, stationary contacts, and contact springs to meet requirements.

2.08 Distributor Brushes

DISTRIBUTOR BRUSH HOLDER

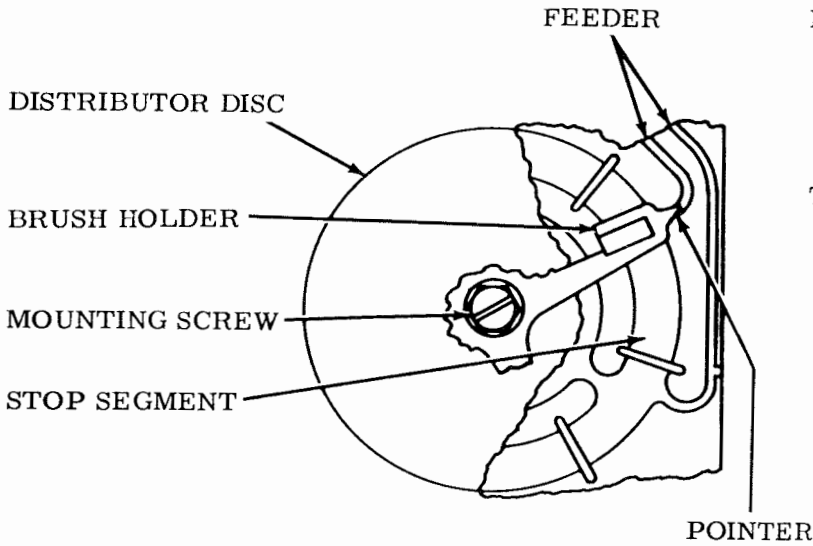

Requirement

With answer back in stop position, the pointer on the brush holder should point to the feeder of the stop segment.

To Adjust

Turn brush holder clockwise with its mounting screw loosened.

CAUTION: DO NOT TURN BRUSH HOLDER COUNTERCLOCKWISE. DAMAGE TO BRUSHES MAY RESULT.

BRUSH HOLDER SPRING

Requirement

New brush

Min 10-1/2 oz---Max 13-1/2 oz

Brush worn to 1/4 in. length

Min 7-1/2 oz---Max 10-1/2 oz

to start outer brush spring moving.

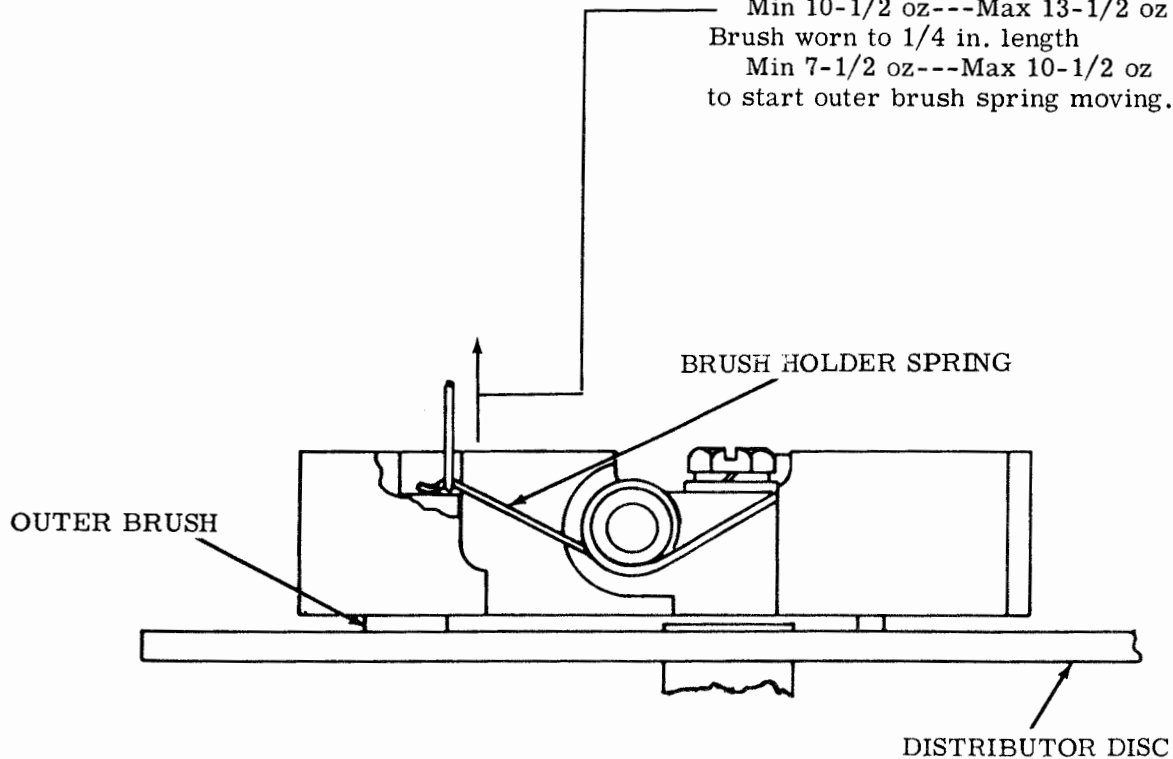

2.09 Gear Backlash

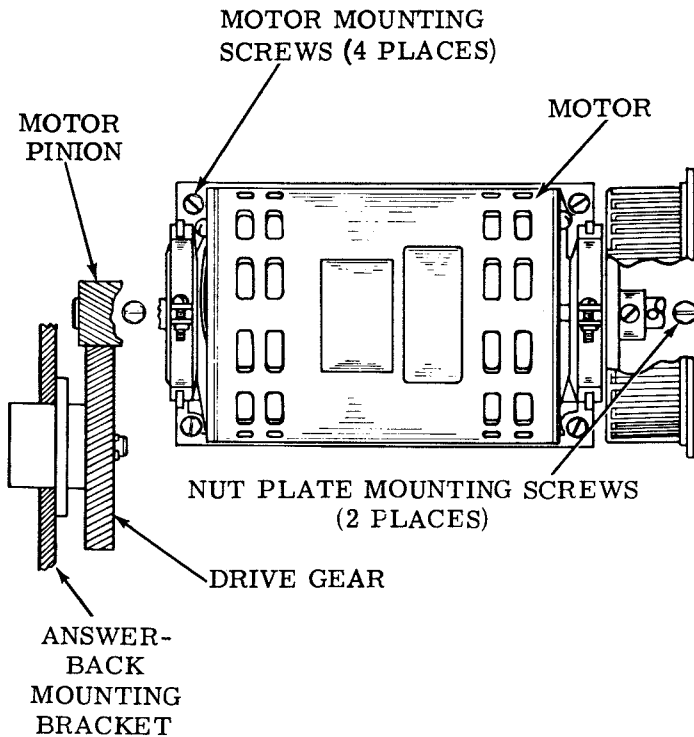

GEAR BACKLASH - SELF-CONTAINED UNIT

Requirements

- (1) Backlash between motor pinion and drive gear should be
Min 0.004 inch---Max 0.008 inch
- (2) Adjust for minimum noise.

To Adjust

With motor mounting and nut plate screws friction tight, position motor until requirements are met.

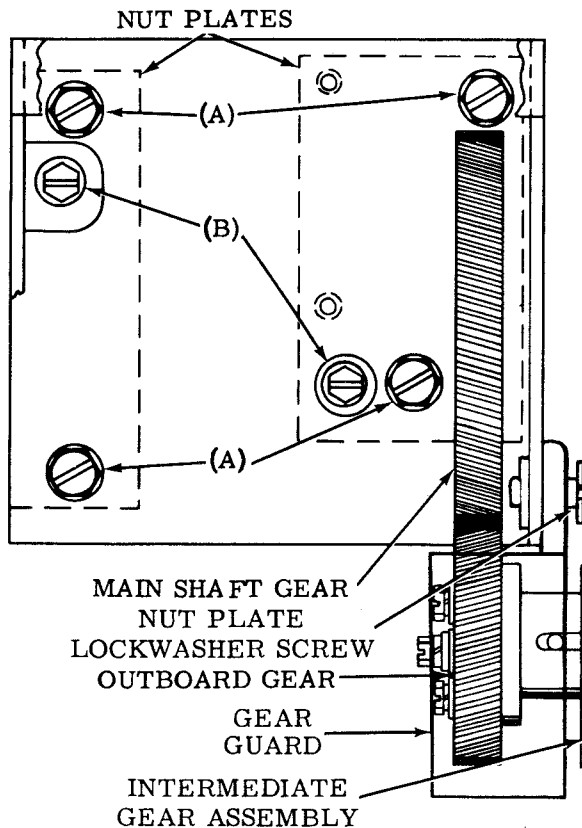

Note: The following adjustment is made after intermediate gear assembly to typing unit gear and motor pinion gear adjustments have been made.

GEAR BACKLASH - RO, KSR

Requirement

Backlash, at point of minimum clearance between answer-back main shaft gear and outboard gear of intermediate gear assembly on base

Min 0.004 inch---Max 0.008 inch
gauge by feel.

To Adjust

With two nut plate screws (B) friction tight, loosen four answer-back mounting screws (A). Move answer back all the way toward front in mounting holes. Tighten four answer-back mounting screws to friction tight and loosen two nut plate screws. Position assembly. Tighten all screws.

2.10 Gear Backlash (continued)

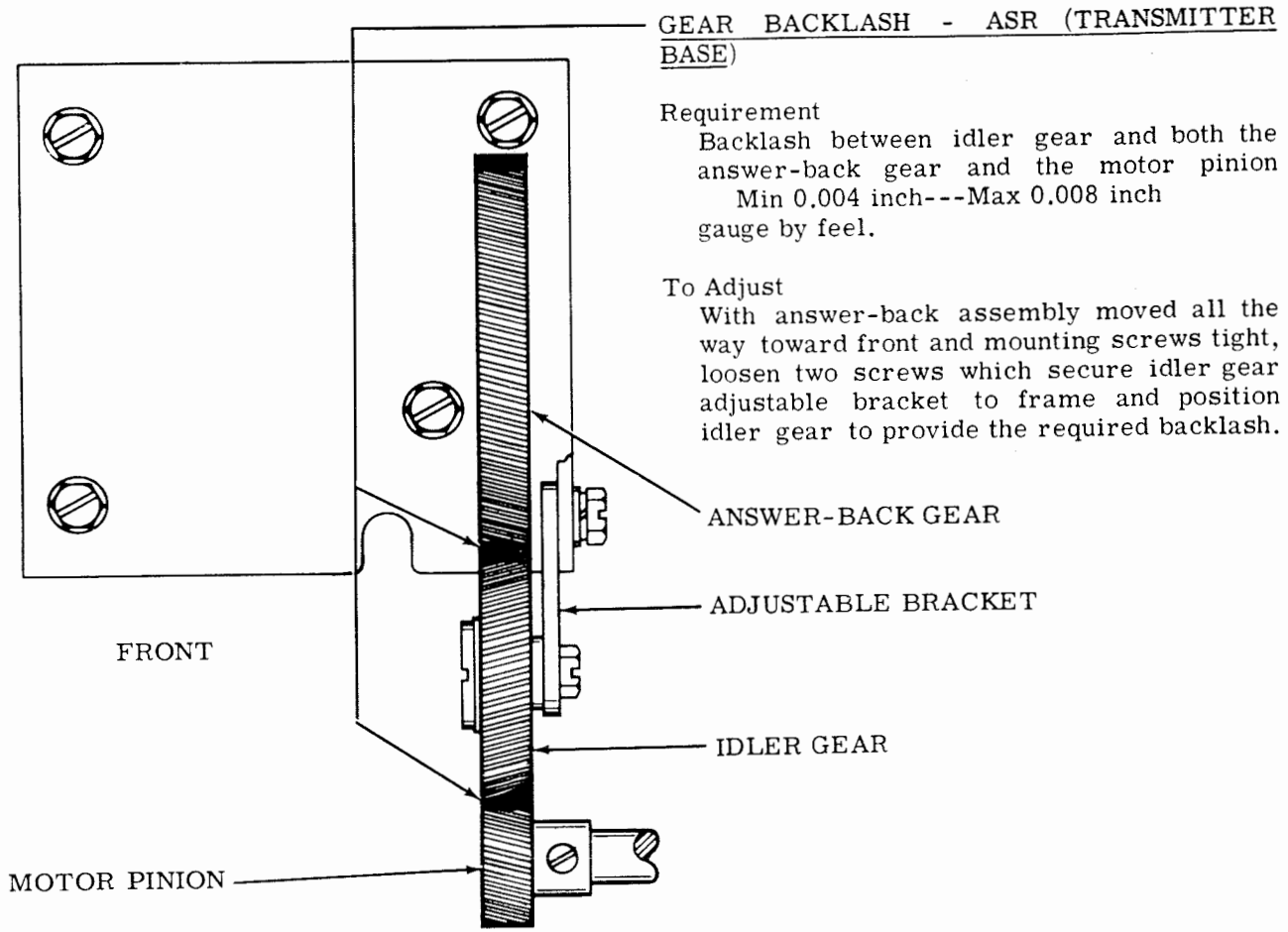

28 AND 35 ANSWER-BACK UNIT

LUBRICATION

CONTENTS	PAGE
1. GENERAL	1
2. BASIC UNITS	2
Drive gears	2
Drum feed mechanism	4
Main shaft	3
Motor	2

1. GENERAL

1.01 This section is reissued to provide instructions for lubricating the 5- and 8-level answer-back unit. Since this revision is of a general nature, marginal arrows have been omitted.

1.02 The general lubrication areas are illustrated by photographs. The specific points to receive lubricant are indicated on line drawings with appropriate textual instructions. Line drawings and textual instructions follow each photograph and are keyed to the photograph by paragraph numbers.

1.03 The answer-back unit should be lubricated just before placing it in service. After a few weeks of service, relubricate to make certain that all points receive lubrication.

1.04 Thereafter, the answer-back unit should be lubricated after a service period of 1500 hours or 6 months, whichever occurs first.

1.05 Use standard KS7470 oil and KS7471 grease at all locations where the use of oil or grease is indicated. Apply two drops of oil to each motor bearing every four months.

1.06 The unit should be thoroughly lubricated, but overlubrication, which might allow oil to drop or grease to be thrown on other parts should be avoided. The following general instructions supplement the specific lubrication points indicated:

(a) Apply one drop of oil to all spring hooks, except those used on electrical contacts, and the nine distributor block contact (wire contacts) tension springs.

(b) Apply oil to all pivot points, except the stop armature pivot area.

(c) Do not lubricate the distributor brushes and disc surface.

1.07 Exercise special care to prevent oil or grease from getting between the armature and pole piece of the clutch trip magnet. Keep all electrical contacts free from oil or grease.

1.08 Specific lubrication requirements and the amount of lubricant are indicated at each lubrication point in accordance with the following code:

01 Apply 1 drop of oil.

02 Apply 2 drops of oil.

03 Apply 3 drops of oil.

G Apply thin film of grease.

SAT. Saturate (felt oilers, washers, wicks) with oil.

2. BASIC UNITS

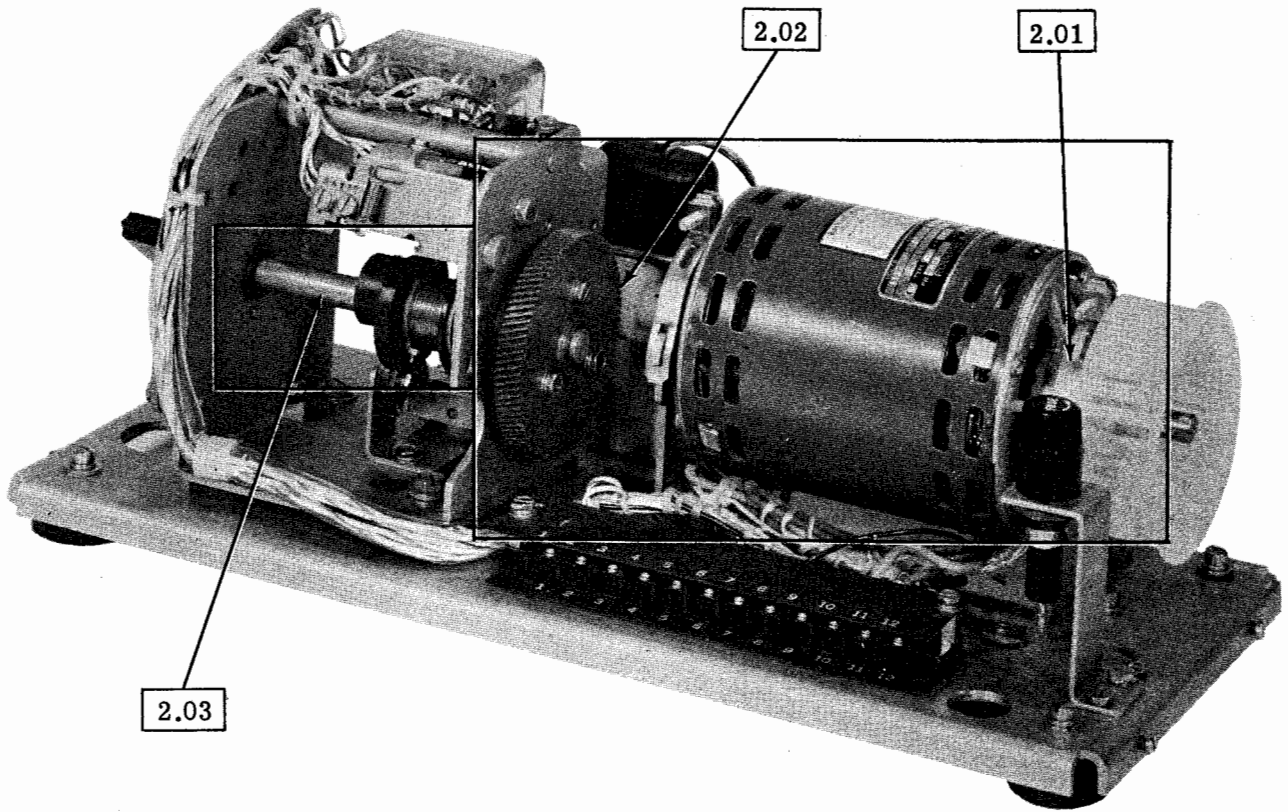

2.01 Motor (Lubricate Every Four Months)

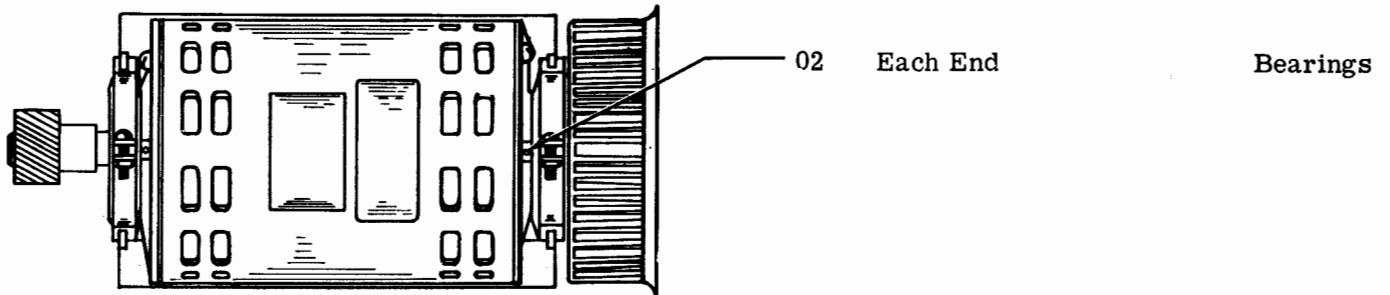

2.02 DRIVE GEARS

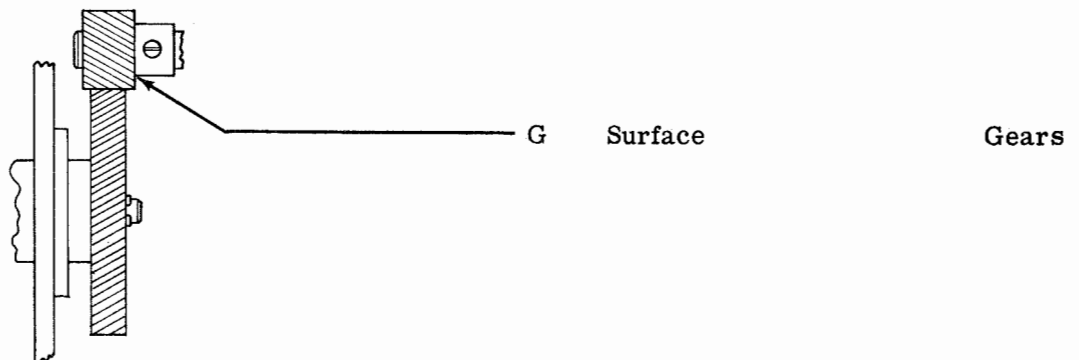

2.03 Main Shaft

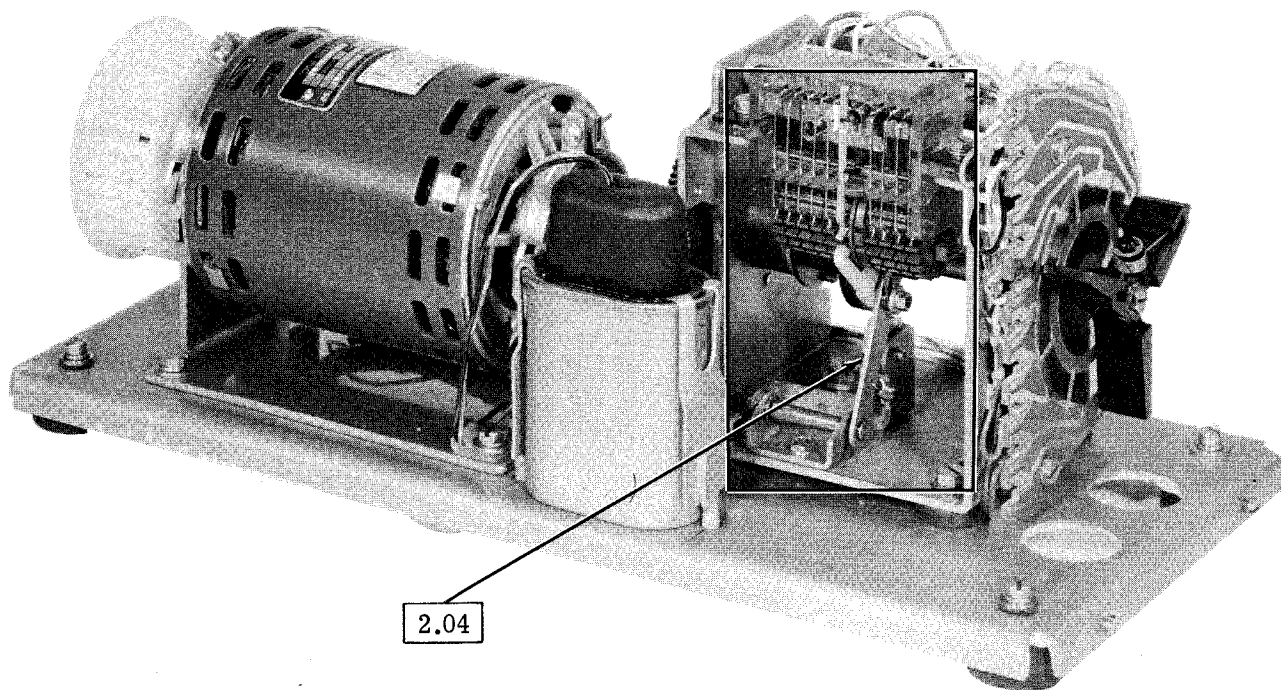
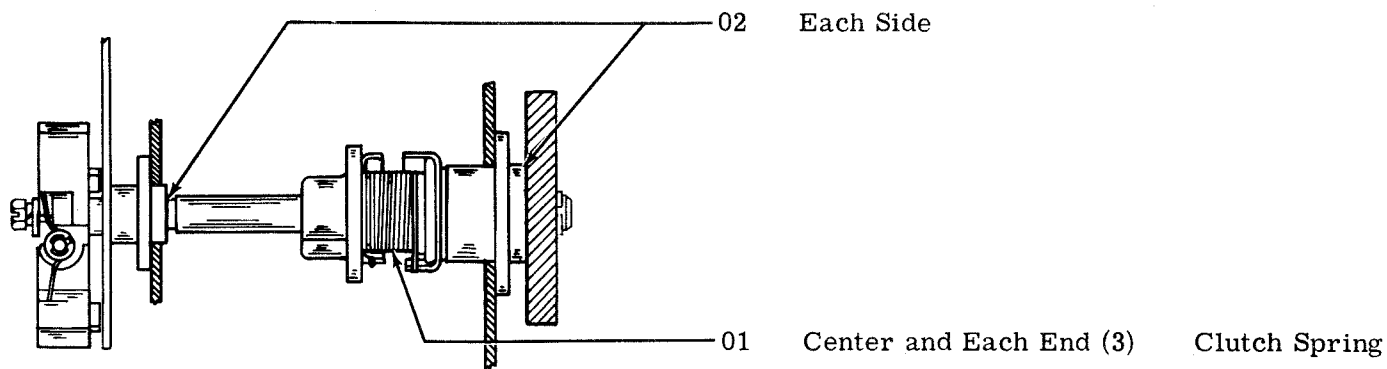

SECTION 574-235-701

2.04 Drum Feed Mechanism

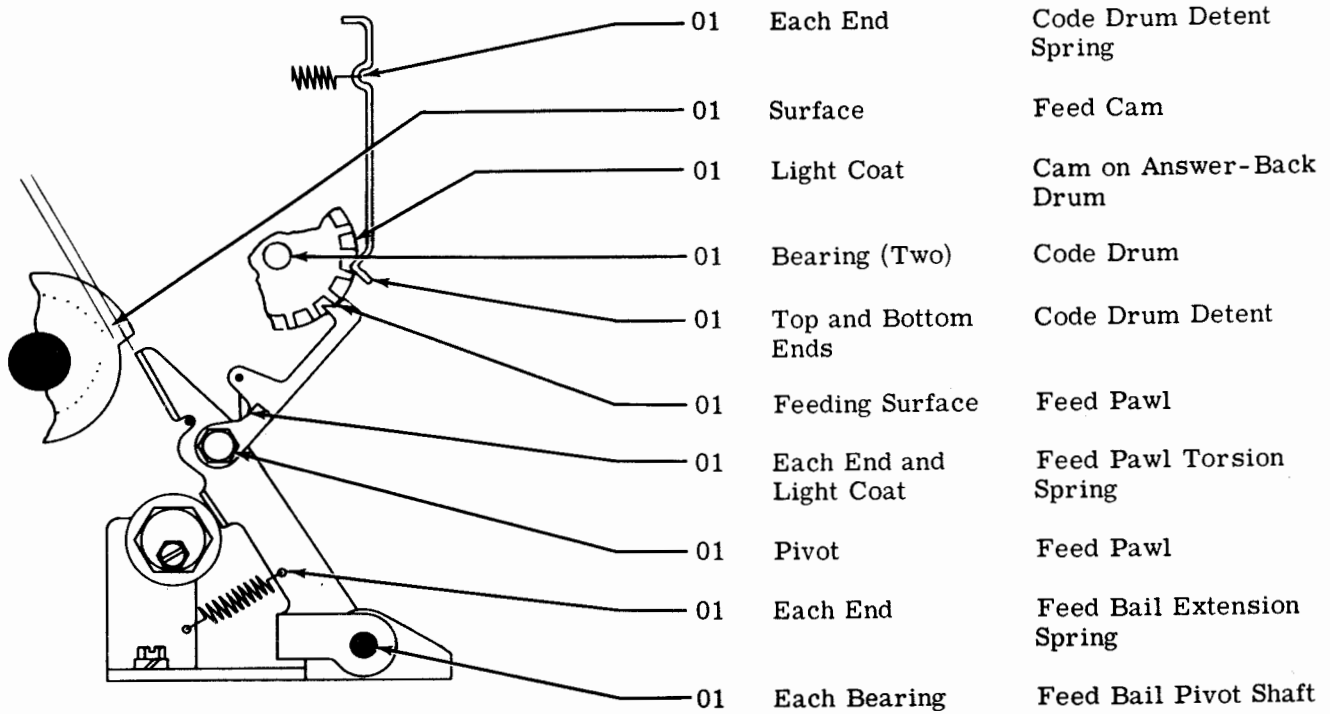

28 AND 35 ANSWER-BACK UNIT
DISASSEMBLY AND REASSEMBLY

CONTENTS	PAGE
1. GENERAL	1
2. DISASSEMBLY AND REASSEMBLY ..	1
COVER AND TERMINAL BLOCK ...	1
MOTOR AND MOTOR MOUNTING BRACKET	2
FUSE HOLDER AND BRACKET	2
CAPACITOR	2
CODE DRUM	2
CONTACT BLOCK	2
ANSWER-BACK MECHANISM	3
MAIN SHAFT	3

1. GENERAL

1.01 Disassembly, as outlined in this section, covers a procedure for removing the principle components which make up the answer-back unit.

1.02 The technician should refer to the exploded views found in the appropriate parts literature for an illustration of the unit to be disassembled, for location and visual identification of parts, and detailed disassembly and reassembly features.

1.03 Most maintenance, lubrication, and adjustments can be accomplished simply by removing the subject component from the unit. If possible, disassembly should be confined to components, which can, in some cases, be removed without disturbing adjustments. When reassembling the components, be sure to check all associated adjustments, clearances, and spring tensions.

1.04 Retaining rings (Tru-arcs) are made of spring steel and have a tendency to release suddenly when being removed. Loss of these retainers can be minimized as follows: Hold the retainer by hand to prevent it from rotating. Place the blade of a suitable screwdriver in the slot of the retainer. Rotate the

screwdriver in a direction to increase the diameter of the retainer for removal.

1.05 Avoid loss of springs in disassembly by holding one spring loop by hand while gently removing the opposite loop with a spring hook. Do not stretch or distort springs in removing them.

1.06 References made from left to right, up or down, and front or rear apply to the answer-back unit as viewed from the side with the answer-back mechanism to the left and the motor to the right.

2. DISASSEMBLY AND REASSEMBLY

2.01 In removing a component from the unit, the procedure followed and the location from which parts are removed must be carefully noted so that reassembly can be done correctly. Where no specific instructions are given for reassembly, reverse the procedure used in removing it.

COVER AND TERMINAL BLOCK

2.02 To remove the TP194792 cover and TP111289 terminal block, the following procedure should be used:

- (a) Loosen the four cover fastening screws and remove cover from base plate.
- (b) Remove the flat washers, lockwashers, and screws which secure the upper insulator to the terminal block. Remove upper insulator.
- (c) Remove the power and control cable spade type terminal lugs from under the screws on the terminal block.
- (d) Remove the studs, terminal block, and lower insulator from the base plate.

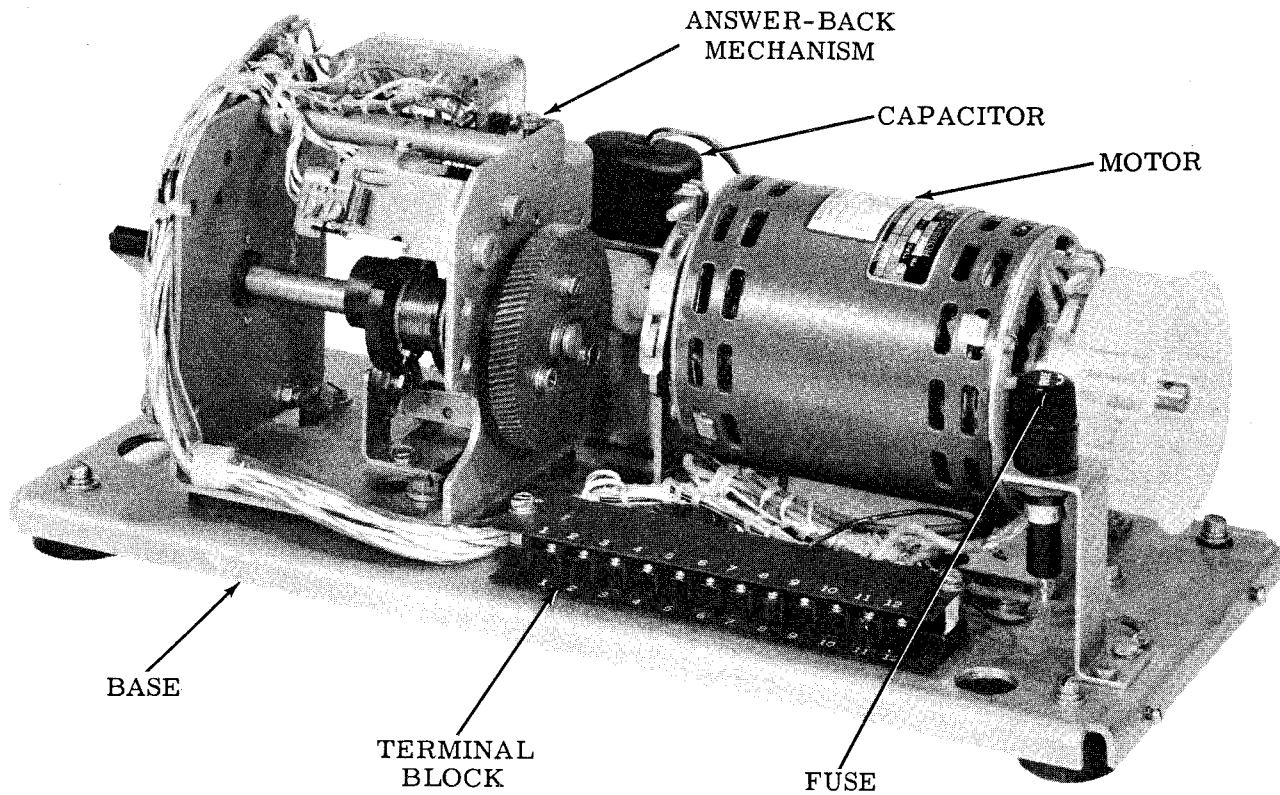

Figure 1 - Answer-Back Unit

MOTOR AND MOTOR MOUNTING BRACKET

2.03 Remove the TP192120 motor and TP192238 motor mounting bracket as follows:

- (a) Remove the two TP151620 motor mounting straps from each end of motor. Lift motor from mounting bracket.
- (b) Remove the four screws which secure motor mounting bracket. Lift bracket from base plate.

FUSE HOLDER AND BRACKET

2.04 Remove the TP116783 fuse holder and TP194814 fuse-holder bracket as follows:

- (a) Remove the nut from lower end of fuse holder, and lift from fuse-holder bracket.
- (b) Remove the two screws which secure fuse-holder bracket. Lift bracket from base plate.

CAPACITOR

2.05 To remove the TP192019 capacitor, remove the brackets from each side of capacitor and lift from base plate.

CODE DRUM

2.06 Remove the TP180827 code drum as follows:

- (a) Lift the answer-back brace by means of its extension, to deflect all contact wires and the detent away from the code drum.
- (b) Hold the feed pawl away and slip the code drum out. Do not overextend the feed pawl spring.

CONTACT BLOCK

2.07 To remove the TP180823 contact block, remove the screws, lockwashers, flat washers and spacers securing each side of the block and lift from bracket.

ANSWER-BACK MECHANISM AND BRACKET

2.08 Remove the three mounting screws from the TP194782 bracket and lift bracket and mechanism from base plate.

MAIN SHAFT

2.09 To remove the TP194784 main shaft from the answer-back mechanism proceed as follows:

(a) Remove the brush holder mounting screw, flat washer, and lockwasher. Remove the brush holder.

(b) Remove the three distributor disc mounting screws, flat washers, and lockwashers. Remove distributor.

(c) Remove the three mounting screws, flat washers, and lockwashers from the drive gear.

(d) Remove retaining ring, drive gear, and clutch sleeve by pulling over end of main shaft.

(e) Remove the mounting screws, flat washers, and lockwashers from each bearing on the main shaft and remove each bearing.

(f) Rotate main shaft until the flat portion of the motor hold cam is adjacent to the feed bail. Withdraw the shaft to the left until the right gear end clears the bracket. Slide shaft out from beneath the trip magnet.

