

**BULLETIN 249B**

**DESCRIPTION AND  
PRINCIPLES OF OPERATION  
PERFORATOR TRANSMITTER  
MODEL 28 AUTOMATIC SEND-RECEIVE (ASR)  
TELETYPEWRITER SETS  
LAK, LPE, LTPE, LCXB, LRB, LAAC**



**TELETYPE  
CORPORATION**  
5555 TOUHY AVENUE, SKOKIE, ILLINOIS

September 1967

## INTRODUCTION

Bulletin 249B provides description and principles of operation for the component units peculiar to the 28 Automatic Send-Receive (ASR) Teletypewriter Sets.

The Bulletin is made up of a group of appropriate independent sections. The sections are complete within themselves; they are separately identified by title and section number and the pages of each section are numbered consecutively, independent of other sections.

The identifying number of a section, a 9-digit number, appears at the top of each page of the section, in the left corner of left-hand pages and the right corner of right-hand pages.

To locate specific information, refer to the table of contents. Find the name of the involved component in column one and the title of the section in column two. The correct 9-digit section number will then be found in column three. The sections are arranged in the order shown in the table of contents. Turn to page one of the section indicated where the contents of that section will be found (except where a section is small and does not require a listing of contents).

## TABLE OF CONTENTS

Title	Contents	Section	Issue
28 Automatic Send-Receive (ASR) Teletypewriter Set	Description	573-101-100TC	1
28 Perforator-Transmitter Base	Description and Principles of Operation	573-117-100TC	1
28 Auxiliary Typing Reperforator Base (ASR)	Description	573-121-101TC	1
28 Transmitter Distributor Base (ASR)	Description	573-128-100TC	1
28 Teletypewriter Cabinet for ASR Sets	Description	573-134-101TC	1
28 Typing and Nontyping Perforator	Description and Principles of Operation	573-139-100TC	1

Note: For motors, refer to Bulletin 295B.

This page intentionally left blank

28 AUTOMATIC SEND-RECEIVE (ASR) TELETYPEWRITER SET

DESCRIPTION

CONTENTS	PAGE	CONTENTS	PAGE
1. GENERAL . . . . .	1	TYPING UNIT RIBBON . . . . .	11
2. CONFIGURATION . . . . .	4	TYPING UNIT PAPER (FRICTION FEED) . . . . .	11
3. COMPONENTS . . . . .	4	TAPE SPECIFICATIONS . . . . .	11
TYPING UNIT . . . . .	4	PRINTED CHARACTERS (TAPE) . . . . .	11
KEYBOARD . . . . .	4		
TAPE PUNCH UNITS . . . . .	4		
TRANSMITTER DISTRIBUTORS . . . . .	5	1. GENERAL	
ELECTRICAL SERVICE UNIT . . . . .	5	1.01 This section describes the general configuration and capabilities of the 28 Automatic Send-Receive (ASR) Teletypewriter Set. It includes a brief description of the ASR Set components, which are covered in detail in separate sections, the important variable features, a general description of operation, and the appropriate technical data. Because of the many variations possible, the ASR Set described in the text and illustrations is typical.	
MOTOR UNITS . . . . .	5	1.02 The 28 ASR Set is an electromechanical apparatus capable of operating as a self-contained message originating and receiving center. It is used to exchange printed and tape perforated messages between two or more stations connected by appropriate transmission facilities (telegraph lines, telephone networks, and radio channels) (Figures 1 and 2).	
CABINET . . . . .	5	1.03 Messages are received electrically via the transmission facility and are printed on page-size copy paper or continuous business forms. With page-printed monitoring, the ASR Set can electrically transmit messages which are originated by either perforated tape or keyboard operation. Messages may be perforated and printed on tape for separate transmission with or without simultaneous transmission and page-printed monitoring.	
4. VARIABLE FEATURES . . . . .	6	1.04 Certain ASR Sets are equipped to receive messages in printed and perforated tape form and, at the same time, prepare tape off-line.	
5. OPERATION . . . . .	6		
GENERAL OPERATION . . . . .	6		
SELECTIVE CALLING . . . . .	9		
6. TECHNICAL DATA . . . . .	9		
SIGNAL REQUIREMENTS . . . . .	9		
POWER REQUIREMENTS (TYPICAL) . . . . .	9		
OPERATING SPEEDS . . . . .	9		
APPROXIMATE DIMENSIONS (INCHES) . . . . .	9		
APPROXIMATE WEIGHT (POUNDS) . . . . .	9		
PRINTED CHARACTERS (TYPING UNIT) . . . . .	10		
PLATENS . . . . .	10		
SPROCKET FEED PLATENS . . . . .	10		

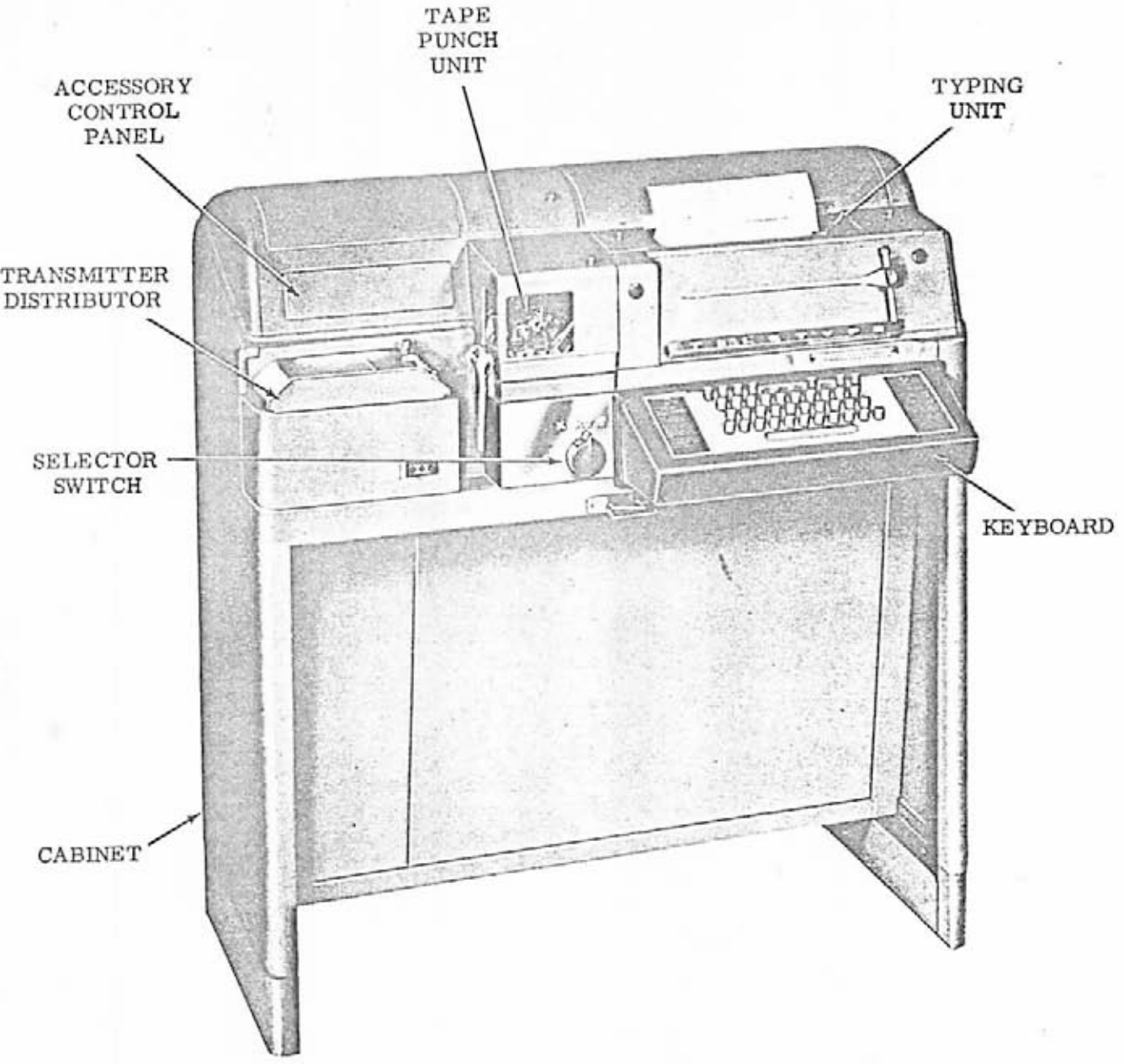

Figure 1 - Typical 28 Automatic Send-Receive (ASR) Teletypewriter Set

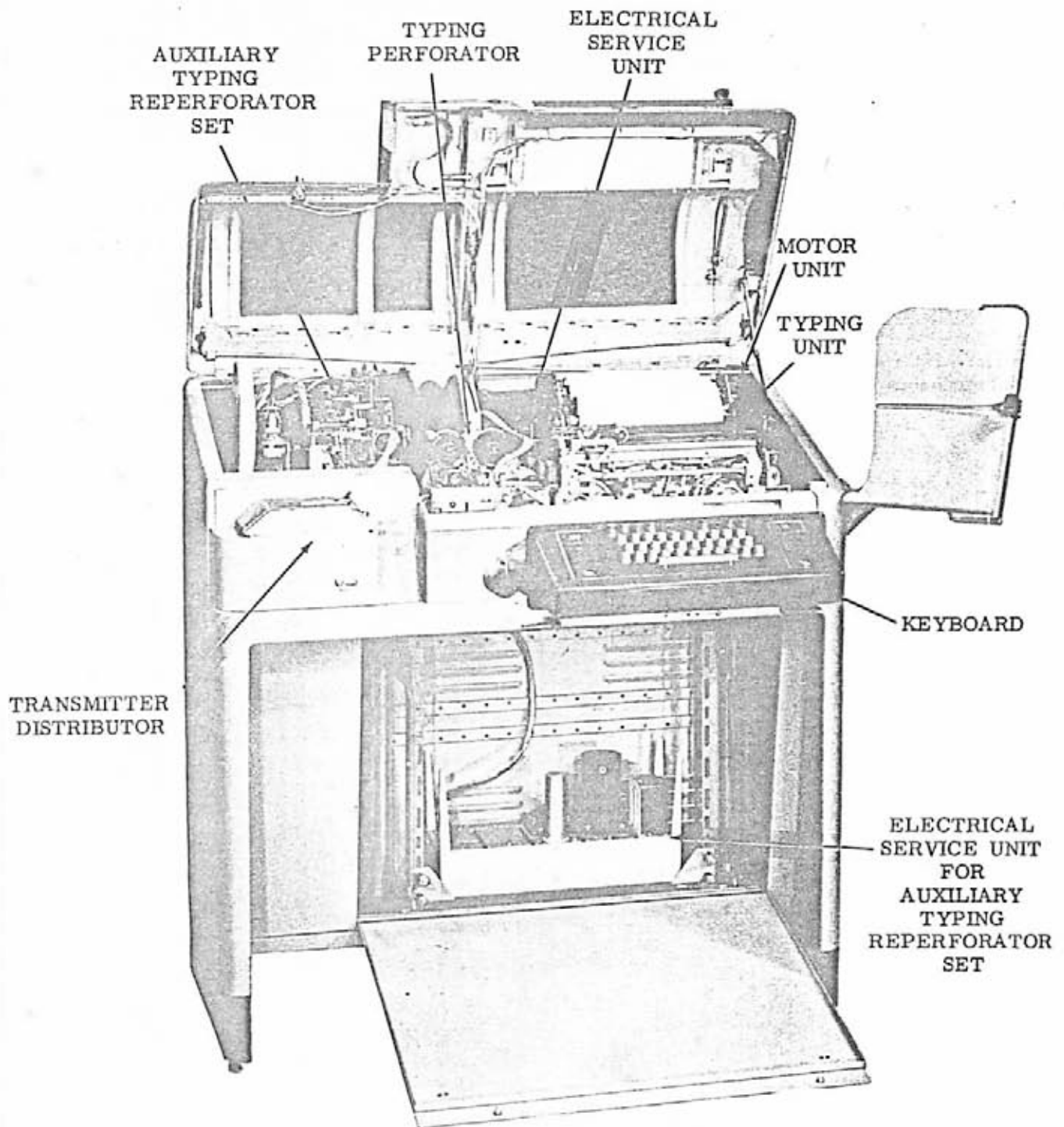

Figure 2 - Typical 28 Automatic Send-Receive (ASR) Teletypewriter Set (Interior View)

1.05 Transmission between stations is accomplished electrically using the Baudot teletypewriter signaling code. The ASR Set operates at speeds up to 100 words per minute.

1.06 Reference should be made to the appropriate sections which describe in detail the various ASR Set components.

1.07 References to left or right and front or rear views are made from a position in front of the ASR Set.

## 2. CONFIGURATION

2.01 The ASR Set is made up of a group of components using a basic arrangement. These components, described in Part 3, are:

- (a) Keyboard
- (b) Typing Unit
- (c) Perforator (tape punch)
- (d) Transmitter-Distributor
- (e) Electrical Service Unit
- (f) Motor Unit
- (g) Cabinet

2.02 To meet varying installation and operational requirements, the selection of the particular kind of component is often varied, but without changing the basic arrangement. The transmitter distributor, for example, may be any one of the following units:

- (a) Fixed Head Single Contact
- (b) Pivoted Head Multicontact
- (c) Fixed Head Multicontact
- (d) Pivoted Head and Fixed Head Multicontact

2.03 The perforator (or reperforator) used may be any one of the following four available units:

- (a) Nontyping Perforator
- (b) Typing Perforator
- (c) Nontyping Reperforator
- (d) Typing Reperforator

2.04 Variations in typing units include friction feed and sprocket feed units. Motor units are either ac synchronous or dc governed.

2.05 A number of special and optional features are available with the ASR Set. However, these do not affect the basic arrangement of components.

2.06 An addition to the basic component arrangement of the ASR Set is the inclusion of an Auxiliary Typing Reperforator Set. Space is provided in the cabinet for this completely independent receiving unit. Refer to Part 3 for a description of this set.

## 3. COMPONENTS

3.01 The ASR Set is made up of seven basic components which, because of operational requirements, may vary in features from one installation to another (Part 2). These components are briefly described in the following paragraphs. A complete description including principles of operation appears in the appropriate sections.

### TYPING UNIT

3.02 The typing unit contains the mechanisms necessary for translating electrical input signals into printed, alphanumeric characters or functional control operations. The unit may be equipped to accommodate either friction or sprocket feed paper, in single or multicopy form, either rolled or fan folded. It includes a stunt box that provides nonprinting functions such as case shifting, carriage return and line feed and, in addition, switching facilities for remote controls, station selection, and other applications.

### KEYBOARD

3.03 The keyboard contains the mechanisms for generating and transmitting a teletypewriter signal. It also provides mounting facilities for the typing unit, one of four tape punch units, a motor unit, and the necessary driving gears and cross-shafts. Typing and perforating functions originate from the operation of keytops.

### TAPE PUNCH UNITS

3.04 One of four different tape punch units is available with the ASR Set. These receiving-only units contain the mechanisms that translate electrical or mechanical inputs into



perforations in the tape or both perforations and printed characters. The tape prepared by the units may be either fully perforated or partially perforated (chadless).

3.05 Two of the units are perforators and are operated and actuated mechanically by the keyboard. The nontyping perforator prepares only perforations in the tape. The typing perforator, in addition to perforating the tape, types messages on the tape.

3.06 The remaining two units available are reperforators, which are equipped with a selector mechanism to receive inputs electrically. The nontyping reperforator prepares only perforations in the tape. The typing reperforator produces perforations and types on the tape. They may also be actuated mechanically.

3.07 The ASR Set may be equipped with an Auxiliary Typing Reperforator Set. This completely independent set contains the following components:

- (a) Typing reperforator unit.
- (b) Base (with gears, terminal boards, controls; on some sets controls are on a panel mounted on the front of the cabinet).
- (c) Electrical service unit (installed in the lower right side of the cabinet).
- (d) Motor unit (a variable speed gear shift mechanism is available with some units. This allows selection of 60, 75, or 100 word per minute speeds).

#### TRANSMITTER-DISTRIBUTORS

3.08 A transmitter distributor contains the necessary mechanisms to advance the tape, read its perforations, and to convert these into teletypewriter signals. The transmitter distributor is installed on a separate base, but receives motive power from the keyboard-mounted motor unit. The unit is controlled by a three-position start-stop switch which is accessible to the operator. The ASR Set uses one of four available transmitter distributors:

- (a) Fixed Head Single Contact: Contains a stationary tape reading head and a single-contact distributor. Output is sequential.
- (b) Pivoted Head Multicontact: Tape reading head and signal distributor may be actuated independent of each other by local or

remote control. Unit is always used in conjunction with a punching unit because the pivoted reader can move along the tape, read and transmit the last character punched. This unit is used frequently with continuous tape loops. Output from the transmitter distributor is in sequential or parallel form.

(c) Fixed Head Multicontact: Tape reading head and signal distributor may be actuated independent of each other by local or remote control. Output from transmitter distributor is in sequential or parallel form. Signal distributor also accepts external parallel inputs and converts them to serial form.

(d) Pivoted and Fixed Head Multicontact: This consists of two tape reading heads (one stationary, the other pivoted) and a single-contact signal distributor. The pivoted head is mounted in line with and accepts tape directly from the ASR Set punch unit. The stationary tape head is accessible externally for manual insertion of tape from any source. This arrangement permits the combining of inputs, such as standard and variable data. Output from the signal distributor is in sequential form.

#### ELECTRICAL SERVICE UNIT

3.09 The electrical service unit serves as the area of concentration for the wiring of the ASR Set, and provides mounting facilities for various electrical assemblies and components. It may include such optional assemblies as a line (polar) relay, line shunt relay, and line test key. The set's main power switch, convenience outlet and fuse, terminal blocks, and interconnecting cables may also be included.

#### MOTOR UNITS

3.10 The motor units that provide mechanical motion for the ASR Set are of two basic types: ac synchronous and ac/dc series governed. The ac synchronous motor is used when the power source is regulated; the ac/dc series governed motor operates from either regulated or unregulated power. The latter is required where only unregulated power is available. The units operate at the same speed and are rated heavy-duty to accommodate the set's load requirements.

#### CABINET

3.11 The components of the ASR Set are enclosed in a floor mounted cabinet which includes space for an Auxiliary Typing Reperfo-

erator Set and other optional equipment, and for accessories such as paper and tape handling equipment.

#### 4. VARIABLE FEATURES

4.01 A wide variety of optional features are available with the ASR Set. These features, which provide special, nonprinting operations or control facilities, or serve as an aid in operation, are in most cases readily installed in the field. Some of the features are described briefly below.

- (a) Horizontal Tabulator: Permits rapid movement of the typing unit typebox to predetermined positions on the copy paper.
- (b) Vertical Tabulator: Advances a form to any predetermined position within the form.
- (c) Form Feed-Out: Advances a form to the first printing line on the succeeding form from any point on the previous form.
- (d) Automatic Carriage Return-Line Feed: These functions occur simultaneously should the sending station fail to initiate them, when the typebox reaches the right margin.
- (e) Contact Mechanisms: A number of electrical contact mechanisms are available to provide control of external equipment or for other special applications. These include code reading, timing, auxiliary, and letters-figures contact mechanisms.
- (f) Tape Feed-Out Mechanism: This mechanism may be installed on the tape punch units. It operates automatically or manually to feed out a length of blank or letters perforated tape for convenience in tape handling. Tape feeding may be either interfering or noninterfering.
- (g) Back Space Mechanism: This mechanism, operated manually or with power-drive, retracts tape back through the punch block to allow erroneously perforated data to be obliterated by replacement with the letters code combination.
- (h) Accessories: A number of accessories are available to facilitate paper, tape, and form handling, including low-supply indicator alarms, special trays and shelves, chad chutes, and paper winders.

#### 5. OPERATION

##### GENERAL OPERATION

5.01 The components are interconnected electrically or mechanically to provide a wide range of possibilities for sending, receiving or storing teletypewriter messages. Electrical connections between the components are routed through the electrical service unit. Transmitted signals are initiated through the keyboard or the transmitter distributor (Figure 3).

5.02 Received signals are recorded by the typing unit which also monitors local, off-line transmissions. The tape punch (typing or nontyping perforator or reperforator unit) prepares tape on which received or locally prepared messages may be stored for future transmission by the transmitter distributor.

5.03 The keyboard, tape punch unit, typing unit, and transmitter distributor receive their motive power from a single motor unit.

5.04 A three-position mode selector switch, mounted on the front panel of the cabinet, permits the operator to place the ASR Set into one of three operating conditions:

- (a) Keyboard (K): Placing the selector switch in the K (keyboard position) conditions the ASR Set so that messages may be transmitted from the keyboard. All messages transmitted are recorded on the typing unit.
- (b) Keyboard-Tape (K-T): Placing the selector switch in the K-T (keyboard-tape position) enables the ASR Set to transmit from its keyboard and, at the same time, record all transmission in both punched tape and page-printed form.
- (c) Tape (T): Placing the selector switch in the T (tape position) conditions the ASR Set so that operation of the keyboard produces punched tape only. No external transmissions occur. However, the typing unit is operable and will record all received messages.

5.05 The transmitter distributor is controlled by a start-stop switch which is accessible for operation by the operator. Transmissions are automatically stopped by tight-tape or tape-out devices, which are incorporated in the transmitter distributor, should these tape conditions occur.

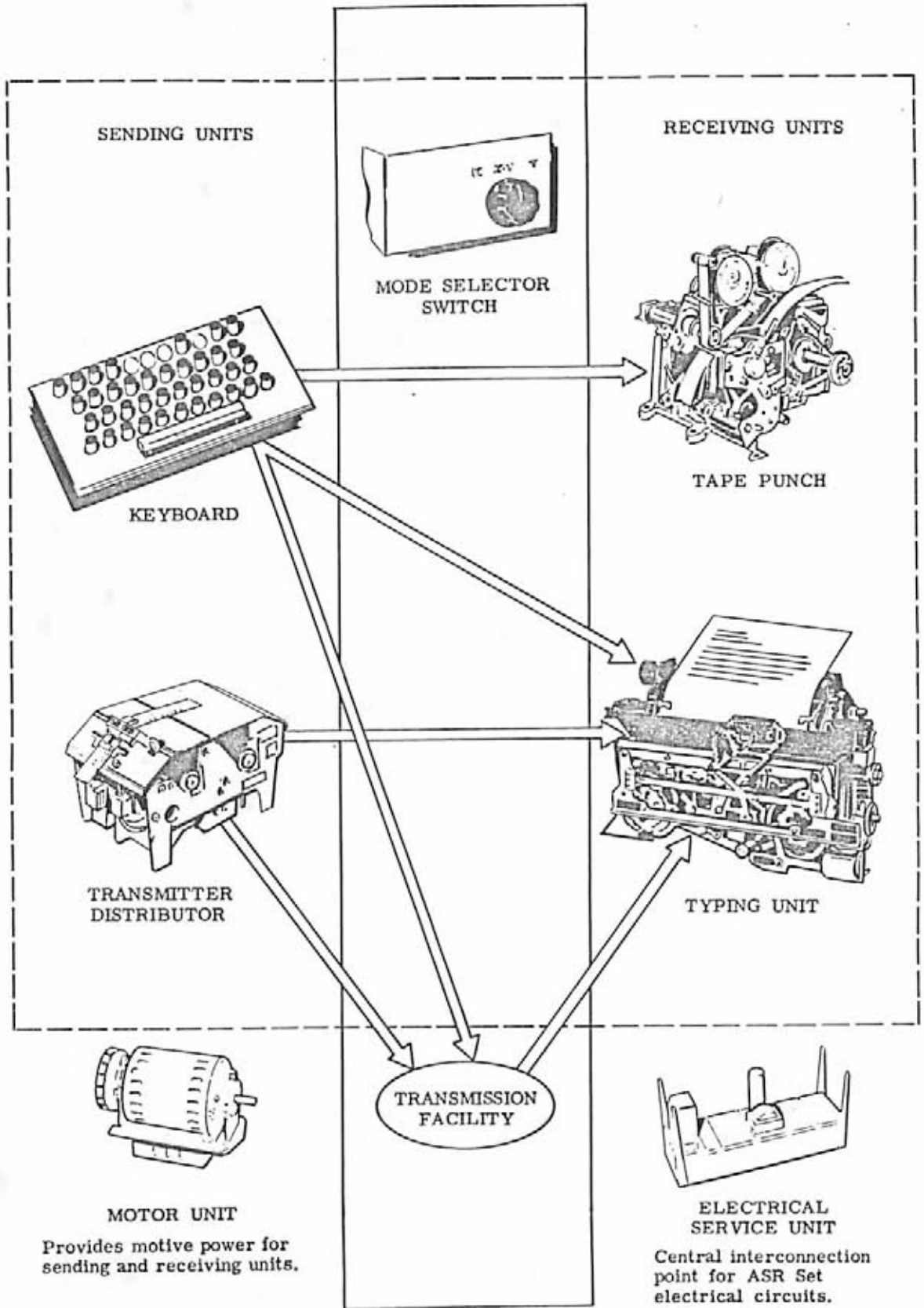

**K**  
  
 Messages are transmitted from the keyboard and recorded on the typing unit. Received messages are recorded on the typing unit.

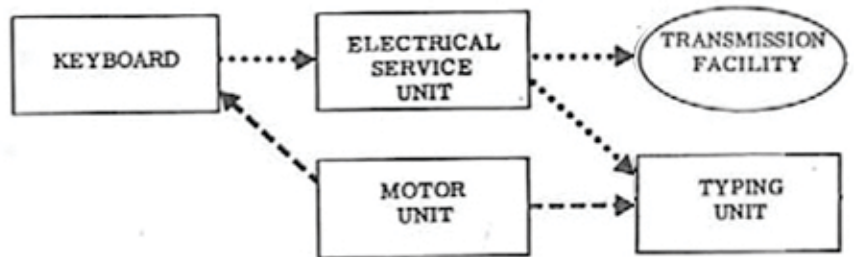

**K-T**  
  
 Messages are transmitted from the keyboard and recorded on both the typing unit and tape punch unit (perforator or reperforator). Perforator (illustrated) is actuated mechanically; reperforator is actuated electrically and may be used, as can the typing unit, to record received messages. Reperforator may also be actuated mechanically.

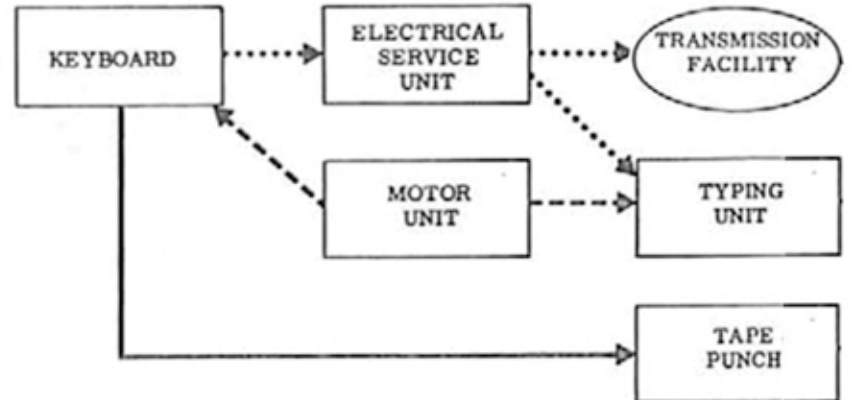

**T**  
  
 No external transmissions occur. Messages typed on the keyboard are recorded by the tape punch unit. Received messages are recorded on the typing unit, and/or reperforator.

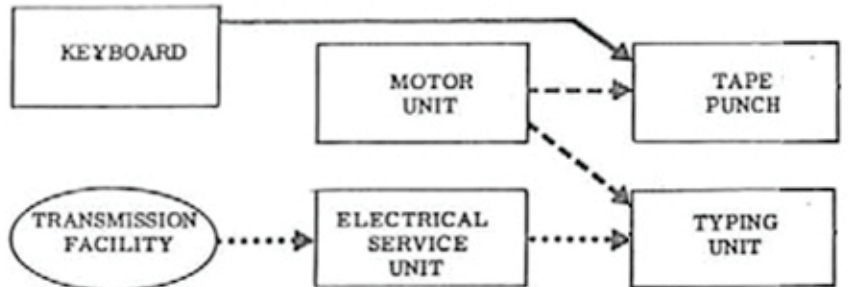

**TRANSMITTER DISTRIBUTOR OPERATION**  
  
 The transmitter distributor, controlled by a start-stop switch, may be operated in place of the keyboard in all operating modes. Transmitted messages are recorded by the typing unit and reperforator-type tape punch unit.

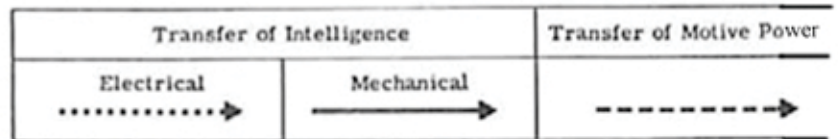
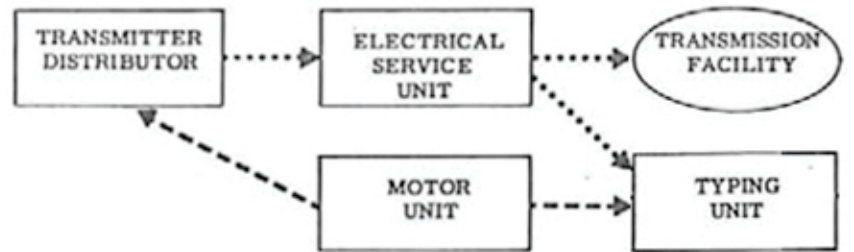

Figure 3 - Typical 28 ASR Set Components and Operating Methods

5.06 Control of the optional Auxiliary Typing Reperforator Set is provided either by controls located on the accessory control panel on the front of the cabinet, or by controls located on the typing reperforator base and accessible through a cabinet access lid. The Auxiliary Typing Reperforator Set is connected to a separate signal line circuit and may therefore receive and record messages simultaneously with but independent of other ASR Set operations.

#### SELECTIVE CALLING

5.07 ASR Sets may be equipped to operate in a selective calling system. Selective calling operation is a method of message transmission control in which traffic is selectively directed only to those sets actually concerned with the information being transmitted. Each set in the circuit, which may be standard line or radio, is assigned an identification code. The code may be made up of any character or sequence of characters. Recognition of this code, and other selective calling codes, is made by the stunt box in the typing unit of each set. The typing unit, upon recognition of the proper code, will be placed in the select-nonprint condition. When this occurs, direct printing is suppressed while the selector mechanism and the stunt box remain active. In this way, the typing unit monitors signal line conditions but does not respond, either to print or to perform

a function, until it receives instructions in the form of selective calling code sequences.

## 6. TECHNICAL DATA

### SIGNAL REQUIREMENTS

Code: Baudot (five level start-stop); sequential.

Input:

- (1) Neutral - Selector magnets directly connected to signal line, or through line relay.
- (2) Polar - Line relay or selector magnet driver required.

Line Current: 20, 30, or 60 milliamperes.

### POWER REQUIREMENTS (TYPICAL)

Sets with Synchronous Motor Units - 115 v ac  $\pm 10\%$ , 60  $\pm .75\%$  cycles, single phase.

Sets with Governed Motor Units

- (1) 115 v ac  $\pm 10\%$ , 50-60 cycles, single phase.
- (2) 115 v dc with external resistance.

#### OPERATING SPEEDS

Characters or Operations	Per-Minute	600	460	428	404	400	390	368
	Per-Second	10.0	7.7	7.1	6.7	6.7	6.5	6.1
Unit Code		7.42	7.42	7.00	7.42	7.50	7.00	7.42
Bauds (Bits-per-second)		74.2	56.9	50.00			45.5	
Frequency (Cycles/Second)		37.1	28.4	25.00			22.8	
Length in Milliseconds	One Character	100	130	140	149	150	154	163
	Unit Pulse	13.5	17.6	20.0	20.0	20.0	22.0	22.0
	Stop Pulse	19.1	24.9	20.0	28.5	30.0	22.0	31.2

#### APPROXIMATE DIMENSIONS (INCHES)

Height	Width	Depth
39	36	18-1/2 (less keyboard which extends 4-1/2 inches)
(See Figure 4 for dimensional details.)		

#### APPROXIMATE WEIGHT (POUNDS)

Total Weight	260
Shipping Domestic	530
Export	600

SECTION 573-101-100TC

PRINTED CHARACTERS (TYPING UNIT)

Type Pallet Arrangements - Standard, Upper Case Arrangements Include:

- (1) Communications (punctuation symbols)
- (2) Fractions
- (3) Weather symbols

Individual pallets for upper and lower case characters are available separately for field installation.

Type Styles and Spacing (Typical)

Style	Character Height		Horizontal Characters Per Inch		Vertical Lines Per Inch	
	Caps	Fraction	Single	SPACE - Double	Single	FEED - Double
Murray	.103"	.162"	10	5	6	3
Gothic	.103"	none	10	5	6	3
Gothic	.103"	.162"	12	6	6	3
Long Gothic	.120"	.170"	10	5	6	3
Large Gothic	.180"	.180"	10	5	-	3

PLATENS

Physical Characteristics	Friction Feed	Sprocket Feed
Construction	Rubber covered cylinder, fixed to platen shaft.	Rubber covered cylinder, free on platen shaft.
Length	8-3/4"	Selected for desired form width.
Paper Width	Any width up to 8-1/2"	Minimum: 3-5/8" Maximum: 9"
Characters per line (10 per inch)	Margin is adjustable from 1 to 85 characters	Margin is adjustable from 1 to maximum number indicated in chart.

SPROCKET FEED PLATENS

Form Width in Inches	Maximum Characters* Per Line	Form Width in Inches	Maximum Characters* Per Line
9	77	5-3/4	44
8-1/2	72	5-1/2	42
8	67	5	37
7-1/2	62	4-1/2	32
7	57	4-5/16	30
6-1/2	52	4-1/4	29
6-3/8	51	4	27
6-1/4	50	3-5/8	23
6	47		

\* Based on ten characters per inch with allowance of three characters for platen endplay.

**TYPING UNIT RIBBON**

Style . . . . . Black record ribbon  
 Length . . . . . 33 feet  
 Width . . . . . 1/2 inch  
 Thickness . . . . . 0.0055 inch

**TAPE SPECIFICATIONS**

Type . . . . . Standard communications  
 Width . . . . . 11/16 inch  
 Code perforations. Chadless or fully perforated  
 Characters or feed holes per inch . . . . . 10

**TYPING UNIT PAPER (FRICTION FEED)**

Type . . . . . Standard yellow paper roll  
 Outside diameter . . . . . 4-1/2 inch  
 Width . . . . . 8.45 inch  
 Length . . . . . 325 feet  
 Core diameter . . . . . 1 inch  
 Core thickness . . . . . 0.125 inch

**PRINTED CHARACTERS (TAPE)**

Height . . . . . Chadless, 0.120 inch;  
 fully perforated, 0.100 inch  
 Width . . . . . Chadless, 0.075 inch;  
 fully perforated, 0.046 inch  
 Location of Printing . . . . . Along upper edge of  
 chadless perforated tape;  
 between feed holes on  
 fully perforated tape

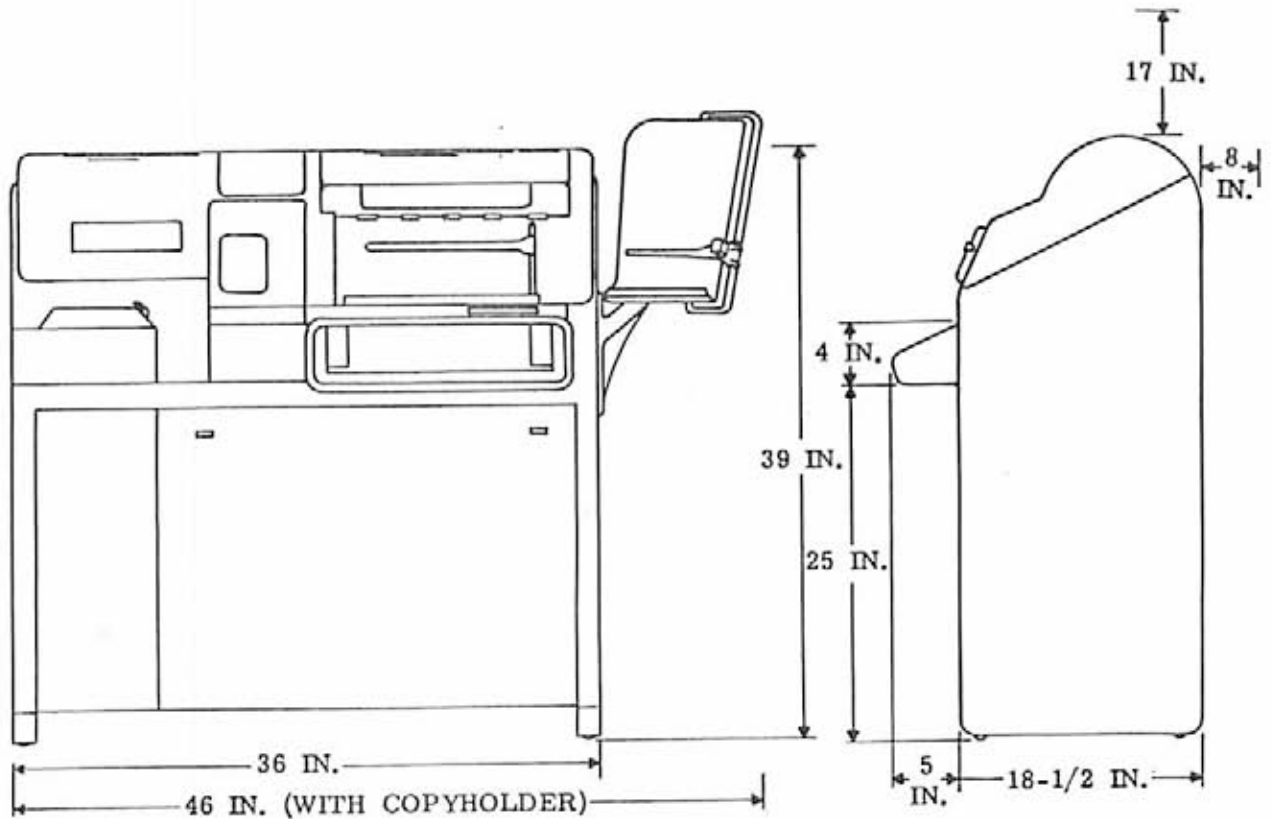

Figure 4 - ASR Set Dimensions

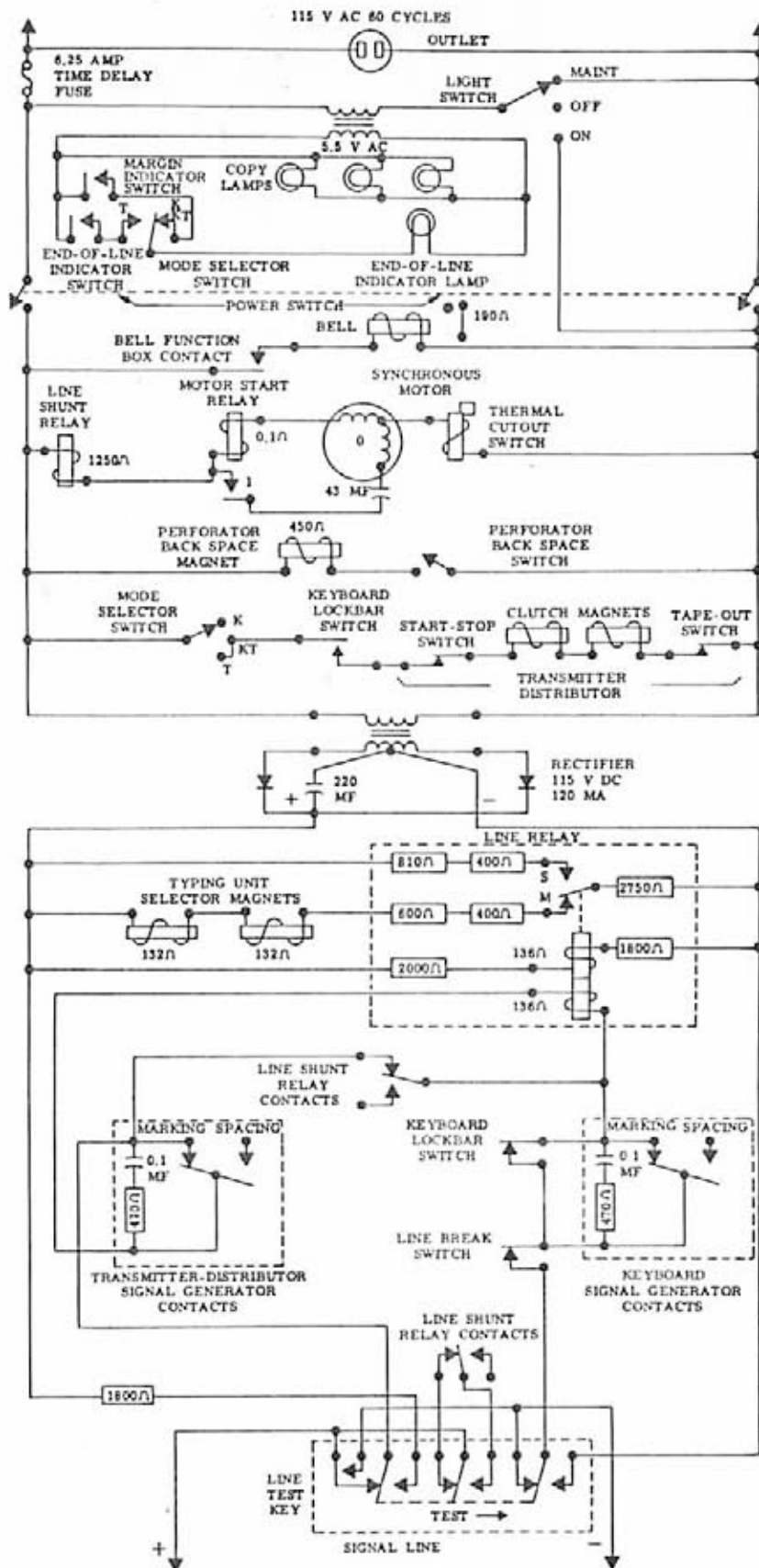

Figure 5 - Typical 28 Automatic Send-Receive (ASR) Teletypewriter Set, Schematic Diagram



28 PERFORATOR-TRANSMITTER BASE

DESCRIPTION AND PRINCIPLES OF OPERATION

CONTENTS	PAGE	CONTENTS	PAGE
1. GENERAL . . . . .	1	4. VARIABLE . . . . .	23
2. DESCRIPTION OF COMPONENTS . . .	2	ANSWER-BACK MECHANISM. . . . .	23
BASE . . . . .	2	A. Called Station . . . . .	23
KEYBOARD ASSEMBLY . . . . .	2	B. Originating Station . . . . .	25
SIGNAL GENERATOR . . . . .	3	SYNCHRONOUS PULSED TRANSMISSION . . . . .	26
RESET CAM FOLLOWER BRACKET ASSEMBLY . . . . .	3	TIME DELAY MECHANISM . . . . .	26
CODEBAR EXTENSION BASKET ASSEMBLY. . . . .	4	1. GENERAL	
3. PRINCIPLES OF OPERATION . . . . .	4	1.01 This section is issued as a standard publication to cover the description and principles of operation for the 28 perforator- transmitter base.	
KEYBOARD MECHANISM . . . . .	4	1.02 The 28 perforator-transmitter base is an electromechanical unit which provides means for transmitting coded electrical impulses to a signal line and/or means for mechanically operating any one of four associated perforators --- a nontyping perforator, a typing perforator, a nontyping reperforator, or a typing reperforator. It also serves as a base mounting for an associated page typing unit for monitoring the message being transmitted from the keyboard.	
A. General . . . . .	4	1.03 A mode selecting mechanism is provided for switching the unit into any one of three positions (K, K-T, and T) to perform the following functions:	
B. Codebar . . . . .	4	(a) Direct keyboard transmission to a signal line with monitoring of the message by a page typing unit (K position).	
C. Signal Generator . . . . .	6	(b) Direct keyboard transmission and si- multaneous operation of a perforator or reperforator with monitoring of a message by a typing unit (K-T position).	
D. Repeat Keylever. . . . .	9		
E. Electrical Line Break . . . . .	10		
F. Local Line Feed. . . . .	10		
G. Local Paper Feed-Out. . . . .	11		
H. Electrical Keyboard Lock . . . . .	12		
I. Keyboard Unlock (Send Key). . . . .	12		
J. Local Carriage Return . . . . .	15		
K. Margin Indicator . . . . .	15		
L. Character Counter . . . . .	18		
M. Auxiliary Electric Switch. . . . .	18		
N. Tape Supply Container. . . . .	18		
O. Keyboard Tape Backspace . . . . .	18		
KEYBOARD PERFORATOR LINK- AGE MECHANISM . . . . .	19		
A. General . . . . .	19		
B. Operation in K Position . . . . .	19		
C. Operation in K-T Position . . . . .	20		
D. Operation in T Position. . . . .	22		

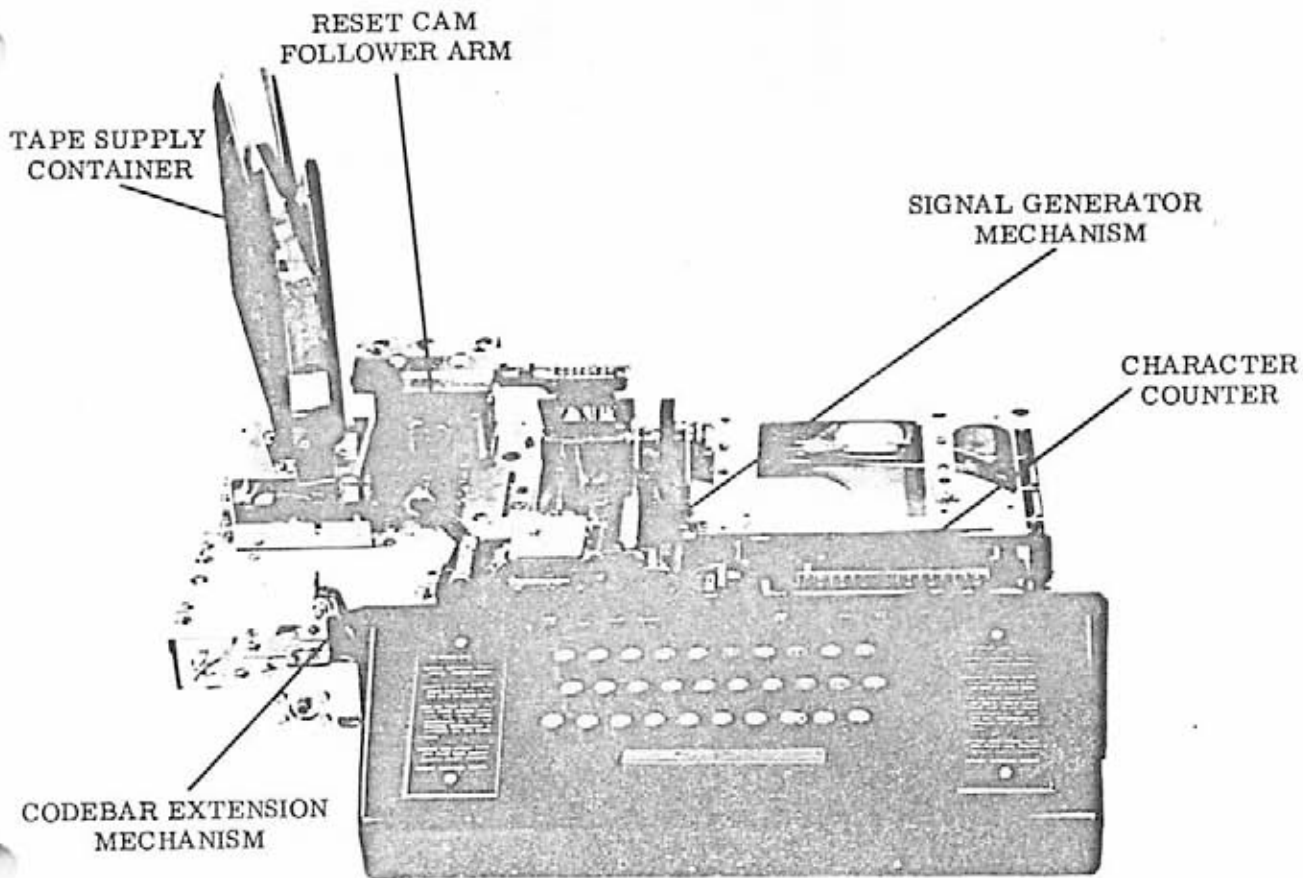

Figure 1 - 28 Perforator-Transmitter Base

(c) Operation of a perforator or reperforator only (T position).

1.04 With direct keyboard transmission, linkage to the perforating mechanism is depressed to disassociate the punching mechanism from the keyboard operation. Under this condition, if a typing or nontyping reperforator is being used, circuitry can be established to permit the reperforator to receive incoming traffic from a second line circuit.

1.05 Several variable features, such as a character counter, electrical keyboard lock, code reading contacts, timing contacts, signal line break, tape backspace, paper feed-out, and motor start are available as optional features.

1.06 Maximum keyboard speeds are 368, 460 and 600 operations per minute (opm) in the K and K-T positions. In the T position, maximum speed is 900 opm. These speeds are for a 5-unit start-stop code (7.42 unit).

Note: In the illustrative drawings, fixed pivot points are indicated as solid black circles. Movable pivot points are indicated as cross-hatched circles.

## 2. DESCRIPTION OF COMPONENTS

### BASE (Figure 1)

2.01 The base is a reinforced aluminum sheet metal box frame on which all other assemblies are mounted.

### KEYBOARD ASSEMBLY (Figure 2)

2.02 The keyboard assembly consists of a keylever guide assembly, front frame, guideplate, keylevers, and ball lock assembly.

2.03 The keylever guide assembly accommodates all code and function levers.

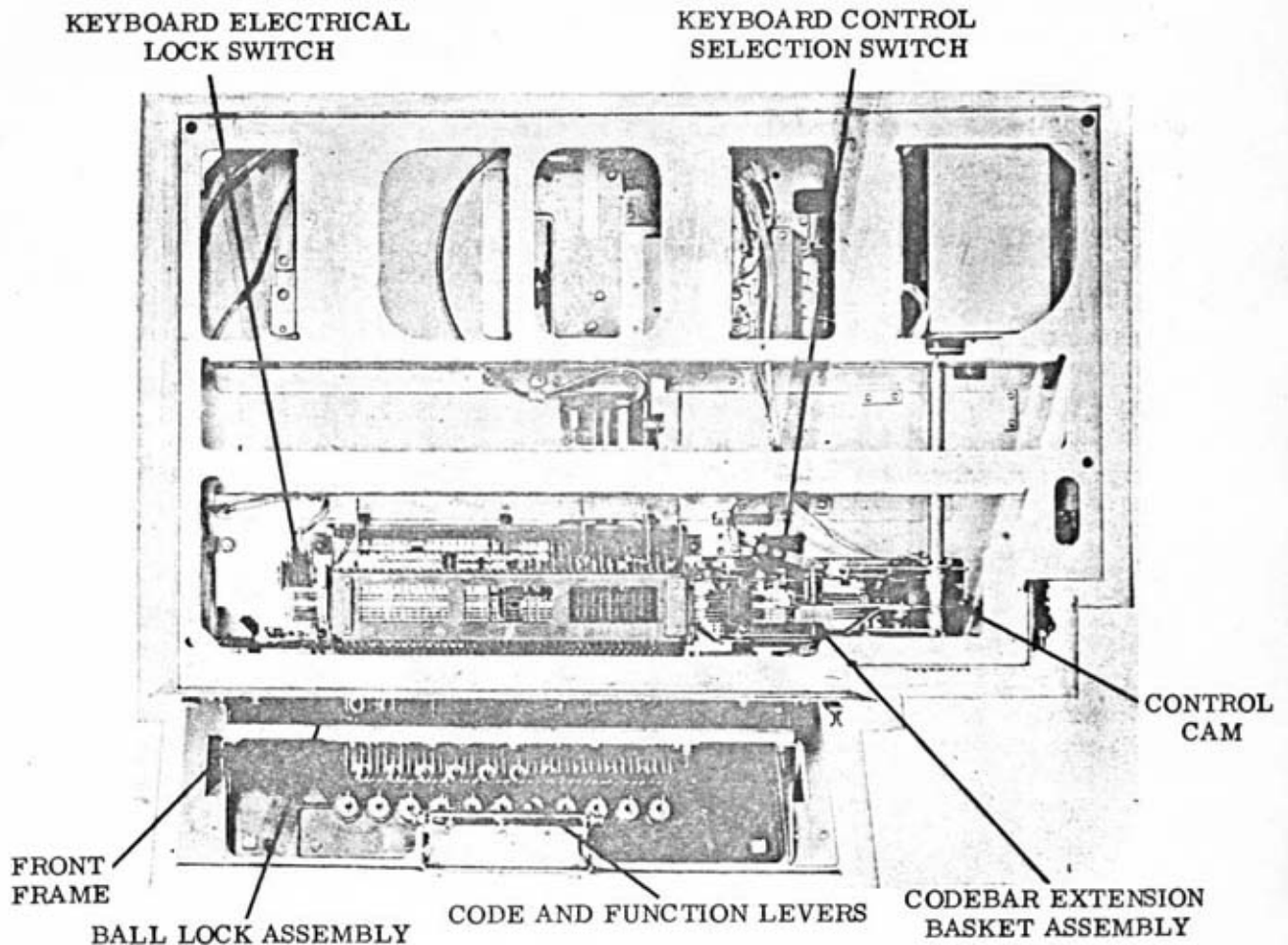

Figure 2 - Perforator-Transmitter Base (Bottom View)

#### SIGNAL GENERATOR (Figures 2 and 7)

2.04 The signal generator consists of a frame assembly; front and rear plate assemblies; gear, shaft, clutch and cam assembly; and a contact box assembly.

2.05 The clutch stop levers and latchlever are mounted on the frame. The codebar assembly and nonrepeat lever with its guide are mounted on the rear plate. The front plate acts as a mount for the detent plate assembly; transfer bail and stud; transfer levers with their guides springs, and mounting studs; and the locking bail with its stud and spring.

2.06 The cam, clutch, and shaft assembly is mounted between the front and rear plates. The cam is one piece of machined steel with eight lobes. The seven lobes which generate pulse signals, are equal in contour and are positioned at uniform angles with one another. The eighth lobe differs in contour, and is used to actuate the transfer lever locking bail.

2.07 The universal bail latchlever with its eccentric bushing is fastened to the right front of the frame. This latchlever extends to the rear over the codebar bail latch and the non-repeat lever pawl.

2.08 The contact box assembly is mounted on the front plate. It is composed of a fiber insulating strip, a contact toggle assembly and phenolic base, drive link, and an arc suppressor, or RF filter.

#### RESET CAM FOLLOWER BRACKET ASSEMBLY (Figure 1)

2.09 This assembly consists of a hollow shaft with internal oilite bearings pivoting on a fixed shaft. A hooked arm on one end of the hollow shaft connects the hollow shaft to the clutch-tripbar assembly. An adjustable arm and roller on the other end of the hollow shaft follows the reset cam on the perforator main shaft.

2.10 The entire assembly provides linkage between the clutch tripbar and the cam on the associated perforator when the mode selector is in T position, thereby permitting the keyboard to be reset at high speeds.

#### CODEBAR EXTENSION BASKET ASSEMBLY (Figure 2)

2.11 This assembly consists of the following major components:

- (a) The codebar extensions which are used to transmit character information from the keyboard to the punch.
- (b) The clutch tripbar extension which links the clutch tripbar to the perforator clutch trip lever extension in K-T and T positions.
- (c) The codebar extension blocking bail, which blocks the selection of codebar extensions and character counter codebars in the K position. It also prevents the perforator clutch from being tripped in K position.
- (d) The selector lever assembly, which permits the signal generator clutch to be tripped in K and K-T positions. It also prevents the signal generator from being tripped in T position.
- (e) The control cam, which drives the auxiliary electric switch and provides the K, K-T, and T operations of the perforator transmitter.

2.12 The primary purpose of the codebar extension basket assembly is to transmit character information from the keyboard codebars to a perforator, and to serve as control center for the various functions of the 28 perforator-transmitter base.

### 3. PRINCIPLES OF OPERATION

Note: Inasmuch as the mechanical operation of the perforator-transmitter and its associated perforator or reperforator are so closely related — one depending on the other functionally — it will be necessary in presenting the principles of operation to overlap certain mechanical actions within the two units for clarity.

## KEYBOARD MECHANISMS

### A. General

3.01 The keyboard mechanism and optional features are mounted on the base. These mechanisms include the intermediate gear, codebar mechanism with keylevers, signal generator mechanism, various function mechanisms and a character counter mechanism. Necessary circuits are brought out to a connector mounted at the left rear of the base. The signal generator shaft, through a helical gear on the rear of the shaft, is operated by the main shaft of the typing unit which, in turn, derives its power from a motor unit.

### B. Codebar

3.02 The codebar mechanism is located on the front underside portion of the keyboard. Each keylever in the lower three rows and the spacebar is connected to a code lever and each keylever in the upper row is connected to a function lever.

3.03 The code and function levers pivot about points near their midportions (Figure 3). Located above the rear half of the code levers and running parallel with the keyboard are, from rear to front, the clutch tripbar, the numbers 1, 2, 3, 4 and 5 codebars, two character counter bars (counter and carriage return), and the lockbar. The rear portion of each code lever or function lever is normally held downward by a spring so that the front end, with its attached keylever, is held upward.

3.04 A wedgelock is mounted on the projection of the lower front portion of all code levers (Figure 4). If one of these levers is operated, its wedgelock moves downward between the lock balls in the lock ball channel and crowds them together. This prevents any other lever with a wedgelock from being operated at the same time.

3.05 With the signal generator shaft in its stop position, the codebars and clutch bar are held toward the left (viewed from the front) against the tension of their springs by the latched-up codebar bail.

3.06 When any keylever in the three lower rows or the spacebar is depressed, the rear end of the associated code lever engages and rotates the code lever universal bail counter-clockwise (Figure 3). The extension on the code lever universal bail disengages from the step at the rear of the universal bail latchlever. This lever then moves downward under the tension of its spring. As the lever falls, it strikes the codebar bail latch and carries it downward (Figure 5). When the corner of the codebar bail latch falls beyond the centerline of the needle bearing mounted on the codebar bail, the codebar bail is released and swings to the right.

3.07 Upon being freed, the codebar bail, the clutch tripbar, and the selected codebars are pulled to the right by their springs. Unselected codebars are stopped from moving to the right by the operated keylever or spacebar. For example, if the L lever is depressed, codebars 1, 3 and 4 will be stopped by the code lever engaging teeth on the underside of the codebars.

The teeth on codebars 2 and 5 are omitted in this area and the bars are permitted to move to their extreme right-hand position (Figure 6).

3.08 The codebars have vertical extensions that engage a curved part of the signal generator transfer levers (Figure 7). The codebars which are permitted to move to the right carry with them their respective transfer levers.

3.09 Simultaneously with the above operation, the clutch tripbar moves to the right. A keyboard control selection lever (Figure 21) is linked to and moves to the right with the clutch tripbar. When the three-position keyboard control knob is in the K or K-T position (Paragraph 3.42), a projection on the keyboard control selection lever trips the signal generator clutch stop lever. The clutch then engages and rotates the signal generator cam.

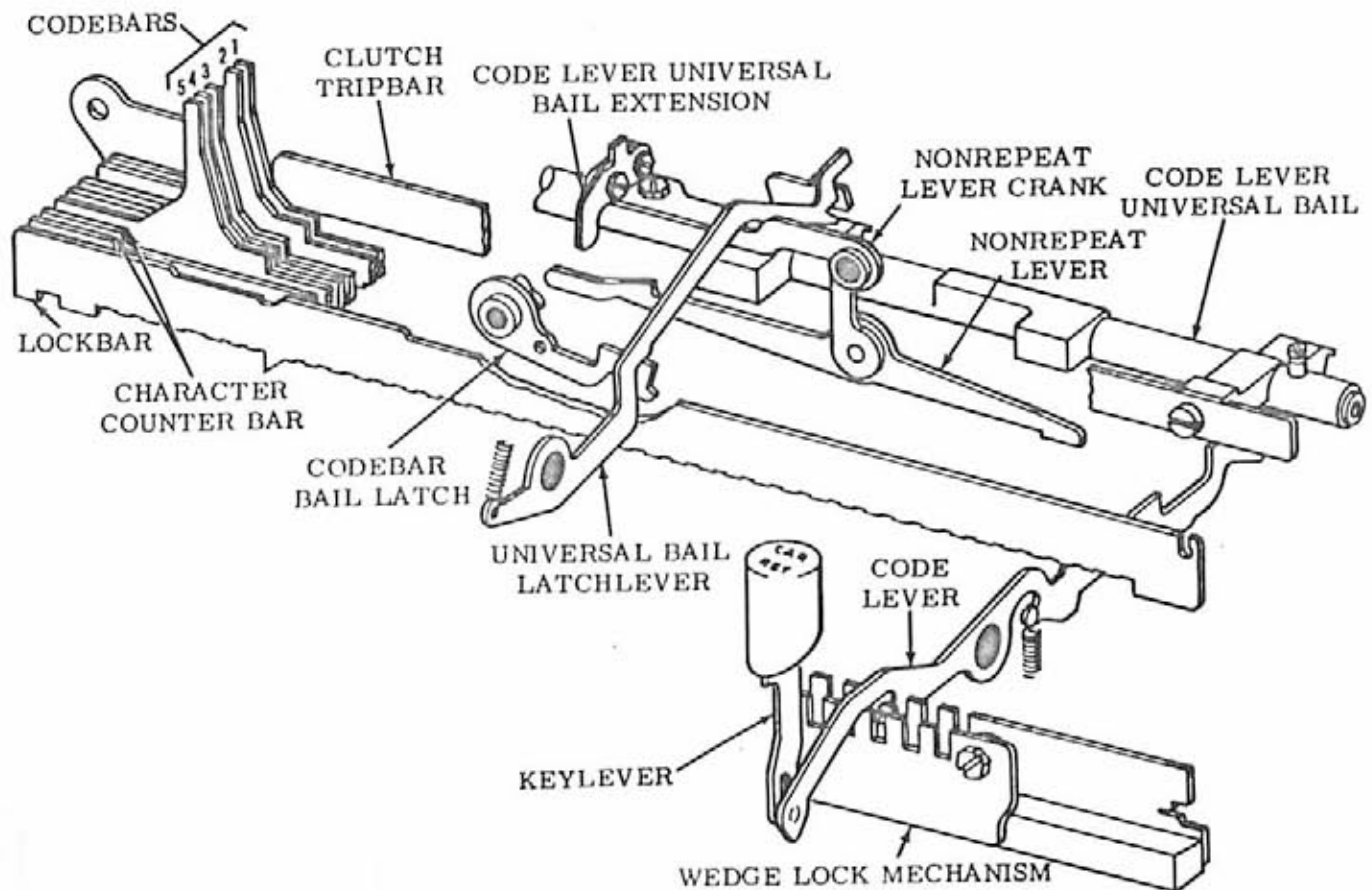

Figure 3 - Codebar and Code Lever Universal Bail Mechanism

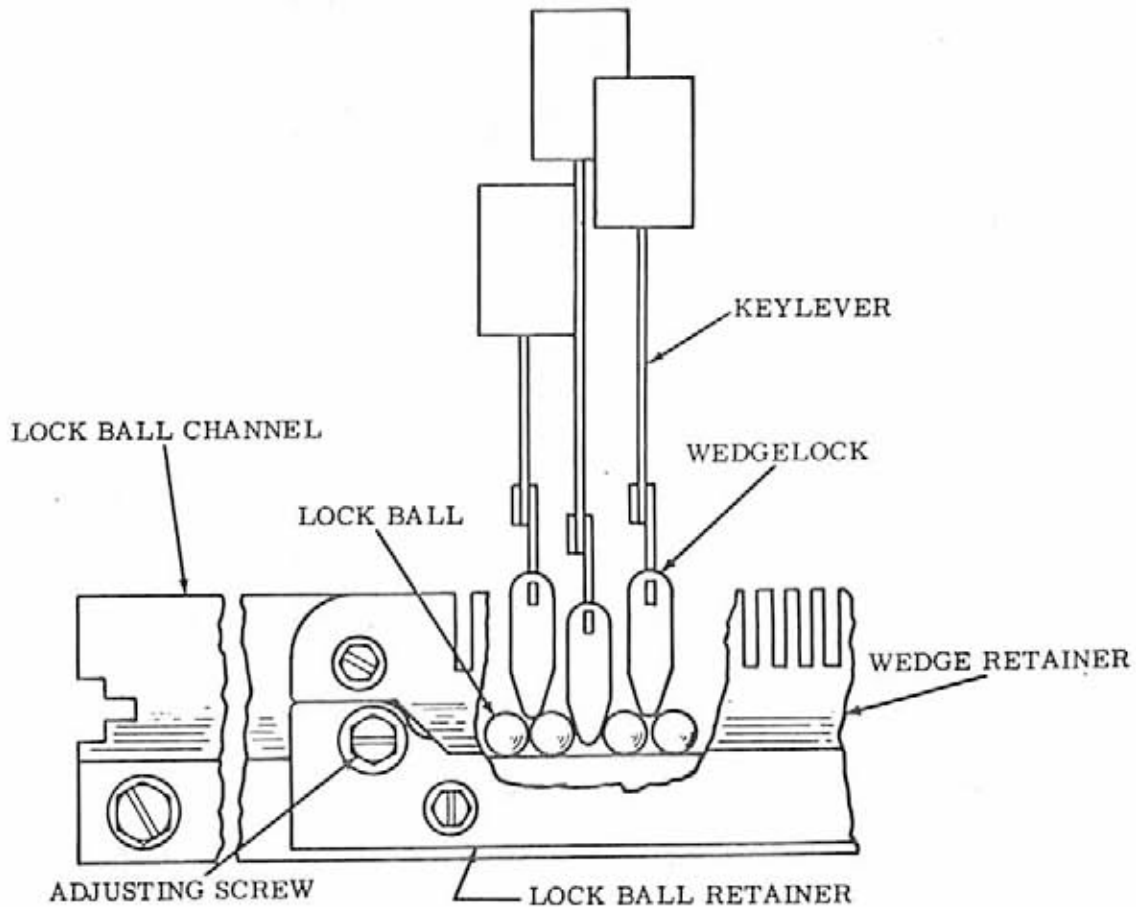

Figure 4 - Wedgeloek Mechanism

3.10 Operation to this point is manual, resulting only from depressing a code lever or spacebar. The remainder of the operating cycle is covered in Paragraph C. below.

#### C. Signal Generator

3.11 When the clutch stop lever is tripped (Paragraph 3.09), the clutch shoes engage a serrated surface on the inside of the clutch drum. When power is on (motor unit operating), the clutch drum rotates continuously in a clockwise direction (viewed from the front) because it is a part of the geared signal generator shaft. Since the clutch shoes are mounted on a plate that is part of the cam assembly, the cam rotates upon engagement of the clutch.

3.12 As was shown in Paragraph 3.08, each of the five codebars operates its own transfer lever (Figure 7). In addition to these five transfer levers, there are two others which are not associated with codebars. These are used to originate the start and stop pulses.

3.13 The cam lobes are numbered from 1 to 8 from rear to front. There are seven signal-pulse lobes on the cam (one for each transfer lever). The eighth cam lobe is used to actuate the locking bail.

3.14 The cam lobes are arranged so that when the cam rotates, lobe 3 engages its transfer lever first and moves it downward. Almost at the same time, the eighth lobe from the rear begins to move the locking bail upward. A blade on the locking bail engages in slots on the selected transfer levers and locks them in position. Unselected transfer levers are locked in the left position as the blade blocks their movement. Thus, in the first few degrees of cam rotation, the permuted position of the transfer lever is locked and the codebars are free to be reset in their normal latched positions.

3.15 Transfer lever 3 is the start pulse transfer lever. There is no codebar to engage this lever, hence it is always held to the left by

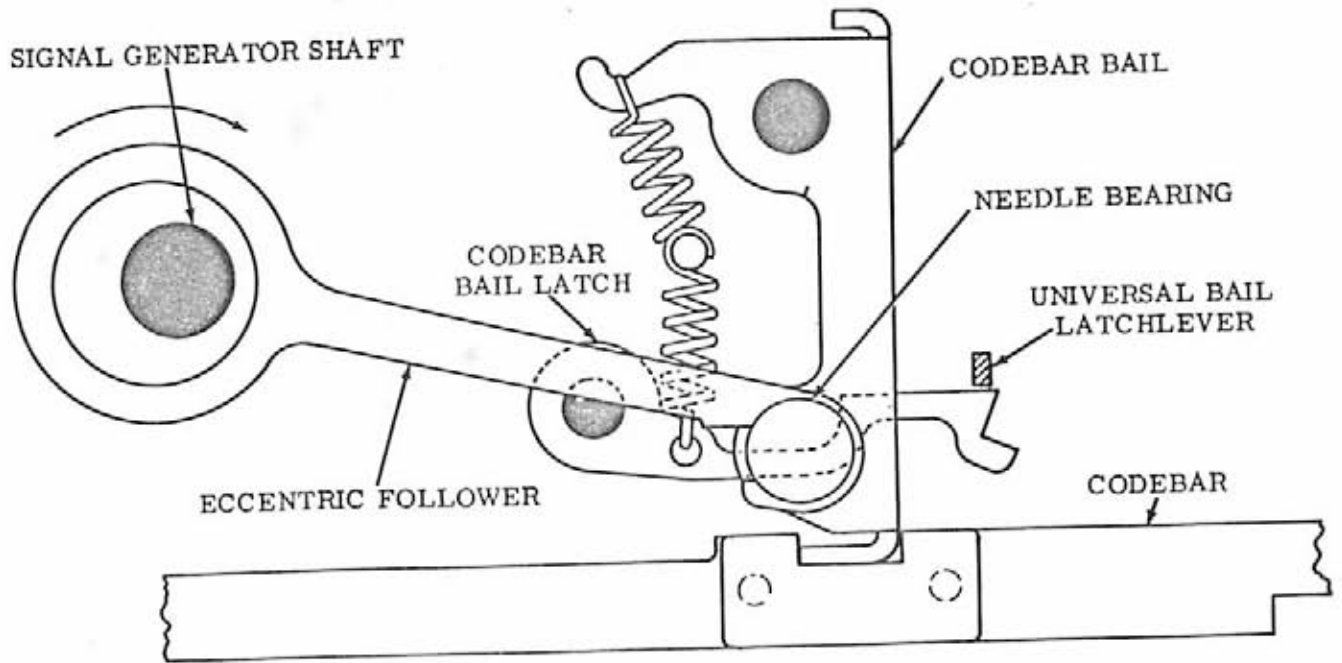

Figure 5 - Codebar Bail Mechanism

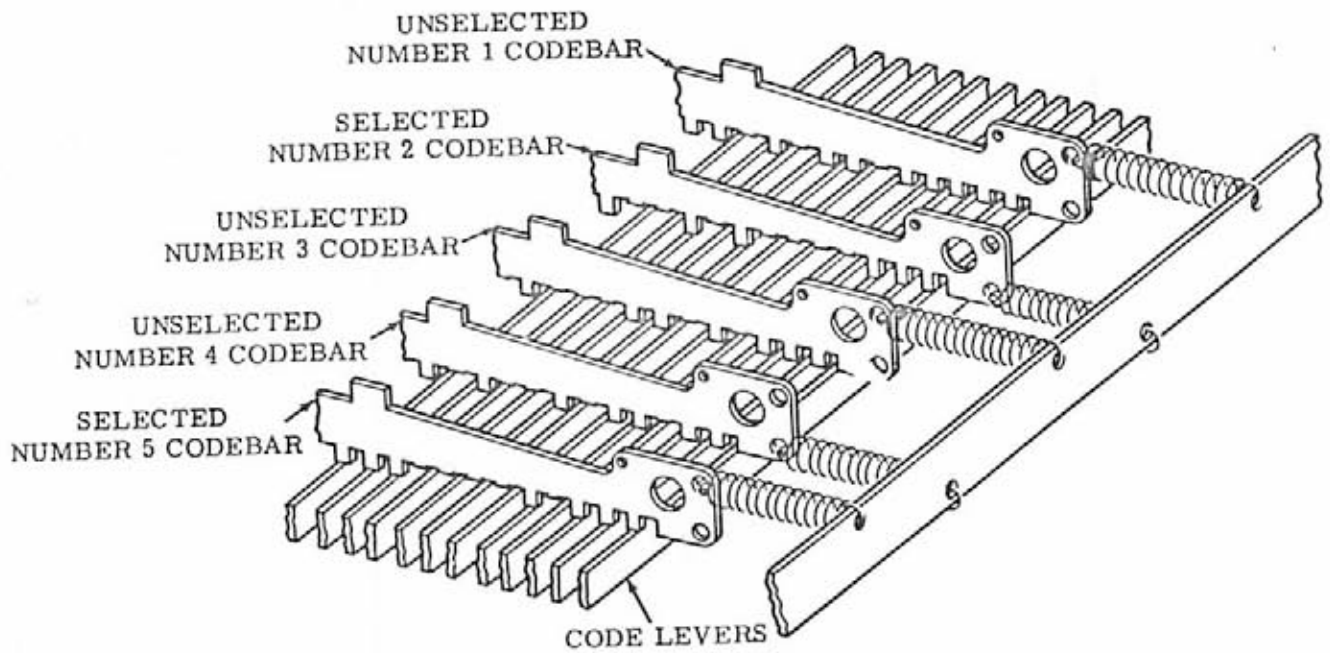

Figure 6 - Codebar Selection

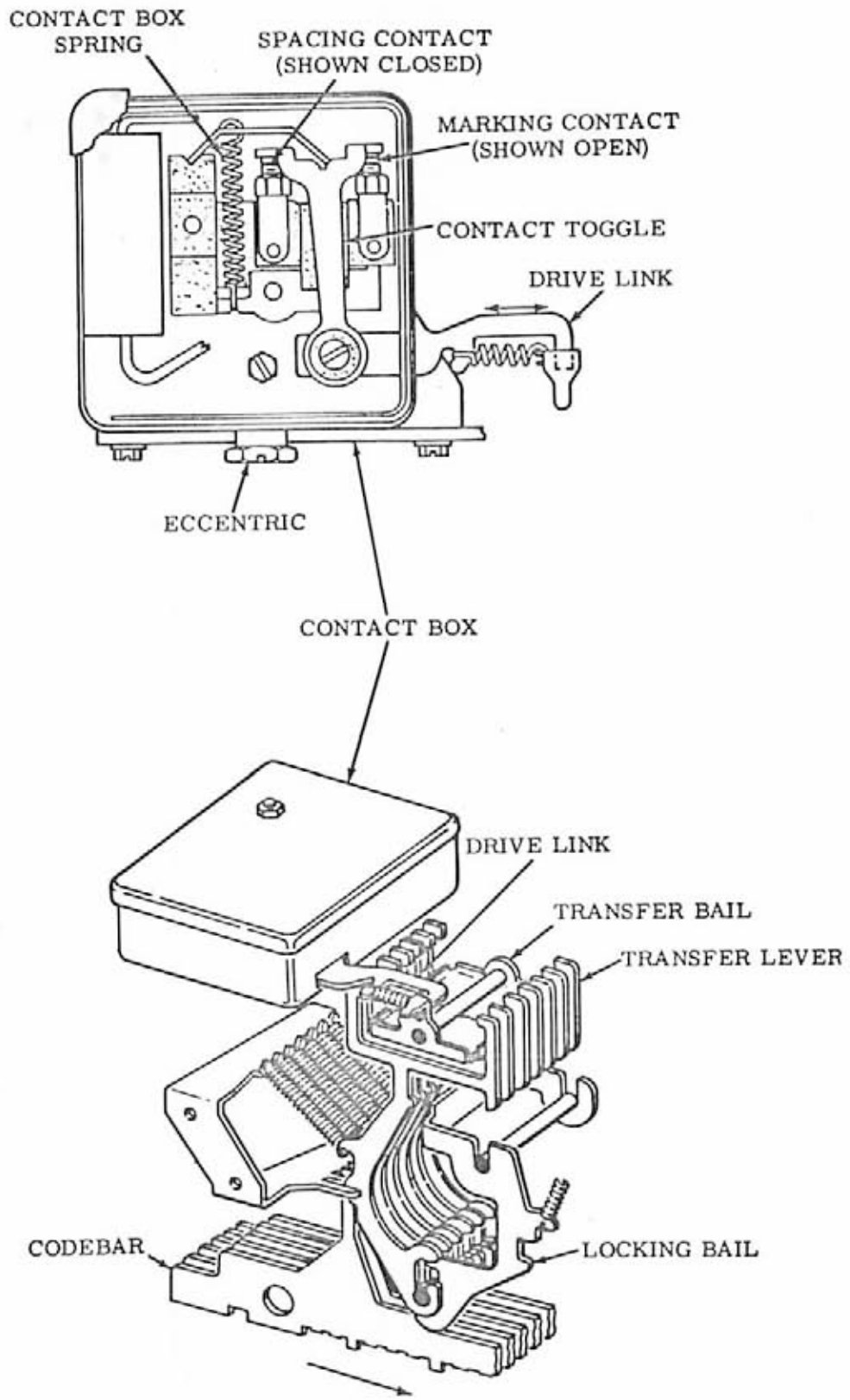

Figure 7 - Transfer Lever and Contact Box Mechanisms



its spring. As cam lobe 3 moves this lever down, the hook on the upper right of the lever engages the right-hand side of the transfer bail. This trips the transfer bail to the right and pulls the contact drive link (Figure 7) to the right. The resulting action of the contact toggle is such that the marking contacts open and the spacing contacts close. Under this condition there is "no current" in the signal circuit. This is known as a spacing pulse. Thus, the first pulse (or start pulse) of any character is a spacing (no current) pulse.

3.16 Lobe 1 and its transfer lever move downward next. For the character L it has been shown (Paragraph 3.07) that transfer lever 1 is positioned to the right. In turn, the upper left hook of this lever pulls downward on the transfer bail, tilting it back to the left. This pushes the drive link to the left, thereby closing the marking contacts and allowing a marking (current on) pulse to be transmitted.

3.17 Similarly, transfer levers 2, 4, 5, and 6 are pulled downward by their respective cam lobes. The resulting pulse will be marking if the transfer lever is to the right, or spacing if it is to the left.

3.18 Transfer lever 7 is the stop pulse transfer lever. This lever is permanently held to the right by a stop pin; therefore, the resulting pulse, the stop pulse, is always marking (current on).

3.19 The locking bail holds the transfer levers in their permutated positions until after the beginning of the fifth pulse. Then cam lobe

8 pulls the bail down out of locking position and all selected transfer levers are free to return to their left position.

3.20 Reset of the codebars is accomplished by means of an eccentric on the front of the cam, which drives an eccentric follower (Figure 5). The follower engages an eccentric stud on the side of the codebar bail and pulls the bail to the left as the cam rotates. As the codebar bail moves to the left, the codebar bail latch clears the needle bearing stud and is pulled upward into locking position under tension of the spring to latch or reset the codebar bail. As the codebar bail is moved into reset position, it engages projections on the permutated codebars, clutch tripbar, and a stop on the nonrepeat lever, thus moving all these elements to the left into latched reset position.

#### D. Repeat Keylever

3.21 Operation of the REPT keylever simultaneously with one of the keylevers in the three lower rows, or the spacebar, disables the nonrepeat mechanism and causes the character or function selected to be repeated as long as the REPT keylever is held operated. The operated REPT keylever causes its function lever to raise the right end of the nonrepeat lever (Figure 8) and rotates it about its pivot point. In this position, the nonrepeat lever cannot be engaged and operated by the codebar bail, therefore, the nonrepeat lever crank will not reset the operated codebar bail latch. The codebar bail and universal bail latch lever are thus maintained in their operated positions and the codebar bail follows the eccentric arm movement back and forth until the REPT keylever is released.

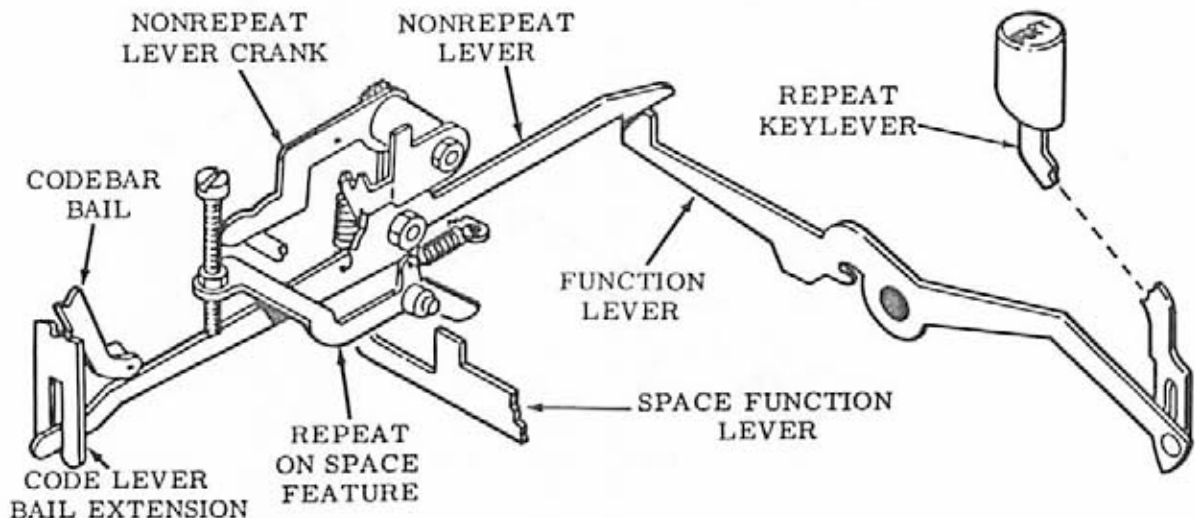

Figure 8 - Repeat Mechanism

## E. Electrical Line Break (Figure 9)

3.22 The electrical line break mechanism provides a means of interrupting signal line current for use as a break signal. Interruption of the line current is effected by depressing the BREAK keylever located on the keyboard.

3.23 When the BREAK keylever is depressed, its function lever pivots and raises the front end of the break lever. The rear portion of the break lever depresses the actuator pin of the sensitive switch, which opens the normally closed contacts. This action breaks the continuity of the signal line circuit, causing a break signal (no current) to be transmitted.

3.24 When the BREAK keylever is released, the tensions of the switch spring and break lever spring cause the function lever to return the keylever to its normal position and the switch contacts to their normally closed condition.

## F. Local Line Feed (Figure 10)

3.25 When the LOC LF keylever on the keyboard is depressed, paper is fed out of the associated typing unit when power is on. The

mechanism operates as follows: Depressing the LOC LF keylever raises the forward end of the local line feed bail. This bail pivots and its upper end pushes the attached local line feed trip link toward the rear until the link engages the line feed clutch trip lever on the typing unit. Thus, the line feed mechanism on the local typing unit is made to operate without a signal and other typing units on the same line circuit are not disturbed.

## G. Local Paper Feed-Out (Figure 11)

3.26 The local paper feed-out mechanism enables the operator to feed out copy paper by depressing the local line feed keylever, whether the printer set is on or off. The mechanism operates as follows:

- (a) Depressing the LOC LF keylever causes the local line feed trip link to move to the rear and unlatch the line feed clutch trip lever, as described in Paragraph F. above. If the set is operating, the result is that copy paper is fed out until the LOC LF keylever is released. If the set is not operating, the line feed clutch of the typing unit is conditioned to operate when the power is supplied.

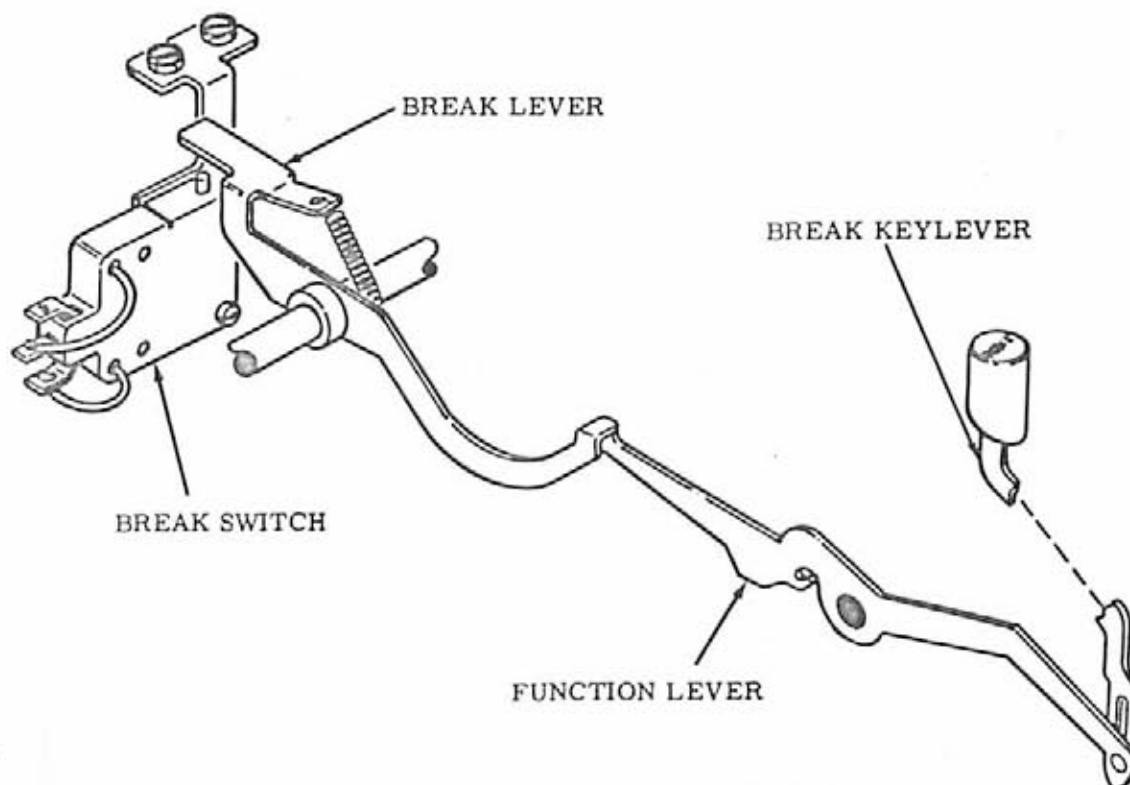

Figure 9 - Electrical Line Break Mechanism

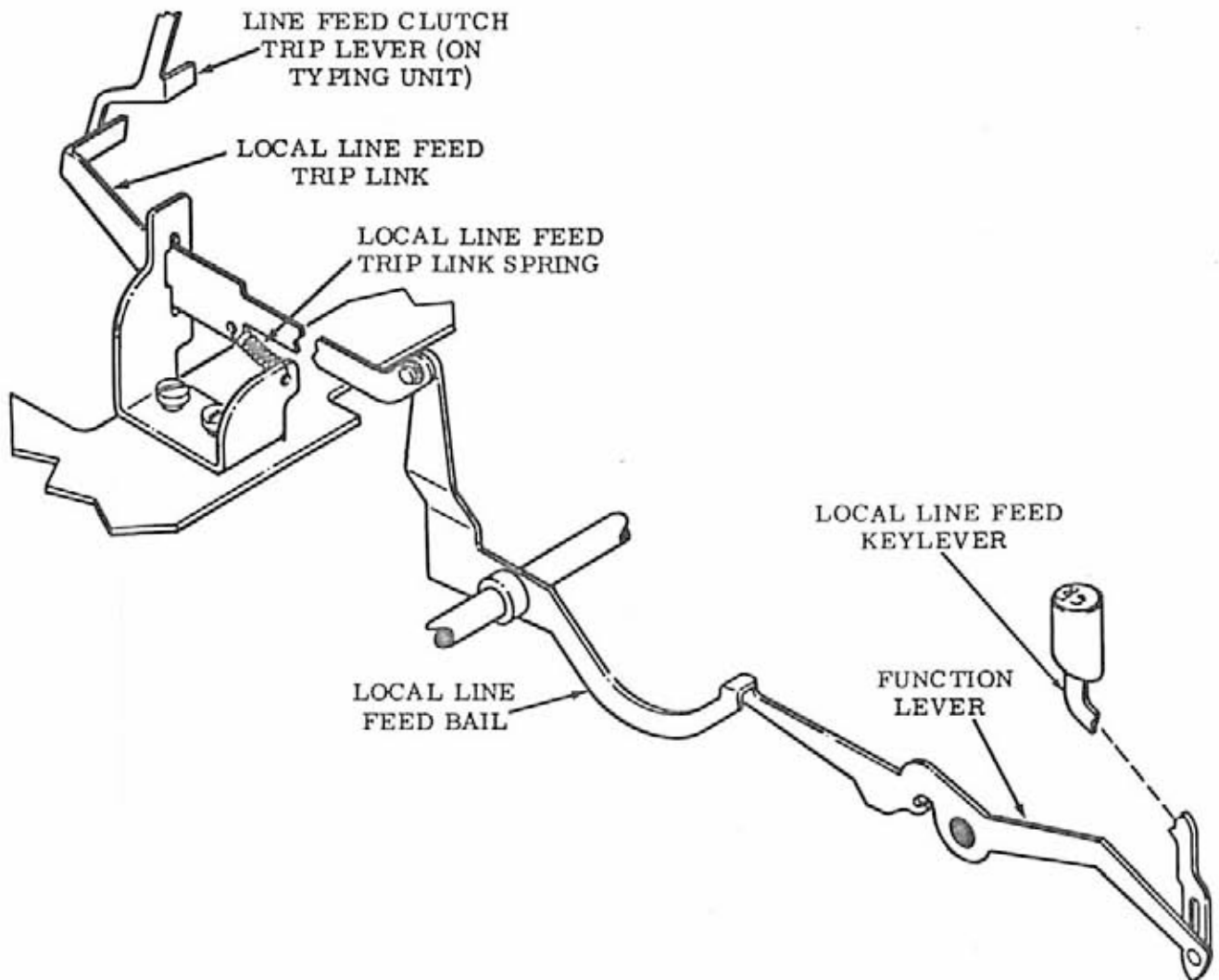

Figure 10 - Local Line Feed Mechanism

(b) When the local line feed trip link is fully actuated, it rotates the local paper feed-out switch lever, releasing the switch plunger and permitting the contacts in the magnetic blow-out switch to close.

(c) This actuates the motor circuit of the printer so that the motor will run and eject copy paper so long as the LOC LF key-lever is depressed (printer normally off).

#### H. Electrical Keyboard (Figure 12)

3.27 The electrical keyboard lock mechanism permits the signal generator contact to be electrically shunted from the keyboard or

from the associated typing unit shunt. This mechanism operates as follows:

(a) To shunt the keyboard locally, depress the REC keylever (Figure 12). This action raises the keyboard lock function lever which, in turn, raises the lockbar latch. With the lockbar latch disengaged, the lockbar is free to move to the right under spring tension of the keyboard lock switch contact on the switch lever. The switch lever then pivots, closing the contacts of the switch. The associated circuits are arranged to shunt the signal generator when the switch is closed. However, since there is no mechanical blocking of the keylevers, the perforator transmitter can still be operated as a tape perforator.

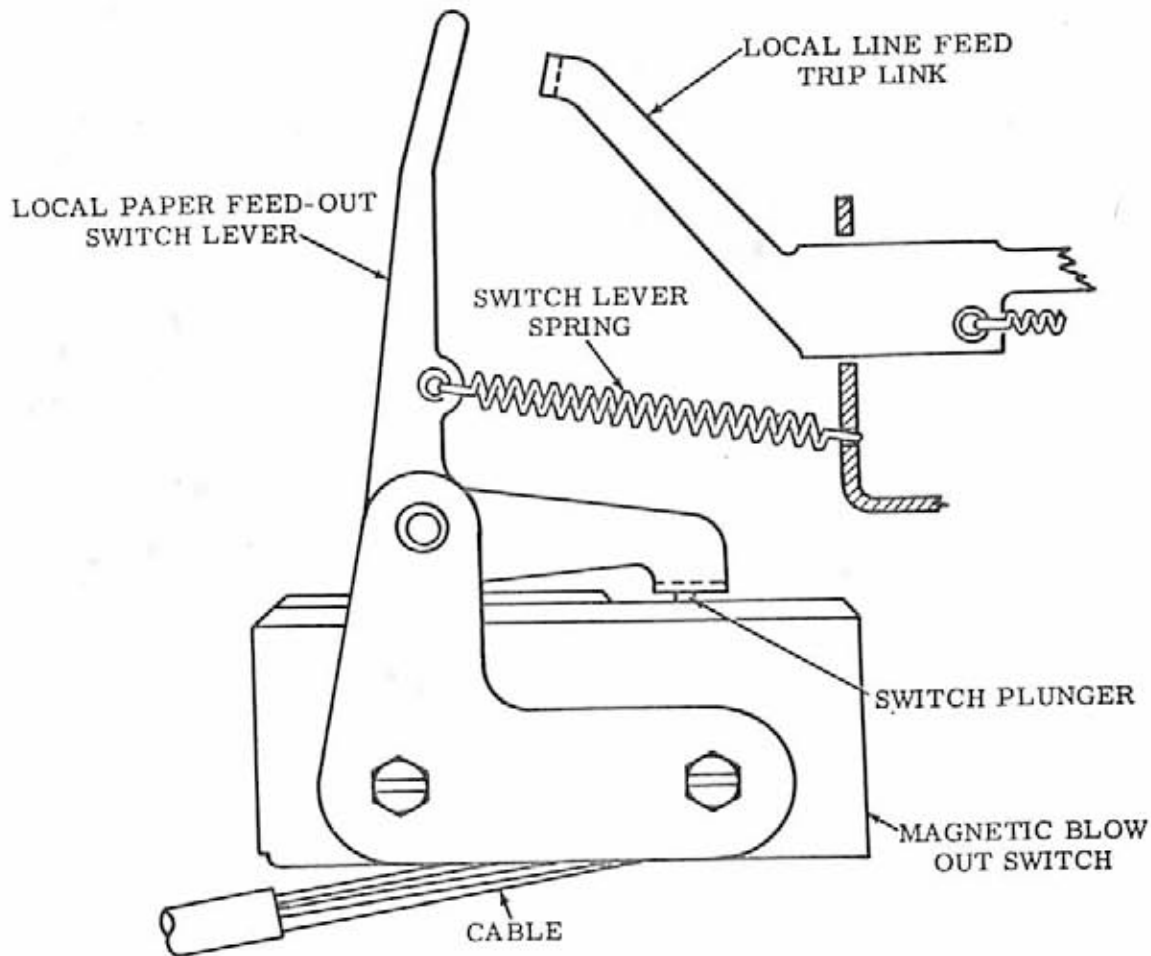

Figure 11 - Local Paper Feed-Out Mechanism

(b) The keyboard can also be shunted when two consecutive blank code signals are received by the associated typing unit. Under this condition, the keyboard locklever on the typing unit (Figure 12) moves downward and depresses the keyboard lock plunger. This movement causes the keyboard lock bail to pivot and raise the keyboard lock function lever. This disengages the lockbar latch and the keyboard is shunted as described in (a).

#### I. Keyboard Unlock (Send Key)

3.28 The keyboard unlock mechanism permits the keyboard to be unshunted. The operation of the mechanism is as follows:

(a) When the SEND keylever is depressed (Figure 13), the keyboard unlock function lever rises against a diagonal camming surface on the lockbar (Figure 12). This moves

the lockbar to the left until the lockbar latch falls into a notch on the lockbar.

(b) As the lockbar moves to the left, the switch lever (Figure 13) pivots and opens the contacts of the keyboard lock switch. The associated circuits are arranged so that, when the switch contacts open, the signal generator is no longer shunted (Paragraph 3.27) and normal signal transmission can take place.

#### J. Local Carriage Return

3.29 The local carriage return mechanism enables the operator to trip the carriage return mechanism on the associated typing unit, thereby causing the type box carriage to be fully returned to its normal position at the beginning of a line of copy. This mechanism operates as follows: When the LOC CR keylever (Figure 14) is depressed, its function lever rises and, in turn, raises the forward end of the local carriage

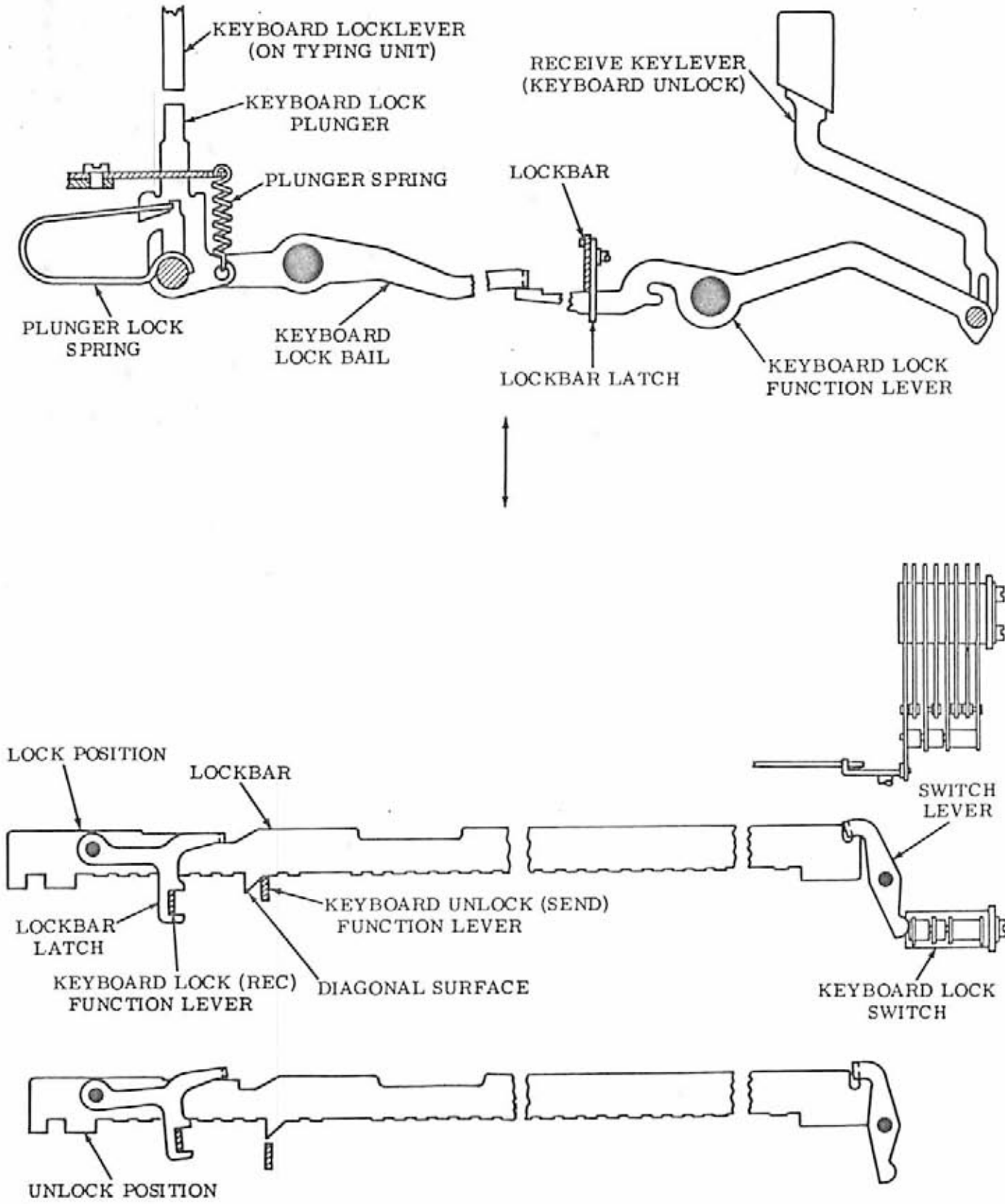

Figure 12 - Electrical Keyboard Lock Mechanism

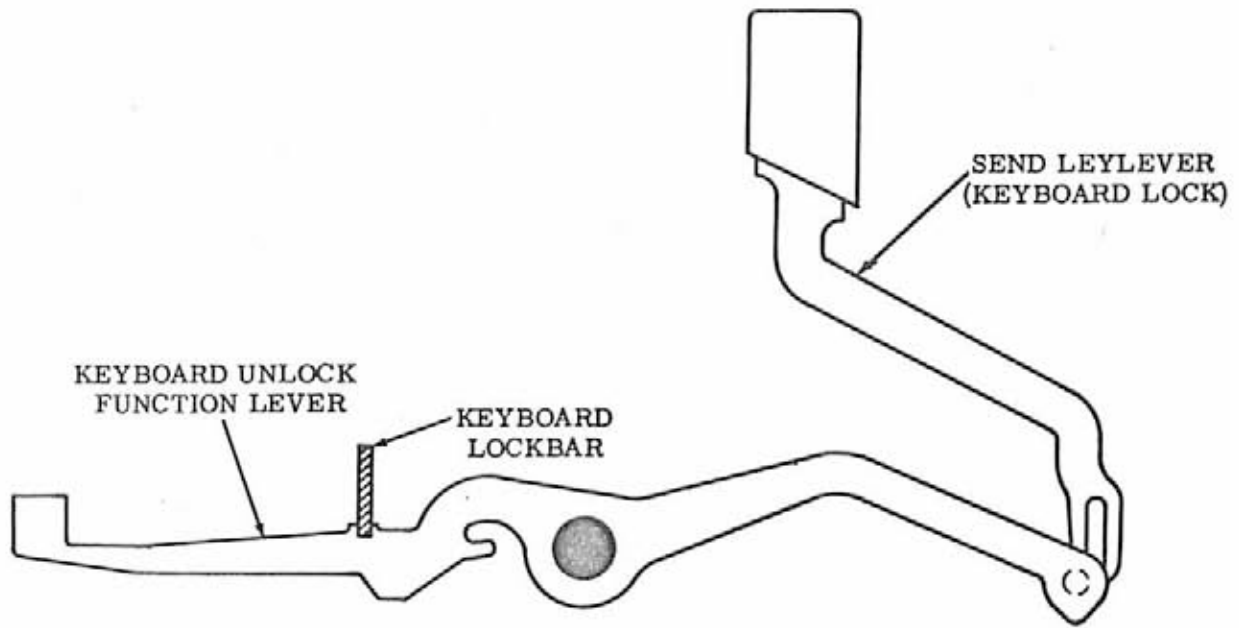

Figure 13 - Keyboard Unlock Mechanism

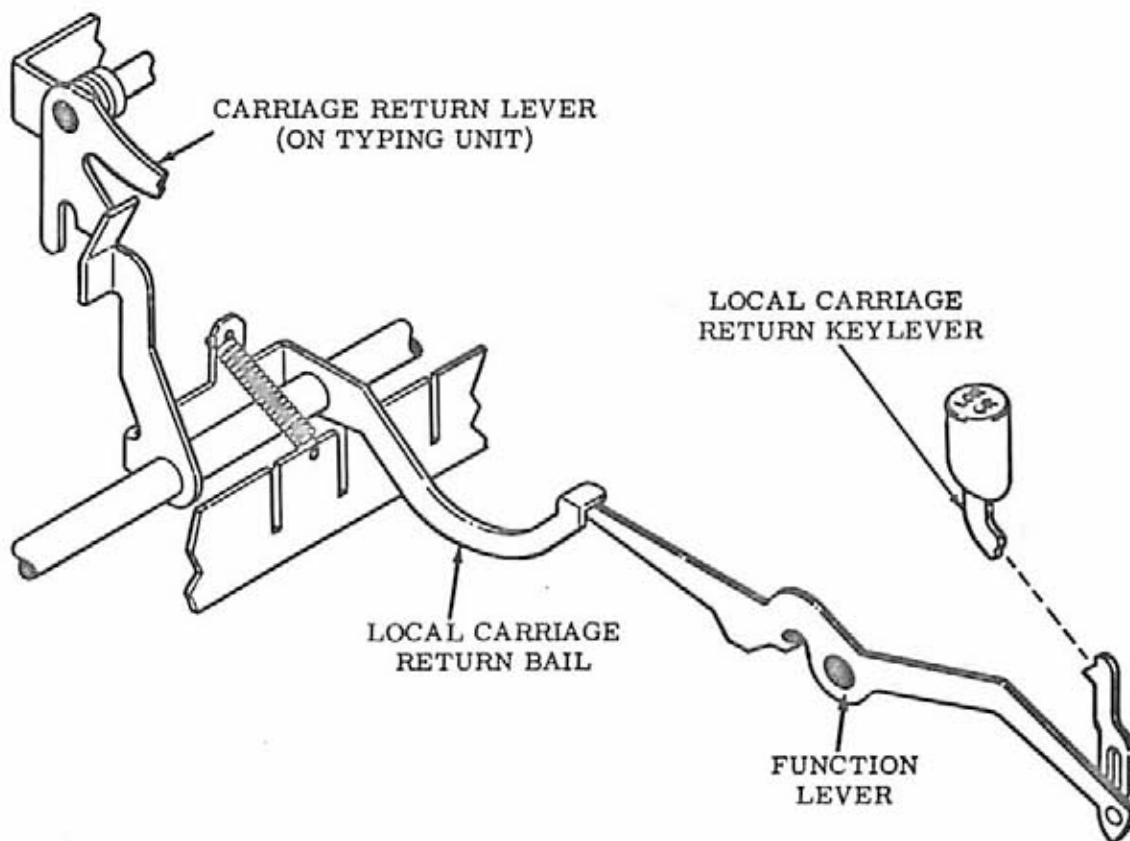

Figure 14 - Local Carriage Return Mechanism

return bail. This bail rotates about its pivot point until the upper end engages the carriage return lever on the typing unit. The carriage return mechanism operates in this manner without a signal that would cause other units in the line circuit to function.

#### K. Margin Indicator (Figure 15)

3.30 The margin indicator cam disc on the associated typing unit spring drum rotates with the drum as spacing occurs. As the end of each line is approached, the cam surface of the disc makes contact with the margin indicator contact switch lever and rotates it clockwise about its pivot point. When the lever rotates, it releases the margin indicator switch plunger. The normally open contacts are closed, completing the circuit to a margin indicator light in the cabinet. The carriage return cycle returns the cam disc to its starting position and the margin indicator switch opens. The switch is operative only when the keyboard is in the K and K-T positions.

#### L. Character Counter (Figures 16 and 17)

3.31 The character counter is driven mechanically from the perforator transmitter codebars located in the second and third slots of the codebar basket. These bars provide drive projections which engage the forks of the feed

and reset bails of the counter. As the codebars fall to the right when a key on the keyboard is struck, the counter mechanism is tripped. As the keyboard is reset under power, the counter performs its required functions. These functions may be divided into three distinct phases of operation. Figure 18 illustrates these three phases of operation, and also the normal position of the counter mechanism.

#### Stepping

3.32 Referring to sequence A, Figure 18, as a key is struck the codebars fall to the right, carrying with it feed bail 1. The drive lever, which is linked to the feed bail, moves to the left slightly more than one tooth. As the codebars are reset under power, stepping bail 1 moves clockwise, causing the drive lever to advance the ratchet drum one tooth. The drive pawl prevents the ratchet drum from rotating counterclockwise until it is again tripped for the following character. When this occurs, the ratchet drum rotates slightly counterclockwise, coming to rest against the latch lever.

#### Counter Reset

3.33 Sequence B, Figure 18, illustrates the tripped position of the counter mechanism for a reset function. Reset bail 2 moves counterclockwise as its codebar falls to the right, causing the reset lever in turn to rotate clockwise.

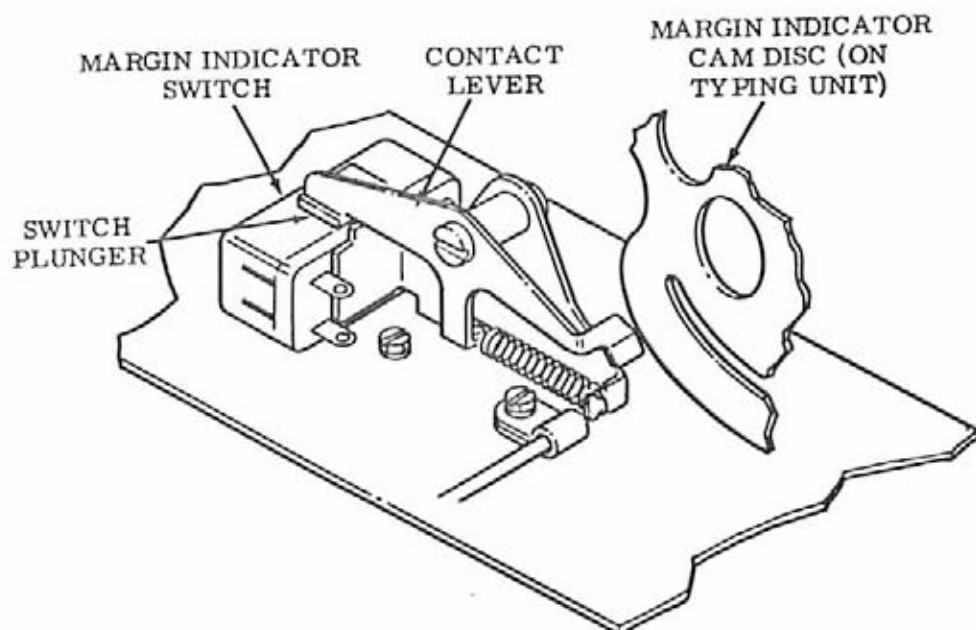

Figure 15 - Margin Indicator Mechanism

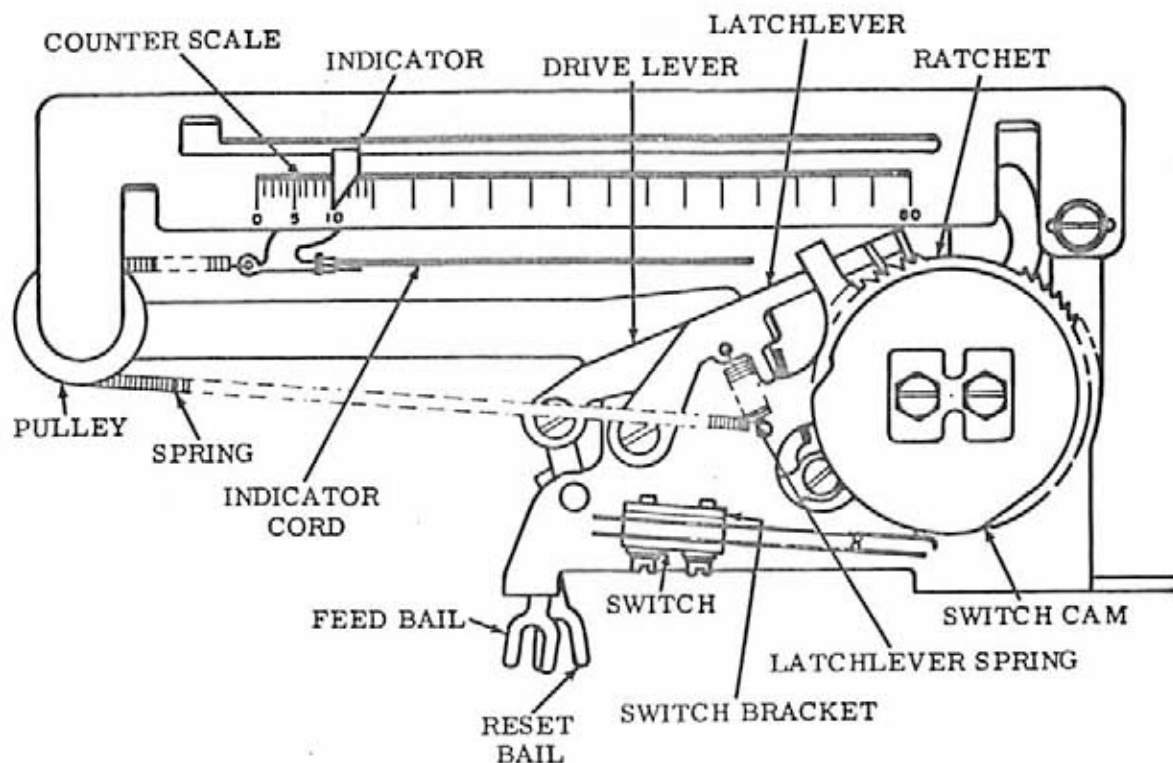

Figure 16 - Character Counter Mechanism (Front View)

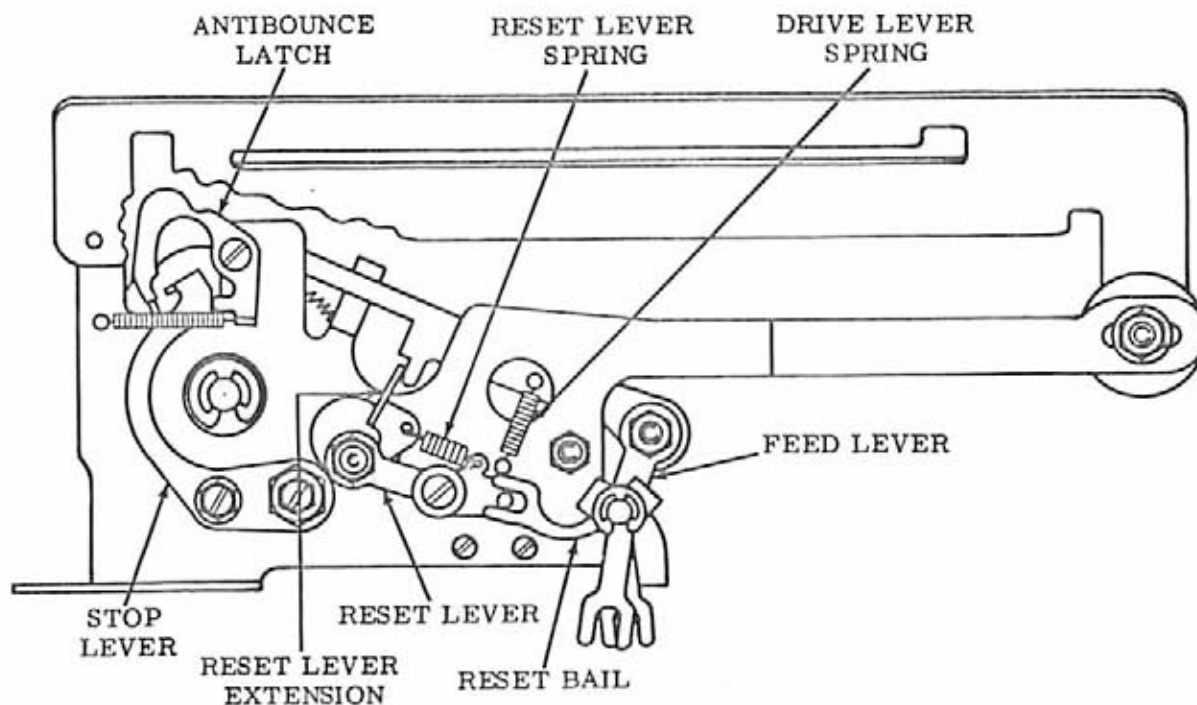

Figure 17 - Character Counter Mechanism (Rear View)



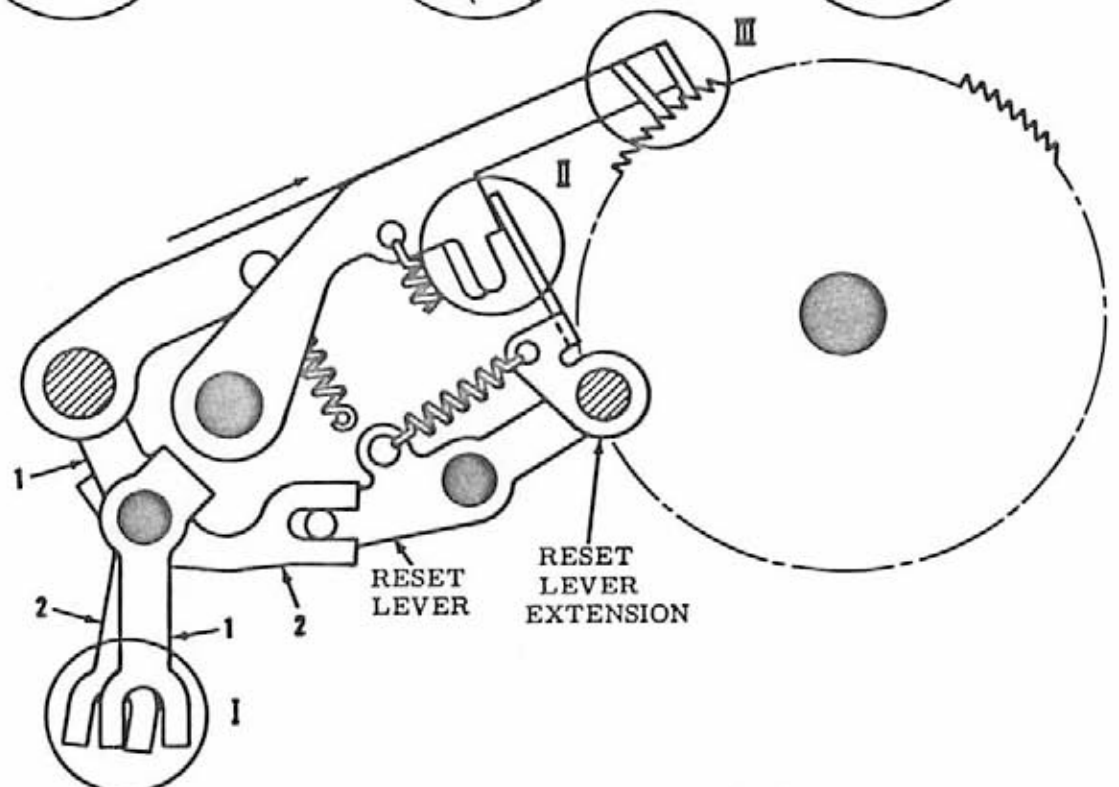
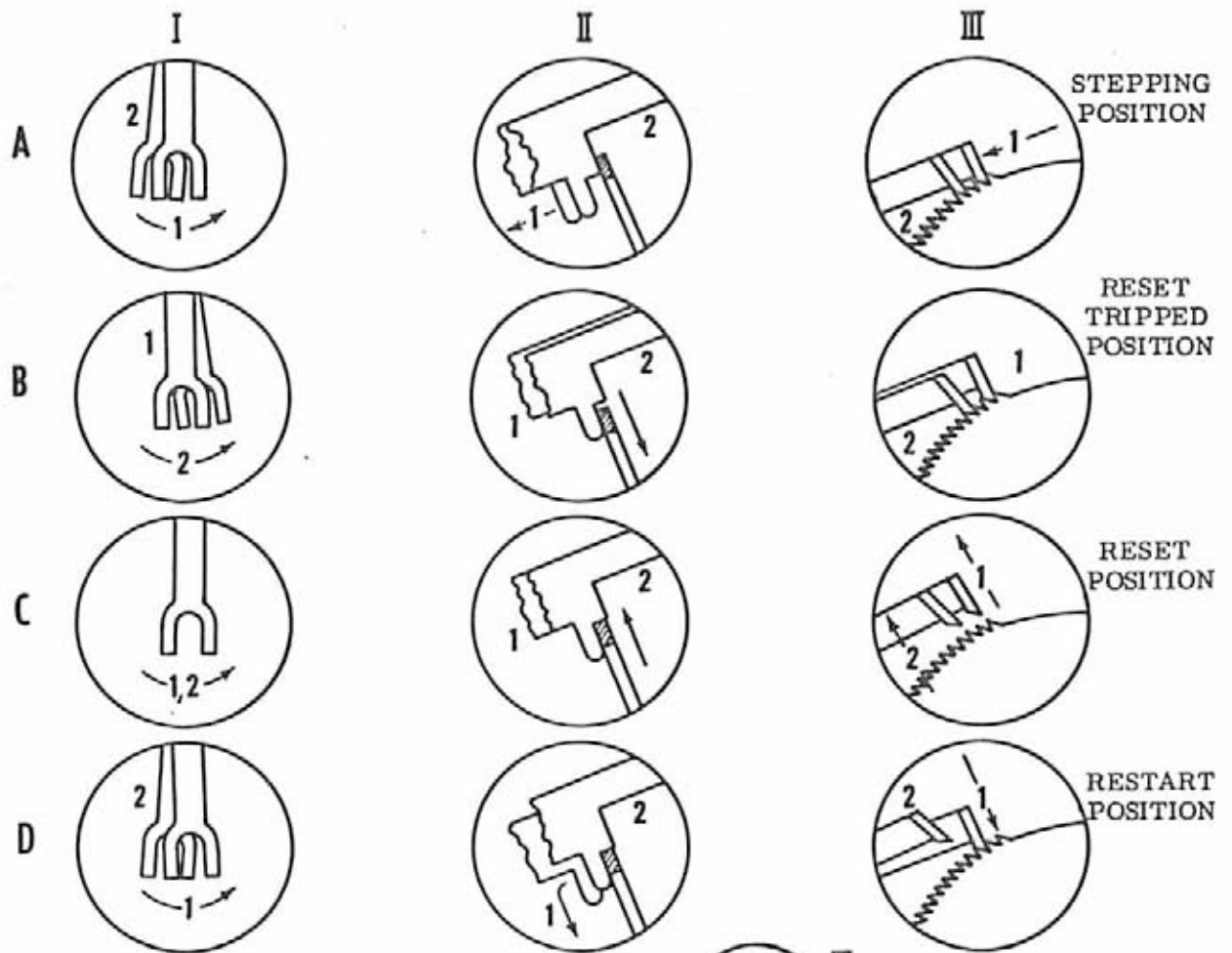

Figure 18 - Operation of Character Counter Mechanism

As the reset lever rotates clockwise, the reset lever extension moves downward until it falls under the shoulder of the projection on the drive and latchlevers under the action of its spring. When the counterbars are reset as in C, Figure 18, the reset bail is rotated clockwise to its original position, causing the reset lever to rotate counterclockwise, carrying the reset lever extension upward, and moving both the drive lever and latchlever out of engagement with the ratchet teeth. The mechanism remains in this condition and the ratchet drum assembly rotates rapidly counterclockwise (under the action of its return spring) until it reaches its zero position.

3.34 As the ratchet drum reaches its zero position, a stop on the ratchet strikes a stop lever fastened to the frame. The elastic impact is transmitted through the stop lever to the antibounce lever whose lower end is normally in contact with the stop lever. The antibounce lever rotates counterclockwise, dropping in behind the ratchet stop. As the ratchet drum rebounds from the stop lever, its stop strikes the antibounce lever, preventing further motion and maintaining the antibounce lever in its actuated position. The ratchet continues to operate between the stop lever and antibounce lever until the energy in the system has been largely dissipated. The ratchet stop then remains in contact with the stop lever, permitting the antibounce lever to return to its normal position.

#### Restart

3.35 Sequence D, Figure 18, illustrates the restarting action of the counter mechanism for the character following a carriage return. As a key on the keyboard is depressed, the counter codebar falls to the right, the feed bail moves counterclockwise and the drive lever moves to the left. As the drive lever moves to the left it is disengaged from the reset lever extension and falls into engagement with the ratchet tooth. As the codebars are reset under power, the feed bail rotates clockwise and the feed lever begins to move to the right. As it does, its projection pushes the reset lever extension to the right and out of engagement with the latchlever, which falls into engagement with the ratchet drum. As the drive lever completes its stroke, it steps the ratchet one tooth as in the normal stepping operation.

#### End-of-Line Switch

3.36 The end-of-line switch, Figure 16, operates the end-of-line indicator light located in the cabinet to signal the end of a typed

page printer line. The switch circuit is operative only when the keyboard is in the T position. In the K and K-T operating positions, the end-of-line indicator light is operated by the margin indicator switch (Paragraph 3.30). Selection of either the end-of-line indicator switch or margin indicator switch is automatically controlled by a keyboard control selection switch (Figure 21). The selection switch is, in turn, operated by the keyboard control knob.

3.37 Operation of the character counter end-of-line indicator switch is controlled by a switch cam (Figure 16). The switch cam rotates with the ratchet drum and can be adjusted to close the switch at any typed line length of from 10 to 80 characters.

#### M. Auxiliary Electric Switch (Figure 1)

3.38 This switch is of the multicircuit type. Operation of the switch is controlled by the keyboard control knob through a shaft and gears. The switch is used for various switching requirements not applicable to this section.

#### N. Tape Supply Container (Figure 1)

3.39 The tape supply container supplies the tape to the punch. The tape is guided from the container so that it traverses the punch from right to left (viewed from the front). A low-tape switch mechanism is available, as an optional feature, with the container to initiate a signal when the supply of tape is low.

#### O. Keyboard Tape Backspace

3.40 The keyboard tape backspace mechanism controls the operation of the power drive backspace mechanism on the perforator. It consists of a tape backspace (TAPE B. SP.) key-lever and a tape backspace switch.

3.41 When the TAPE B. SP. keylever is depressed, it causes its associated lever arm to contact and depress the actuating button on the backspace switch. As this happens, the circuit to the backspace magnet of the power drive backspace mechanism on the perforator is closed, and power is applied to the magnet. The power drive backspace mechanism will then move the perforated tape backward one space each time the TAPE B. SP. keylever is depressed. See appropriate sections of perforator units for operation of power backspace mechanism.

## KEYBOARD-PERFORATOR LINKAGE MECHANISM (Figure 19)

### A. General

3.42 The keyboard-perforator linkage consists principally of a codebar extension basket mechanism, and a reset cam follower bracket mechanism. The functions of the codebar extension basket mechanism are to transmit character information from the keyboard codebars to the perforator, and to control the operation of the perforator-transmitter in the K, K-T, and T positions. The reset cam follower mechanism provides the linkage between the clutch tripbar and the perforator cam in the T position to permit the keyboard to be reset at high speeds by the tape perforator.

### B. Operation in K Position

3.43 In this position, signals are generated by the keyboard as described in Paragraph 2 and the perforator is inoperative. This mode

of operation is set up by turning the keyboard control knob to the K position. This conditions the keyboard-perforator linkage as follows:

(a) When the keyboard control knob (Figure 19) is turned to the K position, the blocking bail shown in the illustration is moved to the left to the dotted position by the action of the control cam. When a codebar is selected and falls to the right, the codebar extension is prevented from moving to the right by the blocking bail and, therefore, information is not transmitted to the punch. An extension on the blocking bail also prevents selection of the character counter codebars (Paragraph 3. L.).

(b) As the blocking bail moves to the left, a second extension (Figure 20) engages a bell crank and pivots the bell crank clockwise. This disengages the latch from the clutch tripbar link so that, as the clutch tripbar falls to the right, the clutch tripbar link remains in the position shown and the perforator clutch is not tripped.

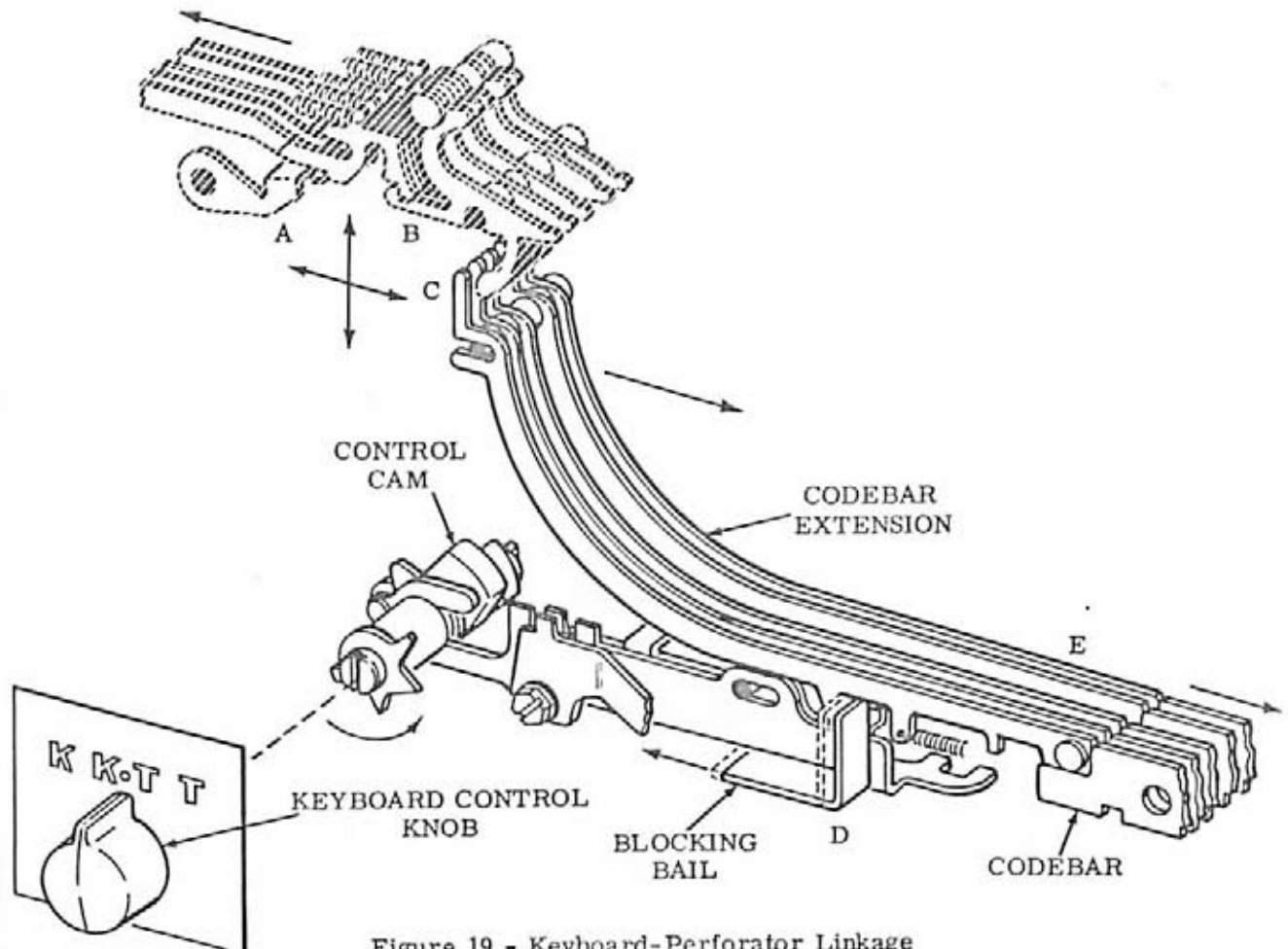

Figure 19 - Keyboard-Perforator Linkage

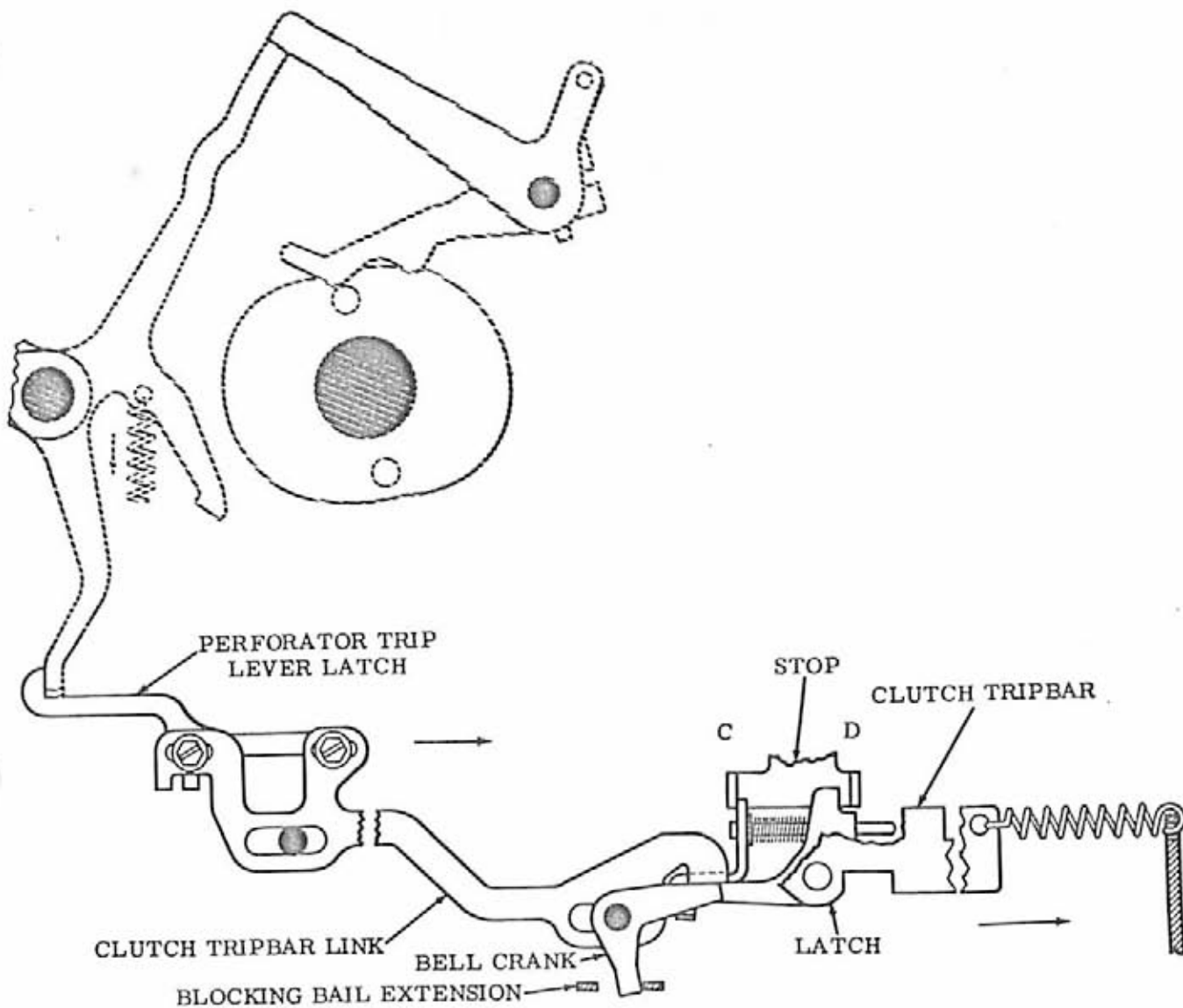

Figure 20 - Perforator Clutch Trip Linkage

(c) The keyboard control selection lever (Figure 21) is pivoted counterclockwise so that its pin at point B is free of the hook on the reset lever of the reset cam follower mechanism. At the same time, the extension on the right end of the keyboard control selection lever moves up to the dotted position shown at C so that, as the clutch tripbar falls to the right, the extension strikes the signal generator clutch trip lever, operating the signal generator mechanism.

### C. Operation in K-T Position

3.44 In this position, signals are generated by the keyboard and tape is simultaneously perforated. This mode of operation is setup by

turning the keyboard control knob to the K-T position. This conditions the keyboard-perforator linkage as follows:

- (a) When the keyboard control knob is moved to the K-T position, the blocking ball shown in Figure 19 moves to the right, releasing the codebar extensions and character countercodebars. The bell crank (Figure 20) pivots counterclockwise, allowing the latch to engage the clutch tripbar link.
- (b) The keyboard control selection lever (Figure 21) remains in its counterclockwise position so that it is not engaged by the reset lever of the reset cam follower, but is still in position to trip the signal generator clutch trip lever.

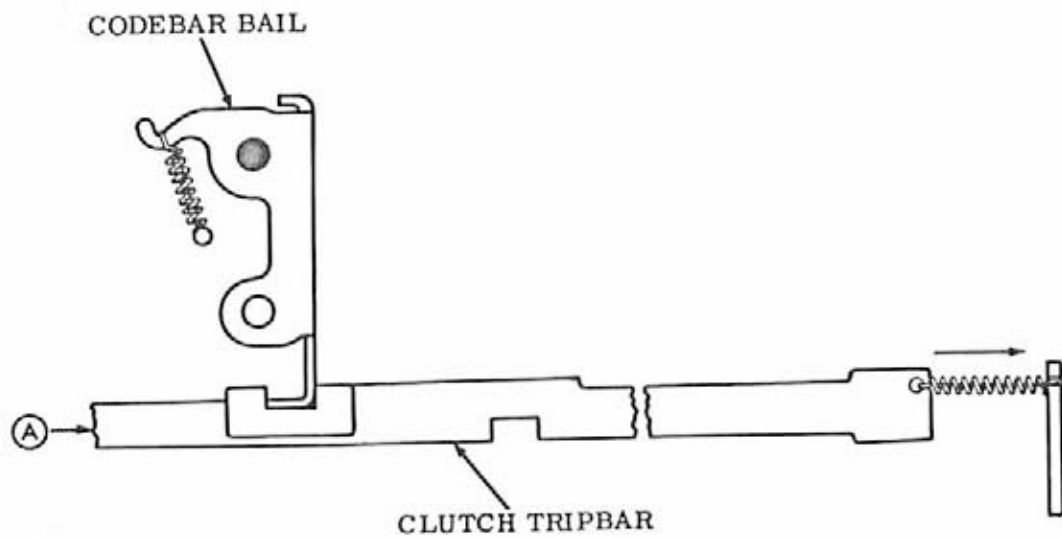
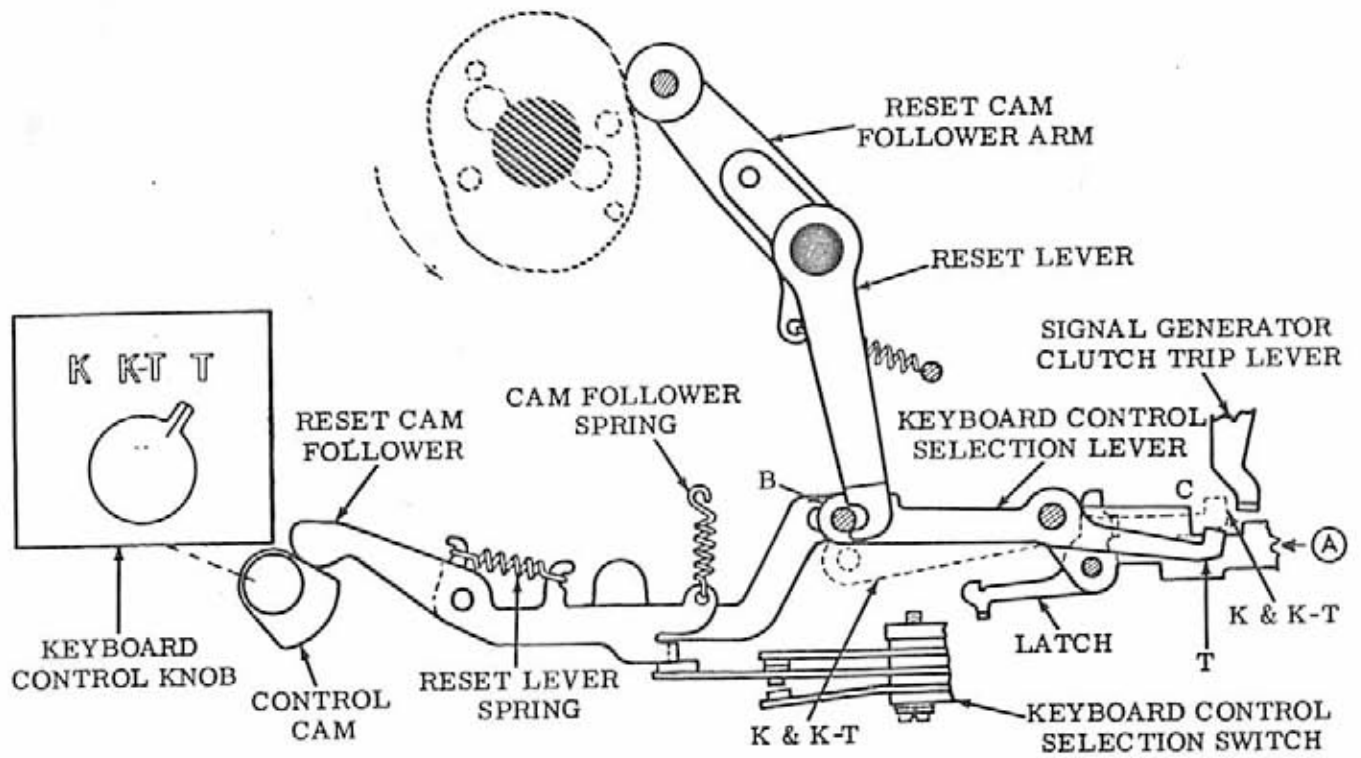

Figure 21 - Mode Selection and Keyboard Reset Mechanism

(c) The character counter codebars are released so that the character will count; however, its end-of-line switch is inoperative due to the position of the keyboard control selection switch (Figure 21). Refer to Paragraph 3.L. for a description of the control switch operation.

(d) When a code keylever is depressed, the clutch tripbar falls and the following sequence takes place:

(1) The codebar bail and clutch tripbar move to the right, thereby releasing the selected codebars. The selected codebars and associated codebar extensions (Figure 19) move to the right. As the codebar extensions move to the right, they engage their associated punch slide latches at C on the perforator, causing the punch slide latches to rotate counterclockwise and unlock the punch slides at B.

(2) The clutch tripbar link (Figure 20) is pulled to the right by the clutch tripbar. The clutch tripbar link is coupled to the perforator trip lever latch. This latch contacts the perforator trip lever at B, causing it to rotate counterclockwise. As it moves counterclockwise, the perforator trip lever is disengaged from the clutch release at A. The clutch release falls under spring tension and releases the perforator clutch trip lever which, in turn, trips the perforator clutch. The signal generator clutch is tripped as previously described.

(3) As the perforator trip lever rotates counterclockwise, the reset bail trip lever linked to it (Figure 20) pulls down an extension on the punch slide reset bail at E. The reset bail moves down, permitting the selected punch slides (Figure 19) to move to the left under action of their bias springs.

(4) As the clutch tripbar nears the end of its stroke to the right, the upper portion of the latch comes in contact with the stop at point D. The latch then pivots counterclockwise, releasing the clutch tripbar link which moves rapidly to the left under the action of the compression spring shown immediately below the stop. The clutch tripbar link is stopped in its movement to the left by its extension striking the stop at point C. The perforator

trip lever latch is to the left of and completely free of the perforator trip lever. As the clutch release pivots clockwise under the resulting action of the pin on the reset cam, the perforator trip lever is released from its counterclockwise position and allowed to rotate clockwise to its normal position as shown in Figure 20.

(5) In the meantime, the clutch tripbar (Figure 20) is being reset and is moving to the left. As the latch moves to the left away from the stop at point D, it pivots clockwise to its normal position so that when the clutch tripbar is at the extreme left of its reset travel, the latch is again allowed to hook under the clutch tripbar link. This completes the operating cycle.

#### D. Operation in T Position

3.45 In this position, tape is perforated by the perforator but no signals are generated by the keyboard. The keyboard is reset by the perforator since the signal generator mechanism is inoperative. This mode of operation is set up by turning the keyboard control knob to the T position. This conditions the keyboard-perforator linkage as follows:

(a) When the keyboard control knob is turned to the T position, the keyboard control selection lever (Figure 21) is pivoted clockwise so that its pin at point B is in position to engage the hook of the reset cam follower reset lever. The right end of the keyboard control selection lever at point C falls so that it will not engage the signal generator clutch trip lever. In the T position, therefore, the signal generator clutch is not tripped and the signal generator is inoperative.

(b) The keyboard perforator linkage and perforator clutch trip system operate as described in Paragraph C. above. The character counter is operative and controls the end-of-line indicator light as described in Paragraph 3.L.

(c) Codebar reset is effected by the reset cam follower mechanism. When a code keylever on the keyboard is depressed, the codebar bail and clutch tripbar (Figure 21) fall to the right so that the reset lever with hook is in position to engage the pin of the keyboard control selection lever at point B. When the perforator clutch is tripped, the reset cam begins to rotate counterclockwise

and, as it does, the reset cam follower arm and associated reset lever rotate clockwise. The hook on the reset lever engages the pin on the keyboard control selection lever and moves the selection lever and clutch tripbar to the left. The configuration of the reset cam is such that, at a later stage of the operating cycle, the reset lever with hook moves away from the pin of the keyboard control selection lever. The clutch tripbar again starts to move to the right. However, the codebar bail latch latches the codebar bail at this point, preventing further movement of the clutch tripbar as the reset cam follower arm returns to its initial position.

#### 4. VARIABLE FEATURES

##### ANSWER-BACK MECHANISM (Figures 22 and 23)

4.01 The answer-back mechanism is an electromechanical device which permits the identity of a called station to be transmitted automatically to the originating station, in response to a coded, sequential message from the signal line. The HERE IS keytop provides manual operation. Transmissions are generated in the normal manner by the keyboard, which, through its codebar mechanism, reads the code combination contained in a message drum.

4.02 The mechanism is comprised basically, of a coded message drum, control relay, and keyboard contacts. The drum is coded for

the desired combination by removing code lines from the 21 code blades, as required (Figure 22). The first character transmitted is always a LTRS combination to place the called station in the unshift position; the other 20 may be any characters desired. However, the first transmission is usually followed by CR (carriage return) and LF (line feed). This sequence is also typically used to end a coded sequence, to insure that the answer-back message will appear at the beginning of a line at the distant station, and that over-printing of the message will not occur. Typically, 16 characters are available for the answer-back identification.

4.03 The following explanation of operation uses the combination FIGS - D as an example. The combination used may vary with the application.

##### A. Called Station

4.04 The answer-back message is initiated at the called station by depressing the FIGS, upper case D combination at the originating station. The operation of the FIGS function box contact at the called station will de-energize the answer-back (noncontention) control relay if this relay is in an energized condition prior to the reception of the FIGS combination. The closing of the D function box contact then completes a circuit to the answer-back trip magnet via normally closed control relay contacts. The

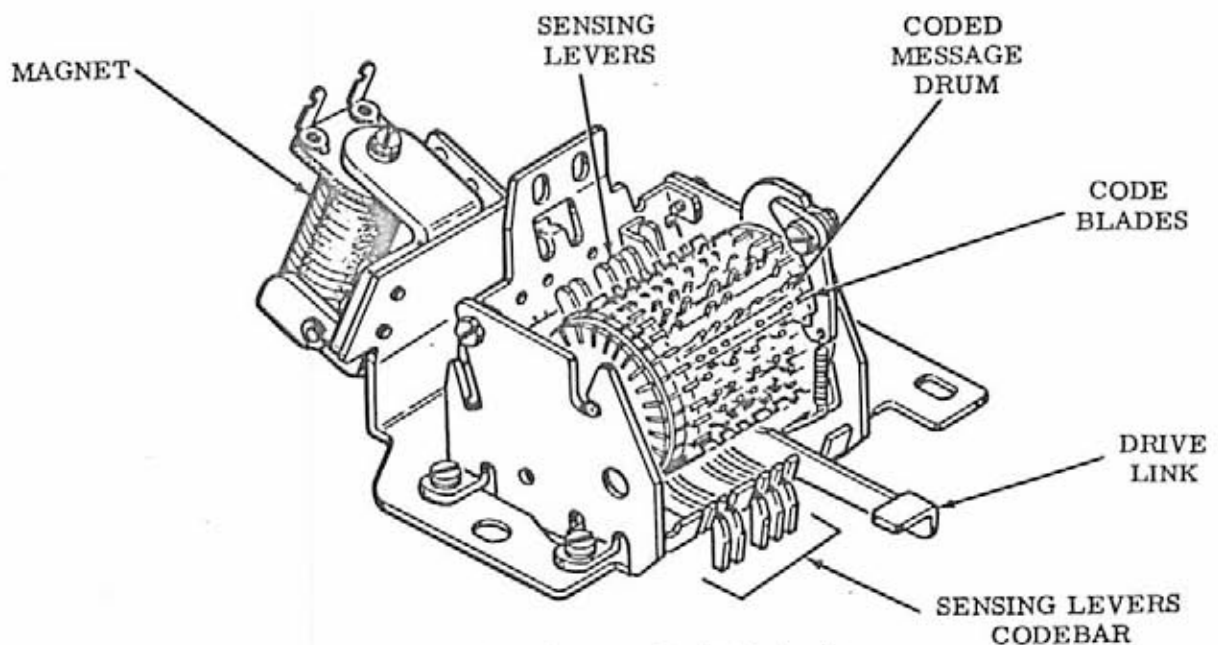

Figure 22 - Answer-Back Mechanism

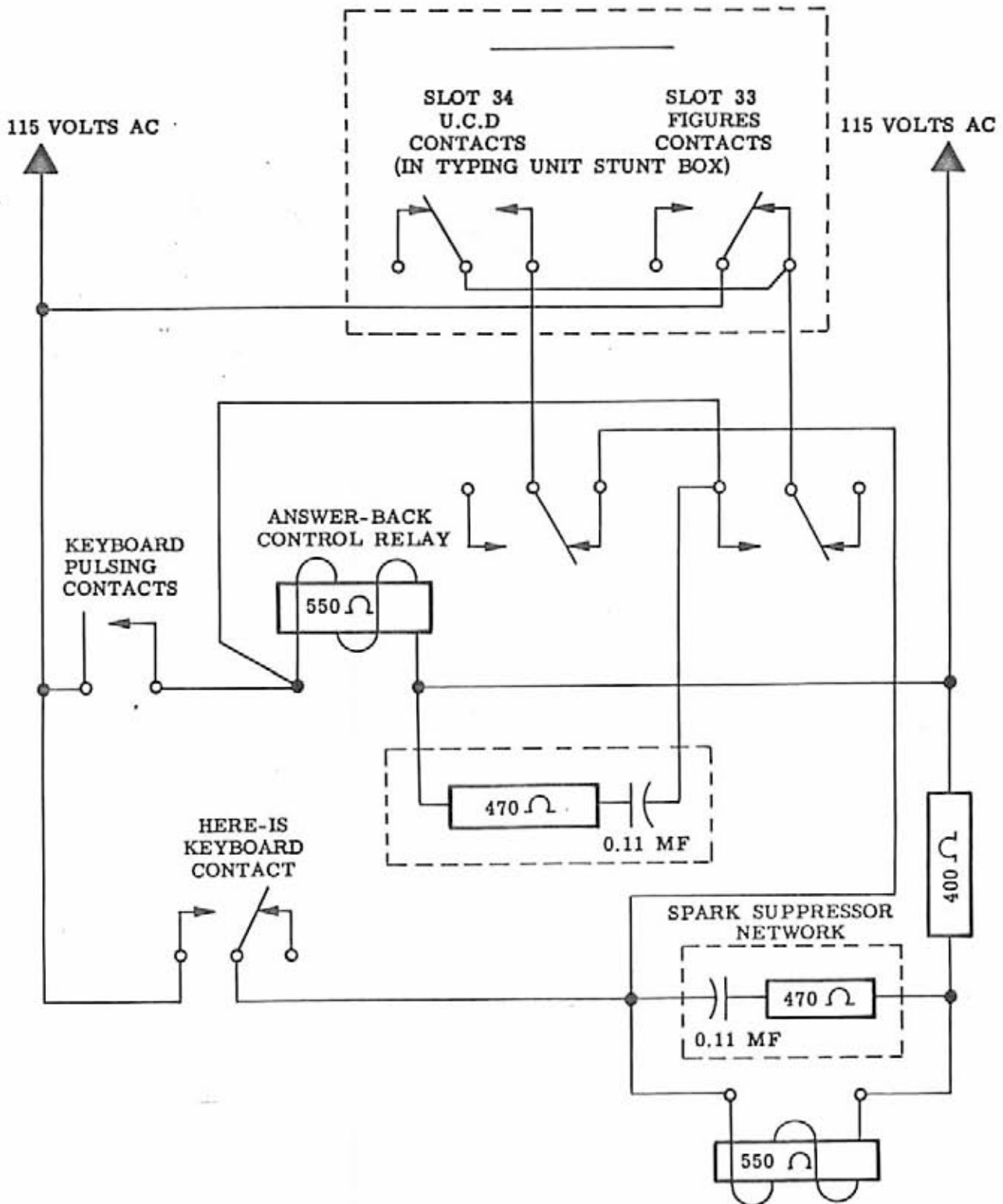

Figure 23 - Typical Answer-Back Circuit



D contact also locks the keyboard through a lever extension to the keyboard locking mechanism, if the set is so equipped. This is accomplished when the blank keylever is depressed twice in succession.

4.05 The closure of this circuit energizes the answer-back trip magnet and results in the counterclockwise rotation of the armature and associated stop-lever latch, thereby unblocking and releasing the stop lever. Under the bias of a spring attached to the codebar bail latch operating lever, the stop lever rotates counterclockwise until it comes to rest against the mechanism base plate. Before coming to rest the stop lever moves the blocking lever counterclockwise, thereby unblocking the drive plate and releasing it to its spring action. The drive plate rotates counterclockwise to a stop where the attached drive link is in a position to accept the feeding motion from the keyboard codebar bail. As the stop lever continues its counterclockwise rotation, the codebar bail latch operating lever rotates clockwise, striking the codebar bail latch. The latch rotates clockwise and releases the codebar bail. The codebar bail releases the keyboard codebars and the clutch tripbar, which move to the right under spring action. The clutch tripbar thereby trips the signal generator clutch and initiates an operating cycle.

4.06 The code combination transmitted during the first cycle must be a letters combination. The code combinations of the succeeding 20 cycles may be any arbitrary character determined by the detachable code blades fastened to the code drum. The code combination on each blade is read by five sensing levers which transfer the code selections to a vertical projection on each of the 5 codebars. Each code combination is thus transmitted in the normal manner by the keyboard signal generator mechanism. A spacing condition occurs whenever a codebar is prevented from moving to the right by its associated sensing lever; unrestricted movement of a codebar results in a marking condition. Since the sensing levers must be held away from the codebars, in order to prevent their interference during normal keyboard operation, a stop code blade having a letters combination is used. This results in a letters combination for the first character.

4.07 Once during each rotation of the signal generator cam assembly, the codebar bail is pulled to the left by a cam eccentric, causing it to rotate clockwise. The bail thereby

resets the keyboard codebars and, with the character generator drive link now in its released position, rotates the drive plate clockwise. This action causes the stepping pawl to step the code drum one position clockwise.

4.08 With the stop lever in its released position, the codebar bail latch operating lever also maintains the codebar bail latch in a released position. The signal generator mechanism will cycle continuously until it rotates the code drum one full revolution or 21 characters. The first code blade, which is the stop code blade having a letters combination, has an additional projection. When it is being rotated into the sensing position, the projection contacts the stop lever, rotating it clockwise. The left extension of the stop lever rotates the codebar bail latch operating lever counterclockwise, which in turn releases the codebar bail latch to the action of its attached spring. Continued rotation of the stop lever brings it in a position where if released to the action of the spring attached to the codebar bail latch operating lever, it will reverse rotation and become latched on the stop lever attached to the trip magnet armature. Such a position is reached when the stop code blade passes its area of contact with the stop lever, which is just prior to the complete movement of the stop code blade into the sensing position.

4.09 When the codebar bail latch is released to its spring action, it rotates counterclockwise in contact with the codebar bail latch roller until it latches the codebar bail. At this point the blocking lever is also released to its spring action, and it rotates counterclockwise until it rests against a projection on the stop lever. In this position the blocking lever holds the drive plate in its extreme clockwise position and the attached drive link is once more unable to follow the feeding motion from the codebar bail. Further operation of the signal generator and character generator is thus prevented. At this point the operator must manually unlock the keyboard to restore it to its normal operating condition if the set is equipped with a keyboard locking mechanism.

## B. Originating Station

4.10 The keyboard pulsing (or blinding) contact, mounted on the signal generator assembly, is operated every keyboard cycle by a cam which is mounted on the signal generator shaft. The pulsing contact is timed to close before the beginning of the start pulse and remain closed until after the end of the 5th pulse.

4.11 Each time it operates, the keyboard pulsing contact will energize the answer-back control relay; the control relay will remain energized via its own contacts, and the FIGS stunt box contact.

4.12 The FIGS stunt box function pawl in the typing unit is specially designed to engage the FIGS function bar at all times. The pawl is never stripped by the stripper bail. This means that the function pawl holds the function lever away from the FIGS contact. When the FIGS function bar is selected, it will permit the pawl and lever to move forward and operate the FIGS contact. (The normal stunt box operation is such that the contact does not operate until the selected function bar has first moved forward and then rearward.) This arrangement converts a normally open, momentary-operate FIGS contact to a normally closed, momentary-operate FIGS contact. At the same time, it advances the timing of the FIGS contact operation to insure that either the FIGS contact or the keyboard pulsing contact will keep the control relay energized during every signal generator cycle.

4.13 The local operator depresses the FIGS - D combination to call the remote station. The FIGS contact may or may not de-energize the control relay depending upon how long afterwards the operator depresses the D combination. In any event, the D combination will again energize the control relay, if necessary. The local answer-back will, therefore, be disabled due to the opening of the normally closed con-

trol relay contacts, which are in series with answer-back trip magnet.

SYNCHRONOUS PULSED TRANSMISSION (Figures 1 and 24)

4.14 Upon operation of the appropriate key-lever, the reset bail in the keyboard is moved to the right and releases the selected codebars. The universal codebar (a modified clutch tripbar) is released and moved to the right also, at which time it closes the clutch magnet conditioning contact. This action enables the clutch trip magnet to respond to an externally supplied synchronous pulse (50 or 100 milliamperes of 20 millisecond duration). When energized by the synchronous pulse, the clutch trip magnet releases and moves the clutch tripbar to the right. This movement causes the clutch tripbar extension to trip the signal generator clutch. The signal generator camshaft then rotates and transmits the selected signal.

4.15 During the single rotation of the signal generator camshaft, the reset bail is rotated clockwise and latched. The universal codebar, clutch tripbar, and the five codebars are moved and held to the left by the reset bail.

TIME DELAY MECHANISM (Figure 25)

4.16 The time delay mechanism operates in conjunction with the motor control mechanism in the electrical service unit. It provides automatic motor unit stop after a predetermined

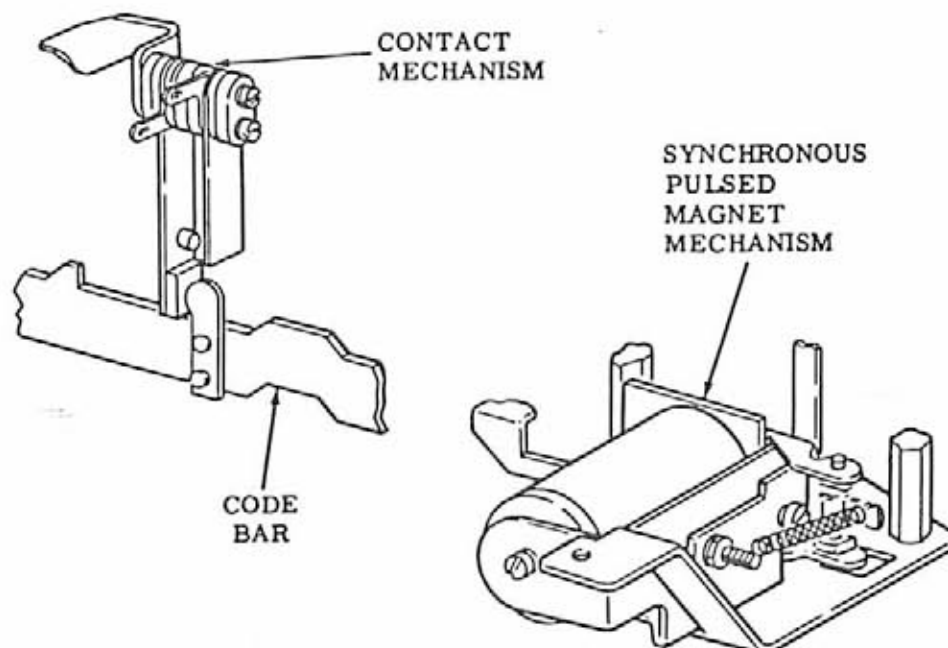

Figure 24 - Synchronous Pulsed Transmission Mechanism

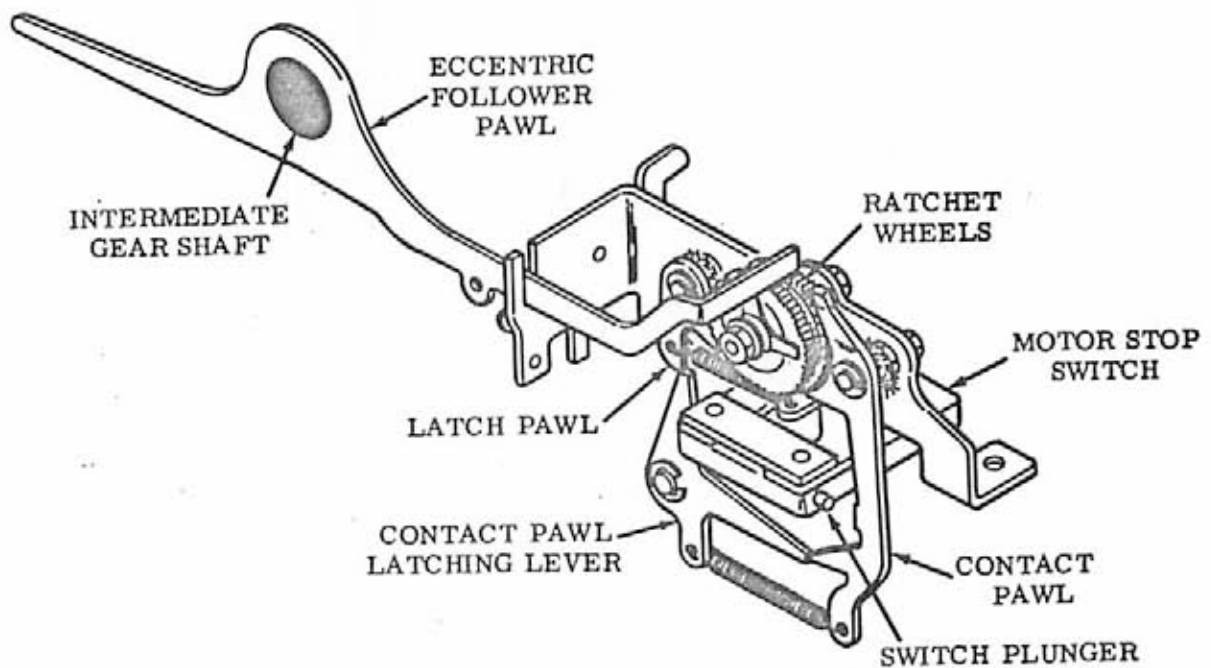

Figure 25 - Time Delay Mechanism

interval of idle signal line time has elapsed. The mechanism contains two ratchet wheels — one with 27 teeth, and one with 28 teeth. A reciprocating eccentric follower pawl, powered by the keyboard intermediate shaft, drives the ratchet wheels, one tooth at a time. The latch pawl rides the inside flanges of the ratchet wheels and controls the contact pawl latching lever, which holds the contact pawl away from the flanges. Each ratchet wheel has an indentation in its inside flange. After a maximum of 756 revolutions of the intermediate shaft, these indentations are adjacent for almost one revolution. When the adjacent indentations pass over the latch pawl, it drops into them, briefly, and then disengages the contact pawl latching lever from the contact pawl. This permits the contact pawl to ride the flanges of the ratchet wheels until either one of two events occur.

4.17 If a line signal is received before 756 revolutions of the intermediate shaft, the typing unit main bail drive extension engages the upper end of the contact pawl and causes it to again be latched by the contact pawl latching

lever. This begins a new cycle of time measurement.

4.18 If a line signal is not received before 756 revolutions of the intermediate shaft, the indentations in the flanges of the ratchet wheels again become adjacent and permit the contact pawl to drop. This action results in a pulse transmission to the motor control mechanism, which responds by switching off the motor unit.

4.19 The time elapsed between the reception of the last line signal and the stopping of the motor unit varies with the operating speed. For 60 wpm, the range is 86 to 172 seconds; 75 wpm, 60 to 120 seconds; and 100 wpm, 53 to 106 seconds.

4.20 The mechanism may be disabled by adjusting an eccentric that moves the eccentric follower pawl out of engagement with the ratchet wheels. Motor unit operation may be restored by opening the signal line circuit (eg, depressing the BREAK keylever).

This page intentionally left blank

28 AUXILIARY TYPING REPERFORATOR BASE  
FOR THE AUTOMATIC SEND-RECEIVE (ASR) SET

DESCRIPTION

1. GENERAL

1.01 This section describes the base assembly used only in the Automatic Send-Receive (ASR) Set for mounting an auxiliary typing reperforator unit. The accompanying photograph shows a typical base.

2. PHYSICAL CHARACTERISTICS

2.01 The base is a simple designed structure of steel plates which serve as a mounting for a typing reperforator, a motor unit, tape container, gear bracket assembly, and a bracket on which electrical connections are made.

2.02 The gear bracket assembly, driven directly by a motor, may contain two shafts with interchangeable gears for speed change, or it may be a gear shift assembly by which speed change may be accomplished by moving a lever to any one of three positions. A reperforator driving sprocket is mounted on the gear assembly for driving the reperforator unit by means of a timing belt.

2.03 Motor mounting facilities are provided on the lower level of the base so that the motor is located in position for driving the gear assembly.

2.04 The tape container accommodates a full roll of tape, which is directed out through a tape guide with roller to the typing reperforator. A low tape electrical switch assembly is provided in the tape container. A tape-out switch lever rides the diminishing roll of tape to actuate an electrical switch when a prescribed level is reached.

3. ELECTRICAL CHARACTERISTICS

3.01 The electrical connections are made on a bracket assembly adjacent to the tape container. A power cable connector is provided to accept electrical power from the cabinet terminal board.

3.02 A power switch provides means for switching power to and from the auxiliary typing reperforator unit.

3.03 A 36-point connector is provided to accept cable connections from an associated electrical service unit.

3.04 From the 36-point connector a cable emerges to carry electrical connections to a connector on the typing reperforator.

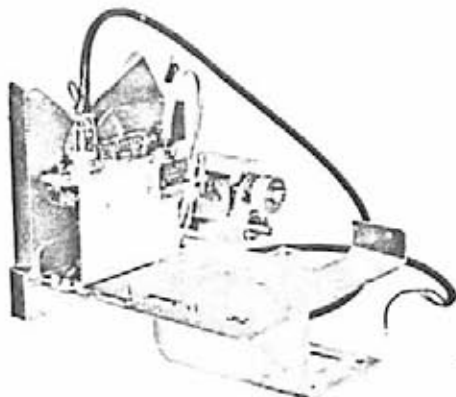

Typical ASR Auxiliary Typing Reperforator Base

This page intentionally left blank

28 TRANSMITTER DISTRIBUTOR BASE FOR THE  
AUTOMATIC SEND-RECEIVE (ASR) SET

DESCRIPTION

1. GENERAL

1.01 This section describes the transmitter distributor base used in the Automatic Send-Receive (ASR) Set to mount the transmitter distributor unit. The accompanying photograph shows a typical base.

2. PHYSICAL CHARACTERISTICS

2.01 In general, all bases used as mountings for the transmitter distributor in an ASR Set are similar in structure. They consist of an aluminum casting designed to be mounted on the cradle in the left side of the ASR cabinet.

2.02 The transmitter distributor base serves as a mounting for two drive shafts with bearings, and a gear. These shafts are at a right angle to each other and transfer driving motion from the power shaft of the perforator-transmitter base to the transmitter distributor.

2.03 The speed at which the transmitter distributor runs may be changed by changing the set of gears between the two shafts. These gears are not considered a part of the base.

2.04 Where necessary, adjustable stops are provided to determine the front to rear position of the transmitter distributor.

2.05 A gear guard is provided for the speed gears as a safety measure and for protection of the gears.

3. ELECTRICAL CHARACTERISTICS

3.01 Most of the early designed transmitter distributor bases have no electrical connections. Later designed bases and some early designed bases, however, have a cable with a connector at each end. These connectors are fastened to the base by brackets in a suitable location for connecting electrical circuits from the transmitter distributor to an associated electrical service unit cable.

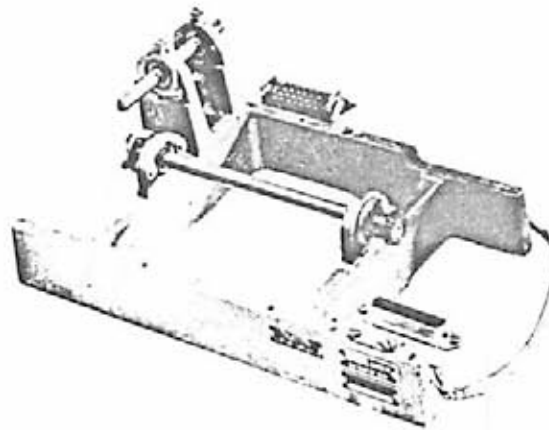

Typical ASR Transmitter Distributor Base

This page intentionally left blank



28 TELETYPEWRITER CABINET FOR  
AUTOMATIC SEND-RECEIVE (ASR) SETS

DESCRIPTION

CONTENTS	PAGE
1. GENERAL. . . . .	1
2. DESCRIPTION. . . . .	1

1. GENERAL

1.01 This section describes the 28 teletypewriter cabinet for the Automatic Send-Receive (ASR) Set. For information pertaining to the ASR Set or any of its components, refer to the appropriate section.

1.02 The directions — up or down, front or rear, and left or right, as given in this section, are as viewed from an operator's position.

1.03 A cabinet is an enclosure with its cover and all external faceplates. The cabinet protects the enclosed components against dust, possible damage from external sources, and reduces the operating noise level. Figures 1 and 2 show a typical 28 teletypewriter cabinet for the ASR Set.

1.04 The cabinet, of sheet metal construction, is finished internally and externally in baked enamel. The cabinet is 38-1/2 inches high, 46 inches wide with the offset copyholder (36 inches wide without the offset copyholder), 18-1/4 inches deep, and weighs approximately 150 pounds.

2. DESCRIPTION

2.01 The cabinet houses all the basic components, ie, keyboard, typing unit, perforator or reperforator, transmitter distributor, transmitter distributor base, electrical service unit, and motor; plus all required auxiliary equipment. Such auxiliary equipment would be a typing reperforator, a typing reperforator base and a motor, all mounted on the shelf, and

an auxiliary electrical service unit mounted on a rack in the lower compartment of the cabinet.

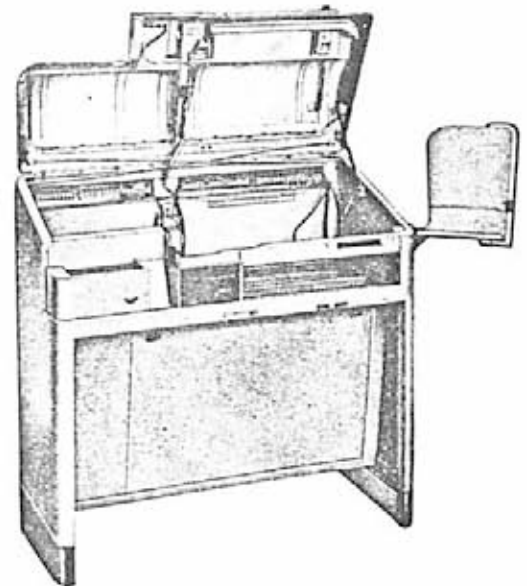

Figure 1 - Typical 28 Teletypewriter Cabinet for Automatic Send-Receive (ASR) Sets (Dome Cover Open)

2.02 A shelf divides the cabinet into an upper compartment and a lower compartment or pedestal. The upper compartment houses the keyboard base, typing unit, electrical service unit, and the auxiliary typing reperforator (if supplied). The lower compartment houses accessory equipment and is used for storage.

2.03 The upper compartment has a dome-shaped cover hinged at the rear. The cover is unlatched by a pushbutton and is counterbalanced by a stop arm mechanism that aids in raising and supporting it in the open position.

2.04 Openings in the dome cover provide access to components without raising the entire cover. The right door on the dome cover (Figure 2) provides access to the rear of the

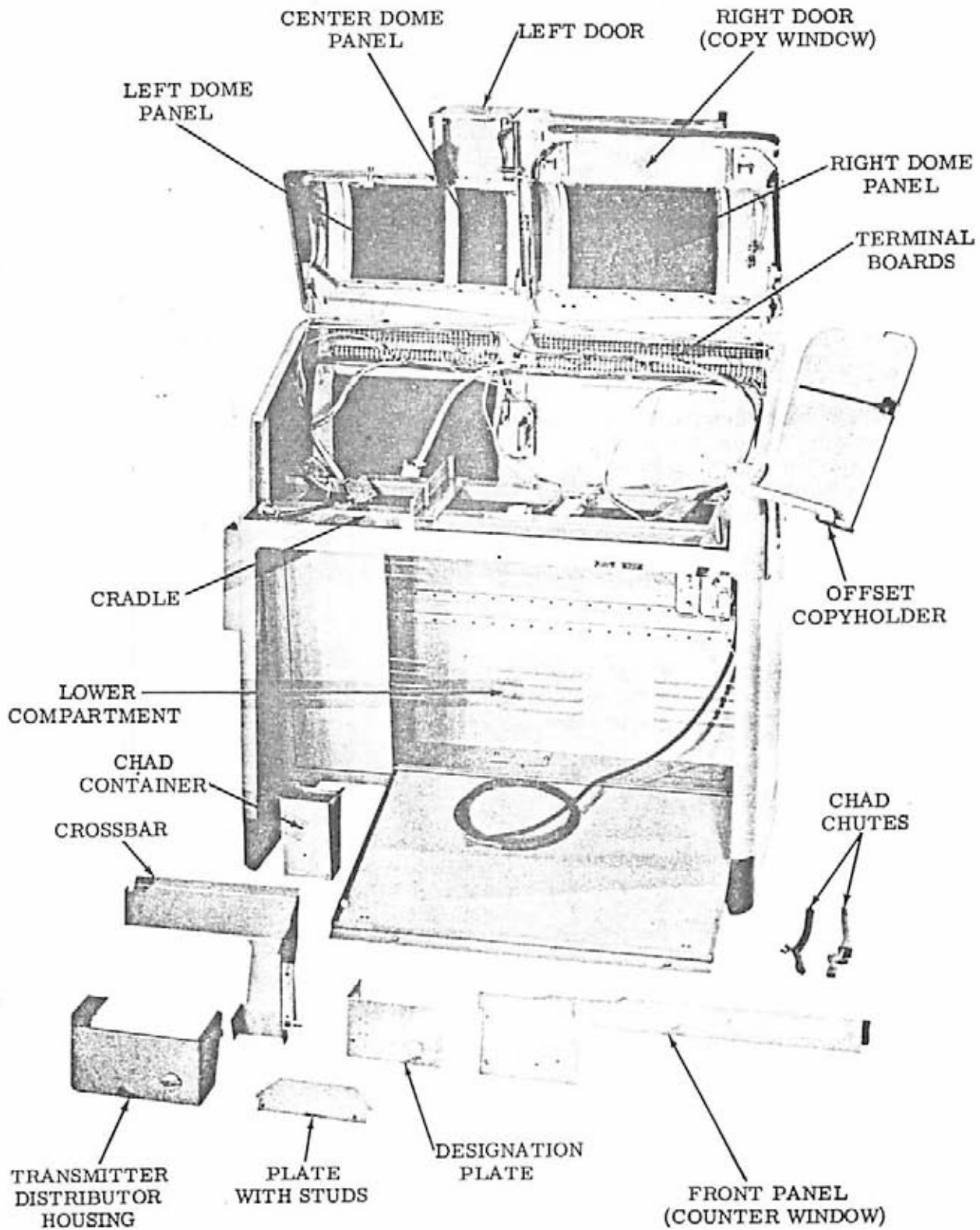

Figure 2 - 28 Teletypewriter Cabinet for Automatic Send-Receive (ASR) Sets (Dome Cover Open)

typing unit for changing the copy paper. A window in this door affords a view of the platen, typebox, and the copy being typed. The rear of the window serves as a straight edge for tearing off printed copy. The hinged left door near the center can be raised to gain access to the perforator. Two windows in the door are provided for viewing the perforated tape, the left window serving as a tape cutoff guide. The hinged left dome panel can be raised to gain access to the auxiliary reperforator, if it is supplied.

2.05 Incandescent indicator and copy lamps, located under the dome cover, illuminate the printed copy. A three-position switch, accessible when the dome cover is raised, controls the copy lamps. The copy lamp switch provides the following operating modes: NORMAL ON, OFF, and MAINT ON (maintenance on).

2.06 A cradle assembly resting on vibration mounts on the floor of the upper compartment accommodates both a keyboard base and a transmitter distributor base.

2.07 Terminal boards for power and signal line connections are located on the inner rear wall. The electrical service unit is placed to the rear of the keyboard base. Its power switch is controlled through a lever at the front of the cabinet.

2.08 Rubber sealing strips, applied to the edges of both the dome cover and the lower compartment, help reduce the operating noise level.

2.09 The cabinet may be equipped with many accessories such as:

- (a) A signal bell, to make audible those signals that are transmitted for supervisory purposes.
- (b) Electrical noise suppressors, to minimize electromagnetic radiation from the signal and power lines.
- (c) A margin indicator lamp, which may be equipped with a line balancing resistor.
- (d) A small copyholder and line guide.
- (e) An offset copyholder.
- (f) An apparatus mounting rack for mounting accessory equipment.
- (g) A directory holder.
- (h) Four threaded leveling feet to compensate for floor irregularities or to add up to one inch in height to the cabinet.
- (i) A tape bin with door.

This page intentionally left blank

28 TYPING AND NONTYPING PERFORATORS  
DESCRIPTION AND PRINCIPLES OF OPERATION

CONTENTS	PAGE	CONTENTS	PAGE
1. GENERAL . . . . .	1	C. Printing . . . . .	21
2. GENERAL DESCRIPTION . . . . .	2	D. Ribbon Feeding . . . . .	21
CODE . . . . .	2	TAPE PERFORATING AND FEEDING . . . . .	23
3. DETAILED DESCRIPTION . . . . .	2	A. General . . . . .	23
FUNCTION . . . . .	2	B. Perforating — Fully-Perforated Units . . . . .	23
SELECTION . . . . .	3	C. Perforating — Chadless Units . . . . .	23
PERFORATING . . . . .	3	D. Feeding — Fully-Perforated and Chadless Units . . . . .	26
TYPING . . . . .	3	5. VARIABLE FEATURES . . . . .	25
VARIABLE FEATURES . . . . .	4	BACKSPACE MECHANISMS . . . . .	25
4. PRINCIPLES OF OPERATION . . . . .	4	A. General . . . . .	25
GENERAL . . . . .	4	B. Manual Backspace (Fully- Perforated Tape) . . . . .	25
SELECTION AND TRANSLATION . . . . .	5	C. Manual Backspace (Chadless Tape) . . . . .	25
A. Clutch Operation . . . . .	5	D. Power Drive Backspace . . . . .	25
One-Stop Clutch Operation . . . . .	5	CODE READING CONTACT MECHANISM . . . . .	25
Two-Stop Clutch Operation . . . . .	7	AUXILIARY TIMING CONTACT MECHANISM . . . . .	27
B. Transfer . . . . .	8	1. GENERAL	
MOTION FOR TYPING AND PERFORATING . . . . .	8	1.01 This section provides a description and outlines the principles of operation for two types of perforators: one a nontyping per- forator and the other a typing perforator.	
A. General . . . . .	8	1.02 The following description and principles of operation will apply to both units except for that portion pertaining to typing mechanism only.	
B. Function Cam Clutch and Clutch Trip Assembly . . . . .	9	1.03 In this section, reference to left or right indicates the operators left or right facing the front of the unit in its operating position.	
C. Rocker Bail . . . . .	9		
TYPING . . . . .	10		
A. General . . . . .	10		
B. Typewheel Positioning . . . . .	11		
General . . . . .	11		
Rotary Positioning . . . . .	12		
Axial Positioning . . . . .	18		
Correction . . . . .	20		
Letters-Figures Shift . . . . .	20		

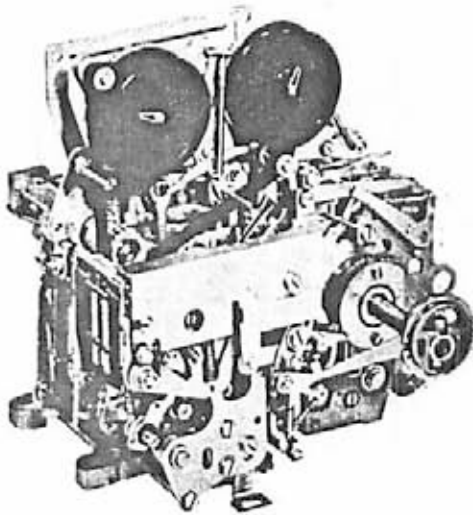

Figure 1 - Typing Perforator

## 2. GENERAL DESCRIPTION

2.01 The 28 typing and nontyping perforators are mechanical units that are used with an associated keyboard from which code selections are derived and mechanically transferred into the perforator (Figures 1 and 2).

2.02 The perforators produce a coded, perforated tape as dictated by its associated keyboard. Two types of perforators are available: a nontyping perforator and a typing perforator. Each type is capable of producing either chadless tape or fully perforated tape. The typing perforator is capable of producing perforated tape and typing thereon simultaneously. The tape may be chadless with typing on top of the chads which are not completely severed, or it may be fully perforated tape with typing between the feed holes.

2.03 In general the two units have the same function and perforating mechanisms, but the typing perforator has, in addition, the necessary mechanisms to perform typing on tape.

2.04 Each unit receives its driving power from a motor unit through drive shafting on the associated keyboard. Selection is derived mechanically from the keyboard.

2.05 A perforator consists principally of a two-shaft drive mechanism, function mechanism, transfer mechanism, perforating mechanism, and a typing mechanism for the typing perforator only (Figures 3 and 5).

## CODE

2.06 The code combinations are set up by simultaneous selection of the punch slides. If a punch slide is released by its latch, it represents a marking condition. If a punch slide is not released by its latch, it represents a spacing condition. Every code combination includes five elements that carry the intelligence, each of which may be either marking or spacing. Marking elements in the intelligence code produce holes in the tape whereas spacing elements do not. The row of smaller holes between the second and third levels are tape feed holes and do not enter into the code permutation.

2.07 The total number of permutations of a five-unit code is two to the fifth power, or 32. In order to produce more than 32 characters and functions, a letters-figures shift operation is designed into the typing equipment. This permits each permutation, excluding those used to shift and unshift the apparatus, to represent two characters or functions. Figure 7 shows the code combinations.

## 3. DETAILED DESCRIPTION

### FUNCTION

3.01 The function mechanism consists of a jack shaft with a gear for driving the main shaft. The main shaft assembly includes a clutch assembly and cams for actuating a rocker bail. The clutches differ in the two types of perforators in that the nontyping perforator has a two-stop clutch which stops twice during each revolution and performs its function in one half of

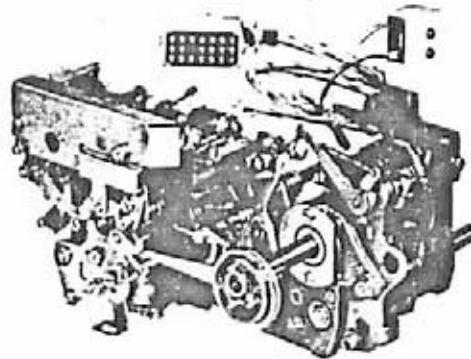

Figure 2 - Nontyping Perforator

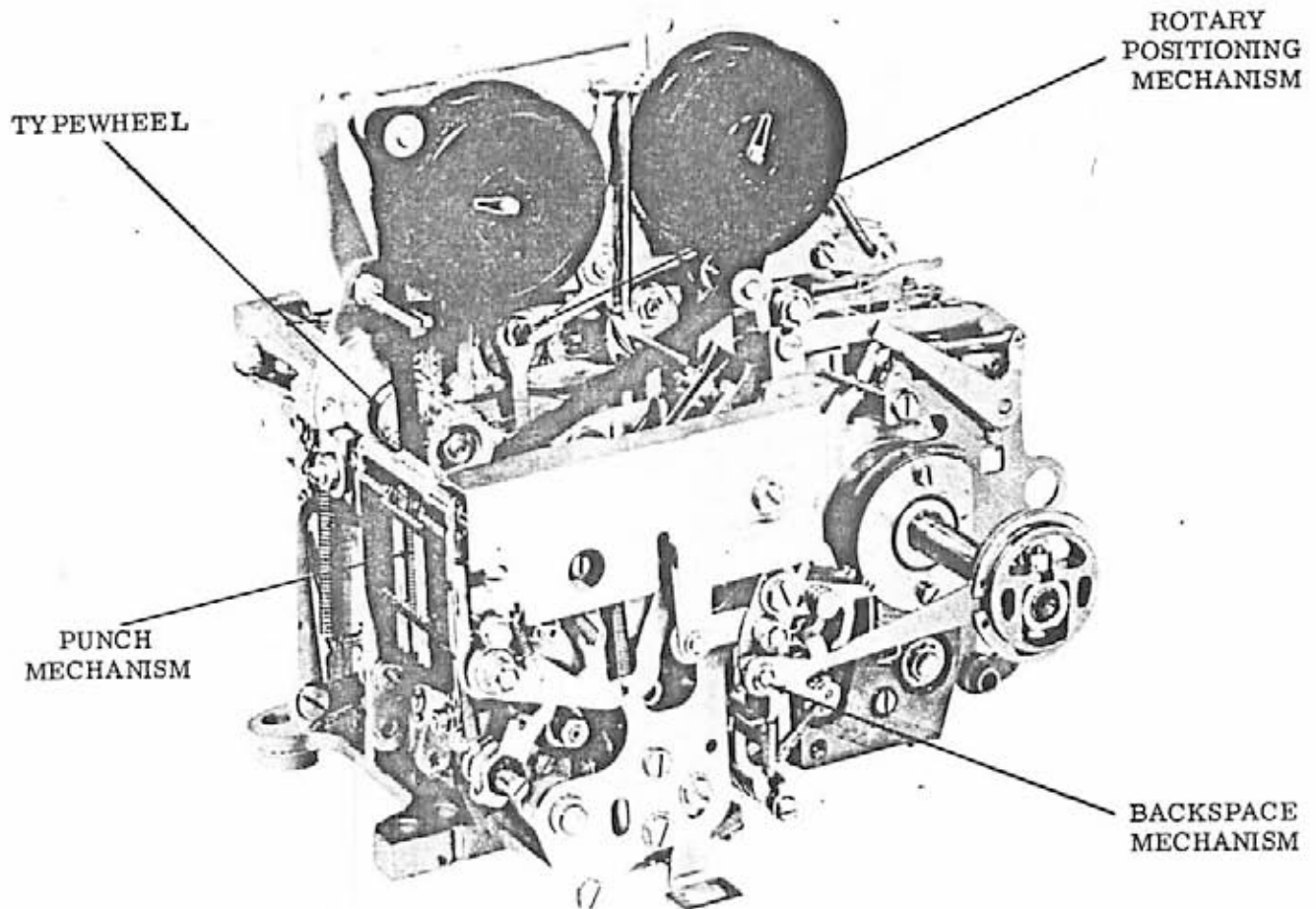

Figure 3 - Typing Perforator (Front View)

a revolution. This makes the nontyping perforator capable of operating twice as fast as a unit with a one-stop clutch. The typing perforator uses a one-stop clutch because the typing mechanism limits its speed of operation. The cams of the function shaft assembly are used to provide motion for the rocker bail, the main source of power for all functions except selection.

#### SELECTION

3.02 Selection is accomplished mechanically from an associated keyboard through its codebar extensions. An extension is positioned to operate each punch slide latch on the perforating mechanism when selection is made, and a perforator triplerver latch is in position to trip the perforator clutch when selection is applied at the keyboard.

#### PERFORATING

3.03 The perforator mechanism consists of a set of five punch slides, punch block assembly containing punch pins, toggle bail and reset bail assembly, and a tape feeding assembly. A perforator drive link connects the toggle bail and reset bail assembly to the rockerbail which provides motion for operation of the perforator mechanism.

#### TYPING

3.04 In addition to the function, selecting, and perforating mechanisms, the typing perforator encompasses other mechanisms necessary for printing on tape. The selection is passed through a transfer mechanism to a func-

tion box and pushbars which control a rotary positioning mechanism and an axial positioning mechanism to position a typewheel for printing. A correcting mechanism further corrects the positioning of the typewheel. A printing mechanism driven directly by the rocker bail actuates a print hammer after the typewheel has reached its correct position, and impels the print hammer upward to drive the tape and inked ribbon against the typewheel. A ribbon feed mechanism, which advances an inked ribbon one space during each operation, is actuated by the rocker bail through a ribbon drive arm.

VARIABLE FEATURES

3.05 Some variable features used with the perforators are: tape backspace mechanism, code reading contacts, and auxiliary contacts.

3.06 The tape backspace mechanism may be manually operated entirely on the perforator, or, with the addition of a magnet assembly on the perforator, it may be power operated from a keylever and switch assembly on a keyboard.

3.07 The code reading contacts are operated by the punch slides to read the code combinations which are being perforated.

3.08 The auxiliary timing contacts provide synchronizing pulses for the code reading contacts.

4. PRINCIPLES OF OPERATION

GENERAL

4.01 The general outline of operation of the two perforators is shown in the block diagram (Figure 6). The broken lines represent the nontyping perforator while the typing perforator is represented by both a broken line and solid line. Selection is applied from the keyboard. The main shaft of the perforator is continuously rotated by power from an associated motor and shafting on an associated keyboard base. The rotary motion is transferred from the main shaft through an all-steel internal expansion clutch to the function cam.

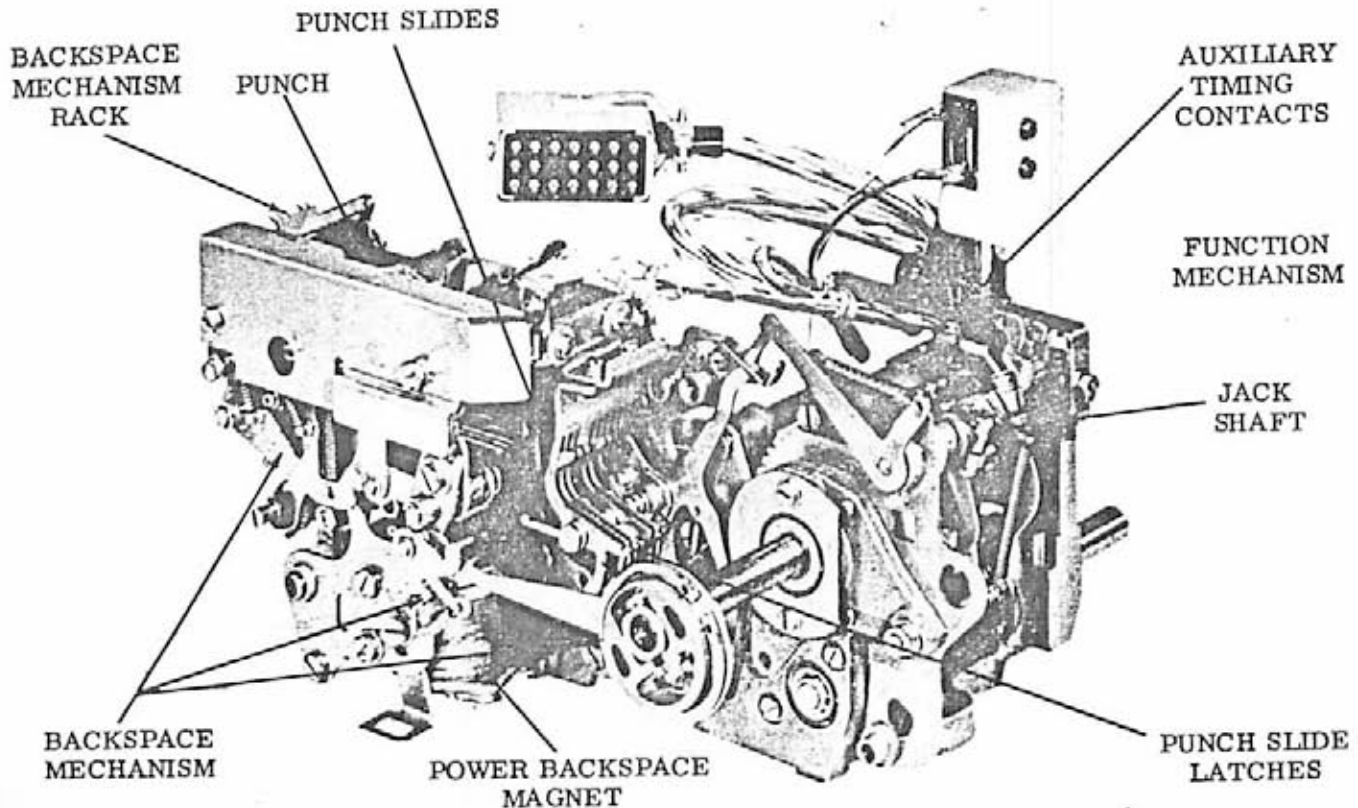

Figure 4 - Nontyping Perforator (Front View)



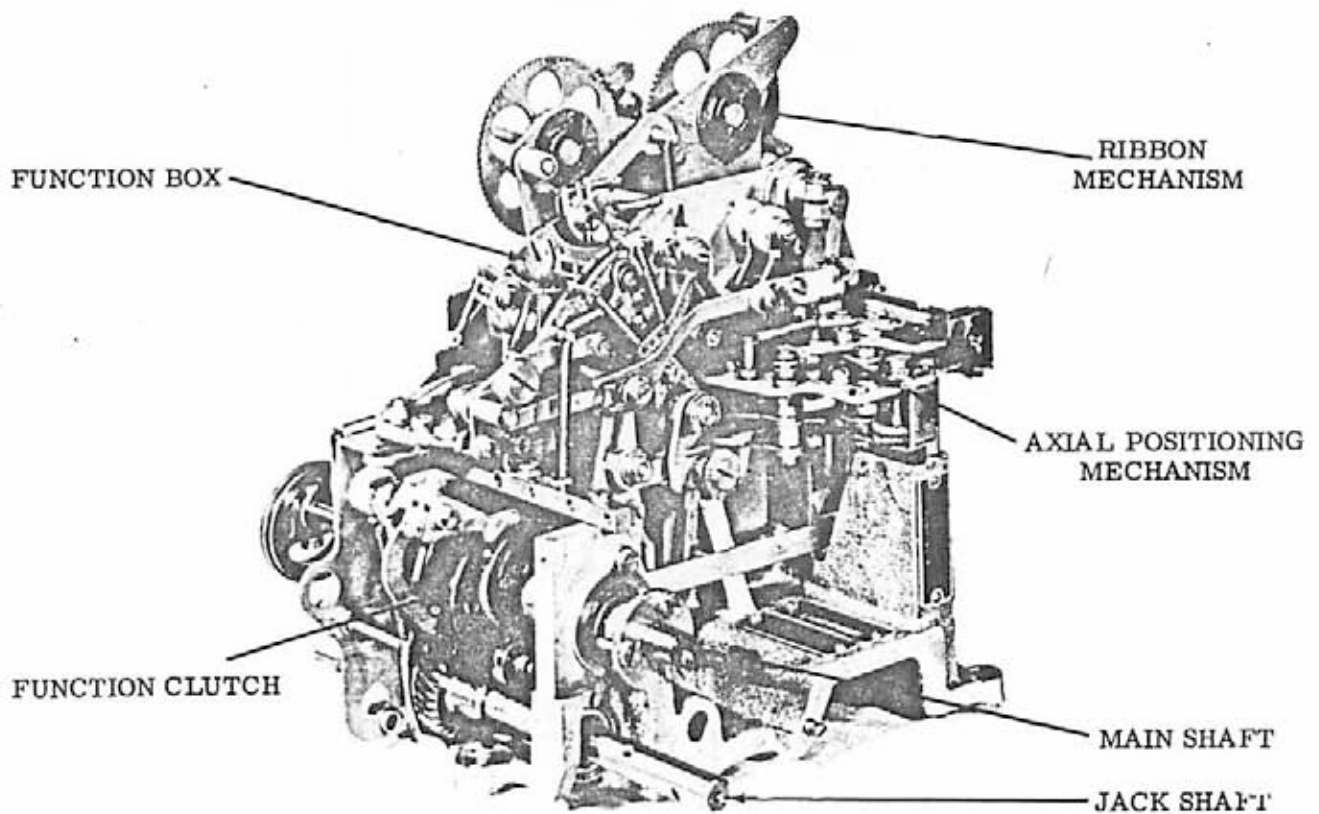

Figure 5 - Typing Perforator (Rear View)

4.02 The function cam drives a rocker bail to transfer the motion derived from the main shaft into simple harmonic motion which drives the other mechanisms of the unit.

#### SELECTION AND TRANSLATION

4.03 The code combinations set up by keylever on the keyboard are transferred through codebar extensions which move to the right and trip a punch slide latch for each marking condition of the code combination (Figure 7).

#### A. Clutch Operation

4.04 The typing perforator uses a one-stop function clutch, whereas the nontyping perforator uses a two-stop function clutch. The functions performed are essentially the same except that in the nontyping unit the function is performed during a one-half turn of the main shaft and therefore is capable of operating twice as fast as the typing unit. The typing unit is limited to a slower speed because of the typing operation performed. The operating principle of the internal mechanisms are the same except

two shoe levers are used to disengage the clutch twice for each revolution of the clutch in the nontyping perforator.

#### One-Stop Clutch Operation (Figures 8 and 9)

4.05 The clutch drum is attached to and rotates in unison with the main shaft. In the disengaged position, as shown in Figure 9, the clutch shoes do not contact the drum, and the shoes and cam disc are held stationary. Engagement is accomplished by moving the clutch trip lever, Figure 12, away from the clutch and thus releasing stop lug A and the lower end of shoe lever B (Figure 8). The upper end of lever B pivots about its ear C, which bears against the upper end of the secondary shoe, and moves its ear D and the upper end of the primary shoe toward the left until the shoe makes contact with the notched inner surface of the rotating drum at point E. As the drum turns counterclockwise, it drives the primary shoe downward so that it again makes contact with the drum at point F. There, the combined forces acting on the primary shoe cause it to push against the secondary shoe

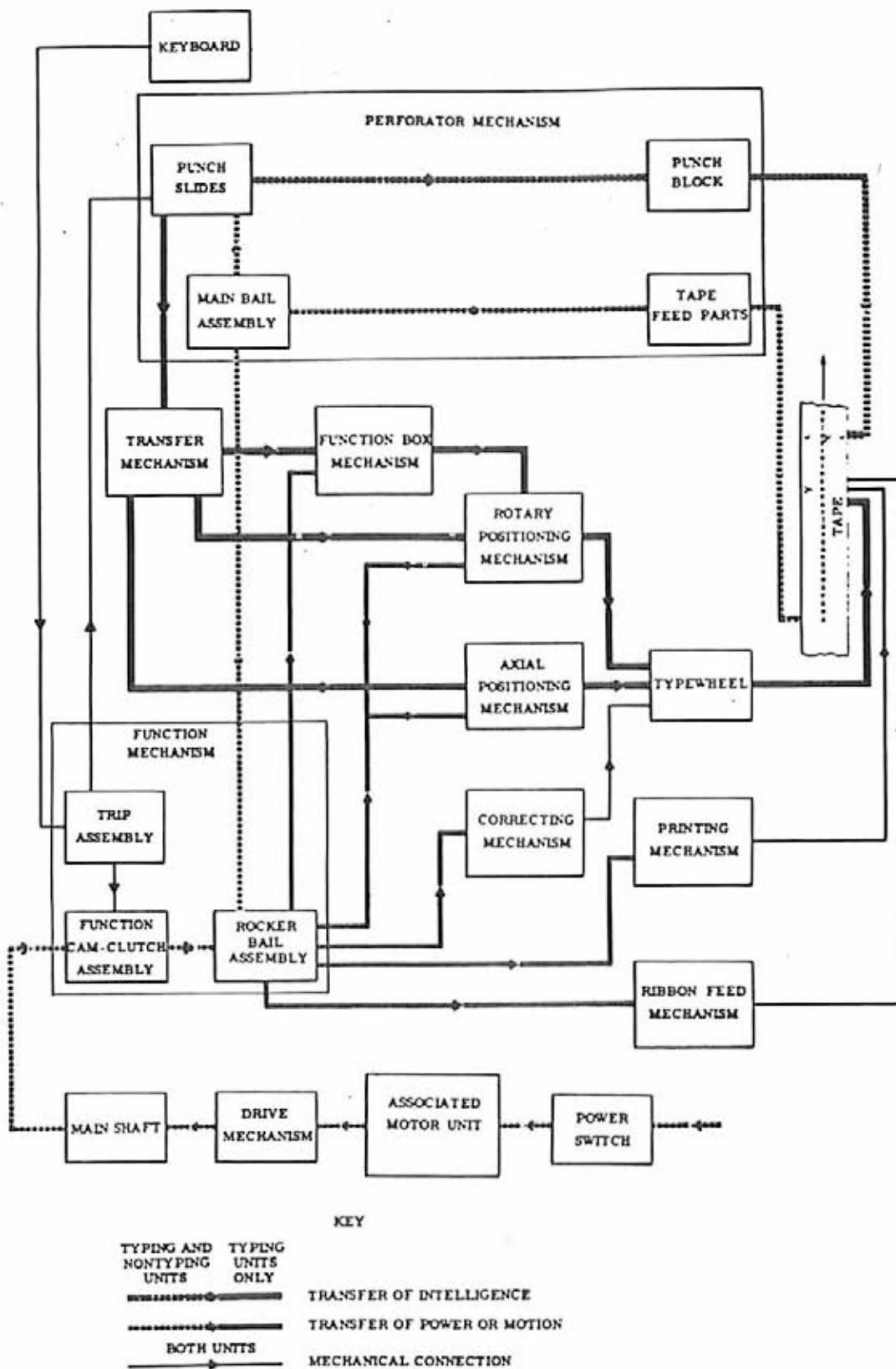

Figure 6 - Block Diagram for Typing and Nontyping Perforators

at point G. The lever end of the secondary shoe then bears against the drum at point H. The drum drives this shoe upward so that it again makes contact with the drum at point I. The forces involved are multiplied at each of the preceding steps. The aggregate force is applied through the shoes to the lug J on the clutch cam disc, and the disc and attached cam turn in unison with the drum.

4.06 Disengagement is effected when the lower end of shoe lever B strikes the clutch trip lever. Lug A and the lower end of the shoe lever are brought together (Figure 8), and the upper end of lever B pivots about its ear C and allows its other ear D to move toward the right. The upper spring then pulls the two shoes together and away from the drum. The latch lever seats in the indent in the cam disc and the cam is held in its stop position until the clutch is again engaged.

Two-Stop Clutch Operation (Figure 10).

4.07 The operation of the two-stop clutch, which is used exclusively on the function cam clutch of the two-shaft unit, is similar to that of the one-stop clutch, the major difference being that it can be stopped after 180 degrees of rotation rather than 360 degrees. The two-stop clutch is shown disengaged in Figure 10. When the stop arm is moved away from A, the shoe lever disc under spring tension pivots counterclockwise and carries with it the shoe lever which engages the shoe lever disc at B. The shoe lever moves the primary shoe to the left and engagement is completed as described in Paragraphs 4.05 and 4.06. After the cam clutch rotates 180 degrees, the shoe lever disc strikes the stop arm at A'. The shoe lever disc and shoe lever are pivoted clockwise and the clutch is disengaged as outlined in Paragraph 4.06.

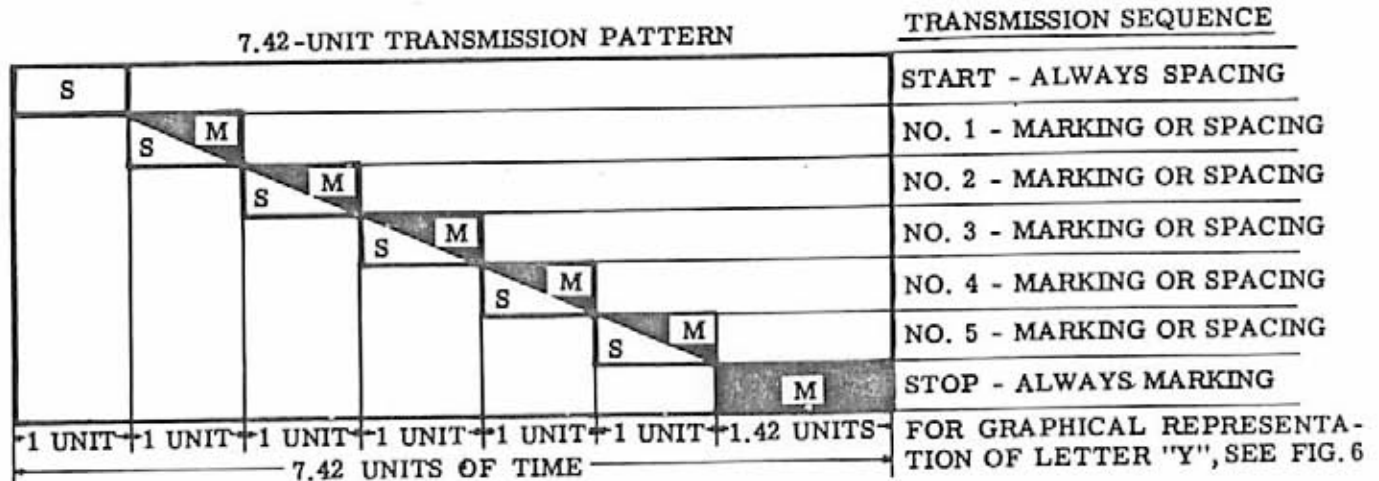

FIGURES	-	?	:	\$	3	!	B	#	B	'	(	)	.	,	9	ø	l	4	Δ	5	7	:	2	/	6	*	z	<	≡	■	V	Λ		
LETTERS	A	B	C	D	E	F	G	H	I	J	K	L	M	N	O	P	Q	R	S	T	U	V	W	X	Y	Z	BLANK	C.R.	L.F.	SPACE	LTR	FIG.		
1	●	●		●	●	●				●	●									●	●	●	●	●	●	●						●	●	
2	●		●				●		●	●	●	●				●	●	●			●	●	●								●	●	●	
FEED HOLES	○	○	○	○	○	○	○	○	○	○	○	○	○	○	○	○	○	○	○	○	○	○	○	○	○	○	○	○	○	○	○	○	○	○
3			●		●	●	●	●	●	●	●	●	●	●	●	●	●	●	●	●	●	●	●	●	●	●	●	●	●	●	●	●	●	●
4		●	●	●	●	●	●	●	●	●	●	●	●	●	●	●	●	●	●	●	●	●	●	●	●	●	●	●	●	●	●	●	●	●
5	●						●	●			●	●	●	●	●	●	●	●	●	●	●	●	●	●	●	●	●	●	●	●	●	●	●	●

(TYPICAL CHARACTER ARRANGEMENT)

Figure 7 - Code Chart

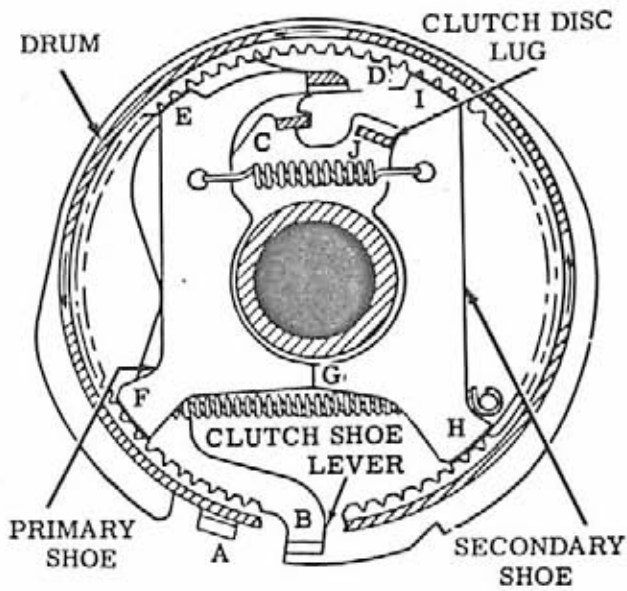

Figure 8 - One-Stop Clutch (Engaged)

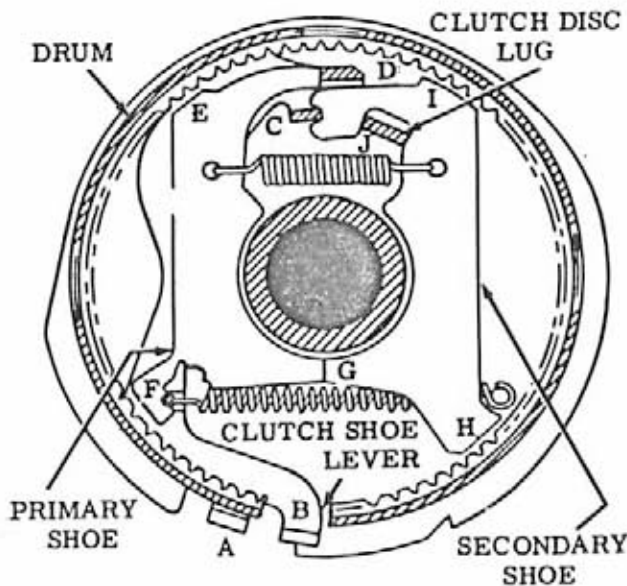

Figure 9 - One-Stop Clutch (Disengaged)

B. Transfer

4.08 Near the end of selection, the transfer mechanism moves the intelligence in the form of a mechanical arrangement from the punch slides to the function box and positioning mechanisms. Included in the mechanism are five linkages, each of which is associated with a punch slide. A linkage consists of a transfer lever, a pulse beam and a bell crank. Since the linkages are similar, only the no. 4 is shown in its entirety in Figure 11.

4.09 The linkages associated with the unselected punch slides remain in their unselected position as in Figures 11 and 12. However, the selected slides in moving to the left, pivot the associated transfer levers which, in turn, move corresponding pulse beams clockwise (as viewed from above). The selected beams allow associated bell cranks under spring tension to pivot counterclockwise and lift attached pushbars. The pushbars, in turn, control the positioning mechanisms. In the period of the last half of the function cycle, the selected slides are moved back to the right (4.46) and return the linkages to their unselected position.

4.10 Slotted upper arms of the bell cranks extend up into the function box and control its operation as described in Paragraph 4.34. An additional bell crank, not associated with a transfer linkage, is specifically concerned with the letters-figures shift.

MOTION FOR TYPING AND PERFORATING

A. General

4.11 The motion of the main shaft is conveyed to the mechanisms concerned with typing and perforation by the function mechanism, which is comprised of a cam clutch, a clutch trip assembly (Figure 12) and a rocker bail (Figures 13 and 14).

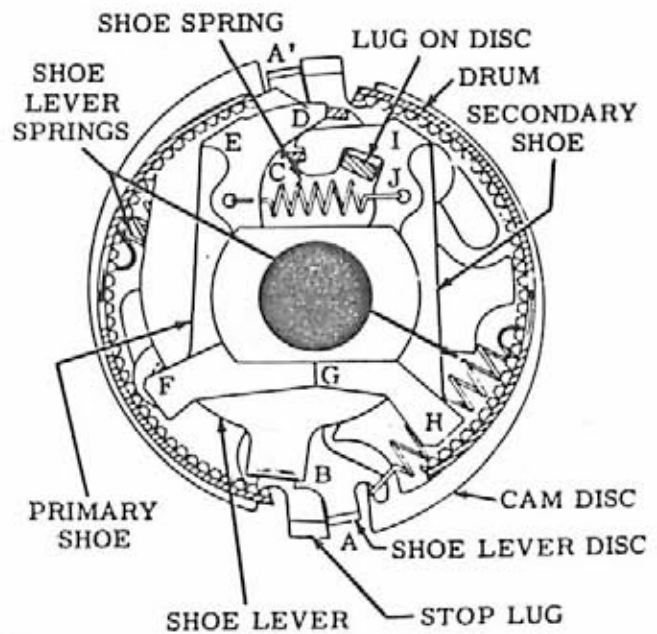

Figure 10 - Two-Stop Clutch

## B. Function Cam Clutch and Clutch Trip Assembly

4.12 The trip assembly is shown in its unoperated condition in Figure 12. Through codebar extensions and a clutch trip bar link, Figure 12, operation of a keylever on an associated keyboard releases the punch slide latches and trips the function clutch. A perforator trip lever latch is positioned underneath an extension of the perforator trip lever. When a keylever is operated, the perforator trip lever latch rotates a main trip lever counterclockwise. A reset bail trip lever attached to the main trip lever lowers the perforator reset bail and releases the punch slides (4.43); and an upper arm of the main trip lever moves out of the way of a clutch release, which falls against a down-stop and rotates a trip shaft counterclockwise. Immediately, the perforator trip lever latch returns to its unoperated position, and the upper arm of the main trip lever moves down against the release. When the trip shaft is rotated by the release, it moves an attached clutch trip lever out of engagement with the clutch shoe lever. The clutch engages, and the cam clutch begins its cycle. The internal operation of the clutch is the same as that in Paragraph 4.05.

4.13 About midway through the function cycle, an eccentric pin on the function cam lifts a reset arm, which rotates the trip shaft clockwise. The release is moved up and allows the main trip lever to raise the reset bail as it moves to its downstop. The pin on the reset cam then moves out from under the reset arm, and the release is permitted to return to its unoperated position against the main trip lever. When the clutch completes its cycle, the clutch shoe lever strikes the trip lever, and the clutch disengages.

## C. Rocker Bail (Figures 13 and 14)

4.14 The function cams and the rocker bail translate the rotation of the main shaft into simple harmonic motion, which the rocker bail distributes to the operating mechanisms of the unit.

4.15 Since the nontyping perforator operates only the mechanism for perforating tape, a different rocker bail is used to drive the punch mechanism only (Figure 14).

4.16 The rocker bail, used in the typing perforator, includes two upward extensions which transfer the harmonic motion to:

- (a) Ribbon feed mechanism
- (b) Perforator
- (c) Correcting mechanism
- (d) Function box
- (e) Printing mechanism

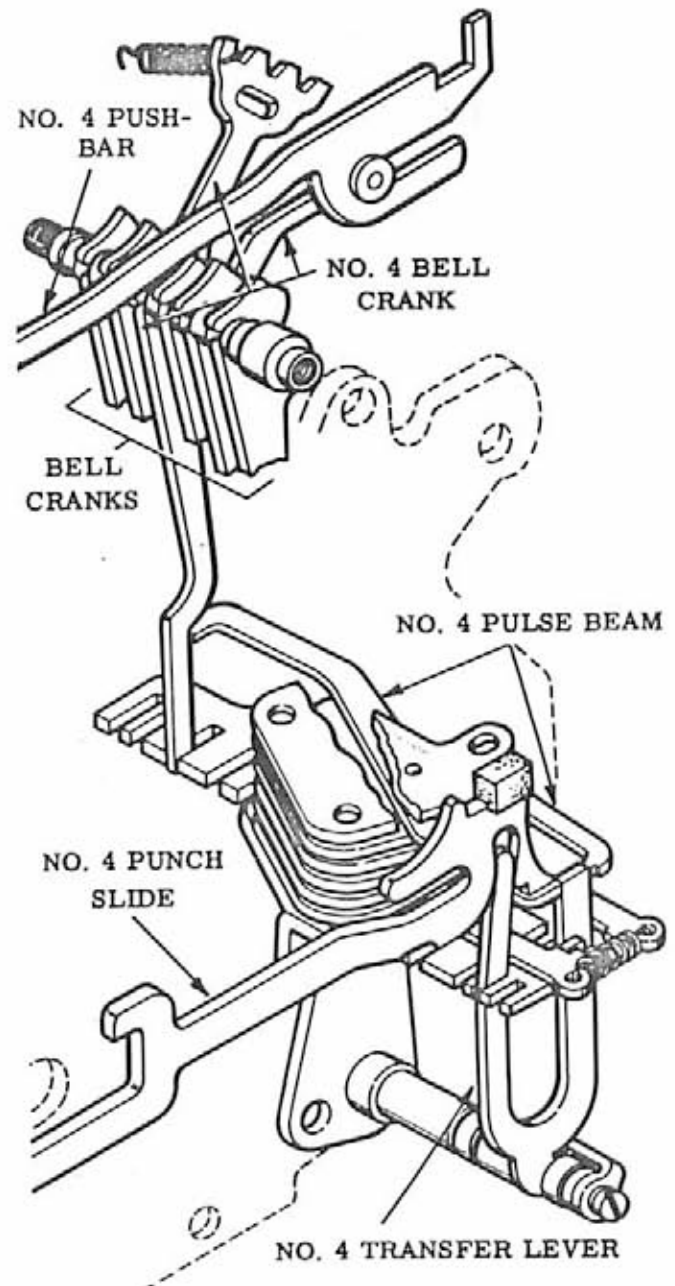

Figure 11 - Transfer Mechanism

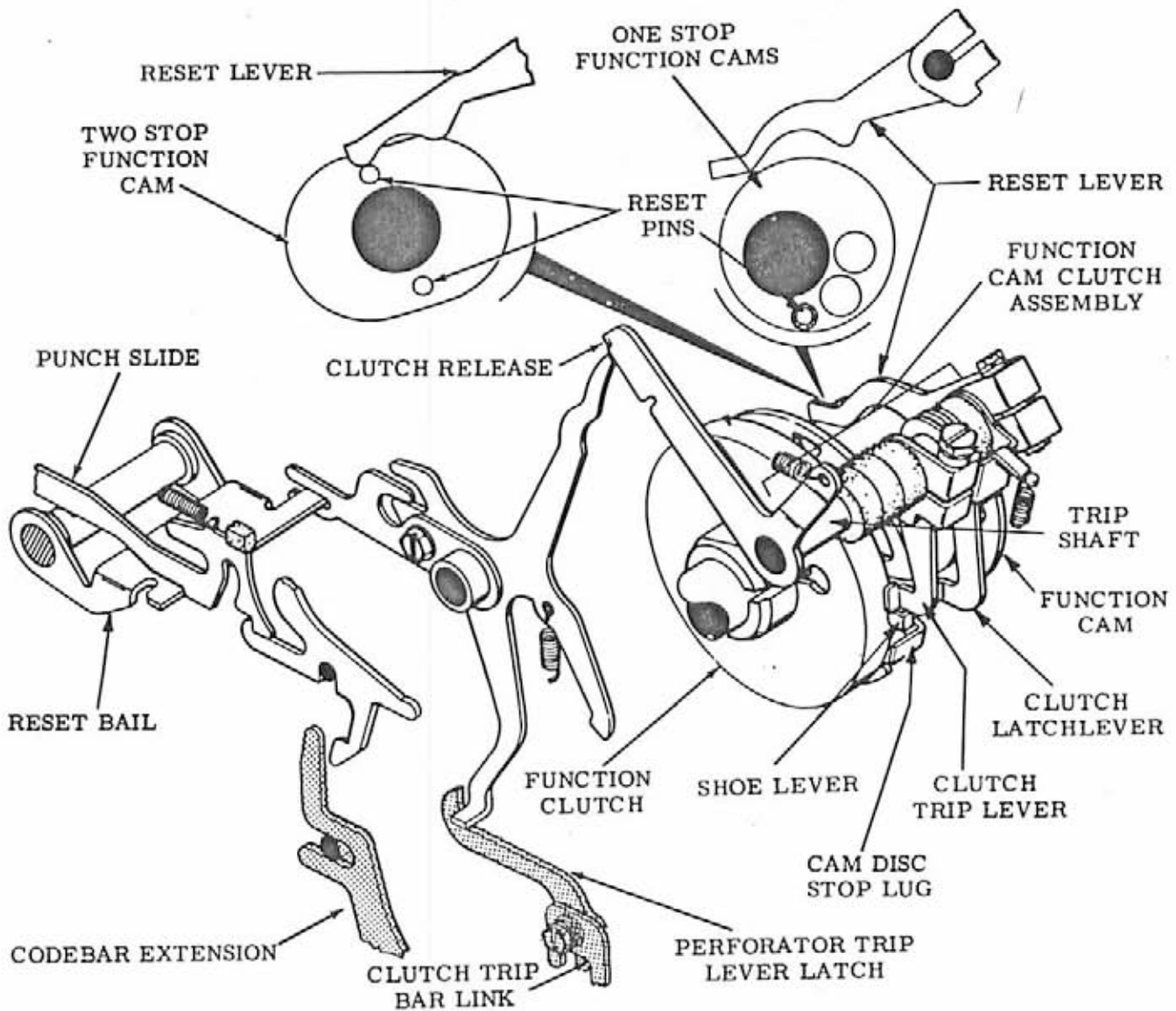

Figure 12 - Function Cam Clutch and Clutch Trip Assembly

- (f) Oscillating assembly
- (g) Pushbars of the axial and rotary positioning mechanisms

The bail is shown in its home position in Figure 13. Through each function cycle, the function cams bear against the rollers and cause the bail to rock to the right (as viewed from the rear in Figure 14) during the first half of the cycle and then back to the home position during the latter part of the cycle.

TYPING

A. General

4.17 The characters used to type the received intelligence - letters, figures, and symbols representing various functions - are embossed on the cylindrical surface of the metal typewheel (Figure 15). During the function cycle, the axial and rotary positioning mechanisms (Figures 16 and 18), having received the intelli-

gence from the transfer mechanism, position the wheel so that the character represented by the received code combination is selected. Following typewheel positioning the correcting mechanism (Figures 16 and 18) accurately aligns the selected character. Then the printing mechanism (Figure 20), by means of a hammer, drives the tape and inked ribbon against the wheel and imprints the character. A ribbon feed mechanism (Figure 21) advances the ribbon and reverses its direction of feed when one of two ribbon spools is depleted. Near the end of the function cycle the axial positioning mechanism retracts the typewheel and a ribbon guide so that the last printed character is visible. The letters or the figures code combination sets up an arrangement in the transfer mechanism which permits the function box (Figure 19) to operate and cause the rotary positioning mechanism to shift the typewheel through 180 degrees of rotation.

## B. Typewheel Positioning

### General

4.18 A typical typewheel character arrangement is shown in Figure 15 in which the wheel's cylindrical surface is shown rolled out into a plane. There are 16 longitudinal rows, each of which is made up of four characters numbered 0 to 4 from front to rear. The surface is divided into two sections, a letters and a figures, each containing eight rows. The fifth row counterclockwise from the division line in both sections is numbered 0. There are four rows in one direction from 0 numbered 1 to 4 and designated as counterclockwise rows, and three rows in the other direction numbered 1 to 3, designated as clockwise rows. It should be noted that the clockwise and counterclockwise modifiers refer to the direction of rotation of the wheel to select the rows and not to their position on the wheel.

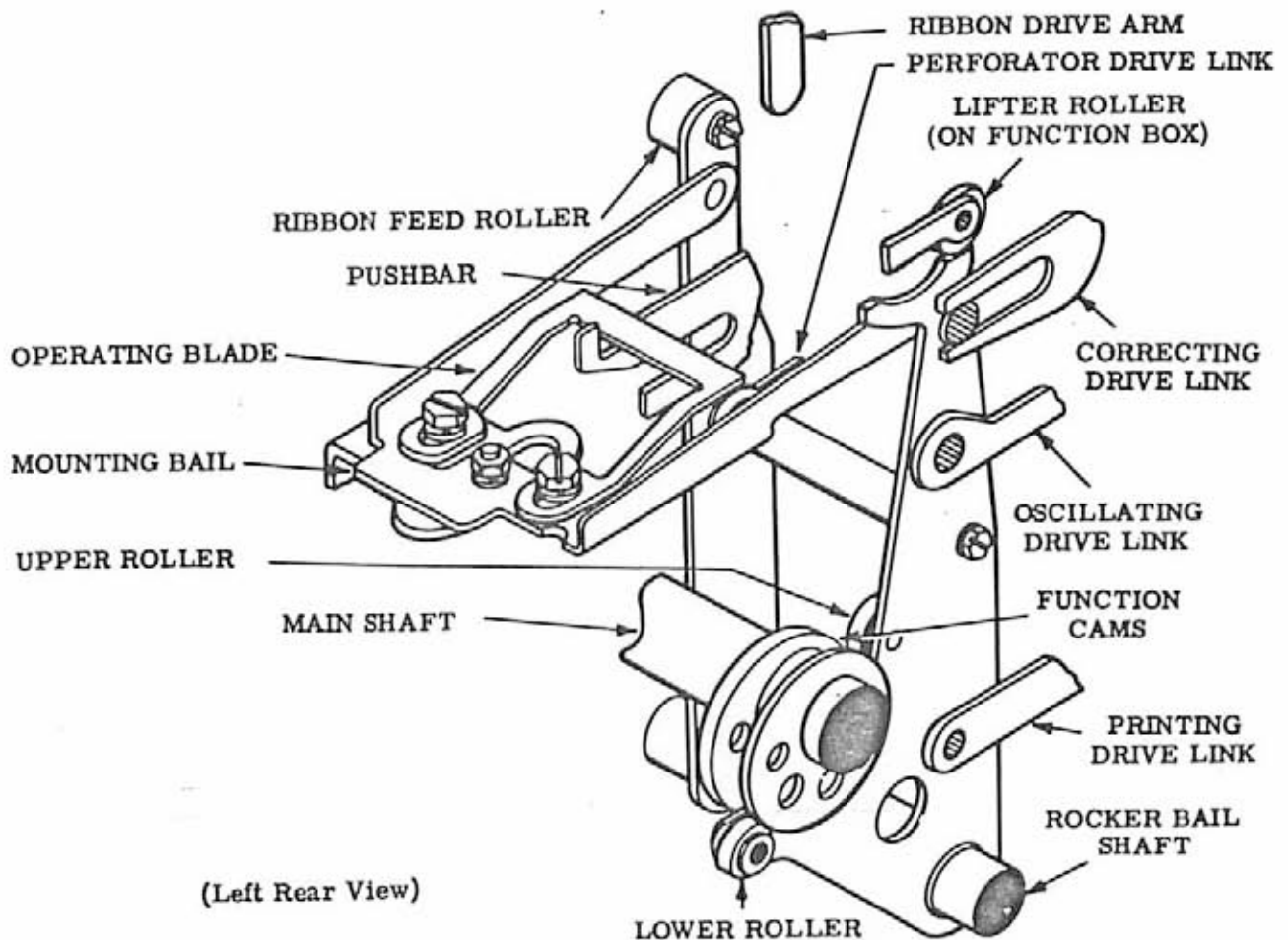

Figure 13 - Typing Perforator Rocker Bail Assembly

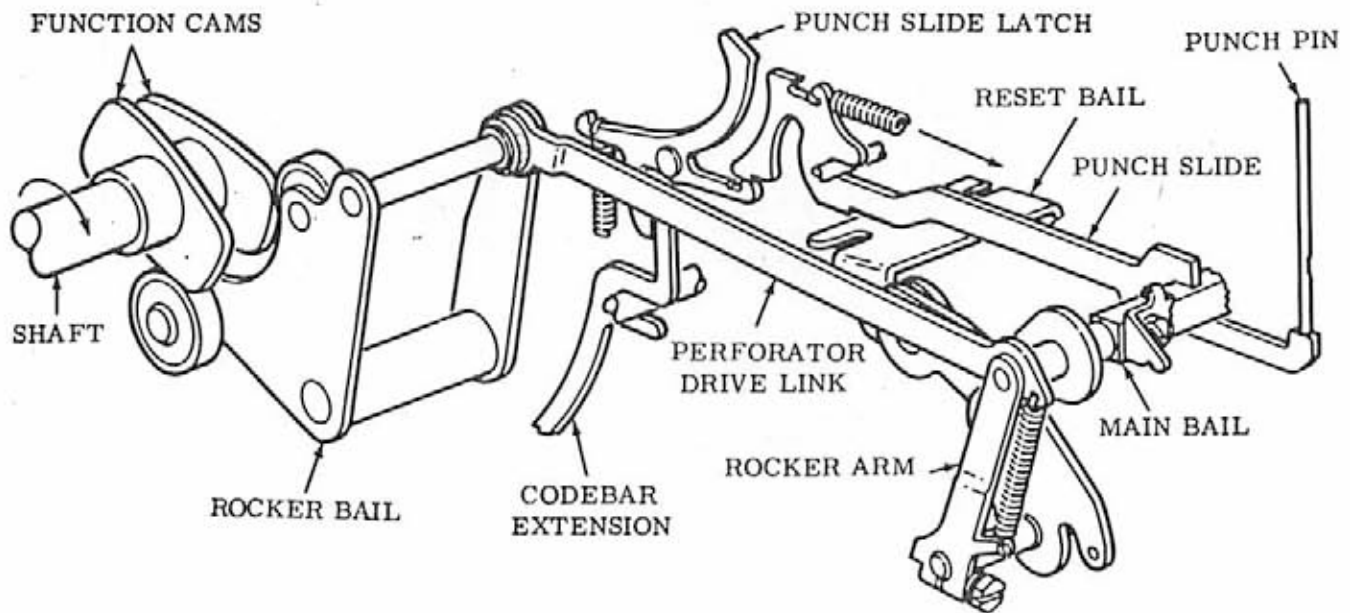

Figure 14 - Nontyping Perforator Rocker Bail

4.19 Each printing operation (excluding those devoted to the letters-figures shift) begins and ends with the typewheel in the home position of the section containing the character to be printed, ie, with the no. 0 character of the no. 0 row at the point of contact of the print hammer. (Actually, inasmuch as the wheel is retracted to show the last printed character (4.27), the no. 0 character is slightly to the rear, but for this discussion it will be assumed that it is at the point of contact.) During the printing operation the axial and rotary positioning mechanisms, transferring separate but simultaneous motions to the wheel, position it so that the character represented by the received code combination is at the point of contact of the hammer at the time of printing. The rotary mechanism, which is controlled by the no. 3, 4 and 5 selecting elements of the code, revolves the wheel so as to select the proper row; and the axial mechanism, which is governed by the no. 1 and 2 elements, moves it forward and rearward along its axis so as to select the proper character in the row. Rotation of the typewheel to print in either the letters or the figures section is controlled by the no. 7 element of the code. The letters-figures shift (4.33), which consists of rotating the wheel eight rows from the home position of one section to that of the other, requires a separate operation of the equipment and results in the printing of the letters or figures symbol.

4.20 To illustrate the above, if the wheel is in the figures condition, as shown in Figure 16, and the numeral "5" is to be printed, there is no movement of the wheel during the printing operation, because "5" is already at the point of contact of the hammer. However, if the letter "I" is to be printed, the signaling code for letters must first be viewed to shift the typewheel eight rows to the letters home position. Then during the next operation it is rotated three rows counterclockwise and moved forward two characters so that "I" is at the point of contact of the hammer. Printing takes place, and the wheel is then returned to the letters home position.

#### Rotary Positioning (Figures 16 and 17)

4.21 The rotary positioning mechanism revolves the typewheel so that the row containing the character to be printed is aligned with the print hammer at the time of printing. Mounted on the front plate, the mechanism includes two eccentric assemblies as shown in Figures 16 and 17. Each assembly includes a primary shaft, a section of which is formed into a pinion. A secondary shaft, mounted in the primary and offset from its center, forms an eccentric, referred to as the rear eccentric. A portion of the secondary shaft is also a pinion, and a crank pin mounted on its disc-like forward surface forms a secondary, or front, eccentric. Each of the four pinions of the two



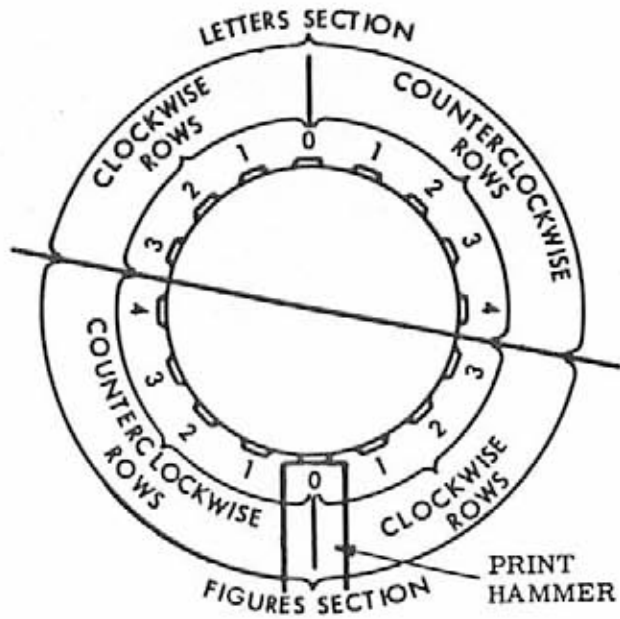

A. FRONT VIEW SHOWING 16 LONGITUDINAL ROWS

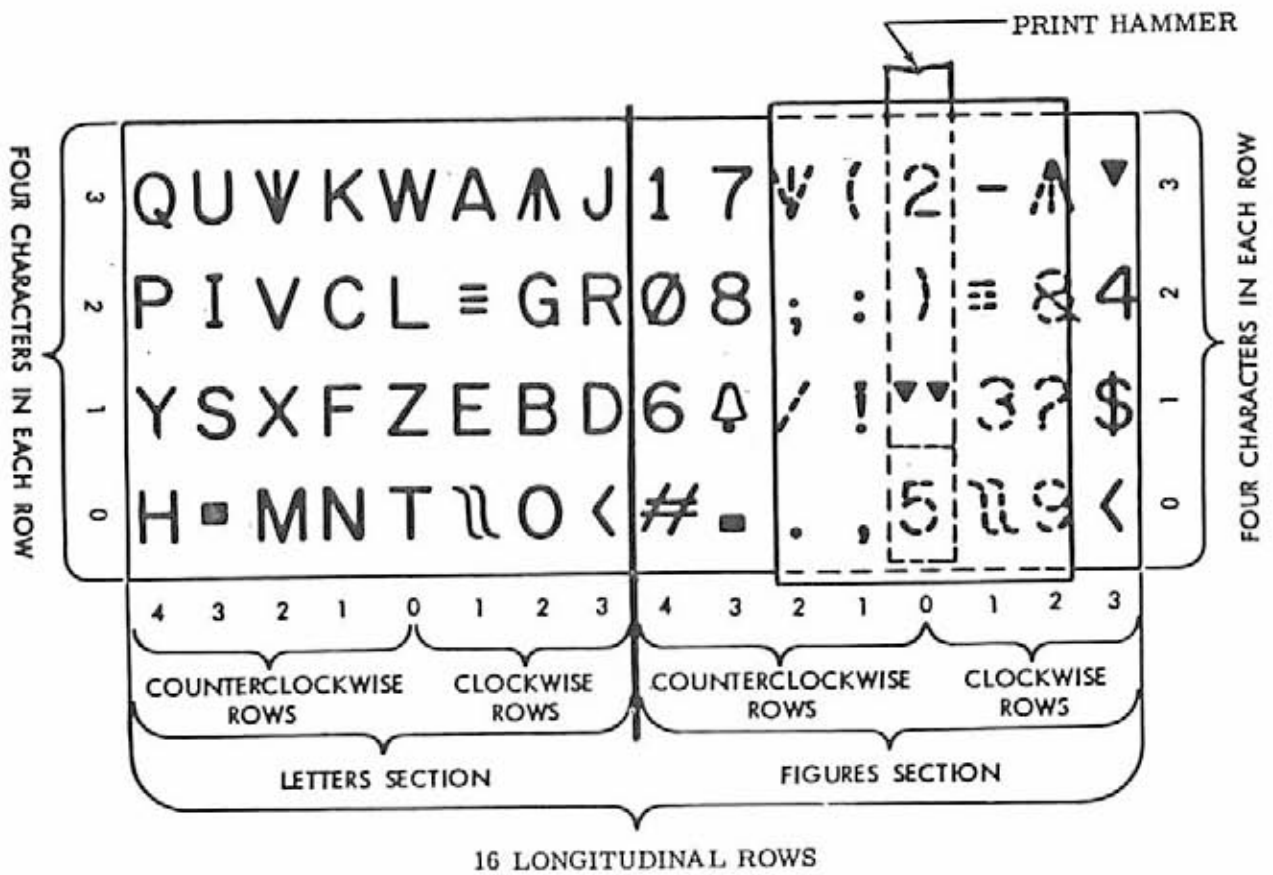

B. TOP VIEW SHOWING CYLINDRICAL SURFACE IN A PLANE

Figure 15 - Typical Typewheel Character Arrangement

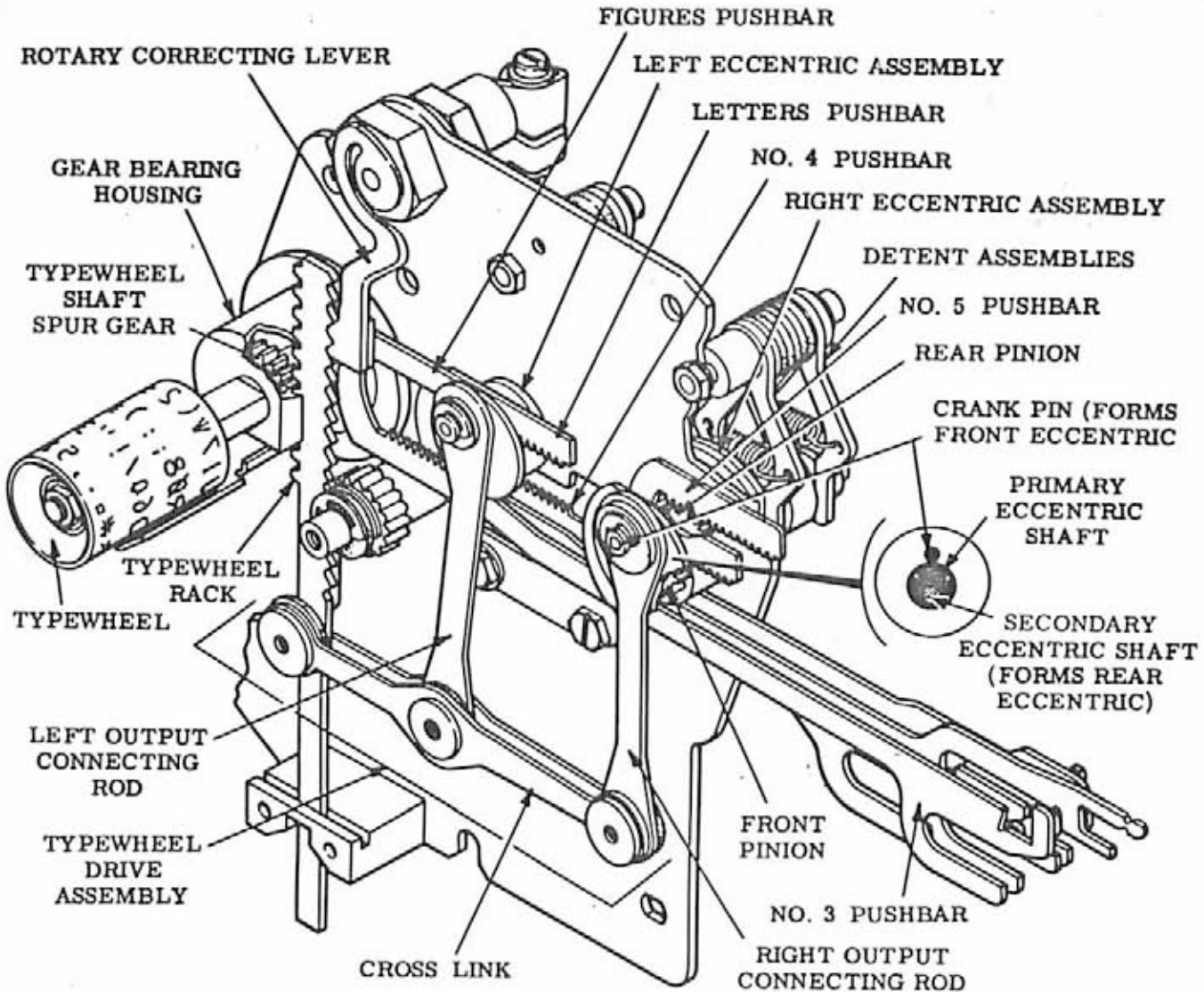

Figure 16 - Rotary Positioning Mechanism

eccentric assemblies is engaged by the rack of a pushbar: the no. 3 bar engages the rear pinion, and the no. 5 engages the right pinion. The left front pinion is engaged by both the letters and the figures pushbar.

4.22 The eccentric assemblies are linked to a typewheel shaft by a drive assembly as shown in Figure 16. The typewheel is secured to the front of the shaft which is supported by a bearing housing mounted at the left rear of the front plate (Figure 18). A spur gear which meshes with a typewheel rack rides on the shaft in a bearing housing. The shaft is free to move axially in the housings and the spur gear, but flats in its circumference which bear against flats in the gear ensure its rotating when the gear rotates.

4.23 When in response to a marking pulse a pushbar is lifted by its bell crank, as described in 4.07, the rocker bail operating blade (see Figures 14 and 17) engages a slot in the bar and moves it to the left during the first part of the function cycle. The bar, by means of its rack and the mating pinion, rotates the associated eccentric one-half revolution where it is locked in position by a detent assembly while printing takes place. When the bail rocks back to the right during the latter part of the cycle, it returns the bar and eccentric to their home positions where the eccentric is again detented. The preceding does not apply to the no. 5 pushbar which is designed so that it is selected - moved to the left - on spacing rather than on marking, nor to the left front eccentric which

affects the letters-figures shift (4.33). In both assemblies one-half revolution of the rear eccentric results in its maximum vertical displacement which is transferred through the front eccentric to a crank pin. Similarly, one-half revolution of the front eccentric results in its maximum displacement being transferred to the crank pin. If both eccentrics are rotated, the displacement of the crank pin is equal to the algebraic sum of the two displacements which may be in either the same or opposite directions. Both assemblies are so designed that, if the displacement of the rear eccentric is taken to be one unit, the displacement of the front eccentric is four units. Four permutations are thus available: zero (neither eccentric displaced), one unit (rear eccentric displaced), four units (front eccentric displaced), and five or three units depending on how the assembly is set up (both eccentrics displaced).

4.24 In the right assembly the home position of the rear eccentric is down and the home position of front eccentric is up (Figure 17). Thus their displacements are in opposite directions - up for the rear and down for the front - and their aggregate displacement is three units downward. Any displacement occurring in the right assembly is imparted to the typewheel rack in equal quantity but opposite direction. For example, if the no. 5 pushbar is selected, it causes the right rear eccentric to be displaced, and one unit of upward motion is transferred through a right output connecting rod to the right end of a cross link (Figure 16). The cross link pivots about a left output connecting rod and at its left end imparts one unit of downward displacement to the typewheel rack. The rack rotates the spur gear, shaft and typewheel one row of characters clockwise from the home position, and the no. 1 clockwise row (Figure 15)

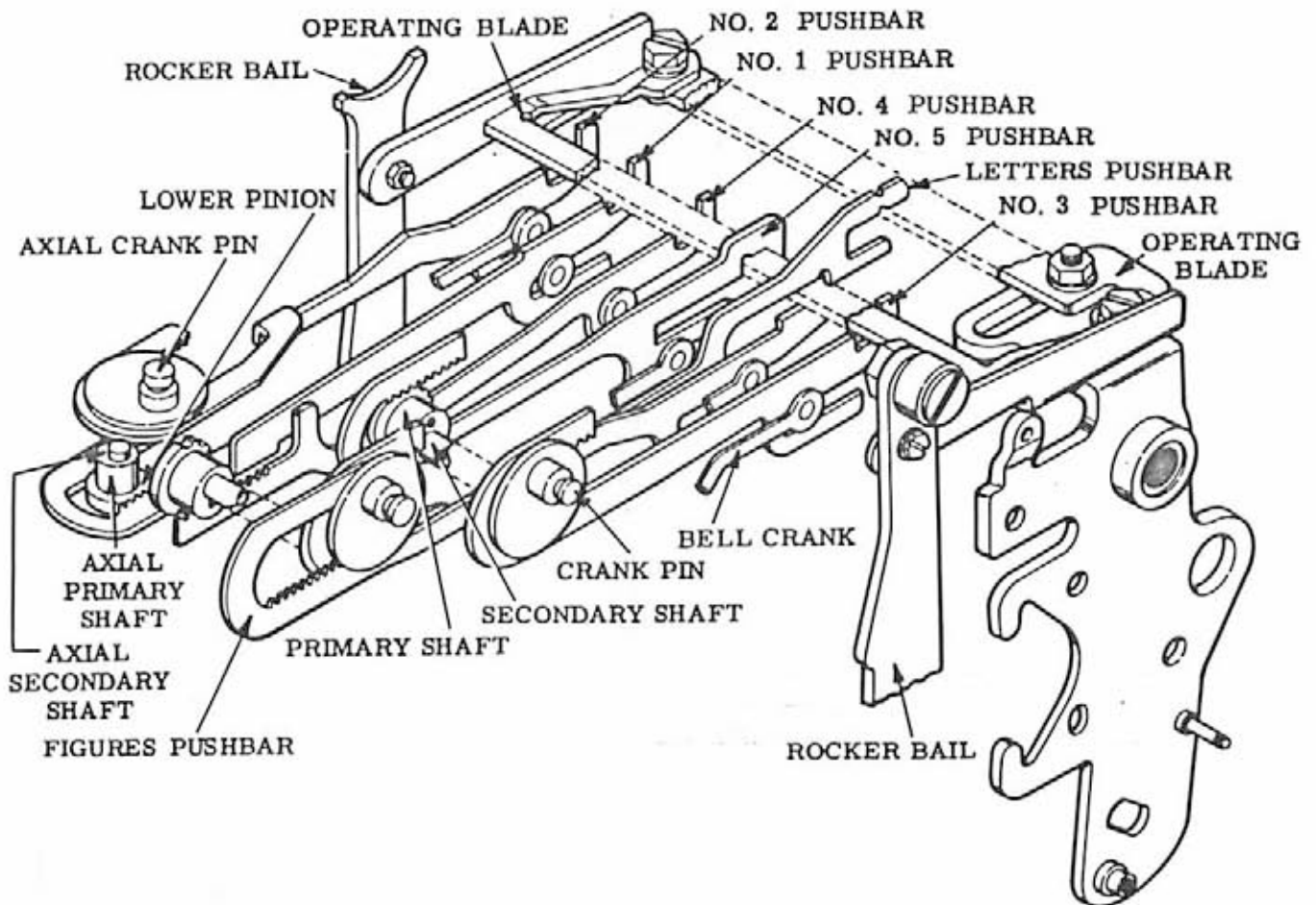

Figure 17 - Pushbars and Eccentric Assemblies

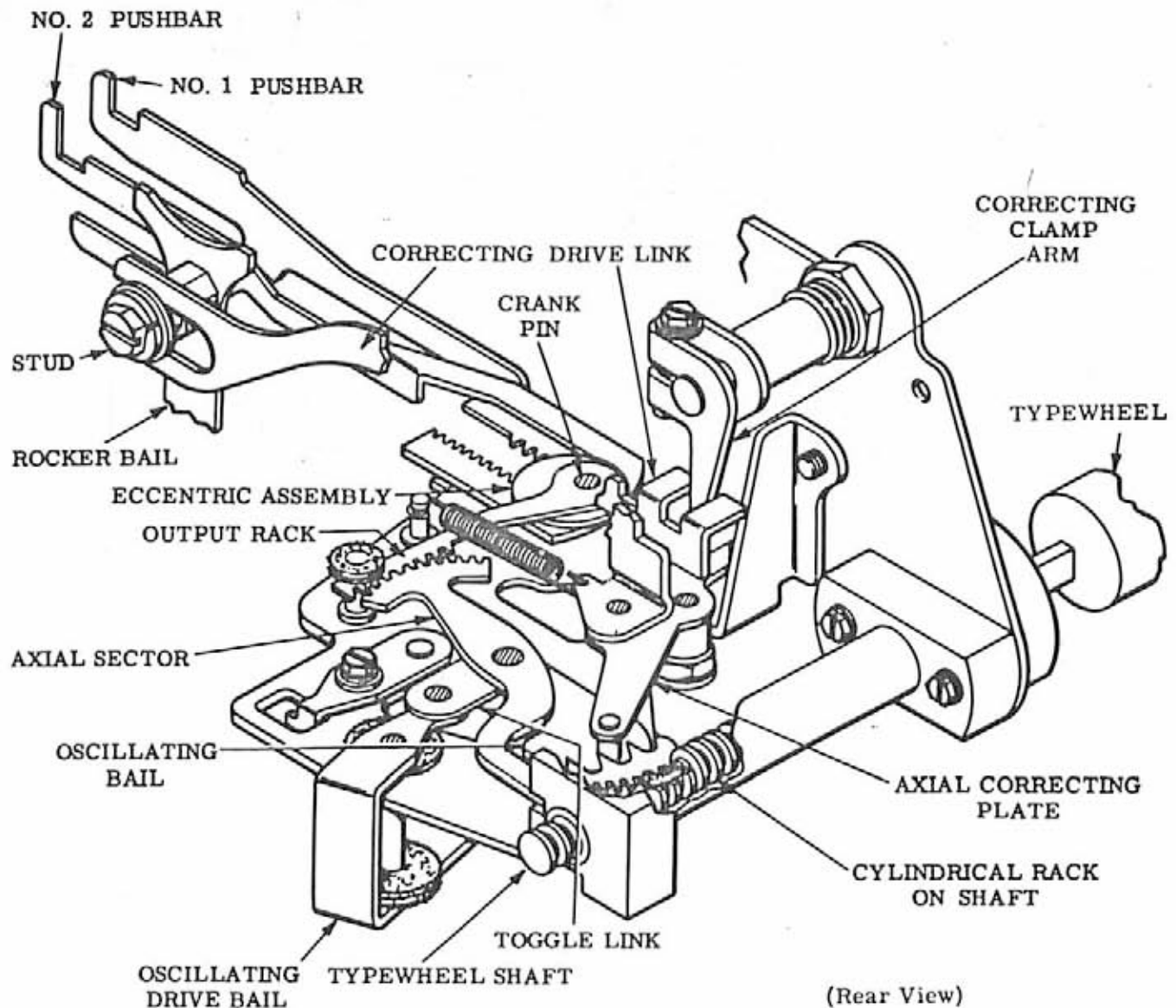

Figure 18 - Axial Positioning Mechanism

is presented to the print hammer at the time of printing. On its right stroke the no. 5 pushbar returns the eccentric and the typewheel to their home positions. In a similar manner, selection of the no. 3 pushbar results in a four unit downward displacement of the right front eccentric and a four-row, counterclockwise rotation of the typewheel. Selection of both the three and five type bars results in a three-row, counterclockwise rotation of the typewheel.

4.25 The home position of the left rear eccentric is up, and any displacement appearing in the left assembly is transferred to the typewheel rack in double quantity in the

same direction. When the no. 5 pushbar is selected, the left rear eccentric is displaced one unit downward. This movement is conveyed through the left output connecting rod to the approximate midpoint of the cross link. The cross link pivots about the right output connecting rod and its left end imparts two units of downward movement to the typewheel rack which rotates the typewheel two rows clockwise from its home position.

4.26 When both eccentric assemblies are displaced, the motion occurring in the typewheel rack is equal to the algebraic sum of the motions resulting from each assembly. For ex-

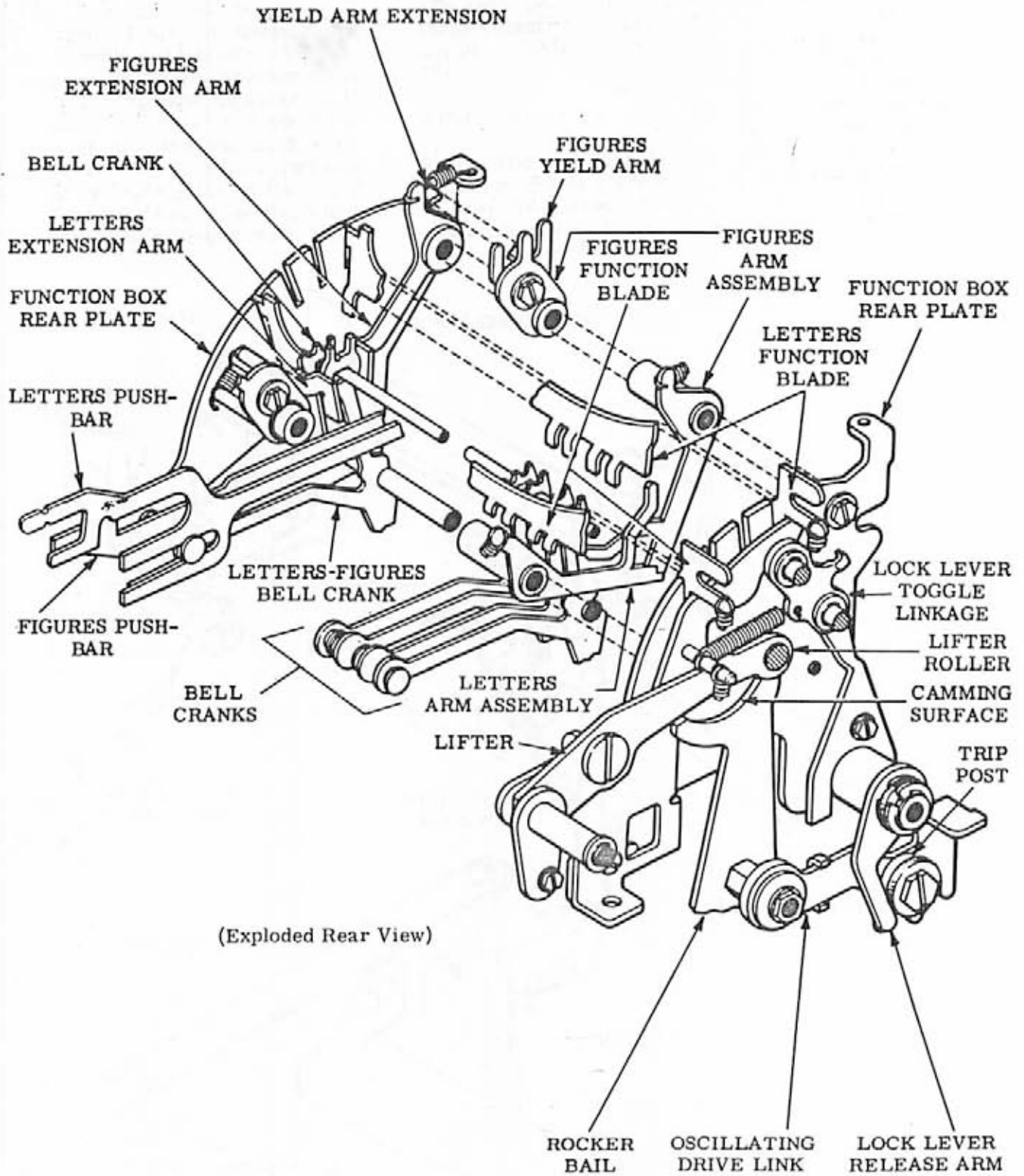

Figure 19 - Function Box

ample, if the no. 3, 4 and 5 pushbars are all selected, three units of upward displacement from the right assembly and two units of downward displacement from the left assembly occur as one unit ( $3-2 = 1$ ) of upward displacement in the rack and a counterclockwise rotation of one row in the typewheel. If neither the no. 3, 4 nor 5 pushbar is selected, the mechanism remains inactive and printing takes place in the no. 0 row. Excluding the left front eccentric, which is only used for the letters-figures shift, there

are eight permutations available in the other three eccentrics, making it possible to select any of the eight rows in a given section (Figure 15).

#### Axial Positioning (Figures 17, 18 and 20)

4.27 The functions of the axial positioning mechanism are to position the typewheel so that the proper character in the selected row is aligned with the hammer at the time of

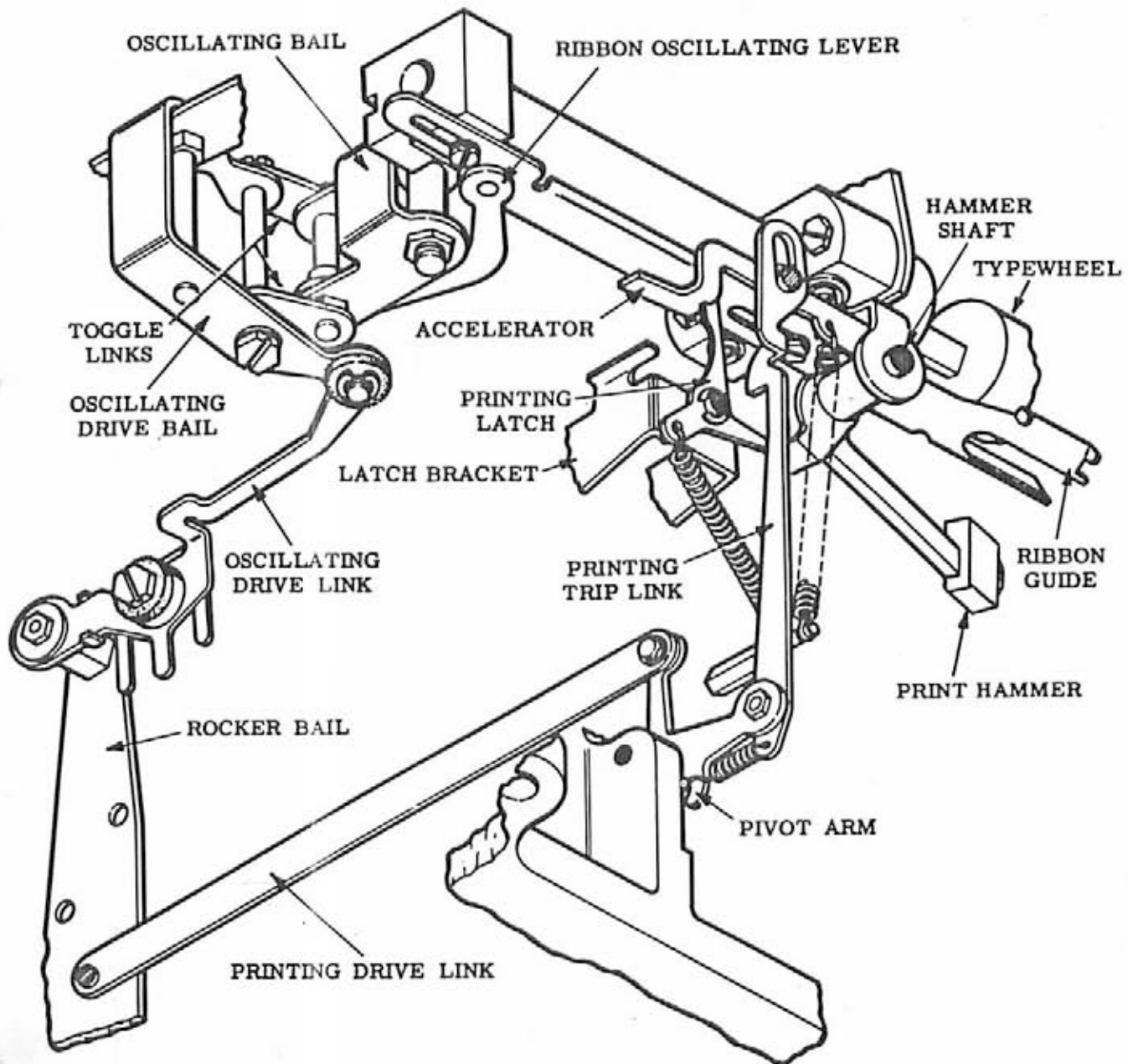

Figure 20 - Printing Mechanism

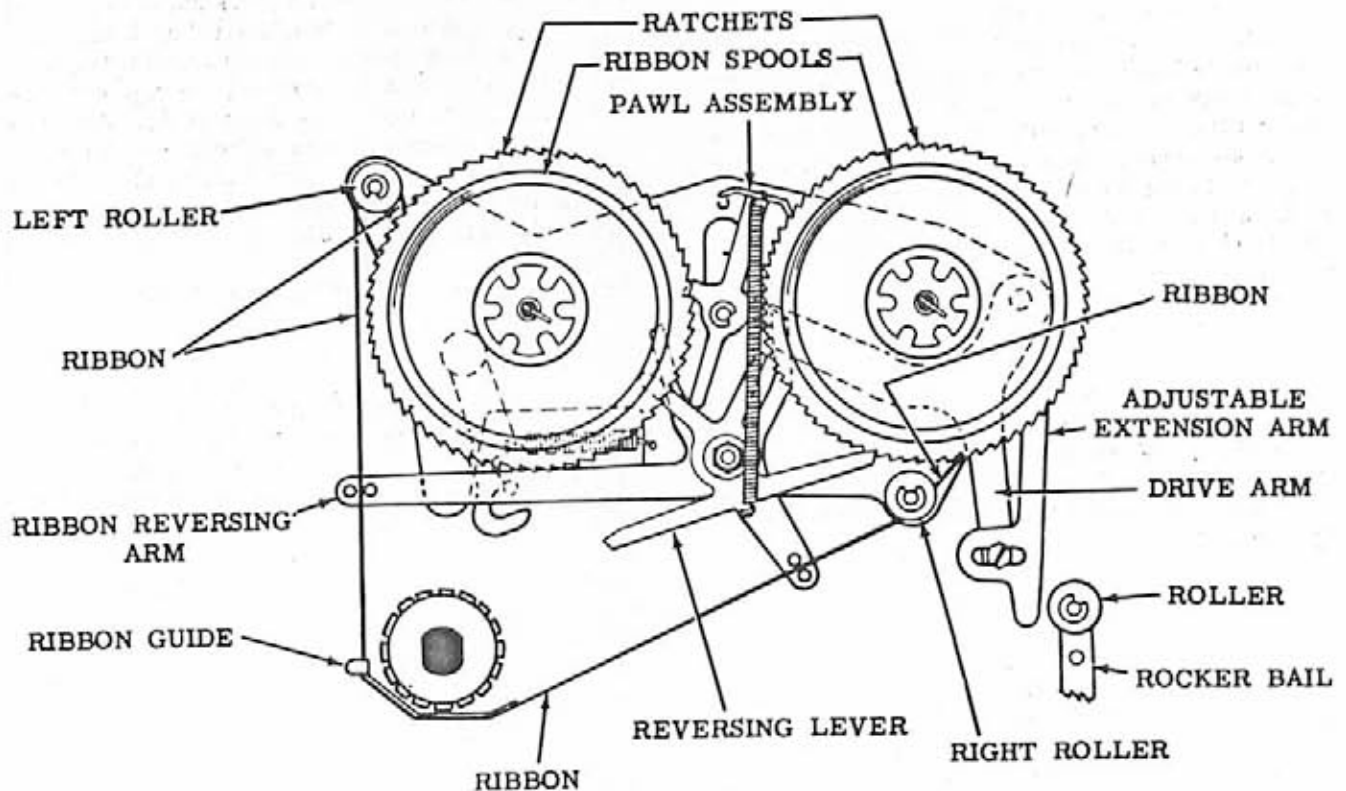

Figure 21 - Ribbon Feed Mechanism

printing, and to retract the typewheel and ribbon guide at the end of the function cycle so that the last typed character is visible. The mechanism mounts on an axial bracket supported by the frame and the front plate and includes an eccentric assembly similar to those of the rotary positioning mechanism (Figures 17 and 18). Two eccentrics, a lower whose pinion is driven by the no. 1 pushbar, and upper whose pinion is driven by the no. 2 pushbar, rotate in a horizontal plane in bearing housings attached to the bracket. The eccentric assembly is linked to the typewheel shaft by an axial output rack and sector as shown in Figure 18.

4.28 The selection of either the no. 1 or no. 2 pushbar results in the maximum displacement toward the rear of the associated eccentric, and the eccentrics are so designed that, if the displacement of the lower is taken to be one unit, that of the upper is two units. Again four permutations are available at the crank pin: zero (neither eccentric displaced), one unit (lower eccentric displaced), two units (upper eccentric displaced), and three units (both eccentrics displaced).

4.29 If during a function cycle neither pushbar is selected, no motion occurs in the axial positioning mechanism with the exception of that resulting from the oscillating assembly (4.30), and the no. 0 character of the selected row is aligned with the hammer at the time of printing (Figure 15). On the other hand, if the no. 1 pushbar is selected, it causes the lower eccentric to revolve and one unit of displacement to be transferred by the crank pin to the axial output rack. The rack moves to the rear and passes the motion to the axial sector which pivots counterclockwise (as viewed from above). The right end of the sector, by means of a cylindrical rack in the typewheel shaft, moves the typewheel one character forward from its home position. The no. 1 character is printed, and when the pushbar reverts to its unselected position it returns the axial linkage and typewheel to their home positions. If the no. 2 pushbar is selected, the no. 2 character is printed, and if both pushbars are selected, the no. 3 character is printed. The cylindrical rack has no lead, and the shaft can thus be rotated while being moved axially.

4.30 With each cycle of the function clutch, an oscillating drive link transfers from the rocker bail an unselected motion to an oscillating drive bail (Figures 18 and 20). This movement is passed by toggle links to an oscillating bail and the sector pivot. The effect of this action is to introduce a separate motion to the sector tending to cause it to pivot about the teeth on the output rack. During the fore part of the function cycle, if no axial pushbar is selected, the right end of the sector is moved forward slightly and positions the no. 0 character for printing. At the end of any cycle the sector retracts the typewheel slightly so that the last printed character is visible. Concurrent with the above operation, a ribbon oscillating lever is made to pivot about its left end and with each cycle projects and retracts the ribbon guide which would obstruct the view of the character (Figure 20).

#### Correction (Figures 16 and 18)

4.31 After the typewheel has been positioned by the axial and rotary positioning mechanisms, the selected character is more accurately aligned for printing by the correcting mechanism which compensates for any play and backlash in the positioning linkages. Each function cycle the rocker bail transfers motion through a correcting drive link to a correcting clamp and shaft (Figure 18). The shaft pivots a rotary correcting lever (Figure 16) which is equipped with an indentation that engages a tooth in a typewheel rack. There is a tooth in the rack for each row of characters (16 in all), and they are so correlated with the typewheel that when a tooth is engaged by the corrector, its row is accurately aligned with the print hammer. Axial correction, which is accomplished simultaneously, is similar to rotary correction: the drive link rotates an axial correcting plate counterclockwise (as viewed from the above), and a roller mounted on the plate engages a notch in the axial sector (Figure 18). Thus the typewheel is accurately aligned in both fields of motion just before printing takes place. During the latter part of the function cycle, a correcting drive link spring returns the correcting mechanism to its home position.

4.32 Since the rocker bail is the source of motion for both the pushbars and the positioning mechanisms, correction must take place at a point near enough to the extreme travel of the bail that it does not interfere with the movement of the typewheel rack or axial sector. In addition, because the rocker bail

controls the tripping of the print hammer, which occurs very late in the bail's stroke, it becomes necessary to utilize the time between the tripping of the hammer and its striking the paper to accomplish correction. The delay in actuating the correcting mechanism is effected by allowing a drive stud on the rocker bail to slide in an elongated slot in the correcting drive link during the early part of the cycle.

#### Letters-Figures Shift (Figures 16 and 19)

4.33 The purpose of the letters-figures shift is to rotate the typewheel from the home position of one section to that of the other (Figure 15). It is effected by means of the function box mechanism which is made up of a number of assemblies mounted on two plates located at the upper rear of the typing reperforator (Figure 19). When the unit is in the letters condition, as shown in Figures 16 and 19, and the figures code combination (12-45) is received, the transfer mechanism sets up the figures arrangement in the bell cranks during the selecting cycle (4.08). Then, as the rocker bail moves from its home position during the first part of the function cycle, a lifter roller, under spring pressure, follows a camming surface on the rear arm of the bail (Figure 19). The lifter allows letters and figures function blades to move down and, by means of tines on their lower surface, feel for an opening in the slotted upper arms of the bell cranks.

4.34 The slot arrangement of the no. 1, 2, 4 and 5 bell cranks is identical and permits the entry of both function blades when all are selected. However, on receipt of the figures code combination, the no. 3 bell crank permits entry of the figures blade while blocking the letters blade. In moving all the way down, the figures blade encounters a projection of a figures arm assembly and causes the arm assemblies to shift from their letters to figures position. A yield arm extension attached to the figures arm assembly pivots a figures extension arm away from the letters-figures bell crank. A letters extension arm, under spring tension, rotates the bell crank clockwise (Figure 19) and the bell crank lifts the letters and figures pushbars. As the bail reaches its extreme position, the lifter is cammed up and raises the function blades.

4.35 While the letters-figures bell crank is being positioned by the function box, the no. 1, 2 and 4 pushbars are selected, the typewheel is moved two rows clockwise and three



characters forward, and the figures symbol is printed (4.21 - 4.27). On its return stroke, the rocker bail operating blade encounters a shoulder on the figures pushbar (which was lifted as described above) and moves the bar to the right as viewed from the front in Figures 16 and 17. The common pinion moves the letters pushbar to the left, and the left front eccentric shifts from its up to down position. Since the typewheel has been displaced two rows clockwise during the first part of the cycle, it is rotated six more rows to the figures home position. As the bail returns to its home position during the last half of the cycle, a lock lever toggle linkage (Figure 19) prevents the lifter roller from following its camming surface, and the lifter holds the function blades up so they do not drop onto the bell cranks. As the bail nears its home position, a trip post riding on the oscillating drive link strikes a lock release arm, buckling the toggle linkage and permitting the lifter roller to again fall on the bail camming surface.

4.36 In a manner similar to that just described, when the letters code combination (12345) is received, the function box causes the letters-figures bell crank to lower the letters and figures pushbars. The wheel is rotated two rows counterclockwise during the first part of the cycle, and six more rows to the letters home position during the last part of the cycle, and the letters bar is moved to the right. The primary two-row rotation of the typewheel, which is made possible by selecting the no. 5 pushbar on spacing rather than marking, provides less throw and smoother operation than would be possible if the complete eight-row displacement were effected during the latter part of the cycle. In each operation the lifter permits the function blades to move down and feel for an opening, except for the shift operations where they are blocked by slotted arms of the bell cranks.

#### C. Printing (Figure 20)

4.37 After the typewheel has been positioned and corrected, the printing mechanism supplies the impact which drives the paper and ribbon against the selected character. It effects this operation by means of a print hammer which is mounted on a shaft supported by a bracket attached to the typewheel bearing housing. In its unoperated condition, as illustrated in Figure 20, the hammer is held against an accelerator by a relatively weak spring. The accelerator is mounted on the hammer shaft and is retained by a printing latch in its upper position against the tension of a relatively strong spring.

4.38 The rocker bail, during the fore part of the function cycle, moves a printing drive link to the right (as viewed from the rear in Figure 20) and causes a pivot arm to rotate clockwise. The arm lowers a trip link which slides in an elongated slot. Near the end of the rocker bail's travel, the trip link pivots the latch which releases the accelerator. Under the spring tension, the accelerator snaps down and impels the hammer upward. The face of the hammer drives the tape and inked ribbon up against the typewheel and imprints the selected character on the tape. The accelerator does not follow the hammer through the complete printing stroke. Near the end of its travel, the accelerator encounters a projection on a latch bracket, and inertia carries the hammer the rest of the way. As the rocker bail returns to its home position, it causes the trip link to move up, release the latch, and return the accelerator to its latched position.

#### D. Ribbon Feeding (Figure 21)

4.39 The characters are typed in ink supplied by an inked ribbon which is held between the tape and the typewheel by a guide and advanced by the ribbon feed mechanism (Figure 21). The path of the ribbon is down to the right off the top of a right spool, under a right roller, through right pins on the reversing arm, through the guide, up through left pins on the reversing arm, over a left roller, and to the right over the top of a left spool.

4.40 During each function cycle, as the rocker bail nears the end of its left travel, a roller mounted on its forward arm pivots a drive arm clockwise. The drive arm lifts a feed pawl which advances the ribbon by rotating a ratchet on one of the ribbon spools one tooth. A retaining pawl under spring tension detents the ratchet while the feed pawl, during the latter part of the function cycle, is lowered so as to engage the next tooth. Each operation, the ribbon is advanced in this manner until the ribbon feed mechanism is reversed.

4.41 When a spool is almost depleted, a rivet in the ribbon encounters pins on the reversing arm, and the stress applied through the ribbon as it is rolled on the other spool pivots the arm. As the pawl assembly is lowered at the end of the next operation, an extension strikes the reversing arm, and the pawl is shifted against the other ribbon spool ratchet. The pawl's rounded lower extension pivots a reversing lever which shifts the retaining pawl so that it engages

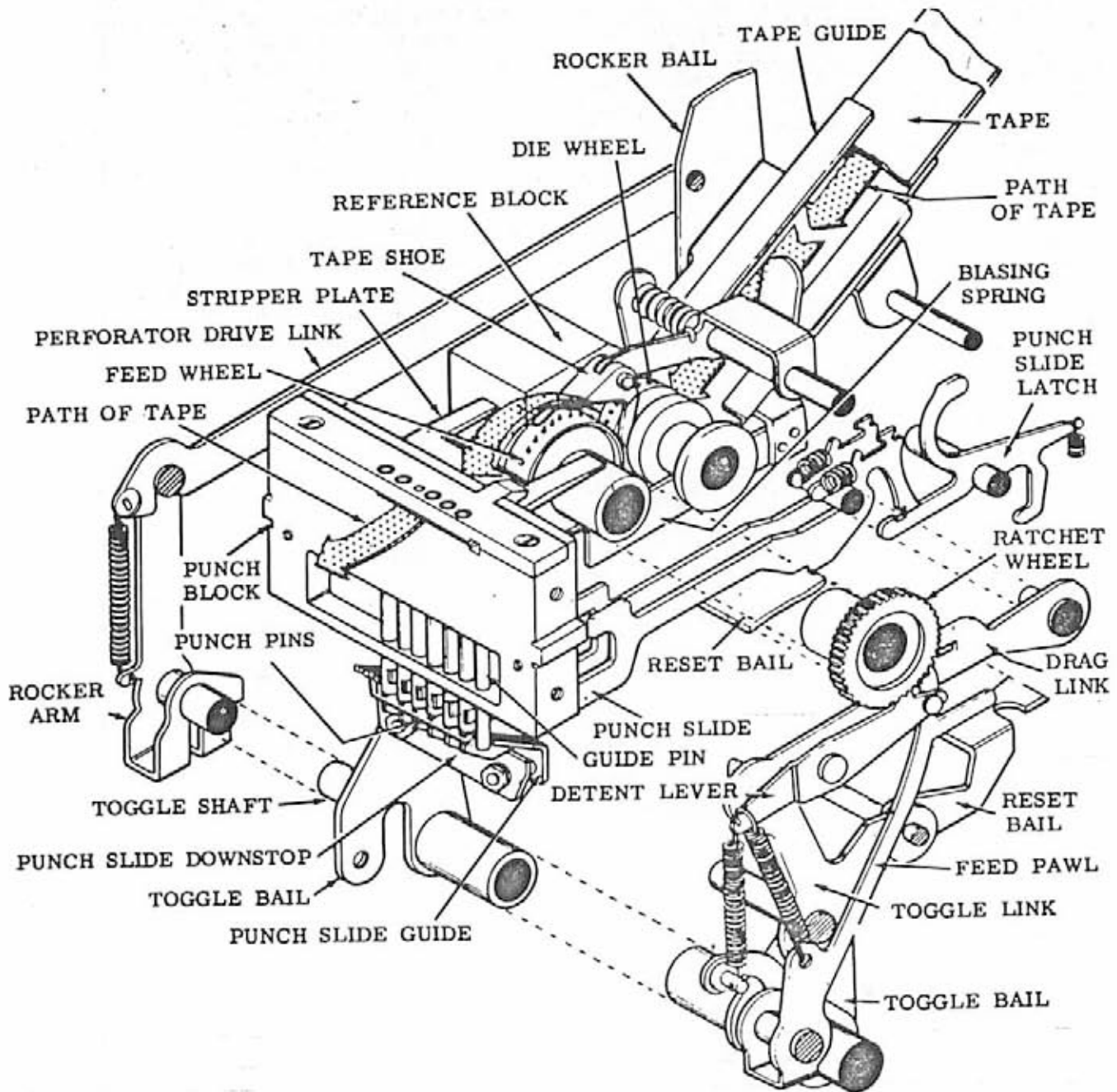

Figure 22 - Perforating Mechanism — Fully-Perforated Unit

the opposite ratchet. The ribbon will then feed in the opposite direction until again reversed. A detent holds the reversing arm in position until its next reversal.

## TAPE PERFORATING AND FEEDING

### A. General

4.42 The perforating mechanism punches feed holes, advances the tape, and perforates combinations of code holes corresponding to the code combinations received from the keyboard. Intelligence is received from the keyboard by the punch slides, which select proper pins in a punch block assembly (Figures 22 and 23). Motion from the rocker bail is distributed to the pins and the tape feeding parts by a main bail assembly which includes a toggle bail, toggle shaft, slide post, toggle links, drag links, and the punch slide reset bail.

### B. Perforating — Fully-Perforated Units (Figure 22)

4.43 After selection, the reset bail is lowered and releases the five punch slides (Figure 22). The selected slides move to the left, and the unselected slides are retained to the right by their latches. In the selected position, a projection of each slide extends over the slide post. Since a feed hole is perforated every operation, the punch slide associated with the feed-hole punch pin is designed so that it is always in a selected position. During the first part of the function cycle, the rocker bail moves to the left and, by means of a drive link and rocker arm, rotates the toggle shaft and bail counter-clockwise. Toggle links attached to the front and rear of the bail lift the slide post and move the reset bail to the left. The selected slides are carried upward by the post and force the associated pins through the tape. The slides pivot about the same point as the drag links, and thus become an integral part of the main bail assembly during the perforating stroke. Approximately midway through the function cycle, the function trip assembly lifts the reset bail.

4.44 During the last half of the cycle, the toggle bail is rotated clockwise pulling the slide post down and lowering the selected punch slides. The punch slides, which engage notches in their respective punch pins, pull the punch pins down below the tape. The main bail assembly and the selected punch slides and their associated punch pins move as a unit during the perforating stroke. The openings in the die block

above the tape, through which the pins protrude, are circular so that the entire hole is punched.

4.45 A chad chute, mounted on the retractor punch block, mates with a chute on the base, and carries the chad punched from the tape into a chad container.

### C. Perforating — Chadless Units (Figure 23)

4.46 Up to a certain point, the principle of operation of the chadless punch is the same as that for the fully perforated unit. After selection, the reset bail is lowered and releases the five punch slides (Figure 23). The selected slides move to the left, and the unselected slides are retained to the right by their latches. In the selected position, a projection of each slide extends over the slide post. During the first part of the function cycle, the rocker bail moves to the left and, by means of a drive link and rocker arm, rotates the toggle shaft and bail counter-clockwise. Toggle links, attached to the front and rear of the bail, lift the slide post and move the reset bail to the left. The selected slides are carried upward by the post and force the associated pins through the tape. The slides pivot about the same point as the drag links, and thus become an integral part of the main bail assembly during the perforating stroke. A retractor bail, which engages notches in the punch pins, is pivoted clockwise as the pins move up through the tape. Approximately midway through the function cycle, the function trip assembly lifts the reset bail.

4.47 During the last half of the cycle, the toggle bail is rotated clockwise and lowers the punch slides. The reset bail, moved to the right by the toggle links, drives the slides back to their unselected positions where it holds them until the next operation. The retractor bail, under spring pressure, holds the punch pins down against the slides until the pins are retracted below the tape. The notches in the pins are long enough to allow the retractor bail to pivot its full amount without lifting the unselected pins against the tape, but are short enough to permit the bail to serve as a downstop for the pins, and thus hold them in the block. A compression spring is mounted on the no. 3 punch pin, and four tension springs are hooked to the slide post and the retractor bail. The main bail assembly, retractor bail, and selected slides and punch pins move as a unit during the perforating stroke, and the retractor bail tension springs are not part of the load on the toggle shaft. The openings in the block above the tape,

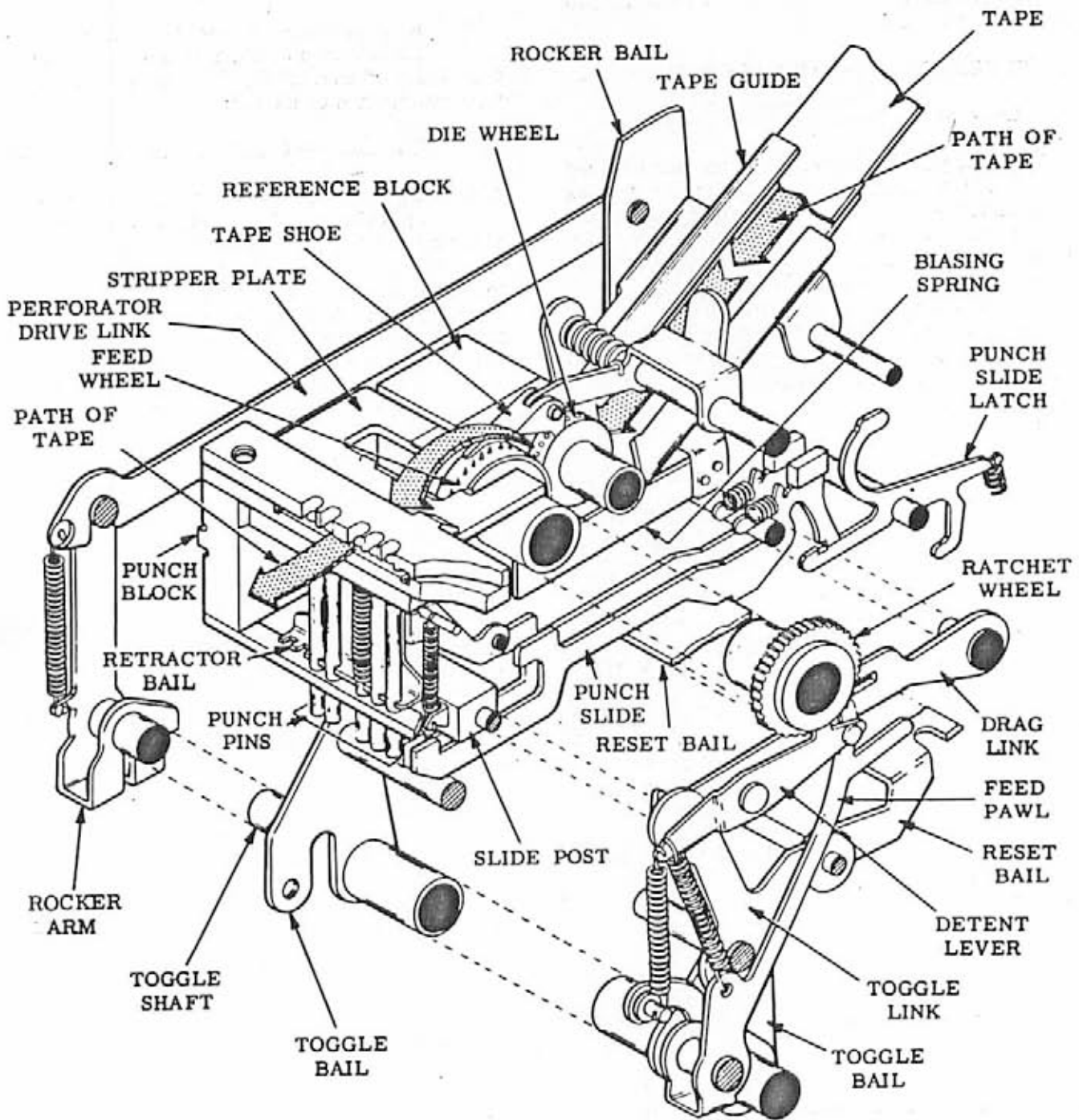

Figure 23 - Perforating Mechanism — Chadless Tape Unit

through which the selected pins protrude, are semicircular, so that only the rear portion of the hole is severed.

#### D. Feeding — Fully-Perforated and Chadless Units

4.48 Tape feeding is accomplished after perforation during the last half of each function cycle. The tape is threaded down through a tape guide and then up between a feed wheel and die wheel (Figures 22 and 23). A feed pawl driven by the toggle bail acts upon a ratchet and rotates the feed wheel which, by means of pins and a slot in the die wheel, advances the tape one character at a time. A detent, with a roller that rides on the ratchet, holds the feed wheel and tape in position during perforation. The detent and feed pawl springs are so positioned that the pressure of the detent on the ratchet is high during the first half of the cycle (to hold the tape in position during perforation), but is low during idling and the last half of the cycle, to facilitate tape threading and feeding. A tape shoe retains the tape on the feed wheel and a guide spring holds it back against a reference block so that the feed holes are punched a uniform distance from the edge. The tape is stripped from the feed wheel by a stripper plate, passes into the punch block where it is printed and perforated, and finally emerges at the left. A guide spring, by holding the tape back against a reference surface on the block, maintains a uniform relationship between the code perforations and the edge of the tape.

### 5. VARIABLE FEATURES

#### BACKSPACE MECHANISMS (Figures 4 and 24)

##### A. General

5.01 The backspace mechanism steps the tape back through the punch block in order to delete perforated errors. The erroneously perforated code combination in the retracted tape is then obliterated by perforating the letters code combination in its place. The backspace mechanism may be operated manually or it may include power drive. The mechanism used with chadless tape differs from that used with fully perforated tape in that it contains a tape rake for depressing the chad. The mechanisms are shown in Figure 24.

##### B. Manual Backspace (Fully-Perforated Tape)

5.02 Depressing the handle of the backspacing bell crank disengages the perforator feed pawl from the feed wheel ratchet. The backspacing feed pawl then engages the feed wheel ratchet and rotates the feed wheel clockwise, backspacing the tape to the next row of perforations.

##### C. Manual Backspace (Chadless Tape)

5.03 Depressing the handle of the backspacing bell crank disengages the perforator feed pawl from the feed wheel ratchet and simultaneously rotates the rack to depress the chads. The backspacing feed pawl then engages the feed wheel ratchet and rotates the feed wheel clockwise, backspacing the tape to the next row of perforations.

##### D. Power Drive Backspace

5.04 A start magnet in the power drive mechanism is energized by a remote source. When energized, the armature bail is pulled downward. An extension of the bail disengages the drive link latch, which drops and engages a notch in the eccentric arm. The eccentric arm, driven by the perforator main shaft, moves to the right. This action causes the bell crank handle to be depressed through a system of linkages between the drive link latch and the bell crank. The subsequent operation is as described in Paragraphs 5.02 and 5.03.

#### CODE READING CONTACT MECHANISM (Figure 25)

5.05 These contacts are used to electrically read the code combinations being perforated. The code information is fed to external electrical circuits for end use. The mechanism consists of a bank of five make-type contacts mounted adjacent to the perforator punch slides. Each contact is actuated by its associated punch slide. In the perforator stop position, each code reading contact is held open by engagement with an insulator on its associated punch slide. When the selected punch slides move toward the punch block during the selection cycle, the associated contacts close. The resulting electrical output consists of spacing and marking pulses corresponding to the code combinations being perforated.

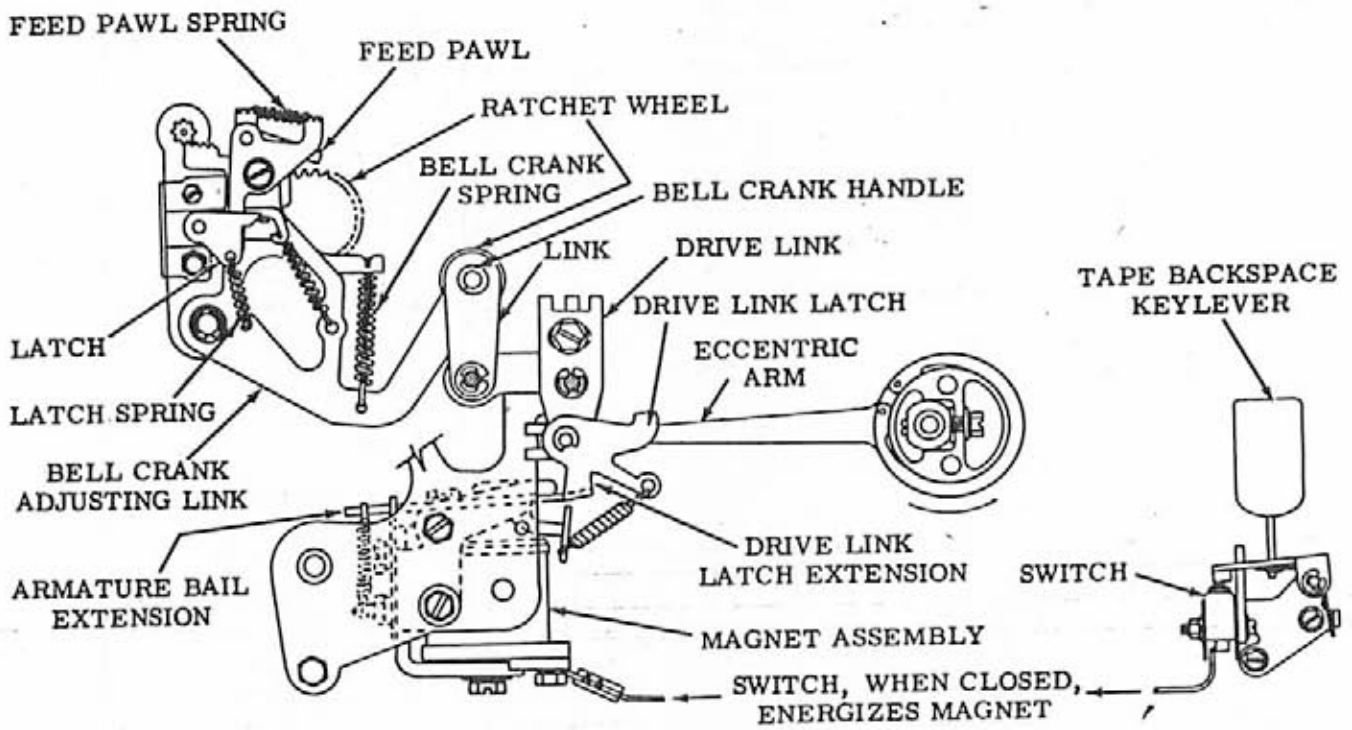
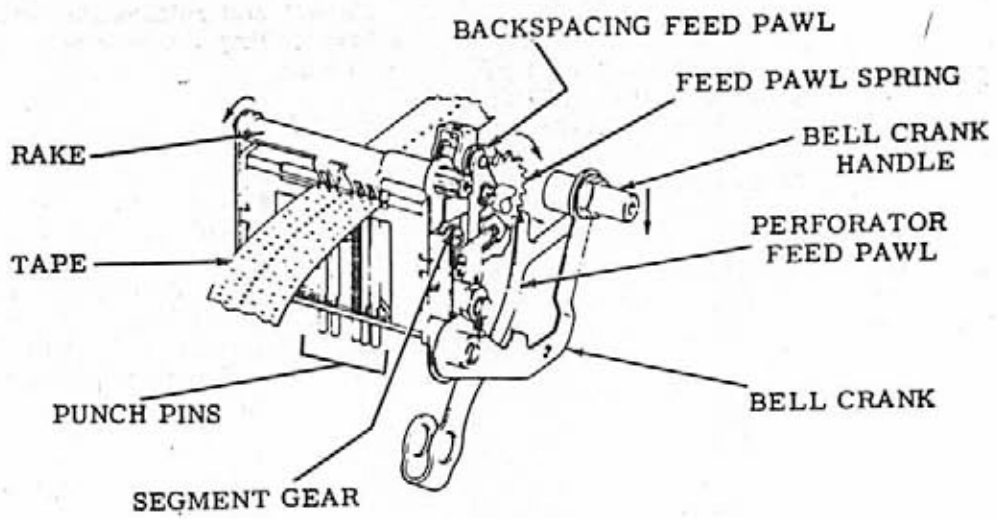

Figure 24 - Backspace Mechanism

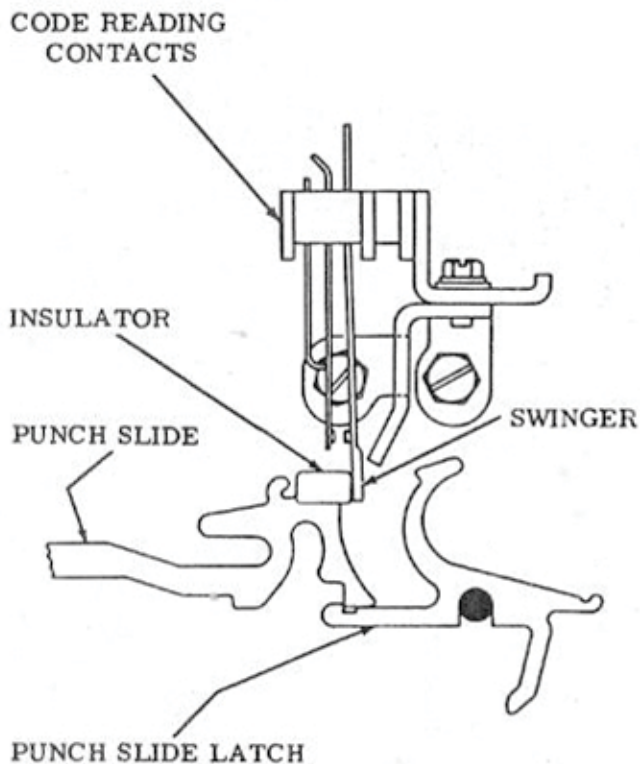

Figure 25 - Code Reading Contact Mechanism

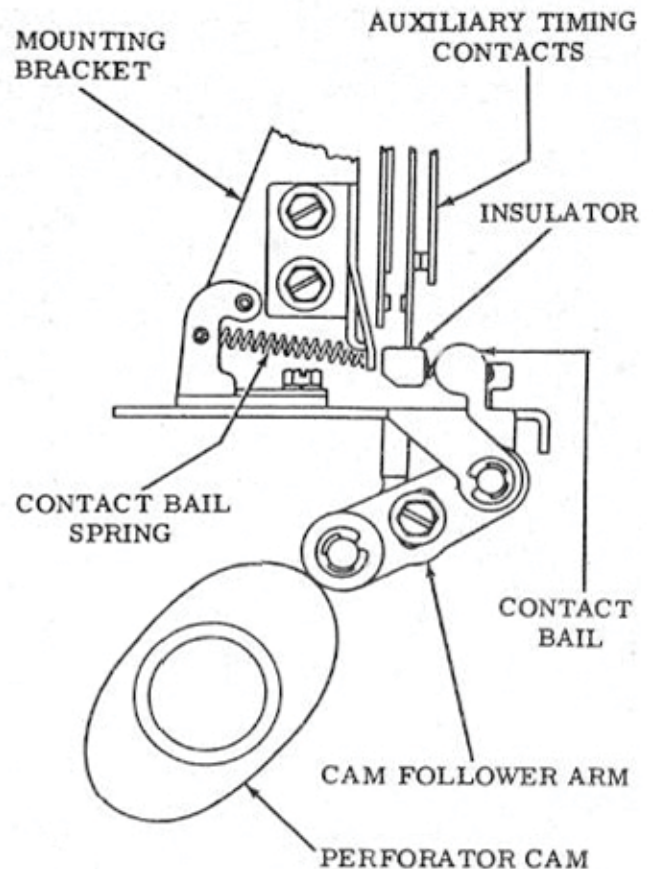

Figure 26 - Auxiliary Timing Contact Mechanism

#### AUXILIARY TIMING CONTACT MECHANISM (Figure 26)

5.06 This contact provides electrical pulses which are synchronized with the code reading contact pulses for circuitry control purposes. The mechanism consists essentially of a signal contact pile-up of the break-before-make type and a contact bail and cam follower arm. The mechanism is mounted to the frame

of the perforator so that the cam follower arm is actuated by the perforator function cam. In the stop position, the contacts, bail, and cam follower arm are positioned as shown in Figure 26. When the cam rotates, the cam follower falls and the contact bail engages the swinger insulator to close the contacts at the left. On the second half of the cam cycle, the cam engages the cam follower roller and restores the contacts to their normal stop positions.