

BULLETIN 234B
TECHNICAL MANUAL
MULTIPLE WIRE DISTRIBUTOR
(LD)

SECTIONS

1. DESCRIPTION
2. PRINCIPLES OF OPERATION
3. ADJUSTMENTS AND SPRING TENSIONS
4. LUBRICATION

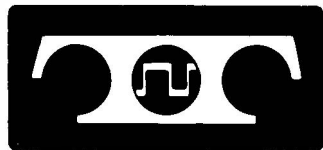

TELETYPE[®]
CORPORATION
5555 TOUHY AVENUE, SKOKIE, ILLINOIS

© 1956 by Teletype Corporation in the United States.
Copyright in all countries participating in International
Convention and Pan American Conventions. All rights
reserved including rights of translations into all
languages.

Portions reproduced from Teletype Bulletin 276B.
© 1962 by Teletype Corporation.
All rights reserved.

Printed in U. S. A.

LIST OF EFFECTIVE PAGES

OCTOBER, 1963

(Supersedes August, 1961, Issue)

Page Number	Change In Effect
A to E	Change 3
1-1 to 1-5	Change 3
2-0 to 2-3	Change 3
3-1 to 3-20	Change 3
4-1 to 4-7	Change 3

The above list indicates the effective pages as of the date of issue. Upon receipt of change pages, insert them numerically and discard any superseded pages.

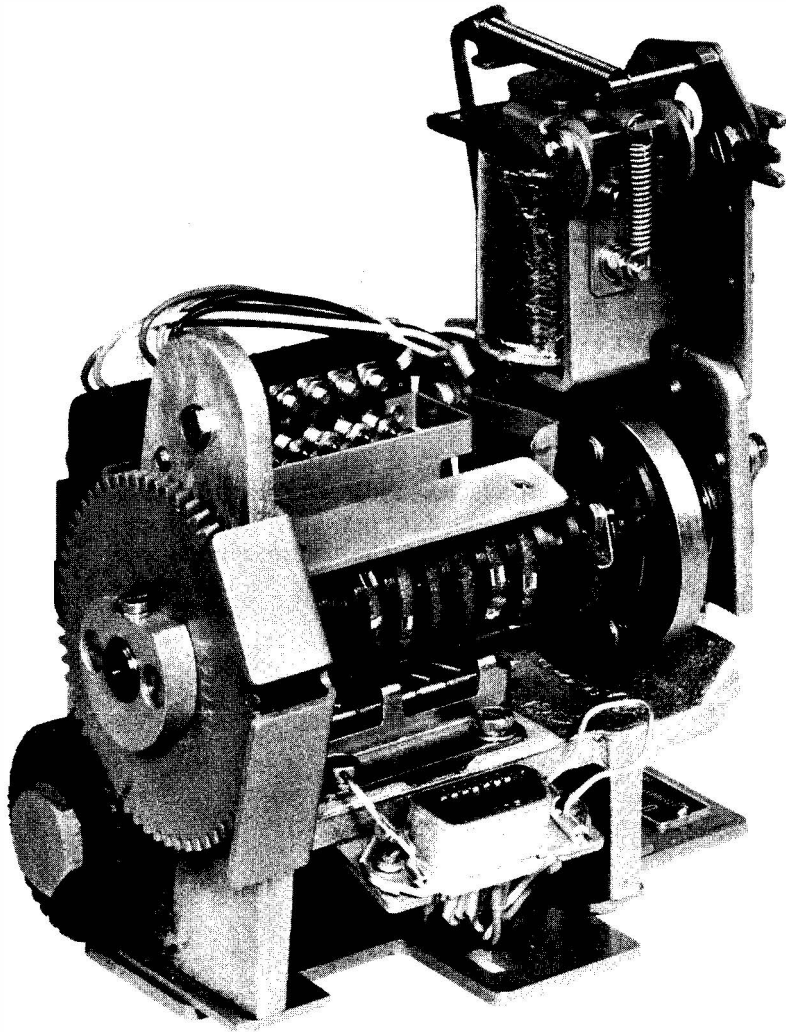

MULTIPLE WIRE DISTRIBUTOR UNIT

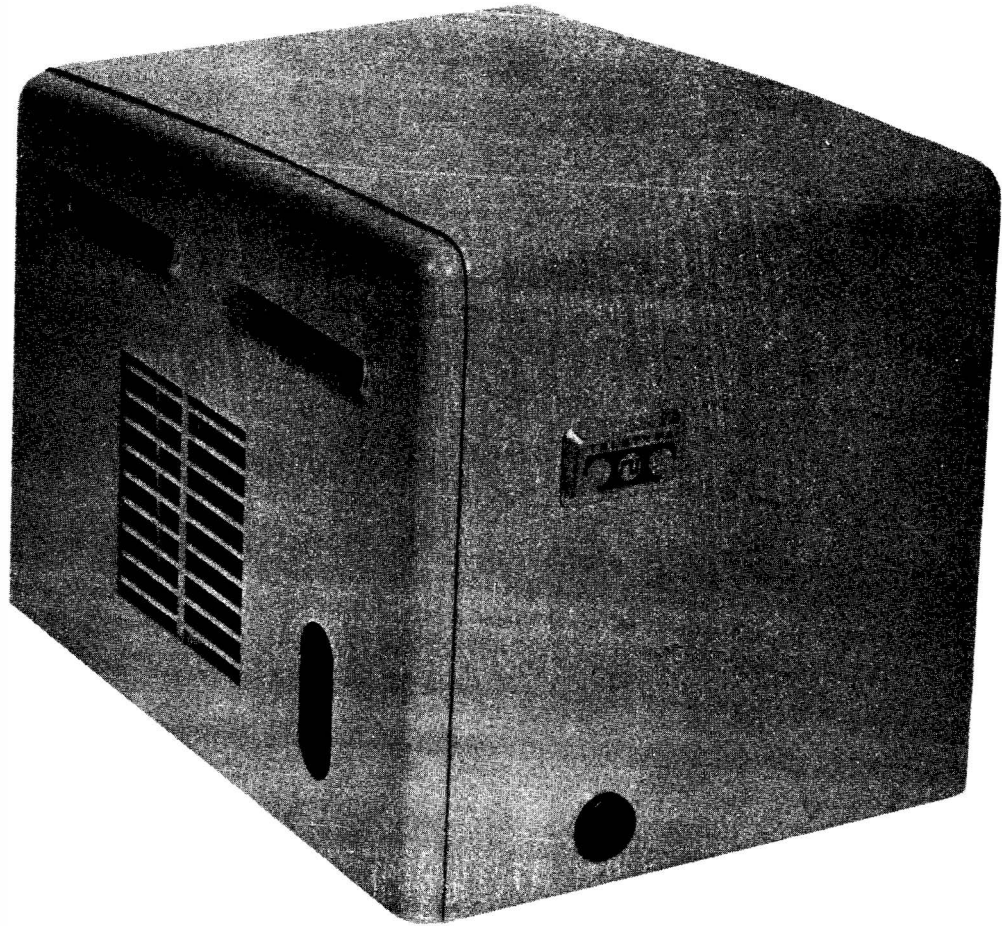

MULTIPLE WIRE DISTRIBUTOR SET
Consists of
Base (LRSB), Distributor Unit (LD),
and Motor Unit (LMU)

CHANGE 3

TABLE OF CONTENTS

<u>Paragraph</u>	<u>Page</u>
List of Effective Pages	A
Multiple Wire Distributor Unit - Photograph	B
Multiple Wire Distributor Set - Photograph	C
Table of Contents	D and E
 SECTION 1 - DESCRIPTION.	 1-1 through 1-5
1-1. Introduction	1-1
1-2. General	1-2
1-3. Multiple Wire Distributor Unit	1-2
1-4. Base and Motor Unit	1-4
 SECTION 2 - PRINCIPLES OF OPERATION	 2-0 through 2-3
2-1. General	2-1
2-2. Code	2-1
2-3. Motor Unit	2-1
2-4. Multiple Wire Distributor Unit	2-2
a. Main Shaft Motion	2-2
b. Contact Mechanism	2-3
 SECTION 3 - ADJUSTMENTS AND SPRING TENSIONS	 3-1 through 3-20
3-1. General	3-1
3-2. Multiple Wire Distributor Unit Adjustments - Late Design	3-2
Armature Extension	3-2
Cam Follower Guide	3-3
Clutch Latch Lever Spring	3-7
Clutch Magnet Armature Bail Spring	3-7
Clutch Shoe Lever	3-3
Clutch Shoe Lever Spring	3-4
Clutch Shoe Spring	3-5
Clutch Stop Arm	3-3
Clutch Trip Armature Air Gap	3-2
Clutch Trip Lever	3-2
Clutch Trip Lever Spring	3-7
Signal Pulse (Final Adjustment with DXD or Strobe)	3-8
Distributor Block Assembly	3-4
Distributor Cam Follower Spring	3-5
Distributor Contact Gap	3-4
Distributor Rocker Compression Spring	3-6
Distributor Rocker Spring	3-6
3-3. Multiple Wire Distributor Unit Adjustments - Early Design	3-10
Armature Spring	3-13
Cam Sleeve End Play	3-10
Clutch Latch Lever Spring	3-11
Clutch Shoe Lever	3-14
Clutch Shoe Lever Spring	3-15
Clutch Shoe Spring	3-15
Clutch Trip Lever and Latch Lever	3-12
Clutch Trip Lever Spring	3-11
Contact Bracket	3-16
Contact Gap and Short Contact Spring	3-17
Contact Lever Shaft Spring	3-16
Long Contact Spring (Final)	3-18

<u>Paragraph</u>	<u>Page</u>
Long Contact Spring (Preliminary)	3-17
Magnet Bracket	3-11
Reset Lever	3-13
Trip Lever Shaft Spring	3-14
3-4. Base and Motor Unit Adjustments	3-19
Intermediate Driving and Unit Driven Gear Mesh	3-19
Motor Pinion and Intermediate Driven Gear Mesh	3-19
Motor Shield	3-20
 SECTION 4 - LUBRICATION	 4-1 through 4-7
4-1. General	4-1
4-2. Multiple Wire Distributor Unit Lubrication - Late Design	4-2
Clutch Trip Magnet Mechanism	4-2
Contact Lever and Cam Sleeve Assemblies	4-3
4-3. Multiple Wire Distributor Unit Lubrication - Early Design	4-4
Clutch and Gear Assemblies	4-5
Clutch Trip Mechanism	4-6
Contact Lever and Cam Sleeve Assembly	4-4
Multiple Wire Distributor (Front View) - Photograph	4-4
Multiple Wire Distributor (Rear View) - Photograph	4-5
4-4. Base and Motor Unit Lubrication	4-7
Motor and Gear - Photograph	4-7

SECTION 1
DESCRIPTION

1-1. INTRODUCTION

a. This manual presents technical information for the Multiple Wire Distributor Unit. The Sending Distributor Base and Motor Unit used to provide a Multiple Wire Distributor Set are also covered in this manual.

b. The manual is divided into four sections. Section 1, Description, contains a brief physical and functional description of the equipment. Section 2, Principles of Operation, explains how the equipment operates, with pertinent figures. Section 3, Adjustments and Spring Tensions, includes all adjustment and spring tension requirements. Section 4, Lubrication, gives the proper lubrication instructions for the equipment.

c. Refer to the Multiple Wire Distributor Parts Bulletin for disassembly and detailed arrangement of associated parts. For installation of the Multiple Wire Distributor Units refer to the appropriate installation specification shipped with the unit.

d. Reference in the text to "left" or "right" refers to the unit in its normal operating condition as viewed from the front unless otherwise noted. Pivot points are shown in the drawings by circles or ellipses which are solid black to indicate fixed points or cross-hatched to indicate floating points.

e. Reference in the text to "early design" and "late design" refer to the Mark I and Mark II Multiple Wire Distributor Units. The Mark I

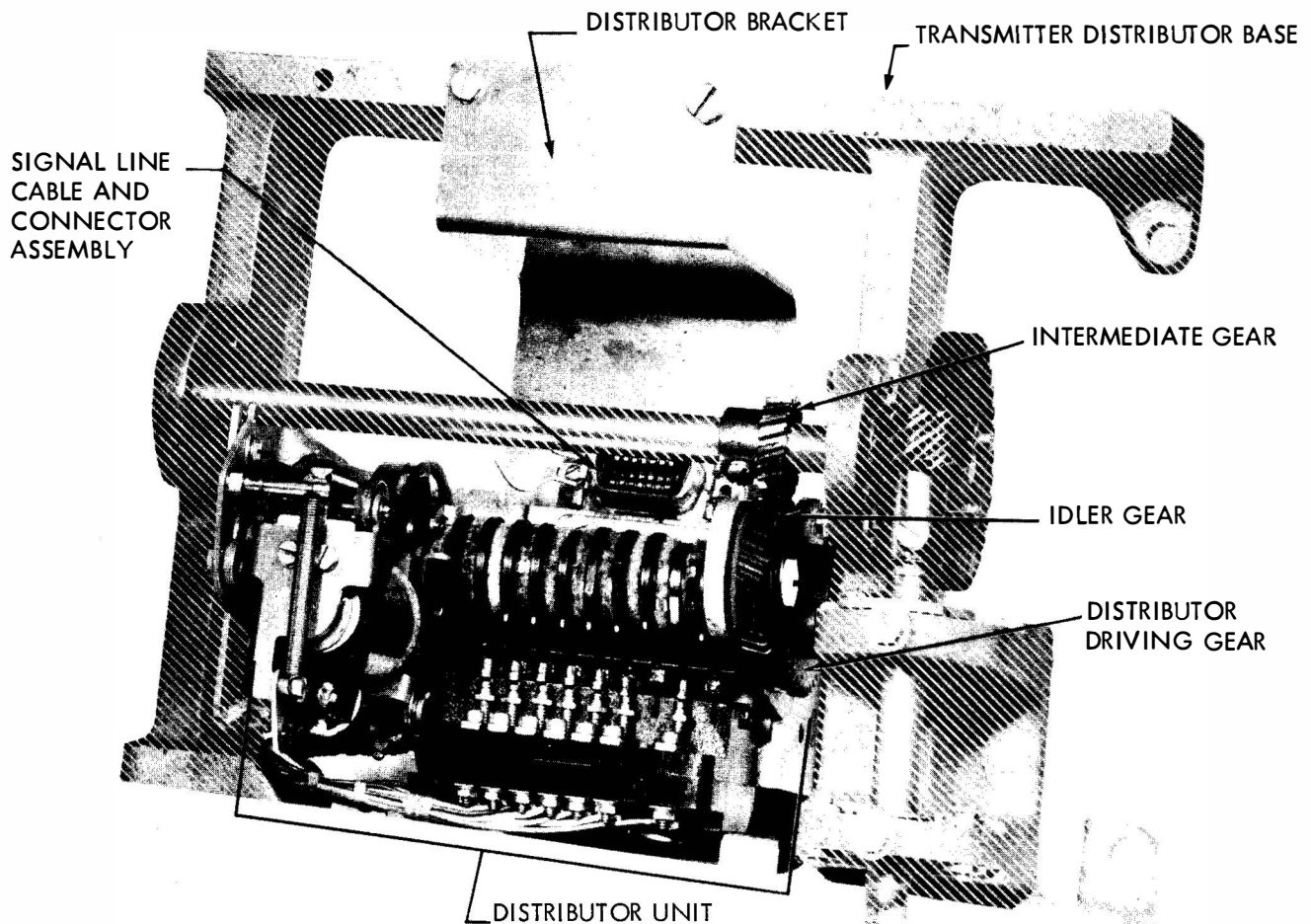

FIGURE 1-1. MULTIPLE WIRE DISTRIBUTOR UNIT MOUNTED ON
ASR SET WITH TRANSMITTER DISTRIBUTOR BASE

five-level unit has a double coil clutch trip magnet and one auxiliary contact. The Mark II five-level unit has a single coil clutch trip magnet and two auxiliary contacts.

1-2. GENERAL

a. The Multiple Wire Distributor Unit is an electromechanical unit which transmits sequential, start-stop telegraphic signals from a parallel (multi-wire) input. Under an external control, such as a push button or stunt box, it will transmit control characters when these are set up externally by coding the Distributor contacts. It may also be used to translate continuous parallel (multi-wire) intelligence into sequential, start-stop signals for transmission or use with Teletype receiving equipment, such as a page printer. Provision is made for mounting the unit on the Model 28 Sequence Selector Base, the Model 28 Send-Receive or Receive-Only Base, the Model 28 Automatic Send-Receive Set (Figure 1), the Model 35 Transmitter Dis-

tributor Base, and the Model 28 Sending Distributor Base.

b. The basic components of the Multiple Wire Distributor Set are a: Multiple Wire Distributor Unit, Sending Distributor Base Unit, and Motor Unit (Figure 2).

c. Multiple Wire Distributor Units are available that will operate in either a five-level, 7.42 unit code transmission or eight-level, 11.00 unit code transmission.

1-3. MULTIPLE WIRE DISTRIBUTOR UNIT (Figure 3)

a. The Multiple Wire Distributor Unit consists of a common distributor assembly, and appropriate mounting bracket and cable assembly for each different installation. The common distributor assembly contains an inverted Model 28 clutch assembly with a cam sleeve. The cam sleeve actuates the contact levers which control

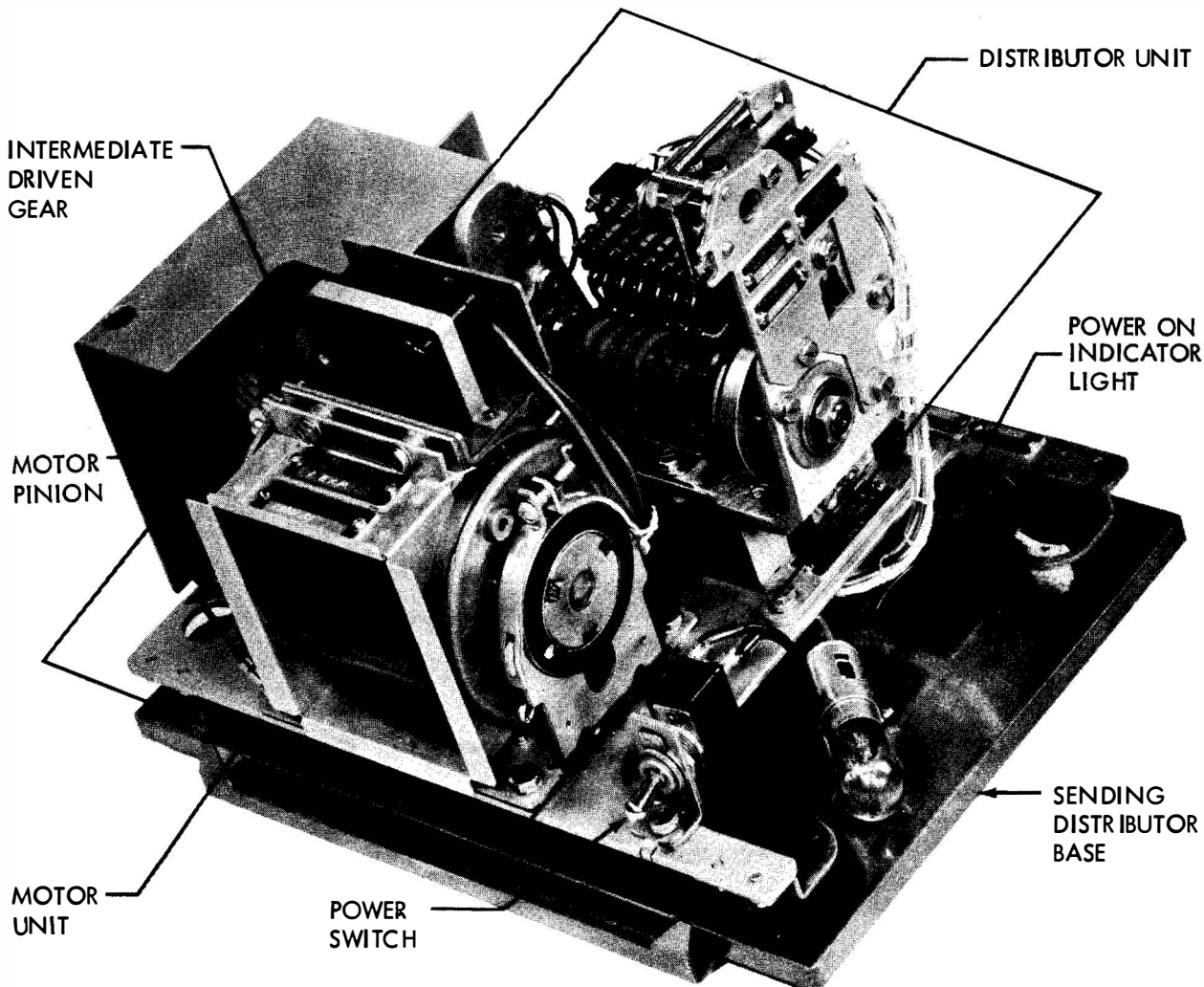

FIGURE 1-2. MULTIPLE WIRE DISTRIBUTOR SET (COVER REMOVED)

the opening and closing of the contacts which generate the sequential, start-stop telegraphic signal. The common distributor assembly also contains a clutch trip magnet assembly. The magnet assembly consists of a magnet coil assembly mounted on an angle bracket which is mounted on a larger bracket. An armature bail and shaft mechanism are mounted on the angle bracket. The clutch trip and reset mechanism are mounted on the larger bracket. Eight cam (ten on eight-level units and seven on early design units) operated contact levers and contacts transmit one or more control characters, such as the letter "V", in Answer Back and Push Button Calling. The cams for five-level late design units are from left to right (clutch on left): 1, 2, 3, 4, 5, Stop, Auxiliary A, Auxiliary B. Early design units have only one auxiliary contact and eight-level units have eight intelligence contacts with one auxiliary contact. A cable connector assembly furnishes the electrical connections from external sources to the contacts and clutch trip magnets.

b. The applicable modification kit consists of a gear train which transmits the required torque to rotate the cam sleeve and clutch assembly. This gear train also makes the necessary connection with the drive gear of the associated unit. Mounting brackets provide for the proper mounting of the distributor assembly. Cables, terminals and terminal mounting hardware are included when applicable.

c. Technical Data

(1) Dimensions

Width	5 inches
Depth	4 inches
Height	6 inches (4 inches in early design units)
Weight	3-1/2 pounds

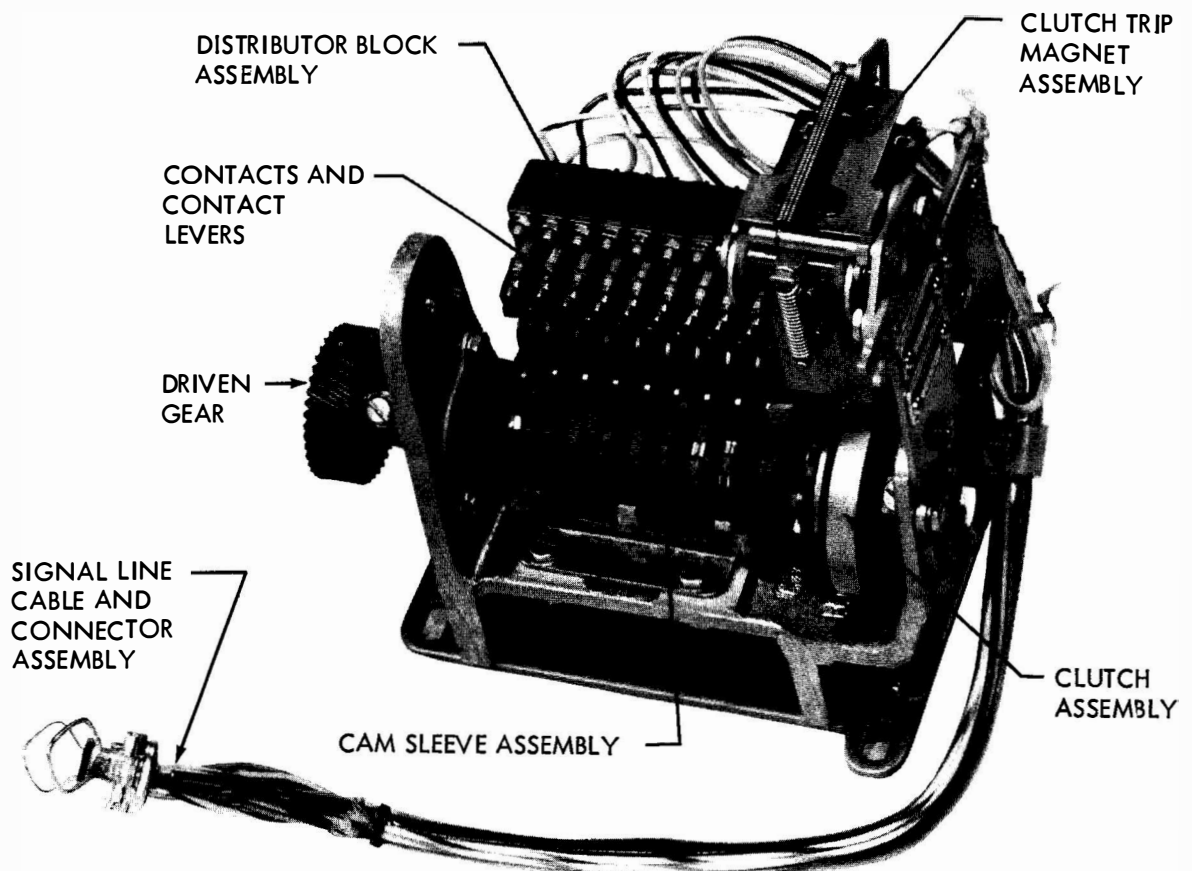

FIGURE 1-3. EIGHT LEVEL MULTIPLE WIRE DISTRIBUTOR UNIT

(2) Rating of Clutch Trip Magnet

DC	0.100 ampere at 48 volts (100 ohm dropping resistor required)
	0.165 ampere at 120 volts (1000 ohm dropping resistor required)

AC 120 volts

(3) Signalling

Input	Parallel (multi-wire)
Output	Start-stop, sequential
Current	0.020 or 0.060 ampere

(4) Speed (operations per minute - o.p.m. and words per minute - w.p.m.)

<u>o.p.m.</u>	<u>w.p.m.</u>
368	60
460	75
600	100

1-4. BASE AND MOTOR UNIT (Figure 4)

a. The Sending Distributor Base and Motor Unit provide mounting, cover and power facilities for a Multiple Wire Distributor Unit to make a Multiple Wire Distributor Set.

b. The Base (LRSB) provides mounting, electrical and cover facilities for the Multiple Wire Distributor (LD) and Motor Unit (LMU). It includes the following features:

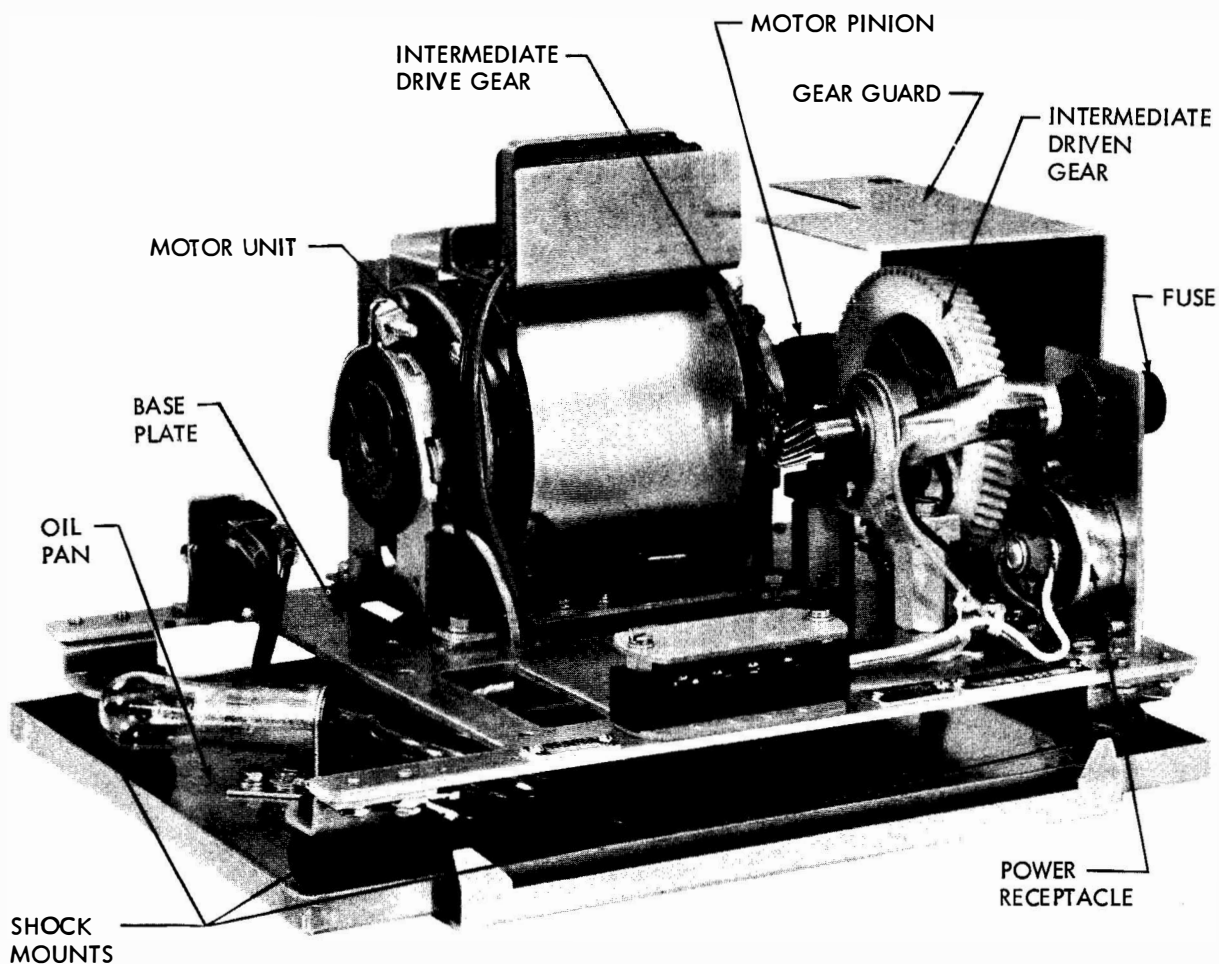

FIGURE 1-4. BASE AND MOTOR UNIT

(1) An oil pan, or sub-base, to catch any oil or grease which may be thrown off or drop from the mounted units.

(2) A base plate to provide mounting facilities.

(3) Vibration dampers and rubber feet to minimize mechanical transmission of noise, and to prevent scratching of the mounting surface.

(4) A gear guard for protection of maintenance personnel.

(5) A dust cover.

(6) An on-off motor control switch, and a fuse for protection of the power circuit.

(7) Terminal block and plug-in facilities for electrical connection of power line and ground.

(8) A power-on indicator lamp.

c. The Motor Unit (LMU) provides the motive power necessary to operate the Multiple Wire Distributor (LD). The Motor Unit mounts on the Base, and is mechanically coupled to the distributor through an intermediate gear assembly. The Motor Unit is a complete assembly, and includes a thermal cutout switch and starting capacitor mounted on a motor bracket.

d. Technical Data

(1) Base

Fuse Rating 2.0 ampere at 125 volts
Lamp Rating 6 watts at 125 volts, Bayonet type

Switch Rating 6.0 ampere at 125 volts, Toggle type
3.0 ampere at 250 volts

Height 8-1/16 inches

Depth 9-3/4 inches

Width 7-13/16 inches

Weight 16-1/2 pounds

(2) Motor Unit

Type Synchronous

Speed 3600 RPM

Input Voltage Single Phase, 115 volts $\pm 10\%$ AC

Frequency 60 cycles (only) $\pm 0.75\%$

Input Current

Starting 5.0 amperes

Running (no load) 1.06 amperes

Running (full load) 1.25 amperes

Power Output 25 milli-horsepower

Protection Thermal cutout

Power Consumption 75 watts

Heat Dissipation 53 watts

Start Capacitor 88-108 MFD

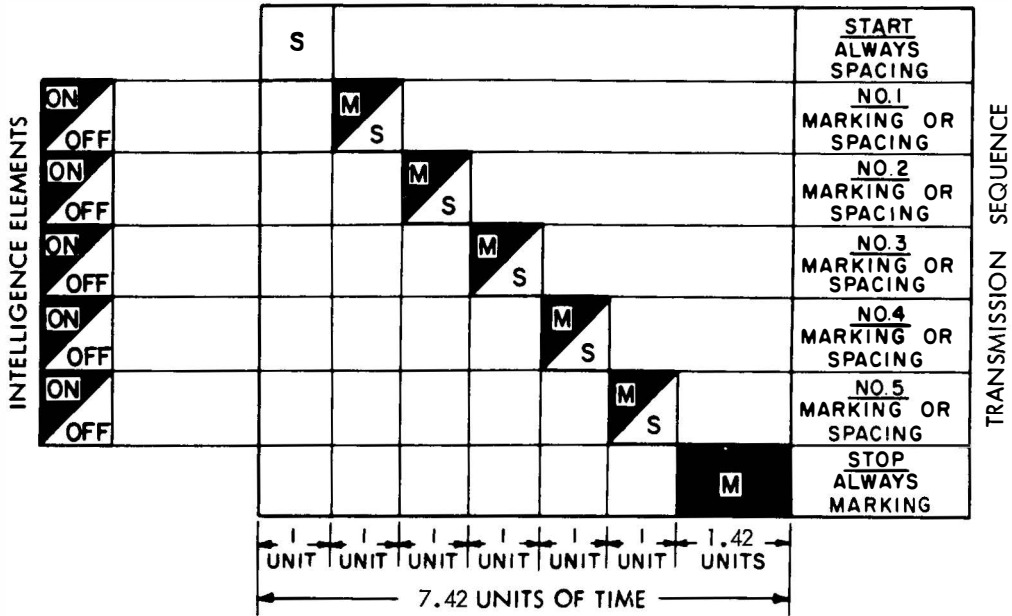

a. FIVE LEVEL PERMUTATION CODE

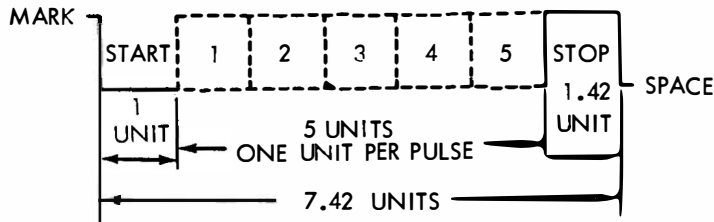

b. FIVE LEVEL START-STOP SIGNALING CODE

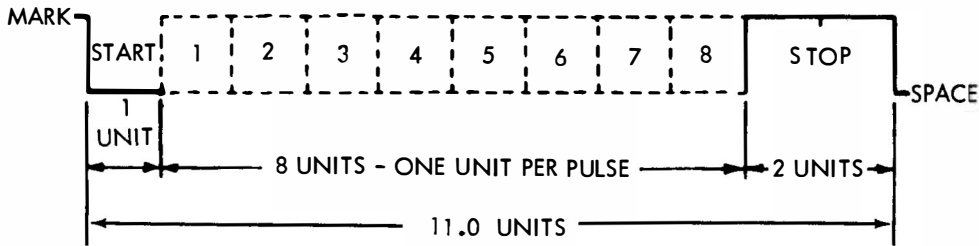

c. EIGHT LEVEL START-STOP SIGNALING CODE

FIGURES	-	5/8	1/8	3/4	8	8	1/2	3/4	7/8	9	0	1	4	5	7	3/8	2	/	6	"	BLANK	LETTERS	FIGURES	SPACE	CARRIAGE RETURN	LINE FEED													
LETTERS	A	B	C	D	E	F	G	H	I	J	K	L	M	N	O	P	Q	R	S	T	U	V	W	X	Y	Z	BLANK	LETTERS	FIGURES	SPACE	CARRIAGE RETURN	LINE FEED							
1	●	●	●	●	●					●					●					●	●	●	●	●	●	●	●	●	●	●	●								
2	●		●				●		●	●	●				●	●	●				●	●	●				●	●	●	●	●	●	●					●	
3			●				●		●	●					●	●	●				●	●	●				●	●	●	●	●	●	●						
4		●	●	●	●					●	●	●	●			●						●	●	●				●	●	●	●	●	●	●					●
5		●					●	●					●	●	●	●					●	●	●	●	●	●	●	●	●	●	●	●	●	●					

d. TYPICAL FIVE LEVEL CHARACTER ARRANGEMENTS

FIGURE 2-1. CODE

SECTION 2

PRINCIPLES OF OPERATION

2-1. GENERAL

This section explains the operation of the Multiple Wire Distributor. In the text that follows, it is assumed that the unit is mounted on a base and that it is receiving motion from a motor unit through the intermediate drive mechanism. It is also assumed that some type of parallel input is applied to the unit and that a means, such as a push button, is available for tripping the cam-clutch assembly. The unit is in its idling condition, and is under power with the cam-clutch disengaged.

2-2. CODE

a. The information handled by the Multiple Wire Distributor is in the form of a binary permutation code. The information, i. e., characters, numerals, etc., are represented by combinations of binary intelligence levels, each of which may be in one of two states, i. e., on-off, mark-space, etc. Different versions of the equipment will accommodate codes whose combinations consist of either five or eight levels. The total number of permutations available in a given code is equal to two to the n power (2^n) where n is the number of levels. In a five level code the number of permutations is two raised to the fifth power or 32.

b. The code (as used by this equipment) is expressed in electrical form only. Each level of the code combinations consists of either a current condition (referred to as a marking pulse) or a no-current condition (spacing pulse). The intelligence elements are preceded by a start element (always spacing) and are followed by a stop element (always marking). The start and stop elements provide means for mechanical synchronization between the Multiple Wire Distributor and the receiving set.

c. The five level version of the Multiple Wire Distributor is designed to accommodate a 7.42 unit transmission pattern, while the eight level version will accommodate an 11.00 unit transmission pattern. Figure 2-1 illustrates both the 7.42 and 11.00 unit patterns, and the character arrangements for standard five level code.

2-3. MOTOR UNIT

NOTE

This paragraph does not apply if the Multiple Wire Distributor is receiving its motive power from an external source.

a. The initial starting current causes the start relay to pull up, and its contacts to close the auxiliary winding circuit (see Figure 2-2). As the rotor gains speed, the current flowing through the relay coil decreases. When a pre-determined current value is reached the relay armature is released, the relay contacts are opened, and the auxiliary winding circuit is disconnected from the line. The rotor continues to accelerate until it reaches synchronous speed (3600 RPM). The motor is wired so that the shaft rotates in a clockwise direction when viewed from the pinion end. (Refer to Paragraph 1-4. for technical data.)

b. The capacitor and thermal cut-out switch are located below the motor, mounted on the motor mounting bracket. The starting relay is mounted on the bracket assembly, and sits above the motor. The thermal cut-out switch is in series with both the main and the auxiliary windings. If excessive current is drawn by the motor for any reason, the switch will open the circuit and prevent possible damage to the motor. The switch may be manually reset by depressing the red button projecting upward through the motor mounting plate and motor shield.

CAUTION

Allow the motor to cool at least 5 minutes before manually resetting the thermal cut-out switch.

c. Two fans are located within the motor housing, one at each end of the rotor. The fans draw cooling air through the slots in the end bells, and exhaust it through the motor housing slots. Rubber vibration mounts isolate the motor from its mounting bracket. The mounts are held in the bracket by mounting straps. The motor shaft has a tapped hole which is used to mount the motor pinion gear. All motor shaft endplay is taken up by a spring washer which bears against the outer race of one of the bearings. The function of the motor shield is to isolate the cool air intakes from the hot air exhaust slots.

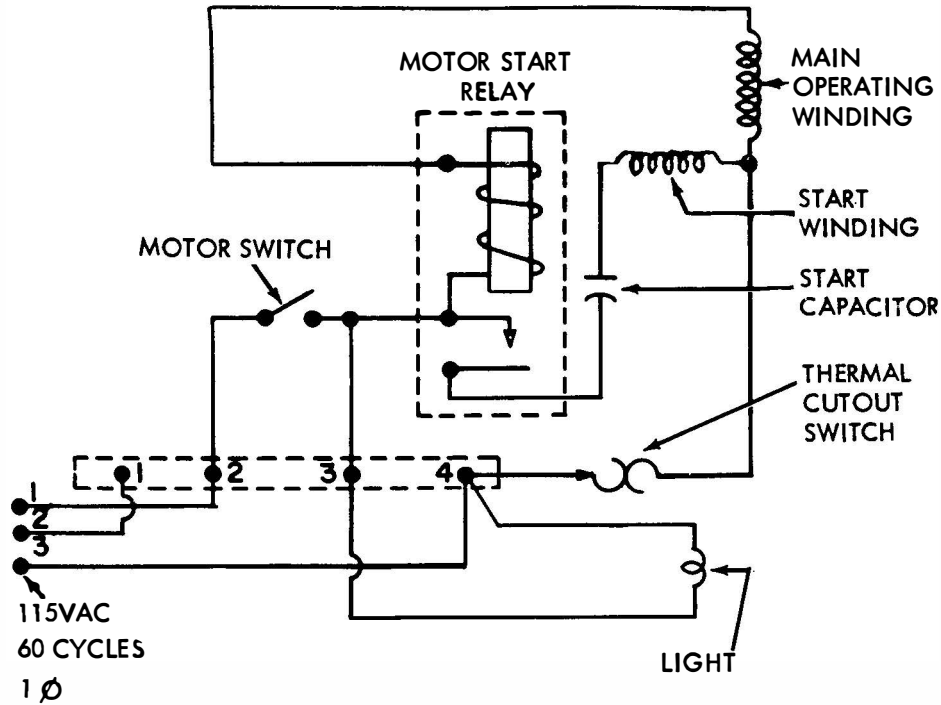

FIGURE 2-2. MOTOR UNIT

2-4. Multiple Wire Distributor Unit

a. Main Shaft Motion

(1) The main shaft receives its motive power from a gear mounted on the right side plate. The main shaft rotates continuously as long as the unit is under power.

(2) The clutch trip magnet mechanism controls the starting and stopping of the cam clutch assembly. From an idling condition in which the magnet is de-energized, clutch disengaged and start-stop contact closed, power is applied to the clutch magnet. When the magnet is energized, the armature is attracted and the armature bail disengages the latched trip lever. As the trip lever is moved by its spring, it disengages the clutch shoe release lever. This permits the clutch to engage and rotate the cam sleeve. The clutch assembly and the cam sleeve rotate continuously as long as the clutch magnets are energized.

(3) When the clutch magnet circuit is broken, the armature and bail assembly are returned to their original position by the armature spring. As the clutch assembly completes its revolution, the reset cam operates the reset lever to its original position. There it is latched by the armature bail assembly, and acts to block the clutch shoe release lever. As the clutch assembly and the attached cam sleeve come to rest, the latch lever drops into a notch on the clutch

disk assembly to hold the clutch disengaged until the clutch magnet is again energized.

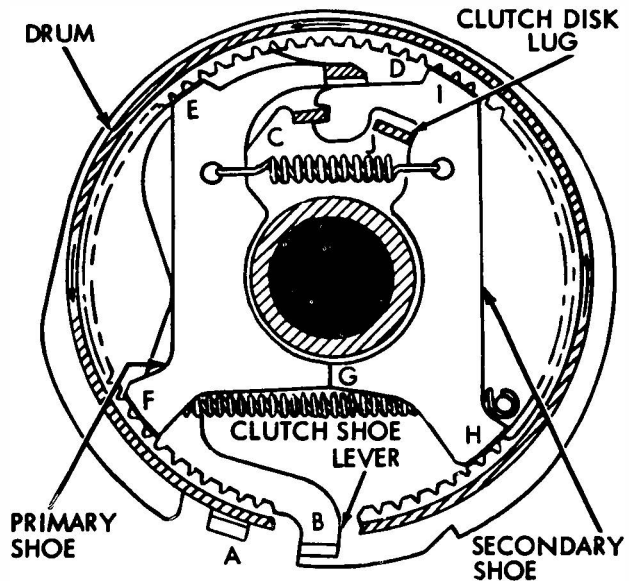

FIGURE 2-3. CLUTCH, ENGAGED

(4) Clutch engagement (Figure 2-3) is accomplished by releasing the lower end of the clutch shoe lever B. The upper end of the clutch shoe lever pivots about its ear C which bears against the upper end of the secondary shoe, and moves its ear D and the upper end of the primary shoe toward the right until the shoe

makes contact with the drum at point E. As the clutch drum turns clockwise, it drives the primary shoe downward so that it again makes contact with the drum, this time at point F. There, the combined forces acting on the primary shoe cause it to push against the secondary shoe at point G. The lower end of the shoe then bears against the drum at point H. The revolving drum acts to drive this shoe upward so that it again makes contact at point I. The forces involved are multiplied at each of the preceding stops. The aggregate force is applied through the shoes to the lug J on the clutch cam disk, and the disk and attached cam sleeve turn in unison with the drum.

(5) Disengagement (Figure 2-4) is effected when the lower end of shoe lever B

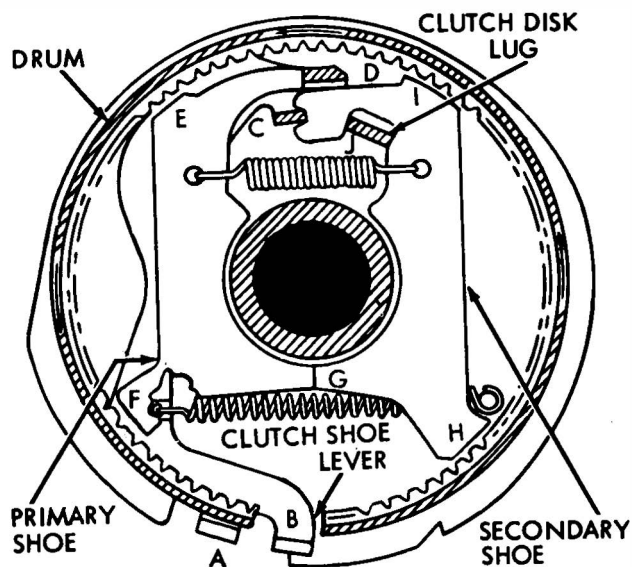

FIGURE 2-4. CLUTCH, DISENGAGED

strikes the trip lever. Lug A and the lower end of the shoe lever are brought together and the upper end of the lever B pivots about its ear C and allows its other ear D to move toward the left. The upper spring then pulls the two shoes together and away from the drum. The latch lever seats in the indent in the cam disk and the cam is held in its stop position until the clutch is again engaged. As the clutch completes its revolution, a reset cam by means of a reset lever returns the trip lever to its latched position.

b. Contact Mechanism

(1) Five Level LD Units - The contact arrangement in five level units consists of eight contacts (seven contacts in early design units), each of which has a contact lever and cam associated with it. Five of these contacts are for the intelligence elements of the signalling code, one is for the start-stop element, and two are for the auxiliary contacts (one auxiliary contact in early design units).

(2) Eight Level LD Units - The contact arrangement in eight level units consists of ten contacts each of which has a contact lever and cam associated with it. Eight of these contacts are for the intelligence elements of the signalling code, one for the start-stop element, and one is for the auxiliary contact.

(3) All LD Units - Each time the clutch is tripped, the cam sleeve rotates one complete revolution, and its individual cams actuate their respective contact levers in sequence. These contact levers control the opening and closing of the contacts for measured intervals of time. Operation of the distributor contacts generates sequential start-stop signal pattern corresponding to the code combinations from the external multi-wire source.

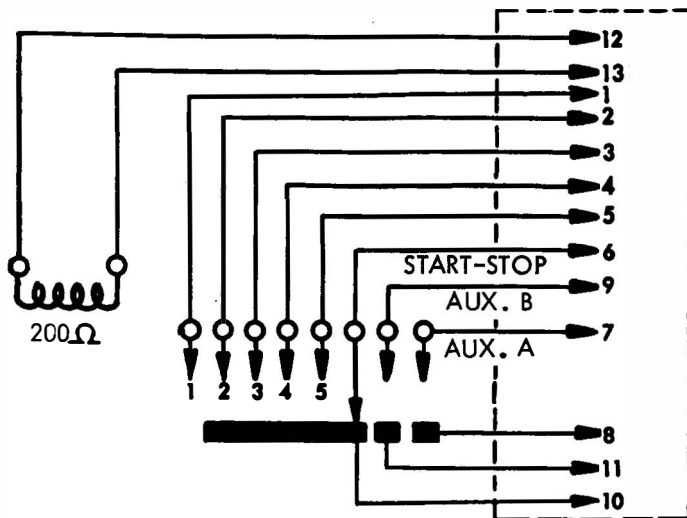

FIGURE 2-5 SCHEMATIC WIRING DIAGRAM: TYPICAL MULTIPLE WIRE DISTRIBUTOR UNIT

SECTION 3

ADJUSTMENTS AND SPRING TENSIONS

3-1. GENERAL

a. The information needed to adjust the Multiple Wire Distributor Unit, and Base and Motor Unit is contained in this section. Adjusting clearance, position of unit parts, point and angle of scale application and other pertinent information are indicated by the illustrations. Adjusting and spring tension requirements and procedures are included in the texts that accompany the illustrations.

b. The adjustments are arranged in the sequence that should be followed if complete readjustment of the unit is undertaken. Tools required to make these adjustments are not supplied as part of the equipment, but are listed in Teletype Bulletin 1124B. If a part mounted on shims is removed, the number of shims in each pile up should be noted so that identical pile ups can be made when the part is remounted. After an adjustment has been made, all nuts and screws that were loosened should be tightened.

c. All of the drawings in this section were drawn with respect to a five level unit. Eight level units differ only in the number of cams, contacts and associated parts.

d. The spring tension values given are those that should be obtained when Teletype

scales are used as shown in the illustrations.

<u>Scale</u>	<u>Teletype Part Number</u>
8 oz.	110443
32 oz.	110444

Replace springs that do not meet requirements, and for which there is no adjusting procedure.

e. In its disengaged position the clutch is latched between the clutch trip lever, which bears against the shoe lever and the clutch latch lever, which is seated in the notch in the clutch disk (see Figures 2-3 and 2-4). In this position, the clutch shoes (Figure 2-4) are not in contact with the clutch drum and the shaft may be rotated freely. When the shaft is turned by hand, the clutch does not fully disengage upon reaching its stop position. If a requirement calls for disengagement, rotate the clutch to its stop position, apply pressure with a screwdriver to the disk lug (Figure 2-3) and turn the disk in the normal direction of shaft rotation until the latch lever falls into its notch. When the clutch is engaged, the shoe lever is unlatched (Figure 2-3) and the shoes are wedged against the drum. This forces the clutch to turn with the shaft.

3-2 MULTIPLE WIRE DISTRIBUTOR UNIT ADJUSTMENTS - LATE DESIGN

CLUTCH TRIP ARMATURE AIR GAP

REQUIREMENT

AIR GAP BETWEEN ARMATURE AND MAGNET ASSEMBLY BRACKET:
MIN. 0.004 INCH --- MAX. 0.008 INCH
WHEN ARMATURE IS HELD FLUSH AGAINST MAGNET CORE.

TO ADJUST

REMOVE ARMATURE EXTENSION SPRING. LOOSEN SPRING POST AND HINGE MOUNTING SCREW AND POSITION HINGE.

NOTE: TO ELIMINATE CHATTER AND AC HUM IN AC OPERATION, REVERSE THE ARMATURE (SIDE STAMPED "C" FACING AWAY FROM MAGNET CORE) BY REMOVING THE MOUNTING SCREWS AND ARMATURE BAIL.

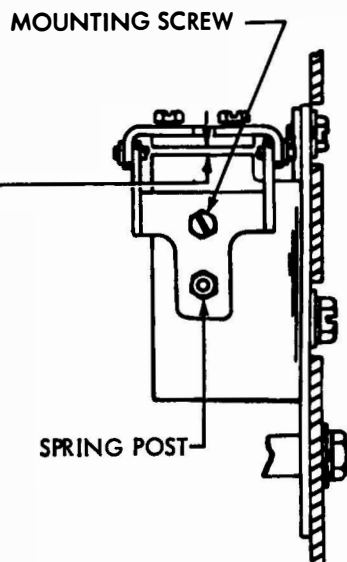

PLATE MOUNTING SCREW

PLATE ADJUSTING SCREW

CLUTCH TRIP LEVER

REQUIREMENT

CLEARANCE BETWEEN ARMATURE EXTENSION LEVER AND LATCHING SURFACES OF CLUTCH TRIP LEVER:
MIN. 0.020 INCH --- MAX. 0.030 INCH
WHEN CLUTCH TRIP LEVER IS ON HIGH PART OF CAM (PLAY TAKEN UP WITH SPRING).

TO ADJUST

LOOSEN PLATE ADJUSTING SCREW AND PLATE MOUNTING SCREW. INSERT SCREWDRIVER IN SLOT ADJACENT TO ADJUSTING SCREW AND POSITION PLATE FOR REQUIRED CLEARANCE.

BRACKET MOUNTING SCREW

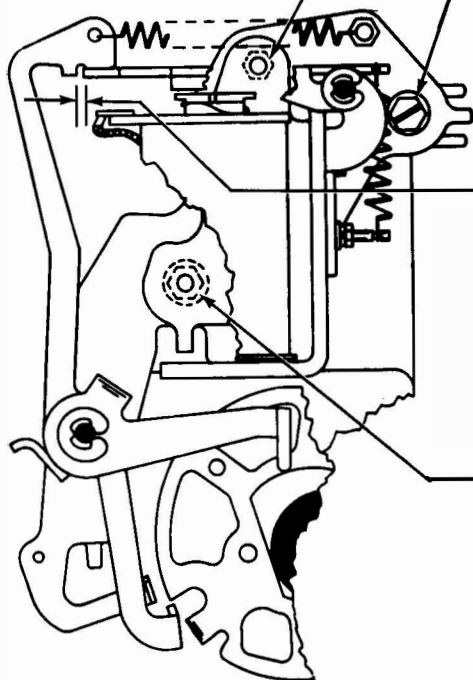
ARMATURE EXTENSION

REQUIREMENT

CLEARANCE BETWEEN ARMATURE EXTENSION LEVER AND CLUTCH TRIP LEVER
MIN. 0.030 INCH --- MAX. 0.040 INCH
WHEN CLUTCH TRIP LEVER IS ON HIGH PART OF CAM AND ARMATURE IS FLUSH AGAINST CORE (PLAY TAKEN UP WITH SPRING).

TO ADJUST

LOOSEN BRACKET MOUNTING SCREW AND PLATE ADJUSTING SCREW AND INSERT SCREWDRIVER INTO SLOT BELOW ADJUSTING SCREW, AND ADJUST BRACKET.

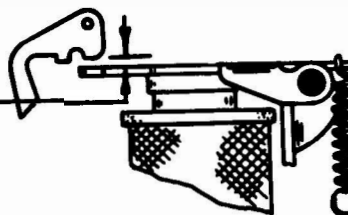

3-2 MULTIPLE WIRE DISTRIBUTOR UNIT ADJUSTMENT - LATE DESIGN (CONTINUED)

CLUTCH TRIP CLAMPING SCREW

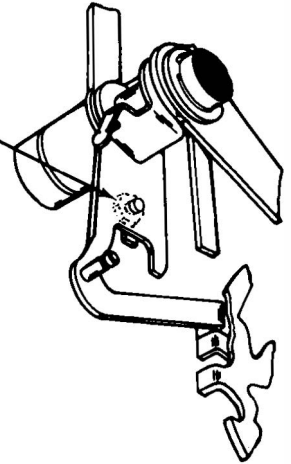

CLUTCH STOP ARM

REQUIREMENT

WITH CLUTCH TRIP LEVER IN LATCHED POSITION, CLUTCH LEVER SHOULD FULLY ENGAGE CLUTCH SHOE LEVER.

TO ADJUST

WITH CLUTCH IN STOP POSITION, LOOSEN CLUTCH TRIP CLAMPING SCREW AND ADJUST CLUTCH STOP LEVER TO OBTAIN FULL BITE WITH CLUTCH SHOE LEVER.

NOTE: WHEN ARMATURE IS IN ATTRACTED POSITION, CLUTCH STOP ARM SHOULD CLEAR STOP LEVER AND STOP LUG BY AT LEAST SOME CLEARANCE.

CLUTCH SHOE LEVER

REQUIREMENT

CLEARANCE BETWEEN CLUTCH SHOE LEVER AND EXTENSION SHOULD BE MIN. 0.055 INCH --- MAX. 0.085 INCH GREATER WHEN CLUTCH IS ENGAGED THAN WHEN DISENGAGED.

TO ADJUST

LOOSEN TWO CLAMP SCREWS IN CLUTCH DISK. ROTATE ADJUSTING DISK TO OBTAIN PROPER CLEARANCE.

NOTE: AFTER ABOVE ADJUSTMENT IS MADE, DISENGAGE CLUTCH AND ROTATE DRUM IN NORMAL ROTATION TO MAKE CERTAIN IT DOES NOT DRAG ON SHOES. IF DRUM DRAGS, REFINE ADJUSTMENT.

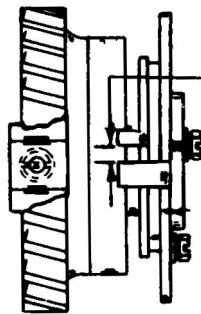

CAM FOLLOWER GUIDE

CAM FOLLOWER

CAMS

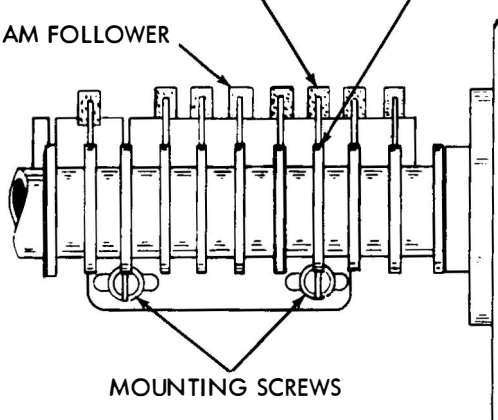

MOUNTING SCREWS

CAM FOLLOWER GUIDE

REQUIREMENT

CAM FOLLOWER GUIDE ORIENTED SO CENTER CAM FOLLOWER IS FULLY ON CAM WHEN FOLLOWER IS MOVED SIDWAYS IN GUIDE SLOT. OTHER MUST HAVE AT LEAST 75% BITE WHEN MOVED IN EITHER DIRECTION, AND BE FREE IN THEIR GUIDE SLOTS.

TO ADJUST

POSITION CAM FOLLOWER GUIDE WITH ITS MOUNTING SCREWS LOOSENED. AFTER TIGHTENING, CHECK FOR FREENESS.

3-2 MULTIPLE WIRE DISTRIBUTOR UNIT ADJUSTMENT - LATE DESIGN (CONTINUED)

DISTRIBUTOR BLOCK ASSEMBLY

DISTRIBUTOR BLOCK ASSEMBLY

REQUIREMENT

DISTRIBUTOR BLOCK ASSEMBLY POSITIONED ON CASTING SO THAT ROCKER LEVERS ARE FULLY ENGAGED WITH THE BAKELITE ON THE FOLLOWER LEVERS.

TO ADJUST

LOOSEN DISTRIBUTOR BLOCK ASSEMBLY MOUNTING SCREWS AND POSITION BLOCK LEFT OR RIGHT TO OBTAIN REQUIREMENT.

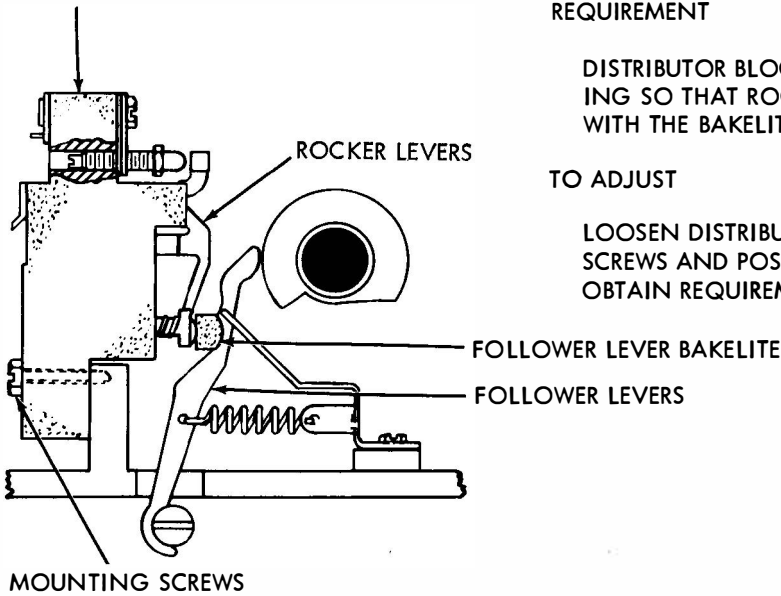

DISTRIBUTOR CONTACT GAP

REQUIREMENT

CONTACT GAP SHOULD BE
MIN. 0.020 INCH --- MAX. 0.030 INCH
WITH CAM FOLLOWER LEVER ON HIGH PART OF CAM.

TO ADJUST

TURN CONTACT SCREW AT SOCKET END UNTIL DESIRED GAP IS OBTAINED.
CHECK ALL CONTACT GAPS.

NOTE: POSITION FOLLOWER ON HIGH OF CAM BY TRIPPING CLUTCH MANUALLY AND ROTATING DISTRIBUTOR SHAFT.

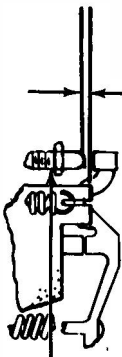

CONTACT SCREW

3. SPRING TENSIONS

CLUTCH SHOE LEVER

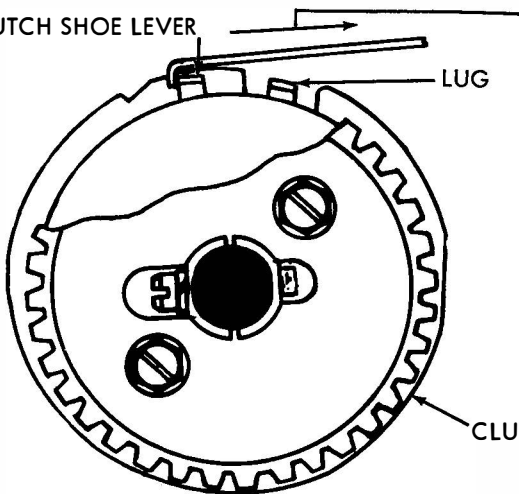

CLUTCH SHOE LEVER SPRING

REQUIREMENT

CLUTCH ENGAGED. CLUTCH DISK HELD TO PREVENT ITS TURNING:
MIN. 15 OZS. --- MAX. 20 OZS.
TO PULL SHOE LEVER IN CONTACT WITH LUG ON CLUTCH DISK.

3-2 MULTIPLE WIRE DISTRIBUTOR UNIT ADJUSTMENT - LATE DESIGN (CONTINUED)

NOTE

AS IT REQUIRES REMOVAL OF CLUTCH FROM SHAFT, THIS SPRING TENSION SHOULD NOT BE CHECKED UNLESS THERE IS GOOD REASON TO SUSPECT THAT IT WILL NOT MEET ITS REQUIREMENT.

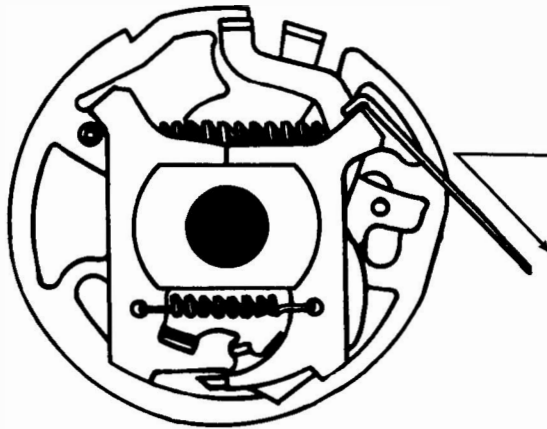
CLUTCH SHOE SPRING

REQUIREMENT
CLUTCH DRUM REMOVED.
MIN. 3 OZS. --- MAX. 5 OZS.
TO START PRIMARY SHOE MOVING AWAY FROM
SECONDARY SHOE.

DISTRIBUTOR CAM FOLLOWER SPRING

REQUIREMENT
DISTRIBUTOR BLOCK REMOVED
MIN. 1/2 OZ. --- MAX. 1-1/2 OZ.
TO START CAM FOLLOWER LEVER MOVING WHEN
LEVER IS ON HIGH OF CAM.

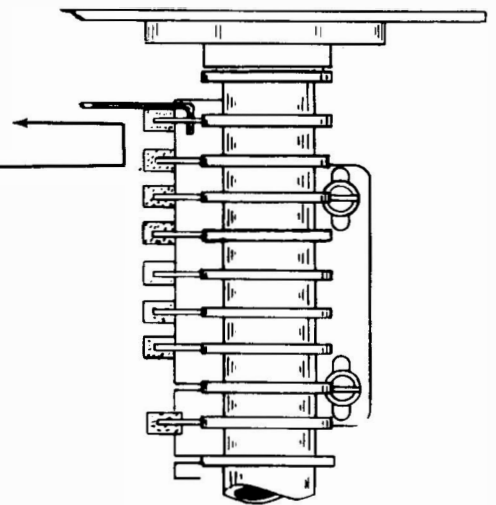

3-2 MULTIPLE WIRE DISTRIBUTOR UNIT ADJUSTMENT - LATE DESIGN (CONTINUED)

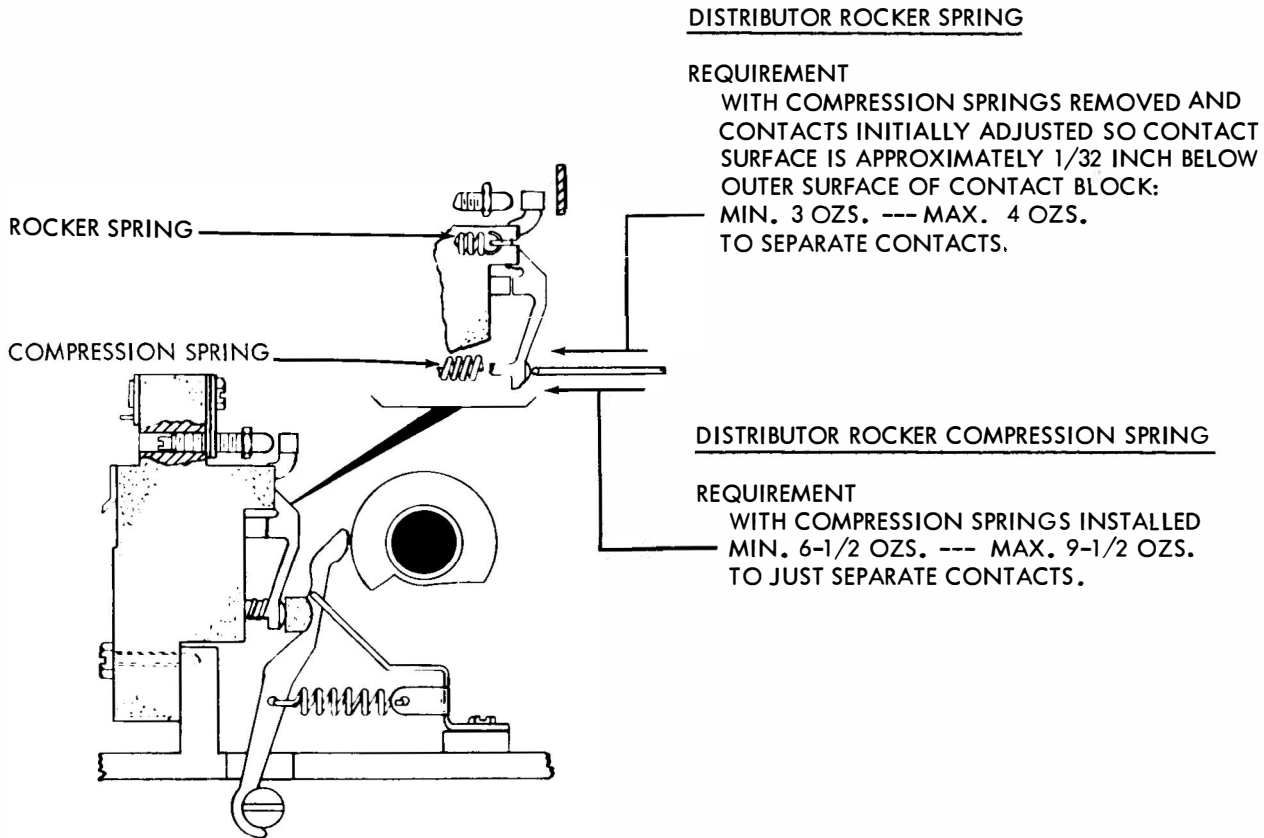

3-2 MULTIPLE WIRE DISTRIBUTOR UNIT ADJUSTMENT - LATE DESIGN (CONTINUED)

CLUTCH LATCH LEVER SPRING

REQUIREMENT
 CLUTCH LATCH LEVER ON LOW OF CLUTCH DISK (BUT NOT LATCHED)
 MIN. 2-1/2 OZS. --- MAX. 4-1/2 OZS.
 TO START LATCH LEVER MOVING.

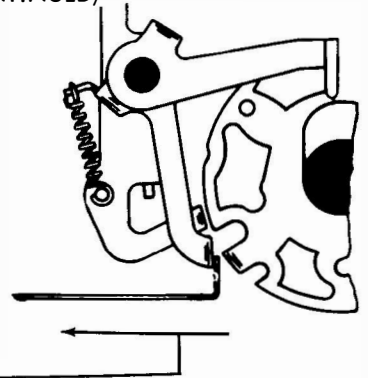

CLUTCH TRIP LEVER SPRING

REQUIREMENT
 CLUTCH TRIPPED AND ARMATURE HELD AGAINST MAGNET CORE
 MIN. 2 OZS. --- MAX. 3-1/2 OZS.
 TO START TRIP LEVER MOVING.

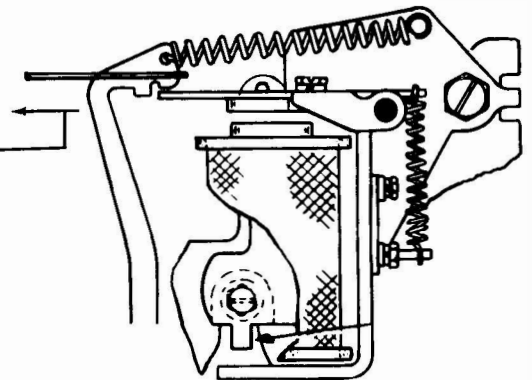

CLUTCH MAGNET ARMATURE BAIL SPRING

REQUIREMENT
 CLUTCH MAGNET TRIPPED AND SHAFT ROTATED MANUALLY
 UNTIL TRIP FOLLOWER IS ON HIGH OF CAM.
 MIN. 3 OZS --- MAX. 4-1/2 OZS.
 TO START ARMATURE EXTENSION LEVER MOVING.

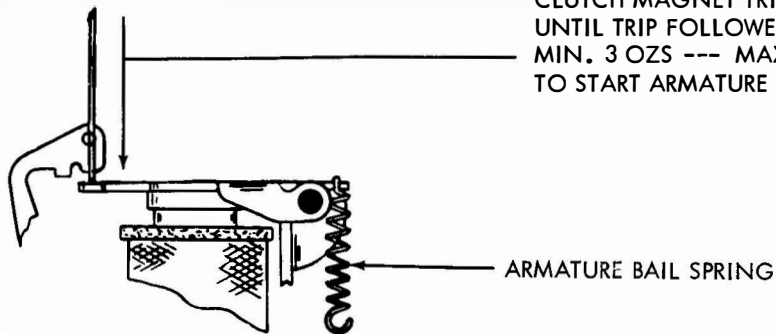

3-2 MULTIPLE WIRE DISTRIBUTOR UNIT ADJUSTMENT - LATE DESIGN (CONTINUED)

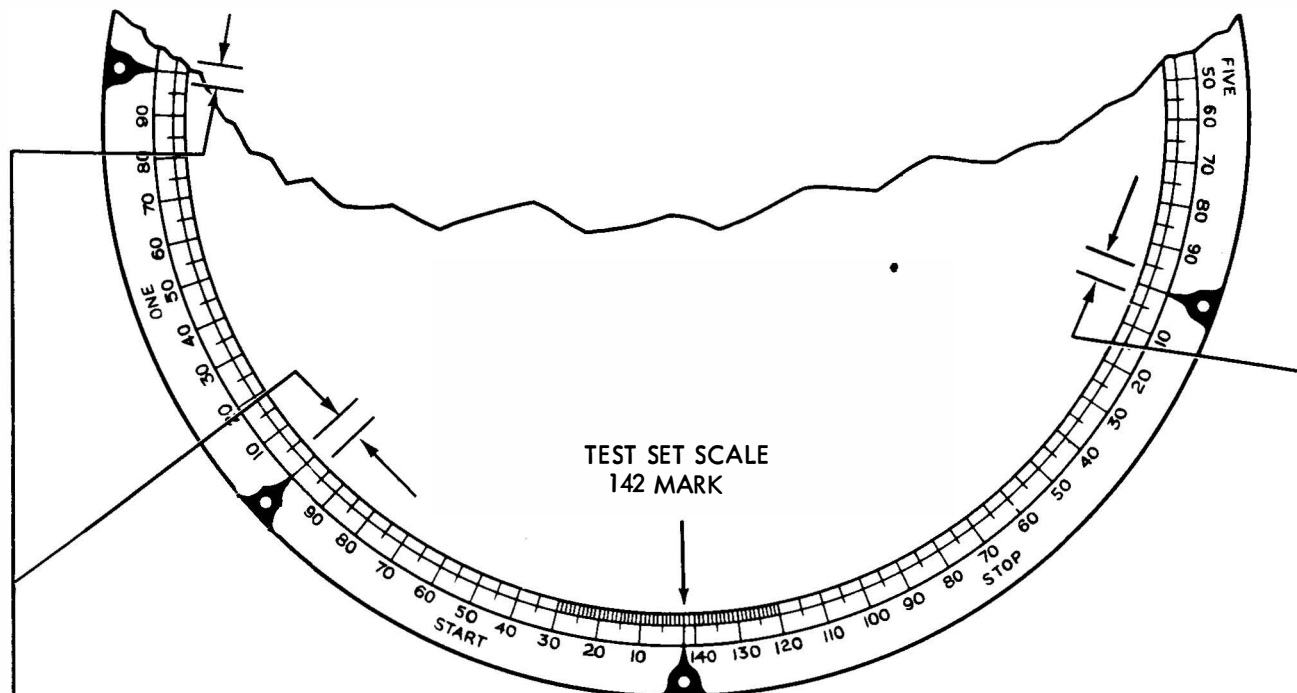

SIGNAL PULSE (FINAL ADJUSTMENT WITH DXD OR STROBE)

NOTE 1 --- FOR OPERATION OF THE SIGNAL DISTORTION TEST SET (DXD) REFER TO TELETYPE BULLETIN 181B.

PROCEDURE

CONNECT STROBE OF TEST SET ACROSS EACH CONTACT OF DISTRIBUTOR IN TURN TO VIEW PULSE IMAGE GENERATED BY THAT CONTACT OF DISTRIBUTOR. TRIP CLUTCH TRIP MAGNET AND HOLD DOWN BY REMOVING ARMATURE SPRING. ALIGN END OF STOP PULSE IMAGE GENERATED BY DISTRIBUTOR WITH 142 MARK ON TEST SET SCALE BY ROTATING SCALE.

NOTE 2 --- TEST SET AND DISTRIBUTOR MUST BE OPERATING AT SAME SPEED (60, 75 OR 100 WPM).

(1) REQUIREMENT (5 LEVEL, 7.42 UNIT CODE TRANSMISSION, AND 7.42 UNIT CODE TEST SET SCALE)

1. THERE SHALL BE NO BREAKS IN THE TRANSMITTED SIGNAL PULSES.
2. EACH MARKING PULSE SHOULD LIE IN ITS RESPECTIVE SEGMENT ON THE TEST SCALE WITHIN ± 3 DIVISIONS AT EACH END.
3. THE STOP PULSE SHOULD START WITHIN ± 3 DIVISIONS OF THE 0 MARK AND END ON #142.
4. AUXILIARY CONTACTS
 - A. UNITS EQUIPPED WITH NORMALLY OPEN CONTACTS

CONTACT "A" --- START ON #32 IN START SEGMENT (± 15 DIVISIONS) AND STOP ON #29 IN STOP SEGMENT (± 15 DIVISIONS.)

CONTACT "B" --- START ON #25 IN SEGMENT ONE (± 15 DIVISIONS) AND STOP ON #75 SEGMENT FIVE (± 15 DIVISIONS)
 - B. UNITS EQUIPPED WITH SIMULATED BREAK-MAKE CONTACTS

CONTACT "A" --- START ON #78 IN START SEGMENT (± 3 DIVISIONS) AND STOP ON #12 IN STOP SEGMENT (± 3 DIVISIONS)

CONTACT "B" --- START ON #18 IN STOP SEGMENT (± 3 DIVISIONS) AND STOP ON #72 IN START SEGMENT (± 3 DIVISIONS)

(2) REQUIREMENT (8 LEVEL, 11.00 UNIT CODE TRANSMISSION, AND 7.42 UNIT CODE TEST SET SCALE)

1. THERE SHALL BE NO BREAKS IN THE TRANSMITTED SIGNAL PULSES.

FIGURE 3-7 SIGNAL PULSE REFINEMENT

3-2 MULTIPLE WIRE DISTRIBUTOR UNIT ADJUSTMENT - LATE DESIGN (CONTINUED)

2. EACH MARKING PULSE SHOULD BE IN THE RANGE GIVEN IN THE TABLE BELOW WITHIN ± 2 DIVISIONS
3. THE STOP PULSE SHOULD START WITHIN ± 4 DIVISIONS OF THE #7 IN THE STOP SEGMENT AND END ON #142 OF THE STOP SEGMENT

CODE PULSE	BEGIN		END	
	DIVISION	SEGMENT	DIVISION	SEGMENT
START	142	STOP	67	START
0	67	START	35	ONE
1	35	ONE	2	TWO
2	2	TWO	70	TWO
3	70	TWO	37	THREE
4	37	THREE	5	FOUR
5	5	FOUR	72	FOUR
6	72	FOUR	40	FIVE
7	40	FIVE	7	STOP
STOP	7	STOP	142	STOP

4. THE AUXILIARY CONTACT PULSE SHOULD START ON #32 IN START SEGMENT (± 15 DIVISIONS) AND STOP ON #29 IN STOP SEGMENT (± 15 DIVISIONS).
- (3) REQUIREMENT (8 LEVEL, 11.00 UNIT CODE TRANSMISSION, AND 11.00 UNIT CODE TEST SET SCALE)
1. THERE SHALL BE NO BREAKS IN THE TRANSMITTED SIGNAL PULSES.
 2. EACH MARKING PULSE SHOULD LIE IN ITS RESPECTIVE SEGMENT ON THE TEST SCALE WITHIN ± 3 DIVISIONS AT EACH END.
 3. THE STOP PULSE SHOULD START WITHIN ± 3 DIVISIONS OF THE 0 MARK OF ITS SEGMENT AND END ON #200.
 4. THE AUXILIARY CONTACT PULSE SHOULD START ON #30 IN START SEGMENT (± 15 DIVISIONS) AND STOP ON #30 IN STOP SEGMENT (± 15 DIVISIONS).

NOTE 3 — IN ORDER TO DETERMINE THE END OF THE NUMBER 7 PULSE IMAGE, HOLD THE STOP CONTACT OPEN.

TO ADJUST

REFINE DISTRIBUTOR CONTACT GAP, DISTRIBUTOR ROCKER SPRING, AND DISTRIBUTOR ROCKER COMPRESSION SPRING ADJUSTMENTS.

3-3 MULTIPLE WIRE DISTRIBUTOR UNIT ADJUSTMENTS - EARLY DESIGN

NOTE:

TO FACILITATE ITS ADJUSTMENT, UNIT SHOULD BE REMOVED FROM BASE.

THE FOLLOWING ADJUSTMENTS APPLY FOR 60, 75 AND 100 WORD PER MINUTE OPERATION UNLESS IT IS STATED OTHERWISE IN SPECIFIC ADJUSTING INSTRUCTIONS.

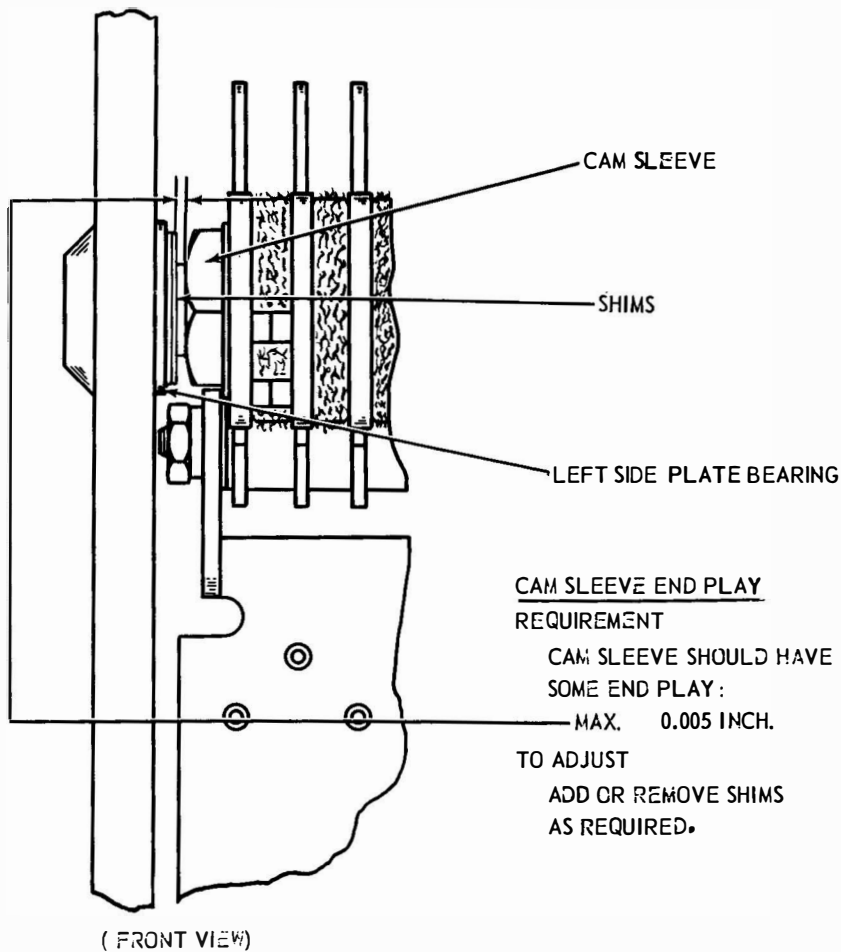

FIGURE 3-8 MAIN SHAFT MECHANISM

3-3 MULTIPLE WIRE DISTRIBUTOR UNIT ADJUSTMENTS (EARLY DESIGN) - CONTINUED

CLUTCH LATCH LEVER SPRING

REQUIREMENT

LATCH LEVER RESTING AGAINST LUG ON CLUTCH DISK.
 MIN. 1 O. — MAX. 2 OZS.
 TO START LATCH LEVER MOVING.

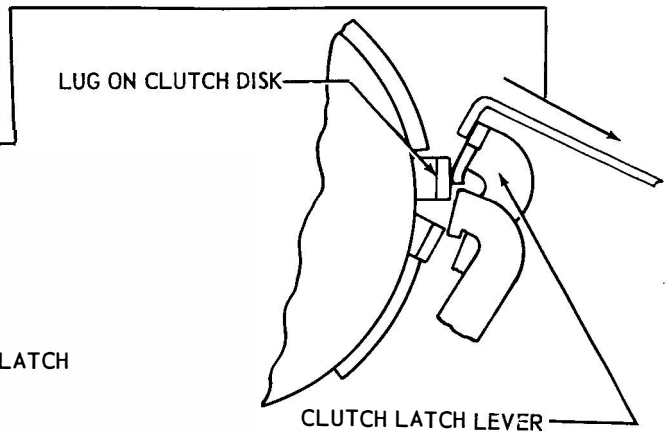

CLUTCH TRIP LEVER SPRING

TO CHECK

DISENGAGE CLUTCH. PULL ARMATURE FORWARD AGAINST POLE PIECES TO UNLATCH TRIP LEVER. HOLD ARMATURE AGAINST POLE PIECES AND MEASURE TENSION.

REQUIREMENT

MIN. 5 OZS. — MAX. 8 OZS.
 TO START LEVER MOVING.

MAGNET BRACKET

REQUIREMENT

ARMATURE SPRING UNHOOKED. MAGNETS ENERGIZED WITH A DIRECT CURRENT OF 0.025 AMPERES.

- (1) ARMATURE SHOULD CONTACT BOTH POLE PIECES.
- (2) MEASURED AT THE CLOSEST POINT, THERE SHOULD BE SOME CLEARANCE BETWEEN ARMATURE BAIL AND CLUTCH TRIP LEVER:

MAX. 0.006 INCH

TO ADJUST

POSITION MAGNET BRACKET WITH TWO MOUNTING SCREWS FRICTION TIGHT.

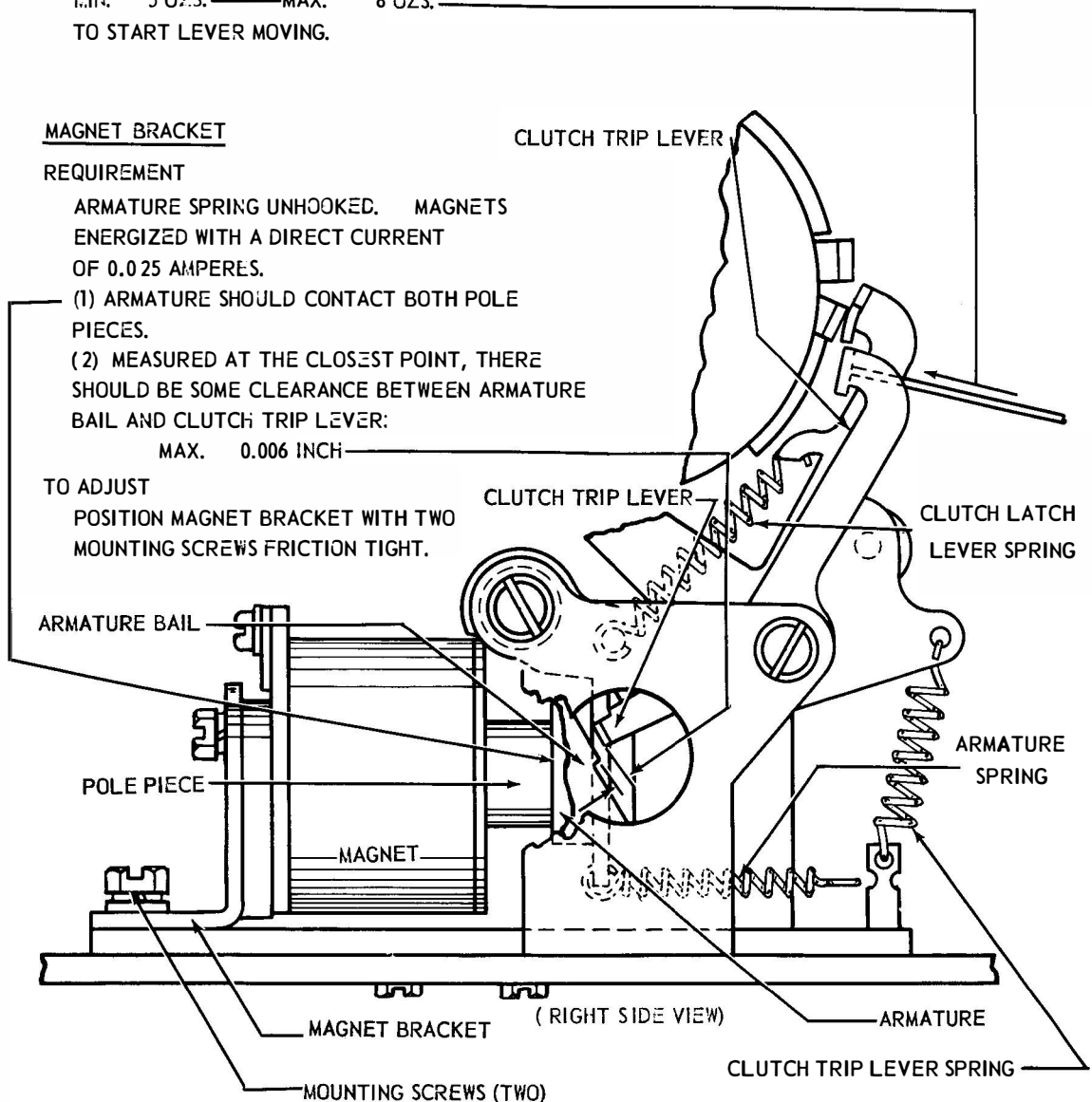

FIGURE 3-9 CLUTCH TRIP MAGNET MECHANISM

3-3 MULTIPLE WIRE DISTRIBUTOR UNIT ADJUSTMENTS (EARLY DESIGN) - CONTINUED

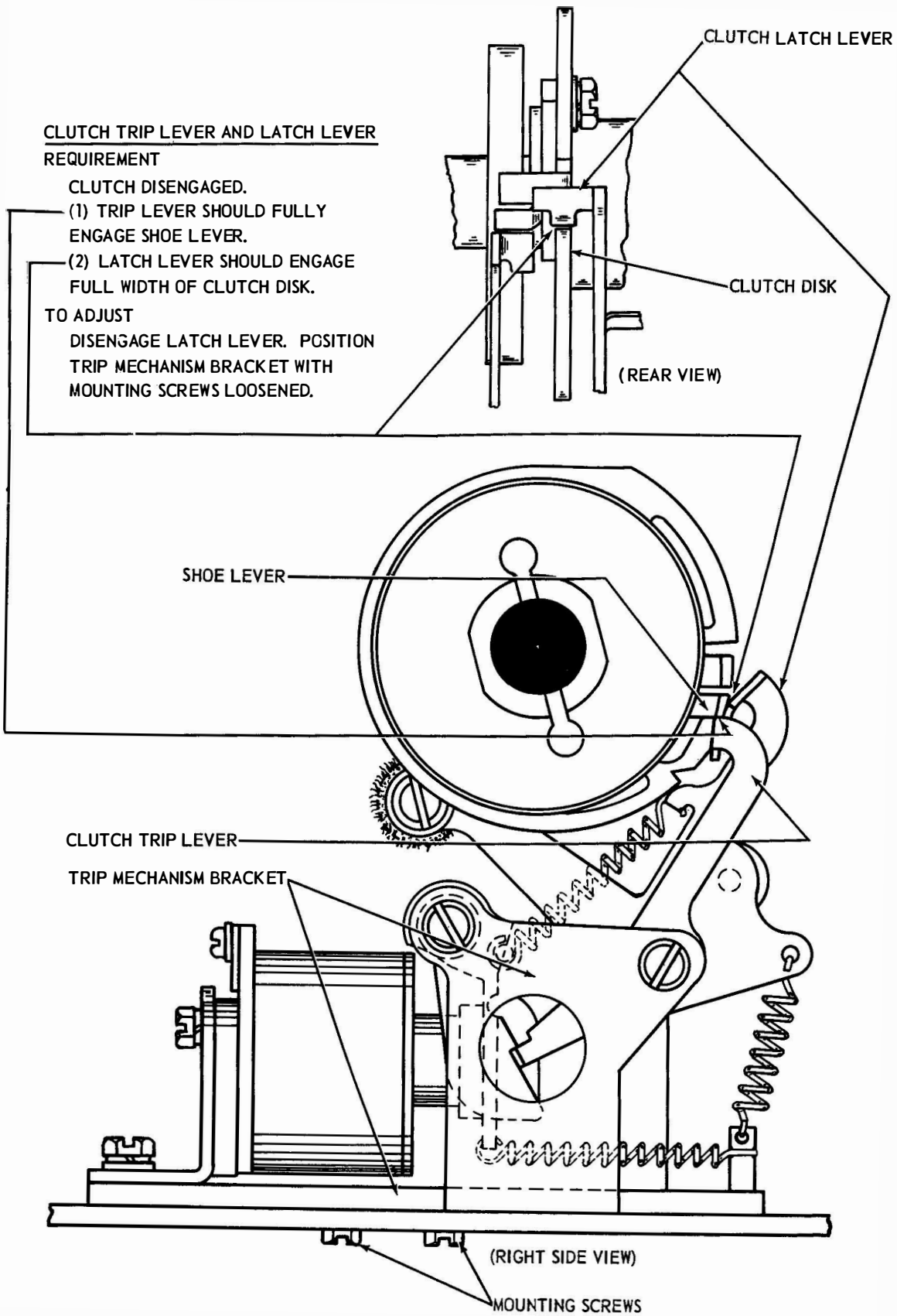

FIGURE 3-10 CLUTCH TRIP MAGNET MECHANISM

3-3 MULTIPLE WIRE DISTRIBUTOR UNIT ADJUSTMENTS (EARLY DESIGN) - CONTINUED

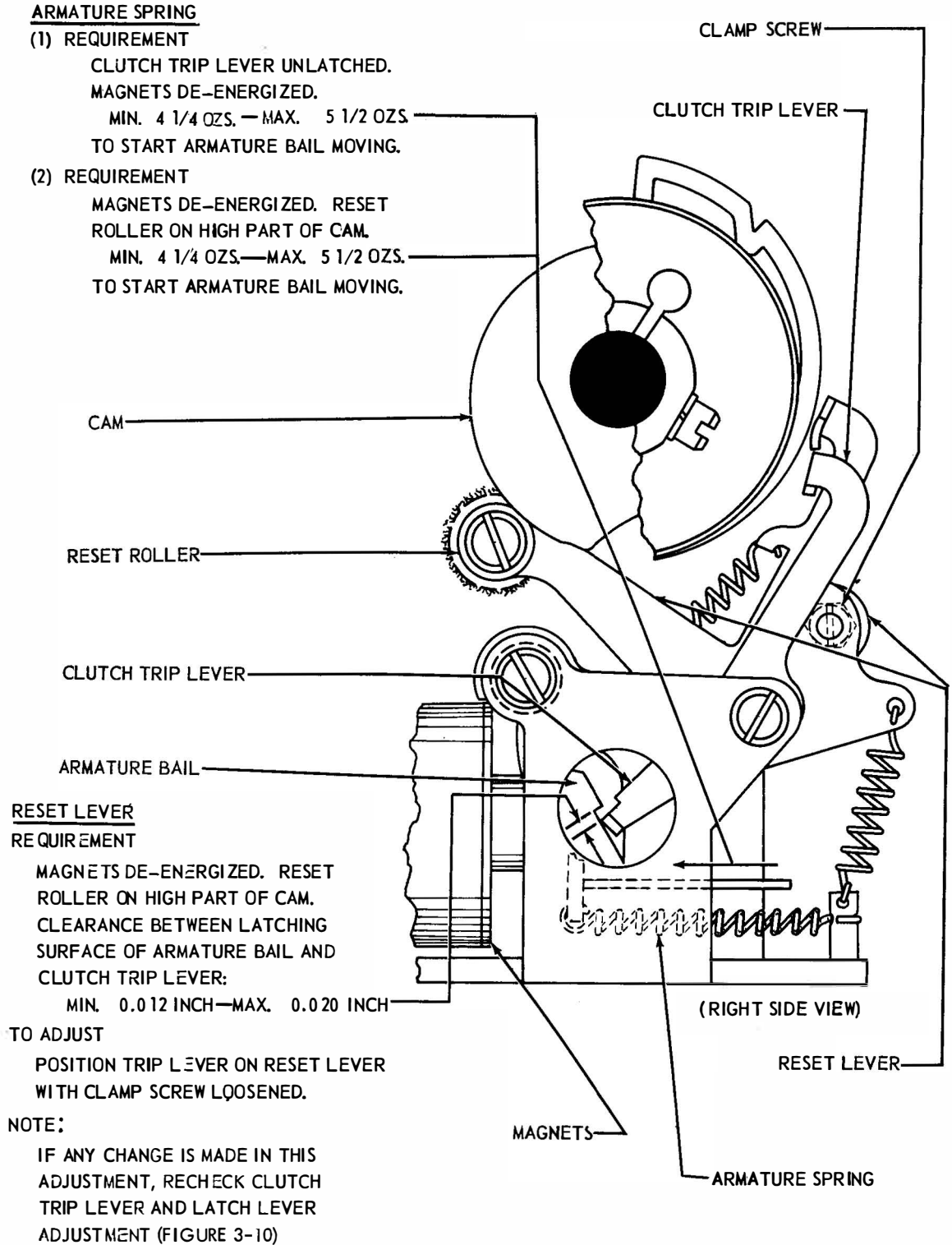

FIGURE 3-11 CLUTCH TRIP MAGNET MECHANISM

3-3 MULTIPLE WIRE DISTRIBUTOR UNIT ADJUSTMENTS (EARLY DESIGN) - CONTINUED

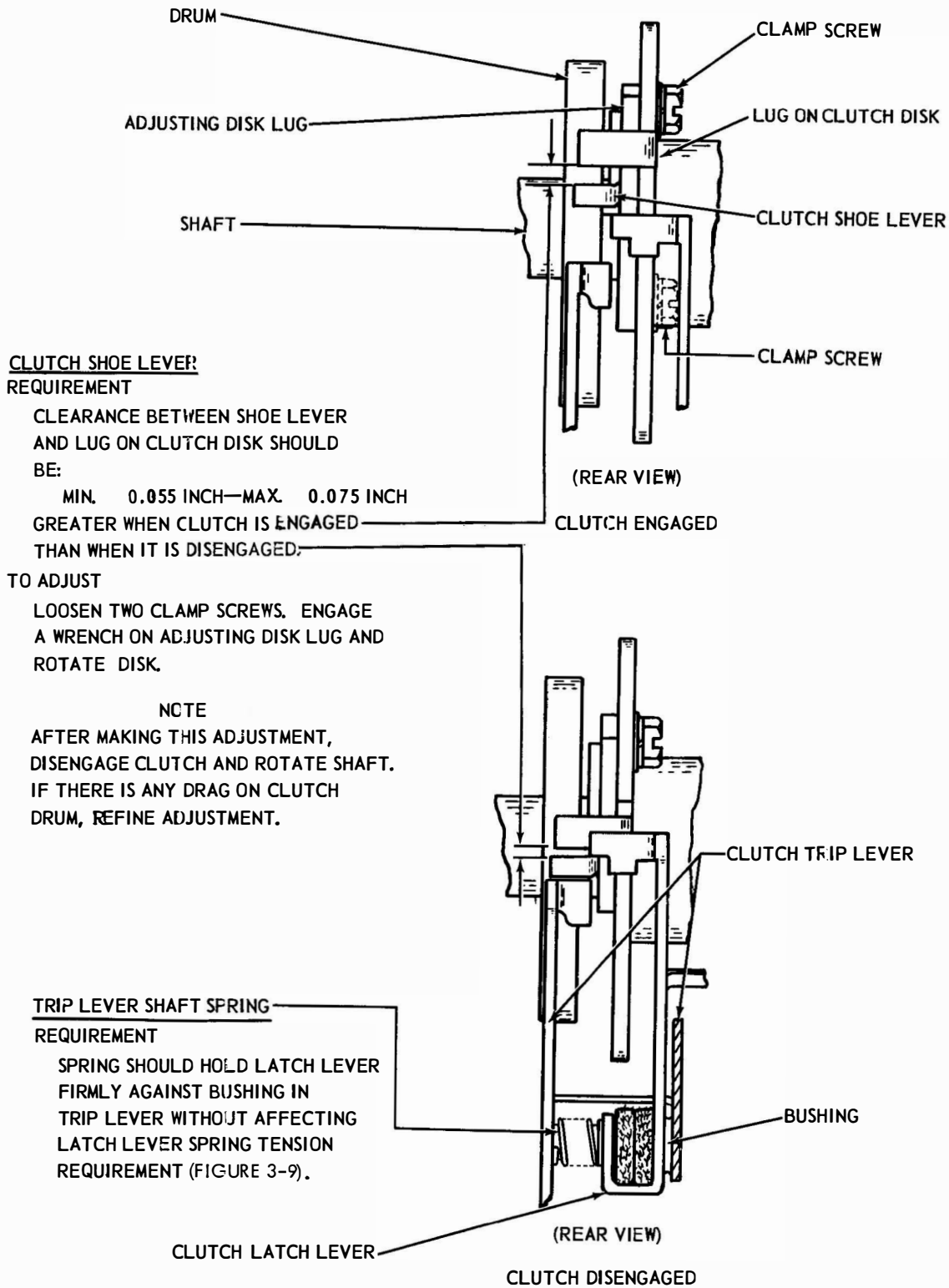

FIGURE 3-12 CLUTCH AND TRIP MECHANISM

3-3 MULTIPLE WIRE DISTRIBUTOR UNIT ADJUSTMENTS (EARLY DESIGN) - CONTINUED

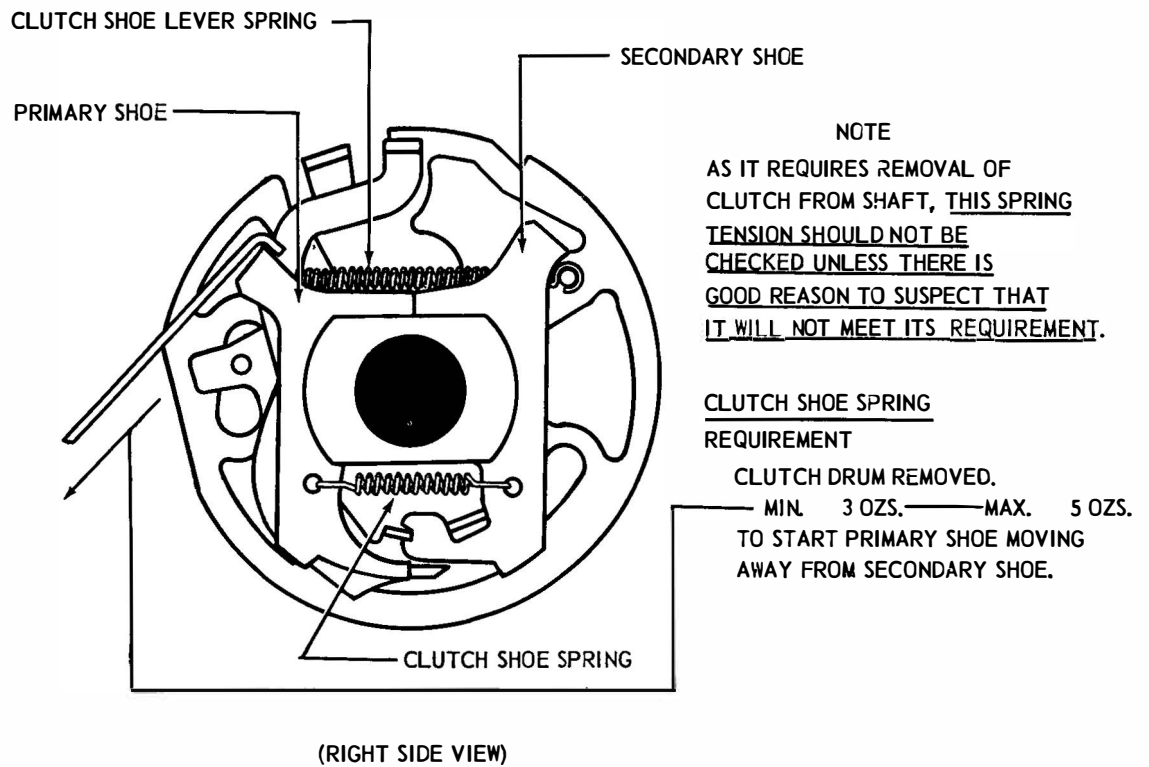
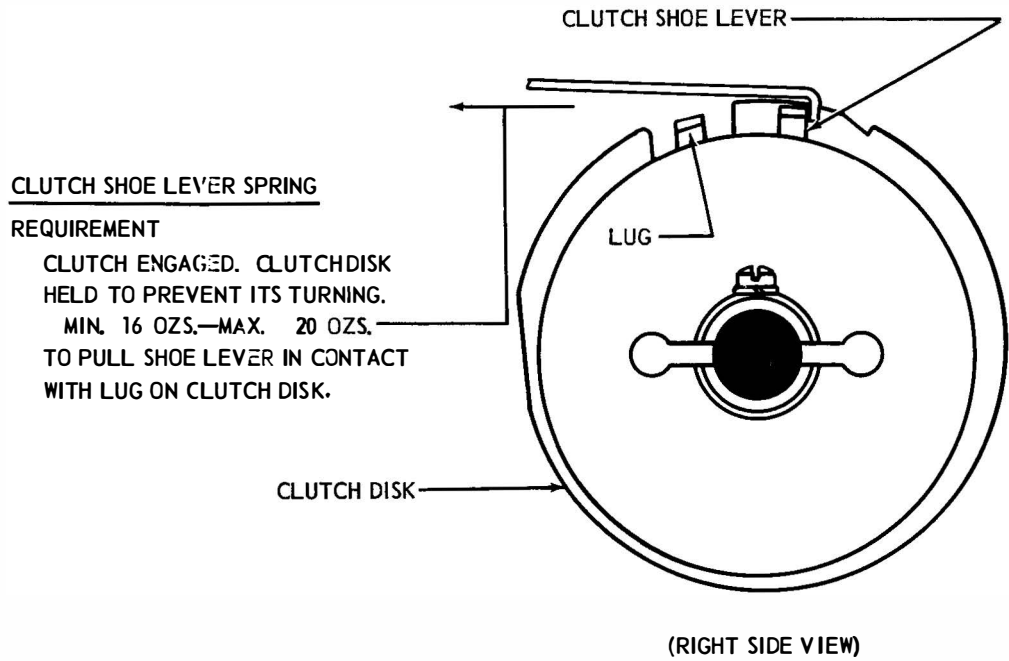

FIGURE 3 13 CLUTCH

3-3 MULTIPLE WIRE DISTRIBUTOR UNIT ADJUSTMENTS (EARLY DESIGN) - CONTINUED

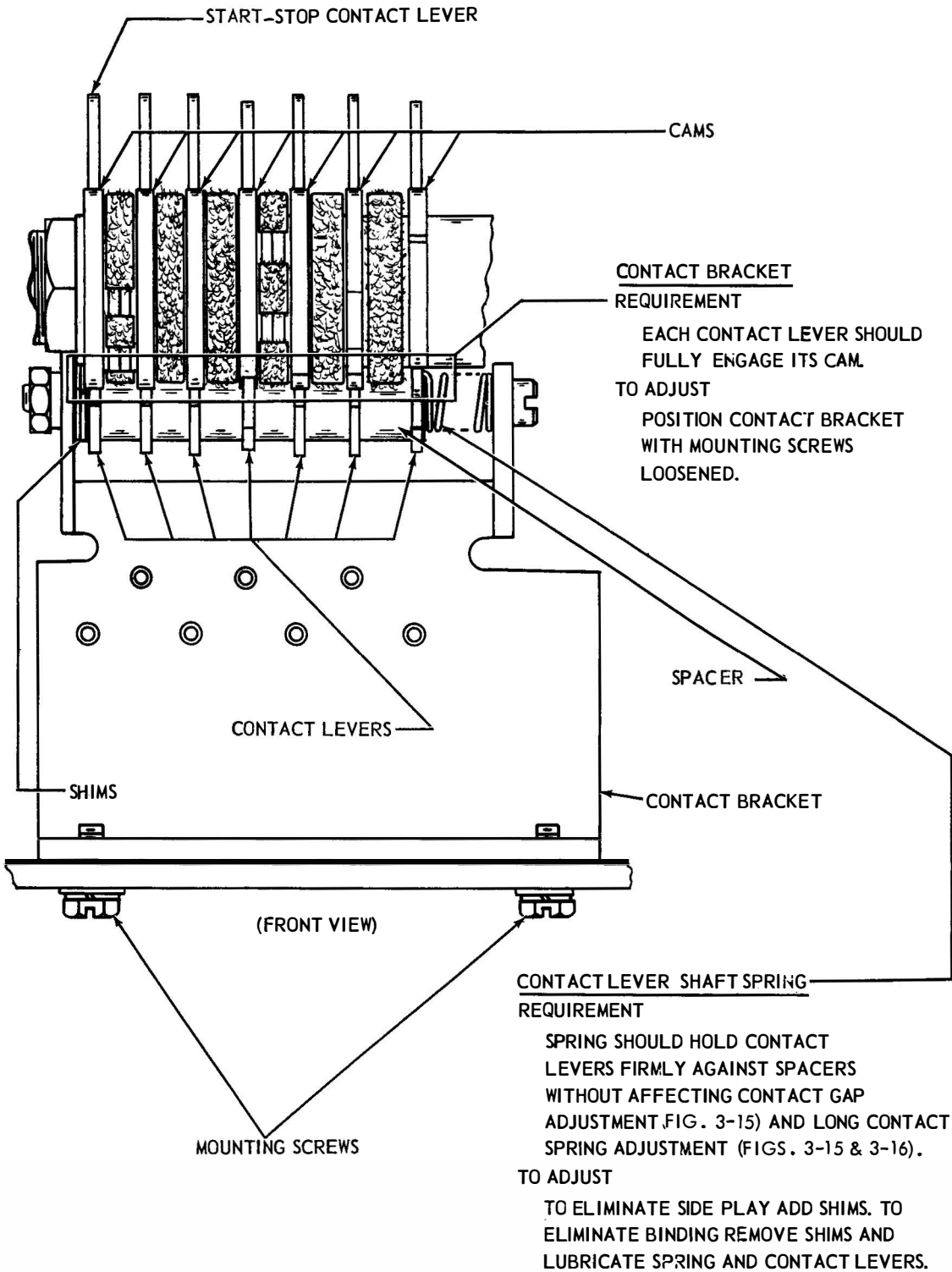

FIGURE 3-14 CONTACT MECHANISM

3-3 MULTIPLE WIRE DISTRIBUTOR UNIT ADJUSTMENTS (EARLY DESIGN) - CONTINUED

NOTE

THESE ADJUSTMENTS SHOULD BE MADE FOR EACH OF THE SEVEN CONTACTS ON DISTRIBUTOR.

CONTACT GAP AND SHORT CONTACT SPRING

(1) REQUIREMENT

SHORT CONTACT SPRING SHOULD REST AGAINST ITS STOP SCREW WITH PRESSURE OF:

MIN. 4 OZS. — MAX. 8 OZS.

(2) REQUIREMENT

CONTACT LEVER ON HIGH PART OF CAM. ASSOCIATED CONTACT GAP SHOULD BE:

MIN. 0.017 INCH — MAX. 0.023 INCH

START-STOP CONTACT GAP SHOULD BE:

MIN. 0.015 INCH — MAX. 0.025 INCH

(FOR LOCATION OF START-STOP CONTACT LEVER SEE FIGURE 3-14.)

TO ADJUST

BACK OFF STOP SCREW ALL THE WAY. BEND SHORT CONTACT SPRING SO THAT IT MEETS REQUIREMENT (1). POSITION STOP SCREW SO THAT GAP MEETS REQUIREMENT (2). RECHECK SHORT SPRING PRESSURE. REFINE ADJUSTMENT IF NECESSARY.

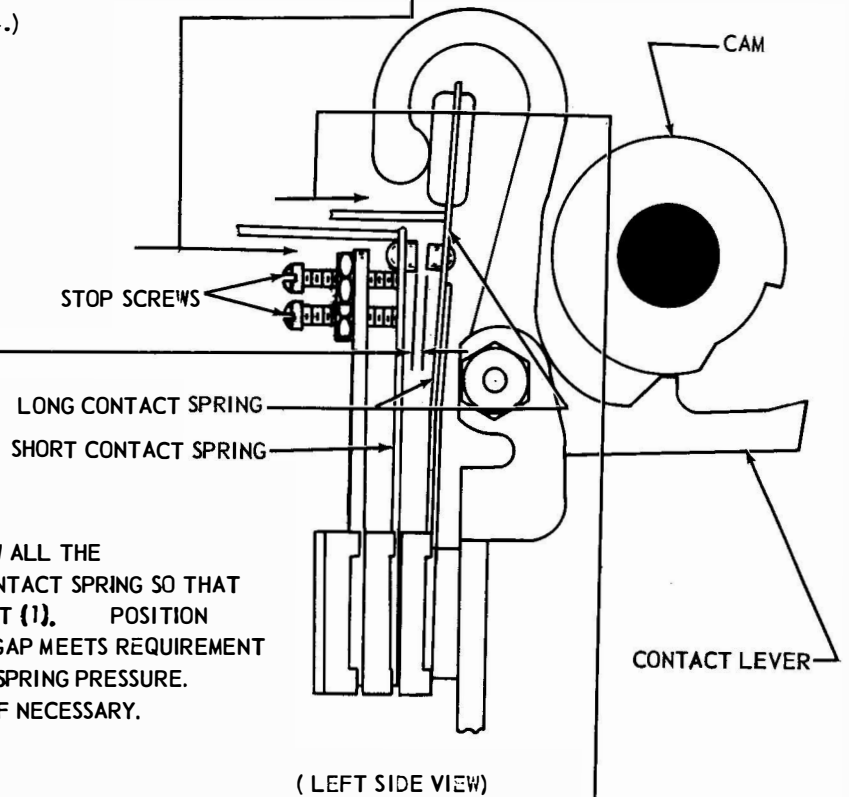
LONG CONTACT SPRING (PRELIMINARY)

REQUIREMENT

CONTACT LEVER ON HIGH PART OF CAM.

7 OZS.

TO START SPRING MOVING.

TO ADJUST

SEE FIGURE 3-16

FIGURE 3-15 CONTACT MECHANISM

3-3 MULTIPLE WIRE DISTRIBUTOR UNIT ADJUSTMENTS (EARLY DESIGN) - CONTINUED

NOTE

(1) THESE ADJUSTMENTS SHOULD BE MADE FOR EACH OF THE SEVEN CONTACTS ON THE DISTRIBUTOR.

(2) FOR 72003 CONTACT SPRING BENDER, SEE TELETYPE BULLETIN 1124B.

LONG CONTACT SPRING (PRELIMINARY)
REQUIREMENT

SEE FIGURE 3-15

TO ADJUST

BACK OFF STOP SCREW ALL THE WAY. ROTATE CAM SLEEVE UNTIL ASSOCIATED CONTACT LEVER IS ON LOW PART OF CAM. FACE REAR OF UNIT.

(1) TO INCREASE SPRING PRESSURE:

FROM RIGHT SIDE, INSERT 72003 CONTACT SPRING BENDER WITH PROJECTION DOWNWARD BETWEEN CONTACT BRACKET AND SPRING STIFFENER. ROTATE SPRING BENDER CLOCKWISE TO BEND SPRING AND SPRING STIFFENER.

(2) TO DECREASE SPRING PRESSURE:

FROM RIGHT SIDE, INSERT 72003 SPRING BENDER WITH PROJECTION UPWARD BETWEEN LONG AND SHORT CONTACT SPRINGS. ROTATE SPRING BENDER CLOCKWISE TO BEND SPRING AND SPRING STIFFENER.

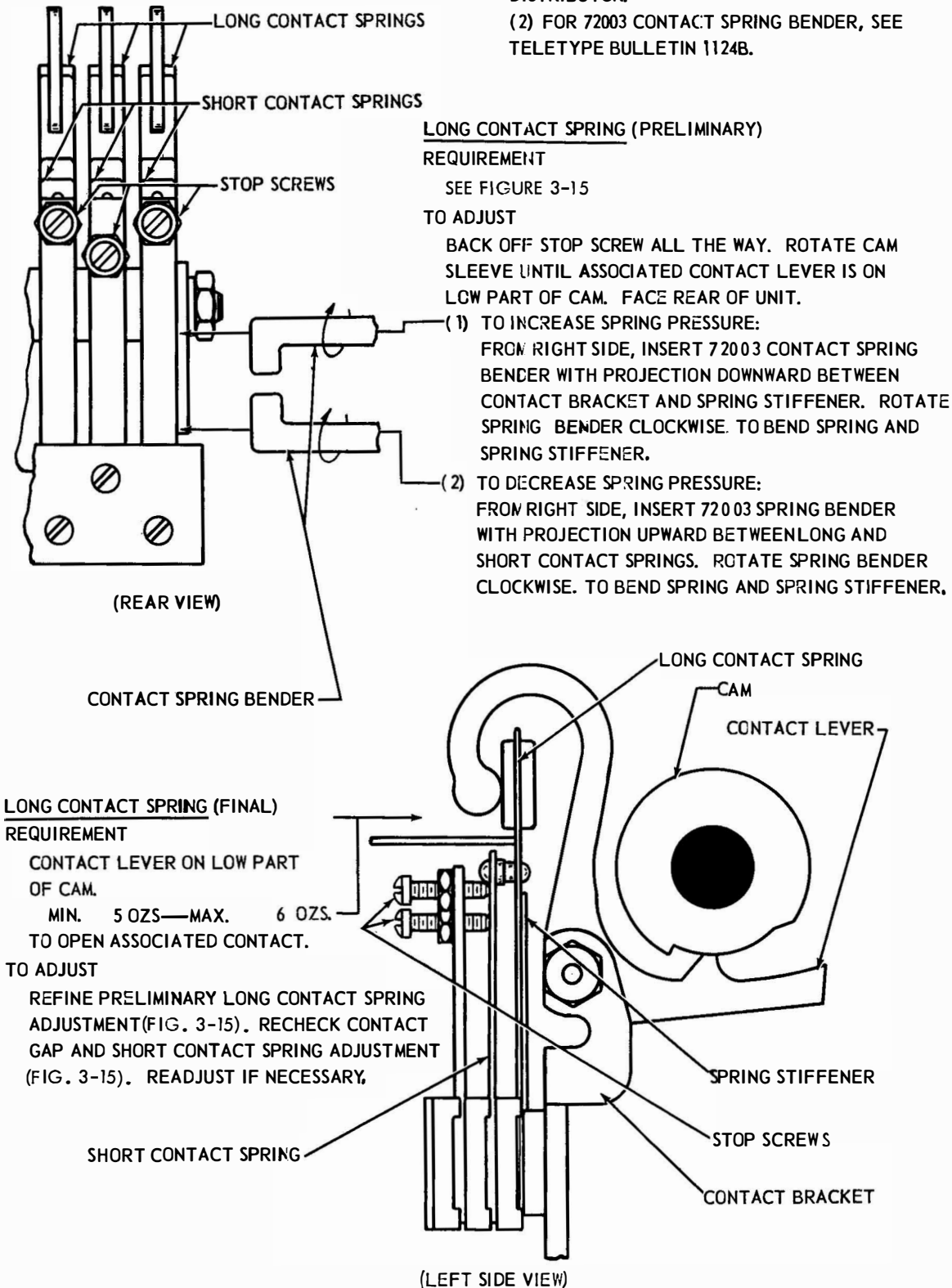

FIGURE 3-16 CONTACT MECHANISM

3-4 BASE AND MOTOR UNIT

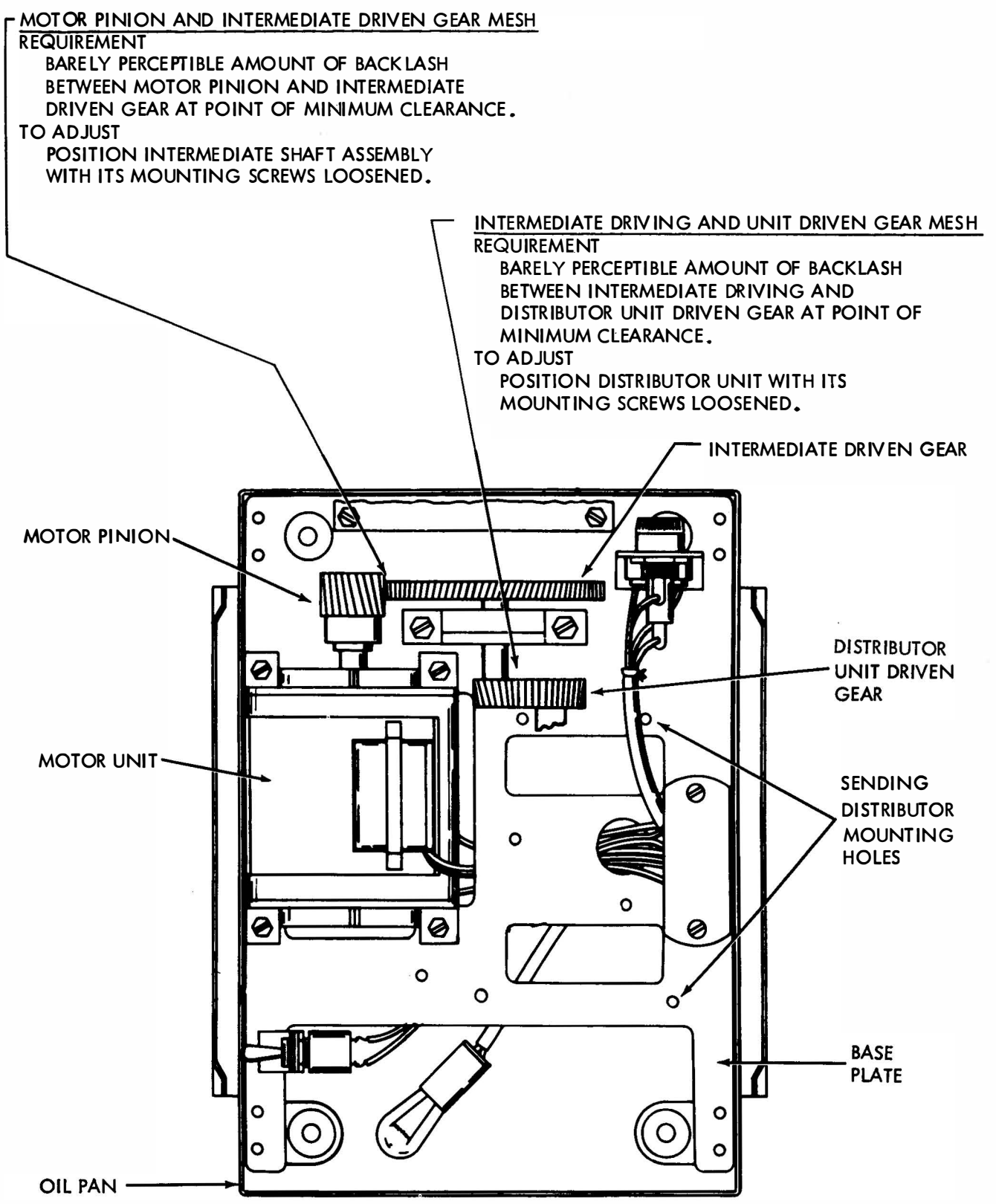
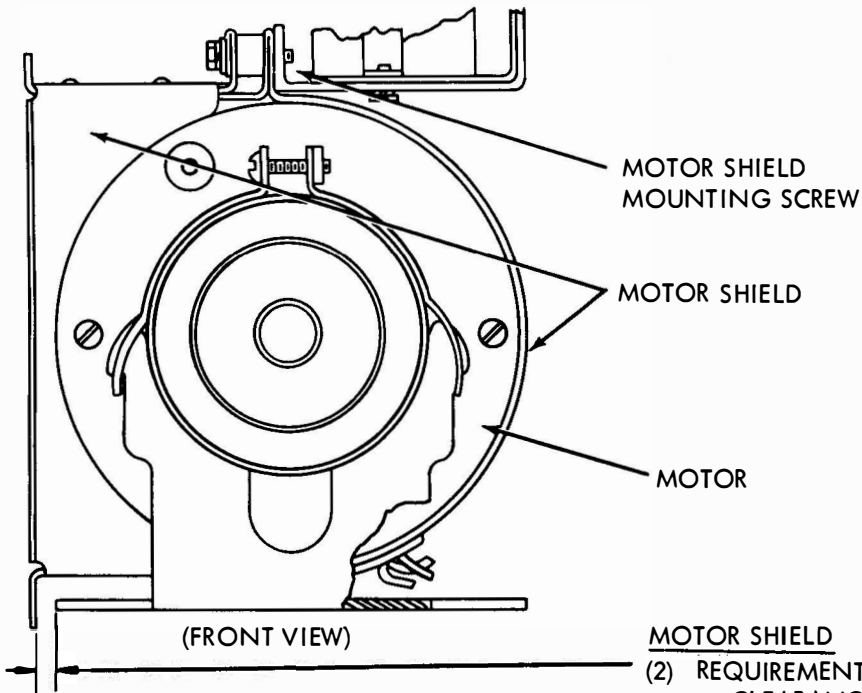

FIGURE 3-17

3-4 BASE AND MOTOR UNIT (CONTINUED)



MOTOR SHIELD

(2) REQUIREMENT

CLEARANCE BETWEEN MOTOR SHIELD AND
MOTOR MOUNTING BRACKET:
MIN. 0.062 INCH

TO ADJUST
POSITION MOTOR SHIELD WITH ITS MOUNTING
SCREWS LOOSENED

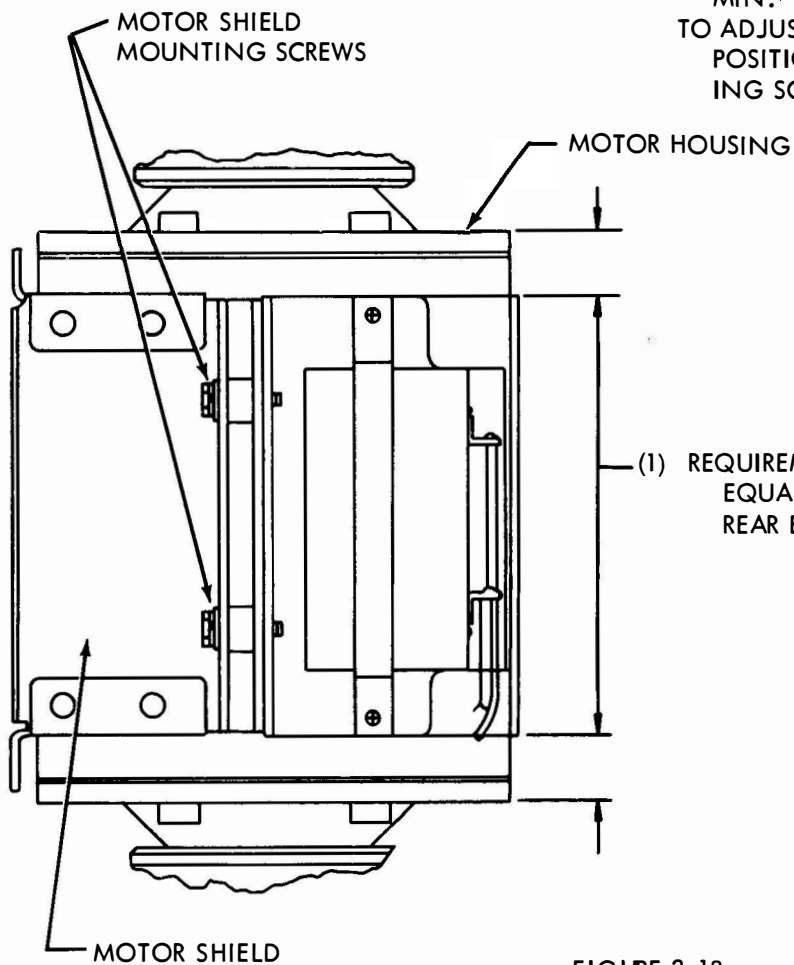

FIGURE 3-18

SECTION 4
LUBRICATION

4-1. GENERAL

a. Lubricate the Multiple Wire Distributor as directed in this section. The figures indicate points to be lubricated, and the kind and quantity of lubricant to be used. Lubricate the unit just prior to placing it in service. Re-lubricate after a few weeks in service to make certain that all points have received attention. Thereafter, follow the scheduled outlined below:

<u>Operating Speed</u>	<u>Lubrication Interval</u>
60 WPM	3000 hours or 1 year *
75 WPM	2400 hours or 9 months *
100 WPM	1500 hours or 6 months *

* Whichever occurs first.

On early design units, the lubrication interval is every 500 hours for operation at any speed.

NOTE

Apply two drops of KS7470 oil to motor bearings every four months. If the motor is disassembled at any time, repack the bearings with KS7471 grease.

b. Use Teletype KS7470 oil at all locations where the use of oil is indicated. Use KS7471 grease on all surfaces where grease is indicated.

c. All spring wicks and felt oilers should be saturated. The friction surfaces of all moving parts should be thoroughly lubricated. Over-lubrication, however, will permit oil or grease to drip or be thrown on other parts, and should be avoided. Special care must be taken to prevent any oil or grease from getting between the armature and its magnet pole faces or between electrical contacts.

d. The illustration symbols indicate the following lubrication directions:

- O Apply 1 drop of oil.
- O2 Apply 2 drops of oil.
- O3 Apply 3 drops of oil.
- G Apply thin film of grease.
- SAT Saturate (Felt oilers, washers, wicks) with oil.
- FILL Fill (oil cup) with oil.

e. All of the drawings in this section were drawn with respect to a five level unit. Eight level units differ only in the number of cams, contacts, and associated parts.

4-2 MULTIPLE WIRE DISTRIBUTOR UNIT LUBRICATION - LATE DESIGN

a. CLUTCH TRIP - MAGNET MECHANISM

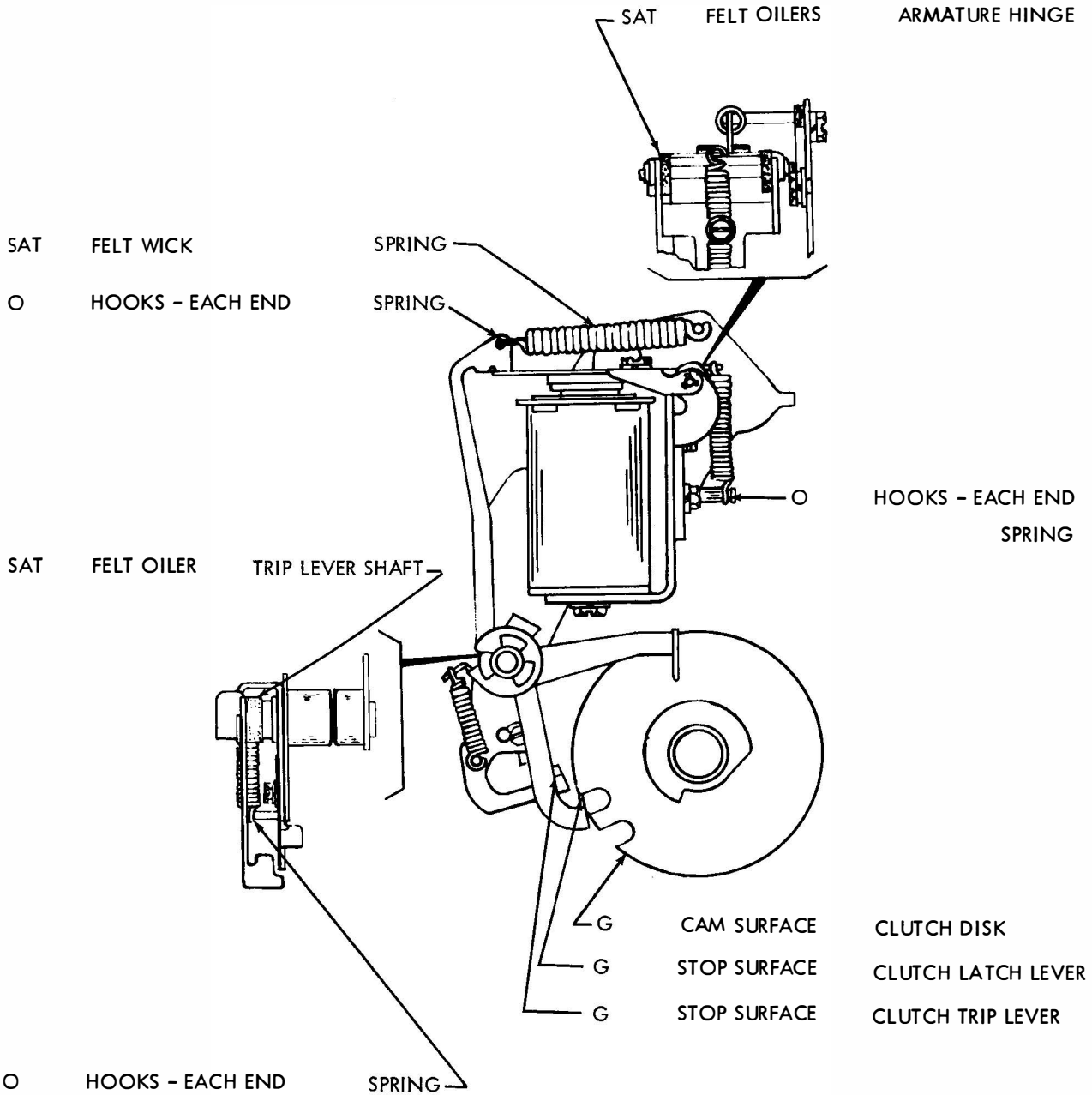

4-2 MULTIPLE WIRE DISTRIBUTOR UNIT LUBRICATION - LATE DESIGN (CONTINUED)

b. CONTACT LEVER AND CAM SLEEVE ASSEMBLIES

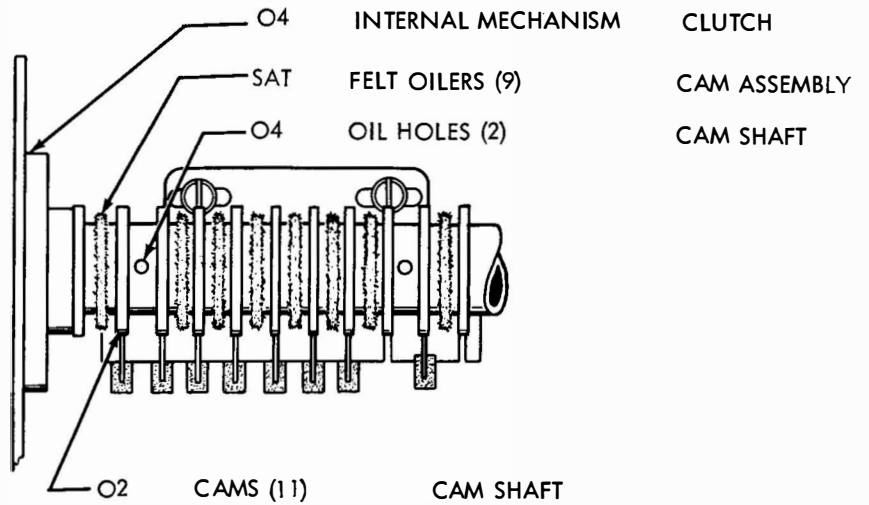
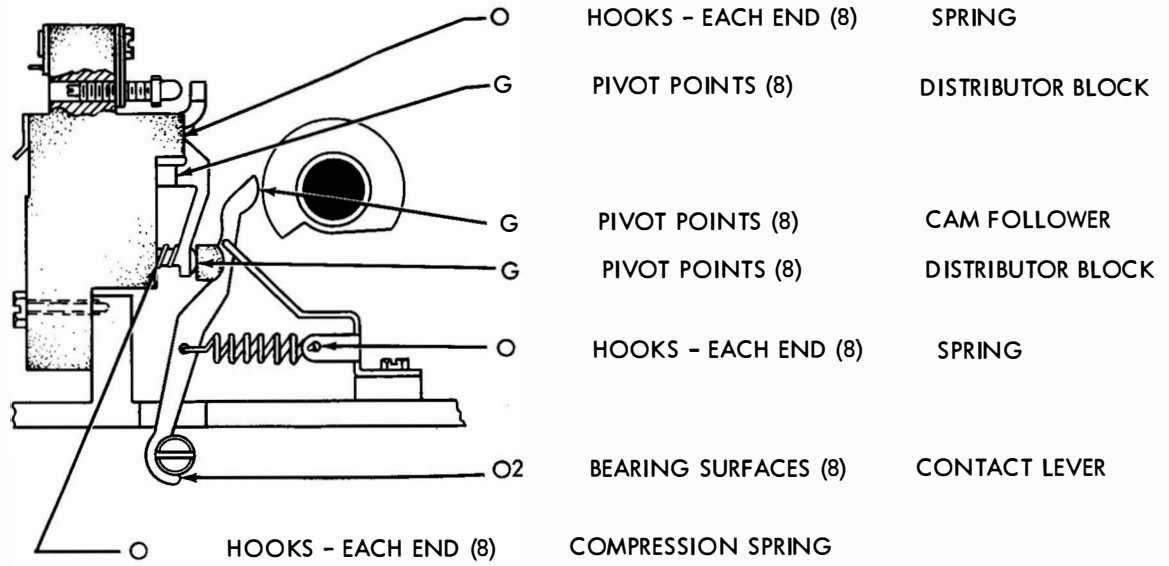

4-3 MULTIPLE WIRE DISTRIBUTOR UNIT LUBRICATION - EARLY DESIGN

a. MULTIPLE WIRE DISTRIBUTOR

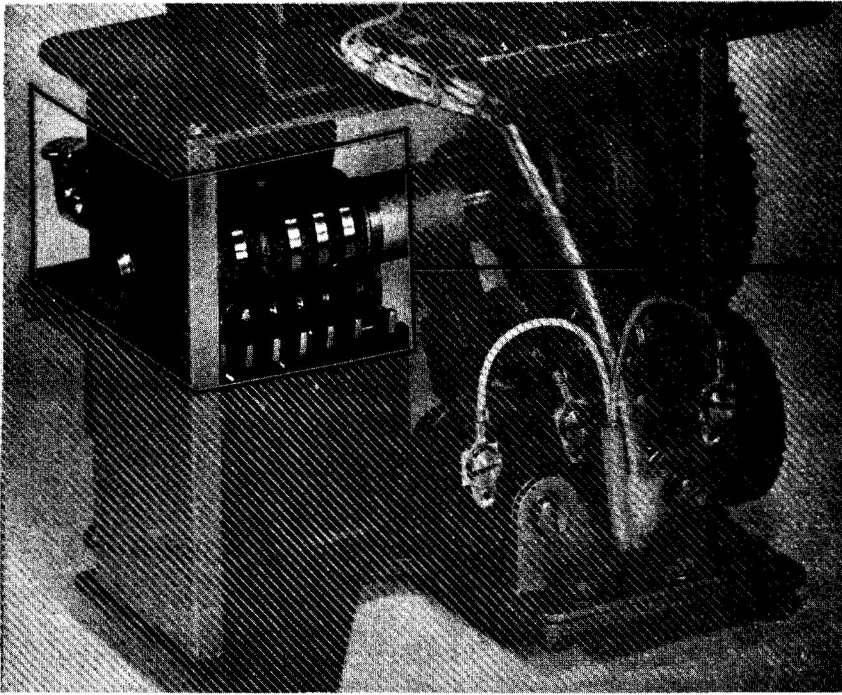

(FRONT VIEW)

4-3.b.

b. CONTACT LEVER AND CAM SLEEVE ASSEMBLIES

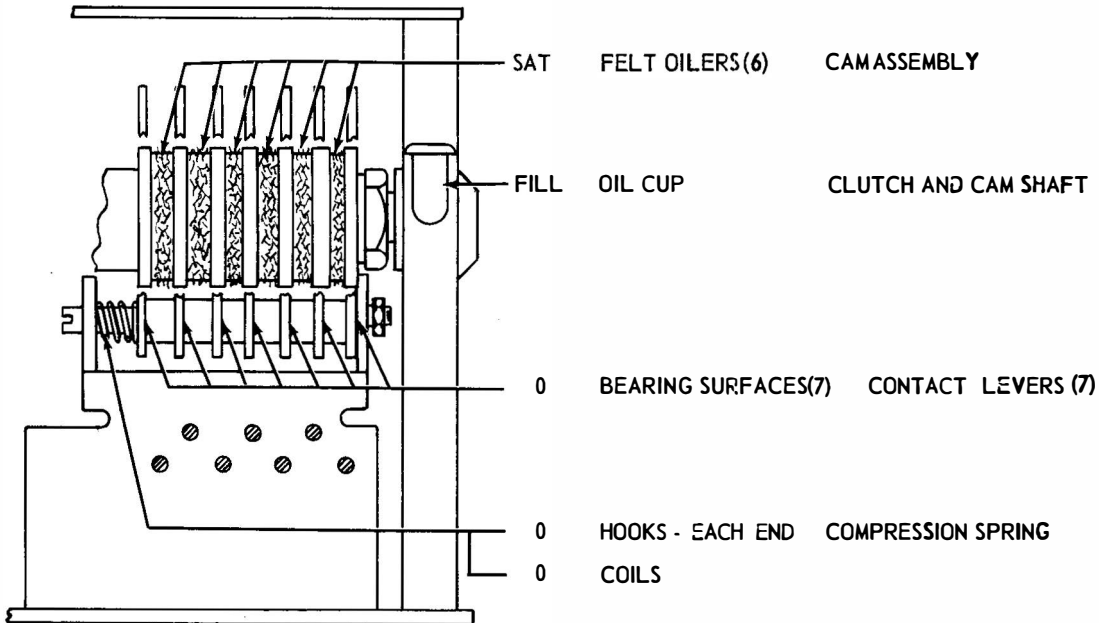

(REAR VIEW)

4-3 MULTIPLE WIRE DISTRIBUTOR UNIT LUBRICATION - EARLY DESIGN (CONTINUED)

c. MULTIPLE WIRE DISTRIBUTOR

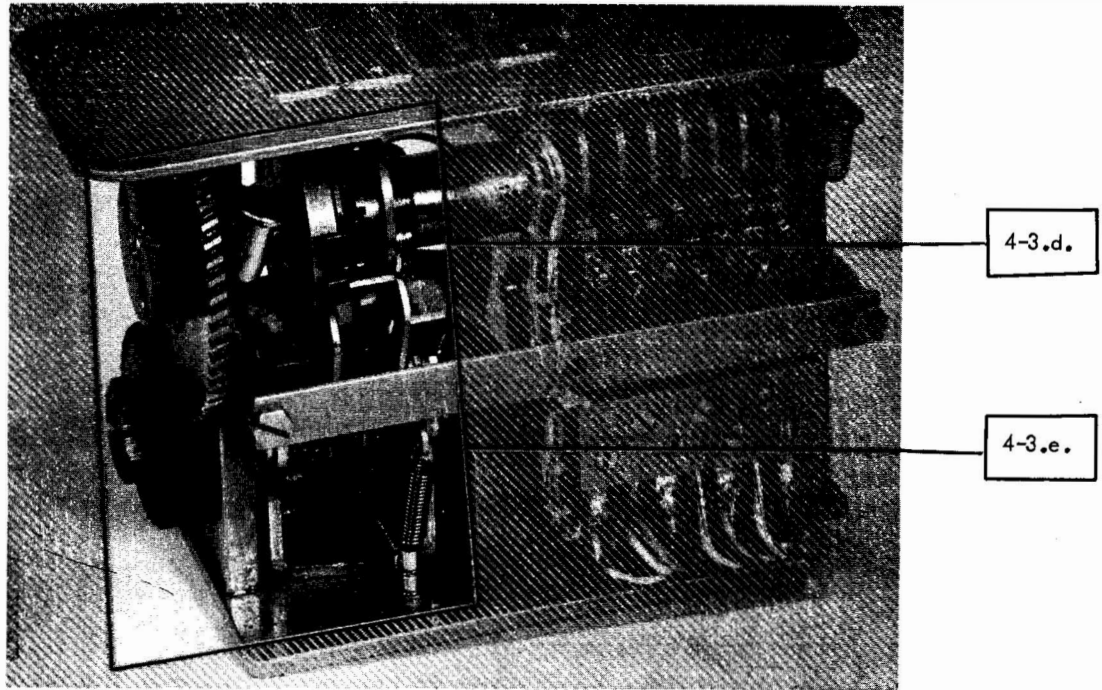

(REAR VIEW)

d. CLUTCH AND GEAR ASSEMBLIES

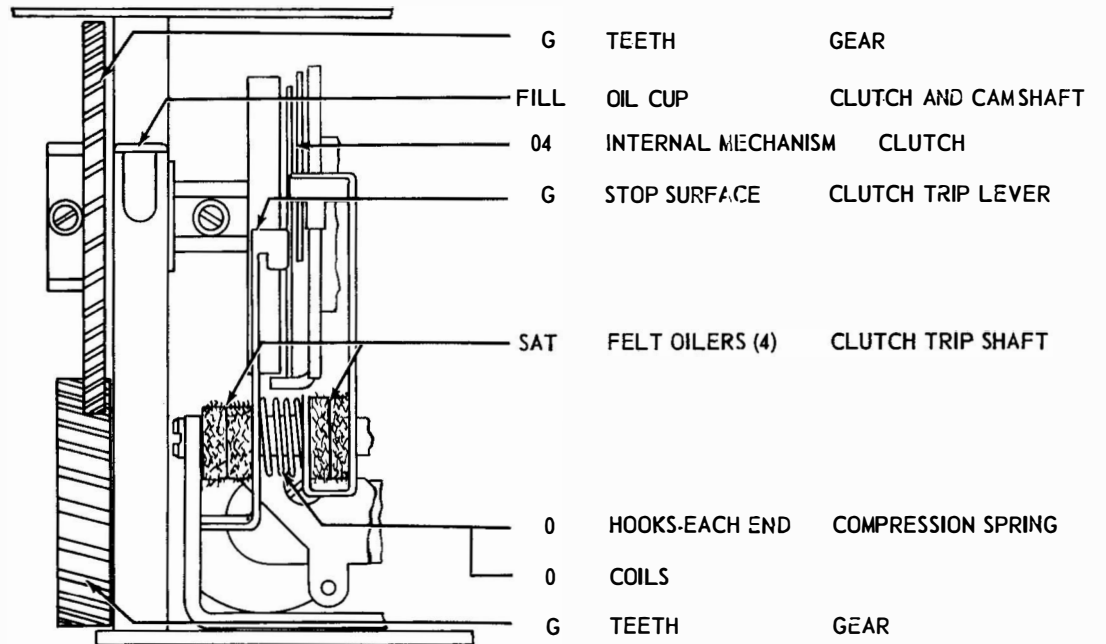

(REAR VIEW)

4-3 MULTIPLE WIRE DISTRIBUTOR LUBRICATION - EARLY DESIGN (CONTINUED)

e. CLUTCH TRIP-MAGNET MECHANISM

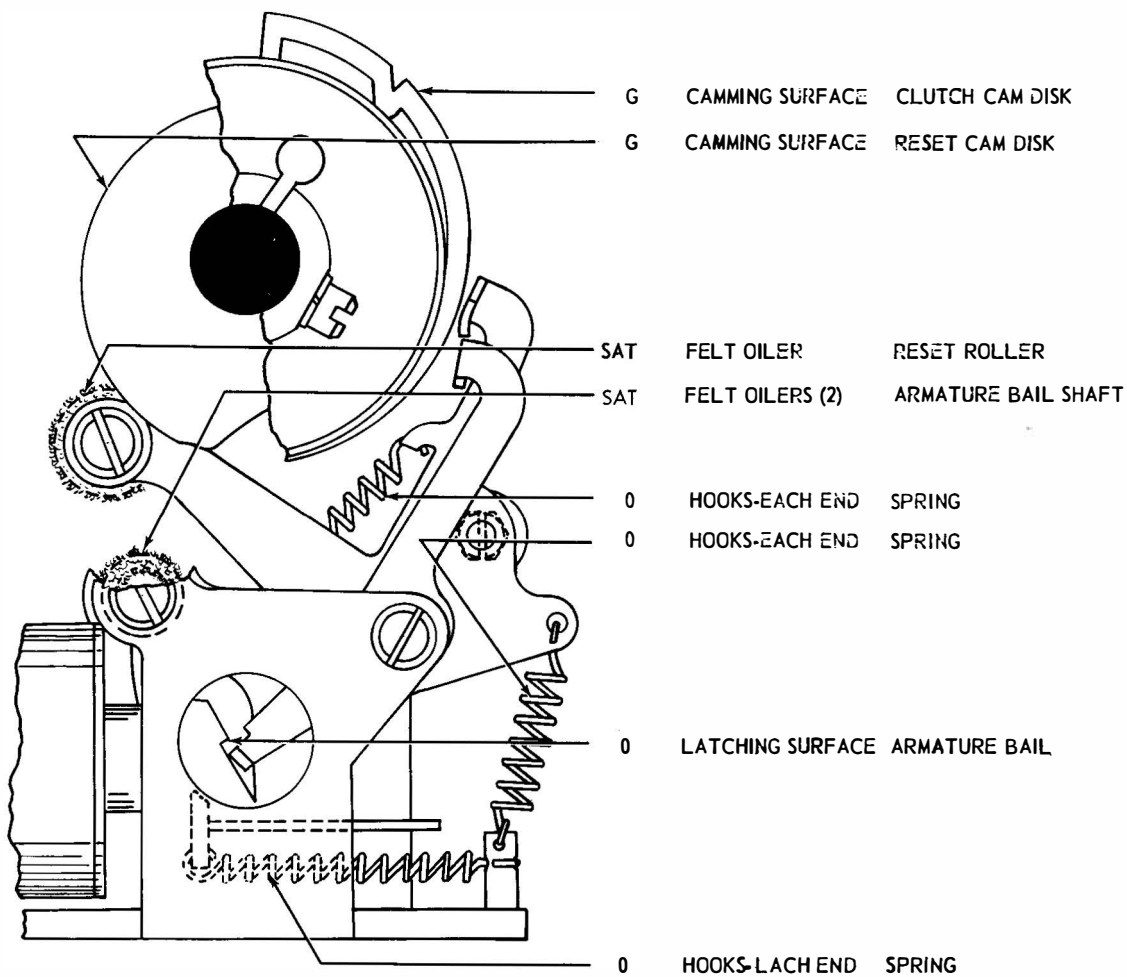

(RIGHT SIDE VIEW)

4-4 BASE AND MOTOR UNIT LUBRICATION

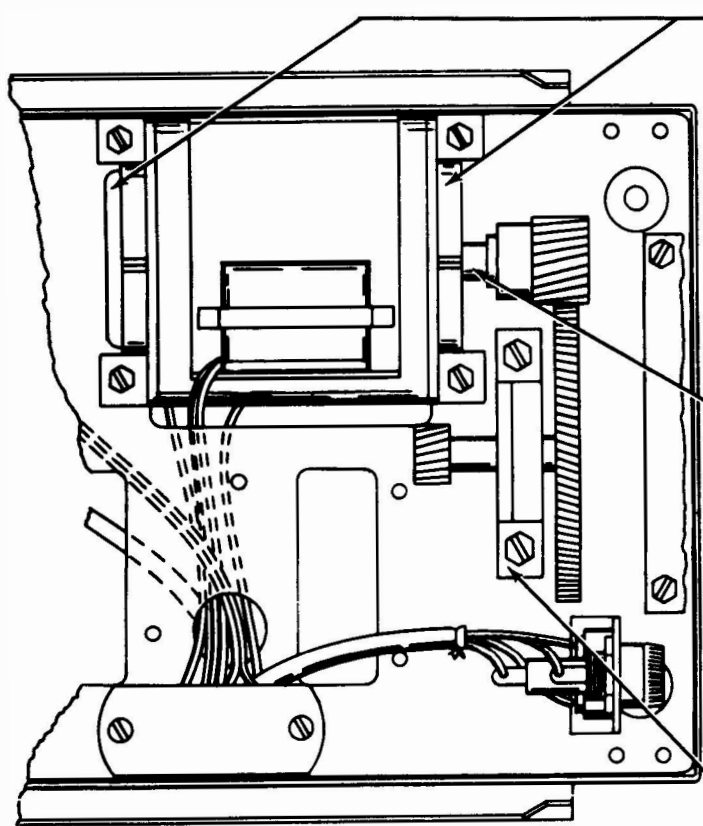
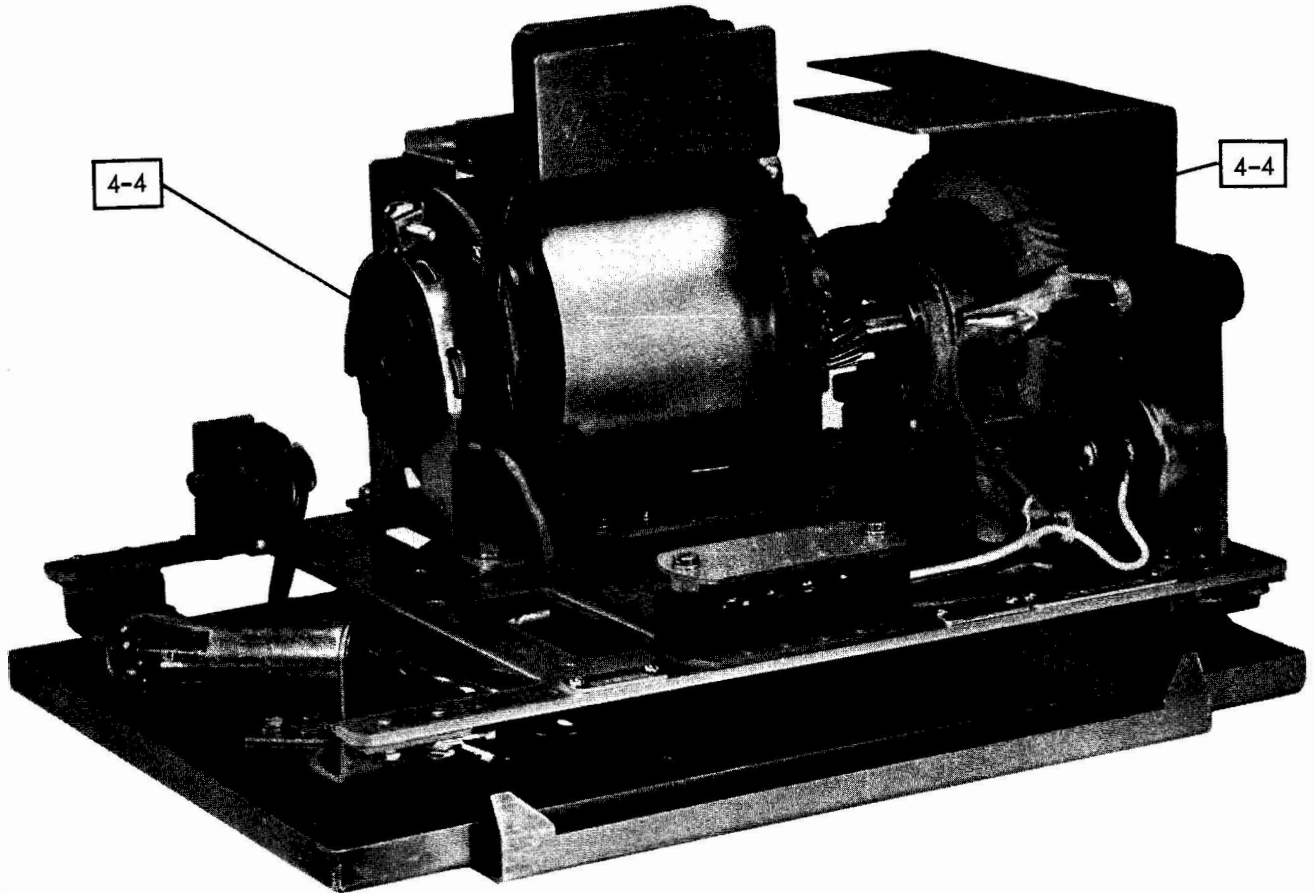

O6 OILERS MOTOR BEARINGS (EACH END OF SHAFT)

NOTE
OIL MOTOR EVERY 750 HOURS OF CONTINUOUS OPERATION OR EVERY 3 MONTHS, WHICHEVER OCCURS FIRST.

G SHAFT MOTOR UNIT

NOTE
IF MOTOR IS DISASSEMBLED, REPACK BEARINGS WITH KS7471 GREASE.

G GEARS MOTOR PINION, INTERMEDIATE, AND UNIT GEARS

