

COMPASS
73
NEW YORK 13, N. Y.

BULLETIN 225B

TELETYPE

PRINTING TELEGRAPH SYSTEMS

BULLETIN 225B

GENERAL DESCRIPTION
THEORY OF OPERATION
MODEL 28 PRINTER SET
(STUNT BOX C.A.A)



COPYRIGHT 1955 BY TELETYPE CORPORATION IN UNITED STATES
COPYRIGHT IN ALL COUNTRIES PARTICIPATING IN INTERNATIONAL
CONVENTION AND PAN AMERICAN CONVENTIONS. ALL RIGHTS
RESERVED INCLUDING RIGHTS OF TRANSLATION INTO ALL LANGUAGES.

Printed in U.S.A.

LIST OF EFFECTIVE PAGES

JANUARY 1955

| PAGE NUMBERS | CHANGE IN EFFECT |
|----------------|------------------|
| TITLE PAGE | ORIGINAL |
| EFFECTIVE PAGE | ORIGINAL |
| B and C | ORIGINAL |
| 1-1 to 1-2 | ORIGINAL |
| 2-1 to 2-19 | ORIGINAL |
| 3-0 to 3-48 | ORIGINAL |

THIS PAGE LISTS THE EFFECTIVE PAGES IN THE BULLETIN
AND MUST BE REPLACED WHEN CHANGES ARE BEING MADE.

TABLE OF CONTENTS

| Paragraph | Page |
|---|------------------|
| SECTION 1 GENERAL DESCRIPTION | |
| 1. General | 1-1 |
| 2. Station Selection | 1-1 |
| 3. Description of Components | 1-1 |
| a. Base | 1-1 |
| b. Typing Unit | 1-2 |
| c. Motor Unit | 1-2 |
| d. Electrical Service Unit | 1-2 |
| e. Cabinet | 1-2 |
| 4. Power Requirements | 1-2 |
| SECTION 2 THEORY OF OPERATION | |
| 1. General | 2-1 |
| 2. Signaling Code | 2-1 |
| 3. Base | 2-2 |
| a. General | 2-2 |
| b. Intermediate Gear Assembly | 2-2 |
| c. Local Carriage Return Mechanism | 2-2 |
| d. Local Line Feed Mechanism | 2-2 |
| e. Margin Indicator Mechanism | 2-2 |
| f. Local Remote Switch | 2-2 |
| 4. Typing Unit | 2-2 |
| a. General | 2-2 |
| b. Main Shaft | 2-3 |
| c. Selecting Mechanism | 2-3 |
| d. Orientation | 2-4 |
| e. Printing Mechanism | 2-5 |
| (1) Code Bar Mechanism | 2-5 |
| (a) General | 2-5 |
| (b) Code Bar Positioning | 2-5 |
| (c) Arrangement of Code Bars | 2-5 |
| (2) Type Box and Type Box Carriage | 2-6 |
| (a) General | 2-6 |
| (b) Type Box Positioning | 2-6 |
| (3) Printing Hammer and Printing Carriage | 2-9 |
| (a) General | 2-9 |
| (b) Printing Carriage Positioning | 2-9 |
| (c) Printing | 2-9 |
| f. Spacing | 2-9 |
| (1) General | 2-9 |
| (2) Spacing Suppression | 2-10 |
| g. Margin Indicator | 2-10 |
| h. Ribbon Mechanism | 2-10 |
| (1) Positioning | 2-10 |
| (2) Feeding | 2-10 |
| SECTION 3 FIGURES | |
| | 3-D; 3-48 |

| Paragraph | Page |
|---|------|
| i. Functions. | 2-11 |
| (1) General | 2-11 |
| (2) Letters and Figures Shift Function. | 2-12 |
| (3) Carriage Return Function. | 2-12 |
| (4) Line Feed Function. | 2-13 |
| (5) Automatic Carriage Return - Line Feed Function. | 2-14 |
| (6) Signal Bell Function. | 2-15 |
| j. Sequential Selection Mechanism | 2-15 |
| (1) General | 2-15 |
| (2) Station Selection | 2-15 |
| (3) Remote Control Switching. | 2-17 |
| 5. Motor Unit | 2-17 |
| a. General. | 2-17 |
| b. Rating | 2-17 |
| c. Components | 2-17 |
| d. Starting | 2-17 |
| e. Overload Reset | 2-18 |
| 6. Electrical Service Unit. | 2-18 |
| a. General. | 2-18 |
| b. Line Relay | 2-18 |
| c. Line Shunt Relay | 2-18 |
| d. Rectifier. | 2-18 |
| e. Cables | 2-18 |
| f. Fusing | 2-18 |
| g. Signal Current | 2-18 |
| 7. Cabinet. | 2-18 |
| a. General. | 2-18 |
| b. Signal Bell. | 2-18 |
| c. Power Switch | 2-18 |
| d. Copy Light | 2-19 |
| e. Margin Indicator Lamp. | 2-19 |

SECTION 1

GENERAL DESCRIPTION

1. GENERAL.

a. The MODEL 28 RECEIVING ONLY PRINTER SET described herein is intended for use in a country wide communications system consisting of interconnected local area networks. With their motors running continuously, the printers in any one area network may be individually or collectively selected by the sending station to receive a message while excluding the unselected stations. Printers in other areas may be similarly selected by routing the receiving station call through relay stations where facilities are available for entering the networks in adjacent areas.

b. Certain specified stations, not located in the same general area, are interconnected by an express network which extends across the country and by-passes the local area networks. The express network functions in much the same manner as does one of the local area networks except the "area" now refers to the entire country.

c. The printer typing unit can be shifted to a position where printing is suppressed and all normal functions are deactivated with the exception of the carriage return function. This position is known as the STUNT CASE. When network operation utilizing station selection is desired, the printer is shifted to the STUNT CASE until selected to receive a message.

2. STATION SELECTION.

a. A station or area call is composed of a CONDITION CODE sequence, consisting of CR-CR-LTRS, followed by the station or area call letter sequence, consisting of a three character sequence. All printers respond to the CONDITION CODE which momentarily opens a "gate". Only the called station or stations will respond to the subsequent sequence of letters immediately following the CONDITION CODE.

b. Upon receipt of a station or area call, the printer typing unit will shift

out of the STUNT CASE and commence printing the transmitted message.

c. Upon receipt of the END OF MESSAGE sequence, consisting of FIGS-CR-LTRS, the printer typing unit shifts to the STUNT CASE.

d. The LOCAL-REMOTE switch, located on the keylever cover, shifts the typing unit out of the STUNT CASE when in the LOCAL position and transfers control of the STUNT CASE shift to associated station equipment when in the REMOTE position.

(1) When the switch is placed in the LOCAL position, the typing unit is shifted out of the STUNT CASE, even though the END OF MESSAGE sequence is received, and commence printing any message transmitted over the signal line.

(2) If the connection to associated station equipment is not completed when the switch is placed in the REMOTE position, the typing unit will shift directly to the STUNT CASE unless the printer set has been previously selected to receive a message. Upon completion of the message and receipt of the END OF MESSAGE sequence, the typing unit will shift to the STUNT CASE. However, if the connection to associated station equipment is energized when the switch is placed in the REMOTE position, the typing unit will remain shifted out of the STUNT CASE.

e. Associated station equipment, such as Reperforators, Transmitter Distributors, etc. can be remotely controlled by means of electrical switches mounted on the stunt box within the typing unit. These switches are actuated upon receipt of the proper code signal sequence. All switches are of the single-pole single-throw type.

3. DESCRIPTION OF COMPONENTS.

a. BASE. (Figure 1-2.) - The base serves as a chassis for mounting the motor unit, typing unit, and intermediate gears and includes linkages for local operation of the carriage return and line feed func-

b. TYPING UNIT. (Figure 1-3.)

(1) The typing unit incorporates the necessary electrical and mechanical components for translating the code signals into mechanical motions in order to record the message and perform the usual functions pertinent to printing.

(a) Type pallets are arranged in a compact, lightweight type box which may be readily detached for cleaning or replacement by another type box. In operation, the type box keeps step with a printing carriage and presents the proper type pallets to the printing hammer to receive its strokes as the printing carriage advances along the line. The type box and printing carriages are so designed that carriage motion is unaffected by non-level positioning of the typing unit. The light weight and consequently, reduced mass of these components permit printing at speeds up to 100 words per minute.

(b) A high speed selector electromagnet operates with low coil current and requires few adjustments. The range setting for optimum response to line signals is quickly obtained by means of direct readings on a self-locking knob.

(c) The all steel internal expansion clutches on the main shaft are completely disengaged at the termination of each operating cycle and thus reduce the motor load to the minimum when no signals are being received. Clutch engagement is quick, positive, and uniform, driving the load without slippage. They require no lubrication.

(d) The stunt box (Figure 1-4), located in the rear of the typing unit, enables use of the printer for the performance of non-typing operations, such as station selection or remote control of auxiliary apparatus, in addition to the conventional functions pertinent to printing. There are 42 slots, each of which will accommodate a function bar and its associated mechanism. Nine of these slots are employed to control such normal functions as carriage return, line feed, letters and figures shift, signal bell, etc. The remaining 33 slots are available for special non-typing applications. The coded ends of the function bars face the notches in the adjacent code bars.

c. MOTOR UNIT. (Figure 1-5.)

(1) A two pole, single phase, capacitor start synchronous motor is a part of the motor unit located at the rear of the base. A relay, capacitor, and a manual reset thermal cutout switch are contained in a compartment mounted beneath the motor. The relay is used to start the motor. The motor is mounted and held in a cradle by straps at each end. Resilient mounts on the motor end bell hubs reduce transmission of vibration to the base.

(2) The motor is the source of motive power for those mechanisms deriving motion from the main shaft.

d. ELECTRICAL SERVICE UNIT. (Figure 1-6.) - The electrical service unit is mounted in the cabinet directly behind the Typing Unit and Base. Essentially, it is a chassis for such accessories as a line relay, line shunt relay, rectifier, fuses, etc. which are all independently installed as assemblies. Interconnections are simple and adaptable to permit installation of a standard printer under a variety of circuit terminations.

e. CABINET. (Figures 1-7 and 1-8.)

(1) The cabinet has been designed to provide easy access to the printer for maintenance and to suppress the noise of operation. An internal lamp illuminates the copy. The window above the copy is tilted to minimize glare. All mechanical controls are accessible from the front of the cabinet. The hood swings up and remains open in any position. The Base is mounted on a cradle which pivots forward to permit access to the sides and rear of the Typing Unit and to the Motor Unit.

(2) The cabinet dimensions are approximately: Height 40 $\frac{1}{2}$ " , Width 20 $\frac{1}{2}$ " , Depth 18 $\frac{1}{2}$ " . The total weight of the complete unit consisting of the Base, Typing Unit, Electrical Service Unit, Cabinet, etc. is approximately 120 pounds.

4. POWER REQUIREMENTS.

A 115 volts, single phase A.C., 60 cycle supply is required for units using a synchronous motor unit.

SECTION II

THEORY OF OPERATION

1. GENERAL.

a. In this section, a detailed description of the electrical and mechanical principles involved in the operation of the Model 28 RECEIVING-ONLY PRINTER SET described in the preceding section is presented. The distinguishing feature of this printer is its stunt box which incorporates a sequential selection mechanism in addition to the direct selection mechanism used to initiate performance of conventional functions. The printer can be adapted to operate at any one of the following maximum speeds; 368, 460, or 600 operations per minute (opm) which correspond approximately to 60, 75, or 100 words per minute (wpm).

b. The functional block diagrams, Figures 2-1 and 2-2, indicate the manner in which the various components interact to produce the printed copy upon receipt of line signals.

(1) Line signals enter the printer set (Figure 2-1) through the line shunt relay and are applied to the line relay which repeats the line signals in the selector magnet circuit. The selector mechanism positions the code bars. If the printer is not in the STUNT CASE, positioning the code bars will cause direct selection of a function or auxiliary switch, or cause printing to occur. If the printer is in the STUNT CASE, a predetermined sequence of signals will effect sequential selection of a function or auxiliary switch, or position the suppression code bar which repositions the type box clutch suppression mechanism to allow functioning of the printing mechanism. The type box clutch suppression mechanism may also be solenoid-operated through the LOCAL-REMOTE switch which has two electrical inputs. Thus the type box clutch suppression mechanism is controlled either locally by the LOCAL-REMOTE switch or remotely by the sending station.

(2) Figure 2-2 shows the distribution of mechanical and electrical power within the printer set. A.C. power entering the set is connected directly to an

unfused convenience outlet on the Electrical Service Unit. The line, fused on one side, then enters the power switch. The lamp switch is wired so that it can turn the copy light on whether the power switch is ON or OFF. The power to operate the signal bell passes through the signal bell contacts located on the stunt box. From the power switch, power is distributed to the primary of the rectifier, the motor unit, and to the line shunt relay. The rectifier supplies d.c. to the selector magnet through the line relay and to the line relay bias winding if necessary. The mechanical output of the motor is transferred through the intermediate gear assembly to the main shaft which imparts motion to the selector mechanism, functions mechanism, code bar mechanism, and the printing mechanism.

2. SIGNALING CODE.

a. The signaling code is the START-STOP five element code consisting of current and no-current intervals. Intervals during which the selector magnet is energized are known as marking impulses and those during which the selector magnet is not energized are known as spacing impulses. Each group of five selecting elements is preceded by a START (no-current) interval and followed by a STOP (current) interval. The START and STOP intervals are necessary to maintain synchronism between the transmitting and receiving apparatus.

b. If the period of one selecting interval is defined as being equivalent to one unit, each character, independent of the maximum operating speed, is 7.42 units in length. The START and five selecting impulses are each one unit in length while the STOP impulse is 1.42 units in length (Figure 2-3).

c. The frequency of the line signal is expressed in terms of maximum dot cycles per second. One cycle is defined as one current impulse followed by one no-current impulse. The following frequencies are characteristic of the indicated operating speeds.

| Operating Speed | Frequency |
|-----------------|-----------|
| 60 WPM | 22.8 CPS |
| 75 WPM | 28.5 CPS |
| 100 WPM | 37.1 CPS |

3. BASE, RECEIVING ONLY.

a. GENERAL. - The base is fabricated from sheet metal. It has facilities for mounting a Typing Unit and Motor Unit. The following assembly and mechanisms are included in the Base.

b. INTERMEDIATE GEAR ASSEMBLY. - An intermediate gear assembly, located on the rear center of the Base, supports two helical gears. These gears transfer power from the motor to the Typing Unit. When the Motor and Typing Units are in place, the helical driving gear on the motor shaft meshes with the intermediate helical driven gear and drives the intermediate shaft. The gear ratio between the motor driving gear and the intermediate driven gear determines the maximum operating speed of the Typing Unit. These gears are readily replaceable with gears which will furnish other standard operating speeds.

c. LOCAL CARRIAGE RETURN MECHANISM. - Operation of the local carriage return keylever causes its function lever to raise the forward end of a local carriage return bail (Figure 2-4). The bail rotates about its pivot point until the upper end engages the carriage return lever on the Typing Unit. Thus, the carriage return mechanism on the Typing Unit is operated without disturbing other Typing Units on the same line circuit. The carriage return mechanism is fully described in paragraph 4.i. (3) of this section.

d. LOCAL LINE FEED MECHANISM. - Operation of the local line feed keylever causes an associated function lever to raise the forward end of a local line feed bail (Figure 2-5). The bail rotates about its pivot point and the upper end pushes the trip link until the link engages the line feed clutch trip lever on the Typing Unit. Thus, the line feed mechanism on the Typing Unit is operated without disturbing other printers on the same line circuit. The line feed mechanism is fully described in paragraph 4.i. (4) of this section.

e. MARGIN INDICATOR MECHANISM. - A margin indicator cam disk on the Typing Unit spring drum (Figure 2-6) rotates with the drum as printing or spacing occurs. As the end of the line is approached, the cam surface of the disk makes contact with the margin indicator contact lever and rotates it clockwise about its pivot. When the contact lever leaves the switch plunger, the margin indicator switch operates and closes the circuit to the margin indicator lamp on the cabinet. When the carriage returns to the beginning of a line, the cam disk is returned to its starting position and the margin indicator switch opens.

f. LOCAL-REMOTE SWITCH.

(1) When the LOCAL-REMOTE switch is placed in the Local position, a solenoid mounted on the left side frame of the Typing Unit (Figure 7) is energized by 115 volts A.C. from the motor terminal block. In the REMOTE position, the solenoid is conditionally energized by 115 volts A.C. derived from associated station apparatus. Upon being energized, the solenoid attracts the moveable iron core causing a blocking bail lever to pivot and bear against the blocking bail arm. The blocking bail pivots and removes the blocking bail extension from the path of a suppression arm attached to the type box clutch trip arm. As the clutch trip lever shaft rotates, the type box clutch trip arm engages the clutch trip lever and releases the type box clutch.

(2) When the switch is in the REMOTE position and no external voltage is applied to energize the solenoid, the blocking bail extension blocks the suppression arm and type box clutch trip arm, and consequently prevents rotation of the clutch trip lever shaft. The printing mechanism is then unable to function.

4. TYPING UNIT.

a. GENERAL. - The primary function of the Typing Unit is to print the incoming message as it is received from the signal line. Every other unit, component, and assembly, is intended to supplement the Typing Unit in the performance of this function. Secondary functions, such as station selection or remote control of auxiliary or associated station apparatus

are accomplished through extensive utilization of the stunt box. The following mechanisms constitute the Typing Unit.

b. MAIN SHAFT (Figure 2-8).

(1) The main shaft is situated in the lower rear portion of the Typing Unit. It extends across the rear of the Typing Unit and is supported by ball bearings mounted in each side frame. When the Typing Unit is placed upon the Base, the main shaft helical driven gear meshes with the intermediate helical driving gear. Through this gear train, mechanical power is transferred from the motor to the Typing Unit.

(2) Six all-steel internal expansion clutches are mounted on the main shaft which rotates continuously when the motor is energized. Two of these, the line feed and spacing clutches, each have three sets of trip lever lugs equally spaced about the clutch periphery. Upon engagement, the spacing clutch will rotate one third of a revolution and the line feed clutch will rotate either one-third or two-thirds of a revolution depending upon whether the single-double line feed lever is set for single or double line feed. The four remaining clutches each have one set of trip lever lugs. Upon engagement, they will rotate one complete revolution.

(3) Each clutch has two shoes, primary and secondary, which bear against the inside surface of a serrated drum at four distinct points. The drum is fastened to the main shaft by a set screw. Consequently, the drum rotates continuously when the motor is running. The associated mechanism is attached to the clutch cam disk which rotates upon engagement. The clutches operate as follows:

(a) Figure 2-9 shows a typical single stop clutch in the disengaged position. Disengagement occurs when lug B on the clutch shoe lever and lug A on the clutch cam disk are brought close together. The clutch shoe lever pivots clockwise about clutch shoe lever ear C which is pivoted in a notch in the upper end of the secondary shoe. Clutch shoe lever ear D is moved to the right. The clutch shoe spring contracts, pulling the two brake

shoes together and away from the serrated drum surface. The drum continues to rotate but the mechanism attached to the clutch cam disk does not.

(b) Figure 2-10 shows the same clutch in the engaged condition. Engagement occurs when lug A on the clutch cam disk and lug B on the clutch shoe lever are released. The clutch shoe lever spring immediately contracts. The clutch shoe lever pivots counterclockwise about clutch shoe lever ear C, overcoming the clutch shoe spring, moving clutch shoe lever ear D to the left, and forcing the primary shoe against the serrated drum surface at E. The counterclockwise rotation of the drum drives the primary shoe downward and so makes further contact with the drum at F. The movement of the primary shoe in the direction of drum rotation is transferred to the secondary shoe at G which causes the secondary shoe to bear against the drum at H. The revolving drum drives the secondary shoe upward to make contact with the drum at I as well as H. A force component is developed at I in a horizontal direction but is transferred to lug J on the clutch cam disk which causes the cam disk to rotate with the drum. The associated mechanism attached to the cam disk then rotates with the drum.

c. SELECTING MECHANISM.

(1) The selecting mechanism consists of the selector electromagnet and armature, a selector cam-clutch, and the associated levers, arms, bails, and slides necessary to convert the electrical code signals into the mechanical motions which determine the characters printed and the functions performed.

(2) The selector magnet performs the actual transition from electrical code signals to equivalent mechanical motions in the Typing Unit. The magnet consists, essentially, of two 132 ohm coils which are wired to a cable connector mounted on the Typing Unit right side frame. A cable from the Electrical Service Unit, when plugged into this connector, connects the selector magnet coils to the selector magnet terminal board in the Electrical Service Unit. The selector magnet coils are wired in series at the factory for 30 milliamperes operation.

(3) The selector cam-clutch comprises, from right to left (Figure 2-8), the clutch, the stop arm bail cam, the fifth, the fourth, and the third selector lever cams, the cams for the spacing and the marking lock levers, the second and the first selector lever cams, the push lever reset bail cam, and the code bar clutch trip cam.

(4) During the time in which a closed line circuit (marking) condition exists, the selector magnet coils are energized and hold the selector armature against the selector magnet pole pieces. In this STOP position, the selector armature blocks the start lever (Figure 2-11). At the start of a signal for any character or function, the START (spacing) interval releases the selector armature which, under the tension of its spring, moves away from the magnet cores and thus unlatches the start lever. The start lever turns clockwise under the tension of its spring to move the stop arm bail into the indent of its cam. As the stop arm bail rotates about its pivot point, the attached stop arm is moved out of engagement with the clutch shoe lever. The selector cam-clutch engages and begins to rotate. The stop arm bail immediately rides to the high point of its cam where it remains to hold the start lever away from the selector armature during the signaling time. When the STOP impulse at the end of the signal is received, the selector armature is pulled up to block the start lever. Thus, the stop arm bail is prevented from dropping onto the low part of its cam (stop position of cam-clutch), and the attached stop arm is held so as to stop the clutch shoe lever. The selector cam-clutch disk upon which the latch lever follower rides has an indent at its STOP position. When the clutch shoe lever strikes the stop arm, the inertia of the cam disk assembly causes it to continue to turn until its lug makes contact with the lug on the clutch shoe lever. At this point, the latch lever drops into the indent in the cam disk, and the clutch is held disengaged until the next start interval is received.

(5) The series of five selecting levers and a marking lock lever ride their respective cams on the selector cam-clutch. As the marking and spacing signal intervals

are applied to the selector magnet, the selector cam-clutch rotates and actuates the selector levers. When a spacing interval is received, the marking lock lever is blocked by the end of the armature and the spacing lock lever swings toward the rear above the armature and locks it in the spacing position until the next signal transition is due. Extensions on the marking lock lever prevent the selector levers from following their cams (Figure 2-12). When a marking impulse of the signal is received, the spacing lock lever is blocked by the end of the armature and the marking lock lever swings to the rear below the armature to lock it in the marking position until the next signal transition is due. During this marking condition, the selector levers are not blocked by the marking lock lever extensions but are permitted to move against their respective cams. The selecting lever that is opposite the indent in its cam, while the armature maintains a marking condition, swings to the rear or selected position momentarily. Each selecting lever has an associated push lever which drops into a notch on the top of the selecting lever when it falls into its cam indent. As the selector cam-clutch turns, each selecting lever together with its latched push lever is moved toward the front and held there until all five code intervals have been received. At that time, all selected push levers have been positioned to the front and all unselected push levers have been positioned to the rear in which positions they are held until the next start interval is received. When the subsequent start interval again causes the selector cam-clutch to rotate, the push lever reset bail, in following its cam, unlatches the selected push levers. The push levers then return to the unselected (rear) position under their spring tension.

d. ORIENTATION.

(1) In order to establish the operating margins for the Typing Unit, it is necessary that the sampling of the signal by the selecting mechanism occur at the most favorable portion of the signal intervals. This is referred to as orientation.

(2) When the range finder knob (Figure 2-11) is pushed inward and rotated,

its attached range finder gear moves the range finder sector (which supports the stop arm bail, stop arm, and latch lever) either clockwise or counterclockwise about the selector cam-clutch. This changes the angular position at which the selector cam-clutch stops with respect to the selecting levers. When an optimum setting is obtained, the range finder knob is released. Its inner teeth engage the teeth of the indexing lock stud to lock the range finder mechanism in position. The setting may be read on the range scale opposite the fixed index mark.

e. PRINTING MECHANISM.

(1) CODE BAR MECHANISM.

(a) GENERAL. - The character which is to be printed is determined basically by the combination set up on the six code bars which are operated by the code bar positioning mechanism. In order to position the code bars, their associated shift bars must first be individually positioned toward the front or rear of the Typing Unit by transfer levers which respond to action of the selecting mechanism. While held in these positions, the code bar shift bars are moved either to the left or the right by code bar shift levers which are activated when the code bar clutch trip cam releases the code bar clutch. Detailed functioning of the coordinated mechanism follows:

(b) CODE BAR POSITIONING. - Each push lever (paragraph 4.c (5) of this section) has an associated intermediate arm, transfer lever, and code bar shift bar (Figure 2-13). In addition, there is a "common" transfer lever with its code bar shift bar. When a push lever is moved toward the rear (space position) its associated intermediate arm and transfer lever are pulled toward each other by a spring. This causes the transfer lever to turn counterclockwise about its pivot point. (Figure 2-13) and position its code bar shift bar toward the front of the Typing Unit (space position). When a push lever is moved to the front of the Typing Unit (mark position), it moves the intermediate arm toward the left. This causes the transfer lever to turn clockwise about its pivot point and position its code bar shift bar toward the rear of the Typing

Unit (mark position). The common transfer lever (Figure 2-14) has an extension which passes behind the number 1 and number 2 transfer levers (Figures 2-14 and 2-15). When either or both of these transfer levers are moved to the rear (mark position), they move the common transfer lever to the rear. This, in turn, moves the common code bar shift bar toward the rear of the Typing Unit (mark position). As the selector cam-clutch completes its revolution, the trip shaft operating lever (fastened to the code bar clutch trip shaft) rides to the peak of the code bar clutch trip cam (Figure 2-8). This causes the shaft to turn slightly and its attached code bar clutch trip lever releases the code bar clutch. Rotation of the clutch actuates the code bar shift levers through the intervening shift lever drive shaft, drive arm, and shift lever link (Figure 2-14). Code bar shift bars which have been moved toward the rear position by their transfer levers are engaged by the rear code bar shift lever and are shifted to the left. Code bar shift bars which have been moved toward the front position are engaged by the front code bar shift lever and are shifted toward the right (Figure 2-15). Thus, the six code bar shift bars shift their respective code bars toward the right or left where they are retained by a detenting mechanism. The code bar clutch one-stop cam disk, upon which the latch lever rides has an indent at its stop position. When the clutch shoe lever strikes the code bar clutch trip lever, the inertia of the cam disk assembly causes it to continue to turn until its lug makes contact with the lug on the clutch shoe lever. At this point, the latch lever drops into the indent in the cam disk and the clutch is held disengaged until the trip lever is again operated.

(c) ARRANGEMENT OF CODE BARS. - Three additional code bars bring the total number of code bars to nine. They are arranged from top to bottom as follows: Suppression, number 4, number 1, number 5, number 2, number 3, common, automatic carriage return and line feed, and shift-unshift (Figure 2-16). The automatic carriage return and line feed code bar and the shift-unshift code bar are actuated by mechanisms which will be discussed under FUNCTIONS.

(2) TYPE BOX AND TYPE BOX CARRIAGE.

(a) GENERAL.

1. The various characters and symbols printed by the Typing Unit are embossed on type pallets arranged in a compact, lightweight type box which may be readily detached for cleaning or replacement by a type box having a different set of characters or symbols (Figure 2-17). In operation, the type box, mounted on a type box carriage, is positioned both vertically and horizontally by the printing mechanism so that the character to be printed is aligned with the printing space. The five selecting elements of the 7.42 unit code are used to accomplish this alignment*.

2. The type box carriage rollers ride on a track which positions the type box vertically. The carriage is positioned horizontally on its track by the oscillating rail slide and type box carriage link. The slide rides the oscillating rail and is clamped to the rear section of the upper draw wire rope. The link provides a flexible connection to permit the type box carriage to follow both the vertical movement of the type box carriage track and the horizontal movement of the oscillating rail slide. The lower right rear end of the upper draw wire rope is fastened to the spacing drum. From this point, it passes part way around the spacing drum, upward and around the right oscillating rail pulley, over to the left oscillating rail pulley, and downward to the spring drum. After passing part way around the spring drum, the upper draw wire rope is doubled backward around it and passes upward to the left printing carriage rail pulley over to the right printing carriage rail pulley, and downward to the spacing drum to which it is again fastened. The lower draw wire rope is fastened at its left end to the spring drum and, at its right end, to the spacing drum. It acts in opposition to the upper draw wire rope and holds the two drums in phase (Figure 2-18). A tensioning pulley rides the under side of the lower draw wire rope, to take up any slack which may occur due to stretching of the upper and lower draw wire ropes. The oscillating rail is supported by pivoted arms at each end. These arms which extend downward are

pivoted on the typing unit frame at their lower ends. Thus, the oscillating rail and the draw wire rope that it carries may be shifted to the left or right with no change in position relative to each other. The oscillating rail shift slide and the two oscillating rail shift links are used to accomplish the horizontal positioning of the oscillating rail and also connect it with the oscillating rail shift slide. The links are pivoted and are of such a length that only one at a time may be fully extended. As will be shown later under FUNCTIONS, the oscillating rail shift links are used to position the oscillating rail and thus the type box, so that either the left side (letters characters) or the right side (figures characters) of the type box is selected.

(b) TYPE BOX POSITIONING. -

The selection of the various characters from the four horizontal rows and the eight vertical rows in either the left (LTRS) side or the right (FIGS) side of the type box and the printing of those characters take place as follows:

1. The left half of the type box, containing the alphabet, is brought into the printing position by the LETTERS code combination, and the right half, containing the figures and special symbols, is brought into the printing position by the FIGURES code combination. Essentially, the absence or presence of the No. 1 and No. 2 impulses in the selecting code determine which of the four horizontal rows will be positioned for printing; the No. 3 impulse determines which way the type box will be moved from the Figures or Letters centerline (to the left or right); the No. 4 and No. 5 impulses determine which vertical row is selected for printing. (Figure 2-19).

2. When the No. 1, No. 2, or Common code bar is in the spacing (right) position, it projects slightly beyond the edge of the right code bar bracket into the path of the right side "knee action" vertical positioning lever thus limiting the total rise of the lever. If none of the code bars are in the spacing position, the lever will be blocked in the topmost position by the Suppression code bar. Notches in the left end of each code bar are arranged so that the left side "knee

action" vertical positioning levers are in each case blocked by the same code bar that blocks the right side vertical positioning lever.

3. If the Typing Unit is not in the STUNT CASE, paragraph 4.j. (2), and all the code bars have been shifted to the marking or spacing position corresponding to the line signal variations, the code bar clutch cam follower arm roller in traversing the indent on the cam (Figure 20) causes the clutch trip lever shaft to rotate part of a revolution. As the shaft turns, the function clutch trip lever releases the stop lug on the function clutch. Then, the type box clutch trip arm engages its trip lever, releasing the stop lug on the type box clutch. Both clutches engage and commence rotating. By the time each clutch has completed one revolution, the code bar clutch cam follower arm roller has moved to the high portion of the cam, rotating the clutch trip lever shaft in the opposite direction and to its original position, returning the clutch trip levers to the stop position. When each clutch has completed one revolution, it is disengaged by its trip lever and latch lever in the same manner as was the code bar clutch; paragraph 4.e. (1). (b). of this section.

4. However, if the Typing Unit is in the STUNT CASE, paragraph 4.j. (a), at the time the code bar clutch follower arm roller traverses the indent on the cam, the suppression arm (Figure 2-20) will prevent sufficient rotation of the clutch trip lever shaft to cause engagement of the type box clutch. Consequently, the type box clutch will remain disengaged and printing cannot occur.

5. If the type box clutch is permitted to engage, motion is extended to a drive link and a bracket to cause the main rocker shaft to oscillate. This, in turn, through its left and right brackets and the main side lever drive links, extends the motion to the main side levers to operate the "knee action" vertical positioning levers (Figure 2-21). These levers are driven upward until they strike a projecting code bar which causes them to buckle. The type box carriage track is mounted between the vertical positioning levers and its vertical motion is controlled by them. When the number 1 and

number 2 code bars are toward the right (spacing), the common code bar is also toward the right where it blocks the vertical positioning levers. The top row of pallets in the type box are then in line for printing. When the number 1 code bar is toward the left (marking), and the number 2 code bar is toward the right (spacing), the common code bar is toward the left. The number 2 code bar blocks the vertical positioning levers, and the second row of pallets in the type box are then in line for printing. When the number 1 code bar is toward the right (spacing), and the number 2 code bar is toward the left (marking), the common code bar is also toward the left. The number 1 code bar blocks the vertical positioning levers and the third row of pallets in the type box are then in line for printing. When the number 1 and number 2 code bars are toward the left (marking), the common code bar is also toward the left. The suppression code bar blocks the vertical positioning levers, and the fourth or bottom row of pallets in the type box are then in line for printing. At each of the four levels at which the vertical positioning levers may be stopped, they are locked momentarily by lock levers which are controlled by the main side lever follower arms.

6. A bracket attached to the main rocker shaft applies vertical motion to the main bail by means of two main bail links (Figure 2-22). Attached to each end of the oscillating rail shift slide are pivoted, "buckling" type drive links which extend downward to each end of the main bail. As the main bail moves downward, the left shift slide drive links, if not buckled, will try to shift the oscillating rail shift slide toward the right while the right shift slide drive links, if not buckled, will try to shift the oscillating rail shift slide toward the left. When the number 3 code bar is shifted toward the left (marking), the horizontal motion reversing slide is shifted toward the left by the reversing slide shift lever, and is held there by detent levers. A bracket near the right end of the reversing slide will then make contact with the right shift slide drive links and cause them to buckle. As the main bail is driven downward, the unbuckled left shift slide drive links will start to shift the oscillating

rail shift slide toward the right. This positions the type box so that the character to be printed will be found in the left half of the LTRS or FIGS side. In a similar manner, when the number 3 code bar is shifted toward the right (spacing) the horizontal motion reversing slide is also shifted toward the right by the shift lever and is held there by the detent levers. A bracket near the left end of the horizontal motion reversing slide then makes contact with the left shift slide drive links and causes them to buckle. As the main bail is driven downward, the unbuckled right shift slide drive links will start to shift the oscillating rail shift slide toward the left. This positions the type box so that the character to be printed will be found in the right half of the LTRS or FIGS side.

7. After it has been thus determined in which group of four vertical rows the character to be printed is located, the number 4 and number 5 code bars operate three horizontal motion stop slides to determine the row in that group in which the character is to be found (Figure 2-22). A wedge shaped horizontal positioning lock lever which is pulled downward by the main bail through a yield spring, bears against the horizontal positioning lock lever arm. This arm drives the oscillating rail shift slide in the direction in which it was started (by the number 3 code bar selection) until one of the two decelerating slides which are mounted on the oscillating rail shift slide strikes an unselected horizontal motion stop slide. A camming surface on the unbuckled shift slide drive links makes contact with and rolls down the face of the decelerating slide and causes the drive links to buckle. The oscillating rail shift slide finally comes to rest when it strikes the blocked decelerating slide. This, in turn, ends the downward movement of the lock lever, and the yield spring is extended until the main bail reaches the lowest point of its oscillation. As the main bail returns upward, it centers the oscillating rail shift slide. It is during this time that the horizontal motion stop slides are positioned for the selection of the next character. The number 4 and number 5 code bars each operate a code bar bell crank. Each, in turn, moves a horizontal motion stop slide toward

the front (marking) or toward the rear (spacing) (Figure 2-23). A third (common) stop slide (spring tensioned toward the rear) is located between the upper and lower stop slides and has projections which pass across the front edges of these slides (Figure 2-22). Each stop slide is of a different length. The common stop slide, which is in the longest stop, has an additional step on its shank so that it serves as the shortest stop when all the slides are moved forward. The upper slide (operated from the number 4 code bar) is the second longest stop, and the lower slide (operated from the number 5 code bar) is the third longest stop.

8. When both the number 4 and the number 5 code bars are toward the right (spacing), their respective horizontal motion stop slides and the common stop slide are toward the rear. The oscillating rail shift slide is moved to the right or left of its central position (determined by the number 3 code bar) until it is stopped by one end of the common horizontal motion stop slide. This positions the first vertical row (right or left of FIGS center or LTRS center) in line for printing. When the number 4 code bar is toward the right (spacing) and the number 5 code bar is toward the left (marking), the lower and the common stop slides are toward the front and the upper stop slide is toward the rear. The oscillating rail shift slide is moved to the right or left of its central position until it is stopped by one end of the upper stop slide. This positions the second vertical row (right or left of FIGS center or LTRS center) in line for printing. When the number 4 code bar is toward the left (marking) and the number 5 code bar is toward the right (spacing), the upper and the common stop slides are toward the front and the lower stop slide is toward the rear. The oscillating rail shift slide is moved toward the right or left of its central position until it is stopped by one end of the lower stop slide. This positions the third vertical row (right or left of FIGS center or LTRS center) in line for printing. When both the number 4 and number 5 code bars are toward the left (marking), their respective horizontal motion stop slides and the common stop slide are toward the front. The oscillating rail shift slide is moved toward the right or left of

its central position until it is stopped by one side of the shank of the common stop slide. This positions the fourth vertical row (right or left of FIGS center or LTRS center) in line for printing.

(3) PRINTING HAMMER AND PRINTING CARRIAGE.

(a) GENERAL. - After the type box has been moved so that the selected type pallet is in its proper position, it must be struck by a printing hammer in order to print. This is accomplished by the action of the printing carriage located on the printing carriage track.

(b) PRINTING CARRIAGE POSITIONING. - The printing carriage rides (on rollers) on the printing carriage track which is rigidly attached to the typing unit front plate. The carriage is clamped to the forward section of the upper draw wire rope. This moves the carriage along its track in such a manner that the hammer advances to the next printing position.

(c) PRINTING. - The printing track which is located on the front of the Typing Unit (Figure 2-24) is fastened to an extension at each end of the main bail. As the main bail reciprocates vertically, it extends the motion to the printing track which travels in guides located at each end of the track. The printing arm, which extends downward from the printing carriage, rides the printing track. As the arm follows the reciprocating motion of the track, its upper end moves first toward the left and then toward the right. When the upper end of the arm moves toward the left, it rotates the printing hammer operating bail clockwise against its spring tension until it becomes latched by the operating bail latch (Figure 2-25). The printing hammer operating bail draws the printing hammer bail away from the type box by means of the printing hammer bail spring. When the upper end of the printing arm moves to its extreme right position, it makes contact with the latch and causes it to release the printing hammer operating bail. The operating bail is swung in a counterclockwise direction by the operating bail spring until it strikes its stop. The printing hammer bail, in being driven by the operating bail, is swung toward the type box. When the

operating bail is stopped, momentum causes the printing hammer bail to continue its travel against the tension of the printing hammer bail spring until the printing hammer strikes the selected type pallet.

f. SPACING.

(1) GENERAL. - To properly space the printed characters, the type box and printing carriages must be advanced with each character printed. As was shown in paragraph 4.e. (2) (a) 2. of this section and in Figure 2-18, the carriages are connected to a draw wire rope which, in turn, is fastened to the spring drum and the spacing drum. The purpose of the spring drum, which contains a torsion spring, is to tension the draw wire rope and thus the carriages to the left. The spacing drum has ratchet teeth about its periphery which are engaged by the eccentric driven spacing drum feed pawls (Figure 2-26). The spacing shaft, on which the spacing eccentrics are mounted, is driven through its helical gear by the helical driving gear attached to the three-stop spacing clutch on the main shaft. The gear ratio of 1-1/2 to 1 causes the spacing shaft to turn one-half of a revolution each time the spacing clutch is tripped. This allows the feed pawls to advance the spacing drum by the amount of one ratchet tooth. As shown previously, each time the Typing Unit operates, the main rocker shaft is made to oscillate about its center. A cam plate which is fastened to the lower side of the rocker shaft is in its lowest position during the rest time. During the time that printing is to take place, the cam plate is moved upward by the shaft and operates the spacing trip lever bail. As this bail is rotated about its pivot point, it raises the spacing trip lever until it latches onto the spacing clutch trip lever arm (Figure 2-27). As the rocker shaft reverses its direction of rotation, the spacing trip lever bail and the trip lever move downward thus causing the latched-up spacing clutch trip lever arm to operate the spacing clutch trip lever and release the spacing clutch. Before the spacing clutch completes one-third of a revolution, its restoring cam moves the spacing trip lever about its pivot point until it releases the spacing clutch trip lever arm. This, in turn, releases the spacing clutch trip lever which returns to its normal

position in time to stop the spacing clutch after one-third of a revolution. The spacing clutch three-stop cam disk upon which the latch lever rides has an indent at each stop position. When one of the three lugs on the clutch shoe lever disk strikes the spacing clutch trip lever, the inertia of the cam disk assembly causes it to continue to turn until its lugs make contact with the lugs on the clutch shoe lever disk. At this point, the latch lever drops into an indent in the cam disk and the clutch is held disengaged until the trip lever is again operated.

(2) SPACING SUPPRESSION. - When certain functions are selected or when the carriages reach their extreme right positions, it is necessary to suppress spacing. This is accomplished by moving the spacing suppression slide forward. In this position, it will hold the upper end of the spacing trip lever forward and prevent it from engaging the spacing clutch trip lever arm. In the case of spacing suppression on functions, the spacing suppression slide is shifted by means of a spacing suppression bail. The manner in which this bail is operated will be discussed under FUNCTIONS. When the carriages are near their extreme right positions, an adjustable cutout lever on the spacing drum engages the spacing cut-out transfer bail which, in turn, operates the spacing cut-out bail. The adjustable spacing cut-out lever and the end of the spacing cut-out transfer bail are shown in Figure 2-18. The spacing cut-out bail shifts the spacing suppression slide and prevents spacing until the carriages are returned. The maximum number of characters which the Typing Unit may print in one line is eighty-five. In order to prevent spacing beyond this point several teeth are omitted from the spacing drum ratchet wheel.

g. MARGIN INDICATOR. - Before the type box carriage and the printing carriage reach the end of their travel, the margin indicator light in the Cabinet is illuminated. The contact mechanism which controls the lamp circuit is mounted on the Base and is fully described in paragraph 3. e. of this section. The actuator of this contact mechanism is a disk which is mounted on the spring drum of the Typing Unit (Figure 2-18). The angular position of this cam disk with respect to the

spring drum may be altered to change the point at which the indicator will light.

h. RIBBON MECHANISM.

(1) POSITIONING. - The left and right ribbon feed mechanisms oscillate in a vertical plane with each revolution of the type box clutch. They are driven by ribbon drive links which are attached to the main side levers (Figure 2-28). At their uppermost position, the ribbon mechanisms position the ribbon relative to the line which is being printed. After each character is printed, the ribbon mechanisms are dropped downward together with the type box in order that the last character printed may be viewed. The ribbon is held in place at the point of printing by a ribbon guide which is fastened to the rear of the type box carriage.

(2) FEEDING. - Each of the ribbon mechanisms includes a bracket which is hinged at its rear end, and upon which a ribbon spool shaft is mounted (Figures 2-28 and 2-29). A ribbon tension bracket is keyed to the lower end of the ribbon spool shaft. A ribbon ratchet wheel is mounted freely on the ribbon spool shaft just below the ribbon spool bracket from which it is separated by a friction washer. The ratchet wheel friction spring on the under side of the ribbon ratchet wheel causes the ratchet wheel to bear against the felt friction washer. This applies a constant drag to the ratchet wheel. A ribbon tension plate which is keyed to the hub of the ribbon ratchet wheel has two projecting lugs (A and B in Figure 2-29) that straddle the lug on the ribbon tension bracket. A ribbon tension spring tends to maintain the ribbon tension bracket against lug A of the ribbon tension plate. In operation, the ribbon spool bracket, driven by the ribbon drive link, pivots about point A in Figure 2-28. The ratchet feed and ratchet detent levers pivot about points B and C respectively, and are held against the saw-tooth shaped teeth on the ribbon ratchet wheel by their springs. As the ribbon spool bracket is moved upward, the ratchet wheel feed lever skips over one tooth, while the ratchet detent lever holds the ribbon ratchet wheel from turning backward. When the ribbon spool bracket is moved downward,

the ratchet feed lever engages a ratchet tooth and pushes the ratchet wheel. A tooth on the ribbon ratchet wheel then skips over the ratchet detent lever. The teeth on the left and right ribbon ratchet wheels face in opposite directions so that, when their feed levers are engaged, the left ribbon ratchet wheel turns clockwise and the right ribbon ratchet wheel turns counterclockwise (viewed from the top). In order for the ribbon to be pulled from one ribbon spool to the other, only one of the ribbon mechanisms at a time can have its ratchet feed and ratchet detent levers engaged with its ribbon ratchet wheel. As the ribbon ratchet wheel turns (Figure 2-29), the ribbon tension plate also turns, and extends the ribbon tension spring. When the lug B of the ribbon tension plate makes contact with the ribbon tension bracket, the ribbon spool shaft is made to turn and the ribbon is thus wound on the ribbon spool. When the ribbon has become completely unwound from one spool, it is necessary to reverse its direction so it can rewind. This is accomplished automatically by disengaging one set of ratchet feed and ratchet detent levers and engaging the other set. While the ribbon is passing from the left spool to the right spool, the right set of levers are engaged. The left set are held disengaged against the tension of their springs by the left ribbon feed reverse lever which is in its downward position (Figure 2-31). The lever is held in this position by means of the ribbon reverse detent lever through the intervening ribbon reverse detent cam, ribbon reverse shaft, and ribbon reverse spur gear. As the ribbon unwinds from the ribbon spool, it passes around the ribbon roller (Figure 2-30) and through the slot in the end of the ribbon lever. When the ribbon nears its end on the ribbon spool, an eyelet which is fastened to the ribbon, catches in the ribbon lever slot and pulls the lever toward the right. The next time the ribbon mechanism is moved upward, the displaced ribbon lever engages the end of the left ribbon reversing lever and causes it to move to the dashed position shown in Figure 2-31. As the lever moves, its teeth rotate the left spur gear which, through the ribbon reverse shaft, turns the detent cam and the right spur gear. As the right spur gear moves the right ribbon reversing lever downward, a pin on the lever drives

the right ribbon feed reverse lever downward to disengage the ratchet feed and ratchet detent levers from the right ribbon ratchet wheel. At the same time a pin on the left ribbon reversing lever moves the left ribbon feed reverse lever upward to permit the left ratchet feed and ratchet detent levers to engage the left ribbon ratchet wheel. Thus, the ribbon mechanisms are positioned to rewind the ribbon on the left ribbon spool. When it nears its end on the right ribbon spool, the ribbon is again reversed in a manner similar to that just described. During the reversing cycle the ribbon is maintained taut by the previously extended ribbon tension spring (Figure 2-29).

i. FUNCTIONS.

(1) GENERAL.

(a) Essentially, the operations performed within the Typing Unit can be divided into two distinct classifications; those which are directly concerned with the actual imprinting of a character and those which result in line feed, carriage return, space, figures - letters shift, etc. The latter operations are known as functions.

(b) As in printing, the reception of a function code combination positions the code bars in accordance with the marking and spacing intervals of the signal. A series of square notches extends across the rear edge of each code bar. The stunt box (Figure 2-32), containing the function bars, is positioned directly behind the code bars. The front edge of each function bar has a series of tines which are offset to one side or the other. After the code bars have been positioned, the function bars are allowed to bear against the code bars. Only the function bar with the correct arrangement of tines will enter the notches in the code bars. All other function bars will be blocked by one or more code bars.

(c) When the function clutch is tripped, (Figure 2-20 and paragraph 4.e. (2) (b) 3, of this section) it rotates and imparts motion to the function bar reset bail through the intervening cam and follower arm, and function rocker shaft (Figure 2-33), causing the function

bar reset bail with an attached reset bail blade to momentarily release the function bars. As the spring tensioned function bars are released, they move forward to bear against the code bars. If the code bars are positioned for a particular function, each tine on the function bar for that function will be opposite a notch in a code bar. This will permit the selected function bar to enter the code bars while the others are blocked by one or more code bars (Figure 2-34). A function pawl and function lever are associated with each function bar.

(d) In the unselected position, the function pawl is not engaged by its function bar but is in the forward position where its rear end rests on the function bar tail (Figure 2-35). When the function bar reset bail blade releases the function bars and the selected function bar moves forward, the function pawl drops off the function bar tail. As the reset bail blade returns the selected function bar to the rear, the engaged function pawl is carried to the rear. The function pawl pivots the function lever clockwise. A projection on the lower end of most function levers engages the space suppression bail and pushes the bail forward to suppress spacing, paragraph 4.f. (2). This extension of the function lever is omitted when spacing on a function is desired. Near the end of the function cycle, the stripper blade, operated by a cam on the function clutch assembly, rises beneath the rear edge of any selected function pawl and strips it from its function bar. Springs return the released function pawl and the function lever to their original positions (Figures 2-36 and 2-37). It should be noted here that, to prevent printing during the function cycle, whenever a function selection occurs the type box is positioned such that the printing hammer will strike where there is no type pallet. The function clutch is disengaged upon completion of one revolution as described in paragraph 4.e. (2) (b) 2.

(2) LETTERS AND FIGURES SHIFT FUNCTION.

(a) The letters and figures function bars, pawls, and levers which are located near the right end of the Stunt

box operate on letters and figures codes respectively. The upper ends of the function levers engage the letters and figures function slides (Figures 2-38 and 2-39). The front ends of these function slides have camming surfaces which, when a slide is shifted to the rear by its function lever, move the letters-figures code bar fork to the right (letters position - Figure 2-38) or to the left (figures position - Figure 2-39). The letters-figures code bar fork engages a pin on the bracket which is fastened to the letters-figures shift code bar, and positions the code bar toward the right for letters function or toward the left for figures function (Figure 2-40). A slotted extension of the code bar engages a tongue from the right end of the letters-figures shift slide and causes the shift slide to follow the movements of the code bar. Pins at the end of the shift slide serve as lower guides for the right and left shift link breaker slides. Pins which project from the front plate serve as upper guides and pivot points. Mounted on the ends of the main bail are the left and right breaker slide bails. When the letters function code is received, the shift slide is shifted to the right as shown. This places the left shift link breaker slide in a vertical position with its lower end over the left breaker slide bail. The right breaker slide is positioned such that its lower end is to the right of the right breaker slide bail. As the main bail moves upward, the right breaker slide bail clears the right breaker slide while the left breaker slide bail engages the left breaker slide and moves it upward. This action causes the left oscillating rail shift links to break and shift the oscillating rail to the right for the printing of LTRS characters. In a similar manner, when the figures function code is received, the right oscillating rail shift links are broken and the rail is shifted to the left for the printing of FIGS characters.

(3) CARRIAGE RETURN FUNCTION.

(a) The carriage return function mechanism is located in the right end of the Typing Unit. Reception of the carriage return code causes the carriage return function bar, pawl, and lever to operate (Figure 2-41). The lower end of the function lever engages the carriage

return slide arm and pushes it forward (toward the left in the figure). The slide arm, in turn, moves the carriage return bail and its lever about their pivot point. As the front portion of the lever moves downward, it takes with it the lower section of the spacing drum feed pawl release link. This causes the upper portion of the link to turn and disengage the spacing drum feed pawls from the spacing drum (Figure 2-42). When the carriage return lever reaches its lowest point, the carriage return latch bail locks it there. The disengagement of the spacing drum feed pawls from the spacing drum permits the spring drum to return the printing and type box carriages toward the left side of the Typing Unit. As the spacing drum nears the end of its counterclockwise rotation, the roller on its stop arm contacts the transfer slide which, in turn, drives the dashpot piston into the dashpot cylinder. A small passageway with an inlet from the inside of the cylinder and three outlets to the outside is incorporated in the end of the cylinder. Two of the openings to the outside are closed by a steel ball which is held in its seat by means of a compression spring. A set screw which may be locked in place with a nut is used to regulate the spring pressure on the ball. The rate of deceleration provided by the cushioning effect of the trapped air is automatically regulated for various lengths of lines by means of the ball valve. This together with the direct opening to the outside, determines the rate at which the air may escape from the cylinder. When the spacing drum reaches its extreme counterclockwise position, an extension on the stop arm trips the carriage return latch bail plate which is fastened to the carriage return latch bail. The latch bail, disengages the carriage return lever and the feed pawls are again permitted to engage the spacing drum.

(b) Local (off-line) operation of the carriage return mechanism may be obtained from the Base. The mechanism described in paragraph 3.c. of this section engages a projection on the carriage return lever and causes the operations described in the preceding paragraph to take place.

(4) LINE FEED FUNCTION.

(a) The line feed function mechanism is located in the left end of the Typing Unit. The reception of the line feed code causes the line feed function bar, pawl, and lever to operate (Figure 2-43). The lower end of the line feed function lever engages the line feed slide arm and pushes it forward (to the left in the figure). The slide arm, in turn, moves the line feed clutch trip arm and the trip lever about their pivot point until the trip lever releases the three-stop line feed clutch. The line feed gearing is such that each one-third revolution of the clutch will advance the platen by one line. Therefore, the length of time that the line feed clutch trip lever is held away from the clutch will determine the number of line feeds that occur. The timing relationship between the stripper blade cycle and the main shaft rotation is such that the function pawl is not stripped from a function bar by the stripper blade until after more than one-third of a revolution of the clutch has occurred. Thus, the line feed clutch trip lever will stop the clutch after two-thirds of a revolution, or double line feed, has occurred. When single line feed is desired, it is necessary to strip the function pawl from the line feed function bar before the line feed clutch completes one-third of a revolution. This is accomplished by the use of an auxiliary line feed function pawl stripper which is attached to the stripper bail. The stripper bail arm is shifted to the left or to the right by the single-double line feed operating arm (Figure 2-44). When the lever is in position 1 (toward the front of the Typing Unit) the stripper bail arm is permitted to engage the slot in the auxiliary line feed stripper. When the lever is in position 2 (toward the rear of the Typing Unit) the stripper bail arm is shifted out of the slot in the auxiliary line feed stripper. The cam disk on the three stop line feed clutch operates the auxiliary stripper bail once each one-third revolution of the line feed clutch. If the stripper bail arm is inserted in the auxiliary stripper slot, it will strip the selected line feed function pawl from its respective function bar immediately after the stop lug on the line feed clutch is released. The clutch revolves only one-third of a revolution and is then disengaged by the clutch trip lever.

(b) When single line feed is being used, the line feed function lever is released too soon (by the line feed function pawl stripper) to prevent spacing. Therefore, an additional line feed function bar, pawl, and lever are installed in the extreme left end of the Stunt box for the sole purpose of suppressing spacing on single line feed function (Figure 2-32). This mechanism, which always operates on the line feed function code, is released only by the stripper blade, and therefore holds the spacing suppression bail operated until the spacing cycle is completed. After the line feed clutch is stopped by its trip lever, it is disengaged by the trip lever and latch lever in the same manner as the three-stop spacing clutch.

(c) Each one-third revolution of the line feed clutch causes its attached spur gear to rotate the line feed eccentric spur gear and its attached eccentrics one-half of a revolution (Figure 2-45). The eccentrics, which are offset in opposite directions, each carry a line feed bar. These bars, guided by the line feed bar bell crank, alternately engage the line feed spur gear on the platen and advance the platen one line for each one-half turn of the eccentrics. A platen detent bail engages the line feed spur gear to retain the platen at each setting.

(d) When it is desired to manually position the platen, this may be accomplished by bearing down on and turning the platen handwheel. This causes the platen handwheel spur gear to engage the platen idler spur gear which, in turn, is engaged with the platen spur gear on the platen shaft. At the same time, the line feed bar release lever bears on the line feed bar bell crank and causes it to disengage the line feed bars from the line feed spur gear.

(e) Local (off-line) operation of the line feed mechanism may be obtained from the Base. A mechanism, described in paragraph 3.d. of this section, engages a projection on the line feed clutch trip lever and, when operated, will hold the clutch engaged to provide continuous line feeding (Figure 2-43).

(5) AUTOMATIC CARRIAGE RETURN - LINE FEED FUNCTION.

(a) If an operator fails to send the carriage return and line feed function before the type box and printing carriages are within one character space from the right end of the line, the automatic carriage return arm on the spacing drum trips the automatic carriage return bell crank (Figure 2-42). As the bell crank turns clockwise, it shifts the automatic carriage return-line feed code bar to the right. Located adjacent to the carriage return and to the line feed function bars in the stunt box are the automatic carriage return and line feed function bars (Figure 2-32). These two function bars are identical and have only one code projection. This projection is located opposite the automatic carriage return-line feed code bar which normally blocks the automatic carriage return and line feed function bars. When the code bar is shifted to the right these function bars and their associated function pawls and levers are operated. The automatic carriage return and line feed function levers operate the carriage return slide arm and the line feed slide arm respectively and thereby cause the carriage return and line feed functions to occur simultaneously.

(b) In the process of sequential station selection, the CR code combinations of the CONDITION CODE sequence cause normal operation of the carriage return mechanism. The AUTO CR-LF (automatic carriage return-line feed) code bar is used as a "gate". The first function bar in the selecting portion of each station or area call is coded with a tine which prevents its selection until the Auto CR-LF code bar is shifted to the right by a shift lever slide when the LTRS code combination of the CONDITION CODE is received. It is held in this position only long enough for the first function bar in the selecting portion of the station or area call to be selected. The AUTO CR-LF function bars are blocked by a blocking slide which prevents their selection when the CONDITION (AUTO CR-LF) code bar is shifted. This slide is moved into position by the same shift lever slide used to shift the CONDITION code bar in its "gating" operation. The blocking slide is returned to its normal position by a spring as is the shift lever slide.

(6) SIGNAL BELL FUNCTION.

(a) The Typing Unit must be out of the STUNT CASE in order to operate the signal bell. The circuit to the signal bell magnet is controlled by a set of normally open electrical contacts mounted on the Stunt box (Figure 2-46). The signal bell function bar has six code lugs - five for the signal code which may be either S or J and one for the letters-figures shift code bar (Figure 2-32). In order to select the signal bell function, the letters-figures shift code bar must first be shifted to figures position. Then, each time the signal code for the letter S (or J) is received, the function lever will pulse the upper signal bell contact once (Figure 2-47). If the signal code for the letter S (or J) is received when the letters-figures shift code bar is in the letters position, the signal bell function bar will be blocked by the shift code bar.

j. SEQUENTIAL SELECTION MECHANISM. - The principal function of the stunt box mechanism is to initiate the performance of the basic functions essential to printing; i.e. line feed, carriage return, etc. Other functions, such as sequential selection of a station or function and remote control operation of auxiliary and associated apparatus, are accomplished by the stunt case mechanism which in some respects is similar to the common function mechanisms.

(1) GENERAL.

(a) Whether sequential selection of a station, function, or supplementary equipment is involved, the method and means are essentially identical. In order to activate and select a particular function bar, it is first necessary to follow a sequence of selection which removes a blocking projection from the path of the final function bar selected. When this function bar is allowed to operate and is selected, it operates a function lever which in turn operates a bail, or slide, switch, lever, etc.

(b) An example of a typical sequential selection mechanism in operation is illustrated in Figure 2-48. At the instant shown, the first character of the selecting sequence has been received;

the function pawl of the selected function bar has forced the first function lever to pivot clockwise. This removes the projection blocking forward movement of the adjacent (second) function bar. The latch lever locks the first function lever in the operated position, preventing the function lever from returning to the unoperated position as the stripper blade rises and strips (disengages) the function pawl from its function bar. While the function lever is held in its operated position, the second function bar can be selected by the second character of the selecting sequence, initiating a similar chain of events. While the second function bar is being selected, the stripper blade descends and strikes the latch lever arm which releases the first function lever. Should a character be interposed between the first and second character of the selecting sequence, the projection blocking forward movement of the second function bar will be replaced and prevent selection of this function bar by the second character of the selecting sequence.

(c) While the second function lever is latched in the operated position, the third consecutive character of the selecting sequence will position the code bars to allow operation of the third function bar which through its function lever activates a switch, slide, lever, bail, etc.

(2) STATION SELECTION.

(a) An adaptation of the sequential selection mechanism, paragraph 4. j. (1), coupled with a Stunt Case mechanism constitutes a built-in station selector. The number of characters in the selecting sequence is dictated solely by the degree of reliability desired to obtain selection without error. For the system in which this printer is to operate, it was deemed advisable to have a six character selecting sequence. Each printer must be capable of responding to several different selecting codes. Some printers will be required to respond to only one station call and one area call (Section I, Paragraph 2.). Others, will be required to respond to two station and two area calls. Because of space limitations in the stunt box, it was impossible to provide entirely different selecting code sequences for each call.

Instead, all selecting codes have a common three character sequence, CR-CR-LTRS (CONDITION CODE) followed by a three character sequence which is unique for each selecting code sequence.

(b) The first character of the CONDITION CODE, (CR) removes a blocking projection from the path of an adjacent function bar which is also coded for the CR combination. The second CR combination removes a blocking projection from the path of a third function bar coded with the LTRS combination. Upon receipt of the third character (LTRS) the unblocked function bar operates and moves its function pawl and function lever rearward. Attached to the top of the function lever is a shift slide arm which momentarily shifts the spring biased automatic carriage return and line feed code bar to the left. All function bars which are coded with the first character of a selecting code have a projection (tine) which prevents their selection unless the automatic carriage return and line feed code bar is shifted to the left. While the automatic CR-LF code bar is temporarily shifted, the first character of the selecting code positions the code bars to select the corresponding function bar. This function bar operates and removes the projection blocking the adjacent function bar which is coded with the next character of the selecting code. After the first function bar has been operated, the AUTO CR-LF code bar is returned to its original position by its bias spring. Thus, the "gate" has been opened only long enough for the first character of the selecting code to operate. All function bars responding to the first character of the selecting code have an extra tine which prevents their selection unless the AUTO CR-LF code bar is shifted. This prevents inadvertant selection of a selecting code function bar. The third character of the selecting code operates the STUNT CASE mechanism.

(c) If the Typing Unit is not in the STUNT CASE when the Condition Code is received, the CR code combinations will cause carriage return to occur as before. The LTRS code combination will cause operation of the AUTO CR-LF code bar as before, but presumably the selecting code will not be intended for this printer. However, the LTRS code causes line feed to occur

as well as shifting the typing mechanism to the letters case. The selecting code characters will be printed as well as all subsequent messages until printing is deactivated by the END OF MESSAGE CODE.

(d) When the Typing Unit is in the STUNT CASE, printing is suppressed by blocking release of the type box clutch during the normal operating cycle. Printing is activated by removing the obstruction (Figure 7) preventing engagement of the type box clutch. The suppression (top) code bar operates the suppression mechanism. The last character of a selecting code operates a shift lever slide which shifts the suppression code bar to the right. In this position, the blocking bail extension does not interfere with the movement of the suppression arm attached to the clutch trip arm. The function lever controlling the shift lever slide is locked in position by a lock lever as shown in Figure 2-49. These lock levers are unlatched only upon receipt of the END OF MESSAGE sequence.

(e) There are two sets of function levers coded with the END OF MESSAGE sequence. When the END OF MESSAGE sequence is received by the printer, the process of sequential selection results in successive operation of the FIGS-CR-LTRS coded function bars. The function lever associated with the LTRS function bar in each set has a horizontal extension with a hole in the extreme end on its lower rear portion. A rod fitted through the holes and between the two levers forms a bail (Figure 2-49) called the latch release bail. With the printer out of the STUNT CASE, the spring biased suppression code bar is moved to the right by one of the shift lever slides and locked in this position. The function lever operating the shift lever slide is locked by a latch lever with a long tail. This type latch lever is not unlatched by the stripper blade but only by the latch release bail. The END OF MESSAGE sequence causes operation of the latch release bail which allows the suppression code bar to shift automatically to the left. In this position the blocking bail extension obstructs movement of the suppression arm and so prevents release of the type box clutch, i.e. the printer is in the STUNT CASE.

(f) The LOCAL-REMOTE switch provides local off-line control of the STUNT CASE shift mechanism. The switch controls a solenoid mounted on the left side frame. In the LOCAL position, the solenoid is energized directly from the motor terminal block by 115 volts A.C. When energized, the solenoid pivots the blocking bail lever which bears against the blocking bail arm and forces the suppression code bar to the right. Printing is immediately activated even if the END OF MESSAGE sequence is received. In the REMOTE position, control of the solenoid is transferred to auxiliary or associated apparatus. If no voltage is being applied to the terminals when the switch is placed in the REMOTE position, the Typing Unit will shift out of the STUNT CASE unless it has been previously selected to receive a message. Upon completion of the message and receipt of the END OF MESSAGE sequence, the unit will shift to the STUNT CASE. If a voltage is being applied when the switch is closed in the REMOTE position, the unit will be shifted from the STUNT CASE. In summary: Printing cannot be suppressed when the switch is in the LOCAL position. Printing can be suppressed when the switch is in the REMOTE position only when no voltage is being applied externally to the solenoid.

(3) REMOTE CONTROL SWITCHING.

(a) A number of electrical switches installed on top of the stunt box are used for remote control of associated and auxiliary apparatus. These switches are operated by the tops of the function levers which act as cams. A bakelite piece on the end of each contact arm rests on the top of the function lever which is to operate it. The shape of the bakelite piece determines whether it is a normally open or normally closed switch (Figure 2-49).

(b) The switches can be operated by sequential selection or direct selection. They can be maintained in the closed (normally open switch) or open (normally closed switch) position for an indefinite period by latching the function lever in the operated position. Otherwise, contact is maintained for only an instant. To release a switch that has been locked in the operated position, it is necessary

to operate the latch release bail. Generally, any switch that must be locked in the operated position is associated with a function lever that is latched for some other reason. The function levers which operate the STUNT CASE mechanism (shift lever slides) are of this type.

(c) When a message is to be sent from one area network into another, it must pass through a relay station where it is recorded by a Reperforator Transmitter Distributor in tape and retransmitted. The line relay of the reperforator portion is controlled by a normally closed switch on the stunt box which is opened and latched when the relay station's call is received. After the message is completed, the END OF MESSAGE sequence is received which not only puts the receiving printer in the STUNT CASE but also shunts the line relay of the reperforator.

5. MOTOR UNIT. (Figure 2-50.)

a. GENERAL. - The Motor Unit, mounted at the rear of the Base, is the source of motive power for the Typing Unit.

b. RATING. - The synchronous motor is rated:

Single phase; 115 volts; 60 cycle A.C.; *
1/20 H.P.; 3600 RPM
Starting Current: - 9.0 AMPS
Running Current: - 1.85 AMPS
Power Factor: - 0.30; Watts: - 65 Watts

* To avoid loss of receiving margin, the frequency must be maintained $\pm .75\%$

c. COMPONENTS. - The motor is of the capacitor start synchronous type; a two pole wound stator with a squirrel cage rotor. The stator has two windings; a main operating or running winding and an auxiliary or starting winding. A 43 mfd. a.c. electrolytic capacitor and a starting relay are connected in series with the starting winding. Two fans located within the motor frame, one at each end of the rotor, draw cooling air in through the slots in the end bells, and exhaust it through the slots in the stator frame.

d. STARTING. - On starting, the initial surge of current causes the starting relay to operate and close the contacts in the

starting winding circuit. As the rotor accelerates, the starting current decreases. At approximately 5.7 amperes, the relay armature releases and opens the starting winding circuit. The rotor continues to accelerate until it reaches synchronous speed. Rotation is counter-clockwise as viewed from the handwheel end.

e. **OVERLOAD RESET.** - If the motor draws excessive current for a prolonged period, i.e. a blocked rotor, a thermal cutout switch will open and disconnect the motor from the a.c. supply. This prevents overheating and possible damage to the motor. The switch can be reset by pressing the manual reset button projecting through the motor mounting plate.

6. ELECTRICAL SERVICE UNIT.

a. **GENERAL.** - The Electrical Service Unit consists of a chassis fabricated from sheet metal upon which is attached such accessories as a line shunt relay, line relay, rectifier, fuses, receptacles, etc.

b. **LINE RELAY.** - The line relay receives the signals directly from the signal line. The signal is repeated and relayed to the selector magnets on the Typing Unit. The selector magnets are connected in series for 30 milliamperere operation.

c. **LINE SHUNT RELAY.** - The line shunt relay shunts the signal line when the power switch is switched OFF. When the power switch is turned on, the relay is energized and removes the shunt. Signals are no longer shunted past the line relay.

d. **RECTIFIER.** - The rectifier is rated:

Input: 115 volts A.C.; 60 cycles; 23 watts

Output: 120 volts D.C.; 120 milliamperes

The rectifier has sufficient output to supply current for the selector electromagnets and the bias winding of the line relay. However, there is not sufficient capacity to supply the signal line current in addition to the other requirements.

e. **CABLES.** - The cable assembly extending from the right top side of the Electrical Service Unit is plugged into the receptacle on the right side frame of the Typing Unit. This connects the line relay to the selector magnets and also provides

connection to the switches located on the stunt box. The cable extending through the left top plate connects to the Base, supplying power to the Motor Unit as well as connection to the end of line indicator switch. The cable with lug terminals extending from the right side of the Electrical Service Unit connects with the right half of the Cabinet terminal board. This cable connects A.C. power to the Electrical Service Unit and completes the circuits to various electrical components in the Cabinet. The cable with lug terminations extending from the left side of the Electrical Service Unit connects with the left half of the Cabinet terminal board to bring all signal line circuits into the Electrical Service Unit.

f. **FUSING.** - Upon entering the Electrical Service Unit, the power input is fused by one 4 ampere fuse. However, the convenience outlet is unfused.

g. **SIGNAL CURRENT.** - The equipment is wired for 60 milliamperere signal line current operation but may be adapted to 20 milliamperere signal line current by connecting an 8000 ohm resistance in the unit (two 4000 ohm resistors) in series with the line relay bias winding.

7. CABINET.

a. **GENERAL.** - The Console Cabinet serves as a housing for the Base, Typing Unit, Motor Unit, and Electrical Service Unit. All electrical connections to the various components are made through the two terminal boards mounted across the upper rear portion of the Cabinet. The two functional block diagrams illustrate distribution of the power and line signals (Figures 2-1 and 2-2).

b. **SIGNAL BELL.** - The signal bell is located on the bottom of the soundproofed compartment. The signal bell magnet is connected to the Typing Unit through the Cabinet terminal board and is operated by contacts mounted on the stunt box. The signal bell operates only when the Typing Unit is out of the Stunt Case.

c. **POWER SWITCH.** - The Power Switch, located in the lower front corner of the right end of the Electrical Service Unit, is engaged by the fork on the power switch

extension shaft. This shaft extends through the front of the Cabinet below the right end of the front cover and is furnished with a knob so that the power may be turned OFF or ON without opening the dome.

d. COPY LIGHT. - The copy light lamps and switch are located in the Cabinet dome. When the power switch is OFF, the copy lights may be turned ON during maintenance operations by throwing the lamp

switch to the MAINT ON position. When the printer is in normal operation, the lamp switch is placed in the NORMAL ON position. The copy lights are then controlled by the power switch.

e. MARGIN INDICATOR. - The margin indicator lamp is also located in the Cabinet dome. This lamp is controlled by a switch mounted on the base (Paragraph 3.e. of this section).

225B

SECTION 3

FIGURES

FOR

SECTIONS 1 AND 2



Figure 1-1. Model 28 Receiving - Only Printer
(Stunt Case C.A.A.)

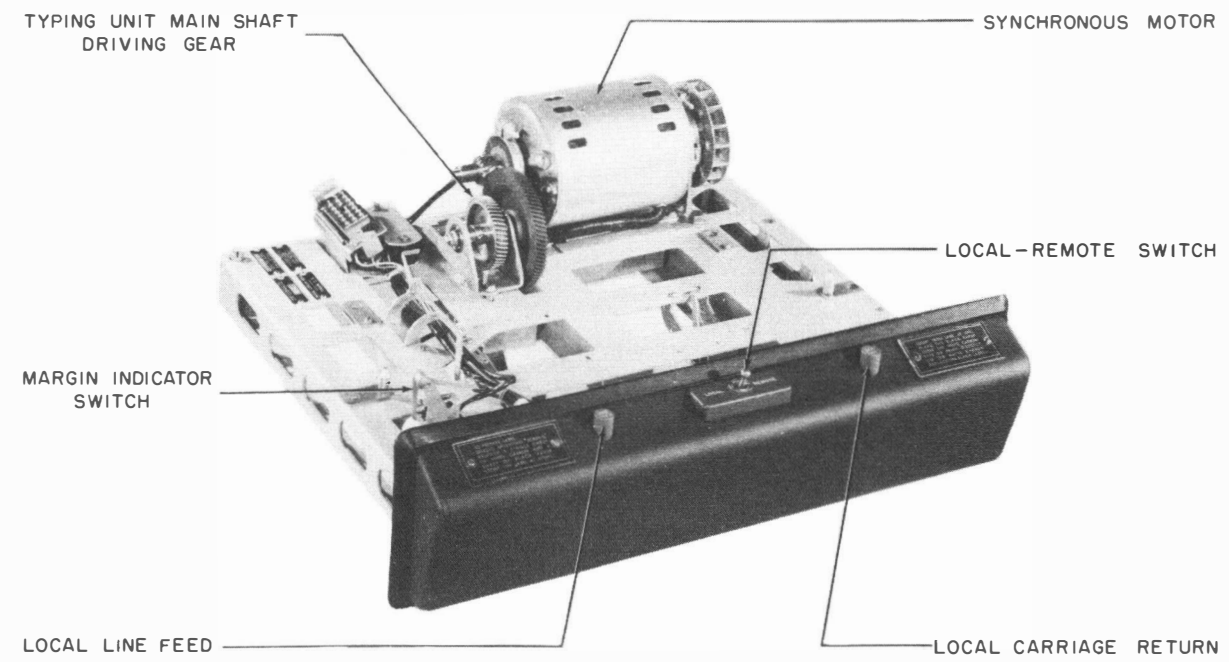

Figure 1-2. Receiving - Only Base With Motor Unit

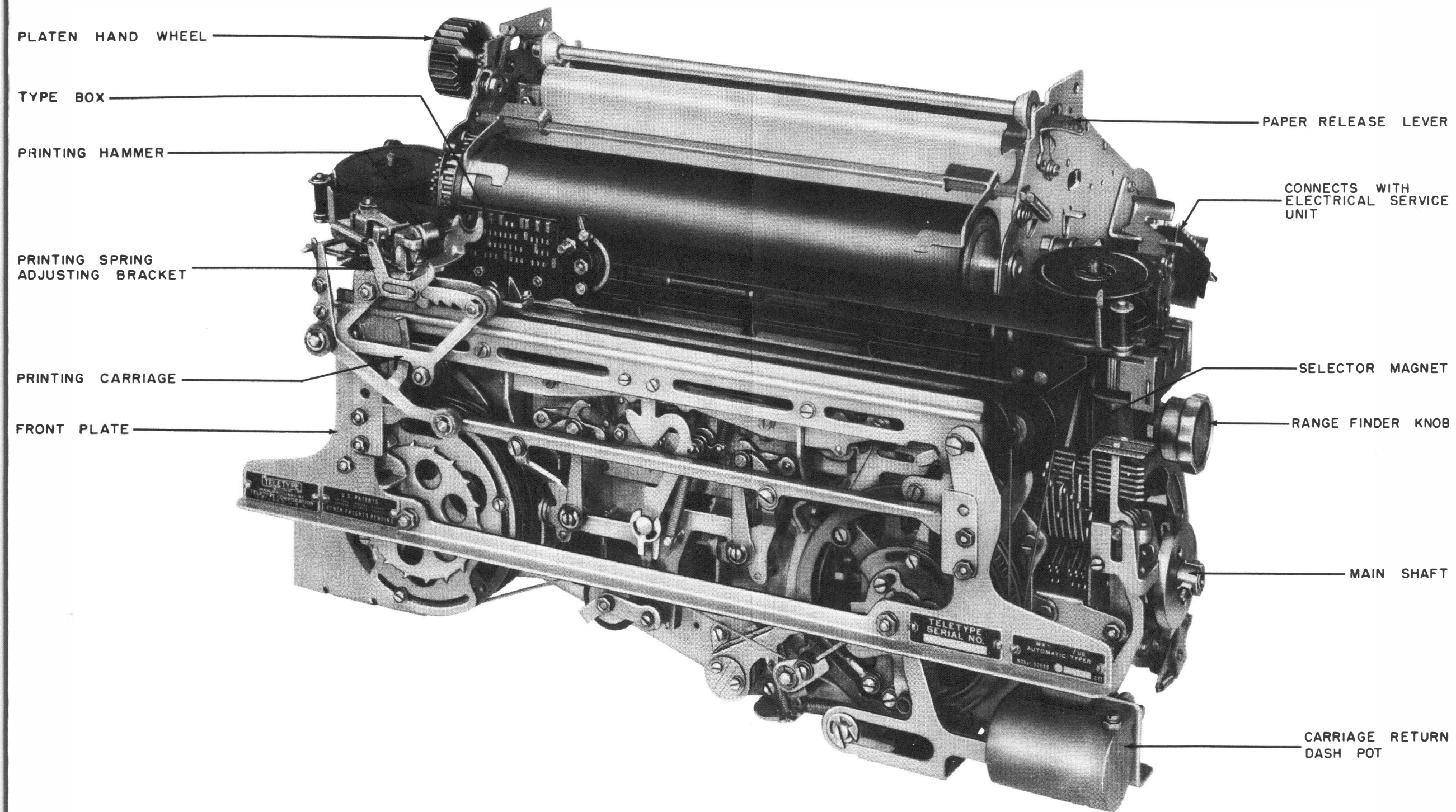

Figure 1-3. Typing Unit, Front View

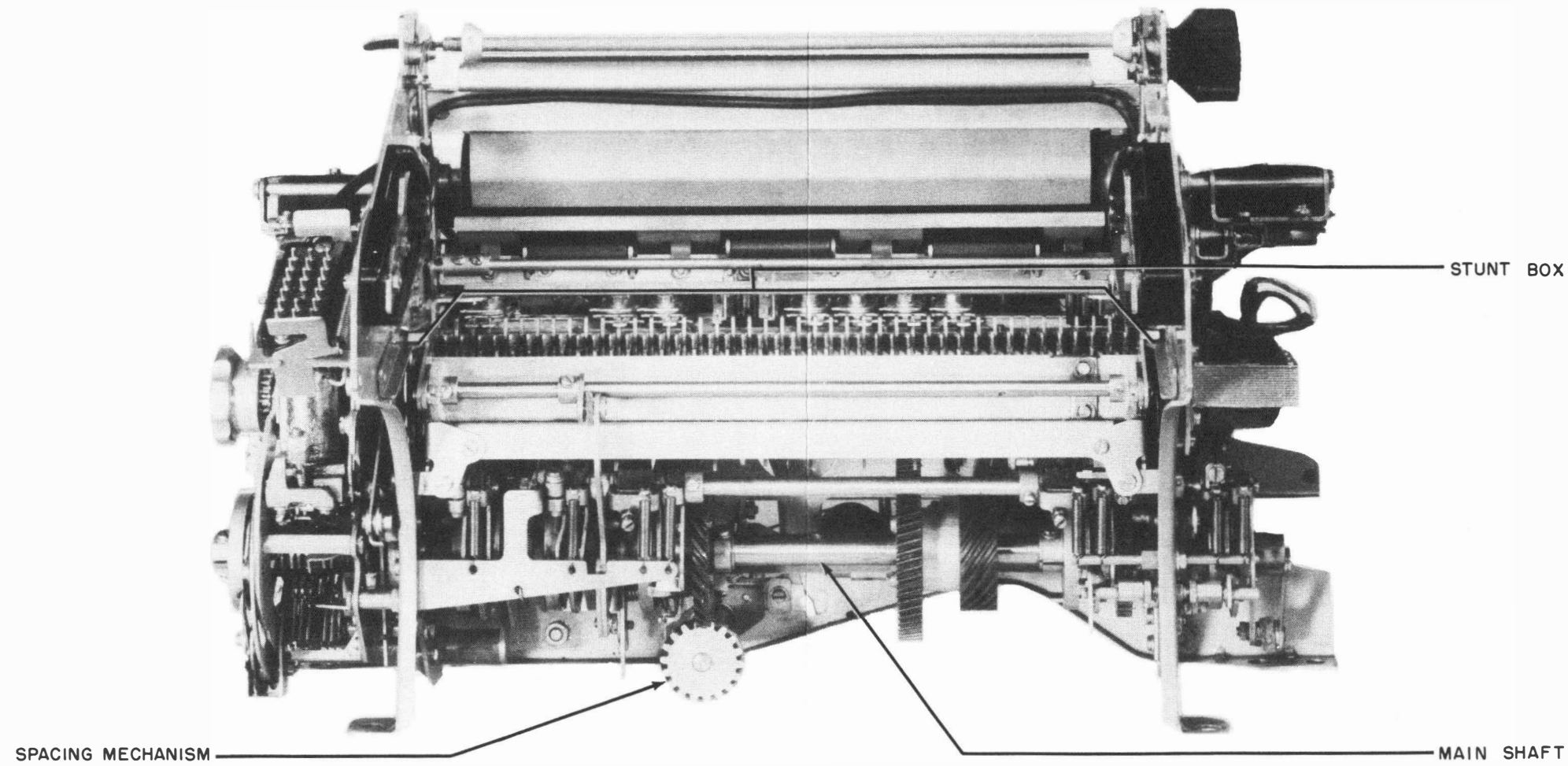

Figure 1-4. Typing Unit, Rear View

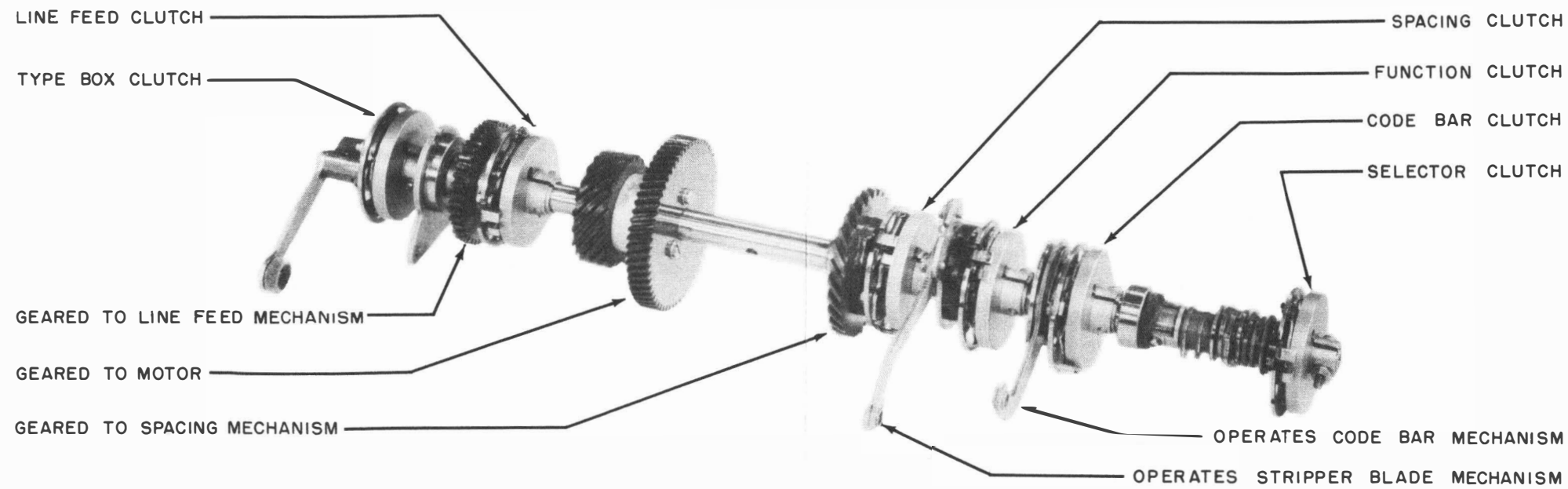

Figure 1-5. Typing Unit Main Shaft

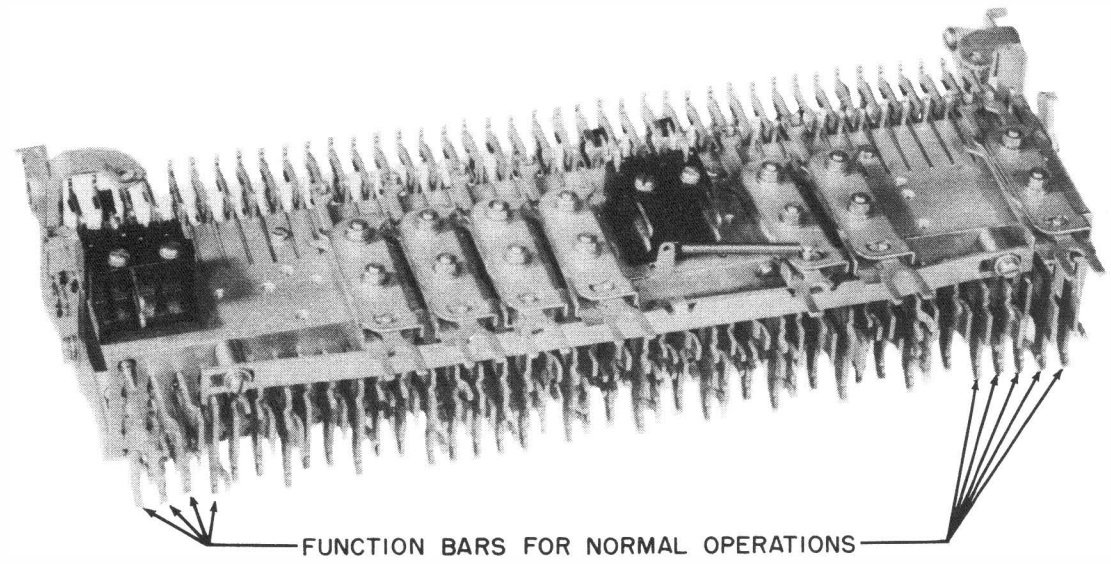

Figure 1-6. Typing Unit Stunt Box

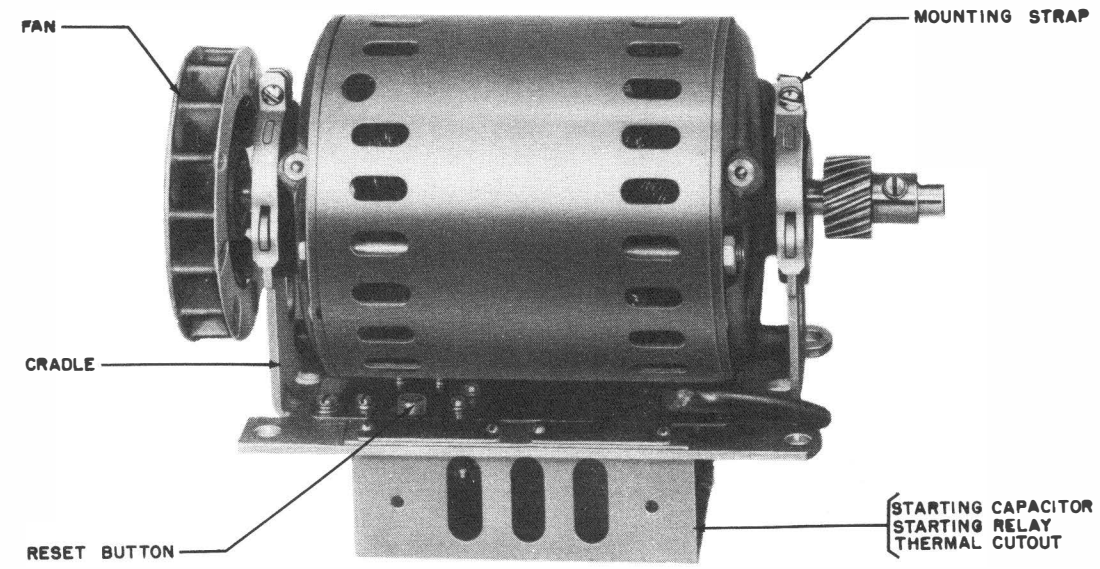

Figure 1-7. Synchronous Motor Unit

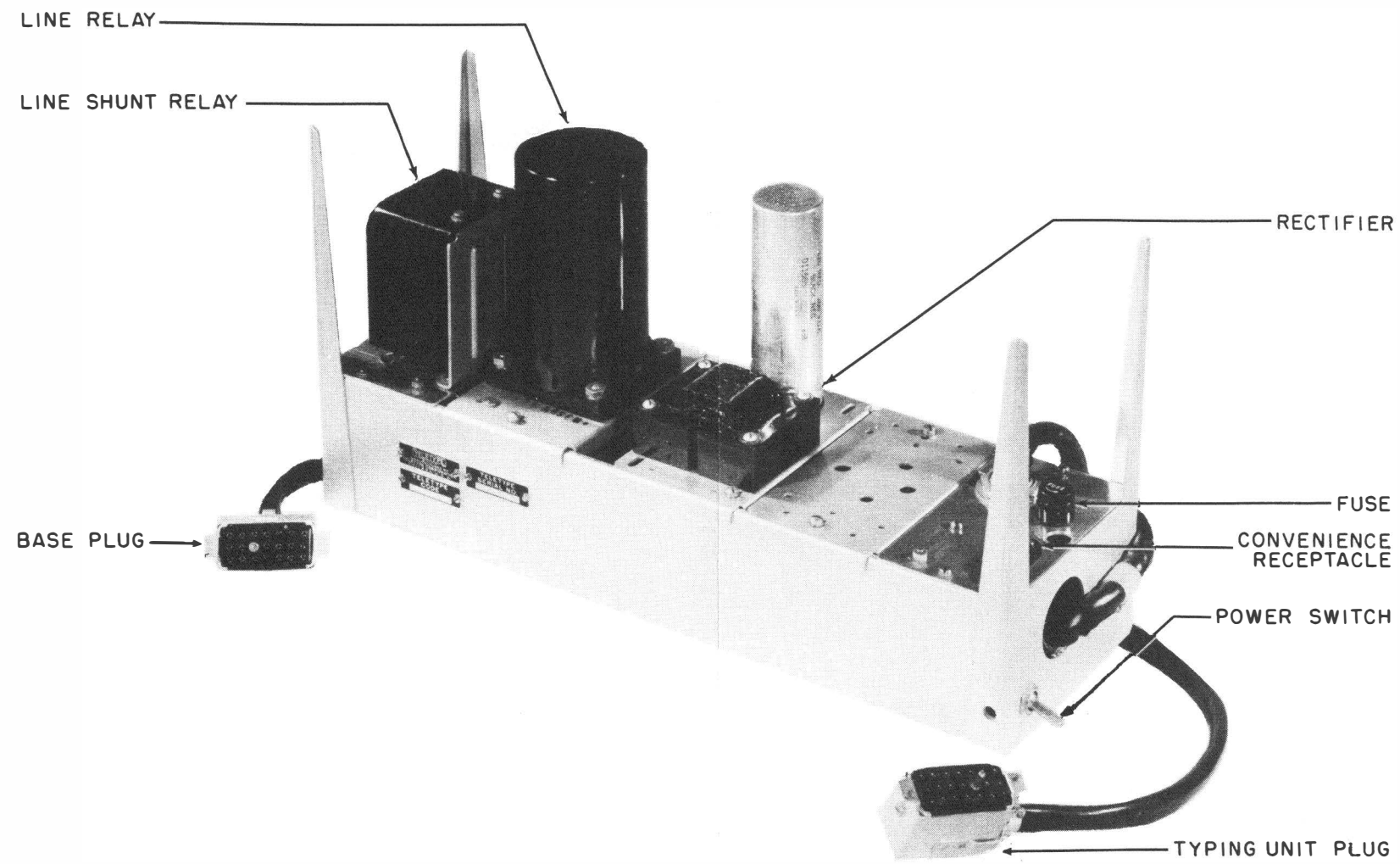

Figure 1-8. Electrical Service Unit

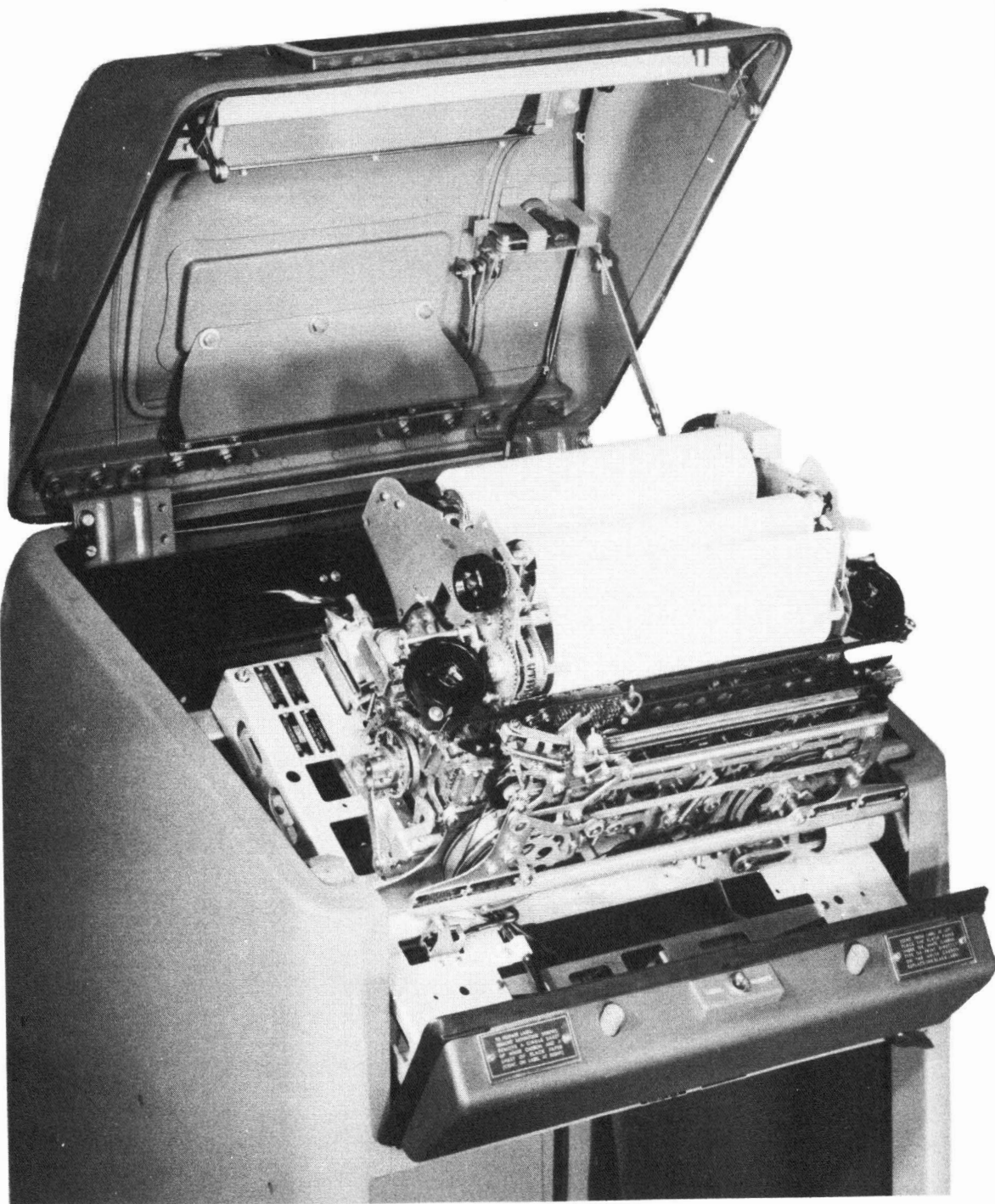

Figure 1-9. Tilting Arrangement

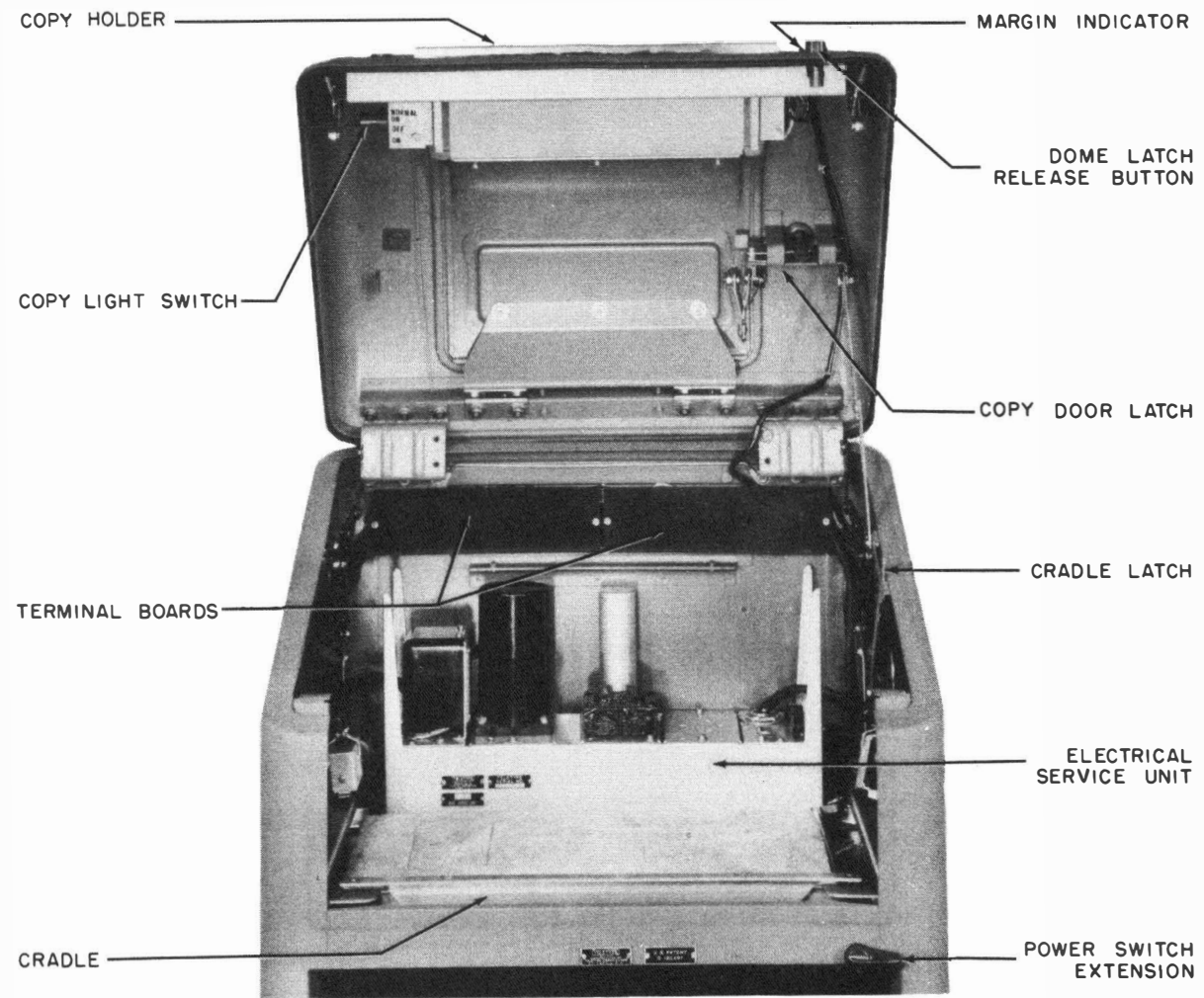

Figure 1-10. Cabinet, With Electrical Service Unit

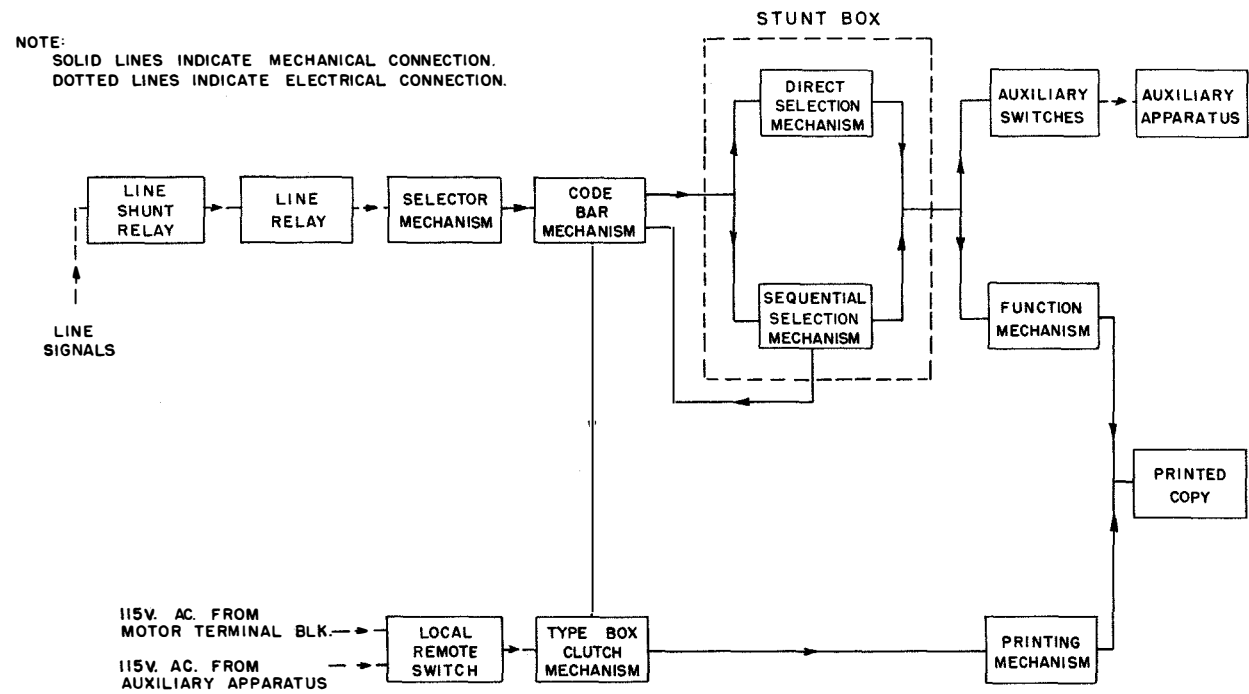
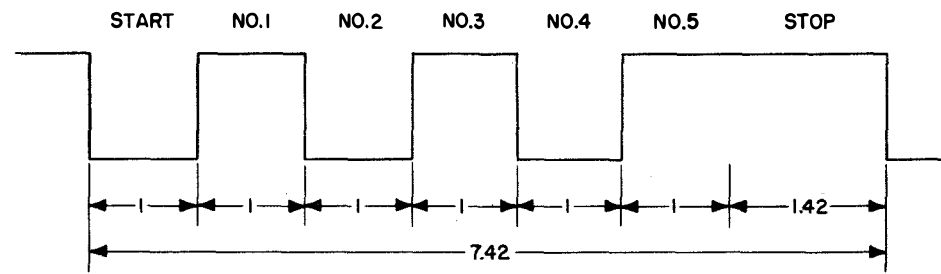

Figure 2-1. Functional Block Diagram of Typing Unit



| | | | | | | | | | | | | | | | | | | | | | | | | | | | | | | | | |
|-----------------------------------|---|---|---|---|---|---|---|---|---|---|---|---|---|---|---|---|------|---|---|---|---|---|---|---|---------------|---------|---------------|---------|-------|------|------|---|
| FIGURES | † | 0 | 1 | 2 | 3 | 4 | 5 | 6 | 7 | 8 | 9 | 0 | 1 | 2 | 3 | 4 | BELL | 5 | 7 | 0 | 2 | / | 6 | + | BLANK LETTERS | FIGURES | SPACE | C.R. | L.F. | | | |
| LETTERS | A | B | C | D | E | F | G | H | I | J | K | L | M | N | O | P | Q | R | S | T | U | V | W | X | Y | Z | BLANK LETTERS | FIGURES | SPACE | C.R. | L.F. | |
| NUMBERS INDICATE MARKING IMPULSES | 1 | 1 | 1 | 1 | 1 | 1 | 1 | 1 | 1 | 1 | 1 | 1 | 1 | 1 | 1 | 1 | 1 | 1 | 1 | 1 | 1 | 1 | 1 | 1 | 1 | 1 | 1 | 1 | 1 | 1 | 1 | 1 |
| | 2 | 2 | | | | 2 | 2 | 2 | 2 | | | | | | 2 | 2 | 2 | | | | 2 | 2 | | | | | 2 | 2 | | | 2 | |
| | | | 3 | | 3 | 3 | 3 | 3 | 3 | 3 | 3 | 3 | 3 | 3 | 3 | 3 | 3 | 3 | 3 | 3 | 3 | 3 | 3 | 3 | 3 | 3 | 3 | 3 | 3 | 3 | 3 | 3 |
| | 4 | 4 | 4 | 4 | 4 | 4 | 4 | 4 | 4 | 4 | 4 | 4 | 4 | 4 | 4 | 4 | 4 | 4 | 4 | 4 | 4 | 4 | 4 | 4 | 4 | 4 | 4 | 4 | 4 | 4 | 4 | 4 |
| | 5 | | | | 5 | 5 | | | | 5 | 5 | 5 | 5 | 5 | 5 | 5 | 5 | 5 | 5 | 5 | 5 | 5 | 5 | 5 | 5 | 5 | 5 | 5 | 5 | 5 | 5 | 5 |

Figure 2-3. Signal Code

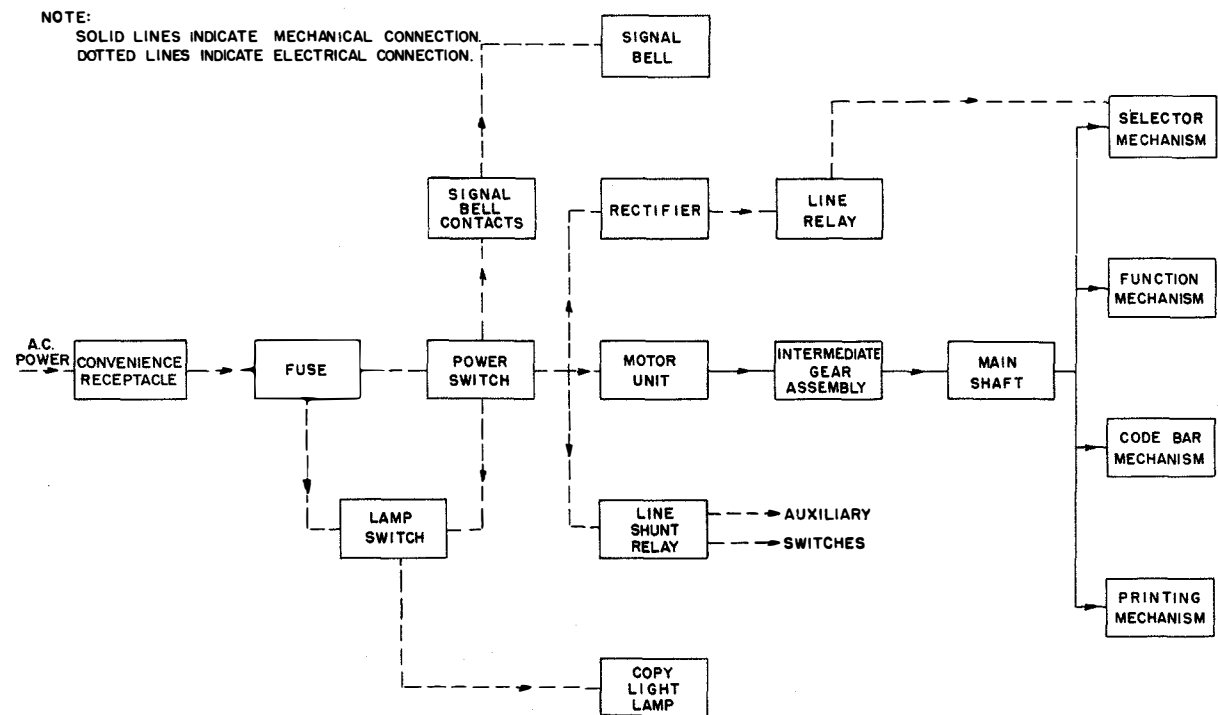

Figure 2-2. Functional Block Diagram of Electrical and Mechanical Power Flow

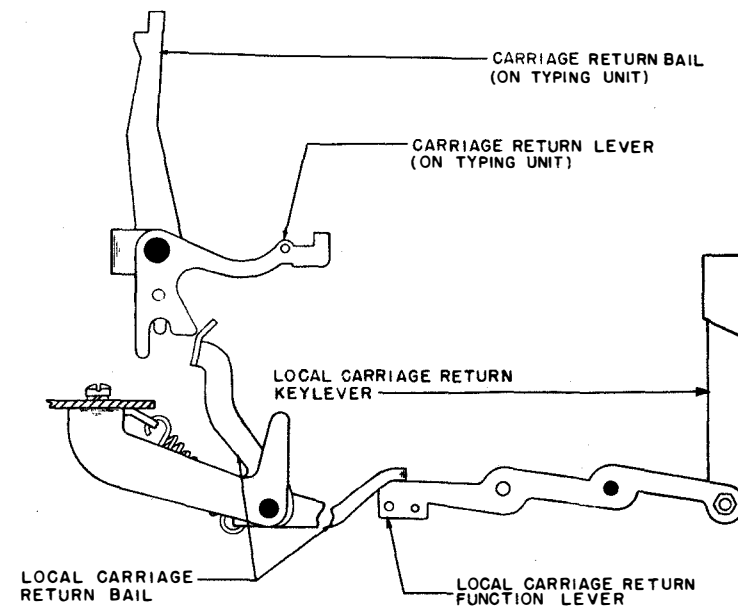

Figure 2-4.

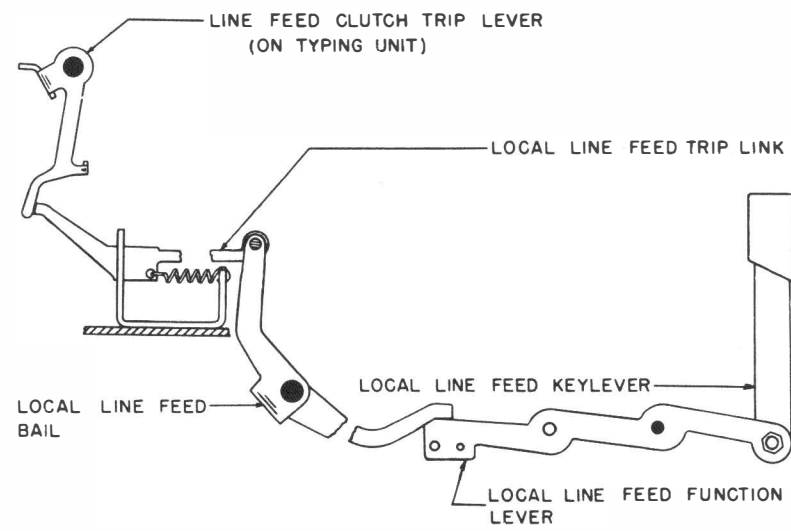

Figure 2-5.

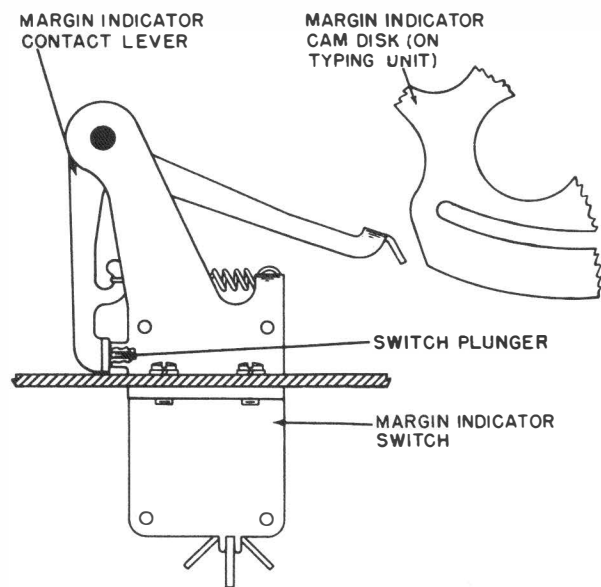

Figure 2-6.

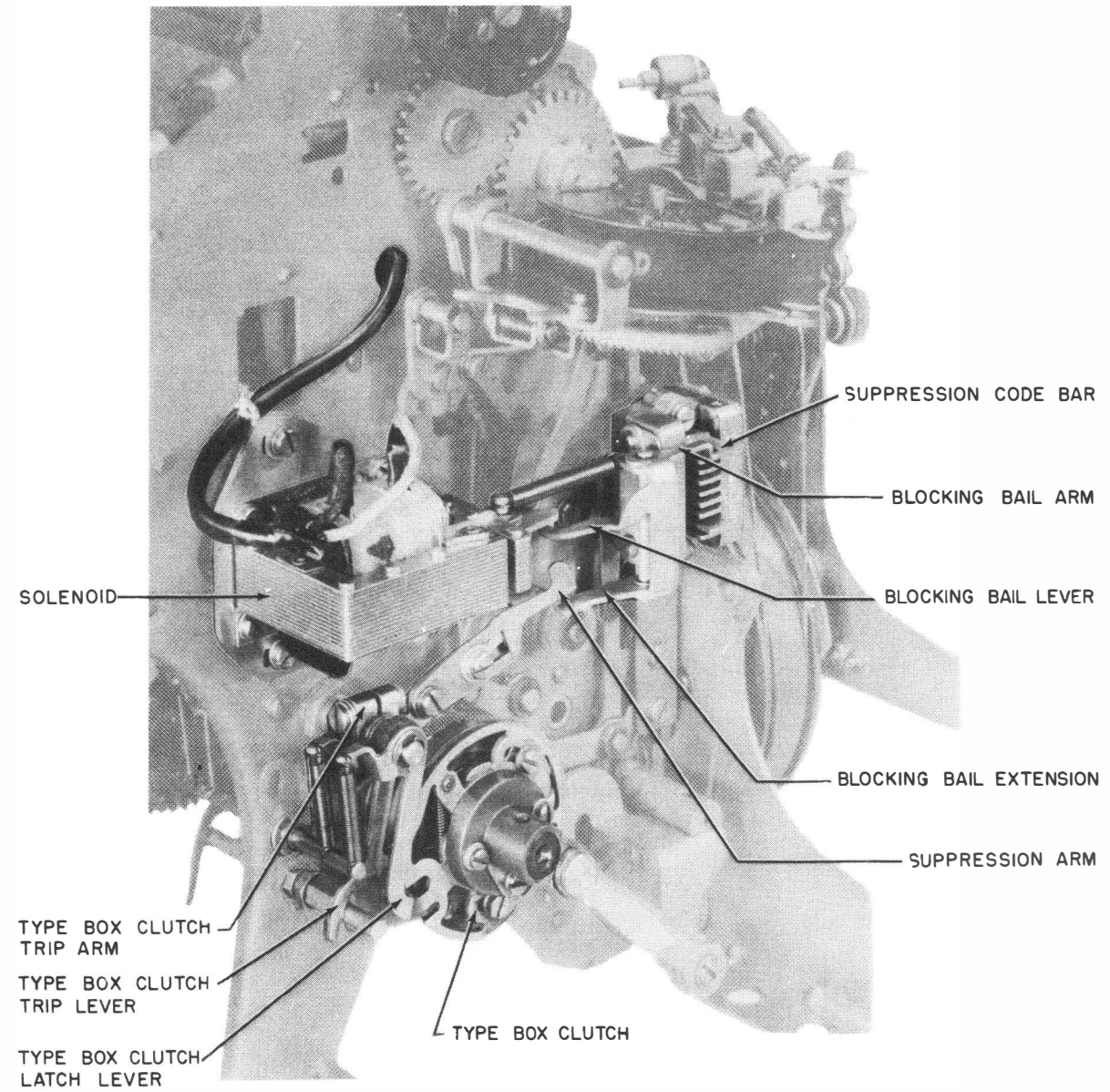

Figure 2-7.

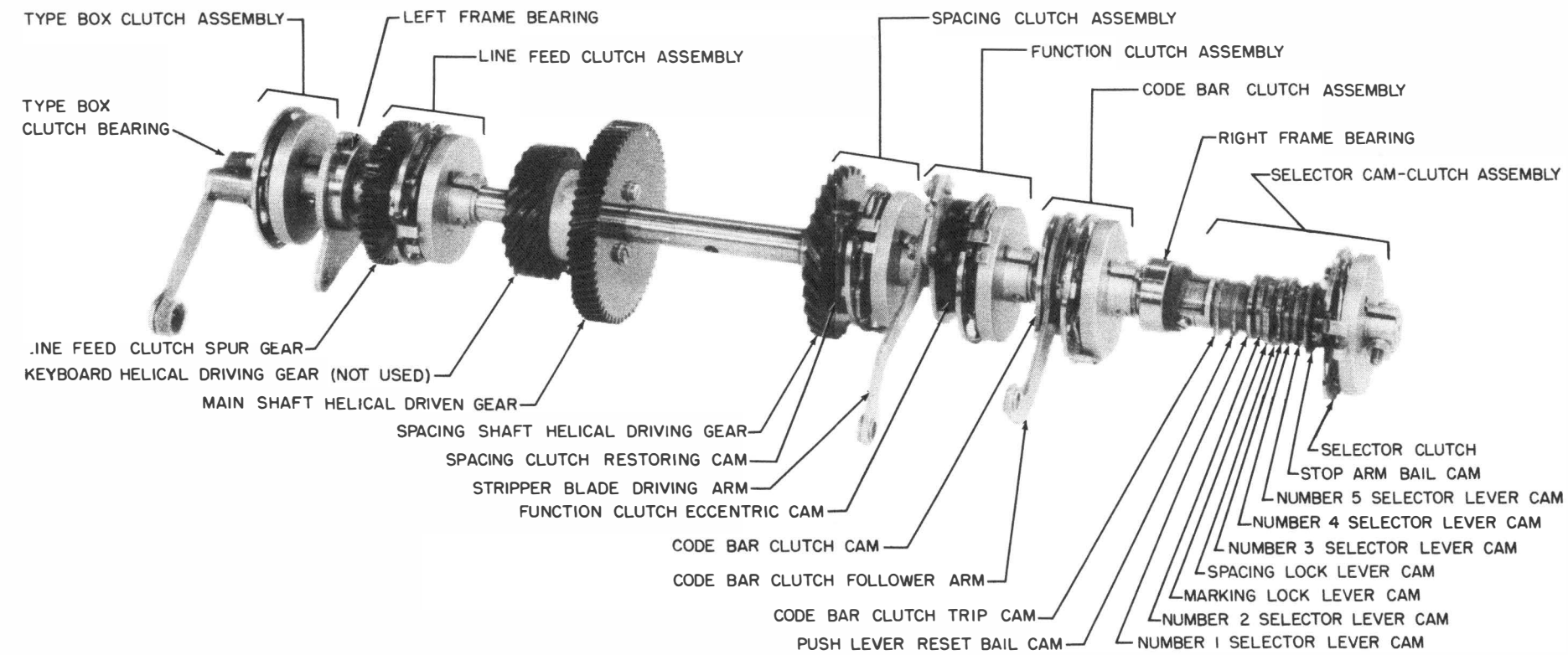

Figure 2-8. Typing Unit Main Shaft

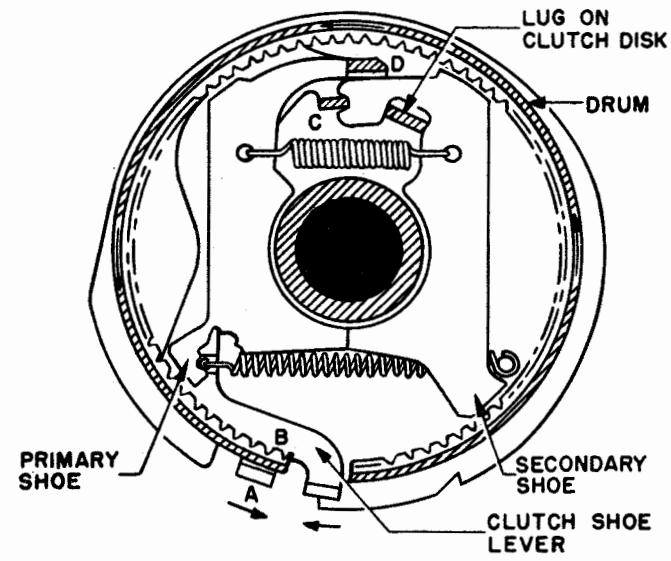

Figure 2-9. Clutch, Disengaged

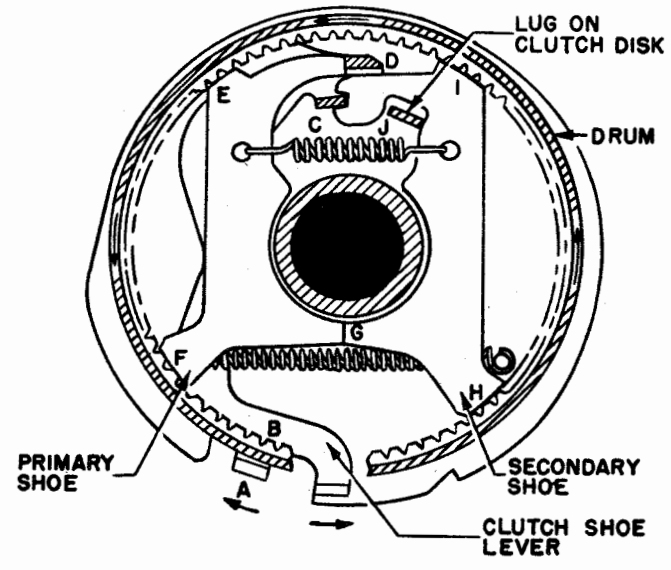

Figure 2-10. Clutch, Engaged

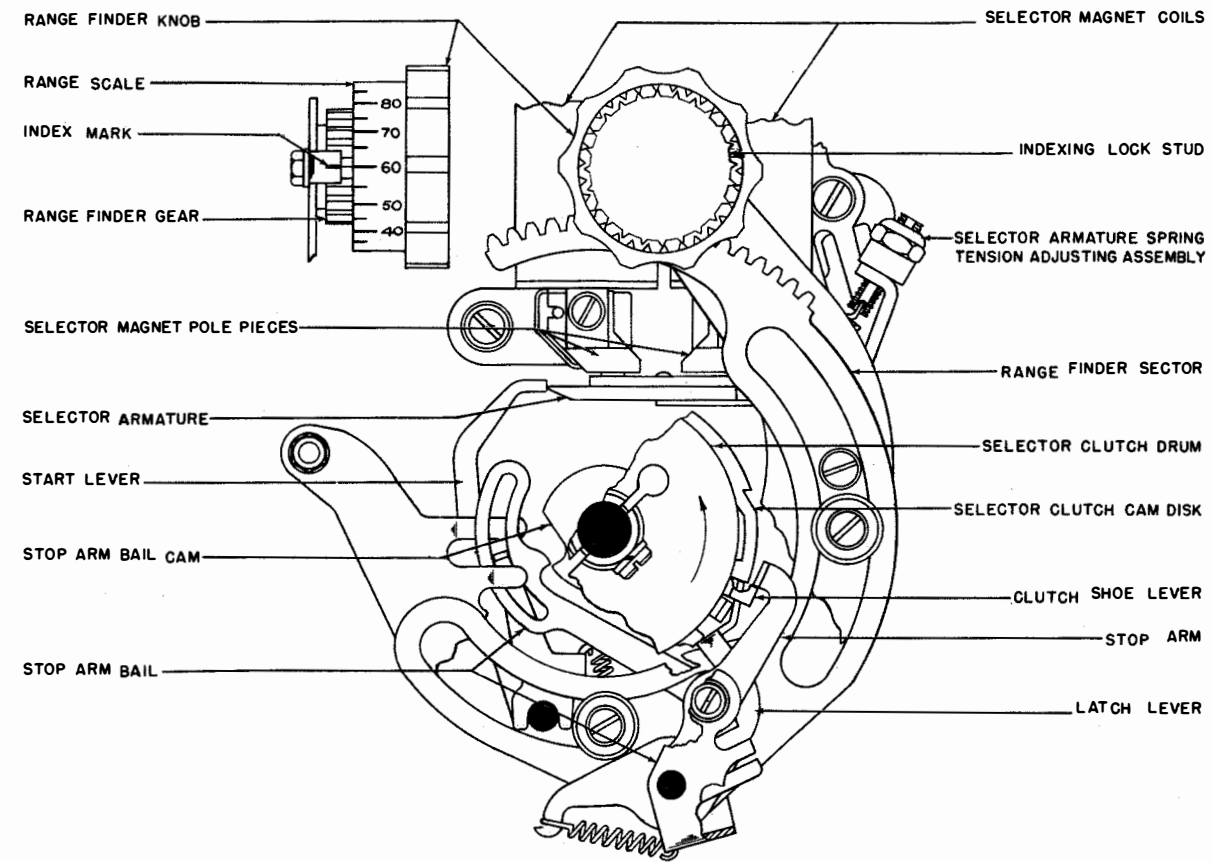

Figure 2-11.

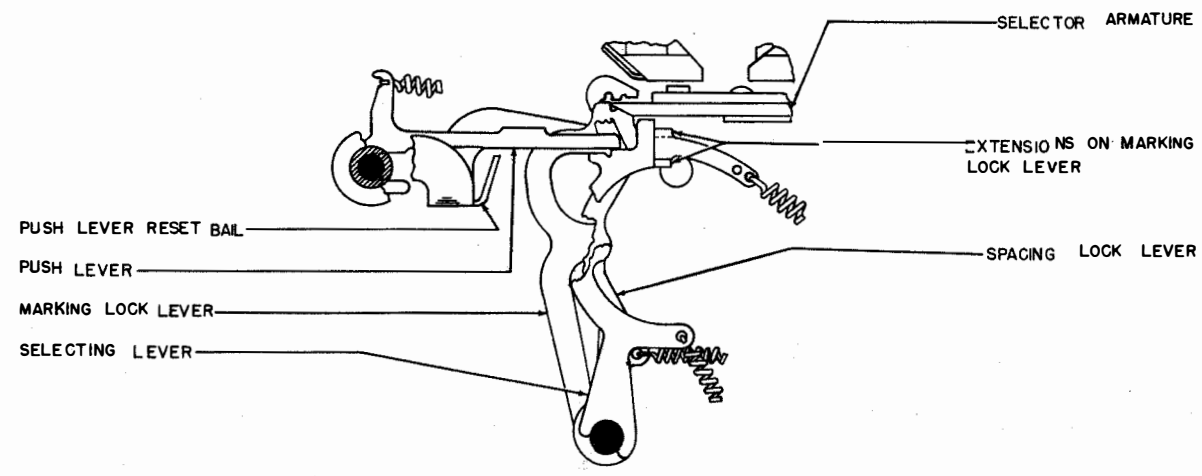

Figure 2-12.

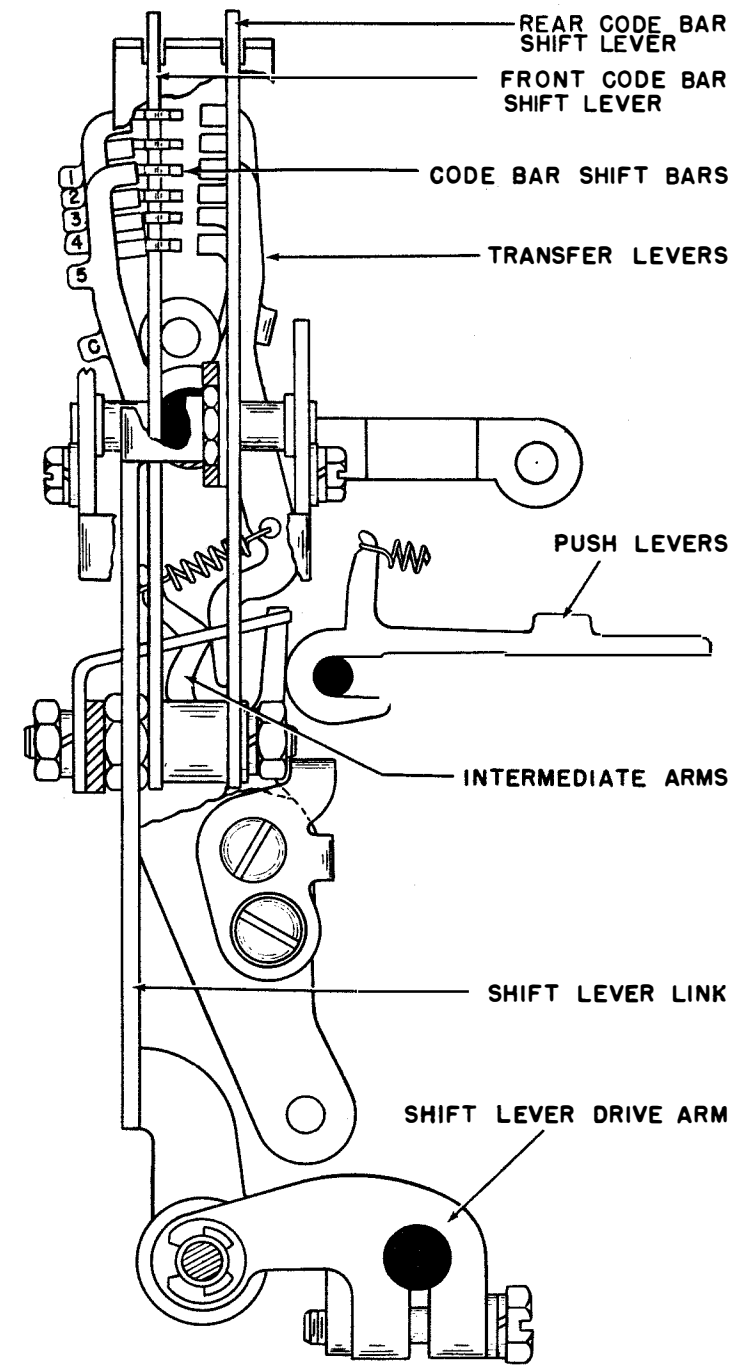

Figure 2-13.

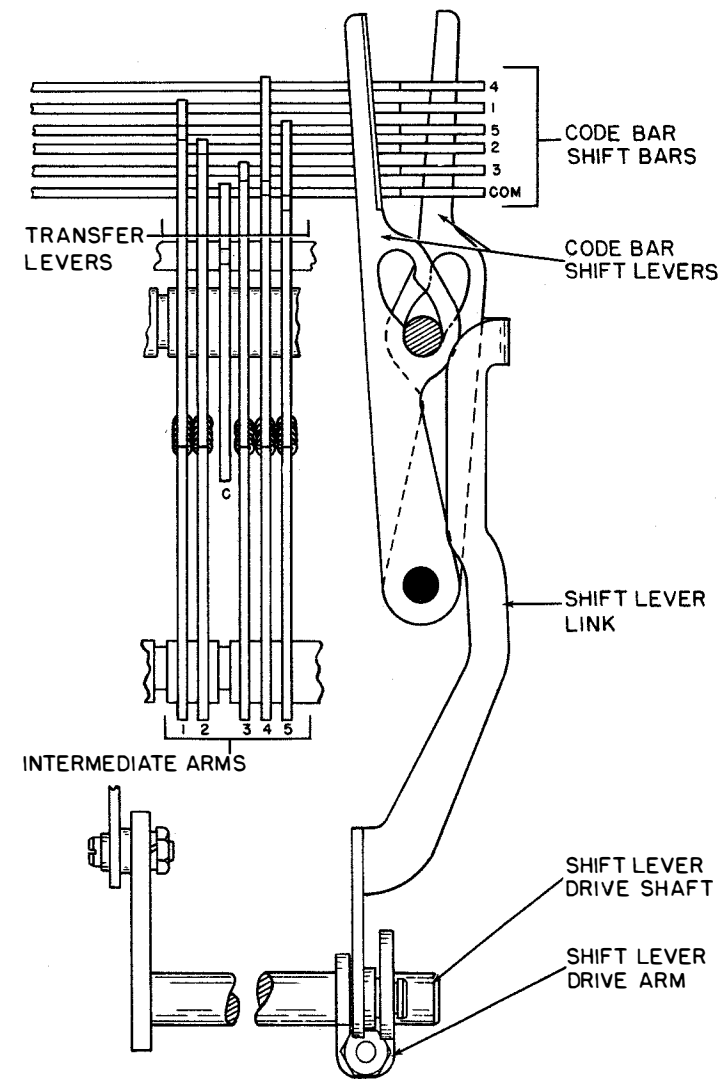

Figure 2-14.

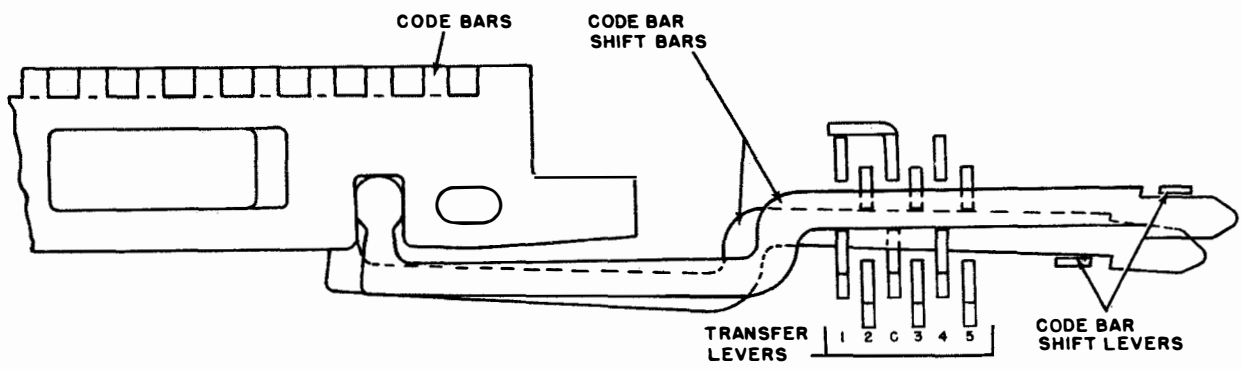

Figure 2-15.

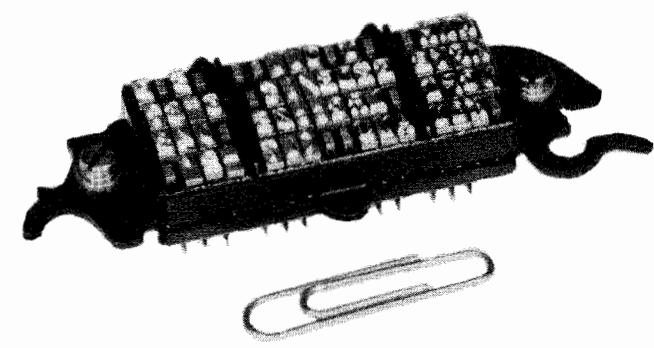

Figure 2-17.

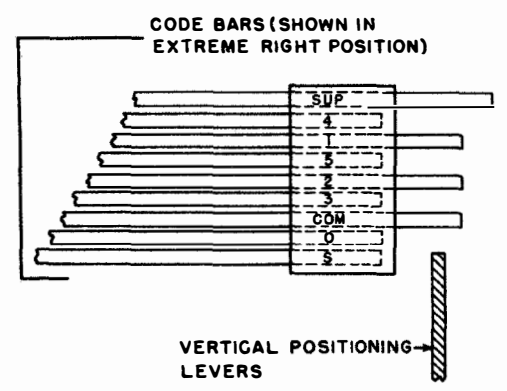

Figure 2-16.

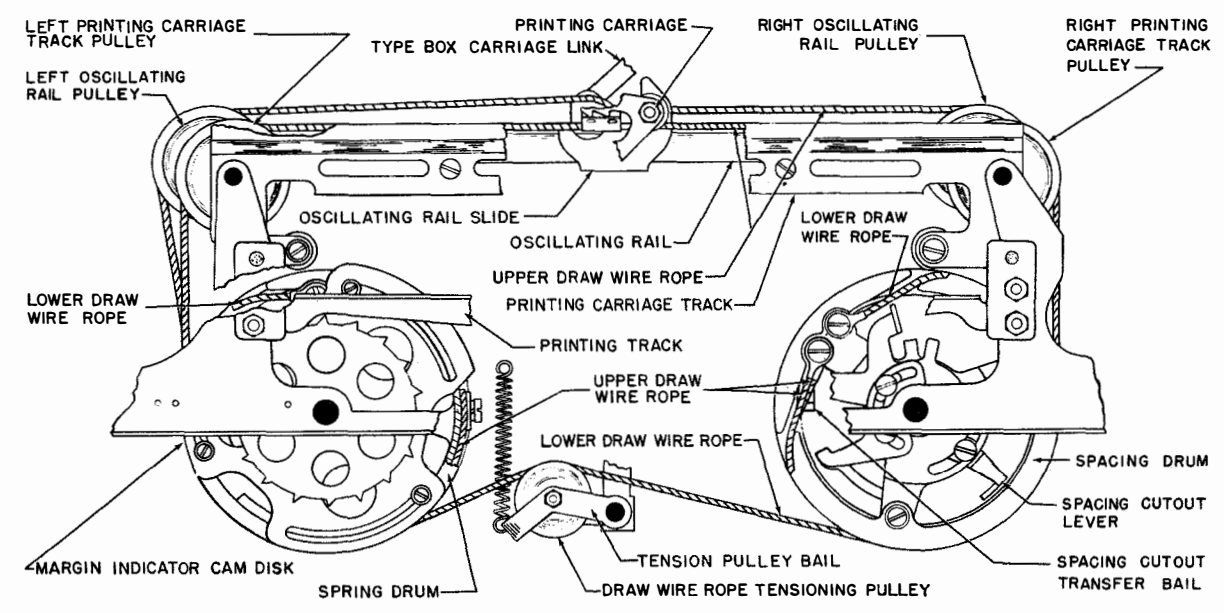

Figure 2-18. Draw Wire Rope Mechanism

| | | LETTERS | | | | FIGURES | | | | | | | | | | | | | |
|---------------------|--|---------------------|---------------------|---------------------|---------------------|---------------------|---------------------|---------------------|---------------------|---------------------|---------------------|---------------------|---------------------|---------------------|---------------------|---------------------|---------------------|---------------|--|
| | | LEFT | | RIGHT | | LEFT | | RIGHT | | | | | | | | | | | |
| | | 4 8 5 MARKING | 4 5 MARKING | 4 5 MARKING | 4 8 5 MARKING | 4 8 5 MARKING | 4 5 MARKING | 4 8 5 MARKING | 4 8 5 MARKING | | | | | | | | | | |
| TOP ROW | | M | N | H | SPACE | BLANK | T | C. R. | O | BLANK | 5 | C. R. | 9 | 1 8 2 SPACING | | | | | |
| 2 ND ROW | | X | F | Y | S | E | Z | D | B | / | → | 6 | BELL | 3 | + | ↗ | ⊕ | MARKING | |
| 3 RD ROW | | V | C | P | I | L. F. | L | R | G | ⊙ | ○ | ∅ | 8 | BLANK | ↘ | 4 | ↖ | MARKING | |
| BOTTOM ROW | | LETTERS | K | Q | U | A | W | J | FIGURES | LETTERS | ← | 1 | 7 | ↑ | 2 | ↙ | FIGURES | 1 8 2 MARKING | |
| | | 3 MARKING | | | | 3 SPACING | | | | | | 3 SPACING | | | | | | | |
| | | 4 TH ROW | 3 RD ROW | 2 ND ROW | 1 ST ROW | 1 ST ROW | 2 ND ROW | 3 RD ROW | 4 TH ROW | 4 TH ROW | 3 RD ROW | 2 ND ROW | 1 ST ROW | 1 ST ROW | 2 ND ROW | 3 RD ROW | 4 TH ROW | | |

Figure 2-19.

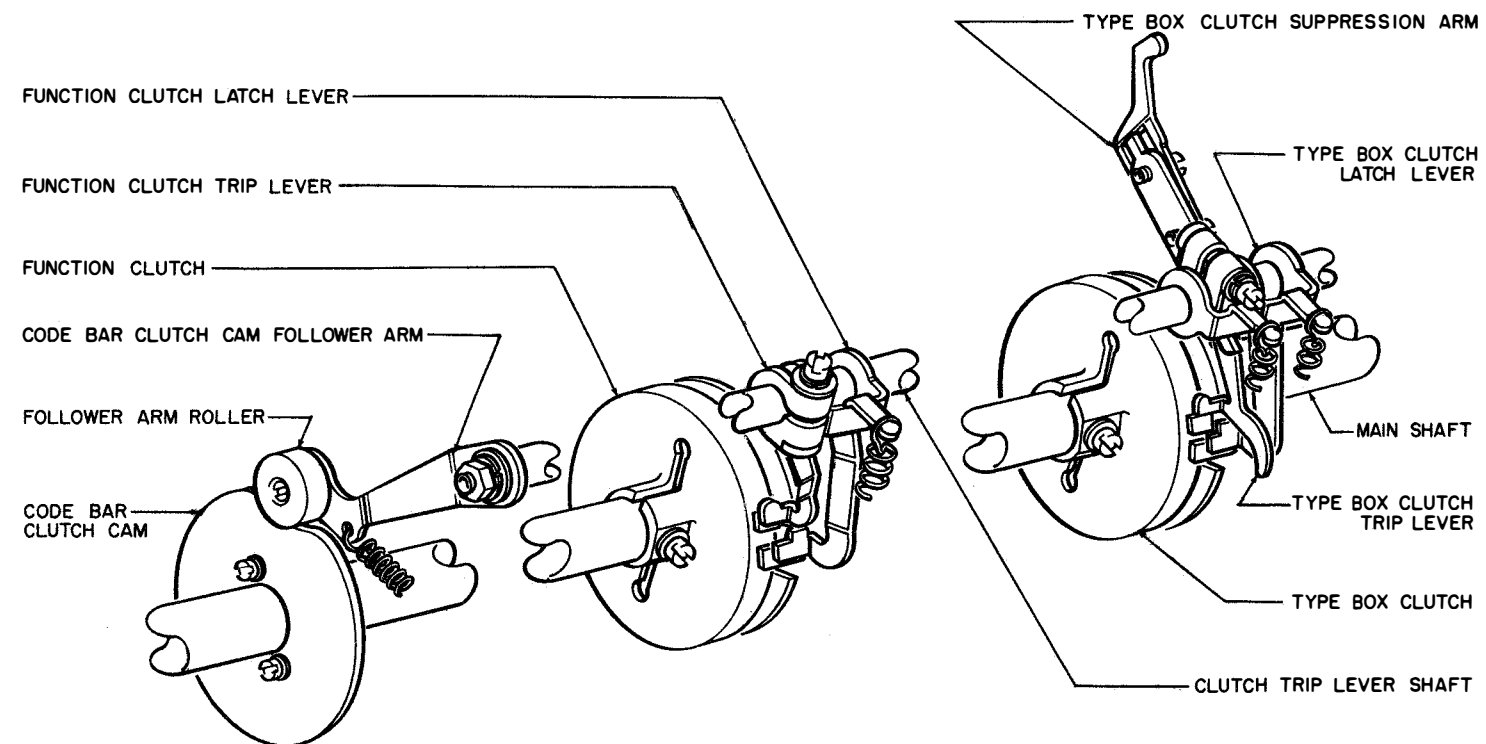

Figure 2-20. Trip Mechanism for Function and Type Box Clutches

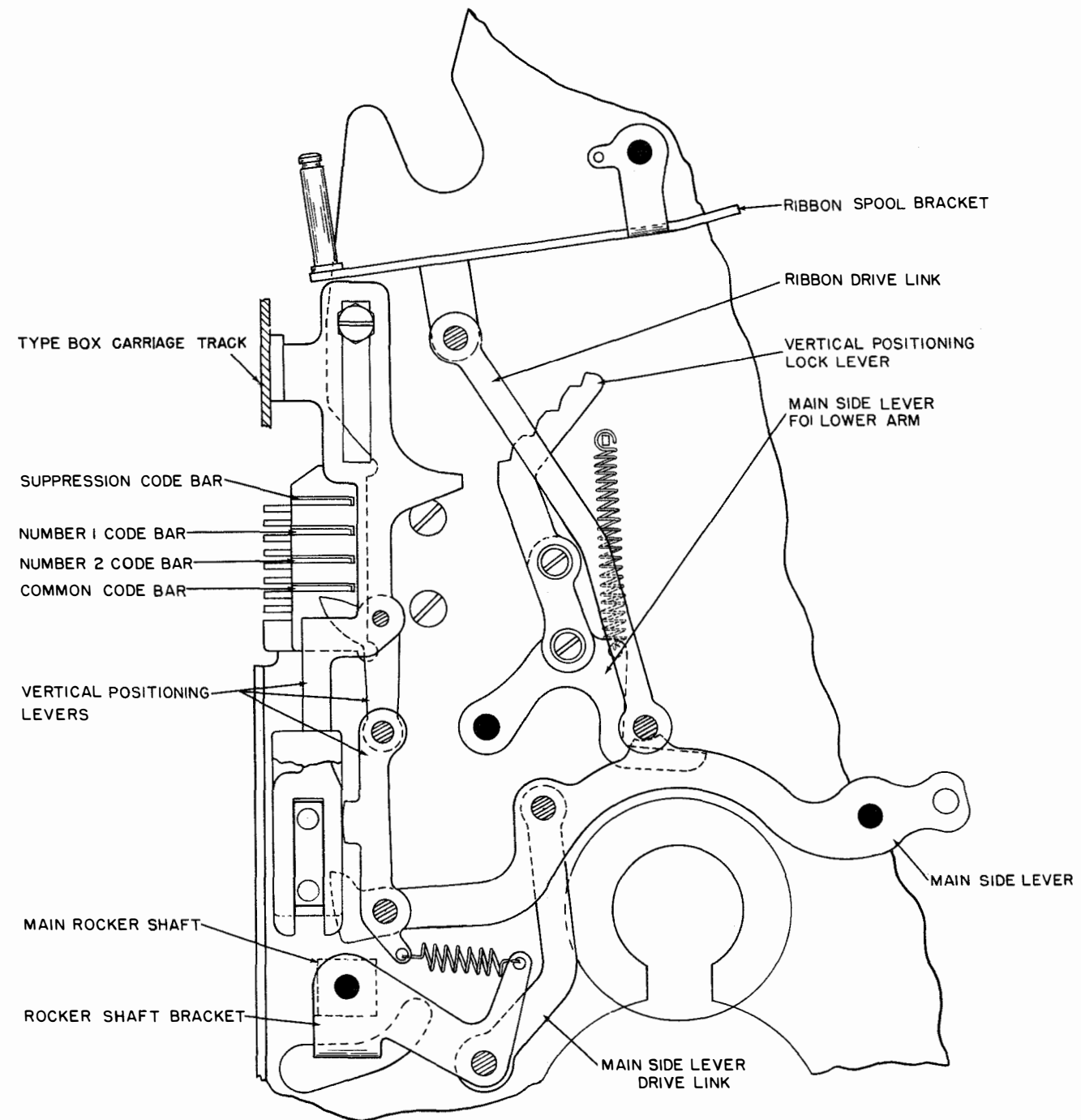

Figure 2-21. Right Side Mechanism

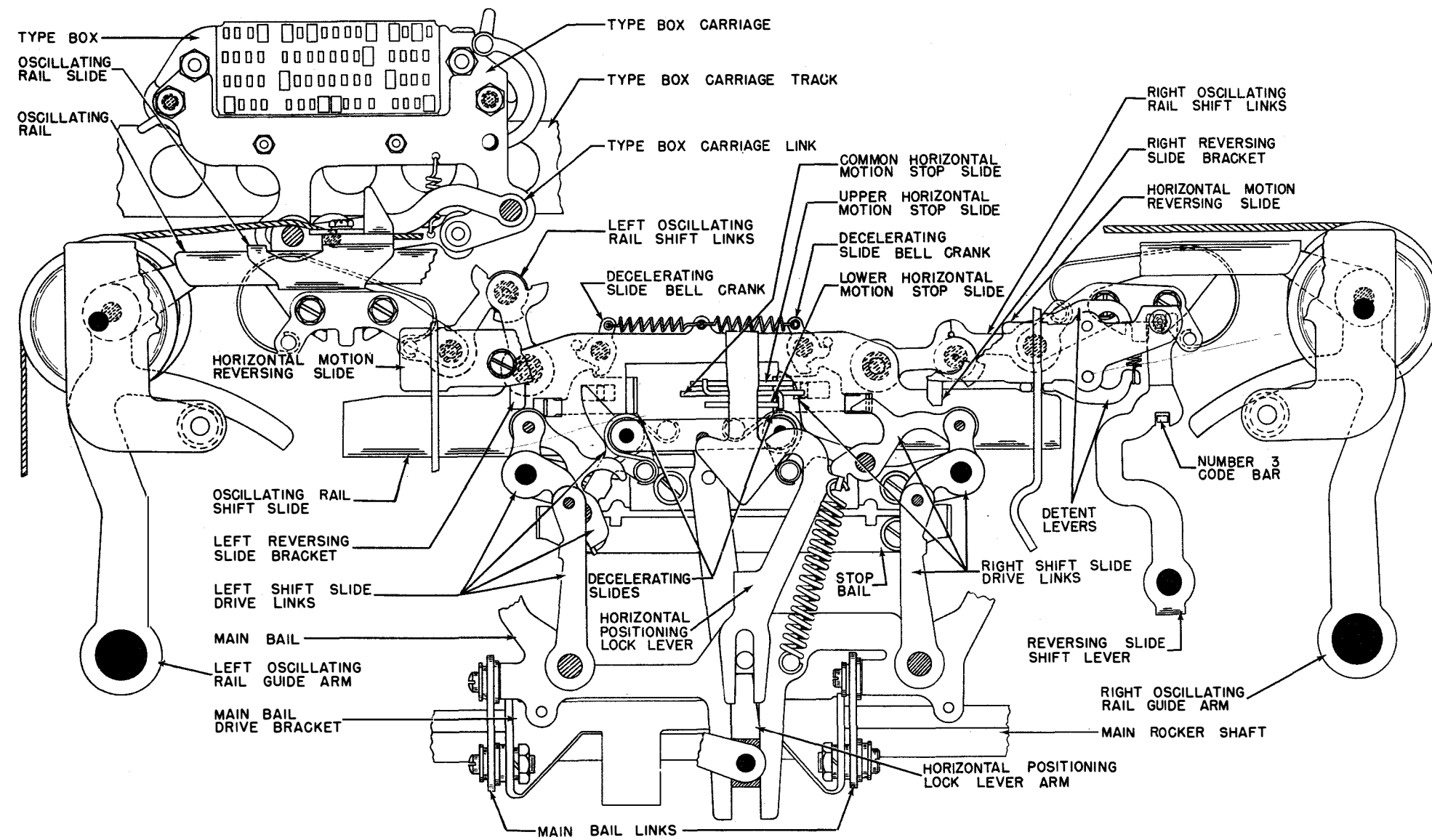

Figure 2-22. Front Plate Horizontal Positioning Mechanism

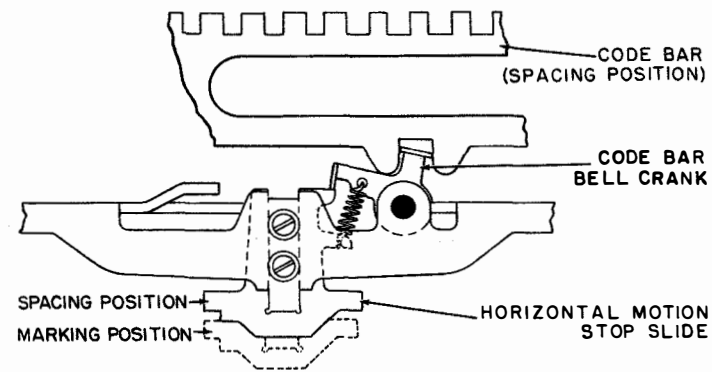

Figure 2-23.

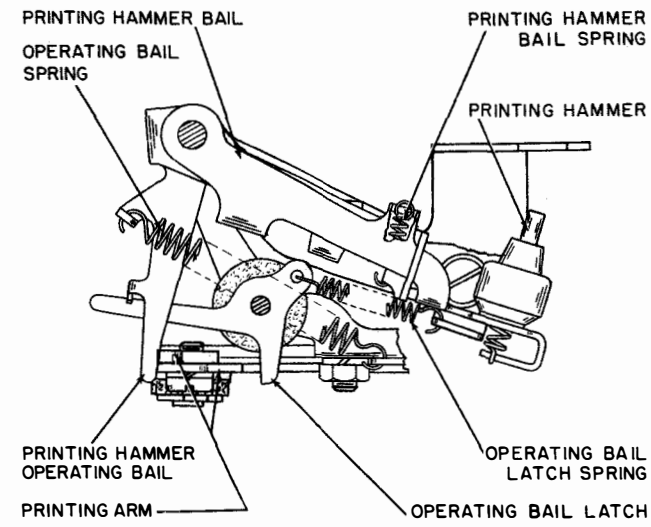

Figure 2-25.

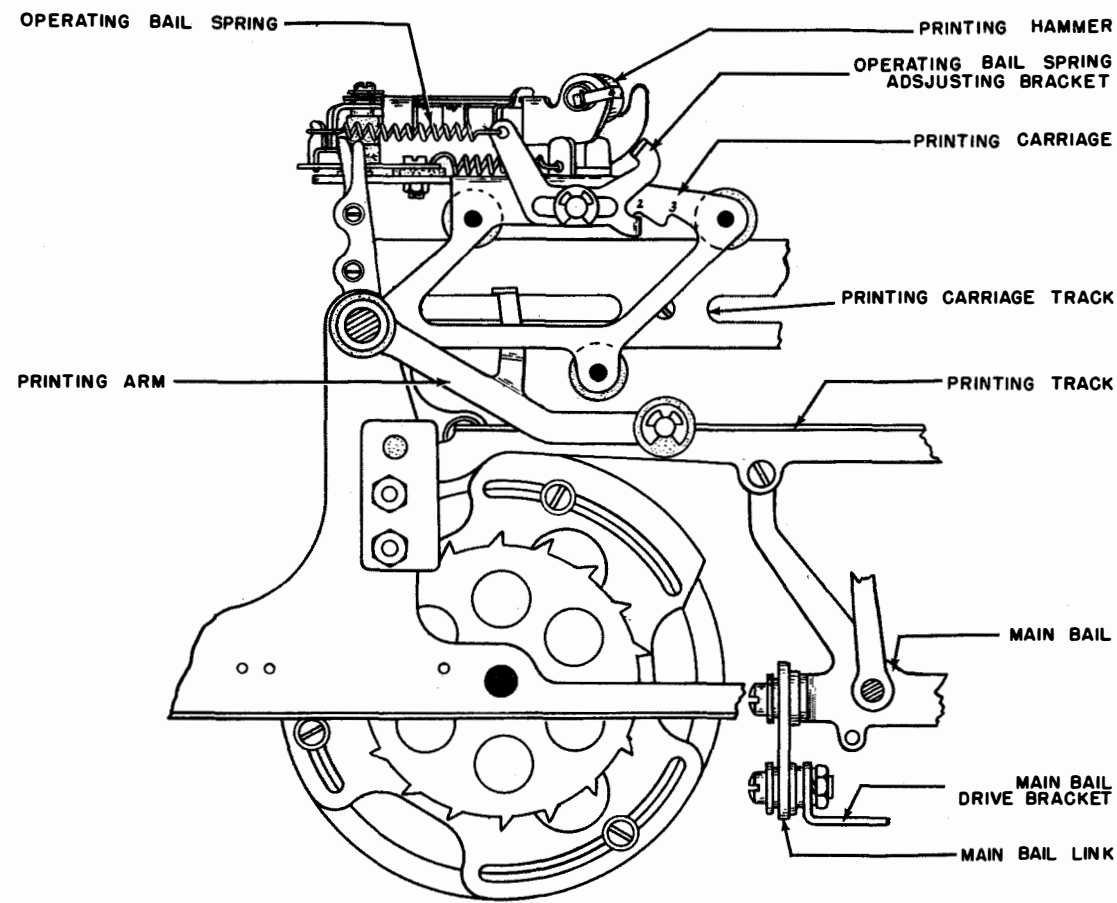

Figure 2-24.

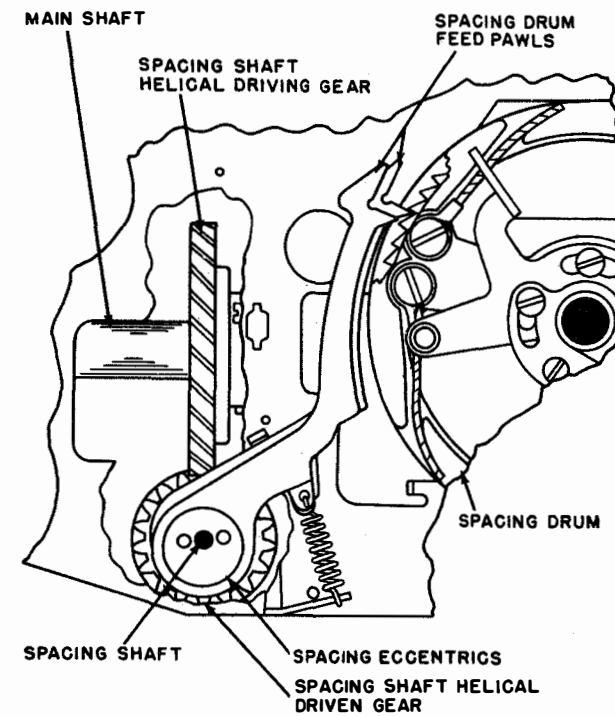

Figure 2-26.

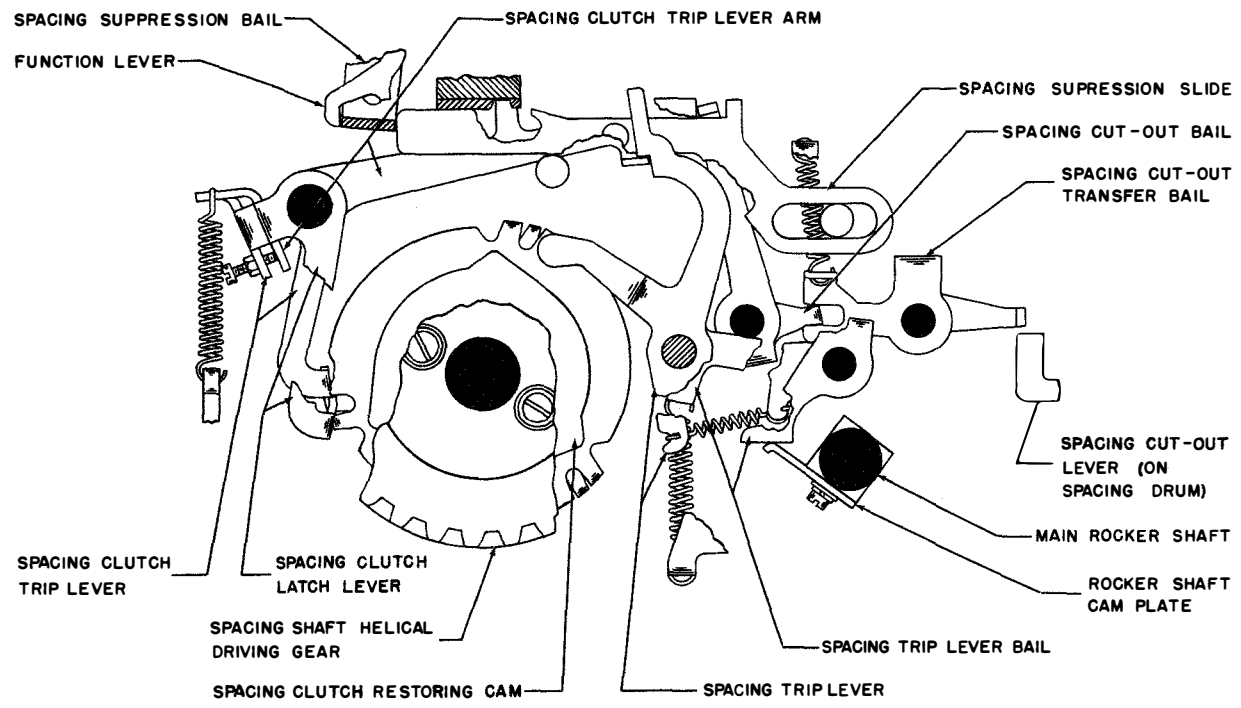

Figure 2-27.

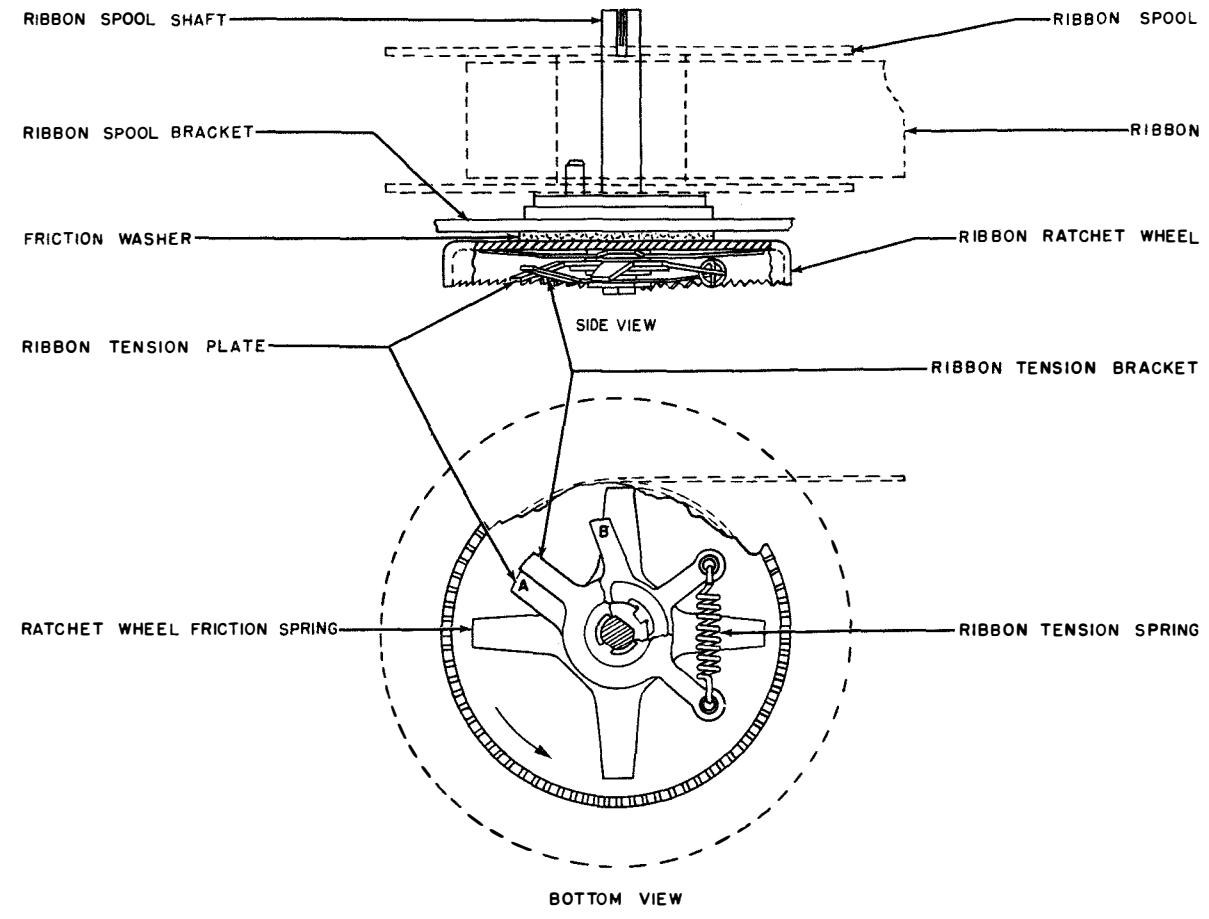

Figure 2-29.

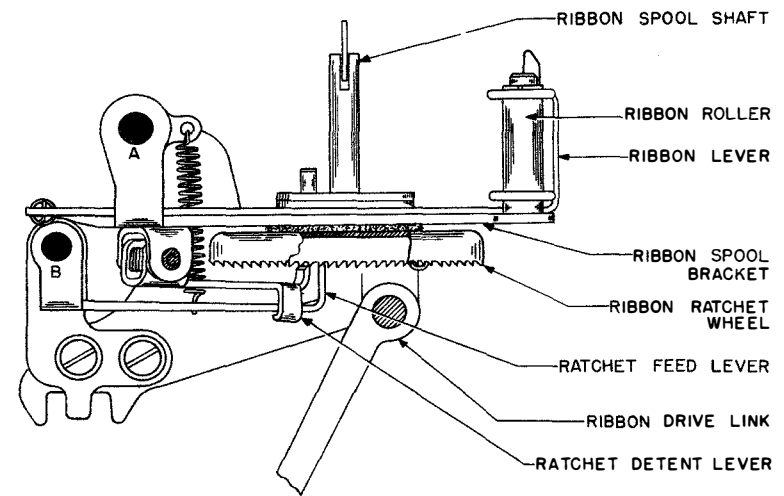

Figure 2-28.

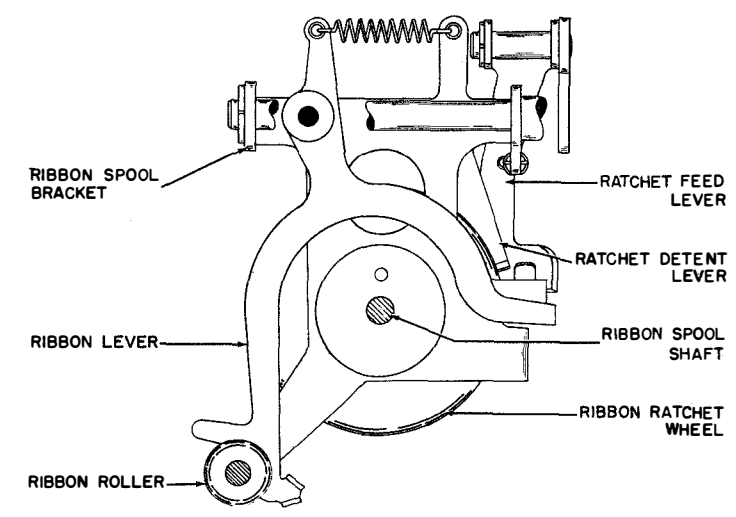

Figure 2-30.

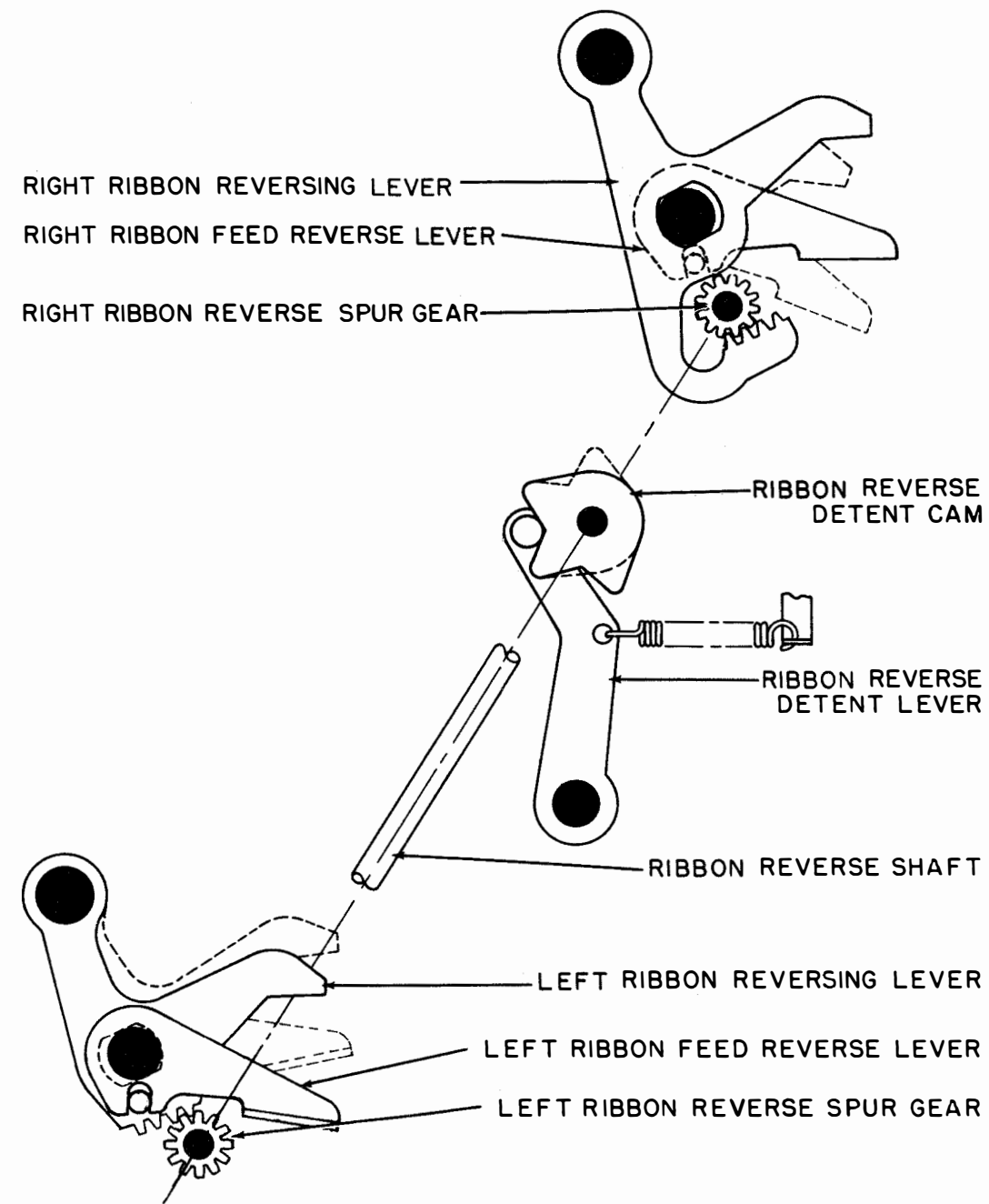

Figure 2-31.

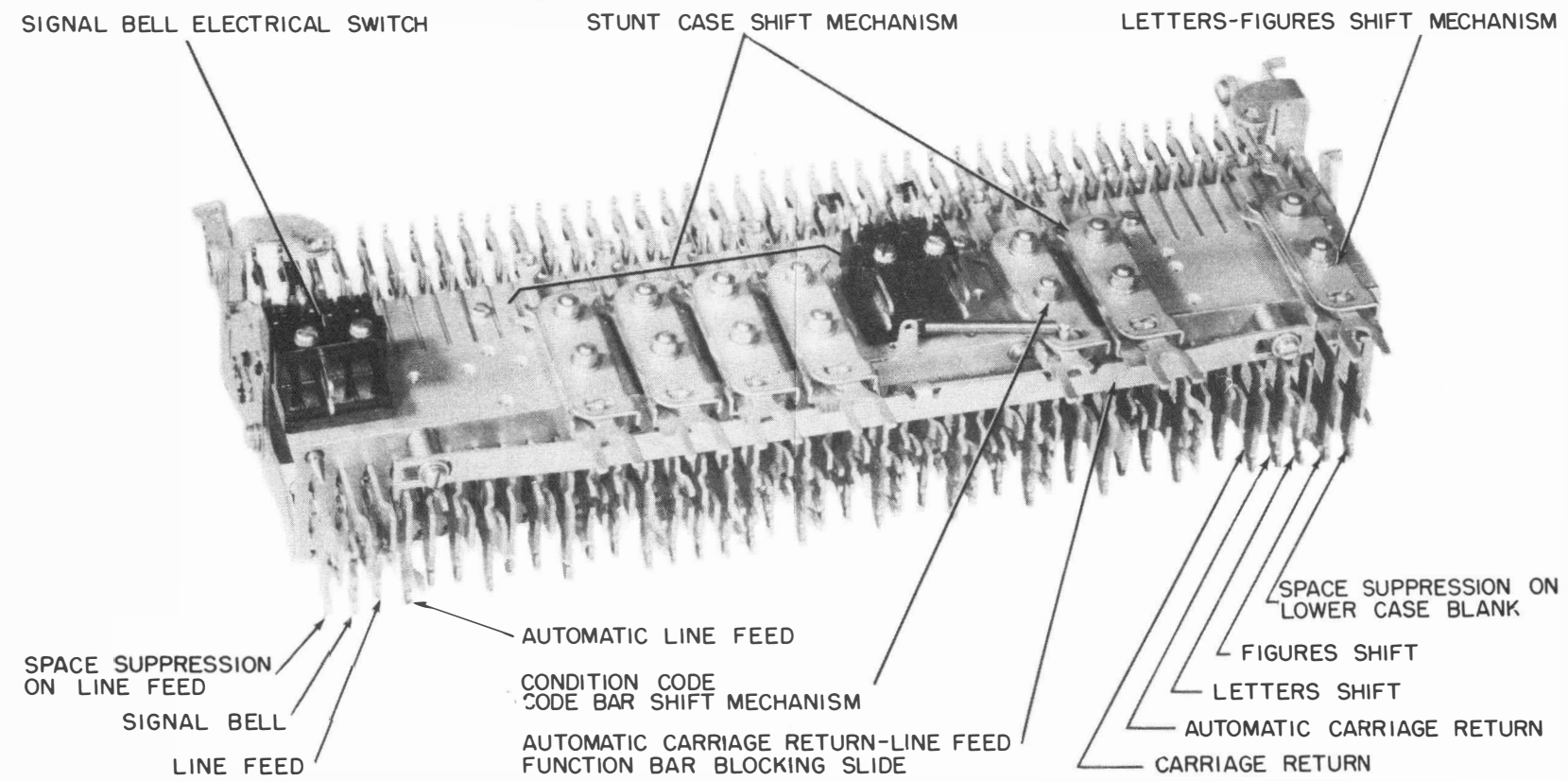

Figure 2-32. Stunt Box, Front View Showing Function Bars

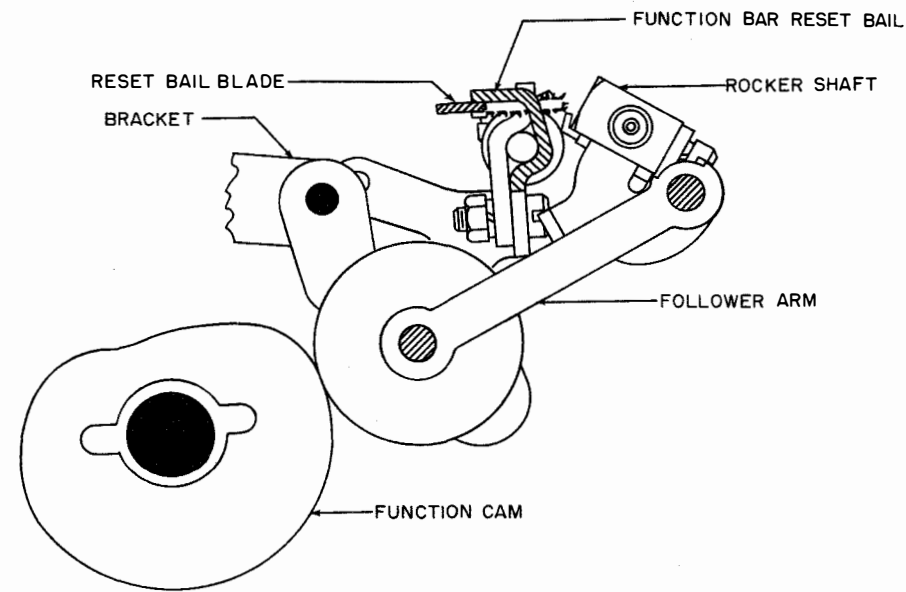

Figure 2-33. Function Reset Bail Driving Mechanism

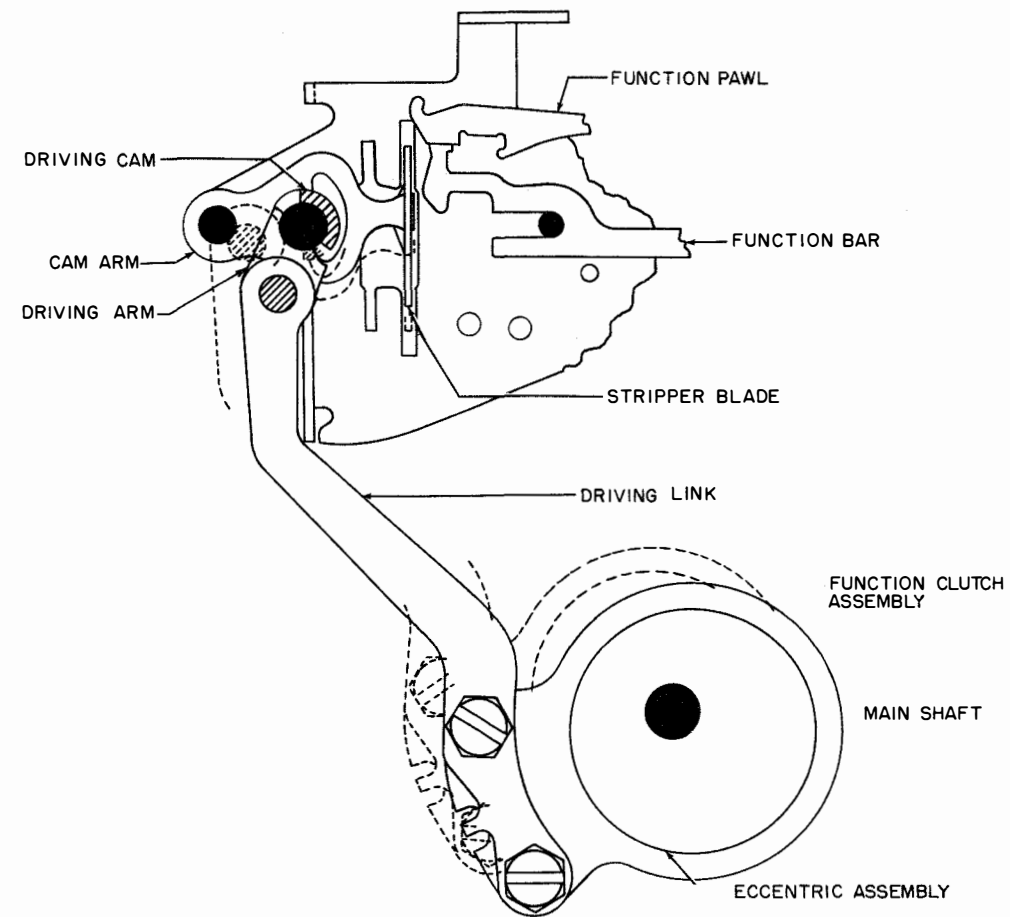

Figure 2-35. Stripper Blade Driving Mechanism

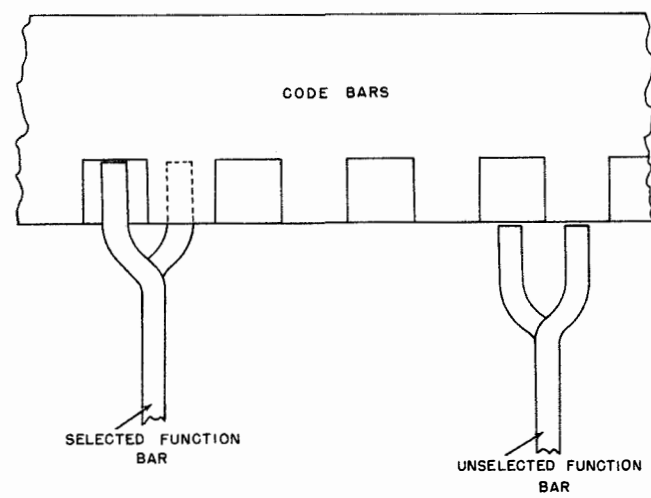

Figure 2-34.

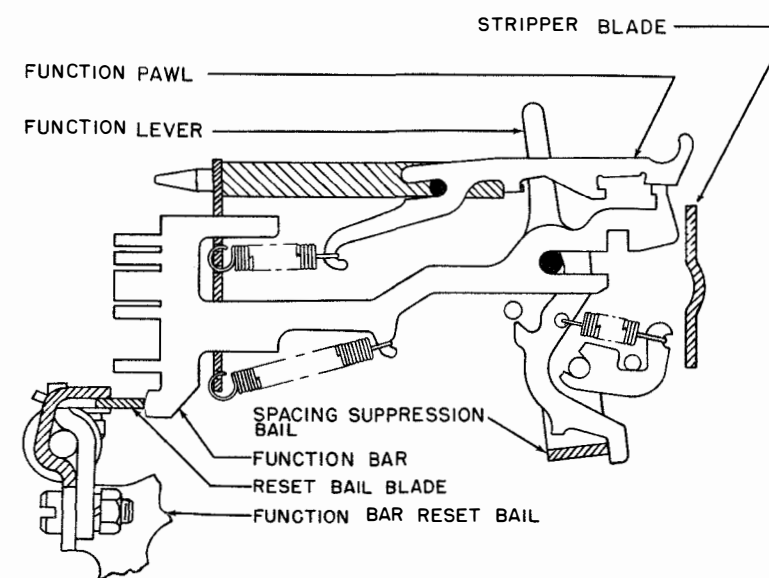

Figure 2-36.

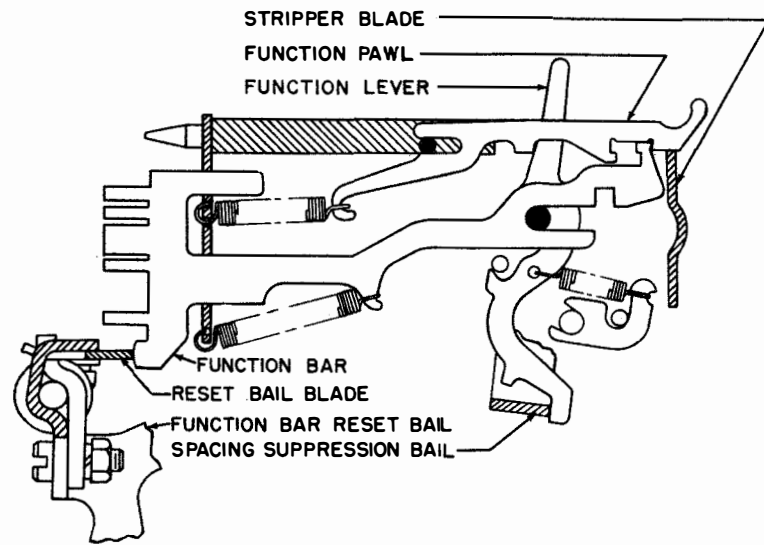

Figure 2-37.

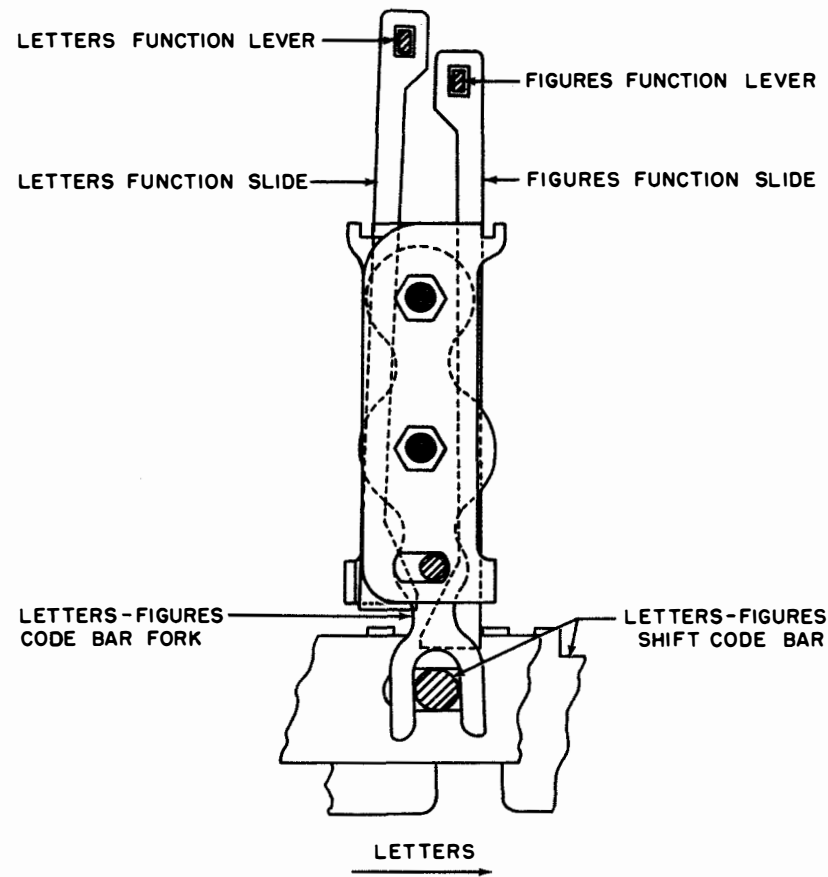

Figure 2-38. Letters - Figures Function Slides, Letters Position

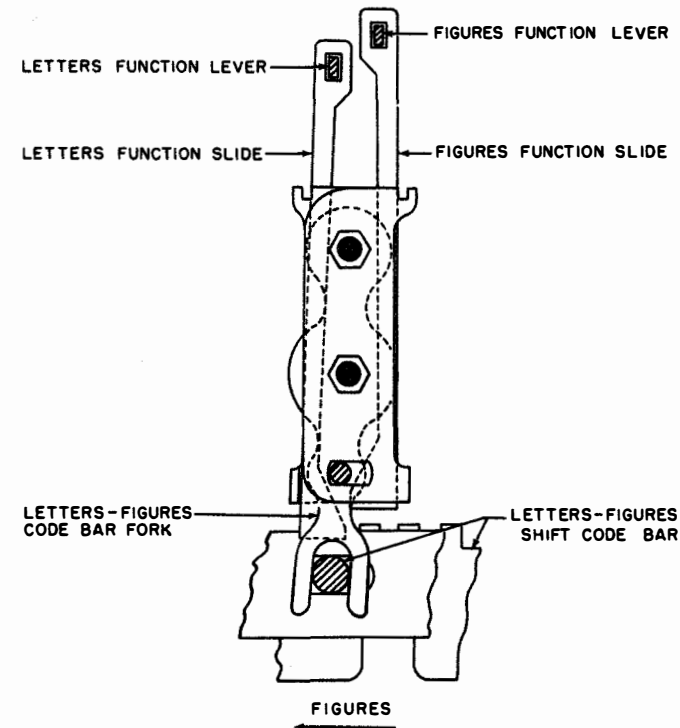

Figure 2-39. Letters - Figures Function Slides, Figures Position

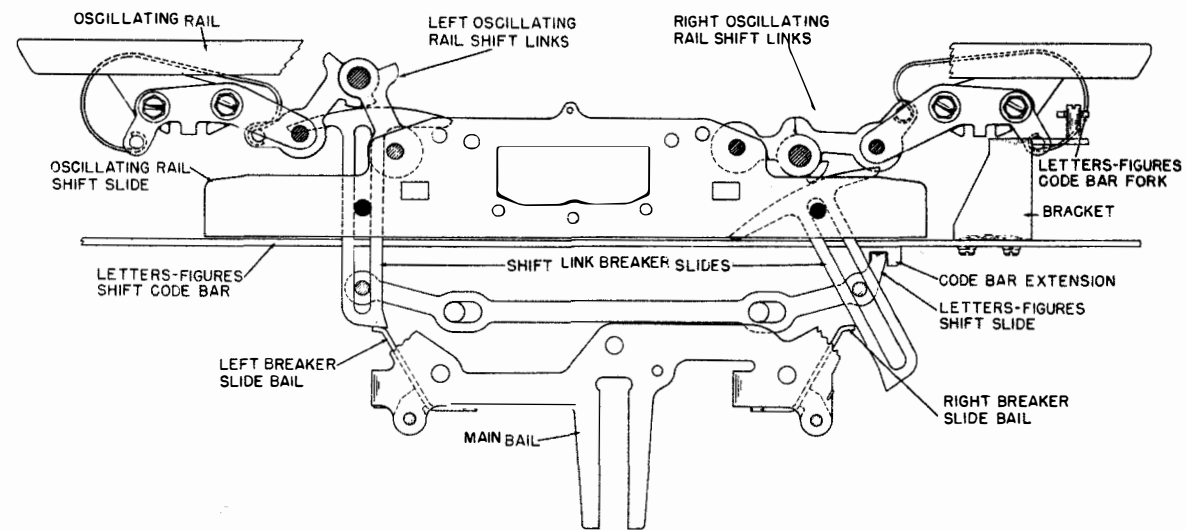

Figure 2-40. Letters - Figures Shift Mechanism, Letters Position

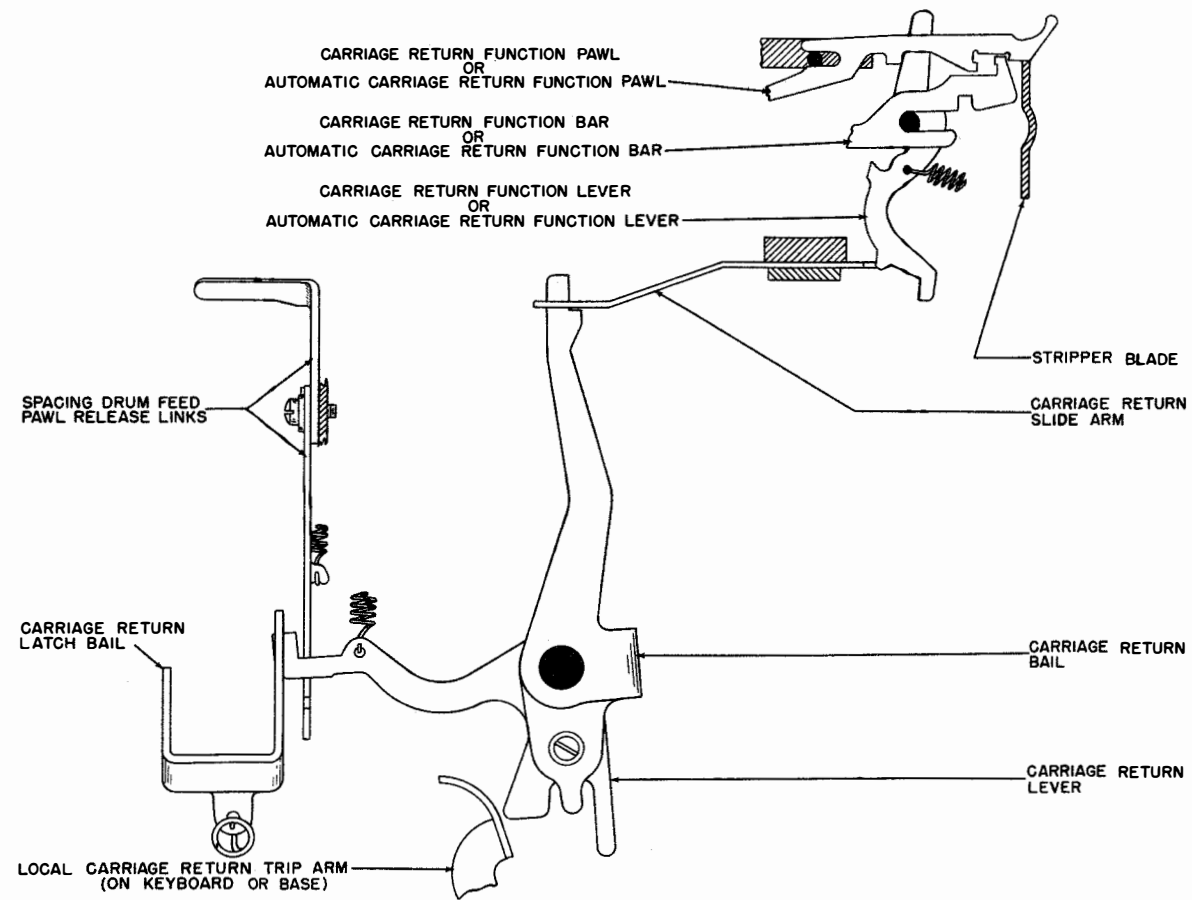

Figure 2-41. Carriage Return Function Mechanism

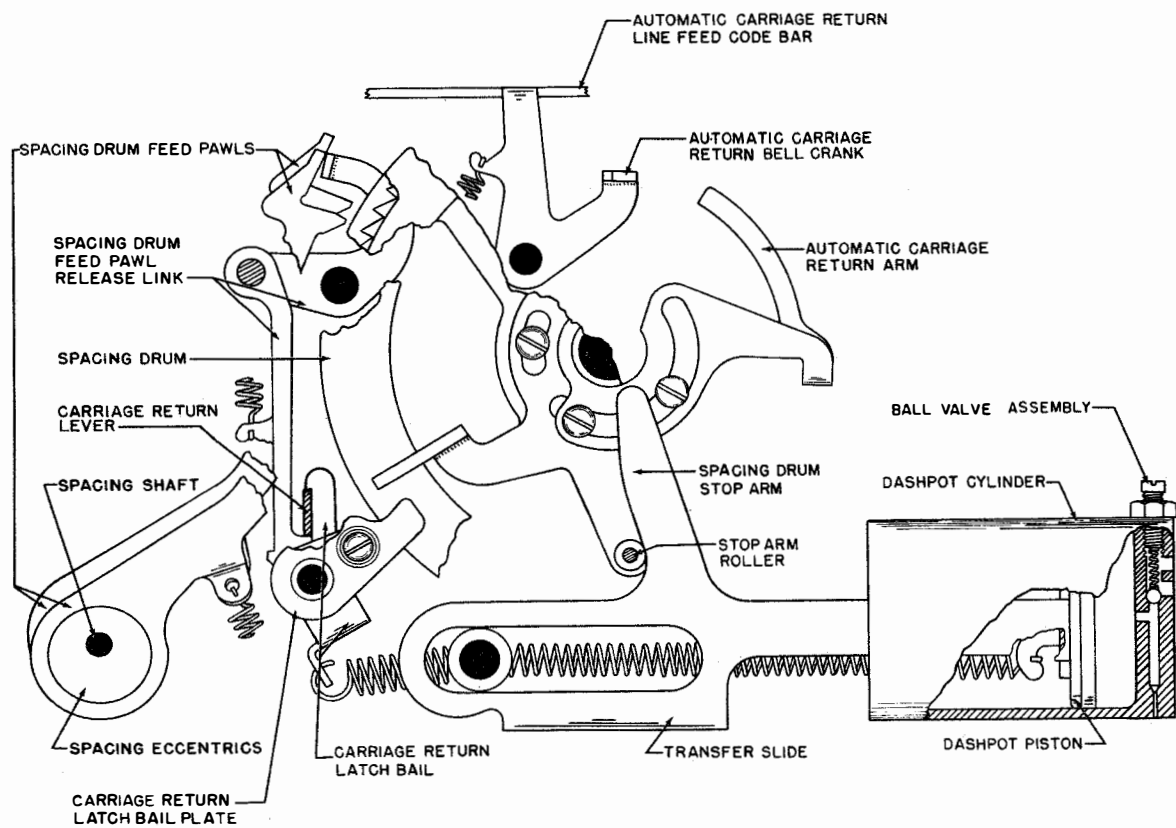

Figure 2-42. Carriage Return Mechanism

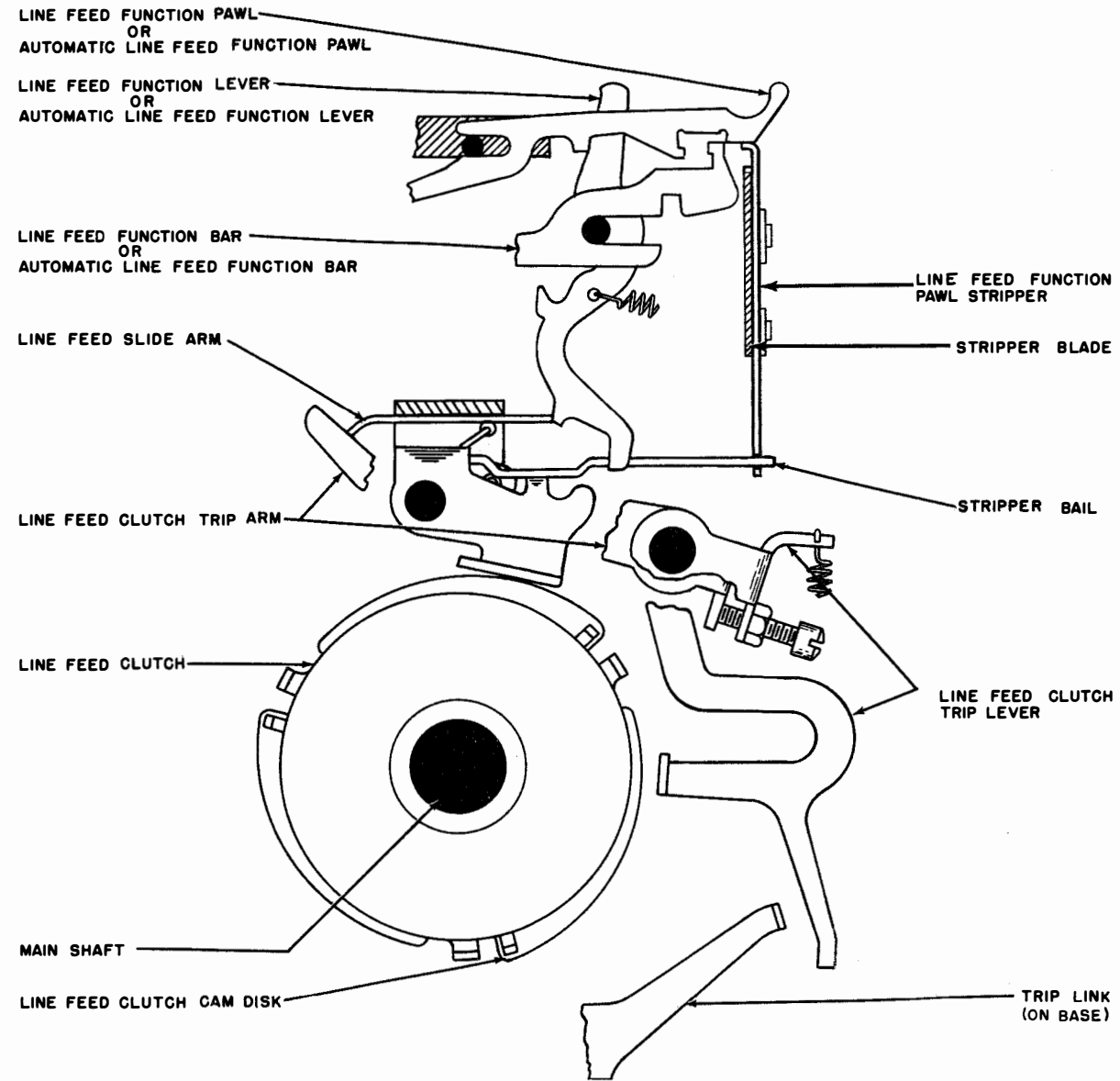

Figure 2-43.

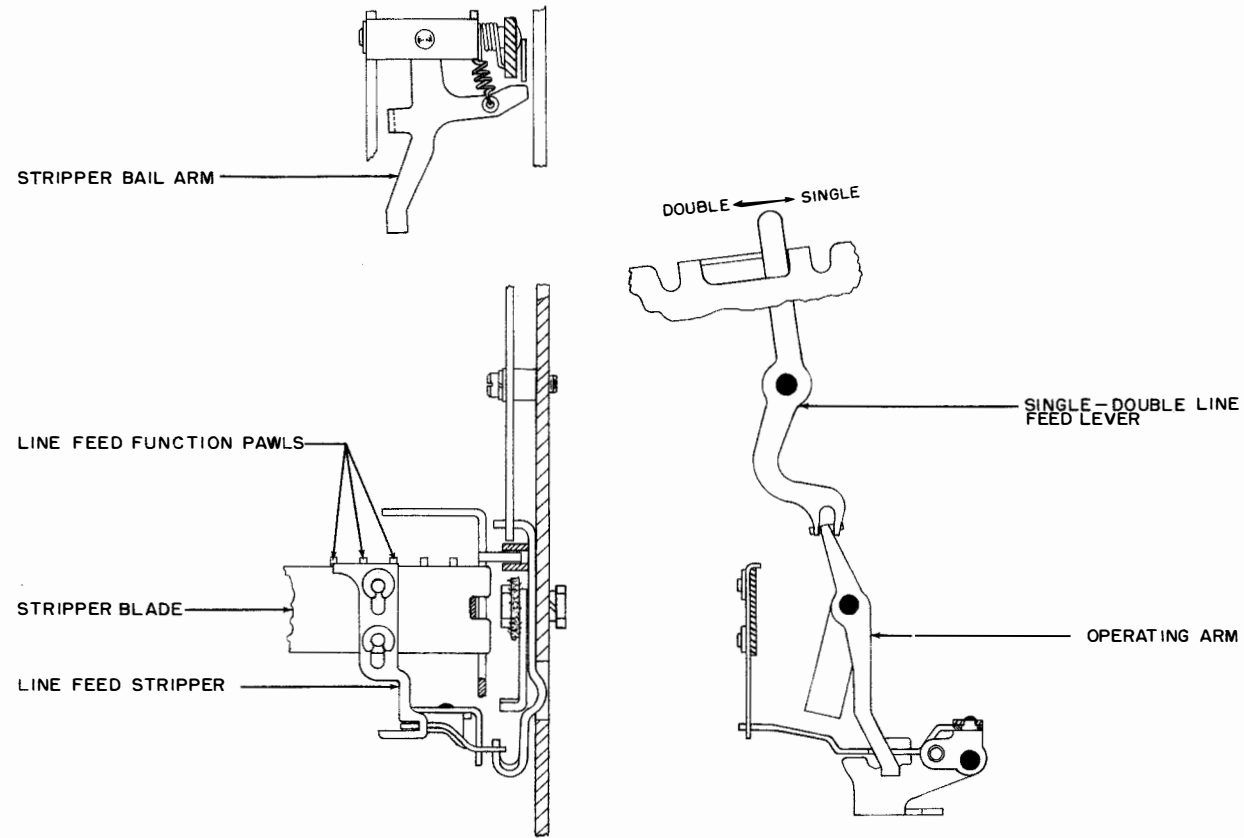

Figure 2-44. Positioning Mechanism for Single or Double Line Feed

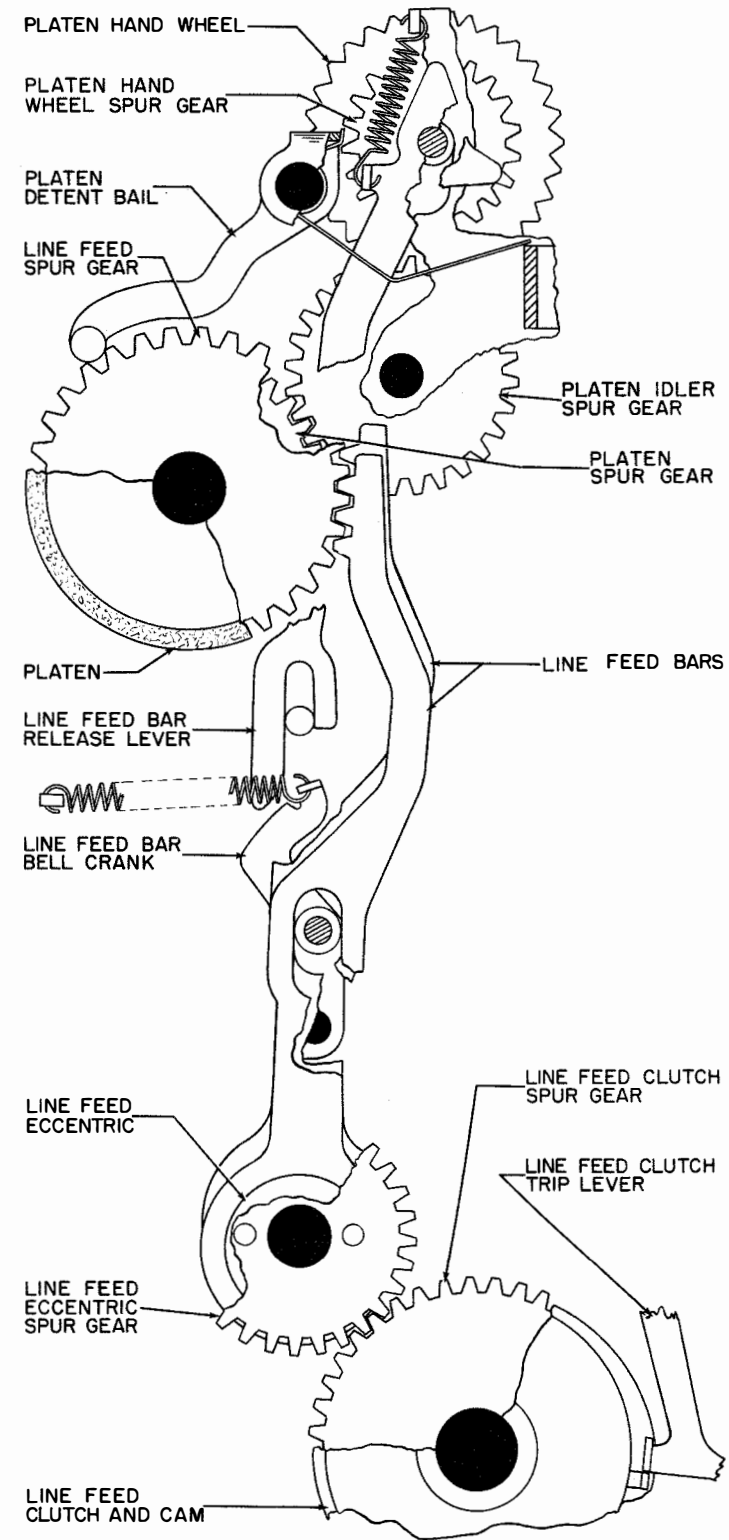

Figure 2-45. Line Feed Mechanism

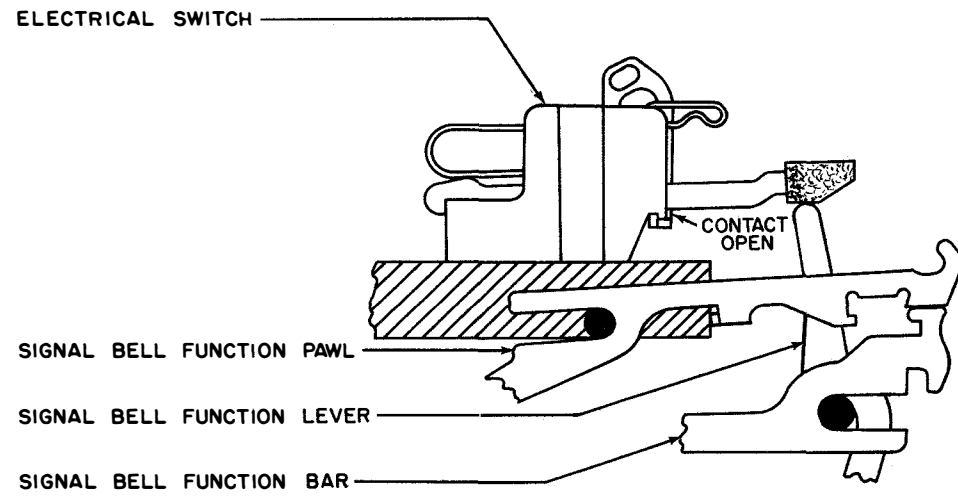

Figure 2-46. Signal Bell Contact Mechanism, Unselected

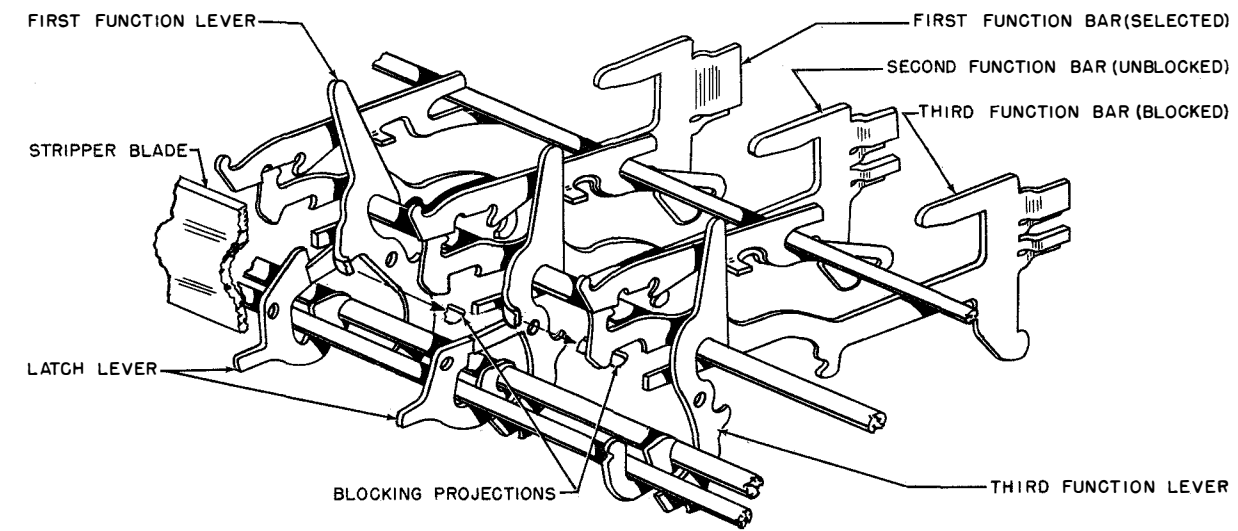

Figure 2-48.

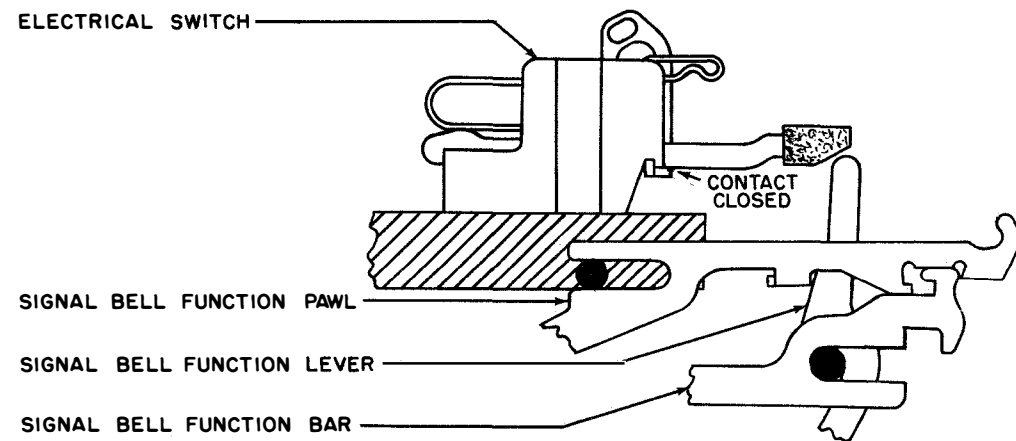

Figure 2-47. Signal Bell Contact Mechanism, Selected

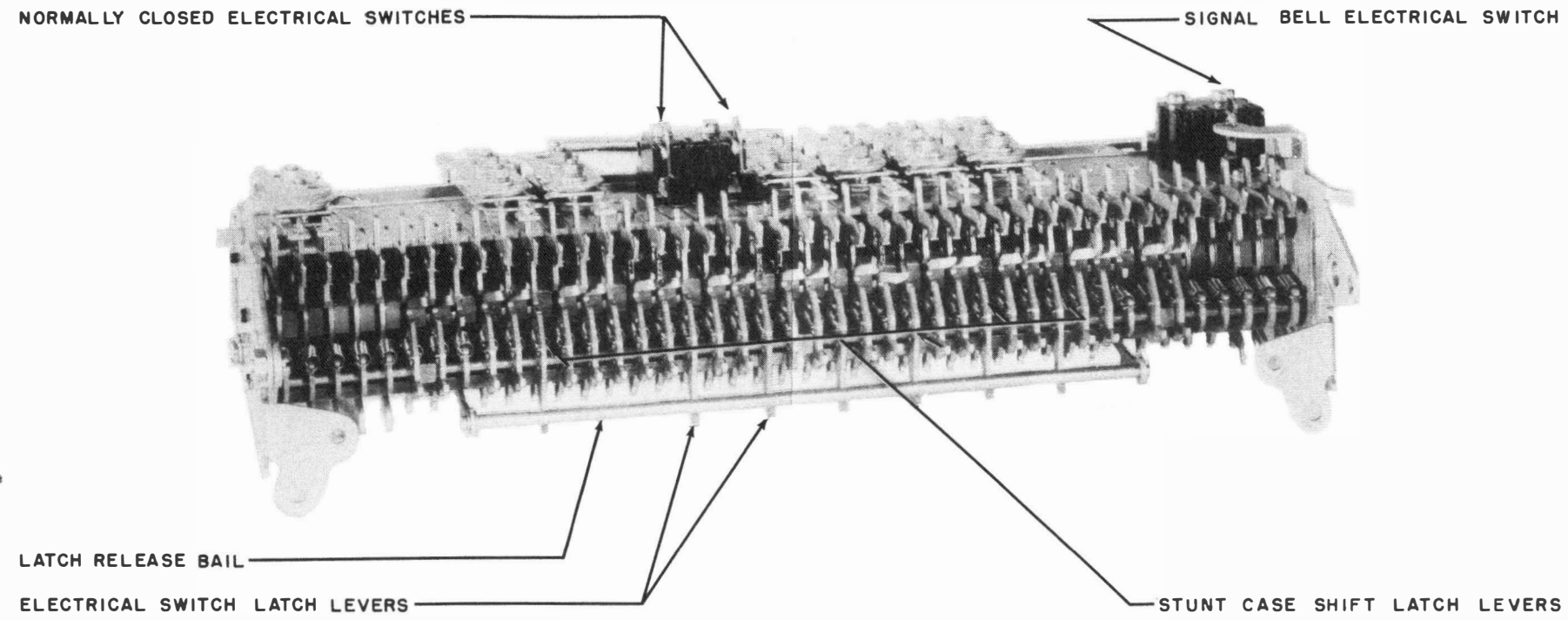

Figure 2-49.

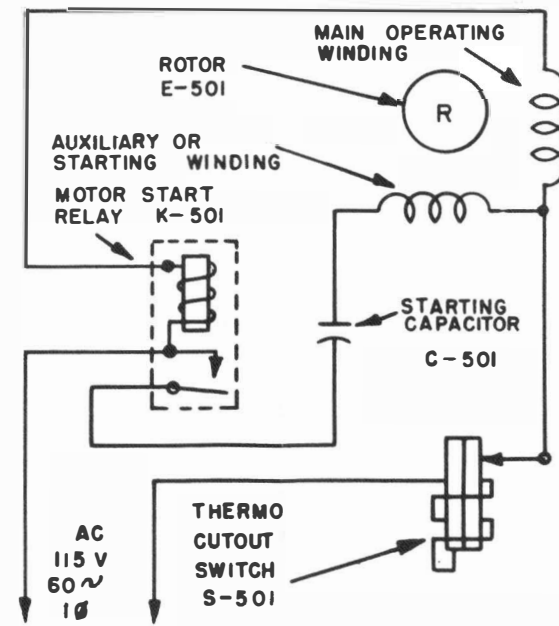

Figure 2-50.