

JUN 10 1963

BULLETIN NO. 219B  
ISSUE 1  
APRIL, 1953

# TELETYPE

## PRINTING TELEGRAPH SYSTEMS

GENERAL DESCRIPTION  
AND  
THEORY OF OPERATION  
MODEL 14 TYPING REPERFORATOR  
(FPR63 AND FPR64)





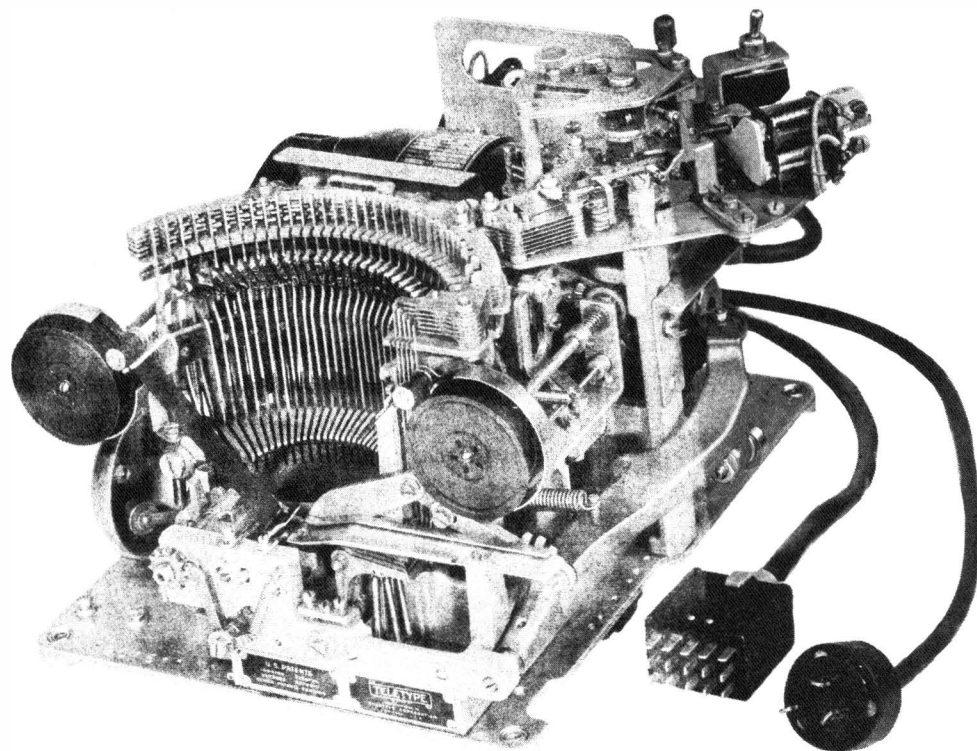

TYPING REPERFORATOR FPR63

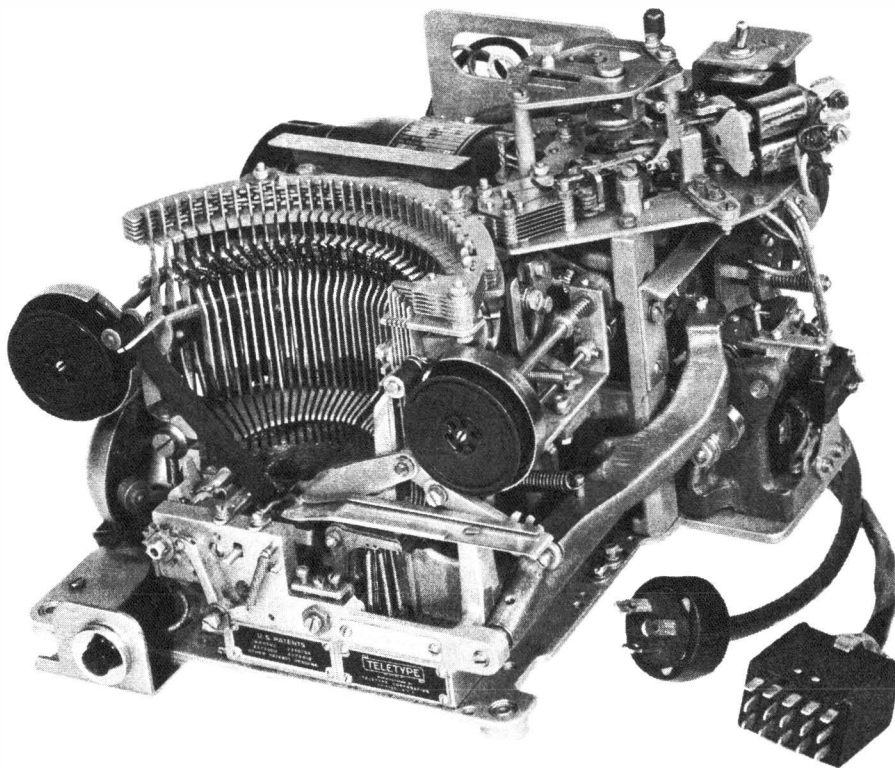

TYPING REPERFORATOR FPR64

## TABLE OF CONTENTS

<u>Paragraph</u>	<u>Page</u>
SECTION 1 - GENERAL DESCRIPTION	
1. General . . . . .	1-1
2. Description . . . . .	1-1
SECTION 2 - THEORY OF OPERATION	
1. General . . . . .	2-1
2. Signaling Code. . . . .	2-1
3. Typing Reperforator . . . . .	2-1
a. General . . . . .	2-1
b. Main Shaft. . . . .	2-1
c. Range Finder Mechanism. . . . .	2-1
d. Selecting Mechanism . . . . .	2-2
e. Printing Mechanism. . . . .	2-3
f. Perforating Mechanism . . . . .	2-4
g. Spacing Mechanism . . . . .	2-4
h. Ribbon Mechanism. . . . .	2-5
(1) Feeding . . . . .	2-5
(2) Reversing . . . . .	2-5
i. Upper and Lower Case Shift Mechanism. . . . .	2-5
j. Signal Bell Mechanism . . . . .	2-6
k. Manual Tape-Feed-Out Lever. . . . .	2-6
m. Automatic Tape-Feed-Out Feature . . . . .	2-6
n. Motor . . . . .	2-7
o. Electrical Connections. . . . .	2-7
p. Orientation . . . . .	2-7



## SECTION 1

## GENERAL DESCRIPTION

## 1. GENERAL

a. The Teletype Model 14 Typing Reperforators provide means for recording telegraph messages on standard width (11/16") perforator tape. Printed characters and corresponding chadless code perforations are automatically recorded in the same operation. These typing reperforators are commonly used for relaying purposes as the recorded message may be automatically retransmitted by a transmitter distributor. The printed characters simplify tape relaying procedures by eliminating the necessity of reading the code perforations.

b. The typing reperforators are equipped to operate at a speed of 60 words per minute but are readily adapted to operate at 75 or 100 words per minute by changing gears and other miscellaneous parts. The units operate from 0.060 ampere signal current and utilize the five-unit start-stop signaling code.

c. The typing reperforators utilize standard perforator tape 11/16" wide. The method of tape perforating known as chadless perforating is employed to permit perforation of the tape in the same space that is occupied by the printed characters. The perforated portions are not completely severed from the tape but remain attached to it at their leading edges so as to form lids over the holes. Therefore, legibility of the printed character is not impaired.

d. Printing and perforating occur simultaneously, but due to the fact that the platen is to the right of the perforator punch block, characters are printed at the right of their

respective perforations. The separation between the printed character and its associated perforation is six character spaces. This separation must be taken into account when tearing message tapes from the unit or when cutting the tape.

## 2. DESCRIPTION -- (See figure 1)

a. The typing reperforators incorporate the necessary electrical and mechanical features for translating the code signals into mechanical action to perforate the tape and print the message in the same operation.

b. Code signals are applied to a two-coil magnet associated with a selecting mechanism which interprets the signals and controls the motions involved in printing a character and perforating the tape. Means are provided for orienting the selector to the received signals. Motion is extended to the various functional mechanisms by the main shaft which is geared to the motor.

c. An automatic tape-feed-out feature, which consists of a tape-feed-out mechanism and a metering mechanism, is the only difference between the two units covered herein. The tape-feed-out mechanism will cause tape to be fed out at the end of every message provided there is a lapse of approximately 500 milliseconds before the start of the next message. The metering mechanism controls the amount of tape that may be fed out at one time. A manual push button is provided to operate the tape-feed-out and metering mechanisms when the automatic feature is not desired.

## SECTION 2

## THEORY OF OPERATION

## 1. GENERAL

This section covers the operating principles and circuit descriptions of the typing reperforator. The unit serves as a receiving-only tape printing and reperforating telegraph set when connected to the terminal facilities of a wire or radio telegraph circuit. It will operate on a signal line current of 0.060 ampere and must receive neutral signals (open and close dc). Synchronous motors require a power supply of 110 volts (plus or minus 10 per cent), 60 cycle, single phase, alternating current. To avoid loss in receiving margin with this type of motor, the frequency regulation must be within plus or minus 0.75 per cent.

## 2. SIGNALING CODE -- (See figure 3)

The signaling code is a five-unit start-stop code of current and no-current intervals. Intervals during which the selector magnet is energized are known as marking impulses and those during which the magnet is not energized are known as spacing intervals. Each group of five selecting intervals is preceded by a start interval (no-current) and is followed by a stop impulse (current) both of which are used to maintain synchronism between the transmitting and receiving apparatus. The code is shown graphically in Figure 3.

## 3. TYPING REPERFORATOR

a. GENERAL - Each typing reperforator consists essentially of a main shaft, a selector mechanism, a tape perforating and feeding mechanism, a printing mechanism, and a ribbon feed and reverse mechanism. Also included are a signal bell and a manual tape-feed-out lever. In addition to the above, one of the two units covered herein includes an automatic tape-feed-out mechanism, a metering mechanism, and a manual tape-feed-out push button. Each unit is equipped with a power cord for connecting the motor to the power supply, and a cable with a plug for connecting the operating circuits to the associated apparatus.

## b. MAIN SHAFT -- (See figure 4)

(1) The main shaft is mounted in a vertical position and is supported by ball type bearings at its upper and lower ends. The shaft is driven by a motor through the medium of a pinion and gear.

(2) Motion for the setting up of selections and for the performance of all functions is derived from cams mounted on the main shaft. A selector cam sleeve is fitted over the upper end of the main shaft and is driven by a

friction clutch formed by two pairs of steel disks separated by felt washers. The clutch derives its driving force from the two outer disks which are keyed to the main shaft. The selector cam sleeve consists of a stop arm, two notched cams (armature and locking), and six cam teeth. The stop arm, in its travel, is intercepted by a stop lever on a range finder assembly located above the main shaft. The armature cam (uppermost) actuates the armature lever. The locking cam (second from the top) actuates the locking lever. The five upper cam teeth actuate five selector levers. The sixth (lower) cam tooth disengages a pivoted clutch-throwout lever from the driven number of a ratchet-tooth clutch. A compression spring causes the clutch members to engage. Rotation of a main bail cam and punch arm cam is controlled by the clutch throwout lever and clutch. A helical gear, located near the lower end of the shaft, is provided for driving the automatic tape-feed-out mechanism shaft. The gear is supplied on all units to facilitate the addition of the tape-feed-out mechanism when desired.

(3) The main shaft rotates continuously while the motor is running. During the time in which a closed line circuit (MARKING) condition exists, the selector magnet coils are energized and hold the armature against the magnet core. In this stop position, the selector cam sleeve is held stationary under control of the stop lever on the range finder mechanism and the ratchet-tooth clutch is held disengaged by the clutch throwout lever. While any code combination is being received, the selector cam sleeve makes one revolution. The main bail cam and punch arm cam, under control of the selector cam sleeve through the medium of the clutch throwout lever, makes one revolution subsequent to each revolution of the selector cam sleeve.

## c. RANGE FINDER MECHANISM -- (See figure 5)

(1) In order to establish operating margins for the typing reperforators, it is necessary that the sampling of the signal by the selecting mechanism occurs at the most favorable portion of the signal intervals. This is referred to as orientation and is accomplished by means of the range finder mechanism.

(2) The range finder includes a latching mechanism that determines the stopping position of the selector cam sleeve. It consists of a mounting plate with a graduated scale, an index arm with a thumb screw, a stop lever, trip latch, bell crank, and trip-latch plunger.

(3) The angular position of the stop lever is controlled by the index arm so as to stop the selector cam sleeve at the required position.



The trip latch, under tension from a compression spring, latches the stop lever which, in turn, blocks the stop arm and consequently holds the selector cam sleeve in the stop position.

(4) Release of the stop lever occurs when the selector magnet is de-energized and the armature lever, under tension of its spring, impresses the trip-off screw against the trip-latch plunger. Movement of the plunger tilts the bell crank and raises the trip-latch clear of the stop lever. Unlatching of the stop lever releases the stop arm and allows the selector cam sleeve to rotate.

d. SELECTING MECHANISM -- (See figure 6)

(1) The selecting mechanism translates the selecting intervals of any code combination into the mechanical motion necessary for positioning the code bars in accordance with the selecting intervals received during the selecting cycle. The selector consists essentially of a two-coil selector magnet, an armature and armature lever, a selector arm, locking lever, and five each of selector levers, swords, and T levers.

(2) The armature and armature lever pivots on the selector magnet bracket. The armature lever extends above the selector arm and, under tension of the armature lever spring, rides the armature cam on the selector cam sleeve. This cam impresses the armature against the magnet core in timed relation to the code intervals of any code combination being received. If the magnet is not energized when the armature is presented to it, the armature is immediately retracted by the armature lever spring. If the magnet is energized, the armature is held by the magnet for the duration of the marking impulse. The armature lever is equipped with two adjustable screws; the trip-off screw on an upper extension and the selector arm operating screw on a lower extension. A selector arm spring forms a yield linkage between the selector arm and the armature lever, and tends to hold the selector arm against the head of the selector arm operating screw.

(3) The selector arm pivots on a bracket located in front of the magnet bracket. The selector arm is positioned so that vertical extensions of the arm present a blocking surface to the arms of the five swords. A locking wedge, with a stud extending downward, is attached to the forward end of the selector arm. A stop detent, into which the stud projects, limits the travel of the selector arm and tends to hold it to either side.

(4) The locking wedge is acted upon by a locking lever (see figure 7), the forward extension of which locks the selector arm to the

right (MARKING) or left (SPACING) as the locking lever drops into each indent of the locking cam on the selector cam sleeve. The locking lever rides its cam under tension from the locking lever spring.

(5) The five selecting levers and the swords, which are coupled to the levers by floating pivots, lie between separator plates. The swords are under slight pressure from the leaf springs of these plates. The selector levers pivot on a common post and, under tension of their springs, impress the tips of the swords against the arms of the T levers. The T levers also lie between the separator plates and pivot on a common post. The five cam teeth on the selector cam sleeve actuate the five selector levers in sequence and cause the swords to be withdrawn from the T levers for repositioning by the selector arm.

(6) Selection of a character is accomplished as follows:

(a) From an idling condition, under which the main shaft rotates with the selector magnet energized and the selector cam sleeve and main bail and punch arm cam held stationary, the selecting cycle is initiated by the reception of the start interval (no current - SPACING). The armature lever spring retracts the armature and armature lever, and with it the selector arm, to the left (SPACING) side. Pressure on the trip-latch plunger by the trip-off screw causes release of the selector cam sleeve by the range finder mechanism.

(b) During rotation of the sleeve, the armature will be impressed against the core of the magnet each time the armature lever rises from an indent in its cam. Assuming that code intervals representing the character Y are being applied to the magnet, the first will be MARKING (current). This impulse will hold the armature attracted to the magnet on the first presentation. The selector arm, co-active with the armature and armature lever, will likewise be in its MARKING position where it will be immediately locked by the locking lever as it drops from the high part of its cam. The No. 1 selector lever, riding to the peak of its cam, will shift the No. 1 sword in the direction of the selector arm. Assuming that the tip of the sword is in the SPACING position (tip toward the right as viewed from the front of the unit), its right arm will be blocked by the selector arm, causing the tip of the sword to shift to the MARKING position (left). As the No. 1 selector lever drops from the peak of its cam, the No. 1 sword will be impressed against the left arm of the No. 1 T lever, causing it to rotate counter-clockwise (as viewed from above) due to tension exerted by the selector lever spring. If the tip of the No. 1 sword is in the MARKING position when responding to the

selector action described in the foregoing, it will not require repositioning and will merely perform a simple motion without contacting the selector arm. The armature will again be impressed against the magnet core in time with the No. 2 code interval, but since this interval is SPACING (no current), the armature and selector arm will immediately be returned to their SPACING positions in time for the selector arm to be locked in that position by the locking lever. The No. 2 sword will move toward the selector arm as its associated selector lever is actuated, and its left arm will be blocked by the selector arm if its tip is in the MARKING position (left). The tip of the sword will be shifted to the SPACING position where it will depart clockwise motion to the No. 2 T lever as the No. 2 selector lever drops off the peak of its cam.

(c) Corresponding actions accompany the reception of the third impulse MARKING, fourth SPACING, and fifth MARKING, for completion of the Y character selection. Subsequently Nos. 3 and 5 T levers will assume positions corresponding to No. 1, while No. 4 will correspond to No. 2. One end of each T lever extends into the notch of the associated code bar. The code bars are positioned horizontally between spacers mounted on two studs on the pull bar guide. The clockwise or counter-clockwise movement of the T levers shifts the code bars to the left (SPACING) or right (MARKING) respectively.

(d) During reception of the fifth code interval, the selector cam sleeve will have rotated sufficiently to cause the sixth cam tooth (lower) to strike the clutch throwout lever and disengage it from the driven member of the clutch. This tripping action initiates the printing and perforating cycle.

(e) Immediately following the fifth code interval, the armature will again be presented to the magnet core where it will be retained by the stop impulse (MARKING). During this interval, no locking action will be applied to the selector arm, since, at that time, the locking lever will be riding the long high part of its cam. During the stop interval, the stop arm of the selector cam sleeve will come to rest against the stop lever on the range finder, thus ending the selecting cycle.

#### e. PRINTING MECHANISM -- (See Figure 8)

(1) The motive force for the performance of printing and other functions (except selecting, perforating, and spacing) is derived from a main bail spring through the medium of a main bail, a main bail plunger, a main bail lever, a main bail bell crank roller, and the main bail cam. In the normal stop position, the main bail bell crank roller is on the high part of its cam. In this position the camming surface of the main bail is in contact with the camming

surfaces on the rear edge of a set of pull bars and holds them forward away from the code bars so that the code bars may be positioned by the selector T levers.

(2) The pull bars are positioned vertically in a type bar segment and the pull bar guide with their upper ends in front of notched code bars. The pull bars are held against the main bail or the code bars by the pull bar springs. The rear edge of each pull bar has a hook-like projection which is engaged by the main bail in its travel. The lower end of each pull bar forms a rack and gear connection with an associated type bar. The type bars pivot on a fulcrum rod at their lower ends so that upper movement of a pull bar by the main bail will cause a downward movement of the type bar toward the platen.

(3) Printing of a selected character is accomplished as follows:

(a) Following the selecting cycle, the lower tooth on the selector cam sleeve strikes the clutch throwout lever and disengages it from the clutch driven member. The main shaft clutch spring causes the clutch members to engage. This allows the main bail cam and punch arm cam to make one revolution. When the main bail cam rotates, the main bail bell crank roller rides down on the low part of the cam and, through the main bail bell crank, the main bail lever and the main bail plunger, allows the main bail spring to pull the main bail upward. As the main bail moves upward, its camming surface moves out of contact with the pull bars and allows the pull bar springs to move the pull bars toward the code bars. The unselected pull bars are blocked by the code bars, but the selected pull bar moves into the path set up by the alignment of notches in the code bars. The hook-like projection on the rear edge of the selected pull bar is engaged by the main bail thereby raising the pull bar. As the pull bar is moved upward, the associated type bar pivots at its lower end while its upper end, which contains the type pallet, moves downward toward the platen. As the pull bar nears the top of its travel, the sloping surface above the rear hook-like projection strikes a stripper plate mounted on the under side of the pull bar guide. This causes the pull bar to be disengaged from the main bail shortly before the type bar reaches the platen. Momentum carries the type bar the remaining distance to the platen.

(b) During the early part of the upward stroke of the main bail, a locking lever, (see figure 9) located in the extreme right-hand slot of the pull bar guide and under tension of the locking lever spring, is brought into engagement with "V" shaped notches in the code bars. This locks the code bars in position after each selection and holds them in

that position until the locking lever is cammed out of engagement with the notches by the main bail as the main bail nears the end of its downward stroke. When the code bars are not engaged by the locking lever, they are free to be positioned by the selector T levers.

f. PERFORATING MECHANISM -- (See figure 10)

(1) The locking lever and the code bars control the movement of five notched code bar bell cranks. The code bar bell cranks lie between separator plates and pivot on a vertical stud. The forward ends of the code bar bell cranks make contact with vertical links which pivot on a horizontal stud near their upper ends. The lower ends of the vertical links connect with the upper ends of intermediate bell cranks whose notched forward ends in turn connect with the upper right ends of five punch bell cranks. The lower left ends of the punch bell cranks extend into notches in the punch selector fingers. The motive force for positioning the train of linkage from the code bar bell cranks to the punch selector fingers is derived from the punch bell crank springs.

(2) If a code bar has been positioned to the right (MARKING), the motion of the associated code bar bell crank will be blocked by the right end of the code bar as the locking lever moves toward the code bars, and the punch selector finger will remain in an engaging position under the punch as shown in Figure 10. If a code bar has been positioned to the left (SPACING), the code bar bell crank will be free to follow the locking lever, and the train of linkage between the code bar bell crank and the punch bell crank will be turned in a clockwise direction, thus moving the punch selector finger to the left so its recess will be under the punch.

(3) A punch arm roller rides the punch arm cam and is mounted in the fork of a punch arm casting which extends along the right side of the unit and pivots on pilot screws at each end. An adjustable punch bail link connects the punch arm casting to the upper extension of a punch bail, the lower section of which extends beneath and forms a guide for the punch selector fingers. Through this punch arm casting and punch bail link, motion from the punch arm cam is transferred to the punch bail which pivots on two pilot screws in the perforating assembly casting.

(4) A code punch block is mounted to the perforating assembly casting directly over the left ends of the punch selector fingers. The punch block includes five code punches and a feed hole punch, a spring tensioned retractor plate for removing the punches from the tape, and six strippers for driving the perforated tape lids from the upper die plate. An upstop

screw in the punch bail limits overtravel of the punches to prevent mutilation of the tape.

(5) Code perforation is accomplished as follows:

(a) Following a selecting cycle, the punch arm cam is allowed to rotate (see paragraph 3.e.(3) (a) of this section). As the punch arm cam starts to rotate, the roller on the punch arm casting rides onto the high part of the cam and transfers motion, through the punch bail link, to the punch bail. The punch bail raises the punch selector fingers during each revolution of the punch arm cam. Punch selector fingers that remain in the right (punching) position under their respective code punches will drive the code punches upward and perforate the tape. A projection on the punch bail engages the feed hole punch and drives it upward to perforate a feed hole during every operation of the punch bail.

(b) As the punch arm casting roller rides the low part of the punch arm cam, the punch bail and punch selector fingers are lowered from the punches. This allows the punch retractor, under tension of its two springs, to remove the punches from the tape, and the strippers, under tension of their springs, to drive the perforated tape lids from the upper guide plate. This action occurs just before a tape feed pawl, attached to an extension of the punch bail, rotates a feed roll ratchet one notch. As the punch arm cam completes its revolution, the clutch throwout lever rides the high part of the cam on the clutch driven member and disengages the clutch members.

(6) In summarizing the selecting, printing, and perforating operations described in the foregoing, it should be noted that the selecting cycle is immediately followed by the operating cycle. Near the end of the selecting cycle, the lower tooth on the selector cam sleeve trips the clutch throwout lever, allowing the main bail cam and punch arm cam to make one revolution. Thus it may be seen that the printing of a character or the operation of a function requires time equivalent to both a selecting and operating cycle. However, the positioning of the selector swords for the selection of the next character may be made at the same time that the locking lever locks the code bars in place for the performance of the previous operation. Overlapping action is thereby effected.

g. SPACING MECHANISM -- (See figures 10 and 11)

(1) The spacing mechanism consists of a feed roll with feed pins and teeth, a feed pawl, a tape tension lever, a star wheel, and a detent lever with roller.

(2) Tape is spaced by the rotation of a feed roll which has pins on its periphery that engage feed perforations in the tape. The tape is fed over the feed roll and under the tape tension lever which is spring tensioned against the feed roll to hold the tape in engagement with the feed pins. As the punch bail moves upward to perforate the tape, the feed pawl, held against the feed roll under tension of its spring, also moves upward and engages a higher tooth on the feed roll. As the punch bail nears the end of its downward stroke and the punches are removed from the tape, the feed pawl, following the punch bail, rotates the feed roll one notch. Simultaneously with this action, the detent lever roller rides over a tooth on the star wheel to insure even spacing of the feed hole perforations.

(3) When installing a new roll of tape, it is necessary to assist the mechanism manually until properly spaced feed holes reach the feed roll. This may be done by applying a slight pressure to the tape tension lever so that the pins on the feed roll grip the tape.

#### h. RIBBON MECHANISM

(1) FEEDING -- (See figure 12). Each of the ribbon spool assemblies has a bevel gear attached to the rear end of a ribbon spool shaft on which a ribbon spool is mounted. A ribbon feed shaft, equipped with a bevel gear at each end and a ratchet wheel in the center, is mounted horizontally across the rear of the unit. The shaft may be shifted laterally so that the left or right bevel gear will mesh with the left or right ribbon spool shaft bevel gear respectively. A ribbon feed lever and roller, located behind the tape feed shaft, is held against the main bail plunger under tension of the ribbon feed lever spring. Attached to the upper end of the ribbon feed lever is a ribbon feed pawl which engages the teeth on the ribbon feed ratchet wheel. As the main bail moves upward, the ribbon feed lever roller rides into an indent on the main bail plunger causing the ribbon feed pawl to move toward the rear and engage a tooth on the ribbon feed ratchet wheel. As the main bail moves downward, the ribbon feed lever roller rides out of the indent in the main bail plunger causing the ribbon feed pawl to move forward and rotate the ribbon feed ratchet wheel. This motion is transferred through the bevel gear arrangement to a ribbon spool shaft, causing one of the ribbon spools to revolve.

(2) REVERSING -- (See figure 13). When the ribbon has become completely unwound from one spool, it is necessary to reverse its direction so it can rewind. This is accomplished automatically by disengaging one set of bevel gears and engaging the other set. Assuming that the ribbon is being wound on the left ribbon spool and is almost unwound from the

right ribbon spool, an eyelet which is fastened to the ribbon will catch in the slot of the right ribbon reverse arm and move it downward. Motion is thereby transferred, through the ribbon reverse shaft, the reverse shaft arm, and the reverse pawl link, to the right ribbon reverse pawl causing it to move into the path of the ribbon reverse bail which is mounted on a rear extension of the main bail. As the bail moves downward it engages the ribbon reverse pawl causing the ribbon reverse lever, which is attached to the pawl, to engage a shoulder on the ribbon feed shaft and move it to the right. This will disengage the left set of bevel gears and engage the right set of bevel gears. The ribbon will then be wound on the right ribbon spool. The reversing operation takes place in a similar manner on the left ribbon spool assembly when the eyelet near the left end of the ribbon engages the slot in the left ribbon reverse arm.

#### i. UPPER AND LOWER CASE SHIFT MECHANISM -- (See figure 14)

(1) The platen is a plastic disk about 1/4" in diameter that sets in a platen block mounted on a platen shaft that may be shifted back and forth beneath the tape. A platen guide shaft, attached to the front of the platen block, and the platen shaft extend through guide holes provided in the perforating assembly casting.

(2) To print figures when the platen is in the LETTERS position (to the rear), the figures pull bar (extreme right next to the locking lever) must be selected. As the main bail moves upward, it raises the figures pull bar. A horizontal projection on the lower end of the pull bar engages the right arm of the shift lever and unlatches its notched left arm from the shift bell crank on the platen shaft allowing the platen shift spring to move the platen block to the FIGURES position (forward). The platen will then be in position to receive the figures (upper case) characters of the type pallets.

(3) When the letters pull bar (second from the left) is selected and raised by the main bail, a horizontal projection on its lower end engages the left arm of the shift rocker lever and rotates it about its pivot. The right arm of the rocker lever moves the rear arm of the shift rocker arm downward causing the shift rocker, attached to the shift rocker arm, to rotate about its pivot. As it rotates, its upper notched arm, into which the left arm of the shift bell crank fits, moves toward the rear. Motion is thereby transferred, through the platen shaft, to the platen block, moving it toward the rear. When the platen reaches the LETTERS position, the shift bell crank is latched by the left arm of the shift lever and held in that position.

(4) If the platen is in the FIGURES position and the space combination is received, an unshift-on-space pull bar (extreme left) is selected. As it is raised by the main bail, a horizontal projection on its lower end will engage the left arm of the shift rocker lever and, as described in the foregoing, move the platen to the LETTERS position.

**j. SIGNAL BELL MECHANISM -- (See figure 15)**

(1) The unit is provided with a signal bell that will sound when the S combination is received while the platen is in the FIGURES position. A gong and bell hammer are mounted at the left front corner of the unit. The bell hammer is operated by the bell pull bar (third from left) when it is selected in place of the S pull bar (fourth from left).

(2) When the platen is in the FIGURES position, a lower extension of the shift rocker holds the pull bar lockout lever in such a position as to allow the selection of the bell pull bar but to prevent the selection of the S pull bar (see figure 15A). As the selected bell pull bar is raised by the main bail, a horizontal projection at its lower end engages the eccentric screw on the bell hammer causing the hammer to rotate about its pivot and strike the gong (see figure 15B). With the platen in the LETTERS position, the pull bar lockout lever is positioned so that the S pull bar may be selected and the bell pull bar is blocked (see figure 15C).

**k. MANUAL TAPE-FEED-OUT LEVER -- (See figure 5)** A manual tape-feed-out lever is mounted on the rear range finder mounting post just beneath the range finder. Its rearward extension is equipped with a bakelite handle. The forward extension extends alongside the bell crank on the range finder assembly. Operation of the lever tilts the bell crank and raises the trip-latch clear of the stop lever and allows the selector cam sleeve to rotate. Following the tripping off of the clutch throwout lever by the sixth cam tooth, a perforating cycle will be completed. Since the armature remains in the MARKING position due to the steady line current, the LETTERS combination will be perforated in the tape while it is being fed through the punch block. This sequence of operation will continue until the manual tape-feed-out lever is released.

**m. AUTOMATIC TAPE-FEED-OUT FEATURE**

(1) A mechanism for feeding out a predetermined amount of tape automatically, provided the signal line becomes idle for a period of approximately 500 milliseconds, is provided on one of the two units covered herein. The other typing reperforator is equipped with the necessary parts that facilitate the addition of the tape-feed-out feature.

(2) The tape-feed-out mechanism (see figures 16 & 17) of the automatic tape-feed-out feature is mounted at the right rear corner of the unit. A clutch solenoid (with armature) is mounted directly beneath a clutch trip lever. One end of a bell crank is connected to the solenoid armature and the other end extends upward over the solenoid and directly beneath the operating screw in the trip lever. The bell crank disengages a stud on the pivoted clutch trip lever from the driven member of a ratchet tooth clutch. A compression spring causes the clutch members to engage. The driving member is meshed with a gear on the lower portion of the main shaft. Rotation of the clutch shaft is thereby controlled by the trip lever and clutch. A feed cam on the front end of the clutch shaft makes contact with a roller mounted on a lower extension of the punch arm casting. A worm at the rear end of the clutch shaft meshes with a gear on the metering mechanism. A detent lever rides a detent cam mounted on the clutch shaft just behind the driven clutch member.

(3) The metering mechanism (see figure 18) is mounted behind the tape-feed-out mechanism. A worm follower, which pivots on the armature of the control magnet, has a stud at its lower end that rides a worm. This worm receives its motion from the worm on the tape-feed-out mechanism through the medium of a gear. Attached to the upper end of the worm follower is a contact lever that engages the lower end of a contact arm in its travel. Operation of the contact arm breaks the metering contact and opens the circuit through the clutch solenoid.

(4) Automatic tape-feed-out is accomplished as follows:

(a) When the signal line becomes idle for a period of approximately 500 milliseconds, the clutch solenoid and the control magnet are energized by an external source. As the armature is attracted to the solenoid, the bell crank raises the trip lever and stud clear of the clutch driven member. When the clutch members engage the clutch shaft starts to rotate. As the shaft rotates, the feed cam on the front end of the shaft transfers motion to the punch arm casting in a manner similar to the action of the punch arm cam on the main shaft. With each operation of the punch arm casting the tape will be perforated and fed through the punch block as described in paragraphs 3.f.(5) and 3.g.(2) of this section respectively. Since the selector armature remains in the MARKING position due to the steady line current, a series of LETTERS combinations will be perforated in the tape. The feed cam will continue to rotate and operate the punch arm casting as long as the clutch solenoid is energized.

(b) When the clutch shaft starts to rotate as described above, the worm on the rear end of the shaft transfers motion to the worm on the metering mechanism through the medium of a worm gear. When the control magnet was energized as stated above, the worm follower on the armature of the control magnet moved forward and allowed the worm follower stud to engage the worm. As the worm follower moves toward the right with the rotation of the worm, the contact lever moves toward the contact arm of the metering contact. When the contact lever engages the contact arm and breaks the contact, it opens the circuit through the clutch solenoid and thereby releases the solenoid armature. The trip lever spring thereupon pulls the trip lever downward so that the trip lever stud rides upon the high part of the cam on the driven clutch member and disengages the clutch. When the clutch is completely disengaged, the detent lever falls off the high part of the detent cam on the clutch shaft and prevents any reverse rotation of the shaft.

(c) A manual push button, mounted at the left front corner on the reperforator base plate, is provided for operation of the tape-feed-out mechanism when the automatic feature is not desired. The circuit through the clutch solenoid and control magnet is completed by manual operation of the push button. To prevent de-energization of the clutch solenoid upon release of the push button, a switch, wired in parallel with the push button and operated by an extension of the clutch trip lever, is provided. The switch will remain operated until the circuit through the solenoid is opened by the metering contact. The method of feeding out tape and the amount of tape to be fed out are the same as described previously.

(5) The mechanism is non-interfering in its operation which means that it will not interfere with the recording of a message that might begin while tape is being fed out. If reception of code impulses should start while the tape-feed-out mechanism is operating, the start impulse will cause the clutch solenoid to release with the effect that the tape-feed-out clutch will become disengaged and the tape-feed-out mechanism will come to rest before the perforating cycle of the first character of the message begins.

n. MOTOR -- The unit is equipped with a synchronous motor for use with 110 volt, single phase, alternating current at a frequency of 60

cycles per second. It is a 1/40 horsepower, 1800 rpm, ball bearing motor with a starting winding and a running winding. A centrifugally operated switch is in series with the starting winding. The switch is closed when the motor is stopped and remains closed from the time the motor is started until it reaches a speed of approximately 1400 rpm. At that speed the centrifugal force opens the spring tensioned switch and disconnects the starting winding. The motor will continue to accelerate until it reaches synchronous speed (1800 rpm). A fan at the left end of the motor shaft draws air through the end bells as an aid in controlling temperature rise. Rotation of the motor shaft is counter-clockwise as viewed from the fan end.

o. ELECTRICAL CONNECTIONS -- The operating and power circuits are brought out and connected to the upper half of a terminal board located at the rear of the unit. The connections on the lower half of the terminal board terminate in a 15 prong plug and a 3 prong plug which connect to receptacles in the associated apparatus.

p. ORIENTATION

(1) In order to synchronize the action of the selector mechanism with that of the transmitting mechanism at the transmitting station and to utilize the receiving margin of the selector to the best advantage, it is necessary to locate the starting point of the selector cam sleeve at the most favorable position. This is accomplished by positioning the index arm of the range finder.

(2) When available, a signal-distortion test set should be used for orienting the range finder. The index arm, in its final setting, should be at the optimum position for bias in accordance with procedures outlined in the Teletype distortion distributor bulletin applying to the test set.

(3) When a signal-distortion test set is not available, the orientation range may be determined while receiving the characters "RY". The index arm should be moved in one direction until errors appear in the perforated tape and then retracted slowly until the errors disappear. After noting this position, the index arm should be moved toward the opposite end of the scale and the other limit determined in a similar manner. The final setting should be midway between the determined limits.

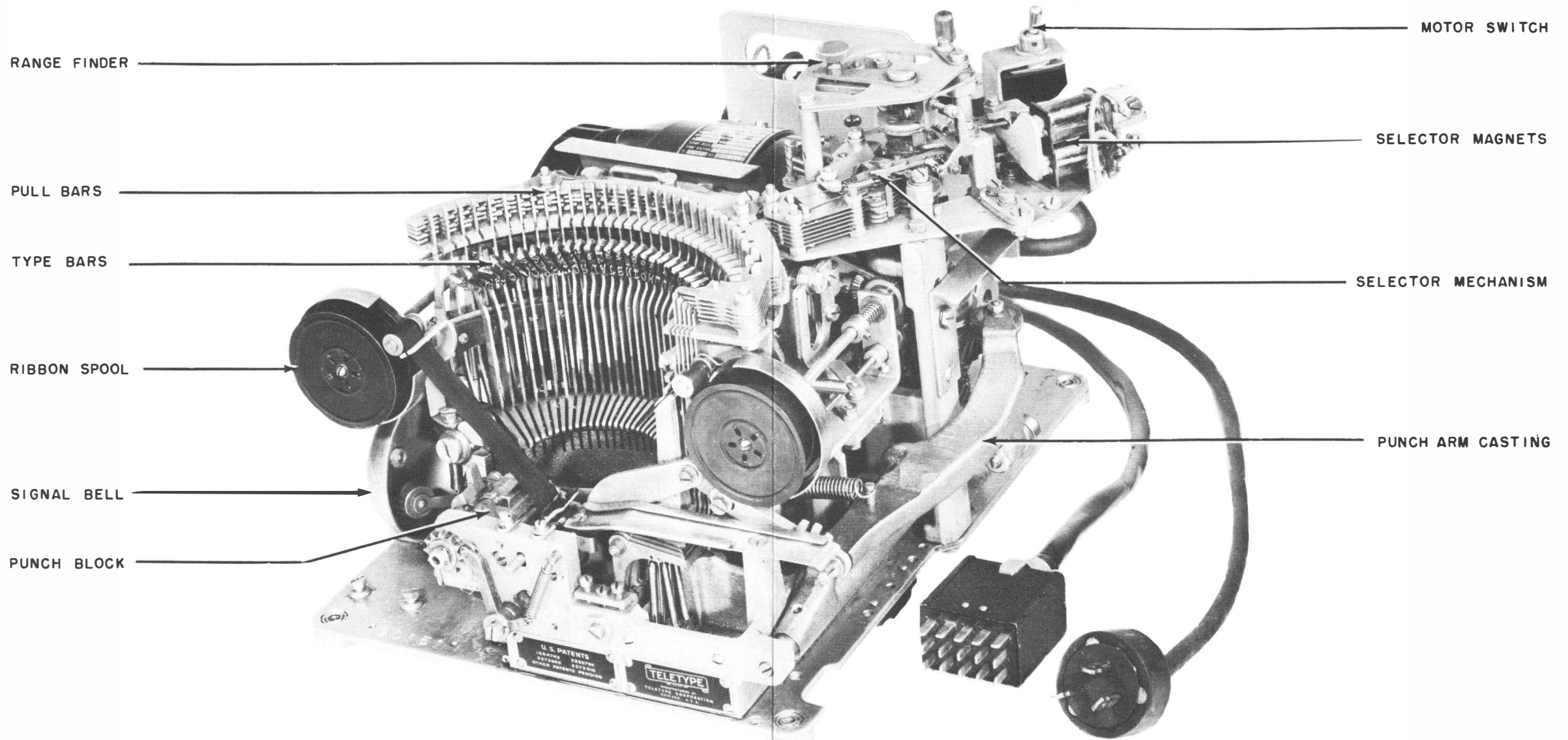

FIGURE 1



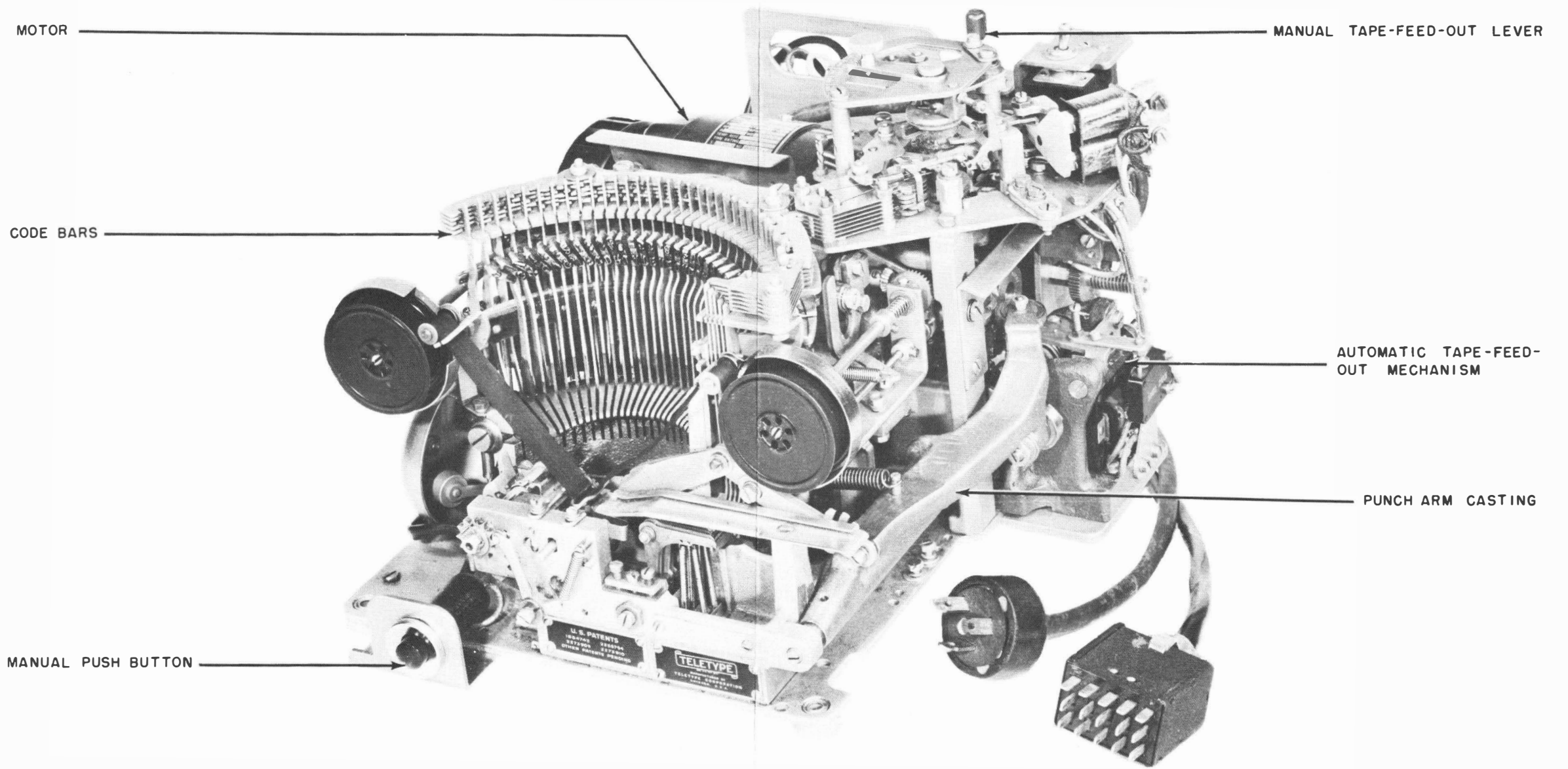

FIGURE 2



UPPER CASE	-	?	:	\$	3	!	B	E	B	'	(	)	.	,	9	ø	1	4	Δ	5	7	;	2	/	6	"	∞	<		SPACE	LTR. SHIFT	FIG. SHIFT
LOWER CASE	A	B	C	D	E	F	G	H	I	J	K	L	M	N	O	P	Q	R	S	T	U	V	W	X	Y	Z	BLANK	C.R.	L.F.	SPACE	LTR. SHIFT	FIG. SHIFT
1	●	●	●	●	●	●	●	●	●	●	●	●	●	●	●	●	●	●	●	●	●	●	●	●	●	●	●	●	●	●	●	●
2	●	●	●	●	●	●	●	●	●	●	●	●	●	●	●	●	●	●	●	●	●	●	●	●	●	●	●	●	●	●	●	●
FEED HOLES	○	○	○	○	○	○	○	○	○	○	○	○	○	○	○	○	○	○	○	○	○	○	○	○	○	○	○	○	○	○	○	○
3	●	●	●	●	●	●	●	●	●	●	●	●	●	●	●	●	●	●	●	●	●	●	●	●	●	●	●	●	●	●	●	●
4	●	●	●	●	●	●	●	●	●	●	●	●	●	●	●	●	●	●	●	●	●	●	●	●	●	●	●	●	●	●	●	●
5	●	●	●	●	●	●	●	●	●	●	●	●	●	●	●	●	●	●	●	●	●	●	●	●	●	●	●	●	●	●	●	●

FIGURE 3

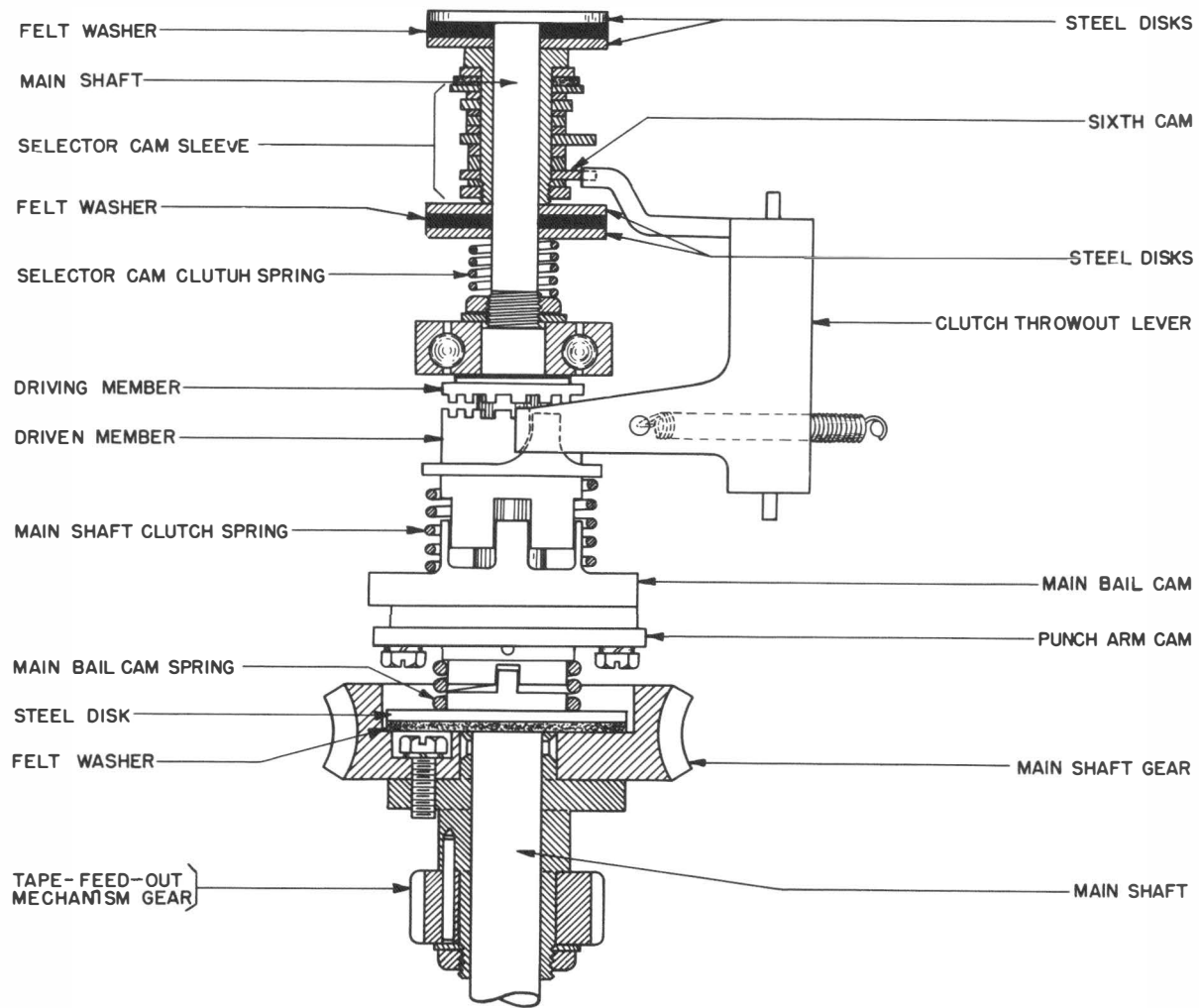

FIGURE 4

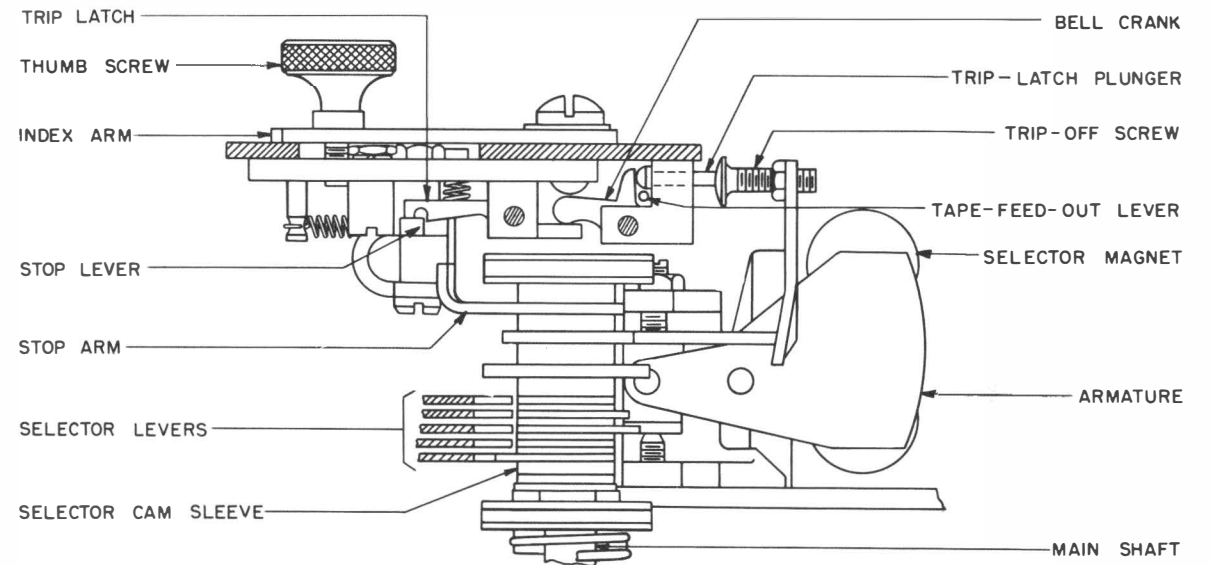

FIGURE 5

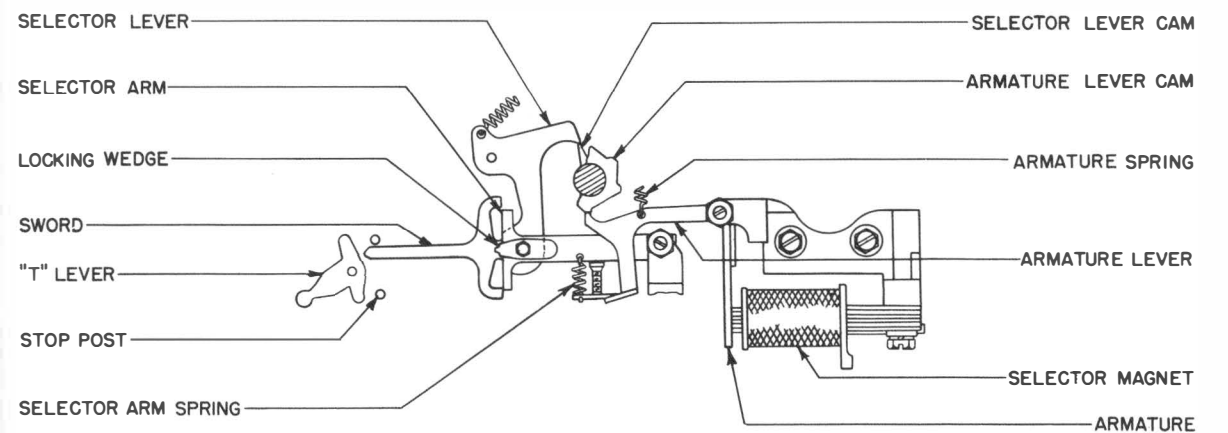

FIGURE 6

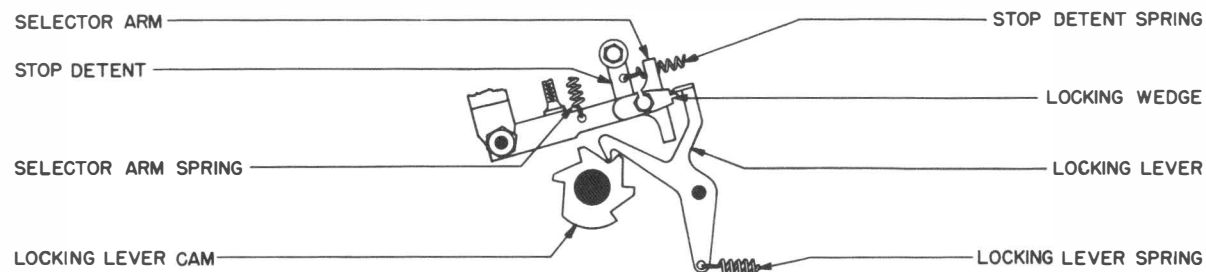

FIGURE 7

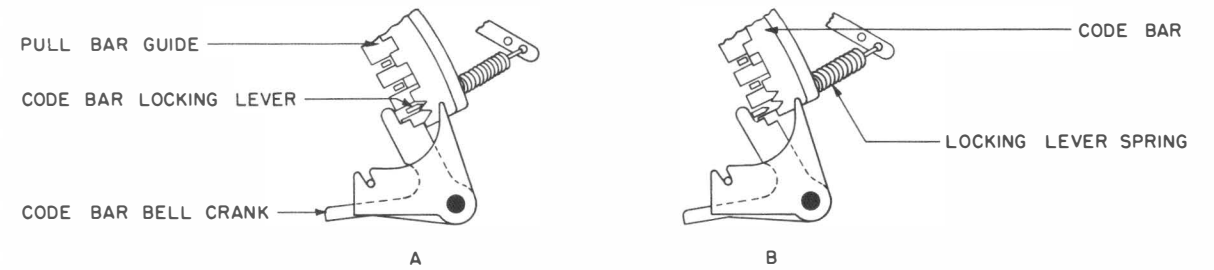

FIGURE 9

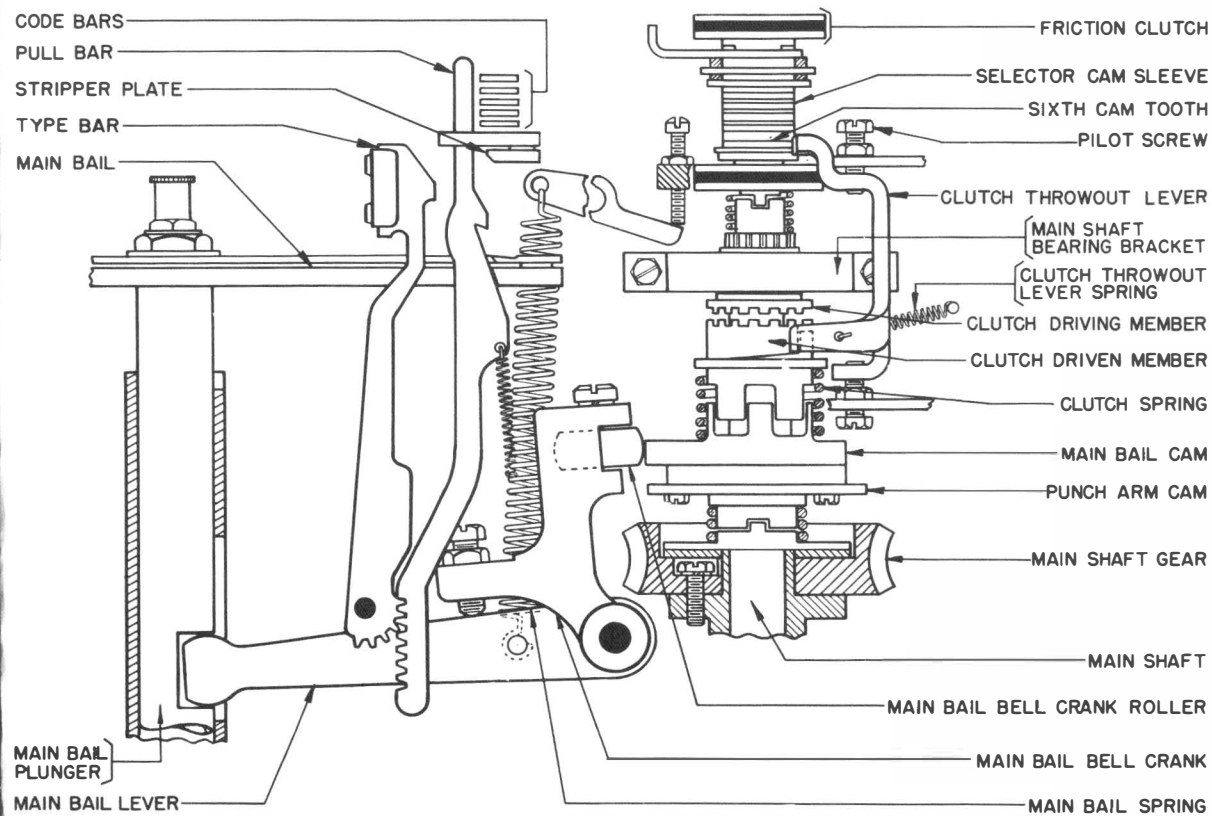

FIGURE 8

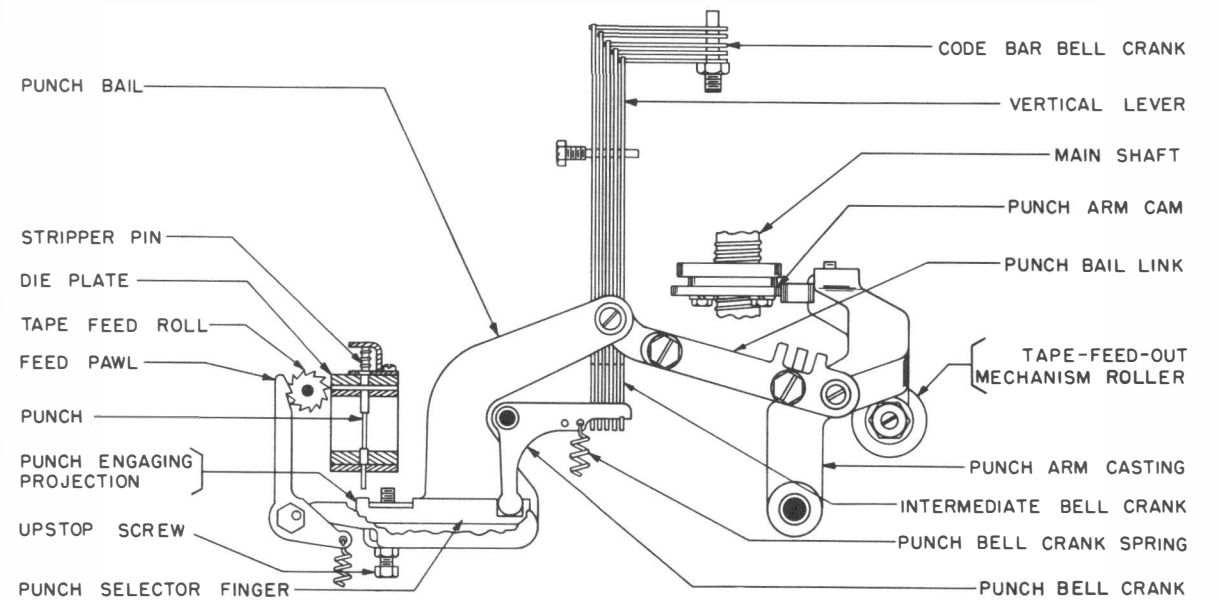

FIGURE 10

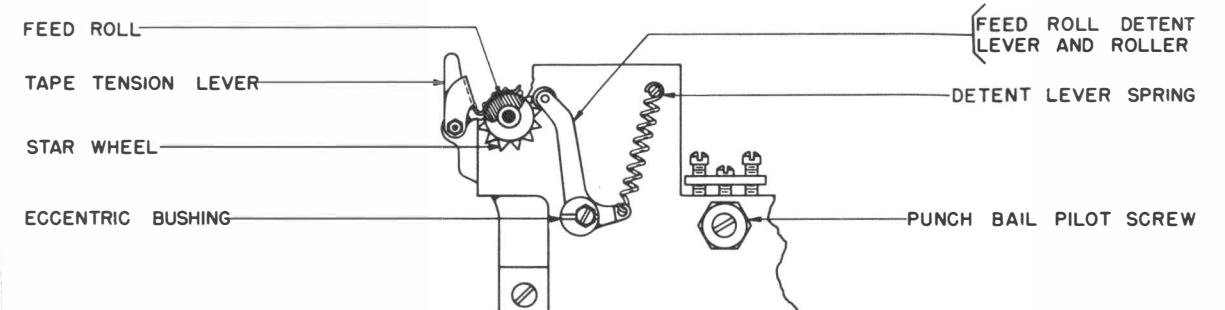

FIGURE 11

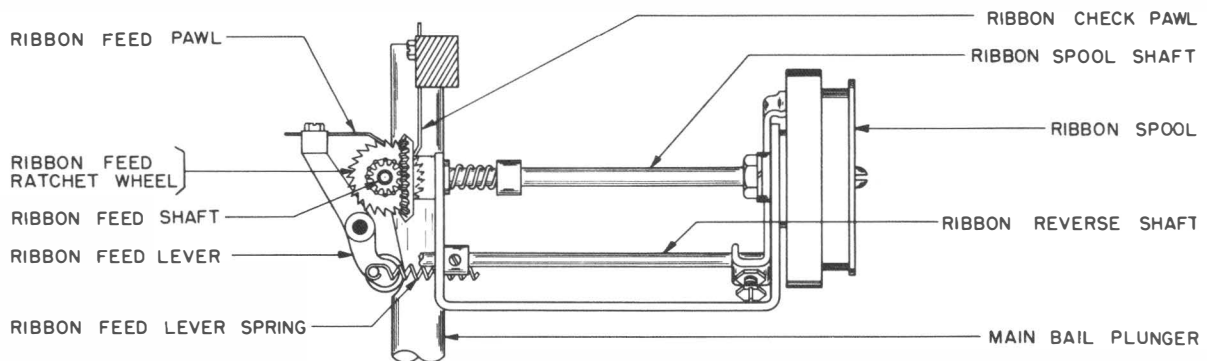

FIGURE 12

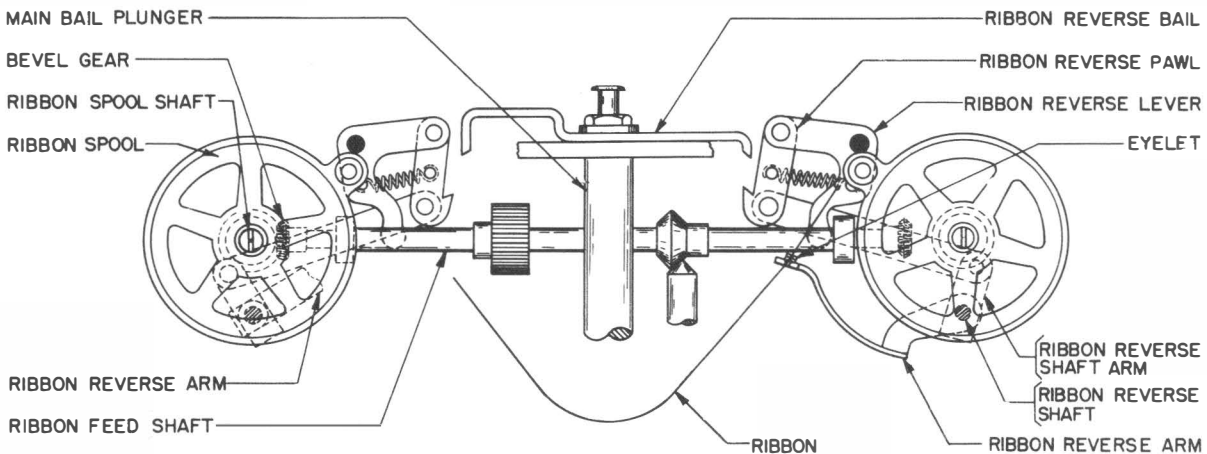

FIGURE 13

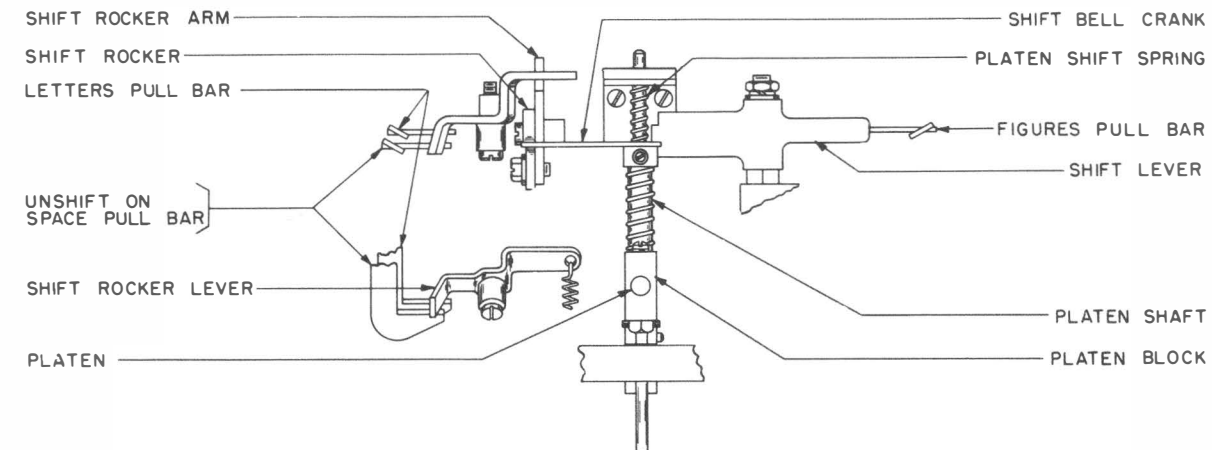

FIGURE 14

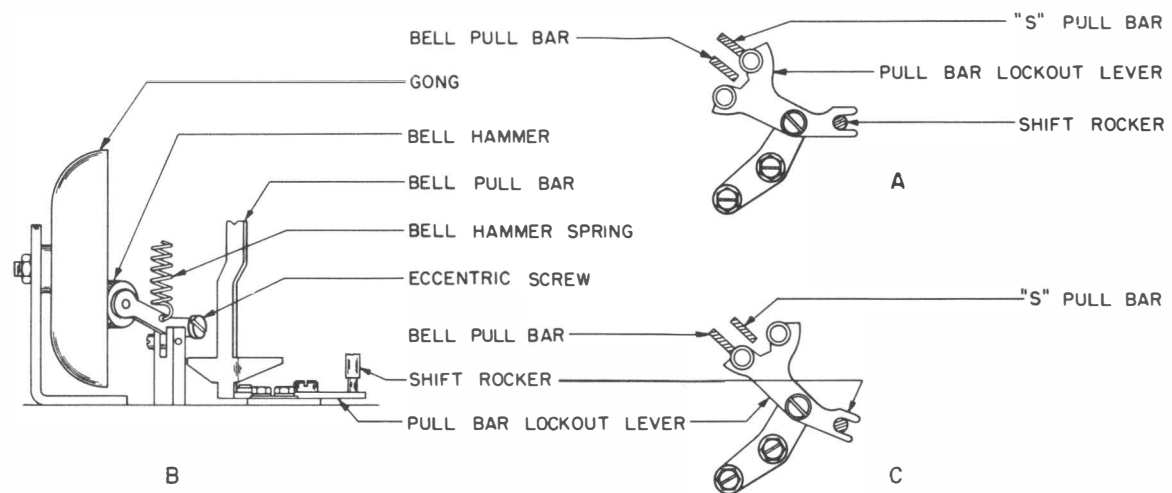

FIGURE 15

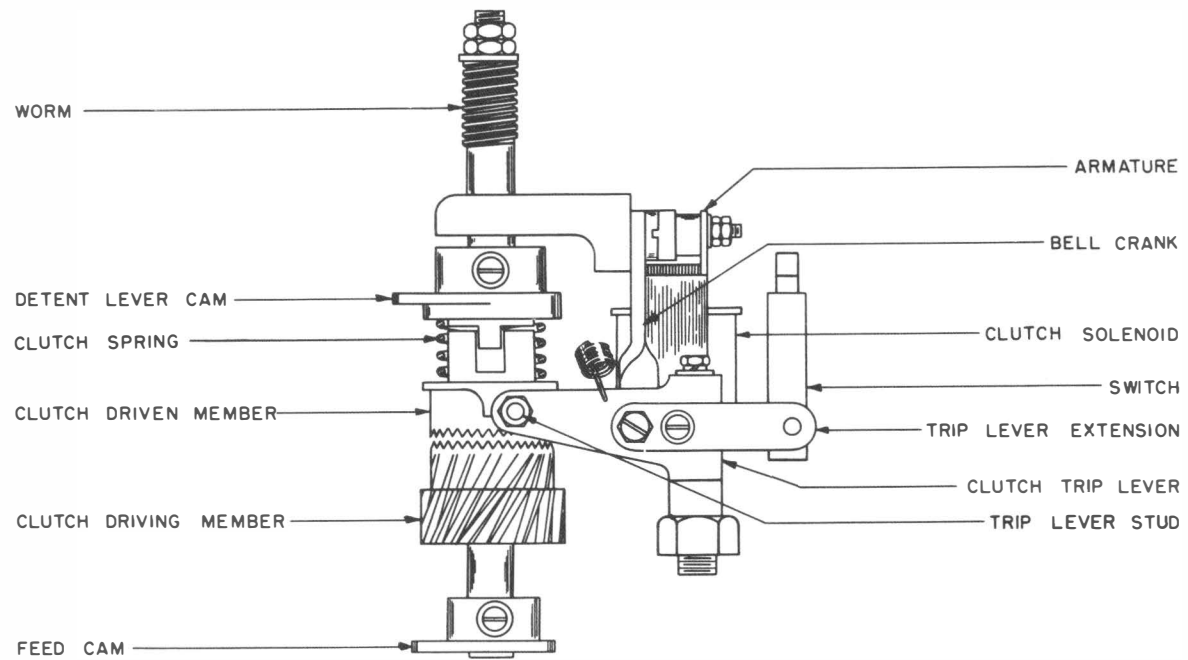

FIGURE 16

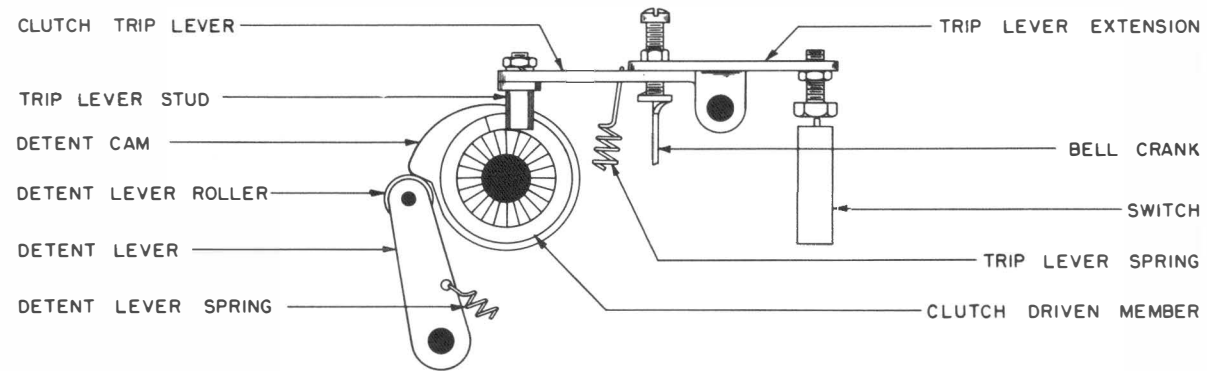

FIGURE 17

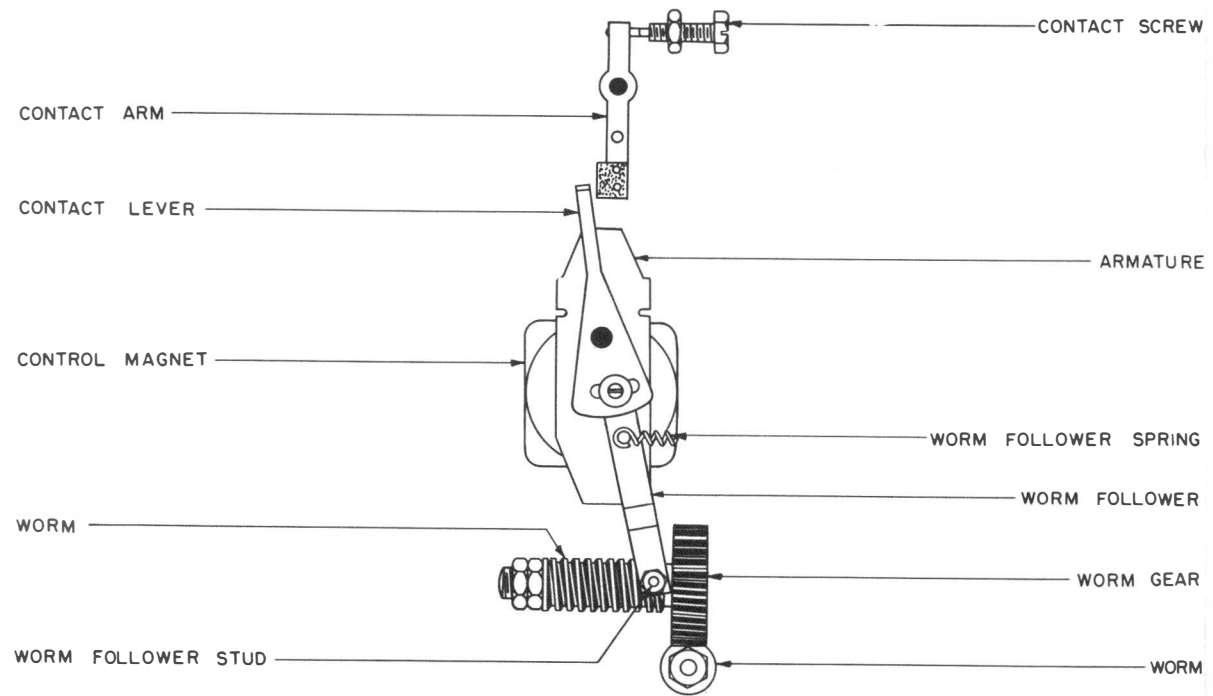

FIGURE 18