

symbol of leadership

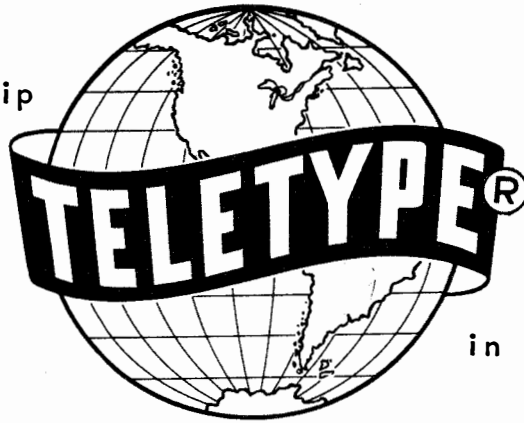

in printing telegraphy

BULLETIN 1147B

PARTS

MOTORS, GOVERNORS
AND ACCESSORIES

(For Model 28 line motors, see
associated apparatus bulletin)

TELETYPE®
CORPORATION
SUBSIDIARY OF *Western Electric Company* INC.
CHICAGO, ILLINOIS, U. S. A.



LIST OF EFFECTIVE PAGES

June, 1960

(Supersedes October, 1952 Issue)

Page Number	Change In Effect
A to B	Change 1
1-1 to 1-6	Change 1
2-1 to 2-10	Change 1
3-1 to 3-7	Change 1
4-1 to 4-6	Change 1

The above list indicates the effective pages as of the date of issue. Upon receipt of Change Pages, insert them numerically and discard any superseded pages.

TABLE OF CONTENTS

	Page Number
SECTION 1 - STANDARD MOTORS	
A.C. Synchronous Motors	1-2, 1-3
A.C. Series Motors	1-4
D.C. Shunt Motors	1-5
A.C./D.C. Series Motor	1-6

SECTION 2 - GOVERNORS AND ACCESSORIES

Governor Adjusting Bracket Assembly	2-2
Center Contact Governor Assembly	2-3
Center Contact Governor Assembly (With Fan)	2-4
Two Speed Governor Assembly (With Spots)	2-5
103543 Modification Kit To Equip A Model 15 Printer A.C. Governed Motor With A Two Speed Governor	2-6
103544 Modification Kit To Equip A Model 15 Printer D.C. Governed Motor With A Two Speed Governor	2-6
103312 Modification Kit To Equip A Model 14 Printer A.C. Governed Motor With A Two Speed Governor	2-7
103313 Modification Kit To Equip A Model 14 Printer D.C. Governed Motor With A Two Speed Governor	2-7
Peripheral Contact Type Governor	2-8
Targets And Tuning Forks	2-9
136132 Modification Kit To Equip The 82283 Synchronous Motor With Overload Protection	2-10
136035 Modification Kit To Provide An Improved Starting Winding Cut-Out Switch For A 60 Cycle Holtzer-Cabot Synchronous Motor	2-10
136036 Modification Kit To Provide An Improved Starting Winding Cut-Out Switch For A 50 Or 25 Cycle Holtzer-Cabot Synchronous Motor	2-10
Lamp And Switch Assembly	2-10

SECTION 3 - OLD STYLE MOTORS

Replacement Chart for Discontinued Motors	3-2
A.C. Synchronous Motor	3-3
A.C. Series Motors	3-4
D.C. Shunt Motors	3-5
A.C. Series Motors	3-6
A.C. Synchronous Motor	3-7
Old Style Cut-Out Switches For Holtzer-Cabot Synchronous Motors	3-7

SECTION 4 - NOTES & NUMERICAL INDEX

Notes of Explanation	4-2
Numerical Index	4-3, 4-4, 4-5, 4-6

This bulletin supersedes Correction Sheets 480EE, 506EE and 650EE, and supplements the following bulletins:

1028B	1041B	1079B	1087B	1103B	1109B	1120B	1130B	1141B
1030B	1051B	1080B	1088B	1104B	1110B	1122B	1131B	1143B
1031B	1063B	1082B	1095B	1106B	1116B	1123B	1132B	1145B
1036B	1064B	1083B	1096B	1107B	1117B	1125B	1137B	1148B
1037B	1072B	1084B	1100B	1108B	1119B	1126B	1140B	

Bell System Only

When ordering parts from this bulletin, prefix each number with the letters TP.

1147B

SECTION 1
STANDARD MOTORS

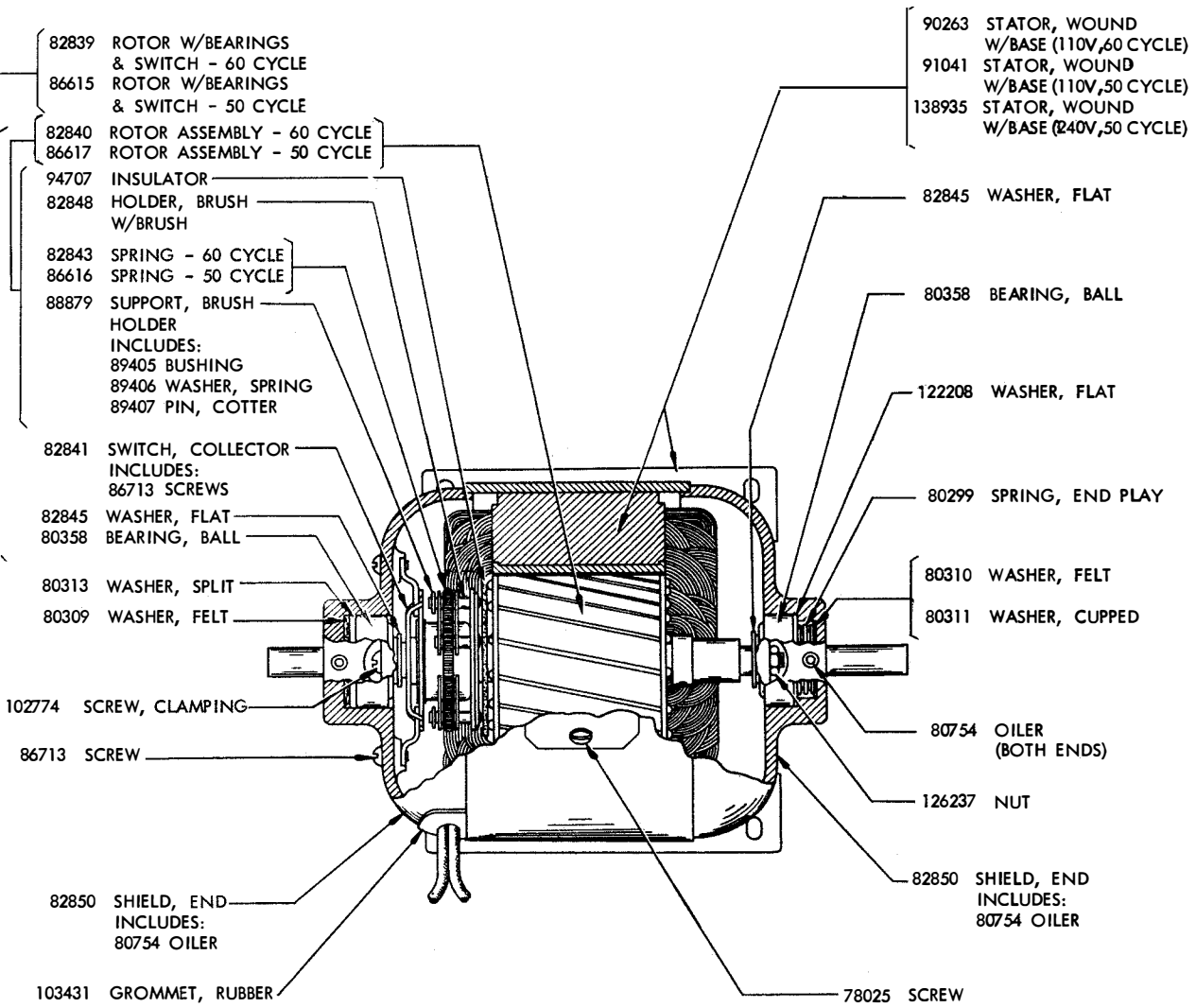

82283 SYNCHRONOUS MOTOR: 1/40 H.P., 110 V., 60 CYCLE, A.C. (G.E. Model 55H25AB11B)
 (NEW STYLE - SEE PAGE 3-3 FOR OLD STYLE)

82714 SYNCHRONOUS MOTOR: 1/40 H.P., 110 V., 50 CYCLE, A.C. (G.E. Model 55H25AB14B)

138809 SYNCHRONOUS MOTOR: 1/40 H.P., 240 V., 50 CYCLE, A.C. (G.E. Model 55H25AB47)

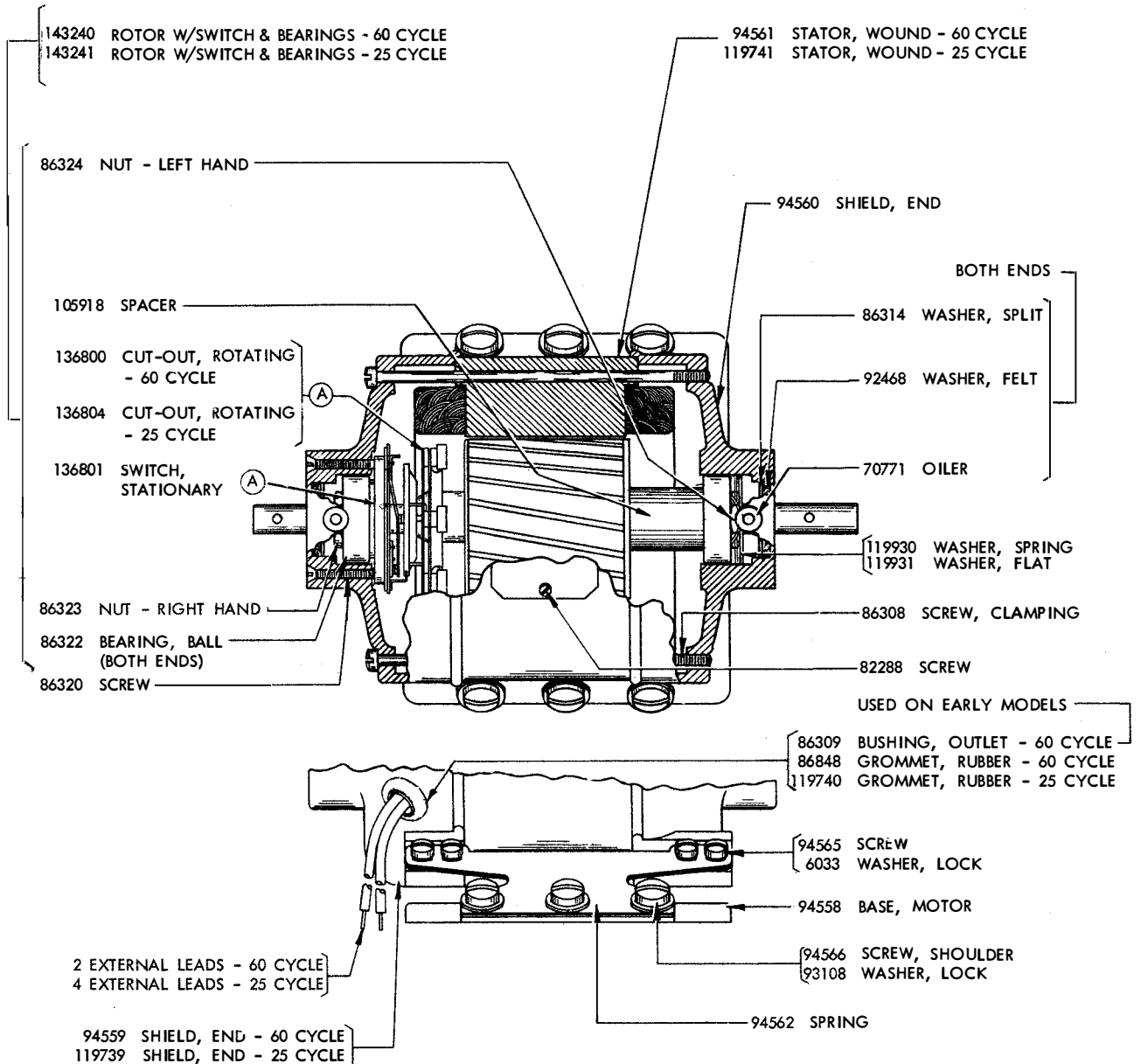

92575 SYNCHRONOUS MOTOR: 1/40 H.P., 115 V., 60 CYCLE, A.C. (H.C. Model S-9017)

114321 SYNCHRONOUS MOTOR: 1/40 H.P., 115 V., 25 CYCLE, A.C. (H.C. Model S-9060)

(WITH NEW STYLE CUT-OUT SWITCHES-SEE PAGE 3-7 FOR OLD STYLE)

(A) For explanation, see page 4-2.

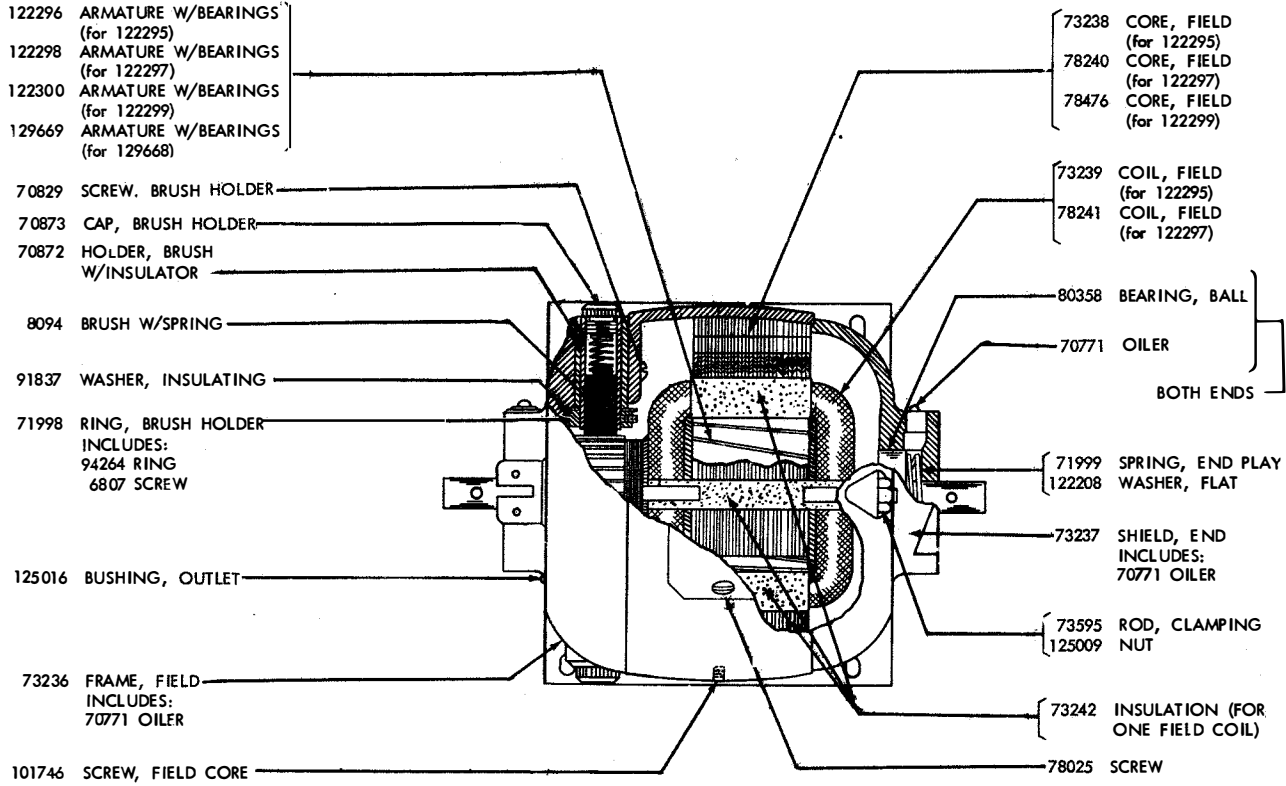

122295 SERIES MOTOR: 1/25 H.P., 110 V., 50/60 CYCLE A.C. (G.E. Model 5BA65AA77A or 5BA65AA179)

122297 SERIES MOTOR: 1/25 H.P., 95/130V., 50/60 CYCLE A.C. (G.E. Model 5BA65AA29A or 5BA65AA178)

122299 SERIES MOTOR: 1/25 H.P., 220 V., 60 CYCLE A.C. (G.E. Model 5BA65AA116A)

129668 SERIES MOTOR: 1/25 H.P., 110 V., 50 CYCLE A.C. (G.E. Model 5BA65AA142A)

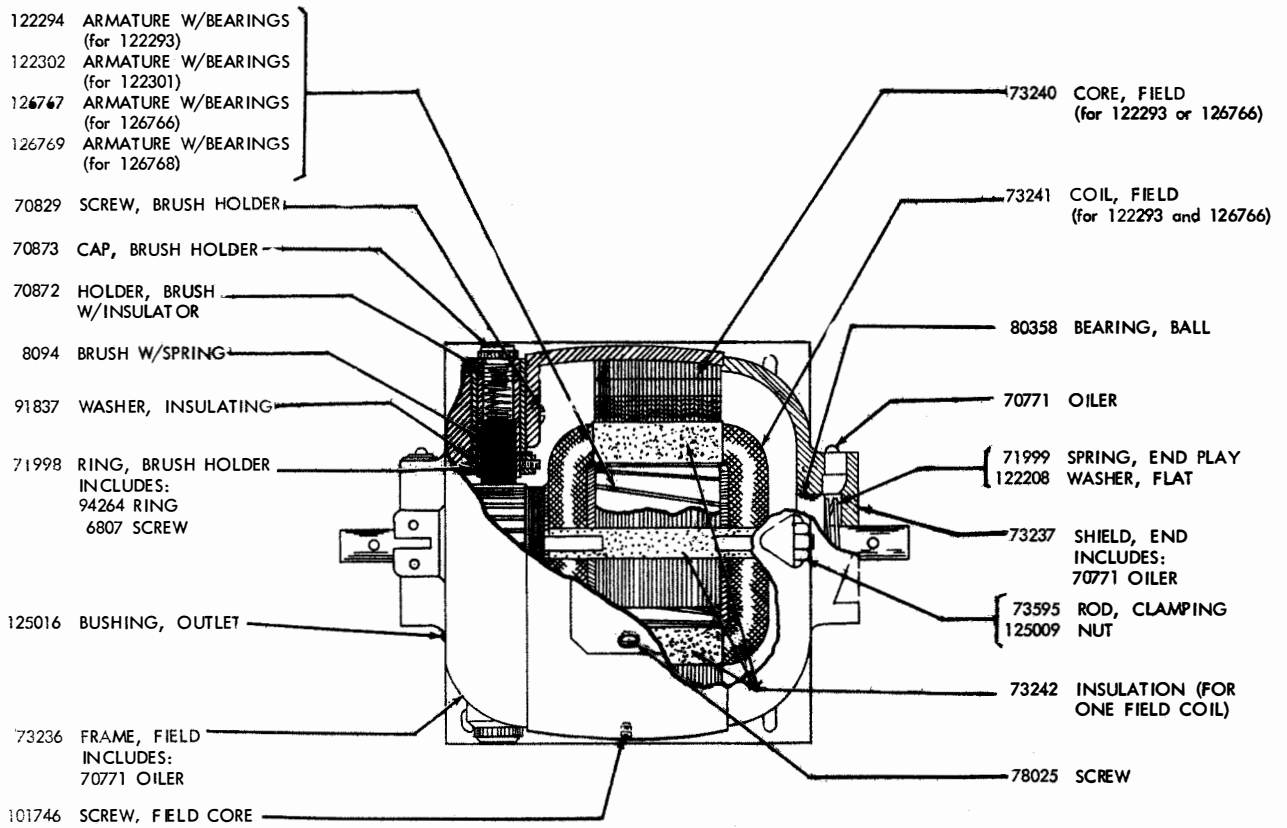

122293 SHUNT MOTOR: 1/17 H.P., 110 V., D.C. (G.E. Model 5BY30A3A or 5BY30A11)

122301 SHUNT MOTOR: 1/17 H.P., 220 V., D.C. (G.E. Model 5BY30A10A)

126766 SHUNT MOTOR: 1/20 H.P., 110 V., D.C. (G.E. Model 5BY30A6A)

126768 SHUNT MOTOR: 1/20 H.P., 220 V., D.C. (G.E. Model 5BY30A7A)

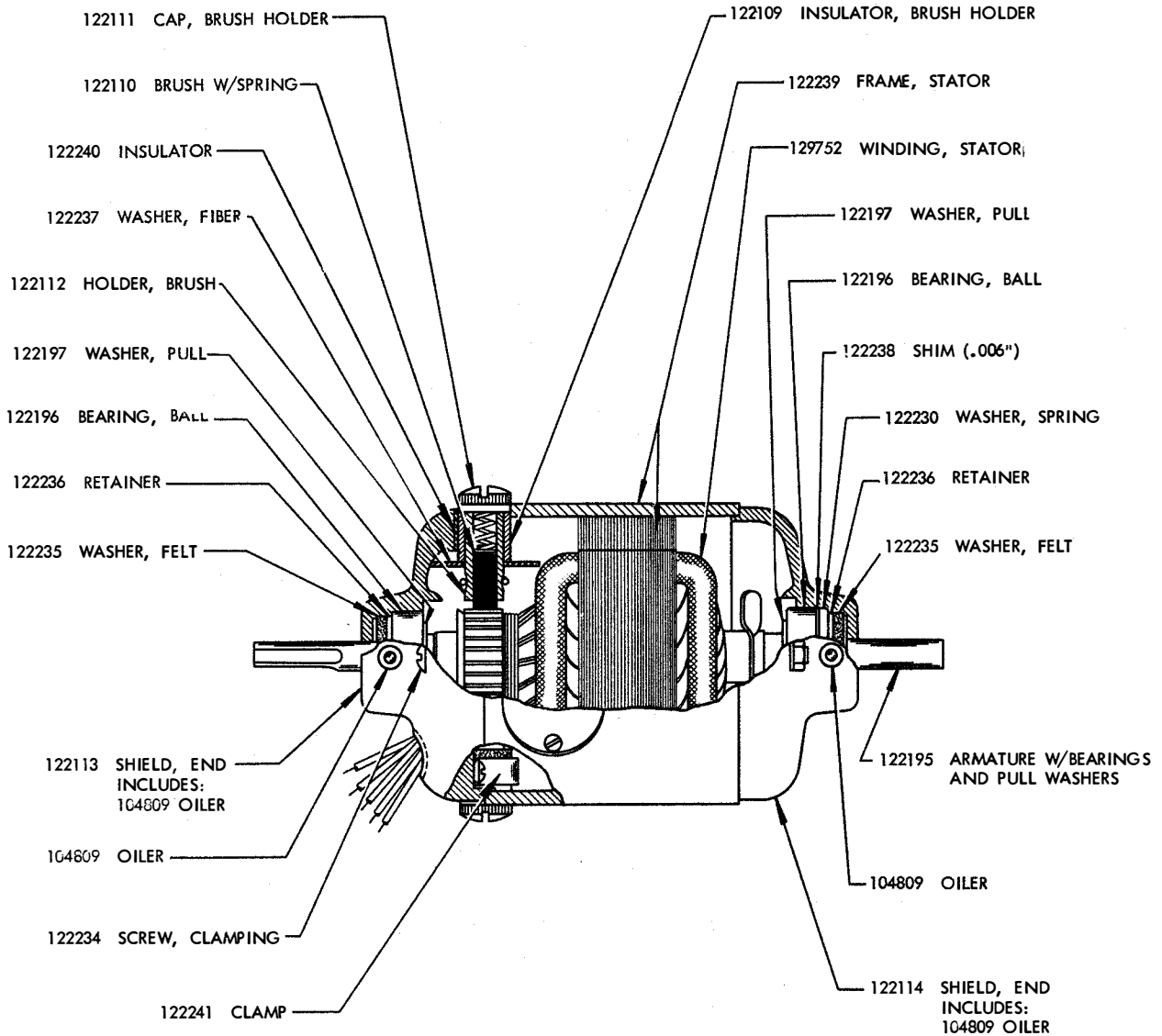

121272 SERIES MOTOR: 1/30 H.P., 115 V., A.C./D.C. (G.E. Model 5P36DA33)

SECTION 2
GOVERNORS AND ACCESSORIES

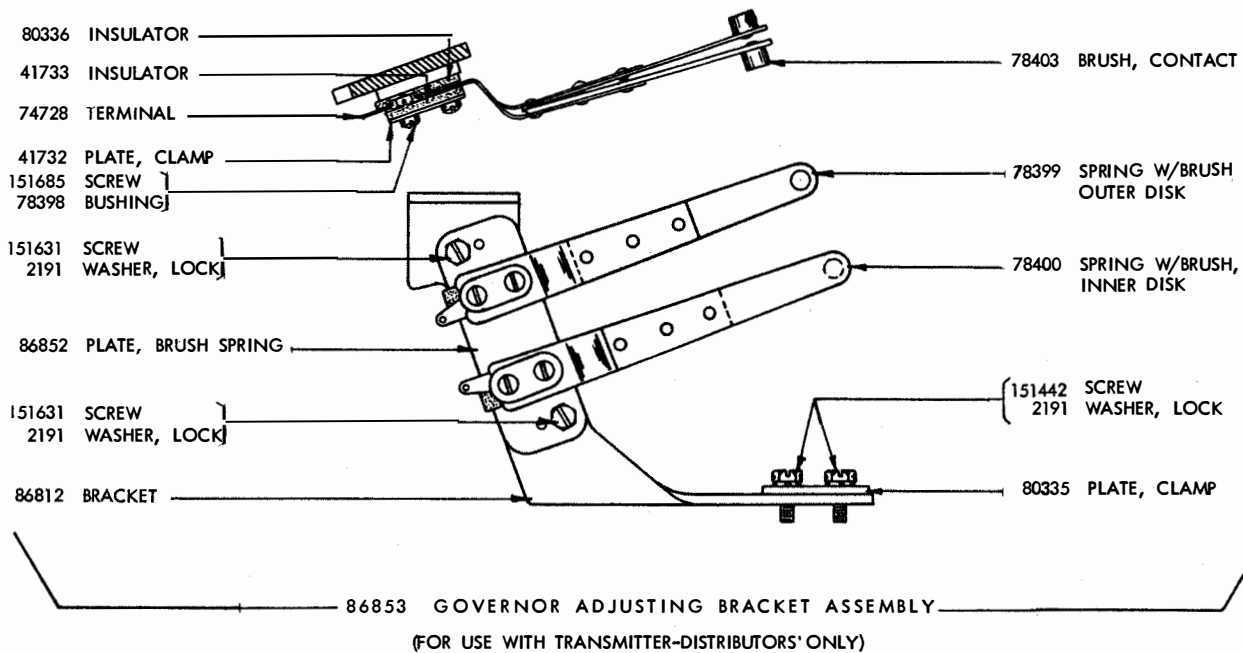
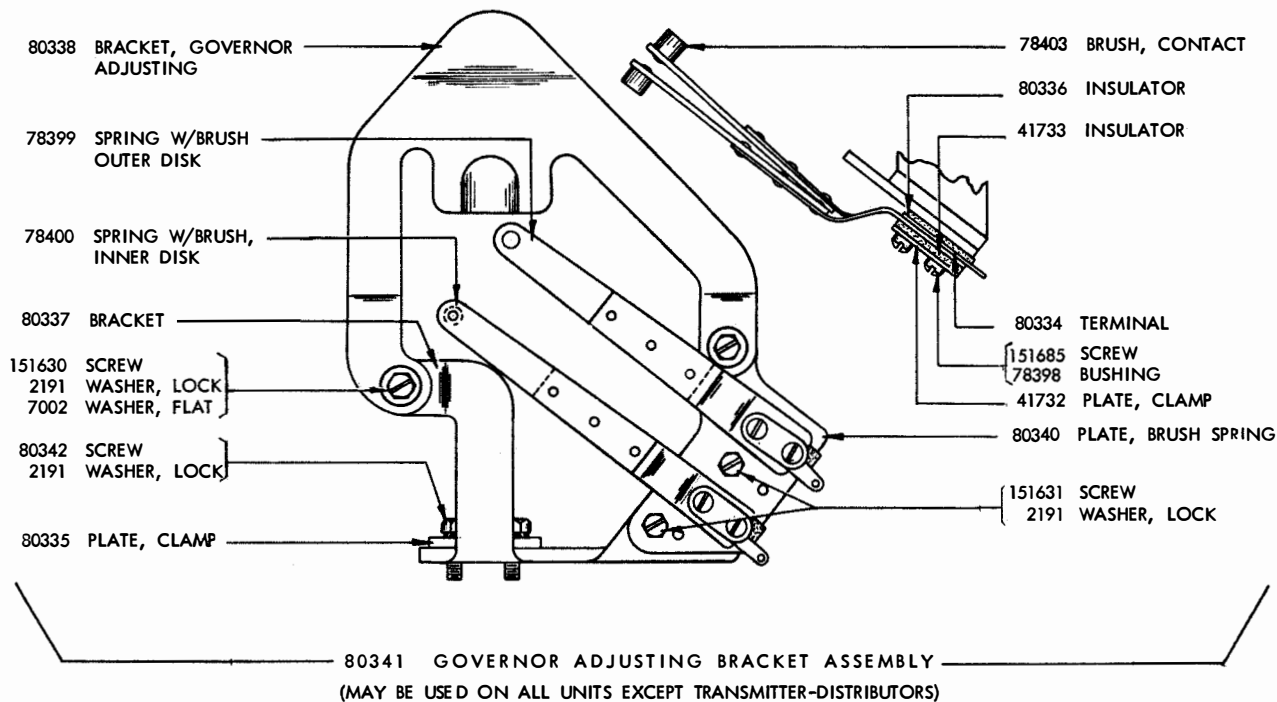

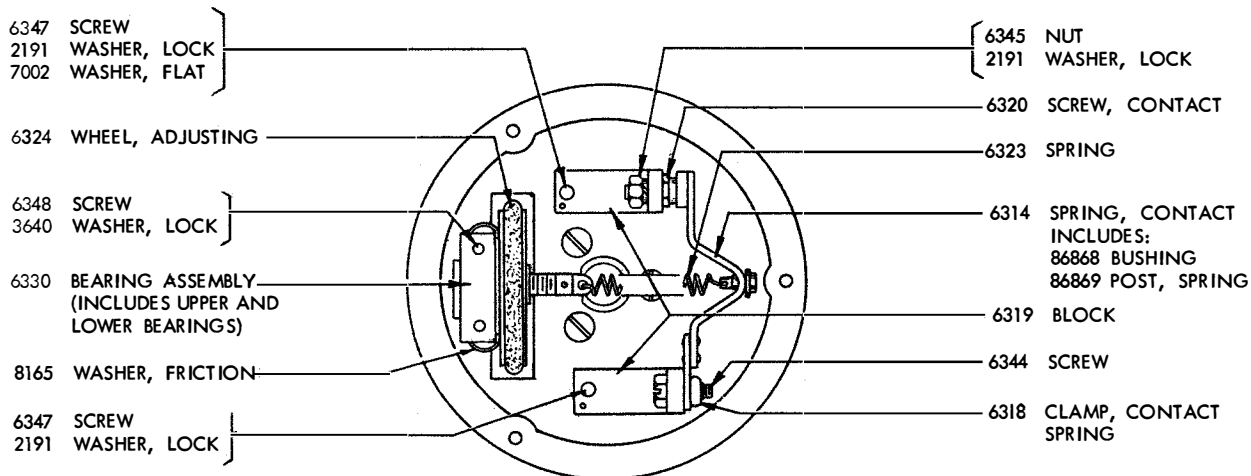
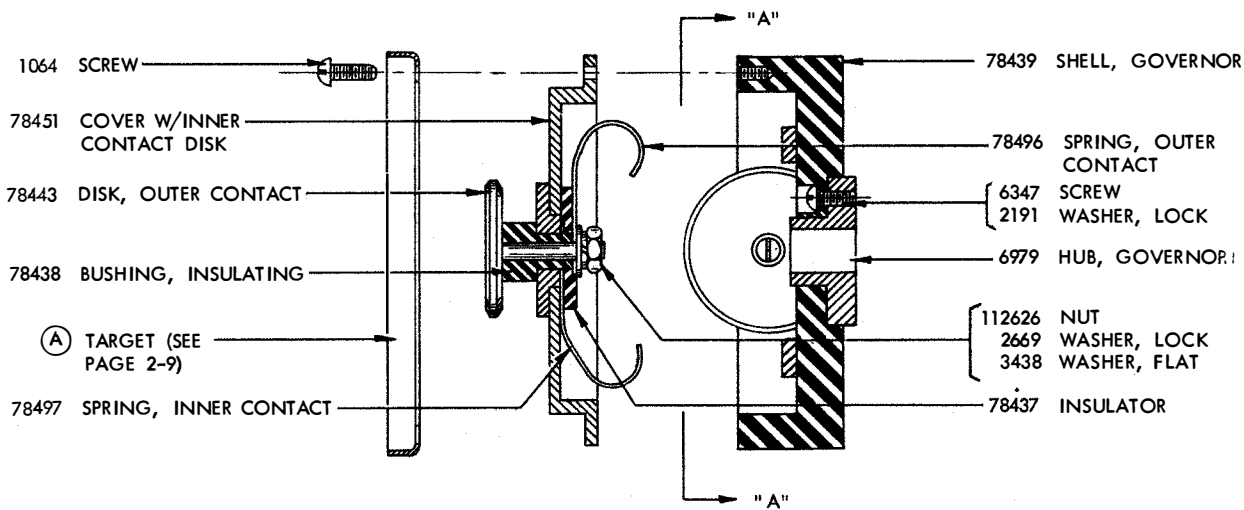
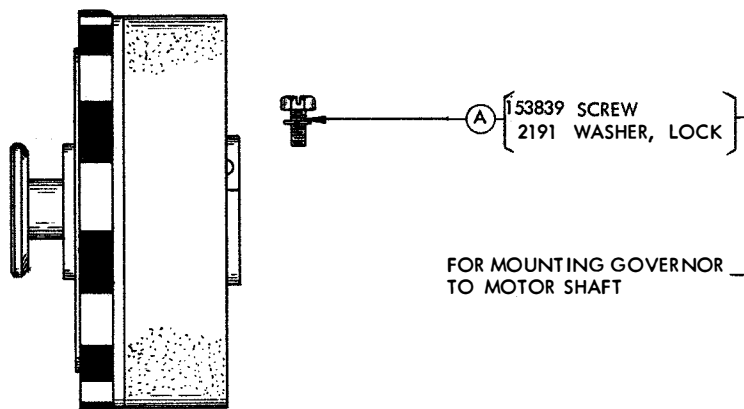

VIEW AT "A - A"

80352 CENTER CONTACT GOVERNOR ASSEMBLY
(EXCLUDES PARTS MARKED (A))

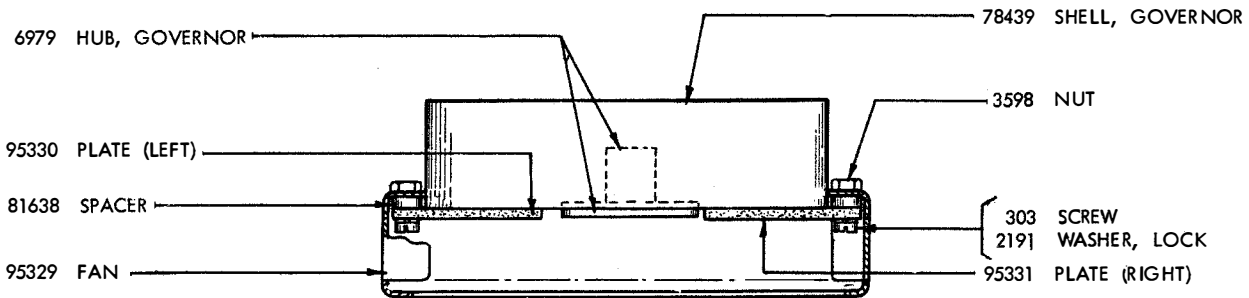
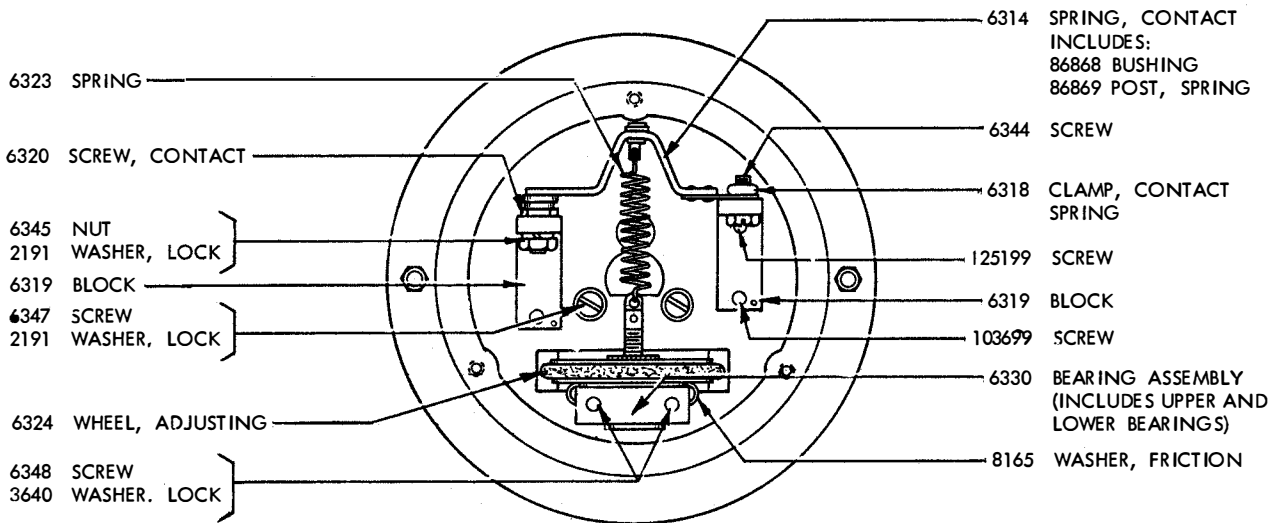
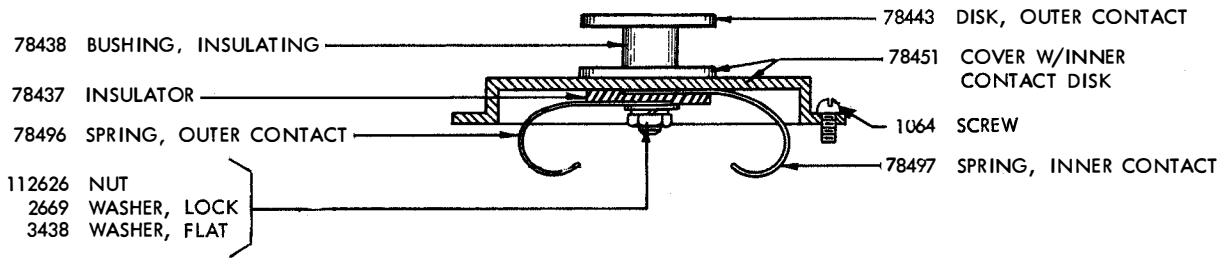

95332 CENTER CONTACT GOVERNOR ASSEMBLY WITH FAN

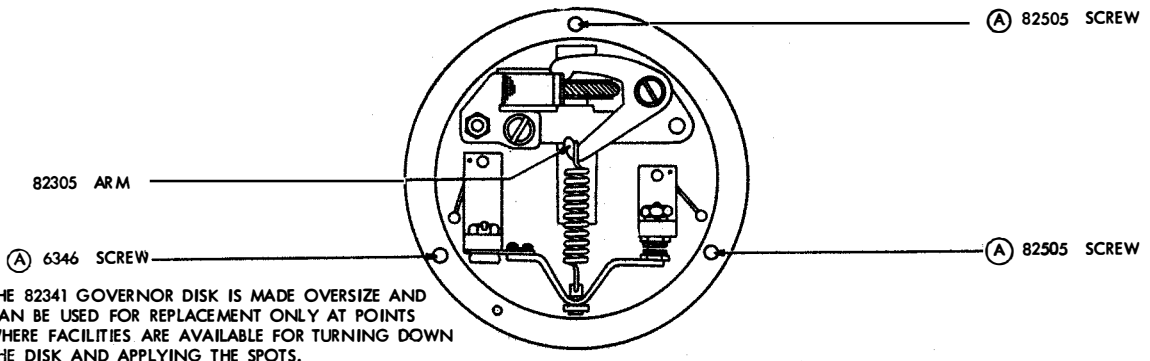
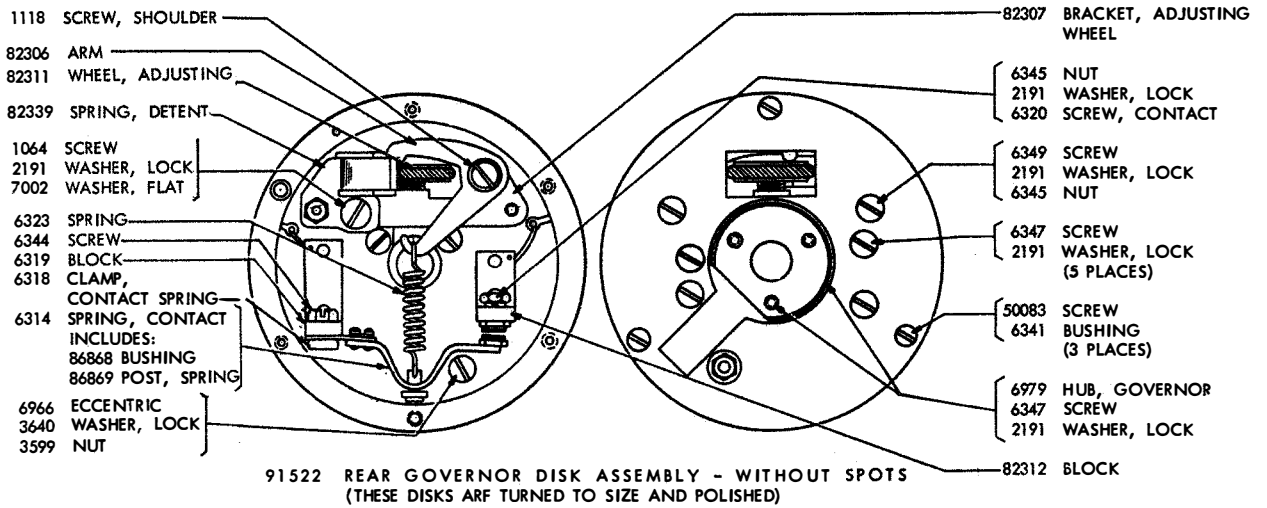

82341 FRONT GOVERNOR DISK ASSEMBLY
 (EXCLUDES PARTS MARKED (A) - PARTS SHOWN BUT NOT LISTED, SAME AS ABOVE)

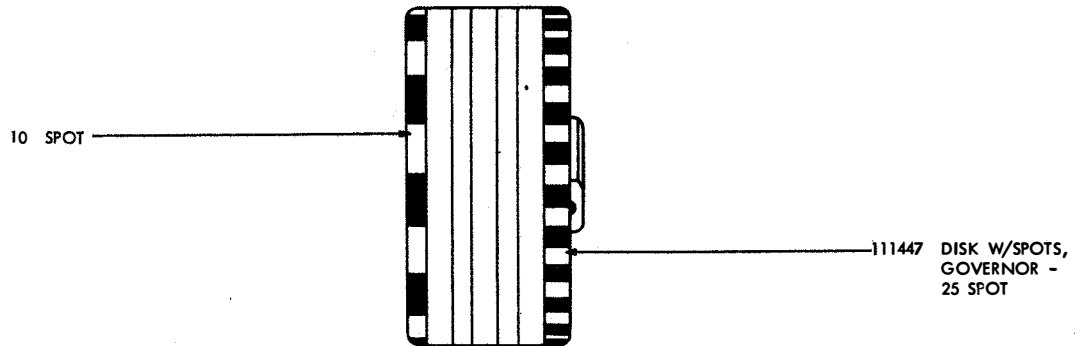

103311 TWO-SPEED GOVERNOR ASSEMBLY - WITH SPOTS
 (INCLUDES ALL PARTS LISTED ABOVE)

82344 SWITCH, TOGGLE (A) (B)
INCLUDES:
91683 NUT, HEX
91684 NUT, RING

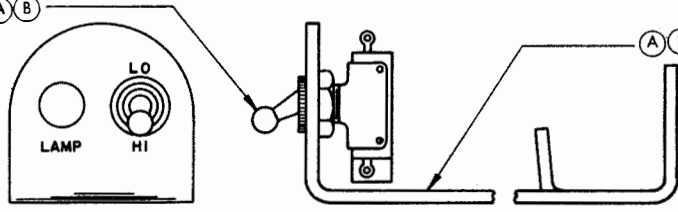

91276 BRACKET (A) (B)

84106 GEAR, WORM (A) (B)
(32T)

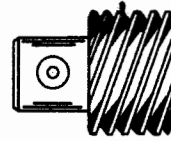
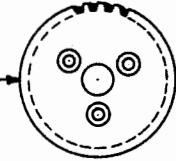

84105 PINION, MOTOR (8T) (A) (B)

82361 HOLDER, BRUSH
153539 SCREW
2191 WASHER, LOCK
6305 BRUSH

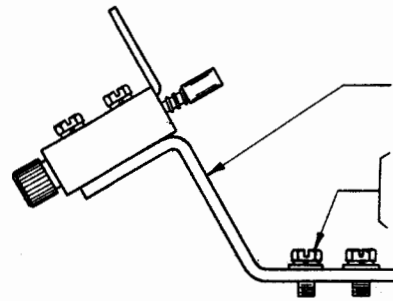
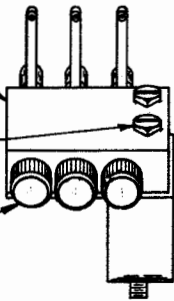

82316 BRACKET, BRUSH HOLDER

151631 SCREW
2191 WASHER, LOCK
7002 WASHER, FLAT

(A) (B) 82005 GOVERNOR BRUSH HOLDER ASSEMBLY

136653 CABLE
90511 SCREW
7002 WASHER, FLAT
2191 WASHER, LOCK
3598 NUT
82361 HOLDER, BRUSH
6305 BRUSH
136652 BRACKET
80342 SCREW
2191 WASHER, LOCK
7002 WASHER, FLAT

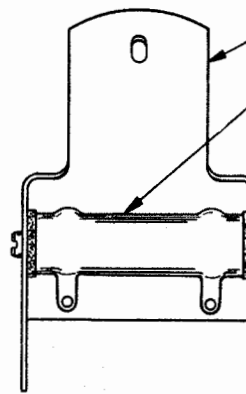
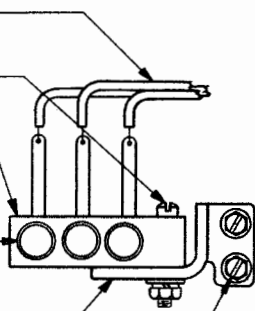

(B) 91506 BRACKET
(B) 95222 RESISTOR (40 OHMS)

(B) 1297 SCREW
89969 WASHER, INSULATING
7002 WASHER, FLAT
3598 NUT

SPECIFICATION 53325

(A) 92721 CABLE - A.C. (1755WD)

(B) 91275 CABLE - D.C. (1815WD)

(A) (B) 138598 AUXILIARY BRUSH HOLDER ASSEMBLY

103543 MODIFICATION KIT TO EQUIP A MODEL 15 PRINTER A.C. GOVERNED MOTOR WITH A TWO-SPEED GOVERNOR FOR 368 AND 460 O. P. M.
(INCLUDES ALL PARTS MARKED (A) ON THIS PAGE AND THE 103311 GOVERNOR ASSEMBLY SHOWN ON PAGE 2-5)

103544 MODIFICATION KIT TO EQUIP A MODEL 15 PRINTER D.C. GOVERNED MOTOR WITH A TWO-SPEED GOVERNOR FOR 368 AND 460 O. P. M.
(INCLUDES ALL PARTS MARKED (B) ON THIS PAGE AND THE 103311 GOVERNOR ASSEMBLY SHOWN ON PAGE 2-5)

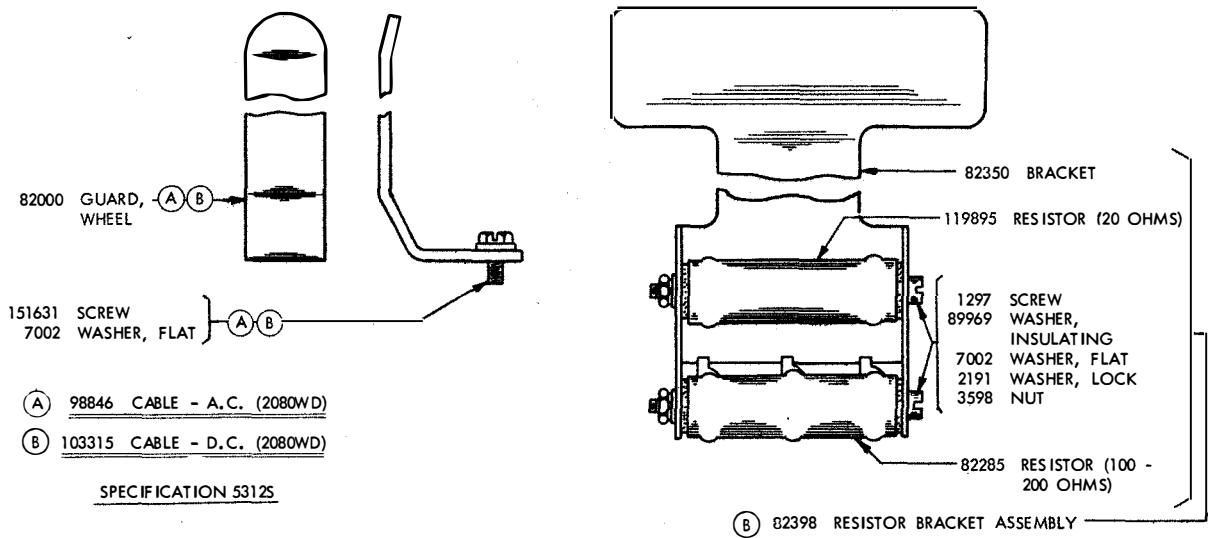
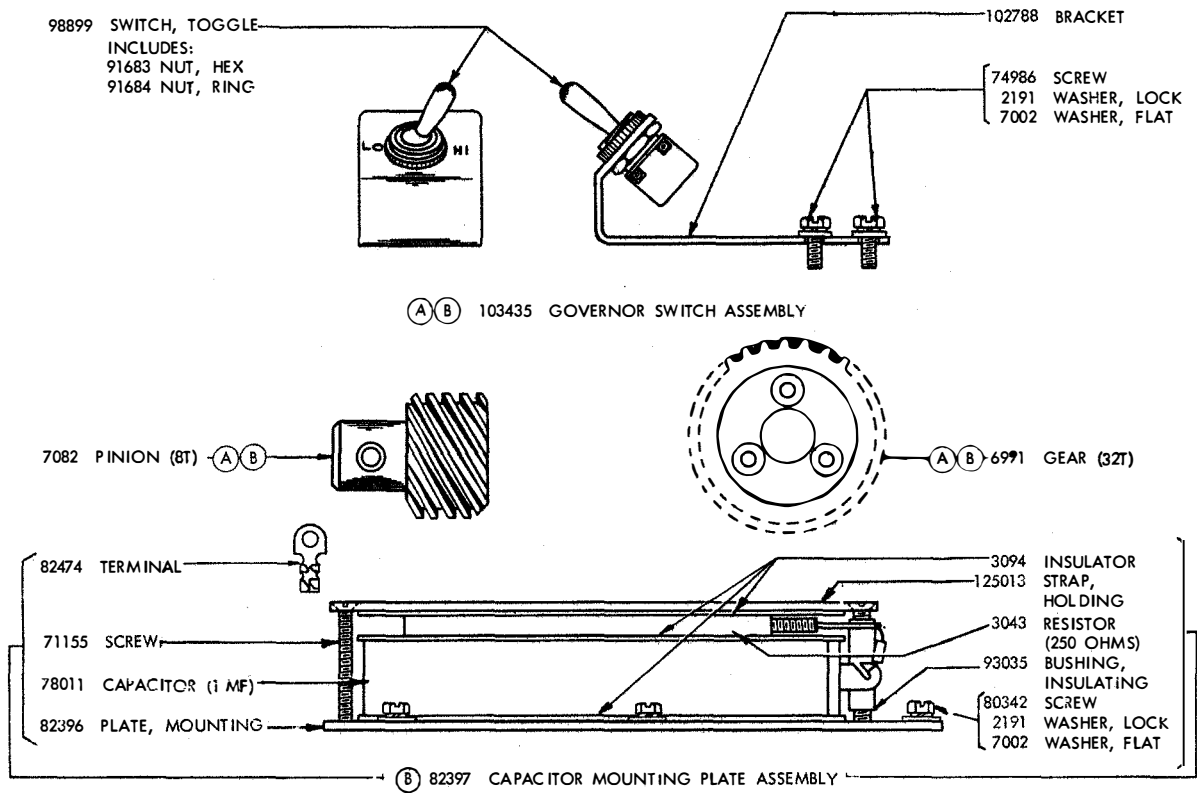

103312 MODIFICATION KIT TO EQUIP A MODEL 14 PRINTER A.C. GOVERNOR MOTOR WITH A TWO-SPEED GOVERNOR FOR 368 AND 460 O.P.M. (INCLUDES ALL PARTS MARKED (A), THE 103311 GOVERNOR ASSEMBLY - PAGE 2-5, THE 82005 AND THE 138598 GOVERNOR BRUSH HOLDER ASSEMBLIES - PAGE 2-6)

103313 MODIFICATION KIT TO EQUIP A MODEL 14 PRINTER D.C. GOVERNOR MOTOR WITH A TWO-SPEED GOVERNOR FOR 368 AND 460 O.P.M. (INCLUDES ALL PARTS MARKED (B), THE 103311 GOVERNOR ASSEMBLY - PAGE 2-5, THE 82005 AND THE 138598 GOVERNOR BRUSH HOLDER ASSEMBLIES - PAGE 2-6)

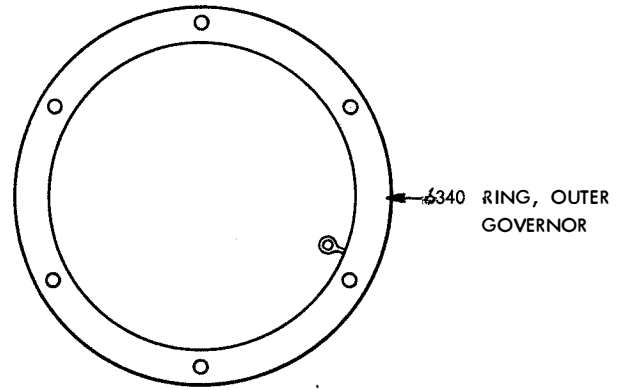
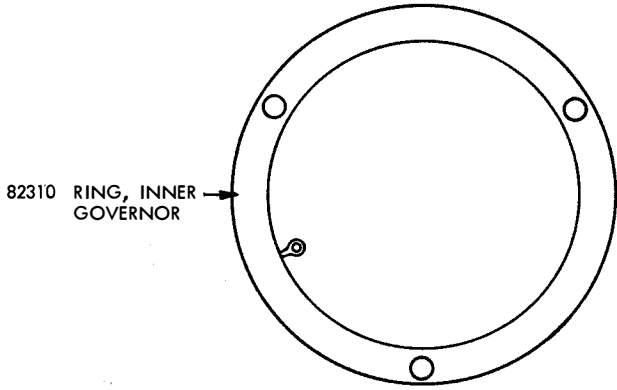
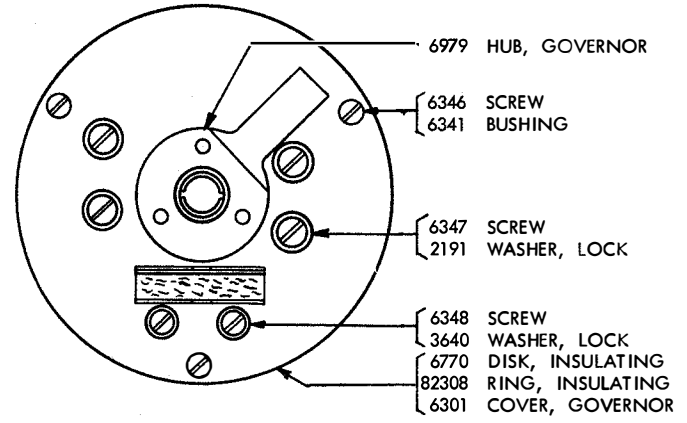
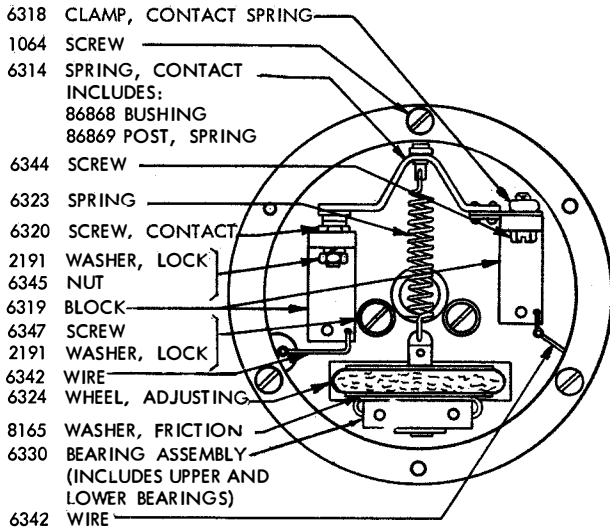

THESE GOVERNOR RINGS ARE MADE OVERSIZED AND CAN BE USED FOR REPLACEMENT ONLY AT POINTS WHERE FACILITIES ARE AVAILABLE FOR TURNING THEM DOWN AFTER RINGS HAVE BEEN ASSEMBLED IN GOVERNOR.

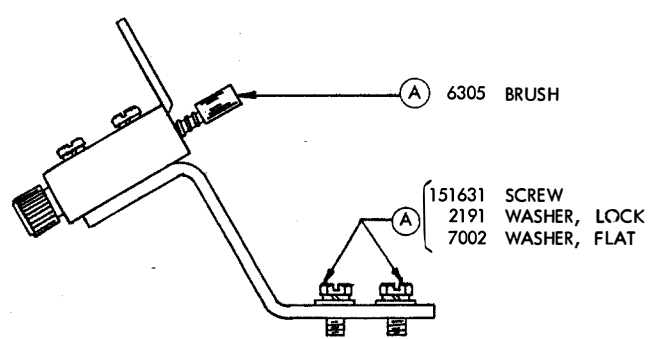
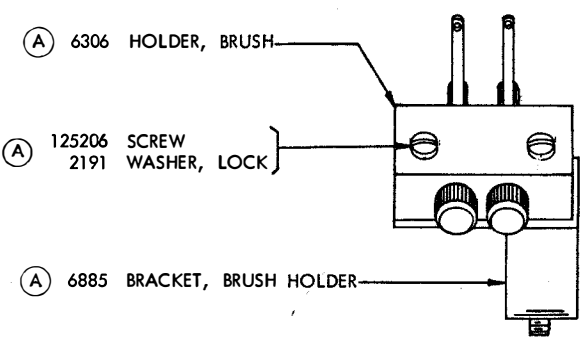

7485 PERIPHERAL CONTACT TYPE GOVERNOR

(EXCLUDES PARTS MARKED (A))

1147B

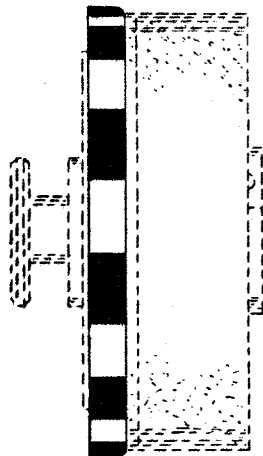

876
876

TARGETS

NO OF SPOTS	PART NUMBER	BELL CODE
5	73376	
6	73377	
7	8425	
8	7704	
9	7705	
10	7105	1G
11	7106	1H
13	7107	1B
23	72665	1J
35	93903	

2102 RPN
1600 RPN

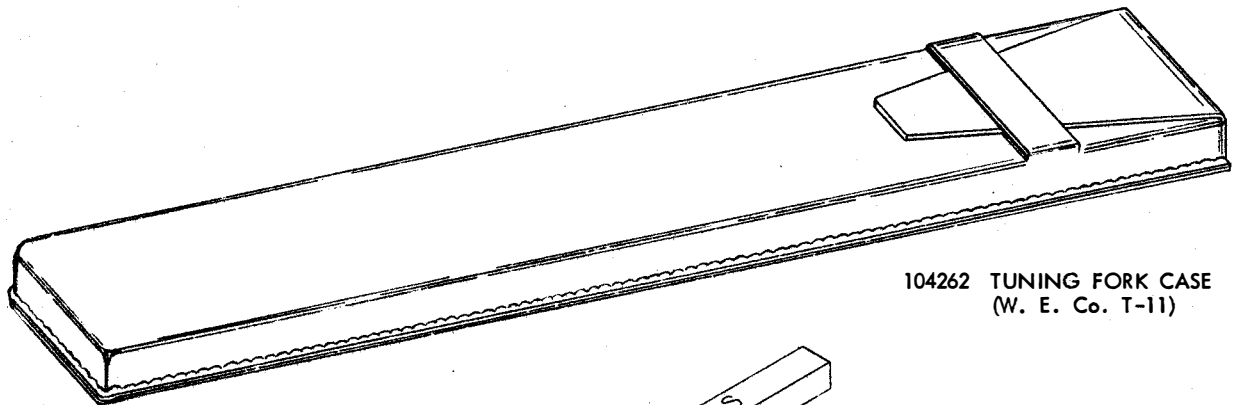

104262 TUNING FORK CASE
(W. E. Co. T-11)

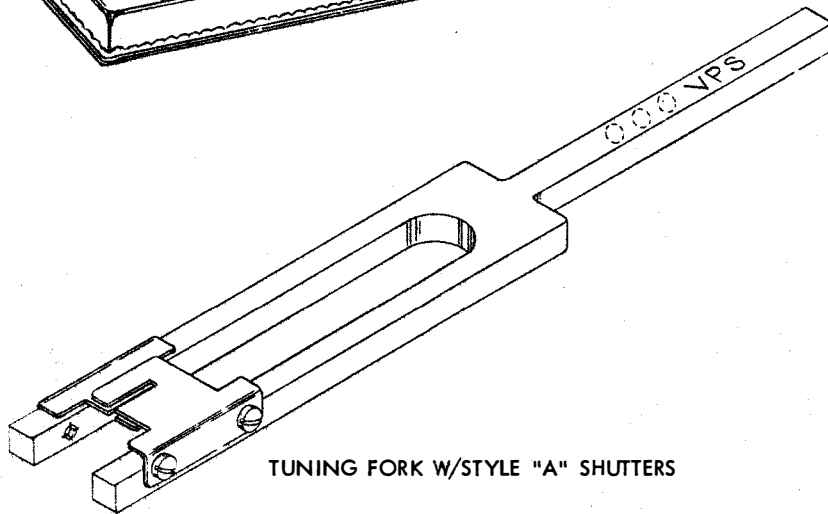

TUNING FORK W/STYLE "A" SHUTTERS

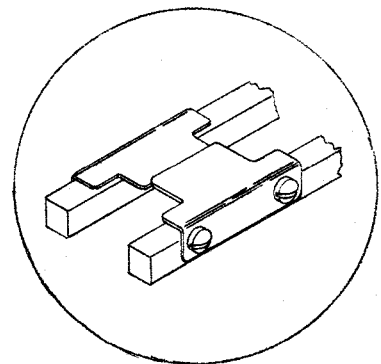

STYLE "B" SHUTTERS

TUNING FORKS

VIBRATIONS PER SECOND (VPS)	PART NUMBER	SHUTTER STYLE	OVERALL LENGTH	VIBRATIONS PER SECOND (VPS)	PART NUMBER	SHUTTER STYLE	OVERALL LENGTH
87.6	*103628	A	11.063	123.5	104988	B	9.813
90.46	104983	A	10.843	124.5	104987	A	9.781
96.19	104984	A	10.690	125	114755	A	9.682
100	104985	A	10.533	126.4	114759	A	9.651
102	114756	A	10.453	127.3	104981	A	9.625
116	114758	A	10.000	128	104982	A	9.600
120	104986	A	9.875	139.29	114757	A	9.281
121.7	104980	A	9.813	168	104748	B	8.843
122.7	114754	A	9.813				

*Bell System Standard

TARGETS AND TUNING FORKS

1147B

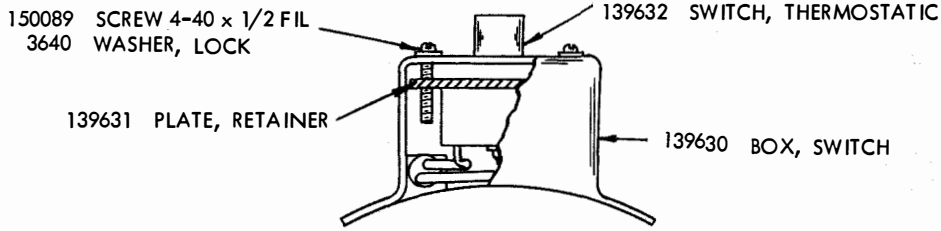

AT BACK OF THIS REV. → 59045 SPECIFICATION

136132 MODIFICATION KIT TO EQUIP THE 82283 SYNCHRONOUS MOTOR WITH OVERLOAD PROTECTION

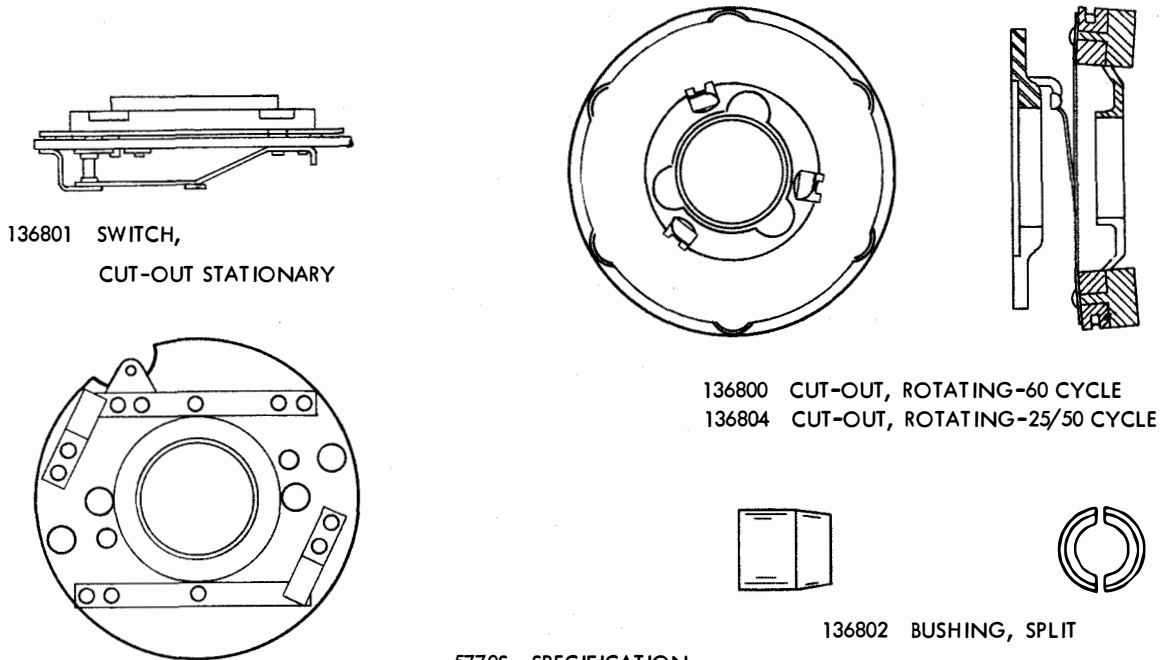

57705 SPECIFICATION

136035 MODIFICATION KIT TO PROVIDE AN IMPROVED STARTING WINDING CUT-OUT SWITCH FOR A 60 CYCLE HOLTZER-CABOT SYNCHRONOUS MOTOR
136036 MODIFICATION KIT TO PROVIDE AN IMPROVED STARTING WINDING CUT-OUT SWITCH FOR A 50 OR 25 CYCLE HOLTZER-CABOT SYNCHRONOUS MOTOR

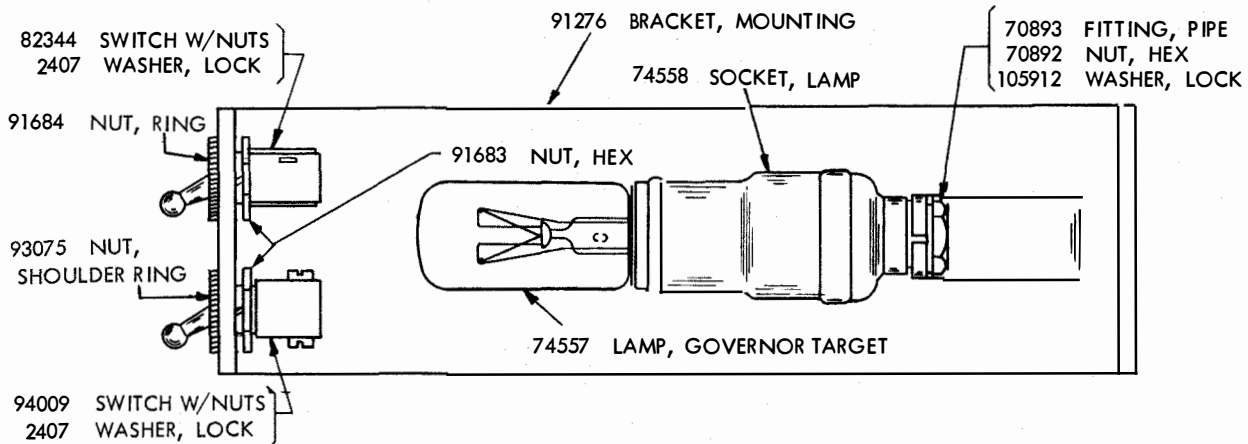

139381 LAMP AND SWITCH ASSEMBLY

1147B

SECTION 3
OLD STYLE MOTORS

Standard Replacements For Discontinued Motors					
Discontinued Motor No.	Page	Mfg. & Model No.	Description	Replacement Motor No.	Page
***74931	-	G.E. 39078 G.E. 5SH25AB1	1/40 H.P., 110V., 60 Cycle, A.C. Synchronous	82283	1-2
***78217	-	G.E. 37233	1/50 H.P., 110V., 60 Cycle, A.C. Synchronous		
***80553	-	G.E. 38367 G.E. 5SH25AB21 G.E. 5SH25AB2	1/50 H.P., 110V., 60 Cycle, A.C. Synchronous		
***82622	-	G.E. 5SH25AB7	1/40 H.P., 110V., 60 Cycle, A.C. Synchronous		
**83799	3-7	H.C. S-9005	1/40 H.P., 115V., 60 Cycle, A.C. Synchronous		
**104061	3-7	H.C. S-9049	1/40 H.P., 115V., 50 Cycle, A.C. Synchronous		
*6708	3-4	G.E. 28478 G.E. 5BA65AA77	1/25 H.P., 110V., 50/60 Cycle, A.C. Series	122295	1-4
***107151	-	E.S. S-9058	1/25 H.P., 110V., 50/60 Cycle, A.C. Series		
*77953	3-4	G.E. 32989 G.E. 5BA65AA29	1/25 H.P., 110V., 60 Cycle, A.C. Series	122297	1-4
**104038	3-6	H.C. S-9050	1/25 H.P., 115V., 50/60 Cycle A.C. Series		
***106875	-	E.S. S-9057	1/25 H.P., 115V., 50/60 Cycle, A.C. Series		
*70735	3-4	G.E. 31810 G.E. 5BA65AA116	1/25 H.P., 220V., 60 Cycle, A.C. Series	122299	1-4
*103501	3-4	G.E. 5BA65AA142	1/25 H.P., 110V., 50 Cycle, A.C. Series		
***116402		JOHN OSTER	115V., A.C./D.C. Series	#121335	1-6
*6707	3-5	G.E. 28479 G.E. 5BY30A6	1/20 H.P., 110V., D.C. Shunt	126766	1-5
*8280	3-5	G.E. 31382 G.E. 5BY30A7	1/20 H.P., 220V., D.C. Shunt		
*72586	3-5	G.E. 31531 G.E. 5BY30A3	1/17 H.P., 110V., D.C. Shunt	122293	1-5
*73644	3-5	G.E. 33373 G.E. 5BY30A10	1/17 H.P., 220V., D.C. Shunt		
**71610	3-5	G.E. 31661 G.E. 5BY30A9	1/17 H.P., 12V., D.C. Shunt	None	-

NOTES:

An order for a discontinued motor will be filled with the standard replacement motor as indicated above.

*No longer manufactured but similar to the replacing motor with the exception of the armature and ball bearings. See note for pages 3-4, 3-5 on page 4-2.

**Obsolete - Maintenance parts to be supplied so long as they are available.

***Obsolete - No replacement parts available.

#An order for the 116402 John Oster motor will be filled with a 121335 Modification Kit which includes the 121272 General Electric motor and the necessary mounting parts. (Specification 5644S)

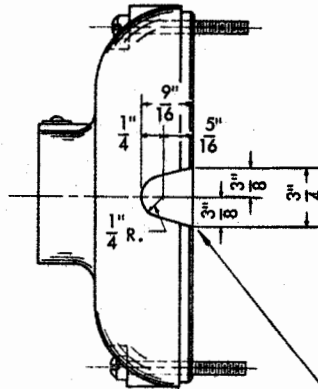

OLD STYLE 82850 END SHIELDS MAY BE WORKED OVER FOR USE WITH NEW STYLE MOTORS BY ADDING WIRE OUTLET HOLE AS ILLUSTRATED.

THE 82850 END SHIELD HAS BEEN REDESIGNED BUT RETAINS ITS ORIGINAL NUMBER. THE NEW STYLE END SHIELD (WITH WIRE OUTLET HOLE) CAN ALSO BE USED ON OLD STYLE MOTORS. THE OLD STYLE END SHIELD (WITHOUT WIRE OUTLET HOLE) CANNOT BE USED ON THE NEW STYLE MOTORS UNLESS IT BE WORKED OVER AS ILLUSTRATED.

THE 90263 WOUND STATOR W/BASE HAS BEEN REDESIGNED BUT RETAINS ITS ORIGINAL NUMBER. WHEN REPLACING AN OLD STYLE STATOR (WITH TAPPED HOLES FOR THE END SHIELD CLAMPING SCREWS) WITH A NEW STYLE STATOR (WITH BODY HOLES FOR THE END SHIELD CLAMPING SCREWS) THE FOLLOWING NEW STYLE PARTS SHOULD BE ORDERED:

- 90263 STATOR W/BASE, WOUND
- 82850 SHIELD, END (OR WORK OVER OLD STYLE END SHIELD)
- 103431 GROMMET, RUBBER
- 102774 SCREW, CLAMPING
- 126237 NUT

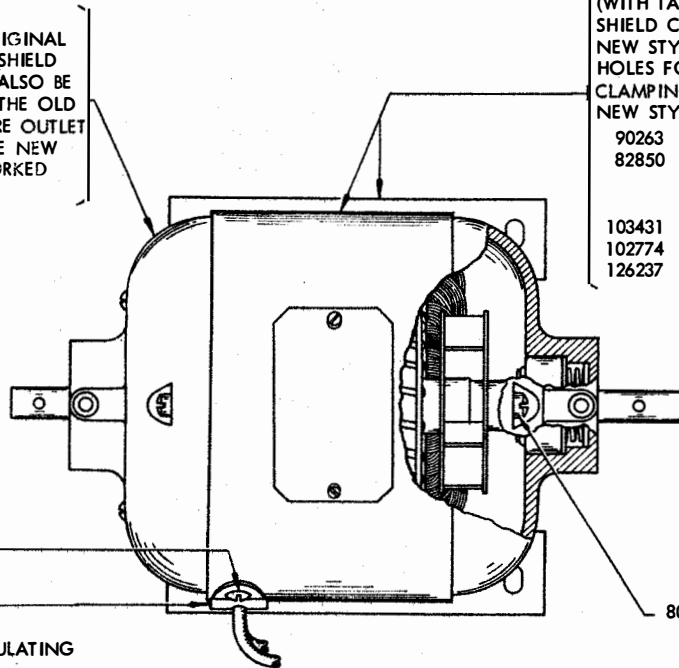

80351 SCREW

80307 OUTLET INCLUDES:
80308 BUSHING, INSULATING

80559 SCREW, CLAMPING

82283 SYNCHRONOUS MOTOR: 1/40 H.P., 110 V., 60 CYCLE A.C. (G.E. Model 55H25AB11)

(OLD STYLE - PARTS NOT LISTED SAME AS THOSE SHOWN ON PAGE 1-2)

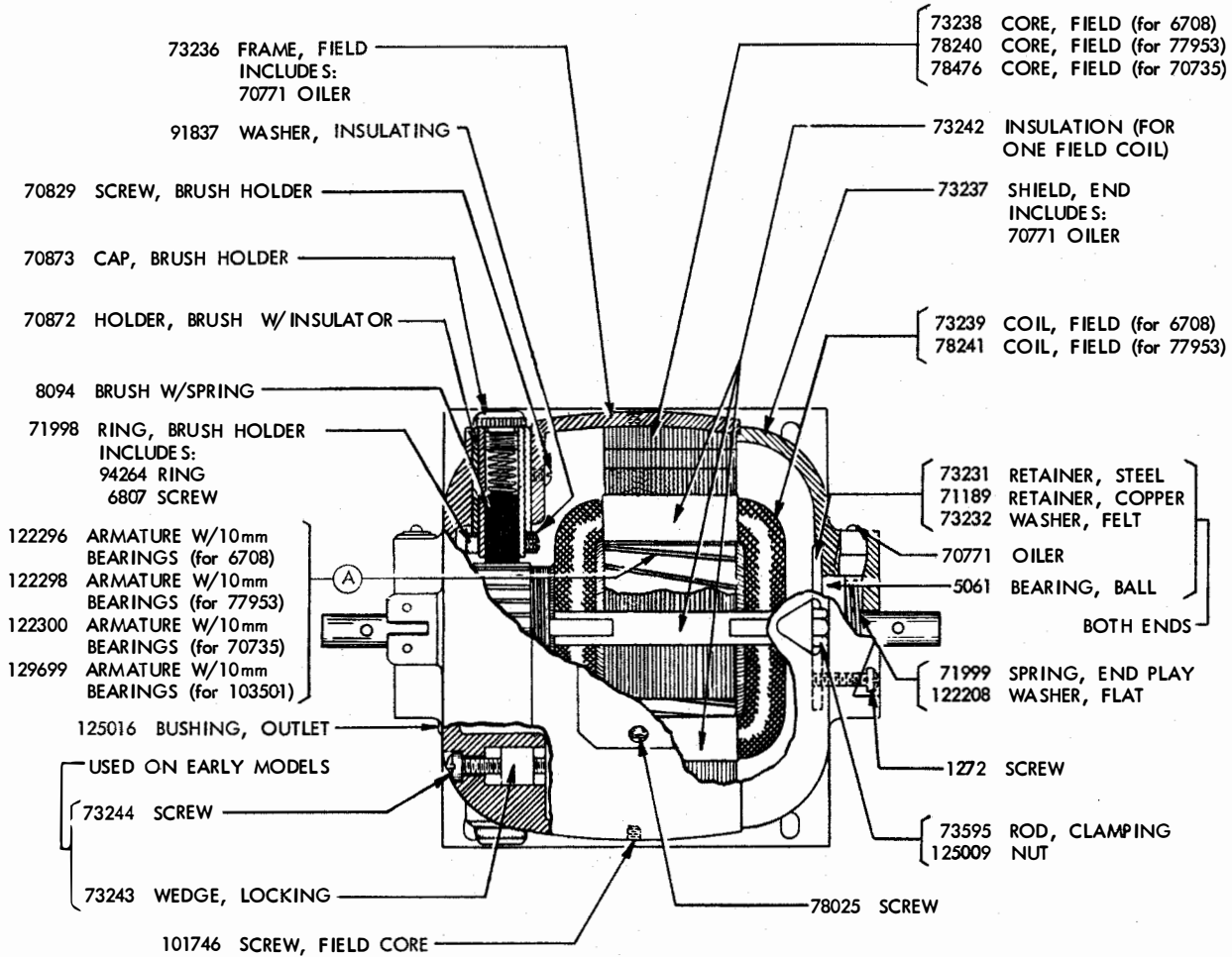

- 6708 SERIES MOTOR: 1/25 H.P., 110 V., 50/60 CYCLE, A.C. (G.E. Models 28478 or 5BA65AA77)
- 77953 SERIES MOTOR: 1/25 H.P., 110 V., 60 CYCLE, A.C. (G.E. Models 32989 or 5BA65AA29)
- 70735 SERIES MOTOR: 1/25 H.P., 220 V., 60 CYCLE, A.C. (G.E. Models 31810 or 5BA65AA116)
- 103501 SERIES MOTOR: 1/25 H.P., 110 V., 50 CYCLE, A.C. (G.E. Model 5BA65AA142)

(A) For explanation, see page 4-2.

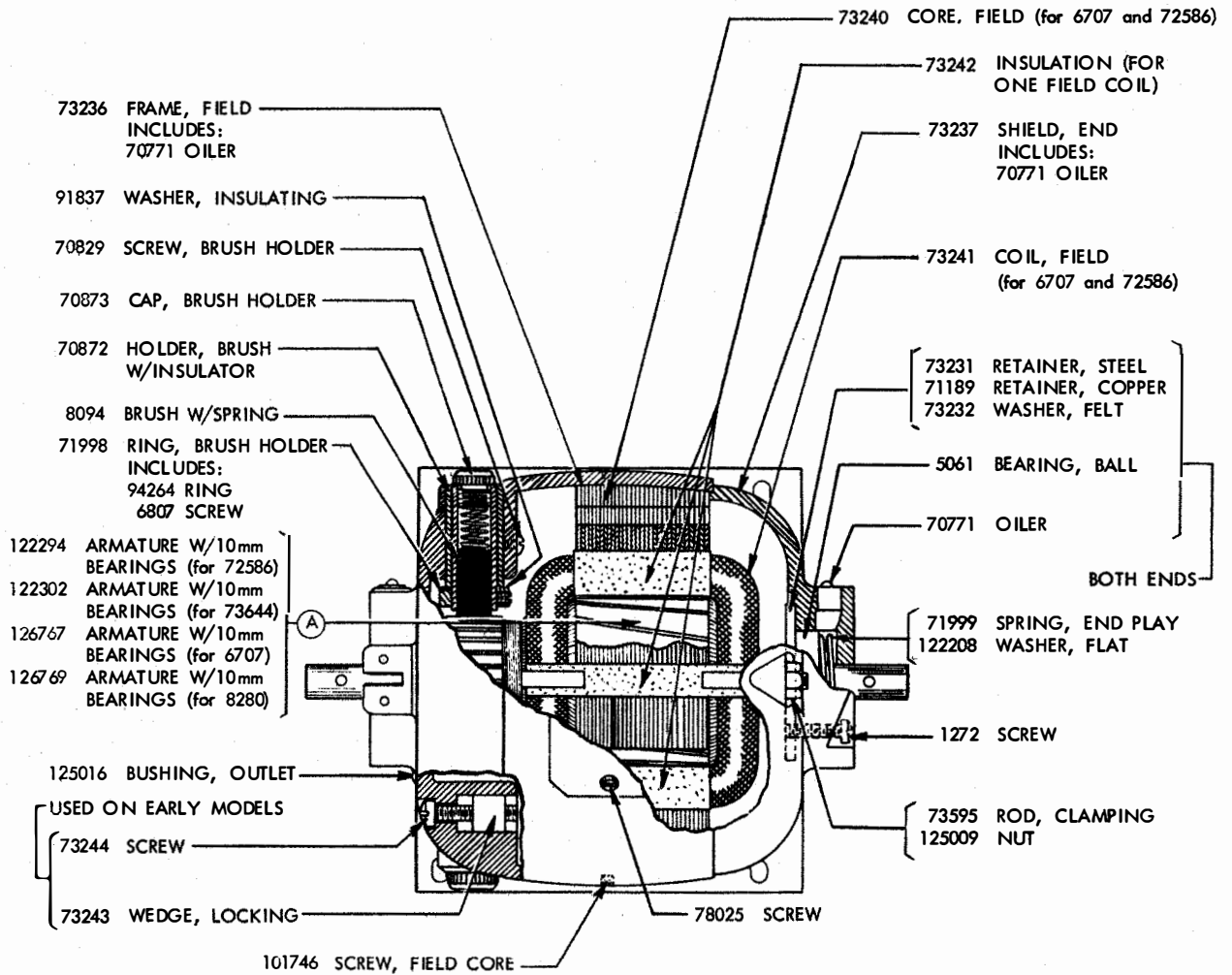

6707 SHUNT MOTOR: 1/20 H.P., 110 V., D.C. (G.E. Model 28479 or 5BY30A6)

8280 SHUNT MOTOR: 1/20 H.P., 220 V., D.C. (G.E. Model 31382 or 5BY30A7)

72586 SHUNT MOTOR: 1/17 H.P., 110 V., D.C. (G.E. Model 31531 or 5BY30A3)

73644 SHUNT MOTOR: 1/17 H.P., 220 V., D.C. (G.E. Model 33373 or 5BY30A10)

71610 SHUNT MOTOR: 1/17 H.P., 12 V., D.C. (G.E. Model 31661 or 5BY30A9)

(A) For explanation, see page 4-2.

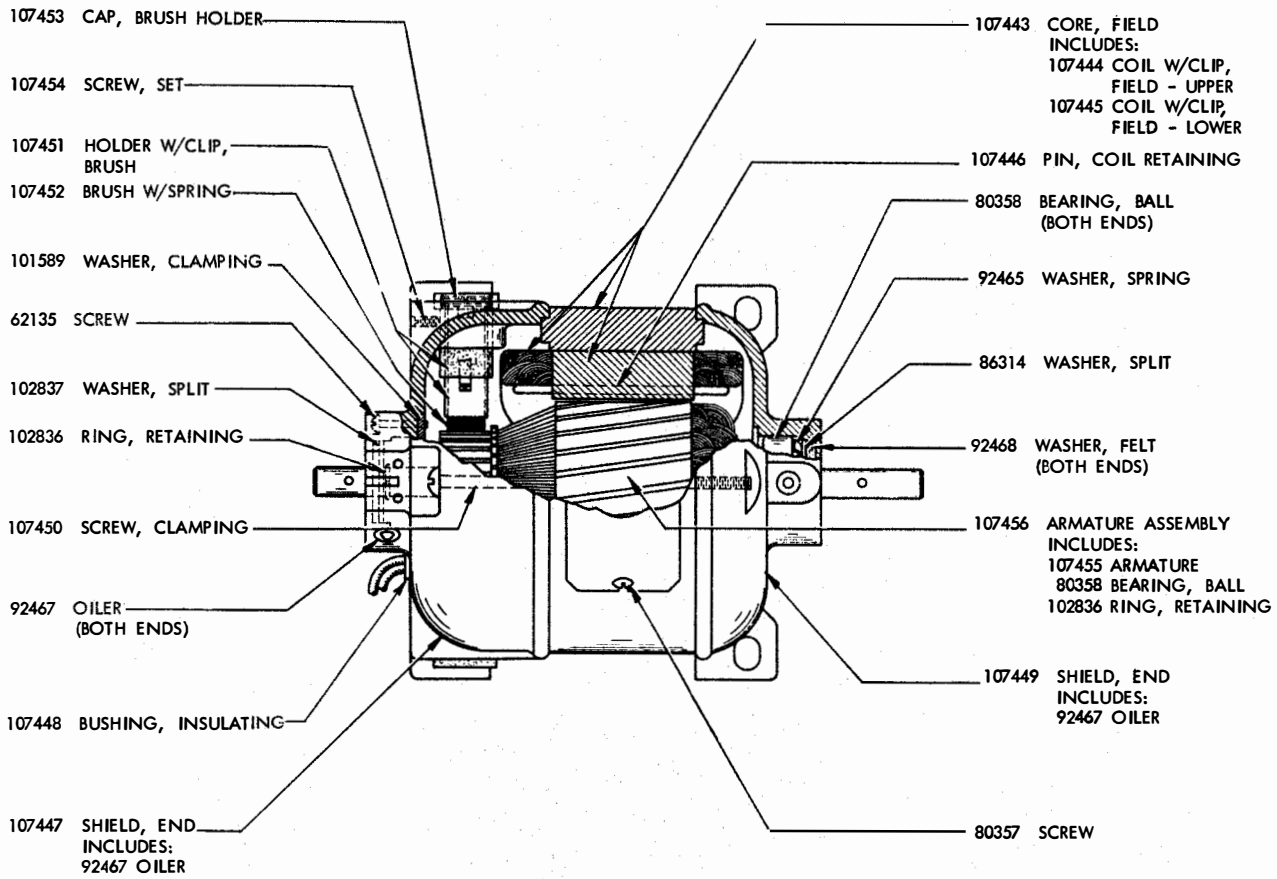

104038 SERIES MOTOR: 1/25 H.P., 115 V., 50/60 CYCLE A.C. (H.C. Model S-9050)

1147B

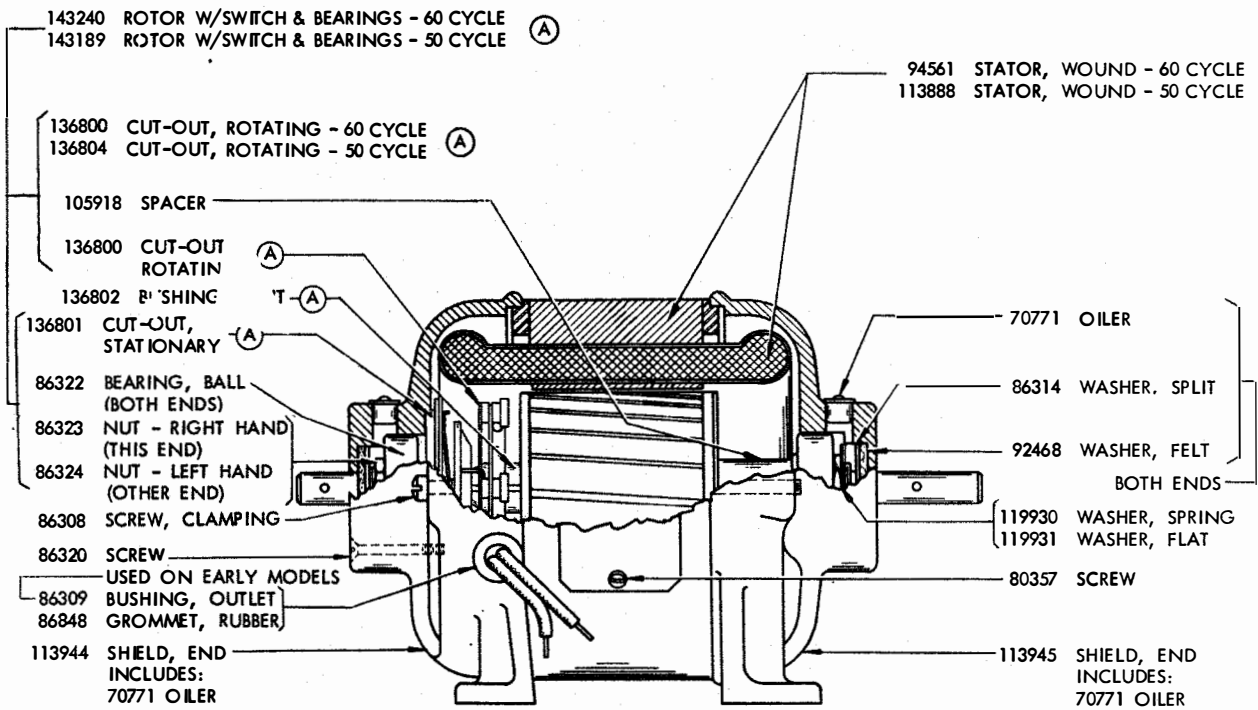

104061 SYNCHRONOUS MOTOR: 1/40 H.P., 115V., 50 CYCLE A.C. (H.C. MODEL S-9049)
 83799 SYNCHRONOUS MOTOR: 1/40 H.P., 115 V., 60 CYCLE A.C. (H.C. MODEL S-9005)

(WITH NEW STYLE CUT-OUT SWITCH-SEE BELOW FOR OLD STYLE)

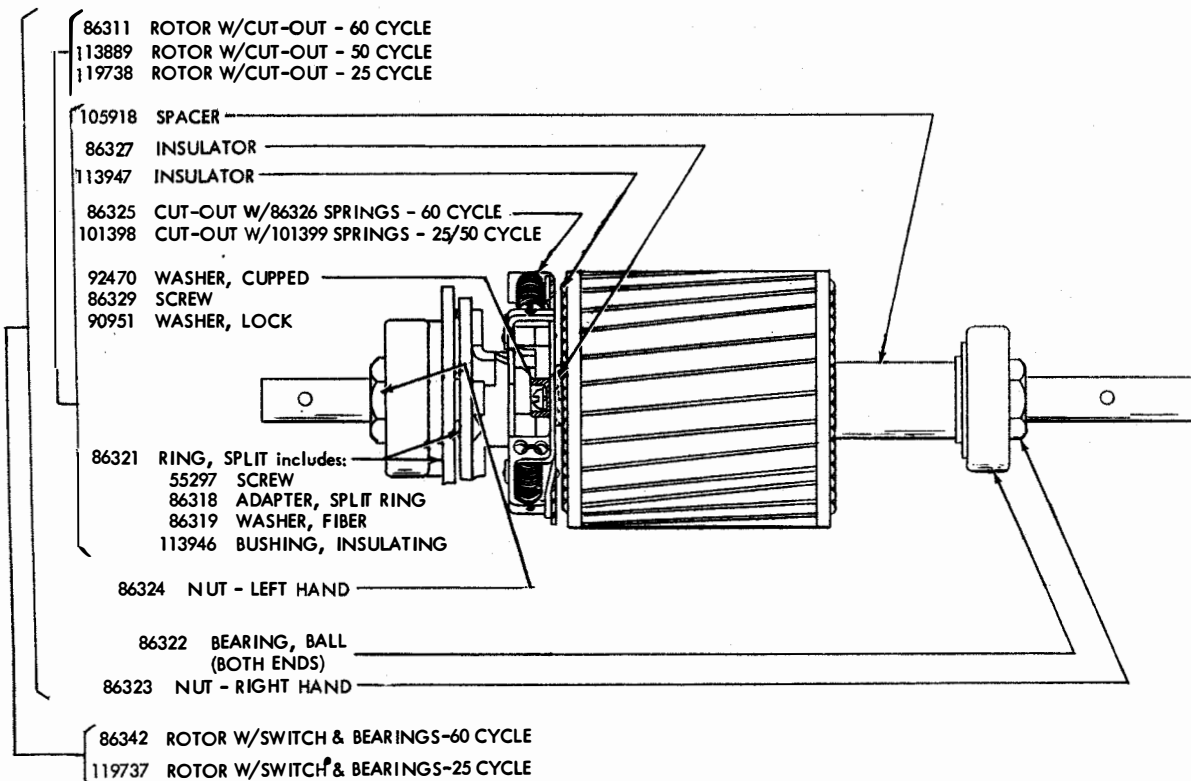

OLD STYLE CUT-OUT SWITCHES FOR HOLTZER-CABOT SYNCHRONOUS MOTORS

(A) For explanation, see page 4-2.



SECTION 4
NOTES AND NUMERICAL INDEX

NOTES OF EXPLANATION

Page 1-4

- (A) Parts marked (A) represent the new style cut-out switches for the Holtzer-Cabot synchronous motors. New and old cut-out switch assemblies are interchangeable, but their individual components are not. Old style switch components are still available for maintenance (See page 3-7).

Pages 3-4, 3-5

- (A) When a new style armature with 80358 ball bearings (10 mm) is installed in an old style motor, the following parts, used with the 5061 ball bearings, are to be omitted:

- (2) 73231 Retainer, Steel
- (2) 71189 Retainer, Copper
- (2) 73232 Washer, Felt
- (8) 1272 Screw

Make certain that the outer race of the old bearing is removed from each end shield before the new armature with 10 mm bearings is inserted. Place the large diameter of the 71999 end play spring and the 122208 flat washer adjacent to the bearing.

Instructions for modifying the present armature for two 80358 bearings (10 mm) may be obtained by requesting Specification 5651S. (Bearings not furnished with Specification.)

Page 3-7

- (A) When it is desirable to replace an old style cut-out switch with springs on a Holtzer-Cabot synchronous motor, a 136035 (60 cycle) or 136036 (25 or 50 cycle) Modification Kit to Provide an Improved Starting Winding Cut-Out Switch may be ordered instead. The modification kits (also illustrated on page 2-10) consists of the following parts:

		136035	136036
(1)	136800 Cut-Out, Rotating - 60 cycle	x	
(1)	136801 Switch, Stationary	x	x
(1)	136802 Bushing, Split	x	x
(1)	136804 Cut-Out, Rotating - 25/50 cycle		x

The old style cut-out mechanism consisted of a stationary split ring and a set of rotating brushes controlled by centrifugal force. In the new style cut-out mechanism the centrifugal action controls a set of stationary contacts. New and old style cut-out switch mechanisms are interchangeable but individual components are not.

A 136803 cut-out mounting collar (tool), illustrated below, is required for assembling the new parts in a motor and should be ordered separately. Instructions for installing the new style mechanism may be obtained by requesting Specification 5770S. (Cut-out not furnished with Specification.)

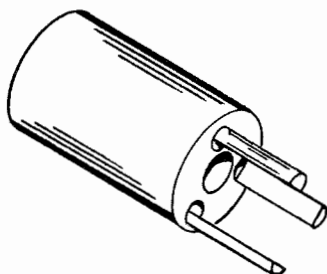

NUMERICAL INDEX

Part Number	Description and Page Number	Part Number	Description and Page Number
1064	Screw (6-32 x 1/4 Rd) 2-3, 2-4, 2-5, 2-8	62135	Screw (6-32 x 5/8 Rd) 3-6
1118	Screw (6-40 Shoulder) 2-5	70735	Motor, A.C. Series 3-4
1272	Screw (6-40 x 11/16 Fil) 3-4, 3-5, 4-2	70771	Oiler 1-3, 1-4, 1-5, 3-4, 3-5, 3-7
1297	Screw (6-40 x 7/16 Fil) 2-6, 2-7	70829	Screw (8-36 x 5/16 Rd) 1-4, 1-5, 3-4, 3-5
1303	Screw (6-40 x 13/32 Fil) 2-4	70872	Holder, Brush 1-4, 1-5, 3-4, 3-5
2191	Washer, Lock 2-2, 2-3, 2-4, 2-5, 2-6, 2-7, 2-8	70873	Cap 1-4, 1-5, 3-4, 3-5
2407	Washer, Lack 2-10	70892	Nut (1/8-27 Hex) 2-10
2669	Washer, Lock 2-3, 2-4	70893	Fitting, Pipe 2-10
3043	Resistor 2-7	71155	Screw (6-32 x 1-1/4 Flat) 2-7
3094	Insulator 2-7	71189	Retainer 5-4, 3-5, 4-2
3438	Washer, Flat 2-3, 2-4	71610	Motor, D.C. Shunt 3-2, 3-5
3598	Nut (6-40 Hex) 2-4, 2-6, 2-7	71998	Ring 1-4, 1-5, 3-4, 3-5
3599	Nut (4-40 Hex) 2-5	71999	Spring 1-4, 1-5, 3-4, 3-5, 4-2
3640	Washer, Lock 2-3, 2-4, 2-5 2-8, 2-10	72586	Motor, D.C. Shunt 3-2, 3-5
5061	Bearing, Ball 3-4, 3-5, 4-2	72665	Target 2-9
6033	Washer, Lock 1-3	73231	Retainer 3-4, 3-5, 4-2
6301	Cover 2-8	73232	Washer, Felt 3-4, 3-5, 4-2
6305	Brush 2-6, 2-8	73236	Frame 1-4, 1-5, 3-4
6306	Holder, Brush 2-8	73237	Shield, End 1-4, 1-5, 3-4, 3-5
6314	Spring 2-3, 2-4, 2-5, 2-8	73238	Coil 1-4, 3-4
6318	Clamp 2-3, 2-4, 2-5, 2-8	73239	Coil 1-4, 3-4
6319	Block 2-3, 2-4, 2-5, 2-8	73240	Core 1-4, 1-5, 3-5
6320	Screw (6-32 x 9/32 Hex) 2-3, 2-4, 2-5, 2-8	73241	Coil 1-5, 3-5
6323	Spring 2-3, 2-4, 2-5, 2-8	73242	Insulation 1-4, 1-5, 3-4, 3-5
6324	Wheel 2-3, 2-4, 2-8	73243	Wedge 3-4, 3-5
6330	Bearing 2-3, 2-4, 2-8	73244	Screw (10-32 x 7/8 Fil) 3-4, 3-5
6340	Ring 2-8	73376	Target 2-9
6341	Bushing 2-5, 2-8	73377	Target 2-9
6342	Wire 2-8	73595	Rod 1-4, 1-5, 3-4, 3-5
6344	Screw (6-32 x 11/32 Hex) 2-3, 2-4, 2-5, 2-8	73644	Motor, D.C. Shunt 3-2, 3-5
6345	Nut (6-32 Hex) 2-3, 2-4, 2-5, 2-8	74557	Lamp 2-10
6346	Screw (6-32 x 3/4 Fil) 2-5, 2-8	74558	Socket 2-10
6347	Screw (6-32 x 3/8 Rd) 2-3, 2-4, 2-5, 2-8	74728	Terminal 2-2
6348	Screw (4-36 x 3/4 Rd) 2-3, 2-4, 2-8	74931	Motor, A.C. Synchronous 3-2
6349	Screw (6-32 x 1/2 Rd) 2-5	74986	Screw (6-40 x 13/32 Hex) 2-7
6707	Motor, D.C. Shunt 3-2, 3-5	77953	Motor, A.C. Series 3-2, 3-4
6708	Motor, A.C. Series 3-2, 3-4	78011	Capacitor 2-7
6770	Disk 2-8	78025	Screw (4-48 x 3/16 Rd) 1-2, 1-4, 1-5, 3-4, 3-5
6807	Screw (6-40 Set) 1-4, 1-5, 3-4, 3-5	78217	Motor, A.C. Synchronous 3-2
6885	Bracket 2-8	78240	Core 3-4
6966	Eccentric 2-5	78241	Coil 1-4, 3-4
6979	Hub 2-3, 2-4, 2-5 2-8	78398	Bushing 2-2
6991	Gear 2-7	78399	Spring 2-2
7002	Washer, Flat 2-2, 2-3, 2-5, 2-6, 2-7, 2-8	78400	Spring 2-2
7082	Pinion 2-7	78403	Brush 2-2
7105	Target 2-9	78437	Insulator 2-3, 2-4
7106	Target 2-9	78438	Bushing 2-3, 2-4
7107	Target 2-9	78439	Shell, Governor 2-3, 2-4
7485	Governor 2-8	78443	Disk 2-3, 2-4
7704	Target 2-9	78451	Cover 2-3, 2-4
7705	Target 2-9	78476	Core 1-4, 3-4
8094	Brush 1-4, 1-5, 3-4, 3-5	78496	Spring 2-3, 2-4
8165	Washer, Friction 2-3, 2-4, 2-8	78497	Spring 2-3, 2-4
8280	Motor, D.C. Shunt 3-2, 3-5	80299	Spring 1-2
8425	Target 2-9	80307	Outlet 3-3
41732	Plate 2-2	80308	Bushing 3-3
41733	Insulator 2-2	80309	Washer, Felt 1-2
50083	Screw (6-32 x 1-1/8 Fil) 2-5	80310	Washer, Felt 1-2
55297	Screw (6-32 x 5/16 Flat) 3-7	80311	Washer, Cupped 1-2

NUMERICAL INDEX (Continued)

Part Number	Description and Page Number	Part Number	Description and Page Number
80313	Washer, Split 1-2	86321	Ring, Split 3-7
80334	Terminal 2-2	86322	Bearing, Ball 1-3, 3-7
80335	Plate 2-2	86323	Nut (7/16-24 Hex) 1-3, 3-7
80336	Insulator 2-2	86324	Nut (7/16-24 Hex) 1-3, 3-7
80337	Bracket 2-2	86325	Cut-Out 3-7
80338	Bracket 2-2	86327	Insulator 3-7
80340	Plate 2-2	86329	Screw (4-40 x 7/16 Rd) 3-7
80341	Bracket Assembly 2-2	86342	Rotor 3-7
80342	Screw (6-40 x 23/64 Hex) 2-2, 2-6, 2-7	86615	Rotor 1-2
80351	Screw (8-36 x 5/16 Rd) 3-3	86616	Spring 1-2
80352	Governor 2-3	86617	Rotor 1-2
80357	Screw (4-48 x 1/4 Rd) 3-6, 3-7	86713	Screw (4-48 x 5/16 Rd) 1-2
80358	Bearing, Ball 1-2, 1-4, 1-5, 3-6, 4-2	86812	Bracket 2-2
80553	Motor, A.C. Synchronous 3-2	86848	Grommet 1-3, 3-7
80559	Screw (8-36 x 1.516 Fil) 3-3	86852	Plate 2-2
80754	Oiler 1-2	86853	Bracket Assembly 2-2
81638	Spacer 2-4	86868	Bushing 2-3, 2-4, 2-5, 2-8
82000	Guard 2-7	86869	Post, Spring 2-3, 2-4, 2-5, 2-8
82005	Holder, Brush 2-6	88879	Support 1-2
82283	Motor, A.C. Synchronous 1-2, 2-10, 3-2, 3-3	89405	Bushing 1-2
82285	Resistor 2-7	89406	Washer, Spring 1-2
82288	Screw (4-40 x 1/4 Rd) 1-3	89407	Pin 1-2
82305	Arm 2-5	89969	Washer, Insulating 2-6, 2-7
82306	Arm 2-5	90263	Stator 1-2, 3-3
82307	Bracket 2-5	90511	Screw (6-40 x .820 Hex) 2-6
82308	Ring 2-8	90951	Washer, Lock 3-7
82310	Ring 2-8	91041	Stator 1-2
82311	Wheel 2-5	91275	Cable 2-6
82312	Block 2-5	91276	Bracket 2-6, 2-10
82316	Bracket 2-6	91506	Bracket 2-6
82339	Spring 2-5	91522	Disk 2-5
82341	Disk 2-5	91683	Nut (15/32-32 Hex) 2-6, 2-7, 2-10
82344	Switch 2-6, 2-10	91684	Nut (15/32-32 Ring) 2-6, 2-7, 2-10
82350	Bracket 2-7	91837	Washer, Insulating 1-4, 1-5, 3-4, 3-5
82361	Holder, Brush 2-6	92465	Washer, Spring 3-6
82396	Plate 2-7	92467	Oiler 3-6
82397	Plate 2-7	92468	Washer, Felt 1-3, 3-6, 3-7
82398	Resistor Bracket Assembly 2-7	92470	Washer, Cupped 3-7
82474	Terminal 2-7	92575	Motor, A.C. Synchronous 1-3
82505	Screw (6-32 x 11/32) 2-5	92721	Cable 2-6
82622	Motor, A.C. Synchronous 3-2	93035	Bushing 2-7
82714	Motor, A.C. Synchronous 1-2	93075	Nut (15/32-32 Shoulder Hex) 2-10
82839	Rotor 1-2	93108	Washer, Lock 1-3
82840	Rotor 1-2	93903	Target 2-9
82841	Switch 1-2	94009	Switch 2-10
82843	Spring 1-2	94264	Ring 1-4, 1-5, 3-4, 3-5
82845	Washer, Flat 1-2	94558	Base 1-3
82848	Holder W/Brush 1-2	94559	Shield, End 1-3
82850	Shield, End 1-2, 3-3	94560	Shield, End 1-3
83799	Motor, A.C. Synchronous 3-2, 3-7	94561	Stator 1-3, 3-7
84105	Pinion 2-6	94562	Spring 1-3
84106	Gear 2-6	94565	Screw (8-32 x 13/32 Fil) 1-3
86308	Screw (10-32 x 4-3/8 Fil) 1-3, 3-7	94566	Screw (8-32 Shoulder) 1-3
86309	Bushing 1-3, 3-7	94707	Insulator 1-2
86311	Rotor 3-7	95222	Resistor 2-6
86314	Washer, Split 1-3, 3-6, 3-7	95329	Fan 2-4
86318	Adapter 3-7	95330	Plate 2-4
86319	Washer, Fiber 3-7	95331	Plate 2-4
86320	Screw (8-32 x 1-1/16 Flat) 1-3, 3-7	95332	Governor Assembly 2-4

NUMERICAL INDEX (Continued)

Part Number	Description and Page Number	Part Number	Description and Page Number
98846	Cable 2-7	113947	Insulator 3-7
98899	Switch 2-7	114321	Motor, A.C. Synchronous 1-3
101398	Cut-Out 3-7	114754	Fork, Tuning 2-9
101589	Washer, Clamping 3-6	114755	Fork, Tuning 2-9
101746	Screw (12-28 Set) 1-4,3-4,3-5	114756	Fork, Tuning 2-9
102774	Screw (8-36 x 4-3/8 Rd) 1-2,3-3	114757	Fork, Tuning 2-9
102788	Bracket 2-7	114758	Fork, Tuning 2-9
102836	Ring, Retaining 3-6	114759	Fork, Tuning 2-9
102837	Washer, Split 3-6	116402	Motor, A.C./D.C. Series 3-2
103311	Governor 2-5	119737	Rotor 3-7
103312	Modification Kit 2-7	119738	Rotor 3-8
103313	Modification Kit 2-7	119739	Shield, End 1-3
103315	Cable 2-7	119740	Grommet 1-3
103431	Grommet 1-2,3-3	119741	Stator 1-3
103435	Governor 2-7	119895	Resistor 2-7
103501	Motor, A.C. Series 3-2,3-4	119930	Washer, Spring 1-3,3-7
103543	Modification Kit 2-6	119931	Washer, Flat 1-3,3-7
103544	Modification Kit 2-6	121272	Motor, A.C./D.C. Series 1-6,3-2
103628	Fork, Tuning 2-9	121335	Modification Kit 3-2
103699	Screw (6-32 x 5/8 Flat) 2-4	122109	Insulator 1-6
104038	Motor, A.C. Series 3-2,3-6	122110	Brush 1-6
104061	Motor, A.C. Synchronous 3-2,3-7	122111	Cap 1-6
104262	Case 2-9	122112	Holder, Brush 1-6
104748	Fork, Tuning 2-9	122113	Shield, End 1-6
104809	Oiler 1-6	122114	Shield, End 1-6
104980	Fork, Tuning 2-9	122195	Armature 1-6
104981	Fork, Tuning 2-9	122196	Bearing, Ball 1-6
104982	Fork, Tuning 2-9	122197	Washer, Pull 1-6
104983	Fork, Tuning 2-9	122208	Washer, Flat 1-2,1-4,1-5,3-4,3-5,4-2
104984	Fork, Tuning 2-9	122230	Washer, Spring 1-6
104985	Fork, Tuning 2-9	122234	Screw (6-40 x 3-9/16 Rd) 1-6
104986	Fork, Tuning 2-9	122235	Washer, Felt 1-6
104987	Fork, Tuning 2-9	122236	Retainer 1-6
104988	Fork, Tuning 2-9	122237	Washer, Fiber 1-6
105912	Washer, Lock 2-10	122238	Shim 1-6
105918	Spacer 1-3,3-7	122239	Frame 1-6
106875	Motor, A.C. Series 3-2	122240	Insulator 1-6
107151	Motor, A.C. Series 3-2	122241	Clamp 1-6
107443	Core 3-6	122293	Motor, D.C. Shunt 1-5,3-2
107444	Coil 3-6	122294	Armature 1-5,3-5
107445	Coil 3-6	122295	Motor, A.C. Series 1-4,3-2
107446	Pin 3-6	122296	Armature 1-4,3-4
107447	Shield, End 3-6	122297	Motor, A.C. Series 1-4,3-2
107448	Bushing 3-6	122298	Armature 1-4,3-4
107449	Shield, End 3-6	122299	Motor, A.C. Series 1-4,3-2
107450	Screw (10-32 x 3-5/8 Rd) 3-6	122300	Armature 1-4,3-4
107451	Holder, Brush 3-6	122301	Motor, D.C. Shunt 1-5,3-2
107452	Brush 3-6	122302	Armature 1-5,3-5
107453	Cap 3-6	125009	Nut (10-32 Hex) 1-4,1-5,3-4,3-5
107454	Screw (10-32 Set) 3-6	125013	Strap 2-7
107455	Armature 3-6	125016	Bushing 1-4,1-5,3-4,3-5
107456	Armature 3-6	125199	Screw (6-32 x 9/16 Flat) 2-4
111447	Disk 2-5	125206	Screw (6-32 x 5/8 Fil) 2-8
112626	Nut (10-32 Hex) 2-3,2-4	126237	Nut (8-36 Hex) 1-2,3-3
113888	Stator 3-7	126766	Motor, D.C. Shunt 1-5,3-2
113889	Rotor 3-7	126767	Armature 1-5,3-5
113944	Shield, End 3-7	126768	Motor, D.C. Shunt 1-5,3-2
113945	Shield, End 3-7	126769	Armature 1-5,3-5
113946	Bushing 3-7	129668	Motor, A.C. Series 1-4,3-2

NUMERICAL INDEX (Continued)

Part Number	Description and Page Number
129669	Armature 1-4, 3-4
129752	Winding 1-6
136035	Modification Kit 2-10, 4-2
136036	Modification Kit 2-10, 4-2
136132	Modification Kit 2-10
136652	Bracket 2-6
136653	Cable 2-6
136800	Cut-Out 1-3, 2-10, 3-7, 4-2
136801	Switch 1-3, 2-10, 3-7, 4-2
136802	Bushing 2-10, 3-7, 4-2
136803	Tool 4-2
136804	Cut-Out 1-3, 2-10, 3-7, 4-2
138598	Holder, Brush 2-6
138809	Motor 1-2
138935	Stator 1-2
139381	Lamp Assembly 2-10
139630	Box, Switch 2-10
139631	Plate 2-10
139632	Switch 2-10
143189	Rotor 3-7
143240	Rotor 1-3, 3-7
143241	Rotor 1-3
150089	Screw (4-40 x 1/2 Fil) 2-10
151442	Screw (6-40 x 1/2 Hex) 2-2
151630	Screw (6-40 x 1/4 Hex) 2-2
151631	Screw (6-40 x 5/16 Hex) 2-2, 2-6, 2-7
151685	Screw (4-40 x 5/16 Fil) 2-2
153442	Screw (10-32 x 1/2 Hex) 2-8
153539	Screw (6-40 x 11/16 Hex) 2-6
153839	Screw (6-40 x 5/8 Hex) 2-3