

symbol of leadership

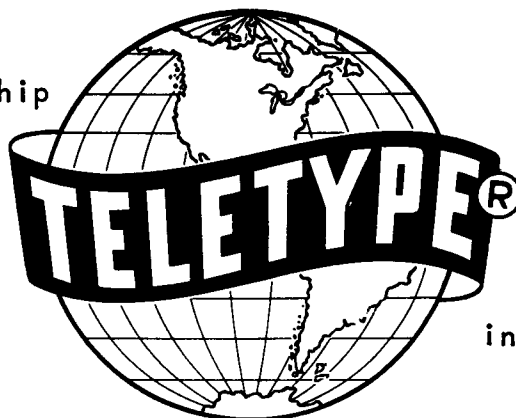

in printing telegraphy

BULLETIN 1124B

MAINTENANCE TOOLS

TELETYPE[®]
CORPORATION
SUBSIDIARY OF *Western Electric Company* INC.
SKOKIE, ILLINOIS, U.S.A.

LIST OF EFFECTIVE PAGES

OCTOBER, 1962

(Supersedes February, 1962 Issue)

Page Number	Change In Effect
1 through 13	Change 4

The above list indicates the effective pages as of the date of issue. Upon receipt of change pages, insert them numerically and discard any superseded pages.

Bell System Only

When ordering parts from this bulletin, prefix each number with the letters TP.

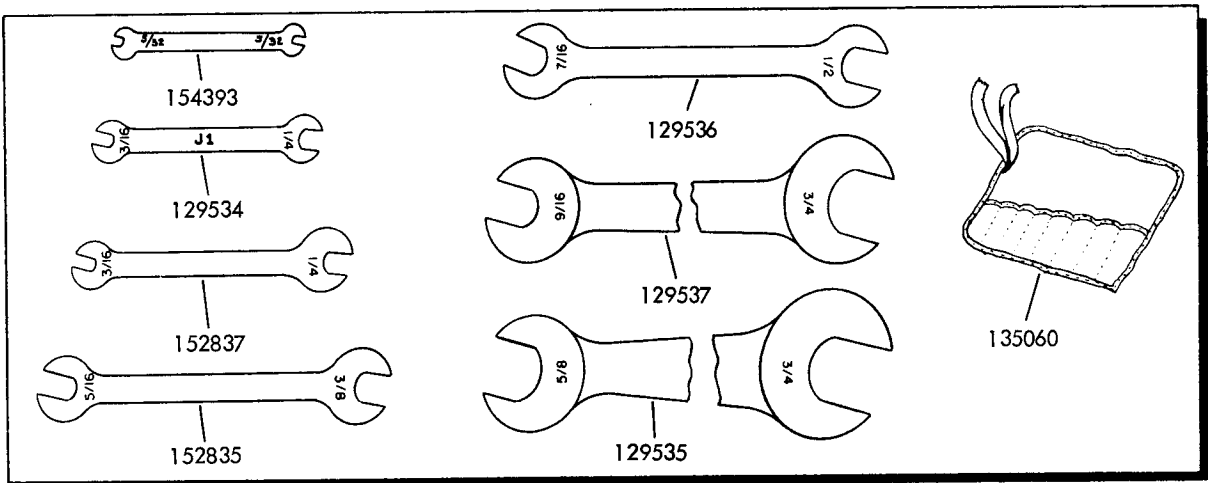
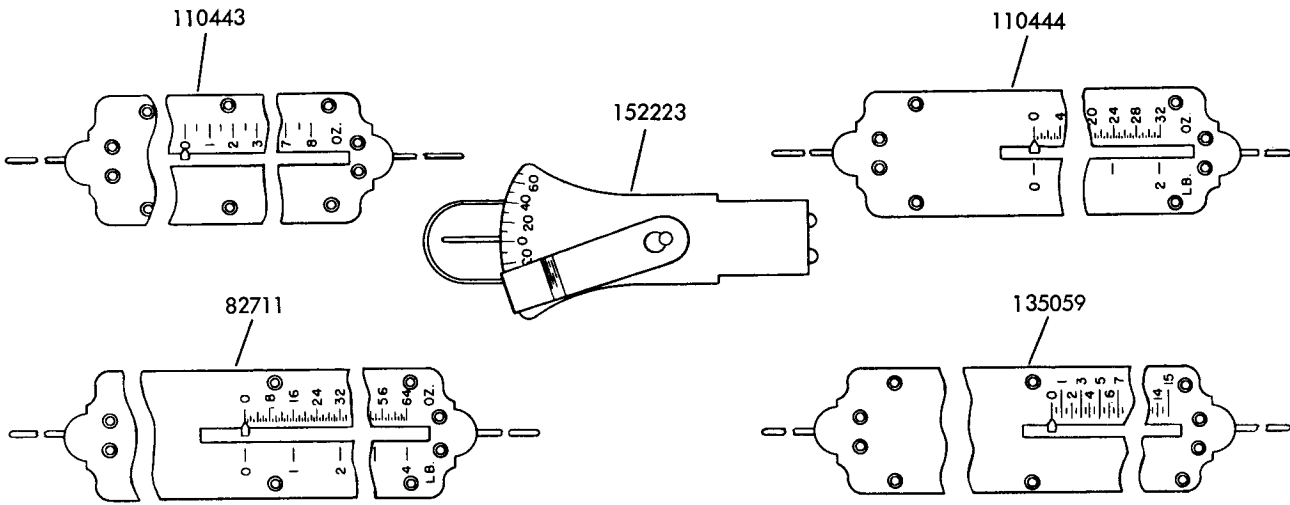

113756

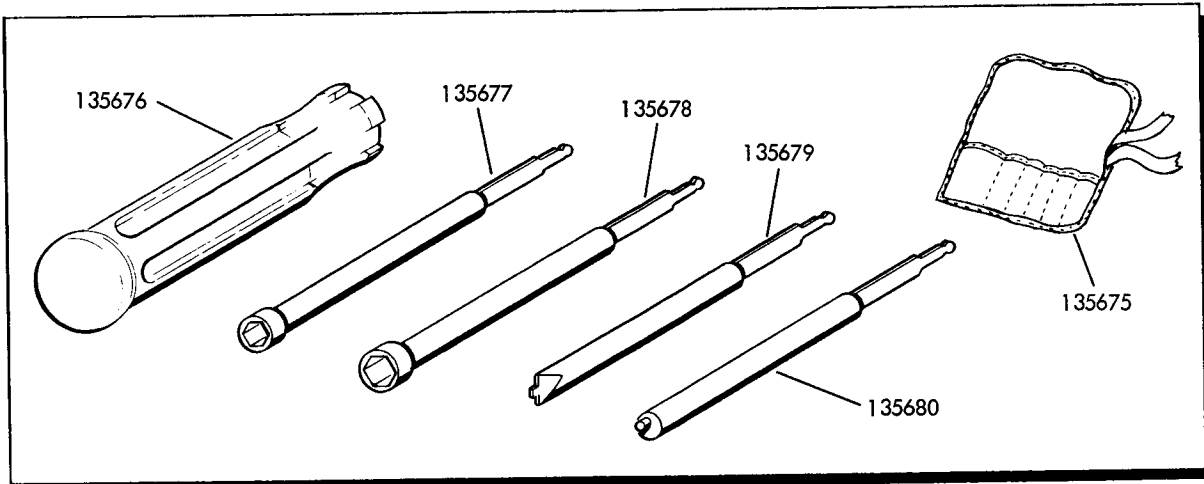

113777

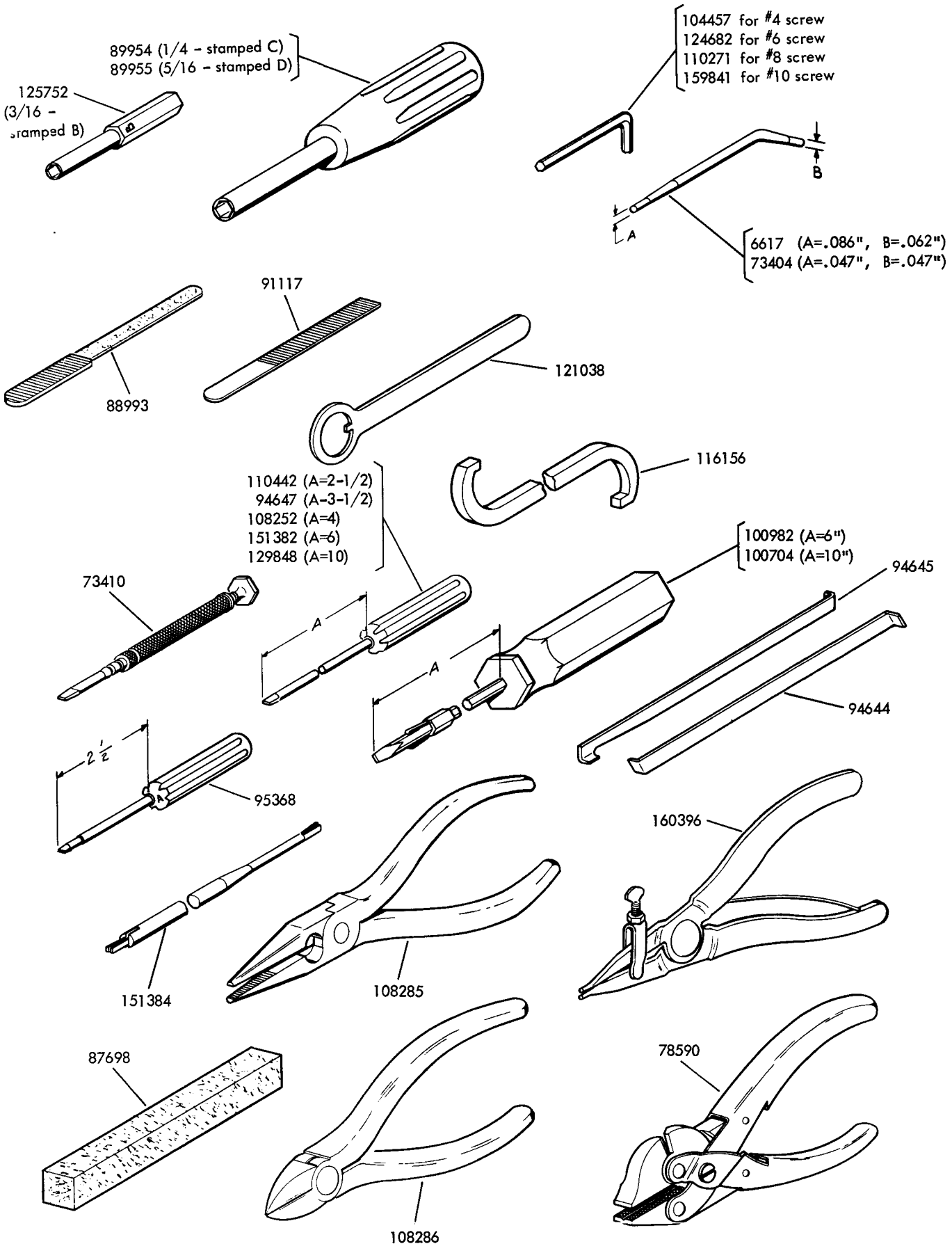

1124B

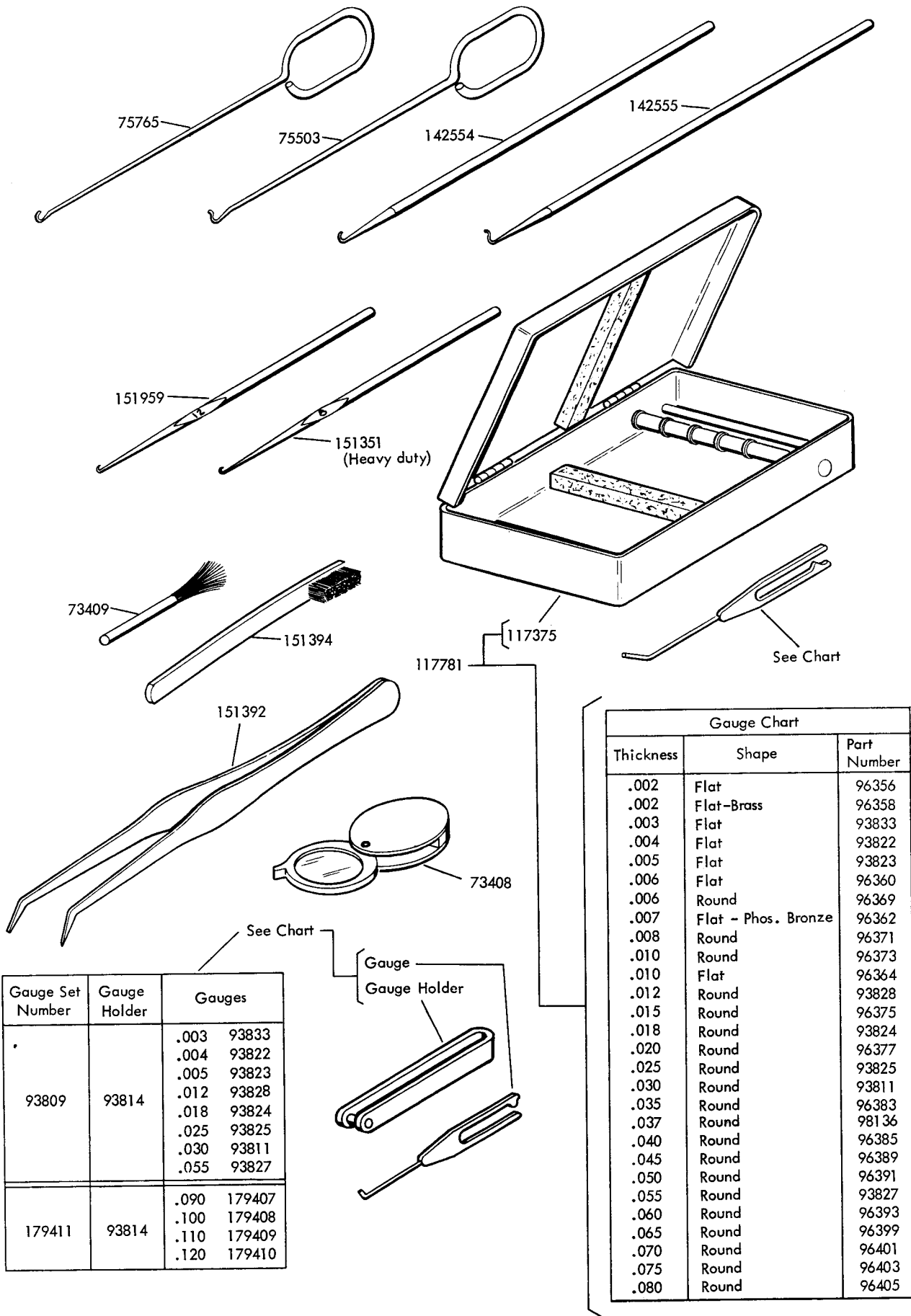

Gauge Set Number	Gauge Holder	Gauges	
93809	93814	.003	93833
		.004	93822
		.005	93823
		.012	93828
		.018	93824
		.025	93825
		.030	93811
179411	93814	.090	179407
		.100	179408
		.110	179409
		.120	179410

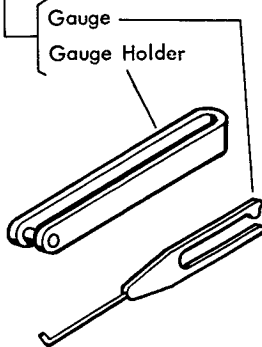

Gauge Chart		
Thickness	Shape	Part Number
.002	Flat	96356
.002	Flat-Brass	96358
.003	Flat	93833
.004	Flat	93822
.005	Flat	93823
.006	Flat	96360
.006	Round	96369
.007	Flat - Phos. Bronze	96362
.008	Round	96371
.010	Round	96373
.010	Flat	96364
.012	Round	93828
.015	Round	96375
.018	Round	93824
.020	Round	96377
.025	Round	93825
.030	Round	93811
.035	Round	96383
.037	Round	98136
.040	Round	96385
.045	Round	96389
.050	Round	96391
.055	Round	93827
.060	Round	96393
.065	Round	96399
.070	Round	96401
.075	Round	96403
.080	Round	96405

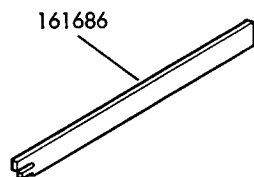
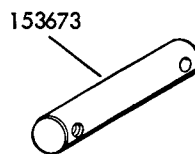
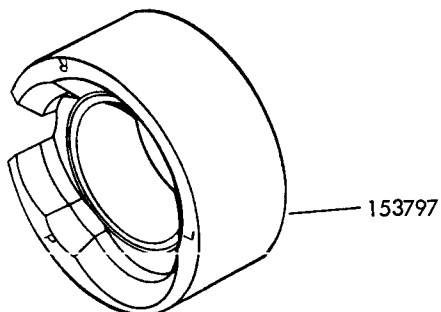
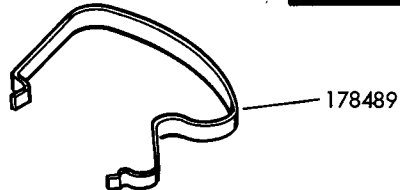
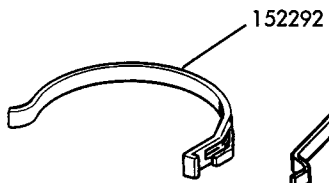
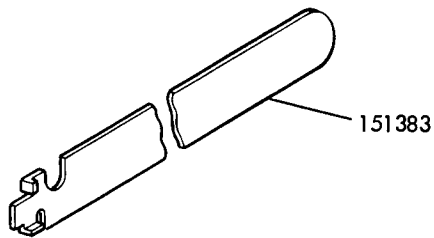
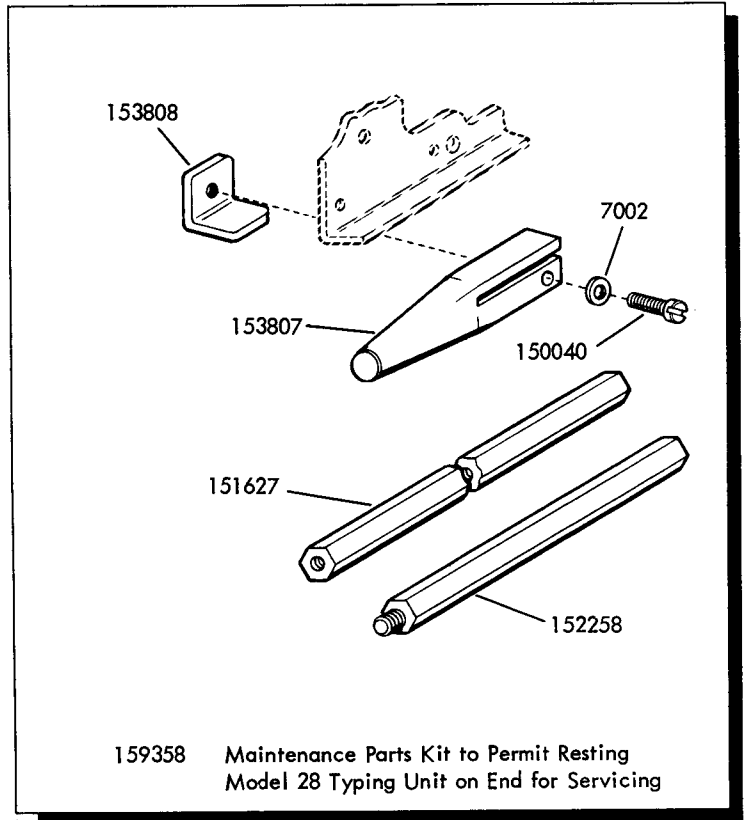
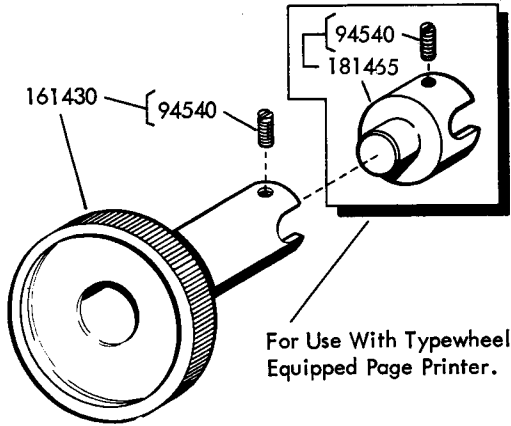
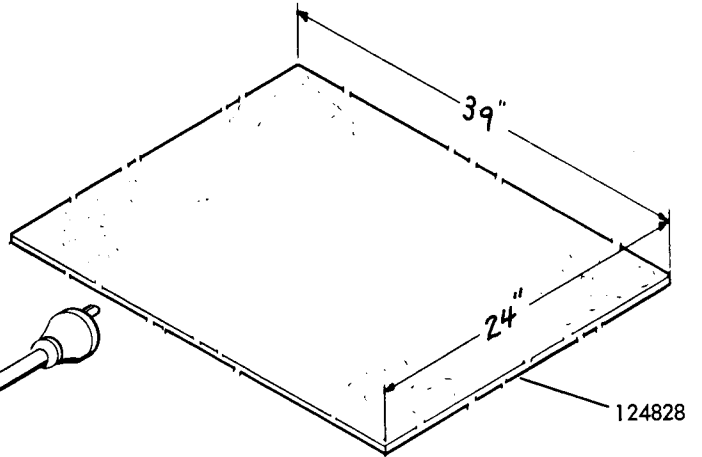
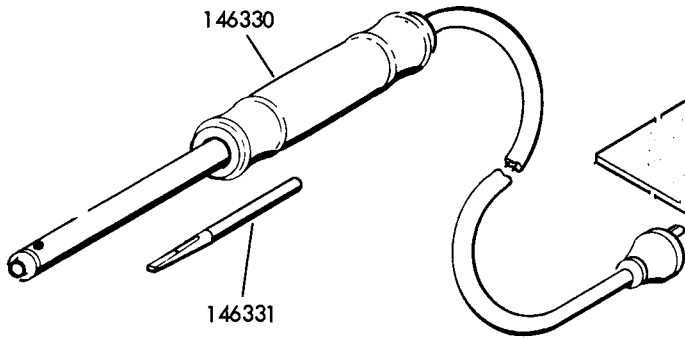

1124B

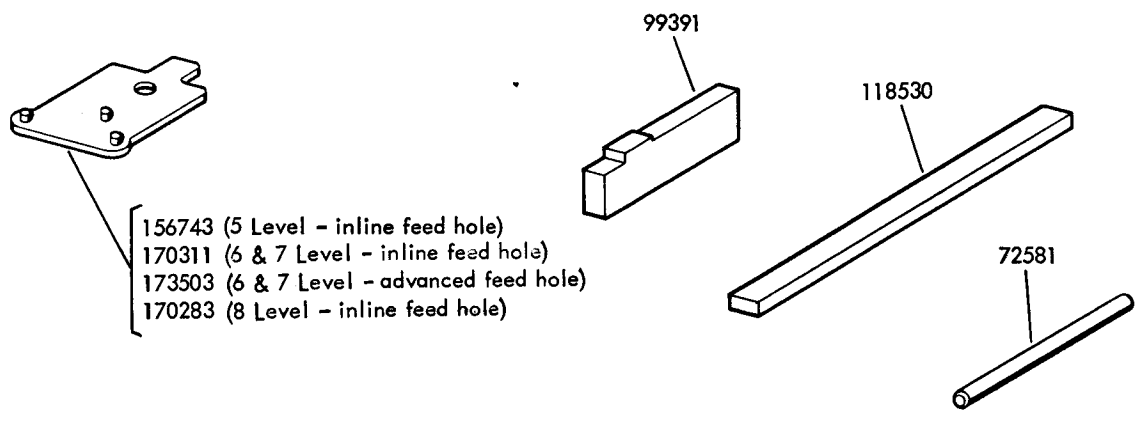
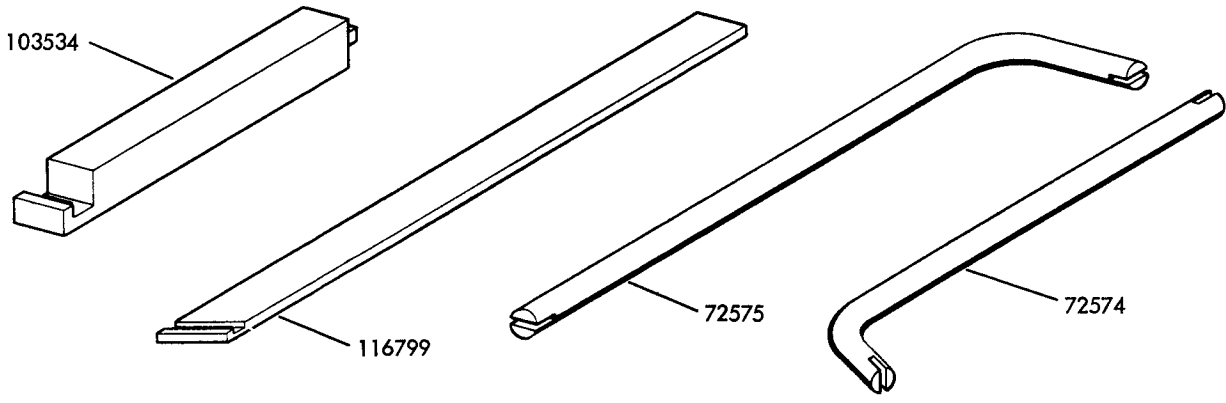
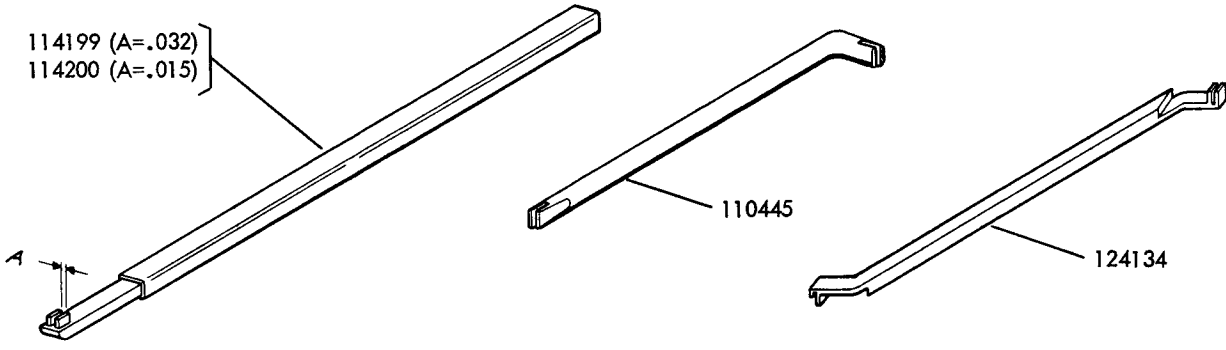
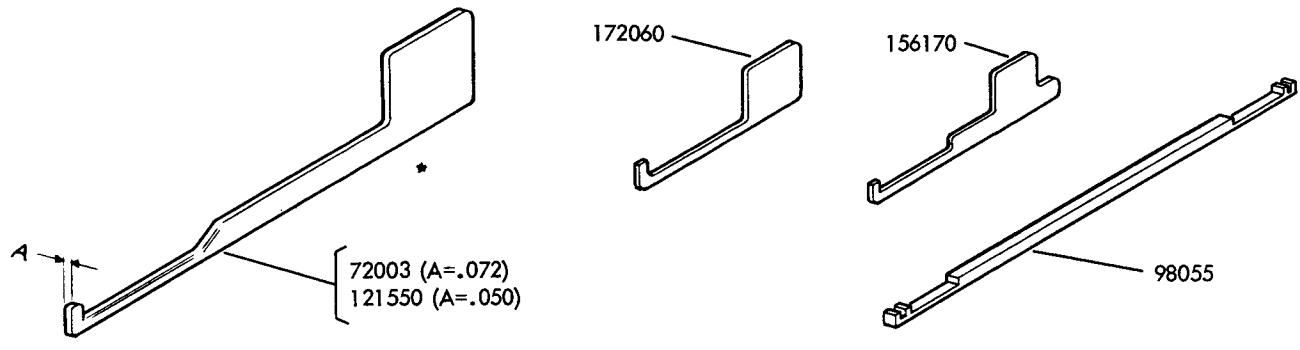

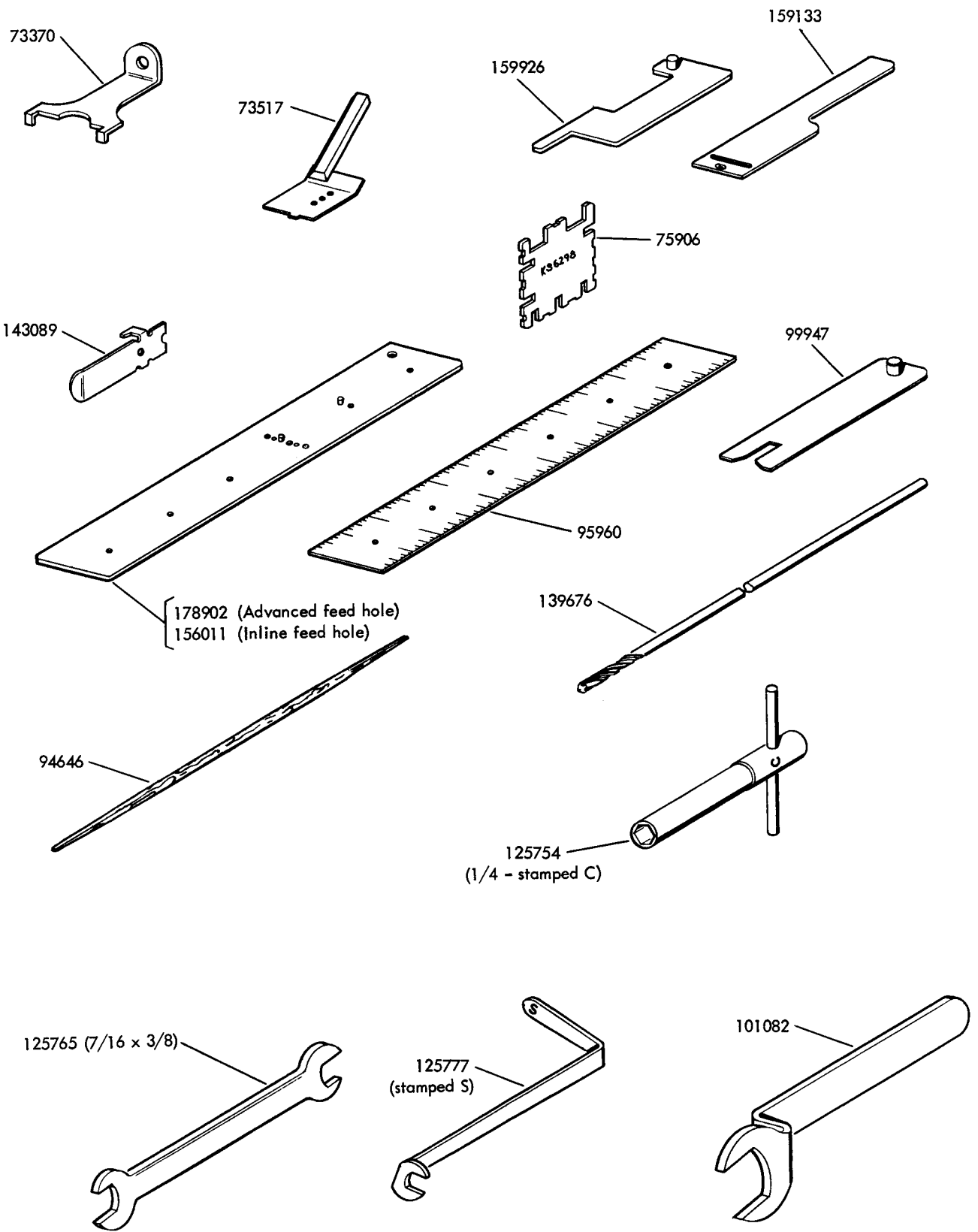

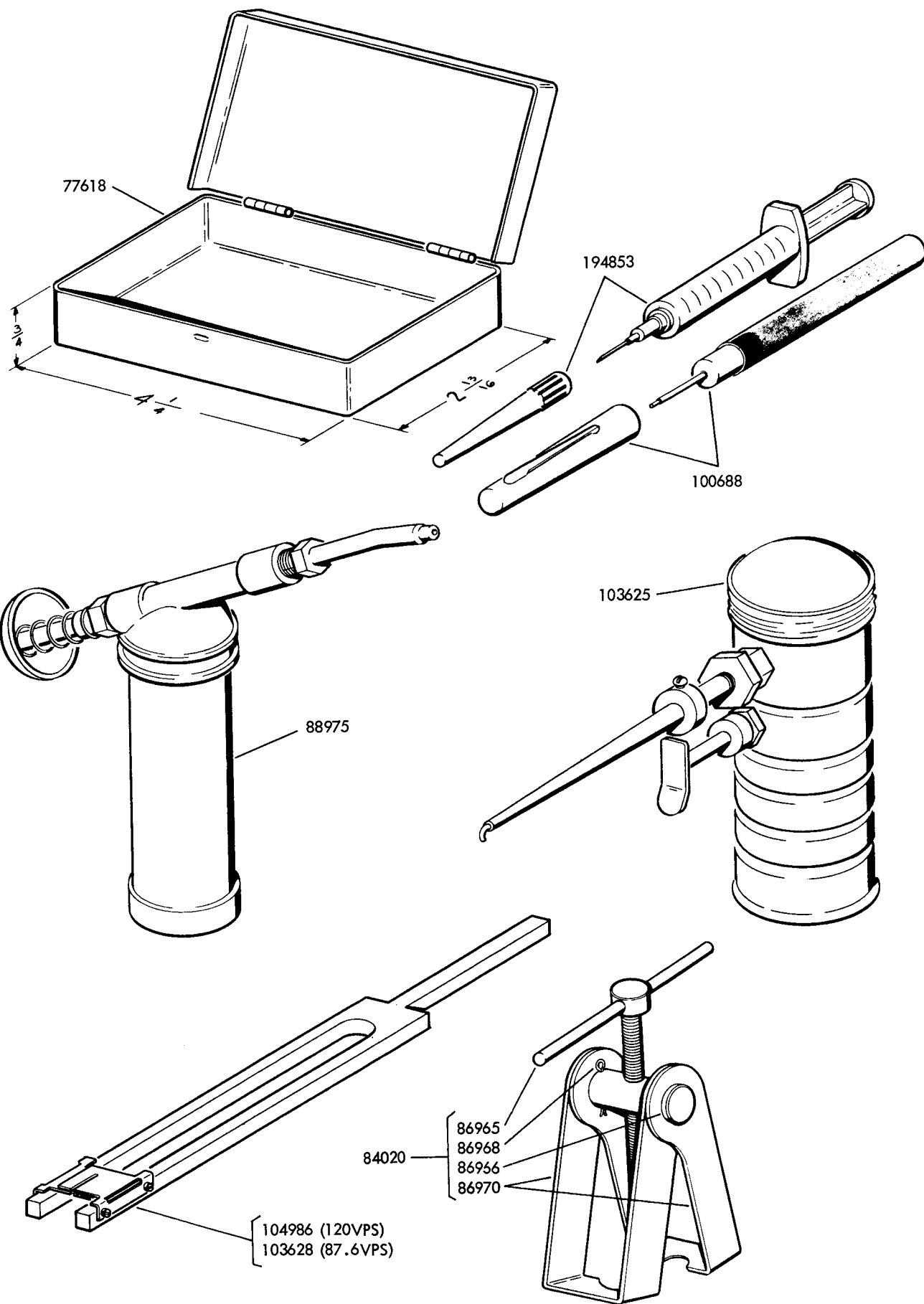

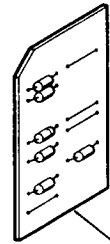
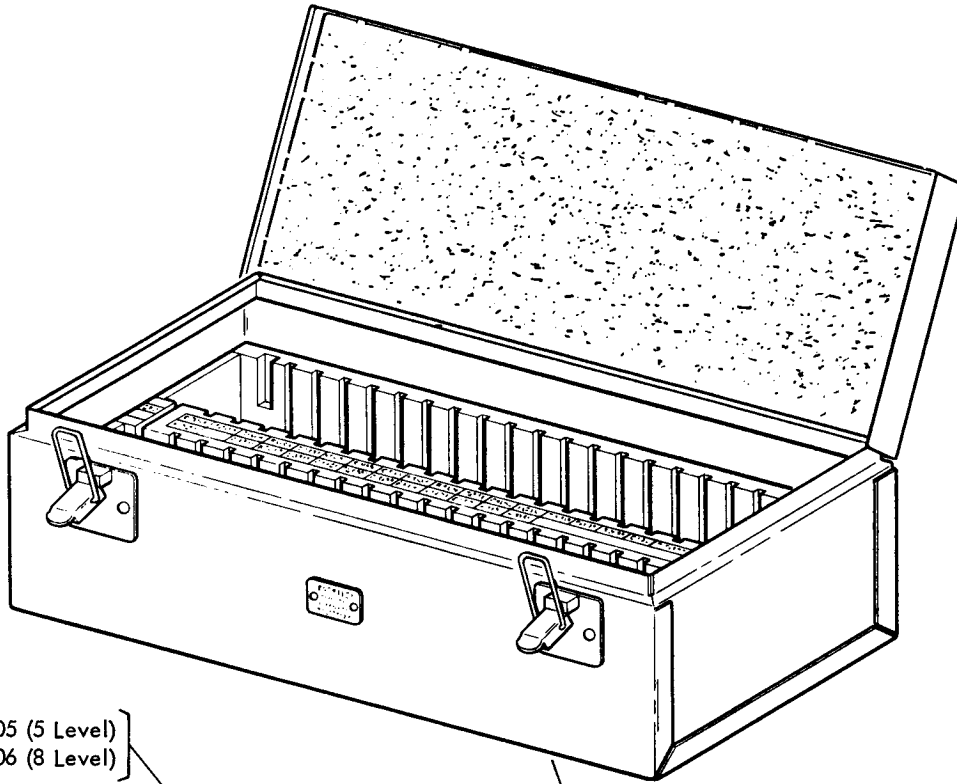

Circuit Card
See Chart

146605 (5 Level)
146606 (8 Level)

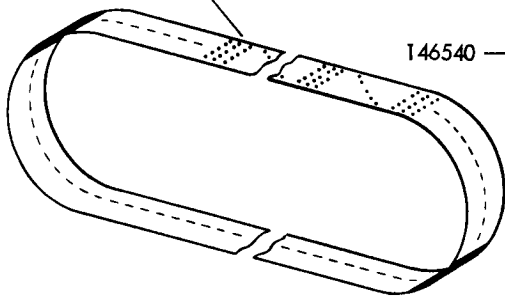

146540 } 146538

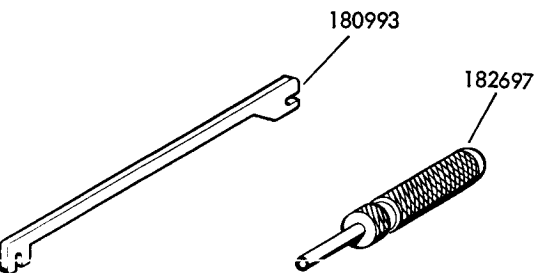
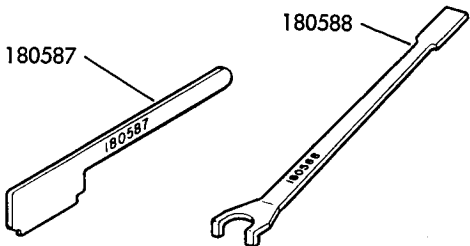

146539 Spare Circuit Card Kit			
Designation	Part Number	Designation	Part Number
EC321	172321	EC374	172374
EC322	172322	EC375	172375
EC323	172323	EC385	172385
EC324	172324	EC394	172394
EC325	172325	EC395	172395
EC326	172326	EC396	172396
EC333	172333	EC401	172401
EC347	172347	EC420	172420
EC351	172351	EC431	172431
EC352	172352	EC469	172469
EC355	172355	EC473	172473
EC359	172359	EC475	172475
EC361	172361	EC490	172490
EC363	172363	EC520	146520
EC365	172365	EC521	146521

172450 Extension Card Assembly

TOUCH UP PAINT - 1 PINT					
Air Dry Brush Enamel					
Smooth Finish			Wrinkle Finish		
Color	Teletype Code	Part Number	Color	Teletype Code	Part Number
Black High Gloss	BA	143431	Black	AA	120820
Black Semi-Gloss	BB	143432	Gray Green	AB	120821
Light Gray (Coast Guard)	BH	143433	Light Brown	AC	120822
Light Gray (Navy)	BU	143435	Dark Brown	AD	120823
Light Gray	BR	143435			
Charcoal Gray	BZ	143436			
Navy Ocean Gray	ED	143437			
Gray Green	BK	143434			

LUBRICANTS					
Grease			Oil		
Quantity	Part Number	Bell System Code	Quantity	Part Number	Bell System Code
4 Oz. Tube	97116	KS7471	1 Qt. Can	88970	KS7470
1 Lb. Can	88973	KS7471	1 Gal. Can	88971	KS7470
5 Lb. Can	88974	KS7471	5 Gal. Can	88972	KS7470
4 Oz. Tube	*145867				
1 Lb. Can	*143484				

*For High Speed Punch and Reader

CLEANING AGENT (Metal Parts)	
Quantity	Part Number
1 Gal. Can	101431
5 Gal. Can	112532

ADHESIVE		
Quantity	Application	Part Number
4 Oz.	Felt Pads	143285
1 Pint	Rubber Pads	163584

TOOL KITS

113778 Universal Tool Kit contains the following:

Part Number	Description	Page Number	Part Number	Description	Page Number
6617	Wrench, tommy	3	110443	Scale, spring - 8 oz.	2
72003	Bender, spring	6	110444	Scale, spring - 32 oz.	2
72574	Tool, finger holding	6	113756	Wrench Set	2
72575	Tool, finger bending	6	113777	Tool Kit	2
72581	Pin, gauge	6	116156	Wrench, spanner	3
73370	Gauge, selector sword	7	117781	Gauge Set	4
73404	Wrench, tommy	3	124134	Bender, spring	6
73408	Magnifier	4	124682	Wrench, hex key	3
75503	Hook, spring - push	4	125752	Wrench, socket - 3/16	3
75765	Hook, spring - pull	4	129848	Screwdriver	3
77618	Box, tool	8	135059	Scale, spring - 15 lbs.	2
82711	Scale, spring - 64 oz.	2	142554	Hook, spring - pull	4
87698	Stone, carborundum	3	142555	Hook, spring - push	4
88993	Burnisher, contact	3	151351	Hook, spring - pull (heavy duty)	4
91117	File, contact	3	151384	Holder, screw	3
94644	Screwdriver, offset	3	151392	Tweezers	4
94645	Screwdriver, offset	3	151959	Hook, spring - pull	4
95368	Screwdriver	3	152223	Scale, spring - 70 grams	2
95960	Gauge, tape	7	152292	Clip, armature	5
99947	Tool, punch block cleaning	7	159841	Wrench, hex key	3
104457	Wrench, hex key	3	161686	Tool, uncoded function bar	5
110271	Wrench, hex key	3			

TOOL KITS (Continued)

151940 Special Tool Set (Model 28 Page Printer Set) contains the following :

Part Number	Description	Page Number	Part Number	Description	Page Number
73408	Magnifier	4	151392	Tweezers	4
100982	Screwdriver	3	151394	Brush	4
151351	Hook, spring - pull (heavy duty)	4	151959	Hook, spring - pull	4
151382	Screwdriver	3	152835	Wrench, open end	2
151383	Remover, keylever	5	152837	Wrench, open end	2
151384	Holder, screw	3			

159114 Tool Kit For Model 28 equipment contains the following:

Part Number	Description	Page Number	Part Number	Description	Page Number
104457	Wrench, hex key	3	159133	Gauge, top plate	7
129537	Wrench, open end	2	159841	Wrench, hex key	3
156011	Gauge, tape	7	159926	Gauge W/Pin, bail arm	7
156170	Bender, spring	6	160396	Pliers, retaining ring	3
156743	Gauge, tape lid	6			

171312 Tool Set for high speed tape punch and tape reader contains the following :

Part Number	Description	Page Number	Part Number	Description	Page Number
82711	Scale, spring - 64 oz.	2	110445	Bender, spring	6
88970	Oil	8	113756	Wrench Set	2
88993	Burnisher, contact	3	117781	Gauge Set	4
89954	Wrench, socket	3	129534	Wrench, open end	2
89955	Wrench, socket	3	142554	Hook, spring - push	4
94644	Screwdriver, offset	3	142555	Hook, spring - pull	4
94645	Screwdriver, offset	3	143089	Clip, armature	7
94646	Stick, orangewood	7	143484	Grease - 1 lb.	8
94647	Screwdriver	3	151384	Holder, screw	3
95960	Gauge, tape	7	151392	Tweezers	4
99947	Tool, punch block cleaning	7	152223	Scale, spring - 70 grams	2
100704	Screwdriver	3	159841	Wrench, hex key	3
103625	Can, oil	8	172060	Bender, contact	6
104457	Wrench, hex key	3			
110442	Screwdriver	3			
110443	Scale, spring - 8 oz.	2			
110444	Scale, spring - 32 oz.	2			

NUMERICAL INDEX

Part Number	Description and Page Number	Part Number	Description and Page Number
6617	Wrench, Tommy 3, 10	96383	Gauge 4
7002	Washer, Flat 5	96385	Gauge 4
72003	Bender, Spring 6, 10	96389	Gauge 4
72574	Tool, Finger Holding 6, 10	96391	Gauge 4
72581	Pin, Gauge 6, 10	96393	Gauge 4
73370	Gauge, Selector Sword 7, 10	96399	Gauge 4
73404	Wrench, Tommy 3, 10	96401	Gauge 4
73408	Magnifier 4, 10, 11	96403	Gauge 4
73409	Brush, Camels Hair 4	96405	Gauge 4
73410	Screwdriver 3	97115	Grease 10
73517	Gauge, Feed Roll Positioning 7	98055	Bender, Spring 6
75503	Hook, Spring - Push 4, 10	98136	Gauge 4
75765	Hook, Spring - Pull 4, 10	99391	Gauge, Switching Contacts 6
75906	Tool, Local Test 7	99947	Tool, Punch Block Cleaning 7, 10, 11
77618	Case, Tool 8, 10	100688	Oiler 8
78590	Pliers, Parallel 3	100704	Screwdriver 3, 11
82711	Scale, Spring - 64 oz. 2, 11	100982	Screwdriver 3, 11
84020	Puller, Bearing 8	101082	Wrench, Open End - 3/4" 7
86965	Handle 8	101431	Cleaner 10
86966	Shaft 8	103534	Tool, Bending 6
86968	Pin, Cotter 8	103625	Can, Oil 8, 11
86970	Jaw, Bearing Puller 8	104457	Wrench, Hex Key 3, 10, 11
87698	Stone, Carborundum 3, 10	104986	Fork, Tuning 8
88970	Oil 10, 11	108252	Screwdriver 3
88971	Oil 10	108285	Pliers, Long Nosed 2
88972	Oil 10	108286	Pliers, Cutting 3
88975	Gun, Grease 8	110271	Wrench, Hex Key 3, 10
88993	Burnisher, Contact 3, 10, 11	110442	Screwdriver 3, 11
89954	Wrench, Socket - 1/4" 3, 11	110443	Scale, Spring - 8 oz. 2, 10, 11
89955	Wrench, Socket - 5/16" 3, 11	110444	Scale, Spring - 32 oz. 2, 10, 11
91117	File, Contact 3, 10	110445	Bender, Spring 6, 11
93809	Gauge Set 4	112532	Cleaner 10
93811	Gauge 4	113756	Wrench Set 2, 10, 11
93814	Holder, Gauge 4	113777	Tool Kit 2, 10
93822	Gauge 4	113778	Tool Kit 10
93823	Gauge 4	114199	Bender, Spring 6
93824	Gauge 4	114200	Bender, Spring 6
93825	Gauge 4	116156	Wrench, Spanner 3, 10
93827	Gauge 4	116799	Tool, Bending 6
93828	Gauge 4	117375	Case, Gauge 4
93833	Gauge 4	117781	Gauge Set 4, 10, 11
94540	Screw, Set 4	118530	Gauge 6
94644	Screwdriver, Offset - 30° 3, 10, 11	120820	Paint 10
94645	Screwdriver, Offset - 90° 3, 10, 11	120821	Paint 10
94646	Stick, Orangewood 7, 11	120822	Paint 10
94647	Screwdriver 3	120823	Paint 9
95368	Screwdriver 3, 10	121038	Wrench, Closed Spanner 3
95960	Gauge, Tape 7, 10, 11	121550	Bender, Spring 6
96356	Gauge 4	124134	Bender, Spring 6, 10
96358	Gauge 4	124682	Wrench, Hex Key 3, 10
96360	Gauge 4	124828	Pad, Maintenance (Nylon Fiber) 5
96362	Gauge 4	125752	Wrench, Socket - 3/16" 3, 10
96364	Gauge 4	125754	Wrench, Socket - 1/4" 7
96369	Gauge 4	125765	Wrench, Open End - 7/16 x 3/8 7
96371	Gauge 4	125777	Wrench, Open End - 1/4 7
96373	Gauge 4	129534	Wrench, Open End - 3/16 x 1/4 2, 11
96375	Gauge 4	129535	Wrench, Open End - 5/8 x 3/4 2
96377	Gauge 4	129536	Wrench, Open End - 7/16 x 1/2 2

NUMERICAL INDEX (Continued)

Part Number	Description and Page Number	Part Number	Description and Page Number
129537	Wrench, Open End - 9/16 x 3/4 2, 11	159114	Tool Kit 11
129848	Screwdriver 3, 10	159133	Gauge, Top Plate 7, 11
135059	Scale, Spring - 15 lb. 2, 10	159358	Tool Kit 5
135060	Roll, Leatherette Tool 2	159841	Wrench, Hex Key 3, 10, 11
135675	Roll, Leatherette Tool 2	159926	Gauge, Bail Arm 7, 11
135676	Handle 2	160396	Pliers, Retaining Ring 3, 11
135677	Wrench, Socket - 1/4 2	161430	Handwheel 5
135678	Wrench, Socket - 5/16 2	161686	Tool, Function Bar 5
135679	Blade, Adjusting 2	163584	Adhesive 10
135680	Blade, Adjusting 2	170283	Gauge, Tape Lid 6
139676	Drill 7	170311	Gauge, Tape Lid 6
142554	Hook, Spring - Pull 4, 10, 11	171312	Tool Set 11
142555	Hook, Spring - Push 4, 10, 11	172060	Bender, Spring 6, 11
143089	Clip, Armature 7, 11	172321	Card, Circuit 9
143285	Adhesive 10	172322	Card, Circuit 9
143431	Paint 10	172323	Card, Circuit 9
143432	Paint 10	172324	Card, Circuit 9
143433	Paint 10	172325	Card, Circuit 9
143434	Paint 10	172326	Card, Circuit 9
143435	Paint 10	172333	Card, Circuit 9
143436	Paint 10	172347	Card, Circuit 9
143437	Paint 10	172351	Card, Circuit 9
143484	Grease 10, 11	172352	Card, Circuit 9
145867	Grease 10	172355	Card, Circuit 9
146330	Iron, Soldering 5	172359	Card, Circuit 9
146331	Tip, Soldering Iron 5	172361	Card, Circuit 9
146520	Card, Circuit 9	172363	Card, Circuit 9
146521	Card, Circuit 9	172365	Card, Circuit 9
146538	Case, Circuit Card 9	172374	Card, Circuit 9
146539	Kit, Circuit Card 9	172375	Card, Circuit 9
146540	Kit and Case, Circuit Card 9	172385	Card, Circuit 9
146605	Tape, Test (5 level) 9	172394	Card, Circuit 9
146606	Tape, Test (8 level) 9	172395	Card, Circuit 9
150040	Screw (6-40 x 5/8 Fil) 5	172396	Card, Circuit 9
151351	Hook, Spring - Pull (Heavy Duty) 4, 10, 11	172401	Card, Circuit 9
151382	Screwdriver 3, 11	172420	Card, Circuit 9
151383	Remover, Keylever 5, 11	172431	Card, Circuit 9
151384	Holder, Screw 3, 10, 11	172450	Extension Card Assembly 9
151392	Tweezers 4, 10, 11	172469	Card, Circuit 9
151394	Brush 4, 11	172473	Card, Circuit 9
151627	Rod 5	172475	Card, Circuit 9
151940	Tool Set 11	172490	Card, Circuit 9
151959	Hook, Spring - Pull 4, 10, 11	173503	Gauge, Tape Lid 6
152223	Scale, Spring - 70 gram 2, 10, 11	178489	Clip, Armature 5
152258	Post 5	178902	Gauge, Tape 7
152292	Clip, Armature 5, 10	179407	Gauge, Feeler (.090) 4
152835	Wrench, Open End - 5/16 x 3/8 2, 11	179408	Gauge, Feeler (.100) 4
152837	Wrench, Open End - 3/16 x 1/4 2, 11	179409	Gauge, Feeler (.110) 4
153673	Shaft 5	179410	Gauge, Feeler (.120) 4
153797	Depressor, Sprocket Pin 5	179411	Gauge Set 4
153807	Post 5	180587	Tool, Carriage Adjusting 9
153808	Clamp 5	180588	Tool, Typewheel Adjusting 9
154393	Wrench, Open End - 5/32 2	180993	Bender 9
156011	Gauge, Tape 7, 11	181465	Adaptor, Handwheel 5
156170	Bender, Spring 6, 11	182697	Extractor, Terminal 9
156743	Gauge, Tape Lid 6, 11	194853	Injector, Oil 8

