

symbol of leadership



in printing telegraphy

BULLETIN 1075B

PARTS  
TAPE WINDERS  
AND  
CENTER UNWIND REELS

**TELETYPE<sup>®</sup>**  
**CORPORATION**  
SUBSIDIARY OF *Western Electric Company* INC.  
CHICAGO, ILLINOIS, U. S. A.

Printed in U.S.A.



## LIST OF EFFECTIVE PAGES

OCTOBER, 1959

(Supersedes October, 1957 Issue)

Page Number	Change In Effect
A to B	Change 2
1 to 2	Original
3	Change 1
4 to 5	Original
6	Change 2
7 to 9	Change 1
10	Change 2
11 to 12	Change 1
13 to 23	Change 2

The above list indicates the effective pages as of the date of issue. Upon receipt of change pages, insert them numerically and discard any superseded pages.

## MOTOR DRIVEN TAPE WINDERS

TELETYPE CODE OR PART NUMBER. BELL SYSTEM CODE IN PARENTHESIS	NUMBER OF TAPE REELS	TAPE WIDTH IN INCHES	CORE DIAMETER IN INCHES	CUP DIAMETER IN INCHES	CAPACITY OF REELS		FLOOR SPACE IN INCHES	HEIGHT IN INCHES	NOTES	SHOWN ON PAGES
					FULLY PUNCHED (FEET)	CHAD-LESS (FEET)				
TW3	2	11/16	3	—	2000	1000	725X16	17.5		1,2,4,5 & 6
Ⓐ TW4	1	11/16	3	—	2000	1000	6.18X16	17.5		1,2,4,5 & 6
Ⓑ TW5 (2A)	1	11/16	3	—	2000	1000	6.18X16	17.5		1,2,4,5 & 6
TW5 + (2B) 115743AD	1	11/16	3	—	2000	1000	—	—		1,2,4,5,6 & 19
TW6 (1A)	2	11/16	3	—	2000	1000	7.25X16	17.5		1,2,4,5 & 6
TW8	1	3/8	3	—	2000	1000	6.18X16	17.5		1,2,4 & 6
TW9	2	3/8	3	—	2000	1000	7.25X16	17.5		1,2,4 & 6
TW10 (3A)	3	11/16	3	—	2000	1000	11.5X16	17.5		1,2,3,4,5 & 6
Ⓒ TW12	1	11/16	2	—	2000	1000	5X20.5	12.75		7,8,9 & 10
Ⓓ TW13 (4A)	1	11/16	2	—	2000	1000	5X20.5	12.75		7,8,9 & 10
TW200**	1	3/8	3	—	500	250	5.5X11	9.25	FORMERLY TW11 (GRAY GREEN WRINKLE)	11,12 & 13
		15/32	3	—	500	250	5.5X11	9.25		
		11/16	3	—	500	250	5.5X11	9.25		
		7/8	3	—	500	250	5.5X11	9.25		
TW201**	1	7/8	2-5/8	—	90	50	5.25X11	9.25		11,12 & 13

## SPRING DRIVEN TAPE WINDERS (SINGLE REEL)

115739**	1	7/8	2-3/4	—	90	50	6X6.75	6	FORMERLY 85832 (WALNUT)	14 & 15, FIG. 2
115753**	1	11/16	2-3/4	—	180	100	6X6.75	6	FORMERLY 103032 (WALNUT)	14 & 15, FIG. 3
115754**	1	11/16	2-3/4	—	90	50	6X6.75	6	FORMERLY 91729 (WALNUT)	14 & 15, FIG. 1
123587**	1	3/8	1-1/8	—	500	—	6X6.75	6.75	FORMERLY 93791 (BLACK) AND 104478 (BLACK WRINKLE)	14 & 15, FIG. 4
		1/2	1-1/8	—	500	—	6X6.75	6.75		
		11/16	1-1/8	—	400	150	6X6.75	6.75		
124884**	1	7/8	2-3/4	—	180	100	6X6.75	6.75	FOR 6 UNIT TAPE	14 & 16, FIG. 5

## CENTER UNWIND REELS

91819	1	7/8 OR LESS	2-5/8	4.5	90	50	4.5 DIA.	—	ARRANGED TO MOUNT ON A BELL SYSTEM 19A TABLE.	17
103035	1	7/8 OR LESS	2-5/8	6.216	180	100	6.25 DIA	—	ARRANGED TO MOUNT ON A BELL SYSTEM 19A TABLE.	17
114189	1	7/8 OR LESS	2-5/8	6.216	180	100	6.25 DIA	4	SIMILAR TO 103035 EXCEPT ARRANGED TO MOUNT ON A TRANSMITTER DIST. COVER	17
116836	1	7/8 OR LESS	2-5/8	6.312	180	100	6.312 DIA			16

ⒶⒷ TW4 AND TW5 DIFFER AS TW5 HAS INNER AND OUTER BEARING PLATES AND TW4 HAS NONE. CORD ASSEMBLIES DIFFER AS INDICATED ON PAGE 6.

ⒸⒹ TW12 AND TW13 DIFFER IN TAPE ARM, BASE PLATE, CABLE AND TAPE REEL CORE AS INDICATED ON PAGES 7 AND 10.

BELL SYSTEM ONLY

When ordering parts from this bulletin, prefix each number with the letters TP.

## NOTE:

A double asterisk (\*\*) following a part or assembly number designates a two-letter suffix which denotes the paint finish. The following finishes are now available:

Black Wrinkle -AA Light Brown Wrinkle -AC  
Gray Green Wrinkle -AB Dark Brown Wrinkle -AD

In addition to the colors listed above other colors may be provided on request.

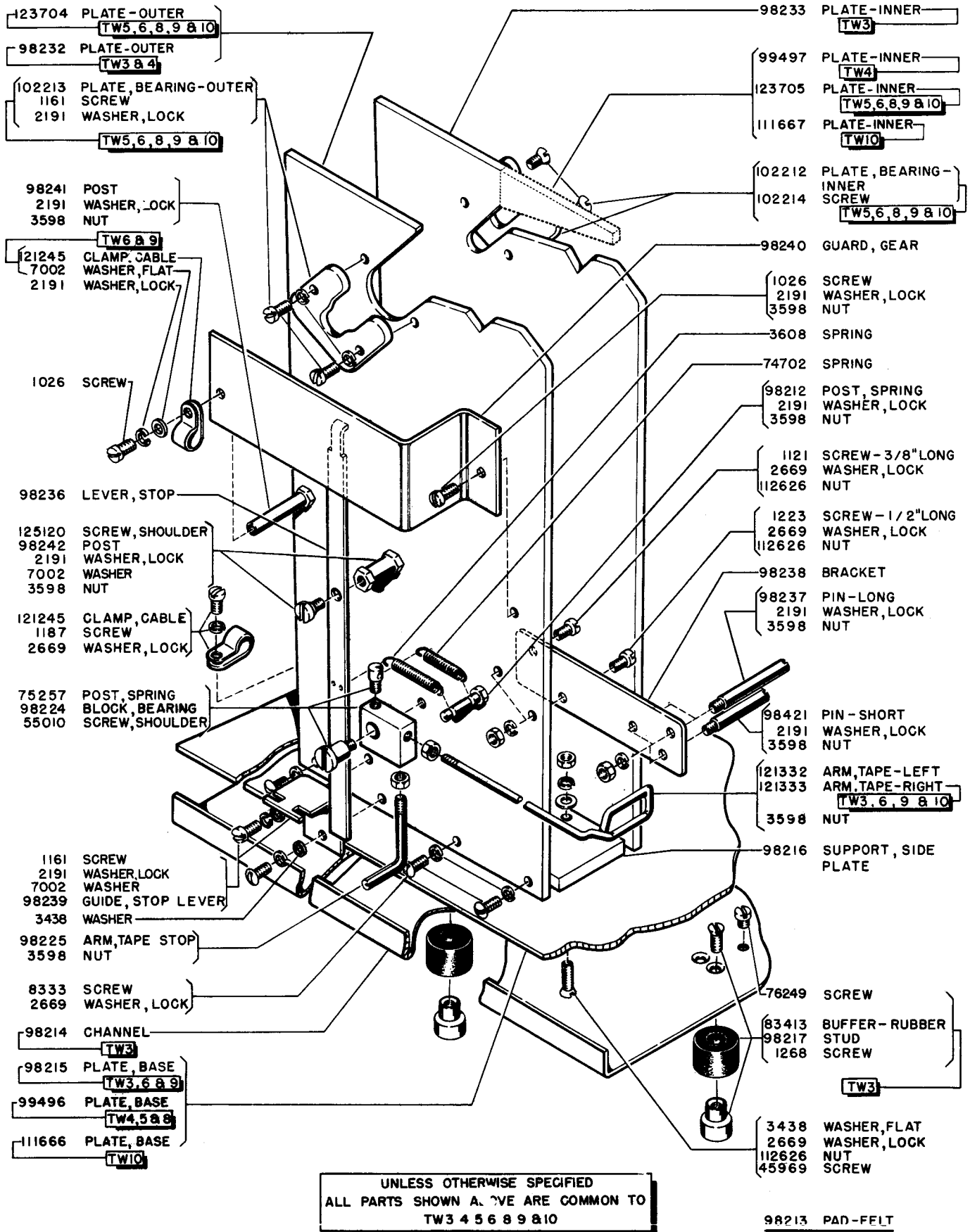

UNLESS OTHERWISE SPECIFIED  
ALL PARTS SHOWN ABOVE ARE COMMON TO  
TW3 4 5 6 8 9 & 10

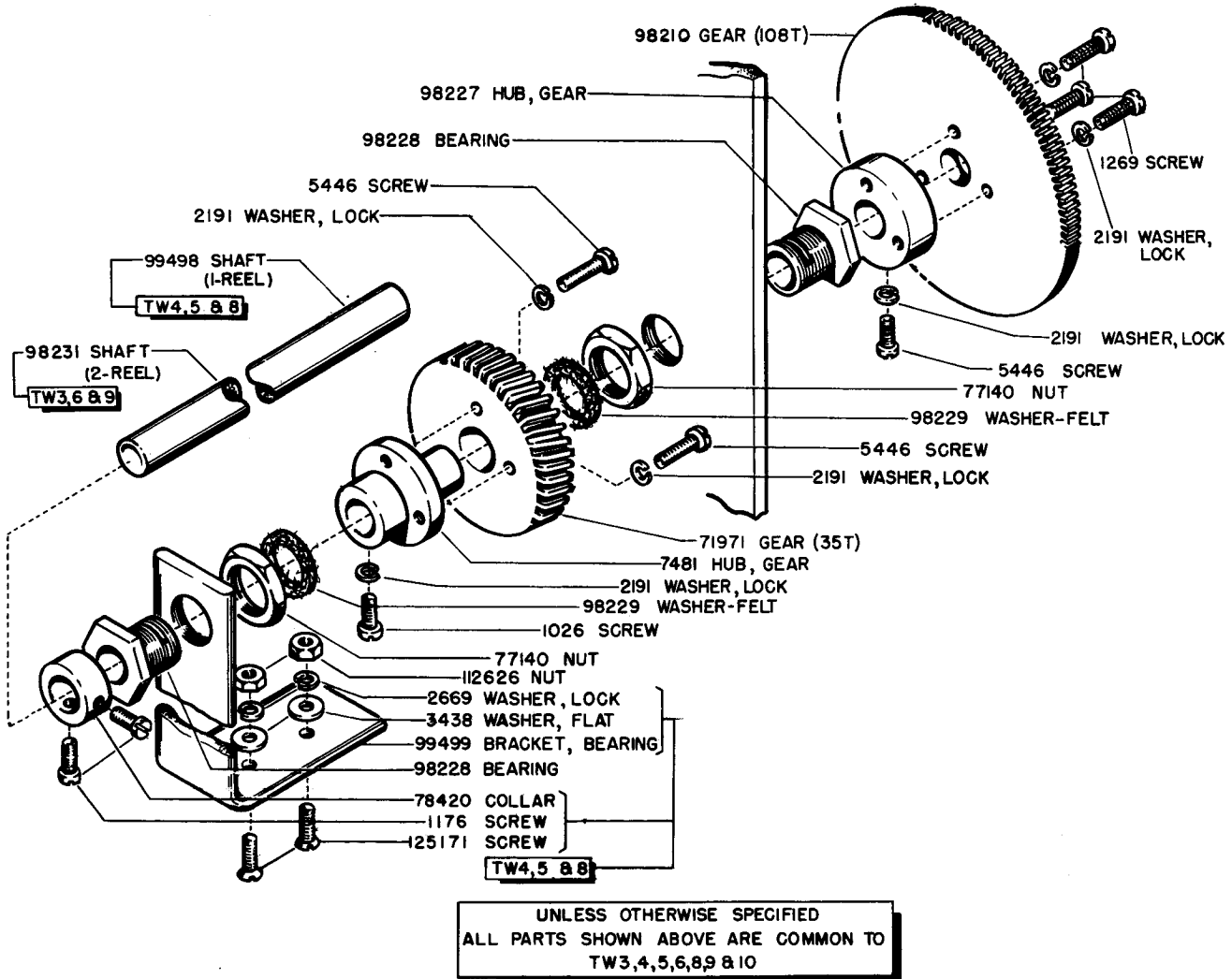
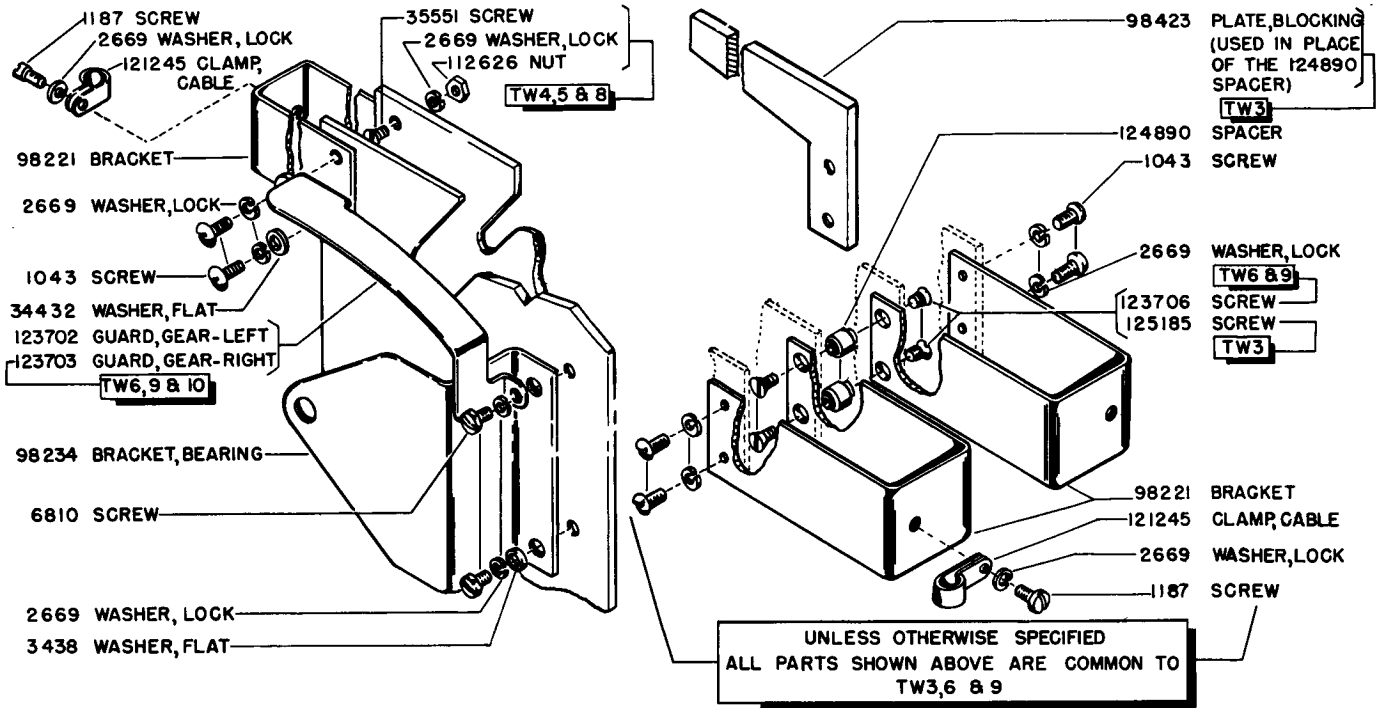

1075B

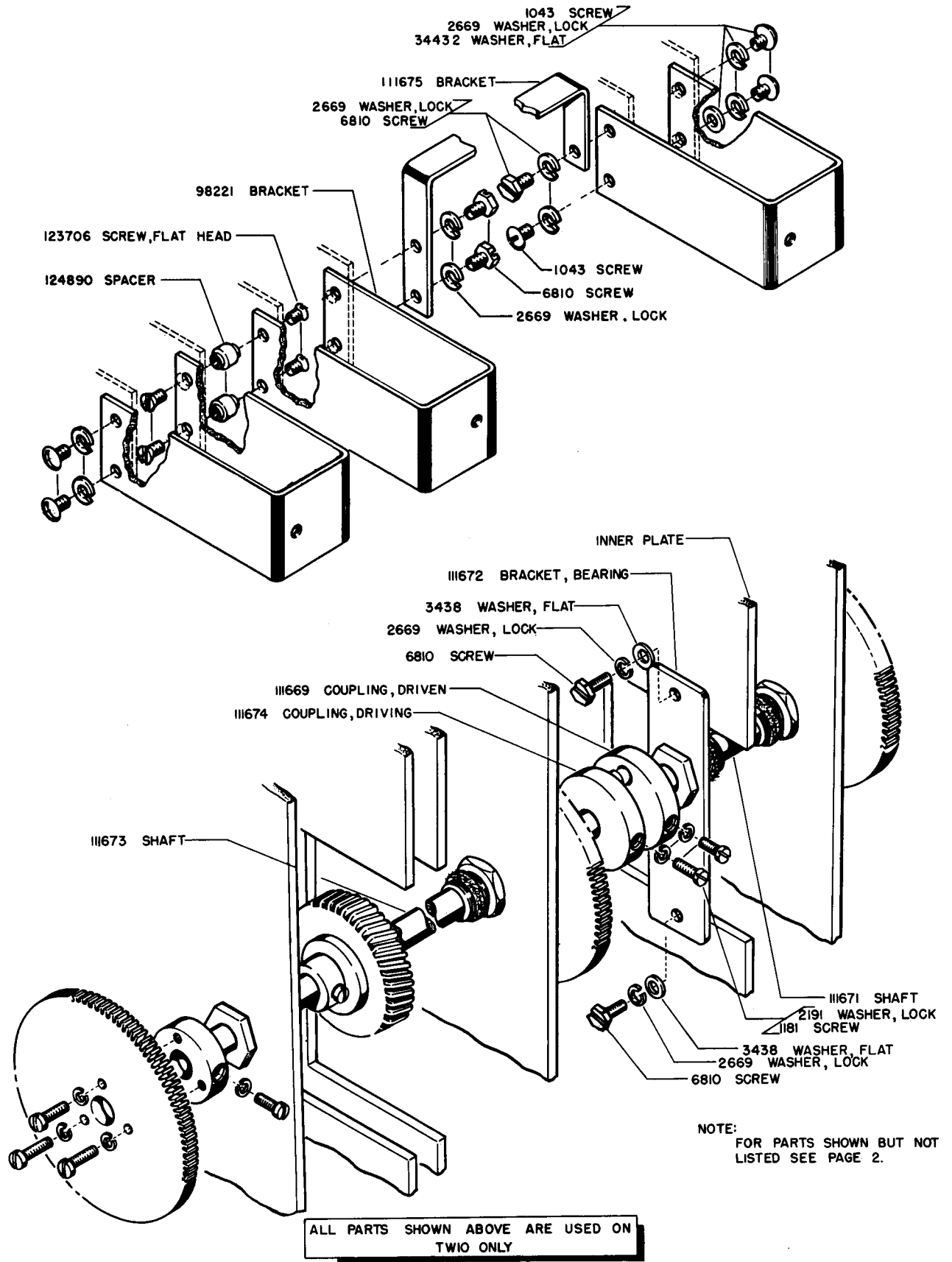

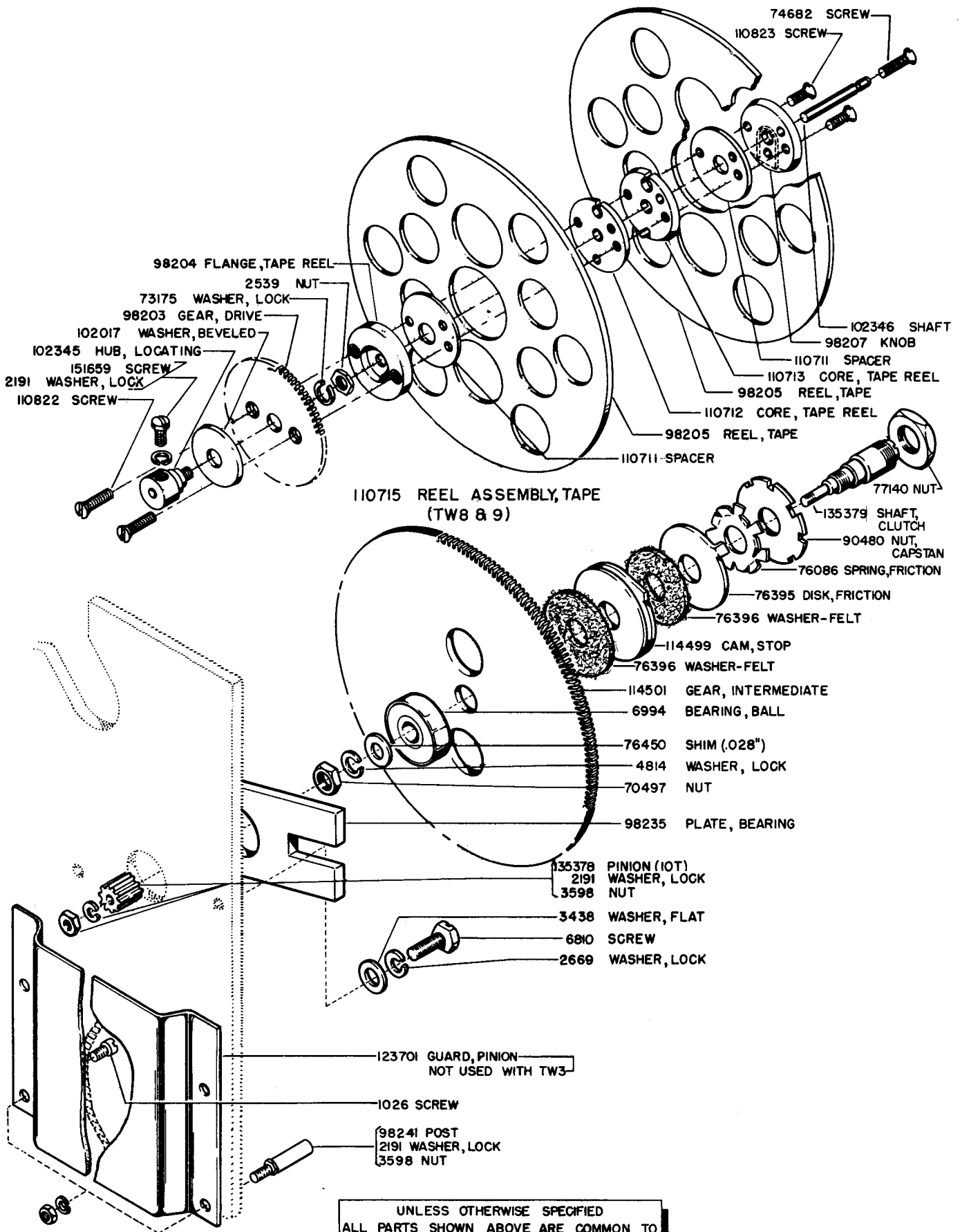

UNLESS OTHERWISE SPECIFIED  
 ALL PARTS SHOWN ABOVE ARE COMMON TO  
 TW3,4,5,6,8,9 & 10



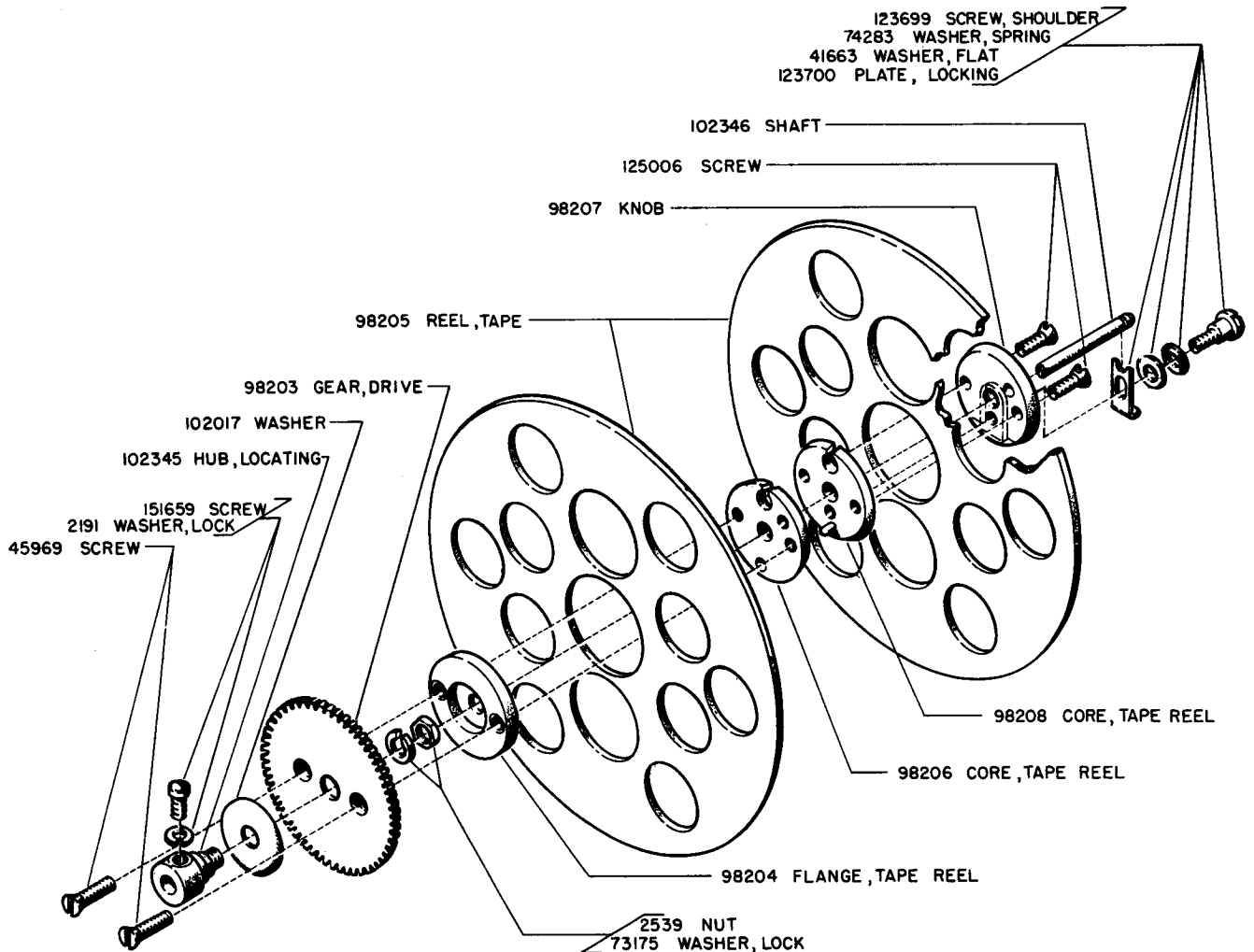

102073 REEL ASSEMBLY, TAPE  
TW5, 6, & 10

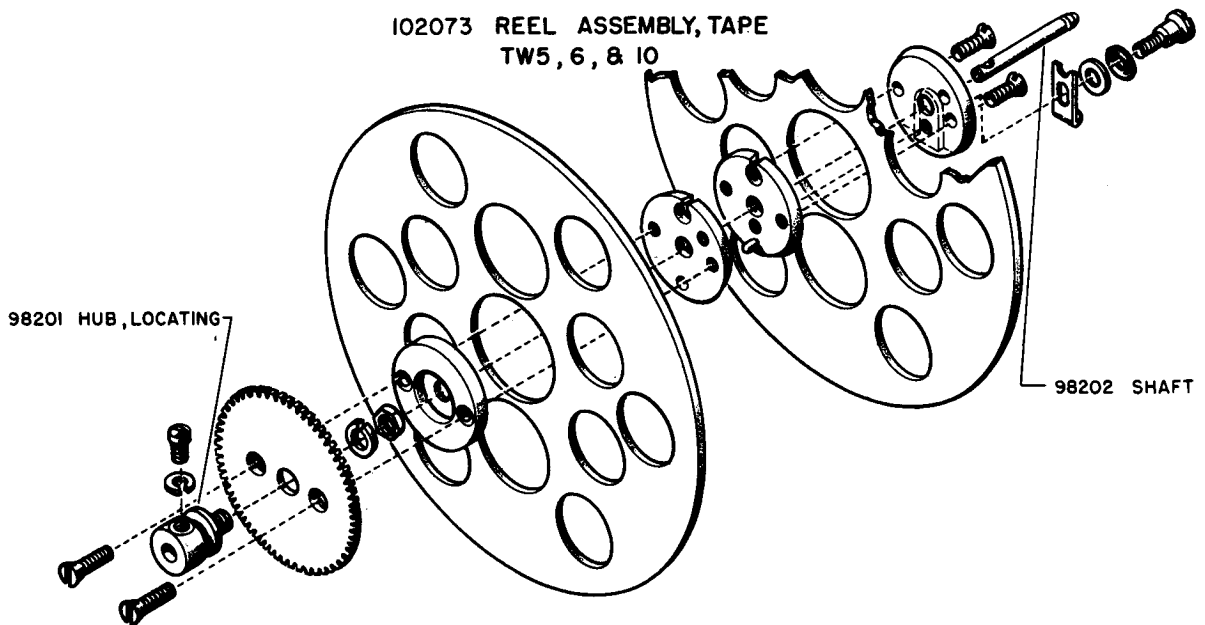

98200 REEL ASSEMBLY, TAPE  
TW3 & 4

(PARTS SHOWN BUT NOT LISTED SAME AS ABOVE)

10758

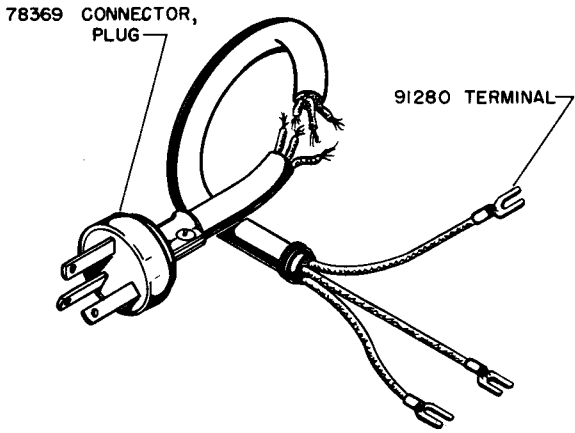

89437 CORD ASSEMBLY TW3

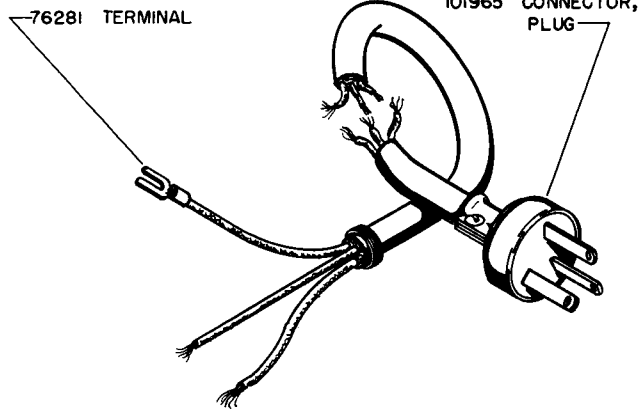

102495 CORD ASSEMBLY TW4, 6, 9, & 10

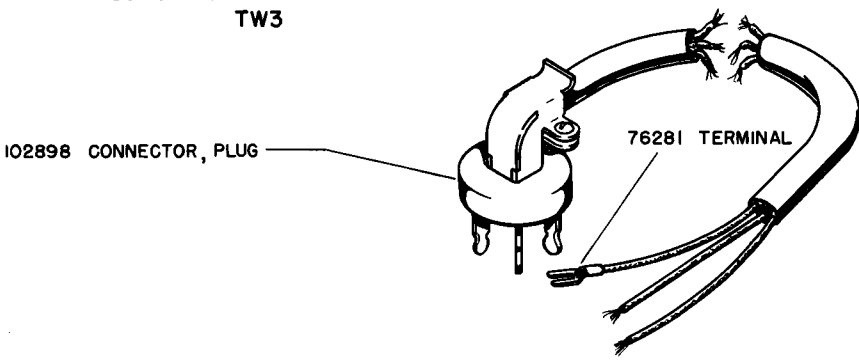

102899 CORD ASSEMBLY TW5 & 8

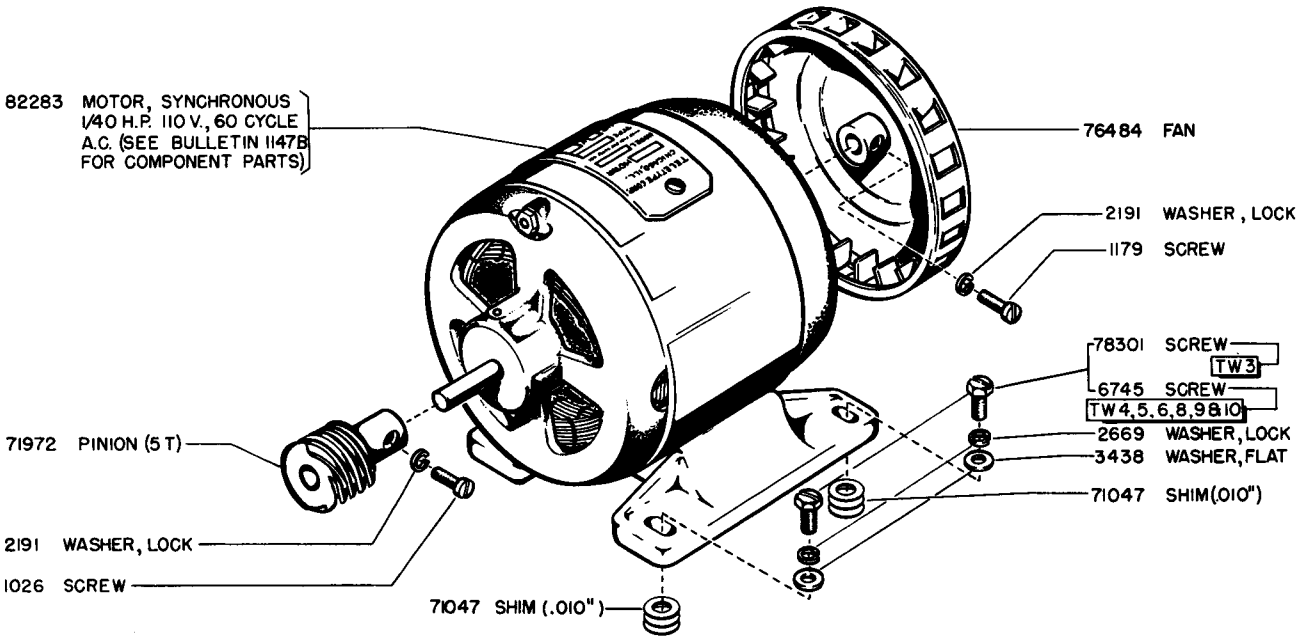

SYNCHRONOUS MOTOR

UNLESS OTHERWISE SPECIFIED  
 ALL PARTS SHOWN ABOVE ARE COMMON TO  
 TW3, 4, 5, 6, 8, 9 & 10

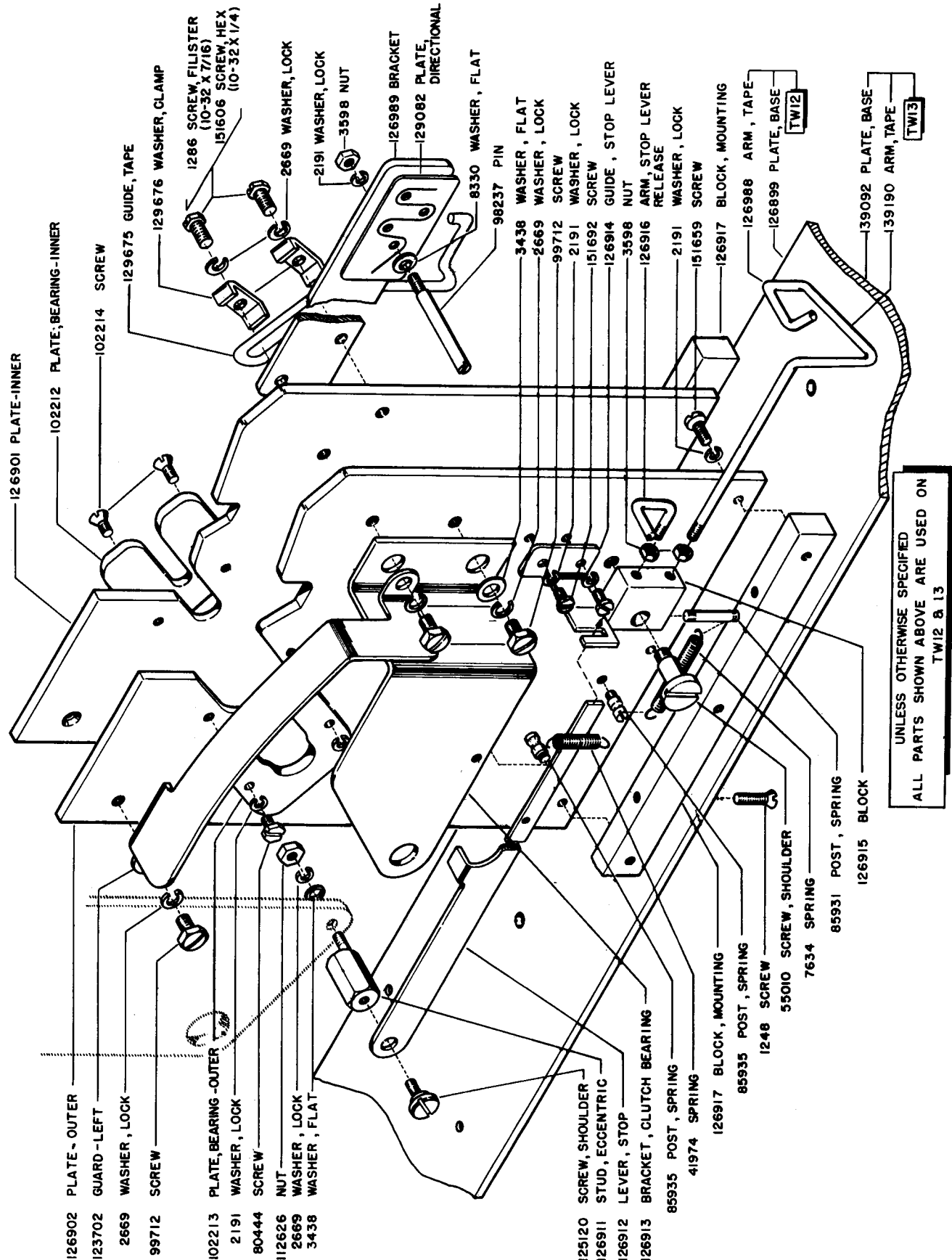

UNLESS OTHERWISE SPECIFIED  
 ALL PARTS SHOWN ABOVE ARE USED ON  
 TW12 & 13

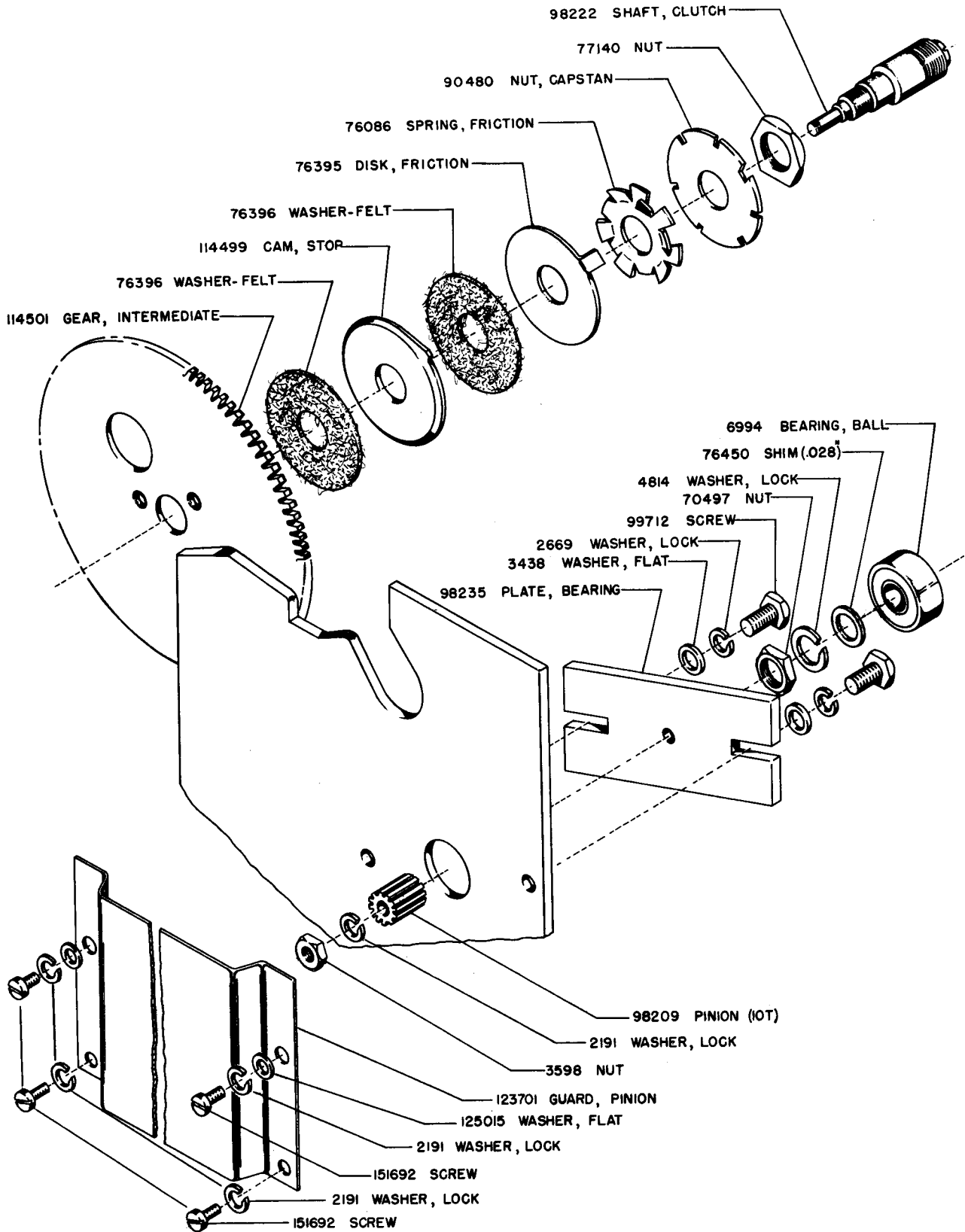

ALL PARTS SHOWN ABOVE ARE USED ON  
 TW12 & 13

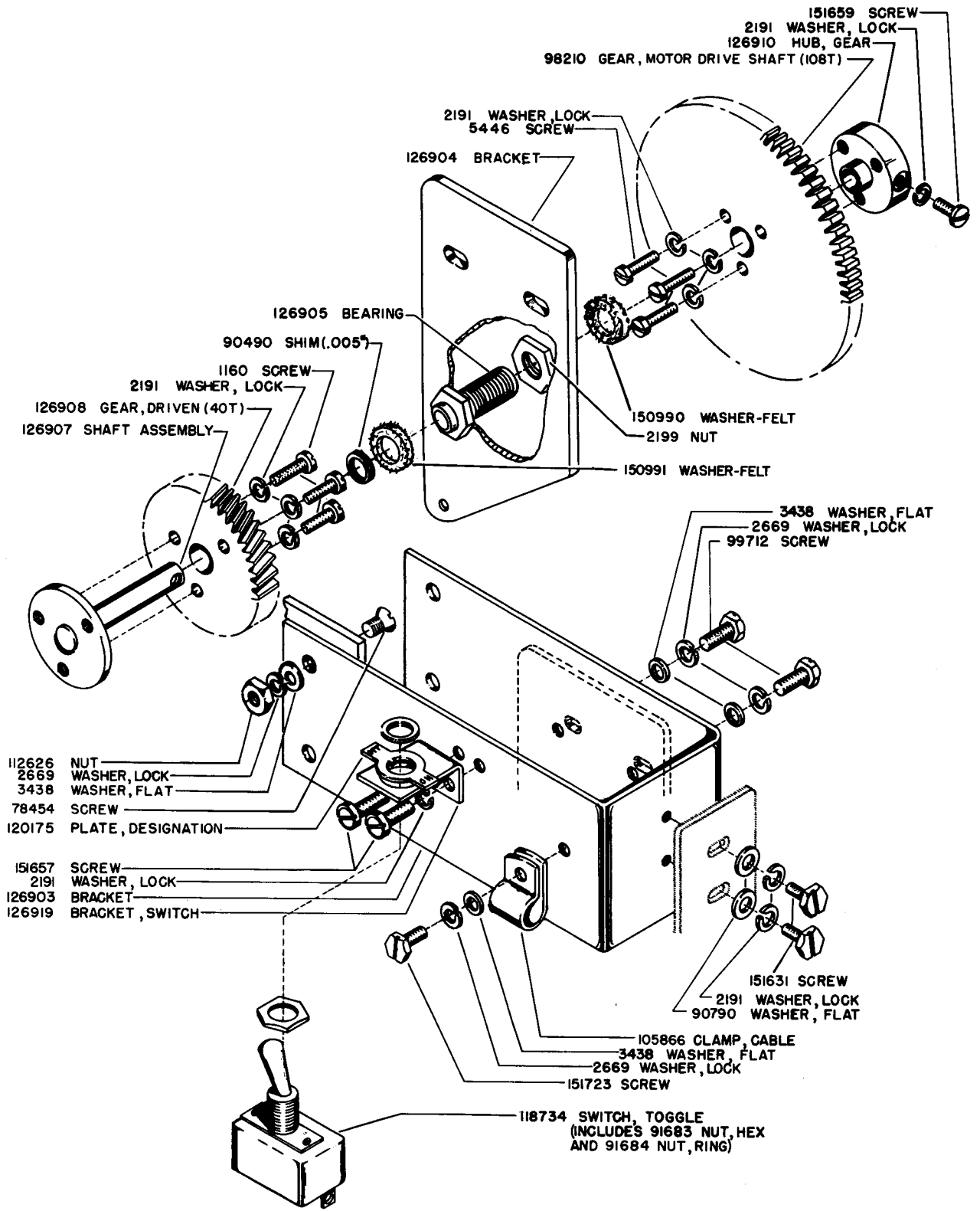

ALL PARTS SHOWN ABOVE ARE USED ON  
TW12 & 13

1075B

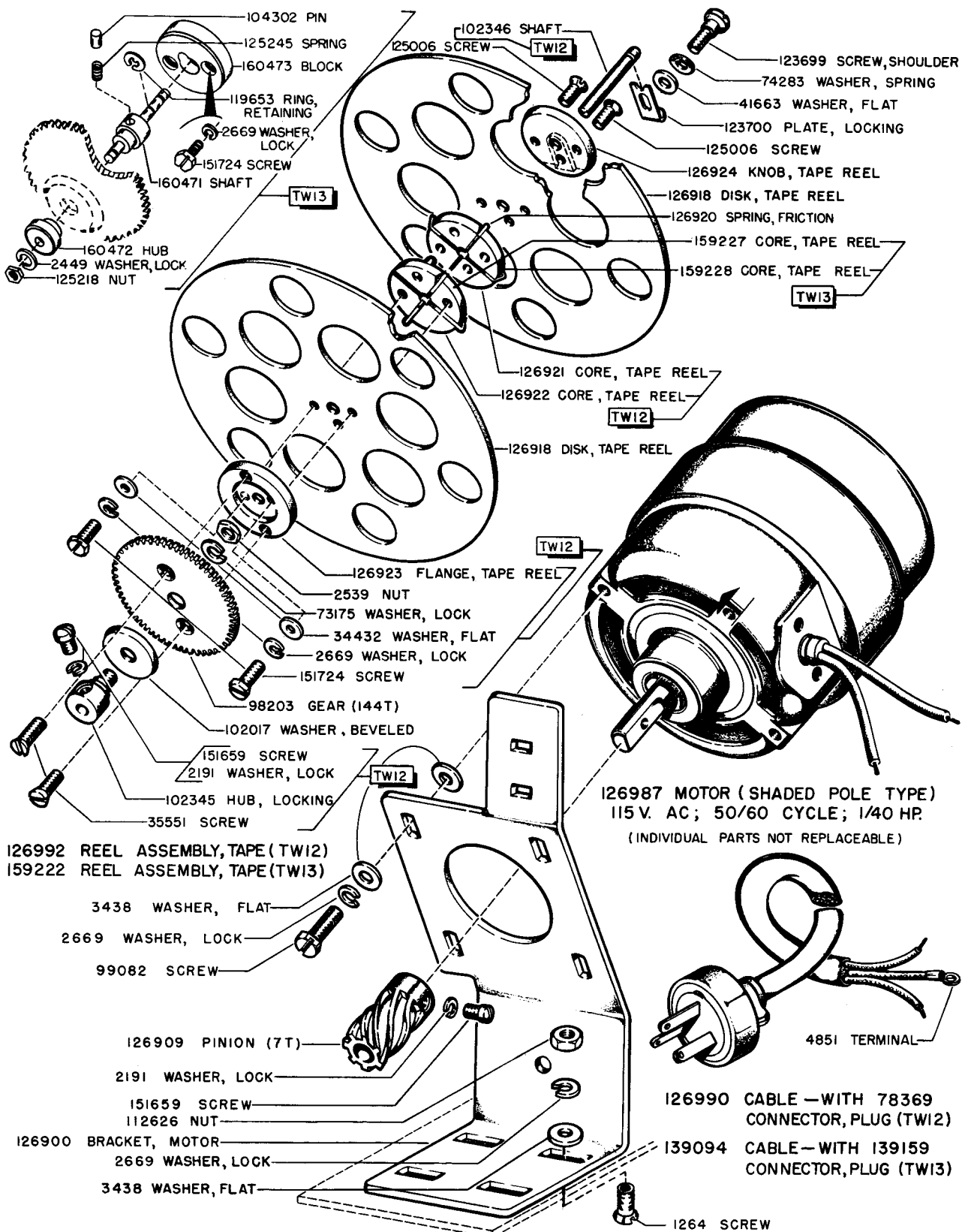

UNLESS OTHERWISE SPECIFIED  
 ALL PARTS SHOWN ABOVE ARE USED ON  
 TWI2 & 13

CHANGE 1

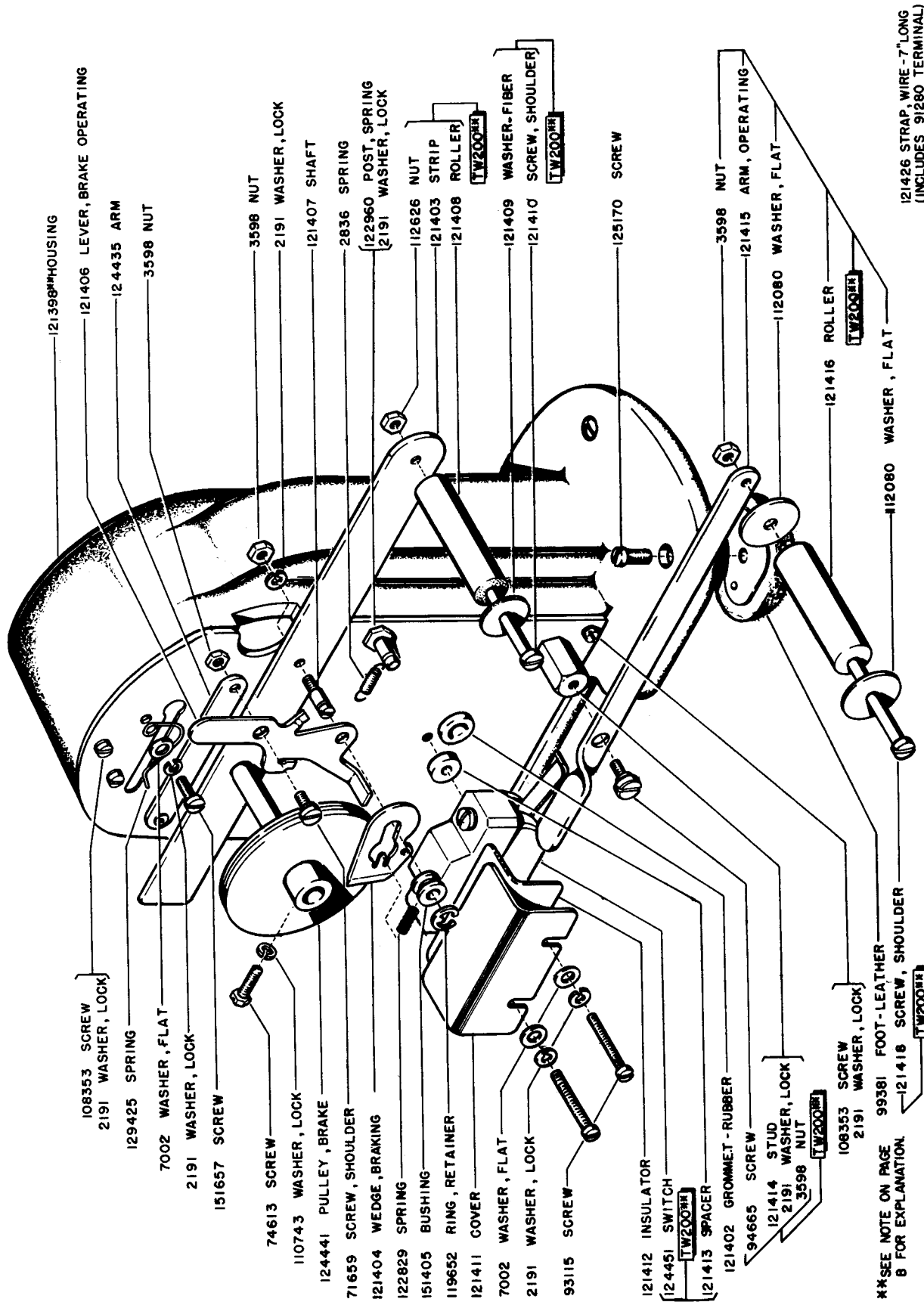

- 108353 SCREW
- 2191 WASHER, LOCK
- 129425 SPRING
- 7002 WASHER, FLAT
- 2191 WASHER, LOCK
- 151657 SCREW
- 74613 SCREW
- 110743 WASHER, LOCK
- 124441 PULLEY, BRAKE
- 71659 SCREW, SHOULDER
- 121404 WEDGE, BRAKING
- 122829 SPRING
- 151405 BUSHING
- 119652 RING, RETAINER
- 121411 COVER
- 7002 WASHER, FLAT
- 2191 WASHER, LOCK
- 93115 SCREW
- 121412 INSULATOR
- 124451 SWITCH
- 121413 SPACER
- 121402 GROMMET - RUBBER
- 94665 SCREW
- 121414 STUD
- 2191 WASHER, LOCK
- 3598 NUT
- 108353 SCREW
- 2191 WASHER, LOCK
- 99381 FOOT - LEATHER
- 121418 SCREW, SHOULDER
- 121398 HOUSING
- 121406 LEVER, BRAKE OPERATING
- 124435 ARM
- 3598 NUT
- 3598 NUT
- 2191 WASHER, LOCK
- 121407 SHAFT
- 2836 SPRING
- 122960 POST, SPRING
- 2191 WASHER, LOCK
- 12626 NUT
- 121403 STRIP
- 121408 ROLLER
- 121409 WASHER-FIBER
- 121410 SCREW, SHOULDER
- 125170 SCREW
- 3598 NUT
- 121415 ARM, OPERATING
- 112080 WASHER, FLAT
- 121416 ROLLER
- 112080 WASHER, FLAT

\*\*SEE NOTE ON PAGE 8 FOR EXPLANATION.

121426 STRAP, WIRE - 7" LONG  
(INCLUDES 91280 TERMINAL)

UNLESS OTHERWISE SPECIFIED  
ALL PARTS SHOWN ABOVE ARE COMMON TO  
TW200\*\* & TW201\*\*

WIRING DIAGRAM - 2632WD

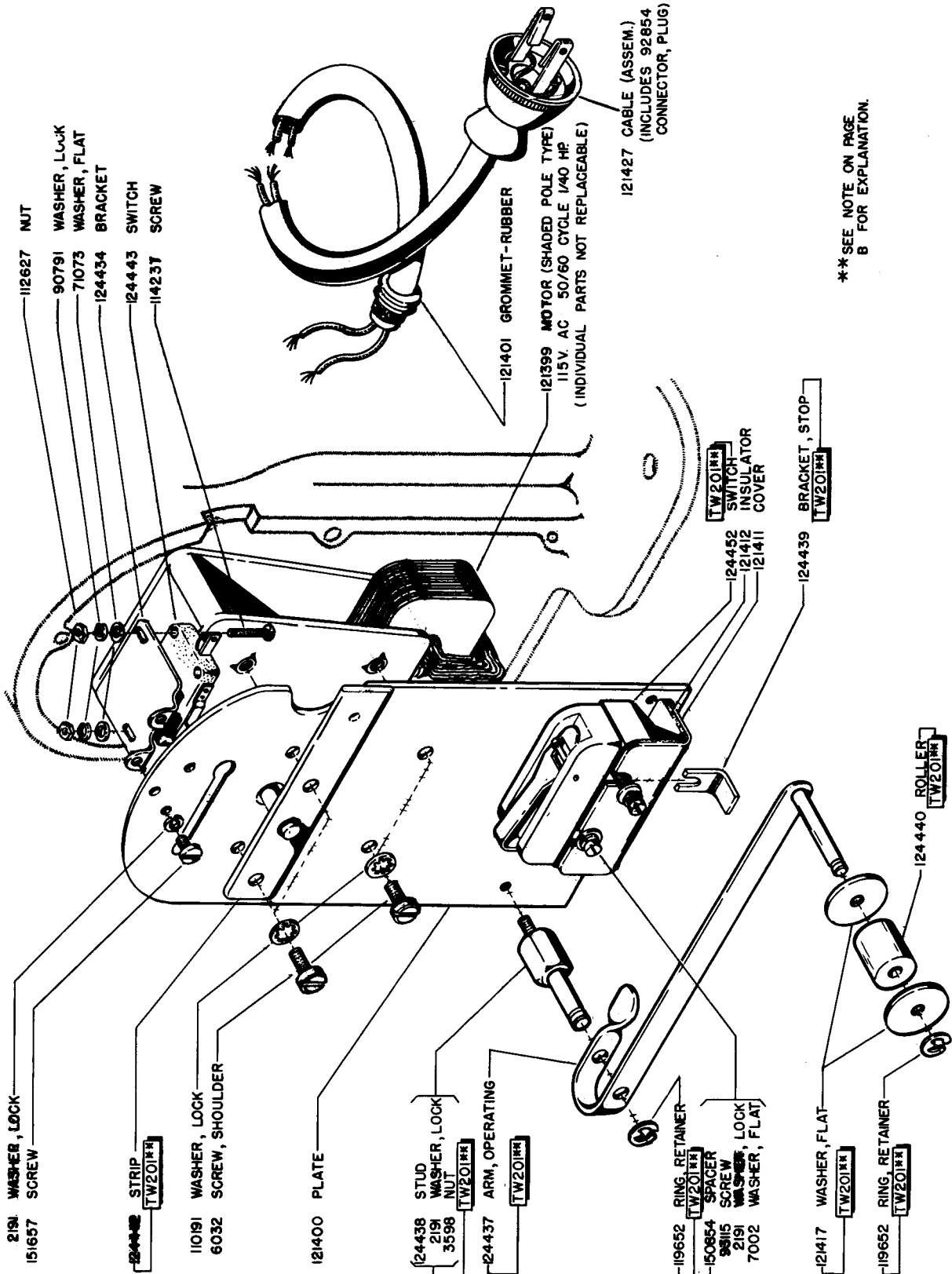

UNLESS OTHERWISE SPECIFIED  
ALL PARTS SHOWN ABOVE ARE COMMON TO  
TW200\*\* & TW201\*\*

\*\*SEE NOTE ON PAGE  
B FOR EXPLANATION.



1075B

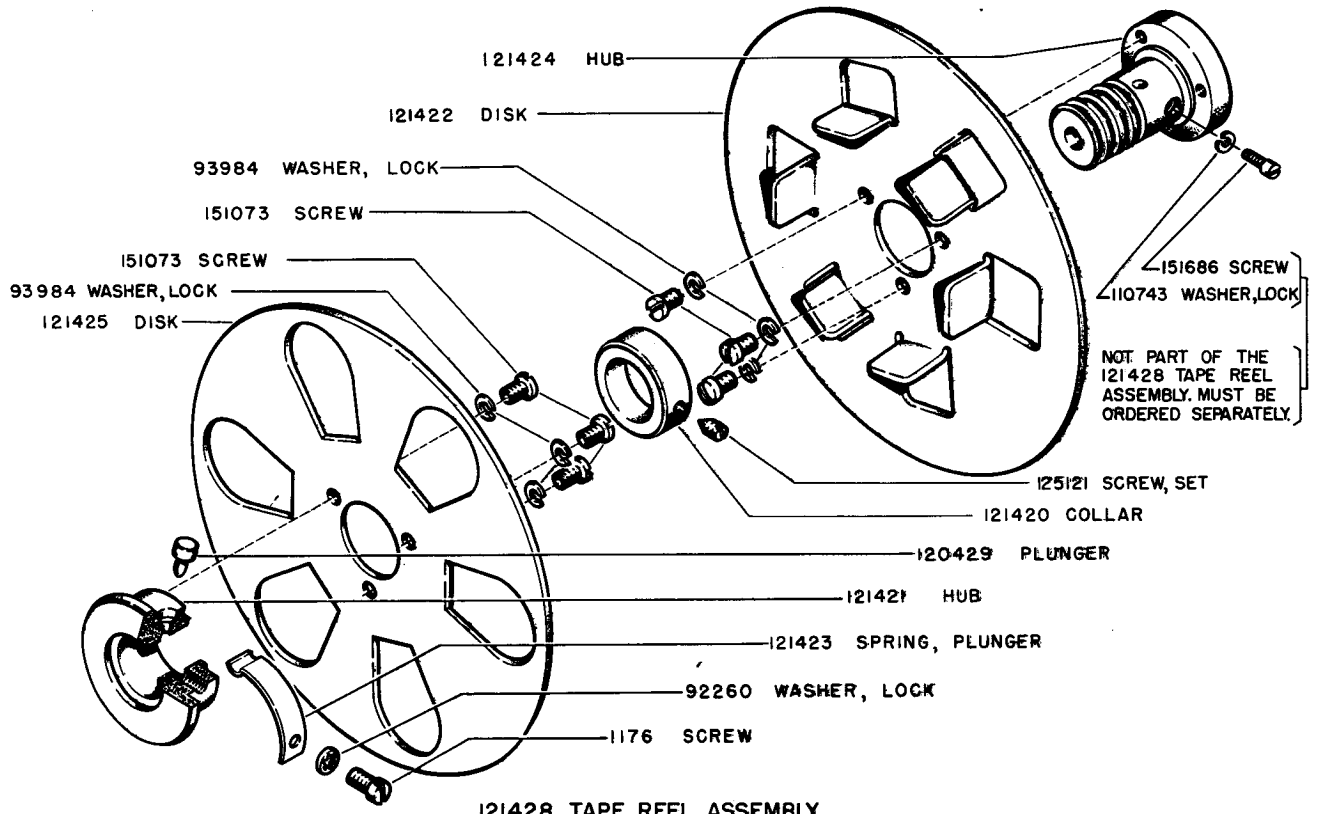

121428 TAPE REEL ASSEMBLY  
TW200\*\*

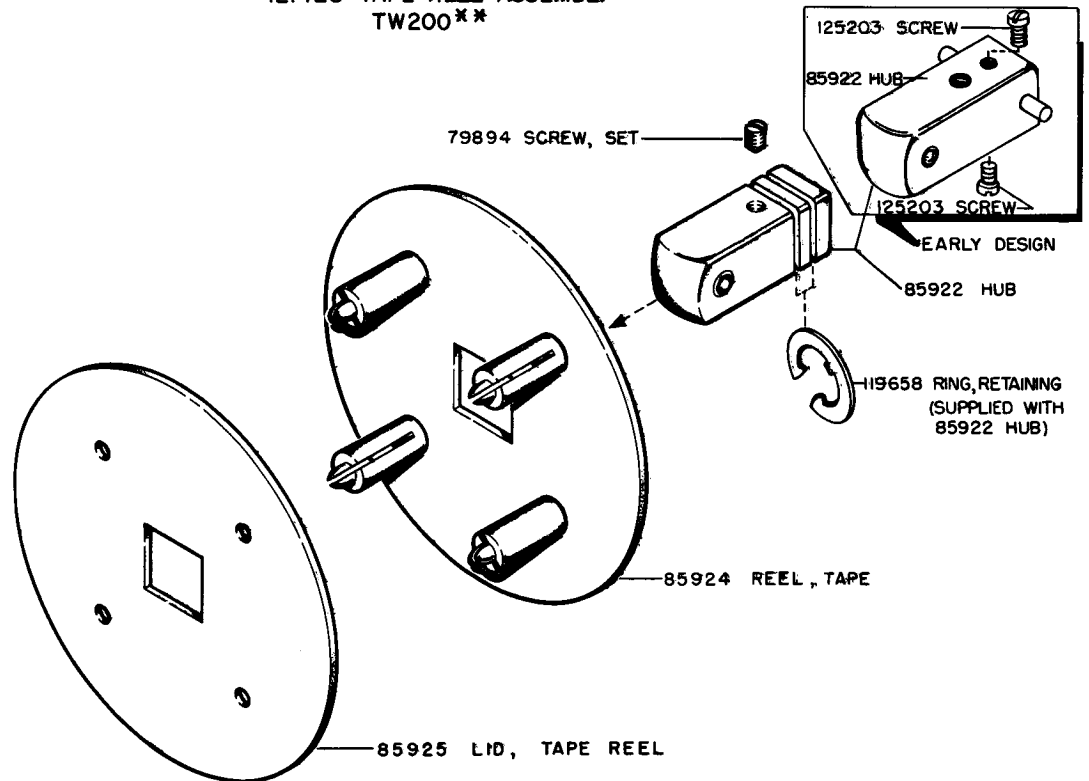

TAPE REEL ASSEMBLY  
TW201\*\*

\*\*SEE NOTE ON PAGE  
B FOR EXPLANATION.

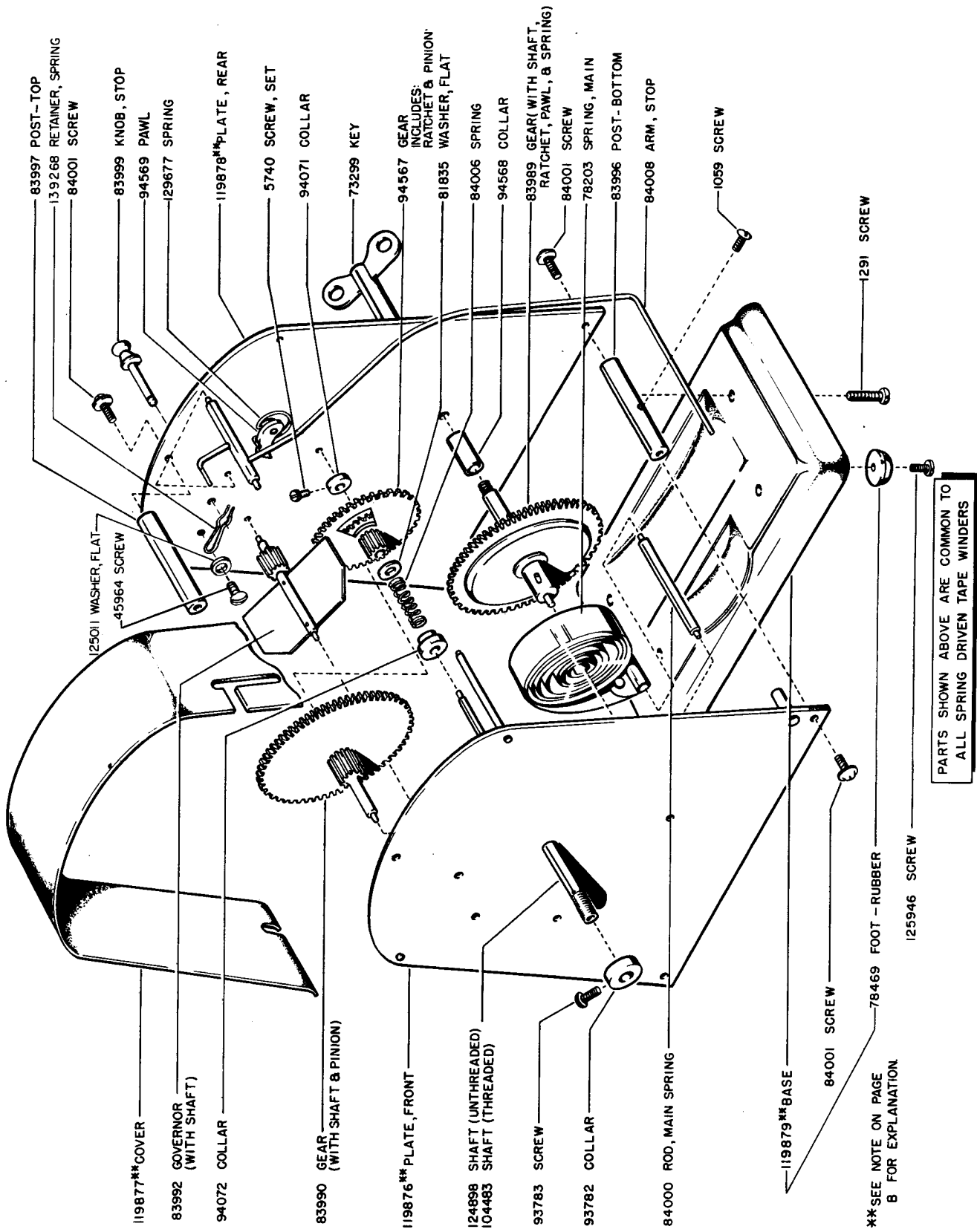

PARTS SHOWN ABOVE ARE COMMON TO ALL SPRING DRIVEN TAPE WINDERS

\*\*SEE NOTE ON PAGE B FOR EXPLANATION

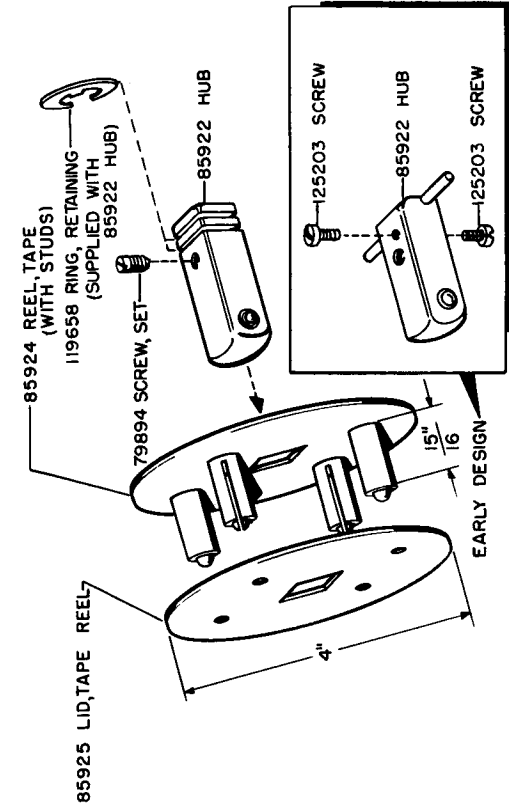

FIGURE 2

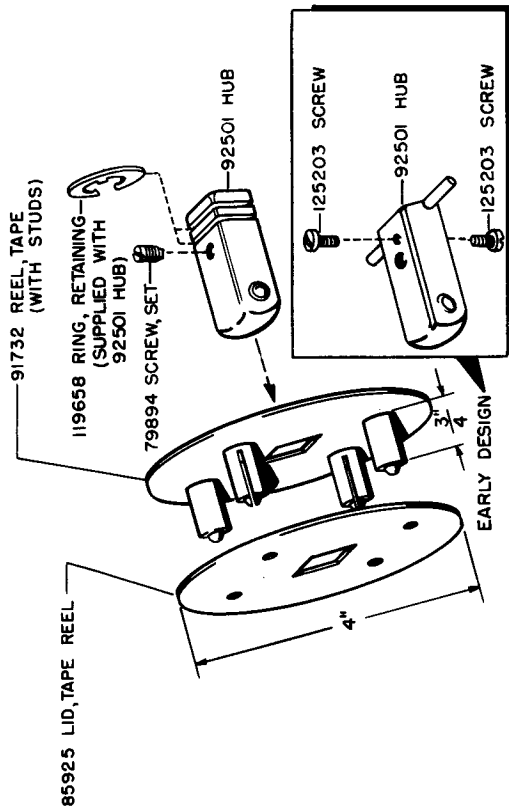

FIGURE 1

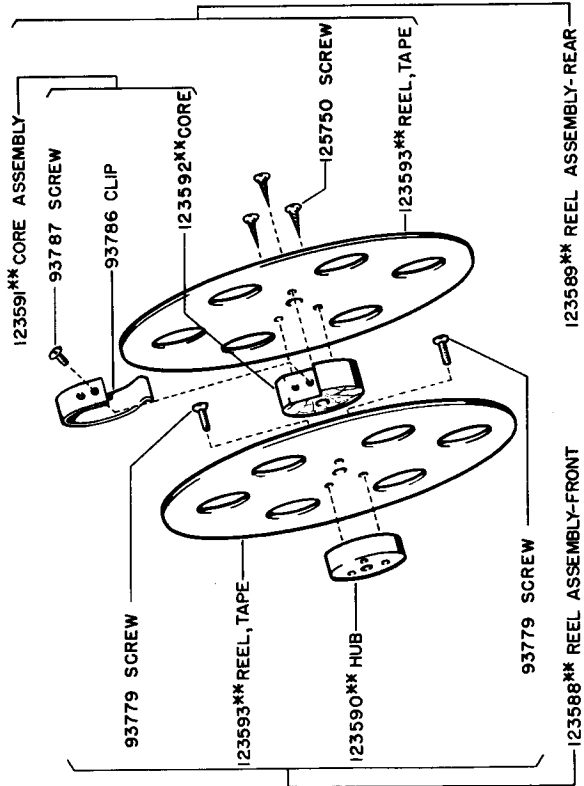

FIGURE 4

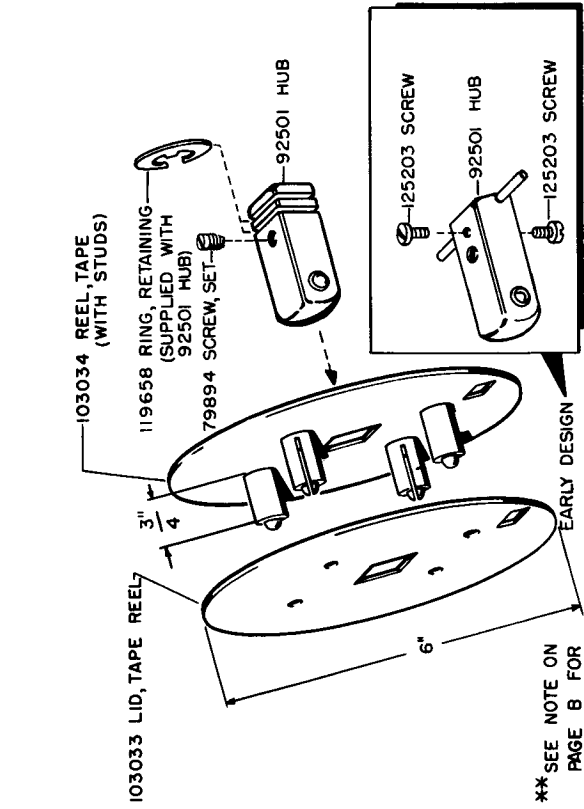

FIGURE 3

\*\* SEE NOTE ON PAGE B FOR EXPLANATION.

TAPE REELS FOR SPRING DRIVEN TAPE WINDERS

1075B

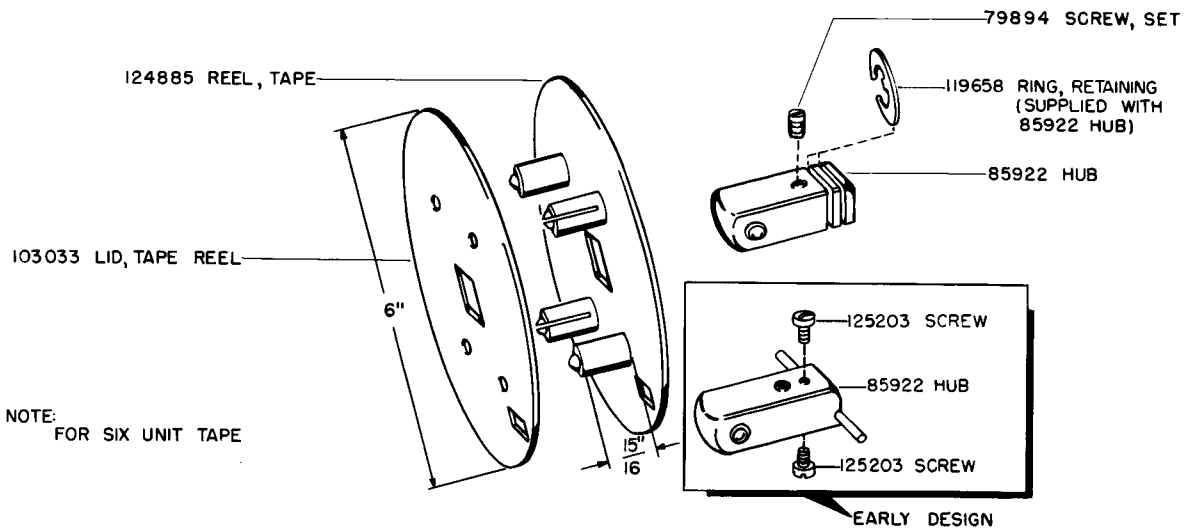
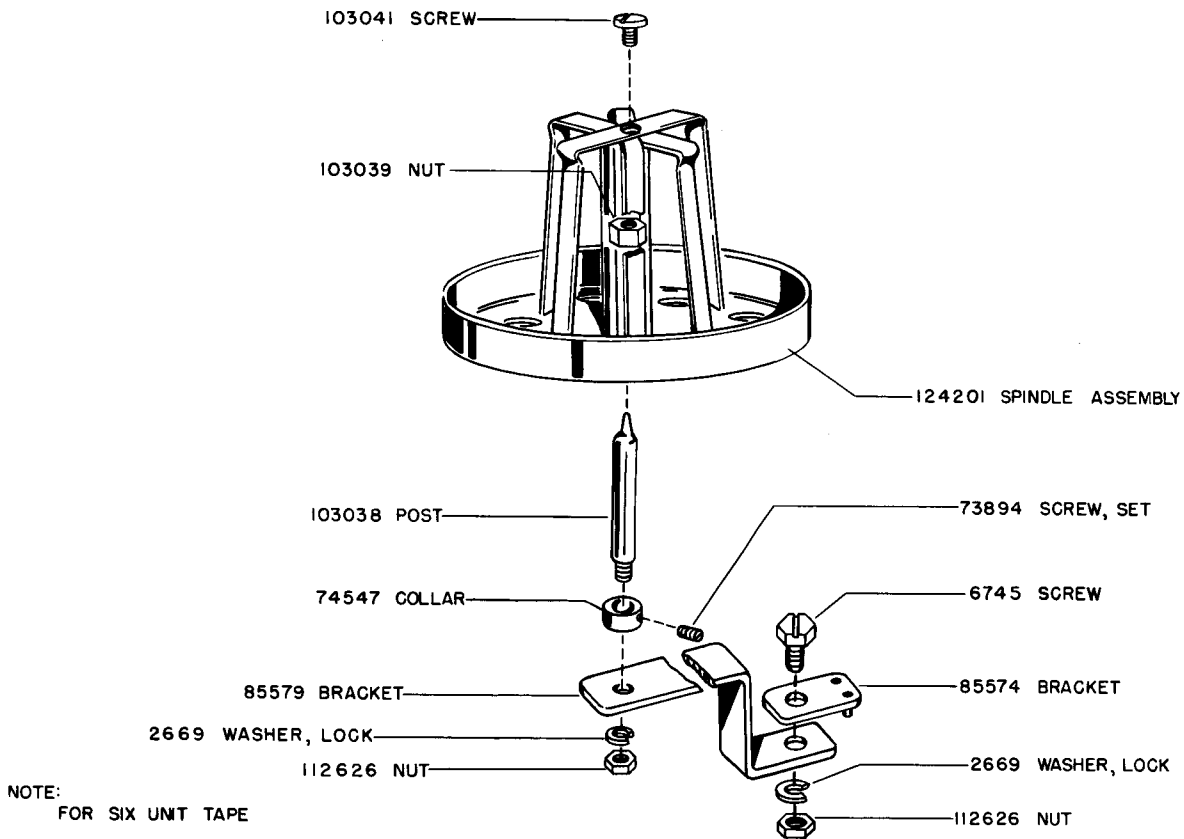
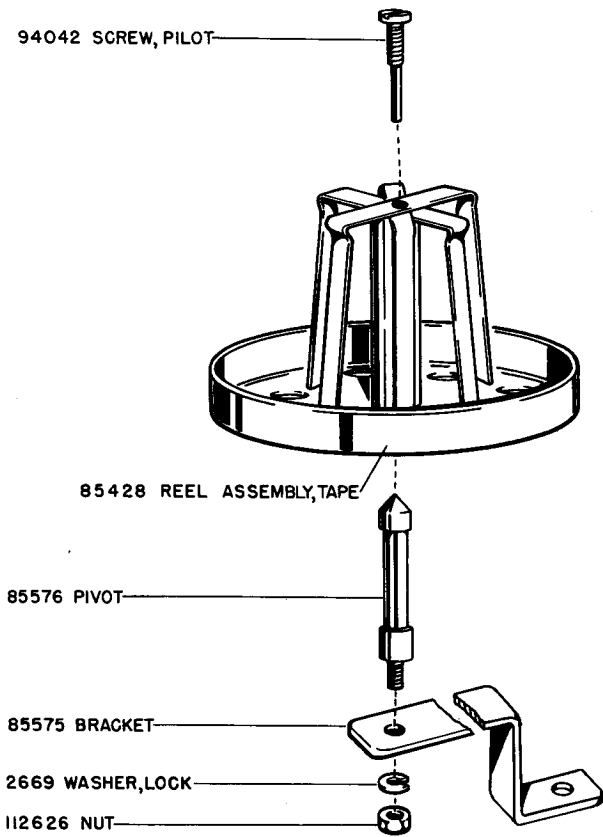

FIGURE 5



116836 SET OF PARTS FOR APPLYING CENTER UNWIND REEL  
(USED WITH SPRING DRIVEN TAPE WINDERS)  
(EXCLUDES PARTS IN FIGURE 5)



9189 SET OF PARTS FOR APPLYING CENTER UNWIND REEL  
(USED WITH SPRING DRIVEN TAPE WINDERS)

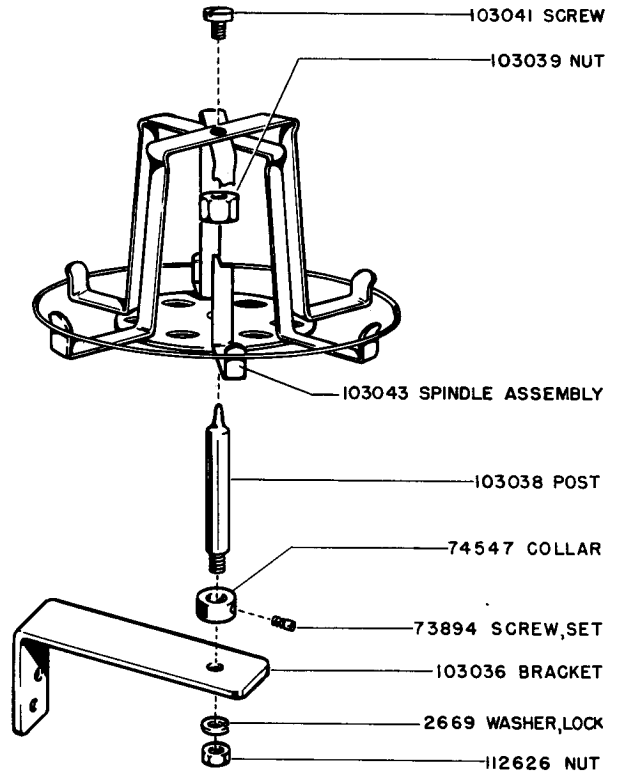

103035 SET OF PARTS FOR APPLYING CENTER UNWIND REEL  
(USED WITH SPRING DRIVEN TAPE WINDERS)

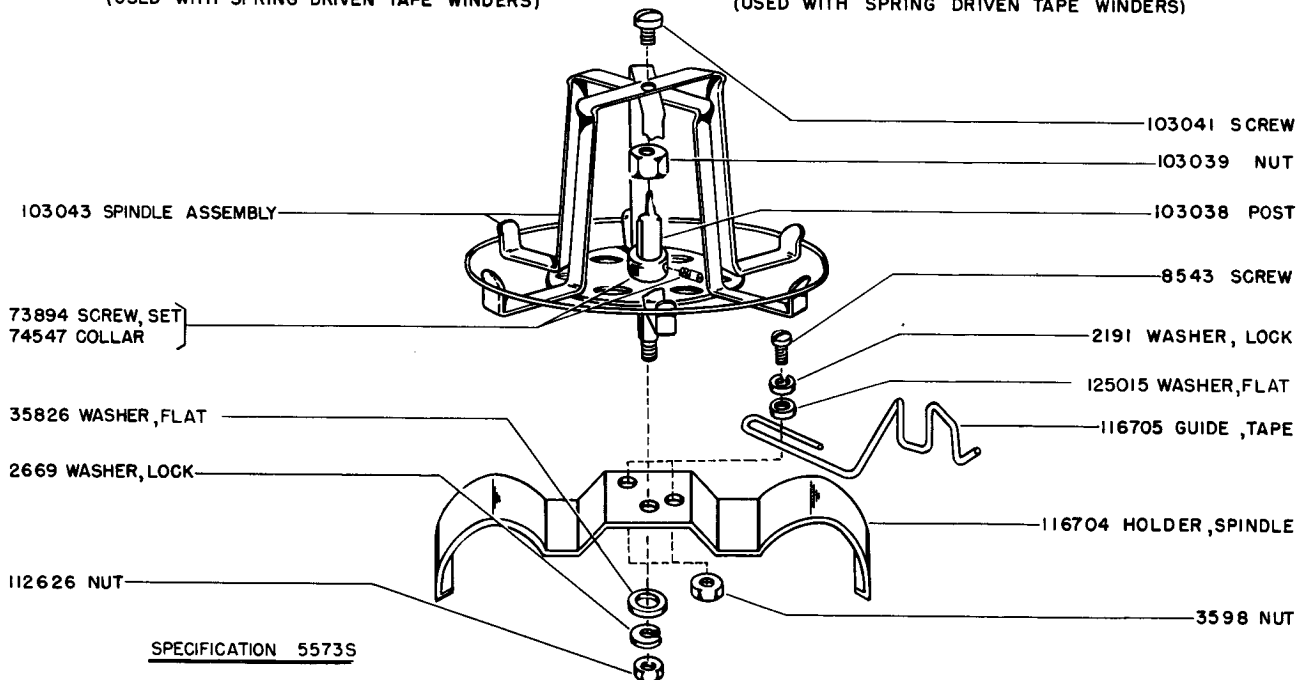

SPECIFICATION 5573S

114189 SET OF PARTS FOR APPLYING CENTER UNWIND REEL  
(USED ON A 14 TYPE TRANSMITTER DISTRIBUTOR COVER)

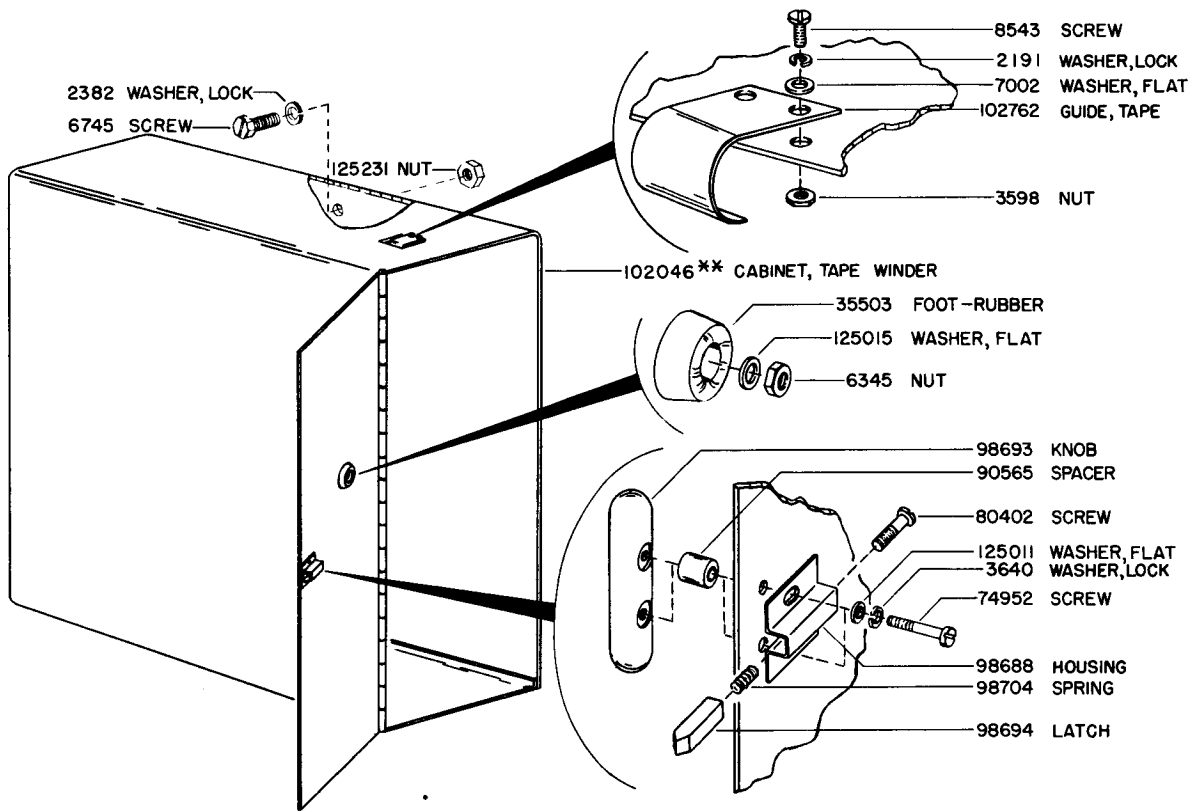

118634\*\* TAPE WINDER CABINET ASSEMBLY

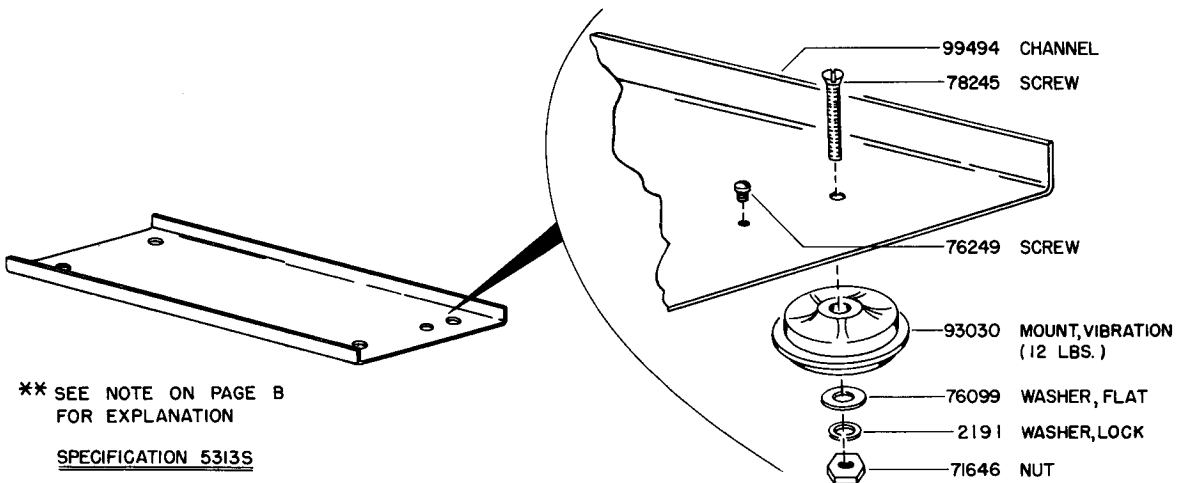

102492 TAPE WINDER MOUNTING CHANNEL ASSEMBLY

115725\*\* SET OF PARTS TO PROVIDE MEANS FOR MOUNTING A MOTOR  
DRIVEN SINGLE-REEL TAPE WINDER TO LEFT SIDE OF TABLE  
FOR ALL SINGLE-REEL TAPE WINDERS INCLUDING TW5 (BELL 2A)

\*\* SEE NOTE ON PAGE B  
FOR EXPLANATION

SPECIFICATION 5313S

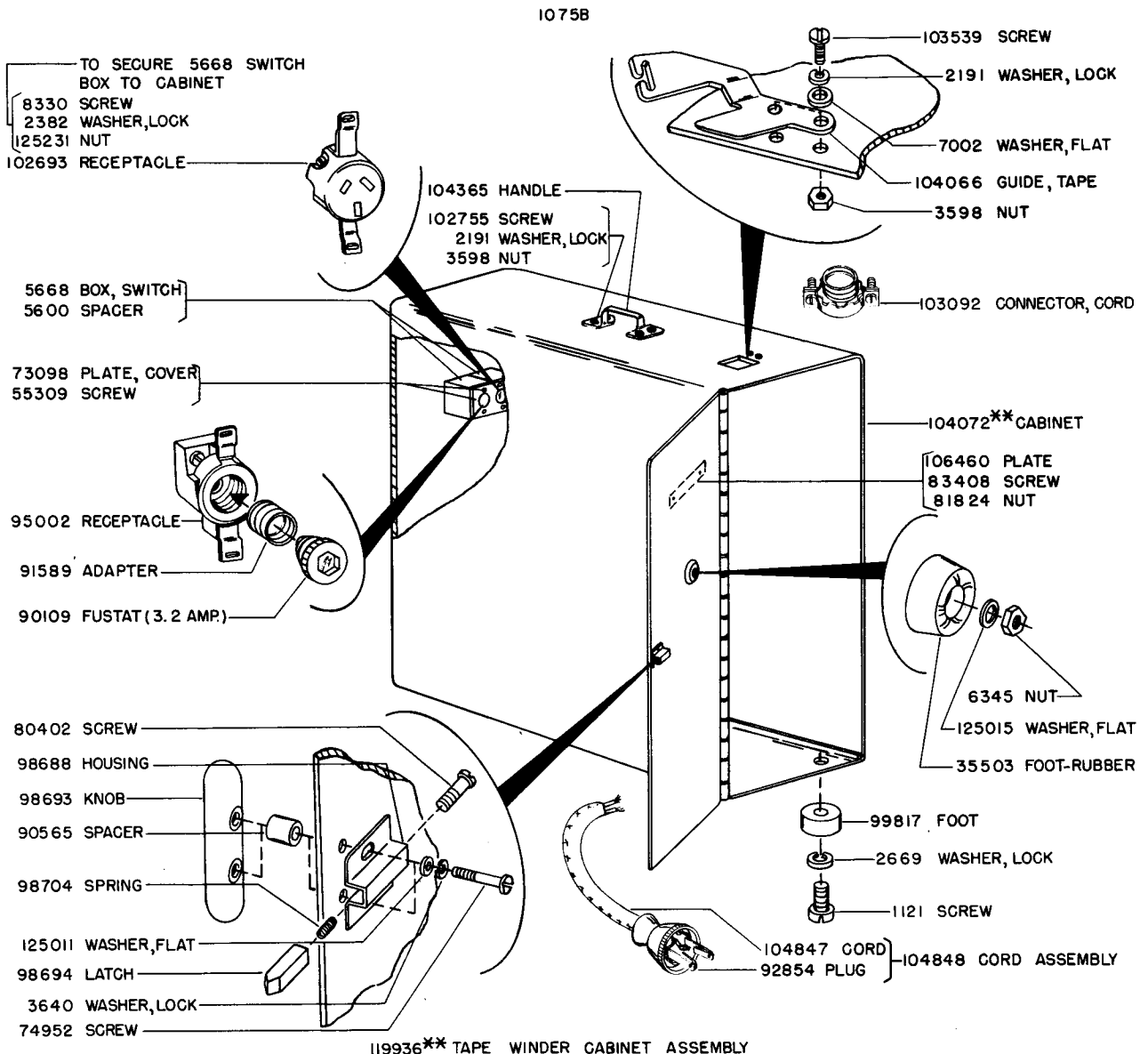

1075B  
119936\*\* TAPE WINDER CABINET ASSEMBLY

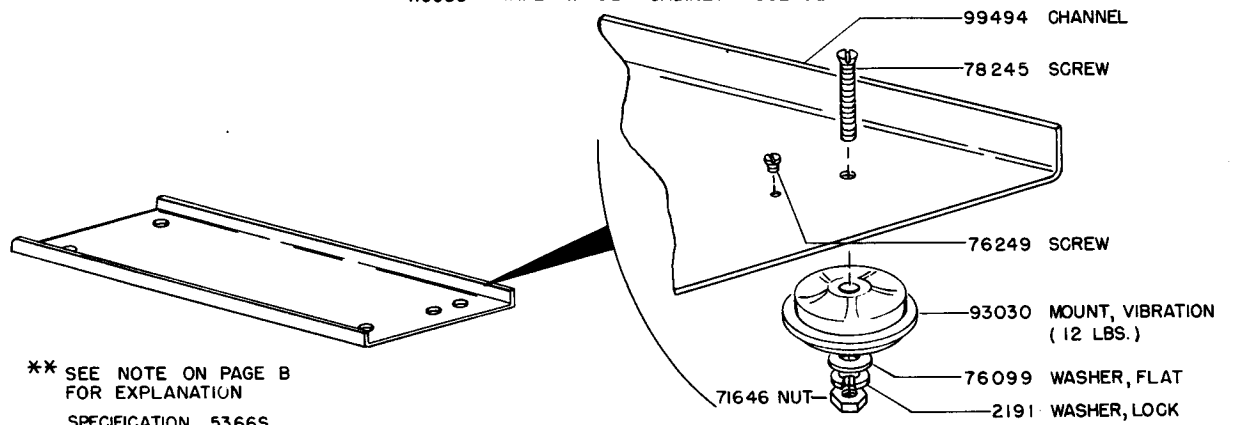

102492 TAPE WINDER MOUNTING CHANNEL ASSEMBLY

\*\* SEE NOTE ON PAGE B  
FOR EXPLANATION  
SPECIFICATION 5366S

115743\*\* SET OF PARTS TO PROVIDE MEANS FOR HOUSING A MOTOR  
DRIVEN SINGLE-REEL TAPE WINDER AT THE LEFT SIDE OF THE TABLE  
FOR ALL SINGLE-REEL TAPE WINDERS INCLUDING TW5 (BELL 2A)

## NUMERICAL INDEX

Part Number	Page Number and Description	Part Number	Page Number and Description
1026	Screw (6-40 x 3/8 Fil) 1, 2, 4, 6	71047	Shim (.010") 6
1043	Screw (10-32 x 5/16 Rd) 2, 3	71073	Washer, Flat 12
1059	Screw (6-32 x 7/32 Rd) 14	71646	Nut (6-32 Hex) 18, 19
1121	Screw (10-32 x 3/8 Fil) 1, 19	71659	Screw (6-40 Shoulder) 11
1160	Screw (6-40 x 5/16 Fil) 9	71971	Gear (35T) 2
1161	Screw (6-40 x 1/4 Fil) 1	71972	Pinion (5T) 6
1176	Screw (6-40 x 3/16 Fil) 2, 13	73098	Plate, Cover 19
1179	Screw (6-40 x 5/8 Fil) 6	93175	Washer, Lock 4, 5, 10
1181	Screw (6-40 x 1/4 Fil) 3	73299	Key 14
1187	Screw (10-32 x 1/4 Fil) 1, 2	73894	Screw (6-40 x 1/8 Set) 16, 17
1223	Screw (10-32 x 1/2 Fil) 1	74283	Washer, Spring 5, 10
1248	Screw (6-40 x 1/2 Flat) 7	74547	Collar 16, 17
1264	Screw (10-32 x 1/2 Flat) 10	74613	Screw (4-40 x 1/4 Hex) 11
1268	Screw (6-40 x 5/16 Flat) 1	74682	Screw (10-32 x 1-1/8 Flat) 4
1269	Screw (6-40 x 1/2 Fil) 2	74702	Spring 1
1286	Screw (10-32 x 7/16 Fil) 7	74952	Screw (4-40 x 5/8 Fil) 18, 19
1291	Screw (6-32 x 3/4 Flat) 14	75257	Post 1
2191	Washer, Lock Used Extensively	76086	Spring 4, 8
2199	Nut (7/16-32 Hex) 9	76099	Washer, Flat 18, 19
2382	Washer, Lock 18, 19	76249	Screw (6-40 x 1/8 Fil) 1, 18, 19
2449	Washer, Lock 10	76281	Terminal 6
2539	Nut (3/8-32 Hex) 4, 5, 10	76395	Disk, Friction 4, 8
2669	Washer, Lock Used Extensively	76396	Washer, Felt 4, 8
2836	Spring 11	76450	Shim (.028") 4, 8
3438	Washer, Flat 1, 2, 3, 4, 6, 7, 8, 9, 10	76484	Fan 6
3598	Nut (6-40 Hex) Used Extensively	77140	Nut (9/16-32 Hex) 2, 4, 8
3608	Spring 1	78203	Spring 14
3640	Washer, Lock 18, 19	78245	Screw (6-32 x 7/8 Flat) 18, 19
4814	Washer, Lock 4, 8	78301	Screw (10-32 x 5/8 Hex) 6
4851	Terminal 10	78369	Connector 6, 10
5446	Screw (6-40 x 9/16 Fil) 2, 9	78420	Collar 2
5600	Spacer 19	78454	Screw (10-32 x 7/16 Flat) 9
5668	Box, Switch 19	78469	Foot 14
5740	Screw (2-56 x 1/4 Fil) 14	79894	Screw (10-32 x 7/32 Set) 13, 15, 16
6032	Screw (8-32 x 7/16 Fil) 12	80402	Screw (4-40 x 15/32 Fil) 18, 19
6345	Nut (6-32 Hex) 18, 19	80444	Screw (6-40 x 1/4 Hex) 7
6745	Screw (10-32 x 1/2 Hex) 6, 16, 18	81824	Nut (4-40 Hex) 19
6810	Screw (10-32 x 3/8 Hex) 2, 3, 4	81835	Washer, Flat 14
6994	Bearing, Ball 4, 8	82283	Motor 6
7002	Washer, Flat Used Extensively	83408	Screw (4-40 x 3/16 Rd) 19
7481	Hub 2	83413	Buffer 1
7634	Spring 7	83989	Gear (80T) 14
8330	Washer, Flat 7, 19	83990	Gear (72T) 14
8333	Screw (10-32 x 3/8 Rd) 1	83992	Governor 14
8543	Screw (6-40 x 1/4 Fil) 17, 18	83996	Post 14
34432	Washer, Flat 2, 3, 10	83997	Post 14
35503	Foot 18, 19	83999	Knob 14
35551	Screw (10-32 x 3/8 Flat) 2, 10	84000	Rod 14
35826	Washer, Flat 17	84001	Screw (6-32 x 1/4 Washer Hd.) 14
41663	Washer, Flat 5, 10	84006	Spring 14
41974	Spring 7	84008	Arm 14
45964	Screw (4-36 x 3/16 Rd) 14	85428	Reel Assembly 17
45969	Screw (10-32 x 3/4 Flat) 1, 5	85574	Bracket 16
55010	Screw (10-32 Shoulder) 1, 7	85575	Bracket 17
55309	Screw (6-32 x 1/2 Oval) 19	85576	Pivot 17
70497	Nut (5/16-32 Hex) 4, 8	85579	Bracket 16



## NUMERICAL INDEX

Part Number	Page Number and Description	Part Number	Page Number and Description
85832	Winder, Tape B	98221	Bracket 2, 3
85922	Hub 13, 15, 16	98222	Shaft, Clutch 8
85924	Reel 13, 15	98224	Block, Bearing 1
85925	Lid 13, 15	98225	Arm 1
85931	Post 7	98227	Hub 2
85935	Post 7	98228	Bearing 2
89437	Cord, Assembly 6	98229	Washer - Felt 2
90109	Fustat (3.2 Amp) 19	98231	Shaft 2
90480	Nut, Capstan 4, 8	98232	Plate - Outer 1
90490	Shim (.005") 9	98233	Plate - Inner 1
90565	Spacer 18, 19	98234	Bracket, Bearing 2
90790	Washer, Flat 9	98235	Plate, Bearing 4, 8
90791	Washer, Lock 12	98236	Lever 1
91280	Terminal 6, 11	98237	Pin 1, 7
91589	Adapter 19	98238	Bracket 1
91683	Nut (15/32-32 Hex) 9	98239	Guide 1
91684	Nut (15/32-32 Ring) 9	98240	Guard 1
91729	Winder, Tape B	98241	Post 1, 4
91732	Reel, Tape 15	98242	Post 1
91819	Set of Parts B, 17	98421	Pin 1
92260	Washer, Lock 13	98423	Plate 2
92501	Hub 15	98688	Housing 18, 19
92854	Connector 12, 19	98693	Knob 18, 19
93030	Mount, Vibration 18, 19	98694	Latch 18, 19
93115	Screw (6-40 x 1-1/4 Fil) 11, 12	98704	Spring 18, 19
93779	Screw (4-36 x 1/4 Flat) 15	99082	Screw (6-32 x 11/16 Hex) 10
93782	Collar 14	99381	Foot 11
93783	Screw (4-36 x 1/4 Fil) 14	99494	Channel 18, 19
93786	Clip 15	99496	Plate, Base 1
93787	Screw, Wood (3/16" long)	99497	Plate - Inner 1
93791	Winder, Tape B	99498	Shaft 2
93984	Washer, Lock 13	99499	Bracket, Bearing 2
94042	Screw (6-40 Pilot) 17	99712	Screw (10-32 x 5/16 Hex) 7, 8, 9
94071	Collar 14	99817	Foot 19
94072	Collar 14	101965	Connector 6
94567	Gear (60T) 14	102017	Washer, Beveled 4, 5, 10
94568	Collar 14	102046**	Cabinet 18
94569	Pawl 14	102073	Reel Assembly 5
94665	Screw (6-40 Shoulder) 11	102212	Plate, Bearing-Inner 1, 7
95002	Receptacle 19	102213	Plate, Bearing-Outer 1, 7
98200	Reel Assembly 5	102214	Screw (6-40 x 13/64 Flat) 1, 7
98201	Hub 5	102345	Hub 4, 5, 10
98202	Shaft 5	102346	Shaft 4, 5, 10
98203	Gear (144T) 4, 5, 10	102492	Channel Assembly 18, 19
98204	Flange 4, 5	102495	Cord Assembly 6
98205	Reel 4, 5	102693	Receptacle 19
98206	Core 5	102755	Screw (6-40 x 7/16 Flat) 19
98207	Knob 4, 5	102762	Guide 18
98208	Core 5	102898	Connector 6
98209	Pinion (10T) 8	102899	Cord Assembly 6
98210	Gear (108T) 2, 9	103032	Winder, Tape B
98212	Post 1	103033	Lid 15, 16
98213	Pad 1	103034	Reel 15
98214	Channel 1	103035	Set of Parts B, 17
98215	Plate, Base 1	103036	Bracket 17
98216	Support 1	103038	Post 16, 17
98217	Stud 1	103039	Nut (6-40 Special) 16, 17

## NUMERICAL INDEX

Part Number	Page Number and Description	Part Number	Page Number and Description
103041	Screw (6-40 x 1/4 Fil) 16, 17	120175	Plate, Designation 9
103043	Spindle Assembly 17	120429	Plunger 13
103092	Connector, Cord 19	121245	Clamp, Cable 1, 2
103539	Screw (6-40 x 3/8 Fil) 19	121332	Arm, Tape - Left 1
104066	Guide 19	121333	Arm, Tape - Right 1
104072**	Cabinet 19	121398**	Housing 11
104302	Pin 10	121399	Motor 12
104365	Handle 19	121400	Plate 12
104478	Winder, Tape B	121401	Grommet 12
104483	Shaft 14	121402	Grommet 11
104847	Cord 19	121403	Strip 11
104848	Cord Assembly 19	121404	Wedge 11
105866	Clamp, Cable 9	121406	Lever 11
106460	Plate 19	121407	Shaft 11
108353	Screw (6-40 x 1/2 Fil) 11	121408	Roller 11
110191	Washer, Lock 12	121409	Washer - Fiber 11
110711	Spacer 4	121410	Screw (10-32 Shoulder) 11
110712	Core 4	121411	Cover 11, 12
110713	Core 4	121412	Insulator 11, 12
110715	Reel Assembly 4	121413	Spacer 11
110743	Washer, Lock 11, 13	121414	Stud 11
110822	Screw (10-32 x 13/16 Flat) 4	121415	Arm 11
110823	Screw (10-32 x 11/16 Flat) 4	121416	Roller 11
111666	Plate, Base 1	121417	Washer, Flat 12
111667	Plate - Inner 1	121418	Screw (6-40 Shoulder) 11
111669	Coupling, Driven 3	121420	Collar 13
111671	Shaft 3	121421	Hub 13
111672	Bracket, Bearing 3	121422	Disk 13
111673	Shaft 3	121423	Spring 13
111674	Coupling, Driving 3	121424	Hub 13
111675	Bracket 3	121425	Disk 13
112080	Washer, Flat 11	121426	Strap 11
112626	Nut (10-32 Hex) 1, 2, 7, 9, 10, 11, 16, 17	121427	Cable 12
112627	Nut (2-56 Hex) 12	121428	Reel Assembly 13
114189	Set of Parts B, 17	122829	Spring 11
114237	Screw (2-56 x 1/2 Fil) 12	122960	Post 11
114499	Cam, Stop 4, 8	123587**	Winder, Tape B
114501	Gear 4, 8	123588**	Reel Assembly 15
115725**	Set of Parts 18	123589**	Reel Assembly 15
115739**	Winder, Tape B	123590**	Hub 15
115743**	Set of Parts B, 19	123591**	Core Assembly 15
115753**	Winder, Tape B	123592**	Core 15
115754**	Winder, Tape B	123593**	Reel 15
116704	Holder, Spindle 17	123699	Screw (5-10 Shoulder) 5, 10
116705	Guide, Tape 17	123700	Plate, Locking 5, 10
116836	Set of Parts B, 16	123701	Guard 4, 8
118734	Switch, Toggle 9	123702	Guard, Gear - Left 2, 7
118834	Cabinet Assembly 18	123703	Guard, Gear - Right 2
119652	Ring, Retaining 11, 12	123704	Plate - Outer 1
119653	Ring, Retaining 10	123705	Plate - Inner 1
119658	Ring, Retaining 13, 15, 16	123706	Screw (10-32 x 1/4 Flat) 2, 3
119876**	Plate - Front 14	124201	Spindle Assembly 16
119877**	Cover 14	124434	Bracket 12
119878**	Plate - Rear 14	124435	Arm 11
119879**	Base 14	124437	Arm 12
119936**	Cabinet Assembly 19	124438	Stud 12
		124439	Bracket, Stop 12

## NUMERICAL INDEX

Part Number	Page Number and Description	Part Number	Page Number and Description
124440	Roller 12	129676	Washer, Clamp 7
124441	Pulley, Brake 11	129677	Spring 14
124442	Strip 12	135378	Pinion (10T) 4
124443	Switch 12	135379	Shaft, Clutch 4
124451	Switch 11	139092	Plate, Base 7
124452	Switch 12	139094	Cable 10
124884**	Winder, Tape B	139159	Connector 10
124885	Reel 16	139190	Arm 7
124890	Spacer 2, 3	139268	Spring 14
124898	Shaft 14	150854	Spacer 12
125006	Screw (10-32 x 5/8 Flat) 5, 10	150990	Washer - Felt 9
125011	Washer, Flat 14, 18, 19	150991	Washer - Felt 9
125015	Washer, Flat 8, 17, 18, 19	151073	Screw (4-40 x 5/32 Fil) 13
125120	Screw (6-40 Shoulder) 1, 7	151405	Bushing 11
125121	Screw (6-40 Special) 13	151606	Screw (10-32 x 1/4 Hex) 7
125170	Screw (8-32 x 5/16 Fil) 11	151631	Screw (6-40 x 5/16 Hex) 9
125171	Screw (10-32 x 1/2 Flat) 2	151657	Screw (6-40 x 1/4 Fil) 9, 11, 12
125185	Screw (10-32 x 1/4 Rd) 2	151659	Screw (6-40 x 1/4 Fil) 4, 5, 7, 9, 10
125203	Screw (4-40 x 5/32 Fil) 13, 15, 16	151686	Screw (4-40 x 3/8 Fil) 13
125218	Nut (1/4-32 Hex) 10	151692	Screw (6-40 x 3/16 Fil) 7, 8
125231	Nut (10-32 Hex) 18, 19	151723	Screw (10-32 x 3/8 Hex) 9
125245	Spring 10	151724	Screw (10-32 x 5/8 Hex) 10
125750	Screw, Wood (1/2" long) 15	159222	Reel Assembly 10
125946	Screw (4-36 x 3/8 Flat) 14	159227	Core 10
126899	Plate, Base 7	159228	Core 10
126900	Bracket, Motor 10	160471	Shaft 10
126901	Plate - Inner 7	160472	Hub 10
126902	Plate - Outer 7	160473	Block 10
126903	Bracket 9		
126904	Bracket 9		
126905	Bearing 9		
126907	Shaft Assembly 9		
126908	Gear, Driven (40T) 9		
126909	Pinion (7T) 10		
126910	Hub 9		
126911	Stud 7		
126912	Lever 7		
126913	Bracket 7		
126914	Guide 7		
126915	Block 7		
126916	Arm 7		
126917	Block, Mounting 7		
126918	Disk 10		
126919	Bracket 9		
126920	Spring 10		
126921	Core 10		
126922	Core 10		
126923	Flange 10		
126924	Knob 10		
126987	Motor 10		
126988	Arm 7		
126989	Bracket 7		
126990	Cable 10		
126992	Reel Assembly 10		
129082	Plate, Directional 7		
129425	Spring 11		
129675	Guide 7		

