

QUESTION #1. Give a brief explanation of the electron theory of current flow.

ANSWER #1. When a battery is connected into a circuit and a current flows through the circuit, it is ordinarily said that the current flows from the positive terminal of the battery through the circuit to the negative terminal. The early experimenters in electricity assumed that the current was a flow of positive electricity from the positive terminal of the battery through the circuit to the negative terminal. It is now believed that the current is a flow of negative charges of electricity in the opposite direction around the circuit. More exactly, the flow of current consists in the motion of extremely small charges of negative electricity, called electrons, and the action of the battery voltage is to drive these electrons around the circuit. Electrons are present in very great numbers in all metals and ordinarily move around inside the metal in a haphazard manner, bumping into the atoms of the metal. When the battery voltage is applied, the electrons are forced to take up a general motion around the circuit in addition to their haphazard motion. This drift of electrons around the circuit constitutes the current flow.

QUESTION #2. Show by sketch and explain electron emission from a heated metal. (Filament).

ANSWER #2. When a metal, such as tungsten, is heated to a high temperature in an extremely high vacuum, electrons are emitted from its surface. Each electron is emitted with what is called an initial velocity, which is dependent upon the temperature of the heated metal. It should be noted that the emission of electrons is an effect caused by the temperature of the metal and not by the current that is passed through the metal to heat it. The emitted electrons do not all have the same initial velocity. Some electrons acquire just enough velocity to break through the surface others are able to travel a slightly greater distance and only one in a billion perhaps can travel any considerable distance from the surface. The average velocity of the emitted electrons is very high - many miles per second - but the effect is almost negligible on account of the very high charge associated with the very small mass of each electron. The number of electrons emitted from a given filament in a high vacuum depends greatly upon the nature of the filament material, the condition of its surface and upon its temperature. The effect of the electron emission from the metal is as follows: Each electron emitted from the filament renders the filament more positive. The positive charge on the filament is equal and opposite to the sum of the charges on the emitted electrons so that no matter to what distance any given electron may travel it will finally be pulled back into the filament. Accompanying diagram shows a straight filament made of tungsten in a highly evacuated glass container. Suppose

ANSWER #2. Continued.

that this filament is brought to a high temperature. The emitted electrons will travel to varying distances from the filament. The small dots in the diagram represent the electrons. The great majority of electrons form a dense cloud just above the surface of the filament. This cloud is practically stationary as a whole, but is being constantly renewed by electrons flying out from the filament to take the place of those that fall back into it. The cloud becomes less and less dense the greater the distance from the filament, because only a very few electrons are emitted with an initial velocity sufficient to carry them to the glass wall of the container. To sum up: The purpose of the heated filament is to render available great numbers of electrons by keeping them in a free condition in its immediate vicinity.

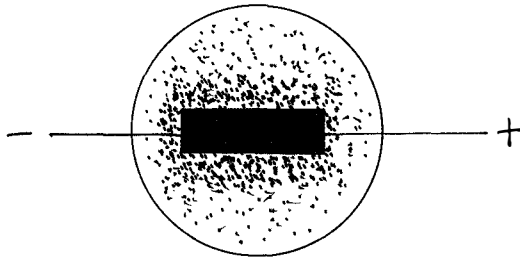

QUESTION #3. Explain how filaments are constructed; metals most extensively used in their construction; and make of tube in which each are used.

ANSWER #3. The General Electric tubes have filament of thoriated tungsten. As the filament is drawn out into a fine thread the thorium is added, together with a small percentage of carbon. About 1% of thorium is added. Thorium is one of the basic metals. It is easy to recognize a tube, the filament of which has a small amount of thorium added to the tungsten. A tungsten filament glows with a brilliant dazzle, while the thoriated tungsten glows with a dull yellow color.

The Western Electric tubes have platinum-nickel filament supports, upon which are pasted oxides of strontium or barium. Up until recently the WE tubes emitted less electrons than the GE on account of filament construction but the latest information states that their tubes will emit more electrons with less current than the GE, which makes it the more efficient tube.

QUESTION #4. Give advantages and disadvantages of each.

ANSWER #4. The GE tubes have the advantage that they may be rejuvenated and the disadvantage that they require more current to operate, while the WE tubes have the advantage of using less current but the disadvantage non-rejuvenation.

QUESTION #5. Name two metals used in the construction of plates.

ANSWER #5. Tungsten is used in the construction of plates because of the great amount of heat it will dissipate and because of its high fusing point, which is 3870° Centigrade. Altho most commercial tubes use molybdenum in plate construction, even tho it has a lower fusing point of 1450° Centigrade, on account of its mechanical perfection.

QUESTION #6. Draw a simple circuit used for half wave and full wave rectification. Explain each.

ANSWER #6.

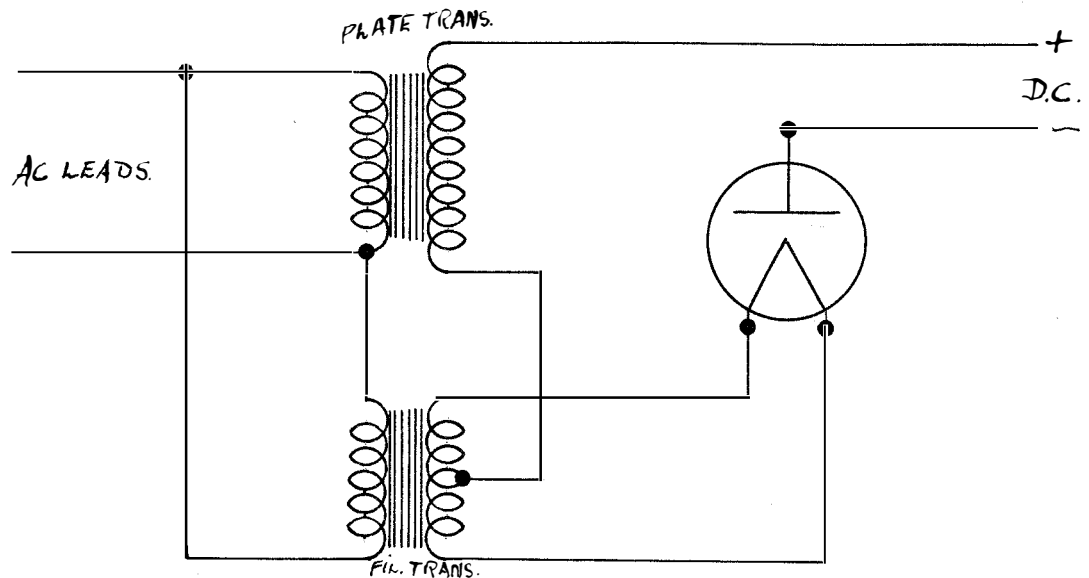

Because, in a vacuum tube, electrons are emitted from the hot filament only, vacuum tubes are widely used as rectifiers. In the accompanying diagram, the filament is heated by an alternating current supplied by the alternator. The filament is thus alternately positively and negatively charged. When it is negatively charged it will throw off electrons. At this instant the cold plate will be positive and will attract these negative electrons which will flow through the space in the tube to the cold plate through any appliance which may be placed in the circuit and then back to the generator and the hot filament. But at the next instant, usually 1/120 of a second later, the hot filament is charged positively and the cold plate at this instant is negative. But the plate being cold emits no electrons so no current passes from the plate to the filament even though the voltage between them is in the proper direction to cause electrons to flow from the cold plate to the hot filament if any electrons were emitted from the cold plate. Thus an alternating current is taken from the generator and a direct current delivered to the appliance. But this direct current, is only in impulses in one direction. It as tho one half of the alternating current cycle were chopped off, allowing the positive half to flow in the external circuit. In the diagram on the next sheet using two tubes, one tube takes the first half of the cycle and the second tube take the second half of the cycle creating an effect of reversing the direction of the second half of the cycle thus making both halves of the cycle flow in the same direction. This is called full wave rectification.

ANSWER #6. Continued.

Diagram of full-wave rectification.

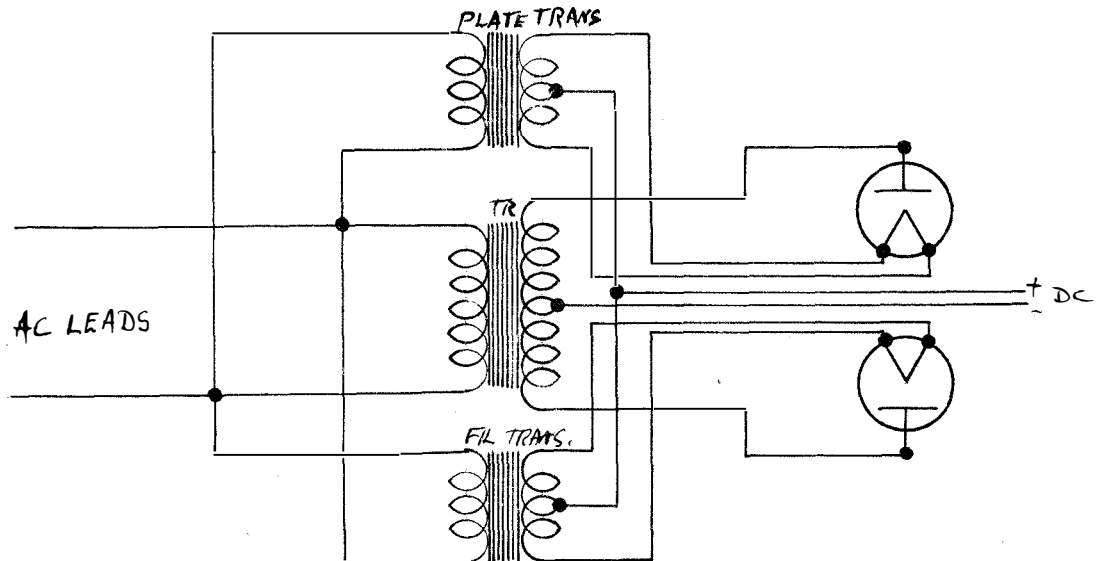

QUESTION #7. Explain how tubes are evacuated and the effect of gas left in them.

ANSWER #7. Tubes are evacuated as much as possible just prior to sealing them, by applying a suction pump which pumps out all of the air that it possibly can. Incorporated in the construction of the tube is a small piece of metal called a getter which acts like a sponge and absorbs any gas left in the tube by the suction pump. Vacuum tubes which employ a high plate voltage must be as nearly evacuated of gas as is possible, because the speed of the electrons would be so great that collision with the atoms of gas would produce heat that would burn the filament. Soft tubes, or tubes in which some gas is left are sometimes used where a low plate voltage is used, because the atoms of gas actually help the flow of electron flow, but the disadvantage is the heat created which gives the filament a shorter life.

QUESTION #8. Explain the function of the third electrode (Grid).

ANSWER #8. In a three electrode vacuum tube there is an additional electrode called the grid which is interposed between the plate and the filament. As its name indicates the grid is ordinarily in the form of a mesh or network of wires through which the stream of electrons flows to the plate. The grid acts as a sort of screen around the filament and prevents the full force of the positive plate voltage from being exerted upon the electrons which are being emitted from the filament. If the grid is connected to the filament so as to bring it to the same potential it will itself exert no force and hence the total force at the filament will be less under these circumstances than if the grid were removed. It was shown before in the case of the two electrode vacuum tubes that when the electron flow to the plate is less than that corresponding to the total emission from the filament the current to the plate depends upon the electric force which is acting near the filament; that is; the current is limited by space charge. Under these condi-

ANSWER #8. Continued.

tions, the presence of the grid will, when it is at filament potential result in a lower value of the plate current than would flow if the grid were absent. Suppose now that a battery usually called the C Battery is inserted in the lead connecting the filament and grid, by means of which the grid can be made positive or negative with respect to the filament by any desired voltage. If the grid is made somewhat positive, it will itself exert an attractive force upon the electrons near the filament and a greater number will leave the filament and start across the tube. In fact, the current flow will increase until the space charge effect neutralizes not only the force of the plate but also that of the grid. Very nearly all of the electron current will flow through the spaces between the grid wires and go to the plate so that as a result of a positive voltage on the grid, the plate current will increase. A negative voltage on the grid will produce the opposite effect, for then the force exerted by the grid will oppose that of the plate and the plate current will be reduced. In fact, the grid voltage can readily be made negative enough to stop completely the current flow through the tube. It is evident therefore that the grid acts as a control over the current flow to the plate in that, by variation of the voltage of the grid, the current to the plate can be increased or decreased at will. The electrons pass through the grid to the plate and unless the grid voltage is made quite positive, very few hit the grid wires. The current to the grid is, therefore, practically zero and only a feeble current flows from the C battery; so that very little power is required to regulate the voltage of the grid.

QUESTION #9. What is meant by space charge and what is its effect?

ANSWER #9. All of the emitted electrons do not flow over to the plate excepting when the plate voltage becomes high. The electron flow to the plate starts because the plate is positive and attracts the electrons away from the immediate vicinity of the filament. When the current is flowing, however, there will be electrons which are in motion over to the plate and which will, after a fashion, fill up the space between filament and plate. These electrons are negatively charged and therefore tend to repel those electrons which are about to start over to the plate. Thus the force exerted by the electrons in the space between the filament and plate tends to neutralize the force exerted by the plate. In fact, there will be an imaginary surface surrounding the filament at a certain distance away and at this surface the force of the plate will be completely neutralized. The force in the region between this imaginary surface and the surface of the filament will be such as to draw the emitted electrons back to the filament, while on the other side of the surface the force will be such as to pull the electrons over toward the plate. Any electrons which are emitted with sufficient velocity to overcome the opposing force exerted in the region near the filament, and hence to pass the imaginary surface, will flow over to the plate under the influence of the aiding force on the other side.

ANSWER #9. Continued.

Those electrons which have not sufficient velocity to reach the surface of zero force will be pulled back into the filament again. Thus the location of this imaginary surface of zero force determines the percentage of the electrons which flow over to the plate. The nearer the surface lies to the surface of the filament, the greater the number of electrons which can get by and hence the greater will be the plate current. The location of this surface depends upon the plate voltage and the number of electrons which are in motion to the plate or the space charge. An increase in the plate voltage tends to move the surface of zero force nearer the filament, while an increase in the plate current has the effect of moving the surface away from the filament. When the voltage of the plate is negative with respect to the filament the surface coincides with the glass wall of the tube; as the voltage becomes increasingly positive, the surface shrinks toward the filament and an increasing number of electrons flow to the plate. When the plate voltage reaches a high positive value, the surface coincides with the surface of the filament and all of the emitted electrons flow to the plate. In general, the plate current cannot exceed this value, which is called the saturation current, excepting for the possibility at very high voltages of actually pulling electrons out of the filament and hence increasing the effective emission from the filament.

QUESTION #11. Draw an EG-IG curve and explain.

ANSWER #11. See Curve #1 in back of weeks work. This curve shows the the current which flows to the grid for different values of grid voltage. Practically no current flows to the grid when it is negative, but it commences to flow more and more as the grid becomes positive, because some of the electrons, which are on their way to the plate, are attracted to the grid. The currents to the grid are very small compared to the currents in the plate circuit; the grid currents are measured in microamperes, or millionths of an ampere, while the plate currents are measured in milliamperes, or thousandths of an ampere. The grid current is of importance in the action of the vacuum tubes as a detector when a grid condenser and grid leak are used, and also is of some importance in connection with amplifiers.

QUESTION #10. Draw an EP-IP characteristic curve and explain.

ANSWER #10. See Curve #2 in back of weeks work. In this curve is shown in solid line the characteristic curve of a two-electrode tubes, showing the variation of current with B battery voltage. The flat part of the curve, CD, represents the maximum current that can flow through the tube. The current can not go higher, because all the electrons emitted by the filament flow to the plate as fast as they are emitted. For lower plate voltages the current is less; and, since the number of electrons emitted by the filament is unchanged, it follows that only a portion of the emitted electrons are flowing across to the plate. The reason for this was explain in question number nine under explanation of space charge. If the temperature

ANSWER #10. Continued.

of the filament is increased, the rising portion of the curve is very nearly unchanged. The curve will, however, rise to a higher value before flattening out, as shown by the dotted line. This higher value corresponds to the increased emission of electrons from the filament.

QUESTION #12. Draw an IP-EG curve and explain.

ANSWER #12. See Curve #3 in back of weeks work. The control which the grid exerts on the plate current is shown by the characteristic curve representing the relation between plate current and grid voltage. The curve shown is for a type of tungsten filament receiving tube with a plate current of 60 volts and a filament current of 0.65 ampere. The current which heats the filament also produces a drop in potential along the filament so that when one speaks of the grid or plate being so many volts positive with respect to the filament, a particular point on the filament must be specified. Usually it is customary to take the terminal of the filament which is connected to the negative terminal of the filament battery as the point of zero potential, and the grid and plate voltages are then measured relative to this point. Thus in the accompanying curve the grid and plate voltages are measured relative to the negative filament terminal. The grid is at zero voltage when it is connected to the negative filament without any C battery. This curve is of main importance in explaining how the vacuum tube operates.

QUESTION #13. By the use of the IP-EG characteristic curve, explain how a vacuum tube may be used as an amplifier or a detector (Curves of plate current must accompany explanation).

ANSWER #13. As an amplifier. Assume that the vacuum tube, for which the grid voltage-plate current curve is given in Curve #3, is operated under the conditions of plate voltage and filament current there stated. Suppose that no grid battery is used so that the grid voltage is zero. The operating conditions of the vacuum tube will then correspond to the point marked A on the curve and the plate current will be about 0.7 ma. If, now, an alternating voltage is impressed upon the grid so that its voltage varies above and below the steady value, then, as the grid voltage varies up and down, the plate current will similarly rise and fall. In Curve #4a (In back of weeks work) it shows the assumed variation in the grid voltage which is taken to have an amplitude which carries the grid up to Plus 2 volts and down to Minus 2 volts. From Curve #3 it is seen that for Plus 2 volts the plate current will be a little over 1.0 ma, and for Minus 2 volts will be about 0.3 ma. Hence the plate current will vary about as shown in Curve 4b. The plate current curve is of the same form as the voltage curve, because the region of the variation was taken over a part of the characteristic that was nearly straight. A slight variation in grid voltage will produce the same variation in the plate current but the plate current will be about ten or twenty times the value of the grid current, thus the input power will be amplified ten or twenty times its original value.

ANSWER #13. Continued.

As a detector. Now let the grid battery be such as to make the grid 4 volts negative, corresponding to the point B of Curve #3. Then, with the same alternating voltage as before impressed upon the grid, the grid voltage will vary between Minus 2 and Minus 6 volts. The plate current for Minus 4 volts grid voltage is about 0.1 ma, but the decrease to Minus 6 volts will produce only a slight reduction in the plate current below the value for Minus 4 volts because of the bend in the curve. The variation in the plate current in this case will be a curve such as that shown in Curve #4c which is quite distorted in form from that of the grid voltage. The distortion results for the reason that the variation takes place over a bending portion of the curve. Because of the distorted form of the wave in Curve 4c it is evident that the average value of the current is greater when the alternating voltage is applied than it would be if no such voltage were acting on the tube. Since direct current instruments respond to the average value of the current flowing through them, a direct current ammeter in the plate circuit of the vacuum tube, under the conditions assumed for Curve 4a and 4b, would show no change in reading when the alternating voltage is applied to the vacuum tube; it would, however, show an increased reading under the conditions of figure in Curve 4c upon the application of the alternating voltage. This change in average value of the current is of vital importance in the operation of the vacuum tube as a detector.

QUESTION #14. Explain how input conductance may be found from characteristic curve.

ANSWER #14. It is shown that Ohm's law holds good for parts of AC circuits where the current is in phase with the emf. So to find the conductance, which is the reciprocal of resistance, we merely divide the current through that circuit by the voltage across that circuit. The input conductance is the grid conductance and can be found from the EG-IG curve by drawing a tangent from portion of the curve being used. The AC will be undistorted and proportional to the applied voltage if the curve is straight. The curve will be straight if only a limited portion of the curve is utilized. This tangent to the curve nearly coincides with the curve in a limited region around the point of tangency. If an alternating voltage is superimposed upon the steady voltage acting in the grid circuit, the total voltage will vary a certain amount in one direction and an equal amount on the other side. Correspondingly the current will increase by an amount equal to the opposite side of a triangle formed by drawing the tangent, and then decrease by an equal amount. The amplitude of the voltage is given by the adjacent side of the triangle and the amplitude of the current by the opposite side. The conductance g is given by I_{max} divided by E_{max} , that is, the ratio of the maximum current to maximum emf. Therefore Conductance equals opposite side divided by adjacent side equals $\tan \theta$ equals slope of the tangent to the curve

QUESTION #15. Why should input conductance of an amplifier tube be small?

ANSWER #15. The input power to the vacuum tube, or the power which the tube takes from the circuit connected to the input vacuum tube, depends upon the alternating grid current. In general, it is desirable to reduce this power as much as possible in order to increase the efficiency of the vacuum tube as an amplifier. Since the input power to the vacuum tube is dependent upon the product of the input voltage and input current, it is desirable, in order to make this input power very small, to make the grid conductance (input conductance) very small, by adjusting the steady voltage of the grid to be near zero or even somewhat negative.

QUESTION #16. Explain by use of characteristic curve how mutual conductance may be found.

ANSWER #16. The mutual conductance is obtained from the EG-IP curve. The slope of this curve at any point gives what is called the mutual conductance of the tube and is a measure of the alternating current which flows in the plate circuit of the tube for a given applied voltage on the grid provided there is no appreciable resistance or reactance in the plate circuit of the tube external to it.

QUESTION #17. What is meant by amplification constant of tubes and how is it determined?

ANSWER #17 The amplification constant of vacuum tubes is a factor which determines the amount of voltage flowing in the plate circuit for any load and from which can be found the current flowing in the plate circuit. This amplification is found by using both the EG-IP and the EP-IP curves and after several transpositions of several formulae the formula for amplification constant boils down to the mutual conductance divided by the plate conductance

QUESTION #18. Explain how external plate resistance effects the operation of a vacuum tube used as an amplifier (Sketch and equations.).

ANSWER #18. In the case of a pure resistance in the external circuit the alternating current in the plate circuit is exactly in phase with both the grid voltage and the plate voltage and the formula for finding the resultant plate current is:

$$I_p = \frac{\mu \times E_g}{R_p \text{ plus } R}$$

Sketch of pure resistance in external circuit:

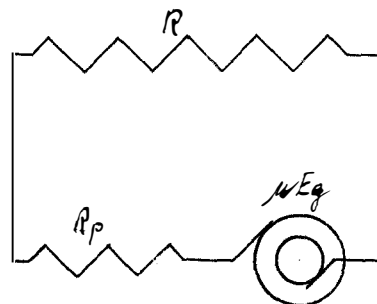

ANSWER #18. Continued.

In the case of any impedance whatsoever in the external circuit, the magnitude and phase of the plate current can be calculated just as simply as in the case of ordinary simple ac circuits. It is necessary only to assume that the emf $\mu \times E_g$ is acting in a circuit which has in series the resistance R_p and the inserted impedance. In the case of inductance only in the circuit, the formulae are:

$$Z = \sqrt{(R_p \text{ plus } R)^2 \text{ plus } (\omega L)^2}$$

$$I_p = \frac{\mu \times E_g}{\sqrt{(R_p \text{ plus } R)^2 \text{ plus } (\omega L)^2}}$$

$$\phi = \tan^{-1} \frac{\omega L}{R_p \text{ plus } R}$$

Where: Z = impedance in ohms.
 R_p = plate resistance (internal)
 R = plate resistance (external)
 ω = $2\pi \times F$
 I_p = plate current
 μ = amplification constant.
 E_g = grid voltage.
 ϕ = phase angle in degrees.

Sketch of simple ac circuit, the equivalent of the Plate circuit with impedance in series:

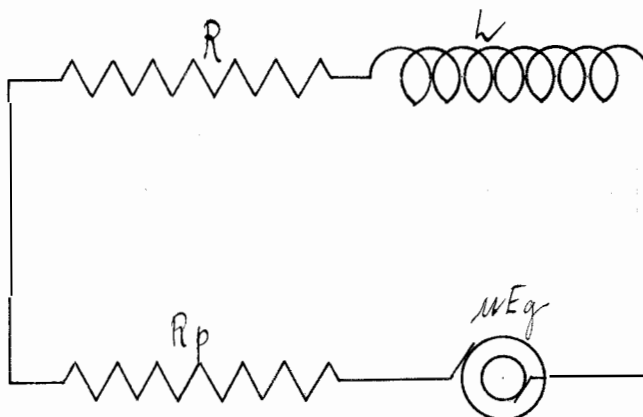

QUESTION #19. Explain and show by sketch how regenerative amplification is accomplished.

ANSWER #19. It is possible to increase very decidedly the amplification obtained by a single vacuum tube by what is known as regeneration. Below is sketch of circuit. The coil L_1 is called the tickler, or feed back coil. The action is as follows: The emf E causes an alternating current to flow in the tuned circuit and gives rise to E_g across the condenser C which is applied between the grid and filament of the tube. The voltage on the grid of the vacuum tube causes an alternating current to flow in the plate circuit. The current flows through the coil L_1 and by reason of the coupling with L , induces an emf in coil L which with proper coupling will be nearly in phase with and will add to the original emf E_g . The addition of this voltage leads to an increase in the current in the LC circuit and also to an increase in the voltage applied to the vacuum tube. The plate current is likewise increased and a still larger emf is fed back thru L_1 to the LC circuit. This cycle is repeated over and over but usually in a short time a stable condition is reached in which much larger currents and voltages are present in all parts of the circuit than would be present if the feed-back feature were absent. This stable condition is reached if the emf fed back is less than the original emf. The final emf and with it currents and voltages in all portions of the circuit will be doubled.

Sketch of circuit:

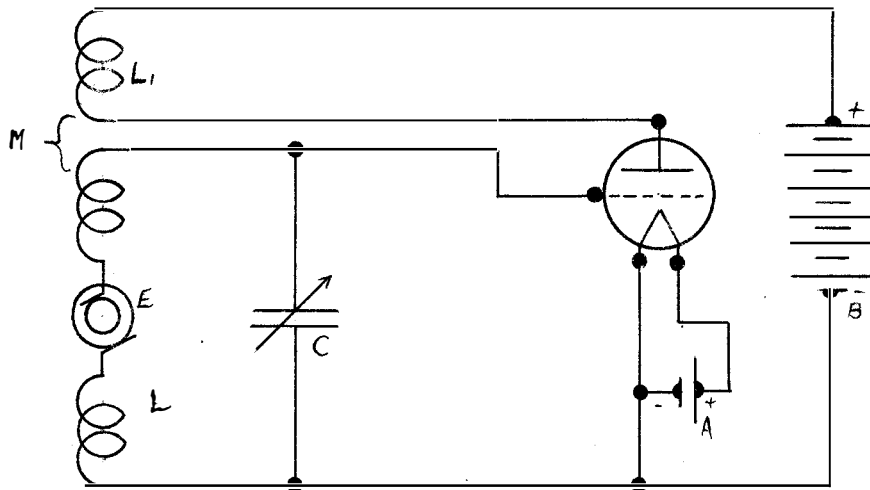

QUESTION #20. What limits the amplitude of regenerative amplification?

ANSWER #20. The limit of amplitude of regenerative amplification is the point where the vacuum tube starts to oscillate. This point is reached by varying the coupling between the two coils so that the emf keeps building up until the tube self-generates oscillations. Theoretically, the amplification becomes higher and higher without limit as the oscillation point is approached but practically after a certain degree of amplification is obtained the adjustments become so critical that any slight disturbance such as static or variation in battery voltage, will start the vacuum tube oscillating.

QUESTION #21. Explain the grid method of detection.

ANSWER #21. Detection with a three electrode vacuum tube with grid condenser and grid leak resistance, is called the grid method of detection. The alternating current picked up by the antenna is impressed on the grid. When a train of oscillations comes in, the grid voltage will swing positive and negative; on the positive swing the grid current will increase considerably, while on the negative swing the reduction in grid current will be slight. In effect, the average grid current will increase during the oscillations. The plate current will follow all changes in the grid voltage, so that the wave form of the plate current will resemble the grid voltage curve. The radio-frequency portion of the plate current oscillations will flow through the telephone condenser, but, corresponding to the decrease in the average value of the grid voltage the current through the telephones will be reduced during each wave train producing a note in the telephones of the same pitch as the wave train frequency. In the case of detection with grid condenser and grid leak there is a reduction in telephone current during the wave train, which results from the curvature of the grid current characteristic. The grid condenser is placed between the grid and the coil so that no charge can go from the grid to the filament and the antenna. The grid leak is connected between the grid and the filament so that the charge will not pile up on the grid and make its action erratic. This leak allows the grid to clear itself between oscillations and be ready to respond to the changes in voltage across the inductance coil.

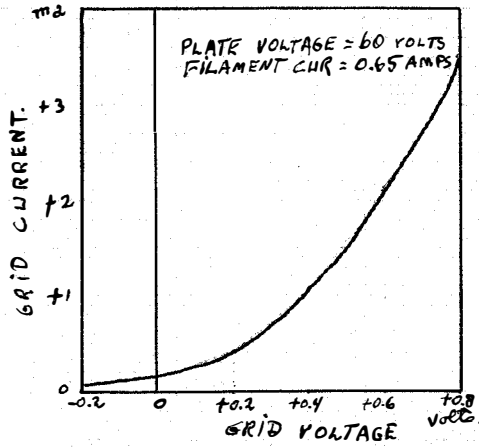

Question #11 - Curve #1

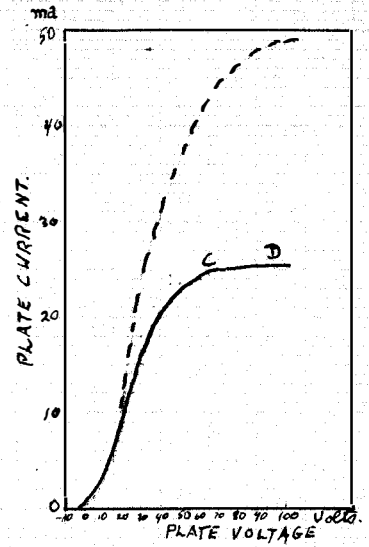

Question #10 - Curve #2

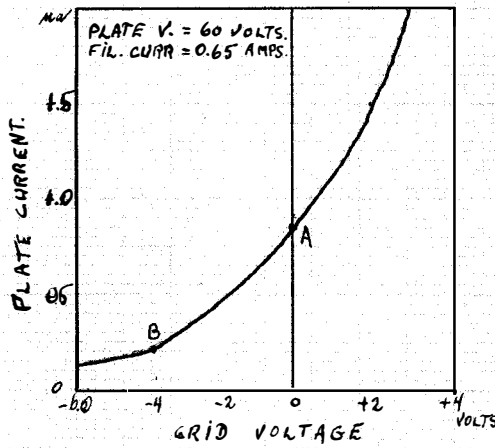

Question #12 - Curve #3

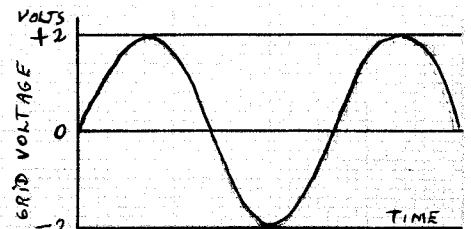

Question #13 - #4a

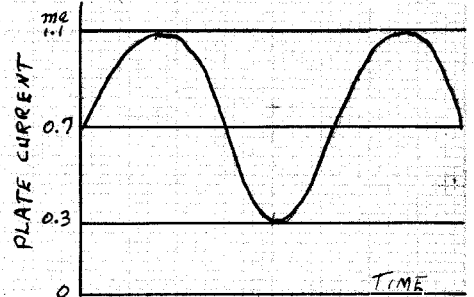

Curve #4b

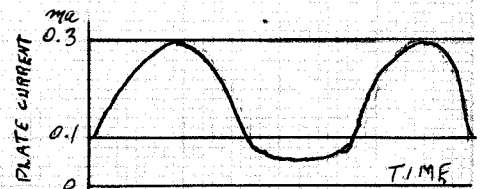

Curve #4c