

# INSTRUCTION MANUAL

FOR

PANORAMIC

SPECTRUM ANALYZER

MODELS SPA-3 & SPA-3/25

AND ACCESSORIES



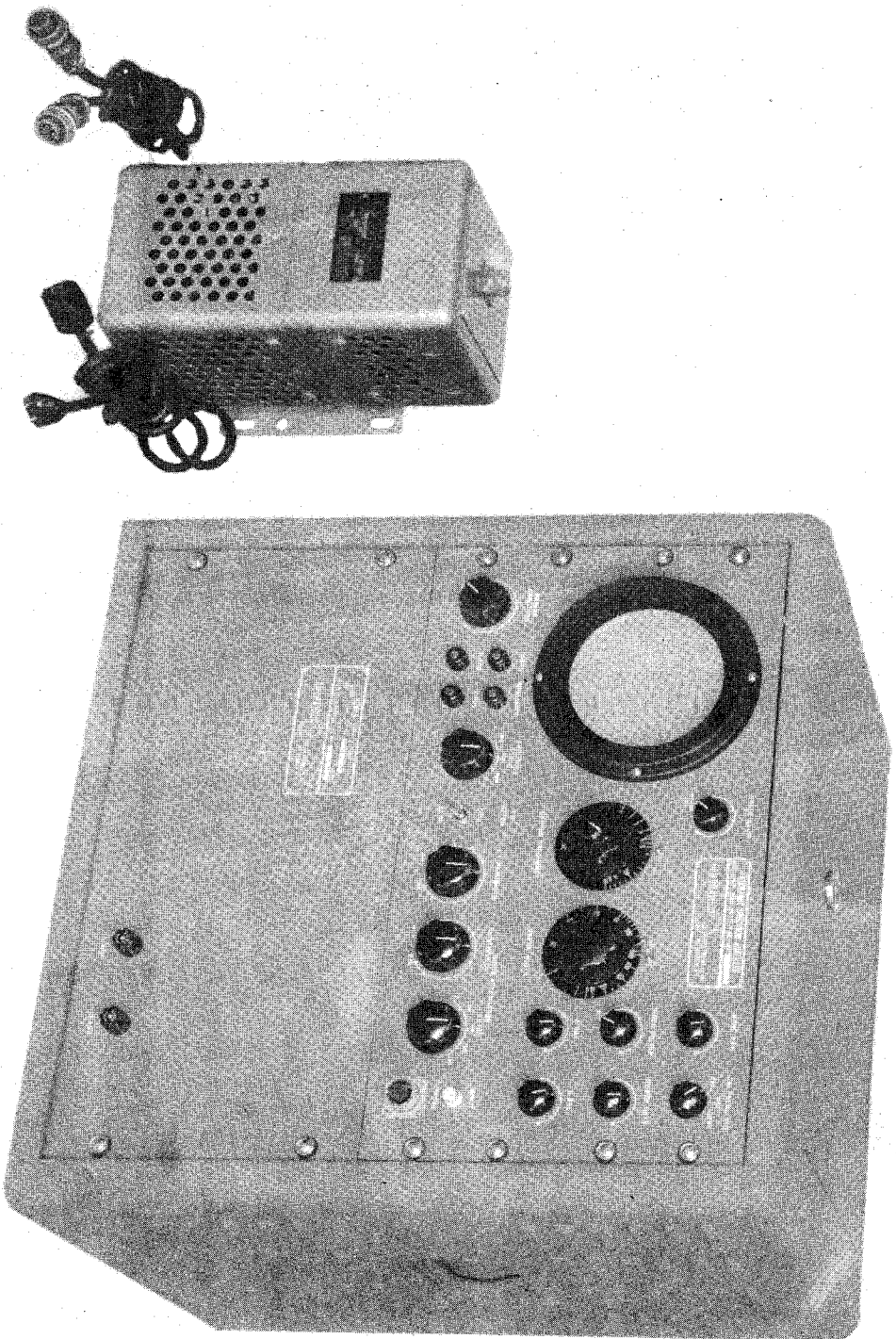

Figure I-1. Panoramic Spectrum Analyzer, Model SPA-3.

## TABLE OF CONTENTS

|   | <u>Page</u> |
|---|-------------|
| CHAPTER I - INTRODUCTION .....  | 1           |
| I-1. General .....  | 1           |
| I-2. Applications .....   | 1           |
| I-3. General Description .....  | 3           |
| I-4. Equipment Supplied .....   | 4           |
| I-5. Electrical Characteristics .....   | 5           |
| I-6. Physical Characteristics .....   | 10          |
| I-7. Tube Complement .....  | 10          |
| I-8. Terms and Definitions .....  | 12          |
| <br>CHAPTER II - INSTALLATION .....   | <br>17      |
| II-1. Unpacking and Initial Inspection .....                                    | 17          |
| II-2. Mounting .....  | 17          |
| II-3. Interconnecting Procedure .....   | 22          |
| II-4. Installation Adjustments and Checks .....                                 | 23          |
| <br>CHAPTER III - OPERATING INSTRUCTIONS .....                                  | <br>29      |
| III-1. Operating Controls .....   | 29          |
| III-2. Semi-Adjustable Operating Controls .....                                 | 32          |
| III-3. Preliminary Adjustments .....  | 33          |
| III-4. Operating Techniques .....   | 35          |
| <br>CHAPTER IV - THEORY OF OPERATION .....                                      | <br>55      |
| IV-1. Introduction .....  | 55          |
| IV-2. Circuit Description, Models SPA-3 and SPA-3/25,<br>Analyzer Section ..... | 56          |
| IV-3. Circuit Description, Model PS-19 .....                                    | 64          |
| <br>CHAPTER V - SERVICE AND MAINTENANCE .....                                   | <br>67      |
| V-1. Trouble Shooting .....   | 67          |
| V-2. Touch-Up Alignment .....   | 81          |
| V-3. Service, Controls and Factory-Adjusted Components .....                    | 86          |
| V-4. Complete Field Alignment Procedure .....                                   | 89          |
| V-5. Final Test Procedure .....   | 97          |
| <br>CHAPTER VI - ACCESSORY EQUIPMENT .....                                      | <br>105     |
| VI-1. Cathode Follower Probe, Model PRB-1 .....                                 | 105         |
| VI-2. Signal Alternator, Model SW-1 .....                                       | 110         |
| <br>CHAPTER VII - LIST OF REPLACEABLE PARTS .....                               | <br>115     |
| VII-1. Introduction .....   | 115         |
| VII-2. List of Replaceable Parts .....  | 115         |

*ready*

LIST OF ILLUSTRATIONS

| <u>Figure No.</u> |  | <u>Page</u>  |
|-------------------|--|--------------|
| I-1.              | Panoramic Spectrum Analyzer, Model SPA-3 -----   | Frontispiece |
| I-2.              | Resolution Versus Sweep Width -----  | 8            |
| I-3.              | Minimum Frequency Spectrum F Required<br>to Measure Amplitude Ratios $E/2/E_1$ -----                 | 9            |
| I-4.              | Front Panel, Model SPA-3, Analyzer Section -----   | 14           |
| I-5.              | Front Panel, Model SPA-3/25, Analyzer Section -----  | 15           |
| I-6.              | Front Panel, Model PS-19 -----   | 16           |
| II-1.             | Outline Dimensional Drawing. Models SPA-3 and<br>SPA-3/25 (including Model PS-19), Cabinet Mounted - | 18           |
| II-2.             | Outline Dimensional Drawing, Analyzer Section,<br>Rack-Mounted Style -----                           | 19           |
| II-3.             | Outline Dimensional Drawing, Model PS-19,<br>Rack-Mounted Style -----                                | 20           |
| II-4.             | Outline Dimensional Drawing, Constant Voltage<br>Transformer -----                                   | 21           |
| III-1.            | Correct Viewing of CRT Screen -----  | 33           |
| III-2.            | Zero-Frequency Pip -----   | 34           |
| III-3.            | Marker Presentation -----  | 34           |
| III-4.            | Voltage Ratio - Decibel Conversion Chart -----   | 40           |
| III-5.            | Measurement of Closely-Spaced Unequal Amplitude<br>Signals -----                                     | 41           |
| III-6.            | Typical Screen Presentations - VIDEO FILTER<br>Control Adjustment -----                              | 42           |
| III-7.            | Typical Screen Presentations - IF BANDWIDTH<br>Control Adjustment -----                              | 45           |
| III-8.            | Typical Screen Presentations for Discrete Signals -----  | 50           |
| III-9.            | Typical Screen Presentations for Noise Signals -----   | 51           |
| IV-1.             | Block Diagram, Analyzer Section -----  | 54           |
| V-1.              | Stage Gain Measurement Circuit -----   | 79           |
| V-2.              | Crystal Rejection Slot Removal -----   | 92           |
| VI-1.             | Schematic Diagram. Cathode Follower Probe,<br>PRB-1 -----  | 109          |
| VI-2.             | Schematic Diagram. Signal Alternator, Model SW-1 ---   | 114          |

## PRODUCTION CHANGES

Models SPA-3 and SPA-3/25

Model SPA-3 Serial Numbers 169P--- and above.

Model SPA-3/25 Serial Numbers 199E--- and above.

The following modifications have been made in these instruments. Appropriate changes should be made in the text of this Manual to cover these modifications.

1. The rotary INPUT ATTENUATOR-STEP switch has been replaced with 3 toggle switches. These switches provide 20 DB, 20 DB and 40 DB of attenuation as indicated by the front panel markings.
2. The positions of the INPUT and PROBE connectors have been reversed. The PROBE connector has been changed from the type illustrated.
3. The following changes should be made to the list of replaceable parts.

Delete the following components:

| Ref<br>Symbol | Description   |
|---------------|---|
| J101          | Connector: receptacle BNC, Mil Type UG-910/U<br>Pan Part J2044        |
| J103          | Connector: receptacle, 5 pin<br>Pan Part J2028                        |
| S101          | Switch: rotary, ceramic wafer,<br>Pan Part S1-10746                   |
| R125          | Resistor: variable, composition, 5,000 ohms,<br>Pan Part RVA-502AQ-2J |
| R123          | Resistor: fixed composition<br>Factory Adjust                         |
| R103*         | Resistor: fixed metal film,   |
| R107*         | 713 ohms, $\pm 1\%$ , 1/2 W   |
| R111*         | Pan Part RC20AZ7130F  |
| R115*         |   |

| Ref<br>Symbol                        | Description  |
|--------------------------------------|--|
| R103**<br>R107**<br>R111**<br>R115** | Resistor: fixed, metal film,<br>495 ohms, $\pm 1\%$ , 1/2 W<br>Pan Part RC20AZ4950F  |
| R105*<br>R109*<br>R113*              | Resistor: fixed, metal film,<br>88 ohms, $\pm 1\%$ , 1/2 W<br>Pan Part RC20AZ880F    |
| R101**<br>R117**                     | Resistor: fixed, metal film,<br>79.2 ohms, $\pm 1\%$ , 1/2 W<br>Pan Part RC20AZ79P2F |
| R105**<br>R109**<br>R113**<br>R117** | Resistor: fixed, metal film,<br>61 ohms, $\pm 1\%$ , 1/2 W<br>Pan Part RC20AZ610F    |
| R101*                                | Resistor: fixed, metal film,<br>55 ohms, $\pm 1\%$ , 1/2 W<br>Pan Part RC20AZ550F    |
| C102<br>C104                         | Capacitor: fixed, silvered mica,<br>220 uuf, (C104 factory adjust)                   |

Add the following components:

| Circuit<br>Ref<br>Symbol | Description  | Mfr &<br>Mfrs No. | Qty in<br>Set |
|--------------------------|--|-------------------|---------------|
| J103                     | Connector: receptacle, 4 contact,<br>female, microphone type<br>Pan Part J2071 | AB<br>91PC4F      | 1             |
| J501                     | Connector: receptacle, BNC, D type,<br>Mil Type UG-1094/M                      | AB<br>31-221      |               |
| J502                     | Connector: receptacle, BNC,<br>Mil Type UG-1098/U, right angle                 | AB<br>31-222      | 1             |

| Circuit Ref Symbol                        | Description  | Mfr & Mfrs No.         | Qty in Set |
|---|--|------------------------|------------|
| S501<br>S503<br>S505                      | Switch, toggle, DPDT<br>Pan Part S1-12051A   | AT<br>S1-12051A        | 3          |
| R521                                      | Resistor: variable, composition,<br>linear, 100 ohms, $\pm 10\%$ , 2 W<br>Pan Part RVA101AQ-2J | AA<br>RV4NAY<br>SD101A | 1          |
| R523                                      | Resistor: fixed, composition,<br>5.6 ohms, $\pm 5\%$ , 1 W<br>Pan Part RC32BX05P6J             | AA<br>GB56G1           | 1          |
| R519                                      | Resistor: fixed, composition,<br>200 ohms, $\pm 5\%$ , 1/2 W<br>Pan Part RC20BX201J            | AA<br>EB2015           | 1          |
| R507*<br>R511*<br>R513*<br>R517*<br>R519* | Resistor: fixed, composition,<br>88 ohms, $\pm 1\%$ , 1/2 W<br>Pan Part RC20AZ88P0F-9          | BE<br>Type<br>C1/2C    | 5          |
| R509*<br>R515*                            | Resistor: fixed, composition,<br>356.4 ohms, $\pm 1\%$ , 1/2 W<br>Pan Part RC20AZ365P4F-9      | BE<br>Type<br>C1/2C    | 2          |
| R503*                                     | Resistor: fixed, composition,<br>3600 ohms, $\pm 1\%$ , 1/2 W<br>Pan Part RC20AZ3601F-9        | BC<br>Type<br>C1/2C    |            |
| R501*<br>R505*                            | Resistor: fixed, composition,<br>73.4 ohms, $\pm 1\%$ , 1/2 W<br>Pan Part RC20AZ73P4F-9        | BC<br>Type<br>C1/2C    |            |

| Circuit Ref Symbol   | Description  | Mfr & Mfrs No.      | Qty in Set |
|--|--|---------------------|------------|
| R501**<br>R503**<br>R505**<br>R507**<br>R509**<br>R511**<br>R513**<br>R515**<br>R517**<br>R523** | Resistor: fixed composition,<br>±1%, 1/2 W<br>factory adjust component<br>See schematic diagram for actual<br>value. | BC<br>Type<br>C1/2C |            |
| C501*  | Capacitor: fixed, silvered mica,<br>120 uuf, ±5%<br>Pan Part CM15C121J   | AL<br>CM15C121J     | 1          |
| C501**   | Capacitor: fixed, silvered mica,<br>factory adjust component   | AL<br>Type<br>CM20  |            |
| P502   | Receptacle: BNC, Mil Type UG 260/U<br>Pan Part 2010  | AB<br>31-012        | 1          |

Change the following to read:

| Circuit Ref Symbol | Description  | Mfr & Mfrs No.  | Qty in Set |
|--------------------|--|-----------------|------------|
| C259               | Capacitor: fixed, silvered mica,<br>470 uuf, ±5%<br>Pan Part CM15C471J         | AL<br>CM15C471J |            |
| C261               | Capacitor: fixed, silvered mica,<br>470 uuf, ±5%<br>Pan Part CM15C471J         | AL<br>CM15C471J |            |
| R403               | Resistor: fixed, composition,<br>4,700 ohms, ±5%, 1/2 W<br>Pan Part RC20BX472J | AB<br>EB4725    | 1          |



Change the following items:

|      |                           |   |
|------|---------------------------|---|
| J105 | Change Qty in Set to read | 8 |
| C204 | Change Qty in Set to read | 3 |
| C329 | Change Qty in Set to read | 2 |

\* 72 ohm input

\*\* 50 ohm input

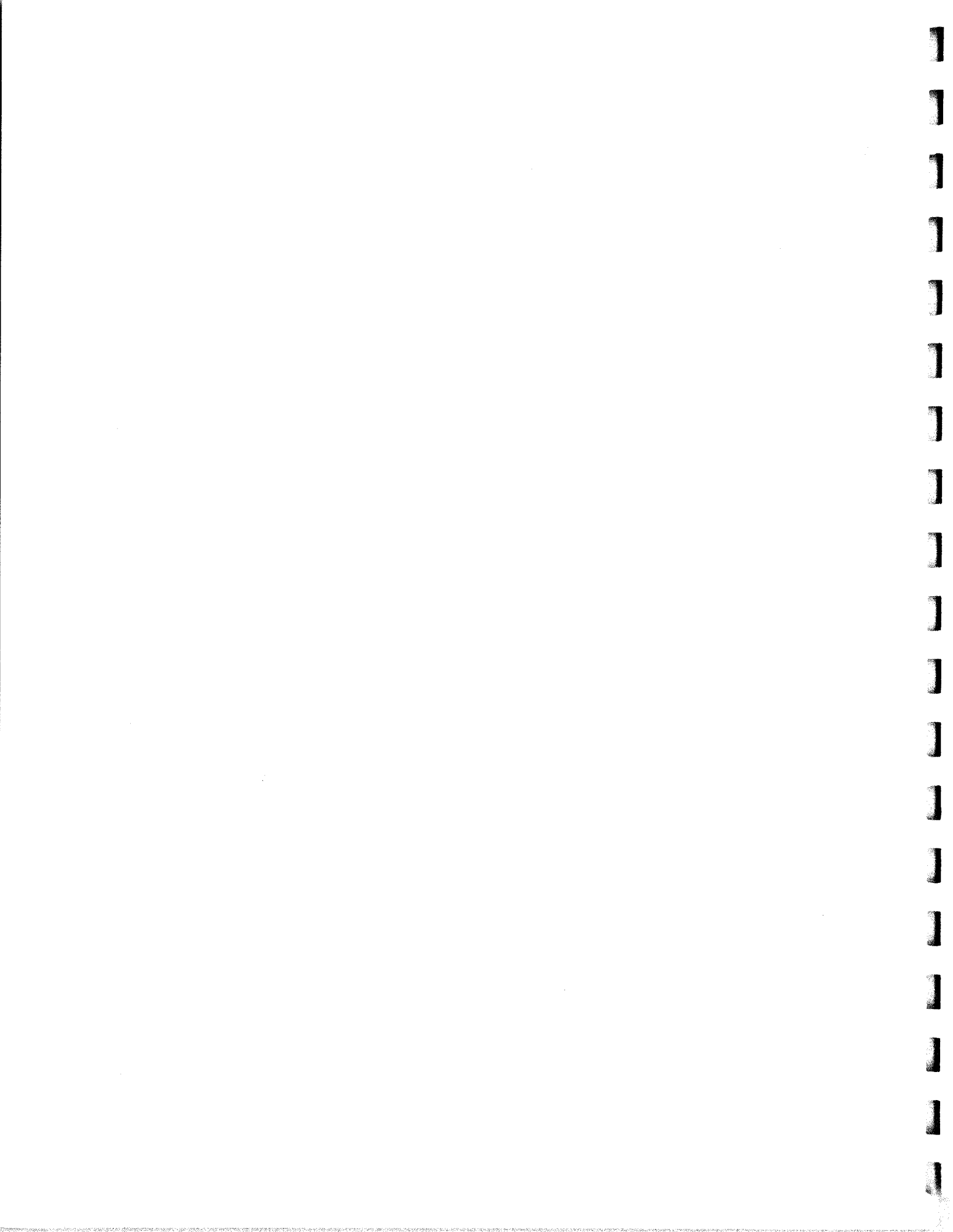

## CHAPTER 1 INTRODUCTION

### I-1. GENERAL.

This Instruction Manual contains information concerning electrical and physical characteristics, applications, installation, and operation of the Panoramic Spectrum Analyzers, Models SPA-3 and SPA-3/25, as well as information concerning maintenance and servicing. Information also is provided for various accessory equipment which may be used with the spectrum analyzer.

No attempt to operate the equipment should be made until the user is thoroughly familiar with the information contained in Chapter III, OPERATING INSTRUCTIONS.

### I-2. APPLICATIONS.

The Panoramic Spectrum Analyzers, Models SPA-3 and SPA-3/25 (with associated power supply, Model PS-19) provide a simple, reliable method for analysis or monitoring of complex discrete signals and/or noise in the frequency region of 200 cps to 15 mc (to 25 mc with the Model SPA-3/25).

The equipment provides an automatic, visual presentation (on the screen of a long-persistence cathode-ray tube) of the frequency and amplitude of signals present in the frequency region of 200 cps to 15 mc (to 25 mc with the Model SPA-3/25) for such studies as harmonic content, cross-modulation products, filter and transmission-line checks, vibration measurement, and telemetry-channel monitoring.

The equipment can be used to display modulated signals (am, fm, pulse, or combinations) to measure energy distributions and to look for such effects as unwanted or excessive modulations, linearity of deviations, hum and noise, and otherwise undetectable parasitic oscillations. Other dynamic phenomena such as crowded communications channels, oscillator or carrier instability, and noise spectra can be studied. Both the direction and magnitude of changes caused by deliberate or random change of circuit or operating parameters, mechanical shocks, environmental changes, etc. can be seen instantly.

The designed versatility of the unit permits selection of center frequency, sweep width, sweep rate, intermediate-frequency bandwidth, and type of amplitude scale. The equipment enables the selection and detailed analysis of a narrow band which may contain signals separated by as little as 200 cps.

Once the norms for an application are established, nonprofessional personnel in the laboratory or factory easily can use the equipment to provide a graphic

visualization of spectrum content. Yet the equipment is critically designed for laboratory investigations on the research and development levels.

In order to obtain a minute examination of modulated signals or groups of adjacent signals the SPA-3 can be conditioned readily to select for presentation any 0 to 3 mc band between 200 cps and 15 mc (between 200 cps and 25 mc with the SPA-3/25). This is particularly useful when the system usage involves modulated signals or closely-spaced signals since an expanded presentation of just those adjacent signals that are being analyzed can be obtained. A Panoramic display of the signals permits identification of unwanted effects at a glance thereby affording a quick appraisal of those above tolerable levels. Since such observations can be employed without resorting to special and more difficult instruments and procedures, routine signal inspection with the Panoramic Spectrum Analyzer will pinpoint difficulties and allow preventive action to be taken before important system failure is expensively revealed.

The scope and facility of measurement with the Panoramic Models SPA-3 and SPA-3/25 can be extended by using it in conjunction with certain compatible Panoramic and commercially available equipments.

- + The amplitude-versus-frequency response of systems and devices can be determined in the frequency region between 200 cps and 15 mc using the accessory Panoramic Video Response Indicator, Model G-6.
- + To facilitate comparison of two input signals (comparing two similar test signals; comparing a test signal to a standard, known signal; etc.), the Panoramic Signal Alternator, Model SW-1, can be used to alternate the two inputs to the spectrum analyzer.
- + To drive auxiliary slave indicators, the equipment provides an auxiliary vertical output.
- + To synchronize the Model SW-1, camera shutters, and/or auxiliary slave indicators, a pulse output is provided by the spectrum analyzer. This pulse output is in synchronism with the sweep of the spectrum analyzer.
- + To permit aural monitoring at zero sweep width, detected output is available from the spectrum analyzer.
- + To permit connection of signals from a high-impedance source, a special probe, Model PRB-1, is required. This probe is supplied only if ordered.
- + A Polaroid-type oscilloscope camera suitable for screen photography may be obtained from Panoramic Radio Products, Inc. The SPA-3 and SPA-3/25 camera-mounting bezels are designed to accommodate this camera.

### I-3. GENERAL DESCRIPTION.

The Panoramic Spectrum Analyzer is a scanning heterodyne instrument. It automatically provides a visual, two-dimensional display of the frequency components of a complex wave, in any selected 0- to 3-mc segment of the region between 200 cps and 15 mc (25 mc with the SPA-3/25). The display appears on the screen of long-persistence, flat-faced, cathode-ray tube, as vertical deflections distributed horizontally in order of component frequency. The frequency presentation is linear. The height of a given vertical deflection indicates the relative magnitude of its corresponding frequency component.

The spectrum analyzer consists basically of a calibrated input attenuator, an input cascode amplifier, a wide-band amplifier (SPA-3/25 only), a phase splitter, a sweeping oscillator, a balanced mixer, an intermediate-frequency-section attenuator, a 32-mc if amplifier, a 29.3-mc crystal oscillator, a second mixer, variably selective intermediate-frequency amplifiers (2.7 mc), a detector, vertical and horizontal deflection amplifiers, a sawtooth generator, and a cathode-ray-tube indicator.

The sweeping oscillator progressively heterodynes, in order of frequency, with those signals at the output of the phase splitter to produce, among the mixing products, a sum frequency which is applied to the 32-mc intermediate-frequency section. A balanced modulator is employed to eliminate spurious modulation products and prevent passage of the sweeping-oscillator frequency into the 32-mc if section. The output of the 32-mc if section is mixed with the output of the 29.3-mc crystal oscillator.

The 2.7-mc product of this mixing passes through a 2.7-mc variably selective if section. The output voltage of the 2.7-mc if section is proportional to the amplitude of the sampled portion of the input signal. This output is detected, amplified, and applied to the vertical deflection plates of the cathode-ray tube. The vertical deflection appears at a definite location along the horizontal axis according to signal frequency since a common sawtooth voltage source is used for both the sweeping oscillator and the horizontal deflection of the crt beam.

Oscillator sweep is obtained with a sawtooth-modulated circuit (consisting basically of a voltage-controlled tuning inductor) which controls the frequency of the oscillation. A calibrated SWEEP WIDTH control varies the amplitude of the modulating sawtooth to permit selection of any sweep width from 0 to 3 mc. A calibrated CENTER FREQUENCY control tunes the swept oscillator to permit selection of any center frequency between 0 and 13.5 mc (0 and 23.5 mc in the case of the SPA-3/25).

In order to satisfy a very broad application range, the equipment incorporates independent SWEEP WIDTH, IF BANDWIDTH, and SWEEP RATE controls. For example, there are cases where high probability of signal intercept is paramount. This requires short scan intervals, hence the variable SWEEP RATE

control and an IF BANDWIDTH control to obtain a suitable intermediate-frequency section bandwidth for the selected scanning velocity (product of sweep width and sweep rate). In other instances, for statistical purposes it may be necessary to scan slowly yet maintain a broad intermediate-frequency section bandwidth.

Three different amplitude scales can be selected, a linear scale calibrated in 10 divisions, a logarithmic scale calibrated from 0 db to 40 db in 5-db divisions, and a power scale wherein an approximately 2 to 1 voltage ratio provides a 4 to 1 ratio of screen deflection. The power scale is particularly useful for evaluating power levels, half-power points, and for critical amplitude comparison between signals of similar amplitude.

The Models SPA-3 and SPA-3/25 and the companion power supply, Model PS-19, normally are supplied mounted in a common carrying case. However, when removed from the carrying case, the units can be mounted in a standard, 19-inch, electrical-equipment rack.

Screen observations and photography are facilitated by providing a flat-faced cathode-ray tube (type 5ADP7), edge lighting for the crt, and a camera mounting bezel. A Polaroid-type oscilloscope camera, specifically intended for use with the SPA-3 and SPA-3/25 mounting arrangements, can be purchased from Panoramic Radio Products, Inc.

The equipment normally is supplied for operation from a 95- to 130-volt, 60-cps single-phase power source. If so ordered, it can be supplied to operate from a 190- to 260-volt and/or 50-cps line.

#### I-4. EQUIPMENT SUPPLIED.

| <u>Description</u>  | <u>Quantity</u> |
|---|-----------------|
| Analyzer section of Panoramic Spectrum Analyzer,<br>Model SPA-3 or SPA-3/25 -----               | 1               |
| Panoramic Power Supply, Model PS-19 -----   | 1               |
| Constant-Voltage Transformer, Panoramic No. T3017-1<br>(modified Sola No. 20-13-125)* -----     | 1               |
| Interconnecting cable, power, 14 wire, SPA-3 or SPA-3/25<br>to PS-19, Panoramic No. W3060 ----- | 1               |

\* Other constant-voltage transformers supplied if specified on purchase order.

| <u>Description</u>  | <u>Quantity</u> |
|---|-----------------|
| Interconnecting cable, power, 5 wire, PS-19 to CV<br>Transformer, Panoramic No. W3030 ----- | 1               |
| Line cord, ac, 3 wire (with adapter for 2-wire power line),<br>Panoramic No. W3033 -----    | 1               |
| Key for #4 multiple-spline socket screw -----   | 1 *             |
| Key for #6 4-point-spline socket screw -----  | 1 *             |
| Key for #8 multiple-spline socket screw -----   | 1 *             |
| Tool, Alignment, Walsco #2543 -----   | 1 *             |
| Tool, Alignment, Cambridge Thermionic #X2033 -----  | 1 *             |
| Spare Fuse, cartridge, 3 a, 250 v, Type 3 AG -----  | 2 **            |

I-5. ELECTRICAL CHARACTERISTICS.

a. Frequency Range.

SPA-3: Any selected 0- to 3-mc portion of the range between 200 cps and 15 mc.

SPA-3/25: Any selected 0- to 3-mc portion of the range between 200 cps and 25 mc.

b. CRT Screen Calibrations.

(1) Amplitude Calibrations.

The screen has a linear amplitude calibration on the right side of the scale (1.0 to 0 in divisions of 0.1) and a logarithmic amplitude calibration on the left side of the scale (0 DB to 40 DB in 5-db divisions). When the front-panel switch AMPLITUDE SCALE is set to LOG, the logarithmic calibrations are used. When this switch is set to the LIN or PWR position, the linear calibrations are used. The linear

---

\* Mounted on the rear apron of the analyzer-section chassis.

\*\* Mounted on the rear apron of the Model PS-19 chassis.

calibrations are indicated by horizontal lines, the logarithmic calibrations by dots. (If so ordered, a calibrated screen can be supplied with horizontal lines for the logarithmic calibrations and dots for the linear calibrations.)

(2) Frequency Calibrations.

The screen has a linear frequency calibration scale, each division corresponding to one-tenth of the sweep width selected with the SWEEP WIDTH dial. This scale, called SWEEP WIDTH FACTOR, is calibrated from +0.5 to -0.5 in 0.1 divisions.

c. CENTER FREQUENCY Dial Calibrations.

The CENTER FREQUENCY dial of the Model SPA-3 is calibrated from 0 to 13.5 MC in 0.5-mc divisions. The CENTER FREQUENCY dial of the Model SPA-3/25 is calibrated from 0 to 23.5 MC in two bands. The calibrations are 0.5-mc apart. The Center Frequency Vernier is not calibrated.

d. SWEEP WIDTH Dial Calibrations.

The SWEEP WIDTH dial is calibrated from 0 to 3 mc.

e. Input Amplitude Range.

By appropriate selection of controls, full scale LIN (ie, AMPLITUDE SCALE set to LIN) deflection can be obtained for input voltages between 20 microvolts and 2 volts. Full scale LOG (ie, AMPLITUDE SCALE set to LOG) can be obtained for input voltages between 200 microvolts and 2 volts.

f. Relative Voltage Accuracy.

$\pm 10\%$  throughout the frequency range (200 cps to 15 mc or 25 mc) on the LIN amplitude scale.

$\pm 1$  db throughout the frequency range (200 cps to 15 mc or 25 mc) on the LOG amplitude scale.

$\pm 20\%$  throughout the frequency range (200 cps to 15 mc or 25 mc) on the PWR amplitude scale.



Residual harmonic products of a single frequency input of maximum allowable voltage on any input range are suppressed by at least 46 db. Maximum allowable voltages are given in III-4b(3).

g. Resolution.

Resolution is defined as the frequency separation of two signals of equal amplitude, the deflections of which intersect 50% down from their peak amplitudes. Figure I-2 includes resolution curves for various sweep rates as a function of sweep width.

h. Measurement of Unequal Amplitude Signals.

Figure I-3 indicates minimum frequency separations required to measure signals of various amplitude ratios at various scanning velocities (scanning velocity being the product of sweep rate times sweep width).

i. Sweep Rate.

The sweep rate is continuously variable from 1 cps to 60 cps with one control. The sweep may be either free running, or synchronized with the ac power line, or externally synchronized.

j. Input Impedance.

The input impedance is 72 ohms. (50-ohm input impedance available on special order.) High-impedance signal sources require the use of a special probe, Model PRB-1. See section VI-1.

k. Frequency Markers.

Internal crystal-controlled frequency markers of 500 kc and its harmonics are provided.

l. Power Supply.

The PS-19 is factory wired for operation from a 50-cps to 60-cps, 118-volt source. It is supplied with an external constant-voltage transformer in order to maintain adequate operating stability over a line variation from 95 to 130 volts. The standard transformer supplied is rated for 250 va at 60 cps. For a 50-cps and/or 230-volt line, a suitable substitute will be furnished. The constant-voltage transformer must be used at all times. It should not be used to supply accessory or additional equipments.

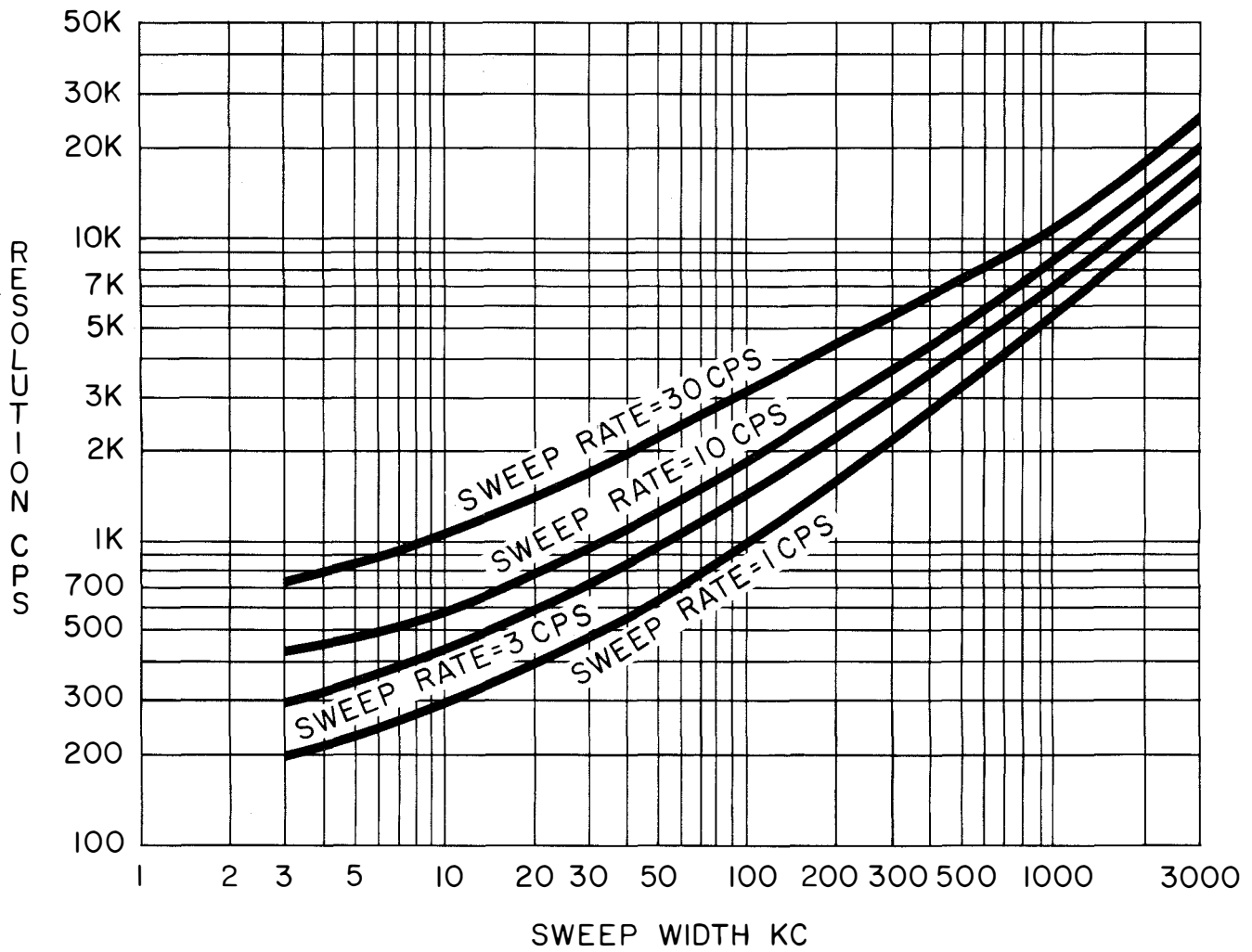

Figure I-2. Resolution Versus Sweep Width.

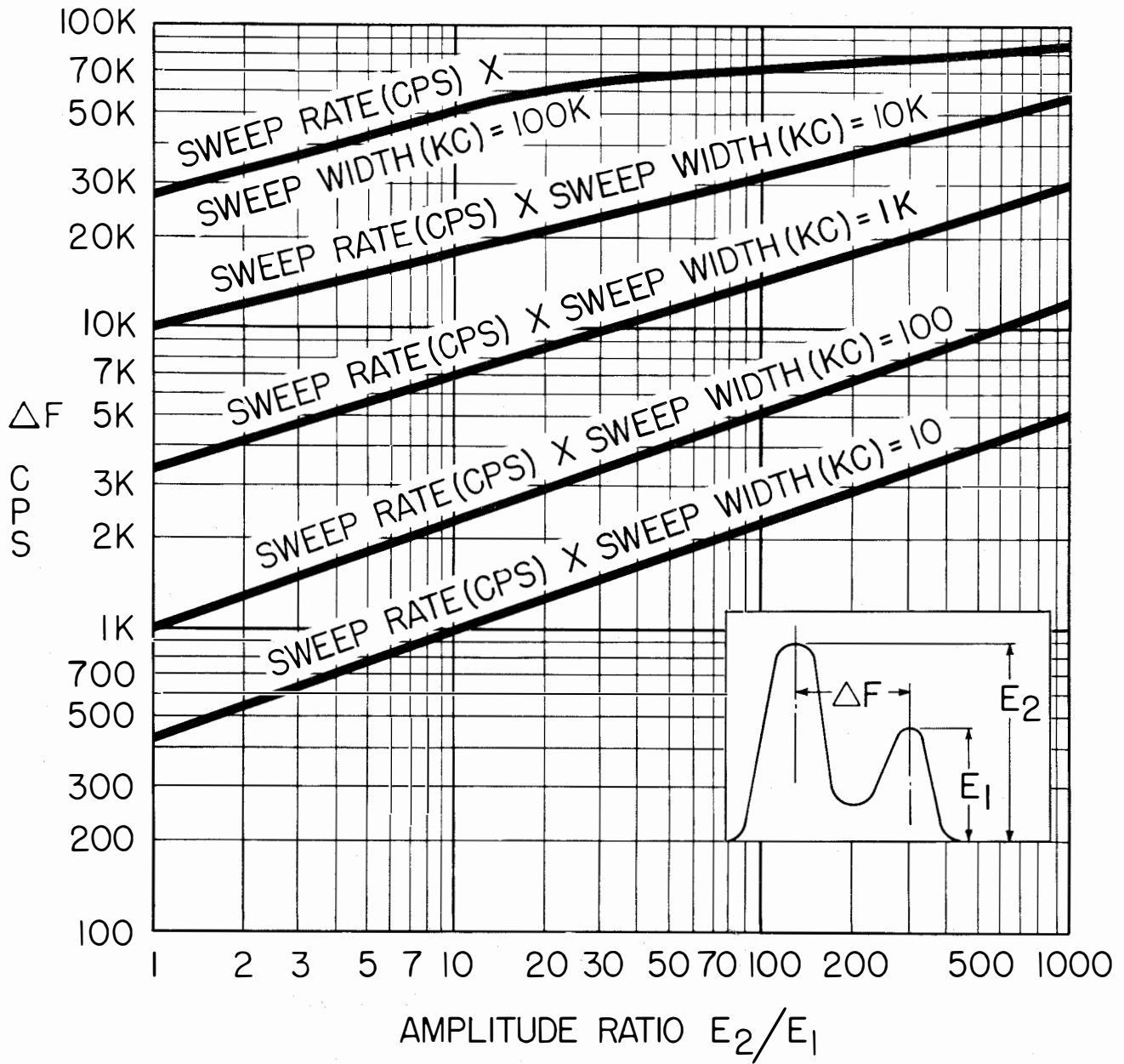

Figure I-3. Minimum Frequency Separation  $\Delta f$  Required to Measure Amplitude Ratios  $E_2/E_1$ .

I-6. PHYSICAL CHARACTERISTICS.

a. Weights.

| <u>Description</u>                                   | <u>Weight</u> |
|--|---------------|
| Analyzer Section -----                               | 33 lbs        |
| Model PS-19 -----                                    | 27 lbs        |
| Spectrum Analyzer (including PS-19) in cabinet ----- | 108 lbs       |
| Constant-Voltage Transformer -----                   | 24 lbs        |

b. Dimensions.

| <u>Description</u>                                 |                   |
|--|-------------------|
| Interconnecting cable, power, 14 wire, W3059 ----- | 25-1/2 in. c-to-c |
| Interconnecting cable, power, 5 wire, W3030 -----  | 8 ft. lg          |
| Line cord, ac, 3 wire, with adapter, W3033 -----   | 6 ft. lg          |

Dimensions of analyzer, power supply, and constant-voltage transformer are shown in Figures II-1, 2, 3, and 4.

The equipment is finished with a Munsell N-4.5 smooth gray enamel unless otherwise ordered.

I-7. TUBE COMPLEMENT.

a. Analyzer Section.

| <u>REFERENCE SYMBOL</u> | <u>TUBE TYPE</u> | <u>FUNCTION</u>             |
|-------------------------|------------------|-----------------------------|
| V101*                   | 6J4              | P/o Input Cascode Amplifier |
| V102*                   | 6J4              | P/o Input Cascode Amplifier |

---

\* Listed symbol, tube type, and function are for Model SPA-3.  
 V101 in the Model SPA-3/25 is an Input Cascode Amplifier (tube type 6BQ7A).  
 V102 in the Model SPA-3/25 is a Wide-Band Input Amplifier (tube type 6CB6).

| <u>REFERENCE SYMBOL</u> | <u>TUBE TYPE</u> | <u>FUNCTION</u>  |
|-------------------------|------------------|--|
| V103                    | 6J6              | Phase Splitter   |
| V104                    | 5879             | P/o Balanced Modulator   |
| V105                    | 5879             | P/o Balanced Modulator   |
| V106                    | 6AW8A            | A: 32-MC IF Amplifier<br>B: 29.3-MC Crystal Oscillator   |
| V107                    | 6BE6             | Mixer  |
| V108                    | 6AB4             | First Crystal-Filter Stage (2.7 MC)  |
| V109                    | 6AW8A            | A: First 2.7-MC Tuned IF Amplifier<br>B: Second Crystal-Filter Stage (2.7 MC)                    |
| V110                    | 6CB6             | Second 2.7-MC Tuned IF Amplifier   |
| V111                    | 6AU6             | Third 2.7-MC Tuned IF Amplifier  |
| V112                    | 12AU7            | A: Detector (LIN-LOG Amplitude Scale)<br>B: Audio Output Amplifier                               |
| V113                    | 12AT7            | A: Detector (PWR Amplitude Scale)<br>B: Amplifier for PWR Amplitude Scale                        |
| V114                    | 12AU7            | A: Vertical Amplifier<br>B: Vertical Phase Inverter and Amplifier                                |
| V115                    | 12AX7            | A: 500-KC-Marker Crystal Oscillator<br>B: Marker-Output Cathode Follower                         |
| V116                    | OA2              | Voltage Regulator for Sweeping-Oscillator Section  |
| V117                    | 12BY7            | Sawtooth Amplifier for Sweeping-Oscillator Section   |
| V118                    | 6BK7             | Sweeping Oscillator  |
| V119                    | 6J6              | A: Sweeping-Oscillator Output Amplifier<br>B: Sweeping-Oscillator Output Amplifier for Model G-6 |

| <u>REFERENCE SYMBOL</u> | <u>TUBE TYPE</u> | <u>FUNCTION</u>   |
|-------------------------|------------------|---|
| V120                    | 12AT7            | Sync Amplifier  |
| V121                    | 6U8              | A: Sawtooth Generator<br>B: Sawtooth-Output Cathode Follower          |
| V122                    | 12AU7            | A: Horizontal Amplifier<br>B: Horizontal Phase Inverter and Amplifier |
| V123                    | 5ADP7            | Visual Indicator (CRT)  |

b. Power -Supply Section (PS-19).

| <u>REFERENCE SYMBOL</u> | <u>TUBE TYPE</u>               | <u>FUNCTION</u>                    |
|-------------------------|--------------------------------|------------------------------------|
| V1                      | 5U4                            | Full-Wave Rectifier (B+ Supply)    |
| V2                      | 6146                           | P/o Series Regulator (B+ Supply)   |
| V3                      | 6146                           | P/o Series Regulator (B+ Supply)   |
| V4                      | 12AX7                          | Regulator Control Tube (B+ Supply) |
| V5                      | 12AX7                          | Regulator Control Tube (B+ Supply) |
| V6                      | 5651 or<br>Amperex<br>OG3/85A2 | Regulator-Control Voltage Standard |
| V7                      | 5651 or<br>Amperex<br>OG3/85A2 | Voltage Regulator (B- Supply)      |

I-8. TERMS AND DEFINITIONS.

a. Panoramic Reception is the simultaneous visual reception of one or several frequency sources whose frequencies are distributed over a continuous portion of the frequency spectrum. This definition distinguishes panoramic reception from the conventional reception which can be called "uni-signal" reception and which can be either aural, or visual, or both.

The main distinction between panoramic and uni-signal reception is the following: Panoramic reception is periodic reception over a wide range of the

spectrum. Each signal is received at fixed, rapid intervals, for a short period of time. At higher sweep rates, these signals are received so rapidly as to appear to be continuous on the crt screen because of the persistence of the screen material and retentivity of vision. Uni-signal reception is continuous reception, of the one signal at a time, over a very narrow range of the spectrum.

b. Sweep width is the band, measured in cycles, kilocycles or megacycles, which can be observed by Panoramic Reception and which corresponds to the range of oscillator sweep in the Panoramic equipment.

c. Frequency Sweep Axis is the horizontal line along which the signal deflections are produced and which can be calibrated in frequency according to a given frequency scale. The frequency scale used is a multiplication factor of the SWEEP WIDTH dial setting (SWEEP WIDTH FACTOR calibrated from -0.5 to +0.5 in divisions of 0.1).

d. Center Frequency is the frequency of the signal received on that part of the frequency sweep axis corresponding to zero sweep width.

e. Resolution is defined as the frequency difference between two signals of equal deflection amplitude, the pips of which intersect 50% down from their peak value. This characteristic corresponds to selectivity in ordinary receivers. The smaller this frequency difference, the better is the resolution.

f. Sweep Frequency (sweep rate) is the number of times per second the electron beam sweeps across the cathode-ray tube.

g. Deflection amplitude is the visual equivalent of signal input voltage. It is the height of a given signal deflection measured from the baseline to the top of the deflection.

h. Scanning Velocity is defined as the frequency band scanned by the equipment per unit time. When the frequency spectrum is scanned linearly, scanning velocity is the product of the sweep rate and the sweep width.

$$\begin{aligned}\text{Scanning Velocity} &= \text{Sweep Rate (sweeps/sec)} \times \text{Sweep Width (cycles/sec/sweep)} \\ &= \text{cycles/sec}^2\end{aligned}$$

Figure I-4. Front Panel, Model SPA-3 Analyzer Section.

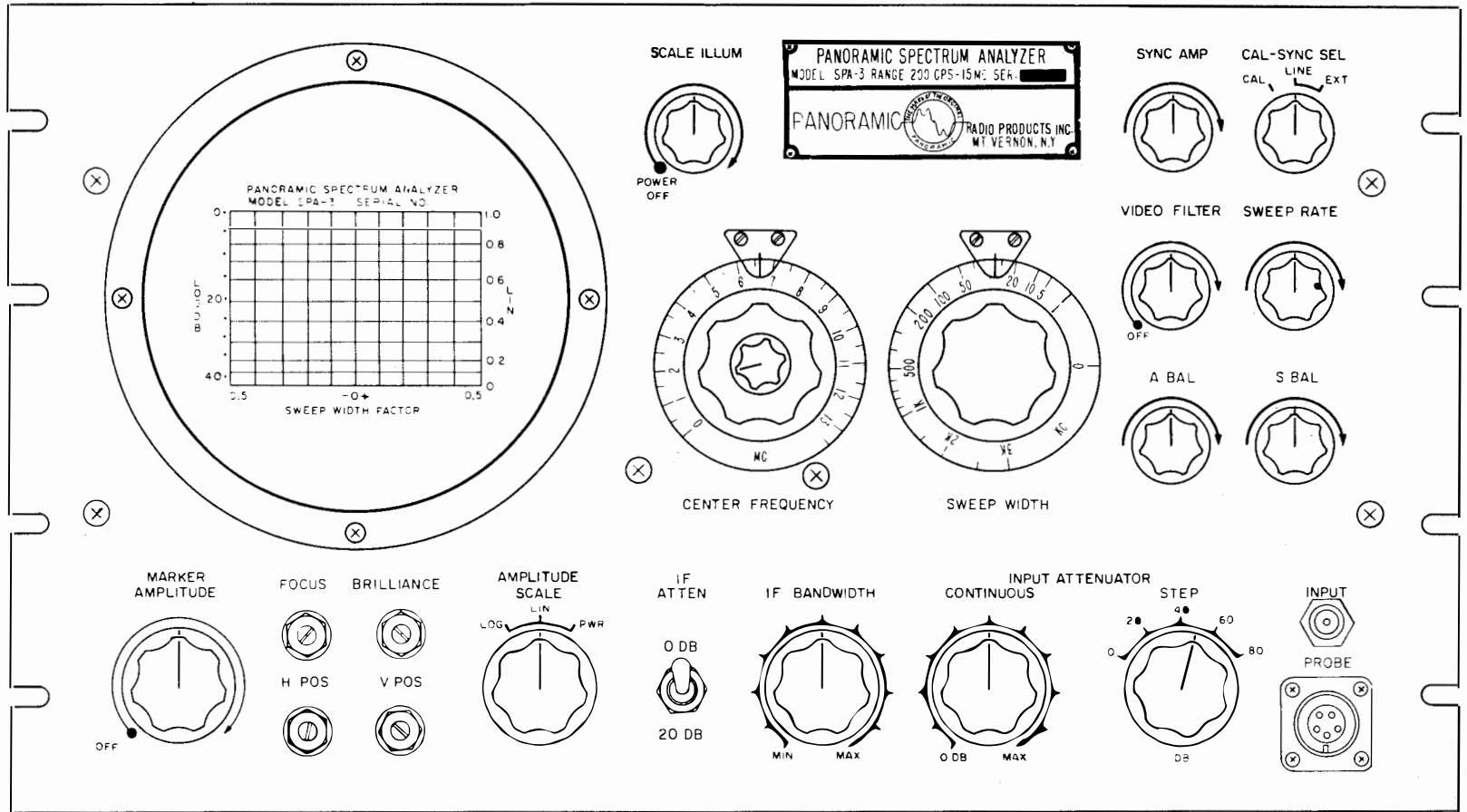
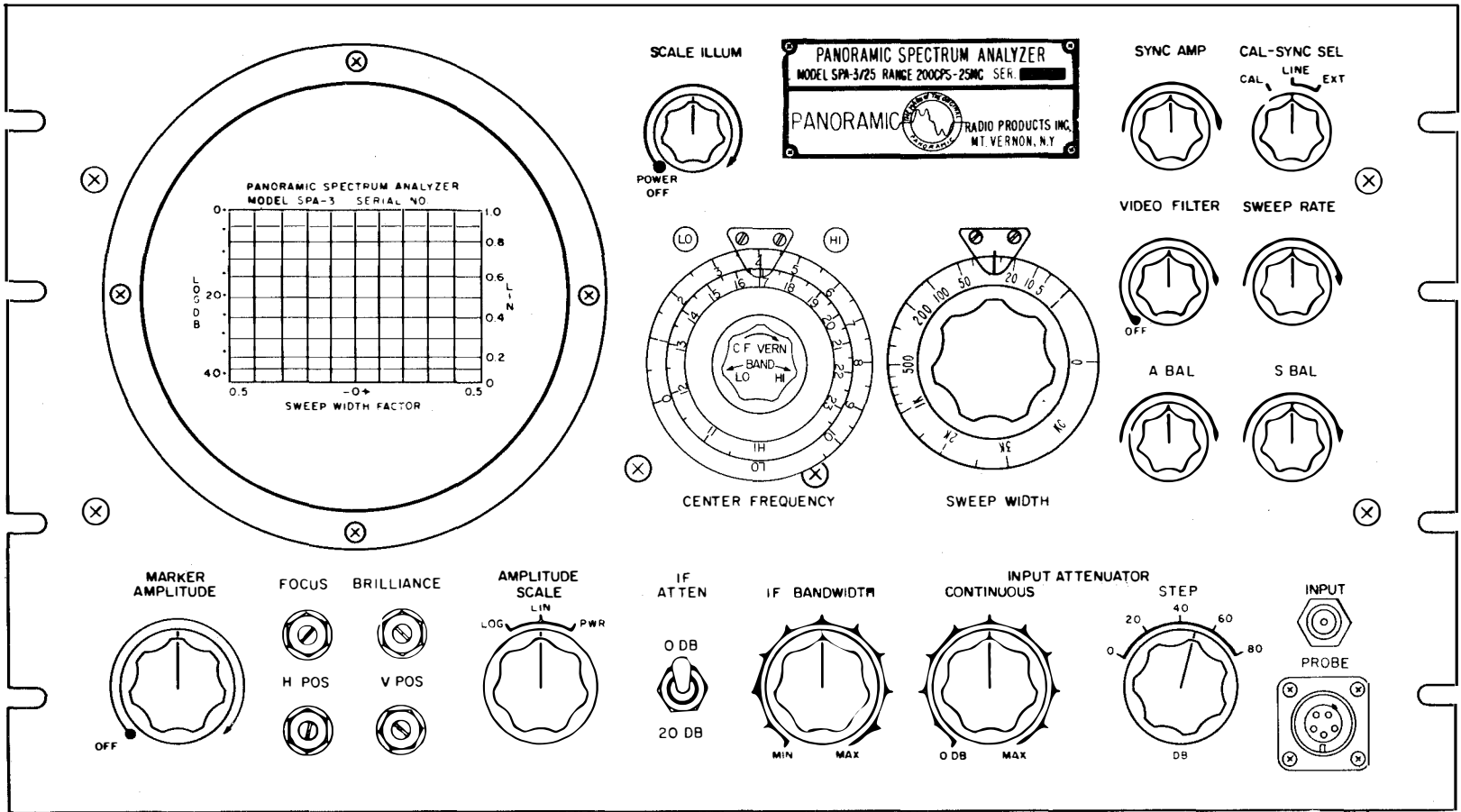



Figure I-5. Front Panel, Model SPA-3/25 Analyzer Section.



POWER SUPPLY UNIT  
MODEL PS-19 SER. NO. [REDACTED]  
118V 50-60 Hz 180W  
PART OF EQUIPMENT SER. NO. [REDACTED]

PANORAMIC RADIO PRODUCTS INC.  
MT. VERNON, N.Y.

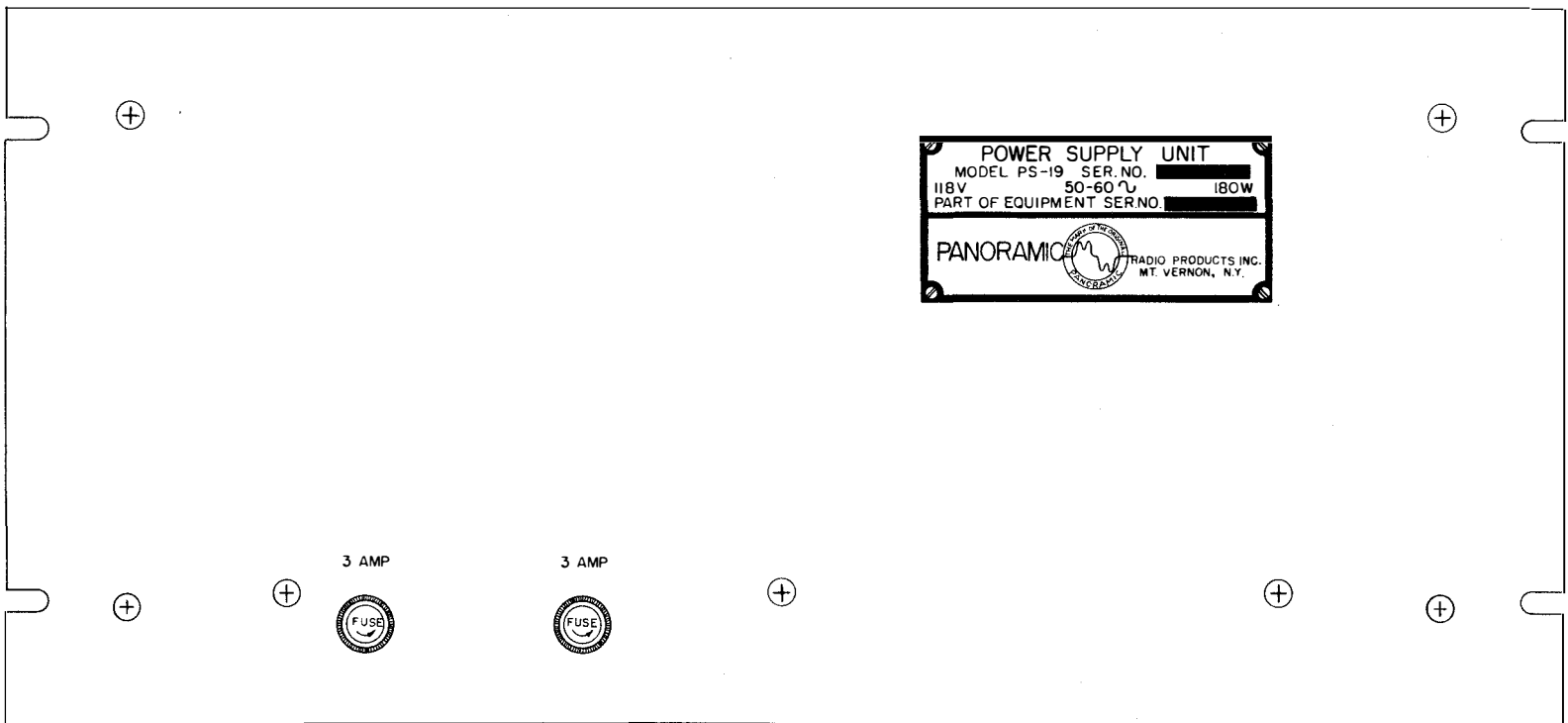

Figure I-6. Front Panel, Model PS-19.

## CHAPTER II INSTALLATION

### II-1. UNPACKING AND INITIAL INSPECTION.

This instrument has been tested and calibrated before shipment. Only minor preparations are required to put the instrument in operation.

If damage to the case is evident when delivery is made, have the person making the delivery describe the damage and sign the notation on all copies of the delivery receipt.

Most public carriers do not recognize claims for concealed damage if such damage is not reported within fifteen days after delivery. All shipping containers should be opened and the equipment inspected before fifteen days elapse.

If damage is found when the equipment is delivered, whether concealed or obvious, call or write the carrier and ask that an inspection be made by their agent. Although the carrier is liable for any damage in the shipment, Panoramic Radio Products, Inc. will assist in describing and providing for repair or replacement of damaged items.

Be careful in unpacking and handling the equipment to avoid damage or undue exposure to the elements. Check the contents against the packing list and Chapter I, Section 4 to avoid loss of parts in the packing material.

The equipment is shipped with all its tubes and crystals already installed. Check that tubes, crystals, and other "pluck-out" components are well seated.

### II-2. MOUNTING.

The equipment (Model SPA-3 or SPA-3/25 with power supply) is normally supplied mounted in a common carrying case. The constant-voltage transformer is supplied separately. The equipment if removed from its carrying case can be mounted in a standard, 19-inch, electrical-equipment rack.

The equipment should be located for effective ventilation, in an area where the ambient light is not excessively bright. Locate the constant-voltage transformer for effective ventilation and as far from the analyzer unit as possible in order to minimize hum pickup. Areas with a high level of electrical disturbance should be avoided. A convenient source of suitable ac power (see section II-3) is required.

See figures II-1 to II-4 for outline dimensional drawings of the various units.

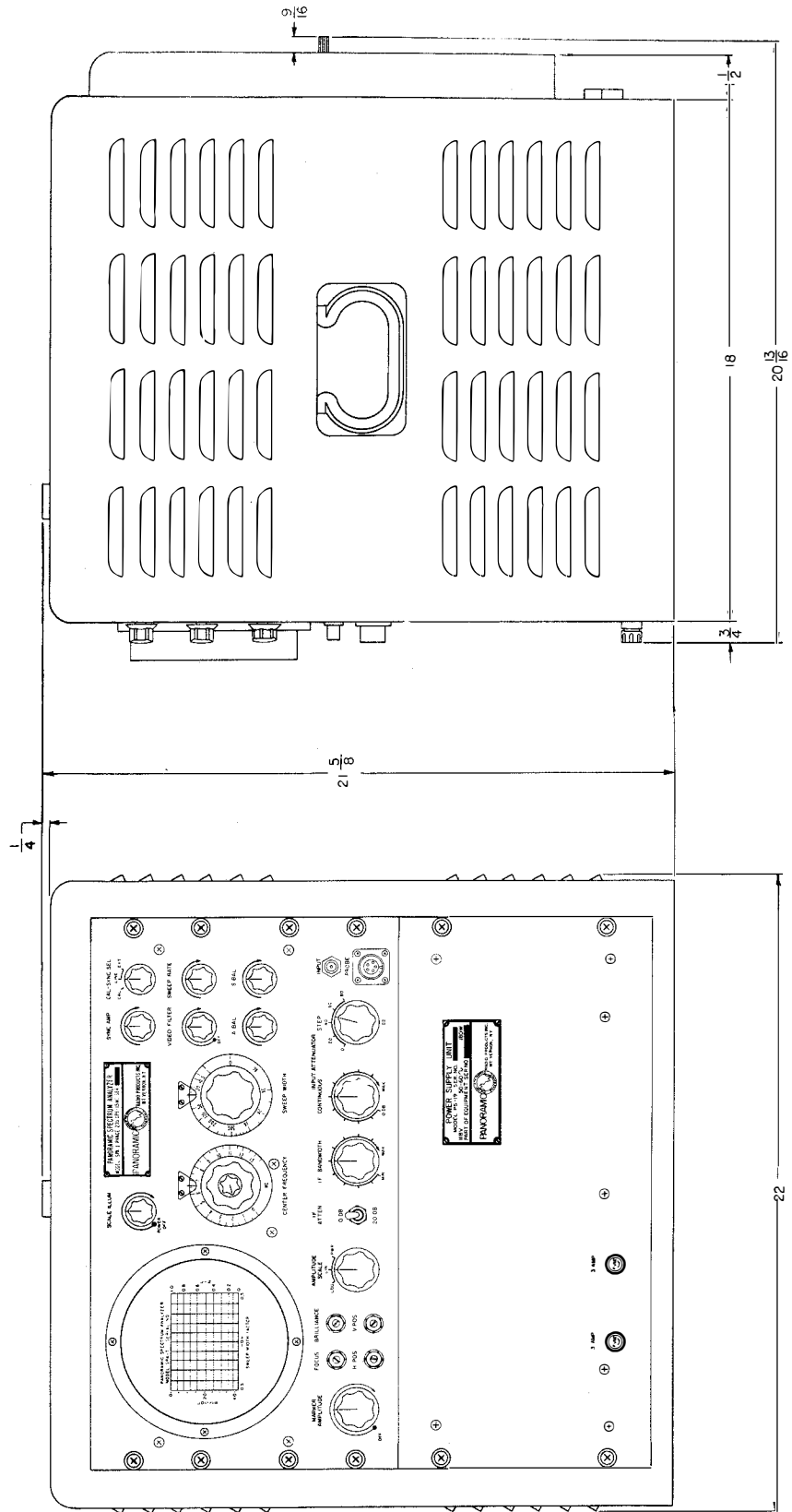

Figure II-1. Outline Dimensional Drawing, Models SPA-3 and SPA-3/25 (Including Model PS-19). Cabinet-Mounted Style.



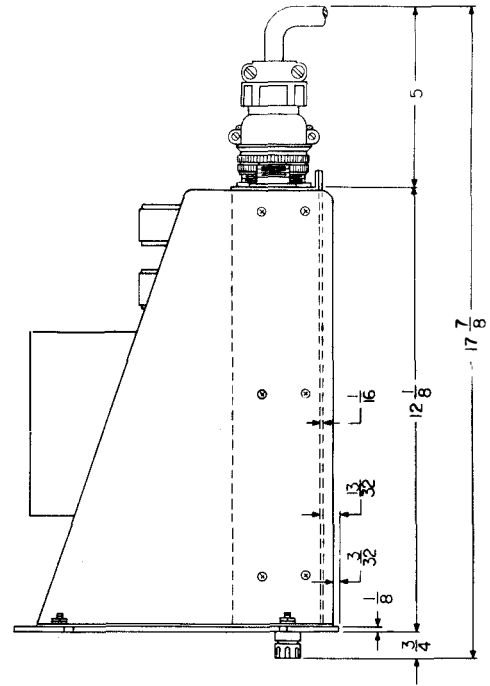
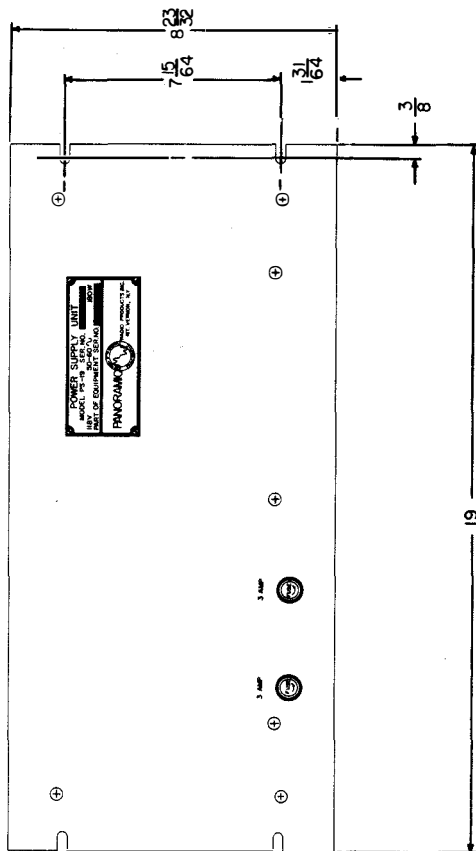
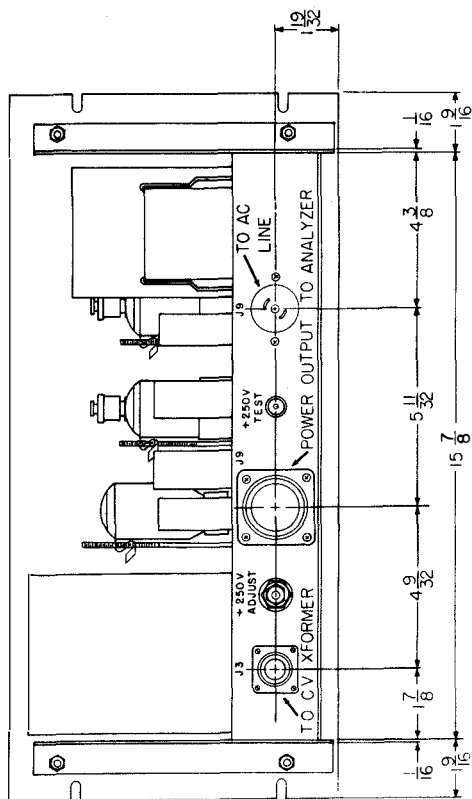

Figure II-3. Outline Dimensional Drawing. Model PS-19. Rack-Mounted Style.

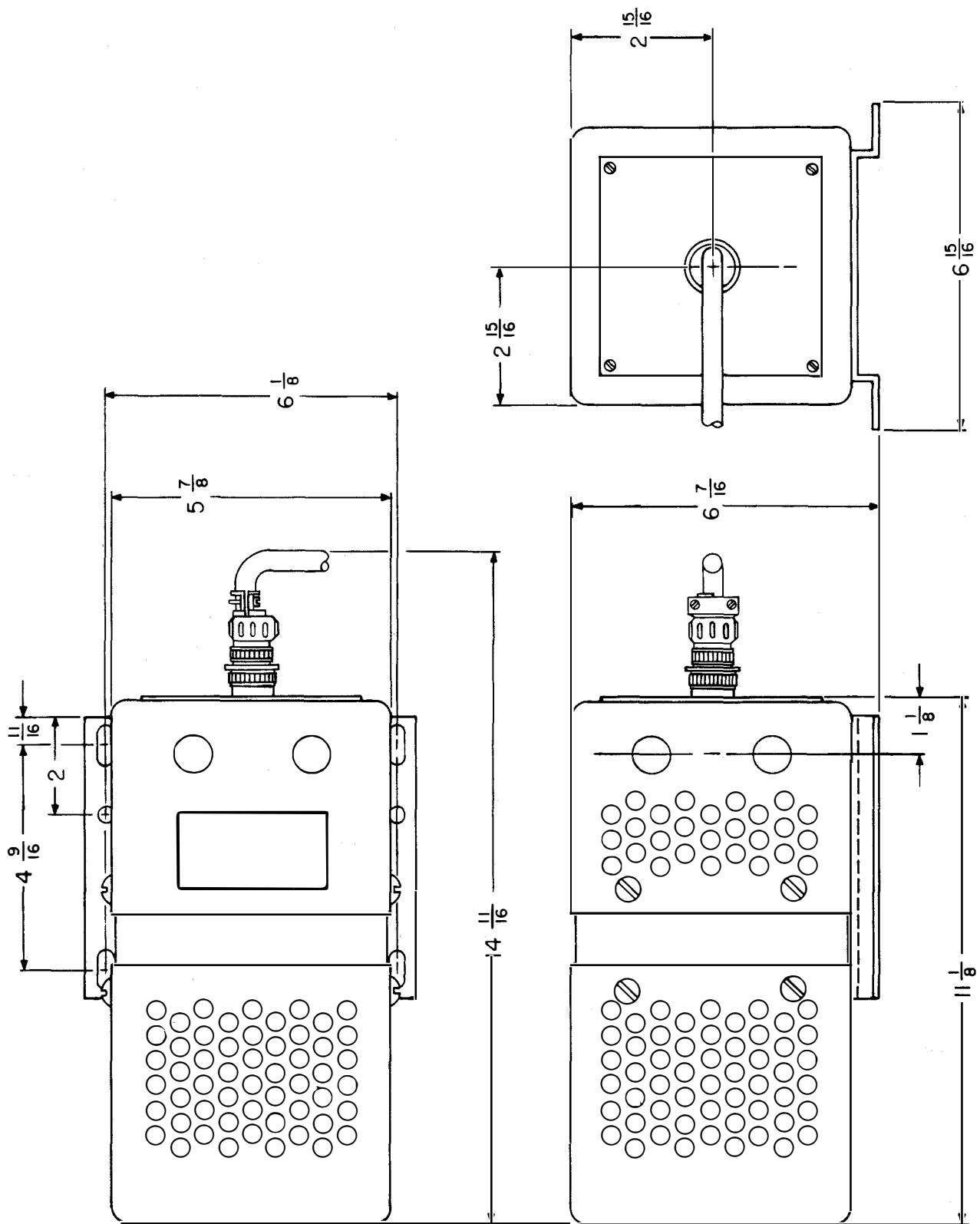

Figure II-4. Outline Dimensional Drawing.  
Constant-Voltage Transformer.

### II-3. INTERCONNECTING PROCEDURE.

a. The power supply of the Panoramic Spectrum Analyzer is factory wired for 118-volt, 50- to 60-cycle operation. In order to deliver a stable supply of this power requirement, a constant-voltage transformer is supplied.\* This transformer must be considered an integral part of the Panoramic equipment and must be used at all times. Do not, however, use it to supply power to auxiliary or additional equipments. For satisfactory operation of the Panoramic equipment, the constant-voltage transformer must be used only within the input voltage range and only at the frequency specified on its nameplate. Normally, a 95- to 130-v, 60-cps constant-voltage transformer is supplied. The following voltage-frequency combinations can be supplied if specified on the purchase order.

| <u>Input Voltage</u> | <u>Frequency</u> | <u>Output Voltage</u> |
|----------------------|------------------|-----------------------|
| 95 - 130 v           | 50 cps           | 118                   |
| 190 - 260 v          | 60 cps           | 118                   |
| 190 - 260 v          | 50 cps           | 118                   |

b. The equipment normally is shipped with the interconnecting cable between the analyzer unit and power supply already installed. Be sure that all plugs are well seated. If the equipment is supplied less cabinet (ie, for rack mounting), the 14-wire interconnecting cable must be connected between the 14-contact male receptacle on the rear apron of the analyzer-section chassis and the 14-contact female receptacle on the rear apron of the power-supply chassis.

c. Connect the constant-voltage transformer to the power supply, using the supplied five-wire cable.\*\* The appropriate five-contact male receptacle is located on the rear apron of the power-supply chassis.

---

\* If so ordered, the equipment is supplied less constant-voltage transformer and modified for operation from a well-regulated  $\pm 1\%$ , 118-v, 50- to 60-cps power line. The power line must provide the same waveform as does the constant-voltage transformer or, if the power line provides a distortion-free voltage, the power supply is appropriately modified at the factory.

\*\* If the equipment is modified for operation without the constant-voltage transformer (see footnote, section II-3a), it is only necessary to connect the 3-wire line cord. Be sure the center pin of the 3-wire cord is grounded.



Connect the three-contact, twistlock receptacle on the rear apron of the power-supply chassis to the ac power line using the supplied three-wire, ac line cord.

**CAUTION:** Be sure that the power line is appropriate for the constant-voltage transformer being used both as to voltage and frequency. Refer to the constant-voltage-transformer nameplate for input requirements.

If the power source does not accommodate the three-wire cord (center pin grounded) then the supplied adapter should be used. If the adapter is used, the ground wire of the adapter must be connected to a suitable external ground.

d. Signal input from a 72\*-ohm source is connected to the front panel INPUT receptacle, through a suitable input cable. This input cable should be fabricated from RG-59/U coaxial cable and be terminated at one end with a type BNC plug to match the INPUT receptacle. The other end should be terminated suitable to the signal source.

To insure flatness of response, if the output impedance of the source is low but other than 72\* ohms, a suitable matching pad should be inserted between the signal source and the input cable on the Model PRB-1 probe (supplied only if ordered) should be used. See section VI-1 for information relating to the probe.

To connect signals from a high-impedance source, the Model PRB-1 probe should be used.

#### II-4. INSTALLATION ADJUSTMENTS AND CHECKS.

**NOTE:** If the adjustments given in this section fail to give the indicated results, Chapter V of the Instruction Manual should be referred to for appropriate maintenance action. Refer to Chapter III for details concerning operating techniques.

a. Set the following front-panel controls as listed.

---

\* 50, if the spectrum analyzer is supplied with 50-ohm input impedance.

|                                    |                             |
|------------------------------------|-----------------------------|
| CENTER FREQUENCY Dial -----        | 10 MC                       |
| SWEEP WIDTH Dial -----             | 3 MC                        |
| AMPLITUDE SCALE -----              | LOG                         |
| IF ATTENUATOR -----                | 20 DB                       |
| INPUT ATTENUATOR, STEP -----       | 80 DB                       |
| INPUT ATTENUATOR, CONTINUOUS ----- | MAX                         |
| IF BANDWIDTH -----                 | MAX                         |
| VIDEO FILTER -----                 | OFF                         |
| MARKER AMPLITUDE -----             | OFF                         |
| CAL-SYNC SEL -----                 | LINE                        |
| SYNC AMPL -----                    | Completely counterclockwise |

Be sure that the shorting plug is securely seated in the ACCESSORY EQUIPMENT receptacle at the rear of the analyzer chassis.

b. Switch on the equipment by rotating the SCALE ILLUM control fully clockwise. The crt screen edge lighting should go on immediately.

Within 30 seconds, a dot should appear on the screen and within a few seconds start to sweep across the screen. This moving dot is the baseline trace. If nothing appears on the screen turn the BRILLIANCE control clockwise with a screwdriver.

CAUTION: If a stationary dot appears on the screen, turn the power off and refer to Chapter V for appropriate action.

c. The baseline trace should coincide with the baseline of the calibrated screen. If there is a lack of parallelism, it is necessary to rotate the cathode ray tube.

WARNING: Be careful of the high-voltage leads of the crt.

This can be done after loosening one of the two screws holding the crt socket clamp. When parallelism has been obtained, be sure that the crt is fully forward before retightening the screws.

If the baseline trace does not coincide with the baseline of the calibrated screen, a suitable adjustment of the V POS control should be made.

The baseline trace should extend at least 1/8 inch beyond the calibrated portion of the crt screen at all sweep rates and not extend past the edges of the crt screen at least at one sweep rate. See "e" below for the technique of setting sweep rate and obtaining sweep synchronization.

d. FOCUS, BRILLIANCE, and ASTIGMATISM (located on analyzer-section chassis) are adjusted as required for a suitable trace. FOCUS and ASTIGMATISM should be set for a clear, sharp, uniform trace. BRILLIANCE should be set at the minimum point of suitable visibility. Do not use the BRILLIANCE control to compete with external light falling on the crt screen but rather reduce the external light or shield the screen.

e. Rotate SWEEP RATE control throughout its range noting that clockwise rotation increases the rate.

Turn CAL-SYNC SEL to CAL. The baseline will become a series of sine waves, the number of which indicates the sweep rate. The sweep rate is determined by counting the number of cycles on the screen and dividing this number into 60.\* (Eg, if there are 2 cycles on the screen, the sweep rate =  $60/2 = 30$  cps.) To synchronize the sweep to the power line, adjust the SWEEP RATE control such that the appropriate number of cycles appear on the screen and are almost stationary with a slight drift to the left. Then rotate the SYNC AMPL control clockwise until the cycles become stationary. If the baseline becomes too short, excessive sync (control too far clockwise) is being provided. Minimum sync amplitude consistent with good synchronism is the best setting. Note that at low sweep rate, it is easier to count sweeps, using a stop watch for timing, than to count cycles.

Set SWEEP RATE and SYNC AMPL for a stable 30-cps rate (2 cycles on the screen). Return the CAL-SYNC SEL to the LINE position.

---

\* 50 if the power-line frequency is 50 cps.

f. Turn the CENTER FREQUENCY dial to 0. With the Model SPA-3/25, be sure that the Center Frequency VERNier is set for the LO band. This is done by turning the control to the extreme counterclockwise position until the switch is actuated. A rise or deflection of the baseline around the center of the screen may or may not be present. The presence of this pip indicates an unbalanced condition in the balanced modulator. Manipulate the A BAL and S BAL controls alternately to minimize this deflection. Set the IF ATTEN to 0 DB and rebalance. With change of setting of the IF ATTEN from 20 DB to 0 DB the balance controls should become more critical, indicating increased sensitivity of the intermediate-frequency section. It may not be possible to completely eliminate the deflection, in which case proper balance is indicated by the presence of a minimum amplitude double hump that resembles an "m".

g. Change control settings as follows:

|                                    |       |
|------------------------------------|-------|
| CENTER FREQUENCY -----             | 10 MC |
| IF ATTEN -----                     | 0 DB  |
| INPUT ATTENUATOR, STEP -----       | 80 DB |
| INPUT ATTENUATOR, CONTINUOUS ----- | 0 DB  |
| AMPLITUDE SCALE -----              | LIN   |

Switch the internal markers on by rotating the MARKER AMPLITUDE control clockwise. Adjust the control for a convenient height of marker presentation. The 10-mc marker pip should be at or near the center of the screen. Gradually reduce SWEEP WIDTH to minimum, maintaining the 10-mc pip at the center of the screen with the CENTER FREQUENCY control. Return to 3-mc sweep width and adjust H POS until the top of the pip coincides with the center vertical line (0 frequency calibration) on the screen. With the SWEEP WIDTH dial set for 3 mc and the CENTER FREQUENCY dial set for 10 mc, the 11.5-mc marker pip should fall within  $\pm 1/2$  division of the -0.5 calibration mark. Note that the marker pips are 0.5-mc apart.

h. Check the IF BANDWIDTH control by reducing the sweep width until the base of a centered, half-scale, 10-mc marker pip occupies approximately one-third of the screen width. Then slowly turn IF BANDWIDTH counterclockwise. The pip width should decrease. At the same time there may be a change in pip height. Maintain a half-scale pip by adjusting the MARKER amplitude control. As IF BANDWIDTH is turned counterclockwise small convolutions of "ringing" will appear on the trailing edge of the pip. Optimum resolution occurs when the first convolution beyond the apex of the pip dips into the baseline. Section III-4c contains a more extended discussion of the variation of screen presentation with change in IF BANDWIDTH setting.

i. Using the marker pips, check the SWEEP WIDTH dial calibrations corresponding to frequencies above 0.5 mc. Set the SWEEP WIDTH to 3 mc and CENTER FREQUENCY to 1.5 mc. Turn MARKER AMPLITUDE on and set it for a convenient amplitude of marker display. The zero-frequency pip should be at or near the -0.5 calibration mark of the SWEEP WIDTH FACTOR screen scale. (It may be necessary to adjust A BAL and/or S BAL to unbalance the equipment sufficiently to see the zero-frequency pip.) The sixth marker pip to the right of the zero-frequency pip should be at or near the +0.5 mark of the SWEEP WIDTH FACTOR scale. (Each pip being 0.5-mc apart, the sixth pip to the right of the zero-frequency pip corresponds to a frequency of 3 mc. Since SWEEP WIDTH is set for 3 mc, a 3-mc pip should fall at +0.5 when the zero-frequency pip falls at -0.5 on the SWEEP WIDTH FACTOR scale.) Note that it may be necessary to adjust CENTER FREQUENCY to center this display of six marker pips plus the zero-frequency pip. Other SWEEP WIDTH dial calibration in increments of 0.5 mc between 0.5 mc and 3 mc can be checked using the 500-kc-apart marker pips. For example, setting the CENTER FREQUENCY dial for 1.75 mc and the SWEEP WIDTH dial for 0.5 mc, marker pips should appear at +0.5 and -0.5 on the SWEEP WIDTH FACTOR scale (approximately).

To check sweep widths narrower than 0.5 mc, an amplitude-modulated signal may be used. The modulating source should be set to a frequency equal to one-half the SWEEP WIDTH dial setting. The CENTER FREQUENCY dial should be set to the carrier frequency. The upper and lower side bands may then be used to determine the actual sweep width. Note that in order to have suitable pips at narrow sweep widths it may be necessary to reduce the sweep rate and the if bandwidth thereby improving resolution. Section III-4d contains a more extended discussion of narrow-band techniques.

j. Check the CENTER FREQUENCY dial by setting the SWEEP WIDTH dial to 3 mc and then matching the CENTER FREQUENCY dial calibrations with the corresponding marker frequency (starting with the CENTER FREQUENCY dial set to 0). The top of the pip should appear at or near the center of the screen. Be sure that the Center Frequency VERNIER is set such that the zero-frequency pip is at the center of the screen when CENTER FREQUENCY is set to 0.

k. Check the amplitude scales using a signal of variable and known amplitude and low distortion. The voltages given in these checks are approximate since the instrument measures relative amplitude rather than absolute amplitude. Any convenient fixed CENTER FREQUENCY and SWEEP WIDTH settings compatible with the generator frequency and pip readability may be used. Set the controls as follows:

AMPLITUDE SCALE ----- LIN  
 IF ATTEN ----- 0 DB  
 INPUT ATTENUATOR, CONTINUOUS ----- Completely counterclockwise  
 INPUT ATTENUATOR, STEP ----- 0 DB  
 IF BANDWIDTH ----- MAX  
 VIDEO FILTER ----- OFF  
 SWEEP RATE ----- 30 cps

A signal input amplitude of approximately 20 microvolts should result in a full-scale pip. Adjust generator level if necessary for a full-scale pip. Change the INPUT ATTENUATOR, STEP to 20 DB. The signal input amplitude required for full-scale deflection should be approximately 200 microvolts. Change IF ATTEN to 20 DB and INPUT ATTENUATOR, STEP to 0 DB. The pip should remain full scale. Set IF ATTEN to 0 DB and INPUT ATTENUATOR, STEP to 40 DB, 60 DB, and then 80 DB. The signal input amplitude required for full-scale deflection should be approximately 2 millivolts, 20 millivolts, and 200 millivolts respectively. With IF ATTEN at 20 DB and INPUT ATTENUATOR, STEP at 80 DB, an approximately 2-volt input should result in a full-scale deflection. Return INPUT ATTENUATOR, STEP to 40 DB and IF ATTEN to 0 DB. Reduce input amplitude to approximately 2 millivolts to obtain a full-scale pip. Increase input amplitude to 20 millivolts and rotate INPUT ATTENUATOR, CONTINUOUS completely clockwise. The pip should be less than full scale, indicating more than a 20-db range in this control. Return INPUT ATTENUATOR, CONTINUOUS to the full counterclockwise position and adjust the input amplitude for a full-scale pip.

Switch AMPLITUDE SCALE to LOG. The pip amplitude should be in line with the 20 DB calibration dot on the left side of the calibrated crt scale. Change INPUT ATTENUATOR, STEP to 20 DB. Pip amplitude will again increase to full scale. Intermediate amplitude calibration points on the crt screen for both the LIN and LOG positions of AMPLITUDE SCALE may be checked against known input levels.

Switch AMPLITUDE SCALE to PWR. Using INPUT ATTENUATOR, STEP and CONTINUOUS, obtain a full-scale pip. Decrease the input amplitude of the signal in 0.1 steps of power. The pip amplitude should decrease approximately one linear division of the crt screen for each 0.1 of reduction of input power. (The voltage required for 0.1-scale deflection is approximately one-third that required for full-scale deflection.)

20 X10<sup>-6</sup>      20 X10<sup>-6</sup>

## CHAPTER III OPERATING INSTRUCTIONS

Haphazard operation or improper setting of controls can cause damage to the equipment and/or false or misleading results. Satisfactory results will be obtained if the equipment is operated carefully in accordance with the instructions found in this chapter.

For convenience, this chapter is divided into four sections.

Sections 1 and 2 describe the function of the operating and semi-adjustable operating controls. The controls listed in these two sections are the only controls required in operation. All other controls are used only in maintenance or service of the units. Such controls should not be adjusted by operating personnel but should be left to experienced service personnel and should be adjusted only in accordance with the procedures given in Chapter V.

Preliminary adjustments for operation are given in Section 3. For best results, the preliminary adjustments should be made with care and exactness each time the equipment is turned on.

The techniques of operation for various types of measurements are given in Section 4. The use of optional accessory equipment to extend the application of the equipment is discussed in Chapter VI. While it is not possible to cover all possible measurement problems, the general procedures can be adapted to specific problems. Our Applications Engineering Section is available for consultation and assistance when special or unusual measurement problems are encountered.

### III-1. OPERATING CONTROLS.

The following controls are available to the operator. They are mounted on the front panel.

a. SWEEP WIDTH.

This control is used to set the width of the segment of the spectrum to be analyzed. The control provides any sweep width from 0 to 3 mc. The sweep width is indicated on the associated calibrated dial.

b. CENTER FREQUENCY.

This control provides a continuously adjustable selection of the frequency which will appear under the 0 marker on the screen. In the SPA-3, the dial

associated with this control is calibrated from 0 to 13.5 MC. In the SPA-3/25, the associated dial is calibrated from 0 to 23.5 MC in two bands.

c. CENTER FREQUENCY VERNIER (and BAND SELECTOR for SPA-3/25).

This control (concentric with the CENTER FREQUENCY control) is used to set the calibration of the low frequency end of the CENTER FREQUENCY dial and as a vernier. On the SPA-3/25, this control also is used to select the frequency band.

d. AMPLITUDE SCALE (LOG-LIN-PWR).

This three-position switch is used to select a logarithmic voltage-amplitude scale, a linear voltage-amplitude scale, or a power-amplitude scale.

e. SWEEP RATE.

This control provides continuously adjustable sweep rates between 1 cps and 60 cps. Clockwise rotation increases the sweep rate.

f. CAL-SYNC SEL.

This switch has three positions: CAL, LINE, and EXT. In the CAL position, the sweep rate may be synchronized with the power-line frequency. The EXT position permits sweep synchronism by means of a suitable signal connected to the EXT SYNC receptacle (located on the rear apron of the analyzer chassis). Sweep without synchronism (free-running sweep) may be obtained in all three positions by setting SYNC AMP completely counterclockwise.

g. SYNC AMP.

The amplitude of the sweep-synchronizing signal is adjusted with this control to provide for proper crt beam sweep synchronism. Maximum amplitude occurs at the maximum clockwise position. A free-running sweep is obtained by setting the control completely counterclockwise.

h. IF BANDWIDTH.

The bandwidth of the intermediate-frequency section is adjusted with this control. Clockwise rotation increases the if bandwidth.



i. INPUT ATTENUATOR.

(1) STEP Control.

A rotation of this control clockwise gives a maximum 80 db attenuation of the input signal in 20-db steps.

(2) CONTINUOUS Control.

A full clockwise rotation of this control gives more than a 20-db attenuation of the input signal.

j. IF ATTEN.

For any given setting of the INPUT ATTENUATOR controls, this switch provides 20 db additional attenuation when switched from 0 DB to 20 DB. The 20 DB position should only be used when the AMPLITUDE SCALE is on LIN or PWR. When on LOG, the IF ATTEN must be set on 0 DB to avoid inadvertent overload.

k. MARKER AMPLITUDE.

The amplitude of the internal crystal-controlled frequency markers (consisting of 500 kc and its harmonics) is varied with this control. Maximum marker amplitude is provided in the maximum clockwise position of the control. The control has an OFF position to turn the markers off.

l. VIDEO FILTER.

This control provides continuous adjustment of a smoothing filter located at the output of the detector. Clockwise rotation increases the degree of filtering. The control has an OFF position which disconnects the filter.

When the equipment is being used to measure discrete signals, the control is used to reduce noise, beats between signals close in frequency, etc. When the equipment is being used to measure noise spectra, the control is used to obtain averaging of the noise spectrum envelope.

m. A BAL and S BAL.

These controls are used to suppress an internally generated deflection which may appear on the crt screen when the CENTER FREQUENCY dial is at or near 0.

n. SCALE ILLUM - POWER OFF.

Turning this control clockwise switches on the power to the equipment. The control is then used to adjust the intensity of edge lighting of the screen. The OFF position turns the power off.

III-2. SEMI-ADJUSTABLE OPERATING CONTROLS.

The screwdriver-adjustable controls listed in this section may be adjusted by the operator as required. Unless otherwise indicated, the controls are located on the analyzer-section front panel. The adjustment of all chassis components, other than those listed in this section, should be left to experienced maintenance personnel. Such maintenance controls should be adjusted only in accordance with the procedures of Chapter V.

a. FOCUS.

This control adjusts the sharpness of the trace.

b. BRILLIANCE.

This control is used to adjust the intensity of the trace. Clockwise rotation increases the intensity.

c. H POS.

This control is used to adjust the horizontal position of the trace on the screen. Clockwise rotation shifts the trace to the right.

d. V POS.

This control is used to adjust the vertical position of the trace on the screen. Clockwise rotation raises the trace.

e. ASTIG. (located on the analyzer-section chassis).

This control is used to provide uniform focus throughout the trace.

f. LINE SIZE (located on the analyzer-section chassis).

This control is used to obtain the proper line size. Clockwise rotation increases the line size.

### III-3. PRELIMINARY ADJUSTMENTS.

For best results, these preliminary adjustments should be made with care and exactness each time the equipment is turned on.

- a. Set the following front-panel controls to the listed position:

|                             |       |
|-----------------------------|-------|
| SWEEP WIDTH Dial -----      | 3 MC  |
| CENTER FREQUENCY Dial ----- | 10 MC |
| IF BANDWIDTH -----          | MAX   |
| AMPLITUDE SCALE -----       | LOG   |
| IF ATTEN -----              | 0 DB  |
| VIDEO FILTER -----          | OFF   |

Be sure that the shorting plug is securely plugged into the ACCESSORY EQUIPMENT receptacle at the rear of the analyzer chassis.

- b. Turn the power on by rotating SCALE ILLUM clockwise. The crt screen edge lighting should go on immediately. Within 30 seconds, a dot should appear on the screen and within a few seconds start to sweep across the screen.

If nothing appears on the screen, turn the BRILLIANCE control clockwise. The BRILLIANCE should be set at a minimum point of suitable visibility and the FOCUS control for the finest clear line. A later adjustment of FOCUS and BRILLIANCE may be required, since the appropriate settings are partially dependent upon the signal density. Do not use the BRILLIANCE control to compete with external light falling on the crt screen but rather reduce the external light or shield the screen.

When viewing the crt screen, the eye of the observer should be along the axis of the crt at a distance of approximately 15 inches from the face of the crt. The screen calibrations have been made from this position. Hence, any other position will introduce parallax error. See Figure III-1.

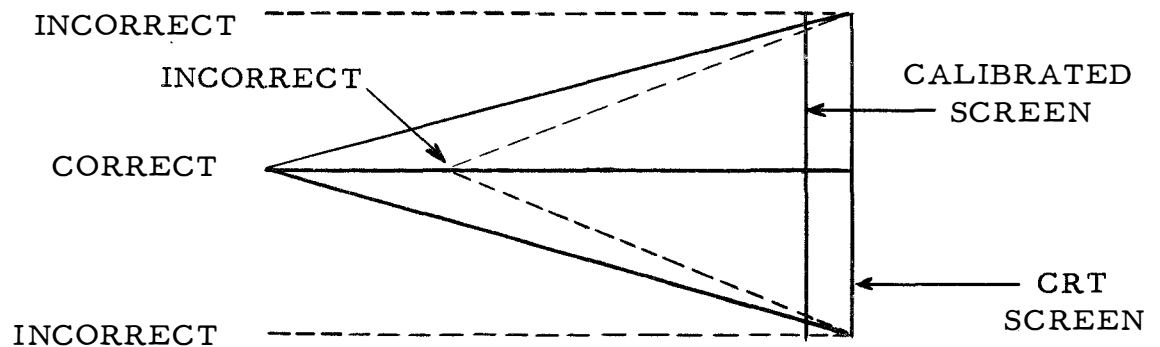

Figure III-1. Correct Viewing of CRT Screen.

If necessary, set V POS for coincidence of the baseline trace with the base of the calibrated crt scale.

For wide-band analysis, the instrument may be used within a few minutes although adjustment may be required as the instrument warms up. For narrow-band analysis, it is advisable to wait at least one-half hour to allow the unit to stabilize.

c. Set the CENTER FREQUENCY dial to 0 and adjust A BAL and/or S BAL so that the zero-frequency pip (see Figure III-2) is visible. With the Model SPA-3/25, be sure that the Center Frequency VERNier is set for LO Band. This is done by turning the control to the extreme counterclockwise position until the switch is actuated. Adjust the Center Frequency VERNier control (concentric with the CENTER FREQUENCY control) so that the zero-frequency pip is at the center of the screen. Then adjust A BAL and S BAL to minimize the zero-frequency pip.

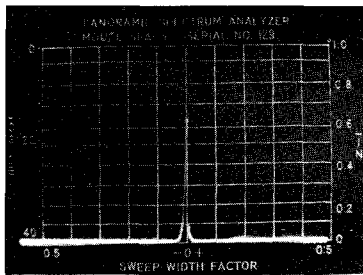

Figure III-2. Zero-Frequency Pip.

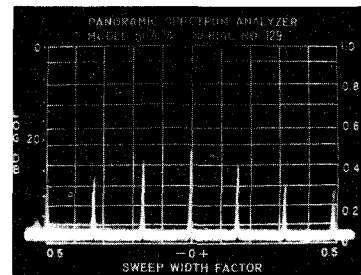

Figure III-3. Marker Presentation.  
3-Mc Sweep Width  
10-Mc Center Frequency.

d. Set the CENTER FREQUENCY dial to 10 MC. Turn MARKER AMPLITUDE on and adjust it for a convenient height of marker presentation. The 10-mc marker pip should be at or near the center of the screen. Gradually reduce the SWEEP WIDTH to minimum, maintaining the 10-mc pip at the center of the screen with the CENTER FREQUENCY control. Return to 3-mc sweep width and adjust H POS until the top of the pip coincides with the center vertical line.

e. If desired, applicable installation checks (Section II-4) can be made. From this point, all control settings are dependent upon the input signal characteristics and the type of measurements to be made.

### III-4. OPERATING TECHNIQUES.

Once the preliminary adjustments have been made, the instrument is ready for use. If the equipment is used during the warm-up period, frequency calibration adjustments may be necessary.

#### a. Classification of Input Signals.

Generally, input signals to the spectrum analyzer can be divided into two types: discrete and non-discrete. Discrete signals are periodic waveforms with frequency contents which do not vary appreciably with time. The internal markers of the equipment are typical of such a signal. Although there are several frequency components, each frequency is discernible as a separate pip providing the resolution of the spectrum analyzer is adequate for the frequency differences encountered. In practice, discrete signals are typical of periodic oscillation such as signal-generator and oscillator outputs and transducer outputs if a periodic vibration is encountered; for example, constant-speed rotating machinery with a well-defined resonant vibration. Non-discrete signals are typified by a random noise in which the input frequency distribution must be considered as spread out over a band of the spectrum, rather than consisting of line spectra. Random signals vary with time but usually have a definable means (rms) level. Non-discrete signals are shown on the spectrum analyzer as a varying envelope of amplitude at each spectrum sample. Several scans through the noise input signal usually are adequate to establish a meaningful relative amplitude -versus- frequency analysis. The amplitude scales are equally valid for both random and discrete signals. However, the equipment sensitivity for discrete signals is different from that for random signals. Discrete signal levels should be compared to other discrete signal levels and random to other random levels when relative signal strengths are being determined. In a generally complex signal where both random and discrete signals are present, the spectrum analyzer will show on average the levels of the noise and the levels of the discrete signals correctly. That is, the random and discrete deflections on average would not change if one or the other were removed from the input signal.

Sections "b", "c", and "d" below give operating techniques for discrete-signal measurement. Section "e" gives operating techniques for noise measurements.

#### b. RELATIVE-VOLTAGE MEASUREMENTS OF DISCRETE SIGNALS.

(1) Set the following controls to the listed positions.

SWEEP WIDTH Dial ----- 3 MC

CENTER FREQUENCY Dial ----- 0 MC

IF BANDWIDTH ----- MAX  
 IF ATTEN ----- 0 DB  
 AMPLITUDE SCALE ----- LOG  
 VIDEO FILTER ----- OFF

(2) Connect the test signals to the spectrum analyzer. The method of connection depends upon the nature of the signal source. Paragraph II-3d gives methods to be used to connect test signals from different types of sources.

(3) For correct results, the following limits on the instantaneous peak voltage of signals connected to the INPUT receptacle must be observed. Failure to limit the level to the indicated voltages may result in incorrect amplitude readings and indications of frequency components which are not present in the input signal. It should be noted, however, that even if large amplitude bursts do occur, if they are of very short time duration they can be ignored. They will cause spurious response for a very short period of time and thus will not appear on the crt for any significant length of time.

Total Attenuation of

INPUT ATTENUATOR,

| STEP and CONTINUOUS                | 0 DB   | 20 DB | 40 DB | 60 DB | 80 DB |
|------------------------------------|--------|-------|-------|-------|-------|
| Maximum instantaneous peak voltage | 300 uv | 3 mv  | 30 mv | 0.3 v | 3 v   |

(LOG position of AMPLITUDE SCALE may not be used when IF ATTEN is set to 20 DB.)

When evaluating the input level, it is necessary to measure the total amplitude present at the input whether related or extraneous, whether in the frequency range of the equipment (200 cps to 15 mc or 200 cps to 25 mc) or outside of the frequency range. The input amplitude should be measured

with a broadband, fast-responding, peak-level indicator such as an oscilloscope\*. If the presence of signals not related to the signals of interest are of sufficient amplitude to overload the equipment, it is advisable to use appropriate filters to eliminate the unrelated signals. In the case of noise analysis (noise being defined as randomly fluctuating signals), unless it is definitely known that the level of signal present above the spectrum of interest is negligible, it is good practice to use a low-pass filter to attenuate signals above the spectrum of interest.

As a rough check for overload, it should be noted that overload can be assumed to occur if, with AMPLITUDE SCALE set to LOG and IF ATTEN set to 0 DB, deflections greater than full scale result. This does not mean that if the deflections are less than full scale, overload is not occurring.

Providing that the voltages indicated in the chart above are not exceeded, it is completely permissible to have crt deflections greater than full scale, thereby permitting study of low-level signals. The INPUT ATTENUATOR, STEP and, if necessary, the INPUT ATTENUATOR, CONTINUOUS are set to avoid overload. The IF ATTEN is then set appropriate to the level of signals to be measured.

(4) With the CENTER FREQUENCY dial set to 0 and AMPLITUDE SCALE set to LOG, adjust A BAL and S BAL for maximum suppression of the zero-frequency pip. It should be noted that it is perfectly normal for the amplitude of the zero-frequency pip to vary with time. If the frequency region being examined is sufficiently remote from 0 that the zero-frequency pip is not on the screen, it is only necessary to be sure that the zero-frequency pip is less than full scale on the LOG scale when IF ATTEN is set to 0 DB. It is good practice to confirm this degree of suppression occasionally. If the equipment is used near enough to 0 that the zero-frequency pip is on the screen, greater care in suppression may be required. If the zero-frequency pip is below full scale on the LOG scale with IF ATTEN set to 0 DB and the signal pips do not tend to ride on the zero-frequency pip, the suppression is satisfactory. If the signal pip amplitudes are being influenced by the zero-frequency pip, if possible, adjust the equipment to improve the resolving capabilities (reduce the sweep width, reduce the sweep rate, and/or narrow the if bandwidth). If improvement of the resolving capabilities does not separate sufficiently the zero-frequency pip from the signal pips, adjust A BAL and S BAL for a suppression of the zero-frequency pip that is sufficient to prevent influence on the amplitude of the signal pips.

---

\* Amplitude overloading of the input is determined by the instantaneous peak voltage of the input signal. However, in cases in which the peak amplitudes are no greater than 1.4 times the rms amplitude, a broadband true rms voltmeter may be used instead of an oscilloscope if more convenient.

(5) Adjust the CENTER FREQUENCY dial to bring the desired test signals on the screen. With the SPA-3/25, be sure that the CF VERN is set for the appropriate band. If a closer examination is required, the sweep width may be reduced. The Center Frequency VERNier control (concentric with the CENTER FREQUENCY control) may be used as a fine tuning adjustment. However, this use puts the CENTER FREQUENCY dial out of calibration. The dial may be restored to correct calibration by setting it such that the zero-frequency pip is at the center of the screen when the CENTER FREQUENCY dial is set to 0.

(6) The spectrum analyzer can be adjusted to provide any sweep rate from 1 cps to 60 cps. The spectrum analyzer sweep rate can be adjusted for synchronism to the power line, synchronism to an external signal, or non-synchronism. When the CAL-SYNC SEL switch is set to the EXT position, the sweep can be synchronized to a suitable signal connected to EXT SYNC receptacle (rear apron of analyzer chassis). When the switch is set to the LINE position, the sweep can be synchronized to the power line. When the SYNC AMP control is turned completely counterclockwise, the sweep operates without synchronism. The technique of adjusting the sweep rate is given in paragraph II-4e.

The choice of appropriate sweep rate and mode of sweep synchronism of the spectrum analyzer is determined by the nature of the signals being studied. For example, when the test signals are sporadic in occurrence, it is desirable to operate the equipment at high sweep rates to increase the probability of intercepting the signal. One way to obtain better resolution is to decrease the sweep rate. When examining pulse spectra, increasing the sweep rate will reduce the number of pulse lines per scan. Thus, a high synchronous sweep rate permits determination of the pulse repetition frequency and also permits examination for missing pulse lines. On the other hand, a low sweep rate will increase the number of pulse lines per scan, thus giving better definition to the shape of the spectral distribution envelope. Examination of distributed spectra (for example, random noise) requires low sweep rates to obtain good definition (see "e" below).

In most applications the unsynchronized-sweep mode of operation provides more information than does the synchronized mode. However, it is often more convenient for viewing purposes to synchronize the sweep. For example, when examining a signal, unresolved modulations may be revealed as amplitude bobbing of the screen presentation when the sweep is not synchronous with the modulation frequency. Synchronizing the sweep to the modulation frequency will stop the bobbing. When viewing pulsed rf signals, unsynchronized sweep will result in the continuous shifting across the screen of the pulse lines. This results in better definition of the spectral envelope. However, if examination for missing prf lines or



determination of the pulse repetition frequency is desired, it is more convenient to synchronize the sweep to the pulse, thereby causing a stationary pattern on the crt screen. Note that if the pulse is synchronized to the power line, synchronism is more easily provided by synchronizing the spectrum analyzer to the power line rather than to the pulse.

(7) The relative heights of the pip deflections on the crt screen are proportional to the relative amplitudes of the corresponding frequency components being analyzed, within the limits of flatness of response of the spectrum analyzer in the range of 200 cps to 15 mc (to 25 mc with the SPA-3/25). The specified flatness of response (see Section I-5f) will be applicable only if neither SWEEP WIDTH nor IF BANDWIDTH are changed. Changing the setting of these two controls may change the height of crt deflections.

Best accuracy of amplitude ratio measurement is provided by the PWR position of AMPLITUDE SCALE, least accuracy by the LOG position.

Note that it is permissible to exceed full-scale pip height to permit examination of low-level signals providing the equipment is not overdriven - see Section III-4b( 3).

To observe signals of comparable amplitude, AMPLITUDE SCALE should be set to LIN. The LIN scale of the crt screen is calibrated into ten divisions. The horizontal calibration lines are read at the right side of the screen.\*

On the other hand, simultaneous examination of signals of wide divergence of amplitude will require the LOG setting of this control. In this position, the calibration range is from 0 db to 40 db in 5-db divisions as indicated by the dots on the left side of the screen.\* Note that the LOG calibration does not hold when narrow pulses are measured.

In the PWR position, a power scale is provided. Pip height is proportional to the power (square of voltage) of the corresponding frequency component. Power ratios are read on the LIN scale of the crt screen. Note that because of ac coupling in the circuit, the PWR scale functions properly only with narrow pips and high sweep rates.

---

\* If so ordered, a calibrated screen can be supplied with horizontal lines for the logarithmic calibrations and dots for the linear calibrations.

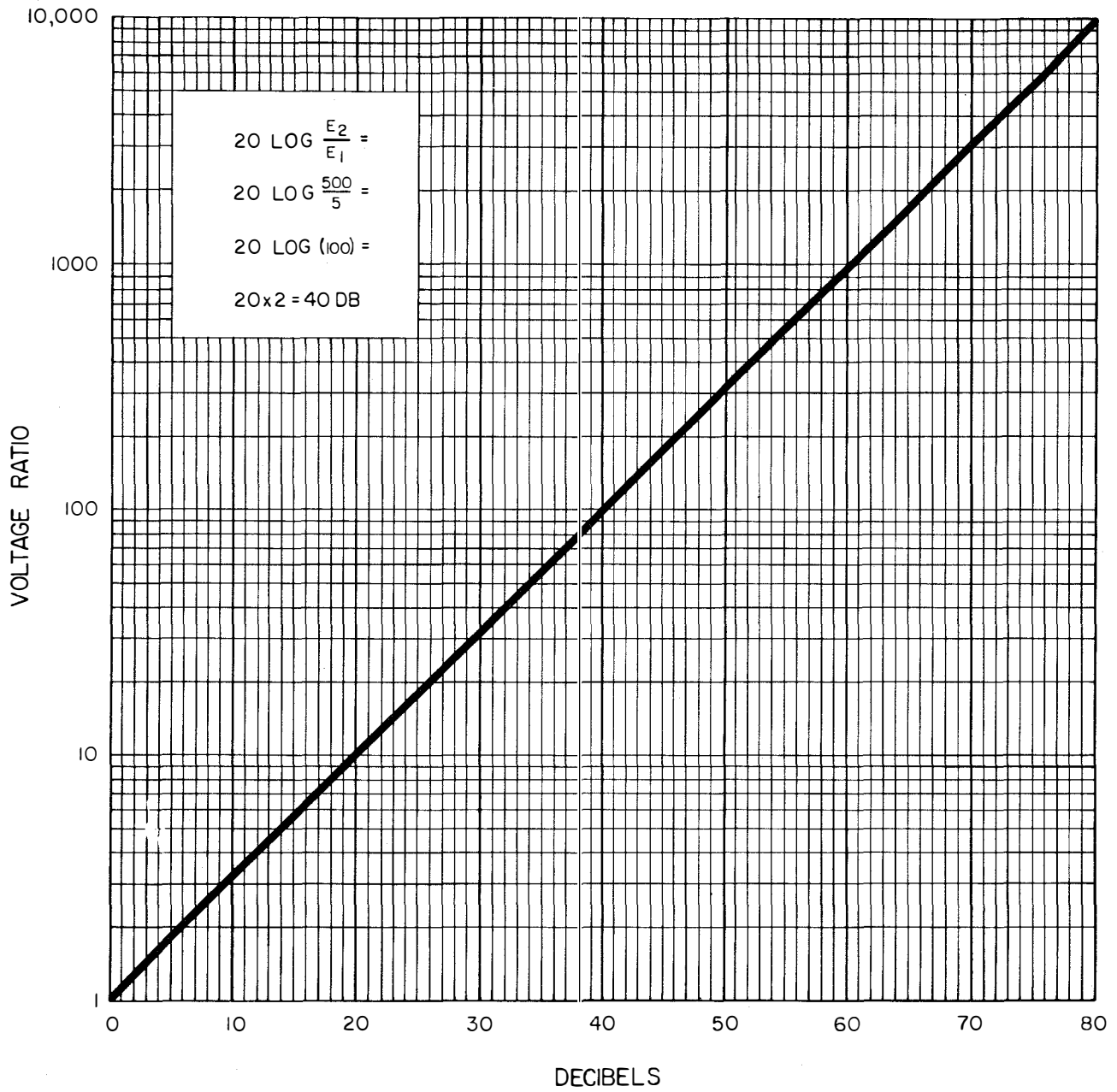

Figure III-4. Voltage Ratio - Decibel Conversion Chart.

Figure I-3 indicates the minimum frequency separation required to measure signals of unequal amplitude at various scanning velocities (scanning velocity being the product of sweep width and sweep rate). When there is a large difference in amplitude and the signals are close together, visual beats may interfere with measurement unless properly evaluated. To make the measurement, the center of the beat is used. This is illustrated in Figure III-5. The amplitude ratio in la is greater than that in lb, resulting in a somewhat different presentation.

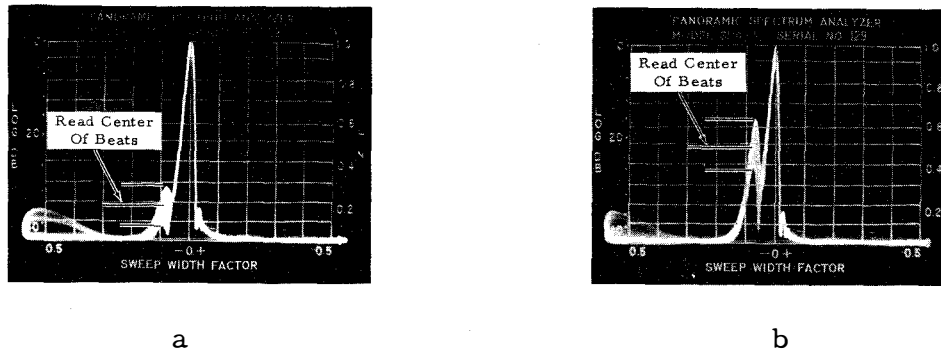
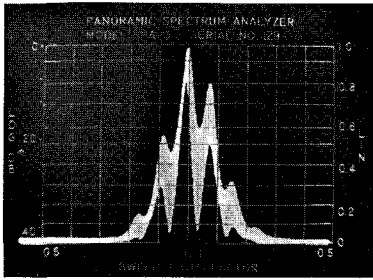

Figure III-5. Measurement of Closely Spaced Unequal Amplitude Signals.

(8) If noise, beats between adjacent signals, etc. make observations difficult, the VIDEO FILTER can be used to suppress such unwanted effects. However, if measurements permit, it is better to keep the control in the OFF position and adjust the equipment for better resolution (see Section III-4d) to eliminate beats between adjacent signals.

Clockwise rotation of VIDEO FILTER increases the amount of filtering. Excessive filtering will decrease the amplitude of pips on the screen and worsen resolution. The control, if used, should be adjusted for clearest picture with minimum loss of amplitude. It should be noted that the control has greatest useful effect at low sweep rates. At high sweep rates, the effect on the signal pips is too great for the control to be helpful.

Figure III-6 shows typical screen presentations obtained when the VIDEO FILTER control is used. In "a" a typical case of beating between signals is illustrated. The control is in the OFF position. In "b" the control has been adjusted for a clear picture with minimum loss of amplitude. In "c" excessive filtering is illustrated. Note the loss of amplitude and broadening of the pips.



a. Typical presentation.  
VIDEO FILTER in  
OFF position.

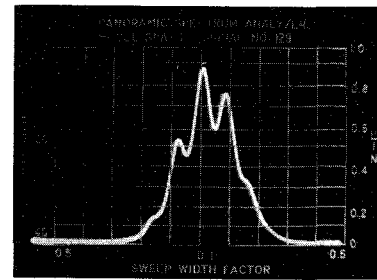

b. Suitable Degree of  
Filtering.

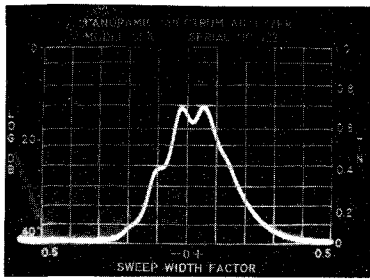

c. Excessive Filtering.

Figure III-6. Typical Screen Presentations Illustrating Adjustment of VIDEO FILTER Control.

### c. FREQUENCY MEASUREMENTS OF DISCRETE SIGNALS.

(1) Use the same technique for placing the signals to be studied on the crt screen as is given in "b" above. Since the pip shape is sharper on the LIN and PWR than the LOG position of AMPLITUDE SCALE, the LIN and PWR positions provide a better ability to measure frequency than does the LOG position.

(2) The CENTER FREQUENCY dial setting indicates the frequency of a pip at the center of the screen. (See III-4b(4) for a discussion of the Center Frequency Vernier.) Adding the reading of the SWEEP WIDTH dial times the crt screen SWEEP WIDTH FACTOR calibration point (preserving sign) over which the pip appears to the reading of CENTER FREQUENCY dial represents the frequency of the component to which the pip corresponds. For example:

CENTER FREQUENCY Dial Reading = 10 MC

SWEEP WIDTH Dial Reading = 2 MC

Pip appears over -0.2 division on crt screen

$$\begin{aligned} \text{Pip Frequency} &= 10 \text{ MC} + (2 \text{ MC}) \times (-0.2) = 10 \text{ MC} - 0.4 \text{ MC} \\ &= 9.6 \text{ MC} \end{aligned}$$

The internal frequency markers (500 kc and its harmonics) can be used to obtain more precise determinations of sweep width and center frequency than is possible with the calibrated dials.

(3) It should be noted that if frequency measurements are required which are of greater accuracy than that permitted by the calibration accuracy of the SWEEP WIDTH and CENTER FREQUENCY dials, a frequency-accurate signal may be connected to the input of the spectrum analyzer to determine the exact location of interesting frequencies. To do this, it is first necessary to remove the signals being measured or isolate them properly. More conveniently, the Panoramic Signal Alternator, Model SW-1, may be used to alternate to the input of the spectrum analyzer the test signal and the calibration signal, thereby avoiding interference between the two and permitting an exact optical overlay of the two signals.

(4) If noise, beats between adjacent signals, etc. make observations difficult, the VIDEO FILTER can be used to suppress such unwanted effects. The technique of adjusting the VIDEO FILTER is given in III-4b(8).

#### d. MEASUREMENT OF SIGNALS CLOSELY SPACED IN FREQUENCY.

At full sweep width, test signals, or a carrier and its sidebands, having a small frequency difference, tend to have their corresponding deflections merge into and mask each other. The ability of the equipment to separate individual signals (resolution) depends upon two factors: the scanning velocity (product of sweep rate and sweep width) and the bandwidth of the intermediate-frequency section of the equipment. For any given scanning velocity, there is a complementary if bandwidth for optimum resolution.

The scanning velocity is diminished by increasing the sweep period (reducing the sweep rate) and/or decreasing the spectrum width scanned within a given time (reducing the sweep width). Reducing the scanning velocity improves resolution (improves the ability of the equipment to separate closely spaced frequency components).

The IF BANDWIDTH control is used to adjust the intermediate-frequency-section bandwidth. Counterclockwise rotation of this control narrows the width of the if section. It should be noted that as this control is adjusted, there will be some degree of change in the sensitivity of the equipment. Narrowing the if bandwidth improves resolution until the point of optimum resolution (see III-4d(5)). Beyond this point, further narrowing of if bandwidth worsens resolution.

Figure I-2 indicates resolution versus sweep width for various sweep rates. It should be used as a guide to determine whether or not a given set of signals can be resolved and, if they can, at what control settings. For example, if a given number of equal amplitude sidebands each a fixed frequency apart are to be measured, the product of number of sidebands times frequency separation determines the sweep width required. The frequency separation of the sidebands determines the poorest resolution that can be used and still have separation of the sidebands. Figure I-2 can then be used to determine the fastest sweep rate that will provide the necessary resolution at the required sweep width.

Figure I-3 is a graph which indicates the minimum frequency separation that is required to measure amplitude ratios  $E_2/E_1$  at various scanning velocities (scanning velocity being the product of sweep rate and sweep width). If a signal of small amplitude is close in frequency to a signal of large amplitude, the pip due to the small signal will be influenced by the presence of the large pip. In effect, the small pip will ride on the skirt of the large pip (the amplitude-versus-frequency response of the intermediate-frequency section being bell-shaped). As the signals are separated in frequency, the error becomes less. The curves in Figure I-3 indicate the separation required for negligible error at the given scanning velocities.

To increase the resolution capabilities by reducing sweep width, narrowing the if bandwidth, and increasing scanning time, use the following procedure:

- (1) Set the IF BANDWIDTH control completely clockwise, the position for the broadest if bandwidth.
- (2) Adjust the CENTER FREQUENCY dial so that the desired band of signals is at the center of the screen.
- (3) Spread the band of signals across the screen by turning the SWEEP WIDTH dial counterclockwise. Note that at reduced sweep width each frequency calibration mark of the screen represents a frequency separation equal to one-tenth of the reduced sweep width.
- (4) Turn the IF BANDWIDTH control counterclockwise until individual signals are most clearly resolved. If the signals are not resolved, a slower sweep rate will have to be used. Optimum resolution can be recognized by the nature of the ringing pulses that will appear on the trailing

edge of the signal pip as optimum resolution is approached. See Figure III-7 and subparagraph (5) below. Ringing can be seen more easily with the VIDEO FILTER control in the OFF position.

NOTE: Rotation of the IF BANDWIDTH control may result in increased or decreased pip height. Pip amplitude may be returned to suitable level with the STEP and CONTINUOUS INPUT ATTENUATOR controls. Turning the IF BANDWIDTH control counterclockwise after optimum resolution is reached will decrease the resolving power and result in greatly reduced sensitivity.

(5) If the resolution results in practically complete separation of signal pips, maximum resolution can be recognized by the presence of ringing pulses on the trailing edge of the pip.

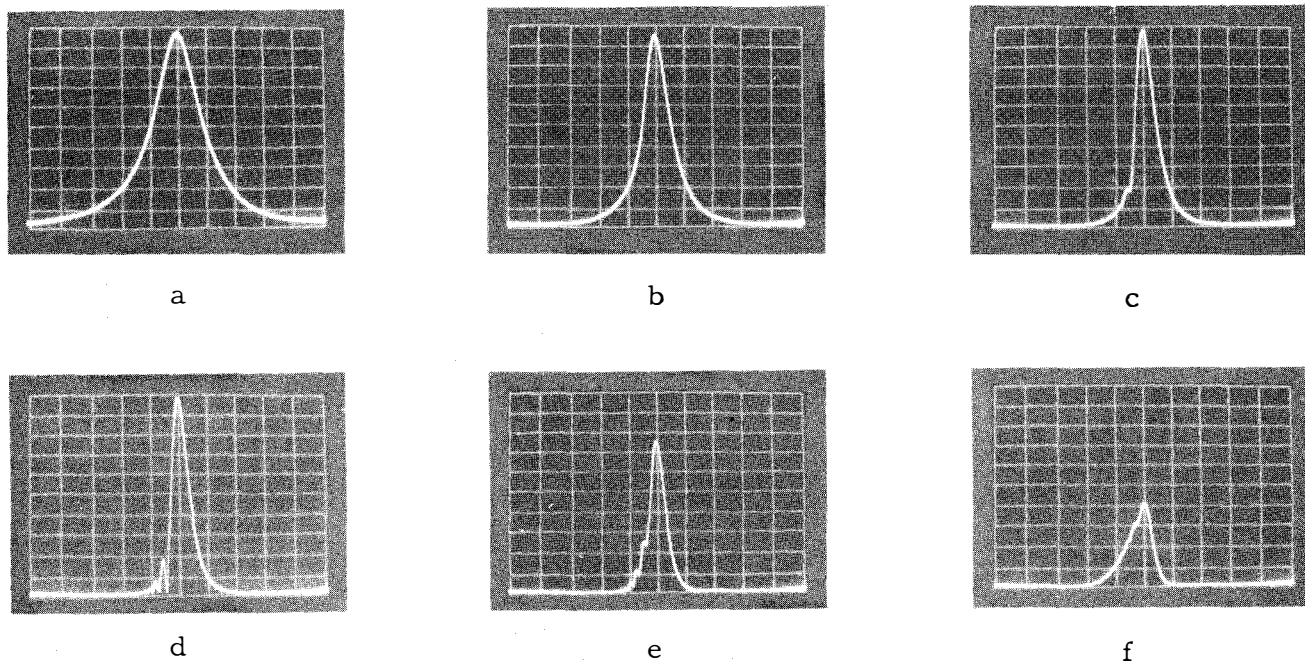

Figure III-7. Screen Presentations for Different Settings of IF BANDWIDTH Control.

Waveforms "a" to "f" of Figure III-7 indicate progressive variations in pip width effected by counterclockwise rotation of the IF BANDWIDTH control. In "a" and "b" the intermediate-frequency bandwidth is broad for particular scanning velocity (product of sweep rate and sweep width). Waveform "c" shows the beginning of ringing. On the LIN or PWR amplitude scale, with a full-scale or smaller pip, the notch between the signal pip and the ringing

pip nearest the signal pip extends into the baseline when the equipment is at optimum resolution. This is illustrated in waveform "d". On the LOG amplitude scale, with a greater than half-scale pip, the notch may not go to the baseline. In this case, optimum resolution is the point at which the notch is nearest the baseline. As the if section is made narrower, excessive ringing widens the signal pip and decreases the pip amplitude, thus reducing the resolving power. Further counterclockwise rotation of the IF BANDWIDTH control causes a reduction in amplitude and a tendency of re-merging of the pips. This is shown in waveforms "e" and "f".

(6) To separate the signals better, the sweep width, if bandwidth, and/or sweep rate can be reduced further.

If it is mandatory to observe a given sweep width at one time and the signals contained therein are so closely spaced that they cannot be completely resolved, maximum resolution is recognized by the appearance of the clearest picture. Further counterclockwise rotation of the IF BANDWIDTH control will result in lessened resolution and a bobbing presentation. Better resolution can be obtained by looking at a narrower sweep width than that of interest; and then shifting the center frequency to cover the spectrum segment of interest.

#### e. NOISE ANALYSIS.

In noise analysis (noise being defined as randomly fluctuating signals), the same general techniques are used for setting the equipment for the spectrum of interest as are used for discrete signals.

If the input spectrum is broadband, to prevent equipment overload, it is very important to monitor the input level. See paragraph III-4b(3).

The following special techniques should be noted.

In general, a fairly wide if bandwidth is preferred for noise analysis. This permits relatively rapid scans since a wide if bandwidth gives better noise envelope averaging than does a narrow if bandwidth. However, if the noise source is highly selective (for example, influenced by a structural resonance), an if bandwidth which is narrow compared to the bandwidth of the resonance is required. This permits presentation of fine detail of the noise characteristics. When a narrow if bandwidth is used, a low sweep rate is necessary for correct amplitude presentation. The appropriateness of the sweep rate can be determined by changing the sweep rate slightly and noting whether or not there is any change in the envelope amplitude. (The portion of envelope having the greatest slope should be watched since the greatest change in envelope will occur here.) The sweep rate should be slow enough that a small



change in sweep rate does not result in an amplitude change. If the sweep rate is at minimum, the sweep width should be reduced and/or the if bandwidth increased until it is possible to make a small change in sweep rate without changing the amplitude. Once a sweep which is slow enough to provide correct results has been established, a slower sweep can be set if improved envelope averaging is required.

In noise analysis, video filtering can be used to obtain averaging of the noise spectrum envelope. It is usually desirable to rotate the VIDEO FILTER control clockwise until a single-line presentation is obtained. The video filtering should not be too great (control too far clockwise) for the setting of IF BANDWIDTH. This can be checked by changing the sweep rate slightly and noting whether or not there is a change in the most sloped portion of the presentation.

In a general sense, the if bandwidth, VIDEO FILTER setting, sweep width, and sweep rate should be such that a slight change in sweep rate does not change the slope of the most sloped portion of the presentation. If this is not the case, it may be necessary to reduce the sweep rate, sweep width, or video filtering or increase the if bandwidth.

As an alternate to envelope averaging by video filtering, photographic averaging can be used. This is simply a matter of taking a composite photograph of a number of successive scans thereby obtaining an average presentation.

The equipment sensitivity listed in paragraph I-5e is applicable only to discrete signals. If absolute noise amplitude measurements are required, a calibration of the analyzer using a known noise amplitude should be made. Such a calibration must be made at the same scanning velocity (produce of sweep width and sweep rate) and if bandwidth used for measurement since change in scanning velocity and/or if bandwidth changes the amplitude. It is convenient to use the Panoramic Signal Alternator, Model SW-1, to display on alternate scans the calibration presentation and the analysis presentation.

Typical screen presentations with different control settings and different photograph exposure times of the same noise spectrum are shown in figure III-9. To obtain a convenient presentation amplitude, the input level and/or input attenuators have been adjusted as required.

In Figure III-8a the if bandwidth is narrow. The amplitude scale is linear. Since the scale is linear, the range of amplitude variation is emphasized compared to a logarithmic scale (see Figure III-9b). The use of a narrow if bandwidth also tends to emphasize the range of amplitude variation. The narrow bandwidth increases the likelihood of the equipment response at any given point being caused by a significantly higher or lower than average noise amplitude. If the if bandwidth is wide, it is more likely that the equipment response will be caused by a more typical noise amplitude. The result of using

a wide if bandwidth and a logarithmic amplitude scale is illustrated in Figure III-9e.

Figure III-9c and d illustrate the use of extended photographic exposure to provide a better averaging of the noise spectra. Figure III-9c is an extended photograph (many scans) of the spectra photographed for one scan in 9a while 9d is an extended photograph of the spectra photographed for one scan in 9b.

The use of video filtering to obtain averaging of the noise spectra is illustrated in Figures III-9f and g. With the equipment settings used for 9f, a slight change of sweep rate caused a significant change in the presentation, thus indicating the unsuitability of the settings. The sweep rate was reduced until no change in the presentation was noted. This is the correct response and is shown in Figure III-9g.

#### f. INTERPRETATION OF TYPICAL SCREEN PRESENTATIONS.

With a little experience, the operator will be able to recognize visually the character of the various types of signals.

- (1) An unmodulated constant signal appears as a pip of fixed height and fixed horizontal position. Reducing the sweep width widens the pip. See Figures III-8a and b.

Signal Interference. Two unmodulated constant signals which are close enough in frequency will appear as a single pip, varying in height as does an amplitude-modulated signal. Reducing the sweep width, reducing the sweep rate, and/or narrowing the if bandwidth may result in separation into two distinct pips. See Figures III-8c and d.

- (2) An amplitude-modulated signal (see Figures III-8e and f) with a modulating frequency which is lower than the resolution capability of the equipment will appear as a deflection of variable height. Non-constant tone modulation of low frequency will produce a series of convolutions varying in height, their number being determined by the modulation frequency. The nature of the presentation will depend upon the sweep width, the sweep rate, and the bandwidth of the intermediate-frequency section.

As the modulation frequency increases, the convolutions move toward the two sides of the deflection and the sidebands tend to become visible. When the modulation frequency is increased, it becomes possible to separate the sidebands by reducing the sweep width, reducing the sweep rate, and/or narrowing the if bandwidth. The higher the frequency of modulation, the farther away those sidebands will move from the center deflections, representing the carrier. In evaluating the level of the sidebands, the flatness

of response of the spectrum analyzer over the band of frequencies involved must be taken into account.

(3) A typical screen presentation of an amplitude-modulated single sideband signal without carrier suppression is shown in Figure III-8g.

(4) A pulse-modulated signal (see Figure III-8h) will consist of a pattern of vertical spikes. The number of spikes is dependent on the pulse repetition rate and the sweep rate of the equipment. The amplitude of each spike represents the amount of energy present at that particular frequency during one of the pulses. The peak envelope of all the spikes represents the energy-distribution pattern of the signal. When analyzing this type of signal, both synchronous and asynchronous displays should be viewed in order to determine the complete pattern.

(5) Typical screen presentations of frequency-modulated signals are shown in Figures III-8i and j.

(6) Transient disturbances, generally examined, are of two types: periodic and aperiodic transients. Periodic transients, such as produced by motors, vibrators, buzzers, etc., appear as signals moving along the frequency-sweep baseline in one direction or another. Thus, an engine which is accelerating will produce a set of deflections which may move first in one direction, slow down, stop and then move in an opposite direction. This is caused by the fact that the analyzer is sweeping at a fixed rate, whereas the transient occurs at a variable rate. The images stand still on the screen when there is synchronism between the two. If the transient disturbance is synchronized with the analyzer horizontal sweep, the "noise" appears as a fixed signal which, however, does not move on the screen when the center frequency is changed, but only varies in height. Such deflections may appear like amplitude-modulated signals or like steady carrier. Aperiodic transients, such as static, appear as irregular deflections and flash along the whole frequency sweep axis.

(7) Diathermy or other apparatus using an unfiltered or ac power supply will produce a periodic disturbance which will cause a deflection to appear on certain portions of the screen and not appear on other portions when the analyzer horizontal sweep is synchronized with the power line. This is due to the fact that such equipment emits a signal pulsating in synchronism with power line. On the other hand, the analyzer, too, is sweeping the spectrum in synchronism with the line, but at a lower frequency and only when a proper phase relationship exists is it possible for the analyzer to receive those periodic pulses.

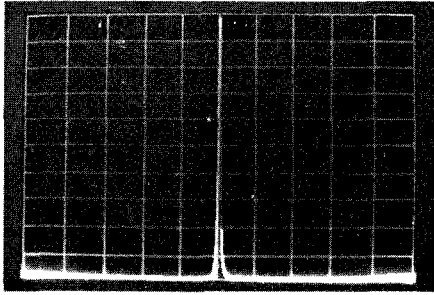

a. Constant carrier signal at approximately maximum sweep width.

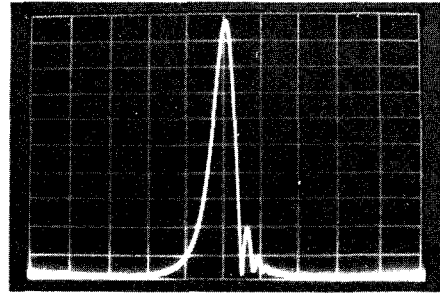

b. Appearance of constant carrier at reduced sweep width.

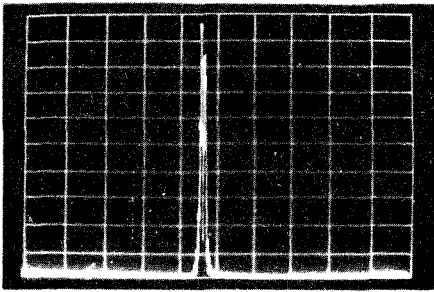

c. Two interfering carriers depicted at maximum sweep width.

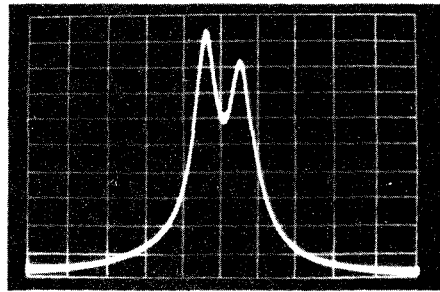

d. Same signals as in "c", sweep width reduced resulting in improved separation (resolution) of signals.

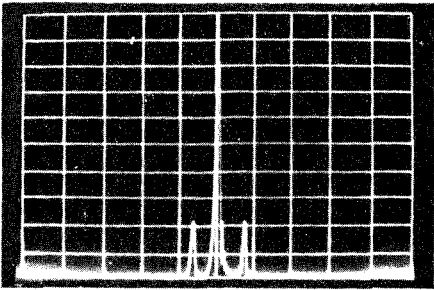

e. Amplitude-modulated signal showing carrier at the center and two sidebands.

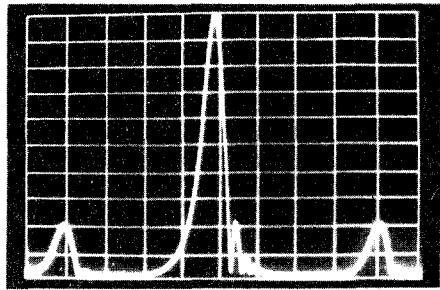

f. Same am signal as in "e" at reduced sweep width. Carrier remains at center of screen.

Figure III-8. Typical Screen Presentations For Discrete Signals.

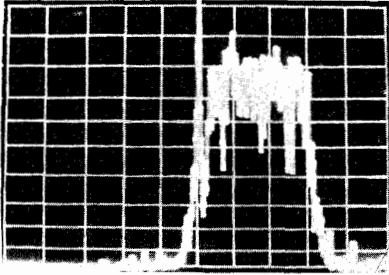

g. Single-sideband signal without carrier suppression.

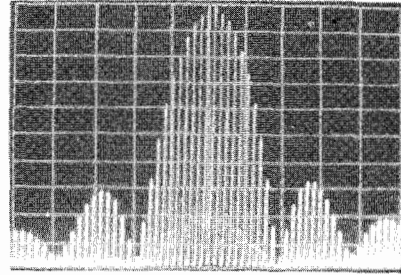

h. Spikes indicating distribution of a pulsed rf signal.

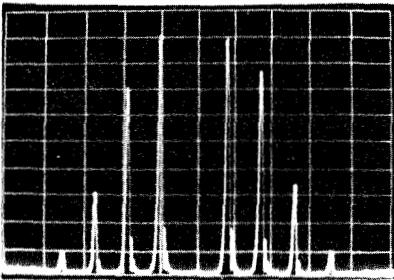

i. Frequency-modulated signal with carrier null.

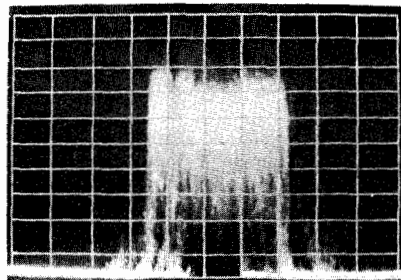

j. Typical sideband energy of fm signal, speech modulated. Slow sweep and/or extended exposure photography are used to display envelope averages.

Figure III-8 (cont'd).

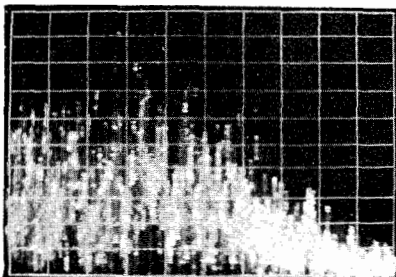

a. LIN Amplitude Scale. Narrow IF Bandwidth. One Scan.

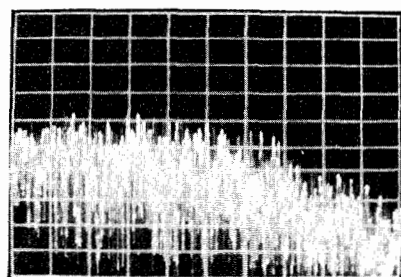

b. Same as "a" on LOG Amplitude Scale. (Input attenuation adjusted for convenient amplitude presentation.)

Figure III-9. Typical Screen Presentations For Noise Signals.

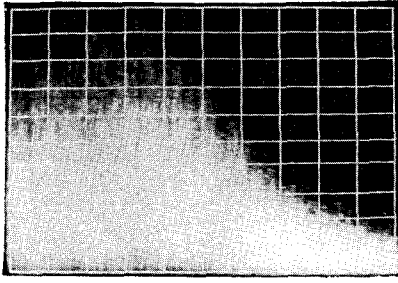

c. Same as "a" with extended photographic exposure.

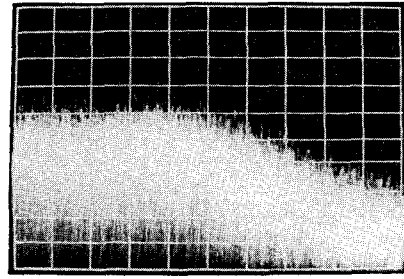

d. Same as "b" with extended photographic exposure.

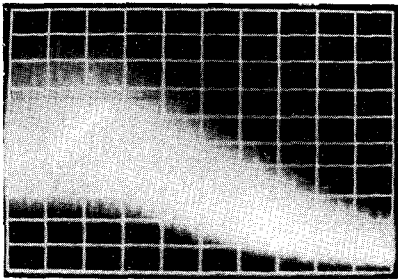

e. LOG Amplitude Scale. Broad IF Bandwidth. One Scan.

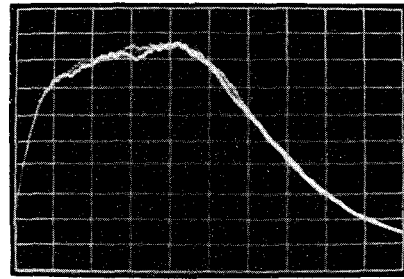

f. Same as "e". Video filtering used to obtain single line presentation. Sweep rate too fast.

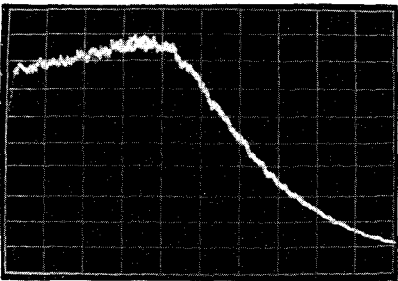

g. Same as "f" with sweep rate adjusted for correct presentation.

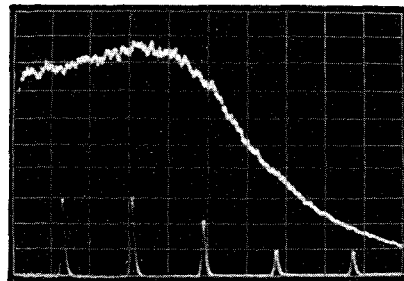

h. Same as "g" with marker presentation used to define frequency points.

Figure III-9. Typical Screen Presentations for Noise Signals  
(continued)







## CHAPTER IV THEORY OF OPERATION

### IV-1. INTRODUCTION.\*

The Panoramic Spectrum Analyzer is a scanning heterodyne instrument which automatically provides a visual, two-dimensional display of the frequency components of a complex wave, in any selected 0- to 3-mc segment of the region between 200 cps and 15 mc (between 200 cps and 25 mc with the SPA-3/25). The display appears on the screen of long-persistence, flat-faced, cathode-ray tube, as vertical deflections distributed horizontally in order of component frequency. The frequency presentation is linear. The height of a given vertical deflection indicates the relative magnitude of its corresponding frequency component.

The spectrum analyzer consists basically of a calibrated input attenuator, an input cascode amplifier, a wide-band amplifier (SPA-3/25 only), a phase splitter, a sweeping oscillator, a balanced mixer, an intermediate-frequency-section attenuator, a 32-mc if amplifier, a 29.3-mc crystal oscillator, a second mixer, variably selective intermediate-frequency amplifiers (2.7 mc), a detector, vertical and horizontal deflection amplifiers, a sweep generator, and a cathode-ray-tube indicator.

In the balanced mixer, the sweeping-oscillator signal progressively heterodynes, in order of frequency, with those signals at the output of the phase splitter. Oscillator signal and even-order modulation products are balanced out in the mixer leaving only the input signal and sum and difference terms of the input and oscillator frequencies. Whenever the difference frequency is 32-mc, it is passed by the sharply tuned 32-mc intermediate-frequency section. The output of the 32-mc if section is mixed with the output of the 29.3-mc crystal oscillator.

The 2.7-mc product of this mixing passes through a 2.7-mc variably selective if section. The output voltage of the 2.7-mc if section is proportional to the amplitude of the sampled portion of the input signal. This output is detected, amplified, and applied to the vertical deflection plates of the cathode-ray tube. The vertical deflection appears at a definite location along the horizontal axis according to signal frequency since a common sawtooth voltage source is used for both the sweeping oscillator and the horizontal deflection of the crt beam.

Oscillator sweep is obtained with a sawtooth-modulated circuit (consisting basically of a voltage-controlled tuning inductor) which controls the frequency of the swept oscillation. A calibrated SWEEP WIDTH control varies the amplitude of

---

\* Refer to Block Diagram (Figure IV-1) and Schematic Diagrams for supporting information.

the modulating sawtooth to permit selection of any sweep width from 0 to 3 mc. A calibrated CENTER FREQUENCY control capacitively tunes the swept oscillator to permit selection of any center frequency between 0 and 13.5 mc (0 and 23.5 mc in the case of SPA-3/25).

#### IV-2. CIRCUIT DESCRIPTION, MODELS SPA-3 and SPA-3/25 ANALYZER SECTION.

##### a. Input Circuit.

The input circuit consists of a STEP INPUT ATTENUATOR switch (S101), a CONTINUOUS INPUT ATTENUATOR control (R125), an input cascode amplifier (V101, V102 in the SPA-3 and V101A, V101B in the SPA-3/25), a wide-band input amplifier (V102 - found only in the SPA-3/25), and a phase splitter (V103).

Input signal is directly connected to the INPUT type BNC connector (J101) if the signal is derived from a 72-ohm source. If signal is derived from other than a 72-ohm source, matching pads are required or the signal may be connected to the INPUT connector through a cathode-follower probe (see Section IV-1).

The signal at the INPUT connector passes to the grid of V101 (V101A in the SPA-3/25), part of the input cascode amplifier, through the STEP INPUT ATTENUATOR switch. This switch can provide 80 db of attenuation in increments of 20 db. The CONTINUOUS INPUT ATTENUATOR control varies the grid bias of V101 to provide a continuous means of varying the attenuation of the input signal. The control has a range of at least 20 db.

The output of the input cascode amplifier is connected to the phase splitter (in the case of the SPA-3) which produces two outputs approximately 180 degrees out-of-phase, one from the plate of V103A and one from the plate of V103B. In the SPA-3/25, output from the input cascode amplifier is connected to an input wide-band amplifier (V102) which in turn is connected to the phase splitter.

The outputs from V103A and V103B are coupled to the control grids of V104 and V105, respectively.

Shunt peaking networks in the plates of V102, V103A, and V103B (and V101 in the SPA-3/25) improve the high-frequency amplitude response of the input circuit.

b. Frequency Markers.

Frequency markers, consisting of a 500-kc signal and its harmonics, are generated by a 500-kc crystal oscillator (V115A) and a cathode follower output amplifier (V115B). The parameters of the output amplifier were chosen for rich harmonic generation.

The MARKER AMPLITUDE control (R337, S104) forms the cathode resistor of the cathode follower. The control has a switch which, in the OFF position, removes B+ from the marker generator.

The marker output is coupled to the grid of one section of the phase splitter (V103)\*.

c. Sweeping Oscillator.

The sweeping oscillator (V118) is a push-pull oscillator of the tuned-plate type. The frequency-discriminatory circuit of the oscillator consists basically of the secondary of a voltage-controlled tuning inductor (L127) and the CENTER FREQUENCY control (a dual tuning capacitor, C265 A, B).

The inductance of the secondary of the voltage-controlled tuning inductor depends upon the voltage applied to its primary. A linear sawtooth is applied to the primary. The inductance of the secondary varies with this sawtooth voltage, thus changing linearly from one inductance value to another inductance value and then snapping back to the original value. Thus the frequency of the oscillator changes linearly from one frequency to another frequency and then snaps back to the original frequency.

The sawtooth drive to the tuning inductor is derived from the sawtooth generator (V121). The maximum amplitude of sawtooth available to the tuning inductor and thus the maximum sweep width of the instrument is determined by the setting of the SWEEP LIMIT control (R421). Changing the setting of the front panel SWEEP WIDTH control (R349) changes the amplitude of the sawtooth current drive to the tuning inductor and thus the extent of inductance change and thus the extent of oscillator frequency change. The sawtooth voltage output from the SWEEP WIDTH control is amplified by a sawtooth amplifier (V117) and then connected to the tuning inductor. The mid-frequency of the oscillator is changed by changing the setting of the front-panel CENTER FREQUENCY control, a dual capacitor, which is part of the frequency-discriminatory circuit of the oscillator. A variable capacitor (C267) which is

---

\* In equipments, serial number 169E --- and earlier (169D---, 169C---, etc.), the marker output was connected to the grid of V102 (p/o the input cascode amplifier).

in parallel with one section of the CENTER FREQUENCY control serves as a center-frequency vernier.

As the center frequency is increased, the inductance change of the tuning indicator required for any particular fixed sweep width becomes less and less. A variable resistor, SWEEP WIDTH TRACK (R345), mechanically linked to the CENTER FREQUENCY control, reduces the sawtooth current drive to the tuning inductor as the center frequency is increased. This maintains a nominally constant sweep width as center frequency is changed.

The center-frequency range of the sweeping oscillator is set with L129 and C163 (the OSC TRIMMER). Variable inductance L129 is used to set the zero-frequency end of the CENTER FREQUENCY dial. The OSC TRIMMER is used to set the 13.5-mc end of the dial on the SPA-3 and is used to set the high-frequency end of the dial on the LO band on the SPA-3/25.

The temperature stability of the inductance of the voltage-controlled tuning inductor depends upon the current flow through the inductor. The BIAS control (R353) is used to set the center-frequency current flow for minimum inductance-versus-temperature drift thereby minimizing the center frequency-versus-temperature drift of the sweeping oscillator.

Output from the sweeping oscillator is coupled to the control grids of two oscillator output amplifiers (V119A, V119B). The output from V119A is coupled to the common cathode of the balanced modulator. The output from V119B is coupled to the G-6 OUTPUT connector which is located on the rear apron of the chassis. This connector provides the source of sweeping-oscillator signal necessary to drive the auxiliary Panoramic Video Response Indicator, Model G-6.

To provide a stable B+ voltage for the sweeping-oscillator section (V117, V118, V119), a voltage-regulating tube (V116) is used.

In the SPA-3/25, switch S106 (the BAND selector switch) selects parameters appropriate to the two center-frequency bands.

#### d. Balance Modulator.

The two out-of-phase outputs from V103A and V103B (the phase splitter) are coupled to the control grids of V104 and V105 (the balanced modulator), respectively. Sweeping-oscillator signal is coupled to common cathode of the two balanced-modulator tubes.

Sum and difference products of the mixing of the input signals with the sweeping-oscillator signal, as well as the input signals themselves, appear at the output of the balanced modulator. Sweeping-oscillator signal balances out in

the output circuit of the balanced modulator. To compensate for any unequalness in the balanced modulator tubes and circuitry, three controls are employed to maximize the cancellation of sweeping-oscillator signal. The front-panel controls, A BALance and S BALance, have a differential effect on the output of the balanced modulator; A BAL by changing differentially the plate load of the balanced-modulator tubes and S BAL by changing differentially the screen voltages and thus the gain of the balanced-modulator tubes. Variable capacitor C131, a chassis control, is used to obtain suitable phase balance between the outputs of the two sections of the balanced modulator.

e. 32-MC Intermediate-Frequency Section, 29.3-MC Crystal Oscillator, and Mixer.

The 32-mc if section consists of three 32-mc bandpass filters (T101, T102, T103), an IF ATTEN switch (S102), and an amplifier (V106A).

The balanced modulator output is connected to an intermediate-frequency section which is tuned sharply to 32 mc. Each time a 32-mc mixing product is produced in the balanced modulator, a pulse will pass through the 32-mc if section. This pulse corresponds to a particular input signal. All other frequencies are attenuated greatly. The front-panel control IF ATTENUATOR permits the selection of 0 db or 20 db of attenuation of the pulse which in effect is 0 db or 20 db of additional attenuation of the input signal. The IF ATTENUATOR ADJUST chassis control permits setting the IF ATTEN control for correct attenuation. The IF GAIN chassis control in the cathode of V106B permits adjusting the gain of this 32-mc if amplifier to set the input sensitivity of the analyzer.

The output from the 32-mc if section is mixed in mixer V107 with the output 29.3-mc crystal-controlled oscillator to generate, among other outputs, a 2.7-mc output. This 2.7-mc output passes through the 2.7-mc variably selective intermediate-frequency section.

f. 2.7-MC Variably Selective Intermediate-Frequency Section.

The 2.7-mc variably selective if section consists of a 2.7-mc bandpass filter (T104), a first 2.7-mc crystal-filter stage (V108, Y102), a first 2.7-mc tuned if amplifier (V109A), a second 2.7-mc crystal-filter stage (V109B, Y103), a second 2.7-mc tuned if amplifier (V110, T105), and a third 2.7-mc tuned if amplifier (V111, T106).

The input to the 2.7-mc if section is a bandpass filter tuned to 2.7 mc which passes 2.7-mc products appearing at the output of mixer V107 and greatly attenuates all other frequencies. The if signal passes through the five-stage if section (V108, V109A, V109B, V110, V111) which includes two identical

2.7-mc quartz-crystal filters (Y102, Y103). Associated with each crystal filter is an LC tuned circuit (C169, L111; C189, L117) and associated with each tuned circuit is one section of a dual potentiometer (R225A, R225B) which is the front-panel control IF BANDWIDTH. The bandwidth of the if section is determined by the bandwidth of the two combinations of tuned circuit and crystal filter. The bandwidth of the tuned circuits are determined by the setting of the IF BANDWIDTH control.

The frequency resolution, or ability to separate individual frequency components, is a function of the scanning velocity (frequency scanned per unit time) and the bandwidth of the intermediate-frequency stages.

The presence of "ringing" on trailing edge of the pip indicates that the equipment is close to or at optimum resolution. Assuming a fixed scanning velocity, the illustrations in Figure III-7 show the changes in the screen presentation of a single frequency input when the if bandwidth is made progressively narrower.

In (a) and (b), the if bandwidth is broad for the particular scanning velocity. (c) shows the beginning of "ringing". The extent of "ringing" in (d) indicates optimum resolution. Note that the "ringing" pip closest to the signal pip extends to the baseline. As the if section is made narrower, excessive "ringing" widens the pip and the signal pip amplitude decreases.

The output from the last (third) 2.7-mc tuned if amplifier (V111, T106) is connected to the LIN-LOG detector (V112) and the PWR detector (V113A).

In the LOG position of the AMPLITUDE SCALE selector switch, section S103A connects output from the LIN-LOG detector through the secondary of T105 to the grid of V111. This negative feedback, the amplitude of which is determined by the setting of the 0 DB LOG adjust control (R270), causes the effective output of V111 to vary logarithmically with signal input. In the LIN and PWR positions the point of connection of the feedback voltage is grounded and the output of V111 is linearly proportional to signal input. Section S103B of the AMPLITUDE SCALE switch changes the cathode bias of V111 and thus the gain of V111 appropriate for the three amplitude scales. In the LOG position of AMPLITUDE SCALE the 20 DB LOG ADJUST control (R261) is used to adjust the cathode bias of V111 (and thus the gain of V111) such that a full-scale deflection on LIN and PWR, appears at the 20-db crt calibration point on the LOG position. The 20 DB LOG ADJUST control sets the feedback amplitude for a 20 db difference in amplitude between a pip of 0-db deflection and a pip of 20-db deflection on the crt screen.

g. Detectors.

The 2.7-mc output from the if section is connected to the detector for the LIN-LOG amplitude scale (V112), a triode whose plate and grid are connected to form a diode. The output from the detector is connected to section S103C of the AMPLITUDE SCALE selector switch.

The 2.7-mc output from the if section is also connected to the grid of V113A, the square-law detector for the PWR amplitude scale.

The output from the square-law detector passes through an amplifier (V113B) to section S103C of the AMPLITUDE SCALE selector switch.

Switch selector S103C determines whether output from the LIN-LOG detector or the output from the square-law detector is connected to the grid of the vertical amplifier (V114A).

Output from the LIN-LOG detector is connected through the audio amplifier (V112B) to the AUDIO OUTPUT connector. This output connector permits aural monitoring when the equipment is set for zero sweep width.

h. Vertical Push-Pull Amplifier.

The output from either the LIN-LOG detector or the amplified output from the square-law detector (selected by section S103C of the AMPLITUDE SCALE switch) is connected to the grid of the vertical amplifier (V114A).

An RC video filter is connected to the grid of the vertical amplifier. The resistive element of the filter is variable (R307, VIDEO FILTER). A switch (part of the VIDEO FILTER control) permits disconnection of the video filter from the circuit.

Output from the vertical amplifier is directly coupled to one vertical deflection plate of the cathode-ray tube and is connected to the vertical phase inverter and amplifier (V114B).

The output from the phase inverter (which is 180 degrees out-of-phase with the output from the vertical amplifier) is directly coupled to the other vertical deflection plate of the cathode-ray tube. The setting of the V POS control (R325) determines the cathode voltage and thus the plate voltage of V114B. This determines the vertical position of the crt beam.

In the CAL position of the CAL-SYNC SElector switch, switch section S105B connects heater voltage into the cathode circuit of the vertical phase inverter. This permits calibration of the sweep rate.

i. Sawtooth Generator.

The sawtooth sweep voltage is derived from the sawtooth generator and sawtooth-output cathode follower (V121) and E101 (an NE16 neon lamp). The pentode section of V121 acts as a Miller-type sweep generator. Resistors R401A (one section of the SWEEP RATE control) and R399 and capacitor C289 in the grid circuit provide a time constant which controls the negative-going voltage on the grid. This change in grid voltage is amplified in the pentode section and is fed back 180 degrees out-of-phase through the triode cathode-follower section of the same tube. This amplified positive-going voltage tends to slow down the rate of negative change of the grid of the pentode section. This results in a linear, positive sawtooth voltage at the output of the cathode follower. When this voltage reaches a pre-determined amplitude, E101 conducts restoring the grid of the pentode section of the V121 to its initial condition. (The conduction time for E101 is the retrace time of the sawtooth.)

R401B (the other section of the SWEEP RATE control), which is in the crt negative voltage bleeder string, determines the level of the negative-going voltage applied to the grid of the pentode section of V121. This negative-going voltage determines the amplification of the pentodesection of V121 which in effect amplifies the time constant.

When the negative grid bias voltage of the pentode section of V121 is at a minimum, the amplification of the time constant will be the greatest. At the same time, the second section of the dual potentiometer is at greatest resistance or highest time constant. Rotation of the SWEEP RATE control in a clockwise direction results in a higher sweep rate. In the fully clockwise position, the sweep rate is approximately 60 cps. In the fully counterclockwise position, the sweep rate is approximately 1 cps.

To synchronize the sawtooth generator, the differentiated output from the sync amplifier is connected through the SYNC AMPLitude control to the conductive coating of E101.

The electrostatic effect of voltage pulses appearing on this coating will change the voltage required to cause E101 (the sawtooth discharge tube) to conduct. A pilot lamp, DS101, is located adjacent to E101. The function of DS101 is to maintain a constant ionization level in E101 by photo-electric effect, thereby maintaining a constant conducting voltage. (If DS101 is not lit, erratic operation of the sweep circuit may occur.)

In the CAL or LINE position of the CAL-SYNC SElector switch, switch section S105A connects ac heater voltage to the grid of the sync amplifier (V120) thereby synchronizing the sawtooth generator to the power line.

The EXT position of the CAL-SYNC Selector permits synchronization with



external voltages which may be connected to the EXT SYNC connector (J125).

Turning the SYNC AMP control completely counterclockwise removes synchronizing voltage from E101 allowing the sawtooth generator to be free running.

The output from the sawtooth generator is connected to both the sweeping oscillator (see section c above) and the horizontal push-pull amplifier.

To provide a sawtooth voltage of zero average dc level, a negative voltage, whose level is determined by the setting of the CF BAL control (R131), is connected at the output of the sawtooth generator to cancel the normally positive average dc level of sawtooth output. This permits correct baseline centering.

#### j. Horizontal Push-Pull Amplifier.

Sawtooth voltage derived from V121B is connected to the grid of the horizontal amplifier (V122A). Output from the horizontal amplifier is directly coupled to one horizontal deflection plate of the cathode-ray tube. The setting of the H POS control (R431) determines the cathode bias and thus the plate voltage of V121B. This determines the horizontal position of the crt beam.

Output from the horizontal amplifier is also connected to the horizontal phase inverter and amplifier (V122B). The output from the phase inverter (which is 180 degrees out-of-phase with the output from the horizontal amplifier) is directly coupled to the other horizontal deflection plate of the cathode-ray tube.

The LINE SIZE control (R415) determines the level of sawtooth connected to the horizontal amplifier and thus the extent of the horizontal deflection of the crt beam. When an external sweep source is used, the EXT LINE SIZE control (R417) is adjusted such that the same baseline length is obtained with either the internal sawtooth generator or the external sweep-voltage generator.

Sawtooth from V122A is connected to the SYNC PULSE OUTPUT receptacle (J130) through an RC differentiating circuit which shapes the sawtooth wave into a sharp pulse. This pulse may be used to synchronize to the spectrum analyzer sweep, the Panoramic Signal Alternator Model SW-1, camera shutters, and/or auxiliary indicators.

#### k. Visual Indicator.

A type 5ADP7 cathode-ray tube is used as a visual indicator. A voltage-doubler high-voltage system is used to drive the crt. Negative high voltage is connected to the electron gun. Positive high voltage is connected to the post accelerator anode. The FOCUS and BRILLIANCE controls are located in the negative high voltage bleeder string. The ASTIGMATISM control is used to adjust the crt trace for uniform focus.

## 1. ACCESSORY EQUIPMENT RECEPTACLE AND SHORTING PLUG.

The ACCESS EQUIP receptacle (J129) is provided to permit the convenient connection of accessory equipment to the spectrum analyzer. The shorting plug (P129) must be connected when normal operation is required.

When the shorting plug is connected, the jumper wire between contacts G and F connects the sawtooth generator (V121) to B+. The jumper wire between contacts D and A connects the output of the sawtooth generator to the sweep-oscillator and horizontal circuits.

When the shorting plug is disconnected, the internal sawtooth generator is turned off. A 250-v regulated B+ supply is available at contact F. A -85-v regulated B- supply is available at contact H. An external sweep source may be connected at contact B. Contact C is a ground connection. Contact J provides detected vertical output.

## IV-3. CIRCUIT DESCRIPTION, MODEL PS-19.

The Model PS-19 furnishes all necessary power for the analyzer section at the indicated contact of connector J7 as follows:

- |                          |                |
|--------------------------|----------------|
| (1) +250-v dc, regulated | - Contact H    |
| (2) -1650-v dc           | - Contact L    |
| (3) +1650-v dc           | - Contact N    |
| (4) -85-v dc, regulated  | - Contact D    |
| (5) 6.3-v ac             | - Contacts P-M |
| (6) 6.4-v ac             | - Contacts A-B |
| (7) 6.3-v ac             | - Contacts E-F |

Note: Dc voltages are from contact to chassis.  
Ac voltages are between indicated contacts.

The power input to the Model PS-19 is derived from a constant-voltage transformer which provides a stable source of 115-v, 60-cps power when connected to a 60-cps power source (95-130v). (Constant-voltage transformers for other power sources are available on special order.)

The +250-v dc is provided by a full-wave rectifier (V1). Filtering is introduced by R1, R3, C5, and C7. Regulation is accomplished by V2, V3, V4, V5, and V6. The voltage-regulator tube (V6) provides a reference voltage for the regulator-control tubes (V3, V4). The regulator-control tubes serve as a dc amplifier which amplifies and feeds back to the grids of the series regulator (V2, V3) any voltage change in the +250-volt line. This feedback changes the cathode-to-plate voltage drop across V2, V3 so as to oppose the change in the +250-volt line. The +250 V ADJ control (R39) is used to set the grid voltage of V5B so that regulation

produces a nominal voltage of +250-v dc.

Negative high voltage for the cathode-ray tube is provided by a half-wave rectifier (CR3). Filtering is introduced by R51 and C19A, B.

Positive high voltage for the cathode-ray tube is provided by a half-wave rectifier (CR5). Filtering is introduced by R57 and C21A, B.

The -85-v dc supply is provided by a half-wave rectifier (CR1). Filtering is provided by C15, R47 and C17. V7 serves as a voltage regulator for the negative supply.

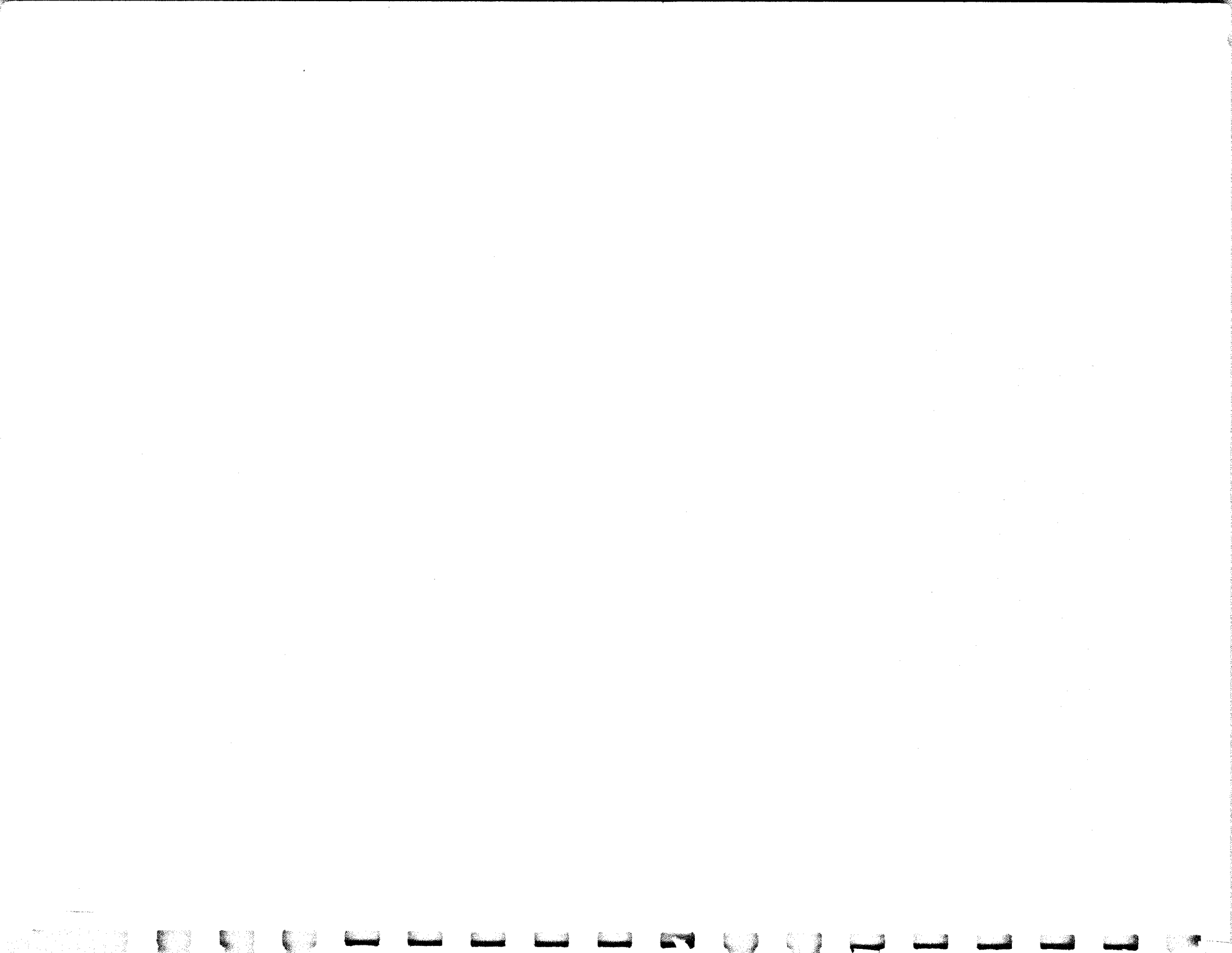

## CHAPTER V SERVICE AND MAINTENANCE

This chapter is divided into five sections to facilitate its use in connection with adjustment, repair, or alignment of the equipment.

Section 1 is a guide to trouble shooting. The trouble-shooting chart lists principal trouble symptoms and their corrective measures. As an aid to trouble-shooting, a voltage and resistance chart and a stage-gain chart are provided.

Section 2 outlines the nature of the touch-up alignment that may become necessary because of aging or replacement of any of the tubes (and/or associated components) of the equipment.

Section 3 indicates the functions of the service controls and components.

Section 4 is a complete field alignment procedure. It is only under the most unusual circumstances that this procedure will have to be used in its entirety. Most of the alignment problems encountered in the field can be solved by using the applicable adjustment techniques suggested in Section 2.

Section 5 is a final testing procedure used to determine whether the equipment is within specifications after it has been repaired.

### V-1. TROUBLE SHOOTING.

This section is a guide to trouble shooting the equipment. The trouble-shooting chart, voltage and resistance chart, and the stage-gain chart are used to localize the fault to the defective stages and components responsible for the abnormal condition.

#### a. TROUBLE-SHOOTING CHART

This chart lists the principal trouble symptoms which may be observed while making tests. For each symptom, corrective measures are indicated. When a check of a tube is listed, the tube and its associated circuitry should be investigated. The voltage and resistance chart and the stage-gain chart can be used to help pin-point the cause of trouble.

## SYMPTOM

Pilot lamp does not light.

3-ampere fuse (F1, F2)  
fails when replaced.

No crt illumination.  
Pilot lamp lit. Not  
corrected by adjust-  
ment of FOCUS and  
BRILLIANCE

## CORRECTIVE MEASURES

Replace pilot lamp.  
Check power connections.  
Check 3-ampere fuses (F1, F2).  
Check output voltage from constant-voltage transformer. Low output may be caused by defective cv transformer or by short circuit in the power supply or analyzer.

Check T1, T2 and their loads.  
If fuse fails immediately, check for shorted power transformer. Check for ac filament short.  
If fuse fails after approximately 30 seconds, check for B+ short.

Check seating of anode contact of crt.  
Check seating of shorting plug in ACCESS EQUIP. receptacle.  
If removal of V111 from its socket results in crt illumination, check intermediate-frequency section for oscillation and swept-oscillator section for failure.  
Check high voltage. If high voltage incorrect, check CR3, CR5, and associated filter circuits.  
Check V121 (including neon lamp E101, mounted under the chassis) and V122. Note that the mid-point of the saw-tooth swing should be approximately the same at the two horizontal deflection plates of the crt.  
Check V114. Note that there should be an approximately 60-volt difference between the two vertical deflection plates of the crt.  
Check V123.

## SYMPTOM

## CORRECTIVE MEASURES

Crt illumination observed but baseline not obtained. (Stationary dot on crt screen.)

Check seating of shorting plug in ACCESS EQUIP. receptacle.  
Check B+ at J5, +250 V TEST. If necessary, adjust +250 V ADJUST. Check V1 to V6.  
Check V121 (including neon lamp E101, mounted under the chassis) and V122.

Baseline length and/or horizontal position incorrect. Not corrected by turning SYNC AMP. counterclockwise.

If baseline too long and sensitivity too great, check for insufficient high voltage. If high voltage incorrect, check CR3, CR5, and associated filter circuits.  
Check V121 (including neon lamp E101, mounted under the chassis) and V122.  
Reset LINE SIZE, H POS, and CF BAL per V-2b(8).

Baseline cannot be synchronized.

Check that lamp DS101 (under the chassis near E101) is lit.  
Check V120.

SWEEP RATE control does not vary the sweep rate from 1 cps to 60 cps.

Check V121 (including neon lamp E101, mounted under the chassis).

No signal pips appear on the screen. Marker pips do not appear. Zero-frequency pip does not appear when CENTER FREQUENCY is set to 0 (may require adjustment of A and/or S BAL).

Check input stage (V101, V102, V103), balanced modulator (V104, V105), if stages (V106, V107, V108, V109, V110, V111), and sweeping oscillator (V116, V117, V118, V119). Use stage gain chart to help isolate failure.

## SYMPTOM

## CORRECTIVE MEASURES

Zero-frequency pip cannot be balanced.

Adjust C131 per V-2b(3).  
Check V104, V105.

No signal pips appear on crt screen. Zero-frequency pip appears when CENTER FREQUENCY is set to 0 (may require adjustment of A and/or S BAL).

Check connections between signal source and input to SPA-3. Check that attenuators, SWEEP WIDTH, and CENTER FREQUENCY are correctly set for level and frequency of input signals.  
Check V101, V102, V103.

Marker pips do not appear on crt screen. Signal pips do appear.

Check V115 (including Y104).

Insufficient signal sensitivity.

Check signal channel from crt to input (V123, V114, V112A, V111, V110, V109, V108, V107, V106, V105, V104, V103, V102, V101). Check sweeping oscillator output V119A.

LIN amplitude scale calibrations incorrect.

Check V112A.

LOG amplitude scale calibrations incorrect.

Check V111, V112A.

PWR amplitude scale does not function correctly.

Check V113.



## SYMPTOM

## CORRECTIVE MEASURES

The pip height of a constant amplitude signal varies more than  $\pm 10\%$  as the frequency is varied from 200 cps to 15 mc (to 25 mc with the SPA-3/25) with AMPLITUDE SCALE set to LIN.

Check V101, V102, V103, V104, V105.  
Check V118, V119.

INPUT ATTENUATOR, STEP functions incorrectly.

Check resistors and capacitor associated with switch S101.  
Check V101.

INPUT ATTENUATOR, CONTINUOUS has insufficient range.

Check V101, V102.  
Redetermine value of R123 per V-2b(2).

Switching IF ATTEN from 0 DB to 20 DB does not provide 20 db of attenuation.

Reset IF ATTEN ADJ for 20 db of attenuation.

SWEEP WIDTH and CENTER FREQUENCY dial calibrations incorrect.

Check V116, V117, V118, V119.

SWEEP WIDTH dial calibrations incorrect.  
CENTER FREQUENCY dial correct.

If sweep width insufficient and baseline too short, check V121 (including neon lamp E101, mounted under the chassis). Reset LINE SIZE, H POS, and CF BAL per V-2b(8).

Reset SWEEP LIMIT control and/or R342 (SPA-3/25 only) per V-2b(6).

Check V117, V118.

## SYMPTOM

Sweep width changes more than  $\pm 15\%$  as CENTER FREQUENCY control is changed from 0 to 13.5 mc (to 23.5 mc in the case of SPA-3/25).

CENTER FREQUENCY dial calibrations incorrect. SWEEP WIDTH dial correct.

Resolution poor.

Range of resolution incorrect. (If bandwidth cannot be made broad enough.)

## CORRECTIVE MEASURES

Check the gearing associated with the CENTER FREQUENCY control (variable capacitor). If this gearing has loosened, see V-4d(1).

Redetermine value of R341 per V-2b(9) (SPA-3).

Redetermine values of R343 and R344 per V-2b(10) (SPA-3/25).

Check V118.

Adjust L129 and OSC TRIMMER per V-2b(7).

Check crystals Y102, Y103.

NOTE: If it is necessary to replace the crystals, the replacement crystals should be obtained in matched pairs from Panoramic Radio Products, Inc.

Check V108 and V109B.

Realign crystal-filter circuits per V-2b(4).

### b. VOLTAGE-RESISTANCE CHARTS.

The charts were made with the Analyzer, Power Supply and Constant-Voltage Transformer interconnected for normal operation.

Unless otherwise specified, all voltage and resistance values were taken between the indicated point and chassis ground. All readings were made with an RCA VTVM Model WV-77B.

The following front-panel control settings were used:

SWEEP WIDTH ----- 3 MC  
CENTER FREQUENCY ----- 0  
IF BANDWIDTH ----- MAX  
AMPLITUDE SCALE ----- LIN  
IF ATTEN ----- 20 DB  
INPUT ATTEN ----- 0 DB  
MARKER ----- ON (largest pip full scale)  
VIDEO FILTER ----- OUT  
SWEEP RATE ----- 30 CPS

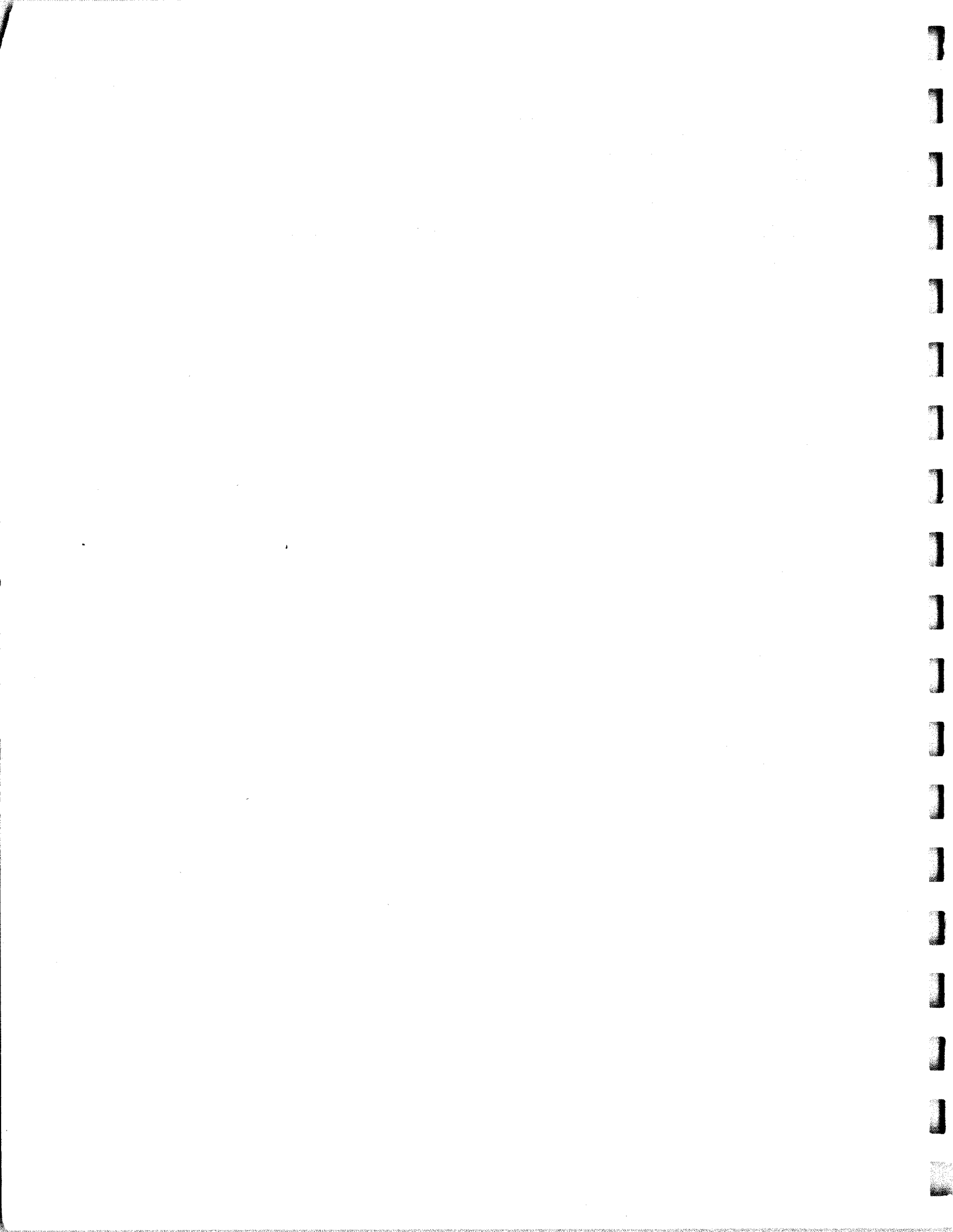





c. STAGE GAIN CHART.

The stage gain chart is used as a standard to check the gain of each stage when troubleshooting.

Set the front-panel controls as follows:

|                       |       |      |
|-----------------------|-------|------|
| SWEEP WIDTH Dial      | ----- | 3 MC |
| CENTER FREQUENCY Dial | ---   | 2 MC |
| IF BANDWIDTH          | ----- | MAX  |
| IF ATTEN              | ----- | X1   |
| AMPLITUDE SCALE       | ----- | LIN  |
| INPUT ATTEN (CONT)    | ----- | 0 DB |
| INPUT ATTEN (STEP)    | ----- | 0 DB |
| VIDEO FILTER          | ----- | OFF  |

The stage gain chart was made using a Measurements Corporation Standard Signal Generator, Model 82, with a Microlab 50-72 ohm matching pad and RG59/U coaxial cable terminated with 75 ohms. This is illustrated in Figure V-1.

Unless otherwise indicated, the listed input voltages are required for full scale deflection on the screen of the Spectrum Analyzer.

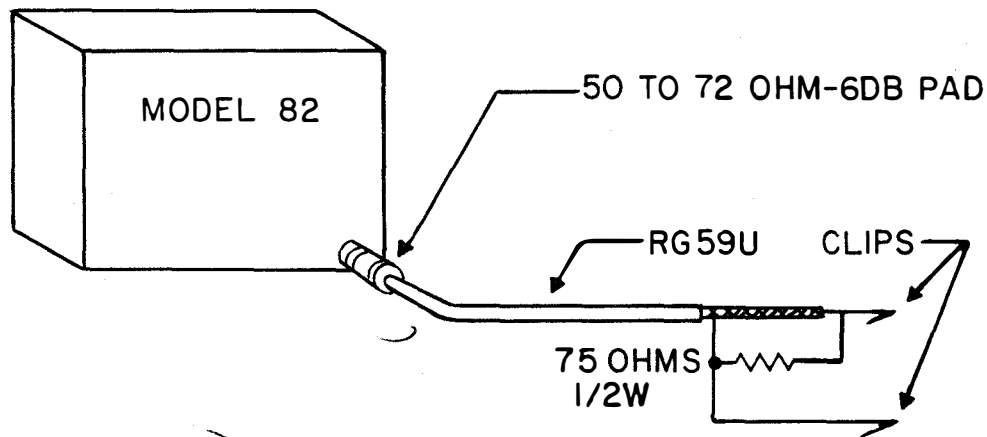

Figure V-1. Stage Gain Measurement Circuit.

For INPUT measurement, use RG59/U cable with BNC Type connectors at each end.

| CIRCUIT<br>REF SYM | TYPE       | PIN | FREQ   | INPUT VOLTAGE |
|--------------------|------------|-----|--------|---------------|
| V101               | 6J4(Input) | 1   | 2 mc   | 20 uv         |
| V103               | 6J6        | 5   | 2 mc   | 600 uv ✓      |
| V103               | 6J6        | 6   | 2 mc   | 120 uv ✓      |
| V104               | 5879       | 1   | 2 mc   | 400 uv ✓      |
| V105               | 5879       | 1   | 2 mc   | 500 uv ✓      |
| V104               | 5879       | 1   | 32 mc  | 120 uv        |
| V105               | 5879       | 1   | 32 mc  | 90 uv         |
| V106A              | 6AW8A      | 7   | 32 mc  | 60 uv         |
| V107               | 6BE6       | 7   | 32 mc  | 500 uv        |
| V107               | 6BE6       | 7   | 2.7 mc | 1400 uv ✓     |
| V108               | 6AB4       | 6   | 2.7 mc | 4.5K uv ✓     |
| V109A              | 6AW8A      | 7   | 2.7 mc | 1.4 K uv ✓    |
| V109B              | 6AW8A      | 2   | 2.7 mc | 11 K uv ✓     |
| V110               | 6CB6       | 1   | 2.7 mc | 3.5 K uv ✓    |
| V111               | 6AV6       | 1   | 2.7 mc | 150 K uv ✓    |
| V112               | 12AU7      | 7   | D. C.  | -7 volts      |
| V114               | 12AU7      | 2   | D. C.  | -6.7 volts    |
| V114               | 12AU7      | 1   | D. C.  | +135V*        |
| V114               | 12AU7      | 6   | D. C.  | +78V*         |
| V114               | 12AU7      | 7   | D. C.  | +16V*         |

\* D. C. voltages for -7 volts. Input at pin 7 of V112.



V-2. TOUCH-UP ALIGNMENT.

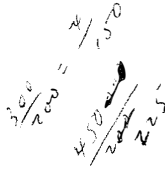

CAUTION: These adjustment should not be attempted unless suitable instruments and sufficiently skilled, experienced personnel are available.

This section indicates adjustments that may be needed when tubes or their associated components age or are changed. The chart indicates what to look for. It does not imply that any or all of the adjustments need be made. When a tube or associated component is changed, check the equipment operation before any adjustments are attempted in order to determine need for adjustment. Before any adjustments of chassis controls are made, the procedure should be read to determine the expected result. Wherever possible, the equipment should then be checked to see if it is already providing the desired result. Only if the equipment does not yield the desired result should the adjustment be made.

Equipment requirements are listed in the introductory paragraphs of V-4.

Before beginning any touch-up alignment, follow the interconnection and adjustment procedures outlined in II-3 and II-4 a, b, c, d. Allow at least a half hour warm-up period. After the warm-up period, connect a voltmeter (whose accuracy is known to be  $\pm 3\%$  or better at 250 volts) to the +250 V TEST pin jack on the rear apron of the PS-19 and, if necessary, adjust the +250 V ADJUST chassis control of the PS-19 for a B+ reading on the voltmeter of +250 volts dc.

a. Guide to Adjustment.

Analyzer Section.

| REFERENCE SYMBOL | TUBE TYPE                      | REQUIRED PROCEDURE        |
|------------------|--------------------------------|---------------------------|
| V101             | 6J4 (SPA-3)<br>6BQ7A(SPA-3/25) | Redetermine R123, IF GAIN |
| V102             | 6J4(SPA-3)<br>6CB6(SPA-3/25)   | Reset IF GAIN             |
| V103             | 6J6                            | Reset IF GAIN             |
| V104<br>V105     | 5879<br>5879                   | Reset C131,<br>IF GAIN    |
| V106             | 6AW8A                          | Reset IF GAIN             |

| REFERENCE SYMBOL | TUBE TYPE | REQUIRED PROCEDURE  |
|------------------|-----------|---|
| V107             | 6BE6      | Reset IF GAIN   |
| V108             | 6AB4      | Reset IF GAIN, L111   |
| V109             | 6AW8A     | Reset IF GAIN, L117   |
| V110             | 6CB6      | Reset IF GAIN   |
| V111             | 6AU6      | Reset 20 DB LOG ADJUST and 0 DB LOG ADJUST<br>Reset IF GAIN   |
| V112             | 12AU7     | Check LIN and LOG screen calibrations   |
| V113             | 12AT7     | Redetermine R287, R297  |
| V114             | 12AU7     | Reset V POS and check crt screen amplitude calibrations   |
| V115             | 12AX7     | None  |
| V116             | OA2       | None  |
| V117             | 12BY7     | If the voltage at J115 is not 0.95 volts, reset BIAS.<br>Reset SWEEP LIMIT and/or R342 (SPA-3/25)         |
| V118             | 6BK7      | Check SWEEP WIDTH and CENTER FREQUENCY dial calibrations<br>Reset OSC TRIMMER (C263) and L129 if required |
| V119             | 6J6       | Reset IF GAIN   |
| V120             | 12AT7     | None  |
| V121             | 6U8       | Reset LINE SIZE, CF BAL   |
| V122             | 12AU7     | Reset H POS   |
| V123             | 5ADP7     | Reset BRILLIANCE, FOCUS, V POS, H POS, and IF GAIN<br>Check crt screen amplitude calibrations             |

## Power Supply Section

| REFERENCE SYMBOL | TUBE TYPE | REQUIRED PROCEDURE   |
|------------------|-----------|--|
| V1               | 5U4       |  |
| V2               | 6146      |  |
| V3               | 6146      |  |
| V4               | 12AX7     | Check for +250v at J5  |
| V5               | 12AX7     | Reset +250v ADJ. It is important to use a voltmeter which is known to be accurate to $\pm 3\%$ . |
| V6               | 5651      |  |
| V7               | 5651      | None   |

### b. Adjustment Procedures.\*

#### (1) IF GAIN.

If the equipment sensitivity is incorrect adjust the IF GAIN control using the following procedure.

Set the CENTER FREQUENCY dial to 2 MC and the SWEEP WIDTH dial to 3 mc. Set the other front-panel controls as listed in paragraph II-4k. Connect a 2-mc, 20-uv signal to the analyzer INPUT. Set IF GAIN for a full-scale pip on the crt screen.

#### (2) R123.

If the INPUT ATTENUATOR, CONTINUOUS control does not have at least a 20 db range change the value of R123 according to the following procedure:

Set the SWEEP WIDTH dial to 3 mc and the CENTER FREQUENCY dial appropriate to the input signal. Set the other front-panel controls as listed in paragraph II-4k. Connect an input signal to the analyzer INPUT and adjust the signal level to obtain a full-scale pip on the crt screen. Increase the input level 10 times. Turn INPUT ATTENUATOR, CONTINUOUS completely clockwise. Adjust the value of R123 for a less than full-scale pip on the crt screen.

---

\* The functions of the service controls and factory-adjusted components are given in section V-3.

(3) C131.

If good suppression of the zero-frequency pip cannot be obtained, reset C131 in accordance with the following procedure.

Set the CENTER FREQUENCY dial to 0 and the other front-panel controls as listed in paragraph II-4a.

Set A BAL and S BAL to the center of their rotational range. Adjust C131 for best suppression of the zero-frequency pip. Adjust A BAL and S BAL for best suppression of the zero-frequency pip. Trim C131, A BAL, and S BAL for best suppression of the zero-frequency pip.

Set IF ATTEN to 0 DB and trim C131, A BAL, and S BAL for best suppression of the zero-frequency pip.

(4) L111, L117.

If resolution range is unsatisfactory (if bandwidth cannot be made broad enough), adjust L111 and/or L117 in accordance with the following procedure.

Connect a 2-mc signal to the analyzer-section INPUT. Set SWEEP WIDTH to 3 mc and CENTER FREQUENCY for a centered 2-mc pip. Adjust SWEEP WIDTH, while maintaining the pip at the center of the screen with the CENTER FREQUENCY control, so that the base of the pip occupies approximately 1/3 of the baseline.

Remove crystal Y102. Trim L117 for minimum deflection and broadest pip, adjusting the INPUT ATTENUATOR and SWEEP WIDTH controls to keep the sides of the pip visible. If the pip moves across the screen, keep it centered by use of the CENTER FREQUENCY control or by shifting the input frequency. Note that when the coil is correctly set, a condition of minimum height and broadest pip will be achieved. As the coil is tuned away from the correct position, the pip will increase in amplitude, become narrower, and shift horizontally. After L117 is correctly set, replace crystal Y102.

Remove crystal Y103 and repeat the above procedure using L111 in place of L117. When L111 is correctly set, replace crystal Y103.

(5) 20 DB LOG ADJUST, 0 DB LOG ADJUST.

If the logarithmic amplitude scale calibrations are incorrect, adjust 20 DB LOG ADJUST and 0 DB LOG ADJUST in accordance with the procedures of paragraph V-4f.

(6) SWEEP LIMIT and R342 (SPA-3/25).

With the SPA-3, if the sweep width is not 3 mc when the SWEEP WIDTH dial is set for 3 mc, reset the SWEEP LIMIT control. With the SPA-3/25, if the sweep width is not 3 mc when the SWEEP WIDTH dial is set for 3 mc, reset the SWEEP LIMIT control on the HI Band and R342 on the LO Band. Use the marker pips to determine the sweep width as indicated in paragraph II-4g.

(7) OSC TRIMMER (C263), L129.

If the CENTER FREQUENCY dial calibrations are incorrect (be sure that the Center Frequency VERNier is correctly set per paragraph III-3c before finding fault with the dial), adjust OSC TRIMMER (C263) and L129 in accordance with the procedures of subparagraphs V-4d(3), (4), (5) and (6). Before starting, be sure that the BIAS control is set for 0.95 volts at the BIAS TEST jack on the rear apron of the analyzer-section chassis and that the Center Frequency VERNier is in the center of its rotational range.

(8) LINE SIZE, CF BAL.

If the size of the baseline is not correct and/or if it is not centered after H POS is adjusted per paragraph II-4g, adjust LINE SIZE and if necessary CF BAL in accordance with the procedures of paragraph V-4a(3).

(9) R341 (SPA-3).

If the sweep width changes more than  $\pm 15\%$  as the CENTER FREQUENCY control is changed from 0 to 13.5 mc, redetermine the value of R341 (after first determining that the gearing associated with the CENTER FREQUENCY control has not loosened). With the SWEEP WIDTH dial set for a 3-mc sweep width, check the sweep width at a 1.5-mc and 13.5-mc center frequency and at several intermediate points using the frequency markers. Choose a value for R341 that results in least change in sweep width over the range of the CENTER FREQUENCY control.

(10) R343, R344 (SPA-3/25).

R343 and R344 serve the same function and are set for the same reasons, using the same procedures as are indicated for R341 in subparagraph (9) above. First adjust R343 for the LOBand and then R344 for the HI Band.

### V-3. SERVICE CONTROLS AND FACTORY-ADJUSTED COMPONENTS.

The controls and components described in this section are for adjustment only in maintenance and service of the equipment. They should not be adjusted by operating personnel but should be left to experienced service personnel and should only be adjusted in accordance with the procedures given in sections V-2 and V-4.

a. IF ATTENUATOR ADJUST, R181.

This control is used to set the IF ATTEEN switch circuitry to provide 20 db of attenuation.

b. IF GAIN, R187.

This control is used to adjust the gain of V106A for correct equipment standard sensitivity.

c. 20 DB LOG ADJUST, R261 and 0 DB LOG ADJUST, R279.

These controls are used to adjust the last if stage and the detector circuit to provide proper LOG amplitude screen calibration.

d. BIAS, R353.

This control is used to set the current flow through the Vari-L inductor (L127) such that the center frequency-versus-temperature drift of the sweeping oscillator is at a minimum.

e. CF BAL, R411.

This control is used to obtain a zero average dc level of the sawtooth voltage, thereby permitting correct baseline centering.

f. LINE SIZE, R415.

This control is used to obtain correct crt baseline size.

g. EXT. LINE SIZE, R417.

This control is used to obtain correct crt baseline size when an external sweep source is used.

h. SWEEP LIMIT, R421; R342 (SPA-3/25).

On the SPA-3, the SWEEP LIMIT control is used to set the maximum sweep width of the equipment. On the SPA-3/25, the control is used to set the maximum sweep width for the LO Band and R342 is used to set the maximum sweep width for the HI Band.

i. R123.

This resistor is adjusted such that the CONTINUOUS INPUT ATTENUATOR control provides at least 20 db attenuation.

j. R137, R142 (SPA-3/25).

R137 is part of the frequency-compensation network of the input cascoded amplifier (V101, V102 in the SPA-3 and V101A, V101B in the SPA-3/25). R142 is part of the frequency-compensation network of the SPA-3/25 Wide-Band Input Amplifier.

k. R228, R245.

These resistors are adjusted for an optimum shape of the amplitude-versus-frequency response curve of the 2.7-mc if amplifier section.

l. R263.

This resistor is used to provide adequate range for the 20 DB LOG ADJUST control.

m. R341 (SPA-3); R343 and R344 (SPA-3/25).

These resistors are adjusted to minimize variation in sweep width as the center frequency is changed.

n. C107, C115, C117.

These variable capacitors are part of frequency compensation networks of the input stage of the equipment. C107 is part of the input cascoded amplifier (V101, V102). C115 and C117 are part of the paraphase amplifier (V103).

o. C131.

This variable capacitor is used to provide correct phase balance between the outputs of the two sections of the balanced modulator (V104, V105).

p. C167.

This variable capacitor is the neutralizing capacitor for crystal Y102.

q. C179.

This variable capacitor is part of the tuned-plate circuit of the first 2.7-mc tuned if amplifier (V109A).

r. C185.

This variable capacitor is the neutralizing capacitor for crystal Y103.

s. C263, OSC TRIMMER, C270 (SPA-3/25).

Variable capacitor C263 is used in conjunction with L129 to set the range of the CENTER FREQUENCY control. The capacitor is used to set the 13.5-mc end of the dial on the SPA-3 and to set the high frequency end of the dial on the LO Band on the SPA-3/25. C270 is used to set the 23.5-mc end (HI Band) of the SPA-3/25 dial.

t. L109.

This variable inductance is part of the tuned circuit associated with the 29.3-mc crystal oscillator (V106B).



u. L111.

This variable inductance is the load coil for crystal filter Y102.

v. L117.

This variable inductance is the load coil for crystal filter Y103.

w. L129.

This variable inductance is used in conjunction with the OSC TRIMMER (C263) to set the range of the CENTER FREQUENCY control. The inductor is used to set the zero-frequency end of the dial.

#### V-4. COMPLETE FIELD ALIGNMENT PROCEDURE.

This is a complete field alignment procedure. It is only under the most unusual circumstances that this procedure will have to be used in its entirety. Most of the alignment problems encountered in the field can be solved by using the applicable adjustment techniques given in Section V-2. The complete alignment should not be attempted unless suitable instruments and sufficiently skilled, experienced personnel are available.

Before making any adjustment, the procedure should be read to determine the expected result. Wherever possible, the equipment should then be checked to see if it is already providing the desired result. Only if the equipment does not yield the desired result should the adjustment be made.

The following equipment is required:

1. Well calibrated, low-harmonic content signal generators (with accurate internal or external level indicators), to cover the frequency range of 200 cps to 15 mc (to 25 mc in the case of SPA-3/25).
2. A voltmeter accurate to  $\pm 3\%$  at 250 v dc.

Before beginning the alignment, follow the interconnecting procedure given in II-3. Allow at least a half hour warm-up period. After the warm-up period, connect a voltmeter (whose accuracy is known to be  $\pm 3\%$  or better at 250 volts) to the +250 V TEST pin jack on the rear apron of the PS-19 and, if necessary, adjust the +250 V ADJUST chassis control of the PS-19 for a B+ reading on the voltmeter of +250 volts dc.

a. Baseline Adjustment.

(1) Adjust FOCUS, BRILLIANCE, and ASTIGMATISM (located on analyzer-section chassis) as required for a suitable trace. FOCUS and ASTIGMATISM should be set for a clear, sharp, uniform trace. BRILLIANCE should be set at the minimum point of suitable visibility. Do not use the BRILLIANCE control to compete with external light falling on the crt screen but rather shield the screen from the external light. If the baseline trace does not coincide with the baseline of the calibrated screen, a suitable adjustment of the V POS control should be made. If there is a lack of parallelism, rotate the crt in accordance with the procedures given in II-4c.

(2) Adjust the SWEEP RATE control so that the sweep rate of the crt beam is 30 cps and set the CAL-SYNC SEL to the LINE position. (See paragraph II-4e.) *Page 25*

(3) Adjust the LINE SIZE, CF BAL, and H POS controls in accordance with the following procedure.

(a) Set H POS to the center of its rotational range.

(b) Set LINE SIZE such that the baseline length is approximately that of the calibrated portion of the crt screen. If the line is not centered, use the CF BAL control to obtain a centered line. (*INSIDE*)

(c) Set CENTER FREQUENCY to 10 MC, SWEEP WIDTH to 3 mc, IF ATTENUATOR to 0 DB, and AMPLITUDE SCALE to LIN. Switch on the internal marker by rotating the MARKER AMPLITUDE control clockwise. Adjust the control for a convenient height of marker presentation. The 10-mc marker pip should be at or near the center of the screen. Gradually reduce SWEEP WIDTH to minimum, maintaining the 10-mc pip at the center of the screen with the CENTER FREQUENCY control. Return to 3-mc sweep width and adjust H POS until the top of the pip coincides with the center vertical line on the screen.

(d) Trim LINE SIZE and CF BAL until a centered line of the correct length is obtained. The length of the baseline is correct if it extends at least 1/8 inch beyond the calibrated portion of the crt screen at all sweep rates and does not extend past the edges of the crt screen at least at one sweep rate.

b. IF Alignment.

NOTES: 1. It may be necessary to adjust the input signal levels to keep the baseline trace on the screen.

2. All coils are tunable from the top of the chassis. Bottom core adjustments are made by passing the black end of the supplied Walsco #2543 alignment tool through the hollow top core until the end of the tool engages the bottom core. Care must be taken, when removing the tool, not to disturb the setting of the top core. For this reason, wherever possible, it is better to adjust the bottom core before the top core is adjusted. The top core can be adjusted with either the black or blue end of the tool.

(1) Set AMPLITUDE SCALE to LIN. Set IF ATTEN to 0 DB. Set CENTER FREQUENCY to 2 MC. Set SWEEP WIDTH to 0. Set IF BANDWIDTH to MAX. Set VIDEO FILTER to OFF. Set SWEEP RATE to 30 cps. Set IF GAIN to 3/4 maximum clockwise rotation.

(2) Couple a 2.7-mc signal through a 0.01-uf capacitor to pin 1 of V111. Adjust the top and bottom cores of T106 for a maximum baseline rise. The 0.01-uf capacitor should also be used in the following steps.

(3) Connect the 2.7-mc signal to pin 1 of V110. Adjust the top and bottom cores of T105 for a maximum baseline rise.

(4) Connect the 2.7-mc signal to pin 7 of V107. Adjust the top and bottom cores of T104 for a maximum baseline rise. Adjust C179 for a maximum baseline rise.

(5) Couple a 32.0-mc signal through a 0.01-uf capacitor to pin 7 of V106. Adjust the top and bottom cores of T103 for a maximum baseline rise.

(6) Connect the 32.0-mc signal to pin 1 of V104. Adjust the bottom cores of T102 and T101 for maximum baseline rise.

c. Adjustment of Crystal-Filter Circuits.

NOTE: If it is necessary to replace crystals, the replacement crystals should be obtained in matched pairs from Panoramic Radio Products, Inc.

- (1) Set the SWEEP WIDTH control to 3 mc.
- (2) Connect a 2-mc signal to the analyzer INPUT connector.
- (3) Set the CENTER FREQUENCY control so that the 2-mc pip is in the center of the screen. Trim the top and bottom cores of T106, T105, T104 and T103 for maximum pip deflection. Trim C179 and the bottom cores of T102 and T101 for maximum pip deflection.
- (4) Tune L109 for maximum pip deflection.
- (5) Adjust the SWEEP WIDTH control, while maintaining the pip at the center of the screen with the CENTER FREQUENCY control, so that the base of the pip occupies approximately 1/3 of the baseline.
- (6) Remove crystal Y102. Adjust the INPUT ATTENUATOR, STEP to any convenient position other than 0 DB. Set the signal generator output level for a full-scale pip. Trim C185 to remove the rejection slot as follows. Rotate C185 through 360 degrees noting the change in pip shape. At some point of rotation, the pip should approximate the shape shown in Figure V-2a or its mirror image.

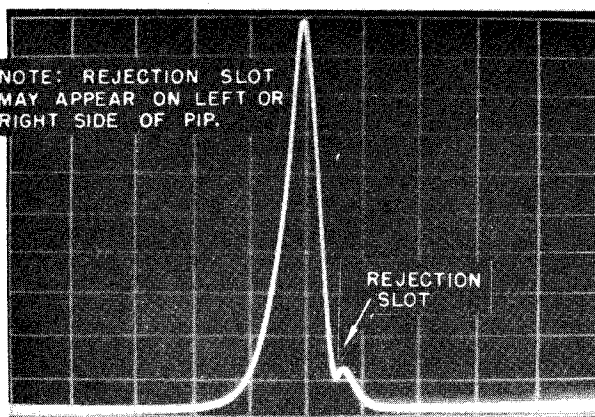

a. Illustration of Rejection Slot

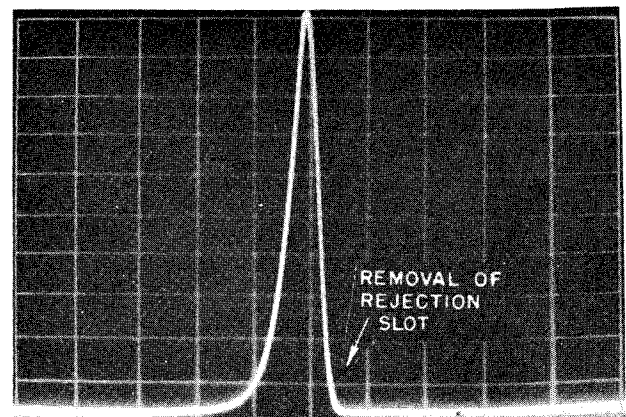

b. Illustration of Complete Rejection Slot Removal

Figure V-2. Crystal Rejection Slot Removal

As rotation is continued, the rejection slot should sharpen and disappear into the side of the pip. Continued rotation should cause the rejection slot to appear on the other side of the pip. Reverse the rotation and choose a point at which pip symmetry is best and no rejection slot is present. This is illustrated in Figure V-2b. This point should be approximately halfway between the two positions at which the rejection enters the pip from the sides. Reset the INPUT ATTENUATOR, STEP for 20 db less attenuation thereby causing the pip to go over full scale. If necessary, adjust SWEEP WIDTH so that the sides of the pip go into the baseline. Trim C185 for absence of rejection slot and best pip symmetry.

- (7) Adjust the INPUT ATTENUATOR as necessary to give a full-scale pip.
- (8) Adjust L117 for minimum deflection and broadest pip, adjusting the INPUT ATTENUATOR and SWEEP WIDTH controls to keep the sides of the pip visible. If the pip moves across the screen, keep it centered by use of the CENTER FREQUENCY control or by shifting the input frequency. Note that when the coil is correctly adjusted, a condition of minimum height and broadest pip will be achieved. As the coil is tuned away from the correct position, the pip will increase in amplitude, become narrower, and shift horizontally.
- (9) Repeat steps 6, 7 and 8.
- (10) Replace crystal Y102.
- (11) Remove crystal Y103.
- (12) If necessary, readjust the INPUT ATTENUATOR for a full-scale pip.
- (13) Repeat steps 6 through 9 using C167 and L111 in place of C185 and L117.
- (14) Replace crystal Y103.
- (15) Adjust controls for a full-scale broad pip as in step 5.
- (16) Adjust the IF BANDWIDTH control counterclockwise until optimum resolution is obtained. See subparagraph III-4c(2)(e) and Figure III-3.
- (17) Touch-up the following transformers, coils, and capacitor for maximum pip height: T106, T105, C179, T104, T103, T102, T101 and L109.

d. Oscillator Alignment.

(1) If the gear coupling between the CENTER FREQUENCY capacitor and SWEEP WIDTH TRACK potentiometer has been disturbed\*, proceed as follows: With the power off, disengage dial spacer and gear by removing CENTER FREQUENCY knob and fiducial and pulling the dial forward. Turn SWEEP WIDTH TRACK to the maximum counterclockwise position. Turn the CENTER FREQUENCY capacitor counterclockwise until the plates are fully meshed. Then turn the capacitor about 5 degrees further. Engage dial spacer and gear. Turn power on, set SWEEP WIDTH to 3 mc. Turn CENTER FREQUENCY control counterclockwise and note how far the zero-frequency pip moves to the right before it reverses direction. The travel to the right should be for one horizontal screen division. If it is not, turn power off and disengage dial gear and spacer. If the travel is greater than one division, turn the capacitor slightly clockwise. If it is less, turn the capacitor slightly counterclockwise.

(2) Adjust the BIAS control for 0.95-volts dc as measured at BIAS TEST jack on the rear apron of the analyzer-section chassis.

(3) Turn CENTER FREQUENCY dial to 0. (If the equipment is an SPA-3/25, be sure that it is set for the LO Band.) Set the SWEEP WIDTH dial to 0.5 mc. Adjust L129 (on top of oscillator sub-chassis) so that zero-frequency pip is in the center of the screen.

(4) Connect a 13.5-mc<sup>+</sup> signal to the analyzer input. Turn CENTER FREQUENCY dial to 13.5 MC. (If the equipment is an SPA-3/25, be sure that it is set for the LO Band.) Adjust C263 (on top of oscillator sub-chassis) so that the 13.5-mc<sup>+</sup> pip is in the center of the screen.

(5) Repeat steps 3 and 4 until "0" and "13.5"<sup>+</sup> are calibrated correctly.

(6) (SPA-3/25 only) Connect a 23.5-mc signal to the SPA-3/25 input. Set the CENTER FREQUENCY dial to 23.5 MC. (Be sure the equipment is set for the HI Band.) If necessary, change the value of C270 such that the 23.5-mc pip is in the center of the screen.

---

\* This will happen only if the swept oscillator sub-chassis is removed and/or the gearing associated with the CENTER FREQUENCY control loosens.

+ Use highest frequency calibrated on LO Band of SPA-3/25.

(7) The CENTER FREQUENCY dial calibrations can be checked by using the internal markers. See paragraph II-4j. Turn on the markers by rotating the MARKER AMPLITUDE control clockwise. If required, construct an error chart for the dial or calibrate a new dial.

(8) With the SWEEP WIDTH dial set to 3 mc, center a 10-mc pip on the screen (use a 20-mc pip if the equipment is an SPA-3/25). Using the markers as an indication, set the SWEEP LIMIT control so that the sweep is 3 mc.. The sweep is 3 mc when the third marker pip to the left and to the right of the 10-mc pip (20-mc pip if SPA-3/25) are within  $\pm 1/2$  division from the left and right edge of the calibrated crt screen rectangle. If the equipment is an SPA-3/25, after the SWEEP LIMIT control is set on the HI BAND, set R342 for 3-mc sweep width at a 10-mc center frequency (HI Band).

(9) Check the SWEEP WIDTH dial calibrations per paragraph II-4i. If required, construct an error chart for the dial or calibrate a new dial.

e. Flatness Adjustments.

Be sure that the signals used are connected correctly to the spectrum analyzer. See paragraph II-4d.

(1) Connect a 20-uv, 2-mc signal to the analyzer-section input. Set all attenuators to minimum attenuation. Set CENTER FREQUENCY to 2 MC. Set SWEEP WIDTH to 3 mc. Set AMPLITUDE SCALE switch to LIN. Adjust IF GAIN so that the 20-uv, 2-mc pip is of full-scale amplitude.

(2) Connect a 20-uv, 15-mc signal (23.5-mc for SPA-3/25) to the input connector. Tune C107, C115 and C117 for maximum pip height and then for best flatness.

(3) Check amplitude flatness over the frequency range of the equipment. If the high frequency end drops off excessively, slightly reduce the values of Factory Adjust resistor R137 (and, in the SPA-3/25, R142) and repeat steps 1 and 2. If the high frequency end rises excessively, slightly increase the value of Factory Adjust resistor R137 (and, in the SPA-3/25, R142) and repeat steps 1 and 2.

f. Adjusting the LIN-LOG Amplitude Scales and Standard Sensitivity.

(1) Set the CENTER FREQUENCY dial to 2 MC, the SWEEP WIDTH dial to 0.5 mc, the IF ATTEN to 0 DB, and the AMPLITUDE SCALE to LIN. Connect a 2-mc signal to the analyzer-section input and adjust its level for a full-scale crt deflection.

(2) Set AMPLITUDE SCALE to LOG.

(3) Adjust 20 DB LOG ADJUST for a 20-db pip height on the DB amplitude scale of the crt screen.

(4) Increase the input signal amplitude 10 times.

(5) Adjust 0 DB LOG ADJUST for a full-scale pip.

(6) Repeat steps 1 through 5 until the LOG amplitude scale is correct.

(7) Set AMPLITUDE SCALE to LIN. Adjust IF GAIN so that a 20-uv, 2-mc pip is of full-scale amplitude.

(8) Check the calibration points on the crt amplitude scales and if necessary construct an error chart or calibrate a new crt screen.

g. Adjusting the IF ATTEN.

(1) Set the IF ATTEN to 0 DB, the CENTER FREQUENCY dial to 2 MC, the SWEEP WIDTH dial to 0.5 mc, and the AMPLITUDE SCALE to LIN. Connect a 2-mc signal to the analyzer-section input and adjust its level for a full-scale crt deflection.

(2) Set the IF ATTEN switch to 20 DB.

(3) Increase the input signal amplitude 10 times.

(4) Adjust IF ATTEN ADJ for a full-scale pip.



*Handwritten scribble*

V-5. FINAL TEST PROCEDURE.

The Model SPA-3 should be tested after it has been repaired. Repaired equipment, meeting the standards indicated in the test procedures of this section, will furnish uniformly satisfactory operation.

a. Mounting, Interconnection, and Initial Adjustments.

Mount and interconnect the equipment in accordance with sections II-2 and *Page 17-23* II-3. Perform the initial adjustments given in section II-4, paragraphs a, b, c, and d. *Page 23-25*

b. Sweep Rate.

Turn the SYNC AMP control completely counterclockwise. Set the CAL-SYNC SEL to the CAL position. Set the SWEEP RATE control completely clockwise. Turn SYNC AMP clockwise and if necessary trim the SWEEP RATE control until one cycle of sine wave appears stationary on the crt screen. This demonstrates that the maximum sweep rate is at least 60 cps. Turn SWEEP RATE completely counterclockwise. Using a watch, count the number of sweeps that occur in 20 seconds. There should be 20 or fewer sweeps in 20 seconds demonstrating that the minimum sweep rate is one cps or less.

This test demonstrates that the range of the SWEEP RATE control is at least 1 to 60 cps.

c. Sensitivity.

Adjust the sweep rate to approximately 30 cps in accordance with paragraph II-4e.

Set the front-panel controls as follows:

|                                |                             |
|--------------------------------|-----------------------------|
| AMPLITUDE SCALE -----          | LIN                         |
| IF ATTEN -----                 | 0 DB                        |
| INPUT ATTENUATOR, CONTINUOUS - | Completely counterclockwise |
| INPUT ATTENUATOR, STEP -----   | 0 DB                        |
| IF BANDWIDTH -----             | MAX                         |
| VIDEO FILTER -----             | OFF                         |
| SWEEP WIDTH -----              | 3 MC                        |

Connect a signal generator to the analyzer-section INPUT. Set the CENTER FREQUENCY dial and the signal generator to 2 mc. Set the generator level for a full-scale pip on the crt screen.

An approximately 20-microvolt input to the equipment indicates correct sensitivity.

Note that in the absence of a suitable signal generator, a rough check of sensitivity correctness is the presence of noise ("grass") on the screen when INPUT ATTENUATOR, STEP is set to 80 DB and INPUT ATTENUATOR, CONTINUOUS is set to 0 DB.

d. IF ATTENUATOR.

With the sweep rate set to 30 cps and the front-panel controls set as in paragraph "c" above, set the signal generator input for full-scale deflection on the crt and note the input amplitude. Set the IF ATTEN to 20 DB. Reset the signal generator input level for full scale deflection. Note the required level.

If the IF ATTEN control is working correctly, the generator input at 20 DB should be 9.8 to 10.2 times that at 0 DB.

e. INPUT ATTENUATOR, STEP and CONTINUOUS.

With the sweep rate set to 30 cps and the front-panel controls set as in paragraph "c" above, set the signal generator input for full-scale deflection on the crt and note the input amplitude. Set the INPUT ATTENUATOR to 20 DB, 40 DB, 60 DB and 80 DB, resetting and noting the generator level for a full-scale deflection on the crt at each position.

If the INPUT ATTENUATOR, STEP control is working correctly the level required at each position should be greater than that required at 0 DB by 20 DB  $\pm$  1 db, 40 DB  $\pm$  2 db, 60 DB  $\pm$  3 db, 80 DB  $\pm$  4 db, respectively.

Set the generator for full-scale deflection on the crt. Increase the generator input 10 times. Turn INPUT ATTENUATOR, CONTINUOUS completely counterclockwise.

If the INPUT ATTENUATOR, CONTINUOUS control is working correctly, the crt deflection should be full scale or less.

f. Balance.

Set the CENTER FREQUENCY dial to 0 and the other front-panel controls as in paragraph "c" above. At several sweep rates between 1 cps and 60 cps and several sweep widths between 0 and 3 mc it should be possible to cause the zero-frequency pip to go through a minimum point with the A BAL and S BAL controls.

g. Markers and CENTER FREQUENCY dial.

Set the INPUT ATTENUATOR, STEP to 80 DB and the other front-panel controls as in paragraph "c" above. Note that at higher frequencies, the IF ATTENUATOR must be set to 0 DB to obtain a suitable marker presentation. Set the CENTER FREQUENCY dial to 10 MC. Switch the internal markers on by rotating the MARKER AMPLITUDE control clockwise. Adjust the control for a convenient height of marker presentation. The 10-mc marker pip should be at or near the center of the screen. Gradually reduce SWEEP WIDTH noting the change in the 10-mc pip. If the top of the pip moves to either side of its original position as sweep width is reduced, adjust the CENTER FREQUENCY dial slightly to keep the pip at the center of the screen. Return to 3-mc sweep width and adjust H POS until the top of the pip coincides with the center vertical line (0 frequency calibration) on the screen. Marker pips should be present every 0.5 mc from 0.5 mc to 15 mc on the SPA-3 and to 25 mc on the SPA-3/25.

Check the CENTER FREQUENCY dial by setting the SWEEP WIDTH dial to 3 mc and then matching the CENTER FREQUENCY dial calibrations with the corresponding marker frequency starting with the CENTER FREQUENCY dial set to 0. The top of the pip should appear at or near the center of the screen. Be sure that the Center Frequency VERNIER is set such that the zero-frequency pip is at the center of the screen when the CENTER FREQUENCY dial is set to 0 MC.

h. SWEEP WIDTH Dial.

Set the INPUT ATTENUATOR, STEP to 80 DB and the other front-panel controls as in paragraph "c" above. Using the marker pips, check the SWEEP WIDTH dial calibrations corresponding to frequencies above 0.5 mc. Set the SWEEP WIDTH to 3 mc and CENTER FREQUENCY to 1.5 mc. Turn MARKER AMPLITUDE on and set it for a convenient amplitude of marker display. The zero-frequency pip should be at or near the -0.5 calibration mark of the SWEEP WIDTH FACTOR screen scale. (It may be necessary to adjust A BAL and/or S BAL to unbalance the equipment sufficiently to see the zero-frequency pip.) The sixth marker pip to the right of the zero-frequency pip should be at or near the +0.5 mark of the SWEEP WIDTH FACTOR scale. (Each pip being 0.5-mc apart, the sixth pip to the right of the zero-frequency pip corresponds to a frequency of 3 mc. Since SWEEP WIDTH is set for 3 mc, a 3-mc pip should fall at +0.5 ( $\pm 1/2$  division) when the zero-frequency pip falls at -0.5 ( $\pm 1/2$  division) on the SWEEP WIDTH FACTOR scale. Note that it may be necessary to adjust CENTER FREQUENCY to center this display of six marker pips plus the zero-frequency pip. Other SWEEP WIDTH dial calibrations in increments of 0.5 mc between 0.5 mc and 3 mc can be checked using the 0.5-mc-apart marker pips. For example, setting the CENTER FREQUENCY

dial for 1.75 mc and the SWEEP WIDTH dial for 0.5 mc, marker pips should appear at +0.5 and -0.5 on the SWEEP WIDTH FACTOR scale (approximately).

To check sweep widths narrower than 0.5 mc, an amplitude-modulated signal may be used. The modulating source should be set to a frequency equal to one-half the SWEEP WIDTH dial setting. The CENTER FREQUENCY dial should be set to the carrier frequency. The upper and lower sidebands may then be used to determine the actual sweep width. Note that in order to have suitable pips at narrow sweep widths it may be necessary to reduce the sweep rate and the IF bandwidth thereby improving resolution. Section III-4c contains a more extended discussion of narrow-band techniques.

i. Frequency Linearity.

With the SWEEP WIDTH dial set accurately for a 3-mc sweep width (use the markers) and the other front-panel controls set as in paragraph "c" above, center a convenient input pip on the screen. Change the input frequency in five steps of 300 kc above and below the frequency of the center pip. Each signal pip should fall within  $\pm 1/2$  a screen division of its appropriate screen marking if the frequency linearity is correct. Note that this test can be performed conveniently by using a harmonically rich 300-kc signal source to place 11 pips on the crt screen which are equally spaced in frequency.

j. Resolution.

Representative points on the resolution graph (Figure I-2) may be checked by using the following procedure.

- (1) Set the front-panel controls as indicated in paragraph "c" above.
- (2) Connect an fm signal generator to the analyzer input and set the CENTER FREQUENCY dial appropriate to the generator output.
- (3) Adjust the IF BANDWIDTH control for optimum resolution. (See III-4c(2)e and Figure III-5.)
- (4) Frequency modulate the signal generator carrier with a frequency-calibrated oscillator. (A range of approximately 200 cps to 30 kc is required to check the full range of resolution.)

(5) Adjust the fm signal generator and the modulating oscillator such that the carrier and the closest modulation product are both full-scale pips whose point of intersection is 50 per cent down from the top of the pips. The frequency setting of the modulating oscillator is the resolution of the SPA-3 or SPA-3/25.

k. Amplitude Response.

Set the front-panel controls as in paragraph "c" above. Set the SWEEP WIDTH dial to 3 mc and CENTER FREQUENCY dial to 0.5 MC. Set the generator frequency to 0.5 mc and adjust its level for a full-scale deflection on the crt. Be sure that the generator is connected in accordance with paragraph II-3d since mis-matching will effect amplitude response. If the Model PRB-1 is used, see "n" below. Maintaining a constant-amplitude input to the equipment, vary the frequency of the generator from 0.5 mc to 15 mc (to 25 mc with an SPA-3/25), maintaining the pip at the center of the crt screen with the CENTER FREQUENCY dial. The variation of pip amplitude should not be greater than  $\pm 10\%$

It usually is not necessary to check the amplitude response at the low-frequency end of the range since it is unusual for failure to occur at this end of the range. If failure is suspected, measurements have to be made at reduced sweep width, reduced sweep rate, and narrow if bandwidth. (See paragraph III-4d for narrow-band techniques.) Since adjustment of sweep width, sweep rate, and if bandwidth changes sensitivity, in order to measure amplitude-versus-frequency response down to 200 cps, it is necessary to correlate sensitivities at various sweep widths, sweep rates, and if bandwidths.

l. CRT Amplitude Scale.

Check the amplitude scales using a signal of variable and known amplitude and low distortion. The voltages given in these checks are approximate since the instrument measures relative amplitude rather than absolute amplitude. Any convenient fixed CENTER FREQUENCY and SWEEP WIDTH dial settings compatible with the generator frequency and pip readability may be used. Set the controls as follows:

|                                   |                             |
|-----------------------------------|-----------------------------|
| AMPLITUDE SCALE -----             | LIN                         |
| IF ATTEN -----                    | 0 DB                        |
| INPUT ATTENUATOR, CONTINUOUS ---- | Completely counterclockwise |
| INPUT ATTENUATOR, STEP -----      | 0 DB                        |
| IF BANDWIDTH -----                | MAX                         |
| VIDEO FILTER -----                | OFF                         |
| SWEEP RATE -----                  | 30 cps                      |

Adjust the generator level for a full-scale crt deflection. Switch AMPLITUDE SCALE to LOG. The pip amplitude should be in line with the 20 DB calibration dot on the left side of the calibrated crt scale. Change INPUT ATTENUATOR, STEP to 20 DB. Pip amplitude will again increase to full scale. Intermediate amplitude calibration points on the crt screen for both the LIN and LOG positions of AMPLITUDE SCALE may be checked against known input levels.

Switch AMPLITUDE SCALE to PWR. Using INPUT ATTENUATOR, STEP and CONTINUOUS, obtain a full-scale pip. Decrease the input amplitude of the signal in 0.1 steps of power. The pip amplitude should decrease approximately one linear division of the crt screen for each 0.1 of reduction of input power. (The voltage required for 0.1-scale deflection is approximately one-third that required for full-scale deflection.)

m. Operation with Model SW-1.

If the Model SPA-3 or SPA-3/25 is supplied with a Model SW-1, interconnect the two units in accordance with paragraph VI-2e. Turn on the power switch of the SW-1. The SW-1 relay should switch at the end of each analyzer sweep.

n. Probe Operation.

If the Model SPA-3 or SPA-3/25 is supplied with a Model PRB-1 probe, perform the following checks.

Set the front-panel control as in paragraph "c" above.

Set the CENTER FREQUENCY dial to 2 MC and the signal generator frequency to 2 mc.

Connect the probe, without any attenuator head, to the analyzer in accordance with paragraph VI-1c. Connect the signal generator to the input of the probe through the normal output termination of the generator. Set the generator level for a full-scale deflection on the crt and note the generator level. Using the 20-db attenuator head, adjust the generator output for full-scale deflection on the crt. If the probe is working correctly, the generator output should be approximately 10 times that required for direct input to the analyzer. Using the 40-db attenuator head, adjust the generator for full-scale deflection. The level should be approximately 100 times that required for direct input. Using the 60-db attenuator head, adjust the generator for full-scale deflection. The level should be approximately 1000 times that required for direct input. Set the generator output for full-scale deflection on the crt. Maintaining a constant amplitude input to the probe, vary the generator frequency from 0.5 mc to 15 mc (to 25 mc with the SPA-3/25), using the CENTER FREQUENCY dial

to keep the pip at the center of the screen. The amplitude variation of the pip should not be greater than  $\pm 2.5$  db.

o. Spare Fuses and Tools.

Check that two 3-a, 250-v cartridge fuses are mounted on the rear apron of the Model PS-19 chassis. Check that the following tools are mounted on the rear apron of the analyzer-section chassis.

- 1--#4 Key for multiple-spline socket screw.
- 1--#6 Key for 4-point-spline socket screw.
- 1--#8 Key for multiple-spline socket screw.
- 1--Walsco #2543 alignment tool.
- 1--Cambridge Thermionic #X2033 alignment tool.

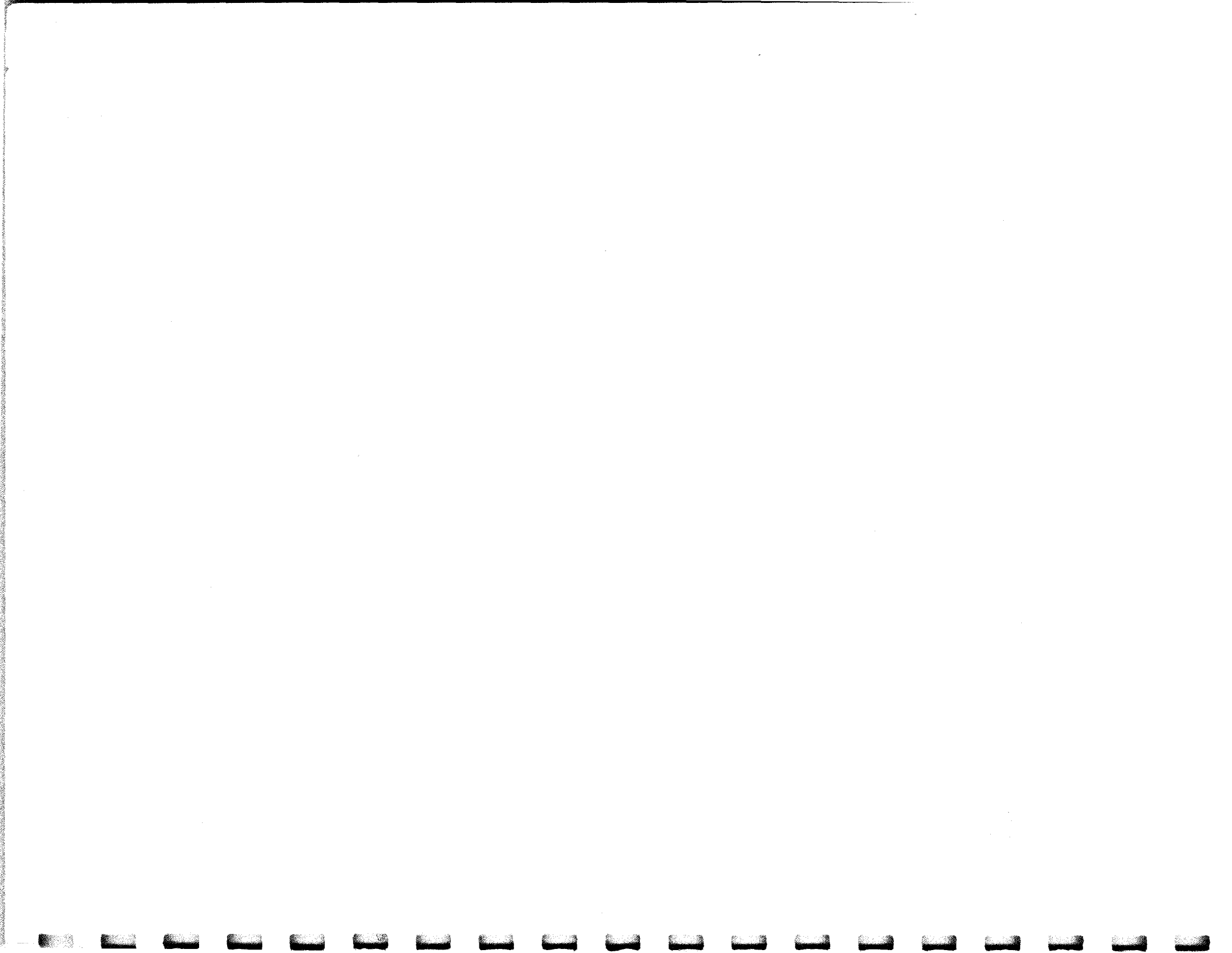



## CHAPTER VI ACCESSORY EQUIPMENT

### INTRODUCTION

This chapter contains information regarding accessory equipment which can be used with the Panoramic Spectrum Analyzer, Model SPA-3 and SPA-3/25.

No attempt to operate the accessory equipment should be made until the user is thoroughly familiar with the entire operating procedure.

#### VI-1. CATHODE FOLLOWER PROBE, MODEL PRB-1.

##### a. GENERAL DESCRIPTION

The Cathode Follower Probe, Model PRB-1, permits connection of signals from a high-impedance source to the Panoramic Spectrum Analyzer, Model SPA-3 or SPA-3/25.

The complete probe consists of a cathode-follower section (with attached rf and power cables), a UHF-to-BNC adapter (usually shipped attached to the rf cable), three attenuator heads (a 20-db head, a 40-db head, and a 60-db head), and three test points (a straight point, a hooked point, and an alligator-clip point).

##### b. SPECIFICATIONS.

|  |                                |
|--|--------------------------------|
| Frequency response, 200 cps to 15 mc (probe by itself) --- | ±1.5 db                        |
| Insertion loss -----                                       | 10 db (approximate)            |
| Input impedance (less attenuator heads)* -----             | 12 megohms<br>shunted by 5 uuf |
| Maximum permissible total rms input voltage                |                                |
| Probe less attenuator head -----                           | .1 volt                        |
| 20-db attenuator head (single gold band) -----             | 1 volt                         |
| 40-db attenuator head (double gold band) -----             | 10 volts                       |
| 60-db attenuator head (triple gold band) -----             | 100 volts                      |

\* The input impedance will depend on the attenuator head being used. Note also that the input impedance will decrease appreciably at the higher frequencies because the transit time in the cathode-follower tube becomes a significant factor.

### c. INSTALLATION.

Connect the 5-contact plug to the PROBE receptacle on the SPA-3 or SPA-3/25 front panel. If not already attached, attach the UHF-to-BNC adapter to the INPUT receptacle on the SPA-3 or SPA-3/25 front panel.

As determined by the signal levels involved (see SPECIFICATIONS), the probe is used without attenuator head or with one of the three supplied attenuator heads. The attenuator heads screw on to the cathode-follower section. Note that to indicate attenuation, the attenuator heads are banded. The single-gold-banded head has an attenuation of 20 db. The double-gold-banded head has an attenuation of 40 db. The triple-gold-banded head has an attenuation of 60 db. For convenience, three different test points are supplied. They screw on to the cathode-follower section (when used without attenuator head) or the attenuator head.

The probe test tip is connected to the signal source. Be sure to connect the ground clip of the probe to the ground side of the signal source.

**CAUTION:** Be sure that the maximum input-signal levels to the probe are not exceeded or harmonics of the input signal will be generated.

The normal overload conditions for the Models SPA-3 and SPA-3/25 apply when the probe is connected. See III-4a(2).

### d. CIRCUIT DESCRIPTION.

The cathode follower is a type 5718 triode whose cathode load is the 72-ohm resistance of the spectrum analyzer input circuit. Plate and heater voltages for the tube are provided through the five-contact plug which is connected to the spectrum analyzer.

The attenuator heads are simple capacitive divider attenuators.

e SERVICE AND MAINTENANCE.

(1) Troubleshooting.

| SYMPTOM                                | CORRECTIVE MEASURES   |
|--|---|
| No output                              | If probe does not get warm:<br><br><ol style="list-style-type: none"><li>1. Check voltages at J103.</li><li>2. Check filament of probe tube for continuity.</li><li>3. Check probe plug for broken leads.</li></ol> |
| No output using Attenuator Head        | Remove head, apply signal directly into probe to determine whether or not the head is defective.  |
| Incorrect output using Attenuator Head | Realign head per paragraph (2) below.   |

(2) Alignment Procedure.

(a) 20-DB Attenuator Head.

- i. Adjust the spectrum analyzer controls for maximum sensitivity and the CENTER FREQUENCY dial to 2 MC. Connect the probe, without any attenuator head, to the input of the analyzer.
- ii. Connect a signal generator (with accurate means of changing and measuring relative level) to the input of the probe. Set the generator frequency to 2 mc. Be sure the generator is connected to the probe through the normal generator output termination. Adjust the generator level for a full-scale pip on the analyzer and note the generator level.
- iii. With the 20-db attenuator head installed, increase the generator output 10 times. If required, adjust the probe for a full-scale pip on the analyzer crt. This is done by an adjusting screw in the tip of the attenuator head. A jeweler's screwdriver is required and is supplied with the probe.

(b) 40-DB Attenuator Head.

- i. Replace the 20-db attenuator head with the 40-db attenuator head.
- ii. Increase the generator output to 100 times the output required for full-scale deflection without attenuator head. If required, adjust the probe for a full scale pip on the analyzer crt.

(c) 60-DB Attenuator Head.

- i. Replace the 40-db attenuator head with the 60-db attenuator head.
- ii. Increase the generator output to 1000 times the output required for full-scale deflection without attenuator head. If required, adjust the probe output for a full-scale pip on the analyzer crt.

(3) Voltage and Resistance Chart.

Meter Readings on R. C. A. Volt Ohmist WV-77A  
Probe PRB-1  
J103

|                |        |
|----------------|--------|
| Voltage pin #A | 4.6VAC |
| #B             | 0.0V   |
| #C             | 0.0V   |
| #D             | 90VDC  |

|                   |                  |
|-------------------|------------------|
| Resistance Pin #A | Less than .1 ohm |
| #B                | Less than .1 ohm |
| #C                | 0 ohm            |
| #D                | 40,000 ohms      |

Figure IV-1. Schematic Diagram, Cathode-Follower Probe, Model PRB-1.

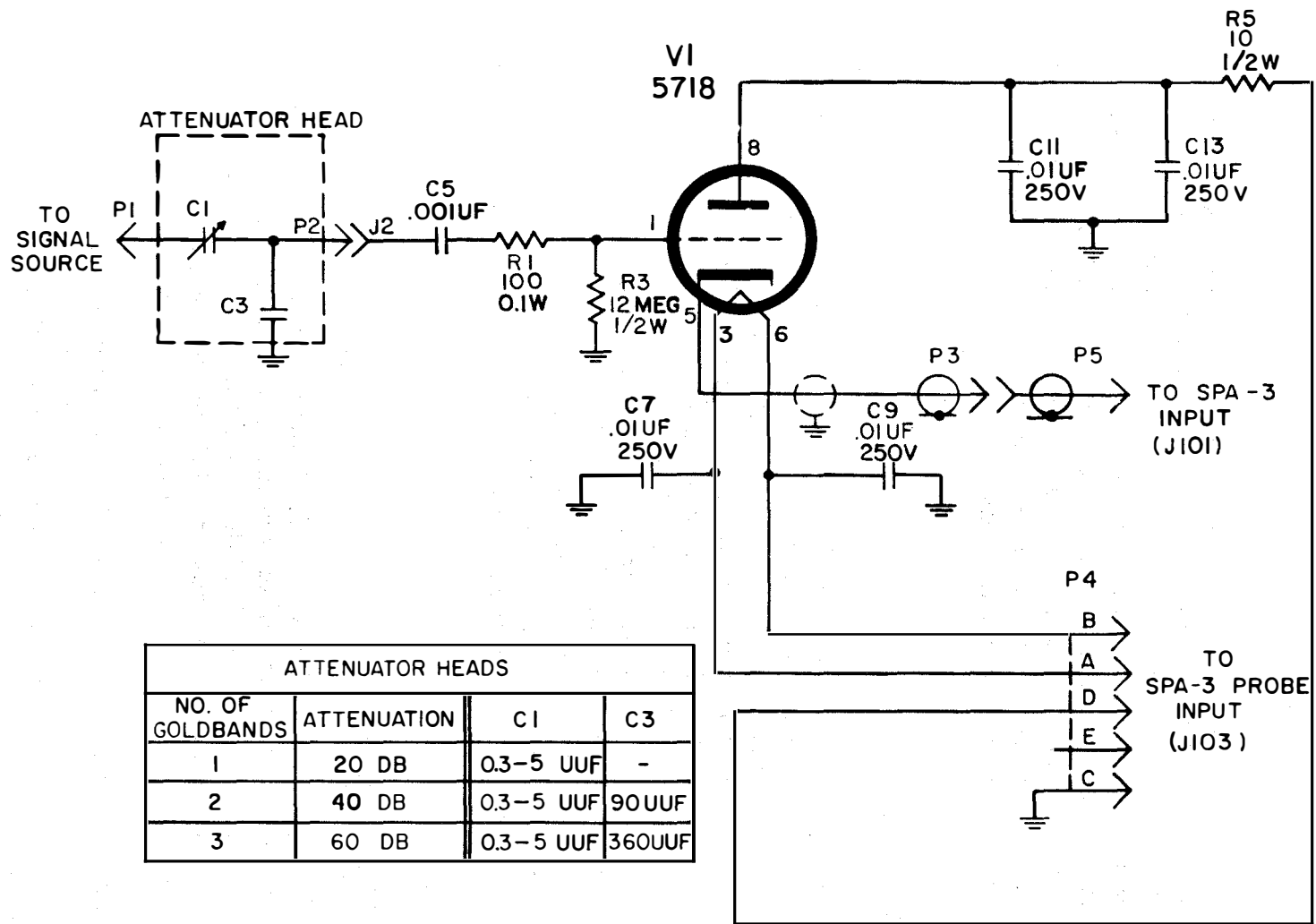

P5-15179

## VI-2. SIGNAL ALTERNATOR, MODEL SW-1.

### a. GENERAL DESCRIPTION.

The Model SW-1 is an auxiliary unit used to cause two signals to alternate on the screen of the spectrum analyzer. The operation of the SW-1 is such that the two signals are presented to the input of the spectrum analyzer alternately in synchronism with the analyzer sweep. This manner of presentation avoids the deleterious beating effects that would occur if both signals were to be applied simultaneously. A very small difference in the frequency of the alternately applied signals can be observed since crt screen persistence causes the two signals to be seen simultaneously.

### b. APPLICATIONS.

As a comparison device the Model SW-1 and the spectrum analyzer make a valuable combination for the study of the frequency characteristic of amplifiers, filters and other devices. For example, the presentation of the characteristics of a known filter can be made to alternate with the presentation of an unknown filter. A difference in response will then be instantly visible in terms of amplitude and frequency. When used with devices that require a synchronous source of swept signal to determine their amplitude-versus-frequency response characteristic (such as filters, transformers and transmission lines and amplifiers), a Panoramic Response Indicator is necessary. When used for the comparison of such devices as oscillators or other sources of energy in the spectrum of interest, the Panoramic Response Indicator is not used.

### c. SPECIFICATIONS.

The Model SW-1 is supplied in a 7-9/16 inch wide x 4-7/8 inch high x 5-1/8 inch deep cabinet. Projection of terminals and other parts results in a 7-9/16 inch wide x 5-3/16 inch high x 6-1/4 inch deep over-all size excluding line cord. The panel and cabinet are finished to match the spectrum analyzer (Munsell N-4.5 gray enamel unless otherwise ordered).

Electrically the unit is compatible with the spectrum analyzer. Rejection of the unwanted input signal is at least 60 db in the frequency range of the spectrum analyzer. The maximum signal amplitude that can be applied to the input terminals of the SW-1 is 500 volts rms. The unit will operate satisfactorily from a 105- to 125-volt, 50- to 60-cps power-line input. A power line cord forms an integral part of the unit.

d. TUBE COMPLEMENT.

| <u>REFERENCE SYMBOL</u> | <u>TUBE TYPE</u> | <u>FUNCTION</u>        |
|-------------------------|------------------|------------------------|
| V1                      | 5963             | Synch Pulse Amplifier  |
| V2                      | 12BH7            | Bistable Multivibrator |

e. INSTALLATION AND OPERATING INSTRUCTIONS.

(1) Connect the Model SW-1 OUTPUT terminals to the spectrum analyzer INPUT connector.

(2) Connect one of the signal sources to INPUT 1 of the Model SW-1.

(3) Connect the other signal source to INPUT 2 of the Model SW-1.

Caution: To minimize interaction between the two signal sources the input leads from the two signal sources must either be well separated or shielded.

(4) Connect the spectrum analyzer SYNC PULSE OUT terminals (rear of analyzer chassis) to the Model SW-1 SYNC terminals.

(5) Connect the Model SW-1 line cord to a source of 105- to 125-volt, 50- to 60-cps power.

(6) The unit is now ready for use. The normal operating instructions pertain to the spectrum analyzer. The Model SW-1 merely serves as a synchronous means of alternating the input to the spectrum analyzer. Note, however, that at faster sweep rates the switching time is an appreciable part of the sweep interval. Thus, there will be a partial loss of sweep width.

NOTE: If the Model SW-1 is being used at the same time that some other device is connected to the spectrum analyzer SYNC PULSE OUT terminals, then for satisfactory Model SW-1 operation the other device must have an input impedance of at least 100 k with a suitable decoupling capacitor.

f. THEORY OF OPERATION.

A synchronizing pulse derived from the spectrum analyzer sawtooth is connected from the spectrum analyzer SYNC PULSE OUT terminals to the SYNC input of the Signal Alternator. This sync pulse is amplified by V1 and then

coupled to a bistable multivibrator V2. The multivibrator has two stable conditions. In one, the first half of V2 is cut-off and the second half of V2 is conducting. In the second, the first half of V2 is conducting and the second half of V2 is cut-off. Each time a sync pulse is injected into the multivibrator the cut-off section is caused to conduct, thereby cutting off the section that was conducting. A relay in the plate circuit of one of the triodes of V2 will therefore go on and off in synchronism with the spectrum analyzer sweep. The relay has a 4PDT contact arrangement. The output contact is connected to the analyzer input. Two signals are connected, one each, to the input contacts. As the relay goes on and off, the signals are alternately connected to the spectrum analyzer input. Therefore, one sweep will show a pattern for signal number 1 and the next sweep for signal number 2.

g. SERVICE AND MAINTENANCE.

NOTE: To remove the equipment from its cabinet it is necessary to remove the four panel mounting screws and the two felt mounting feet at the rear of the unit.

(1) Trouble-Shooting Chart.

| SYMPTOM   | CORRECTIVE MEASURE   |
|---|--|
| The crt presentation does not alternate.        | <p>If the relay arm functions:<br/>Check relay contacts.</p> <p>If the relay arm does not function:<br/>Check V2, V1.<br/>Check for open relay coil.<br/>Check relay contacts.</p> |
| Switching skips occasionally.                   | <p>Check V1, V2.<br/>Check sync pulse from analyzer.<br/>Check contacts.</p>   |
| Relay switches out-of-step with analyzer sweep. | <p>Check V2, Vi particularly for microphonics.</p> <p>Check for power line variations.</p>   |



(2) Voltage and Resistance Chart, Model SW-1

All readings taken with RCA Voltohmyst, Model WV-77B.

| VI - 5963 |         |      | V2 - 12BH7 |         |      |
|-----------|---------|------|------------|---------|------|
| PIN       | V       | R    | PIN        | V       | R    |
| 1         | 135     | DNM  | 1          | 120     | DNM  |
| 2         | 0       | 0    | 2          | 32      | 260K |
| 3         | 10      | 240K | 3          | 55      | 3.3K |
| 4         | 6.3 VAC | *    | 4          | 6.3 VAC | *    |
| 5         | 6.3 VAC | *    | 5          | 6.3 VAC | *    |
| 6         | 320     | DNM  | 6          | 125     | DNM  |
| 7         | 135     | DNM  | 7          | 32      | 260K |
| 8         | 162     | 100K | 8          | 55      | 3.3K |
| 9         | 0       | 0    | 9          | 0       | 0    |

Notes: All voltages dc unless otherwise specified.  
All measurements between pin specified and chassis ground.  
DNM indicates leakage measurement; do not measure.  
\* indicates very low resistance.

Figure VI-2. Schematic Diagram, Signal Alternator, Model SW-1.

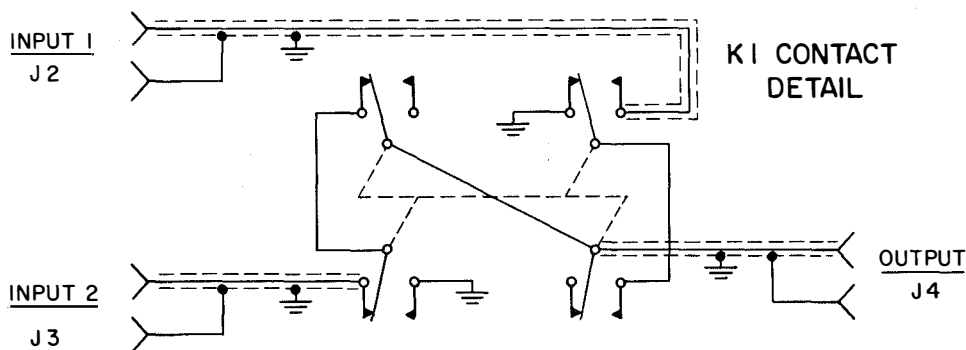
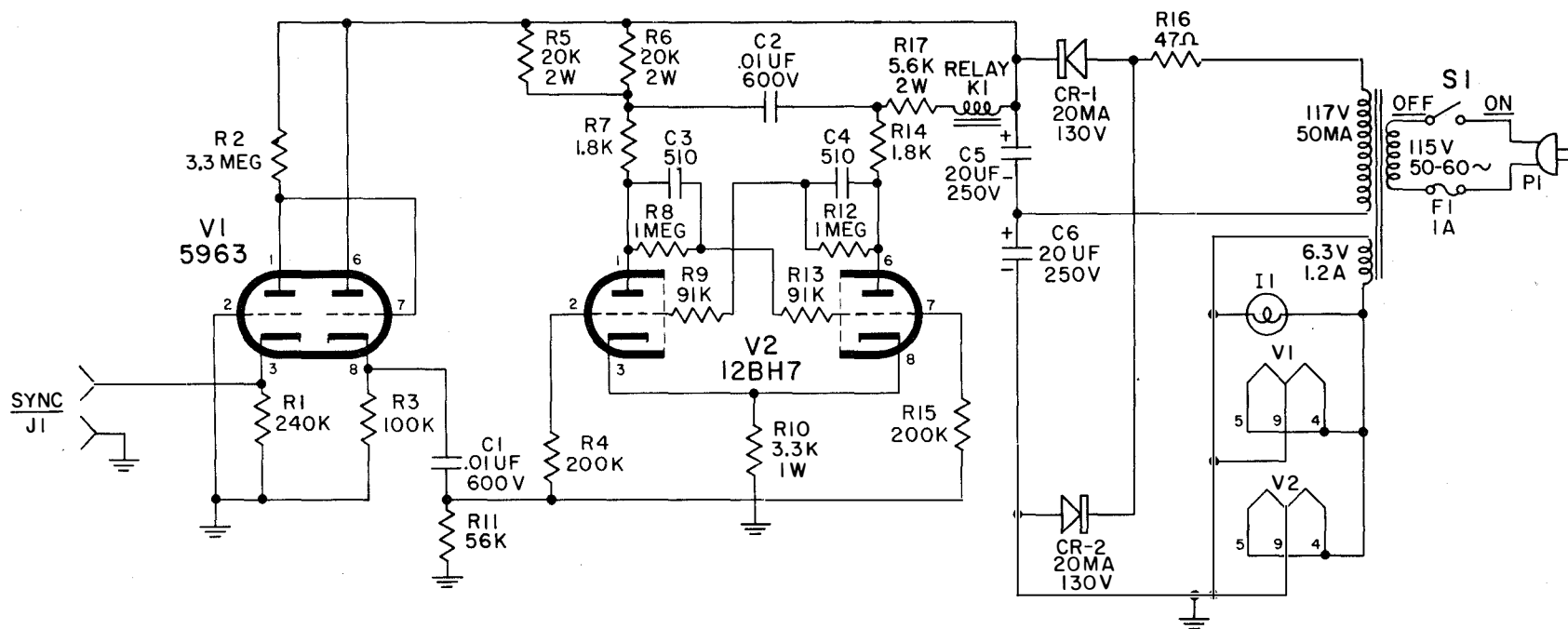

NOTES:

1. ALL RESISTORS ARE 1/2 WATT UNLESS OTHERWISE SPECIFIED.
2. ALL CAPACITOR VALUES ARE IN UUF UNLESS OTHERWISE SPECIFIED.
3. UNDERLINED TITLES APPEAR ON FRONT PANEL.

## CHAPTER VII LIST OF REPLACEABLE PARTS

### VII-1. INTRODUCTION.

- a. This list is divided into four sections. The first section covers the Analyzer, Model SPA-3. The second section covers the Power Supply, Model PS-19. The third section covers the Probe, Model PRB-1. The fourth section covers the Signal Alternator, Model SW-1.
  
- b. In the case where an item appears more than once, the total quantity is listed only once per section in the "number in set" column. It is listed the first time the item appears in each section.
  
- c. A list of Manufacturers' Code Letters used in this list is given on the last page of this chapter.
  
- d. In some cases, the values, ratings and source (manufacturer) shown are nominal and variations may be found. Satisfactory replacement may be made with either the listed component or an exact replacement for the part removed from the equipment.

When ordering parts from the factory, always include the following equipment:

1. Instrument Model Number.
2. Circuit Reference Symbol.
3. Description of Part.
4. Panoramic Part Number.

### VII-2. LIST OF REPLACEABLE PARTS.

List of Replaceable Parts for Model SPA-3

| Circuit Ref Symbol | Stock No. | Description   | Mfr & Mfrs No.      | Qty In Set | Qty 3 Mo. Opn | Unit Price |
|--------------------|-----------|---|---------------------|------------|---------------|------------|
| C101               |           | Capacitor: fixed, ceramic disc<br>.05 uf, 500 V<br>Pan Part CC-2123-1             | AW<br>41C105        | 13         |               |            |
| C102               |           | Capacitor: fixed, silvered mica<br>220 uuf, $\pm 5\%$<br>Pan Part CM20C221J       | AL<br>CM20C<br>221J | 1          |               |            |
| C103               |           | Capacitor: fixed, ceramic disc<br>.05 uf, 500 V<br>Pan Part CC-2123-1             | AW<br>41C105        |            |               |            |
| C107               |           | Capacitor: variable, piston type<br>1-18 uuf<br>Pan Part CV2099                   | AR<br>VC-4G         | 3          |               |            |
| C109               |           | Capacitor: fixed, ceramic disc<br>.05 uf, 500 V<br>Pan Part CC-2123-1             | AW<br>41C105        |            |               |            |
| C111               |           | Capacitor: fixed, ceramic disc<br>.05 uf, 500 V<br>Pan Part CC-2123-1             | AW<br>41C105        |            |               |            |
| C113               |           | Capacitor: fixed, ceramic<br>3.3 uuf, $\pm 20\%$ , 500 VDC<br>Pan Part CC-2037-15 | AN<br>Type GA       | 1          |               |            |
| C115               |           | Capacitor: variable, piston type<br>1-18 uuf<br>Pan Part CV2099                   | AR<br>VC-4G         |            |               |            |
| C117               |           | Capacitor: variable, piston type<br>1-18 uuf<br>Pan Part CV2099                   | AR<br>VC-4G         |            |               |            |
| C119               |           | Capacitor: fixed, ceramic disc<br>.05 uf, 500 V<br>Pan Part CC-2123-1             | AW<br>41C105        |            |               |            |

List of Replaceable Parts for Model SPA-3 (continued)

| Circuit Ref Symbol    | Stock No. | Description  | Mfr & Mfrs No.     | Qty In Set | Qty 3 Mo. Opn | Unit Price |
|-----------------------|-----------|--|--------------------|------------|---------------|------------|
| C121                  |           | Capacitor: fixed, ceramic disc<br>.05 uf, 500 V<br>Pan Part CC-2123-1                          | AW<br>41C105       |            |               |            |
| C123                  |           | Capacitor: fixed, ceramic disc<br>.01 uf, $\pm 20\%$ , 500 V<br>Pan Part CC 2003-17            | AA<br>36-103W      | 34         |               |            |
| C125                  |           | Capacitor: fixed, ceramic disc<br>.01 uf, $\pm 20\%$ , 500 V<br>Pan Part CC 2003-17            | AA<br>36-103W      |            |               |            |
| C127                  |           | Capacitor: fixed, ceramic disc<br>.01 uf, $\pm 20\%$ , 500 V<br>Pan Part CC 2003-17            | AA<br>36-103W      |            |               |            |
| C129                  |           | Capacitor: fixed, ceramic disc<br>.01 uf, $\pm 20\%$ , 500 V<br>Pan Part CC 2003-17            | AA<br>36-103W      |            |               |            |
| C131                  |           | Capacitor: variable, piston type<br>1-5 uuf<br>Pan Part CV2051                                 | AR<br>VC-5         | 1          |               |            |
| C133                  |           | Capacitor: fixed, ceramic disc<br>.05 uf, 500 V<br>Pan Part CC-2123-1                          | AW<br>41C105       |            |               |            |
| C135                  |           | Capacitor: fixed, ceramic disc<br>.01 uf, $\pm 20\%$ , 500 V<br>Pan Part CC 2003-17            | AA<br>36-103W      |            |               |            |
| C136                  |           | Capacitor: fixed, ceramic<br>feed thru<br>1500 uuf, $\pm 20\%$ , 500 VDC<br>Pan Part CC2161-13 | AM<br>357-152      | 6          |               |            |
| C137<br>A, B,<br>C, D |           | Capacitor: fixed, electrolytic<br>twistlock<br>4 x 40 uf, 450 V<br>Pan Part CE34X400R-1        | AW<br>TVL 47<br>75 |            |               |            |

List of Replaceable Parts for Model SPA-3 (continued)

| Circuit Ref Symbol | Stock No. | Description  | Mfr & Mfrs No.      | Qty In Set | Qty 3 Mo. Opn | Unit Price |
|--------------------|-----------|--|---------------------|------------|---------------|------------|
| C139               |           | Capacitor: fixed, ceramic disc<br>.01 uf, $\pm 20\%$ , 500 V<br>Pan Part CC 2003-17  | AA<br>36-103W       |            |               |            |
| C141               |           | Capacitor: fixed, ceramic disc<br>.01 uf, $\pm 20\%$ , 500 V<br>Pan Part CC 2003-17  | AA<br>36-103W       |            |               |            |
| C143               |           | Capacitor: fixed, ceramic disc<br>.05 uf, 500 V<br>Pan Part CC-2123-1                | AW<br>41C105        |            |               |            |
| C145               |           | Capacitor: fixed, ceramic disc<br>.01 uf, $\pm 20\%$ , 500 V<br>Pan Part CC 2003-17  | AA<br>36-103W       |            |               |            |
| C147               |           | Capacitor: fixed, composition<br>2.2 uuf, 500 VDC, $\pm 10\%$<br>Pan Part CC-1270-15 | AN<br>Type GA       | 1          |               |            |
| C149               |           | Capacitor: fixed, ceramic disc<br>.01 uf, $\pm 20\%$ , 500 V<br>Pan Part CC 2003-17  | AA<br>36-103W       |            |               |            |
| C151               |           | Capacitor: fixed, ceramic disc<br>.01 uf, $\pm 20\%$ , 500 V<br>Pan Part CC 2003-17  | AA<br>36-103W       |            |               |            |
| C153               |           | Capacitor: fixed, silvered mica<br>51 uuf, $\pm 5\%$<br>Pan Part CM15C510J           | AL<br>CM15C<br>510J | 1          |               |            |
| C155               |           | Capacitor: fixed, ceramic disc<br>.01 uf, $\pm 20\%$ , 500 V<br>Pan Part CC 2003-17  | AA<br>36-103W       |            |               |            |
| C157               |           | Capacitor: fixed, ceramic disc<br>.01 uf, $\pm 20\%$ , 500 V<br>Pan Part CC 2003-17  | AA<br>36-103W       |            |               |            |

## List of Replaceable Parts for Model SPA-3 (continued)

| Circuit Ref Symbol | Stock No. | Description  | Mfr & Mfrs No.               | Qty In Set | Qty 3 Mo. Opn | Unit Price |
|--------------------|-----------|--|------------------------------|------------|---------------|------------|
| C159               |           | Capacitor: fixed, ceramic disc<br>.01 uf, $\pm 20\%$ , 500 V<br>Pan Part CC 2003-17            | AA<br>36-103W                |            |               |            |
| C161               |           | Capacitor: fixed, ceramic disc<br>.01 uf, $\pm 20\%$ , 500 V<br>Pan Part CC 2003-17            | AA<br>36-103W                |            |               |            |
| C162               |           | Capacitor: fixed, ceramic<br>feed thru<br>1500 uuf, $\pm 20\%$ , 500 VDC<br>Pan Part CC2161-13 | AM<br>357-152                |            |               |            |
| C163               |           | Capacitor: fixed, ceramic disc<br>.01 uf, $\pm 20\%$ , 500 V<br>Pan Part CC 2003-17            | AA<br>36-103W                |            |               |            |
| C164               |           | Capacitor: fixed, ceramic disc<br>.01 uf, $\pm 20\%$ , 500 V<br>Pan Part CC 2003-17            | AA<br>36-103W                |            |               |            |
| C165               |           | Capacitor: fixed, ceramic disc<br>.01 uf, $\pm 20\%$ , 500 V<br>Pan Part CC 2003-17            | AA<br>36-103W                |            |               |            |
| C167               |           | Capacitor: variable, ceramic<br>trimmer<br>8-50 uuf<br>Pan Part CV 2022                        | AF<br>Type<br>N-650<br>822AN | 3          |               |            |
| C169               |           | Capacitor: fixed, silvered mica<br>15 uuf, $\pm 5\%$<br>Pan Part CM15C150J                     | AL<br>CM15C<br>150J          | 1          |               |            |
| C171               |           | Capacitor: fixed, ceramic disc<br>.01 uf, $\pm 20\%$ , 500 V<br>Pan Part CC 2003-17            | AA<br>36-103W                |            |               |            |

## List of Replaceable Parts for Model SPA-3 (continued)

| Circuit Ref Symbol | Stock No. | Description   | Mfr & Mfrs No.               | Qty In Set | Qty 3 Mo. Opn | Unit Price |
|--------------------|-----------|---|------------------------------|------------|---------------|------------|
| C173               |           | Capacitor: fixed, ceramic disc<br>.02 uf, $\pm 20\%$ , 500 V<br>Pan Part CC2055-1   | AW<br>29C187A                | 21         |               |            |
| C175               |           | Capacitor: fixed, ceramic disc<br>.01 uf, $\pm 20\%$ , 500 V<br>Pan Part CC 2003-17 | AA<br>36-103W                |            |               |            |
| C177               |           | Capacitor: fixed, ceramic disc<br>.01 uf, $\pm 20\%$ , 500 V<br>Pan Part CC 2003-17 | AA<br>36-103W                |            |               |            |
| C179               |           | Capacitor: variable, ceramic<br>trimmer<br>8-50 uuf<br>Pan Part CV 2022             | AF<br>Type<br>N-650<br>822AN |            |               |            |
| C181               |           | Capacitor: fixed, ceramic disc<br>.01 uf, $\pm 20\%$ , 500 V<br>Pan Part CC 2003-17 | AA<br>36-103W                |            |               |            |
| C183               |           | Capacitor: fixed, ceramic disc<br>.01 uf, $\pm 20\%$ , 500 V<br>Pan Part CC 2003-17 | AA<br>36-103W                |            |               |            |
| C185               |           | Capacitor: variable, ceramic<br>trimmer<br>8-50 uuf<br>Pan Part CV 2022             | AF<br>Type<br>N-650          |            |               |            |
| C187               |           | Capacitor: fixed, ceramic disc<br>.01 uf, $\pm 20\%$ , 500 V<br>Pan Part CC 2003-17 | AA<br>36-103W                |            |               |            |
| C189               |           | Capacitor: fixed, silvered mica<br>20 uuf, $\pm 5\%$<br>Pan Part CM15C200J          | AL<br>CM15C<br>200J          | 3          |               |            |



List of Replaceable Parts for Model SPA-3 (continued)

| Circuit Ref Symbol | Stock No. | Description   | Mfr & Mfrs No.      | Qty In Set | Qty 3 Mo. Opn | Unit Price |
|--------------------|-----------|---|---------------------|------------|---------------|------------|
| C191               |           | Capacitor: fixed, ceramic disc<br>.01 uf, $\pm 20\%$ , 500 V<br>Pan Part CC 2003-17 | AA<br>36-103W       |            |               |            |
| C193               |           | Capacitor: fixed, ceramic disc<br>.02 uf, $\pm 20\%$ , 500 V<br>Pan Part CC 2055-1  | AW<br>29C187A       |            |               |            |
| C195               |           | Capacitor: fixed, ceramic disc<br>.01 uf, $\pm 20\%$ , 500 V<br>Pan Part CC 2003-17 | AA<br>36-103W       |            |               |            |
| C197               |           | Capacitor: fixed, silvered mica<br>100 uuf, $\pm 5\%$<br>Pan Part CM20C101J         | AL<br>CM20C<br>101J | 5          |               |            |
| C199               |           | Capacitor: fixed, silvered mica<br>270 uuf, $\pm 5\%$<br>Pan Part CM15C271J         | AL<br>CM15C<br>271J | 1          |               |            |
| C203               |           | Capacitor: fixed, ceramic disc<br>.01 uf, $\pm 20\%$ , 500 V<br>Pan Part CC 2003-17 | AA<br>36-103W       |            |               |            |
| C207               |           | Capacitor: fixed, ceramic disc<br>.01 uf, $\pm 20\%$ , 500 V<br>Pan Part CC 2003-17 | AA<br>36-103W       |            |               |            |
| C209               |           | Capacitor: fixed, silvered mica<br>100 uuf, $\pm 5\%$<br>Pan Part CM20C101J         | AL<br>CM20C<br>101J |            |               |            |
| C211               |           | Capacitor: fixed, ceramic disc<br>.05 uf, 500 V<br>Pan Part CC-2123-1               | AW<br>41C105        |            |               |            |
| C213               |           | Capacitor: fixed, mylar<br>1000 uuf, 400 V<br>Pan Part CT 2094-5                    | AP<br>338E10<br>2M  | 1          |               |            |

List of Replaceable Parts for Model SPA-3 (continued)

| Circuit Ref Symbol | Stock No. | Description   | Mfr & Mfrs No.      | Qty In Set | Qty 3 Mo. Opn | Unit Price |
|--------------------|-----------|---|---------------------|------------|---------------|------------|
| C215               |           | Capacitor: fixed, silvered mica<br>100 uuf, $\pm 5\%$<br>Pan Part CM20C101J         | AL<br>CM20C<br>101J |            |               |            |
| C217               |           | Capacitor: fixed, ceramic disc<br>.01 uf, $\pm 20\%$ , 500 V<br>Pan Part CC 2003-17 | AA<br>36-103W       |            |               |            |
| C219               |           | Capacitor: fixed, ceramic disc<br>.05 uf, 500 V<br>Pan Part CC-2123-1               | AW<br>41C105        |            |               |            |
| C220               |           | Capacitor: fixed, ceramic disc<br>.05 uf, 500 V<br>Pan Part CC-2123-1               | AW<br>41C105        |            |               |            |
| C221               |           | Capacitor: fixed, silvered mica<br>240 uuf, $\pm 5\%$<br>Pan Part CM20C241J         | AL<br>CM20C<br>241J | 1          |               |            |
| C223               |           | Capacitor: fixed, silvered mica<br>75 uuf, $\pm 5\%$<br>Pan Part CM15C750J          | AL<br>CM15C<br>750J | 1          |               |            |
| C225               |           | Capacitor: fixed, silvered mica<br>750 uuf, $\pm 5\%$<br>Pan Part CM20C751J         | AL<br>CM20C<br>751J | 1          |               |            |
| C227               |           | Capacitor: fixed, mylar<br>.22 uf, 400 V<br>Pan Part CT 2151-5                      | AP<br>338E22<br>4M  | 1          |               |            |
| C229               |           | Capacitor: fixed, molded tubular<br>.1 uf, 200 V<br>Pan Part CT-2038-1              | AW<br>2TM-P1        | 1          |               |            |
| C231               |           | Capacitor: fixed, ceramic disc<br>.01 uf, $\pm 20\%$ , 500 V<br>Pan Part CC 2003-17 | AA<br>36-103W       |            |               |            |

List of Replaceable Parts for Model SPA-3 (continued)

| Circuit Ref Symbol | Stock No. | Description   | Mfr & Mfrs No.      | Qty In Set | Qty 3 Mo. Opn | Unit Price |
|--------------------|-----------|---|---------------------|------------|---------------|------------|
| C233               |           | Capacitor: fixed, silvered mica<br>10 uuf, $\pm 5\%$<br>Pan Part CM20C100J          | AL<br>CM20C<br>100J | 1          |               |            |
| C235               |           | Capacitor: fixed, ceramic disc<br>.01 uf, $\pm 20\%$ , 500 V<br>Pan Part CC 2003-17 | AA<br>36-103W       |            |               |            |
| C237               |           | Capacitor: fixed, silvered mica<br>470 uuf, $\pm 5\%$<br>Pan Part CM20C471J         | AL<br>CM20C<br>471J | 1          |               |            |
| C239               |           | Capacitor: fixed, silvered mica<br>100 uuf, $\pm 5\%$<br>Pan Part CM20C101J         | AL<br>CM20C<br>101J |            |               |            |
| C241               |           | Capacitor: fixed, silvered mica<br>100 uuf, $\pm 5\%$<br>Pan Part CM20C101J         | AL<br>CM20C<br>101J |            |               |            |
| C245               |           | Capacitor: fixed, ceramic disc<br>.01 uf, $\pm 20\%$ , 500 V<br>Pan Part CC 2003-17 | AA<br>36-103W       |            |               |            |
| C247               |           | Capacitor: fixed, ceramic disc<br>.02 uf, $\pm 20\%$ , 500 V<br>Pan Part CC2055-1   | AW<br>29C18<br>7A   |            |               |            |
| C249               |           | Capacitor: fixed, ceramic disc<br>.02 uf, $\pm 20\%$ , 500 V<br>Pan Part CC2055-1   | AW<br>29C18<br>7A   |            |               |            |
| C251               |           | Capacitor: fixed, ceramic disc<br>.02 uf, $\pm 20\%$ , 500 V<br>Pan Part CC2055-1   | AW<br>29C18<br>7A   |            |               |            |
| C253               |           | Capacitor: fixed, ceramic disc<br>.02 uf, $\pm 20\%$ , 500 V<br>Pan Part CC2055-1   | AW<br>29C18<br>7A   |            |               |            |

List of Replaceable Parts for Model SPA-3 (continued)

| Circuit Ref Symbol | Stock No. | Description  | Mfr & Mfrs No.      | Qty In Set | Qty 3 Mo. Opn | Unit Price |
|--------------------|-----------|--|---------------------|------------|---------------|------------|
| C255               |           | Capacitor: fixed, silvered mica<br>430 uuf, $\pm 5\%$<br>Pan Part CM15C431J        | AL<br>CM15C<br>431J | 4          |               |            |
| C257               |           | Capacitor: fixed, silvered mica<br>430 uuf, $\pm 5\%$<br>Pan Part CM15C431J        | AL<br>CM15C<br>431J |            |               |            |
| C259               |           | Capacitor: fixed, silvered mica<br>430 uuf, $\pm 5\%$<br>Pan Part CM15C431J        | AL<br>CM15C<br>431J |            |               |            |
| C261               |           | Capacitor: fixed, silvered mica<br>430 uuf, $\pm 5\%$<br>Pan Part CM15C431J        | AL<br>CM15C<br>431J |            |               |            |
| C263               |           | Capacitor: variable, ceramic<br>NPO Trimmer<br>1.5 to 7 uuf<br>Pan Part CV2140J-14 | AF<br>822-E2        | 1          |               |            |
| C265<br>A, B       |           | Capacitor: dual variable, air<br>dielectric<br>6.5 - 51 uuf<br>Pan Part CV 2002    | AK<br>167-52        | 1          |               |            |
| C267               |           | Capacitor: adjustable, air<br>trimmer<br>2 - 3 uuf<br>Pan Part CV 1247M            | AE<br>PL 6000       | 1          |               |            |
| C269               |           | Capacitor: fixed, silvered mica<br>20 uuf, $\pm 5\%$<br>Pan Part CM15C200J         | AL<br>CM15C<br>200J |            |               |            |
| C271               |           | Capacitor: fixed, silvered mica<br>20 uuf, $\pm 5\%$<br>Pan Part CM15C200J         | AL<br>CM15C<br>200J |            |               |            |

List of Replaceable Parts for Model SPA-3 (continued)

| Circuit Ref Symbol | Stock No. | Description   | Mfr & Mfrs No.      | Qty In Set | Qty 3 Mo. Opn | Unit Price |
|--------------------|-----------|---|---------------------|------------|---------------|------------|
| C273               |           | Capacitor: fixed, silvered mica<br>47 uuf, $\pm 5\%$<br>Pan Part CM15C470J          | AL<br>CM15C<br>470J | 1          |               |            |
| C275               |           | Capacitor: fixed, ceramic disc<br>.02 uf, $\pm 20\%$ , 500 V<br>Pan Part CC2055-1   | AW<br>29C187A       |            |               |            |
| C277               |           | Capacitor: fixed, silvered mica<br>1000 uuf, $\pm 5\%$<br>Pan Part CM20C102J        | AL<br>CM20C<br>102J | 2          |               |            |
| C279               |           | Capacitor: fixed, silvered mica<br>1000 uuf, $\pm 5\%$<br>Pan Part CM20C102J        | AL<br>CM20C<br>102J |            |               |            |
| C281               |           | Capacitor: fixed, ceramic disc<br>.01 uf, $\pm 20\%$ , 500 V<br>Pan Part CC 2003-17 | AA<br>36-103W       |            |               |            |
| C283               |           | Capacitor: fixed, ceramic disc<br>.01 uf, $\pm 20\%$ , 500 V<br>Pan Part CC 2003-17 | AA<br>36-103W       |            |               |            |
| C285               |           | Capacitor: fixed, mylar<br>4700 uuf, 400 V<br>Pan Part CT 2132-5                    | AP<br>338E47<br>2M  | 1          |               |            |
| C287               |           | Capacitor: fixed, ceramic disc<br>.01 uf, $\pm 20\%$ , 500 V<br>Pan Part CC 2003-17 | AA<br>36-103W       |            |               |            |
| C289               |           | Capacitor: fixed, molded tubular<br>.022 uf, 400 V<br>Pan Part CT-2073-1            | AW<br>4TM-522       | 1          |               |            |
| C291               |           | Capacitor: fixed, silvered mica<br>91 uuf, $\pm 5\%$<br>Pan Part CM20C910J          | AL<br>CM20C<br>910J | 1          |               |            |

List of Replaceable Parts for Model SPA-3 (continued)

| Circuit Ref Symbol | Stock No. | Description   | Mfr & Mfrs No.      | Qty In Set | Qty 3 Mo. Opn | Unit Price |
|--------------------|-----------|---|---------------------|------------|---------------|------------|
| C292               |           | Capacitor: fixed, silvered mica<br>1000 uuf, $\pm 5\%$<br>Pan Part CM20C102J      | AL<br>CM20C<br>102J |            |               |            |
| C293               |           | Capacitor: fixed, molded tubular<br>.25 uf, 400 V<br>Pan Part CT 2020-4           | AJ<br>4P25          | 1          |               |            |
| C295               |           | Capacitor: fixed, ceramic disc<br>.02 uf, $\pm 20\%$ , 500 V<br>Pan Part CC2055-1 | AW<br>29C187A       |            |               |            |
| C297               |           | Capacitor: fixed, ceramic disc<br>.02 uf, $\pm 20\%$ , 500 V<br>Pan Part CC2055-1 | AW<br>29C187A       |            |               |            |
| C299               |           | Capacitor: fixed, ceramic disc<br>.02 uf, $\pm 20\%$ , 500 V<br>Pan Part CC2055-1 | AW<br>29C187A       |            |               |            |
| C301               |           | Capacitor: fixed, ceramic disc<br>.02 uf, $\pm 20\%$ , 500 V<br>Pan Part CC2055-1 | AW<br>29C187A       |            |               |            |
| C303               |           | Capacitor: fixed, ceramic disc<br>.02 uf, $\pm 20\%$ , 500 V<br>Pan Part CC2055-1 | AW<br>29C187A       |            |               |            |
| C305               |           | Capacitor: fixed, ceramic disc<br>.02 uf, $\pm 20\%$ , 500 V<br>Pan Part CC2055-1 | AW<br>29C187A       |            |               |            |
| C307               |           | Capacitor: fixed, ceramic disc<br>.02 uf, $\pm 20\%$ , 500 V<br>Pan Part CC2055-1 | AW<br>29C187A       |            |               |            |
| C309               |           | Capacitor: fixed, ceramic disc<br>.02 uf, $\pm 20\%$ , 500 V<br>Pan Part CC2055-1 | AW<br>29C187A       |            |               |            |

List of Replaceable Parts for Model SPA-3 (continued)

| Circuit Ref Symbol | Stock No. | Description  | Mfr & Mfrs No.    | Qty In Set | Qty 3 Mo. Opn | Unit Price |
|--------------------|-----------|--|-------------------|------------|---------------|------------|
| C311               |           | Capacitor: fixed, ceramic disc<br>.02 uf, $\pm 20\%$ , 500 V<br>Pan Part CC2055-1    | AW<br>29C187A     |            |               |            |
| C313               |           | Capacitor: fixed, ceramic disc<br>.02 uf, $\pm 20\%$ , 500 V<br>Pan Part CC2055-1    | AW<br>29C187A     |            |               |            |
| C315               |           | Capacitor: fixed, ceramic disc<br>.02 uf, $\pm 20\%$ , 500 V<br>Pan Part CC2055-1    | AW<br>29C187A     |            |               |            |
| C317               |           | Capacitor: fixed, ceramic disc<br>.02 uf, $\pm 20\%$ , 500 V<br>Pan Part CC 2055-1   | AW<br>29C187A     |            |               |            |
| C319               |           | Capacitor: fixed, ceramic disc<br>.02 uf, $\pm 20\%$ , 500 V<br>Pan Part CC 2055-1   | AW<br>29C187A     |            |               |            |
| C321               |           | Capacitor: fixed, ceramic disc<br>.02 uf, $\pm 20\%$ , 500 V<br>Pan Part CC 2055-1   | AW<br>29C187A     |            |               |            |
| C323               |           | Capacitor: fixed, ceramic disc<br>.02 uf, $\pm 20\%$ , 500 V<br>Pan Part CC 2055-1   | AW<br>29C187A     |            |               |            |
| C325               |           | Capacitor: fixed, ceramic disc<br>.02 uf, $\pm 20\%$ , 500 V<br>Pan Part CC 2055-1   | AW<br>29C187A     |            |               |            |
| C326               |           | Capacitor: fixed, ceramic disc<br>.05 uf, 500 V<br>Pan Part CC-2123-1                | AW<br>41C105      |            |               |            |
| C327               |           | Capacitor: fixed, electrolytic<br>twistlock<br>2000 uf, 15 V<br>Pan Part CE31X202E-1 | AW<br>TVL<br>1168 | 1          |               |            |

List of Replaceable Parts for Model SPA-3 (continued)

| Circuit Ref Symbol | Stock No. | Description  | Mfr & Mfrs No.      | Qty In Set | Qty 3 Mo. Opn | Unit Price |
|--------------------|-----------|--|---------------------|------------|---------------|------------|
| C328               |           | Capacitor: fixed, ceramic disc<br>.05 uf, 500 V<br>Pan Part CC-2123-1                          | AW<br>41C105        |            |               |            |
| C329               |           | Capacitor: fixed, silvered mica<br>200 uuf, $\pm 5\%$<br>Pan Part CM15E201J                    | AT<br>CM15E<br>201J | 1          |               |            |
| C331               |           | Capacitor: fixed, ceramic<br>feed thru<br>1500 uuf, $\pm 20\%$ , 500 VDC<br>Pan Part CC2161-13 | AM<br>357-152       |            |               |            |
| C333               |           | Capacitor: fixed, ceramic<br>feed thru<br>1500 uuf, $\pm 20\%$ , 500 VDC<br>Pan Part CC2161-13 | AM<br>357-152       |            |               |            |
| C335               |           | Capacitor: fixed, ceramic<br>feed thru<br>1500 uuf, $\pm 20\%$ , 500 VDC<br>Pan Part CC2161-13 | AM<br>357-152       |            |               |            |
| C337               |           | Capacitor: fixed, ceramic<br>feed thru<br>1500 uuf, $\pm 20\%$ , 500 VDC<br>Pan Part CC2161-13 | AM<br>357-152       |            |               |            |
| CR101              |           | Rectifier: selenium, bridge<br>1.5 amp, 26 VAC, 4 cell<br>Pan Part CR-2010                     | AV<br>16S1B1<br>S1G | 1          |               |            |
| CR102              |           | Diode: crystal<br>Pan Part CR-1N81   | AT<br>CR-1N81       | 1          |               |            |
| DS101              |           | Lamp: incandescent<br>Pan Part B-1007  | AO<br>47            | 1          |               |            |



List of Replaceable Parts for Model SPA-3 (continued)

| Circuit Ref Symbol | Stock No. | Description  | Mfr & Mfrs No.                 | Qty In Set | Qty 3 Mo. Opn | Unit Price |
|--------------------|-----------|--|--------------------------------|------------|---------------|------------|
| DS102              |           | Lamp: incandescent, crt scale miniature bayonet<br>Pan Part B-2042W          | AO<br>51                       | 4          |               |            |
| DS103              |           | Lamp: incandescent, crt scale miniature bayonet<br>Pan Part B-2042W          | AO<br>51                       |            |               |            |
| DS104              |           | Lamp: incandescent, crt scale miniature bayonet<br>Pan Part B-2042W          | AO<br>51                       |            |               |            |
| DS105              |           | Lamp: incandescent, crt scale miniature bayonet<br>Pan Part B-2042W          | AO<br>51                       |            |               |            |
| E101               |           | Lamp: neon<br>Pan Part B2026-M   | AT<br>Type<br>NE-16<br>C1-9064 | 1          |               |            |
| J101               |           | Connector: receptacle<br>BNC, MIL type MG-910/U<br>Pan Part J-2044           | AB<br>31-207                   | 1          |               |            |
| J103               |           | Connector: receptacle<br>5 pin, female contacts<br>Pan Part J-2028           | AB<br>AN3102<br>A-14S-<br>5S   | 1          |               |            |
| J105               |           | Connector: receptacle, BNC<br>D type, MIL type, UG-1094/M<br>Pan Part J-2031 | AB<br>31-221                   | 7          |               |            |
| J107               |           | Connector: receptacle, BNC<br>D type, MIL type, UG-1094/M<br>Pan Part J-2031 | AB<br>31-221                   |            |               |            |

## List of Replaceable Parts for Model SPA-3 (continued)

| Circuit Ref Symbol | Stock No. | Description  | Mfr & Mfrs No.              | Qty In Set | Qty 3 Mo. Opn | Unit Price |
|--------------------|-----------|--|-----------------------------|------------|---------------|------------|
| J109               |           | Jack: telephone<br>two conductor, open circuit<br>Pan Part J-2061            | AD<br>Type JK<br>34C<br>257 | 1          |               |            |
| J111               |           | Connector: receptacle<br>Pan Part J-2035                                     | AK<br>111-103               | 4          |               |            |
| J113               |           | Connector: receptacle<br>10 pin, female contacts<br>Pan Part J-2023          | AB<br>AN3102<br>A-18-1S     | 1          |               |            |
| J117               |           | Connector: receptacle, BNC<br>D type, MIL type, UG-1094/M<br>Pan Part J-2031 | AB<br>31-221                |            |               |            |
| J119               |           | Connector: receptacle<br>D type, MIL type, UG-1094/M<br>Pan Part J-2031      | AB<br>31-221                |            |               |            |
| J121               |           | Connector: receptacle, BNC<br>D type, MIL type, UG-1094/M<br>Pan Part J-2031 | AB<br>31-221                |            |               |            |
| J123               |           | Connector: receptacle, BNC<br>D type, MIL type, UG-1094/M<br>Pan Part J-2031 | AB<br>31-221                |            |               |            |
| J125               |           | Connector: receptacle, BNC<br>D type, MIL type, UG-1094/M<br>Pan Part J-2031 | AB<br>31-221                |            |               |            |
| J130               |           | Connector: receptacle<br>Pan Part J-2035                                     | AK<br>111-103               |            |               |            |
| L101               |           | Choke: r-f<br>6.2 uh, 300 ma<br>Pan Part L-2050                              | AS<br>4610                  | 3          |               |            |

List of Replaceable Parts for Model SPA-3 (continued)

| Circuit Ref Symbol | Stock No. | Description   | Mfr & Mfrs No. | Qty In Set | Qty 3 Mo. Opn | Unit Price |
|--------------------|-----------|---|----------------|------------|---------------|------------|
| L103               |           | Choke: r-f<br>6.2 uh, 300 ma<br>Pan Part L-2050     | AS<br>4610     |            |               |            |
| L105               |           | Choke: r-f<br>6.2 uh, 300 ma<br>Pan Part L-2050     | AS<br>4610     |            |               |            |
| L107               |           | Choke: r-f<br>100 uh<br>Pan Part L-1112             | AX<br>CH-3-3   | 6          |               |            |
| L109               |           | Coil: oscillator<br>29.3 mc<br>Pan Part ZN-8376     | AT<br>Z2-8376  | 1          |               |            |
| L110               |           | Choke: r-f<br>100 uh<br>Pan Part L-1112             | AX<br>CH-3-3   |            |               |            |
| L111               |           | Coil: crystal loading<br>2.7 mc<br>Pan Part ZN-8377 | AT<br>Z2-8377  | 2          |               |            |
| L113               |           | Choke: r-f<br>100 uh<br>Pan Part L-1112             | AX<br>CH-3-3   |            |               |            |
| L115               |           | Choke: r-f<br>100 uh<br>Pan Part L-1112             | AX<br>CH-3-3   |            |               |            |
| L117               |           | Coil: crystal loading<br>2.7 mc<br>Pan Part ZN-8377 | AT<br>Z2-8377  |            |               |            |
| L119               |           | Choke: r-f<br>100 uh<br>Pan Part L-1112             | AX<br>CH-3-3   |            |               |            |

List of Replaceable Parts for Model SPA-3 (continued)

| Circuit Ref Symbol | Stock No. | Description  | Mfr & Mfrs No. | Qty In Set | Qty 3 Mo. Opn | Unit Price |
|--------------------|-----------|--|----------------|------------|---------------|------------|
| L121               |           | Choke: r-f<br>0.8 uh<br>Pan Part L-2051            | AS<br>6175-TV  | 9          |               |            |
| L125               |           | Choke: r-f<br>100 uh<br>Pan Part L-1112            | AX<br>CH-3-3   |            |               |            |
| L127               |           | Inductor: Vari-L<br>32 - 47 mc<br>Pan Part L-2049A | AZ<br>SD-36A   | 1          |               |            |
| L129               |           | Coil: oscillator, variable<br>Pan Part ZN-8375     | AT<br>Z2-8375  | 1          |               |            |
| L130               |           | Choke: r-f<br>0.8 uh<br>Pan Part L-2051            | AS<br>6175-TV  |            |               |            |
| L131               |           | Choke: r-f<br>0.8 uh<br>Pan Part L-2051            | AS<br>6175-TV  |            |               |            |
| L133               |           | Choke: r-f<br>0.8 uh<br>Pan Part L-2051            | AS<br>6175-TV  |            |               |            |
| L135               |           | Choke: r-f<br>0.8 uh<br>Pan Part L-2051            | AS<br>6175-TV  |            |               |            |
| L137               |           | Choke: r-f<br>24 uh, 300 ma<br>Pan Part L-2052     | AS<br>4626     | 2          |               |            |
| L139               |           | Choke: r-f<br>24 uh, 300 ma<br>Pan Part L-2052     | AS<br>4626     |            |               |            |

List of Replaceable Parts for Model SPA-3 (continued)

| Circuit Ref Symbol | Stock No. | Description   | Mfr & Mfrs No.      | Qty In Set | Qty 3 Mo. Opn | Unit Price |
|--------------------|-----------|---|---------------------|------------|---------------|------------|
| L141               |           | Choke: r-f<br>0.8 uh<br>Pan Part L-2051   | AS<br>6175-TV       |            |               |            |
| L143               |           | Choke: r-f<br>0.8 uh<br>Pan Part L-2051   | AS<br>6175-TV       |            |               |            |
| L145               |           | Choke: r-f<br>0.8 uh<br>Pan Part L-2051   | AS<br>6175-TV       |            |               |            |
| L147               |           | Choke: r-f<br>0.8 uh<br>Pan Part L-2051   | AS<br>6175-TV       |            |               |            |
| R101*              |           | Resistor: fixed, metal film<br>79.2 ohms, $\pm 1\%$ , 1/2 W<br>Pan Part RC20AZ79P2F             | AH<br>Type<br>NA-15 | 2          |               |            |
| R101**             |           | Resistor: fixed, metal film<br>55 ohms, $\pm 1\%$ , 1/2 W<br>Pan Part RC20AZ550F                | AH<br>Type<br>NA-15 | 1          |               |            |
| R103*              |           | Resistor: fixed, deposited<br>metal film<br>713 ohms, $\pm 1\%$ , 1/2 W<br>Pan Part RC20AZ7130F | AH<br>Type<br>NA-15 | 4          |               |            |
| R103**             |           | Resistor: fixed, metal film<br>495 ohms, $\pm 1\%$ , 1/2 W<br>Pan Part RC20AZ4950F              | AH<br>Type<br>NA-15 | 4          |               |            |
| R105*              |           | Resistor: fixed, deposited<br>metal film<br>88 ohms, $\pm 1\%$ , 1/2 W<br>Pan Part RC20AZ880F   | AH<br>Type<br>NA-15 | 3          |               |            |

\* 72 ohm input

\*\* 50 ohm input

## List of Replaceable Parts for Model SPA-3 (continued)

| Circuit Ref Symbol | Stock No. | Description   | Mfr & Mfrs No.      | Qty In Set | Qty 3 Mo. Opn | Unit Price |
|--------------------|-----------|---|---------------------|------------|---------------|------------|
| R105**             |           | Resistor: fixed, metal film<br>61 ohms, $\pm 1\%$ , 1/2 W<br>Pan Part RC20AZ610F                | AH<br>Type<br>NA-15 | 4          |               |            |
| R107*              |           | Resistor: fixed, deposited<br>metal film<br>713 ohms, $\pm 1\%$ , 1/2 W<br>Pan Part RC20AZ7130F | AH<br>Type<br>NA-15 |            |               |            |
| R107**             |           | Resistor: fixed, metal film<br>495 ohms, $\pm 1\%$ , 1/2 W<br>Pan Part RC20AZ4950F              | AH<br>Type<br>NA-15 |            |               |            |
| R109*              |           | Resistor: fixed, deposited<br>metal film<br>88 ohms, $\pm 1\%$ , 1/2 W<br>Pan Part RC20AZ880F   | AH<br>Type<br>NA-15 |            |               |            |
| R109**             |           | Resistor: fixed, metal film<br>61 ohms, $\pm 1\%$ , 1/2 W<br>Pan Part RC20AZ610F                | AH<br>Type<br>NA-15 |            |               |            |
| R111*              |           | Resistor: fixed, deposited<br>metal film<br>713 ohms, $\pm 1\%$ , 1/2 W<br>Pan Part RC20AZ7130F | AH<br>Type<br>NA-15 |            |               |            |
| R111**             |           | Resistor: fixed, metal film<br>495 ohms, $\pm 1\%$ , 1/2 W<br>Pan Part RC20AZ4950F              | AH<br>Type<br>NA-15 |            |               |            |
| R113*              |           | Resistor: fixed, deposited<br>metal film<br>88 ohms, $\pm 1\%$ , 1/2 W<br>Pan Part RC20AZ880F   | AH<br>Type<br>NA-15 |            |               |            |
| R113**             |           | Resistor: fixed, metal film<br>61 ohms, $\pm 1\%$ , 1/2 W<br>Pan Part RC20AZ610F                | AH<br>Type<br>NA-15 |            |               |            |

\* 72 ohm input

\*\* 50 ohm input

List of Replaceable Parts for Model SPA-3 (continued)

| Circuit Ref Symbol | Stock No. | Description   | Mfr & Mfrs No.         | Qty In Set | Qty 3 Mo. Opn | Unit Price |
|--------------------|-----------|---|------------------------|------------|---------------|------------|
| R115*              |           | Resistor: fixed, deposited metal film<br>713 ohms, $\pm 1\%$ , 1/2 W<br>Pan Part RC20AZ7130F    | AH<br>Type<br>NA-15    |            |               |            |
| R115**             |           | Resistor: fixed, metal film<br>495 ohms, $\pm 1\%$ , 1/2 W<br>Pan Part RC20AZ4950F              | AH<br>Type<br>NA-15    |            |               |            |
| R117*              |           | Resistor: fixed, metal film<br>79.2 ohms, $\pm 1\%$ , 1/2 W<br>Pan Part RC20AZ79P2F             | AH<br>Type<br>NA-15    |            |               |            |
| R117**             |           | Resistor: fixed, metal film<br>61 ohms, $\pm 1\%$ , 1/2 W<br>Pan Part RC20AZ610F                | AH<br>Type<br>NA-15    |            |               |            |
| R119               |           | Resistor: fixed, composition<br>100,000 ohms, $\pm 5\%$ , 1/2 W<br>Pan Part RC20BX104J          | AA<br>EB1045           | 12         |               |            |
| R121               |           | Resistor: fixed, composition<br>100,000 ohms, $\pm 5\%$ , 1/2 W<br>Pan Part RC20BX104J          | AA<br>EB1045           |            |               |            |
| R123               |           | Resistor: fixed, composition<br>Factory adjust #  |                        |            |               |            |
| R125               |           | Resistor: variable, composition linear<br>5,000 ohms, $\pm 10\%$ , 2 W<br>Pan Part RVA-502AQ-2J | AA<br>RV4NAY<br>SD502A | 2          |               |            |
| R127               |           | Resistor: fixed, composition<br>820 ohms, $\pm 5\%$ , 1/2 W<br>Pan Part RC20BX821J              | AA<br>EB8215           | 1          |               |            |
| R131               |           | Resistor: fixed, composition<br>68,000 ohms, $\pm 5\%$ , 1/2 W<br>Pan Part RC20BX683J           | AA<br>EB6835           | 2          |               |            |

\* 72 ohm input

\*\* 50 ohm input

# for actual value, see schematic diagram.

List of Replaceable Parts for Model SPA-3 (continued)

| Circuit Ref Symbol | Stock No. | Description  | Mfr & Mfrs No. | Qty In Set | Qty 3 Mo. Opn | Unit Price |
|--------------------|-----------|--|----------------|------------|---------------|------------|
| R132               |           | Resistor: fixed, composition<br>33,000 ohms, $\pm 5\%$ , 2 W<br>Pan Part RC42BX333J                                    | AA<br>HB3335   | 2          |               |            |
| R133               |           | Resistor: fixed, composition<br>1,000 ohms, $\pm 5\%$ , 1/2 W<br>Pan Part RC20BX102J                                   | AA<br>EB1025   | 8          |               |            |
| R134               |           | Resistor: fixed, composition<br>33,000 ohms, $\pm 5\%$ , 2 W<br>Pan Part RC42BX333J                                    | AA<br>HB3335   |            |               |            |
| R135               |           | Resistor: fixed, composition<br>100,000 ohms, $\pm 5\%$ , 1/2 W<br>Pan Part RC20BX104J                                 | AA<br>EB1045   |            |               |            |
| R137               |           | Resistor: fixed, composition<br>Factory adjust<br>820 ohms, $\pm 5\%$ , 1/2 W nominal<br>value*<br>Pan Part RC20BX821J | AA<br>EB8215   |            |               |            |
| R139               |           | Resistor: fixed, composition<br>100,000 ohms, $\pm 5\%$ , 1/2 W<br>Pan Part RC20BX104J                                 | AA<br>EB1045   |            |               |            |
| R140               |           | Resistor: fixed, composition<br>100 ohms, $\pm 5\%$ , 1/2 W<br>Pan Part RC20BX101J                                     | AA<br>EB1015   | 10         |               |            |
| R141               |           | Resistor: fixed, composition<br>2,200 ohms, $\pm 5\%$ , 1 W<br>Pan Part RC32BX222J                                     | AA<br>GB2225   | 1          |               |            |
| R143               |           | Resistor: fixed, composition<br>100 ohms, $\pm 5\%$ , 1/2 W<br>Pan Part RC20BX101J                                     | AA<br>EB1015   |            |               |            |

\* for actual value, see schematic diagram.



List of Replaceable Parts for Model SPA-3 (continued)

| Circuit Ref Symbol | Stock No. | Description  | Mfr & Mfrs No.         | Qty In Set | Qty 3 Mo. Opn | Unit Price |
|--------------------|-----------|--|------------------------|------------|---------------|------------|
| R145               |           | Resistor: fixed, composition<br>100,000 ohms, $\pm 5\%$ , 1/2 W<br>Pan Part RC20BX104J             | AA<br>EB1045           |            |               |            |
| R146               |           | Resistor: fixed, composition<br>10 ohms, $\pm 5\%$ , 1/2 W<br>Pan Part RC20BX100J                  | AA<br>EB1005           | 1          |               |            |
| R147               |           | Resistor: fixed, composition<br>1,000 ohms, $\pm 5\%$ , 1/2 W<br>Pan Part RC20BX102J               | AA<br>EB1025           |            |               |            |
| R149               |           | Resistor: fixed, composition<br>1,000 ohms, $\pm 5\%$ , 1/2 W<br>Pan Part RC20BX102J               | AA<br>EB1025           |            |               |            |
| R151               |           | Resistor: fixed, composition<br>200,000 ohms, $\pm 5\%$ , 1/2 W<br>Pan Part RC20BX204J             | AA<br>EB2045           | 3          |               |            |
| R153               |           | Resistor: fixed, composition<br>200,000 ohms, $\pm 5\%$ , 1/2 W<br>Pan Part RC20BX204J             | AA<br>EB2045           |            |               |            |
| R155               |           | Resistor: fixed, composition<br>1,800 ohms, $\pm 5\%$ , 1/2 W<br>Pan Part RC20BX182J               | AA<br>EB1825           | 2          |               |            |
| R157               |           | Resistor: fixed, composition<br>1,800 ohms, $\pm 5\%$ , 1/2 W<br>Pan Part RC20BX182J               | AA<br>EB1825           |            |               |            |
| R159               |           | Resistor: fixed, composition<br>75,000 ohms, $\pm 5\%$ , 1/2 W<br>Pan Part RC20BX753J              | AA<br>EB7535           | 1          |               |            |
| R161               |           | Resistor: variable, composition<br>linear<br>50,000 ohms, $\pm 10\%$ , 2 W<br>Pan Part RVA503AQ-2J | AA<br>RV4NAY<br>SD503A | 4          |               |            |

List of Replaceable Parts for Model SPA-3 (continued)

| Circuit<br>Ref<br>Symbol | Stock<br>No. | Description  | Mfr &<br>Mfrs<br>No.   | Qty<br>In<br>Set | Qty<br>3 Mo.<br>Opn | Unit<br>Price |
|--------------------------|--------------|--|------------------------|------------------|---------------------|---------------|
| R163                     |              | Resistor: fixed, composition<br>24,000 ohms, $\pm 5\%$ , 1/2 W<br>Pan Part RC20BX243J              | AA<br>EB2435           | 1                |                     |               |
| R165                     |              | Resistor: fixed, composition<br>13,000 ohms, $\pm 5\%$ , 1/2 W<br>Pan Part RC20BX133J              | AA<br>EB1335           |                  |                     |               |
| R167                     |              | Resistor: fixed, composition<br>100,000 ohms, $\pm 5\%$ , 1 W<br>Pan Part RC32BX104J               | AA<br>GB1045           | 5                |                     |               |
| R169                     |              | Resistor: fixed, composition<br>2,200 ohms, $\pm 5\%$ , 1/2 W<br>Pan Part RC20BX222J               | AA<br>EB2225           | 5                |                     |               |
| R171                     |              | Resistor: fixed, composition<br>510 ohms, $\pm 5\%$ , 1/2 W<br>Pan Part RC20BX511J                 | AA<br>EB5115           | 2                |                     |               |
| R173                     |              | Resistor: variable, composition<br>linear<br>10,000 ohms, $\pm 10\%$ , 2 W<br>Pan Part RVA103AQ-2J | AA<br>RV4NAY<br>SD103A | 2                |                     |               |
| R175                     |              | Resistor: fixed, composition<br>510 ohms, $\pm 5\%$ , 1/2 W<br>Pan Part RC20BX511J                 | AA<br>EB5115           |                  |                     |               |
| R177                     |              | Resistor: fixed, composition<br>100 ohms, $\pm 5\%$ , 1/2 W<br>Pan Part RC20BX101J                 | AA<br>EB1015           |                  |                     |               |
| R179                     |              | Resistor: fixed, composition<br>1,000 ohms, $\pm 5\%$ , 2 W<br>Pan Part RC42BX102J                 | AA<br>HB1025           | 1                |                     |               |

List of Replaceable Parts for Model SPA-3 (continued)

| Circuit Ref Symbol | Stock No. | Description   | Mfr & Mfrs No.         | Qty In Set | Qty 3 Mo. Opn | Unit Price |
|--------------------|-----------|---|------------------------|------------|---------------|------------|
| R181               |           | Resistor: variable, composition linear<br>1,000 ohms, $\pm 10\%$ , 2 W<br>Pan Part RVA102AQ-2J  | AA<br>RV4NAY<br>SD102A | 1          |               |            |
| R183               |           | Resistor: fixed, composition<br>12 ohms, $\pm 5\%$ , 1/2 W<br>Pan Part RC20BX120J               | AA<br>EB1205           | 1          |               |            |
| R185               |           | Resistor: fixed, composition<br>360 ohms, $\pm 5\%$ , 1/2 W<br>Pan Part RC20BX361J              | AA<br>EB3615           | 1          |               |            |
| R187               |           | Resistor: variable, composition linear<br>10,000 ohms, $\pm 10\%$ , 2 W<br>Pan Part RVA103AQ-2J | AA<br>RV4NAY<br>SD103A |            |               |            |
| R189               |           | Resistor: fixed, composition<br>150,000 ohms, $\pm 5\%$ , 1/2 W<br>Pan Part RC20BX154J          | AA<br>EB1545           | 2          |               |            |
| R191               |           | Resistor: fixed, composition<br>47,000 ohms, $\pm 5\%$ , 1 W<br>Pan Part RC32BX473J             | AA<br>GB4735           | 2          |               |            |
| R193               |           | Resistor: fixed, composition<br>5,600 ohms, $\pm 5\%$ , 1/2 W<br>Pan Part RC20BX562J            | AA<br>EB5625           | 4          |               |            |
| R195               |           | Resistor: fixed, composition<br>100,000 ohms, $\pm 5\%$ , 1/2 W<br>Pan Part RC20BX104J          | AA<br>EB1045           |            |               |            |
| R197               |           | Resistor: fixed, wirewound<br>4.7 ohms, $\pm 10\%$ , 1/2 W<br>Pan Part RCW20AX4P7K              | AQ<br>Type<br>BW-1/2   | 1          |               |            |

List of Replaceable Parts for Model SPA-3 (continued)

| Circuit Ref Symbol | Stock No. | Description  | Mfr & Mfrs No. | Qty In Set | Qty 3 Mo. Opn | Unit Price |
|--------------------|-----------|--|----------------|------------|---------------|------------|
| R199               |           | Resistor: fixed, composition<br>6,200 ohms, $\pm 5\%$ , 1/2 W<br>Pan Part RC20BX622J   | AA<br>EB6225   | 1          |               |            |
| R201               |           | Resistor: fixed, composition<br>18,000 ohms, $\pm 5\%$ , 1 W<br>Pan Part RC32BX183J    | AA<br>GB1835   | 1          |               |            |
| R203               |           | Resistor: fixed, composition<br>22 ohms, $\pm 5\%$ , 1/2 W<br>Pan Part RC20BX220J      | AA<br>EB2205   | 3          |               |            |
| R205               |           | Resistor: fixed, composition<br>3,900 ohms, $\pm 5\%$ , 1/2 W<br>Pan Part RC20BX392J   | AA<br>EB3925   | 1          |               |            |
| R207               |           | Resistor: fixed, composition<br>220 ohms, $\pm 5\%$ , 1/2 W<br>Pan Part RC20BX221J     | AA<br>EB2215   | 1          |               |            |
| R211               |           | Resistor: fixed, composition<br>39,000 ohms, $\pm 5\%$ , 2 W<br>Pan Part RC42BX393J    | AA<br>HB3935   | 1          |               |            |
| R213               |           | Resistor: fixed, composition<br>5,600 ohms, $\pm 5\%$ , 1/2 W<br>Pan Part RC20BX562J   | AA<br>EB5625   |            |               |            |
| R215               |           | Resistor: fixed, composition<br>470,000 ohms, $\pm 5\%$ , 1/2 W<br>Pan Part RC20BX474J | AA<br>EB4745   | 3          |               |            |
| R217               |           | Resistor: fixed, composition<br>390 ohms, $\pm 5\%$ , 1/2 W<br>Pan Part RC20BX391J     | AA<br>EB3915   | 2          |               |            |
| R219               |           | Resistor: fixed, composition<br>100 ohms, $\pm 5\%$ , 1/2 W<br>Pan Part RC20BX101J     | AA<br>EB1015   |            |               |            |

List of Replaceable Parts for Model SPA-3 (continued)

| Circuit Ref Symbol | Stock No. | Description   | Mfr & Mfrs No.          | Qty In Set | Qty 3 Mo. Opn | Unit Price |
|--------------------|-----------|---|-------------------------|------------|---------------|------------|
| R221               |           | Resistor: fixed, composition<br>100 ohms, $\pm 5\%$ , 1/2 W<br>Pan Part RC20BX101J  | AA<br>EB1015            |            |               |            |
| R223               |           | Resistor: fixed, composition<br>1,000 ohms, $\pm 5\%$ , 1/2 W<br>Pan Part RC20BX102J                                      | AA<br>EB1025            |            |               |            |
| R225<br>A, B       |           | Resistor: variable, dual<br>cw log taper<br>10,000 ohms, $\pm 10\%$<br>Pan Part RVB103/103CQ-2J                           | AA<br>JD1N056<br>S103UA |            |               |            |
| R227               |           | Resistor: fixed, composition<br>200,000 ohms, $\pm 5\%$ , 1/2 W<br>Pan Part RC20BX204J                                    | AA<br>EB2045            |            |               |            |
| R228               |           | Resistor: fixed, composition<br>Factory adjust<br>10,000 ohms, $\pm 5\%$ , 1/2 W<br>nominal value*<br>Pan Part RC20BX103J | AA<br>EB1035            |            |               |            |
| R229               |           | Resistor: fixed, composition<br>150,000 ohms, $\pm 5\%$ , 1/2 W<br>Pan Part RC20BX154J                                    | AA<br>EB1545            |            |               |            |
| R230               |           | Resistor: fixed, composition<br>5,100 ohms, $\pm 5\%$ , 1/2 W<br>Pan Part RC20BX512J                                      | AA<br>EB5125            | 1          |               |            |
| R231               |           | Resistor: fixed, composition<br>160 ohms, $\pm 5\%$ , 1/2 W<br>Pan Part RC20BX161J  | AA<br>EB1615            | 3          |               |            |
| R233               |           | Resistor: fixed, composition<br>1,000 ohms, $\pm 5\%$ , 1/2 W<br>Pan Part RC20BX102J                                      | AA<br>EB1025            |            |               |            |

\*for actual value, see schematic diagram.

## List of Replaceable Parts for Model SPA-3 (continued)

| Circuit Ref Symbol | Stock No. | Description   | Mfr & Mfrs No. | Qty In Set | Qty 3 Mo. Opn | Unit Price |
|--------------------|-----------|---|----------------|------------|---------------|------------|
| R235               |           | Resistor: fixed, composition<br>100,000 ohms, $\pm 5\%$ , 1/2 W<br>Pan Part RC20BX104J                                    | AA<br>EB1045   |            |               |            |
| R237               |           | Resistor: fixed, composition<br>390 ohms, $\pm 5\%$ , 1/2 W<br>Pan Part RC20BX391J  | AA<br>EB3915   |            |               |            |
| R239               |           | Resistor: fixed, composition<br>100 ohms, $\pm 5\%$ , 1/2 W<br>Pan Part RC20BX101J  | AA<br>EB1015   |            |               |            |
| R241               |           | Resistor: fixed, composition<br>100 ohms, $\pm 5\%$ , 1/2 W<br>Pan Part RC20BX101J  | AA<br>EB1015   |            |               |            |
| R243               |           | Resistor: fixed, composition<br>1,000 ohms, $\pm 5\%$ , 1/2 W<br>Pan Part RC20BX102J                                      | AA<br>EB1025   |            |               |            |
| R245               |           | Resistor: fixed, composition<br>Factory adjust<br>10,000 ohms, $\pm 5\%$ , 1/2 W<br>nominal value*<br>Pan Part RC20BX103J | AA<br>EB1035   |            |               |            |
| R247               |           | Resistor: fixed, composition<br>2,200 ohms, $\pm 5\%$ , 1/2 W<br>Pan Part RC20BX222J                                      | AA<br>EB2225   |            |               |            |
| R249               |           | Resistor: fixed, composition<br>120,000 ohms, $\pm 5\%$ , 1/2 W<br>Pan Part RC20BX124J                                    | AA<br>EB1245   | 1          |               |            |
| R251               |           | Resistor: fixed, composition<br>160 ohms, $\pm 5\%$ , 1/2 W<br>Pan Part RC20BX161J  | AA<br>EB1615   |            |               |            |

\*for actual value, see schematic diagram.

List of Replaceable Parts for Model SPA-3 (continued)

| Circuit Ref Symbol | Stock No. | Description   | Mfr & Mfrs No.         | Qty In Set | Qty 3 Mo. Opn | Unit Price |
|--------------------|-----------|---|------------------------|------------|---------------|------------|
| R253               |           | Resistor: fixed, composition<br>160 ohms, $\pm 5\%$ , 1/2 W<br>Pan Part RC20BX161J                                      | AA<br>EB1615           |            |               |            |
| R255               |           | Resistor: fixed, composition<br>100,000 ohms, $\pm 5\%$ , 1/2 W<br>Pan Part RC20BX104J                                  | AA<br>EB1045           |            |               |            |
| R257               |           | Resistor: fixed, composition<br>100 ohms, $\pm 5\%$ , 1/2 W<br>Pan Part RC20BX101J                                      | AA<br>EB1015           |            |               |            |
| R259               |           | Resistor: fixed, composition<br>100 ohms, $\pm 5\%$ , 1/2 W<br>Pan Part RC20BX101J                                      | AA<br>EB1015           |            |               |            |
| R261               |           | Resistor: variable, composition<br>linear<br>50,000 ohms, $\pm 10\%$ , 2 W<br>Pan Part RVA503AQ-2J                      | AA<br>RV4NAY<br>SD503A |            |               |            |
| R263               |           | Resistor: fixed, composition<br>Factory adjust<br>43,000 ohms, $\pm 5\%$ , 1 W<br>nominal value*<br>Pan Part RC32BX433J | AA<br>GB4335           |            |               |            |
| R265               |           | Resistor: fixed, composition<br>33,000 ohms, $\pm 5\%$ , 1 W<br>Pan Part RC32BX333J                                     | AA<br>GB3335           | 1          |               |            |
| R267               |           | Resistor: fixed, composition<br>5,600 ohms, $\pm 5\%$ , 1 W<br>Pan Part RC32BX562J                                      | AA<br>GB5625           | 2          |               |            |
| R269               |           | Resistor: fixed, composition<br>47,000 ohms, $\pm 5\%$ , 2W<br>Pan Part RC42BX473J                                      | AA<br>HB4735           | 1          |               |            |

\*for actual value, see schematic diagram.

List of Replaceable Parts for Model SPA-3 (continued)

| Circuit Ref Symbol | Stock No. | Description   | Mfr & Mfrs No.         | Qty In Set | Qty 3 Mo. Opn | Unit Price |
|--------------------|-----------|---|------------------------|------------|---------------|------------|
| R271               |           | Resistor: fixed, composition<br>5,600 ohms, $\pm 5\%$ , 1 W<br>Pan Part RC32BX562J                  | AA<br>GB5625           |            |               |            |
| R273               |           | Resistor: fixed, composition<br>20,000 ohms, $\pm 5\%$ , 1/2 W<br>Pan Part RC20BX203J               | AA<br>EB2035           | 2          |               |            |
| R275               |           | Resistor: fixed, composition<br>1 megohm, $\pm 5\%$ , 1/2 W<br>Pan Part RC20BX105J                  | AA<br>EB1055           | 7          |               |            |
| R277               |           | Resistor: fixed, composition<br>750 ohms, $\pm 5\%$ , 1/2 W<br>Pan Part RC20BX751J                  | AA<br>EB7515           |            |               |            |
| R278               |           | Resistor: fixed, composition<br>68,000 ohms, $\pm 5\%$ , 1/2 W<br>Pan Part RC20BX683J               | AA<br>EB6835           |            |               |            |
| R279               |           | Resistor: variable, composition<br>linear<br>100,000 ohms, $\pm 10\%$ , 2 W<br>Pan Part RVA104AQ-2J | AA<br>RV4NAY<br>SD104A | 2          |               |            |
| R281               |           | Resistor: fixed, composition<br>11,000 ohms, $\pm 5\%$ , 1/2 W<br>Pan Part RC20BX113J               | AA<br>EB1135           | 1          |               |            |
| R283               |           | Resistor: fixed, composition<br>220,000 ohms, $\pm 5\%$ , 1/2 W<br>Pan Part RC20BX224J              | AA<br>EB2245           | 5          |               |            |
| R285               |           | Resistor: fixed, composition<br>680,000 ohms, $\pm 5\%$ , 1/2 W<br>Pan Part RC20BX684J              | AA<br>EB6845           | 1          |               |            |
| R287               |           | Resistor: fixed, composition<br>100,000 ohms, $\pm 5\%$ , 1/2 W<br>Pan Part RC20BX104J              | AA<br>EB1045           |            |               |            |



List of Replaceable Parts for Model SPA-3 (continued)

| Circuit Ref Symbol | Stock No. | Description  | Mfr & Mfrs No.         | Qty In Set | Qty 3 Mo. Opn | Unit Price |
|--------------------|-----------|--|------------------------|------------|---------------|------------|
| R289               |           | Resistor: fixed, composition<br>2,200 ohms, $\pm 5\%$ , 1/2 W<br>Pan Part RC20BX222J                                       | AA<br>EB2225           |            |               |            |
| R291               |           | Resistor: fixed, composition<br>4,700 ohms, $\pm 5\%$ , 1/2 W<br>Pan Part RC20BX472J                                       | AA<br>EB4725           | 1          |               |            |
| R293               |           | Resistor: fixed, composition<br>100,000 ohms, $\pm 5\%$ , 1/2 W<br>Pan Part RC20BX104J                                     | AA<br>EB1045           |            |               |            |
| R295               |           | Resistor: fixed, composition<br>150,000 ohms, $\pm 5\%$ , 1/2 W<br>Pan Part RC20BX154J                                     | AA<br>EB1545           |            |               |            |
| R297               |           | Resistor: fixed, composition<br>2,200 ohms, $\pm 5\%$ , 1/2 W<br>Pan Part RC20BX222J                                       | AA<br>EB2225           |            |               |            |
| R299               |           | Resistor: fixed, composition<br>2,200 ohms, $\pm 5\%$ , 1/2 W<br>Pan Part RC20BX222J                                       | AA<br>EB2225           |            |               |            |
| R301               |           | Resistor: fixed, composition<br>220,000 ohms, $\pm 5\%$ , 1/2 W<br>Pan Part RC20BX224J                                     | AA<br>EB2245           |            |               |            |
| R303               |           | Resistor: fixed, composition<br>1 megohm, $\pm 5\%$ , 1/2 W<br>Pan Part RC20BX105J   | AA<br>EB1055           |            |               |            |
| R305               |           | Resistor: fixed, composition<br>4,300 ohms, $\pm 5\%$ , 1/2 W<br>Pan Part RC20BX432J                                       | AA<br>EB4325           | 1          |               |            |
| R307               |           | Resistor: variable, composition<br>linear (includes switch S107)<br>5 megohms, $\pm 20\%$ , 2 W<br>Pan Part RVA505BQ-2J-S1 | AA<br>RV4NBY<br>SD505B | 1          |               |            |

## List of Replaceable Parts for Model SPA-3 (continued)

| Circuit Ref Symbol | Stock No. | Description   | Mfr & Mfrs No.         | Qty In Set | Qty 3 Mo. Opn | Unit Price |
|--------------------|-----------|---|------------------------|------------|---------------|------------|
| R309               |           | Resistor: fixed, composition<br>4.7 megohms, $\pm 5\%$ , 1/2 W<br>Pan Part RC20BX475J               | AA<br>EB4755           | 1          |               |            |
| R311               |           | Resistor: fixed, composition<br>100,000 ohms, $\pm 5\%$ , 1 W<br>Pan Part RC20BX104J                | AA<br>GB1045           |            |               |            |
| R313               |           | Resistor: fixed, composition<br>620 ohms, $\pm 5\%$ , 1/2 W<br>Pan Part RC20BX621J                  | AA<br>EB6215           | 1          |               |            |
| R315               |           | Resistor: fixed, composition<br>120 ohms, $\pm 5\%$ , 1/2 W<br>Pan Part RC20BX121J                  | AA<br>EB1215           | 1          |               |            |
| R317               |           | Resistor: fixed, composition<br>100,000 ohms, $\pm 5\%$ , 1 W<br>Pan Part RC20BX104J                | AA<br>GB1045           |            |               |            |
| R319               |           | Resistor: fixed, composition<br>1.2 megohms, $\pm 5\%$ , 1/2 W<br>Pan Part RC20BX125J               | AA<br>EB1255           | 1          |               |            |
| R321               |           | Resistor: fixed, composition<br>160,000 ohms, $\pm 5\%$ , 1/2 W<br>Pan Part RC20BX164J              | AA<br>EB1645           | 1          |               |            |
| R323               |           | Resistor: fixed, composition<br>5,600 ohms, $\pm 5\%$ , 1/2 W<br>Pan Part RC20BX562J                | AA<br>EB5625           |            |               |            |
| R325               |           | Resistor: variable, composition<br>linear<br>500,000 ohms, $\pm 10\%$ , 2 W<br>Pan Part RVA504AQ-2J | AA<br>RV4NAY<br>SD504A | 3          |               |            |
| R327               |           | Resistor: fixed, composition<br>68,000 ohms, $\pm 5\%$ , 1 W<br>Pan Part RC32BX683J                 | AA<br>GB6835           | 1          |               |            |

List of Replaceable Parts for Model SPA-3 (continued)

| Circuit Ref Symbol | Stock No. | Description   | Mfr & Mfrs No.         | Qty In Set | Qty 3 Mo. Opn | Unit Price |
|--------------------|-----------|---|------------------------|------------|---------------|------------|
| R329               |           | Resistor: fixed, composition<br>150,000 ohms, $\pm 5\%$ , 1 W<br>Pan Part RC32BX153J  | AA<br>GB1535           | 1          |               |            |
| R331               |           | Resistor: fixed, composition<br>470,000 ohms, $\pm 5\%$ , 1/2 W<br>Pan Part RC20BX474J                                      | AA<br>EB4745           |            |               |            |
| R333               |           | Resistor: fixed, composition<br>100,000 ohms, $\pm 5\%$ , 1/2 W<br>Pan Part RC20BX104J                                      | AA<br>EB1045           |            |               |            |
| R335               |           | Resistor: fixed, composition<br>1 megohm, $\pm 5\%$ , 1/2 W<br>Pan Part RC20BX105J  | AA<br>EB1055           |            |               |            |
| R337               |           | Resistor: variable, composition<br>linear (includes switch S104)<br>1,000 ohms, $\pm 10\%$ , 2 W<br>Pan Part RVA102AQ-2J-S1 | AA<br>RV4NBY<br>SD102A | 1          |               |            |
| R339               |           | Resistor: fixed, wirewound<br>radial leads<br>2,000 ohms, $\pm 10\%$ , 10 W<br>Pan Part RW10X202R-4                         | AY<br>FRL-10           | 1          |               |            |
| R341               |           | Resistor: fixed, composition<br>Factory adjust<br>91,000 ohms, $\pm 5\%$ , 1/2 W<br>nominal value*<br>Pan Part RC20BX913J   | AA<br>EB9135           |            |               |            |
| R345               |           | Resistor: variable, composition<br>linear<br>250,000 ohms, $\pm 10\%$ , 2 W<br>Pan Part RVA254AQ-2J                         | AA<br>RV4NAY<br>SD254A | 1          |               |            |
| R347               |           | Resistor: fixed, composition<br>240,000 ohms, $\pm 5\%$ , 1/2 W<br>Pan Part RC20BX244J                                      | AA<br>EB2445           | 1          |               |            |

\*for actual value, see schematic diagram.

List of Replaceable Parts for Model SPA-3 (continued)

| Circuit Ref Symbol | Stock No. | Description  | Mfr & Mfrs No.          | Qty In Set | Qty 3 Mo. Opn | Unit Price |
|--------------------|-----------|--|-------------------------|------------|---------------|------------|
| R349               |           | Resistor: variable, composition clockwise, log A taper<br>100,000 ohms, $\pm 10\%$ , 2 W<br>Pan Part RVA104CI-2J | AA<br>JA4N048<br>P104AA | 1          |               |            |
| R351               |           | Resistor: fixed, composition<br>200 ohms, $\pm 5\%$ , 1 W<br>Pan Part RC32BX201J                                 | AA<br>GB2015            | 1          |               |            |
| R353               |           | Resistor: variable, composition linear<br>300 ohms, $\pm 10\%$ , 2 W<br>Pan Part RVA301AQ-2J                     | AA<br>JA1N056<br>S301UA | 1          |               |            |
| R355               |           | Resistor: fixed, composition<br>51 ohms, $\pm 5\%$ , 1 W<br>Pan Part RC32BX510J                                  | AA<br>GB5105            | 1          |               |            |
| R357               |           | Resistor: fixed, composition<br>15,000 ohms, $\pm 5\%$ , 1/2 W<br>Pan Part RC20BX153J                            | AA<br>EB1535            | 2          |               |            |
| R359               |           | Resistor: fixed, composition<br>51,000 ohms, $\pm 5\%$ , 1/2 W<br>Pan Part RC20BX513J                            | AA<br>EB5135            | 3          |               |            |
| R361               |           | Resistor: fixed, composition<br>51,000 ohms, $\pm 5\%$ , 1/2 W<br>Pan Part RC20BX513J                            | AA<br>EB5135            |            |               |            |
| R363               |           | Resistor: fixed, composition<br>22 ohms, $\pm 5\%$ , 1/2 W<br>Pan Part RC20BX220J                                | AA<br>EB2205            |            |               |            |
| R365               |           | Resistor: fixed, composition<br>390,000 ohms, $\pm 5\%$ , 1/2 W<br>Pan Part RC20BX394J                           | AA<br>EB3945            | 1          |               |            |

List of Replaceable Parts for Model SPA-3 (continued)

| Circuit Ref Symbol | Stock No. | Description  | Mfr & Mfrs No. | Qty In Set | Qty 3 Mo. Opn | Unit Price |
|--------------------|-----------|--|----------------|------------|---------------|------------|
| R367               |           | Resistor: fixed, composition<br>240 ohms, $\pm 5\%$ , 1/2 W<br>Pan Part RC20BX241J     | AA<br>EB2415   | 1          |               |            |
| R369               |           | Resistor: fixed, composition<br>3,300 ohms, $\pm 5\%$ , 1/2 W<br>Pan Part RC20BX332J   | AA<br>EB3325   | 3          |               |            |
| R371               |           | Resistor: fixed, composition<br>3,300 ohms, $\pm 5\%$ , 1/2 W<br>Pan Part RC20BX332J   | AA<br>EB3325   |            |               |            |
| R373               |           | Resistor: fixed, composition<br>3,300 ohms, $\pm 5\%$ , 1/2 W<br>Pan Part RC20BX332J   | AA<br>EB3325   |            |               |            |
| R375               |           | Resistor: fixed, composition<br>100,000 ohms, $\pm 5\%$ , 1/2 W<br>Pan Part RC20BX104J | AA<br>EB1045   |            |               |            |
| R377               |           | Resistor: fixed, composition<br>1 megohm, $\pm 5\%$ , 1/2 W<br>Pan Part RC20BX105J     | AA<br>EB1055   |            |               |            |
| R379               |           | Resistor: fixed, composition<br>1 megohm, $\pm 5\%$ , 1/2 W<br>Pan Part RC20BX105J     | AA<br>EB1055   |            |               |            |
| R381               |           | Resistor: fixed, composition<br>1,000 ohms, $\pm 5\%$ , 1/2 W<br>Pan Part RC20BX102J   | AA<br>EB1025   |            |               |            |
| R385               |           | Resistor: fixed, composition<br>1 megohm, $\pm 5\%$ , 1/2 W<br>Pan Part RC20BX105J     | AA<br>EB1055   |            |               |            |
| R387               |           | Resistor: fixed, composition<br>220,000 ohms, $\pm 5\%$ , 1/2 W<br>Pan Part RC20BX224J | AA<br>EB2245   |            |               |            |

List of Replaceable Parts for Model SPA-3 (continued)

| Circuit Ref Symbol | Stock No. | Description  | Mfr & Mfrs No.          | Qty In Set | Qty 3 Mo. Opn | Unit Price |
|--------------------|-----------|--|-------------------------|------------|---------------|------------|
| R389               |           | Resistor: fixed, composition<br>3,000 ohms, $\pm 5\%$ , 1/2 W<br>Pan Part RC20BX302J                       | AA<br>EB3025            | 1          |               |            |
| R391               |           | Resistor: variable, composition<br>linear<br>50,000 ohms, $\pm 10\%$ , 2 W<br>Pan Part RVA503AQ-2J         | AA<br>RV4NAY<br>SD503A  |            |               |            |
| R393               |           | Resistor: fixed, composition<br>100,000 ohms, $\pm 5\%$ , 1 W<br>Pan Part RC20BX104J                       | AA<br>GB1045            |            |               |            |
| R395               |           | Resistor: fixed, composition<br>20,000 ohms, $\pm 5\%$ , 1/2 W<br>Pan Part RC20BX203J                      | AA<br>EB2035            |            |               |            |
| R397               |           | Resistor: fixed, composition<br>470,000 ohms, $\pm 5\%$ , 1/2 W<br>Pan Part RC20BX474J                     | AA<br>EB4745            |            |               |            |
| R399               |           | Resistor: fixed, composition<br>820,000 ohms, $\pm 5\%$ , 1/2 W<br>Pan Part RC20BX824J                     | AA<br>EB8245            | 1          |               |            |
| R401<br>A, B       |           | Resistor: variable, dual, linear<br>50,000 ohms/5 megohms,<br>$\pm 10\%$ , 2 W<br>Pan Part RVB503/505BQ-2J | AA<br>JJU-50<br>32/5052 | 1          |               |            |
| R403               |           | Resistor: fixed, composition<br>47,000 ohms, $\pm 5\%$ , 1 W<br>Pan Part RC32BX473J                        | AA<br>GB4735            |            |               |            |
| R405               |           | Resistor: fixed, composition<br>15,000 ohms, $\pm 5\%$ , 1 W<br>Pan Part RC32BX153J                        | AA<br>GB1535            | 2          |               |            |

List of Replaceable Parts for Model SPA-3 (continued)

| Circuit Ref Symbol | Stock No. | Description   | Mfr & Mfrs No.         | Qty In Set | Qty 3 Mo. Opn | Unit Price |
|--------------------|-----------|---|------------------------|------------|---------------|------------|
| R407               |           | Resistor: fixed, composition<br>15,000 ohms, $\pm 5\%$ , 1 W<br>Pan Part RC32BX153J                 | AA<br>GB1535           |            |               |            |
| R409               |           | Resistor: fixed, composition<br>51,000 ohms, $\pm 5\%$ , 1/2 W<br>Pan Part RC20BX513J               | AA<br>EB5135           |            |               |            |
| R411               |           | Resistor: variable, composition<br>linear<br>100,000 ohms, $\pm 10\%$ , 2 W<br>Pan Part RVA104AQ-2J | AA<br>RV4NAY<br>SD104A |            |               |            |
| R413               |           | Resistor: fixed, composition<br>30,000 ohms, $\pm 5\%$ , 1/2 W<br>Pan Part RC20BX303J               | AA<br>EB3035           | 1          |               |            |
| R415               |           | Resistor: variable, composition<br>linear<br>500,000 ohms, $\pm 10\%$ , 2 W<br>Pan Part RVA504AQ-2J | AA<br>RV4NAY<br>SD504A |            |               |            |
| R417               |           | Resistor: variable, composition<br>linear<br>500,000 ohms, $\pm 10\%$ , 2 W<br>Pan Part RVA504AQ-2J | AA<br>RV4NAY<br>SD504A |            |               |            |
| R419               |           | Resistor: fixed, composition<br>750,000 ohms, $\pm 5\%$ , 1/2 W<br>Pan Part RC20BX754J              | AA<br>EB7545           | 1          |               |            |
| R421               |           | Resistor: variable, composition<br>linear<br>1 megohm, $\pm 20\%$ , 2 W<br>Pan Part RVA105BQ-2J     | AA<br>RV4NAY<br>SD105B | 1          |               |            |
| R423               |           | Resistor: fixed, composition<br>100,000 ohms, $\pm 5\%$ , 1/2 W<br>Pan Part RC20BX104J              | AA<br>EB1045           |            |               |            |

List of Replaceable Parts for Model SPA-3 (continued)

| Circuit Ref Symbol | Stock No. | Description  | Mfr & Mfrs No.         | Qty In Set | Qty 3 Mo. Opn | Unit Price |
|--------------------|-----------|--|------------------------|------------|---------------|------------|
| R425               |           | Resistor: fixed, composition<br>1 megohm, $\pm 5\%$ , 1/2 W<br>Pan Part RC20BX105J                 | AA<br>EB1055           |            |               |            |
| R427               |           | Resistor: fixed, composition<br>100,000 ohms, $\pm 5\%$ , 1 W<br>Pan Part RC20BX104J               | AA<br>GB1045           |            |               |            |
| R429               |           | Resistor: fixed, composition<br>10,000 ohms, $\pm 5\%$ , 1/2 W<br>Pan Part RC20BX103J              | AA<br>EB1035           | 1          |               |            |
| R431               |           | Resistor: variable, composition<br>linear<br>5,000 ohms, $\pm 10\%$ , 2 W<br>Pan Part RVA-502AQ-2J | AA<br>RV4NAY<br>SD502A |            |               |            |
| R433               |           | Resistor: fixed, composition<br>1,000 ohms, $\pm 5\%$ , 1/2 W<br>Pan Part RC20BX102J               | AA<br>EB1025           |            |               |            |
| R435               |           | Resistor: fixed, composition<br>220,000 ohms, $\pm 5\%$ , 1/2 W<br>Pan Part RC20BX224J             | AA<br>EB2245           |            |               |            |
| R437               |           | Resistor: fixed, composition<br>1.8 megohms, $\pm 5\%$ , 1/2 W<br>Pan Part RC20BX185J              | AA<br>EB1855           | 1          |               |            |
| R439               |           | Resistor: fixed, composition<br>180,000 ohms, $\pm 5\%$ , 1/2 W<br>Pan Part RC20BX184J             | AA<br>EB1845           | 1          |               |            |
| R441               |           | Resistor: fixed, composition<br>75,000 ohms, $\pm 5\%$ , 2 W<br>Pan Part RC42BX753J                | AA<br>HB7535           | 1          |               |            |
| R443               |           | Resistor: fixed, composition<br>5,600 ohms, $\pm 5\%$ , 1/2 W<br>Pan Part RC20BX562J               | AA<br>EB5625           |            |               |            |



List of Replaceable Parts for Model SPA-3 (continued)

| Circuit Ref Symbol | Stock No. | Description   | Mfr & Mfrs No.         | Qty In Set | Qty 3 Mo. Opn | Unit Price |
|--------------------|-----------|---|------------------------|------------|---------------|------------|
| R444               |           | Resistor: fixed, composition<br>47,000 ohms, $\pm 5\%$ , 1/2 W<br>Pan Part RC20BX473J                             | AA<br>EB4735           | 2          |               |            |
| R445               |           | Resistor: fixed, composition<br>220,000 ohms, $\pm 5\%$ , 1/2 W<br>Pan Part RC20BX224J                            | AA<br>EB2245           |            |               |            |
| R446               |           | Resistor: fixed, composition<br>47,000 ohms, $\pm 5\%$ , 1/2 W<br>Pan Part RC20BX473J                             | AA<br>EB4735           |            |               |            |
| R447               |           | Resistor: fixed, composition<br>24,000 ohms, $\pm 5\%$ , 1 W<br>Pan Part RC32BX243J                               | AA<br>GB2435           | 1          |               |            |
| R449               |           | Resistor: variable, composition<br>linear<br>50,000 ohms, $\pm 10\%$ , 2 W<br>Pan Part RVA503AQ-2J                | AA<br>RV4NAY<br>SD503A |            |               |            |
| R451               |           | Resistor: fixed, composition<br>75,000 ohms, $\pm 5\%$ , 1 W<br>Pan Part RC32BX753J                               | AA<br>GB7535           | 1          |               |            |
| R453               |           | Resistor: fixed, composition<br>430,000 ohms, $\pm 5\%$ , 1/2 W<br>Pan Part RC20BX434J                            | AA<br>EB4345           | 1          |               |            |
| R455               |           | Resistor: variable, composition<br>linear, high voltage<br>100,000 ohms, $\pm 10\%$ , 2 W<br>Pan Part RVAH104BI-3 | AG<br>CM-8340          | 1          |               |            |
| R457               |           | Resistor: fixed, composition<br>270,000 ohms, $\pm 5\%$ , 1 W<br>Pan Part RC32BX274J                              | AA<br>GB2745           | 1          |               |            |

List of Replaceable Parts for Model SPA-3 (continued)

| Circuit Ref Symbol | Stock No. | Description   | Mfr & Mfrs No.          | Qty In Set | Qty 3 Mo. Opn | Unit Price |
|--------------------|-----------|---|-------------------------|------------|---------------|------------|
| R459               |           | Resistor: variable, composition linear, high voltage<br>500,000 ohms, $\pm 10\%$ , 2 W<br>Pan Part RVAH504BI-3    | AG<br>CM-8339           | 1          |               |            |
| R461               |           | Resistor: fixed, composition<br>470,000 ohms, $\pm 5\%$ , 1 W<br>Pan Part RC32BX474J                              | AA<br>GB4745            | 2          |               |            |
| R463               |           | Resistor: fixed, composition<br>470,000 ohms, $\pm 5\%$ , 1 W<br>Pan Part RC32BX474J                              | AA<br>GB4745            |            |               |            |
| R465               |           | Resistor: fixed, composition<br>2,000 ohms, $\pm 5\%$ , 1/2 W<br>Pan Part RC20BX202J                              | AA<br>EB2025            | 2          |               |            |
| R467               |           | Resistor: fixed, composition<br>2,000 ohms, $\pm 5\%$ , 1/2 W<br>Pan Part RC20BX202J                              | AA<br>EB2025            |            |               |            |
| R469               |           | Resistor: variable, wirewound linear (includes switch S106)<br>6 ohms, $\pm 10\%$ , 2 W<br>Pan Part RVW060BI-1-S1 | AT<br>RVW060<br>BI-1-S1 | 1          |               |            |
| S101               |           | Switch: rotary, ceramic wafer single section, 5 position, 2 pole<br>Pan Part S1-10746                             | AT<br>S1-10746          | 1          |               |            |
| S102               |           | Switch: toggle<br>SPDT, bat handle<br>Pan Part S-2043   | AC<br>81021-AV          | 1          |               |            |
| S103               |           | Switch: rotary, ceramic wafer single section, 3 pole, 3 throw<br>Pan Part S-2013                                  | AT<br>S1-2013           | 2          |               |            |

List of Replaceable Parts for Model SPA-3 (continued)

| Circuit Ref Symbol | Stock No. | Description   | Mfr & Mfrs No. | Qty In Set | Qty 3 Mo. Opn | Unit Price |
|--------------------|-----------|---|----------------|------------|---------------|------------|
| S104               |           | Switch: SPST<br>See R337  |                |            |               |            |
| S105               |           | Switch: rotary, ceramic wafer<br>single section, 3 pole, 3 throw<br>Pan Part S-2013 | AT<br>S1-2013  |            |               |            |
| S106               |           | Switch: SPST<br>See R469  |                |            |               |            |
| S107               |           | Switch: SPST<br>See R307  |                |            |               |            |
| T101               |           | Transformer: I-F<br>32 mc<br>Pan Part ZN-8373                                       | AT<br>Z2-8373  | 1          |               |            |
| T102               |           | Transformer: I-F<br>32 mc<br>Pan Part ZN-8374                                       | AT<br>Z2-8374  | 1          |               |            |
| T103               |           | Transformer: I-F<br>32 mc<br>Pan Part ZN-8378                                       | AT<br>Z2-8378  | 1          |               |            |
| T104               |           | Transformer: I-F<br>2.7 mc<br>Pan Part ZN-8379                                      | AT<br>Z2-8379  | 3          |               |            |
| T105               |           | Transformer: I-F<br>2.7 mc<br>Pan Part ZN-8379                                      | AT<br>Z2-8379  |            |               |            |
| T106               |           | Transformer: I-F<br>2.7 mc<br>Pan Part ZN-8379                                      | AT<br>Z2-8379  |            |               |            |
| V101               |           | Electron Tube: 6J4<br>Pan Part 6J4  | BA<br>6J4      | 2          |               |            |

List of Replaceable Parts for Model SPA-3 (continued)

| Circuit Ref Symbol | Stock No. | Description                            | Mfr & Mfrs No. | Qty In Set | Qty 3 Mo. Opn | Unit Price |
|--------------------|-----------|--|----------------|------------|---------------|------------|
| V102               |           | Electron Tube: 6J4<br>Pan Part 6J4     | BA<br>6J4      |            |               |            |
| V103               |           | Electron Tube: 6J6<br>Pan Part 6J6     | BA<br>6J6      | 2          |               |            |
| V104               |           | Electron Tube: 5879<br>Pan Part 5879   | BA<br>5879     | 2          |               |            |
| V105               |           | Electron Tube: 5879<br>Pan Part 5879   | BA<br>5879     |            |               |            |
| V106               |           | Electron Tube: 6AW8A<br>Pan Part 6AW8A | BA<br>6AW8A    | 2          |               |            |
| V107               |           | Electron Tube: 6BE6<br>Pan Part 6BE6   | BA<br>6BE6     | 1          |               |            |
| V108               |           | Electron Tube: 6AB4<br>Pan Part 6AB4   | BA<br>6AB4     | 1          |               |            |
| V109               |           | Electron Tube: 6AW8A<br>Pan Part 6AW8A | BA<br>6AW8A    |            |               |            |
| V110               |           | Electron Tube: 6BC6<br>Pan Part 6BC6   | BA<br>6BC6     | 1          |               |            |
| V111               |           | Electron Tube: 6AU6<br>Pan Part 6AU6   | BA<br>6AU6     | 1          |               |            |
| V112               |           | Electron Tube: 12AU7<br>Pan Part 12AU7 | BA<br>12AU7    | 3          |               |            |
| V113               |           | Electron Tube: 12AT7<br>Pan Part 12AT7 | BA<br>12AT7    | 2          |               |            |
| V114               |           | Electron Tube: 12AU7<br>Pan Part 12AU7 | BA<br>12AU7    |            |               |            |

List of Replaceable Parts for Model SPA-3 (continued)

| Circuit Ref Symbol | Stock No. | Description  | Mfr & Mfrs No.    | Qty In Set | Qty 3 Mo. Opn | Unit Price |
|--------------------|-----------|--|-------------------|------------|---------------|------------|
| V115               |           | Electron Tube: 12AX7<br>Pan Part 12AX7                       | BA<br>12AX7       | 1          |               |            |
| V116               |           | Electron Tube: OA2<br>Pan Part OA2                           | BA<br>OA2         | 1          |               |            |
| V117               |           | Electron Tube: 12BY7<br>Pan Part 12BY7                       | BA<br>12BY7       | 1          |               |            |
| V118               |           | Electron Tube: 6BK7A<br>Pan Part 6BK7A                       | BA<br>6BK7A       | 1          |               |            |
| V119               |           | Electron Tube: 6J6<br>Pan Part 6J6                           | BA<br>6J6         |            |               |            |
| V120               |           | Electron Tube: 12AT7<br>Pan Part 12AT7                       | BA<br>12AT7       |            |               |            |
| V121               |           | Electron Tube: 6U8<br>Pan Part 6U8                           | BA<br>6U8         | 1          |               |            |
| V122               |           | Electron Tube: 12AU7<br>Pan Part 12AU7                       | BA<br>12AU7       |            |               |            |
| V123               |           | Electron Tube: 5ADP7<br>Pan Part 5ADP7                       | BA<br>5ADP7       | 1          |               |            |
| Y101               |           | Crystal: quartz<br>29.300 mc, $\pm$ .005%<br>Pan Part Y-3014 | AT<br>Y-3014      | 1          |               |            |
| Y102*              |           | Crystal: quartz<br>2.700 mc, $\pm$ .005%<br>Pan Part 2Y3015M | AT<br>2Y3015<br>M | 2          |               |            |
| Y103*              |           | Crystal: quartz<br>2.700 mc, $\pm$ .005%<br>Pan Part 2Y3015M | AT<br>2Y3015<br>M |            |               |            |

\*Supplied as a matched pair, Panoramic Part No. 2Y3015M

List of Replaceable Parts for Model SPA-3 (continued)

| Circuit<br>Ref<br>Symbol | Stock<br>No. | Description   | Mfr &<br>Mfrs<br>No. | Qty<br>In<br>Set | Qty<br>3 Mo.<br>Opn | Unit<br>Price |
|--------------------------|--------------|---|----------------------|------------------|---------------------|---------------|
| Y104                     |              | Crystal: quartz<br>500 kc, $\pm .01\%$<br>Pan Part Y-3013 | AT<br>Y-3013         | 1                |                     |               |
|                          |              | Head: attenuator, 20 db<br>Pan Part AF-1001               | AT<br>AF-1001        | 1                |                     |               |
|                          |              | Head: attenuator, 40 db<br>Pan Part AF-1002               | AT<br>AF-1002        | 1                |                     |               |
|                          |              | Head: attenuator, 60 db<br>Pan Part AF-1003               | AT<br>AF-1003        | 1                |                     |               |
|                          |              | Probe: tip, pointed<br>Pan Part E-2031                    | AT<br>E-2031         | 1                |                     |               |
|                          |              | Probe: tip, hooked<br>Pan Part E-2032                     | AT<br>E-2032         | 1                |                     |               |
|                          |              | Probe: tip, alligator<br>Pan Part E-2033                  | AT<br>E-2033         | 1                |                     |               |
|                          |              | Tool: alignment<br>Pan Part E-2022                        | AT<br>E-2022         | 1                |                     |               |
|                          |              | Tool: alignment<br>Pan Part E-2023                        | AT<br>E-2023         | 1                |                     |               |
|                          |              | Wrench: Bristol #6<br>Pan Part E-2013                     | AT<br>E-2013         | 1                |                     |               |
|                          |              | Wrench: Bristol #4<br>Pan Part E-2014                     | AT<br>E-2014         | 1                |                     |               |

List of Replaceable Parts for Power Supply, Model PS-19

| Circuit Ref Symbol | Stock No. | Description  | Mfr & Mfrs No.     | Qty In Set | Qty 3 Mo. Opn | Unit Price |
|--------------------|-----------|--|--------------------|------------|---------------|------------|
| C1                 |           | Capacitor: fixed, ceramic disc<br>.05 uf, 500 V<br>Pan Part CC-2123-1                          | AW<br>41C105       | 2          |               |            |
| C2                 |           | Capacitor: fixed, ceramic disc<br>.05 uf, 500 V<br>Pan Part CC-2123-1                          | AW<br>41C105       |            |               |            |
| C5                 |           | Capacitor: fixed, electrolytic<br>tubular, axial leads<br>80 uf, 450 V<br>Pan Part CE71X800R-1 | AW<br>TVA-<br>1716 | 2          |               |            |
| C7                 |           | Capacitor: fixed, electrolytic<br>tubular, axial leads<br>80 uf, 450 V<br>Pan Part CE71X800R-1 | AW<br>TVA-<br>1716 |            |               |            |
| C9                 |           | Capacitor: fixed, mylar<br>.1 uf, 400 V<br>Pan Part CT2126-5                                   | AP<br>338E104<br>M | 1          |               |            |
| C11                |           | Capacitor: fixed, paper, molded<br>tubular<br>.5 uf, 400 V<br>Pan Part CT-2061-10              | AV<br>330405       | 1          |               |            |
| C13                |           | Capacitor: fixed, electrolytic<br>twistlock<br>40 uf, 450 V<br>Pan Part CE31X400R-1            | AW<br>TVL-<br>1725 | 1          |               |            |
| C15                |           | Capacitor: fixed, electrolytic<br>tubular, axial leads<br>20 uf, 450 V<br>Pan Part CE71X200R-1 | AW<br>TVA-<br>1709 | 2          |               |            |

List of Replaceable Parts for Power Supply, Model PS-19 (continued)

| Circuit Ref Symbol | Stock No. | Description   | Mfr & Mfrs No.       | Qty In Set | Qty 3 Mo. Opn | Unit Price |
|--------------------|-----------|---|----------------------|------------|---------------|------------|
| C17                |           | Capacitor: fixed, electrolytic tubular, axial leads<br>20 uf, 450 V<br>Pan Part CE71X200R-1 | AW<br>TVA-1709       |            |               |            |
| C19<br>A, B        |           | Capacitor: fixed, paper dielectric<br>2 x 0.25 uf, 2000 V<br>Pan Part CP70D6XJ254X-5        | AP<br>7071           | 2          |               |            |
| C21<br>A, B        |           | Capacitor: fixed, paper dielectric<br>2 x 0.25 uf, 2000 V<br>Pan Part CP70D6XJ254X-5        | AP<br>7071           |            |               |            |
| CR1                |           | Rectifier: selenium, cartridge<br>5 ma, 1000 V<br>Pan Part CR-2008                          | AQ<br>V50HF          | 1          |               |            |
| CR3                |           | Rectifier: selenium, cartridge<br>5 ma, 2000 V<br>Pan Part CR-2005                          | AQ<br>V100HF         | 2          |               |            |
| CR5                |           | Rectifier: selenium, cartridge<br>5 ma, 2000 V<br>Pan Part CR-2005                          | AQ<br>V100HF         |            |               |            |
| F1                 |           | Fuse: instantaneous, glass cartridge<br>3 amp, 250 V<br>Pan Part F-2009                     | AT<br>F-2009         | 2          |               |            |
| F2                 |           | Fuse: instantaneous, glass cartridge<br>3 amp, 250 V<br>Pan Part F-2009                     | AT<br>F-2009         |            |               |            |
| J3                 |           | Connector: receptacle<br>5 pin, male contacts<br>Pan Part J-2013                            | AB<br>AN3102A-14S-5P | 1          |               |            |



List of Replaceable Parts for Power Supply, Model PS-19 (continued)

| Circuit Ref Symbol | Stock No. | Description   | Mfr & Mfrs No.          | Qty In Set | Qty 3 Mo. Opn | Unit Price |
|--------------------|-----------|---|-------------------------|------------|---------------|------------|
| J5                 |           | Jack: tip, black<br>Pan Part J-2001   | AD<br>407               | 1          |               |            |
| J7                 |           | Connector: receptacle<br>14 pin, female contacts<br>Pan Part J-2008                   | AB<br>AN3102<br>A-28-2S | 1          |               |            |
| R1                 |           | Resistor: fixed, composition<br>330,000 ohms, $\pm 10\%$ , 1 W<br>Pan Part RC32BX334K | AA<br>GB3341            | 2          |               |            |
| R3                 |           | Resistor: fixed, composition<br>330,000 ohms, $\pm 10\%$ , 1 W<br>Pan Part RC32BX334K | AA<br>GB3341            |            |               |            |
| R5                 |           | Resistor: fixed, composition<br>10 megohms, $\pm 5\%$ , 1/2 W<br>Pan Part RC20BX106J  | AA<br>EB1065            | 1          |               |            |
| R7                 |           | Resistor: fixed, composition<br>120 ohms, $\pm 5\%$ , 1/2 W<br>Pan Part RC20BX121J    | AA<br>EB1215            | 2          |               |            |
| R9                 |           | Resistor: fixed, composition<br>120 ohms, $\pm 5\%$ , 1/2 W<br>Pan Part RC20BX121J    | AA<br>EB1215            |            |               |            |
| R11                |           | Resistor: fixed, composition<br>1,000 ohms, $\pm 5\%$ , 1/2 W<br>Pan Part RC20BX102J  | AA<br>EB1025            | 2          |               |            |
| R13                |           | Resistor: fixed, composition<br>1,000 ohms, $\pm 5\%$ , 1/2 W<br>Pan Part RC20BX102J  | AA<br>EB1025            |            |               |            |
| R15                |           | Resistor: fixed, composition<br>8.2 megohms, $\pm 5\%$ , 1/2 W<br>Pan Part RC20BX825J | AA<br>EB8255            | 1          |               |            |

List of Replaceable Parts for Power Supply, Model PS-19 (continued)

| Circuit Ref Symbol | Stock No. | Description  | Mfr & Mfrs No. | Qty In Set | Qty 3 Mo. Opn | Unit Price |
|--------------------|-----------|--|----------------|------------|---------------|------------|
| R17                |           | Resistor: fixed, composition<br>3 megohms, $\pm 5\%$ , 1/2 W<br>Pan Part RC20BX305J    | AA<br>EB3055   | 4          |               |            |
| R19                |           | Resistor: fixed, composition<br>3 megohms, $\pm 5\%$ , 1/2 W<br>Pan Part RC20BX305J    | AA<br>EB3055   |            |               |            |
| R21                |           | Resistor: fixed, composition<br>240,000 ohms, $\pm 5\%$ , 1/2 W<br>Pan Part RC20BX244J | AA<br>EB2445   | 2          |               |            |
| R23                |           | Resistor: fixed, composition<br>3 megohms, $\pm 5\%$ , 1/2 W<br>Pan Part RC20BX305J    | AA<br>EB3055   |            |               |            |
| R25                |           | Resistor: fixed, composition<br>3 megohms, $\pm 5\%$ , 1/2 W<br>Pan Part RC20BX305J    | AA<br>EB3055   |            |               |            |
| R27                |           | Resistor: fixed, composition<br>100,000 ohms, $\pm 5\%$ , 1/2 W<br>Pan Part RC20BX104J | AA<br>EB1045   | 1          |               |            |
| R29                |           | Resistor: fixed, composition<br>1 megohm, $\pm 5\%$ , 1/2 W<br>Pan Part RC20BX105J     | AA<br>EB1055   | 2          |               |            |
| R31                |           | Resistor: fixed, composition<br>1 megohm, $\pm 5\%$ , 1/2 W<br>Pan Part RC20BX105J     | AA<br>EB1055   |            |               |            |
| R33                |           | Resistor: fixed, composition<br>240,000 ohms, $\pm 5\%$ , 1/2 W<br>Pan Part RC20BX244J | AA<br>EB2445   |            |               |            |
| R35                |           | Resistor: fixed, composition<br>68,000 ohms, $\pm 5\%$ , 1/2 W<br>Pan Part RC20BX683J  | AA<br>EB6835   | 1          |               |            |

List of Replaceable Parts for Power Supply, Model PS-19 (continued)

| Circuit Ref Symbol | Stock No. | Description  | Mfr & Mfrs No.         | Qty In Set | Qty 3 Mo. Opn | Unit Price |
|--------------------|-----------|--|------------------------|------------|---------------|------------|
| R37                |           | Resistor: fixed, composition<br>330,000 ohms, $\pm 5\%$ , 1/2 W<br>Pan Part RC20BX334J             | AA<br>EB3345           | 1          |               |            |
| R39                |           | Resistor: variable, composition<br>linear<br>50,000 ohms, $\pm 10\%$ , 2 W<br>Pan Part RVA503AQ-2J | AA<br>RV4NAY<br>SD503A | 1          |               |            |
| R41                |           | Resistor: fixed, composition<br>56,000 ohms, $\pm 5\%$ , 1/2 W<br>Pan Part RC20BX563J              | AA<br>EB5635           | 1          |               |            |
| R43                |           | Resistor: fixed, composition<br>100,000 ohms, $\pm 5\%$ , 1 W<br>Pan Part RC32BX104J               | AA<br>GB1045           | 3          |               |            |
| R45                |           | Resistor: fixed, composition<br>100 ohms, $\pm 5\%$ , 1 W<br>Pan Part RC32BX101J                   | AA<br>GB1015           | 1          |               |            |
| R47                |           | Resistor: fixed, composition<br>33,000 ohms, $\pm 5\%$ , 1 W<br>Pan Part RC32BX333J                | AA<br>GB3335           | 1          |               |            |
| R49                |           | Resistor: fixed, composition<br>30,000 ohms, $\pm 5\%$ , 1 W<br>Pan Part RC32BX303J                | AA<br>GB3035           | 1          |               |            |
| R51                |           | Resistor: fixed, composition<br>100,000 ohms, $\pm 5\%$ , 1 W<br>Pan Part RC32BX104J               | AA<br>GB1045           |            |               |            |
| R53                |           | Resistor: fixed, composition<br>10 megohms, $\pm 5\%$ , 2 W<br>Pan Part RC42BX106J                 | AA<br>HB1065           | 4          |               |            |
| R55                |           | Resistor: fixed, composition<br>10 megohms, $\pm 5\%$ , 2 W<br>Pan Part RC42BX106J                 | AA<br>HB1065           |            |               |            |

List of Replaceable Parts for Power Supply, Model PS-19 (continued)

| Circuit Ref Symbol | Stock No. | Description   | Mfr & Mfrs No.      | Qty In Set | Qty 3 Mo. Opn | Unit Price |
|--------------------|-----------|---|---------------------|------------|---------------|------------|
| R57                |           | Resistor: fixed, composition<br>100,000 ohms, $\pm 5\%$ , 1 W<br>Pan Part RC32BX104J  | AA<br>GB1045        |            |               |            |
| R59                |           | Resistor: fixed, composition<br>10 megohms, $\pm 5\%$ , 2 W<br>Pan Part RC42BX106J  | AA<br>HB1065        |            |               |            |
| R61                |           | Resistor: fixed, composition<br>10 megohms, $\pm 5\%$ , 2 W<br>Pan Part RC42BX106J  | AA<br>HB1065        |            |               |            |
| T1                 |           | Transformer: power, low voltage<br><u>Primary:</u> 115 V, 50 - 60 cps<br><u>Secondary:</u> 880 VCT, 200 ma dc;<br>5.0 V, 3.0 amp; 6.3 V, 3.0 amp;<br>6.3 V, 1.2 amp; 6.3 V, 6.0 amp<br>Pan Part T3-10791B | AT<br>T3-107<br>91B | 1          |               |            |
| T2                 |           | Transformer: power, high voltage<br><u>Primary:</u> 115 V/230 V, 50-60 cps<br><u>Secondary:</u> 1200 V, 4 ma; 6.4 V,<br>0.6 amp; 6.3 V, 6 amp<br>Pan Part T3-9875D  | AT<br>T3-9875<br>D  | 1          |               |            |
| V1                 |           | Electron Tube: 5U4<br>Pan Part 5U4  | BA<br>5U4           | 1          |               |            |
| V2                 |           | Electron Tube: 6146<br>Pan Part 6146  | BA<br>6146          | 2          |               |            |
| V3                 |           | Electron Tube: 6146<br>Pan Part 6146  | BA<br>6146          |            |               |            |
| V4                 |           | Electron Tube: 12AX7<br>Pan Part 12AX7  | BA<br>12AX7         | 2          |               |            |
| V5                 |           | Electron Tube: 12AX7<br>Pan Part 12AX7  | BA<br>12AX7         |            |               |            |

List of Replaceable Parts for Power Supply, Model PS-19 (continued)

| Circuit<br>Ref<br>Symbol | Stock<br>No. | Description                          | Mfr &<br>Mfrs<br>No. | Qty<br>In<br>Set | Qty<br>3 Mo.<br>Opn | Unit<br>Price |
|--------------------------|--------------|--------------------------------------|----------------------|------------------|---------------------|---------------|
| V6                       |              | Electron Tube: 5651<br>Pan Part 5651 | BA<br>5651           | 2                |                     |               |
| V7                       |              | Electron Tube: 5651<br>Pan Part 5651 | BA<br>5651           |                  |                     |               |

21188

MANUFACTURERS CODE FOR LIST OF REPLACEABLE PARTS

AA Allen-Bradley Company  
AB Amphenol Electronics Corporation  
AC Arrow-Hart & Hegeman Electric Company  
AD Birnbach Radio Company  
AE Cardwell Condenser Corporation  
AF Centralab Division of Globe-Union, Inc.  
AG Clarostat Manufacturing Company, Inc.  
AH Continental Carbon, Inc.  
AJ Cornell-Dubilier Electric Corporation  
AK E. F. Johnson Company  
AL Electro Motive Manufacturing Company  
AM Erie Resistor Corporation  
AN Stackpole Division, G-C Electronics Manufacturing Company  
AO General Electric Company  
AP Gudeman Manufacturing Company  
AQ International Resistance Company  
AR J. F. D. Electronics  
AS J. W. Miller Company  
AT Panoramic Radio Products, Inc.  
AU Radio Receptor, Inc.  
AV Sangamo Electric Company  
AW Sprague Electric Company  
AX Tele Radio Engineering Corporation  
AY Tru-Ohm Products Division, Model Engineering & Manufacturing, Inc.  
AZ Vari-L Corporation  
BA Any E. I. A. Manufacturer