

September 1956

PORTABLE TEST SET

AN/APM-3,3A

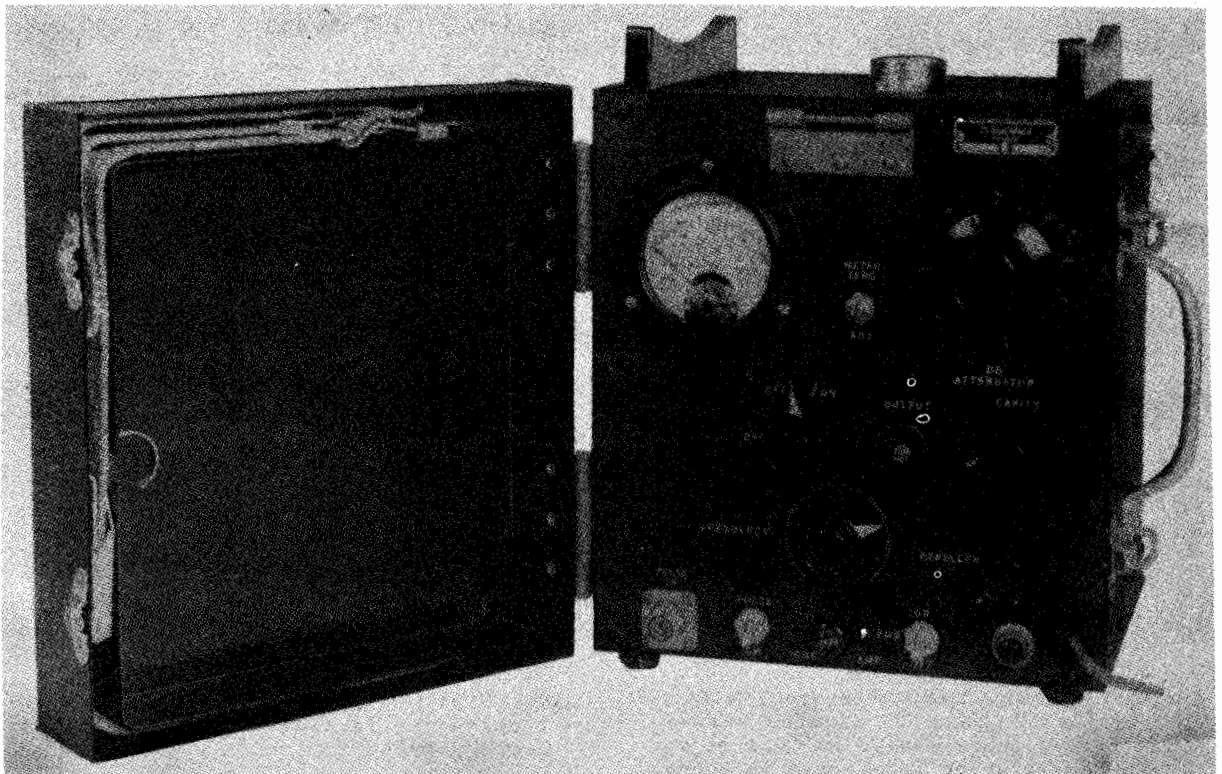

Radar Test Set, TS-45A/APM-3

FUNCTIONAL DESCRIPTION

The AN/APM-3, 3A are portable units used to measure radar transmitter frequency and relative power output. Can also be used as CW signal generator in receiver tests and as pulsed signal generator. The maximum RF power which can be safely applied to the test set is 5 watts.

No field changes in effect at time of preparation (17 May 1956).

RELATION TO OTHER EQUIPMENT

AN/SPM-3 and 3A are used in testing Radio Set AN/APS-4. The AN/SPM-3A is also used in testing ASD, AIA, AN/APS-1, 3, 6 and 15 Radar Equipments. The AN/SPM-3 may also be used to test these equipments when used with the proper adapters (not supplied).

Equipment Required but not Supplied: (3) Adapters UG-128/U, UG-129/U, and UG-130/U (AN/SPM-3 only); (1) Milliammeter TS-11/AP or equivalent; (1) Pulser (Measurements Corp) 79 B or equivalent.

ELECTRICAL AND MECHANICAL CHARACTERISTICS**FREQUENCY RANGE**

AN/APM-3: 9200 to 9600 mc.

AN/APM-3A: 9300 to 9450 mc.

POWER METER DATA**TEMPERATURE SENSITIVITY**

BRIDGE AND METER: Max deviation ± 0.4 mw from 0°F to 120°F .

ATTENUATOR: Max deviation ± 0.5 db from 0° to 120°F .

ACCURACY

ATTENUATOR: ± 1 db from 0 to 16 db; ± 2 db from 16 to 30 db.

OVERALL: ± 1.5 db for attenuator settings from 0 to 16 db; ± 2.5 db for attenuator settings from 16 to 32 db.

THERMAL DRIFT: Stabilizes after one minute warm up.

FREQUENCY SENSITIVITY

AN/APM-3: ± 0.5 mw (± 0.2 db) over range of 9200 to 9600 mc.

AN/APM-3A: ± 0.2 mw (± 0.1 db) over range of 9375 ± 75 mc.

UNCLASSIFIED

4.10 AN/APM-3: 1

AN/APM-3,3A

PORTABLE TEST SET

September 1956

FREQUENCY METER DATA

TYPE

AN/APM-3: 1/4 wavelength short-circuited coaxial line with loop coupling in line and probe coupling to waveguide. Q=900 approx.

AN/APM-3A: 3/4 wavelength short-circuited coaxial line with loop coupling in line and probe coupling to waveguide. Q=1500 approx.

RANGE CALIBRATION: Meters individually calibrated over range.

ACCURACY

AN/APM-3

ABSOLUTE: ±5 mc.

RESETTING: Measures relative frequencies within ±2 mc.

AN/APM-3A.

ABSOLUTE: ±2 mc.

RESETTING: measures relative frequencies within ±0.5 mc.

FREQUENCY STABILITY

AN/APM-3: Temperature coefficient is +0.1 mc / °F over frequency range.

AN/APM-3A: Temperature coefficient is -0.01 mc / °F over frequency range.

EFFECT ON OSCILLATOR (723A/B): Pulls oscillator -0.75 mc when tuned.

OSCILLATOR (723A/B)

FREQUENCY EQUILIBRIUM: Frequency drift of oscillator after 20 minutes warm-up at normal temperatures is -0.1 mc per min. Equilibrium is reached in approx one hours.

POWER OUTPUT

CW: 10 mw (nominal) for deflection of 100 on meter of test set.

PULSE MODULATED: 10 mw (peak) approx.

EXTERNAL PULSE GENERATOR

IMPEDANCE: 1000 ohm max.

DUTY CYCLE: 1% max.

PULSE VOLTAGE: Positive 150 v.

POWER REQUIREMENTS

AN/APM-3: 105 to 130 v, 60 to 800 cps, 45 W.

AN/APM-3A: 107 to 127 v 50 to 800 cps, 55 W; also it will operate satisfactorily at 1200 cps with a minimum of 113 v or 2400 cps with a minimum of 120 v.

MANUFACTURER'S OR CONTRACTOR'S DATA

Contract NXsa 32197

TUBE AND/OR CRYSTAL COMPLEMENT

(2) 6X5GT/G (2) VR105-30 (1) 723A/B

(1) 6V6GT/G (1) 6SL7GT

Total Tubes: (7)

(1) 1N21

Total Crystals: (1)

REFERENCE DATA AND LITERATURE

COAN08-30APM3-3: Technical Manual of Maintenance instructions for Portable Test Set AN/APM-3

COAN08-30AMP3-2: Technical Manual of Maintenance Instructions for Portable Test Set AN/APM-3A.

TYPE CLASSIFICATION
 DESIGN COGNIZANCE BUAER
 PROCUREMENT COGNIZANCE
 STOCK NO.
 R.D.B. IDENT. NO.

EQUIPMENT SUPPLIED DATA

QUANTITY PER EQUIPT	NAME AND NOMENCLATURE	OVERALL DIMENSIONS (inches)	WEIGHT (lbs.)
AN/APM 3 3A			
1	Radar Test Set TS-45/APM-3	7 X 8 X 11-1/4	
1	Auxiliary Test Kit and Test Meter TS-76/APM-3 consisting of:	7-1/16 X 7-13/16 X 10-1/4	
1	Horn AT-65/UP		
1	R-F Coupling UG-120/U		
1	R-F Coupling UG-121/U		
1	R-F Coupling UG-122/U		
1	Test Meter TS-75/U		
1	Plug and Cord Assembly CG-150/U		
1	Plug and Cord Assembly (operating spare)		
1	Crystal (operating spare)		
1	Attenuator Card (operating spare)		

PORTABLE TEST SET

AN/APM-3,3A

EQUIPMENT SUPPLIED DATA			
QUANTITY PER EQUIPT	NAME AND NOMENCLATURE	OVERALL DIMENSIONS (inches)	WEIGHT (lbs.)
AN/APM			
3			
3A			
1	Fuse (operating spare)		
1	Carrying Case		
1	Radar Test Set TS-45A/APM-3	8-1/2 X 10-3/4 X 11-1/4	
1	Auxiliary Test Kit and Test Meter TS-76A/APM-3	7-1/16 X 7-13/16 X 10-1/4	
	consisting of:		
1	Horn AT-65/UP		
1	R-F Coupling UG-120/U		
1	R-F Coupling UG-121/U		
1	R-F Coupling UG-122/U		
1	Test Meter TS-75A/U		
1	Plug and Cord Assembly CG-150/U		
1	Adapter UG-129/U		
1	Adapter UG-130/U		
1	Adapter UG-128/U		
1	Plug and Cord Assembly (operating spare)		
1	Crystal (operating spare)		
1	Attenuator Card (operating spare)		
1	Fuse (operating spare)		
1	Carrying case		

TEST SET INDICATOR

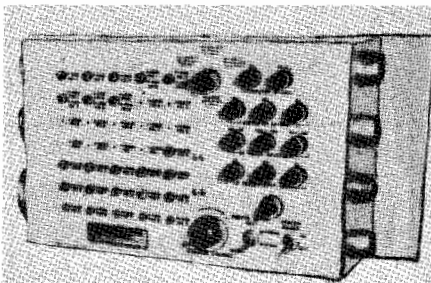

INTERCONNECTING BOX
J-577/APM-74

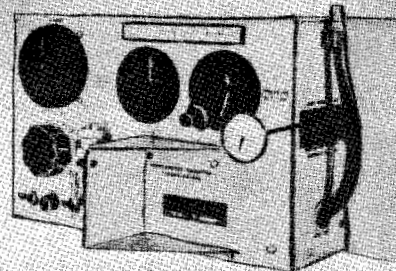

INDICATOR-SIMULATOR
ID-392/APM-74

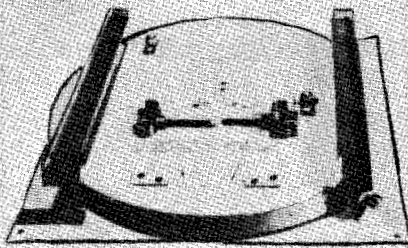

TEST STAND, ELECTRONIC EQUIPMENT
MT-1331/APM-74

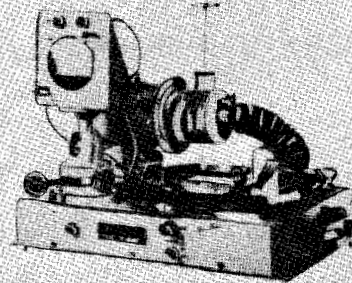

TEST STAND, CALIBRATION EQUIPMENT
MT-1332/APM-74

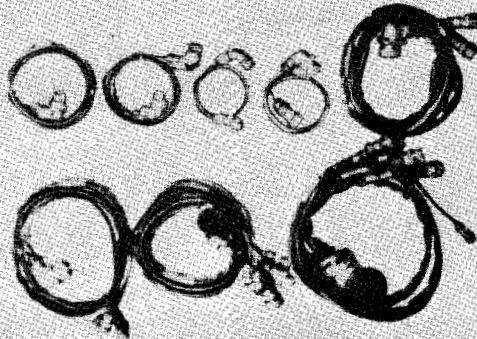

INTERCONNECTING CABLES
W-501 THROUGH W-508

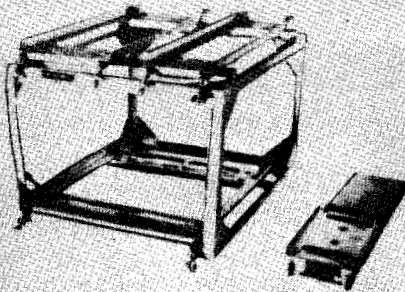

RACK, ELECTRICAL EQUIPMENT
MT-1333/APM-74

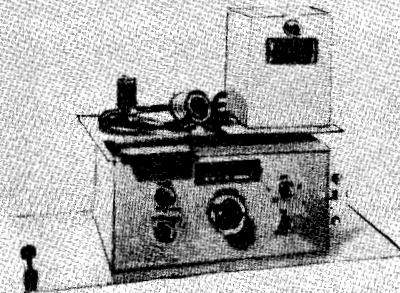

CALIBRATOR, INERTIA SWITCH
TS-801/APM-74

Indicator, Test Set AN/APM-74

Test-Combination and Group
AN/APM-74

TEST SET INDICATOR

FUNCTIONAL DESCRIPTION

The AN/APM-74 is a bench test harness assembly designed for maintaining and calibrating Ground Position Indicator AN/APA-57 Series. The equipment is installed on standard work benches and contains means of simulating the required signal inputs to the AN/APA-57 Series equipment.

The AN/APM-74 may be used to service any component of the following equipments: AN/APA-57, AN/APA-57A, AN/APA-57B and AN/APA-57C.

No field changes in effect at time of preparation (20 June 1957).

RELATION TO OTHER EQUIPMENT

Equipment Required but not Supplied: (1) Model "A" Work Bench, (1) Model "B" Work Bench (2) Shelf Assembly, (1) Nipple, (1) Elbow.

ELECTRICAL AND MECHANICAL CHARACTERISTICS

POWER SOURCE REQUIRED: 115 v, 400 cps, 3 ph Delta connected or 208 v, 400 cps, 3-ph, Y connected, 200 va; excitation voltages of ± 152 v.

TUBE AND/OR CRYSTAL COMPLEMENT

Tubes and Crystals: Not Available.

REFERENCE DATA AND LITERATURE

AN16-30APM74-3, Technical Manual for Test Set, Indicator AN/APM-74.

<p>TYPE CLASSIFICATION DESIGN COGNIZANCE BUAER PROCUREMENT COGNIZANCE STOCK NO. R.D.B. IDENT. NO.</p>

EQUIPMENT SUPPLIED DATA

QUANTITY PER EQUIPT	NAME AND NOMENCLATURE	OVERALL DIMENSIONS (inches)	WEIGHT (lbs.)
1	Indicator-Simulator ID-392/APM-74	8-1/2 x 9-1/2 x 18-3/4	11.25
1	Interconnecting Box J-577/APM-74	5-1/4 x 9-1/2 x 18-3/4	8.75
1	Test Stand, Electronic Equipment MT-1331/APM-74	3-1/2 x 17 x 17	11.50
1	Test Stand, Calibration Equipment MT-1332/APM-74	13-1/8 x 14 x 16-7/8	12.75
1	Rack, Electrical Equipment MT-1333/APM-74	16 x 17-5/8 x 24	11.00
1	Calibrator, Inertia Switch TS-801/APM-74	10-1/8 x 11 x 16-3/4	11.25
8	Interconnecting Cables		

1 June 1962

RADIO TEST SET AN/ARM-32

Cog Service: USN FSN:

Functional Class: 10.1

USA

USN

USAF

TYPE CLASS:

Used By

MANUFACTURER'S NAME/CODE NUMBER: Lear Inc., Lear Cal. Div., (89507).

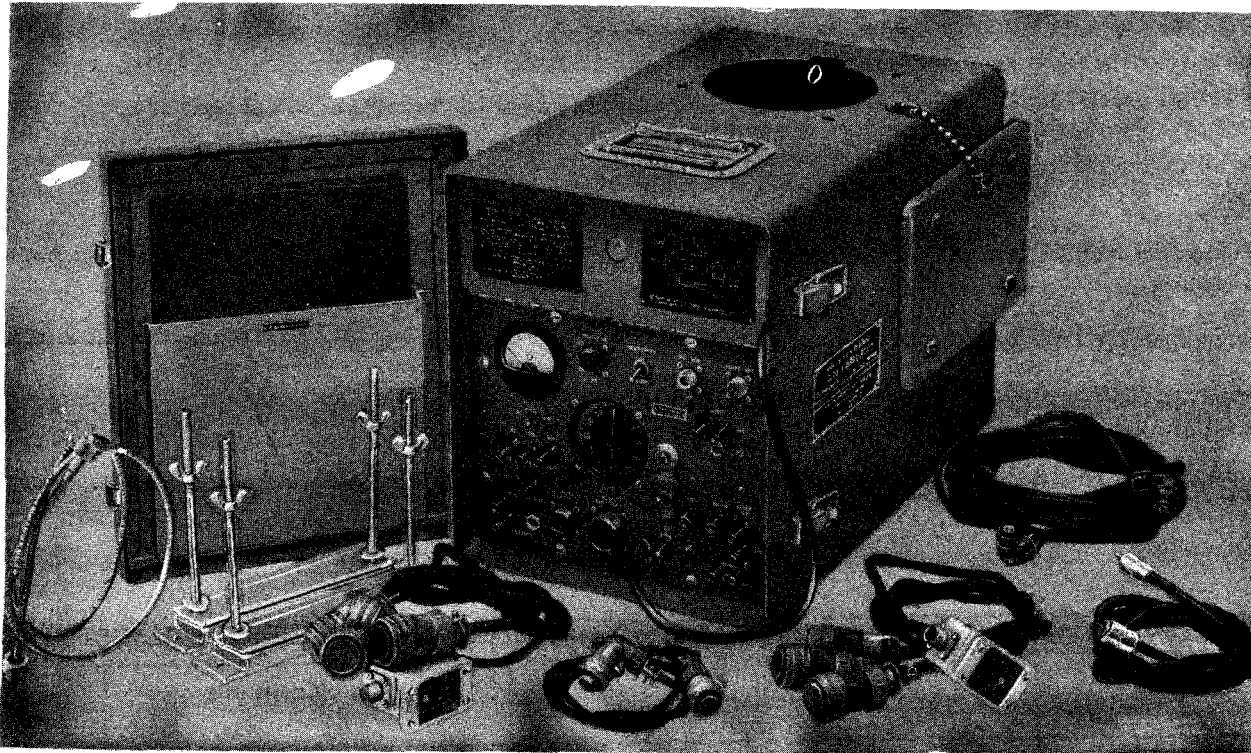

Radio Test Set AN/ARM-32

FUNCTIONAL DESCRIPTION:

Radio Test Set AN/ARM-32 serves as a junction box and a screen compartment to test and align Radio Receiving Sets AN/ARN-41, AN/ARN-41A, AN/ARN-41B, AN/ARN-54 and AN/ARN-59. The test set allows over-all equipment sensitivity measurements to be made for both the communications receiver and automatic direction finder functions of the receiving sets. In addition, the test set facilitates certain other tests for trouble shooting purposes.

No field changes in effect at time of preparation (18 September 1961).

TECHNICAL CHARACTERISTICS:

POWER REQUIREMENTS: 22 to 30 v dc, 5 amps.

AN/ARM-32 RADIO TEST SET

RELATION TO OTHER EQUIPMENT: None.

EQUIPMENT REQUIRED BUT NOT SUPPLIED:

(1) Radio Receiving Set AN/ARN-41, AN/ARN-41A, AN/ARN-41B, AN/ARN-54, or AN/ARN-59.

MAJOR COMPONENTS

QTY	ITEM	STOCK NUMBERS	DIMENSIONS (INCHES)	WEIGHT (LBS).
1	Radio Test Set AN/ARM-32 includes:		12 x 14 x 20	
1	Test Set, Radio TS-1062/ARM-32			
1	Cover, Test Set CW-440/ARM-32			
1	Cable Assy, Special Purpose, Electrical, Branched CX-4140/ARM-32			
1	Cable Assy, Special Purpose, Electrical, Branched CX-4141/ARM-32			
1	Cable Assy, Special Purpose, Electrical CX-4142/ARM-32			
1	RG-114/U Cable Assy, R.F. CG-1569/U		73-1/2 lg	
1	Cable Assy, R.F. CG-1568/ARM-32			
1	Shaft Assy, Flexible MX-2257/ARM-32			
1	Mounting MT-1890/ARM-32			
1	Test Accessory Kit for Radio Re- ceiving Set AN/ARN-59 consists of:			
1	Cable Assy, Special Purpose, Electrical, Branched CX-4571/ARM-32			
1	Cable Assy, Special Purpose, Electrical CX-4572/U		60 lg	
1	Cable Assy, Special Purpose, Electrical CX-4232/ARM-59			
1	Tuning Adapter ARC Part no. 18802			

REFERENCE DATA AND LITERATURE:

NAVWEPS 16-45-619: Operation and Service Instructions with Illustrated Parts Breakdown for Radio Test Set AN/ARM-32.

TUBE, CRYSTAL AND/OR SEMI-CONDUCTOR DATA:

TUBES: None used.

CRYSTALS: None used.

SEMI-CONDUCTORS: None used.

SHIPPING DATA

PKGS	VOLUME (CU FT)	WEIGHT (LBS)
------	----------------	--------------

PROCUREMENT DATA

PROCURING SERVICE: USN	DESIGN COG: USN, BuWeps
SPEC &/OR DWG: MIL-H-15362A	

CONTRACTOR	LOCATION	CONTRACT OR ORDER NO.	APPROX. UNIT COST
Lear Inc., Lear Cal. Div.	Santa Monica, California	N0as-56-879	

TELEMETRIC DATA TEST SET

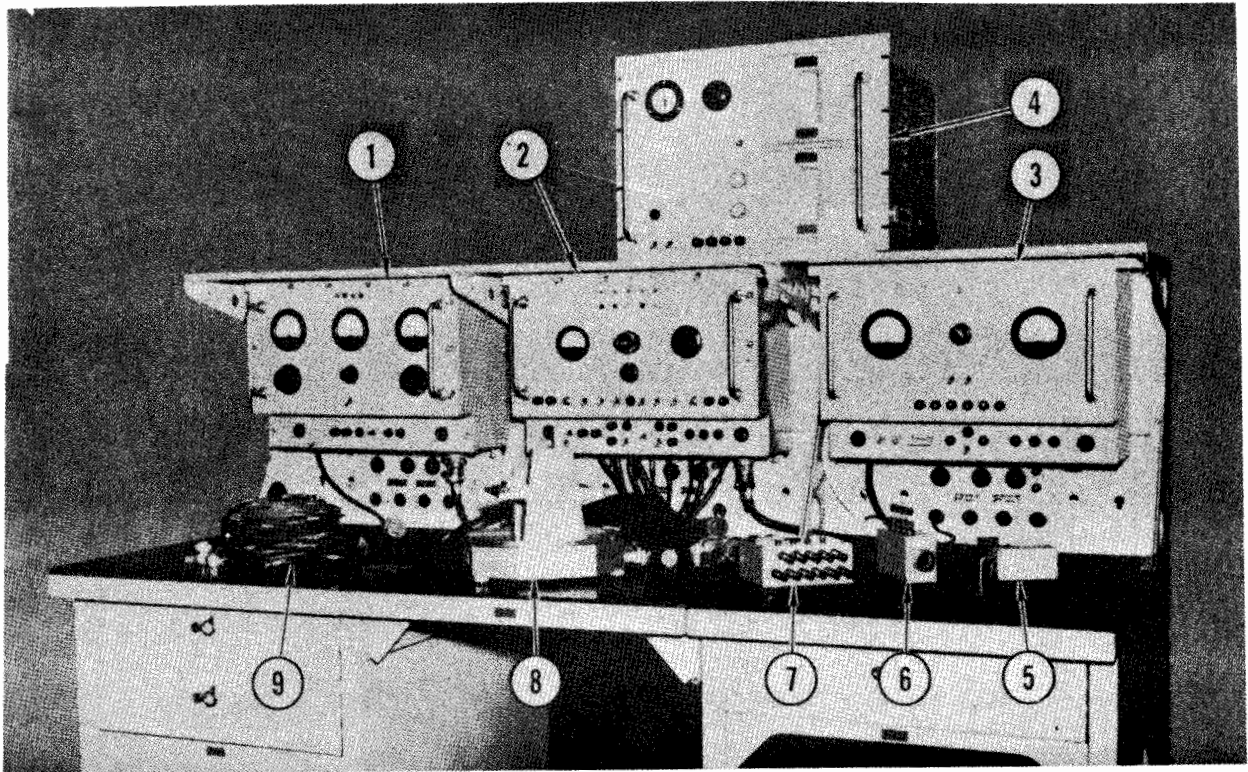

1. Dynamotor Test Set TS-993/DKM-1
2. Calibrator Test Set TS-994/DKM-1
3. Power Supply PP-1613/DKM-1
4. Airspeed and Height Simulator SM-99/DKM-1
5. Adapter Oscillator MX-2091/DKM-1
6. Interconnecting Box J-786/DKM-1
7. Interconnecting Box J-787/DKM-1
8. Gyro Test Stand MT-1755/DKM-1
9. Adapter Cable Assembly CVE-089998

Telemetric Data Test Set AN/DKM-1

FUNCTIONAL DESCRIPTION

The AN/DKM-1 is designed to bench test and facilitate maintenance of the airborne components of the Out-Of-Sight Control Instrumentation (OOSCI) system installed in Regulus KDU-1 Target Drones.

No field changes in effect at time of preparation (6 May 1957).

RELATION TO OTHER EQUIPMENT

Equipment Required but not Supplied: (1) Vacuum Tube Voltmeter ME-6B/U, (1) Vacuum Tube Voltmeter TS-375A/U, (1) Multimeter AN/PSM-4, (1) Oscilloscope, (1) Audio Oscillator TS-382D/U, (1) Audio Oscillator TS-421A/U, (1) RF Wattmeter AN/URM-43, (1) R.F. Frequency Meter TS-173/UR, (1) Power Supply PP-

79/UR, (1) RF Signal Generator TS-608/U, (1) Frequency Meter FR-38/USM-26, (1) Load Bank 0 to 10 ma at 105 v DC, (1) Load Bank 0 to 10 ma at 150 v DC, (1) Potentiometer 5 k, 2 w, (1) Mercury manometer and fittings 1.5 to 30 psia and (1) Spirit Level.

ELECTRICAL AND MECHANICAL CHARACTERISTICS

POWER SOURCE REQUIRED: 115 v, 400 cps, 115 v, 60 cps or 28 v DC.

SIMULATOR SIGNAL VOLTAGE OUTPUTS

GYRO SIGNAL: 0 to 10 v rms.

CVCV-47 TEST: 0 to 5 v DC.

BATTERY LOAD: 33 ohm load resistor simulator.

VARIABLE LOAD BANK CIRCUITS: 212 v DC, 255 v DC and 500 v DC.

AIRSPEED: To 10.5 psig.

HEIGHT: 2 psia.

Test-Combination and Group

AN/DKM-1

TELEMETRIC DATA TEST SET

MANUFACTURER'S OR CONTRACTOR'S DATA

Cook Electric Co., Chicago, Ill.
Contract NOas-53-886.

REFERENCE DATA AND LITERATURE

NAVAER 16-30DKM-501, Technical Manual for
Telemetric Data Test Set AN/DKM-1.

TUBE AND/OR CRYSTAL COMPLEMENT

(2) OB2WA (1) 5R4WGA
(1) 6080WA (1) 5751
Total Tubes: (5)

TYPE CLASSIFICATION
DESIGN COGNIZANCE BUAER
PROCUREMENT COGNIZANCE MIL-T-9454 Amend 1
STOCK NO.
R.D.B. IDENT. NO.

EQUIPMENT SUPPLIED DATA

QUANTITY PER EQUIPT	NAME AND NOMENCLATURE	OVERALL DIMENSIONS (inches)	WEIGHT (lbs.)
1	Power Supply PP-1613/DKM-1		
1	Calibrator Test Set TS-994/DKM-1		
1	Test Set Dynamotor TS-993/DKM-1		
1	Simulator Air Speed and Height SM-99/DKM-1		
1	Interconnecting Box J-787/DKM-1		
6	Adapter, Oscillator MX-2091/DKM-1		
1	Gyro Test Stand MT-1755/DKM-1		
1	Interconnecting Box J-786/DKM-1		
1	Cable Adapter-089998		

UNCLASSIFIED

March 1957

Test-Combination and Group

MULTIMETER

AN/FSM-6

FUNCTIONAL DESCRIPTION

The AN/FSM-6 is a portable combination electronic AC voltmeter for measurement of peak-to-peak and RMS voltages, DC voltmeter, ohmmeter and milliammeter which can be used wherever it is necessary to make current resistance and voltage measurements with the use of only one equipment.

No field changes in effect at time of preparation (10 Oct 1956).

RELATION TO OTHER EQUIPMENT

Electrically and functionally identical to but not mechanically interchangeable with Multimeter AN/USM-34.

ELECTRICAL AND MECHANICAL CHARACTERISTICS

AC VOLTS: (Measured and Calibrated in Peak-to-Peak)

RANGE: 3 ranges, 0 to 3000 v.

INPUT IMPEDANCE: 14 meg.

ACCURACY: ±6% up to 100 v; ±7% over 100 v.

RF VOLTS: (Measured on Peak Value of Voltage Being Measured and Calibrated as RMS Value).

RANGE: 2 ranges, 0 to 100 v with RF probe and cable assy.

INPUT IMPEDANCE: 13 meg.

ACCURACY: ±6% up to 100 v.

DC VOLTS

RANGE: 4 ranges, 0 to 1000 v.

INPUT IMPEDANCE: 13.3 meg.

ACCURACY: ±4% up to 1000 v; ±7% over 1000 v (with probe extension).

RESISTANCE

RANGE: 4 ranges, 0 to 2000 meg.

ACCURACY: ±5 deg of arc.

MILLIAMPERES, DC

RANGE: 4 ranges, 0 to 1000 ma.

ACCURACY: ±5%.

POWER SOURCE: 105 to 125 v, 50 to 1000 cps, single ph.

MANUFACTURER'S OR CONTRACTOR'S DATA

Hickok Electrical Instrument Co, Cleveland, Ohio

TUBE AND/OR CRYSTAL COMPLEMENT

No Electron Tubes.

REFERENCE DATA AND LITERATURE

Nomenclature Card for Multimeter AN/FSM-6.

TYPE CLASSIFICATION
DESIGN COGNIZANCE BUSHIPS
PROCUREMENT COGNIZANCE
STOCK NO.
R.D.B. IDENT. NO.

EQUIPMENT SUPPLIED DATA

QUANTITY PER EQUIPT	NAME AND NOMENCLATURE	OVERALL DIMENSIONS (inches)	WEIGHT (lbs.)
1	Multimeter AN/FSM-6	5-3/8 X 8-11/16 X 11-18	
1	DC Multiplier Extension, High Voltage		
2	Technical Manual		
1	Chart		

UNCLASSIFIED

12 February 1963
Cog Service: USN

FSN:

MULTIMETER AN/FSM-6A

Functional Class: 10

USA

USN

USAF

TYPE CLASS:

Used by

MANUFACTURER'S NAME/CODE NUMBER: Rudnose Associates Inc., (12435).

(No Illustration Available)

FUNCTIONAL DESCRIPTION:

Multimeter AN/FSM-6A is for general purpose use and is enclosed in a metal case, enameled finished; it does not include a carrying case.

No field changes in effect at time of preparation (23 September 1960).

TECHNICAL CHARACTERISTICS:

TYPE OF METER: Electronic type.

RANGE AND QUANTITY OF STEPS: 0 to 1000 v dc in 4 steps, 3000 v dc with extension probe, 0 to 1000 v ac in 4 steps, 0 to 1 amp dc in 4 steps, 0 to 100 v rf in 3 steps, 0 to 2000 meg in 4 steps.

FREQUENCY RANGE: 1 kc to 100 mc.

INPUT IMPEDANCE: DC 13.3 meg on 0 to 1, 10, 100, 1000 v range; 38.3 meg with HV multiplier test prod.

OPERATING POWER RQMT: 105/125 v ac, 50 to 1000 cps, single ph.

RELATION TO OTHER EQUIPMENT:

The AN/FSM-6A is interchangeable with Multimeter AN/FSM-6 different parts due to different manufacturer.

EQUIPMENT REQUIRED BUT NOT SUPPLIED: None.

MAJOR COMPONENTS

QTY	ITEM	STOCK NUMBERS	DIMENSIONS (INCHES)	WEIGHT (LBS)
1	Multimeter AN/FSM-6A consists of:			
1	Multimeter ME-154/FSM-6A includes:			
2	Technical Manual			
1	Power Cable			
1	RF Probe			
1	Low Frequency AC Test Leads			
1	Isolating Probe for DC Measurements			

AN/FSM-6A MULTIMETER

QTY	ITEM	STOCK NUMBERS	DIMENSIONS (INCHES)	WEIGHT (LBS)
1	Voltage DC Multiplier Extension			
2	Test Prod w/4ft Leads, one red and one black			

REFERENCE DATA AND LITERATURE:

TUBE, CRYSTAL AND/OR SEMI-CONDUCTOR DATA:

TUBES: (1) 5726-6AL5W (1) 5751 (1) 5814A (1) 9006

CRYSTALS: None used.

SEMI-CONDUCTORS: (1) 1N69

SHIPPING DATA

PKGS	VOLUME (CU FT)	WEIGHT (LBS)
------	----------------	--------------

PROCUREMENT DATA

PROCURING SERVICE: USN

DESIGN COG: USN, BuShips

SPEC &/OR DWG: MIL-M-19717(SHIPS)

CONTRACTOR	LOCATION	CONTRACT OR ORDER NO.	APPROX. UNIT COST
Rudnose Associates Inc.	Richmond, Texas	N0bsr 71872, 12 December 1958	

August 1957

Test-Combination and Group

TEST SET

AN/GRM-1A

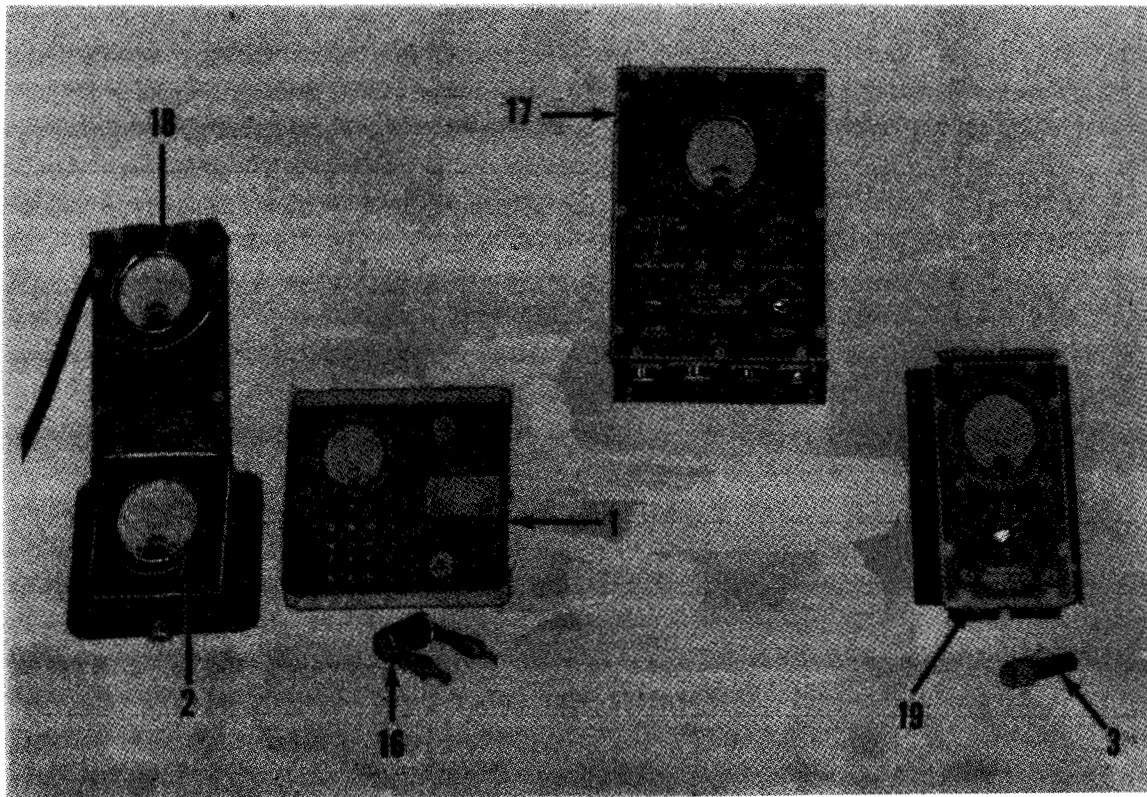

Test Set AN/GRM-1A

FUNCTIONAL DESCRIPTION

The AN/GRM-1A is for general ground use in the bench testing of airborne radio receiving and transmitting equipments. In addition to the test equipment components miscellaneous tools are provided.

No field changes in effect at time of preparation (11 January 1957).

RELATION TO OTHER EQUIPMENT

Equipment Required but not Supplied: (1) headset extension cord, (1) Microphone and (1) 600 ohm headset.

TUBE AND/OR CRYSTAL COMPLEMENT

No Electron Tubes.

REFERENCE DATA AND LITERATURE

NAVAER 08-5S-78: Technical Manual of Test Equipment for Airborne Electrical and Electronic Equipment.

TYPE CLASSIFICATION DESIGN COGNIZANCE BUAER PROCUREMENT COGNIZANCE STOCK NO. R.D.B. IDENT. NO.

METER TEST EQUIPMENT

AN/GSM-1



Meter Test Equipment AN/GSM-1

FUNCTIONAL DESCRIPTION

The AN/GSM-1 is designed to provide a means for testing and calibrating meters, except wattmeters used as electronic measuring devices at repair depots ashore or afloat. The equipment is portable and self-contained and may be carried in a repair truck.

The equipment is applied to furnish a source of either DC or AC voltage, which is variable over a range from zero to 1500 v used to test the operation and accuracy of voltmeters, to furnish DC current, variable over a range from zero to 75 amperes and AC current, variable over a range from zero to 10 amperes used to test the action and accuracy of microammeters, milliammeters and ammeters, provide a voltmeter standards unit to check the accuracy of AC or DC voltmeters, provide an ammeter standards unit to check the accuracy of AC or DC current measuring

instruments, provides a wheatstone bridge for making precise resistance measurements, provides a test set for making resistance and voltage measurements and to check vacuum tubes used in electrical circuits of test instruments with meter type indicators, provides a decade resistance box to furnish accurately known resistance values when testing meter circuits. The equipment also provides a magnet charger to remagnetize meter magnets which have lost a part of the strength of their magnetic fields and a demagnetizer to reduce the field strength of meter magnets which have been magnetized too strongly. A Frequency meter used as a standard in calibrating and testing the performance of power frequency meters between the limits of 50 and 70 cycles per second and meter calibration panels are supplied.

No field changes in effect at time of preparation (4 February 1957).

October 1957

Test-Combination and Group

AN/GSM-1

METER TEST EQUIPMENT

ELECTRICAL AND MECHANICAL CHARACTERISTICS

VOLTAGE SUPPLY UNIT PP-14/GSM-1.

INPUT: 100 to 120 v, 60 cps, regulated.

INPUT TRANSFORMER: Multicap primary.

OUTPUT: Variable AC or DC.

OUTPUT RANGES: DC, 0 to 1.5 v, 0 to 7.5 v, 0 to 15 v, 0 to 75 v, 0 to 150 v, 0 to 750 v, 0 to 1500 v; AC, 0 to 3 v, 0 to 6 v, 0 to 15 v, 0 to 30 v, 0 to 75 v, 0 to 750 v, 0 to 1500 v.

ACCURACY: $\pm 1\%$.

AC RIPPLE: Less than 5%.

OUTPUT AVAILABLE: 500 v-amp.

CURRENT SUPPLY UNIT PP-15/GSM-1.

INPUT: 6 v DC from battery capable of delivering 75 amp for short period or, 6 v DC from rectifier unit with AC ripple less than 5%; AC, 100 to 120 v, 60 cps, regulated.

OUTPUT: Variable AC or DC.

OUTPUT RANGES: DC, 0 to 150 ua, 0 to 750 ua, 0 to 1.5 ma, 0 to 7.5 ma, 0 to 15 ma, 0 to 75 ma, 0 to 150 ma, 0 to 750 ma, 0 to 1.5 amp, 0 to 7.5 amp, 0 to 15 amp, 0 to 75 amp; AC, 0 to 150 ma, 0 to 750 ma, 0 to 1000 ma, 0 to 5 amp, 0 to 10 amp.

AC OUTPUT AVAILABLE: 70 v-amp.

VOLTMETER STANDARDS UNIT TS-49/GSM-1.

ACCURACY: $\pm 1\%$.

AMMETER STANDARDS UNIT TS-50/GSM-1.

ACCURACY: $\pm 1\%$.

MOUNTING MT-135/GSM-1.

LEAKAGE CURRENT: Not over 2 ua at 1500 v.

MOUNTING MT-175/GSM-1.

DROP DUE TO CONTACT RESISTANCE: 0.02 v approx at 1.5 amp.

DECADE RESISTANCE BOX:

RANGE: 111,110 ohms in 1 ohm steps.

DECADES: 5.

CONTACTS PER DECADE: 11.

ZERO RESISTANCE: 0.010 to 0.015 ohm.

TEMPERATURE COEFFICIENT: $\pm 0.002\%$ per deg

C at room temperature.

MAGNET CHARGER TS-336/GSM-1.

INPUT VOLTAGE: 105 to 125 v, 60 cps.

PEAK INPUT CURRENT: 10 amp rms.

AVERAGE INPUT CURRENT: 2 amp rms.

CAPACITOR CHARGING TIME: 10 sec.

PEAK DISCHARGE VOLTAGE: 2.15 v.

PEAK DISCHARGE CURRENT

7 SWITCH BLADES: 50,000 amp.

6 SWITCH BLADES: 47,000 amp.

5 SWITCH BLADES: 44,000 amp.

3 SWITCH BLADES: 38,000 amp.

2 SWITCH BLADES: 35,000 amp.

DISCHARGE FREQUENCY: 40 to 80 cycles/sec for 1/2 switching cycle.

DEMAGNETIZING COIL

INPUT VOLTAGE: 110 v, 60 cps.

INPUT CURRENT: 3.5 amp.

MAX DEMAGNETIZING FIELD: 300 oersteds steady state.

TEMPERATURE RISE: 100° C after 10 minutes continuous duty.

FREQUENCY METER.

INPUT: 115 v, 50 to 60 cps.

RANGE: 50 to 60 cps.

ACCURACY: $\pm 0.5\%$.

SCALE: 5-1/4 in.

TUBE AND/OR CRYSTAL COMPLEMENT

(3) 866A/866

(1) WL-677

Total Tubes: (4)

REFERENCE DATA AND LITERATURE

TM11-2535, Technical Manual for Meter Test Equipment AN/GSM-1.

TYPE CLASSIFICATION
DESIGN COGNIZANCE TASSA
PROCUREMENT COGNIZANCE
STOCK NO.
R.D.B. IDENT. NO.

EQUIPMENT SUPPLIED DATA

QUANTITY PER EQUIPT	NAME AND NOMENCLATURE	OVERALL DIMENSIONS (inches)	WEIGHT (lbs.)
1	Voltage Supply Unit PP-14/GSM-1	10 X 10 X 21	60
1	Current Supply Unit PP-15/GSM-1	8 X 10 X 16	30
1	Voltmeter Standards Unit TS-49/GSM-1	8 X 14-1/2 X 16	25
1	Ammeter Standards Unit TS-50/GSM-1	10 X 16-1/2 X 20	40
1	Case CY-25/GSM-1	18 X 20 X 22	35
1	Case CY-24/GSM-1	14 X 27 X 28	35
1	Mounting MT-135/GSM-1	6-1/2 X 7-1/2 X 7-1/2	2
1	Mounting MT-175/GSM-1	6-1/2 X 7-1/2 X 7-1/2	2

UNCLASSIFIED

October 1957

Test-Combination and Group

METER TEST EQUIPMENT

AN/GSM-1

EQUIPMENT SUPPLIED DATA

QUANTITY PER EQUIPT	NAME AND NOMENCLATURE	OVERALL DIMENSIONS (inches)	WEIGHT (lbs.)
1	Test Set I-49	5-3/4 X 7-3/8 X 8-7/8	8
1	Test Set I-56-K	9-3/4 X 14-3/4 X 20-1/2	55
1	Cord CX-25-A/GSM-1	3/8 dia X 72 lg	
1	Cord CX-25-B/GSM-1	3/8 dia X 72 lg	
2	Cord CD-370	0.341 dia X 72 lg	
1	Decade Resistance Box (DAVEN 750-K)	5 X 5 X 15-5/8	6.25
1	Decade Resistance Box (DAVEN 750-2)	5 X 5 X 15-5/8	6.25
1	Magnet Charger TS-336/GSM-1 Demagnetizer	14 X 17-5/8 X 27-1/4 2-1/16 X 3-3/8 IDX 14 X 7-5/8 OD	250 8
1	Frequency Meter (Weston 339)	8-3/16 X 8-1/4 X 10-7/16	23
1 set	Meter Calibration Panels (10 steel rings)		

UNCLASSIFIED

4.10 AN/GSM-1: 3

UNCLASSIFIED

October 1957

Test-Combination and Group

TEST BENCH GROUP, BOMBING NAVIGATIONAL SYSTEM

AN/GWM-5

FUNCTIONAL DESCRIPTION

The AN/GWM-5 is used to provide a quick means of ground testing all components of the Bombing Navigational System, Optical and Radar type MA-6A and MA-7A.

No field changes in effect at time of preparation (8 May 1957).

RELATION TO OTHER EQUIPMENT

Similar to but not interchangeable w/Test Bench Group, Bombing Navigational System, Type MC-1.

ELECTRICAL AND MECHANICAL CHARACTERISTICS

POWER SOURCE REQUIRED: 27 v DC, 115 v, 60 cps, single ph, 115 v, 400 cps, regulated single ph, 115 v, 400 cps, regulated, three ph.

MANUFACTURER'S OR CONTRACTOR'S DATA

Amphenol Electronics Corp., Cicero, Illinois.

TUBE AND/OR CRYSTAL COMPLEMENT

Tubes and Crystals: Not Available.

REFERENCE DATA AND LITERATURE

Nomenclature Card for Test Bench Group, Bombing Navigational System AN/GWM-5 dated 27 September 1956.

TYPE CLASSIFICATION
DESIGN COGNIZANCE BUSHIPS
PROCUREMENT COGNIZANCE
STOCK NO.
R.D.B. IDENT. NO.

EQUIPMENT SUPPLIED DATA

QUANTITY PER EQUIPT	NAME AND NOMENCLATURE	OVERALL DIMENSIONS (inches)	WEIGHT (lbs.)
1	Track and Bomb Computer Bench		
1	Polar Converter and Computer Amplifier Bench		
1	Control and Power Distribution Bench		
1	Heading and Interconnecting Equipments Components Bench		
1	Stabilization Components Bench		
1	Periscope Stand		
1	Radar Bench #1 and Cover		
1	Radar Bench #2 and Cover		
1	Utility Box		

UNCLASSIFIED

4.10 AN/GWM-5: 1

September 1956

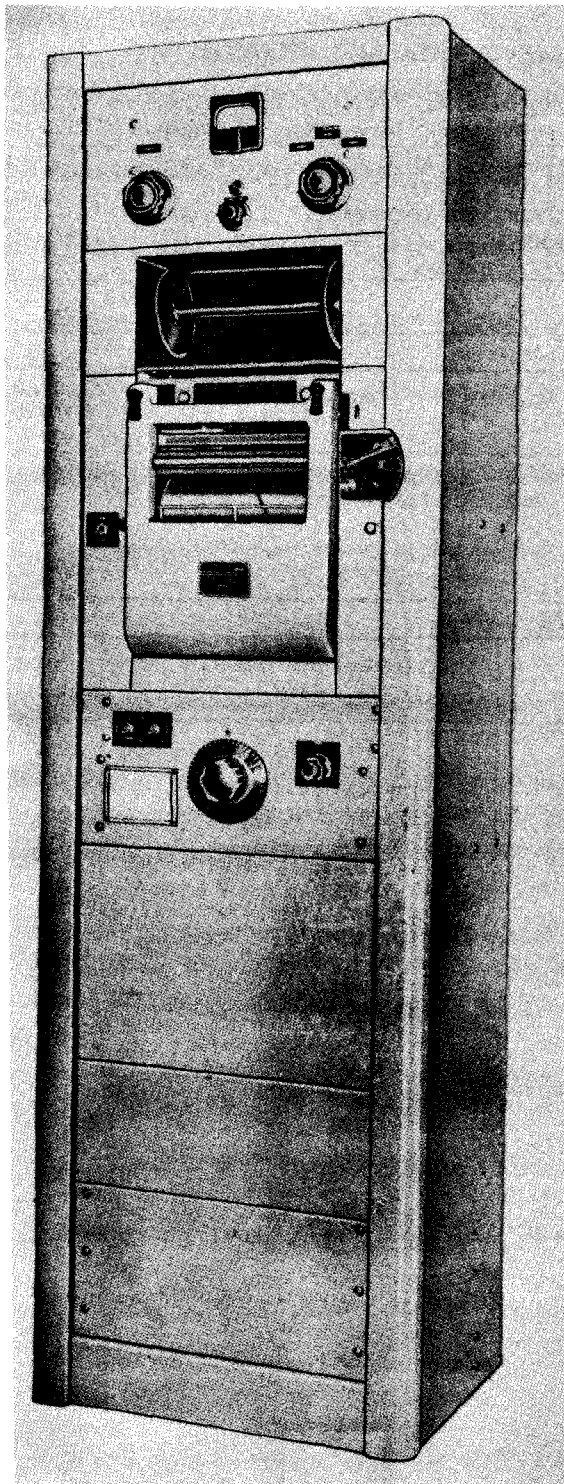
FREQUENCY TIME RECORDING SET**AN/GXH-1***Frequency Time Recording Set AN/GXH-1***FUNCTIONAL DESCRIPTION**

The AN/GXH-1 is used to graphically record electrical signals or groups of a definite cyclic or repetitive nature. An immediate visible permanent record is made on a continuous strip which may be observed at the instant of recording or accumulated for subsequent visual analysis. It is designed to operate at normal room temperatures in a fixed field station.

No field change in effect at time of preparation (19 June 1956).

ELECTRICAL AND MECHANICAL CHARACTERISTICS**RECORDING SIGNAL SET**

FREQUENCY RANGE: 30 to 15000 cps.

POWER REQUIREMENTS: 105 to 130 v, single ph, 50 to 60 cps, 715 W.

RECORDER AMPLIFIER

FREQUENCY RANGE: 30 to 15000 cps.

INPUT IMPEDANCE: 500 ohms.

MARKING CURRENT: 275 ma.

POWER REQUIREMENTS: 105 to 130 v, single ph, 50 to 60 cps, 160 W.

OSCILLATOR

FREQUENCY, VARIABLE: 45 to 100 cps.

DESIGN LOAD: 250000 ohms.

VOLTAGE OUTPUT, OPEN CIRCUIT: 3.5 v rms.

POWER REQUIREMENTS: 105 to 130 v, single ph, 50 to 60 cps, 35 W.

ELECTRONIC CONTROL

FREQUENCY, VARIABLE: 45 to 100 cps.

POWER OUTPUT: 75 voltamps.

INPUT IMPEDANCE: 250000 ohms.

OUTPUT IMPEDANCE: 200 ohms.

POWER REQUIREMENTS: 105 to 130 v, single ph, 50 to 60 cps, 300 W.

RECORDER

DRUM SPEED: 45 to 400 rpm.

PAPER FEED RATE: 8 to 125 lines per in.

SYNCHRONOUS MOTOR SPEED: 3600 rpm.

SYNCHRONOUS MOTOR HORSEPOWER: 1/50.

MANUFACTURER'S OR CONTRACTOR'S DATA

Hogan Laboratories, Inc., New York, N.Y.

Contract: NObsr-52684, dated 30 June 1951

Approximate cost: \$9850.00

TUBE AND/OR CRYSTAL COMPLEMENT

- (1) OC3
- (1) OD3
- (4) 6AS7G
- (2) 6H6
- (1) 5Y3GT
- (2) 6L6G
- (1) 6SJ7
- (4) 6SN7GT
- (6) 83

Total Tubes: (22)

REFERENCE DATA AND LITERATURE

NAVSHIPS 91742: Technical Manual for frequency Time Recording Set AN/GXH-1.

TYPE CLASSIFICATION
DESIGN COGNIZANCE BUSHIPS
PROCUREMENT COGNIZANCE
STOCK NO.
R.D.B. IDENT. NO.

SHIPPING DATA

NUMBER OF BOXES	CONTENTS AND IDENTIFICATION	VOLUME (Cu.Ft.)	OVERALL DIMENSIONS (inches)	WEIGHT PACKED (lbs.)
1	Recording Set, Frequency, Time AN/GXH-1*	28	24 x 28 x 82-1/8	450
1	Recorder Paper	8.2	12 x 18 x 18	75

* Spare parts are in three (3) separate boxes

EQUIPMENT SUPPLIED DATA

QUANTITY PER EQUIPT	NAME AND NOMENCLATURE	OVERALL DIMENSIONS (inches)	WEIGHT (lbs.)
1	Amplifier, Electronic Cont. AM-779/GXH-1	8-3/4 x 14 x 19	67
1	Control Panel SB-264/GXH-1	3 x 19 x 19-9/32	8
1	Oscillator, AF 0-181/GXH-1	6 x 8-3/4 x 19	25
1	Power Panel SB-263/GXH-1	4-3/8 x 8-3/4 x 19	23
1	Rack MT-453F	18 x 22 x 76-1/2	210
1	Recorder, Frequency Time RD-122/GXH-1	7-7/32 x 14-13/32 x 14-27/32	29
1	Amplifier, AF AM-778/GXH-1	8-3/4 x 10 x 19	34
1	Control Reel C-1161/GXH-1	5-1/2 x 6-31/32 x 19	6

SECT 4 OF 5

NAVSHIPS 94200.4

**DIRECTORY OF ELECTRONICS
TEST EQUIPMENT**

(CONTINUED)

PREPARED BY
U.S. NAVY
ELECTRONICS SUPPLY OFFICE
GREAT LAKES, ILLINOIS



TEST SET

AN/MPM-2

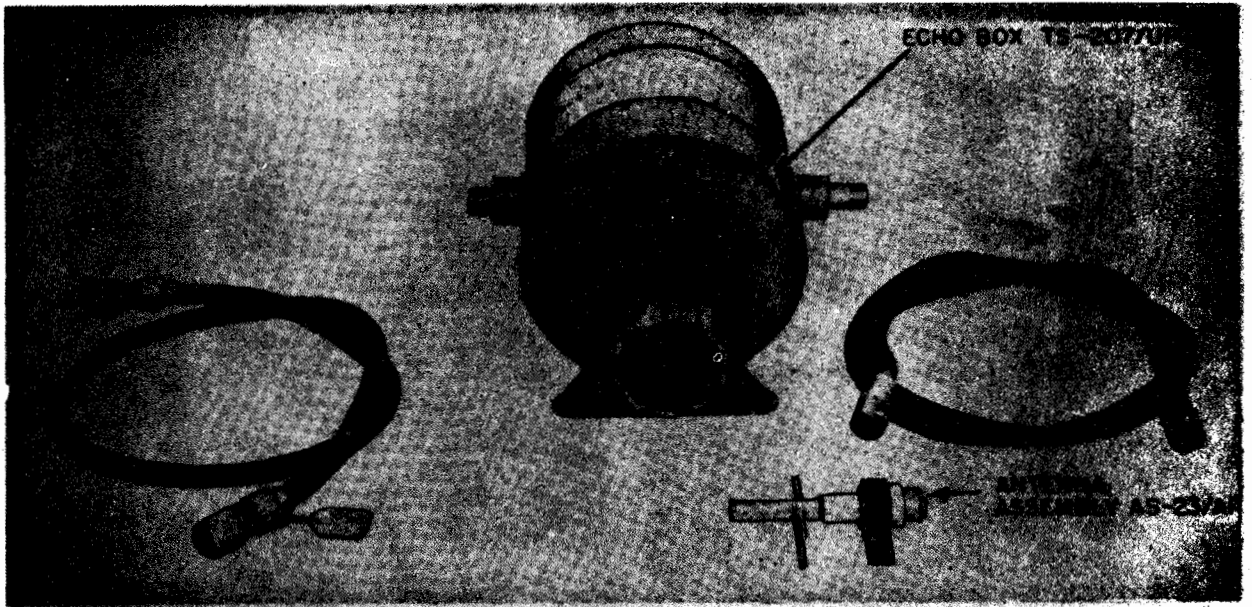

Echo Box TS-207/UP

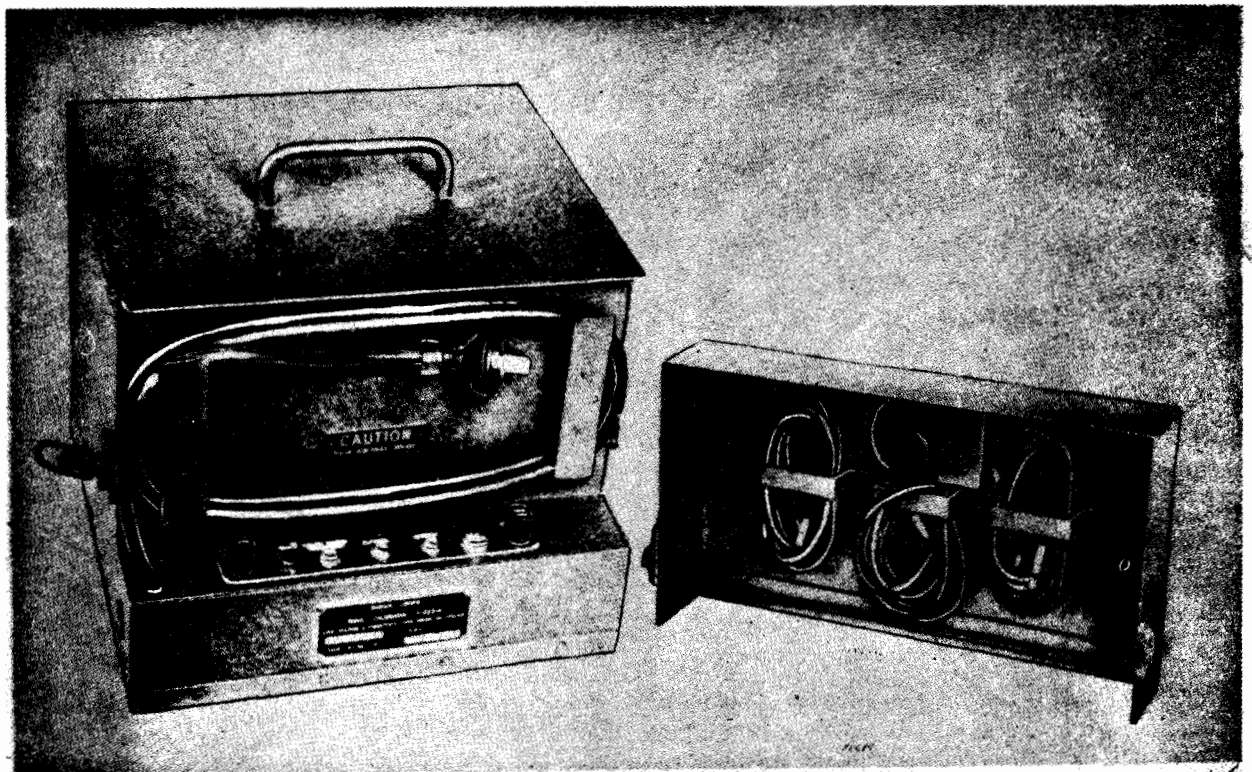

Range Calibrator I-223-A

AN/MPM-2

TEST SET

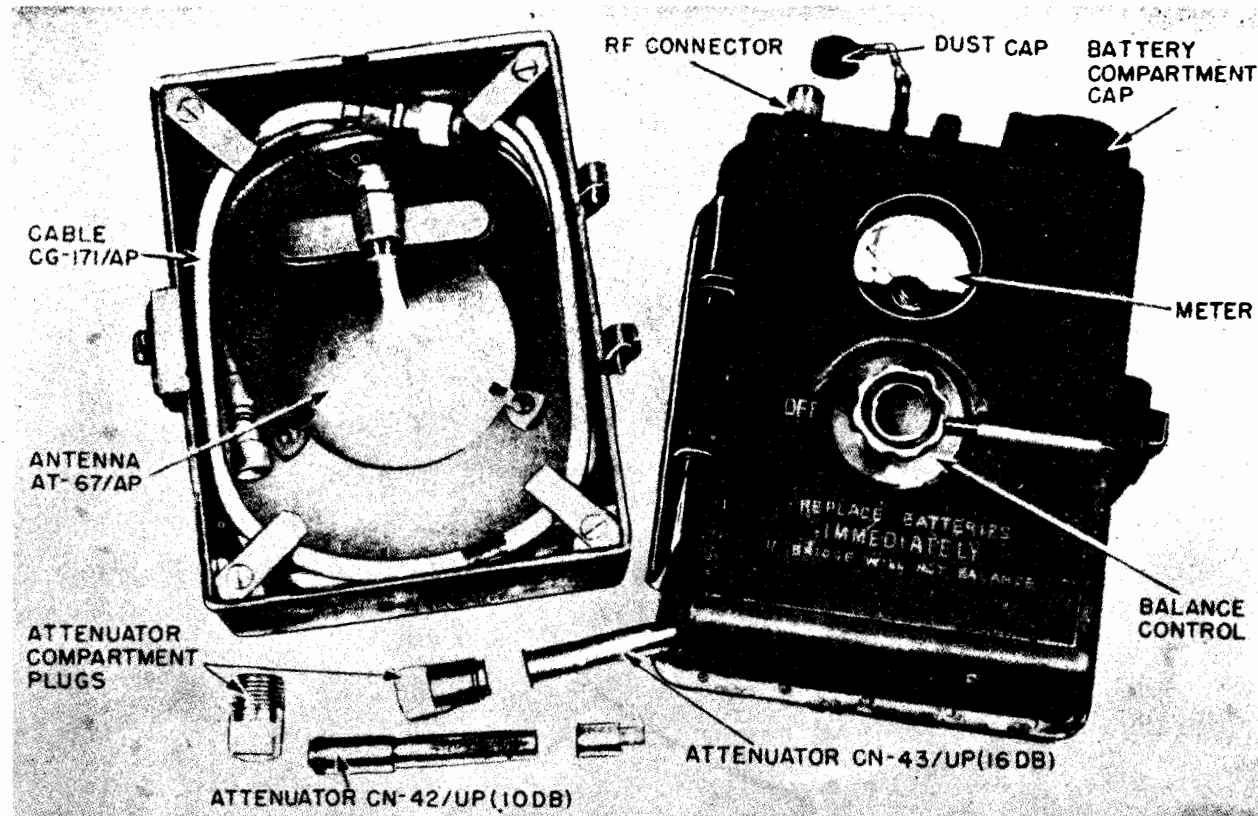

Power Meter TS-125/AP

FUNCTIONAL DESCRIPTION

The AN/MPM-2 is an assembly of test equipments consisting of a dummy antenna, an echo box, a fluxmeter, a power meter, a range calibrator, signal generators, a wavemeter test set and all necessary cables and couplings. The equipment is designed for mounting in Truck M-30 and is used for special field and depot maintenance of Radio Sets SCR-584 and SCR-784 and Radio Equipment RC-184.

No field changes in effect at time of preparation (21 February 1957).

RELATION TO OTHER EQUIPMENT

Used with, but not part of Test Set AN/GRM-1.

ELECTRICAL AND MECHANICAL CHARACTERISTICS

SIGNAL GENERATOR FREQUENCY RANGES: 15 to 50 mc. 2700 to 2900 mc.

R.F. OUTPUT: Sine Wave, modulated at 400 or 8200 cps or unmodulated.

CALIBRATOR OUTPUT.

SINE WAVE: 163.94 mc.

SYNCHRONIZING PULSE: 240 pps.

PULSES: Having rise time of 0.25 usec.

FREQUENCY MEASUREMENTS: 2400 to 3400 mc; wavemeter.

FLUX DENSITY RANGE: 1200 to 9600 gaussess.

POWER OUTPUT.

REGULATED: -105 v.

UNREGULATED: +300 v.

HALF-WAVE RECTIFICATION: +4500 v.

FULL-WAVE RECTIFICATION; UNREGULATED: +300 v.

FULL-WAVE RECTIFICATION, REGULATED: +270 v.

POWER SOURCE REQUIRED: 110 v, 50 to 60 cps, single ph; 6 v, 12 v, and 24 v batteries.

TUBE AND/OR CRYSTAL COMPLEMENT

Tubes: Not Available.

(10) 1N21B

Total Crystals: (10)

TEST SET

AN/MPM-2

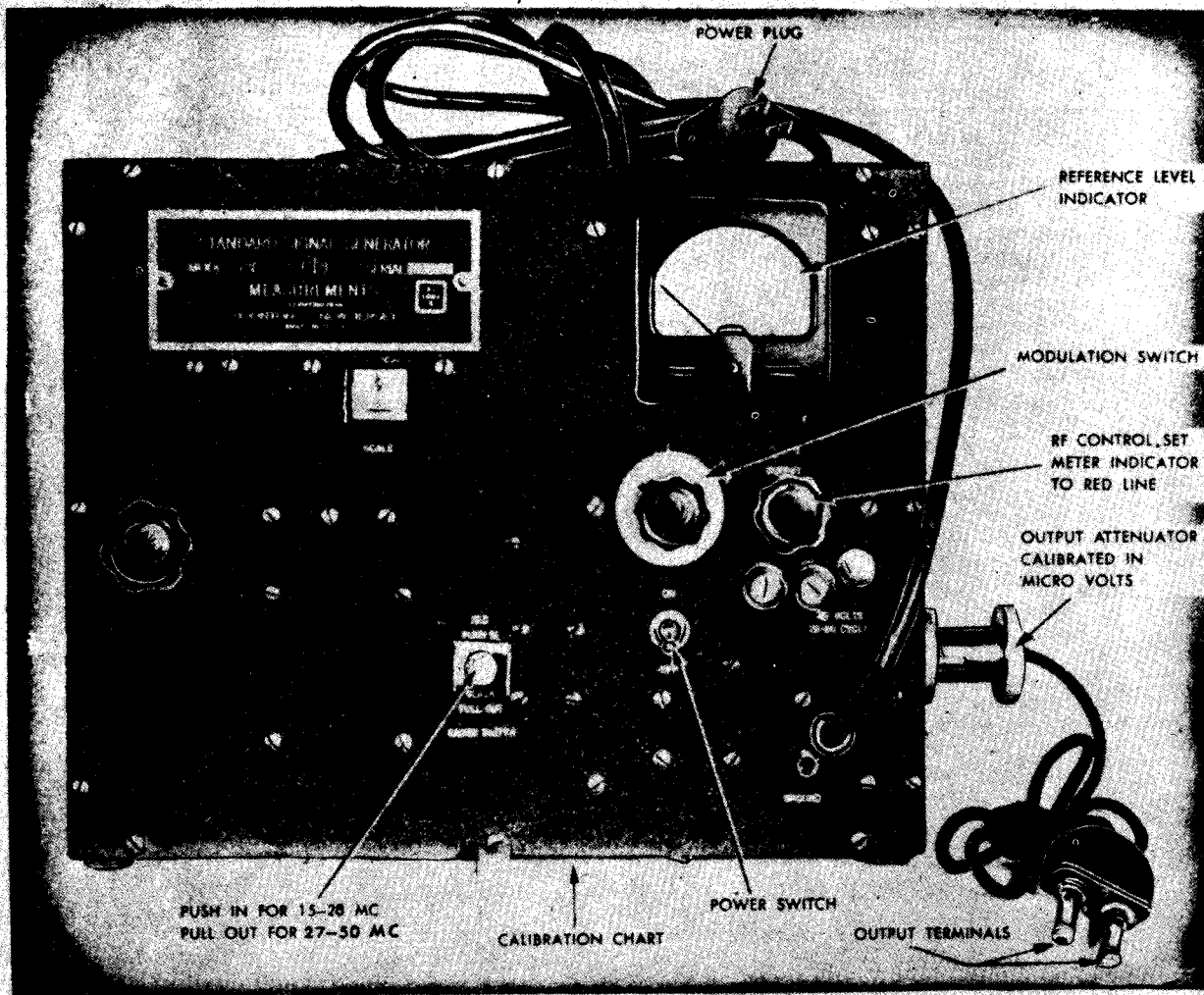

Signal Generator TS-343/U

REFERENCE DATA AND LITERATURE

TM11-1211: War Department Technical Manual
for Test Set - AN/MPM-2.

TYPE CLASSIFICATION
DESIGN COGNIZANCE TASSA
PROCUREMENT COGNIZANCE
STOCK NO.
R.D.B. IDENT. NO.

EQUIPMENT SUPPLIED DATA

QUANTITY PER EQUIPT	NAME AND NOMENCLATURE	OVERALL DIMENSIONS (inches)	WEIGHT (lbs.)
1	Echo Box TS-207/UP		
1	Fluxmeter TS-15A/AP	4-1/2 X 6 X 10	6-1/2
1	Power Meter TS-125/AP	5-5/16 X 7-7/8 X 10	12
1	Range Calibrator I-223-A	9-3/4 X 11-11/16 X 12-1/4	31
1	Signal Generator TS-343/U		
1	Signal Generator TS-155B/UP	10 X 10 X 17	55
1	Wave meter Test Set TS-117/GP	2-3/4 X 4-3/4 X 5-7/8	7

AN/MPM-2

TEST SET

EQUIPMENT SUPPLIED DATA

QUANTITY PER EQUIPT	NAME AND NOMENCLATURE	OVERALL DIMENSIONS (inches)	WEIGHT (lbs.)
1	Receiver Rectifier RA-66-B	8-3/4 X 13-1/4 X 19	75
1	Plan Position Rectifier RA-69-B	8-3/4 X 13-1/4 X 19	75
1	Altitude Converter Rectifier RA-70-A	8-3/4 X 13-1/4 X 19	75
1	Range Rectifier RA-72-B	8-3/4 X 13-1/4 X 19	75
1	Dummy Antenna TS-208/MPM	3/4 X 1-5/8	
1	Test Antenna TS-210/MPM		
2	Adapter M-358		
2	Adapter M-359		
1	Adapter U-18/UP		
1	Crystal Adapter UG-119/UP		
1	Antenna Assy AS-23/AP		
4	Cabinet BE-96		
10	Lamp LM-54		
1	Case, for Neon Lamps	1 X 3-1/2 X 6	
2	Chest CH-273		
2	Plug PL-258		
2	Radio Frequency Jack UG-3X/U		
1	Terminal Box J-74/MPM		
1	Thermometer NO. 213		
1	Thermometer Case NO. 600		
10	Tube 1N21-B		
1	Spanner Wrench MX-219/UP (Supplied with Echo Box TS-207/UP)		
1	Handle, for spinner motor shaft seal, nut wrench, Miller Tool Co MTM-SL-15 or equal		
1	Wrench, Miller Tool Co. MTM-SL-12		
1	Wrench, elevation, potentiometer gear Miller Tool Co MTM-SL-20		
1	Wrench, potentiometer gear nut, Miller Tool Co MTM-SL-21		
1	Wrench, Spinner Motor Flange, Miller Tool Co MTM-SL-19		
1	Wrench, Spinner Motor Seat, Miller Tool Co. MTM-SL-18		
1	Wrench, spinner motor shaft seal nut, Miller Tool Co., MTM-SL-15		
1	Puller, universal Coupling, Miller Tool Co. MTM-SL-22		
1	Pliers, ring, Forged Steel Products Co. Vacuum Grip NO 70-A, Chrysler dwg. No. 1061644		
1	Wrench, spinner Motor locknut Miller Tool Co. MTM-SL-14 - Chrysler Dwg. 1061625		
1	Cord CG-70/MPM	180 lg	
1	Cord CG-71/MPM	72 lg	
1	Cord CG-135/UP	300 lg	
1	Cord CG-136/UP	432 lg	
1	Cord CX-245/UP	98-1/2 lg	
1	Cord CX-246/UP	98-1/2 lg	
1	Cord CX-247/UP	97-1/2 lg	
1	Cord CX-248/UP	97-1/2 lg	
1	Cord CX-249/UP	99 lg	
2	Cord CX-250/UP	99 lg	
1	Cord CX-251/UP	60 lg	
2	Cord CX-252/UP	98-1/2 lg	
1	Cord CX-253/UP	98-1/2 lg	
6	Cord CX-254/UP	98 lg	
1	Cord CX-255/UP	62 lg	
2	Cord CX-256/UP	96 lg	
1	Cord CX-257/UP	98-1/2 lg	

UNCLASSIFIED
October 1957

Test-Combination and Group

TEST SET

AN/MPM-2

EQUIPMENT SUPPLIED DATA

QUANTITY PER EQUIPT	NAME AND NOMENCLATURE	OVERALL DIMENSIONS (inches)	WEIGHT (lbs.)
1	Cord CX-258/UP	98-1/2 lg	
1	Cord CX-259/UP	99 lg	
2	Cord CX-260/UP	99 lg	
1	Cord CX-261/UP	82 lg	
1	Cord CX-262/UP	96 lg	
1	Cord CX-263/UP	96 lg	

UNCLASSIFIED

4.10 AN/MPM-2: 5

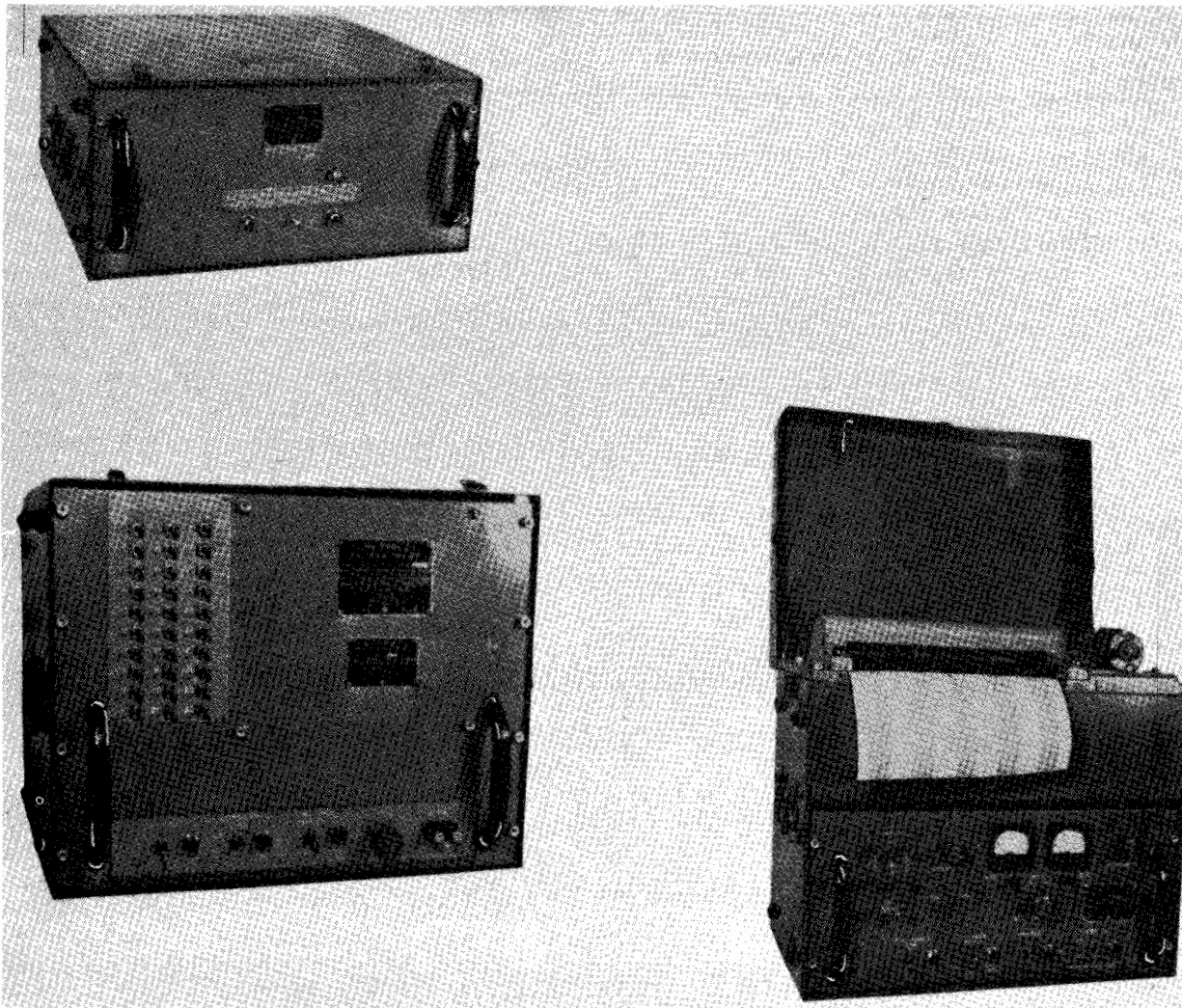
DISTORTION TEST SET**AN/PRM-3**

Distortion Test Set AN/PRM-3

FUNCTIONAL DESCRIPTION

Distortion Test Set AN/PRM-3 is designed to establish the relative distortion of any given piece of telegraph equipment. It makes possible the detection of the distortion of the telegraph circuit or its components,

such as the transmission line, line relays, repeaters and the receiver. The resultant distortion is recorded permanently on electrosensitive paper and may then be studied to give an accurate analysis of the transmission quality of each component of the telegraph circuit.

April 1959

Test-Combination and Group

AN/PRM-3

DISTORTION TEST SET

The AN/PRM-3 records a given signal transmitted over the telegraph circuit as lines representative of intervals of time.

No field changes in effect at time of preparation (30 March 1959).

- (1) 6AC7 (1) 6AG7 (11) 6AS7G
- (5) 6H6 (1) 6SJ7 (1) 6SL7
- (11) 6SN7 (1) 931A

Total Tubes: (39)

(1) J-108

Total Crystals: (1)

ELECTRICAL AND MECHANICAL CHARACTERISTICS

OPERATING POWER RQMT: 115 v, 60 cps, single ph.

REFERENCE DATA AND LITERATURE

Technical Manual for Distortion Test Set AN/PRM-3.

MANUFACTURER'S OR CONTRACTOR'S DATA

Alden Products Co., Brockton, Mass.
Contract NObsr-42506, 29 June 1948.

TYPE CLASSIFICATION
DESIGN COGNIZANCE BUSHIPS
PROCUREMENT COGNIZANCE
STOCK NO.
R.D.B. IDENT. NO. 10

TUBE AND/OR CRYSTAL COMPLEMENT

- (3) OD3 (2) 5V4G (2) 5517

EQUIPMENT SUPPLIED DATA

QUANTITY PER EQUIPT	NAME AND NOMENCLATURE	OVERALL DIMENSIONS (inches)	WEIGHT (lbs.)
1	Distortion Test Set Includes:		
1	Amplifier-Power Supply AM-374/PRM-3	8-3/4 X 19 X 20	
1	Amplifier-Converter AM-375/PRM-3	8-3/4 X 12-1/8 X 19	
1	Pulse Generator SG-41/PRM-3	12-1/8 X 15 X 19	
1	Signal Telegraph Recorder RD-73/PRM-3	8-1/2 X 13-5/8 X 19	
1	Case CY-806/PRM-3	9-1/2 X 19-1/2 X 22	
1	Case CY-807/PRM-3	15-1/8 X 18-1/2 X 19-1/2	
1	Case CY-798/PRM-3	13-1/2 X 16 X 19-1/2	
1	Set of Cables		

UNCLASSIFIED

October 1957

Test Combination and Group

TELEPHONE TEST SET

AN/PTM-6

FUNCTIONAL DESCRIPTION

The AN/PTM-6 is used to measure the electrical characteristics of field phones, hand set, head and chest sets, microphones, receivers, generators, ringers, capacitors and telephone dials. It operates from a sound source in the frequency range from 500 to 2500 cps.

No field changes in effect at time of preparation (25 March 1957).

RELATION TO OTHER EQUIPMENT

Interchangeable with all models of Test Set I-142-() except for maintenance parts.

ELECTRICAL AND MECHANICAL CHARACTERISTICS

OUTPUT: 10 Dynes per sq centimeter.

FREQUENCY RANGE: 500 to 2500 cps.

INPUT IMPEDANCE: 10000 ohms.

INDICATOR RANGE: 0.0002 to 3.8 v, 0.05 to 4 uf.

OPERATING CURRENT: 6, 8.5 and 3.5 ma at 16-2/3 cps.

POWER SOURCE REQUIRED: 3, 12, 24 and 135 v DC.

MANUFACTURER'S OR CONTRACTOR'S DATA

Precision Associates, Inc., Brooklyn, N.Y.; 25694-Phila-53-34.

TUBE AND/OR CRYSTAL COMPLEMENT

Tubes and Crystals: Not Available.

REFERENCE DATA AND LITERATURE

Nomenclature Card for Test Set, Telephone AN/PTM-6 dated 2 Jan 1955.

TYPE CLASSIFICATION	
DESIGN COGNIZANCE	TASSA
PROCUREMENT COGNIZANCE	MIL-T-11003 (Sig C)
STOCK NO.	
R.D.B. IDENT. NO.	

EQUIPMENT SUPPLIED DATA

QUANTITY PER EQUIPT	NAME AND NOMENCLATURE	OVERALL DIMENSIONS (inches)	WEIGHT (lbs.)
1	Test Set, Telephone TS-903/G		
1	Sound Calibrator TS-550()/G		
1	Test Set I-142-()		

UNCLASSIFIED

RADIO TEST SET

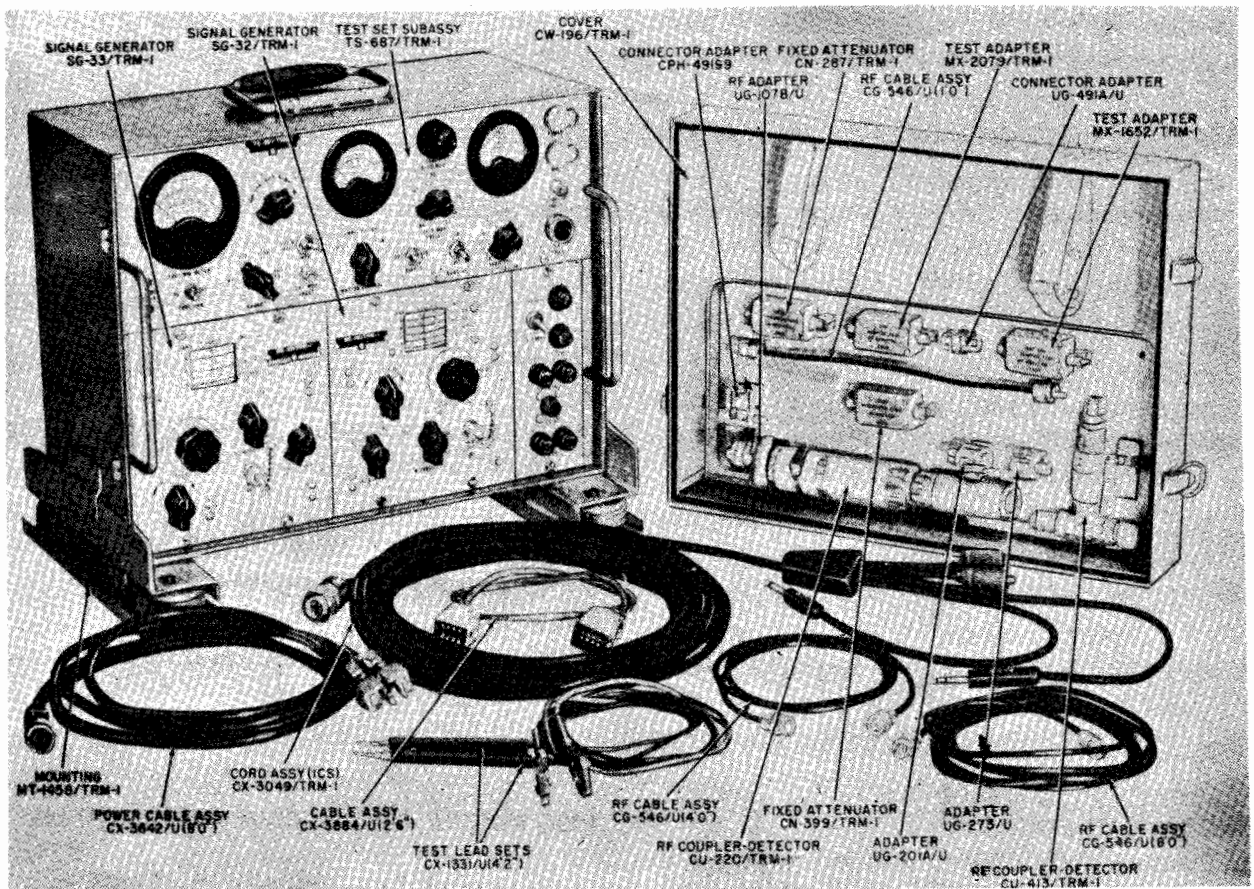

Radio Test Set AN/TRM-1

FUNCTIONAL DESCRIPTION

The AN/TRM-1 provides, in a composite portable test instrument, the facilities necessary to perform go-no go pre-flight performance tests on aircraft receiving, transmitting, and navigation equipment in the frequency range from 190 kilocycles (kc) to 400 megacycle (mc), and voice inter-communication equipment in the audio frequency range. The application and use of the AN/TRM-1 depends to a large extent, upon statistical data listing satisfactory readings for equipments in various installations.

No field changes in effect at time of preparation (25 June 1959).

EQUIPMENT REQUIRED BUT NOT SUPPLIED

(1) Power Source 115 vAC, 50 to 1000 cps, single phase (The voltage regulated power supply within the test set allows operation with line voltage variations from 103.5 to 1265).

ELECTRICAL AND MECHANICAL CHARACTERISTICS

SIGNAL GENERATOR SG-32/TRM-1 (LMHF)

FREQUENCY RANGE: 0.19 to 30 mc.

NUMBER OF FREQUENCY BANDS: 5.

FREQUENCY DIAL ACCURACY: $\pm 1\%$ of indicated frequency.

AN/TRM-1**RADIO TEST SET**

R.F. OUTPUT VOLTAGE: 2.5 to 100,000 microvolts across 50 ohm external load. Attenuator adjustable in nine separate steps of 2.5, 5, 10, 25, 50, 100, 1K, 10K, 100K microvolts.

MODULATION CAPABILITY: 0 to 60% from 200 to 6000 cps.

INTERNAL MODULATION: 1000 cps $\pm 10\%$.

EXTERNAL MODULATION: 200 to 6000 cps applicable at EXT MOD INPUT jack.

SIGNAL GENERATOR SG-33/TRM-1 (V/UHF)

FREQUENCY RANGE: 30 to 400 mc.

NUMBER OF FREQUENCY BANDS: 3.

BAND RANGES

BAND A: 30 to 70 mc.

BAND B: 70 to 170 mc.

BAND C: 170 to 400 mc.

FREQUENCY DIAL ACCURACY: $\pm 2\%$ of indicated frequency.

R.F. OUTPUT VOLTAGE: 2.5 to 100,000 microvolts across 50 ohm external load. Attenuator adjustable in nine separate steps of 2.5, 5, 10, 25, 50, 100, 1K, 10K, 100K microvolts.

MODULATION CAPABILITY: 0 to 60% from 200 to 6000 cps.

INTERNAL MODULATION: 1000 cps $\pm 10\%$.

EXTERNAL MODULATION: 200 to 6000 cps.

Applicable at EXT MOD INPUT jack.

TEST SET SUBASSEMBLY TS-687/TRM-1

TRANSMITTER PERFORMANCE TESTS

FREQUENCY RANGE: 190 kc to 400 mc.

POWER RANGE: For use only w/transmitters capable of power output from 3 to 100 W.

MODULATION METERING: 0 to 100% modulation.

OVER MODULATION PEAKS: 60 to 120%.

AUDIO OUTPUT VOLTAGE

FREQUENCY: 1000 cps $\pm 10\%$.

OUTPUT: 3 v rms across external 82 ohm load (0 db).

VOLT/MILLIWATT METER

MILLIWATT METER

RANGE: 0 to 10, 0 to 100, 0 to 1000 mw.

ACCURACY: W/in 5% of full scale reading between 200 to 6000 cps.

INPUT IMPEDANCE: 300 ohms.

AC VOLTMETER

RANGE: 0 to 3, 0 to 30, 0 to 300 v AC.

ACCURACY: W/in 5% of full scale reading between 50-6000 cps.

SENSITIVITY: 5000 ohms per volt.

DC VOLTMETER

RANGE: 0 to 3, 0 to 30, 0 to 300 and 0 to 600 v DC.

ACCURACY: W/in 5% of full scale reading.

SENSITIVITY: 20,000 ohms per volt.

OPERATING POWER CONSUMPTION: Approx 60 W at 115 v.

OPERATING POWER RQMT: 103.5 to 126.5 v, 50 to 1000 cps, single ph, AC, Nominal 115 v AC.

MANUFACTURER'S OR CONTRACTOR'S DATA

Trad Television Corp., Asbury Park, N. J.

Dwg. No. 102-D-784.

Contract NOas 51-819.

TUBE AND/OR CRYSTAL COMPLEMENT

(1) CK710	(1) OA2WA
(2) 5726-6AL5W	(2) 5814A
(1) 6AN5WA	(1) 6AU6WA
(1) 6F4	(1) 6X4WA
(1) 6005-6AQ5W	

Total Tubes: (11)

(2) 1N126	(3) 1N82A
-----------	-----------

Total Crystals: (5)

REFERENCE DATA AND LITERATURE

AN16-30TRM1-1: Technical Manual for Radio Test Set AN/TRM-1.

TYPE CLASSIFICATION
DESIGN COGNIZANCE BUAER
PROCUREMENT COGNIZANCE MIL-T-6907 (ADR)
STOCK NO.
R.D.B. IDENT. NO.

UNCLASSIFIED

February 1960

Test-Combination and Group

RADIO TEST SET

AN/TRM-1

EQUIPMENT SUPPLIED DATA

QUANTITY PER EQUIPT	NAME AND NOMENCLATURE	OVERALL DIMENSIONS (inches)	WEIGHT (lbs.)
1	Test Set Sub Ass'y TS-687/TRM-1	6-7/8 X 12-3/8 X 17-1/4	19
1	Signal Generator (LMHF) SG-32/TRM-1	6-13/16 X 6-7/8 X 6-5/8	6-1/2
1	Signal Generator (V/UHF) SG-33/TRM-1	6-5/8 X 6-13/16 X 6-7/8	8
1	R.F. Coupler-Detector (LMHF) CU-220/TRM-1	1-3/8 dia X 10-7/16	
1	R.F. Coupler-Detector (V/UHF) CU-413/TRM-1	1-1/4 X 3-11/16 X 4-13/32	
1	Test Set Cover CW-196/TRM-1	2-1/8 X 12-11/16 X 17-9/16	
2	Mounting (Shock) MT-145R/TRM-1		
1	Test Adapter (Antenna Simulator) MX-1652/TRM-1	31/32 x 1-5/32 X 2-7/8	
1	Test Adapter (50 Ohm Shunt) MX-2079/TRM-1	15/16 X 1-1/8 X 3	
1	Fixed Attenuator (6 db) CN-399/TRM-1	15/16 X 1-1/8 X 3	
2	Test Lead Set CX-1331/U (4' 2")	50 lg	
1	Electrical Cord Ass'y CX-3049/TRM-1		
1	Power Electrical Cable Ass'y CX-3642/U (8' 0")	94 lg	
1	R.F. Cable Ass'y CG-546/U (1' 0")	12 lg	
1	R.F. Cable Ass'y CG-546/U (4' 0")	48 lg	
1	R.F. Cable Ass'y CG-546/U (8' 0")	94 lg	
1	R.F. Adapter UG-107B/U		
1	Connector Adapter UG-491A/U		
1	Connector Adapter NT-49194		
1	Adapter UG-201A/U		
1	Adapter UG-273/U		
1	Special Purpose Electrical Cable Ass'y CX-3884/U (2' 6")	30 lg	

UNCLASSIFIED

4.10 AN/TRM-1: 3

December 1962

6625-539-9030

RADIO TEST SET AN/TRM-3

g Service:

FSN: 6625-519-2024 W/S

Functional Class:

USA

USN

USAF

PE CLASS:

MANUFACTURER'S NAME/CODE NUMBER: Transatron Incorporated.

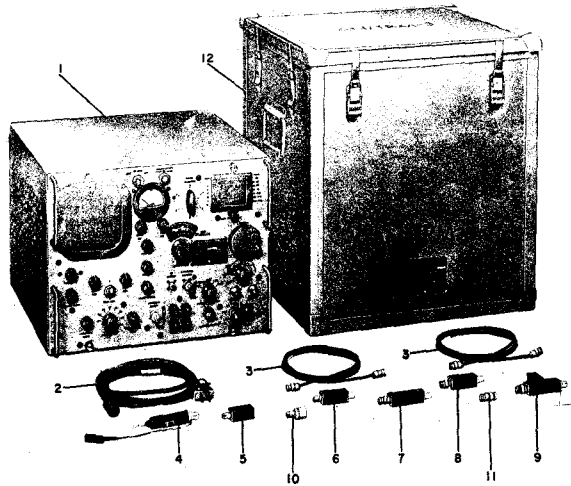

Index No.	Description	Nomenclature
1	Sweep Generator	SG-24/TRM-3
2	Electrical Power Cable Assembly	CX-3277/U (8 ft 0 in.)
3	Cords	CG-409A/U (8 ft 0 in.)
4	Test Prods	MX-1981/TRM-3
5	Electrical Dummy Load	DA-138/TRM-3
6	Impedance Matching Network	MX-1983/TRM-3
7	Test Adapter	MX-1982/TRM-3
8	Fixed Attenuator	CN-374/TRM-3
9	R-f Coupler-Detector	CU-506/TRM-3
10	Connector Adapter	UG-201/U
11	Connector Adapter	UG-491A/U
12	Test Set Case	CY-1941/TRM-3

Radio Test Set AN/TRM-3

FUNCTIONAL DESCRIPTION:

Radio Test Set AN/TRM-3 is designed to provide low-power rf test signals in the frequency range of 15 to 400 mc, at a power level within the range of 0.1 uv to 100,000 uv when terminated in a 50 ohm load. The test set provides cw, am and fm signals having bandwidths from 600 kc to 160 mc, at center frequencies within the range of 15 to 400 mc. These output signals are used for testing, calibrating, aligning, and setting gain adjustments of IF and RF tuned circuits. The purpose of the oscilloscope section of the instrument is to display the bandpass curve of the equipment under test, when frequency modulated test signals are utilized. Internally generated marker pips are provided for calibrating the oscilloscope sweep trace line in terms of frequency.

No field changes in effect at time of preparation (12 December 1961).

AN/TRM-3 RADIO TEST SET

TECHNICAL CHARACTERISTICS:

FREQUENCY RANGE: 15 to 400 mc, 6 bands.

SWEEP DEVIATION, FM OPERATION: Porm 2% to porm 20% of the center frequency.

SWEEP RATE, FM OPERATION: 25 cps, porm 10%.

OUTPUT LEVEL VARIATION, FM OPERATION: Less than porm 0.5 db from center frequency, at any deviation control setting.

ACCURACY OF FREQUENCY CALIBRATION, AM AND CW OPERATION: Porm 1%, with the dial corrector set at mid-position (porm 0.02%, by use of internal crystal marker generator).

DIAL CORRECTOR RANGE: Porm 6.0 to porm 8.0 mc at 400 mc.

AMPLITUDE MODULATION: 400 cps porm 2%. Percent modulation continuously adjustable from 0 to 50%; 30% modulation point indicated by red line on calibrated meter scale.

RF OUTPUT VOLTAGE: Continuously adjustable from 0.1 uv min to 100,000 uv (0.1 v) max, when operated into rated load at 50 ohms.

HARMONIC CONTENT

AT OUTPUT LEVELS OF 100 UV OR MORE: At least 40 db below output level.

AT OUTPUT LEVELS OF LESS THAN 100 UV: 20 db below output level.

SPURIOUS AMPLITUDE MODULATION: 0.5% max.

SPURIOUS FREQUENCY MODULATION: 0.01% max.

OUTPUT LEVEL CALIBRATION ACCURACY: Accuracy of attenuator dial is porm 2 db or better, when connected to rated load.

RATED LOAD: Nominally 50 ohms resistive.

OUTPUT CIRCUIT STANDING WAVE RATIO: Less than 1.3:1 (SWR 2.5 db).

FREQUENCY MARKER SPACINGS: 200 kc, 1 mc, 5 mc, and 20 mc, porm 0.02%.

MARKER PIP AMPLITUDE: From 0 to at least 1/2 in. total vertical displacement on crt screen.

CATHODE RAY TUBE: 5 in. screen.

VERTICAL INPUT ATTENUATOR: Step type, with 7 ranges from 0 to 60 db attenuation.

BANDWIDTH, OSCILLOSCOPE VERTICAL DEFLECTION AMPLIFIER: Max high frequency response of 15 kc, at the 6 db points.

POWER REQUIREMENTS: 103.5 to 126.5 v rms, 50 to 1,000 cyc, 225 W.

RELATION TO OTHER EQUIPMENT: None.

EQUIPMENT REQUIRED BUT NOT SUPPLIED: None.

MAJOR COMPONENTS

QTY	ITEM	STOCK NUMBERS	DIMENSIONS (INCHES)	WEIGHT (LBS)
1	—Radio Test Set AN/TRM-3 includes:			
1	Sweep Generator SG-24/TRM-3		13-3/16 x 17 x 17	66.5
1	Test Set Case CY-1941/TRM-3		18-3/8 x 20-1/16 x 21	35.0
1	Electrical Power Cable Ass'y CX-3277/U or CX-3135/U		96 lg	0.53
1	RF Coupler-Detector CU-506/TRM-3		3/4 x 4 x 3-1/2	0.29
1	Impedance Matching Network MX-1983/TRM-3		3/4 x 3/4 x 3-1/8	0.16
1	Electrical Dummy Load DA-138/TRM-3		3/4 x 3/4 x 2-1/16	0.09

4.10 AN/TRM-3: 2

RADIO TEST SET AN/TRM-3

QTY	ITEM	STOCK NUMBERS	DIMENSIONS (INCHES)	WEIGHT (LBS)
1	Fixed Attenuator CN-374/TRM-3		3/4 x 3/4 x 3-3/8	0.16
1	Test Prod MX-1981/TRM-3		3/4 dia x 4-11/16	0.11
1	Test Adapter MX-1982/TRM-3		3/4 x 3/4 x 4	0.16
2	Cords CG-409A/U		60 lg	0.26
1	Connector Adapter UG-201/U		3/4 dia x 1-9/16	0.05
1	Connector Adapter UG-491A/U		9/16 dia x 1-5/16	0.05

REFERENCE DATA AND LITERATURE:

- NAVAER 16-30TRM3-501: Handbook of Operating Instructions for Radio Test Set AN/TRM-3.
 NAVAER 16-30TRM3-502: Handbook of Service Instructions for Radio Test Set AN/TRM-3.
 NAVAER 16-30TRM3-503: Handbook of Overhaul Instructions for Radio Test Set AN/TRM-3.
 NAVAER 16-30TRM3-504: Illustrated Parts Breakdown for Radio Test Set AN/TRM-3.
 TO 33A1-3-99-1: Handbook of Operating Instructions for Radio Test Set AN/TRM-3.
 TO 33A1-3-99-2: Handbook of Service Instructions for Radio Test Set AN/TRM-3.
 TO 33A1-3-99-3: Handbook of Overhaul Instructions for Radio Test Set AN/TRM-3.
 TO 33A1-3-99-4: Illustrated Parts Breakdown for Radio Test Set AN/TRM-3.

TUBE, CRYSTAL AND/OR SEMI-CONDUCTOR DATA:

- TUBES: (1) 0A2WA (2) 0B2WA (1) 2X2A (1) 5R4WGA (1) 5UP1 (3) 6X4W (6) 12AT7WA
 (5) 12AX7 (6) 5654/6AK5W (3) 5814A (5) 6005/6AQ5W (1) 6481
- CRYSTALS: (2) CR-18/U (1) CR-25/U (1) CR-33/U
- SEMI-CONDUCTORS: (1) G7B (G.E.) (1) K20 (Kemtron) (1) 1N69 (1) 1N81

SHIPPING DATA

PKGS	VOLUME (CU FT)	WEIGHT (LBS)
------	----------------	--------------

PROCUREMENT DATA

PROCURING SERVICE: DESIGN COG: USN, BuWeps
 SPEC &/OR DWG: MIL-S-8663A(AER)

CONTRACTOR	LOCATION	CONTRACT OR ORDER NO.	APPROX. UNIT COST
Transitron Incorporated	Manchester, N. H.	NOas-54-803 N383-45300A	

December 1956

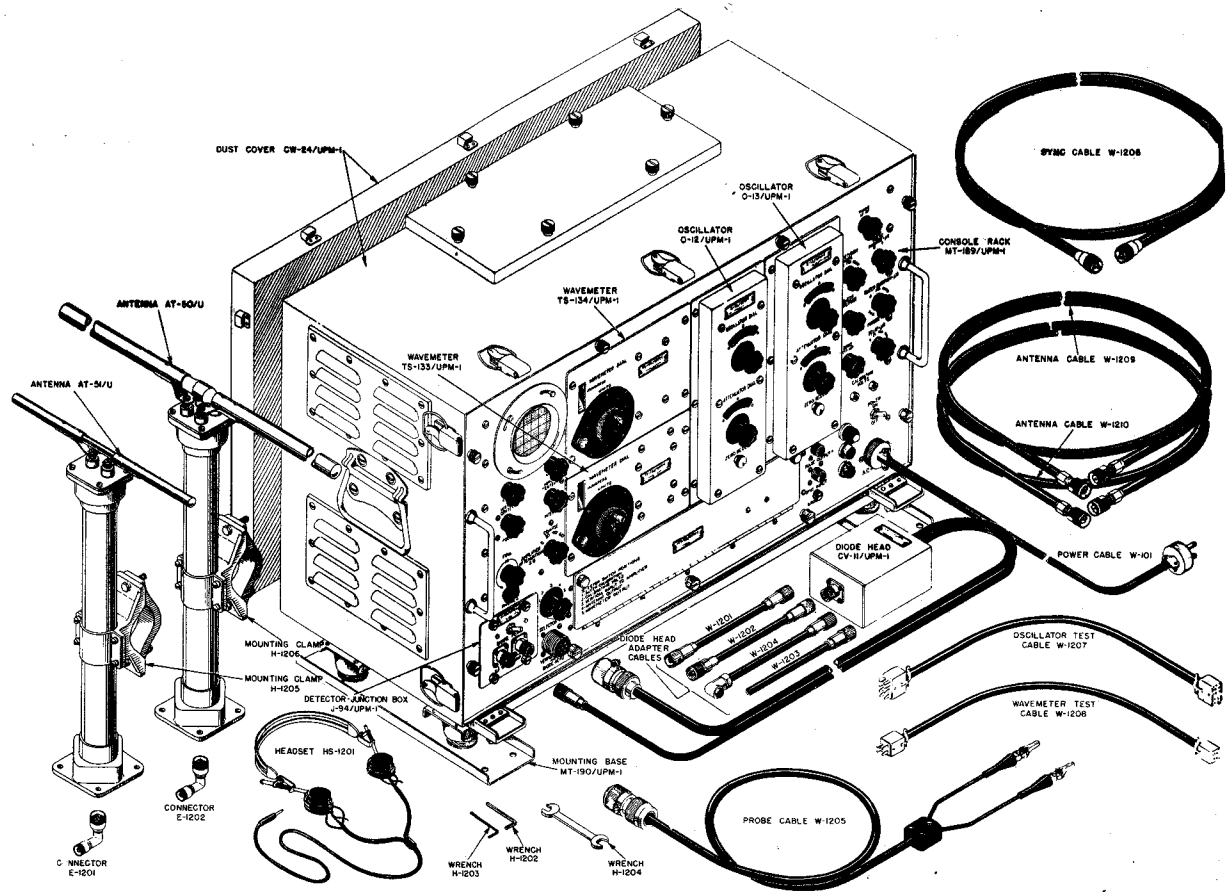
RADIO MAINTENANCE EQUIPMENTS**AN/UPM-1,1A,1B**

Radar Maintenance Equipment AN/UPM-1B

FUNCTIONAL DESCRIPTION

The AN/UPM-1, AN/UPM-1A and AN/UPM-1B are radar test sets designed to perform maintenance tests on Mark 3 and Mark 3G IFF equipment.

They operate within the 155 to 235 mc and the 460 to 570 mc frequency bands, and can be synchronized by, and trigger the equipment under test. Their primary functions are to set and measure frequency, measure pulse amplitude and time duration, visually present waveforms for observation, monitoring transponders, and measuring their sensitivity and recovery periods.

Each set contains a pulse and sweep generator, a video amplifier, an oscilloscope, two wavemeters, two oscillators, a detector junction box, and pick-up devices such as probe cables and a diode head.

These units are basically identical with the exception of accessories. The AN/UPM-1 does not include antenna AT-50/U or AT-51/U. The AN/UPM-1A includes antenna AT-50/U

and AT-51/U but does not include the mounting base MT-190/UPM-1.

The AN/UPM-1B includes antenna AT-50/U, AT-51/U and mounting base MT-190/UPM-1.

Data on this sheet reflects the following field changes, FC No. 1 and 4 (18 July 1956).

RELATION TO OTHER EQUIPMENT

Equipment Required but not Supplied: 1 AC power source, 1 AC voltmeter.

ELECTRICAL AND MECHANICAL CHARACTERISTICS**FREQUENCY RANGE**

BAND 1: 460 to 570 mc.

BAND 2: 155 to 235 mc.

SWEEP DURATIONS: 40, 200 or 2000 us, (each $\pm 30\%$).

REPETITION RATES: 60, 250 or 2500 pps, (250, 500 or 1200 pps for modified maintenance equipment AN/UPM-1) (each $\pm 30\%$).

UNCLASSIFIED

4.10 AN/UPM-1: 1

AN/UPM-1,1A,1B RADIO MAINTENANCE EQUIPMENTS

December 1956

SWEEP CALIBRATION MARKERS: 5, 20 or 200 us,
(each $\pm 5\%$ except first three).

VIDEO AMPLIFIER CHARACTERISTICS

GAIN: At least 70 db.

BANDWIDTH: 6 db down at 300 cps and 750 kc.

ATTENUATION DATA

STEPS: 0, 20, 40 or 60 db.

CONTINUOUS: 0 to 20 db.

VIDEO OUTPUT PULSE: 50 v open circuit or 25 v across 500 ohms. 2 or 7 us in width and rise time approximately 0.5 us from 30% to 90% of peak amplitude.

SIGNAL GENERATOR DATA

OUTPUT

HIGH FREQUENCY: 0 to 1 v rms maximum, during pulse into 500 ohm load.

LOW FREQUENCY: 0.5 v rms maximum, during pulse into 500 ohm load.

RF ATTENUATION: 90 db below 1v rms during pulse.

PULSE WIDTHS: 2 (+60% - 30%) or 7 ($\pm 30\%$) us.

RISE TIME: 0 to 7 us from 30% to 90% of peak amplitude.

INTERVAL BETWEEN PAIRED PULSES: 25, 100 or 800 us. (25, 100 or 400 us for modified AN/UPM-1).

WAVEMETER DATA

SENSITIVITY: 0 to 1 inch scope deflection with 500 uw pulse power.

ACCURACY: ± 0.25 of 1% of true frequency.

RESETTABILITY: ± 0.10 of 1% of original frequency.

POWER SOURCE REQUIRED: 80, 115 or 230 v AC, 60 to 1000 cps, single phase, 140 to 210 W.

MANUFACTURER'S OR CONTRACTOR'S DATA

Hazeltine Electronics Corp., New York, N. Y.

Contract NXsa-36958 (AN/UPM-1).

Contract NXsr-33782 (AN/UPM-1A,1B).

Contract NXsr-45455 (AN/UPM-1A,1B).

Approximate Cost: \$2940.00, with equipment spares.

TUBE AND/OR CRYSTAL COMPLEMENT

(9) 6SN7WGTA	(2) 6J6WA	(2) 6SH7
(1) 2X2A	(1) OD3W	(1) 3BP1
(1) 5U4G	(1) 6AG7Y	(3) 6C4WA
(3) 9005	(2) 9006	

Total Tubes: (26)

REFERENCE DATA AND LITERATURE

NAVSHIPS 900,845: Technical Manual for Radar Maintenance Equipments AN/UPM-1, 1A, 1B.

TYPE CLASSIFICATION
DESIGN COGNIZANCE BUSHIPS
PROCUREMENT COGNIZANCE RE-9089A (AN/UPM-1)
STOCK NO.
R.D.B. IDENT. NO. 10.1.3 (AN/UPM-18)

EQUIPMENT SUPPLIED DATA

QUANTITY PER EQUIPT	NAME AND NOMENCLATURE		OVERALL DIMENSIONS (inches)	WEIGHT (lbs.)
AN/UPM-				
1	1A	1B		
1	1	1	Console Rack MT-189/UPM-1 including:	66.0
1	1	1	Power Cable	120 lg
1	1	1	Wavemeter TS-134/UPM-1	6 X 6 X 8-1/8
1	1	1	Wavemeter TS-133/UPM-1	5-1/2 X 7-3/4 X 8-1/8
1	1	1	Oscillator O-13/UPM-1	5-1/8 X 8-5/8 X 11-1/2
1	1	1	Oscillator O-12/UPM-1	5-1/8 X 8-5/8 X 11-1/2
1	1	1	Diode Head CV-11/UPM-1	2-1/2 X 3-3/4 X 5-7/8
1	1	1	Detector-Junction Box J-94/UPM-1	3-5/8 X 3-7/8 X 4
1	1	1	Dust Cover CW-24/UPM-1	14-7/8 X 19-5/8 X 32
1	1	1	Antenna AT-51/U including:	3-3/4 X 12-1/2 X 20-3/4
1	1	1	Antenna-Mounting Clamp	
1	1	1	Antenna AT-50/U including:	3-3/4 X 20-3/4 X 32-1/2
1	1	1	Antenna-Mounting Clamp	
1	1	1	Mounting Base MT-190/UPM-1	2-5/8 X 14-3/4 X 30-1/8
1	1	1	Syne Cable	120 lg

December 1956

RADIO MAINTENANCE EQUIPMENTS

AN/UPM-1,1A,1B

EQUIPMENT SUPPLIED DATA

QUANTITY PER EQUIPT			NAME AND NOMENCLATURE	OVERALL DIMENSIONS (inches)	WEIGHT (lbs.)
AN/UPM-					
1	1A	1B			
1	1	1	Probe Cable	42 lg	0.5
1	1	1	Head Set	2 X 7-1/2 X 7-1/2	1.0
1	1	1	Visor	3-9/16 X 4	0.25
1	1	1	Set Diode-Head Adapter Cables terminated with:		
1	1	1	Connector UG-12/U, blank	12 lg	0.15
1	1	1	Connector UG-12/U, UG-12/U	12 lg	0.25
1	1	1	Connector UG-12/U, NT-49190	12 lg	0.25
1	1	1	Connector UG-12/U, British 10H/701	12 lg	0.25
1	1	1	Set Test Cables consisting of:		
1	1	1	Oscillator Test Cable	25 lg	0.40
1	1	1	Wavemeter Test Cable	25 lg	0.25
	2	2	Antenna Right-Angle Connector, UG-27/U	3/4 X 1-15/16 X 1-5/8	0.15(ea.)
	2	2	Antenna Cables RG-8/U terminated with:	50 ft	5.3(ea.)
	4	4	Connector NT-49268	3/4 dia X 2	0.05(ea.)
1	1	1	Allen Head Wrench #8	5/64 X 3/4 X 2-1/4	0.03
1	1	1	Allen Head Wrench #6	1/16 X 1/2 X 1-3/4	0.03
1	1	1	Open End Wrench 1/2 inch	5/32 X 1-1/16 X 4-1/2	0.12

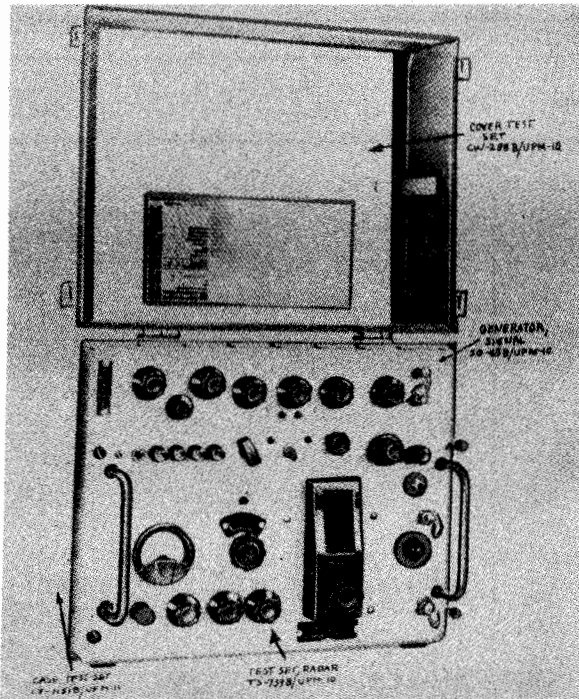
RADAR TEST SET**AN/UPM-10, 10B**

Radar Test Set AN/UPM-10B

are similar to the AN/UPM-56 which has pulsed output characteristics of great precision.

Equipment Required but not Supplied: (1) Oscilloscope TS-34/AP Series or equivalent Synchroscope.

ELECTRICAL AND MECHANICAL CHARACTERISTICS**SIGNAL GENERATOR DATA**

FREQUENCY RANGE: 8500 to 9600 mc.

FREQUENCY MODULATION

SWEEP RATE: 0 to 6 mc per usec.

EXCURSION OF SWEEP: 0 to 40 mc.

SQUARE WAVE MODULATION

RATE AND DURATION: 1250 cps and 50% duty cycle, self-synchronous.

PULSE MODULATION

LENGTH: 1.0 usec, 2.35 usec fixed, 0.2 to 5.0 usec variable for AN/UPM-10; 0.55 usec, 1.0 usec, 2.35 usec fixed, 0.2 to 5.0 usec variable for AN/UPM-10B.

DELAY: 1 usec max fixed, 10 to 200 usec variable.

TRIGGER PULSES: 200 to 2500 pps at +25 to +200 v peak or -30 to -200 v peak.

RF POWER OUTPUT

RED-DOT POSITION OF TEST SWITCH: -7 to -40 dbm for AN/UPM-10, -7 to -45 dbm for AN/UPM-10B.

RECV POSITION OF TEST SWITCH: -42 to -80 dbm for AN/UPM-10, -42 to -85 dbm for AN/UPM-10B.

FREQUENCY METER

RANGE: 8500 to 9600 mc.

ABSOLUTE ACCURACY: ± 2.5 mc at 25 deg C and 60% relative humidity.

RELATIVE ACCURACY: ± 1.0 mc for frequency increments of less than 60 mc.

RF POWER LEVEL WATTMETER

RANGE: +7 to +30 dbm at RF connector.

ACCURACY: ± 2 db for AN/UPM-10, ± 1.5 db for AN/UPM-10B.

SAWTOOTH SWEEP

AMPLITUDE: -0 to -100 v.

SLOPE: -0 to +2 v per usec.

TRIGGER AMPLIFIER VOLTAGE GAIN: 500 v.

IMPEDANCE DATA

TRIGGER INPUT: 10000 ohms min.

RF OUTPUT: 50 ohms nom.

POWER OUTPUT: 210 W operating, 25 W stand-by.

POWER REQUIREMENTS

AN/UPM-10: 115 v $\pm 10\%$, 50 to 1000 cps, single ph.

AN/UPM-10B: 115 v $\pm 10\%$, 50 to 1600 cps, single ph.

MANUFACTURER'S OR CONTRACTOR'S DATA

General Communication Company, Boston, Mass.

FUNCTIONAL DESCRIPTION

The AN/UPM-10 and AN/UPM-10B are portable microwave signal generators and test sets, used for testing and adjusting beacon equipment and radar systems that operate within the band of 8500 to 9600 megacycles. They measure the power and frequency of external signals, and supply output signals that are frequency modulated, pulse modulated, square wave modulated, or unmodulated continuous wave. The output is synchronized from an external source except for the square wave output which is synchronized to an internal source.

Power measurements are made by the use of a calibrated attenuator and meter. Frequency response tests are made by use of an oscilloscope, such as Oscilloscope TS-34/AP Series, which is used together with these equipments.

The AN/UPM-10B differs from the AN/UPM-10 only in addition of controls, and minor electrical and physical changes.

No field changes in effect at time of preparation (29 January 1957).

RELATION TO OTHER EQUIPMENT

Test Set TS-739/UPM-10 component of AN/UPM-10 is similar to TS-147/UP Series. SG-63/UPM-10 component of AN/UPM-10 is similar to TS-35/AP. The AN/UPM-10 and AN/UPM-10B

Test-Combination and Group
AN/UPM-10, 10B

RADAR TEST SET

Contract NObsr-49223, dated 3 June 1950.
Lewyt Manufacturing Company, Long Island
City, N.Y.

Contract NObsr-59929, dated 31 January
1955.

Approximate Cost: \$1,950.00 (AN/UPM-10)
with equipment spares.

Approximate Cost: \$777.00 (AN/UPM-10B)
with equipment spares.

(1) 1N23B
Total Crystals: (1)

REFERENCE DATA AND LITERATURE

NAVSHIPS 91549: Technical Manual for Radar
Test Set AN/UPM-10.

NAVSHIPS: Technical Manual for Radar Test
Set AN/UPM-10B.

TUBE AND/OR CRYSTAL COMPLEMENT

(1) 2K25 (2) OC3W (1) 5R4WGB
(2) 6AH6 (1) 6AN5WA (1) 6SH7
(2) 6SL7WGT (1) 6X4WA (1) 6Y6G
(2) 5727/2D21W (2) 6189
Total Tubes: (16)

TYPE CLASSIFICATION	
DESIGN COGNIZANCE	BUSHIPS
PROCUREMENT COGNIZANCE	SHIPS-T-1661
STOCK NO.	
R.D.B. IDENT. NO.	

SHIPPING DATA

NUMBER OF BOXES	CONTENTS AND IDENTIFICATION	VOLUME (Cu.Ft.)	OVERALL DIMENSIONS (inches)	WEIGHT PACKED (lbs.)
1	Radar Test Set AN/UPM-10 or AN/UPM-10B	4.4	15.5 X 20.0 X 24.3	95

EQUIPMENT SUPPLIED DATA

QUANTITY PER EQUIPT	NAME AND NOMENCLATURE	OVERALL DIMENSIONS (inches)	WEIGHT (lbs.)
1	AN/UPM-10		
1	Radar Test Set AN/UPM-10 Consisting of:	12.8 X 14.9 X 19.5	65
	(1) Test Set, Radar TS-739/UPM-10	9.5 X 10 X 17.3	28
	(1) Generator, Pulse SG-63/UPM-10	3.5 X 8.4 X 17.3	12
	(1) Case, Test Set CY-1151/UPM-10	8.1 X 14.9 X 18	6
	(1) Cover, Test Set CW-288/UPM-10	6.1 X 14.5 X 19.5	19
	(1) Pick-up Antenna AT-68/UP	2.3 X 4.5 X 6.8	0.3
	(1) Cord CG-638/U	72 lg	1
	(1) Cord CG-92A/U	96 lg	1
	(1) Cord CG-337/U	72 lg	0.3
	(1) Coaxial Cable Connector NT-49192		0.2
	(1) Set of Operating Maintenance Repair Parts		1
	(2) Technical Manual NAVSHIPS 91549		2
	AN/UPM-10B		
1	Radar Test Set AN/UPM-10B consisting of:	12.8 X 14.9 X 19.5	65
	(1) Test Set, Radar TS-739B/UPM-10	9.5 X 10 X 17.3	28
	(1) Generator, Signal SG-63B/UPM-10	3.5 X 8.4 X 17.3	12
	(1) Case, Test Set CY-1151B/UPM-10	8.1 X 14.9 X 18	6
	(1) Cover, Test Set CW-288B/UPM-10	6.1 X 14.5 X 19.5	19
	(1) Antenna, Horn, Wave Guide AT-68/UP	2.3 X 4.5 X 6.8	0.3
	(1) Cable Assembly, RF CG-530/U	72 lg	1
	(1) Cable Assembly, RF CG-92D/U	96 lg	1
	(1) Cable Assembly, Power, Electrical CX-3891/U	72 lg	0.3
	(1) Connector, Adapter UG-273/U		0.2
	(1) Set of Operating Maintenance Repair Parts		1
	(2) Technical Manual		2

26 February 1963

Cog Service: USA FSN: F6625-542-1290

ELECTRICAL POWER TEST SET AN/UPM-100

Functional Class: 10.1.5

USA

USN

USAF

TYPE CLASS:

Used by

MANUFACTURER'S NAME/CODE NUMBER: The Winslow Co., Inc., (66150).

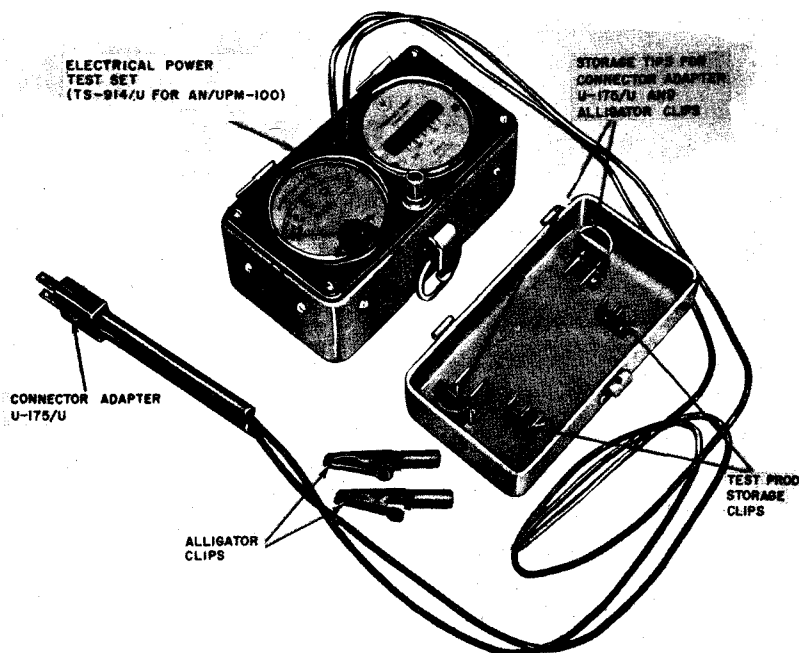

Electrical Power Test Set AN/UPM-100

FUNCTIONAL DESCRIPTION:

Electrical Power Test Set AN/UPM-100 is a portable test set used to make voltage and frequency measurements of 60 cps power circuits. The tester is connected to the measurement points by two test prods which may be connected to alligator clips or plugged into Connector Adapter U-175/U.

No field changes in effect at time of preparation (16 November 1960).

TECHNICAL CHARACTERISTICS:

FREQUENCY RANGE: 58 to 62 cps.

VOLTAGE RANGE: 0 to 150 v, 0 to 300 v.

POWER CONSUMPTION: 3 w.

ACCURACY OF FREQUENCY CALIBRATION: Porm 3% of indicated frequency.

ACCURACY OF VOLTAGE CALIBRATION: Porm 2% of full scale value.

AN/UPM-100 ELECTRICAL POWER TEST SET

RELATION TO OTHER EQUIPMENT:

This equipment is similar in purpose, operation, and appearance to AN/UPM-93, except that the AN/UPM-93 makes voltage and frequency measurements on 400 cps power circuits. This equipment also replaces all models of Test Set I-209().

EQUIPMENT REQUIRED BUT NOT SUPPLIED: None.

MAJOR COMPONENTS

QTY	ITEM	STOCK NUMBERS	DIMENSIONS (INCHES)	WEIGHT (LBS)
1	Electrical Power Test Set AN/UPM-100 includes:			
1	Electrical Power Test Set TS-914/U		2-5/8 x 3-1/4 x 6-1/8	2.42
1	Connector Adapter U-175/U			
2	Alligator Clip			

REFERENCE DATA AND LITERATURE:

TM11-6625-303-12: Technical Manual for Electrical Power Test Sets AN/UPM-93 and AN/UPM-100.

TUBE, CRYSTAL AND/OR SEMI-CONDUCTOR DATA:

TUBES: None used.

CRYSTALS: None used.

SEMI-CONDUCTORS: None used.

SHIPPING DATA

PKGS	VOLUME (CU FT)	WEIGHT (LBS)
1		

PROCUREMENT DATA

PROCURING SERVICE: USA
SPEC &/OR DWG:;

DESIGN COG: USA, Sig C

CONTRACTOR	LOCATION	CONTRACT OR ORDER NO.	APPROX. UNIT COST
The Winslow Co., Inc. Model no. 365-1	Union, New Jersey		

4.10 AN/UPM-100: 2

April 1958

RADAR TEST SET

AN/UPM-4(XN-11)

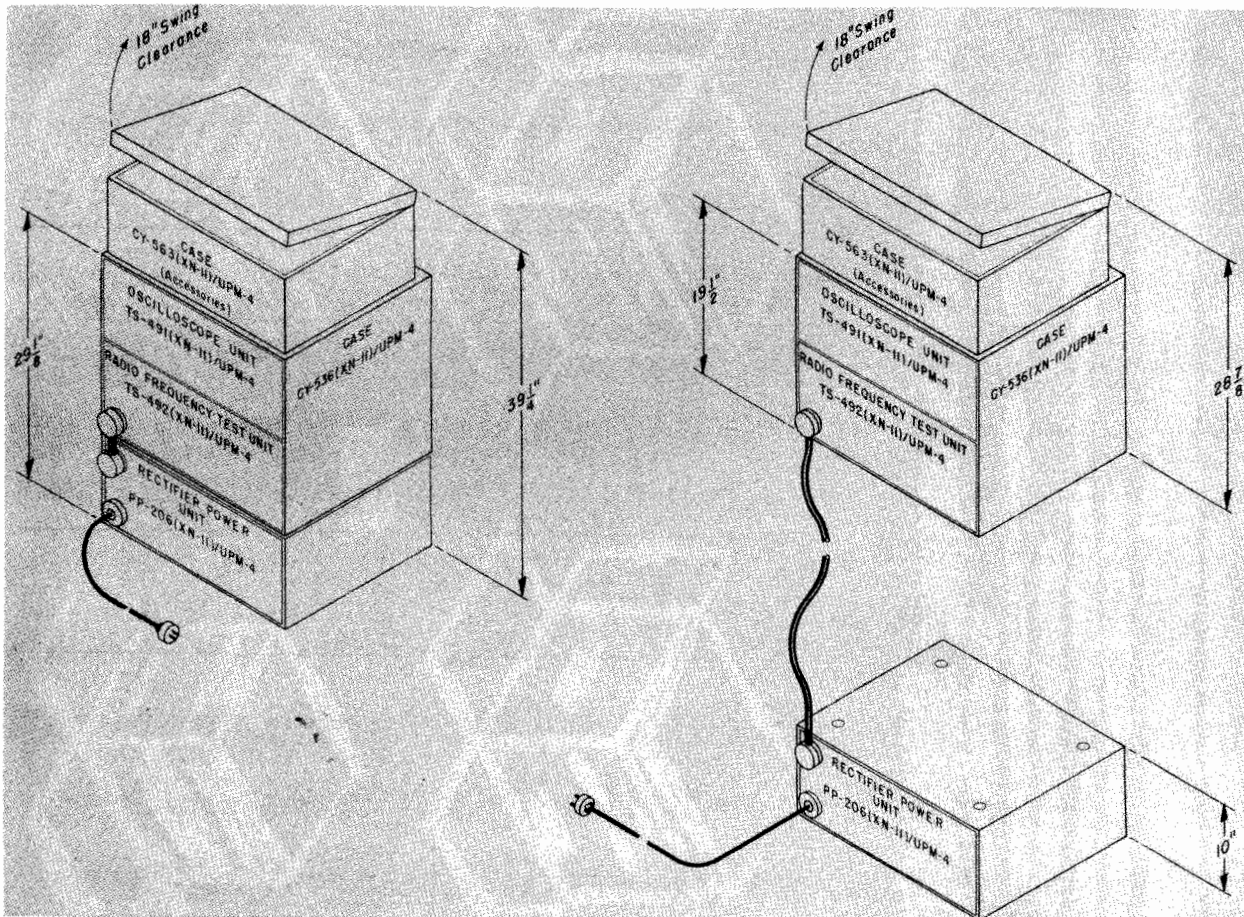

Radar Test Set AN/UPM-4(XN-11)

FUNCTIONAL DESCRIPTION

The AN/UPM-4(XN-11) is a transportable equipment designed to make most of the tests and measurements required in the servicing of any of the units of the Mark 5 IFF system. It measures transmitter frequency and power output, receiver sensitivity, and bandwidth of transponders, beacons, and interrogator responders. It will also perform tests on transponders and beacons for receiver coding and slow code indication, and tests on interrogator responders for transmitter coding.

It is used to perform tests on Radar Sets AN/APX-6, AN/CPX-3, AN/CPX-4, AN/SPX-1, AN/SPX-2, and Radar Recognition Set AN/APX-7.

No field changes in effect at time of preparation (28 May 1958).

ELECTRICAL AND MECHANICAL CHARACTERISTICS

OSCILLOSCOPE DATA

PRESENTATION: 3 in. CR tube.

SYNCHRONIZATION

POLARITY (EXTERNAL): Negative or positive pulses.

PULSE REPETITION RATE

EXTERNAL: 25 to 4100 pps.

INTERNAL: 50 to 4100 pps.

SWEEP DATA

DURATION: 3.5, 12, 50, 500, and 2600 usec.

Test-Combination and Group

AN/UPM-4(XN-11)**RADAR TEST SET**

April 1958

DELAY: 3 to 175 usec in respect to sync pulse, 0.7 usec min with delay multivibrator out of circuit.

SUPPRESSOR PULSE DATA

POLARITY: Positive.
AMPLITUDE: 10 to 30 v for 500 ohms in parallel with 175 uuf, or 3 v for 75 ohms in parallel with 1100 uuf.

DURATION: 1 to 5 usec.
DELAY: Approx 0.7 usec.
RISE TIME: Approx 15 v per usec.

DELAYED TRIGGER OUTPUT PULSE

POLARITY: Positive.
AMPLITUDE: 50 to 100 v for 500 ohms in parallel with 175 uuf, or 10 v for 75 ohms in parallel with 1100 uuf.

DURATION: 1 to 3 usec.
RISE TIME: 0.15 usec.
DELAY: 3 to 175 usec in respect to sync pulse, approx 0.3 usec in respect to suppressor pulse.

RF TEST UNIT DATA**CODER DATA**

TYPE PULSE PRODUCED: Video.
POLARITY
EXTERNAL: Positive or negative.
INTERNAL: Negative.

OUTPUT PULSES

TYPE	DURATION	SPACING
Paired	0.9 \pm 0.2 usec	3 \pm 0.5 usec
Paired	0.9 \pm 0.2 usec	5 \pm 0.5 usec
Paired	0.9 \pm 0.2 usec	8 \pm 0.5 usec
Single	1.15 \pm 0.15 usec	
Single	2.5 \pm 0.2 usec	
Paired	1.15 \pm 0.15 usec	8 \pm 1 usec
Quadruple	1.15 \pm 0.15 usec	8 \pm 1 usec

VIDEO CALIBRATOR PULSE (OUTPUT)

TYPE: Rectangular form.
DURATION: 2.5 usec.
AMPLITUDE: 1, 2, 5, or 10 v peak.

RF SIGNAL GENERATOR

FREQUENCY RANGE: 925 to 1165 mc.
RF OUTPUT: 15 to 115 db below 1 v rms.
OUTPUT IMPEDANCE: 53.5 ohms nom.

OUTPUT PULSE

RISE TIME: 0.2 usec.
DECAY TIME: 0.4 usec.
DELAY: 0.3 usec between RF output pulse and coder modulating pulse.

WAVEMETER

TYPE: Quarter-wave resonant cavity.

FREQUENCY RANGE: 925 to 1210 mc.
ACCURACY: \pm 0.7 mc of true frequency.
SENSITIVITY: 0.5 W input to demodulator at lowest duty cycle produces 25% deflection on indicating meter.

DEMODULATOR

POWER INPUT (MAX): 35 and 3500 W.
POWER DISSIPATION: 0.25 and 5 W max average.

POWER REQUIREMENTS: 80, 115, 140, 180, or 230 v \pm 10%, 47 to 2400 cps, single ph, 350 W at 60 cps.

MANUFACTURER'S OR CONTRACTOR'S DATA

General Communications Co, Boston, Mass.
Contract NXsr-65314.

TUBE AND/OR CRYSTAL COMPLEMENT

(1) OA3/VR-75	(1) OB2
(2) 2B22	(1) 3JP1
(1) 5R4GY	(7) 6AG5
(7) 6AK5	(6) 6AL5
(39) 6C4	(3) 6D4
(1) 6L4	(2) 6V6GT/G
(2) 6Y6G	

Total Tubes: (73)

(1) 1N28

Total Crystals: (1)

REFERENCE DATA AND LITERATURE

NAVSHIPS 95022: Technical Manual for Radar Test Set AN/UPM-4(XN-11).

TYPE CLASSIFICATION
DESIGN COGNIZANCE BUSHIPS
PROCUREMENT COGNIZANCE
STOCK NO.
R.D.B. IDENT. NO.

April 1958

RADAR TEST SET

AN/UPM-4(XN-11)

EQUIPMENT SUPPLIED DATA

QUANTITY PER EQUIPT	NAME AND NOMENCLATURE	OVERALL DIMENSIONS (inches)	WEIGHT (lbs.)
1	Oscilloscope Unit TS-491(XN-11)/UPM-4	9-3/4 x 17 x 21-7/8	38.3
1	RF Test Unit TS-492(XN-11)/UPM-4	8-3/4 x 13-7/8 x 21-7/8	30.0
1	Rectifier Power Unit PP-206(XN-11)/UPM-4	10-1/8 x 19-1/8 x 23-7/8	66.8
1	Transponder Probe Antenna AS-332(XN-11)/UP including: Cable RG-58/U	9-1/8 x 9-1/8 x 11-1/2 300 lg	4.8
1	Video Probe MX-604(XN-11)/UP	11/16 dia x 66	0.8
1	Video Probe MX-605(XN-11)/UP	11/16 dia x 66	0.8
1	Video Probe MX-606(XN-11)/UP	2-1/4 dia x 66	0.7
1	Case CY-536(XN-11)/UPM-4	19 x 19-1/2 x 23-7/8	28.8
1	Case CY-563(XN-11)/UPM-4	9-7/8 x 17-1/4 x 22-3/4	29.0
2	Case CY-574(XN-11)/UPM-4	21-3/4 x 22-1/2 x 26-3/8	31.0
1	Adapter UG-309/U	7/8 dia x 1-1/2	0.1
4	Adapter UG-273/U	23/32 dia x 1-1/4	0.4
1	Adapter UG-201/U	3/4 dia x 1-9/16	0.1
1	Cable Assembly	60 lg	
1	Cable Assembly	7-3/16 lg	
1	Cable Assembly	62-1/2 lg	
1	Cable Assembly DCOP-3	120 lg	
1	Cable Assembly RG-58/U	120 lg	
1	Cable Assembly RG-58/U	60 lg	
1	Cable Assembly RG-62/U	15 lg	
4	Cable Assembly RG-62/U	60 lg	
9	Calibration Chart		
3	Alligator Clip		
1	Set of Tools		
1	Set of Equipment Spares		

RADAR TEST SET

AN/UPM-4A,-4B

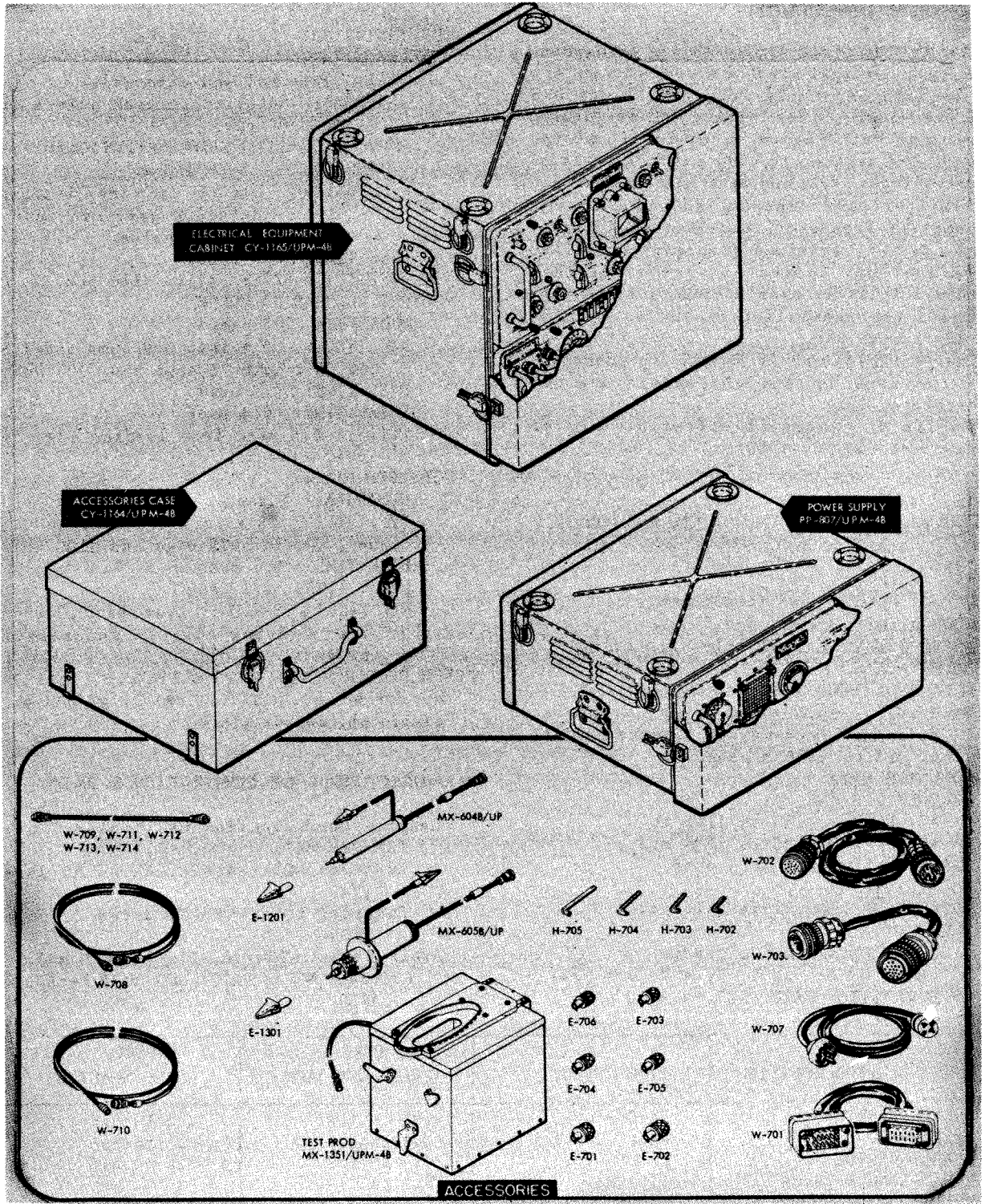

Radar Test Set AN/UPM-4B

Test-Combination and Group

AN/UPM-4A,-4B

RADAR TEST SET

FUNCTIONAL DESCRIPTION

The AN/UPM-4A and AN/UPM-4B are transportable test equipments that operate in the 925 to 1225 megacycle frequency range and have been designed for testing and performing corrective maintenance on equipment of the Mark 10 IFF system. It will perform tests on interrogators, transponders and beacons for transmitter power output and pulse shape, transmitter frequency, receiver sensitivity and bandwidth, receiver frequency, waveform investigation, coding and decoding. They feature a built-in oscilloscope unit to give a visual representation of the wave forms met during testing.

The AN/UPM-4A and AN/UPM-4B are functionally the same but the components are not interchangeable.

No field changes in effect at time of preparation (29 May 1958).

ELECTRICAL AND MECHANICAL CHARACTERISTICS

SIGNAL GENERATOR DATA

FREQUENCY RANGE: 925 to 1225 mc.

MODULATION: Pulse.

POWER OUTPUT: 21 db below 1 v rms.

WAVEMETER DATA

FREQUENCY RANGE: 925 to 1225 mc.

ACCURACY: ± 0.7 mc when measuring oscillator frequency or external pulses of 0.5 to 3500 W peak.

DEMODULATOR DATA

FREQUENCY RANGE

AN/UPM-4A: 950 to 1215 mc.

AN/UPM-4B: 925 to 1225 mc.

INPUT IMPEDANCE: 53.5 ohms.

VIDEO CALIBRATOR

TYPE PULSE: Positive polarity.

PULSE DATA

DURATION: 2.5 ± 0.5 usec.

AMPLITUDES: 1, 2, 5, and 10 v $\pm 3\%$.

REPETITION RATE: 47 to 4100 pps.

CODER OUTPUT PULSES

OSCILLOSCOPE DATA

PRESENTATION: 3 in. CR tube.

SYNCHRONIZATION

TYPE: Internal and external.

INTERNAL: Supplies trigger pulses of 47 to 4100 pps.

EXTERNAL (POSITIVE AND NEGATIVE POLARITY)

AMPLITUDE: 5 to 150 v.

DURATION: 1 to 250 usec from leading edge of pulse, 8 usec min from trailing edge of pulse.

RISE TIME: 0.5 usec.

REPETITION RATE: 47 to 4100 pps.

OUTPUT SUPPRESSOR PULSE

DURATION: 3.5 usec.

AMPLITUDE: 20 v into 500 ohms and 175 uuf, 5 v into 75 ohms and 1100 uuf.

RISE TIME: 0.2 usec.

DECAY TIME: 0.4 usec.

DELAY: 0.6 usec from leading edge of internal sync.

TRIGGER PULSE

DURATION: 2 usec.

AMPLITUDE: 65 v into 500 ohms and 175 uuf, 20 v into 75 ohms and 1100 uuf.

RISE TIME: 0.2 usec.

DECAY TIME: 0.5 usec.

DELAY-OUT POSITION: Less than 0.3 usec from leading edge of suppressor pulse.

POWER REQUIREMENTS: 115 v $\pm 15\%$, 57 to 1800 cps for Ser. No. 3151 to 3370 of AN/UPM-4A, single ph, approx 415 W.

MANUFACTURER'S OR CONTRACTOR'S DATA

General Communication Co, Boston, Mass (AN/UPM-4A).

Contract NObsr-43428, dated 30 June 1949.

Contract NObsr-49226, dated 30 June 1950.

Admiral Corp, Chicago, Ill (AN/UPM-4A).

Contract NObsr-52177, dated 22 December 1950

MODE SELECTOR POSITION	TYPE OUTPUT	USEC PULSE DURATION	USEC PULSE SPACING
CHALLENGE-MODE 1	PAIRED	0.7 to 1.2	2.5 to 3.5
CHALLENGE-MODE 2	PAIRED	0.7 to 1.2	4.5 to 5.5
CHALLENGE-MODE 3	PAIRED	0.7 to 1.2	7.5 to 8.5
REPLY-SINGLE PULSE	SINGLE	0.9 to 1.3	
REPLY-DOUBLE PULSE	PAIRED	0.9 to 1.3	12.5 to 19.5
REPLY-EMERGENCY	QUADRUPLE	0.9 to 1.3	12.5 to 19.5

UNCLASSIFIED

April 1958

Test-Combination and Group

RADAR TEST SET

AN/UPM-4A,-4B

Contract NObsr-57415, dated 18 June 1952.
 Contract NObsr-63272, dated 31 March 1953.
 Contract NObsr-63441, dated 30 June 1953.
 Hazeltine Electronics Corp, Little Neck, N.Y. (AN/UPM-4B).
 Contract NObsr-52400, dated 8 May 1951.
 Approximate Cost: \$3700.00 with equipment spares

AN/UPM-4B
 (1) OA3 (1) OB2WA
 (1) 12AT7WA (10) 12AU7
 (1) 2B22 (1) 2C43
 (1) 3JP1 (2) 5R4WGB
 (5) 5654/6AK5W (9) 5726/6AL5W
 (6) 6AG5 (1) 6AS7G
 (2) 6AU6WA (19) 6C4WA
 (3) 6D4 (1) 6L6
 (2) 6V6GTy (1) 6005/6AQ5W
 Total Tubes: (67)
 (1) 1N21B (1) 1N25 (1) 1N34A
 Total Crystals: (3)

TUBE AND/OR CRYSTAL COMPLEMENT

AN/UPM-4A
 (1) OA3 (1) OB2WA
 (1) 12AU7 (2) 2B22
 (1) 2C36 (1) 3JP1
 (1) 5R4WGB (7) 5654/6AK5W
 (7) 5726/6AL5W (8) 6AG5
 (1) 6AS7G (37) 6C4WA
 (3) 6D4 (2) 6V6GTy
 (2) 6005/6AQ5W
 Total Tubes: (75)
 (1) 1N25 (3) 1N34A
 Total Crystals: (4)

REFERENCE DATA AND LITERATURE

NAVSHIPS 91556(A): Technical Manual for Radar Test Set AN/UPM-4A.
 NAVSHIPS 91644: Technical Manual for Radar Test Set AN/UPM-4B.

TYPE CLASSIFICATION
 DESIGN COGNIZANCE BUSHIPS
 PROCUREMENT COGNIZANCE MIL-R-15550A
 STOCK NO.
 R.D.B. IDENT. NO.

EQUIPMENT SUPPLIED DATA

QUANTITY PER EQUIPT	NAME AND NOMENCLATURE	OVERALL DIMENSIONS (inches)	WEIGHT (lbs.)
	AN/UPM-4A		
1	Oscilloscope OS-29/UPM-4A	9.8 X 17.8 X 22.3	44
1	Coder Simulator SM-45/UPM-4A	8.8 X 15 X 22.3	40
1	Power Supply PP-802/UPM-4A	10 X 19.5 X 23.8	70
1	Electrical Instrument Case CY-1154/UPM-4A	19.5 X 19.5 X 24	40
1	Accessories Case CY-1155/UPM-4A	10 X 17.3 X 23.3	37
2*	Electrical Instrument Case CY-1156/UPM-4A	22 X 22.5 X 26	45
1	Test Prod MX-1342/UPM-4A	9 X 9 X 11.8	2.5
1	Set of Accessories		
1	Set of Equipment Spares	13 X 15.5 X 18.5	50
2	Technical Manual NAVSHIPS 91556(A)	1.5 X 9.3 X 11.5	
	AN/UPM-4B		
1	Oscilloscope OS-30/UPM-4B	9-7/8 X 17-3/4 X 21-7/8	41
1	Coder Simulator SM-46/UPM-4B	8-7/8 X 17-3/4 X 21-7/8	34
1	Power Supply Unit PP-807/UPM-4B	10-11/16 X 20-3/16 X 23-3/4	92
1	Video Probe MX-604B/UP	11/16 dia X 6-7/8	0.3
1	Video Probe MX-605B/UP	2-1/4 dia X 8-3/16	0.5
1	Test Prod MX-1351/UPM-4B	8-3/4 X 9-1/2 X 11-7/16	7
1	Electrical Equipment Cabinet CY-1165/UPM-4B	20 X 20-1/4 X 24	39
1	Accessories Case CY-1164/UPM-4B	11-1/16 X 17-5/16 X 23-1/8	38
1	Set of Accessories		
1	Set of Equipment Spares		
1	Technical Manual NAVSHIPS 91644	2 X 9 X 11-1/2	
	NOTE: Not supplied for shipboard installation.		

UNCLASSIFIED

TEST SET, RADAR

AN/UPM-41

FUNCTIONAL DESCRIPTION

The AN/UPM-41 is designed for measurements of sub-clutter visibility at intermediate frequency measures phase-detector characteristics; measures intermediate frequency and video pull jitter, makes both the usual CW and pulsed intermediate frequency signal generator measurements.

No field changes in effect at time of preparation (11 March 1957).

TUBE AND/OR CRYSTAL COMPLEMENT

- | | |
|----------------------|-----------------|
| (1) 6627/OB2WA | (5) 5750/6BE6W |
| (1) 3JP11 | (6) 6D4 |
| (4) 5R4WGB | (1) 6X4WA |
| (2) 6AG7Y | (13) 12AT7WA |
| (3) 5726/6AL5W | (20) 5654/6AK5W |
| (3) 6AS7G | (2) 5725/6AS6W |
| (4) 6AU6WA | (5) 6005/6AQ5W |
| (3) 6C4WA | |
| Total Tubes: (73) | |
| (11) 1N69 | |
| Total Crystals: (11) | |

ELECTRICAL AND MECHANICAL CHARACTERISTICS

SIGNAL GENERATOR

- FREQUENCY RANGE: 27 to 33 mc.
- CALIBRATED OUTPUT: 22.4 uv to 224 mv
- OUTPUT IMPEDANCE: 50 ohm.
- PULSE REPETITION: 50 to 6000 cycles

PULSE JITTER TESTER

- FREQUENCY RANGE: 258 kc sine wave sweep.
- READING ACCURATE: $\pm 10\%$ but not less than 0.01 usec.
- IMPEDANCE: 75 ohm.
- OPERATING POWER: 115 v $\pm 10\%$, 50 to 1000 cps, single ph.

REFERENCE DATA AND LITERATURE

Nomenclature Card for Test Set, Radar AN/UPM-41.

<p>TYPE CLASSIFICATION DESIGN COGNIZANCE BUAER PROCUREMENT COGNIZANCE STOCK NO. R.D.B. IDENT. NO.</p>

EQUIPMENT SUPPLIED DATA

QUANTITY PER EQUIPT	NAME AND NOMENCLATURE	OVERALL DIMENSIONS (inches)	WEIGHT (lbs.)
1	Case, Test Set CY-1318/UPM		
1	Rack, Electrical Equipment MT-1197/UPM		
1	Test Set, Indicator TS-677/UP		
1	Power Supply Assy PP-910/UPM		
1	RF Cable Assy CG-579/U	36 1g	
3	RF Cable Assy CG-546/U	72 1g	
1	Delay Line MX-1448/UP		
1	Delay Line MX-1449/UP		
1	Delay Line MX-1450/UP		
1	Delay Line MX-1451/UP		
1	Delay Line MX-1452/UP		

11 February 1963
Cog Service: USN FSN:

RADAR TEST SET AN/UPM-44
Functional Class: 10.1

USA

USN

USAF

TYPE CLASS:

Used by

MANUFACTURER'S NAME/CODE NUMBER: Sperry Gyroscope Company, (56232).

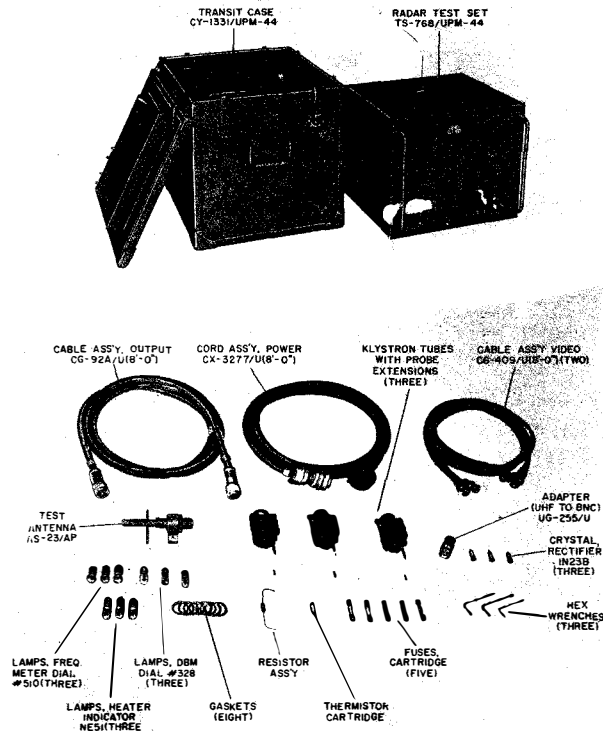

Radar Test Set AN/UPM-44

FUNCTIONAL DESCRIPTION:

Radar Test Set AN/UPM-44 is a complete, portable test equipment designed for use with radar systems operating in the frequency range of 2700 to 3550 mc. It is designed for the measurement of radar transmitter power and frequency; radar receiver bandwidth, sensitivity, recovery time and local-oscillator frequency; tuning of local oscillators; performance testing and/or tuning of duplexers, AFC systems, rotating joints etc.; visual examination of the spectra of magnetrons, local oscillators, test sets, and other equipment in its frequency range; investigation of magnetron pulling; observation of video signals on synchroscope.

No field changes in effect at time of preparation (22 December 1962).

TECHNICAL CHARACTERISTICS:

POWER METER

AN/UPM-44 RADAR TEST SET

FREQUENCY RANGE: 2700 to 3550 mc.

POWER INPUT RANGE: P5 to P30 dbm at input connector.

ACCURACY: Porm 3 db from dial; porm 1 db from correction chart.

FREQUENCY METER

FREQUENCY RANGE: 2700 to 3550 mc.

ABSOLUTE ACCURACY: Porm 3 mc, 2700 to 3550 mc at 25 deg C (77 deg F); porm 1 mc, 2700 to 3550 mc with correction chart.

RELATIVE ACCURACY: Porm 1 mc over any 60 mc interval.

SPECTRUM ANALYZER

TUNING RANGE: 2700 to 3550 mc.

SWEEP SPEEDS: 5 to 30 cps, adjustable.

RF ATTENUATOR RANGE: 50 db.

RF SENSITIVITY: M65 dbm for a one inch deflection on KRT.

IF GAIN CONTROL: 30 db.

PULSE WIDTH: 0.2 to 1.2 usec gated; 0.2 to 3 usec normal.

SWEEP SYNCHRONIZATION: At line frequency or subharmonics of line frequency.

IF BANDWIDTH: 60 porm 10 kc.

STABILITY AND JITTER: 1/32 inch at max sensitivity.

GATING TRIGGER: P10 to P50 v peak, 0.25 to 10 usec duration, repetition rates of 100 to 4000 cps, preceding first radar pulse by 1 usec min.

SYNCHROSCOPE

DEFLECTION SENSITIVITY: 1 v per 1/2 inch.

SWEEP SPEEDS: 5, 40, 150, 1000 or 3000 usec.

RF TRIGGER: 50 to 500 W peak, 0.2 to 10 usec duration, repetition rates of 100 to 4000 cps, average power not to exceed 1 W.

VIDEO TRIGGER: P10 to 50 v peak, 0.2 to 10 usec duration, repetition rates of 100 to 4000 cps.

VIDEO AMPLIFIER GAIN: 30 db.

VIDEO AMPLIFIER BANDWIDTH: 8 mc.

SIGNAL GENERATOR

POWER OUTPUT

RANGE (CALIBRATED): M5 to M100 dbm.

ACCURACY: Porm 3 db; porm 1 db from calibrated chart.

FREQUENCY MODULATION

FREQUENCY DEVIATION OF SWEEP: 0 to 20 mc min.

PHASE RANGE: 3 to 50 usec after triggering.

REPETITION RATE RANGE: 100 to 4000 cps.

TRIGGER AMPLIFIER GAIN: 1000.

MODULATION SWEEP GENERATOR

RF TRIGGER: 50 to 500 W peak, 0.2 to usec duration, repetition rates of 100 to 4000 cps, average power not to exceed 1 W.

VIDEO TRIGGER: P10 to P50 v peak. 0.25 to 10 usec duration, repetition rates of 100 to 4000 cps.

EXTERNAL MODULATION: 0.2 to 10 usec pulse width, repetition rates of 100 to 4000 cps, 40 v positive min.

POWER REQUIREMENTS: 210 W, 103.5 to 126.5 v, 50 to 800 cyc, single ph.

RELATION TO OTHER EQUIPMENT: None.

EQUIPMENT REQUIRED BUT NOT SUPPLIED: None.

MAJOR COMPONENTS

QTY	ITEM	STOCK NUMBERS	DIMENSIONS (INCHES)	WEIGHT (LBS)
1	Radar Test Set AN/UPM-44 includes:			
1	Radar Test Set TS-768/UPM-44			
1	Transit Case CY-1331/UPM-44			
1	Klystron 726C			
1	Klystron 726B			
1	Klystron 726A			
1	Klystron 2K29			
2	Cable Assy, Video CG-409/U		96 lg	
1	Cord Assy, Power CX-3277/U		96 lg	
1	Cable Assy, Output CG-92A/U		96 lg	
1	Antenna Assy AS-23/AP		1-1/4 x 2-1/4 x 4	0.19
1	Adapter UG-255/U			
3	Crystal, Rectifier 1N23B			
1	Thermistor and Resistor Assy			
5	Fuse, Cartridge			
3	Lamp, Heater Indicator			
3	Lamp, DBM Dial			
3	Lamp, Frequency-Meter Dial			
8	Gasket			
3	Wrench, Hex. Socket Screw			

REFERENCE DATA AND LITERATURE:

- NAVAER 16-30UPM44-501: Handbook Operation Instructions for Radar Test Sets AN/UPM-44, AN/UPM-44A.
- NAVAER 16-30UPM44-502: Handbook Service Instructions for Radar Test Sets AN/UPM-44, AN/UPM-44A.
- NAVAER 16-30UPM44-504: Illustrated Parts Breakdown for Radar Test Sets AN/UPM-44, AN/UPM-44A.

TUBE, CRYSTAL AND/OR SEMI-CONDUCTOR DATA:

TUBES: (3) 0A2 (1) 1Z2 (2) 2D21W (1) 2K29/726A, 726B, 726C (1) 3KP1 (1) 5R4WGA
 (1) 5651WA (1) 5687A (4) 5654/6AK5W (4) 5751 (5) 5814A (3) 6AH6 (2) 6AN5WA
 (2) 6AU6WA (1) 6X4W (1) 6AS6W (1) 6080WA (2) 12AT7WA

CRYSTALS: None used.

SEMI-CONDUCTORS: (1) 1N43 (2) 1N23B

AN/UPM-44 RADAR TEST SET

SHIPPING DATA

PKGS	VOLUME (CU FT)	WEIGHT (LBS)
1	10.2	

PROCUREMENT DATA

PROCURING SERVICE: USN
SPEC &/OR DWG:

DESIGN COG: USN, BuAer

CONTRACTOR	LOCATION	CONTRACT OR ORDER NO.	APPROX. UNIT COST
Sperry Gyroscope Co. Part no. 608501	Great Neck, N. Y.	NOas-54-6681	

9 April 1962
Cog Service:

FSN:

RADAR TEST SET AN/UPM-44A

Functional Class:

USA

USN

USAF

TYPE CLASS:

MANUFACTURER'S NAME/CODE NUMBER: Sperry Gyroscope Co., Div. of Sperry Rand Corp.

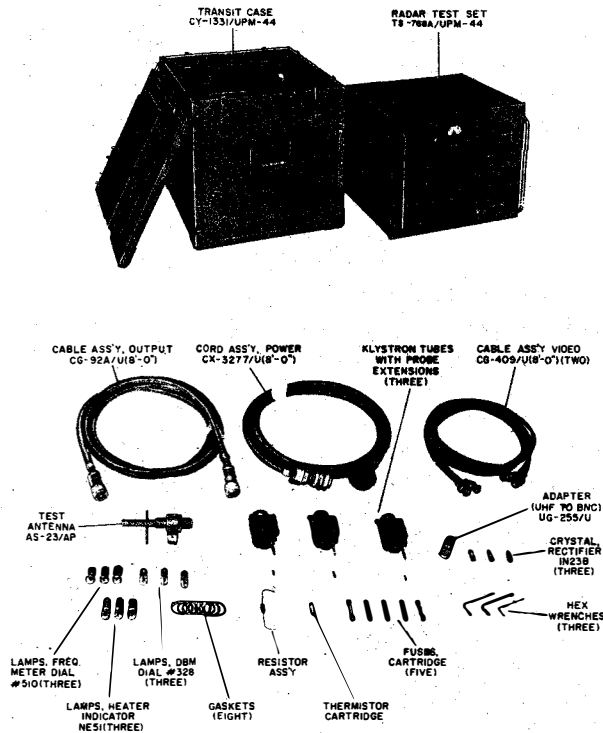

Radar Test Set AN/UPM-44A

FUNCTIONAL DESCRIPTION:

Radar Test Set AN/UPM-44A is a complete, portable test equipment designed for use with radar systems. It is used to perform the following functions: measurement of radar transmitter power and frequency; measurement of radar receiver bandwidth, sensitivity, recovery time, and local-oscillator frequency; tuning of radar local oscillators; performance testing and/or tuning of duplexers, AFC systems, rotating joints, etc; visual examination of the spectra of magnetrons, local oscillators, test sets and other equipment in its frequency range; investigation of magnetron pulling; and observation of video signals on synchroscope.

No field changes in effect at time of preparation (18 December 1961).

TECHNICAL CHARACTERISTICS:

POWER METER

FREQUENCY RANGE: 2700 to 3550 mc.

AN/UPM-44A RADAR TEST SET

POWER INPUT

RANGE: P5 to P30 dbm at input connector.

ACCURACY: Porm 3 db from dial; porm 1 db from correction chart.

FREQUENCY METER

FREQUENCY RANGE: 2700 to 3550 mc.

ABSOLUTE ACCURACY: Porm 3 mc, 2700 to 3550 mc at 25 deg C (77 deg F); porm 1 mc, 2700 to 3550 mc with correction charts.

RELATIVE ACCURACY: Porm 1 mc over any 60 mc interval.

SPECTRUM ANALYZER

TUNING RANGE: 2700 to 3550 mc.

SWEEP SPEEDS: 5 to 30 cps, adjustable.

R.F. ATTENUATOR RANGE: 50 db.

R.F. SENSITIVITY: M65 dbm for 1 in. deflection on KRT.

I.F. GAIN CONTROL: 30 db.

PULSE WIDTH: 0.2 to 1.2 usec gated; 0.2 to 3 usec normal.

SWEEP SYNCHRONIZATION: Subharmonics of line frequency.

I.F. BANDWIDTH: 60 porm 10 kc.

STABILITY AND JITTER: 1/32 in. at max sensitivity.

GATING TRIGGER: P10 to P50 v peak, 0.25 to 10 usec duration, repetition rates of 100 to 4000 cps preceding first radar pulse by 1 usec min.

SYNCHROSCOPE

DEFLECTION SENSITIVITY: 1 v per 1/2 in. min.

SWEEP SPEEDS: 5, 50, 150, 1000 or 3000 usec.

R.F. TRIGGER: 50 to 500 W peak, 0.2 to 10 usec duration, repetition rates of 100 to 4000 cps, average power not to exceed 1 W.

VIDEO TRIGGER: P10 to P50 v peak, 0.25 to 10 usec duration, repetition rates of 100 to 4000 cps.

VIDEO AMPLIFIER GAIN: 30 db.

VIDEO AMPLIFIER BANDWIDTH: 8 mc.

SIGNAL GENERATOR

POWER OUTPUT

RANGE (CALIBRATED): M5 to M100 dbm.

ACCURACY: Porm 3 db from dial; porm 1 db from correction chart.

FREQUENCY MODULATION

FREQUENCY DEVIATION OF SWEEP: 0 to 20 mc min.

PHASE RANGE: 3 to 50 usec after triggering.

REPETITION RATE RANGE: 100 to 4000 cps.

TRIGGER AMPLIFIER GAIN: 1000.

MODULATION SWEEP GENERATOR

R.F. TRIGGER: 50 to 500 W peak, 0.2 to 10 usec duration, repetition rates of 100 to 4000 cps, average power not to exceed 1 W.

VIDEO TRIGGER: P10 to P50 v peak, 0.25 to 10 usec duration, repetition rates of 100 to 4000 cps.

EXTERNAL MODULATION: 0.2 to 10 usec pulse width, repetition rates of 100 to 4000 cps, 40 v positive min.

PULSE MODULATION

PULSE WIDTH: 0.25, 0.50, 0.75, 1.0, 1.5 and 2.0 usec.

POWER REQUIREMENTS: 103.5 to 126.5 v, 50 to 800 cps, 210 W.

RELATION TO OTHER EQUIPMENT: None.

EQUIPMENT REQUIRED BUT NOT SUPPLIED: None.

MAJOR COMPONENTS

QTY	ITEM	STOCK NUMBERS	DIMENSIONS (INCHES)	WEIGHT (LBS)
1	Radar Test Set AN/UPM-44A includes:			
1	Test Set, Radar TS-768A/UPM-44		16-1/4 x 16-3/4 x 18-1/4	
1	Klystron 726C			
1	Klystron 726B			
1	Klystron 726A			
1	Klystron 2K29			
2	Cable Ass'y, Video CG-409/U		96 lg	
1	Cable Ass'y, Power CX-3277/U		96 lg	
1	Cable Ass'y, Output CG-92A/U		96 lg	
1	Antenna, Directive AS-23/AP			
1	Adapter (UHF to BNC) UG-255/U			
1	20 db Coaxial Pad			
3	Crystal, Rectifier 1N23B			
1	Thermistor and Resistor Component Ass'y			
5	Fuse, Cartridge			
3	Lamp, Heater Indicator			
3	Lamp, Ddm Dial			
3	Lamp, Frequency-Meter Dial			
8	Gasket			
3	Wrench, Hex Socket Screw			

REFERENCE DATA AND LITERATURE:

- NAVAER 16-30UPM44-501: Handbook of Operation Instructions for Radar Test Sets AN/UPM-44 and AN/UPM-44A.
- NAVAER 16-30UPM44-502: Handbook of Service Instructions for Radar Test Sets AN/UPM-44 and AN/UPM-44A.
- NAVAER 16-30UPM44-503: Handbook of Overhaul Instructions for Radar Test Sets AN/UPM-44 and AN/UPM-44A.
- NAVAER 16-30UPM44-504: Illustrated Parts Breakdown for Radar Test Sets AN/UPM-44 and AN/UPM-44A.

TUBE, CRYSTAL AND/OR SEMI-CONDUCTOR DATA:

TUBES: (3) 0A2 (1) 1Z2 (2) 2D21W (1) 3KP1 (1) 5R4WGA (3) 6AH6 (2) 6AN5
 (1) 6AS6W (2) 6AU6WA (1) 6X4W (1) 726A, 726B or 726C (2) 12AT7WA (1) 5651
 (4) 5654/6AK5 (1) 5687 (4) 5751 (5) 5814A (1) 6080

CRYSTALS: None used.

AN/UPM-44A RADAR TEST SET

SEMI-CONDUCTORS: (2) 1N23B (1) 1N43

SHIPPING DATA

PKGS	VOLUME (CU FT)	WEIGHT (LBS)
1		

PROCUREMENT DATA

PROCURING SERVICE: DESIGN COG: USN, BuWeps
SPEC &/OR DWG: MIL-T-18133 (AER)

CONTRACTOR	LOCATION	CONTRACT OR ORDER NO.	APPROX. UNIT COST
Sperry Gyroscope Co., Div. of Sperry Rand Corp. Part no. 616832	Great Neck, N. Y.	N0as-54-C.8-i	

9 April 1962
Cog Service:

FSN:

RADAR TEST SET AN/UPM-44B
Functional Class:

USA

USN

USAF

TYPE CLASS:

MANUFACTURER'S NAME/CODE NUMBER: Sperry Gyroscope Div. of Sperry Rand Corp.

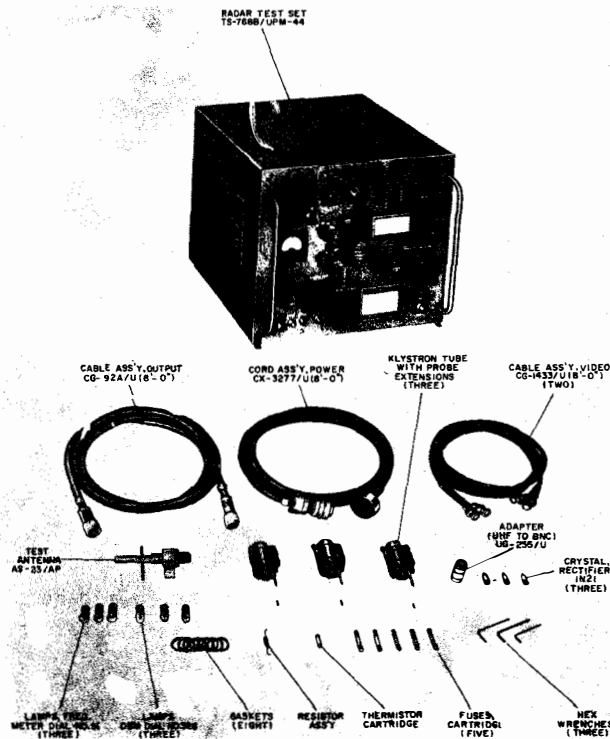

Radar Test Set AN/UPM-44B

FUNCTIONAL DESCRIPTION:

Radar Test Set AN/UPM-44B is a complete, portable test equipment designed for use with radar systems. It is used to perform the following functions: measurement of radar transmitter power and frequency; measurement of radar receiver bandwidth, sensitivity, recovery time, and local-oscillator frequency; tuning of radar local oscillators; performance testing and/or tuning of duplexers, AFC systems, rotating joints, etc; visual examination of the spectra of magnetrons, local oscillators, test sets and other equipment in its frequency range; investigation of magnetron pulling; and observation of video signals on synchroscope.

No field changes in effect at time of preparation (26 December 1961).

TECHNICAL CHARACTERISTICS:

POWER METER

FREQUENCY RANGE: 2,700 to 3,550 mc.

AN/UPM-44B RADAR TEST SET

POWER INPUT

RANGE: P5 to P30 dbm at input connector.

ACCURACY: Porm 2.0 db from dial at 25 deg C (77 deg F); porm 2.5 db from dial over range M20 deg C to 52 deg C (M4 deg to 125 deg F); porm 1.0 db from correction chart at 25 deg C (77 deg F); porm 1.5 db from correction chart over range M20 deg to 52 deg C (M4 deg to 125 deg F).

FREQUENCY METER

FREQUENCY RANGE: 2,700 to 3,550 mc.

ABSOLUTE ACCURACY (60% RELATIVE HUMIDITY): Porm 3 mc from dial at 25 deg C (77 deg F), porm 1 mc using panel calibration curve at 25 deg C (77 deg F); porm 6 mc from dial over range M20 deg to 52 deg C (M4 deg F to 125 deg F); porm 4 mc using panel calibration curve over range M20 deg to 52 deg C (M4 deg to 125 deg F), porm 2 mc using panel calibration curve and temperature correction chart over range M20 deg to 52 deg C (M4 deg to 125 deg F).

RELATIVE ACCURACY (60% RELATIVE HUMIDITY): Porm 1 mc over any 60 mc interval.

SPECTRUM ANALYZER

TUNING RANGE: 2,700 to 3,550 mc.

SWEEP FREQUENCY: 3 to 30 cps, adjustable.

R.F. ATTENUATOR RANGE: 100 db.

R.F. SENSITIVITY: M55 dbm for a 1 in. deflection on the CRT.

SWEEP SYNCHRONIZATION: At line frequency or subharmonics of line frequency.

I.F. BANDWIDTH: 60 kc max.

GATE WIDTH: 0.25 to 10 usec.

GATE DELAY: 1.0 to 4,000 usec.

JITTER: 1/32 in. at max sensitivity.

R.F. INPUT SIGNALS

POWER INPUT: 50 to 1,000 W (peak), average power not to exceed 1 W.

PULSE WIDTH: 0.20 to 3 usec.

REPETITION RATE: 100 to 4,000 pps.

MINIMUM PULSE SEPARATION (MULTIPULSED SIGNALS): 0.25 usec, trailing edge to leading edge.

MAXIMUM PULSE SEPARATION: 4,000 usec, first pulse to last pulse.

GATING TRIGGER: Porm 10 to porm 50 v, 0.2 to 10 usec duration, repetition rate of 100 to 4,000 pps (trigger must precede first pulse to be gated by a min of 1 usec).

SYNCHROSCOPE

DEFLECTION SENSITIVITY: 0.5 v per in.

SWEEP SPEEDS: 5, 20, 50, 250, and 4,000 usec.

VIDEO AMPLIFIER GAIN: 45 db.

VIDEO AMPLIFIER BANDWIDTH: 100 cps to 6 mc.

INPUT IMPEDANCE AT "SIGNAL" CONNECTOR: 50,000 ohms.

INPUT R.F. PULSES

FREQUENCY: 2,700 to 3,550 mc.

PULSE LENGTH: 0.20 to 10 usec.

REPETITION RATE: 100 to 4,000 pps.

POWER LEVEL: 50 to 1,000 W (peak), average power not to exceed 1 W.

INPUT VIDEO PULSES

PULSE LENGTH: 0.1 to 1,000 usec.

REPETITION RATE: 100 to 4,000 pps.

AMPLITUDE: 0.10 to 50 v.

R.F. TRIGGER: 50 to 1,000 W peak, 0.20 to 10 usec duration, repetition rate of 100 to 4,000 pps, avg power not to exceed 1 W.

VIDEO TRIGGER: Porm 10 to porm 50 v, 0.20 to 10 usec duration, repetition rate of 100 to 4,000 pps.

SIGNAL GENERATOR

POWER OUTPUT

RANGE (CALIBRATED): M5 to M100 dbm (serial no. 1 to 201); M60 to M90 dbm (serial no. 202 to 301).

ACCURACY: Porm 3 db from dial at 25 deg C (77 deg F), porm 1 db using correction chart at 25 deg C (77 deg F); porm 3.5 db from dial over range M20 deg to 52 deg C (M4 deg to 125 deg F), porm 1.5 db using correction chart over range M20 deg to 52 deg C (M4 deg F to 125 deg F).

FREQUENCY MODULATION

FREQUENCY EXCURSION: 0 to 5 mc per usec (min).

SIGNAL DELAY: 3 to 50 usec after triggering.

REPETITION RATE: 100 to 4,000 pps.

PULSE MODULATION

PULSE WIDTH: 0.25 to 10 usec, adjustable.

PULSE WIDTH ACCURACY: Porm 10% or porm 0.1 usec whichever is greater.

RISE TIME: 0.05 usec max.

DELAY: 1.0 to 4,000 usec after triggering.

EXTERNAL MODULATION: Any signal whose peak amplitude is less than 200 v.

R.F. TRIGGER: 50 to 1,000 W peak, 0.20 to 10 usec duration, repetition rate of 100 to 4,000 pps, avg power not to exceed 1 W.

POWER REQUIREMENTS: 103.5 to 126.5 v, 50 to 800 cyc, 210 W.

RELATION TO OTHER EQUIPMENT: None.

EQUIPMENT REQUIRED BUT NOT SUPPLIED: None.

MAJOR COMPONENTS

QTY	ITEM	STOCK NUMBERS	DIMENSIONS (INCHES)	WEIGHT (LBS)
1	Radar Test Set AN/UPM-44B includes:			
1	Test Set, Radar TS-768B/UPM-44			
1*	Transit Case CY-1331/UPM-44			
1	Klystron 726C (2700 to 2960 mc)			
1	Klystron 726B (2880 to 3175 mc)			
1	Klystron 726A (3175 to 3410 mc)			
1	Klystron 2K29 (3400 to 3900 mc)			
1**+	Accessories Case CY-1873/UPM-44A			
1**+	Air Transit Rack MT-1610/UPM-44A			
2	Cable Ass'y, Video CG-1433/U		96 lg	
1	Cord Ass'y, Power CX-3277/U		96 lg	
1	Cable Ass'y, R.F. CG-92A/U		96 lg	
1	Antenna, Directive AS-23/AP			
1	Adapter (UHF to BNC) UG-255/U			
3+	Crystal, Rectifier 1N21			
1+	Thermistor and Resistor Component Ass'y			

AN/UPM-44B RADAR TEST SET

QTY	ITEM	STOCK NUMBERS	DIMENSIONS (INCHES)	WEIGHT (LBS)
5+	Fuse, Cartridge			
3+	Lamp, Ddm Dial			
3+	Lamp, Frequency-Meter Dial			
8+	Gasket			
1	Wrench (0.050 in., L-type, 1-3/4 in.)			
1	Wrench (0.062 in., L-type, 1-3/4 in.)			
1	Wrench (0.078 in., L-type 1-7/8 in.)			

* This item supplied under contract N383-53701A and N383-60764A.

** These items are not supplied except on special order.

+ These items are not supplied under contract N383-53701A and N383-60764A.

REFERENCE DATA AND LITERATURE:

- NAVWEPS 16-30UPM44-505: Handbook of Operation Instructions for Radar Test Sets AN/UPM-44B and AN/UPM-44C.
- NAVWEPS 16-30UPM44-506: Handbook of Service Instructions for Radar Test Sets AN/UPM-44B and AN/UPM-44C.
- NAVWEPS 16-30UPM44-507: Handbook of Overhaul Instructions for Radar Test Sets AN/UPM-44B and AN/UPM-44C.
- NAVWEPS 16-30UPM44-508: Illustrated Parts Breakdown for Radar Test Sets AN/UPM-44B and AN/UPM-44C.
- TO 33A1-3-111-1: Handbook of Operation Instructions for Radar Test Sets AN/UPM-44B and AN/UPM-44C.
- TO 33A1-3-111-2: Handbook of Service Instructions for Radar Test Sets AN/UPM-44B and AN/UPM-44C.
- TO 33A1-3-111-3: Handbook of Overhaul Instructions for Radar Test Sets AN/UPM-44B and AN/UPM-44C.
- TO 33A1-3-111-4: Illustrated Parts Breakdown for Radar Test Sets AN/UPM-44B and AN/UPM-44C.

TUBE, CRYSTAL AND/OR SEMI-CONDUCTOR DATA:

TUBES: (3) 0A2WA (1) 1Z2 (1) 3KP1 (1) 5R4WGA (5) 6AH6 (1) 6D4 (1) 6AU6WA
(1) 6X4W (1) 726C (1) 726B (1) 726A (1) 2K29 (1) 12AT7WA (1) 5639
(1) 5651 (3) 5654 (2) 5687 (1) 5725/6AS6W (3) 5751 (5) 5814A (1) 6080WA
(4) 6111

CRYSTALS: None used.

SEMI-CONDUCTORS: (2) 1N21 (5) 1N121 (2) 1ES2

SHIPPING DATA

PKGS	VOLUME (CU FT)	WEIGHT (LBS)
------	----------------	--------------

PROCUREMENT DATA

PROCURING SERVICE:	DESIGN COG: USN, BuWeps
SPEC &/OR DWG: MIL-T-18133B(AER)	

CONTRACTOR	LOCATION	CONTRACT OR ORDER NO.	APPROX. UNIT COST
Sperry Gyroscope Div. of Sperry Rand Corp. Part no. 617004	Great Neck, N. Y.	N383-53 701A N383-60764A	

25 May 1962
Cog Service: USN

FSN:

RADAR TEST SET AN/UPM-44C
Functional Class: 10.1

USA

USN

USAF

TYPE CLASS:

Used by

Std

MANUFACTURER'S NAME/CODE NUMBER: Sperry Gyroscope Div. of Sperry Rand Corp.

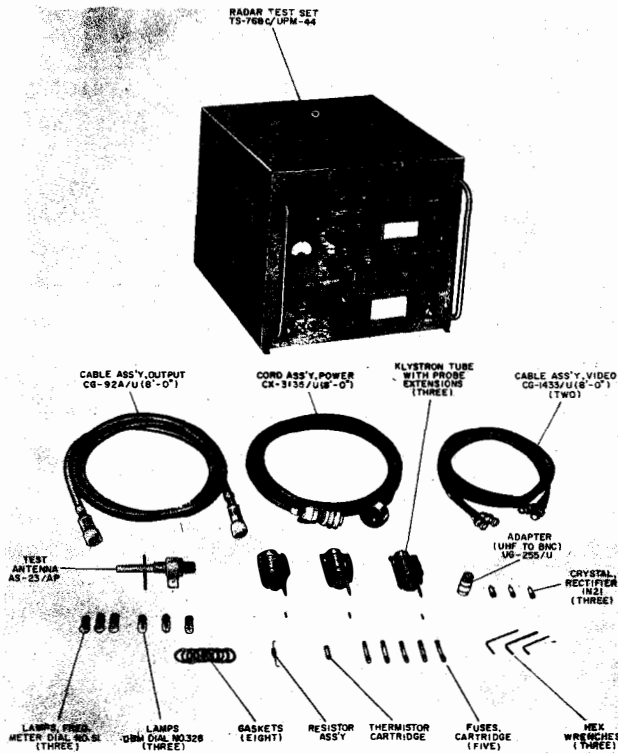

Radar Test Set AN/UPM-44C

FUNCTIONAL DESCRIPTION:

Radar Test Set AN/UPM-44C is a complete, portable test equipment designed for use with radar systems. It is used to perform the following functions: measurement of radar transmitter power and frequency; measurement of radar receiver bandwidth, sensitivity, recovery time, and local-oscillator frequency; tuning of radar local oscillators; performance testing and/or tuning of duplexers, AFC systems, rotating joints, etc; visual examination of the spectra of magnetrons, local oscillators, test sets and other equipment in its frequency range; investigation of magnetron pulling; and observation of video signals on synchroscope.

No field changes in effect at time of preparation (26 December 1961).

TECHNICAL CHARACTERISTICS:

POWER METER

FREQUENCY RANGE: 2,700 to 3,550 mc.

AN/UPM-44C RADAR TEST SET

POWER INPUT

RANGE: P5 to P30 dbm at input connector.

ACCURACY: Porm 2.0 db from dial at 25 deg C (77 deg F); porm 2.5 db from dial over range M20 deg C to 52 deg C (M4 deg to 125 deg F); porm 1.0 db from correction chart at 25 deg C (77 deg F); porm 1.5 db from correction chart over range M20 deg to 52 deg C (M4 deg to 125 deg F).

FREQUENCY METER

FREQUENCY RANGE: 2,700 to 3,550 mc.

ABSOLUTE ACCURACY (60% RELATIVE HUMIDITY): Porm 1.5 mc from dial at 25 deg C (77 deg F); porm 3 mc from dial over range M20 deg to 52 deg C (M4 deg to 125 deg F).

RELATIVE ACCURACY (60% RELATIVE HUMIDITY): Porm 1 mc over any 60 mc interval.

SPECTRUM ANALYZER

TUNING RANGE: 2,700 to 3,550 mc.

SWEEP FREQUENCY: 3 to 30 cps, adjustable.

R. F. ATTENUATOR RANGE: 100 db.

R. F. SENSITIVITY: M55 dbm for a 1 in. deflection on the CRT.

SWEEP SYNCHRONIZATION: At line frequency or subharmonics of line frequency.

I. F. BANDWIDTH: 60 kc max.

GATE WIDTH: 0.25 to 10 usec.

GATE DELAY: 1.0 to 4,000 usec.

JITTER: 1/32 in. at max sensitivity.

R. F. INPUT SIGNALS

POWER INPUT: 50 to 1,000 W (peak), average power not to exceed 1 W.

PULSE WIDTH: 0.20 to 3 usec.

REPETITION RATE: 100 to 4,000 pps.

MINIMUM PULSE SEPARATION (MULTIPULSED SIGNALS): 0.25 usec, trailing edge to leading edge.

MAXIMUM PULSE SEPARATION: 4,000 usec, first pulse to last pulse.

GATING TRIGGER: Porm 10 to Porm 50 v, 0.2 to 10 usec duration, repetition rate of 100 to 4,000 pps (trigger must precede first pulse to be gated by a minimum of 1 usec).

SYNCHROSCOPE

DEFLECTION SENSITIVITY: 0.5 v per in.

SWEEP SPEEDS: 5, 20, 50, 250, and 4,000 usec.

VIDEO AMPLIFIER GAIN: 45 db.

VIDEO AMPLIFIER BANDWIDTH: 100 cps to 6 mc.

INPUT IMPEDANCE AT "SIGNAL" CONNECTOR: 50,000 ohms.

INPUT R. F. PULSES

FREQUENCY: 2700 to 3550 mc.

PULSE LENGTH: 0.20 to 10 usec.

REPETITION RATE: 100 to 4,000 pps.

POWER LEVEL: 50 to 1,000 W (peak), avg power not to exceed 1 W.

INPUT VIDEO PULSES

PULSE LENGTH: 0.1 to 1,000 usec.

REPETITION RATE: 100 to 4,000 pps.

AMPLITUDE: 0.10 to 50 v.

R. F. TRIGGER: 50 to 1,000 W peak, 0.20 to 10 usec duration, repetition rate of 100 to 4,000 pps, avg power not to exceed 1 W.

VIDEO TRIGGER: Porm 10 to porm 50 v, 0.20 to 10 usec duration, repetition rate of 100 to 4,000 pps.

INTERNALLY GENERATED TRIGGER

RADAR TEST SET AN/UPM-44C

REPETITION RATE: 100 to 4,000 pps.
OUTPUT TRIGGER AMPLITUDE: 15 v pos.

SIGNAL GENERATOR**POWER OUTPUT**

RANGE (CALIBRATED): M60 to M90 dbm.
ACCURACY: Porm 2 db from dial at 25 deg C (77 deg F), porm 1 db using correction chart at 25 deg C (77 deg F); porm 2.5 db from dial over range M20 deg to 52 deg C (M4 deg to 125 deg F); porm 1.5 db using correction chart over range M20 deg to 52 deg C (M4 deg to 125 deg F).

FREQUENCY MODULATION

FREQUENCY EXCURSION: 0 to 5 mc per usec (min).
SIGNAL DELAY: 3 to 50 usec after triggering.
REPETITION RATE: 100 to 4,000 pps.

PULSE MODULATION

PULSE WIDTH: 0.25 to 10 usec, adjustable.
PULSE WIDTH ACCURACY: Porm 10% or porm 0.1 usec whichever is greater.
RISE TIME: 0.05 usec max.
DELAY: 1.0 to 4,000 usec after triggering.
EXTERNAL MODULATION: Any signal whose peak amplitude is less than 200 v.
R. F. TRIGGER: 50 to 1,000 W peak, 0.20 to 10 usec duration, repetition rate of 100 to 4,000 pps, average power not to exceed 1 W.
VIDEO TRIGGER: Porm 10 to porm 50 v, 0.20 to 10 usec duration, repetition rate of 100 to 4,000 pps.

INTERNALLY GENERATED TRIGGER

REPETITION RATE: 100 to 4,000 pps.
OUTPUT TRIGGER AMPLITUDE: 15 v pos.

POWER REQUIREMENTS: 103.5 to 126.5 v, 50 to 800 cyc, 210 W.

RELATION TO OTHER EQUIPMENT: None.

EQUIPMENT REQUIRED BUT NOT SUPPLIED: None.

MAJOR COMPONENTS

QTY	ITEM	STOCK NUMBERS	DIMENSIONS (INCHES)	WEIGHT (LBS)
1	Radar Test Set AN/UPM-44C Includes:			
1	Test Set, Radar TS-768C/UPM-44			
1*	Transit Case CY-1331/UPM-44			
1	Klystron 726C (2700 to 2960 mc)			
1	Klystron 726B (2880 to 3175 mc)			
1	Klystron 726A (3175 to 3410 mc)			
1	Klystron 2K29 (3400 to 3900 mc)			
1**+	Accessories Case Cy-1873/UPM-44A			
1**+	Air Transit Rack MT-1610/UPM-44A			
2	Cable Assy, Video CG-1433/U		96 1g	
1	Cord Assy, Power CX-3135/U		96 1g	
1	Cable Assy, R. F. CG-92A/U		96 1g	
1	Antenna, Directive AS-23/AP			

AN/UPM-44C RADAR TEST SET

QTY	ITEM	STOCK NUMBERS	DIMENSIONS (INCHES)	WEIGHT (LBS)
1	Adapter (UHF to BNC) UG-255/U			
3+	Crystal, Rectifier 1N21			
1+	Thermistor and Resistor Component Assy			
5+	Fuse, Cartridge			
3+	Lamp, Ddm Dial			
3+	Lamp, Frequency-Meter Dial			
8+	Gasket			
1	Wrench (0.050 in., L-type, 1-3/4 in.)			
1	Wrench (0.062 in., L-type, 1-3/4 in.)			
1	Wrench (0.078 in., L-type, 1-7/8 in.)			

*This item supplied under contract N383-53701A and N383-60764A.

**These items are not supplied except on special order.

+These items are not supplied under contract N383-53701A and N383-60764A.

REFERENCE DATA AND LITERATURE:

NAVWEPS 16-30UPM44-505: Handbook of Operation Instructions for Radar Test Sets AN/UPM-44B and AN/UPM-44C.

NAVWEPS 16-30UPM44-506: Handbook of Service Instructions for Radar Test Sets AN/UPM-44B and AN/UPM-44C.

NAVWEPS 16-30UPM44-507: Handbook of Overhaul Instructions for Radar Test Sets AN/UPM-44B and AN/UPM-44C.

NAVWEPS 16-30UPM44-508: Illustrated Parts Breakdown for Radar Test Sets AN/UPM-44B and AN/UPM-44C.

TO 33A1-3-111-1: Handbook of Operation Instructions for Radar Test Sets AN/UPM-44B and AN/UPM-44C.

TO 33A1-3-111-2: Handbook of Service Instructions for Radar Test Sets AN/UPM-44B and AN/UPM-44C.

TO 33A1-3-111-3: Handbook of Overhaul Instructions for Radar Test Sets AN/UPM-44B and AN/UPM-44C.

TO 33A1-3-111-4: Illustrated Parts Breakdown for Radar Test Sets AN/UPM-44B and AN/UPM-44C.

TUBE, CRYSTAL AND/OR SEMI-CONDUCTOR DATA:

TUBES: (3) 0A2WA (1) 1Z2 (1) 3KP1 (1) 5R4WGA (5) 6AH6 (1) 6D4 (1) 6AU6WA
(1) 6X4W (1) 726C (1) 726B (1) 726A (1) 2K29 (1) 12AT7WA (1) 5639
(1) 5651 (3) 5654 (2) 5687 (1) 5725/6AS6W (3) 5751 (5) 5814A (1) 6080WA
(4) 6111

CRYSTALS: None used.

SEMI-CONDUCTORS: (2) 1N21 (5) 1N127 (2) 1ES2

4.10 AN/UPM-44C: 4

SHIPPING DATA

PKGS VOLUME (CU FT) WEIGHT (LBS)

PROCUREMENT DATA

PROCURING SERVICE: USN DESIGN COG: USN, BuWeps
SPEC &/OR DWG:

CONTRACTOR	LOCATION	CONTRACT OR ORDER NO.	APPROX. UNIT COST
Sperry Gyroscope Div of Sperry Rand Corp. Part no. 2375279	Great Neck, N. Y.	N383-53701A N383-60764A	
Polarad Electronics Corp. Part no. D12894	Long Island City, N. Y.	Nom-70980	

April 1958

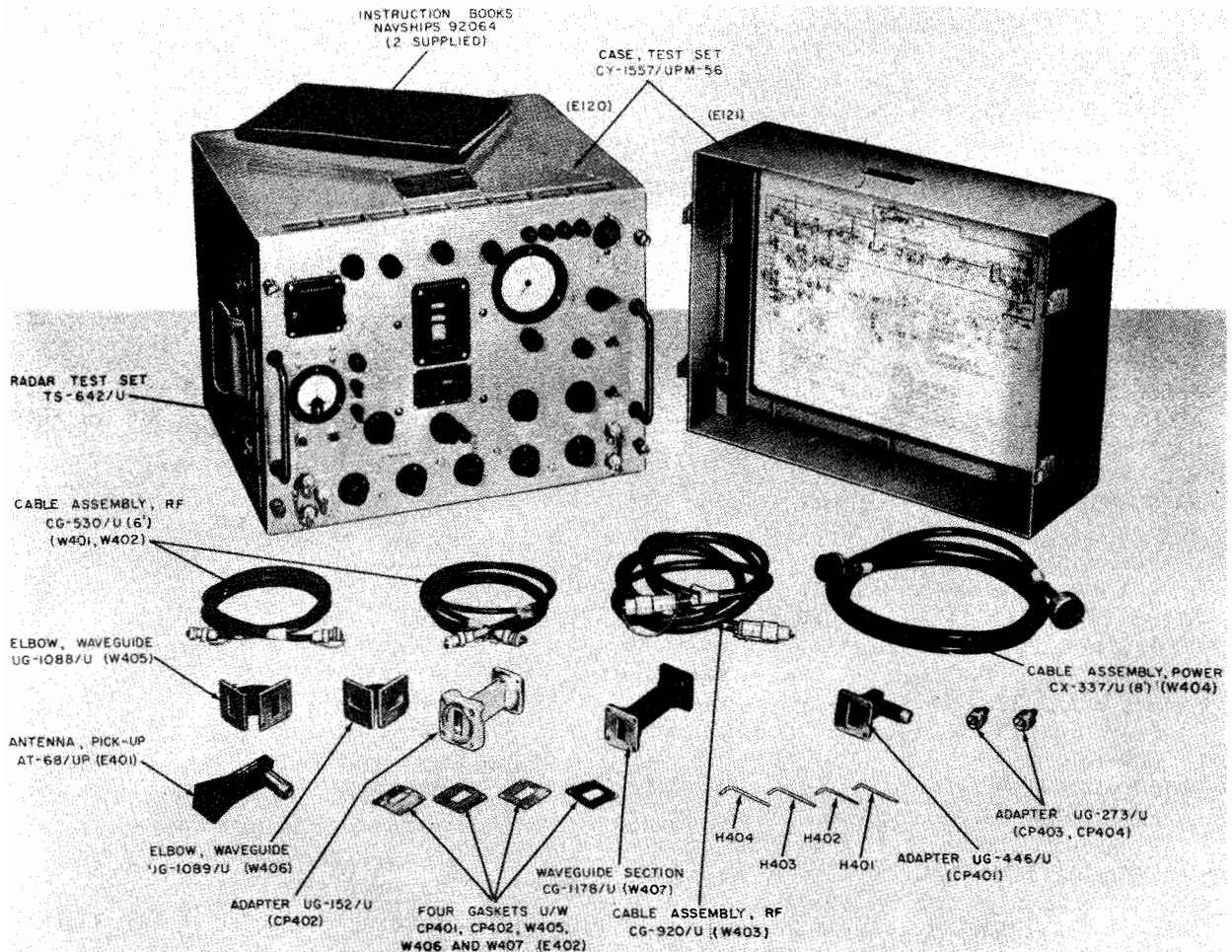
TEST SET, RADAR**AN/UPM-56***Test Set, Radar AN/UPM-56***FUNCTIONAL DESCRIPTION**

The AN/UPM-56 is a portable precision microwave signal generator, power meter, and frequency meter for testing and adjusting radar, beacon, and associated equipments operating in the frequency bands of 8500 to 9600 mc. It can be used as a continuous wave (CW), frequency modulated (FM), square wave modulated (SW), or pulse modulated signal generator.

The pulse modulation is obtained from a pulse generator within the test set. Pulsed RF signals are used for receiver tuning and measurements of receiver sensitivity, radar range, TR recovery time, etc.

Frequency modulation is obtained from a sawtooth sweep generator within the test set.

The FM output is used with an oscilloscope for receiver frequency and bandwidth measurements.

The continuous wave output is used for receiver sensitivity and frequency measurements.

A square wave output, with a repetition rate of about 1000 pps, is used for impedance, standing wave, and similar measurements with a slotted line.

No field changes in effect at time of preparation (6 March 1958).

RELATION TO OTHER EQUIPMENT

Equipment Required but not Supplied:
While most of the tests can be performed with

Test-Combination and Group

AN/UPM-56**TEST SET, RADAR**

April 1958

the radar indicator, some tests require a synchroscope or oscilloscope (with "A" scan such as Oscilloscope AN/USM-24, or AN/USM-32 or a unit of the TS-34/AP Series.

ELECTRICAL AND MECHANICAL CHARACTERISTICS**POWER METER**

FREQUENCY RANGE: 8500 to 9600 mc.

POWER RANGE: + 1 to + 30 dbm.

ACCURACY: $\pm 1\frac{1}{2}$ db.**FREQUENCY METER**

FREQUENCY RANGE: 8500 to 9600 mc.

ACCURACY: ± 1 mc.CALIBRATION POINT: 9310 mc $\pm 1/2$ mc.**SIGNAL GENERATOR**

FREQUENCY RANGE: 8500 to 9600 mc.

POWER: 0 to -105-dbm (average) in three steps; -1 to -36 dbm, -36 to -71 dbm, -71 dbm to 105 dbm.

STABILITY: Less than one mc frequency drift in 60 minute interval.

CW OPERATION: The test set can be set to any condition within the above specified limits of frequency, range and power.

PULSE MODULATIONFIXED DURATION: 1.0 and 2.35 ± 0.1 usec.

VARIABLE DURATION: 0.2 to 10 usec in two ranges, 0.2 to 1.0 usec, 1.0 to 10 usec with indicated accuracy of 10%.

REPETITION RATE: 100 to 300000 in four ranges, 100 to 1000, 1000 to 10000, 10000 to 100000 and high of 100000 to 300000 pps approx at an indicated accuracy of 10%.

SQUARE WAVE OUTPUT: 1000 pps $\pm 20\%$.

RISE TIME: 0.1 usec.

DECAY TIME: 0.1 usec.

DELAY: Pulse modulation continuously variable in four ranges, less than 1 usec (from TRIG to RF (OUT) 1 to 10 usec, 10 to 100 usec and 100 to 1000 usec with an indicated accuracy of approx 10%.

PULSE MONITOR: A connector is provided to view video pulses, these pulses are within 0.1 usec of RF pulse duration.

FREQUENCY MODULATION

SWEEP RATE: 0.02 to over 25 mc/usec

continuously variable.

DELAY: Less than 1 usec from RF or Video trigger.

FREQUENCY EXCURSION: At least 25 mc.

SWEEPS PER SEC: 100 to 1000, 1000 to 10000, 10000 to 100000 and about 300000 sweeps per sec.

INPUT TRIGGER DATA

TYPE: Video or RF.

DURATION: 1 usec min.

RISE TIME: 2 usec max.

PEAK POWER: 10 v or 5 W min.

PULSE RECURRENCE FREQ: 100 to 50000 pps.

INPUT IMPEDANCE

R.F: 52 ohms.

VIDEO: 75 ohms.

TRIGGER GENERATOR

POLARITY: Pos or neg.

DURATION: 0.5 to 5 usec.

RISE TIME: 0.1 usec max.

DECAY TIME: 0.1 usec max.

PEAK VOLTS: 25 to 50 v at 75 ohms.

PULSE REPETITION RATE: 100 to 50000 pps.

RF PULSE ENVELOPE: This connector is for coupling an oscilloscope to view envelopes of RF pulses applied to the test set.

POWER SOURCE REQUIRED: 115 v $\pm 10\%$, 50 to 1000 cps, single ph, 350 W (50 W stand-by).**MANUFACTURER'S OR CONTRACTOR'S DATA**

General Communication Co, Boston, Mass.

Contract NObsr-43172, dated 28 January 1949.

Contract NObsr-52261, dated 19 February 1951.

TUBE AND/OR CRYSTAL COMPLEMENT

(3) OA2WA

(2) 6AX4GT

(2) 6AH6

(1) 2K25

(1) 5687WA

(1) 5814A

(9) 12AT7WA

(4) 6X4WA

(2) 6AN5WA

(3) 6AU6WA

UNCLASSIFIED

Test-Combination and Group

April 1958

TEST SET, RADAR**AN/UPM-56**

(8) 6005/6AQ5W
 Total Tubes: (36)
 (1) 1N23B (12) 1N69
 Total Crystals: (13)

TYPE CLASSIFICATION
 DESIGN COGNIZANCE BUSHIPS
 PROCUREMENT COGNIZANCE
 STOCK NO.
 R.D.B. IDENT. NO.

REFERENCE DATA AND LITERATURE

NAVSHIPS 92064, Technical Manual for Test
 Set AN/UPM-56.

SHIPPING DATA

NUMBER OF BOXES	CONTENTS AND IDENTIFICATION	VOLUME (Cu.Ft.)	OVERALL DIMENSIONS (inches)	WEIGHT PACKED (lbs.)
1	Radar Test Set AN/UPM-56	8.8	19-1/2 X 27-1/4 X 28-1/2	180

EQUIPMENT SUPPLIED DATA

QUANTITY PER EQUIPT	NAME AND NOMENCLATURE	OVERALL DIMENSIONS (inches)	WEIGHT (lbs.)
1	Radar Test Set AN/UPM-56 incl	14-11/16 X 20-13/16 X 21-29/32	120
1	Test Set, Radar TS-642/U		78
1	Case, Test Set CY-1557/UPM-56	14-11/16 X 20-13/16 X 21-29/32	35.5
1	Set of Accessories incl		
	(2) Cable Assemblies, RF CG-530/U	72	1
	(1) Cord CG-92A/U	72	0.75
	(1) Cord	96	0.75
	(1) Waveguide Assembly CG-1178/U	1-5/8 X 1-5/8 X 4	0.5
	(1) Elbow, waveguide UG-1088/U	1-5/8 X 2-1/16 X 2-1/16	0.25
	(1) Elbow, waveguide UG-1089/U	1-5/8 X 2-1/16 X 2-1/16	0.25
	(1) Pick-up Antenna AT-68/UP	1-3/4 X 2-1/4 X 4-1/2	0.3
	(1) Adapter Connector UG-446/U	1-5/8 X 1.930 X 2-5/8	0.1
	(2) Adapter UG-152/U	1-5/8 X 1-5/8 X 3.410	0.8
	(4) Gasket, waveguide Flange	1-5/8 X 1-5/8 X 0.003	
	(2) Technical Manuals NAVSHIPS 92064	1/2 X 8-1/2 X 11	1

UNCLASSIFIED

4.10 AN/UPM-56: 3

12 February 1963

Cog Service: USN FSN:

RADAR TEST SET AN/UPM-6(XN-21)

Functional Class: 10.1

USA

USN

USAF

TYPE CLASS:

Used by

MANUFACTURER'S NAME/CODE NUMBER: Hazeltine Electronics Corporation, (27876).

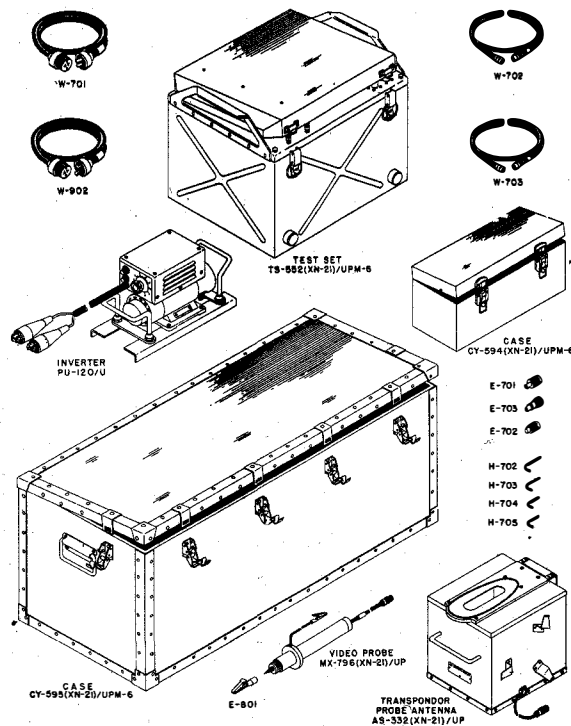

Radar Test Set AN/UPM-6(XN-21)

FUNCTIONAL DESCRIPTION:

Radar Test Set AN/UPM-6(XN-21) is a portable test equipment operating in the .950 to 115.0 mc frequency band, designed principally to perform operating and non-operating field test and rough accuracy checks on the operating equipments of the Mark 5 IFF systems.

No field changes in effect at time of preparation (27 December 1962).

TECHNICAL CHARACTERISTICS:

TEST SET TS-552(XN-21)/UPM-6

CODER

PULSE RECURRENCE FREQUENCY: 1000 pps porm 20%.

RISE TIME: Not to exceed 0.2 usec.

DECAY TIME: Not to exceed 0.4 usec.

AN/UPM-6(XN-21) RADAR TEST SET

DECODER

DURATION: 0.7 and 1.2 usec.

DEMODULATOR

FREQUENCY RANGE: 950 to 1150 mc.

VIDEO OUTPUT: Not greater than 30 v peak.

ATTENUATION: 13 db.

WAVEMETER

FREQUENCY RANGE: 925 to 1210 mc.

ACCURACY: Porm 0.7 mc.

SENSITIVITY: At least 25% deflection on peak voltmeter.

POWER REQUIREMENTS: 115 v porm 15%, 47 to 2400 cyc, single ph; or 20 to 30 v dc.

RELATION TO OTHER EQUIPMENT: None.

EQUIPMENT REQUIRED BUT NOT SUPPLIED: None.

MAJOR COMPONENTS

QTY	ITEM	STOCK NUMBERS	DIMENSIONS (INCHES)	WEIGHT (LBS)
1	Radar Test Set AN/UPM-6(XN-21) includes:			
1	Test Set TS-552(XN-21)/UPM-6		13-1/4 x 13-3/4 x 17	62.4
1	Video Probe MX-796(XN-1)/UP		2-3/16 dia x 69-3/8	0.8
1	Inverter PU-120/U		5-5/16 x 7-3/8 x 12-1/4	10.1
1	Case CY-595(XN-21)/UPM-6		15-1/2 x 16-3/8 x 38	32.7
1	Transponder Probe Antenna AS-332(XN-21)/UP		9-1/8 x 9-1/8 x 11-1/2	4.8
1	Case CY-594(XN-21)/UPM-6		6 x 6-7/16 x 13-13/16	3.3
1	Adapter UG-309/U		7/8 dia x 1-1/2	0.1
1	Adapter UG-273/U		23/32 dia x 1-1/4	0.1
1	Adapter UG-201/U		3/4 dia x 1-9/16	0.1
1	Wrench, Allen-Head no. 4		3/64 x 35/64 x 1-51/64	0.1
1	Wrench, Allen-Head no. 6		1/16 x 9/16 x 1-13/16	0.1
1	Wrench, Allen-Head no. 8		5/64 x 11/16 x 1-61/64	0.1
1	Wrench, Allen-Head no. 10		3/32 x 3/4 x 2-3/32	0.1
1	Cable, R.F.		1/2 dia x 4-1/2	0.1
1	Cable, Assy, Power		1-1/4 dia x 120	0.8
1	Cable, Output Inverter		1-1/4 dia x 600	2.8
1	Cable, Video		1/2 dia x 300	1.0
1	Cable, R.F.		1/2 dia x 120	0.4
5	Wavemeter Calibration Chart		0.030 x 8.5 x 11	
2	Demodulator Power Calibration Chart		0.030 x 8.5 x 11	
1	R.F. Signal Generator Calibra- tion and Demodulator Fre- quency Correction Chart		0.030 x 8.5 x 11	
1	DB to Watts Conversion Chart		0.030 x 8.5 x 11	

4.10 AN/UPM-6(XN-21): 2

RADAR TEST SET AN/UPM-6(XN-21)

QTY	ITEM	STOCK NUMBERS	DIMENSIONS (INCHES)	WEIGHT (LBS)
13	Card, R.F. Setting		0.030 x 1.25 x 4.625	
1	Alligator Clip		1/2 x 11/16 x 2-7/16	0.1
1	Chart, Content Index		0.020 x 2.531 x 6.187	

REFERENCE DATA AND LITERATURE:

NAVSHIPS 900,951: Technical Manual for Radar Test Set AN/UPM-6(XN-21).

TUBE, CRYSTAL AND/OR SEMI-CONDUCTOR DATA:

TUBES: (1) 0B2 (2) 2B22 (1) 5Y3GT/G (13) 6AK5 (6) 6AL5 (2) 6AS6 (10) 6C4
(1) 6L4 (1) 6X5GT/G

CRYSTALS: None used.

SEMI-CONDUCTORS: (2) 1N25

SHIPPING DATA

PKGS	VOLUME (CU FT)	WEIGHT (LBS)
1	10.2	139

PROCUREMENT DATA

PROCURING SERVICE: USN

DESIGN COG: USN, BuShips

SPEC &/OR DWG:

CONTRACTOR	LOCATION	CONTRACT OR ORDER NO.	APPROX. UNIT COST
Hazeltine Electronics Corporation	Little Neck, L. I., N. Y.	NXsr-79980	

RADAR TEST SET

AN/UPM-6,-6A,-6B

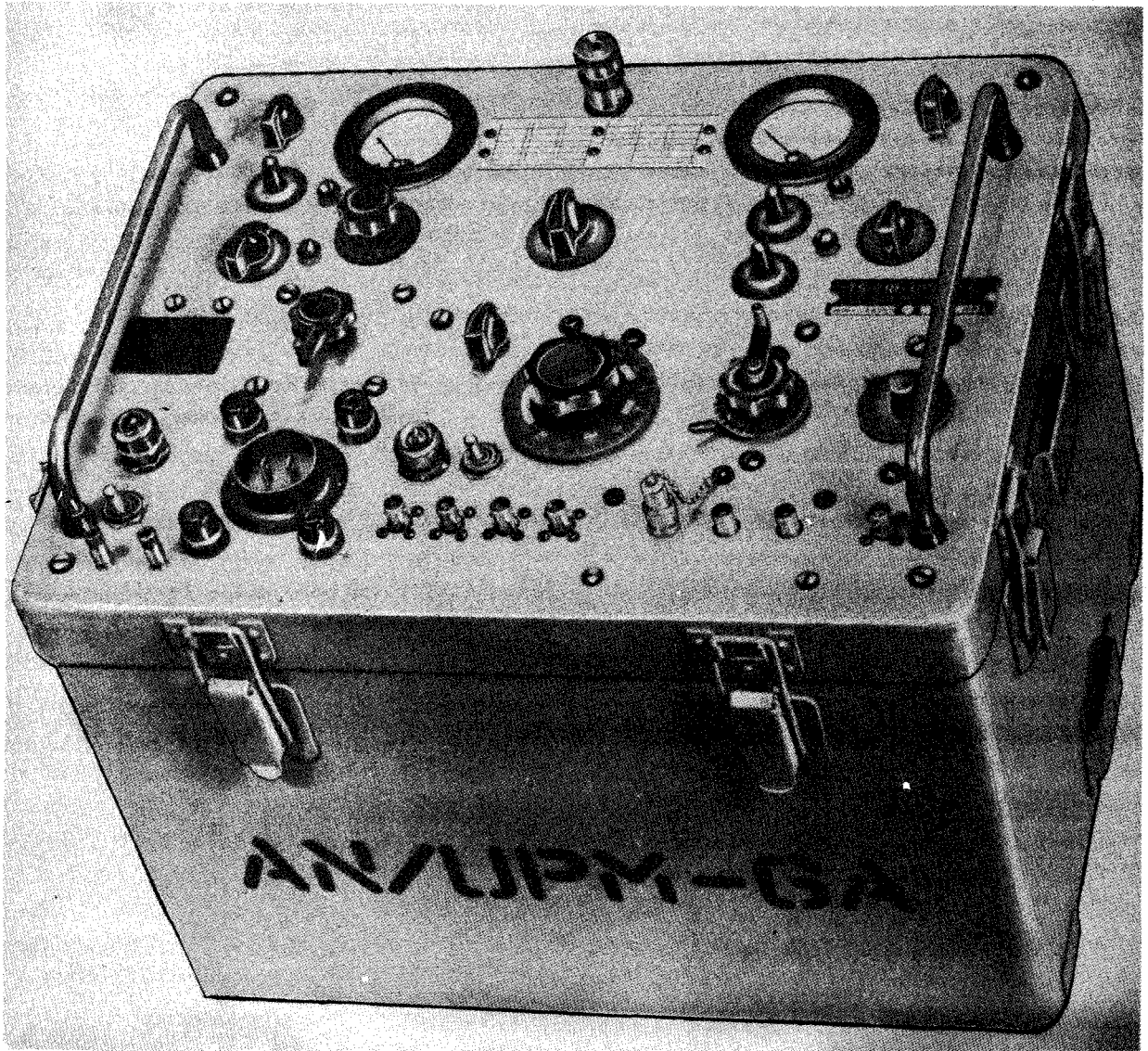

Radar Test Set AN/UPM-6A

FUNCTIONAL DESCRIPTION

The AN/UPM-6, AN/UPM-6A, and AN/UPM-6B are portable equipments designed to perform maintenance tests and to permit making measurements of frequency, power, and sensitivity on pulse type equipments. They are equally adaptable for use in preflight tests of airborne IFF equipments, or for tests on ground

components of operating systems and may be made to simulate either a transponder or an interrogator. In making tests on interrogators, the test set receives paired-pulse interrogations, gives evidence of correctness of the pulse spacing, and provides a reply to the interrogating receiver. In making tests on transponders, the test set interrogates the transponder and receives the transponder reply.

April 1958

Test-Combination and Group

AN/UPM-6,-6A,-6B**RADAR TEST SET**

The AN/UPM-6A and AN/UPM-6B are practically identical and are improvements on the AN/UPM-6 in that they have provisions for delivering a demodulated RF envelope for observation on an external oscilloscope, synchronizing the test set from an external source, and for synchronizing external test equipment.

Field change 2 to AN/UPM-6B extends its testing facilities to include tests of Selective Identification Feature (SIF) coder and decoder systems. In these tests, the modified AN/UPM-6B acts as an auxiliary test equipment to Coder-Decoder Group AN/UPA-39.

Data on this sheet reflects the following Field Changes: FC-1 (AN/UPM-6A, -6B), FC-2 (AN/UPM-6B) (28 May 1958).

ELECTRICAL AND MECHANICAL CHARACTERISTICS**WAVEMETER DATA****FREQUENCY RANGE**

AN/UPM-6: 925 to 1210 mc.

AN/UPM-6A,-6B: 960 to 1150 mc.

ACCURACY: ± 0.7 mc.**SIGNAL GENERATOR DATA****FREQUENCY RANGE**

AN/UPM-6: 925 to 1125 mc.

AN/UPM-6A,-6B: 980 to 1125 mc.

CODER OUTPUT**AN/UPM-6****MODE SELECTOR POSITION**

IFF

PI

FLI

SINGLE PULSE (NARROW)

SINGLE PULSE (WIDE)

**USEC
PULSE DURATION**

0.7 to 1.2

0.7 to 1.2

0.7 to 1.2

0.9 to 1.3

2.25 to 2.75

**USEC
PULSE SPACING**

2.8 to 3.2

4.8 to 5.2

7.8 to 8.2

AN/UPM-6A,-6B**MODE SELECTOR POSITION**

1

2

3

SINGLE

DOUBLE

EMERG

**USEC
PULSE DURATION**

0.7 to 1.2

0.7 to 1.2

0.7 to 1.2

0.9 to 1.3

0.9 to 1.3

0.9 to 1.3

**USEC
PULSE SPACING**

2.5 to 3.5

4.5 to 5.5

7.5 to 8.5

12.5 to 19.5

12.5 to 19.5

MODULATION: Pulse.

ATTENUATOR RANGE (BELOW 1 V RMS)

AN/UPM-6: 15 to 115 db.

AN/UPM-6A,-6B: 20 to 120 db.

DEMODULATOR DATA**FREQUENCY RANGE**

AN/UPM-6: 950 to 1150 mc.

AN/UPM-6A,-6B: 960 to 1150 mc.

POWER INPUT RANGERF INPUT: 0.5 to 35 W pulse power,
0.25 W max average power.HIGH-POWER INPUT: 35 to 3500 W pulse
power, 5 W max average continuous
power, 10 W dissipation for 5 minutes
repeated not oftener than 15 minute
intervals.POWER MEASURING ACCURACY: ± 2 db over 0.5
to 3500 W pulse power range.**PEAK VOLTMETER DATA**RANGES: 0.5, 1, 2, 5, 10, 20, 50, 100,
200 v peak with meter scale graduations
of 0 to 5, 0 to 10, and 0 to 20.MEASURING CAPABILITIES: 0.1 to 200 v
positive polarity video pulses or pulse
trains having coder output pulse char-
acteristics and single pulses between
0.7 and 5.0 usec duration at 47 to 4100
pps.

RADAR TEST SET

AN/UPM-6,-6A,-6B

TRANSPONDER PROBE ANTENNA

ATTENUATION: 20 ±1.5 db.

POWER REQUIREMENTS

AN/UPM-6: 115 v ±15%, 47 to 2400 cps,
130 W at 60 cps or 20 to 30 v DC, 16
to 10 amps for Inverter PU-120/U.

AN/UPM-6A, -6B: 115 v ±10%, 50 to 1000 cps,
135 W at 60 cps.

AN/UPM-6

- (1) 5Y3WGTB
- (16) 5654/6AK5W
- (2) 5725/6AS6W
- (6) 5726/6AL5W
- (7) 6C4WA
- (1) 6L4
- (1) 6X5WGT
- (2) 2B22

AN/UPM-6A, -6B

- (1) 2C43
- (1) 5V4G
- (13) 5654/6AK5W
- (2) 5725/6AS6W
- (4) 5726/6AL5W
- (2) 6Y6G
- (1) 2B22

MANUFACTURER'S OR CONTRACTOR'S DATA

Hazeltine Electronics Corp, Little Neck,
N. Y.

Contract NXsr-79980 (AN/UPM-6).

Contract NObsr-52499, dated 8 June 1951
(AN/UPM-6A, -6B).

Contract NObsr-49255, dated 30 June
1950 (AN/UPM-6B).

Contract NObsr-52195, dated 29 December
1950 (AN/UPM-6A).

Contract NObsr-57584, dated 30 June
1952 (AN/UPM-6B).

Contract NObsr-63461, dated 29 May 1953
(FC-2 for AN/UPM-6B).

Approximate Cost: \$1950.00 with equip-
ment spares.

Total Tubes: (38)
(2) 1N25

Total Tubes: (34)
(1) 1N21B
(1) 1N25

Total Crystals: (2)

Total Crystals: (2)

REFERENCE DATA AND LITERATURE

NAVSHIPS 900951: Technical Manual for Radar
Test Set AN/UPM-6(XN-21).

NAVSHIPS 91467(A): Technical Manual for
Radar Test Set AN/UPM-6A and Radar Test
Set AN/UPM-6B.

TUBE AND/OR CRYSTAL COMPLEMENT

AN/UPM-6

- (1) OA2WA
- (1) OB2WA

AN/UPM-6A, -6B

- (1) OA2WA
- (9) 12AU7

TYPE CLASSIFICATION
DESIGN COGNIZANCE BUSHIPS
PROCUREMENT COGNIZANCE MIL-R-15532A(SHIPS)
STOCK NO.
R.D.B. IDENT. NO.

SHIPPING DATA

NUMBER OF BOXES	CONTENTS AND IDENTIFICATION	VOLUME (Cu.Ft.)	OVERALL DIMENSIONS (inches)	WEIGHT PACKED (lbs.)
	AN/UPM-6 SHIPPING DATA NOT AVAILABLE			
1	AN/UPM-6A Radar Test Set AN/UPM-6A	7.0	19-1/2 X 22 X 28	182
1	Set of Equipment Spares (BUSHIPS) or Set of Equipment Spares (USMC)	2.5 4.5	12 X 16 X 22-1/2 12 X 19 X 34	23 85
1	AN/UPM-6B Radar Test Set AN/UPM-6B	7.6	19-1/2 X 23-7/8 X 28	118
1	Set of Equipment Spares (BUSHIPS) or Set of Equipment Spares (USMC)	2.5 4.5	12 X 16 X 22-1/2 12 X 19 X 34	23 85

April 1958

Test Combination and Group

AN/UPM-6,-6A,-6B

RADAR TEST SET

EQUIPMENT SUPPLIED DATA

QUANTITY PER EQUIPT	NAME AND NOMENCLATURE			OVERALL DIMENSIONS (inches)	WEIGHT (lbs.)
	AN/UPM-				
	6	6A	6B		
1				13-1/4 X 13-3/4 X 17	62.4
1	1			TS-718/UPM-6A or	67.5
		1		TS-721/UPM-68	67.5
1				Video Probe MX-796/UP	0.8
1	1	1		RF Probe MX-796A/UPM-6	0.8
1				Inverter PU-120/U	10.1
1				Case CY-595/UPM-6 or	32.7
	1	1		CY-1049/UPM-6A	32.7
1				Transponder Probe Antenna AS-332/UP	4.8
1				Case CY-594/UPM-6	3.3
	1			Test Set Cover CW-264/UPM-6A or	6.4
		1		CW-265/UPM-68	8.4
1	1	1		Adapter UG-309/U	0.1
1	1	1		Adapter UG-273/U	0.1
1	1	1		Adapter UG-201/U	0.1
1				Cable RG-55/U	0.1
	1	1		Cable RG-55/U	0.1
1				Cable DCOP-2	0.8
1				Cable DCOP-2	2.8
	1	1		Cable DCOP-3	0.8
1	1	1		Cable RG-62/U	1.0
1	1	1		Cable RG-58/U	0.4
5	5	5		Wavemeter Calibration Chart	
2	2	2		Demodulator Power Calibration Chart	
1	1	1		RF Signal Generator Calibration and Demodulator Frequency Correction Chart	
1	1	1		DB to Watts Conversion chart	
13				RF Setting Card	
1	1	1		Alligator Clip	0.1
1	1	1		Content Index Chart	
	1	1		Carrying Strap	
1				Set of Equipment Spares	
	1	1		Set of Equipment Spares (BUSHIPS) or	13.0
				Set of Equipment Spares (USMC)	55.0

1 June 1962

Cog Service: USN FSN:

RADAR TEST SET AN/UPM-8

Functional Class: 10.1

USA

USN

USAF

TYPE CLASS:

Used by

Std

MANUFACTURER'S NAME/CODE NUMBER: Hazeltine Electronics Corp., (27876).

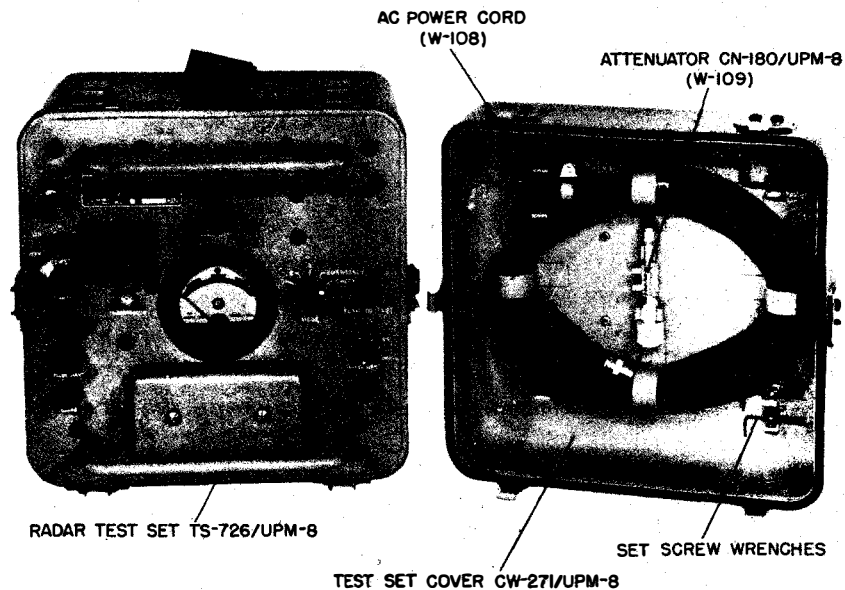

Radar Test Set AN/UPM-8

FUNCTIONAL DESCRIPTION:

Radar Test Set AN/UPM-8 is a portable, ac operated instrument, designed to perform rapid pre-flight checks of installed transponders or transponder sets. The following features of transponders are checked simultaneously: transmitter frequency, relative transmitter power output, decoding of mode 1, 2 or 3 interrogations, reply coding (number but not spacing of pulses), receiver frequency, relative receiver triggering level. The results of these checks are simultaneously resolved into a single REJECT or ACCEPT indication on an operating panel meter.

No field changes in effect at time of preparation (16 February 1962).

TECHNICAL CHARACTERISTICS:

SIGNAL GENERATOR

FREQUENCY CONTROL: Crystal.

AN/UPM-8 RADAR TEST SET

FREQUENCY RANGE: 1007.5 to 1032.5 mc.

ATTENUATOR: Continuously variable to provide an open-circuit output during pulse of between 48 and 100 db below 1 v measured at transponder end of ATTENUATOR CN-180/UPM-8.

MODULATION: 900 porm 25 pps of 0.8 to 1.1 usec duration.

PULSE SPACING

MODE 1: 3.0 porm 0.2 usec.

MODE 2: 5.0 porm 0.2 usec.

MODE 3: 8.0 porm 0.2 usec.

PULSED POWER SUPPLY: Supplies positive pulses of approx. 280 v amplitude and 40 usec duration.

RECEIVER

FREQUENCY CONTROL: Crystal.

FREQUENCY RANGE: 1087.5 to 1112.5 mc.

LOCAL OSCILLATOR STABILITY: Within porm 200 kc.

POWER REQUIREMENTS: 115 v porm 10%, 50 to 1000 cyc, approx. 125 W.

RELATION TO OTHER EQUIPMENT: None.

EQUIPMENT REQUIRED BUT NOT SUPPLIED:

(1) Transponder Probe Antenna AS-332/UP; (1) Technical Manual for Radar Test Set AN/UPM-4A(NAVSHIPS 91556(A)).

MAJOR COMPONENTS

QTY	ITEM	STOCK NUMBERS	DIMENSIONS (INCHES)	WEIGHT (LBS)
1	Radar Test Set AN/UPM-8 includes:			33.1
1	Radar Test Set TS-726/UPM-8		8-1/4 x 11-3/4 x 11-3/4	27
1	Carrying Case w/Cover, Test Set CW-271/UPM-8		12-1/4 x 12-3/8 x 12-3/8	4
1	Cable Ass'y, Power, Electrical		120 lg	0.8
1	Attenuator CN-180/UPM-8		120 lg	0.4
1	No. 4 Set Screw Wrench (Allen type)			0.1
1	No. 6 Set Screw Wrench (Allen type)			0.1
1	No. 8 Set Screw Wrench (Allen type)			0.1
1	Technical Manual		1/2 x 9 x 11-1/2	0.6

REFERENCE DATA AND LITERATURE:

AN16-30UPM8-3: Technical Manual for Radar Test Set AN/UPM-8.

NAVSHIPS 91537(A): Technical Manual for Radar Test Set AN/UPM-8.

TUBE, CRYSTAL AND/OR SEMI-CONDUCTOR DATA:

TUBES: (1) 0A2 (1) 0B2 (1) 2D21W (2) 6AH6 (2) 6AK5W (1) 6AL5W (6) 6AN5 (1) 6AU6
(3) 6D4 (2) 6F4 (2) 6X4 (2) 12AT7 (2) 12AU7 (1) 5675 (1) 5687 (1) 5876

CRYSTALS: (2) CR-23/U

SEMI-CONDUCTORS: (8) 1N70 (2) 1N72

4.10 AN/UPM-8: 2

SHIPPING DATA

PKGS	VOLUME (CU FT)	WEIGHT (LBS)
1	2.5	63

PROCUREMENT DATA

PROCURING SERVICE: USN
 SPEC &/OR DWG: MIL-R-15219A(SHIPS)

DESIGN COG: USN, BuShips

CONTRACTOR	LOCATION	CONTRACT OR ORDER NO.	APPROX. UNIT COST
Hazeltine Electronics Corp.	Little Neck, N. Y.	NObsr-49259,	\$650.24
		30 June 1950	
		NObsr-57585	\$778.36
		NObsr-59298,	\$971.49
		21 December 1950	

UNCLASSIFIED

April 1959

Test-Combination and Group

RADAR TEST SET

AN/UPM-8A

FUNCTIONAL DESCRIPTION

The AN/UPM-8A is a portable test set designed to perform rapid pre-flight checks of installed transponders or transponder sets. It will simultaneously test transmitter frequency, relative transmitter power output, decoding of mode 1, 2 or 3 interrogations, reply coding, receiver frequency, and relative receiver triggering level. The results of these checks are simultaneously resolved into a single "reject" or "accept" indication on an operating panel meter.

No field changes in effect at time of preparation (30 July 1958).

RELATION TO OTHER EQUIPMENT

The AN/UPM-8A is interchangeable with the AN/UPM-8, but the parts used in the production of the AN/UPM-8A are of Canadian manufacture.

ELECTRICAL AND MECHANICAL CHARACTERISTICS

SIGNAL GENERATOR DATA

FREQUENCY RANGE: 1007.5 to 1032.5 mc.

PULSE DATA

REPETITION RATE: 900 ±25 pps.

DURATION: 0.9 to 1.3 usec.

SPACING: 3.5 to 8.0 ±0.2 usec.

TYPE: Paired pulses.

RECEIVER FREQUENCY RANGE: 1087.5 to 1112.5 mc.

POWER REQUIREMENTS: 115 v ±10%, 50 to 1000 cps, single ph, 125 W.

MANUFACTURER'S OR CONTRACTOR'S DATA

Dominion Electrohome Industries Ltd, Kitchener, Ontario.

TUBE AND/OR CRYSTAL COMPLEMENT

No Electron Tube or Crystal data available.

REFERENCE DATA AND LITERATURE

Nomenclature Card for Radar Test Set AN/UPM-8A.

TYPE CLASSIFICATION
DESIGN COGNIZANCE BUSHIPS
PROCUREMENT COGNIZANCE
STOCK NO.
R.D.B. IDENT. NO.

EQUIPMENT SUPPLIED DATA

QUANTITY PER EQUIPT	NAME AND NOMENCLATURE	OVERALL DIMENSIONS (inches)	WEIGHT (lbs.)
1	Radar Test Set AN/UPM-8A consisting of: Radar Test Set TS-276A/UPM-8 Fixed Attenuator CN-180A/UPM-8 Test Set Cover CW-271A/UPM-8	11-1/2 x 11-1/2 x 12	

UNCLASSIFIED

4.10 AN/UPM-8A: 1

28 May 1962

Cog Service: USN

FSN:

RADAR TEST SET AN/UPM-8B

Functional Class: 10.1

USA

USN

USAF

TYPE CLASS:

Used By

MANUFACTURER'S NAME/CODE NUMBER: Brubaker Electronics Inc., (91000).

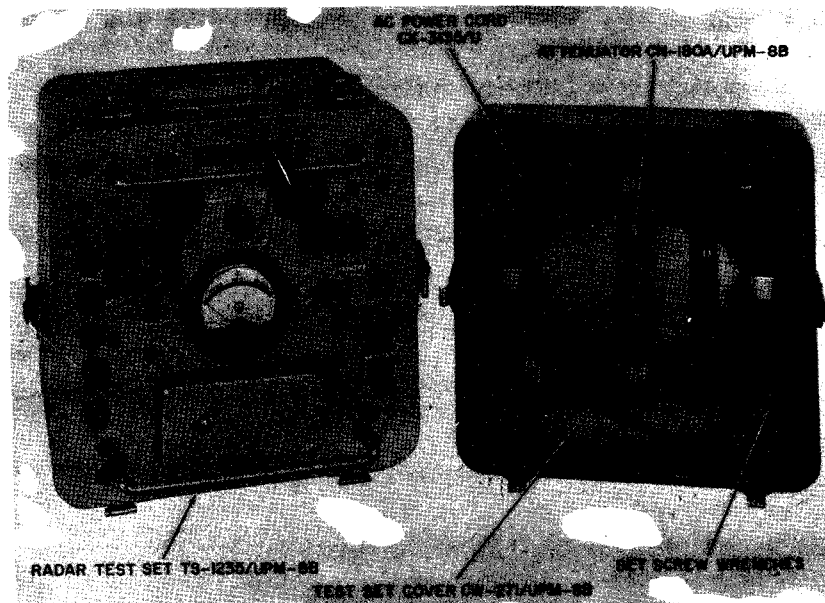

Radar Test Set AN/UPM-8B

FUNCTIONAL DESCRIPTION:

Radar Test Set AN/UPM-8B is a portable, ac operated instrument, designed to perform rapid pre-flight checks of installed transponders, such as those of the Mark X IFF system. The following features of transponders or associated Selective Identification Feature equipment can be checked simultaneously: transmitter frequency, relative transmitter power output, decoding of Mode 1, 2 or 3 interrogations, reply coding (number but not spacing of pulses for basic Mark X), relative receiver triggering level, proper code configurations (when SIF equipment is employed), pulse spacing. The results of these checks are simultaneously resolved into a single REJECT or ACCEPT indication of an operating panel meter.

No field changes in effect at time of preparation (16 February 1962).

TECHNICAL CHARACTERISTICS:

SIGNAL GENERATOR
FREQUENCY CONTROL: Crystal.

AN/UPM-8B RADAR TEST SET

FREQUENCY RANGE: 1007.5 to 1032.5 mc.

ATTENUATOR: Continuously variable to provide an open-circuit output during pulse of between 48 and 100 db below 1 v measured at transponder end of Attenuator CN-180/UPM-8.

MODULATION: 900 porm 25 pps of 0.8 to 1.1 usec duration.

PULSE SPACING

MODE 1: 3.0 porm 0.2 usec.

MODE 1 I/P: 3.0 porm 0.2 usec.

MODE 2: 5.0 porm 0.2 usec.

MODE 3: 8.0 porm 0.2 usec.

PULSED POWER SUPPLY: Supplies positive pulses of approx. 280 v amplitude and 40 usec duration.

RECEIVER

FREQUENCY CONTROL: Crystal.

FREQUENCY RANGE: 1087.5 to 1112.5 mc.

LOCAL OSCILLATOR STABILITY: Within porm 200 kc.

POWER REQUIREMENTS: 115 v porm 10%, 50 to 1000 cyc, approx. 125 W.

RELATION TO OTHER EQUIPMENT: None.

EQUIPMENT REQUIRED BUT NOT SUPPLIED:

- (1) Transponder Probe Antenna AS-332/UP;
- (1) Technical Manual for Coder Group AN/APA-89;
- (1) Technical Manual for Radar Test Set AN/UPM-4A (NAVSHIPS 91556(A)).

MAJOR COMPONENTS

QTY	ITEM	STOCK NUMBERS	DIMENSIONS (INCHES)	WEIGHT (LBS)
1	Radar Test Set AN/UPM-8B includes:			53.4
1	Radar Test Set TS-1235/UPM-88		8-1/2 x 13-1/4 x 13-1/4	41.0
1	Carrying Case w/Cover, Test Set CW-271/UPM-8		13-1/4 x 13-1/4 x 14-1/8	9.0
1	Cable Assy, Power, Electrical CX-3135/U		120 lg	0.8
1	Attenuator CN-180A/UPM-8		120 lg	0.4
1	No. 4 Set Screw Wrench (Allen type)			0.1
1	No. 6 Set Screw Wrench (Allen type)			0.1
1	No. 8 Set Screw Wrench (Allen type)			0.1
2	Handbook of Operating Instructions NAVWEPS 16-30UPM8-501		1/2 x 9 x 11-1/2	0.6
2	Handbook of Service Instructions NAVWEPS 16-30UPM8-502		1/2 x 9 x 11-1/2	0.8
2	Illustrated Parts Breakdown NAVWEPS 16-30UPM8-503		1/2 x 9 x 11-1/2	0.5

REFERENCE DATA AND LITERATURE:

NAVWEPS 16-30UPM8-501: Handbook of Operating Instructions for Radar Test Set TS-1235/UPM-8B.
 NAVWEPS 16-30UPM8-502: Handbook of Service Instructions for Radar Test Set AN/UPM-8B.
 NAVWEPS 16-30UPM8-503: Illustrated Parts Breakdown for Radar Test Set TS-1235/UPM-8B.

TUBE, CRYSTAL AND/OR SEMI-CONDUCTOR DATA:

TUBES: (1) 0A2WA (1) 0B2WA (1) 2D21W (2) 6AH6 (2) 6AK5W (1) 6AL5W (6) 6AN5
 (1) 6AU6WA (3) 6D4 (2) 6F4 (2) 6X4W (2) 12AT7WA (2) 5670 (1) 5675
 (1) 5687 (2) 5814A (1) 5876

CRYSTALS: (1) CR-14-1 (1) CR-14-2

SEMI-CONDUCTORS: (1) 2N274

SHIPPING DATA

PKGS	VOLUME (CU FT)	WEIGHT (LBS)
1	2.8	59.4

PROCUREMENT DATA

PROCURING SERVICE: USN DESIGN COG: USN, BuWeps
 SPEC &/OR DWG:

CONTRACTOR	LOCATION	CONTRACT OR ORDER NO.	APPROX. UNIT COST
Brubaker Electronics Inc.	Culver City, Calif.	N0as57-212f	

6 March 1963

Cog Service: USN

FSN: F6625-580-3771

RADAR TEST SET AN/UPM-98

Functional Class: 10.1

USA

USN

USAF

TYPE CLASS:

Std

MANUFACTURER'S NAME/CODE NUMBER: Admiral Corp., (70117).

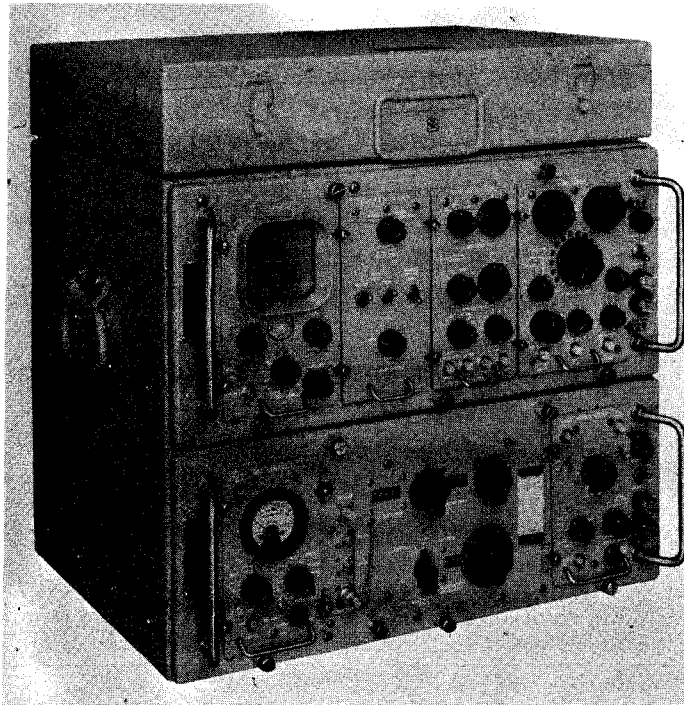

Radar Test Set AN/UPM-98

FUNCTIONAL DESCRIPTION:

Radar Test Set AN/UPM-98 is a transportable test equipment providing specialized facilities for performing maintenance test and calibration adjustments on various IFF type Mark X and SIF code identification equipments. It can also be used to perform some common tests required for maintenance of other radar equipments operating in the 925 to 1225 mc frequency range.

This equipment contains two major units, Radar Test Set TS-1253/UP and Coder Simulator SM-197/UPM-98, housed in Electrical Equipment Case CY-2726/UPM-98. Functionally, the Radar Test Set AN/UPM-98 consists of the following independent sections: Precision Oscilloscope, SIF Reply Code Simulator, Mark X Interrogation and Reply Simulator, Pulsed RF Signal Generator, Wavemeter, Demodulator, Pulse Counter, Calibrated Video Pulse Generator.

No field changes in effect at time of preparation (8 June 1962).

AN/UPM-98 RADAR TEST SET

TECHNICAL CHARACTERISTICS:**RADAR TEST SET AN/UPM-98**

POWER SOURCE REQUIRED: 115 v ac Porm 10%, single phase, 57 to 420 cps (depending on blower fan frequency requirement), 600 W, 5.5 amperes at a power factor of 95%.

RADAR TEST SET TS-1253/UP ELECTRICAL CHARACTERISTICS**TRIGGER PULSE**

POLARITY: Positive.

WIDTH: 0.3 to 3 microseconds.

AMPLITUDE: 50 to 100 v into 500 ohms load bypassed by 175 uuf capacitor; 20 volts into 75 ohms load bypassed by 1100 uuf capacitor.

PRF: 15 to 4100 cps.

DELAY: 0 to 750 microseconds.

SUPPRESSOR PULSE

POLARITY: Positive.

WIDTH: 2 to 220 microseconds.

AMPLITUDE: 20 volts into 500 ohm load bypassed by 175 uuf capacitor; 3 volts into 75 ohm load bypassed by 1100 uuf capacitor.

PRF: 15 to 4100 cps.

INTENSITY MARKERS

TYPE: Intensity modulation of oscilloscope display.

SPACING: 0.1, 0.1 and 1.0, 5.0, and 50.0 microseconds.

MARKER WIDTH: Less than 0.02 microseconds.

CRYSTAL MARKERS

TYPE: Positive and negative display on time sharing basis with video.

SPACING: 1.0 or 1.45 microseconds.

AMPLITUDE: Variable to one inch display, independent of vertical attenuation.

MARKER WIDTH: Less than 0.02 microseconds.

CONTROL CRYSTALS

GOVERNMENT DESIGNATION:

3Y1

3Y2

CR-18/U

CR-18/U Modified
by Admiral Drawing
593A25.

FREQUENCY RANGE OF CRYSTAL CIRCUIT:

999,500 to
1,000,500 cps

689,310 to
690,000 cps.

OSCILLATION FREQUENCY:

1 mc

689,655 kc.

EQUIPMENT OUTPUT FREQUENCY:

1 mc

689,655 kc.

FREQUENCY ACCURACY OVER OPERATING RANGE:

0.005%

0.005%.

OSCILLOSCOPE

VERTICAL SENSITIVITY: Calibrated settings at 0.05, 0.1, 0.2, 0.5, 1.0, 2.0, 5.0, 10.0, and 20.0 volts per inch.

VERTICAL RISE TIME: Less than 0.05 usec.

HORIZONTAL SWEEP SPEED: Variable from 1 to 20,000 usec per sweep.

HORIZONTAL SWEEP DELAY: 0 to 750 microseconds.

FREQUENCY RESPONSE: Essentially flat from 50 cps to 6 mc.

SIF REPLY CODES (UP TO 12 INFORMATION PULSES, PLUS TWO FRAMING PULSES, "X" PULSE, AND "ID" PULSE)

POLARITY: Positive.

AMPLITUDE: (a) High - approx 7 v at VARI OUTPUT connector; 45 v at MOD DRIVE connector;
 (b) Low - approx 5 v at VARI OUTPUT connector; 25 v at MOD DRIVE connector.
 PULSE WIDTH: 0.3 to 1.0 microsecond (nominal 0.45 usec).
 PULSE SPACING: 1.45 microseconds.
 RESIDUAL DELAY: 4 microseconds or less from application of input trigger.

SUBSTITUTE PULSE

POLARITY: Positive.
 AMPLITUDE: (a) High - approx 7 v at VARI OUTPUT connector; 45 v at MOD DRIVE connector;
 (b) Low - approx 5 v at VARI OUTPUT connector; 25 v at MOD DRIVE connector.
 WIDTH: 0.3 to 1.0 microsecond (nominal 0.45 usec).
 RESIDUAL DELAY: 4 microseconds or less from application of input trigger.
 POSITION: Any selected pulse in the reply train except the first framing pulse and ID pulse. The substitute pulse is variable to form 1.6 microseconds of the position of deleted pulse.

PULSE MODULATED RF SIGNAL

FREQUENCY RANGE: 925 to 1225 mc, continuously tunable.
 POWER: M21 to M121 db below one volt, continuously variable.
 STANDING WAVE RATIO: Less than 2 db into a 53.5 ohm line.
 RESIDUAL DELAY: Not more than 0.3 microseconds.

WAVEMETER

FREQUENCY RANGE: 925 to 1225 mc.
 ACCURACY: Form 0.7 mc.

PULSE COUNTER

RANGES: (a) 0 to 500 pulses/sec; (b) 0 to 5000 pulses/sec.
 ACCURACY: Form 5% at full scale, form 10% at one-tenth of scale.

CALIBRATION PULSES

DURATION: 2.5 form 0.5 microseconds.
 AMPLITUDE: 0.1, 0.5, 1, 2, 5, 10, and 50 volts.
 PRF: 47 to 4100 pps.

IFF INTERROGATION PULSE PAIRS

POLARITY: Positive or Negative.
 AMPLITUDE: 35 volts min into 75 ohms resistive load.
 PULSE SPACING: Mode 1 - 3 usec; Mode 2 - 5 usec; Mode 3 - 8 usec.
 PULSE WIDTH: 0.5 to 1.3 usec.
 PULSE RISE TIME: 0.1 usec max.
 PULSE DECAY TIME: 0.2 usec max.

MARK X REPLIES

TYPES: SGL - Single Pulse; DBL - Two pulses spaced 16 usec apart; EMER - Four pulses spaced 16 usec apart.
 POLARITY: Positive or Negative.
 AMPLITUDE: 35 volts min into 75 ohms resistive load.
 PULSE WIDTH: 0.5 to 1.3 usec.
 RISE TIME: 0.1 usec max.
 DECAY TIME: 0.2 usec max.

TYPE OF INSTALLATION: Portable or permanent.

MOUNTING DIMENSIONS

RADAR TEST SET AN/UPM-98: 23-3/4 x 19-3/4 x 19-5/8 in.
 ACCESSORIES CASE CY-2725/UPM-98: 22-1/8 x 16-7/8 x 4-5/8 in.

NUMBER OF OPERATORS REQUIRED: One.

AN/UPM-98 RADAR TEST SET

RELATION TO OTHER EQUIPMENT:

Radar Test Set AN/UPM-98 is functionally similar to and is produced as a replacement for Radar Test Set AN/UPM-99, which is a field changed Radar Test Set AN/UPM-4A.

Radar Test Set TS-1253/UP, which contains the oscilloscope and SIF Coder sections of the Radar Test Set AN/UPM-98, is also supplied separately in its own electrical equipment case including applicable accessories as Radar Test Set AN/UPM-111 and AN/GPM-44.

EQUIPMENT REQUIRED BUT NOT SUPPLIED: None.

MAJOR COMPONENTS

QTY	ITEM	STOCK NUMBERS	DIMENSIONS (INCHES)	WEIGHT (LBS)
1	Radar Test Set AN/UPM-98 includes:		19-5/8 x 19-3/4 x 23-3/4	153
1	Radar Test Set TS-1253/UP			
1	Coder Simulator SM-197/UPM-98			
1	Electrical Equipment Case CY-2726/UPM-98			
1	Accessories Case CY-2725/UPM-98 containing:		4-3/4 x 16-1/2 x 22-5/8	19
1	Test Lead MX-2681/UP			
1	Cathode Ray Tube Visor MX-2953/UPM			
1	Cable Assy, Special Purpose, Electrical CX-4963/UPM		36 1g	
1	Cable Assy, Special Purpose, Electrical CX-4964/UPM		30 1g	
1	Cable Assy, Special Purpose, Electrical CX-6092/U		36 1g	
1	Cable Assy, Radio Frequency CG-409E/U		62-1/8 1g	
1	Cable Assy, Radio Frequency CG-409E/U		122-1/8 1g	
1	Cable Assy, Radio Frequency CG-1848/U		6-1/8 1g	
4	Cable Assy, Radio Frequency CG-530B/U		62 1g	
3	Cable Assy, Radio Frequency CG-530B/U		10 1g	
2	Adapter, Connector UG-201/U			
3	Adapter, Connector UG-273/U			
2	Adapter, Connector UG-274/U			
2	Adapter, Connector UG-309/U			
4	Adapter, Connector UG-636/U			
2	Dummy Load, Electrical DA-232/U			

4.10 AN/UPM-98: 4

REFERENCE DATA AND LITERATURE:

NAVSHIPS 93576: Technical Manual for Radar Test Set AN/UPM-98.
 NAVSHIPS 93576.21: Operating Instructions for Radar Test Set AN/UPM-98.
 NAVSHIPS 93576.32: Performance Standards Sheet.
 NAVSHIPS 93576.42: Maintenance Standards Book.

TUBE, CRYSTAL AND/OR SEMI-CONDUCTOR DATA:

TUBES: (2) 1V2 (2) 2822 (1) 2C36 (1) 4MP1 (2) 6AH6WA (3) 6AU6WA (2) 6BQ5
 (1) 6D4 (6) 6U8A (9) 12AT7WA (2) 12BY7 (1) NE82 (1) OB2WA (2) 5651WA
 (3) 5670 (9) 5687WA (2) 5726/6AL5W (18) 5814A (3) 6080WA (1) 6101/6J6W
 (3) 6216

CRYSTALS: (1) CR-18/U (1) CR-18/U modified

SEMI-CONDUCTORS: (50) 1N126A (7) 1N277 (22) 1N281 (2) 1N459 (3) 1N643 (11) 1N645
 (1) AZ-13

SHIPPING DATA

PKGS	VOLUME (CU FT)	WEIGHT (LBS)
1	11	248

PROCUREMENT DATA

PROCURING SERVICE: USN DESIGN COG: USN, BuShips
 SPEC &/OR DWG: SHIPS-T-3268

CONTRACTOR	LOCATION	CONTRACT OR ORDER NO.	APPROX. UNIT COST
Admiral Corp. Pt/Dwg no. 597E120	Chicago, Illinois	NObsr-75944, 26 June 1959	\$4,658.00
		NObsr-81595, 30 June 1960	\$4,997.00

11 July 1962
Cog Service:

6625-752-7660
6625-752-7680
FSN: (less MX-1324/UPM-4A)

RADAR TEST SET AN/UPM-99
Functional Class:

USA

USN

USAF

TYPE CLASS:

MANUFACTURER'S NAME/CODE NUMBER: Admiral Corporation.

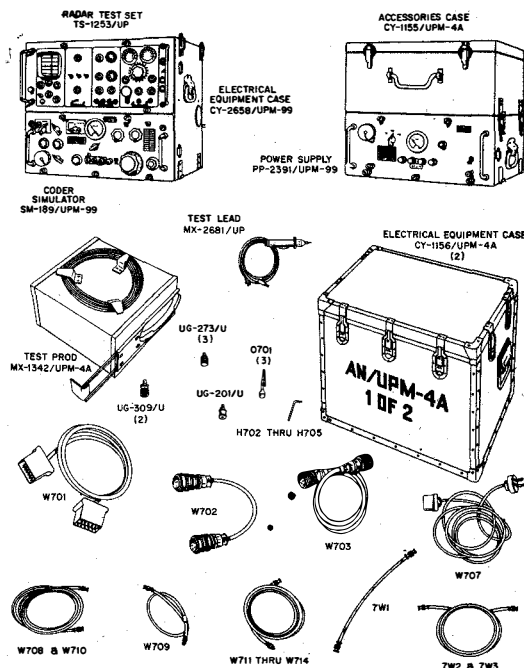

Radar Test Set AN/UPM-99

FUNCTIONAL DESCRIPTION:

Radar Test Set AN/UPM-99 has been specifically designed for testing IFF equipment of both the Mark 10 and SIF (Selective Identification Feature) type. It will also perform some of the more common tests required for maintenance of radar equipments operating in the 925 mc to 1225 mc frequency range.

No field changes in effect at time of preparation (17 December 1959).

TECHNICAL CHARACTERISTICS:

RADAR TEST SET TS-1253/UP

PRESENTATION: 4-1/4 in. rectangular CR tube.

VERTICAL AMPLIFIER

POLARITY: Pos (video), neg (deflection).

AN/UPM-99 RADAR TEST SET

SENSITIVITY: 0.05, 0.1, 0.2, 0.5, 1.0, 2.0, 5.0, 10.0, 20.0 v/in.

SWEEP DURATION: 1 to 20,000 usec.

SWEEP REPETITION: 15 to 4,100 sweep-per sec.

SWEEP LINEARITY: 5% from start to finish.

TRIGGER PULSE WIDTH: 0.5 to 3.0 usec.

CODER SIMULATOR SM-189/UPM-99

FREQUENCY RANGE: 925 to 1,225 mc, continuous.

TYPE OF FREQUENCY CONTROL: Tuned plate, tuned grid.

TYPE OF MODULATION: Pulse.

OUTPUT IMPEDANCE: 53.5 ohms.

POWER SUPPLY PP-2391/UPM-99

INPUT: 115 v porm 15%, 60 cyc.

OUTPUT: P300 v dc, M27 v dc unregulated.

RELATION TO OTHER EQUIPMENT: None.

EQUIPMENT REQUIRED BUT NOT SUPPLIED: None.

MAJOR COMPONENTS

QTY	ITEM	STOCK NUMBERS	DIMENSIONS (INCHES)	WEIGHT (LBS)
1	Radar Test Set AN/UPM-99 includes:			
1	Radar Test Set TS-1253/UP		9.75 x 16 x 22.3	
1	Coder Simulator SM-189/UPM-99		8.8 x 15 x 22.3	40
1	Power Supply PP-2391/UPM-99		10 x 19.5 x 23.8	70
1	Electrical Equipment Case CY-2658/UPM-99		19.5 x 24	40
1	Accessories Case CY-1155/UPM-4A		10 x 17.3 x 23.3	37
2*	Electrical Equipment Case CY-1156/UPM-4A		22 x 22.5 x 26	45
1	Test Prod MX-1342/UPM-4A		9 x 9 x 11.8	2.5
1	Test Lead MX-2681/UP		60 lg	
1	Maintenance Standard Book			
1	Operator's Instruction Chart			
2	Technical Manual		1.5 x 9.3 x 11.5	
1	Visor (7MP1)			
1	Service Cable (7W1)			
1	Service Cable (W701)		60 lg	
1	Power Cable (W702)		16.8 lg	
1	Power Cable (W703)		61.92 lg	
1	Power Cable (W707)		120 lg	
1	RF Cable (W708)		9.964 lg	
1	RF Cable (W710)		60 lg	
1	Video Cable (7W2)		24 lg	
1	Video Cable (7W3)		24 lg	
1	Video Cable (W709)		15 lg	
1	Video Cable (W711)		60 lg	
1	Video Cable (W712)		60 lg	
1	Video Cable (W713)		60 lg	
1	Video Cable (W714)		60 lg	

RADAR TEST SET AN/UPM-99

QTY	ITEM	STOCK NUMBERS	DIMENSIONS (INCHES)	WEIGHT (LBS)
1	Adapter BNC-HN UG-309/U (E701)			
1	Adapter BNC-HN UG-309/U (E702)			
1	Adapter BNC-UHF UG-273/U (E703)			
1	Adapter BNC-UHF UG-273/U (E704)			
1	Adapter BNC-UHF UG-273/U (E705)			
1	Adapter BNC-N UG-201/U (E706)			
3	Clip, Alligator (0701)			
1	Allen Wrench #4 (H702)			
1	Allen Wrench #6 (H703)			
1	Allen Wrench #8 (H704)			
1	Allen Wrench #10 (H705)			
12	Blank Calibration Cords (N702)			
1	Book of Calibration Charts (N701)			

*Not supplied for ship board
installation.

REFERENCE DATA AND LITERATURE:

NAVSHIPS 00000: Technical Manual for Radar Test Set AN/UPM-99.

TUBE, CRYSTAL AND/OR SEMI-CONDUCTOR DATA:

TUBES: (1) 0A3 (1) 0B2WA (2) 1V2 (2) 2B22 (1) 2C36 (1) 5R4WGB (3) 6AG5
(2) 6AH6 (2) 6AU6WA (18) 6C4W (2) 6BQ5 (1) 6D4 (1) 6J6 (2) 6U8A
(6) 12AT7WA (1) 12BY7A (1) 5651WA (2) 5654WA (4) 5670 (8) 5687 (1) 5726
(15) 5814A (2) 6005 (3) 6080WA (1) 6216 (1) 41ACP1

CRYSTALS: (1) CR-18/U (1) CR-48/U

SEMI-CONDUCTORS: None used.

SHIPPING DATA

PKGS	VOLUME (CU FT)	WEIGHT (LBS)
1		
1		

PROCUREMENT DATA

PROCURING SERVICE:
SPEC &/OR DWG: SHIPS-S-3119

DESIGN COG: USN, BuShips

AN/UPM-99 RADAR TEST SET

CONTRACTOR	LOCATION	CONTRACT OR ORDER NO.	APPROX. UNIT COST
Admiral Corporation	Chicago 47, Illinois	N0bsr-71516, 14 August 1956	

September 1956

RADIO TEST SET**AN/URM-1***Radio Test Set AN/URM-1***FUNCTIONAL DESCRIPTION**

The AN/URM-1 is composed of several test units, each performing a different function. Sound Test Box TS-319/URM-1 is designed to function as an AF signal source for testing the hydrophone of the Radio Set AN/CRT-4. Hydrophone Magnetizer TS-320/URM-1 accomplishes the remagnetization of the hydrophones. Voltage Injector TS-322/URM-1 is designed for testing and adjusting the vacuum tube voltmeter circuit of the AN/ARR-16 Series Receivers. The CU-102/U Matching Network is used to couple the AF Signal Generator to the AN/CRT-4 transmitter when a known value of AF signal is necessary.

No field changes in effect at time of preparation (6 June 1956).

ELECTRICAL AND MECHANICAL CHARACTERISTICS

FREQUENCY: 200 to 1000 cps.
POWER SUPPLY REQUIRED: 202.5 v and 1.5 v battery.

MANUFACTURER'S OR CONTRACTOR'S DATA

Geophysical Service Incorporated, Dallas, Texas.
Contract NOa(s) 5425, dated 5 February 1945.
Approximate Cost: \$45703.00.

TUBE AND/OR CRYSTAL COMPLEMENT

No Electron Tubes.

UNCLASSIFIED

4.10 AN/URM-1: 1

AN/URM-1

RADIO TEST SET

September 1956

REFERENCE DATA AND LITERATURE

CO-AN16-30URM-1-2-M: Technical Manual for
Test Equipment AN/URM-1.

TYPE CLASSIFICATION DESIGN COGNIZANCE BUAER PROCUREMENT COGNIZANCE STOCK NO. R.D.B. IDENT. NO.

EQUIPMENT SUPPLIED DATA

QUANTITY PER EQUIPT	NAME AND NOMENCLATURE	OVERALL DIMENSIONS (inches)	WEIGHT (lbs.)
1	Hydrophone Magnetizer without batteries TS-320/URM-1	8 x 8 x 8	8.4
1	Voltage Injector without battery TS-322/URM-1	3 x 5 x 6-1/2	1.9
1	Impedance Matching Network CU-102/U	3 x 5 x 6	1.5
1	Transmitter Cable	72	0.25
1	Hydrophone Cable	72	0.25
1	Sound Test Box TS-319/URM-1	7-1/2 x 7-1/2 x 9-1/2	7.1
1	Tuning Tool TL-315/U	3/8 x 6-1/2	0.5
1	Tuning Test Case TS-321/URM-1	6-1/4 x 25-1/2	4.25
1	Spintite Wrench, 3/8 in.	1-1/4 x 6-3/4	0.2

February 1960

Test-Combination and Group

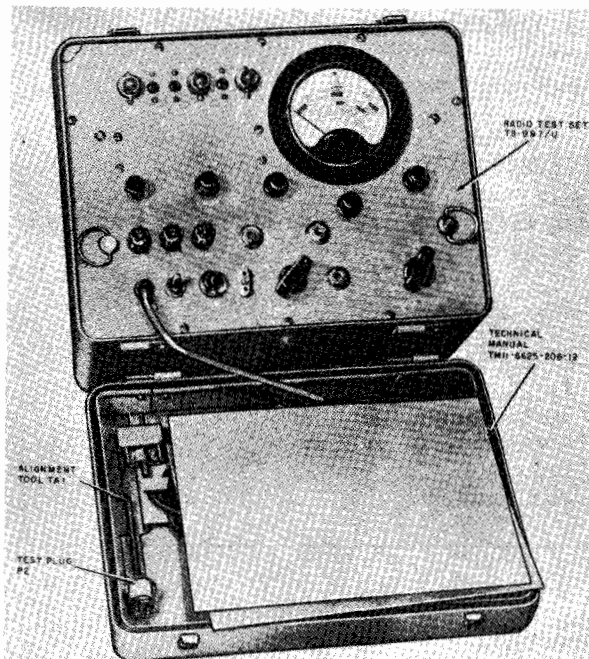
RADIO TEST SET**AN/URM-113**

Radio Test Set AN/URM-113

ELECTRICAL AND MECHANICAL CHARACTERISTICS**POWER SUPPLY**

VOLTAGE: 105 to 125 v AC.

FREQUENCY: 50 to 400 cy, single ph.

POWER: 35 W.

METER SENSITIVITY: 300 ua \pm 2%.CRYSTAL FREQUENCIES TESTED: 4.26 mc \pm 0.005%,
4.3 mc \pm 0.005%, 4.34 mc \pm 0.005%.**MANUFACTURER'S OR CONTRACTOR'S DATA**

Hickok Electrical Instrument Co, Cleveland, Ohio.

TUBE AND/OR CRYSTAL COMPLEMENT

(1) 0A2WA (3) 6AU6WA (1) 6X4WA

(1) 12AV7 (1) 5814A

Total Tubes: (7)

No Crystals used.

REFERENCE DATA AND LITERATURE

TM11-6625-206-12: Technical Manual for RADIO TEST SET AN/URM-113.

FUNCTIONAL DESCRIPTION

Radio Test Set AN/URM-113 is a portable equipment which provides the necessary signals, voltages, and metering circuits for the testing of plug-in units contained in Radio Sets AN/PRC-8, 8A, 9, 9A, 10, and 10A.

No field changes in effect at time of preparation (6 July 1959).

TYPE CLASSIFICATION
DESIGN COGNIZANCE TASSA
PROCUREMENT COGNIZANCE
STOCK NO.
R.D.B. IDENT. NO.

SHIPPING DATA

NUMBER OF BOXES	CONTENTS AND IDENTIFICATION	VOLUME (Cu.Ft.)	OVERALL DIMENSIONS (inches)	WEIGHT PACKED (lbs.)
1	Radio Test Set AN/URM-113	2.28	14 X 15 X 18-3/4	38

EQUIPMENT SUPPLIED DATA

QUANTITY PER EQUIPT	NAME AND NOMENCLATURE	OVERALL DIMENSIONS (inches)	WEIGHT (lbs.)
1	Radio Test Set AN/URM-113 Including:		19
1	Radio Test Set TS-997/U		
1	Test Plug		
1	Alignment Tool		
1	Technical Manual TM11-6625-206-12		
1 set	Running Spares		

UNCLASSIFIED

August 1957

Test-Combination and Group

RADIO TEST SET

AN/URM-4A

FUNCTIONAL DESCRIPTION

The AN/URM-4A consists of an audio oscillator, oscilloscope, multimeter, vacuum tube volt-ohm-milliammeter and a signal generator. It is designed for maintenance of Radio Set SCR-573-() and SCR-574-().

No field changes in effect at time of preparation (6 March 1957).

TUBE AND/OR CRYSTAL COMPLEMENT

No Electron Tubes.

REFERENCE DATA AND LITERATURE

Nomenclature Card for Radio Test Set AN/URM-4A dated 1 May 1947.

RELATION TO OTHER EQUIPMENT

Similar to and interchangeable with Radio Test Set AN/URM-4 but substitutes Navy Model OBQ for voltmeter RCA-165 and Navy Model LAJ for Signal Generator Hewlett-Packard 205-A.

TYPE CLASSIFICATION
DESIGN COGNIZANCE BUSHIPS
PROCUREMENT COGNIZANCE
STOCK NO.
R.D.B. IDENT. NO.

EQUIPMENT SUPPLIED DATA

QUANTITY PER EQUIPT	NAME AND NOMENCLATURE	OVERALL DIMENSIONS (inches)	WEIGHT (lbs.)
1	Audio Oscillator Equipment Model LAJ		
1	Oscilloscope Model OBL		
1	Test Set Model OZ		
1	Electronic Multimeter ME-6()/4		
1	Vacuum Tube Volt-Ohm-Milliammeter Model OBQ		
1	Signal Generator Model LX-1		

UNCLASSIFIED

September 1956

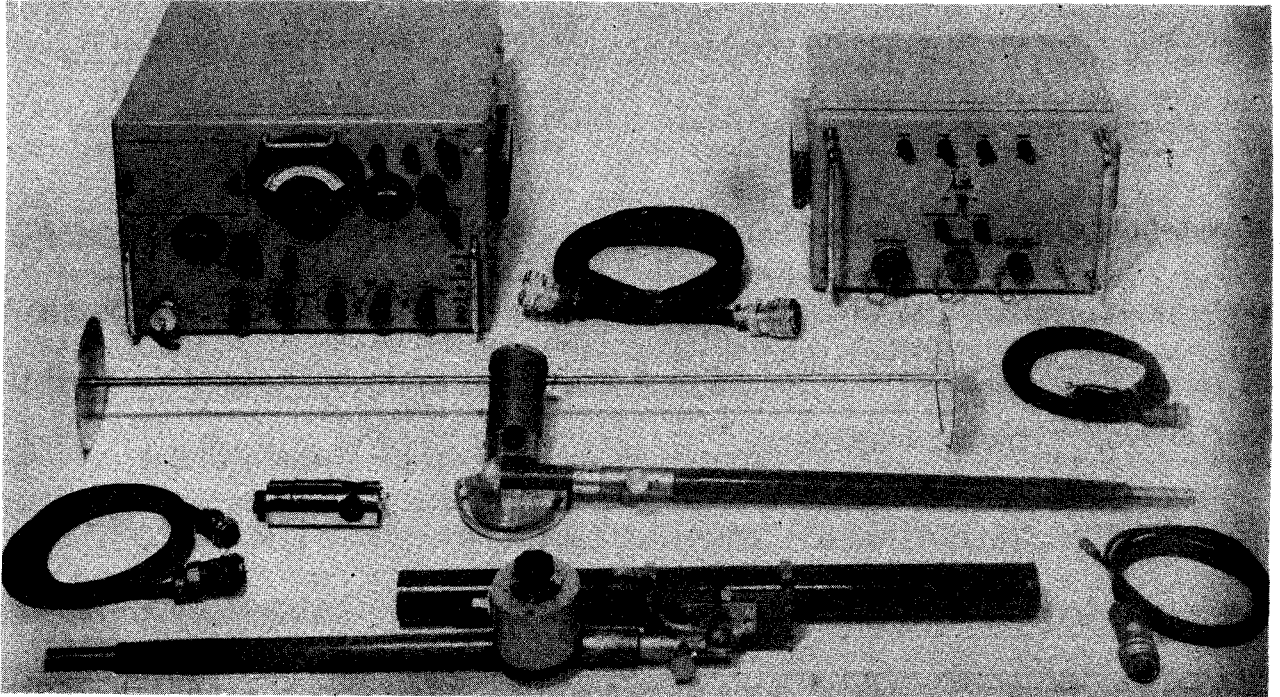
RADIO TEST SET**AN/URM-41***Radio Test Set AN/URM-41***FUNCTIONAL DESCRIPTION**

The AN/URM-41 is used to measure very low frequency radio interference and field intensities within the frequency range of 30 to 15000 cycles per second. It provides means for harmonic analysis of periodic and random disturbances in conjunction with direct coupling, electric or magnetic pickup. It may be used as a selective two terminal voltmeter with a choice of degree of selectivity or as a broadband voltmeter. It provides for rejection of a narrow band of frequencies anywhere in the frequency range of the equipment.

No field changes in effect at time of preparation (29 May 1956).

RELATION TO OTHER EQUIPMENT

Equipment Required but not Supplied: (1) Headphones, (1) Oscilloscope, (1) Audio Signal Generator with Metered Output, (1) Frequency Meter or Electronic Counter, (1) Vacuum Tube Voltmeter.

ELECTRICAL AND MECHANICAL CHARACTERISTICS

FREQUENCY RANGE: 30 to 15000 cps.

PRESENTATION

BROAD BAND: Response is flat from 30 to

15000 cps within 1 db, and voltages are read on linear scale of meter. sensitivity range is 100 uv to 1 v full scale reading as determined by attenuator setting. Meter reads average value, quasipeak value or peak value.

INTERMEDIATE SELECTIVITY: 3 db bandwidth is 10% of tuned frequency as indicated by tuning range switch and main tuning dial. Linear scale of meter is used, with sensitivity range of 100 uv to 1 v full scale reading as determined by attenuator setting. Meter reads average, quasipeak or peak values.

MAXIMUM SELECTIVITY: Two decade logarithmic meter scale is used. Full scale reading as determined by attenuator setting is 100 uv to 1 v. 1 uv min signals in amplitude may be measured. If selectivity switch conditions are available at 10 cps at 3 db and 200 cps at 3 db. Average, quasipeak and peak functions are available.

POWER REQUIREMENTS

POWER SUPPLY: 115 v AC, 60 cps.

ANTENNA DATA

MAGNETIC FIELD ANTENNA: Electrostatically shielded loop wound on magnetically permeable rod. Provisions made for adjusting to any desired orientation in vertical and horizontal planes. Calibrated Tuning Box is part of antenna. Arranged for use with tripod.

UNCLASSIFIED

4.10 AN/URM-41: 1

AN/URM-41

RADIO TEST SET

September 1956

ELECTRIC FIELD ANTENNA: Dipole type used in conjunction with a coupling unit and has provisions for adjustment to any orientation in vertical and horizontal planes. Arranged for use with tripod.

- (3) 5749 (5) 5751 (1) 5932
- (1) OB2 (1) 6AS7 (2) 12AT7
- (4) 6072 (1) 5U4 (1) 6AU6
- (1) 5651 (4) 5814-A (1) 5Y3GT
- (3) 6C4 (3) 5726 (4) 5879

Total Tubes: (39)

MANUFACTURER'S OR CONTRACTOR'S DATA

Televiso Corp., Des Plaines, Ill.
 Contract NObsr 52455, dated 15 June 1951.
 Approximate Cost: \$3420.00.

REFERENCE DATA AND LITERATURE

NAVSHIPS 92728: Technical Manual for Radio Test Set AN/URM-41.

TUBE AND/OR CRYSTAL COMPLEMENT

- (1) OA2 (2) 6AB4 (1) 6J6

TYPE CLASSIFICATION
DESIGN COGNIZANCE BUSHIPS
PROCUREMENT COGNIZANCE MIL-4-16120(SHIPS)
STOCK NO.
R.D.B. IDENT. NO.

EQUIPMENT SUPPLIED DATA

QUANTITY PER EQUIPT	NAME AND NOMENCLATURE	OVERALL DIMENSIONS (inches)	WEIGHT (lbs.)
1	Radio Interference-Field Intensity Meter ()/URM-41	12 X 17-1/4 X 20	78
1	Power Supply ()/URM-41	10-1/2 X 13-1/4 X 17	69
1	Set Accessories consisting of:		17
1	Magnetic Field Antenna		
1	Electric Field Antenna		
1	Two Terminal Voltmeter Probe		
4	Cables		

CAPACITANCE-INDUCTANCE-RESISTANCE TEST SET

AN/URM-90

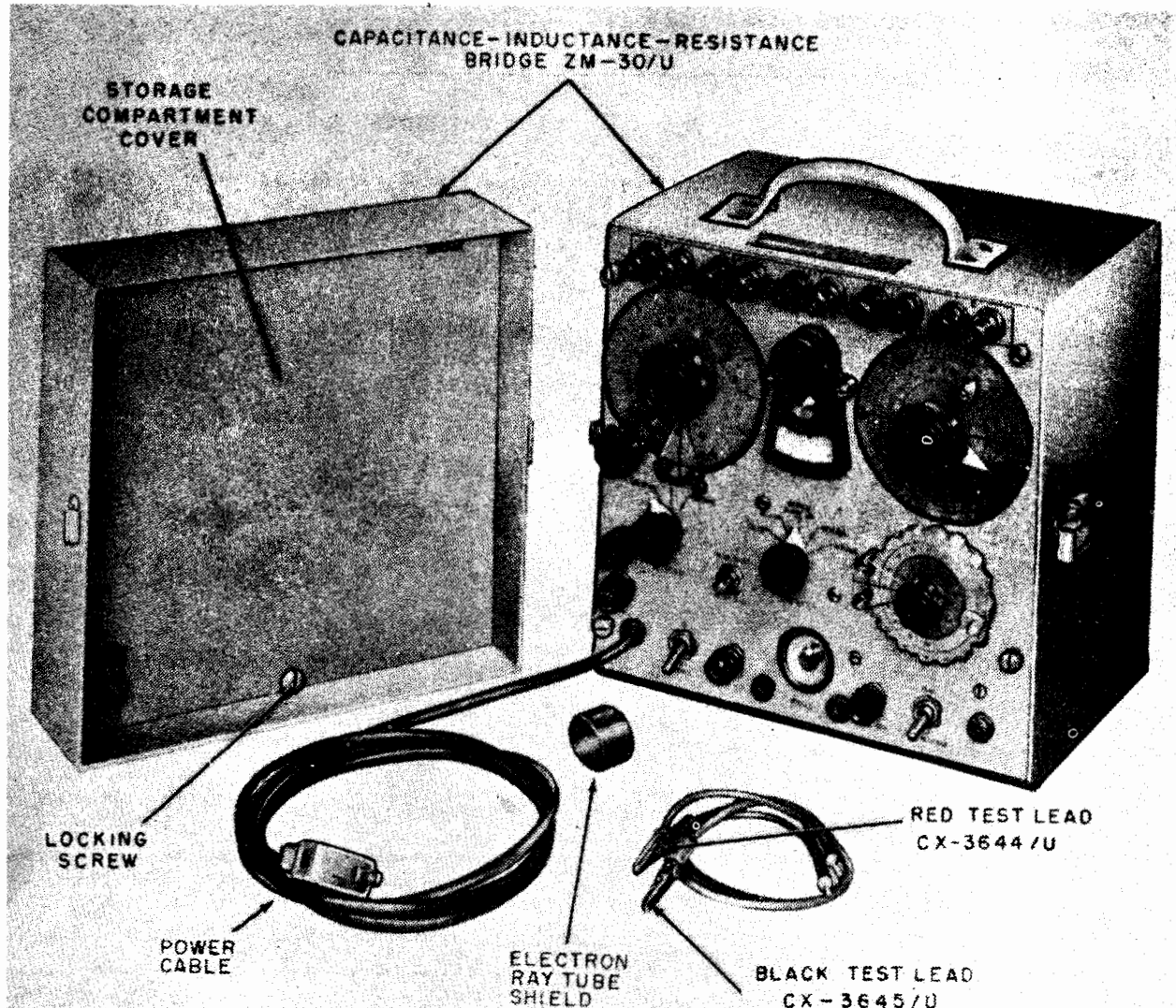

Capacitance-Inductance-Resistance AN/URM-90

FUNCTIONAL DESCRIPTION

The AN/URM-90 is a self-contained instrument used in electrical and electronic work where the values and characteristics of resistors, capacitors, and inductors must be accurately measured. The test set is used to make direct measurements of resistance capacitance, inductance, dissipation factors of capacitors, and the storage factors of inductors.

No field changes in effect at time of preparation (25 April 1957).

RELATION TO OTHER EQUIPMENT

Equipment Required but not Supplied: (1) Audio Oscillator TS-382/U, (1) Headset, (1) Voltmeter, (1) Multimeter, (1) Laboratory Standard AN/URM-2, (1) Decade Resistor TS-679A/U.

October 1957

Test-Combination and Group

AN/URM-90 CAPACITANCE-INDUCTANCE-RESISTANCE TEST SET

ELECTRICAL AND MECHANICAL CHARACTERISTICS

INTERNAL OSCILLATOR FREQUENCY: 1000 cps ± 10 cps.
 OPERATING FREQUENCY RANGE: 100 to 10,000 cps.
 INTERNAL DETECTORS
 AC MEASUREMENTS: Type 6U5 electron ray tube.
 DC MEASUREMENTS: Galvanometer.
 GALVANOMETER DATA
 RANGE: 7.5 to 0 to 7.5 ua.
 ACCURACY: 20%.

INTERNAL RESISTANCE: 1000 ohms.
 RANGES
 RESISTANCE: 0.1 milliohm to 11 meg.
 CAPACITANCE: 0.1 uuf to 1100 uf.
 INDUCTANCE: 0.1 uh to 1100 h.
 DISSIPATION FACTOR (R/X or D): 0.001 to 1.05.

STORAGE FACTOR (X/R or Q): 0.02 to 1000.
 ACCURACY

RESISTANCE: $\pm(0.15\% + 1$ division on the LRC inner dial).

CAPACITANCE: $\pm(0.5\% + 1$ division on the LRC inner dial).

INDUCTANCE: $\pm(1\% + 1$ division on the LRC inner dial).

DISSIPATION FACTOR (D): Expressed in terms of its reciprocal Q, $\pm(5\% + 0.0025)$ for capacitance values greater than .01 uf.

STORAGE FACTOR: Expressed in terms of its reciprocal D, $\pm(5\% + 0.0025)$.

POWER SOURCE REQUIRED: 115 v, 50 to 1000 cps, single ph, 18 W.

MANUFACTURER'S OR CONTRACTOR'S DATA

Model Engineering and Manufacturing Inc.,
 Huntington, Ind.
 Contract 37227-Phila-53, 25659-Phila-54.

TUBE AND/OR CRYSTAL COMPLEMENT

(1) 12AX7 (1) 12AT7 (1) 6U5

Total Tubes: (3)

REFERENCE DATA AND LITERATURE

TM11-2646AC1, Technical Manual for Capacitance-Inductance-Resistance Test Set AN/URM-90.

TYPE CLASSIFICATION	
DESIGN COGNIZANCE	TASSA
PROCUREMENT COGNIZANCE	
STOCK NO.	
R.D.B. IDENT. NO.	

SHIPPING DATA

NUMBER OF BOXES	CONTENTS AND IDENTIFICATION	VOLUME (Cu.Ft.)	OVERALL DIMENSIONS (inches)	WEIGHT PACKED (lbs.)
1	Capacitance - Inductance - Resistance Test Set AN/URM-90	1.8	10 X 14 X 22	57

EQUIPMENT SUPPLIED DATA

QUANTITY PER EQUIPT	NAME AND NOMENCLATURE	OVERALL DIMENSIONS (inches)	WEIGHT (lbs.)
1	Capacitance-Inductance-Resistance Bridge ZM-30/U	10-1/2 X 11 X 11-1/2	20-3/4
1	Red Test lead CX-3644/U	19 lg	
1	Black Test Lead CX-3645/U	19 lg	
1	Electron Ray Tube Shield		
2	Allen Set Screw Wrenches No. 8		
2	Allen Set Screw Wrenches No. 10		
1	Set of Spare Parts		

18 February 1963

Cog Service: USN

FSN:

MEASURING SET, WATER CURRENT AN/USQ-15()

Functional Class: 10

USA

USN

USAF

TYPE CLASS:

Used by

MANUFACTURER'S NAME/CODE NUMBER:

(No Illustration Available)

FUNCTIONAL DESCRIPTION:

The AN/USQ-15() is designed to measure the depth of water between 0 and 1000-foot depth, and it measures the speed and direction of water currents. The outputs of water-sensing elements are telemetered up an electric cable to indicators on the deck unit. The indicators show water speeds of 0.0064 to 3.0000 knots, and they indicate the direction of the current within porm 2.5 deg of true direction. The direction indicators are calibrated in degrees, the speed indicators in knots and fractions of a knot, and the depth indicator in feet.

No field changes in effect at time of preparation (7 February 1963).

TECHNICAL CHARACTERISTICS:

TYPE OF MEASUREMENTS: Measures depth of water, speed and directions of water currents.

INDICATOR DATA

WATER SPEEDS: 0.0064 to 3.0000 knots.

CURRENT DIRECTION: Within porm 2.5 deg of true direction.

TYPE OF INDICATOR CALIBRATION: Calibrated in degrees, the speed in knots and fractions of a knot, and depth indicator in feet.

OPERATING POWER RQMT: 115 v ac, 60 cps, single ph.

RELATION TO OTHER EQUIPMENT: None.

EQUIPMENT REQUIRED BUT NOT SUPPLIED: None.

MAJOR COMPONENTS

QTY	ITEM	STOCK NUMBERS	DIMENSIONS (INCHES)	WEIGHT (LBS)
1	Measuring Set, Water Current AN/USQ-15() consists of:			
1	Sea Unit w/speed, direction, depth sensing elements & a transmitter			
1	Cable (w/swivel) Telemetering Circuit			
1	Deck Indicating Unit (inc'l electronics parts)			

AN/USQ-15() MEASURING SET, WATER CURRENT

REFERENCE DATA AND LITERATURE:

TUBE, CRYSTAL AND/OR SEMI-CONDUCTOR DATA:

TUBES: Data not available.

CRYSTALS: Data not available.

SEMI-CONDUCTORS: Data not available.

SHIPPING DATA

PKGS	VOLUME (CU FT)	WEIGHT (LBS)
------	----------------	--------------

PROCUREMENT DATA

PROCURING SERVICE: USN

DESIGN COG: USN, BuShips

SPEC &/OR DWG:

CONTRACTOR	LOCATION	CONTRACT OR ORDER NO.	APPROX. UNIT COST
------------	----------	--------------------------	----------------------

SONAR TEST SET

AN/WQM-3

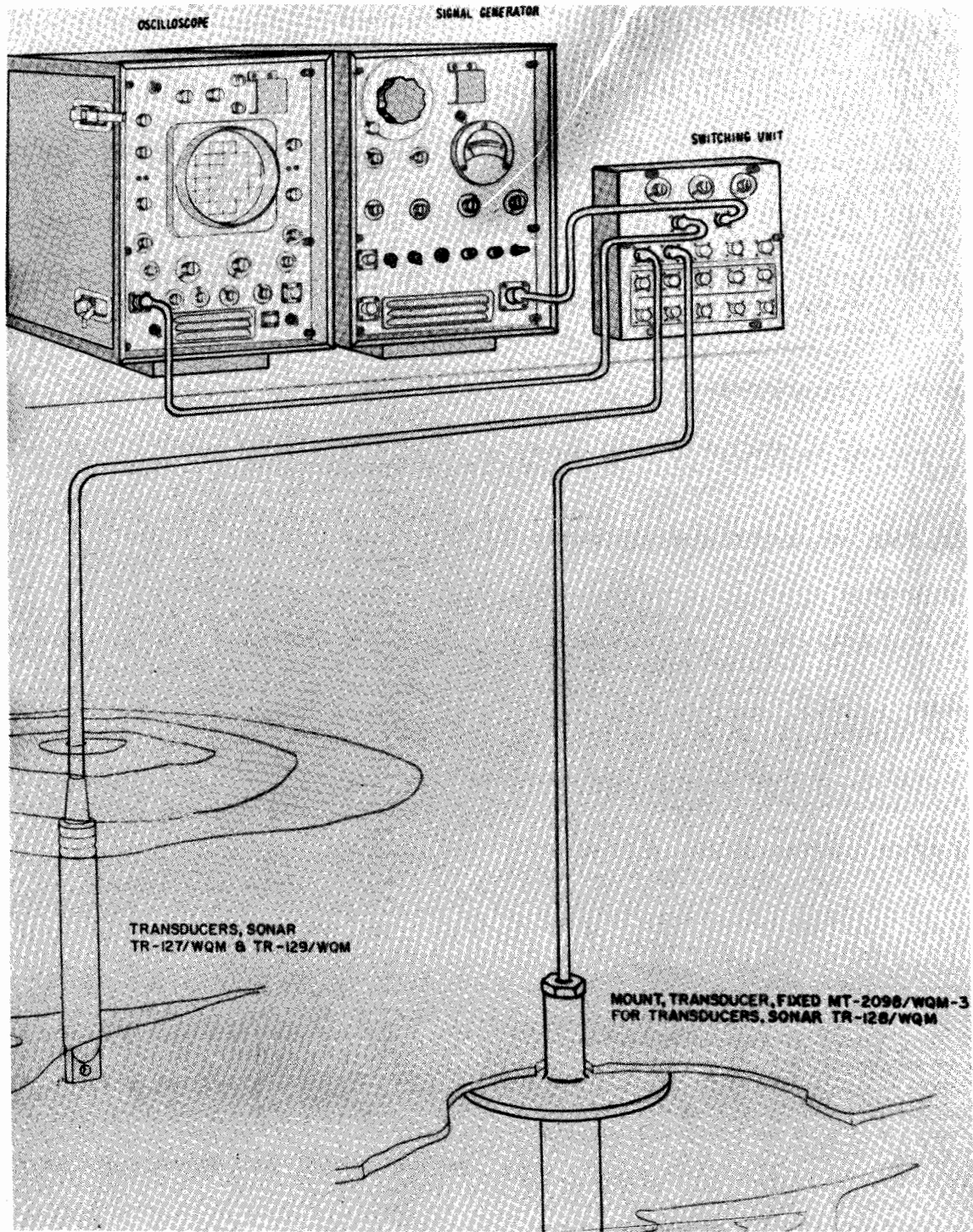

Sonar Test Set AN/WQM-3

AN/WQM-3**SONAR TEST SET****FUNCTIONAL DESCRIPTION**

Sonar Test Set AN/WQM-3 is designed for use in testing sonar equipment in order to maintain this equipment at its highest operating efficiency. The equipment acts as a known source of acoustic energy at any desired frequency between 160 cps and 160 kc per second for checking the sonar system receiving circuits. It also is capable of receiving and displaying an acoustic signal for the purpose of checking the sonar system transmitting circuits.

No field changes in effect at time of preparation (8 October 1959).

RELATION TO OTHER EQUIPMENT

This equipment is similar to Dyna-Empire Model 841.

ELECTRICAL AND MECHANICAL CHARACTERISTICS**SIGNAL GENERATOR**

FREQUENCY RANGE: 160 cps to 160 kc.
 THREE TUNING RANGES: 160 cps to 1600 cps
 1600 cps to 16 kc
 16 kc to 160 kc
 FREQUENCY ACCURACY: $\pm 1\%$.
 HARMONIC DISTORTION: 2% into matched resistive load.
 POWER OUTPUT: ± 45 db/lub at 1 yard from the transducer over the frequency range 5 kc to 160 kc.
 PULSE WIDTH - THREE RANGES: 1 to 20 milliseconds.
 10 to 200 milliseconds
 continuous wave.

PULSE WIDTH ACCURACY: $\pm 10\%$.
 TIME DELAY RANGE SCALES: 200, 500, 1,000, 2,500, 5,000, 10,000 and 15,000 yards per second.

OSCILLOSCOPE

FREQUENCY RESPONSE: ± 3 db from d-c to 300 kc for both vertical and horizontal amplifiers.
 DEFLECTION SENSITIVITY: 0.5 millivolts/cm from both vertical and horizontal amplifiers, capable of being reduced by attenuators to 50 volts/cm.
 -SWEEP RATE: 1/3 cps to 50 kc.
 CALIBRATING VOLTAGE: 1 kc square waves,

$\pm 5\%$ voltage accuracy.

TRANSDUCERS**TR127/WQM**

OPERATING FREQUENCY RANGE: 1 to 40 kc.
 FREQUENCY RESPONSE: Average value of -124 db/lv/lub ± 3 db.
 SLOPE OF FREQUENCY RESPONSE CURVE: ± 2 db/kc.
 TRANSMITTING RESPONSE: Capable of CW or pulsed level of ± 4 5 db/lub at 1 yard over its frequency range.
 VERTICAL BEAM WIDTH: 15° at -3 db points at 10 kc.
 HORIZONTAL PATTERN: Omnidirectional within ± 3 db.
 MOUNTING: Portable mounting supplied with 75 foot extension cable.

TR128/WQM

OPERATING FREQUENCY RANGE: 20 to 160 kc.
 FREQUENCY RESPONSE: Average value of -120 db/lv/lub ± 3 db.
 SLOPE OF FREQUENCY RESPONSE CURVE: ± 2 db/kc.
 TRANSMITTING RESPONSE: Capable of CW or pulsed level of ± 45 db/lub at 1 yard over its frequency range.

VERTICAL BEAM WIDTH: 15° at -3 db points at 100 kc.

HORIZONTAL PATTERN: Omnidirectional within ± 3 db.

MOUNTING: Hull mounting supplied with 75 foot extension cable.

TR129/WQM

ELECTRICAL AND ACOUSTIC: Same as TR127/WQM.

MOUNTING: Portable mounting supplied with 75 foot extension cable.

HULL MOUNT: Includes a stuffing tube to permit the transducer cable to pass through the hull.

BLISTER: Protects transducer. Attenuation of acoustic energy less than 2 db. Internal reflections less than 3%.

TEMPERATURE RANGE: 0° to 50° C.

POWER REQUIREMENTS: 103 to 126 v, 60 cy, 1 ph, 500 w.

MANUFACTURER'S OR CONTRACTOR'S DATA

Dyna-Empire Inc., Garden City, Long Island, New York.

Contract NObsr-71659, dated 21 March 1957.

UNCLASSIFIED

February 1960

Test-Combination and Group

SONAR TEST SET

AN/WQM-3

TUBE AND/OR CRYSTAL COMPLEMENT

(4) 1N198 (1) 5R4WGA (2) 1X2B
 (1) 5APQ7 (8) 6AU6WA (2) 6X4W
 (15) 12AT7WA (2) 5651 (5) 5670
 (7) 5687WA (1) 5751 (7) 5814A
 (4) 5726/6AL5W (4) 6005/6AW5W (2) 6205

Total Tubes: (65)

No Crystals used.

REFERENCE DATA AND LITERATURE

Technical Manual for TEST SET, SONAR AN/WQM-3.

TYPE CLASSIFICATION (NAVY)

DESIGN COGNIZANCE USN, BUSHIPS

PROCUREMENT COGNIZANCE SPEC: MIL-T-19361A
(SHIPS) AMEND 1

STOCK NO.

R.D.B. IDENT. NO.

SHIPPING DATA

NUMBER OF BOXES	CONTENTS AND IDENTIFICATION	VOLUME (Cu.Ft.)	OVERALL DIMENSIONS (inches)	WEIGHT PACKED (lbs.)
1	Rack, Electrical Equipment MT-2095/WQM-3V Including: Oscilloscope OS-91/WQM-3 Generator, Signal SG-326/WQM-3 Switch Box SA-486/WQM-3 Cable Assembly	9.6	21 X 24 X 33	210
1	Mount, Transducer MT-2098/WQM-3	0.37	8 X 8 X 10	10
1	Transducer, Sonar TR-127/WQM	0.22	4 X 6 X 16	10
1	Transducer, Sonar TR-128/WQM	0.22	4 X 6 X 16	10
1	Transducer, Sonar TR-129/WQM	0.22	4 X 6 X 16	10

NOTE: Depending on installation requirements, the quantities and weights may vary from those given above.

EQUIPMENT SUPPLIED DATA

QUANTITY PER EQUIPT	NAME AND NOMENCLATURE	OVERALL DIMENSIONS (inches)	WEIGHT (lbs.)
1	Sonar Test Set AN/WQM-3 Includes:		
1	Rack, Electrical Equipment MT-2095/WQM-3	1-1/2 X 19 X 24-1/8	18
1	Mount, Transducer Fixed MT-2098/WQM-3	6 dia X 3-7/8	5
1	Oscilloscope OS-91/WQM-3	13 X 18-1/2 X 23-1/4	75
1	Switch Box SA-486/WQM-3	3 X 10-1/8 X 10-5/8	5
1	Generator, Signal SG-326/WQM-3	13 X 18-1/2 X 23-1/4	75
1	Transducer, Sonar TR-127/WQM	1-1/16 dia X 9-7/8	2
1	Transducer, Sonar TR-128/WQM	1-1/16 dia X 4-13/16	2
1	Transducer, Sonar TR-129/WQM	7/8 dia X 4-1/8	2
2	Cable Assembly	120 lg	2

NOTE: Depending on installation requirements, the quantities may vary from those given above.

UNCLASSIFIED

4/10 AN/WQM-3: 3

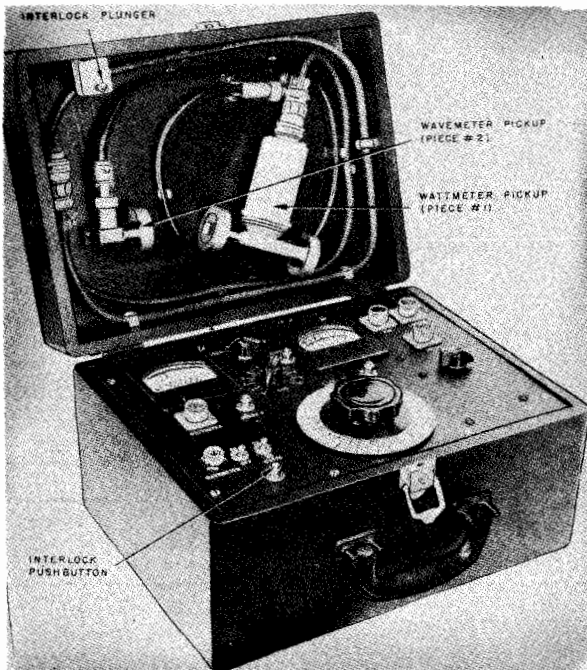

Wavemeter-Wattmeter

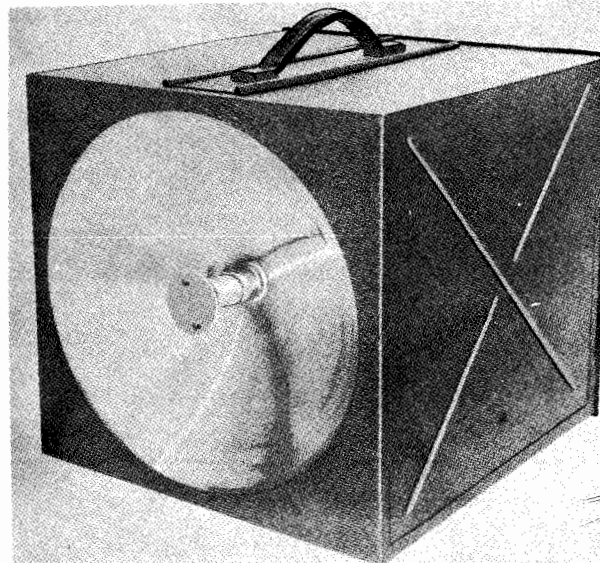

Echo Box

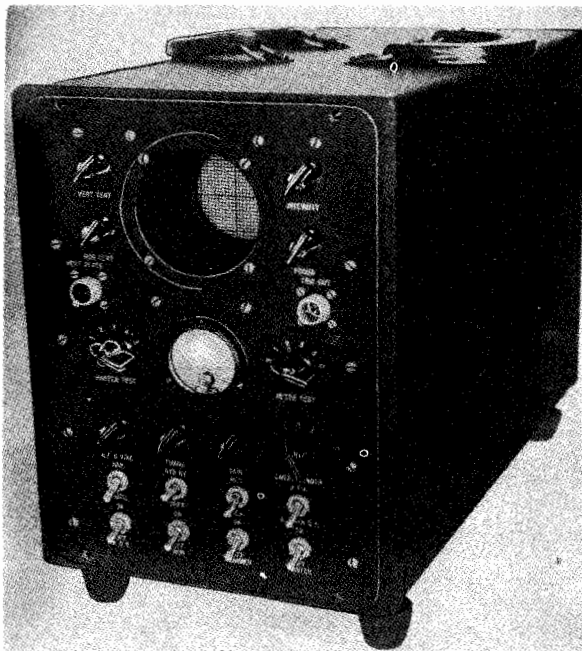

ASD-AIA Test Receiver

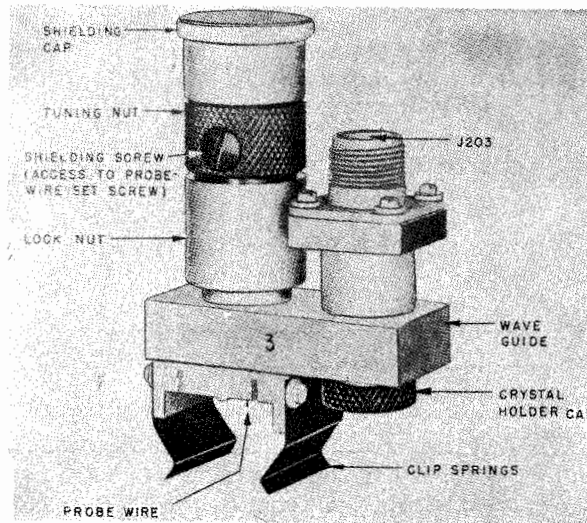

SWR Probe

Test-Equipment ASD-AIA

ASD-AIA

TEST EQUIPMENT

December 1956

FUNCTIONAL DESCRIPTION

The ASD-AIA test equipment has been designed to facilitate all the testing necessary for lining up and adjusting ASD and AIA radar systems and for locating troubles in the various units of these systems. The equipment permits testing a complete system or single units of a system either on installation in the airplane or at a repair bench. By the proper use of the test equipment on a system already installed in an airplane, any troubles can be localized to the particular unit or part of the system at fault. Each component of the equipment is compact and portable and has been so designed that a minimum of time and effort is required for set up and installation.

No field changes in effect at time of preparation (18 May 1956).

ELECTRICAL AND MECHANICAL CHARACTERISTICS

POWER SOURCE: 110 v AC, 400 to 1600 cycles, 2 amp, 24 v DC 2 amp.

POWER REPETITION RATE: 1425, 2200, 375 and 550 pulses per sec.

PRESENTATION: 3 in. cathode ray tube.

WAVEMETER-WATTMETER

RANGE: 0-25 W.

0-50 W.

ACCURACY: ±10%.

SWR METER

RANGE: 0-50 uamp DC.

DC MILLEAMMETER

RANGE: 0-1 ma.

MANUFACTURER'S OR CONTRACTOR'S DATA

Sperry Gyroscope Co., Inc.
Brooklyn, N.Y.
NXSS 17457, July 1943.

TUBE AND/OR CRYSTAL COMPLEMENT

Test Receiver

(1) 0A4-G	(1) 6AG7	(2) 6V6-GT/G
(2) 2A3	(1) 6H6	(2) 6X5-G
(1) 2X2	(1) 6L6	(2) 2050
(1) 3BP1	(2) 6SJ7	(2) 38205
(2) 5U4-G	(1) 6SL7-GT	
(9) 6AC7/1852	(5) 6SN7-GT	

Total Tubes: (35)

Wavemeter-Wattmeter

(2) 1N5-GT (1) 3Q5-GT

Total Crystals: (3)

REFERENCE DATA AND LITERATURE

NAVAER 08-58-13: Sperry Gyroscope Co., Inc.
No. 23-157 Handbook of Operating and Maintenance Instructions for ASD-AIA Test Equipment.

TYPE CLASSIFICATION
DESIGN COGNIZANCE BUSHIPS
PROCUREMENT COGNIZANCE
STOCK NO.
R.D.B. IDENT. NO.

EQUIPMENT SUPPLIED DATA

QUANTITY PER EQUIPT	NAME AND NOMENCLATURE	OVERALL DIMENSIONS (inches)	WEIGHT (lbs.)
1	60ABX Test Receiver	10-3/4 X 16-3/4 X 23-1/2	85
1	60ABW Wavemeter-Wattmeter	9-1/2 X 12-1/4 X 14	29
1	60ABS SWR Equipment	9-1/2 X 12-1/4 X 14	21
1	14AAR Echo Box	13 X 13-1/2 X 14-1/8	13
3	Cable Assemblies		

June 1957

Test-Combination and Group

TEST OSCILLATOR**BC-376-A,H,K****RELATION TO OTHER EQUIPMENT**

Similar electrically and mechanically to Test Oscillators BC-376-B, C, D, E, F and G, but its weight and size are slightly different.

Equipment Required but not Supplied: (2) Battery BA-36 (45v) and (1) Battery BA-35 (1.5v), (1) Cord CD-316, (1) Cord CD-307 or CD-307-A, (1) Headset HS-23, (1) Headset Adapter MC-385-B, (1) Screwdriver, and (1) Test Indicator BE-67 or BE-67-A.

ELECTRICAL AND MECHANICAL CHARACTERISTICS

OPERATING FREQUENCY: 75 mc (6th harmonic of crystal).

MODULATION: 400, 1300 or 3000 cps, ± 2 cps at 35%.

PEAK OUTPUT VOLTAGE: 3 v, nominal.

TEMPERATURE RANGE: -15 deg to +130 deg F.

POWER SOURCE REQUIRED: 90 v DC, 27 ma plate supply from dry cells, and 1.5 v DC, 0.25 amp filament supply from dry cell.

TUBE AND/OR CRYSTAL COMPLEMENT

(3) 1A5GT

(1) 1C5GT

Total Tubes (4)

(1) 1N34

Total Crystals (1)

REFERENCE DATA AND LITERATURE

T.O. 33A1-8-24-2: Technical Manual for Test Oscillator BC-376-A, B, C, D, E, F, G, H and K.

And Test Indicator BE-67 and BE-67-A.

TYPE CLASSIFICATION
DESIGN COGNIZANCE TASSA
PROCUREMENT COGNIZANCE
STOCK NO.
R.D.B. IDENT. NO.

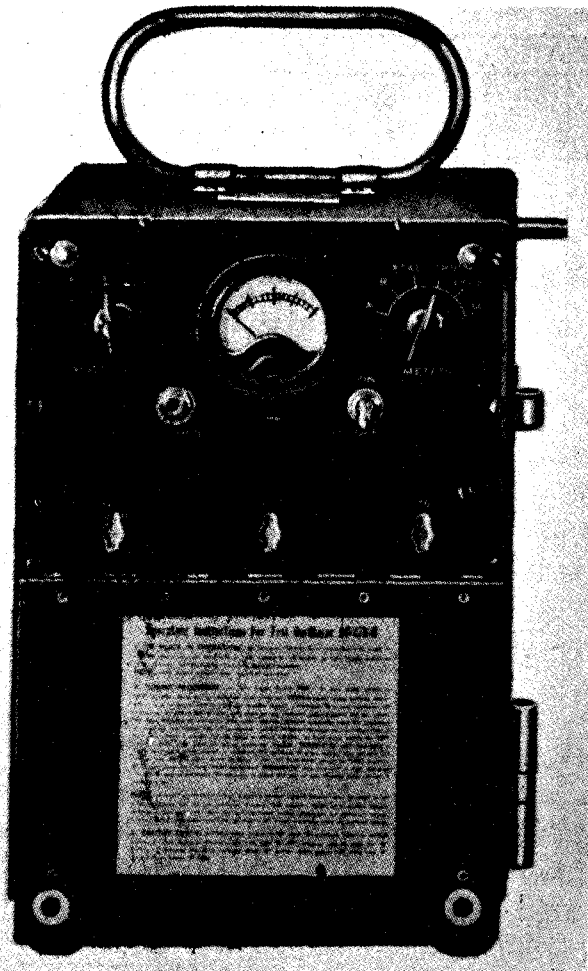

Test Oscillator BC-376-A,H,K

FUNCTIONAL DESCRIPTION

The BC-376-A, H and K are used as a portable low-power HF oscillator, or as a heterodyne frequency meter for the adjustment and tuning of marker-beacon receivers and transmitters. It operates on a crystal-controlled frequency of 75 mc, either modulated or unmodulated, and is powered by dry batteries. It may be used in conjunction with Test Indicator BE-67 or BE-67-A for adjustment and tuning of marker-beacon receivers, and is a component unit of Test Set I-76.

No field changes in effect at time of preparation (2 November 1956).

BC-376-A,H,K

TEST OSCILLATOR

EQUIPMENT SUPPLIED DATA					
QUANTITY PER EQUIPT			NAME AND NOMENCLATURE	OVERALL DIMENSIONS (inches)	WEIGHT (lbs.)
A	-H	-K			
BC-376-					
1			Test Oscillator BC-376A	7-3/4 X 9-3/16 X 12-5/16	21.5
	1		Test Oscillator BC-376H	7-3/4 X 8-9/16 X 13-3/4	17.75
		1	Test Oscillator BC-376K	7-13/16 X 9-1/4 X 15-5/8	20.25

April 1958

Test-Combination and Group

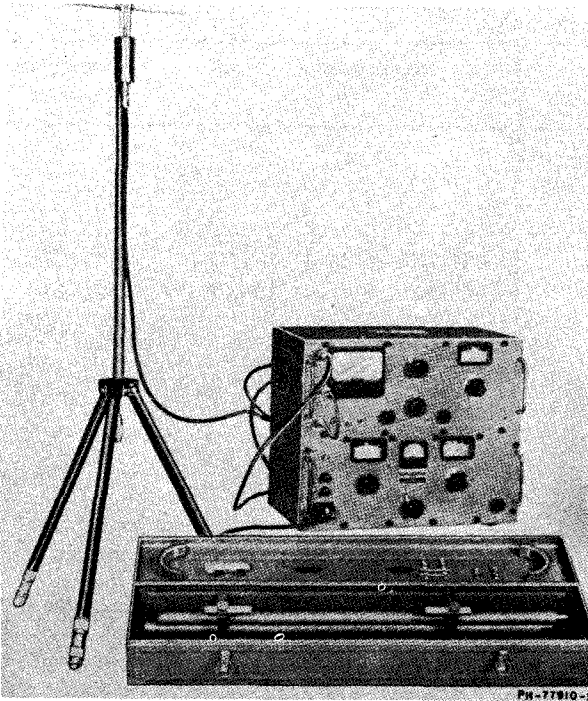
**RF TEST SET AND
FIELD INTENSITY METER****BW-3A (RCA)**

RF Test Set and Field Intensity Meter BW-3A

FUNCTIONAL DESCRIPTION

The RCA BW-3A Test Set combines in one portable unit a radio receiver of laboratory quality with metered output, and an accurately calibrated signal generator. These instruments, when used with the associated antenna assy, form a highly accurate field intensity meter which can be used for determining the RMS value of the average amplitude of the RF carrier, or the RMS value of the RF carrier at the peak of its modulation cycle.

These instruments can also be used separately for a variety of test purposes over a frequency range of 470 to 890 mc without band changing.

No field changes in effect at time of preparation (18 March 1958).

ELECTRICAL AND MECHANICAL CHARACTERISTICS**RECEIVER**

FREQUENCY RANGE: 470 to 890 mc.

SENSITIVITY (AT INPUT TERMINALS): 6 uv.

FIELD INTENSITY RANGE

AT 470 MC: 125 uv/m to 3.0 v/m.

AT 890 MC: 235 uv/m to 6.0 v/m.

MAXIMUM INPUT (AT INPUT TO PAD): 10 v.

TYPE OF CIRCUIT: Superheterodyne.

INTERMEDIATE FREQUENCY: 41.25 mc.

OUTPUT INDICATOR: Panel meter.

RECORDER OUTPUT: 1 ma.

IMAGE REJECTION: Not less than 25 db.

SIGNAL GENERATOR

FREQUENCY RANGE: 470 to 890 mc.

OUTPUT: 1.0 uv to 0.1 v.

OUTPUT IMPEDANCE: 51 ohms.

POWER REQUIREMENTS: 117 v, 50 to 60 cps, 65 W or 6 v DC, 10 amp.

MANUFACTURER'S OR CONTRACTOR'S DATA

Radio Corp of America, Engineering Products Div., Camden, N.J.

Contract NObsr 64616

TUBE AND/OR CRYSTAL COMPLEMENT

(1) 6J6	(1) OD3
(1) 6AK5	(2) 12AU7
(5) 6CB6	(1) 6SN7
(1) 6AL5	(1) 5675

Total Tubes: (13)

(2) 1N82 (2) 1N34A (1) 1N72

Total Crystals: (5)

REFERENCE DATA AND LITERATURE

NAVSHIPS 92543: Technical Manual for RCA BW-3A RF Test Set and Field Intensity Meter MI-19385.

TYPE CLASSIFICATION
DESIGN COGNIZANCE
PROCUREMENT COGNIZANCE
STOCK NO.
R.D.B. IDENT. NO.

Test-Combination and Group

BW-3A (RCA)

RF TEST SET AND
FIELD INTENSITY METER

April 1958

EQUIPMENT SUPPLIED DATA

QUANTITY PER EQUIPT	NAME AND NOMENCLATURE	OVERALL DIMENSIONS (inches)	WEIGHT (lbs.)
1	Field Intensity Meter	12-1/2 x 15-3/4 x 20	55
1	Antenna Carrying Case	6-1/2 x 7 x 28	17
1	Tripod		
1	Mast Section w/dipole support		
2	Mast Section		
1	Mast Coupling Tee		
1	AC Line Cord		
1	Battery Cable		
1	Coaxial Jumper		
2	Low Frequency Dipole Elements		
2	High Frequency Dipole Elements		
1	Antenna Cable	240 lg	
1	Attenuator 10 db.		
1	Dipole Adjusting Scale		

April 1958

RF TEST SET AND FIELD INTENSITY METER BW-7A (RCA)**ELECTRICAL AND MECHANICAL CHARACTERISTICS****RECEIVER**

FREQUENCY RANGE: 54 to 240 mc.
 SENSITIVITY (AT INPUT TERMINALS): 1.0 uv.
 FIELD STRENGTH AT 54 MC: 1.6 uv/m.
 FIELD STRENGTH AT 240 MC: 6.5 uv/m.
 MAXIMUM INPUT (AT INPUT TO PAD): 10 v.
 FIELD STRENGTH AT 54 MC: 16 v/m.
 FIELD STRENGTH AT 240 MC: 65 v/m.

TYPE: Superhetrodyne.
 INTERMEDIATE FREQUENCY: 21.4 mc.
 I. F. BANDWIDTH: 300 kc.
 OUTPUT INDICATOR: Panel Meter.
 OUTPUT RESPONSE: Average or peak.
 RECORDER OUTPUT: 1 ma.

SIGNAL GENERATOR

FREQUENCY RANGE: 54 to 240 mc.
 OUTPUT: 1.0 uv to 0.1 v.
 OUTPUT IMPEDANCE: 51 ohms.
 POWER REQUIREMENTS: 117 v, 50 to 60 cps,
 60 W or 6 v DC, 8 amp.

ANTENNA DATA

TYPE: Dipole.
 MOUNTING: Tripod.
 CONSTRUCTION: Collapsible.
 SUPPORTED HEIGHTS
 MAXIMUM: 9-1/2 ft.
 MINIMUM: 4-1/2 ft.

MANUFACTURER'S OR CONTRACTOR'S DATA

Radio Corporation of America Engineering
 Products Department, Camden, N.J.
 Contract NObsr-64616.

TUBE AND/OR CRYSTAL COMPLEMENT

(1) 6J4	(1) 5AK5
(1) 6AB4	(1) 6J6
(5) 6BH6	(1) 6AL5
(1) 6SN7	(2) 12AU7
(1) OA2	

Total Tubes: (14)

(1) 1N72	(2) 1N34A
----------	-----------

Total Crystals: (3)

REFERENCE DATA AND LITERATURE

NAVSHIPS 92542: Rf Test Set and Field Intensity Meter RCA type BW-7A (MI-19384).

TYPE CLASSIFICATION
DESIGN COGNIZANCE
PROCUREMENT COGNIZANCE
STOCK NO.
R.D.B. IDENT. NO.

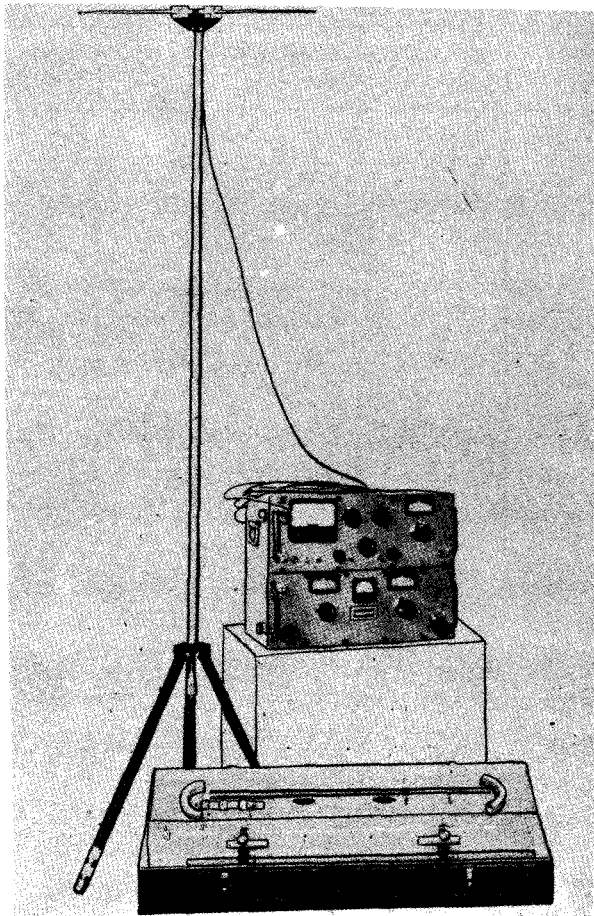

RF Test Set & Field Intensity Meter BW-7A

FUNCTIONAL DESCRIPTION

The RCA Model BW-7A Test Set combines in one portable unit a radio receiver of laboratory quality with metered output, and an accurately calibrated signal generator. These instruments, when used with the associated antenna assembly, form a highly accurate field intensity meter suitable for measuring practically all types of RF emission. This equipment may be used on AM, FM, Television, aeronautical, and commercial services within its frequency range of 54 to 240 mc. These instruments, which are capable of measuring either average or peak values of signal intensity, can be used separately for a variety of test purposes.

No field changes in effect at time of preparation (19 March 1958).

BW-7A (RCA) RF TEST SET AND FIELD INTENSITY METER

April 1958

EQUIPMENT SUPPLIED DATA

QUANTITY PER EQUIPT	NAME AND NOMENCLATURE	OVERALL DIMENSIONS (inches)	WEIGHT (lbs.)
1	Field Intensity Meter with:	11-3/4 X 15-1/4 X 20	56
1	A.C. Line Cord		
1	Battery Cable		
1	Coaxial Lead		
1	Antenna Carrying Case containing:		
	Tripod	6-1/2 X 7 X 28	
	Mast Section with Dipole Support		
	Mast Section and Tee		
	Extension Mast Section		
2	Low Frequency Dipole Elements	420 lg	
2	High Frequency Dipole Elements		
1	Antenna Cable		
1	Attenuator, 40 db		
1	Technical Manual		

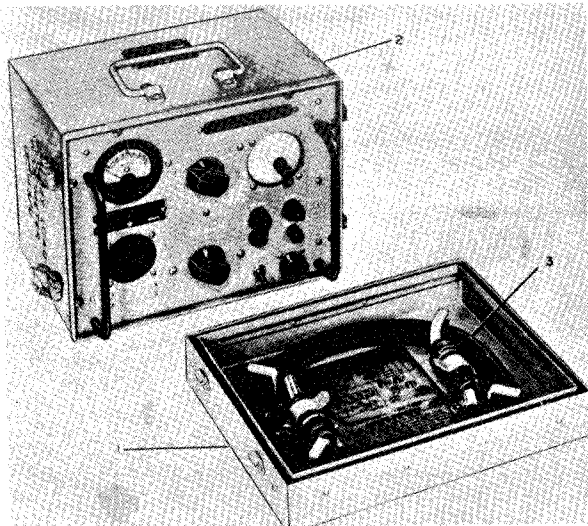
DUMMY LOAD WATTMETER**DA-43/U**

Dummy Load Wattmeter DA-43/U

200, 300, 400 uuf.

RF POWER DISSIPATION: 100 W max.

CALIBRATION ACCURACY: $\pm 15\%$.

CAPACITANCES: Four 100 uuf capacitor, 1500 v rating.

MANUFACTURER'S OR CONTRACTOR'S DATA

Control Electronics Co. Inc., Huntington Station, New York.

Model RFW-220.

Contract NOas-53-454a.

Melstrom Mfg Corp., Perth Amboy, N. J.

Contract N383s-12275A.

TUBE AND/OR CRYSTAL COMPLEMENT

No Electron Tubes or Crystals used.

FUNCTIONAL DESCRIPTION

Dummy Load Wattmeter DA-43/U is used as a substitute load for radio transmitters and other sources of rf power, operating in the frequency range of 200 kc to 20 mc. The equipment is most commonly used in place of the antenna, during servicing of radio transmitters. Relatively little radiation will occur during testing of the transmitter when the dummy load wattmeter is used as the load.

No field changes in effect at time of preparation (23 November 1959).

ELECTRICAL AND MECHANICAL CHARACTERISTICS

FREQUENCY RANGE: 200 kc to 20 mc.

IMPEDANCES: 4, 6, 10, 20, 40 ohms.

SERIES CAPACITY: Direct connection, or 100,

REFERENCE DATA AND LITERATURE

AN 16-35DA43-11: Handbook Operation Instructions for DUMMY LOAD WATTMETER DA-43/U.

AN 16-35DA43-12: Handbook Service Instructions for DUMMY LOAD WATTMETER DA-43/U.

AN 16-35DA43-13: Handbook Overhaul Instructions for DUMMY LOAD WATTMETER DA-43/U.

AN 16-35DA43-14: Illustrated Parts Breakdown for DUMMY LOAD WATTMETER DA-43/U.

TYPE CLASSIFICATION (NAVY)

DESIGN COGNIZANCE USN, BUAER

PROCUREMENT COGNIZANCE SPEC: MIL-D-7166A

STOCK NO.

R.D.B. IDENT. NO.

EQUIPMENT SUPPLIED DATA

QUANTITY PER EQUIPT	NAME AND NOMENCLATURE	OVERALL DIMENSIONS (inches)	WEIGHT (lbs.)
1	Dummy Load Wattmeter DA-43/U	9-5/8 X 9-3/4 X 12-1/2	15-1/2
1	Power Cable	180 lg	1-1/8
1	Allen Wrench	5/64 X 5/64 X 1-7/8	

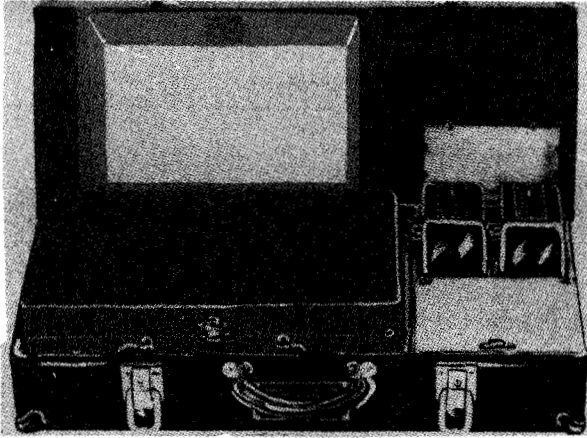
TEST SETS**I-56-C, -D, -J**

Test Sets I-56-C, -D, -J

FUNCTIONAL DESCRIPTION

The I-56-C, -D, -J are electrical instruments designed for the maintenance and repair of radio equipment. The test set affords a rapid and accurate means of locating trouble. The test set is used to analyze radio troubles, to test vacuum tubes and pilot lamps, to measure voltage, current, resistance, and audio output voltage; and to make capacity and free point measurements.

The Test Set I-56-D differs from the Test Sets I-56-C and I-56-J in the type of components.

No field changes in effect at time of preparation (18 July 1957).

ELECTRICAL AND MECHANICAL CHARACTERISTICS

METER: 100 ua full scale deflection.

SOCKET TYPES PROVIDED: 4-prong, 5-prong, 6-prong, combination large and small 7-prong, 8-prong octal, 8-prong loctal, 5-prong bantam junior, 7-prong miniature and 7-prong midget tubes.

RANGES

DC VOLTS: 10, 50, 250, 500 and 1000 v.

AC VOLTS: 10, 50, 250, 500 and 1000 v.

DC CURRENT: 1 ma, 10 ma, 50 ma and 250 ma.

RESISTANCE: 0 to 500 ohms, 0 to 150000 ohms, 0 to 1.5 megs and 0 to 15 megs.

CAPACITANCE: 0.001 uf to 0.1 uf, 0.1 uf to 1 uf, 1 uf to 10 uf.

SENSITIVITY

DC VOLTS: 10000 ohms per volt.

AC VOLTS: 2000 ohms per volt.

POWER SOURCE REQUIRED: 105 to 130 v, 60 cps, single ph.

TUBE AND/OR CRYSTAL COMPLEMENT

No Electron Tubes.

REFERENCE DATA AND LITERATURE

TM11-303; Technical Manual for Test Sets I-56-C, -D, -H, -J.

TYPE CLASSIFICATION
DESIGN COGNIZANCE TASSA
PROCUREMENT COGNIZANCE
STOCK NO.
R.D.B. IDENT. NO.

SHIPPING DATA

NUMBER OF BOXES	CONTENTS AND IDENTIFICATION	VOLUME (Cu.Ft.)	OVERALL DIMENSIONS (inches)	WEIGHT PACKED (lbs.)
1	Test Set I-56-C or I-56-D or I-56-J			

EQUIPMENT SUPPLIED DATA

QUANTITY PER EQUIPT	NAME AND NOMENCLATURE	OVERALL DIMENSIONS (inches)	WEIGHT (lbs.)
*1	Carrying Case, Steel, w/6 keys	6-3/4 X 8-7/8 X 23-9/16	17.5
**1	Carrying Case, Steel, w/6 keys	7 X 9 X 23-5/8	16.7
*1	Combination Tester, Model 104	5-1/2 X 7-1/2 X 15-1/2	17.25
**1	Combination Tester, Model 1183-SC	5-5/8 X 8-5/8 X 15	15.7

Test-Combination and Group

January 1958

I-56-C, -D, -J

TEST SETS

EQUIPMENT SUPPLIED DATA

QUANTITY PER EQUIPT	NAME AND NOMENCLATURE	OVERALL DIMENSIONS (inches)	WEIGHT (lbs.)
*1	Volt-Ohm Tester, Model 102	3 X 3-1/16 X 6-1/8	2.5
**1	Volt-Ohm Tester, Model 666-SC	3 X 3 X 5-7/8	1.6
*1	Output Meter, Model 103	3 X 3-1/16 X 6-1/8	1.75
**1	Output Meter, Model 650-SC	3 X 3 X 5-7/8	1.6
***1	Set of adapter plugs c/o	3/4 X 4 X 6-1/4	0.40
	(1) 4-prong		
	(1) 5-prong		
	(1) 6-prong		
	(1) small 7-prong		
	(1) large 7-prong		
***	Octal and loctal for freepoint testing		
***1	BN adapter		0.40
***3	Pair, Test Leads		
***2	Alligator, Slip-on Clips		0.30
**1	Test lead for tube tests		
1	Technical Manual		

NOTES: *Test Set I-56-D only
 **Test Set I-56-C and I-56-J
 ***Test Set I-56-D, I-56-C or I-56-J

UNCLASSIFIED

January 1958

Test-Combination and Group

TEST SET

I-56-L

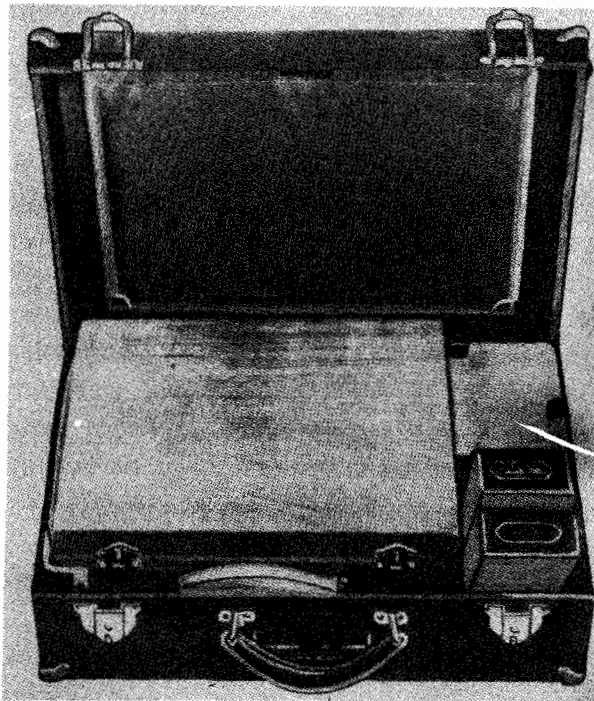

Test Set I-56-L

voltage, current, capacity and resistance data on various radio sets, provides for the rapid testing of voltage and continuity, permits the taking of output readings during the alignment of radio sets.

No field changes in effect at time of preparation (23 July 1957).

ELECTRICAL AND MECHANICAL CHARACTERISTICS

RANGES

DC VOLTS: 0 to 7.5, 0 to 15, 0 to 50, 0 to 150, 0 to 500, 0 to 1000 v.

AC VOLTS: 0 to 2, 0 to 7.5, 0 to 15, 0 to 50, 0 to 150, 0 to 500, 0 to 1000 v.

DC CURRENT: 0 to 1, 0 to 10, 0 to 100, 0 to 500 ma.

RESISTANCE: 0 to 10000, 0 to 100000, 0 to 1000000, 0 to 10000000 ohms.

CAPACITY: 0 to 0.1, 0 to 1, 0 to 10, 0 to 100 uf.

MANUFACTURER'S OR CONTRACTOR'S DATA

Weston Electrical Instrument Corp.
Contract Order No. 10512-Phila-42.

TUBE AND/OR CRYSTAL COMPLEMENT

(1) 71-A
Total Tubes: (1)

REFERENCE DATA AND LITERATURE

TM11-321: Technical Manual for Test Set I-56-E.

TYPE CLASSIFICATION
DESIGN COGNIZANCE TASSA
PROCUREMENT COGNIZANCE
STOCK NO.
R.D.B. IDENT. NO.

FUNCTIONAL DESCRIPTION

The I-56-L consists of a set of instruments and auxiliary equipment which is necessary or desirable, to properly service radio equipment now in use by the various branches of the service.

The test set provides facilities for testing receiving type vacuum tubes as well as functioning as an analyzer for obtaining the

EQUIPMENT SUPPLIED DATA

QUANTITY PER EQUIPT	NAME AND NOMENCLATURE	OVERALL DIMENSIONS (inches)	WEIGHT (lbs.)
1	Test Set I-56-L c/o	6-7/8 X 13-3/4 X 19-3/4	41
	(1) Analyzer Model 774 type 5	5-7/8 X 11-3/4 X 14	17
	(1) Vdt-Ohmmeter Model 564 type 3C	2-1/2 X 3-5/8 X 5-1/2	1-3/4
	(1) Output Meter Model 571 Type 3A	2-7/8 X 3-5/8 X 5-1/2	1-1/2

UNCLASSIFIED

December 1956

TEST EQUIPMENT

IE-17,-D,-E

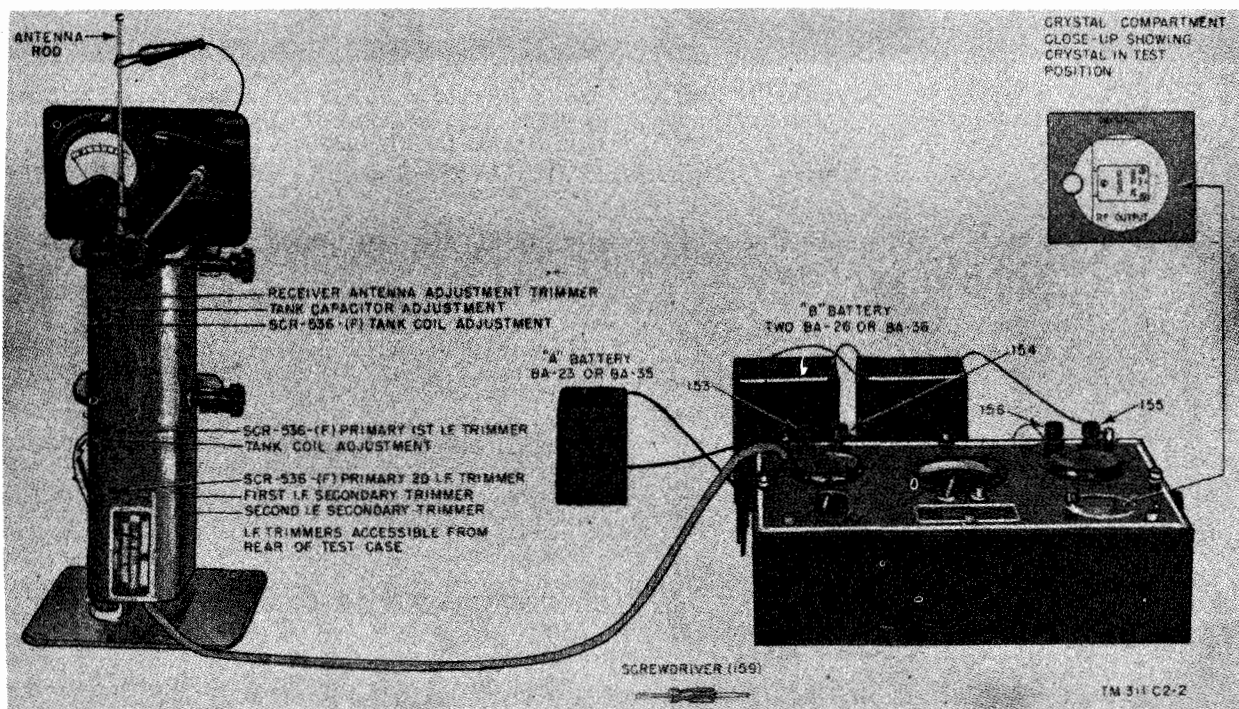

Test Equipment IE-17-E, Set up with test unit I-135-F

FUNCTIONAL DESCRIPTION

The IE-17, IE-17-D or IE-17-E is used with Radio Set SCR-585 () for testing and alignment of Radio Set SCR-536-(), testing of the crystals and for voltage measurement of batteries used in the SCR-536-().

Test Unit I-135-E of this equipment contains a microphone, earphone receiver, RF Oscillator, AF Oscillator and a crystal compartment along with various sockets and terminals.

No field changes in effect at time of preparation (17 July 1956).

RELATION TO OTHER EQUIPMENT

Equipment Required but Not Supplied: (1) Battery BA-23 or BA-35 (2) Batteries BA-26 or BA-36. For emergency operation BA-37 or BA-38 may be used.

ELECTRICAL AND MECHANICAL CHARACTERISTICS

FREQUENCY OF AF SIGNAL: 1000 cps.
MEASURING RANGES: 0 to 3 v DC, 0 to 600 ma

UNCLASSIFIED

DC, 0 to 150 v DC, 0 to 60 ma DC, 0 to 15 ma DC, 0 to 60 v AC, 0 to 1.5 ma DC.

POWER SOURCE REQUIRED: (1) 1.5 v battery BA-23 or BA-35, (2) 90 to 105 v battery BA-26 or BA-36. For emergency operation battery BA-37 or BA-38 maybe used.

MANUFACTURER'S OR CONTRACTOR'S DATA

Triumph Mfg. Co., Chicago, Illinois
IE-17 Contract 7641-Phila-44, No dates.
IE-17-D Contract 1345-WF-43, No dates.
IE-17-E Contract 9015-WF-43, No dates.
DP-43-MR-168 Contract 29056-Phila-43, No dates.

Approximate Cost: \$500.00 IE-17 with equipment spares.

Approximate Cost: \$150.00 IE-17-E with equipment spares.

Approximate Cost: \$150.00 IE-17-D with equipment spares.

TUBE AND/OR CRYSTAL COMPLEMENT

(1) 1T4 (1) 3S4

Total Tubes: (2)

IE-17,-D,-E

TEST EQUIPMENT

December 1956

REFERENCE DATA AND LITERATURE

Vol III U.S. Marine Corp. Electronics Catalog.
 Preliminary Instructions for Test Equipment
 IE-17-D.
 TM 11-311 War Dept. Technical Manual for Test
 Equipment IE-17-E.

TYPE CLASSIFICATION
DESIGN COGNIZANCE TASSA
PROCUREMENT COGNIZANCE TASSA
STOCK NO.
R.D.B. IDENT. NO.

SHIPPING DATA

NUMBER OF BOXES	CONTENTS AND IDENTIFICATION	VOLUME (Cu.Ft.)	OVERALL DIMENSIONS (inches)	WEIGHT PACKED (lbs.)
1	Test Equipment IE-17 or	3.5		25
1	Test Equipment IE-17-D or			
1	Test Equipment IE-17-E	2.7		47

EQUIPMENT SUPPLIED DATA

QUANTITY PER EQUIPT	NAME AND NOMENCLATURE	OVERALL DIMENSIONS (inches)	WEIGHT (lbs.)
1	Antenna-A-82 (Artificial)	4-1/2 X 6-1/2 X 13	1.4
1	Test Case CS-81E	3-3/4 X 4-3/8 X 12-3/4	1.8
2	Technical Manual TM 11-311		
1	Test Stand FT-252-E	7 X 7 X 13-1/4	3.1
1	Test Unit I-135 (*)	6 X 9-1/4 X 14-5/8	13.7

December 1956

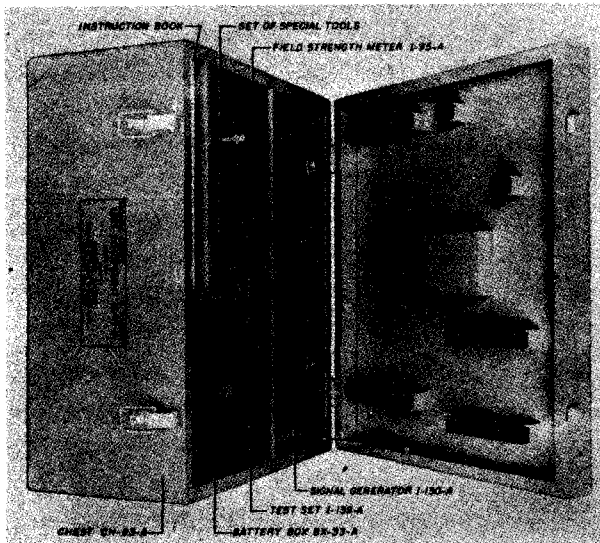
TEST EQUIPMENT**IE-19-A**

Test Equipment IE-19-A

ELECTRICAL AND MECHANICAL CHARACTERISTICS

FREQUENCY RANGE: 100 to 156 mc.
 MODULATION FREQUENCY: 1000 cps.
 OUTPUT VOLTAGE: 0 to 5000 uv, variable.
 FIELD STRENGTH METER: 0 to 1 ma.
 POWER REQUIREMENTS: Batteries.

MANUFACTURER'S OR CONTRACTOR'S DATA

Approximate Cost: \$300.00 with equipment
 spares.

TUBE AND/OR CRYSTAL COMPLEMENT

(2) 9002 (1) 1S5 (3) 9003

Total Tubes: (6)

REFERENCE DATA AND LITERATURE

T.O. 08-10-111: Technical Manual for Operation
 and Maintenance of Test Equipment
 IE-19-A.

FUNCTIONAL DESCRIPTION

The IE-19-A is a combination test set used for bench and field testing of airborne communications equipment. It provides the necessary signals and measuring devices to align and to test transmitter and receiver units. The IE-19-A is used with Radio Sets SCR-522A, 522-T2, 542-A and 542-T2.

No field changes in effect at time of preparation (29 June 1956).

RELATION TO OTHER EQUIPMENT

Equipment Required but not Supplied: (5)
 Batteries BA-23, (8) Batteries BA-2.

TYPE CLASSIFICATION
 DESIGN COGNIZANCE TASSA
 PROCUREMENT COGNIZANCE
 STOCK NO.
 R.D.B. IDENT. NO.

EQUIPMENT SUPPLIED DATA

QUANTITY PER EQUIPT	NAME AND NOMENCLATURE	OVERALL DIMENSIONS (inches)	WEIGHT (lbs.)
1	Signal Generator I-130-A	7-9/16 x 9-3/4 x 19	27.2
1	Cord CD-477	120 lg.	1.4
1	Battery Box BX-33-A	8-1/2 x 8-11/16 x 9-3/8	9.5
1	Test Set I-139-A	3 x 4 x 4	1.1
1	Field Strength Meter I-95-A	7-1/4 x 7-5/16 x 8-1/2	11.0
1	Chest CH-93-A	11 x 19-1/2 x 22-3/4	48.5
1	Tool Set, Special		
1	Instruction Book		

TEST EQUIPMENT

IE-35-A

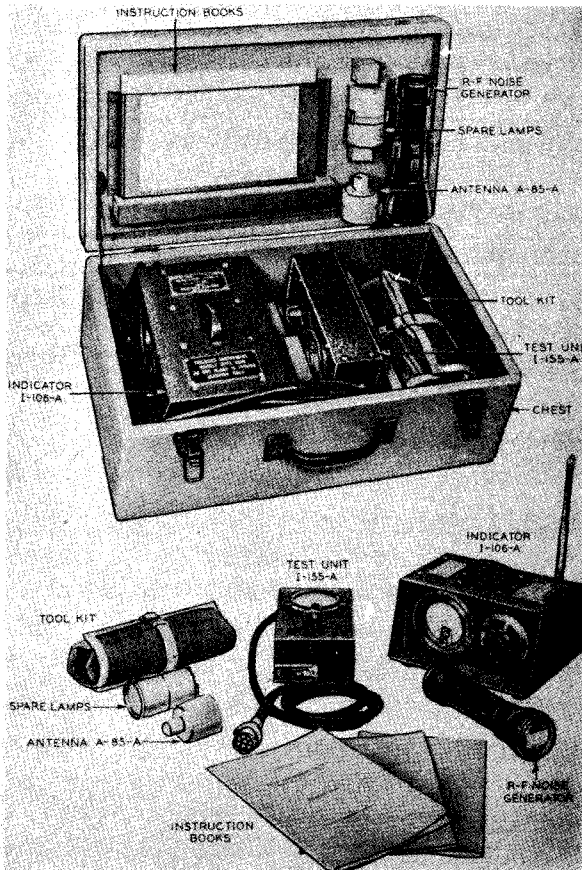

Test Equipment IE-35-A

FUNCTIONAL DESCRIPTION

The IE-35-A is a portable universal test set used for checking radio transmitters and receivers in the 100 to 156 megacycle frequency range, and some medium frequency equipments, without removing them from aircraft. It is designed for tuning and maintenance of Radio Transmitter T-23/ARC-5 and Radio Receiver R-28/ARC-5. It is also used for field maintenance and tuning of Radio Transmitter BC-950-A, Radio Receiver BC-942-A, and components of Radio Set SCR-274-N.

It contains a buzzer to provide a quick check of receivers, and indicators are provided for the tuning of transmitters.

No field changes in effect at time of preparation (21 April 1958).

UNCLASSIFIED

RELATION TO OTHER EQUIPMENT

Equipment Required but not Supplied: (2) Battery BA-30.

ELECTRICAL AND MECHANICAL CHARACTERISTICS

RF NOISE GENERATOR: Used as source of noise for adjusting or tuning a VHF radio receiver.

INDICATOR: Detects radiation from VHF antenna.

ANTENNA: Comprises 3 lamps in parallel, provides loads of approx 50 ohms at 12 W.

TEST UNIT: Incorporates 0 to 100 scale DC meter, 1 ma full scale deflection, and 7 position rotary switch.

POWER REQUIREMENTS: (2) Batteries BA-30 for RF Noise Generator.

MANUFACTURER'S OR CONTRACTOR'S DATA

Western Electric Company, New York, N.Y.

TUBE AND/OR CRYSTAL COMPLEMENT

No Electron Tubes used.

(1) D-164389(WECO)
Total Crystals: (1)

REFERENCE DATA AND LITERATURE

Technical Manual for Test Equipment IE-35-A.

TYPE CLASSIFICATION
DESIGN COGNIZANCE TASSA
PROCUREMENT COGNIZANCE
STOCK NO.
R.D.B. IDENT. NO.

IE-35-A

TEST EQUIPMENT

SHIPPING DATA

NUMBER OF BOXES	CONTENTS AND IDENTIFICATION	VOLUME (Cu.Ft.)	OVERALL DIMENSIONS (inches)	WEIGHT PACKED (lbs.)
1	Test Equipment IE-35-A	1.0		31.2

EQUIPMENT SUPPLIED DATA

QUANTITY PER EQUIPT	NAME AND NOMENCLATURE	OVERALL DIMENSIONS (inches)	WEIGHT (lbs.)
1	Antenna A-85-A		
1	RF Noise Generator		
1	Indicator I-106-A		
1	Test Unit I-155-A		
1	Tool Kit		
1	Carrying Chest CH-130-A		
3	Technical Manual		

March 1957

TEST EQUIPMENT

IE-36

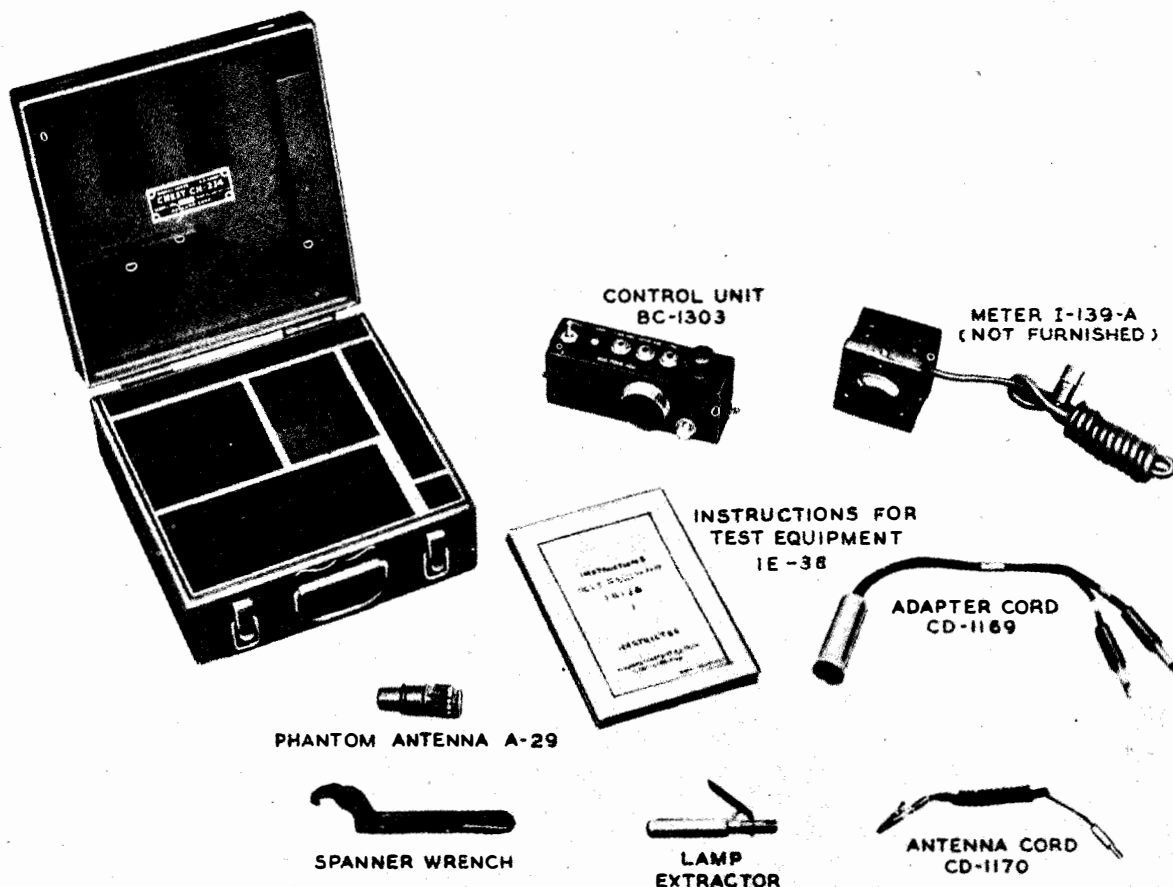
*Test Equipment IE-36***FUNCTIONAL DESCRIPTION**

The IE-36 is used to make field tests of Radio Sets SCR-522-A and SCR-542-A. It provides a means of trouble shooting these radio sets at the point of installation. Headset and microphone connections eliminate the necessity of using control boxes and jack boxes. This equipment permits a test of the functioning of the channel selector circuits in the transmitter and receiver, a test of the starting and stopping mechanisms of Radio Transmitter BC-625-A and Radio Receiver BC-624-A, a test of the receiver-transmitter remote switching functions, a test of contactor operation in the transmitter, a qualitative test of proper modulation in the transmitter and a test of the relative sensitivity of the radio receiver. Only relative power output and index of modulation is provided as indicated by the mode of operation.

of the phantom antenna lamp. The equipment is not intended to furnish transmitter field strength indications.

No field changes in effect at time of preparation (18 July 1956).

RELATION TO OTHER EQUIPMENT

Equipment Required but not Supplied: (1) Test Set I-139-A, (1) carbon microphone T-17, (1) magnetic microphone T-44, (1) headset, (1) Bristol No. 6 Set Screw Wrench.

ELECTRICAL AND MECHANICAL CHARACTERISTICS

FREQUENCY RANGE: 100 to 156 mc.
DATA INDICATORS: (1) 0 to 1 ma DC meter (Test Set I-139-A; not supplied): Pilot lamp mounted on Phantom Antenna.

IE-36

TEST EQUIPMENT

March 1957

CONTROLS AND OUTLETS: "T-R-REM" toggle, switch, "ANT" pin jack, "CAR-MIC" jack, "MAG-MIC" jack, "TEL" jack, combined "OFF ABCD" band selector Knob switch, hole marked "BUZ TONE ADJ", "CONT ON-OFF" toggle switch and a "SIG GEN ON-OFF" toggle switch.

POWER SOURCE REQUIRED: None.

TUBE AND/OR CRYSTAL COMPLEMENT

No Electron Tubes.

REFERENCE DATA AND LITERATURE

ANOR-401F36-2: Handbook of Maintenance Instructions for Test Equipment IF-36.
Instructions for Test Equipment IF-36.

MANUFACTURER'S OR CONTRACTOR'S DATA

Approximate Cost: \$200.00 with equipment spares-

TYPE CLASSIFICATION
DESIGN COGNIZANCE BUAER
PROCUREMENT COGNIZANCE BUAER
STOCK NO.
R.D.B. IDENT. NO.

EQUIPMENT SUPPLIED DATA

QUANTITY PER EQUIPT	NAME AND NOMENCLATURE	OVERALL DIMENSIONS (inches)	WEIGHT (lbs.)
1	Chest CH-234	4 X 9-7/8 X 10	4.5
1	Control Unit BC-1303	2-7/16 X 3-1/4 X 7-1/4	1.6
1	Phantom Antenna A-29	1-1/4 X 2-11/16	0.1
1	Cord (Adapter) CD-1169	15-3/4	0.3
1	Cord (Antenna) CD-1170	38-3/4	0.125
1	Wrench Spanner, Type 471	6	0.3
1	Lamp Extractor	4	0.3

UNCLASSIFIED

January 1958

Test-Combination and Group

TEST EQUIPMENT

IE-46-B

FUNCTIONAL DESCRIPTION

The IE-46-B is designed to check, test and set certain radio equipment such as Radio Set SCR-595-A or Radio Set SCR-595-AZ, Radio Set SCR-695-A or Radio Set SCR-695-AZ, Radio Set SCR-729-A, Beacon Transmitter Receiver AN/TPN-1, Beacon Transmitter Receiver AN/PPN-1 and Beacon Transmitter Receiver AN/APN-2.

The Test Equipment is composed of a frequency meter, a radio receiver and a signal generator. The frequency meter is used for determining and setting the receiver and signal generator at the frequency at which the equipment under test operates; the radio receiver is used for detecting the signal sent out by the equipment under test; while the signal generator is used to send a signal of a known frequency to the radio equipment under test.

No field changes in effect at time of preparation (26 July 1957).

ELECTRICAL AND MECHANICAL CHARACTERISTICS

FREQUENCY METER BC-906-D

POWER SOURCE REQUIRED: 45 v and 1.5 v DC.
RADIO RECEIVER BC-1066-B.

NUMBER OF BANDS: 2
POWER SOURCE REQUIRED: 45 v and 1.5 v DC.
SIGNAL GENERATOR I-196-B.

POWER SOURCE REQUIRED: 45 v and 1.5 v DC.

TUBE AND/OR CRYSTAL COMPLEMENT

(1) 185 (1) 108GT (3) 957
Total Tubes: (5)

REFERENCE DATA AND LITERATURE

T.O. No. 08-10-154, Technical Manual for Test Equipment IE-46-B.

TYPE CLASSIFICATION
DESIGN COGNIZANCE USAF
PROCUREMENT COGNIZANCE
STOCK NO.
R.D.B. IDENT. NO.

EQUIPMENT SUPPLIED DATA

QUANTITY PER EQUIPT	NAME AND NOMENCLATURE	OVERALL DIMENSIONS (inches)	WEIGHT (lbs.)
1	Frequency Meter BC-906-D c/o (1) Antenna (extendable-type) (1) Battery BA-35-A (or subsequent production) (1.5 v) (1) Battery BA-53-A (45 v) (1) Chart (calibration)	6-30/32 X 8-23/32 X 12-15/64 20 X 9.218 2-5/8 X 2-5/8 X 3-7/8 1-7/8 X 3 X 4-1/2 5-1/2 X 5-5/8	17.8
1	Radio Receiver BC-1066-B c/o (2) Battery BA-35-A (1.5 v) (4) Battery BA-53-A (45 v)	2-5/8 X 2-5/8 X 3-7/8 1-7/8 X 3 X 4-1/2	17.5
1	Signal Generator I-196-B c/o (2) Battery BA-35-A (1.5 v) (4) Battery BA-53-A (45 v)	2-5/8 X 2-5/8 X 3-7/8 1-7/8 X 3 X 4-1/2	16.0

UNCLASSIFIED

April 1958

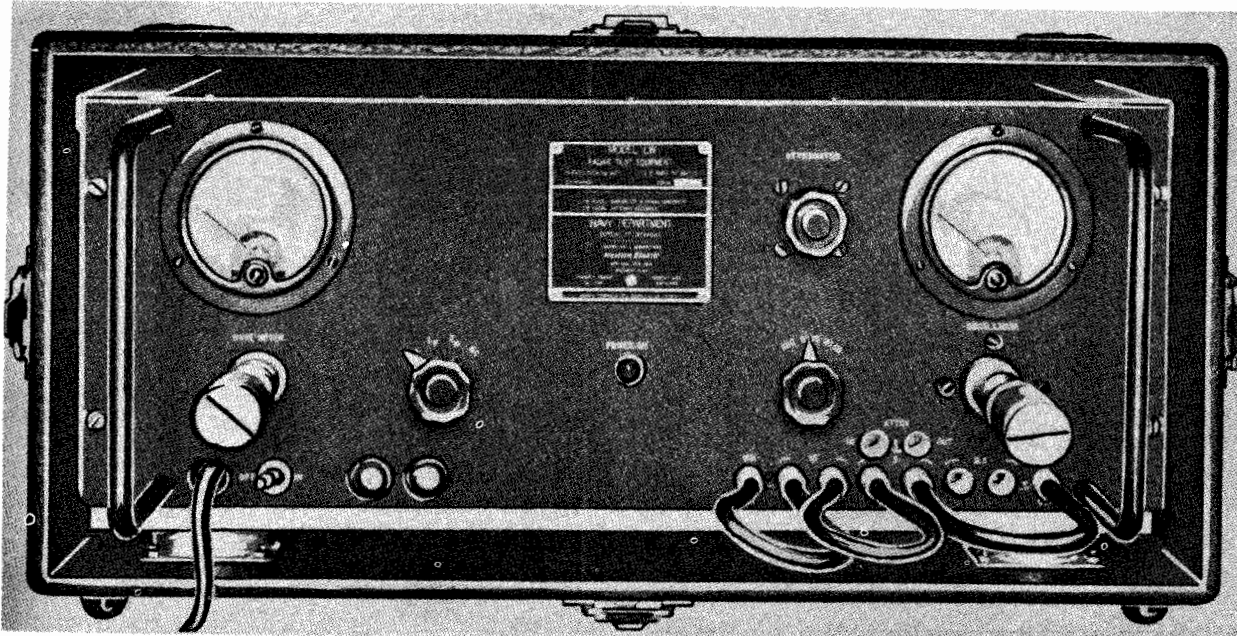
RADAR TEST EQUIPMENT**LW***Radar Test Equipment LW***FUNCTIONAL DESCRIPTION**

The LW is used to check the adjustment and operation of the MK 3 and MK 4 Detecting and Ranging Radar Equipments. Its primary purpose is to make available a suitable signal for tuning the radar receiver to its particular radar transmitter. If it is necessary to change the operating frequency of the radar equipment when no fixed signal is available this test equipment can be used to completely readjust the radar equipment including the duplexing and receiver protector units as well as the receiver. Another function is to monitor the power radiated from the radar equipment.

No field changes in effect at time of preparation (10 April 1958).

ELECTRICAL AND MECHANICAL CHARACTERISTICS**WAVEMETER AND SIGNAL GENERATOR**

FREQUENCY RANGE: 680 to 720 mc.

ATTENUATION: 25 to 60 db.

ACCURACY: ± 3 mc relative, ± 1 mc absolute.

POWER REQUIREMENTS: 110 to 120 v, 60 cps, single phase, 0.4 amp.

ANTENNA ASSEMBLY

TYPE: Dipole.

FEED: Coaxial line.

MANUFACTURER'S OR CONTRACTOR'S DATA

Western Electric Co Inc, New York, N.Y.

Contract NOs-551A, dated 6 May 1942.

Approximate Cost: \$400.00 with equipment spares.

TUBE AND/OR CRYSTAL COMPLEMENT

(1) 5W4 (1) 703A (1) 704A

Total Tubes: (3)

No Crystals used.

REFERENCE DATA AND LITERATURE

NAVSHIPS 95119: Technical Manual for Radar Test Equipment Navy Model LW.

<p>TYPE CLASSIFICATION DESIGN COGNIZANCE BUORD PROCUREMENT COGNIZANCE STOCK NO. R.D.B. IDENT. NO.</p>

April 1958

Test-Combination and Group

LW

RADAR TEST EQUIPMENT

EQUIPMENT SUPPLIED DATA

QUANTITY PER EQUIPT	NAME AND NOMENCLATURE	OVERALL DIMENSIONS (inches)	WEIGHT (lbs.)
1	Wavemeter and Signal Generator NT-60AAL	10-1/2 x 16-1/2 x 21	60
7	Coaxial Cables		
1	Antenna Assembly NT-66ABL with Accessories		
4	Spare Rectifier Tubes		

RADAR TEST EQUIPMENT

LZ

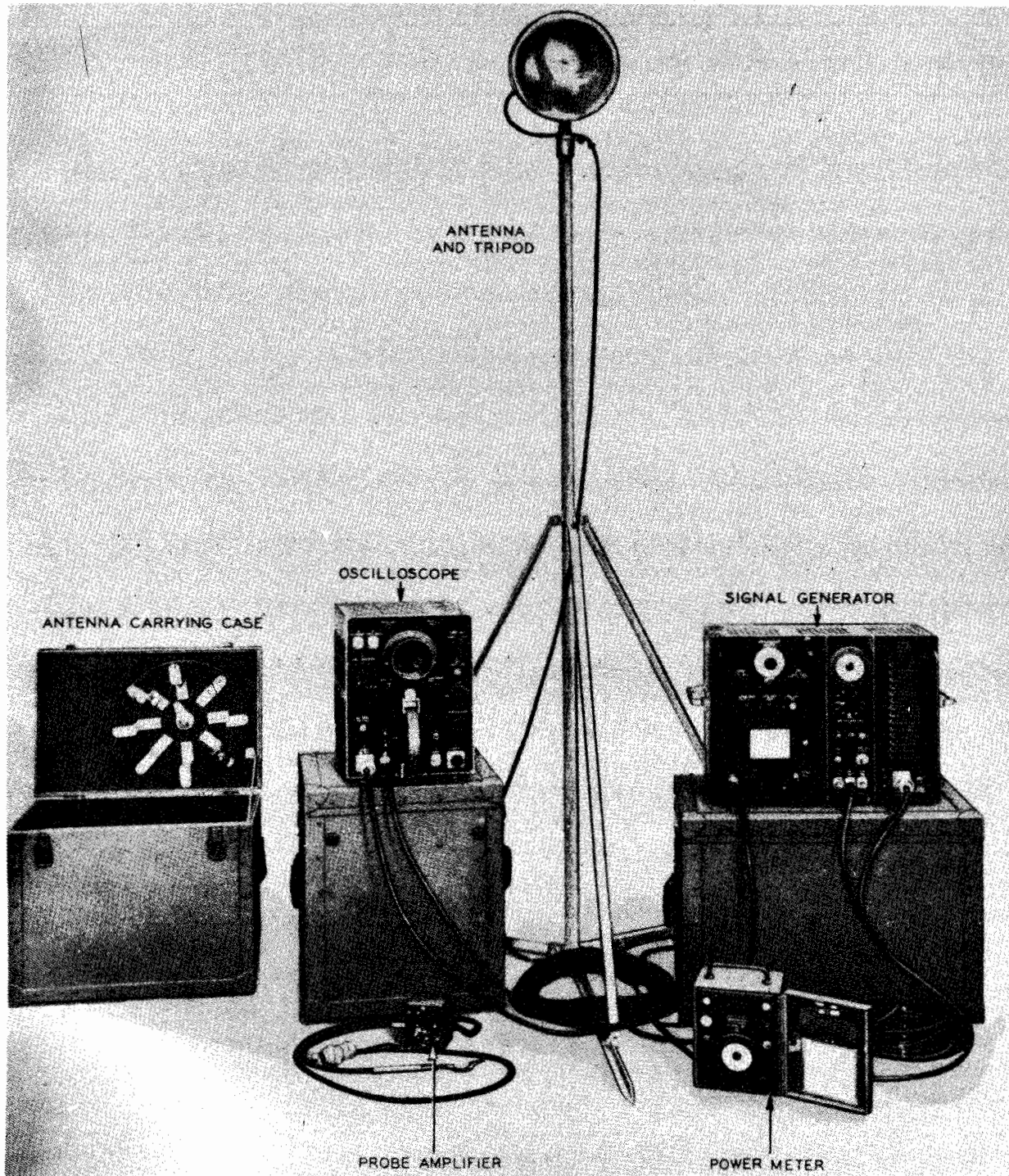

Test Equipment LZ-Showing Major Assemblies and Carrying Cases

April 1959

Test-Combination and Group

LZ**RADAR TEST EQUIPMENT****FUNCTIONAL DESCRIPTION**

The LZ is designed as a semi-portable equipment employed in maintaining radar systems operating in the range from 2700 to 3400 megacycles (mc) (11.1 to 8.8 cm).

The LZ is designed to perform the following functions:

- (1) Measuring power of a radar transmitter and beat frequency oscillator.
- (2) Measuring frequency of radar transmitter and of receiver beat frequency oscillator.
- (3) Displaying pulse shapes.
- (4) Measuring T-R Box and receiver recovery time.
- (5) Measuring space attenuation loss between radar and test antennas, and loss in cables.
- (6) Measuring receiver sensitivity.
- (7) Servicing, with LZ probe amplifier and voltage divider.
- (8) Measuring pulse duration.
- (9) Measuring IF Band width, AFC control and T-R box leakage.
- (10) Calibration of Range Mark.

No field changes in effect at time of preparation (18 May 1959).

EQUIPMENT REQUIRED BUT NOT SUPPLIED

(1) Voltage Divider TS-89/AP, (1) Tapered Adapter UG-78/AP, (1) High resistance voltmeter or milliammeter in series with high resistance, (1) Adapter NT-49291, (1) Adapter NT-49292, (1) Adapter NT-49293. (1) Adapter NT-49294.

ELECTRICAL AND MECHANICAL CHARACTERISTICS**SIGNAL GENERATOR**

WAVE METER ACCURACY: ± 1 mc.
 TYPE OF OUTPUT SIGNAL: CW or pulsed.
 POWER OUTPUT: 6 milliwatts.
 OUTPUT IMPEDANCE: 72 ohms.
 PULSE REPETITION RATE: 500 pps.
 PULSE WIDTH: 1 or usec internal; 0.5 to 50 usec, external.

OSCILLOSCOPE

CRT SIZE: 3 in.
 INPUT IMPEDANCE: 72 ohms.
 DELAY TIME: 0.5 usec.
 TYPE OF SIGNALS PRESENTED: Pulsed or sine wave.

PULSE DURATION: 0.25 to 100 usec.
 PULSE REPETITION RATE: 100 pps.
 SINE WAVE FREQUENCY: 3 kc to 1 mc.
 SWEEPS: 3 to 18 and 50 to 250 usec.

POWER METER

TYPE: Thermistor Bridge.
 RANGE: 0.5 to 12 milliwatts.
 INPUT IMPEDANCE: 72 ohms.

ANTENNA

RADIATING ELEMENT: Half-wave dipole.
 REFLECTING ELEMENT: 9 in. parabola w/w/plastic cover.
 SUPPORT: 12 ft collapsible tripod.

POWER AMPLIFIER

INPUT IMPEDANCE: 2 megs across 12 mmfd.
 PULSE MAGNITUDE: 2 to 200 ∇ peak.

POWER SOURCE REQUIRED

SIGNAL GENERATOR: 105 to 125 v, 50 to 800 cps, 250 va.
 OSCILLOSCOPE: 105 to 125 v, 50 to 1200 cps, 150 va.

MANUFACTURER'S OR CONTRACTOR'S DATA

Approximate Cost: \$1000.00 with equipment spares.

TUBE AND/OR CRYSTAL COMPLEMENT

(9) 6AC7	(1) 1622
(1) 6ZY5G	(2) SF5
(1) 0C3/VR-150	(1) 3BP1
(2) 6SN7GT	(1) 6AG7
(1) 6L7	(2) 5T4
(2) 6Y6-G	(4) 0D3/VR-150
(1) 707A	(1) 6H6
(1) 6SJ7	(1) 2X2/879

Total Tubes: (31)

No Crystals used.

REFERENCE DATA AND LITERATURE

CO-AN08-45-17: Technical Manual for Radar Test Equipment.

TYPE CLASSIFICATION
DESIGN COGNIZANCE BUAER
PROCUREMENT COGNIZANCE
STOCK NO.
R.D.B. IDENT. NO.

April 1959

Test-Combination and Group

RADAR TEST EQUIPMENT

LZ

EQUIPMENT SUPPLIED DATA

QUANTITY PER EQUIPT	NAME AND NOMENCLATURE	OVERALL DIMENSIONS (inches)	WEIGHT (lbs.)
1	Frequency Meter and Signal Generator CW-60AAX or CW-60ACA	18-1/4 X 19-13/16 X 26-1/16 11-1/8 X 14-7/8 X 18-11/16	116 72
1	Oscilloscope CW-60AAY or CW-60ACB	18 X 19-1/2 X 20-1/2 10-9/16 X 14-9/16 X 14-5/8	96 60
1	Stand CW-66ACX (uncased)	80 (collapsed)	34
1	Antenna Carrying Case Including:	15 X 17-5/8 X 21-7/8	76
1	Antenna Ass'y		5-3/4
1	Coaxial Type Antenna Cable ES-690129-2 (white band)	480 lg	
1	Double Outlet Power Cable ES-690129-1 (yellow band)	420 lg	
1	Coaxial Type Connecting Cable ES-690129-4 (Green band)	420 lg	
1	Coaxial Type Connecting Cable ES-690129-6 (Red band)	420 lg	
1	Coaxial Type Connecting Cable ES-690129-5 (Blue band)	60 lg	
1	(25 db) R.F. Connecting Cable ES-690129-3 (Orange band)	120 lg	
1	(26 db) Coaxial Type Calibrating Cable ES-690129-15		
1	Adapter-3 Conductor Power Cable ES-690129-16	120 lg	
1	Power Meter CW-60AB0	6-3/8 X 7-1/16 X 9-3/4	7-1/2
1	Probe Amplifier CW-50ADB		2-3/4

April 1958

MULTIMETER

Test-Combination and Group

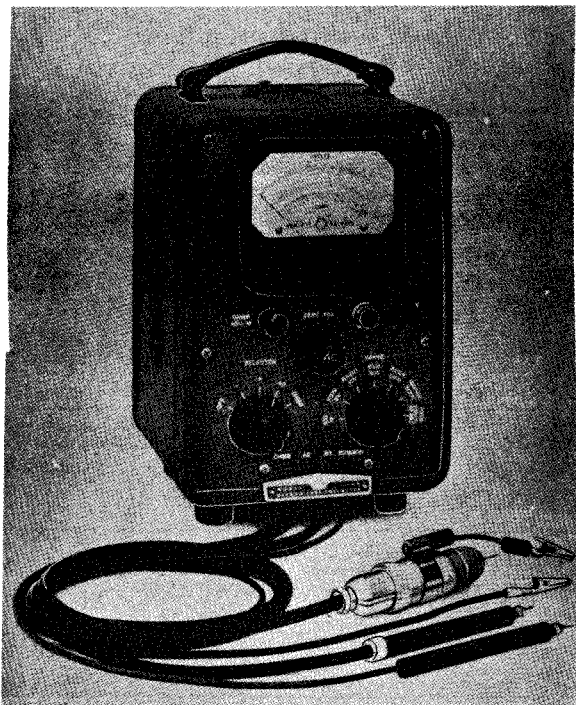
ME-26/U, ME-26A/U

Multimeter ME-26/U, ME-26A/U

FUNCTIONAL DESCRIPTION

The ME-26/U (Hewlett-Packard Model 410A) and ME-26A/U (Hewlett-Packard Model 410B) are a self contained laboratory quality instrument designed for making voltage and resistance measurements. With this equipment it is possible to accurately measure AC voltages from 1 to 300 v in the frequency range from 20 cps to over 700 mc, and to obtain useful indications as high as 1500 mc. This meter also measures DC voltages from 1 volt to 1000 volts and resistance values from 1 ohm to 500 megohms.

No field changes in effect at time of preparation (19 March 1958).

RELATION TO OTHER EQUIPMENT

The ME-26/U is similar to Hewlett-Packard Model 410A and ME-26A/U is similar to Hewlett-Packard Model 410B.

ELECTRICAL AND MECHANICAL CHARACTERISTICS

FREQUENCY RANGE: 20 cycle to 700 mc (on AC voltage measurement).

FREQUENCY RESPONSE: Flat within ± 1 db from 20 cycle to 700 mc; at 20 cycle drop off is less than 1 db.

PROBE RESONANT FREQUENCY

ME-26/U: 2,000 mc (approx); however, indication to 3,000 mc are obtainable.

ME-26A/U: 1,500 mc (approx); however, indication to 3,000 mc are obtainable.

INPUT IMPEDANCE**INPUT CAPACITANCE**

ME-26/U: 1.3 uuf across the input resistance.

ME-26A/U: 1.5 uuf across the input resistance.

INPUT RESISTANCE: 10 meg at low frequency (below 0.02 mc).

RESISTANCE RANGE: 0.2 to 500 meg in seven ranges.

VOLTAGE RANGE: 0 to 300 v rms AC in six ranges; 0 to 1,000 v DC in seven ranges $\pm 3\%$.

POWER REQUIREMENTS

ME-26/U: 115 v, 50 to 60 cps, single ph, 40 W; 3 v DC.

ME-26A/U: 115 v or 230 v, 50 to 60 cps, single ph, 40 W.

MANUFACTURER'S OR CONTRACTOR'S DATA

Hewlett-Packard Co, Palo Alto, Calif.

Contract: (ME-26/U) NObsr-40943.

Contract: (ME-26A/U) NObsr-63463, dated 4 June 1954.

Contract: NObsr-64746.

TUBE AND/OR CRYSTAL COMPLEMENT

	ME-26/U	
(1) 5Y3GT		(1) 6SN7GT
(2) 6AG7		
Total Tubes:	(4)	
	ME-26A/U	
(1) OB2		(1) 2-PIC
(1) 6X4		(2) 12AU7
Total Tubes:	(5)	
	ME-26/U	
(1) 1N34		
Total Crystals:	(1)	

Test-Combination and Group
ME-26/U, ME-26A/U

MULTIMETER

April 1958

ME-26A/U

No Crystals used.

Manual for Model 410B High Frequency Vacuum Tube Voltmeter.

REFERENCE DATA AND LITERATURE

TM11-487H-1: Electron Test Equipment
 NAVSHIPS 92242: Technical Manual for Multimeter ME-26A/U.
 NAVSHIPS 92648: Instruction and Operating

TYPE CLASSIFICATION
 DESIGN COGNIZANCE
 PROCUREMENT COGNIZANCE
 STOCK NO.
 R.D.B. IDENT. NO.

SHIPPING DATA

NUMBER OF BOXES	CONTENTS AND IDENTIFICATION	VOLUME (Cu.Ft.)	OVERALL DIMENSIONS (inches)	WEIGHT PACKED (lbs.)
1	Multimeter ME-26/U	0.58	8-1/4 x 8-5/16 x 14-5/8	23
1	Multimeter ME-26A/U			

EQUIPMENT SUPPLIED DATA

QUANTITY PER EQUIPT	NAME AND NOMENCLATURE	OVERALL DIMENSIONS (inches)	WEIGHT (lbs.)
1	ME-26/U Multimeter ME-26/U including:	6-1/4 x 7-5/16 x 12-1/16	16
1	Set of Test Leads		
1	ME-26A/U Multimeter ME-26A/U including:	7-1/4 x 11-1/2 x 12-1/4	
1	Set of Test Leads		

MAINTENANCE EQUIPMENT

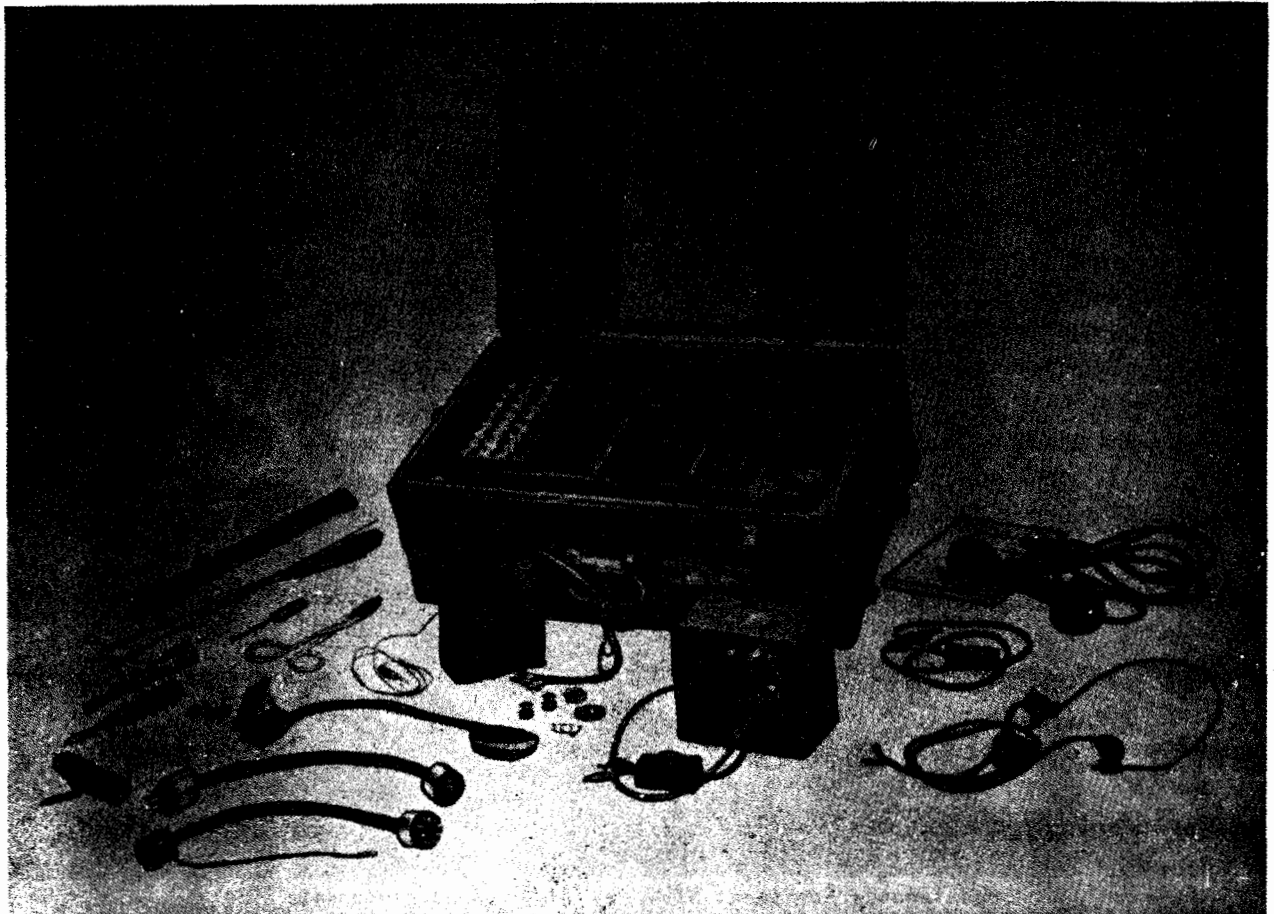

Maintenance Equipment ME-40-F, upper chest components

FUNCTIONAL DESCRIPTION

The ME-40-A,-B,-C,-D,-E, and -F are used for aligning, adjusting, troubleshooting and repairing Radio Receiver and Transmitter BC-1000-(*).

The equipment consists of Alignment Indicator I-210-(*), which can be used for resistance (0 to 50,000 ohms) and voltage (0 to 30 volts) measurements; Oscillator VO-6-(*), which generates an aligning signal of 4-3 megacycles; artificial antenna, Antenna A-28 (phantom) and additional components.

No field changes in effect at time of preparation (29 March 1957).

ELECTRICAL AND MECHANICAL CHARACTERISTICS

ALIGNMENT INDICATOR

VOLTAGE RANGES: 0 to 4.5, 0 to 6, 0 to 30 v.

RESISTANCE RANGE: 0 to 50,000 ohms.

POWER SOURCE REQUIRED: 7.5 and 150 v DC or 4.5 v, 90 and 60 v DC.

VACUUM-TUBE INDICATOR: 6E5.

OSCILLATOR

CRYSTAL FREQUENCY OUTPUT: 4.3 mc.

OUTPUT VOLTAGE

ME-40,-A,-B,-E: 5 to 250,000 uv.

ME-40-C,-D: 5 to 140,000 uv.

POWER SOURCE REQUIRED: 1.5 and 67.5 v.

TUBE AND/OR CRYSTAL COMPLEMENT

(5) 1A3

(5) 1R5

(24) 1L4

(15) 1S5

Total Tubes: (90)

(30) 1T4

(10) 3A4

(1) 6E5

Test-Combination and Group

ME-40-A,-B,-C,-D,-E,-F MAINTENANCE EQUIPMENT

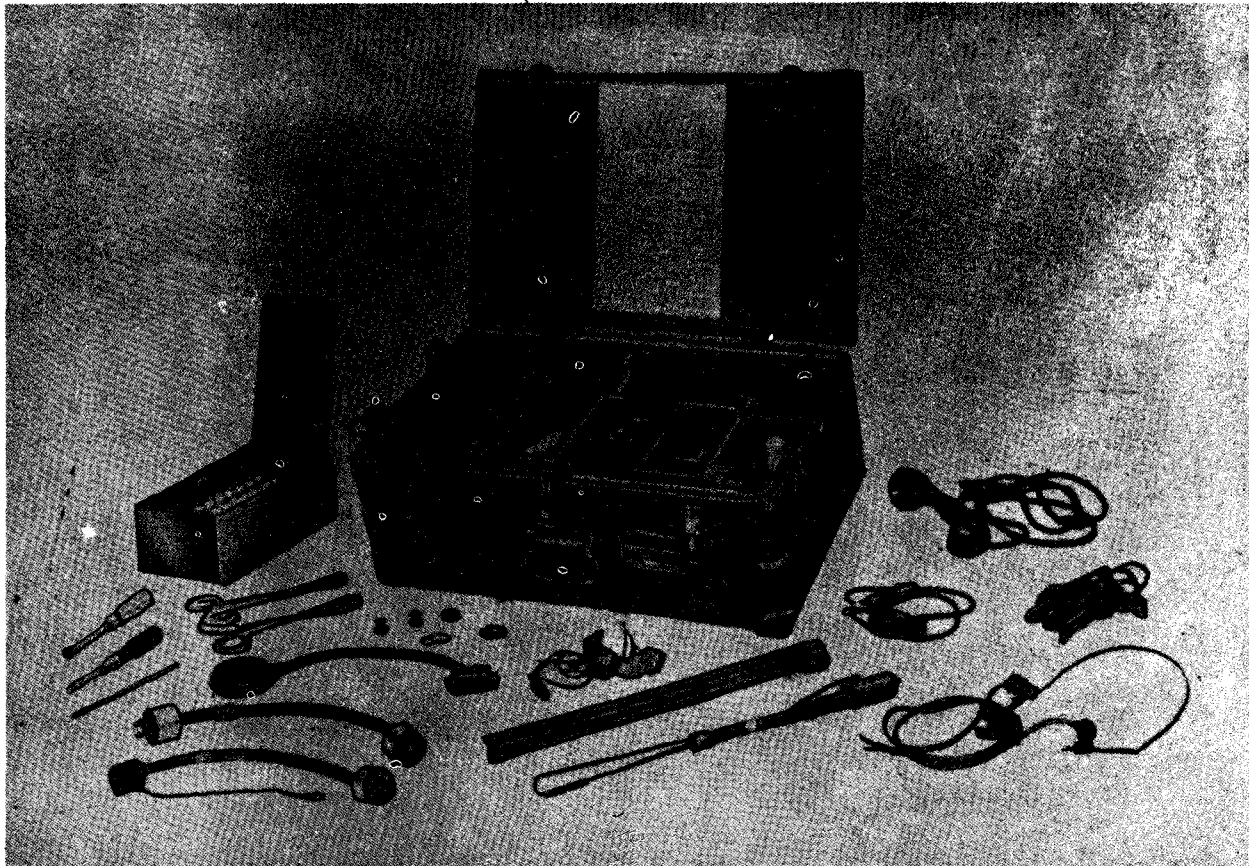

Maintenance Equipment ME-40-P, lower chest components

REFERENCE DATA AND LITERATURE

Technical Manual TM11-315 for Maintenance
Equipment ME-40-A,-B,-C,-D,-E,-F.

TYPE CLASSIFICATION DESIGN COGNIZANCE TASSA PROCUREMENT COGNIZANCE STOCK NO. R.D.B. IDENT. NO.

SHIPPING DATA

NUMBER OF BOXES	CONTENTS AND IDENTIFICATION	VOLUME (Cu.Ft.)	OVERALL DIMENSIONS (inches)	WEIGHT PACKED (lbs.)
1	(2) Chests CH-165-A,-B,-C,-D,-E,-F	18.5	23-1/2 X 28 X 48-1/2	214

UNCLASSIFIED

October 1957

Test-Combination and Group

MAINTENANCE EQUIPMENT

ME-40-A,-B,-C,-D,-E,-F

EQUIPMENT SUPPLIED DATA

QUANTITY PER EQUIPT	NAME AND NOMENCLATURE	OVERALL DIMENSIONS (inches)	WEIGHT (lbs.)
1	Alignment Indicator I-210-A,-B,-C,-D,-E,-F	2-1/16 X 4-11/32 X 5-5/16	1.5
2	Antenna A-28 (phantom)	4 X 1-1/16	0.2
6	Antenna AN-130-A,-B,-C,-D,-E,-F	33	0.6
6	Antenna AN-131-A	128 X 21/32	0.93
2	Chest, CH-165-A,-B,-C,-D,-E,-F	13-1/2 X 17-1/2 X 22-1/2	55
3	Cord CD-874	39	0.25
2	Cord CD-1016	12	0.25
2	Cord CD-1108	15	0.3
3	Handset H-23/U	78 w/cord	1.5
3	Headset HS-30	6 X 30 w/cord	0.4
1	Oscillator VO-6-A,-B,-C,-D,-E,-F	3-11/16 X 5-3/16 X 5-3/8	3.8
2	Screwdriver TL-15		0.2
3	Alignment Tool		0.1
3	Tube Puller TL-201	4-1/2 X 8	0.2
3	Wrench TL-108	6	0.2
1	Microphone		0.2

UNCLASSIFIED

4.10 ME-40-A: 3

FREQUENCY-POWER METER

ME-51/UP

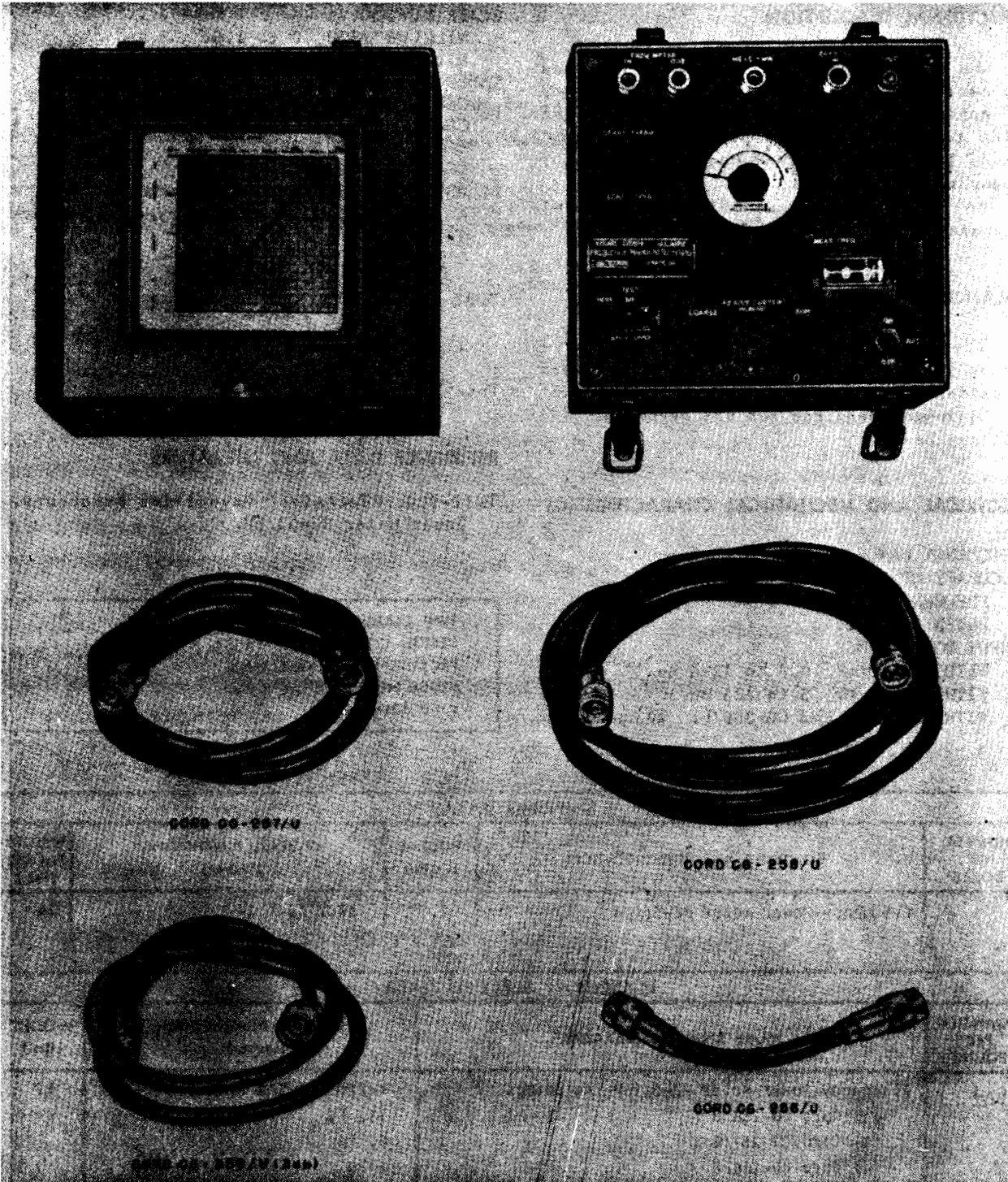

Frequency-Power Meter ME-51/UP

Test-Combination and Group

ME-51/UP

FREQUENCY-POWER METER

FUNCTIONAL DESCRIPTION

The ME-51/UP is a portable meter designed to measure the average power and frequency of continuous wave or pulsed signals in the 3100 to 3500 megacycle portion of the "S" band. It is used to test the performance of radar transmitters.

No field changes in effect at time of preparation (11 February 1957).

RELATION TO OTHER EQUIPMENT

The ME-51/UP is similar to Frequency-Power Meter TS-295/UP except that it covers a different frequency range.

Equipment Required but not Supplied: (3)
Battery BA-30.

ELECTRICAL AND MECHANICAL CHARACTERISTICS

FREQUENCY RANGE: 3100 to 3500 mc

ACCURACY OF MEASUREMENT

FREQUENCY: ±2 mc.

POWER: ±1 db.

INPUT POWER RANGE

WITHOUT CORDS: 0.5 to 12.5 mw.

WITH CG-258/U: 5 to 125 mw.

WITH CG-258/U and CG-358/U: 10 to 250 mw.

SCALE RANGES

MILLIAMPERES: 0 to 1.5.

MILLIWATTS: 0 to 22.5.

CABLE INSERTION LOSS

CG-258/U: 10 db.

CG-257/U: 1.25 db.

CG-256/U: 0.5 db.

CG-358/U: 3 db.

RF CONNECTORS IMPEDANCE: 50 ohms.

POWER REQUIREMENTS: 4.5 v DC dry-cell batteries.

TUBE AND/OR CRYSTAL COMPLEMENT

(1) 1N21B

Total Crystals: (1)

REFERENCE DATA AND LITERATURE

TM11-320: Technical Manual for Frequency-Power Meter ME-51/UP.

TYPE CLASSIFICATION
DESIGN COGNIZANCE TASSA
PROCUREMENT COGNIZANCE
STOCK NO.
R.D.B. IDENT. NO.

SHIPPING DATA

NUMBER OF BOXES	CONTENTS AND IDENTIFICATION	VOLUME (Cu.Ft.)	OVERALL DIMENSIONS (inches)	WEIGHT PACKED (lbs.)
1	Frequency-Power Meter ME-51/UP	1.1	12 X 12 X 14	16

EQUIPMENT SUPPLIED DATA

QUANTITY PER EQUIPT	NAME AND NOMENCLATURE	OVERALL DIMENSIONS (inches)	WEIGHT (lbs.)
1	Frequency-Power Meter ME-51/UP including: (1) Cord CG-258/U (1) Cord CG-257/U (1) Cord CG-256/U (1) Cord CG-358/U (2) Technical Manual TM11-320 (1) Wrench, Allen No. 8 (1) Set of Spares	9-1/8 X 9-1/2 X 11-3/8 132 1g 60 1g 6 1g 41 1g 1/8 X 7-7/8 X 10-1/4 1-7/8 1g	12

4.10 ME-51/UP: 2

June 1957

Test-Combination and Group

TEST SET GROUP

0A-1104/MPS-4

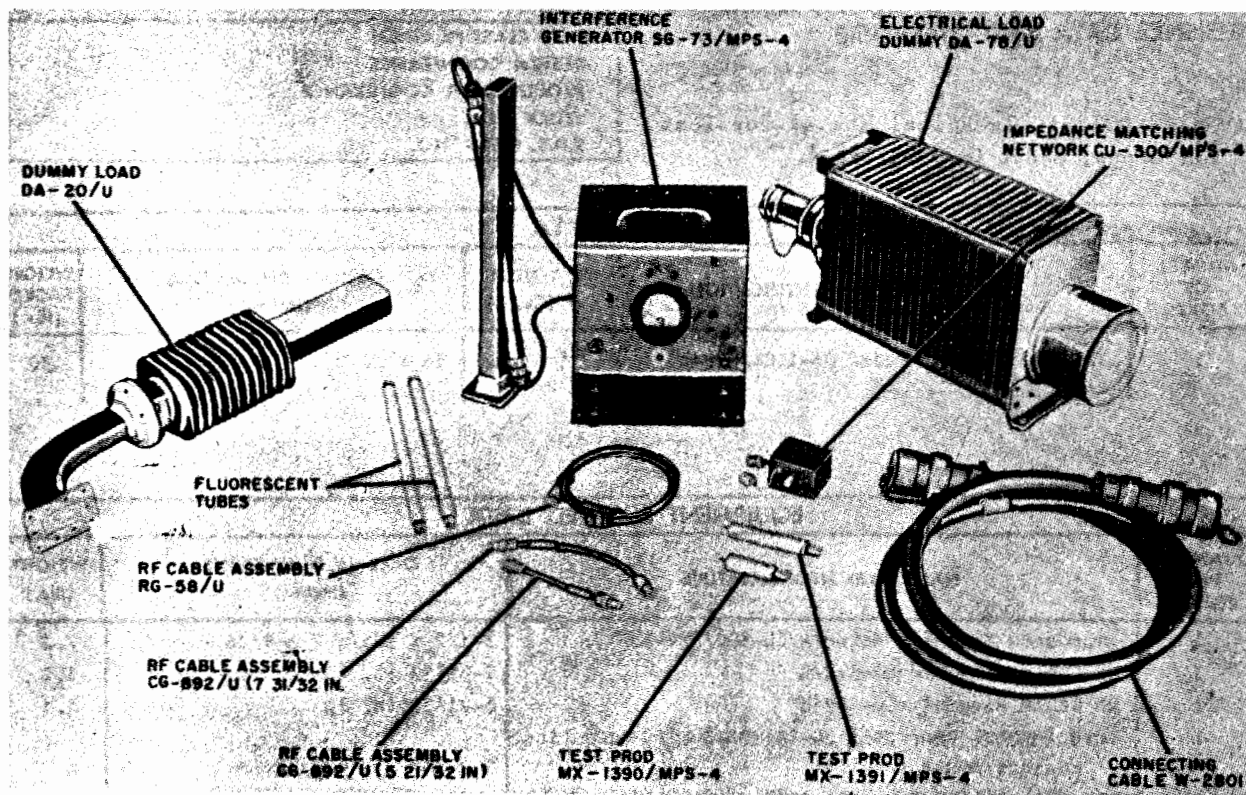

Test Set Group 0A-1104/MPS-4

FUNCTIONAL DESCRIPTION

The 0A-1104/MPS-4 is designed for use in corrective maintenance of Radar Set AN/MPS-4C. It is used to align the IF amplifiers of Radar Receiver-Transmitter RT-140/MPS-4 and for making checks on the over-all performance of the radar set. The various components of the equipment will simulate the output impedance of the crystal mixers of the Radar Receiver-Transmitter, generate a noise signal for determining the receiver noise figure, provide a test load for the radar modulator, provide a means of coupling test signals into and IF stage and for sampling IF signals for presentation on an oscilloscope.

No field changes in effect at time of preparation (11 October 1956).

ELECTRICAL AND MECHANICAL CHARACTERISTICS

IMPEDANCE MATCHING NETWORK
INPUT IMPEDANCE: 50 ohms.

UNCLASSIFIED

OUTPUT IMPEDANCE: 300 ohms.
INTERFERENCE GENERATOR
FREQUENCY: Between 6200 and 6600 mc.
IMPEDANCE: 500 ohms.
STANDING WAVE RATIO: 0.2 db average, 0.6 db max.
RANDOM NOISE OUTPUT: 58.84 db.
ELECTRICAL LOAD DUMMY DA78/U.
IMPEDANCE: 50 ohms.
FREQUENCY: DC to 4000 mc.
DUMMY LOAD DA-20/U.
VOLTAGE STANDING WAVE RATIO: 1.5

MANUFACTURER'S OR CONTRACTOR'S DATA

Hazeltine Electronics Corporation, Little Neck, New York
Contract NObsr 64200, dated 23 June 1954.

TUBE AND/OR CRYSTAL COMPLEMENT

No Electron Tubes.

June 1957

Test-Combination and Group

OA-1104/MPS-4

TEST SET GROUP

REFERENCE DATA AND LITERATURE

NAVSHIPS 92635: Technical Manual for Test
Set Group, Radar OA-1104/MPS-4.

TYPE CLASSIFICATION	BUSHIPS
DESIGN COGNIZANCE	
PROCUREMENT COGNIZANCE	
STOCK NO.	
R.D.B. IDENT. NO.	

SHIPPING DATA

NUMBER OF BOXES	CONTENTS AND IDENTIFICATION	VOLUME (Cu.Ft.)	OVERALL DIMENSIONS (inches)	WEIGHT PACKED (lbs.)
1	Test Set Group, Radar OA-1104/MPS-4	(cu in.) 13,440	16 X 20 X 42	130

EQUIPMENT SUPPLIED DATA

QUANTITY PER EQUIPT	NAME AND NOMENCLATURE	OVERALL DIMENSIONS (inches)	WEIGHT (lbs.)
1	Impedance Matching Network CU-300/MPS-4	2-1/2 X 1-5/8 X 3-9/16	7.2
1	RF Cable Assembly CG-892/U	7-31/32 in. lg	1.2
1	RF Cable Assembly CG-892/U	5-21/32 in. lg	1.1
1	Interference Generator SG-73/MPS-4 and lamp ballast MX-1423/MPS-4	8 X 8-3/4 X 9-3/16	6
1	Electrical Load Dummy DA-20/U	3-3/16 X 6 X 21-1/16	6
1	Electrical Load Dummy DA-78/U	5-1/8 X 8-1/2 X 21-15/16	18
	Test Prods and Connecting Cables		

POWER SUPPLY GROUP

OA-565A/MPM-24

No field changes in effect at time of preparation (7 May 1957).

RELATION TO OTHER EQUIPMENT

Similar to OA-565/MPM-24 except for use of individual waterproof transit cases.

ELECTRICAL AND MECHANICAL CHARACTERISTICS

POWER SOURCE: 115 v, 60 cps, single ph.
 POWER INPUT: 175 W.
 VOLTAGE OUTPUTS: +300 v DC, -300 v DC, +250 v DC, +200 v DC, +150 v dc, 6.3 v AC.
 SIGNAL OUTPUTS: Slant range error signal, elevation angle signal upper, elevation angle signal lower, 0 to 150 v DC signal.

MANUFACTURER'S OR CONTRACTOR'S DATA

Sperry Gyroscope Co., Great Neck, N.Y.
 Contract 33698-PHILA-55.

TUBE AND/OR CRYSTAL COMPLEMENT

(5) 5R4WGA (8) 6AS7G (5) 5751 (8) OB2

Total Tubes: (26)

REFERENCE DATA AND LITERATURE

TB11-1503-1, Technical Manual for Power Supply Group OA-565A/MPM-24.

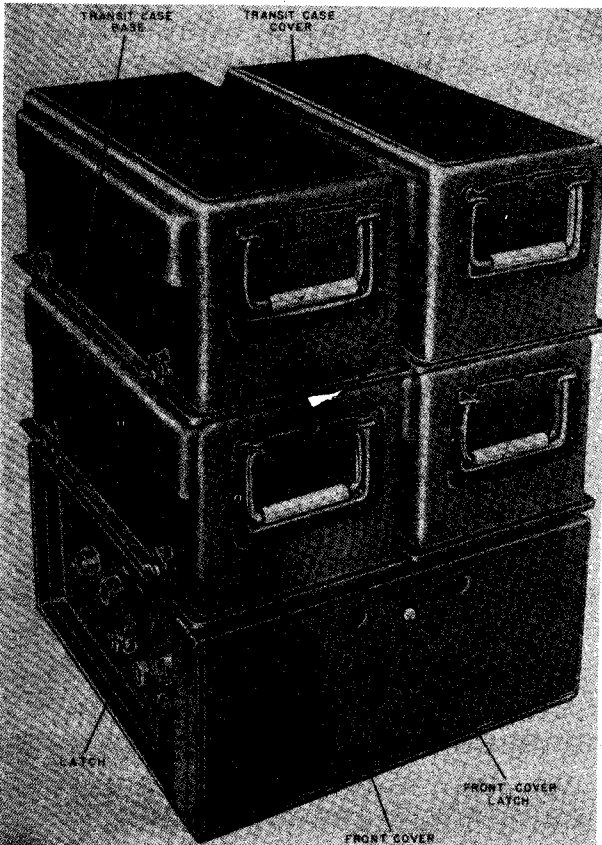

Power Supply Group OA-565A/MPM-24

FUNCTIONAL DESCRIPTION

The OA-565A/MPM-24 is a compact test equipment designed to provide power, simulated signals and resistive loads for certain removeable components of Radar Sets AN/MPQ-10 and AN/MPQ-10A. The power supply group aids in trouble shooting and aligning the radar set components.

TYPE CLASSIFICATION
DESIGN COGNIZANCE TASSA
PROCUREMENT COGNIZANCE
STOCK NO.
R.D.B. IDENT. NO.

SHIPPING DATA

NUMBER OF BOXES	CONTENTS AND IDENTIFICATION	VOLUME (Cu.Ft.)	OVERALL DIMENSIONS (inches)	WEIGHT PACKED (lbs.)
1	Power Supply Group OA-565A/MPM-24	11.5	21 X 21 X 45	313

Test-Combination and Group

January 1958

OA-565A/MPM-24

POWER SUPPLY GROUP

EQUIPMENT SUPPLIED DATA

QUANTITY PER EQUIPT	NAME AND NOMENCLATURE	OVERALL DIMENSIONS (inches)	WEIGHT (lbs.)
1	Control-Power Supply C-1774/MPM-24	10-1/4 X 19-1/2 X 20	62
2	Power Supply PP-745/MPQ-10	6-1/2 X 8 X 18-1/4	33
1	Power Supply PP-746/MPQ-10	6-1/2 X 8 X 18-1/4	23
1	Voltage Regulator CN-167/MPQ-10	8 X 8-5/8 X 18-3/4	21
4	Electrical Standardized Components Case CY-2076/G	9-3/32 X 10-1/4 X 20-1/2	13
1	Electrical Power Cable Assembly CX-2901/U	72 lg	1
2	Electrical Power Cable Assembly CX-3975/U	72 lg	2
1	Electrical Power Cable Assembly CX-3976/U	72 lg	2
1	Electrical Power Cable Assembly CX-3977/U	72 lg	2
5	Electrical Power Cable Assembly CX-3978/U	72 lg	
2	Electrical Power Cable Assembly CX-3979/U	72 lg	2
2	Technical Manuals TB-11-1503-1		

June 1957

Test-Combination and Group

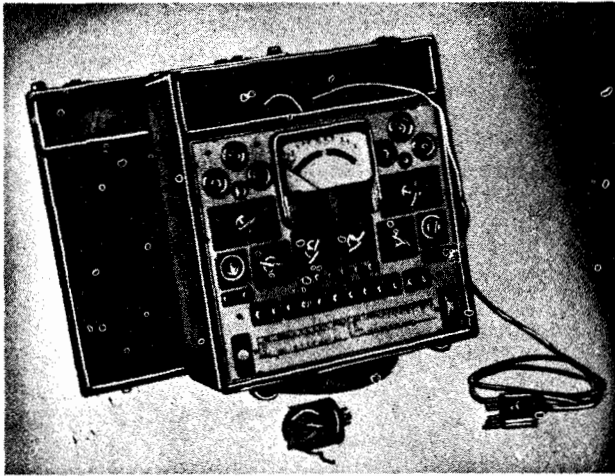
PORTABLE VACUUM TUBE TESTER**OAL(60057,I-157-A)**

Portable Vacuum Tube Tester OAL(60057, I-157-A)

FUNCTIONAL DESCRIPTION

The OAL (60057, I-157-A) is a combination tube tester and multipurpose meter. It is used to check radio tubes, portable radio batteries, pilot lights, and mica, paper and electrolytic capacitors. It is also used to obtain rapid measurements of voltage, current, resistance output readings, decibel readings, and DC leakage.

No field changes in effect at time of preparation (14 September 1956).

ELECTRICAL AND MECHANICAL CHARACTERISTICS

SENSITIVITY: 1000 ohms per volt for AC and DC.

VOLTAGE RANGE: 0 to 12,60,300,600,1200 and 3000 v.

CURRENT RANGE: 0 to 1.2, 12, 120, and 600 ma; 0 to 12 amp.

RESISTANCE MEASUREMENT: 0 to 400 and 100,000 ohms; 0 to 1 and 10 meg

DB MEASUREMENT: -10 to ± 64 db.

OUTPUT VOLTAGE MEASUREMENT: 0 to 12,60,300, 600, 1200 and 3000 v.

OPERATING POWER: 115 to 125 v, 50 to 60 cps.

MANUFACTURER'S OR CONTRACTOR'S DATA

Precision Apparatus Co. Elmhurst, Long Island, N.Y.

Contract NXss 17723.

Approximate Cost: \$260.00 with equipment spares.

TUBE AND/OR CRYSTAL COMPLEMENT

(1) 80

Total Tubes: (1)

REFERENCE DATA AND LITERATURE

Technical Manual for Portable Vacuum Tube Tester CPF-60057.

TM11-487H Technical Manual for Test Equipment.

TYPE CLASSIFICATION
DESIGN COGNIZANCE BUSHIPS
PROCUREMENT COGNIZANCE
STOCK NO.
R.D.B. IDENT. NO.

SHIPPING DATA

NUMBER OF BOXES	CONTENTS AND IDENTIFICATION	VOLUME (Cu.Ft.)	OVERALL DIMENSIONS (inches)	WEIGHT PACKED (lbs.)
1	Tube Tester OAL (60057,I-157-A)	1.25		36.9

EQUIPMENT SUPPLIED DATA

QUANTITY PER EQUIP	NAME AND NOMENCLATURE	OVERALL DIMENSIONS (inches)	WEIGHT (lbs.)
1	Tube Tester OAL(60057, I-157-A)	6 x 12-11/16 x 13-11/16	15
1	Lamp, Neon G10		
1	Acorn Tube Adapter		
1	Test Lead, Pair		

UNCLASSIFIED

April 1958

Test-Combination and Group

WAVEMETER-OSCILLATOR

OAP, OAP-1, -1a

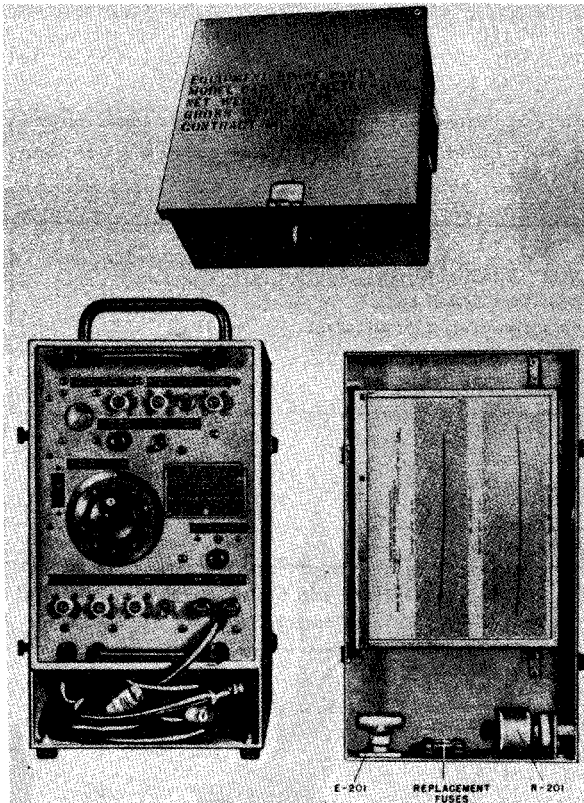

Wavemeter-Oscillator OAP, OAP-1, -1a

FUNCTIONAL DESCRIPTION

The OAP, OAP-1 and -1a are test and monitoring instruments designed for measuring the frequency of pulse-modulated transmitters and receivers, and for testing and adjusting such equipments. The OAP, and OAP-1 are suitable for use with a wide range of Navy apparatus operating in the frequency band of 150 to 230 mc while the model OAP-1a operates over an extended range of 150 to 275 mc. Measurements can be made on transmitters whose radiated power during a pulse lies in the range from 3 kilowatts to less than 100 watts.

These equipments can be used to tune a receiver to a given frequency, adjust an antenna system for best performance, tune a transmitter to a given frequency, measure the power output of a transmitter or obtain the pulse shape and monitor a transmitter during operation.

The equipments differ from each other in that the OAP-1 and 1a can be operated from a

400 cps power source as well as a 60 cps source and in that the OAP-1a has an extended frequency range.

No field changes in effect at time of preparation (9 April 1958).

RELATION TO OTHER EQUIPMENT

These equipments are designed for use with MK 3 IFF Equipment.

ELECTRICAL AND MECHANICAL CHARACTERISTICS

WAVEMETER DATA

FREQUENCY RANGE

OAP, OAP-1: 150 to 230 mc.

OAP-1a: 150 to 275 mc.

ACCURACY: $\pm 0.25\%$ from 0 to 50 deg C.

INPUT IMPEDANCE: 50 ohms.

SIGNAL POWER INPUT: 0.5 W max.

OSCILLATOR DATA

FREQUENCY RANGE

OAP, OAP-1: 150 to 230 mc.

OAP-1a: 150 to 275 mc.

ACCURACY: $\pm 0.25\%$ from 0 to 50 deg C.

MODULATION: Line frequency.

OUTPUT: Approx 10 mv.

IMPEDANCE: 50 ohms.

POWER METER DATA

FREQUENCY RANGE: VTVM input (untuned).

INPUT IMPEDANCE: 50 ohms.

RELATIVE LEVEL INDICATION: Tuning indicator.

INPUT POWER: 0.5 W max.

CALIBRATING VOLTAGE: 18 v peak-to-peak.

DUMMY ANTENNA DATA

IMPEDANCE: 50 ohms.

RATED POWER: 8 W continuous duty.

POWER SOURCE REQUIRED

OAP: 110 to 120 v AC, 50 to 70 cps 30 W.

OAP-1, -1a: 110 to 120 v AC, 50 to 70 cps or 400 cps.

MANUFACTURER'S OR CONTRACTOR'S DATA

Hazeltine Electronics Corp, New York, N.Y.

Contract NXss-22208, dated 17 June 1943 (OAP).

Contract NXsr-46027, dated 12 June 1944 (OAP-1 and OAP-1a).

Contract NXsr-38852 dated 13 October 1943 (OAP-1 and OAP-1a).

Contract NOrd-4621 dated 22 October 1943 (OAP-1 and OAP-1a).

TUBE AND/OR CRYSTAL COMPLEMENT

OAP

(1) 6E5
(1) 6J6WA

(1) 704A
(1) 9006

UNCLASSIFIED

4.10 OAP: 1

April 1958

Test-Combination and Group

OAP, OAP-1,-1a**WAVEMETER-OSCILLATOR**

(2) 6SN7WGTA (1) 6X5WGT

Total Tubes: (7)

OAP-1, -1a

(1) 6C4WA (1) 704A

(1) 6E5 (1) 9006

(2) 6SN7WGTA (1) 6X5WGT

Total Tubes: (7)

No Crystals Used.

OAP Wavemeter-Oscillator.
 NAVSHIPS 900001: Technical Manual for Model
 OAP-1 Wavemeter-Oscillator.
 Project Order 21700/54: Recalibration of Navy
 Model OAP-1 to extend frequency coverage.

TYPE CLASSIFICATION
 DESIGN COGNIZANCE BUSHIPS
 PROCUREMENT COGNIZANCE
 STOCK NO.
 R.D.B. IDENT. NO.

REFERENCE DATA AND LITERATURE

NAVSHIPS 95163: Technical Manual for Model

EQUIPMENT SUPPLIED DATA

QUANTITY PER EQUIPT	NAME AND NOMENCLATURE	OVERALL DIMENSIONS (inches)	WEIGHT (lbs.)
1	Wavemeter-Oscillator -60ABN* or -60ACQ** or -60ACQ-1***	8-1/2 X 10-1/2 X 15-1/8 8-1/2 X 10-1/2 X 15-1/8 8-1/2 X 10-1/2 X 15-1/8	
1	Receiver Cable	60 lg	
1	Transmitter Cable	84 lg	
1	Scope Cable	60 lg	
1	T Connector		
1	Separate Receiver Gain Control		
1	Technical Manual NAVSHIPS 95163* or NAVSHIPS 900001** or NAVSHIPS 900001-18***		
1	Set of Maintenance Repair Parts		

NOTES: *Supplied w/OAP only
 **Supplied w/OAP-1 only
 ***Supplied w/OAP-1a only

April 1958

PORTABLE UNDERWATER SOUND TESTING EQUIPMENT

OAX, OAX-1

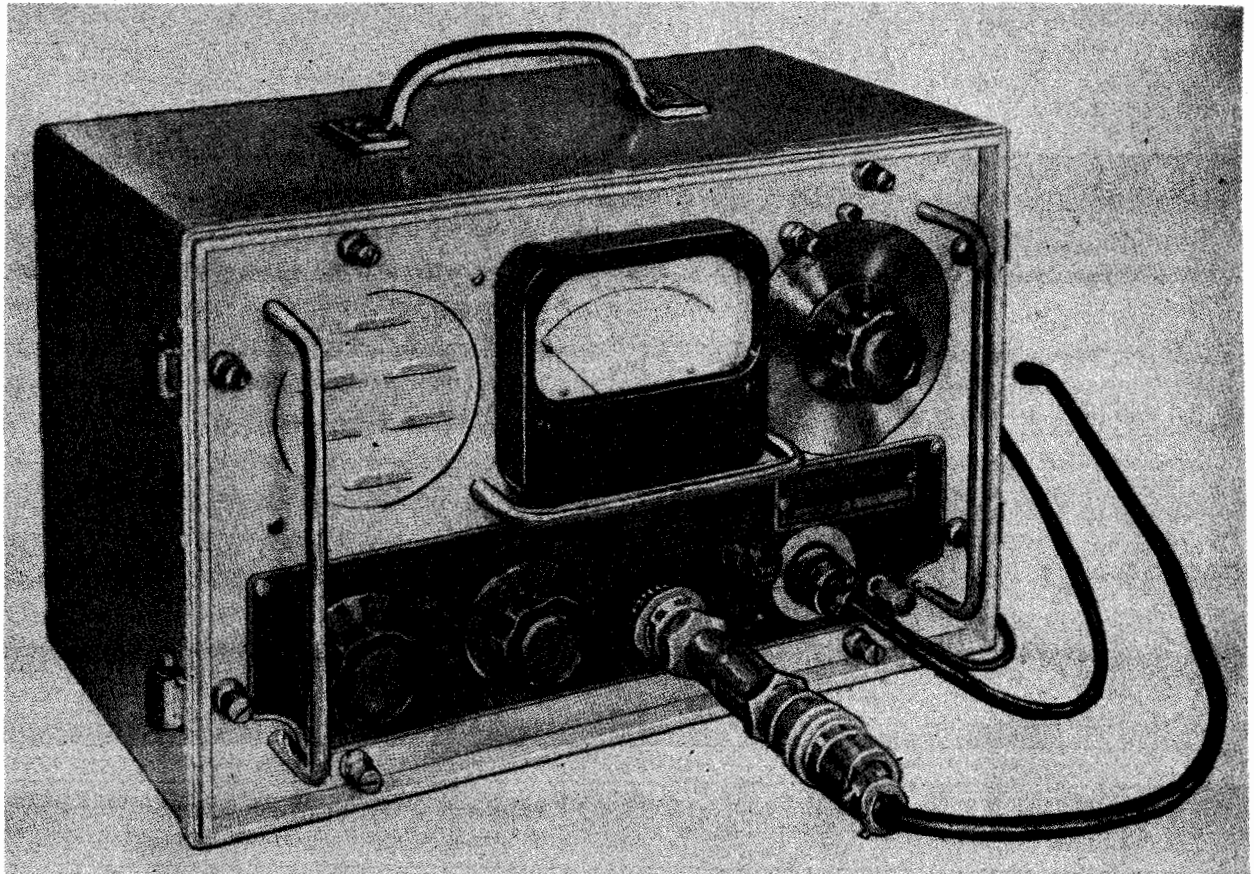

Portable Underwater Sound Testing Equipment OAX

FUNCTIONAL DESCRIPTION

The Models OAX and OAX-1 are portable equipments designed for measuring the performance of shipboard underwater sound echo ranging and listening equipment. They are essentially a combination oscillator-amplifier and hydrophone transducer for transmitting and receiving underwater sound signals under known conditions for test purposes.

The Models OAX and OAX-1 are similar in function and performance, differing mainly in size and weight.

No field changes in effect at time of preparation (28 October 1957).

RELATION TO OTHER EQUIPMENT

The Navy Models OAX and OAX-1 are superseded by Navy Model OCP Series Sonar Portable Testing Equipments.

ELECTRICAL AND MECHANICAL CHARACTERISTICS

FREQUENCY RANGE: 17 to 26 kc.

POWER OUTPUT

OSCILLATOR (SIGNAL FREQUENCY): 0.35 W standard, 0.035 W at -10 db, 22% max rms distortion.

AMPLIFIER (AUDIO FREQUENCY): 1 W, 15% max rms distortion.

HYDROPHONE (SIGNAL FREQUENCY): 1 W.

IMPEDANCE DATA

OSCILLATOR OUTPUT: 100 ohms.

AMPLIFIER

SIGNAL FREQUENCY: 100 ohms, input and output.

AUDIO FREQUENCY: 4 ohms, output.

HYDROPHONE: Approx 100 ohms (R30 + j50 ohms at 20 kc).

SENSITIVITY

AMPLIFIER: 0 db with input of 40 to 51 uv, variable attenuator provides 3 db steps over 60 to 117 db and infinity.

HYDROPHONE: -111 to -122 db vs 1 v per bar.

Test-Combination and Group

OAX,OAX-1**PORTABLE UNDERWATER SOUND
TESTING EQUIPMENT**

April 1958

CALIBRATIONOSCILLATOR TUNING DIAL: Within ± 200 cps.ATTENUATOR ACCURACY: Within ± 0.5 db on any step or receive condition.

POWER REQUIREMENTS: 115 v, 60 cps, single ph, 50 W.

HYDROPHONE DATA

FREQUENCY RANGE: 17 to 26 kc, uniform within 6 db throughout range, less than 3 db per kc variation in response.

TYPE: Magnetostrictive.

TUBE AND/OR CRYSTAL COMPLEMENT

(1) OD3W (1) 6SN7WGTA

(1) 5Y3WGTB (1) 6V6GTY

(3) 6SJ7

Total Tubes: (7)

REFERENCE DATA AND LITERATURE

NAVSHIPS 900419: Technical Manual for Portable Underwater Sound Testing Equipment Model OAX.

NAVSHIPS 900308: Technical Manual for Navy Model OAX-1 Portable Underwater Sound Testing Equipment.

MANUFACTURER'S OR CONTRACTOR'S DATA

Harvey Radio Laboratories, Inc., Cambridge, Mass.

Contract NXsr-33629, dated 30 June 1943 (OAX).

Presto Recording Corporation, New York, N. Y.

Contract NXss-33630, dated 30 June 1943 (OAX-1).

Contract NXsr-56823, dated 26 April 1944 (OAX-1).

TYPE CLASSIFICATION
DESIGN COGNIZANCE BUSHIPS
PROCUREMENT COGNIZANCE
STOCK NO.
R.D.B. IDENT. NO.

SHIPPING DATA

NUMBER OF BOXES	CONTENTS AND IDENTIFICATION	VOLUME (Cu.Ft.)	OVERALL DIMENSIONS (inches)	WEIGHT PACKED (lbs.)
1	Portable Underwater Sound Testing Equipment Model OAX			190
1	Portable Underwater Sound Testing Equipment Model OAX-1			

EQUIPMENT SUPPLIED DATA

QUANTITY PER EQUIPT	NAME AND NOMENCLATURE	OVERALL DIMENSIONS (inches)	WEIGHT (lbs.)
	OAX		
1	Speaker-Amplifier Unit NT-50166 including: Carrying Case	8-3/4 X 13-3/4 X 18	49.5
1	Hydrophone NT-51061	2-1/2 dia X 13	8.5
1	External Attenuator, 20 DB	1-3/8 dia X 5	2.0
1	Set of Equipment Spares	9 X 12 X 18	29.0
1	Hydrophone Cable Assembly	720 lg	
1	Hydrophone Extension Cable Assembly	900 lg	
1	Power Cable Assembly	300 lg	
	OAX-1		
1	Portable Underwater Sound Testing Equipment Model OAX-1 consisting of:	11-1/8 X 15-5/8 X 18-3/4	66.0

UNCLASSIFIED

Test-Combination and Group

April 1958

PORTABLE UNDERWATER SOUND TESTING EQUIPMENT

OAX, OAX-1

EQUIPMENT SUPPLIED DATA

QUANTITY PER EQUIPT	NAME AND NOMENCLATURE	OVERALL DIMENSIONS (inches)	WEIGHT (lbs.)
1	Oscillator-Amplifier Unit NT-50175 Hydrophone Assembly NT-51065 Carrying Case NT-10299 Fixed Attenuator NT-632007 Hydrophone Cable Hydrophone Extension Cable Set of Equipment Spares	9-1/4 X 11 X 14-1/8 1-1/2 dia X 6 11-1/8 X 15-5/8 X 18-3/4 1-3/16 dia X 4 720 lg 900 lg	24.3

UNCLASSIFIED

4.10 OAX: 3

December 1956

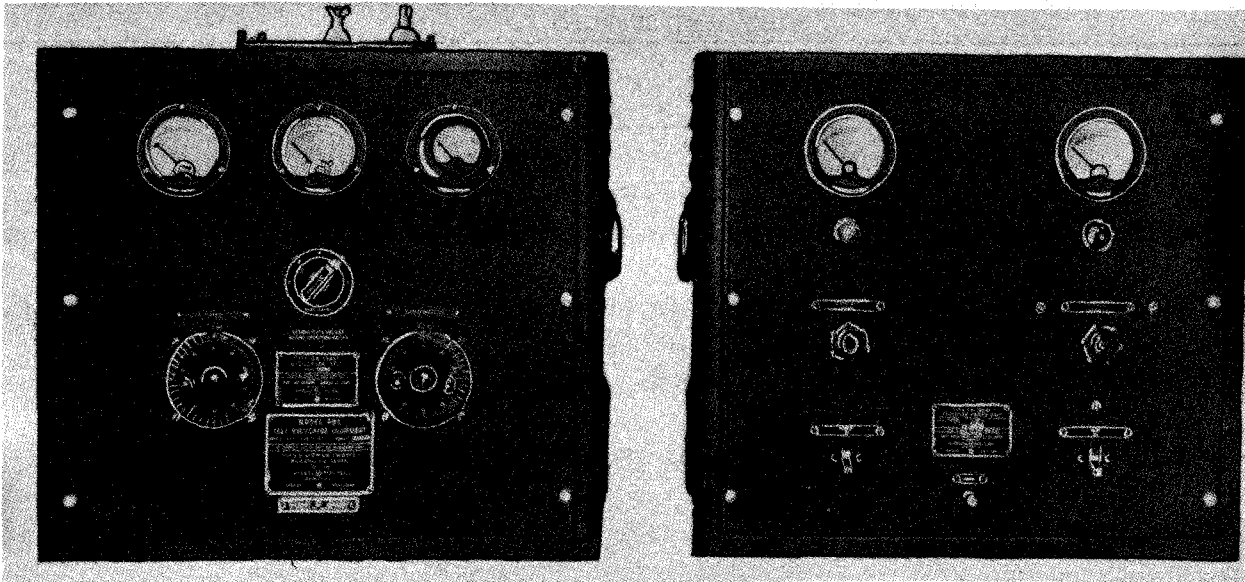
TEST OSCILLATOR EQUIPMENT**OBE***Test Oscillator Equipment OBE***FUNCTIONAL DESCRIPTION**

The OBE is designed as a portable unit to be used for making circuit adjustments and measurements of inductance, capacity and RF resistance of antennas, loading coils and ground systems operating in the frequency range of 40 to 200 kc.

No field changes in effect at time of preparation (21 June 1956).

ELECTRICAL AND MECHANICAL CHARACTERISTICS

FREQUENCY RANGE: 40 to 200 kc.
 OUTPUT IMPEDANCE: 1 to 10 ohms.
 OUTPUT POWER: 200 W into 10 ohms.
 INPUT: Approx. 600 W, 90% pf at max rated output.
 POWER REQUIREMENTS: 115 v, 50 to 60 cps, 600 W.

MANUFACTURER'S OR CONTRACTOR'S DATA

General Electric Co., Schenectady, N.Y.

Contract NXsy-27555, dated 2 October 1943.

TUBE AND/OR CRYSTAL COMPLEMENT

(2) 8005 (2) 866A
 Total Tubes: (4)

REFERENCE DATA AND LITERATURE

NAVSHIPS 900,312: Technical Manual for Test Oscillator Equipment OBE.

TYPE CLASSIFICATION	
DESIGN COGNIZANCE	BUSHIPS
PROCUREMENT COGNIZANCE	
STOCK NO.	
R.D.B. IDENT. NO.	

EQUIPMENT SUPPLIED DATA

QUANTITY PER EQUIPT	NAME AND NOMENCLATURE	OVERALL DIMENSIONS (inches)	WEIGHT (lbs.)
1	Oscillator Unit NT-35038	15 x 21-3/8 x 23	55
1	Rectifier Power Unit NT-20244	15 x 19-1/4 x 23	95
3	Cables w/Plugs		

March 1957

TEST SET ELECTRON TUBE

OCL

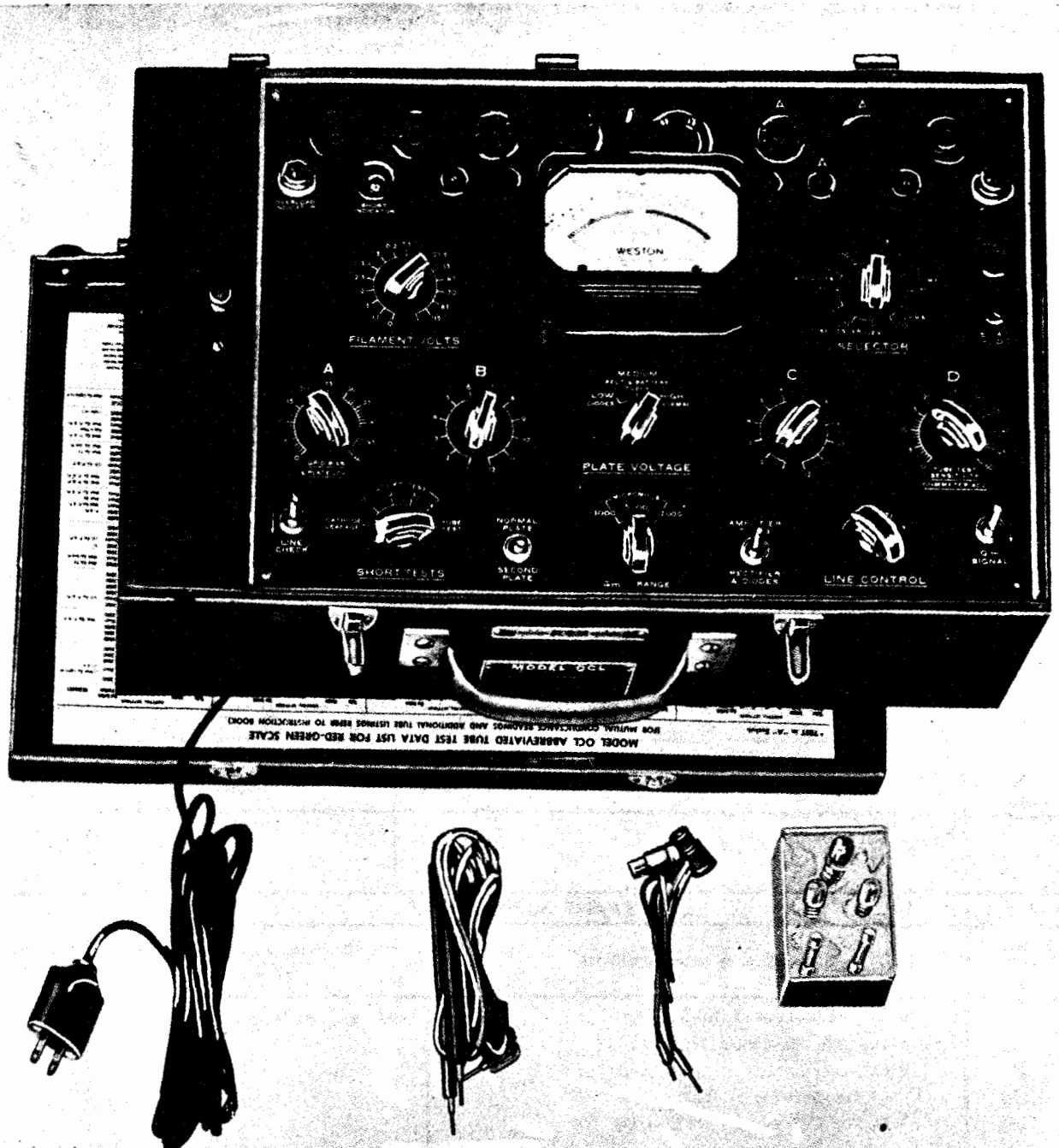

Test Set, Electron Tube OCL

FUNCTIONAL DESCRIPTION

The OCL is a portable, compact vacuum tube analyzing unit designed to measure the

transconductance values and indicate the quality of vacuum tubes.

A multimeter section, using the same indicator, is incorporated in this unit permitting measurement of AC and DC voltages, current and resistance.

UNCLASSIFIED

4.10 OCL: 1

OCL

TEST SET, ELECTRON TUBE

March 1957

No field changes in effect at time of preparation (16 August 1956).

Approximate Cost: \$260.00 with Equipment spares.

ELECTRICAL AND MECHANICAL CHARACTERISTICS

METER RANGES

MICROMHOS: 0 to 3000, 0 to 6000 and 0 to 12000.

AC AND DC VOLTS: 15 v DC, 150 v DC, 750 v DC, 15 v AC, 150 v AC and 750 v AC.

MILLIAMPS: 7.5 ma, DC and 150 ma DC.

OHMS: 100,000 ohms and 1 megohm.

SENSITIVITY: 1000 ohms per volt.

ACCURACY

MICROMHOS: ±15%.

DC VOLTS, MILLIAMPS AND OHMS: ±14%.

AC VOLTS: ±5%.

POWER SOURCE REQUIRED: 115 v, 60 cps, single ph, 30 W.

TUBE AND/OR CRYSTAL COMPLEMENT

(1) 3A4

Total Tubes: (2)

REFERENCE DATA AND LITERATURE

NAVSHIPS 900,807: Technical Manual for Vacuum Tube Testing Equipment Model OCL.

MANUFACTURER'S OR CONTRACTOR'S DATA

Weston Electrical Instrument Co., Newark NJ.

Contract NXsr-59069, dated 1 May 1944.

Approximate Cost: \$260.00 with equipment spares.

TYPE CLASSIFICATION
 DESIGN COGNIZANCE BUSHIPS
 PROCUREMENT COGNIZANCE
 STOCK NO.
 R.D.B. IDENT. NO.

SHIPPING DATA

NUMBER OF BOXES	CONTENTS AND IDENTIFICATION	VOLUME (Cu.Ft.)	OVERALL DIMENSIONS (inches)	WEIGHT PACKED (lbs.)
1	Test Set, Electron Tube-OCL			47

EQUIPMENT SUPPLIED DATA

QUANTITY PER EQUIPT	NAME AND NOMENCLATURE	OVERALL DIMENSIONS (inches)	WEIGHT (lbs.)
1	Test Set, Electron Tube-OCL	6-3/4 X 12-1/2 X 17-3/4	23
1	Set Accessories consisting of:		
1	Blacktop Connector Grid Lead for Tube Testing		
1	Red Top Connector Plate Lead for Tube Testing		
1	Pair-Test Leads for Voltage, Current and Resistance readings		
1	Line Cord (permanently attached)		
1	Set Operating Spare Parts		

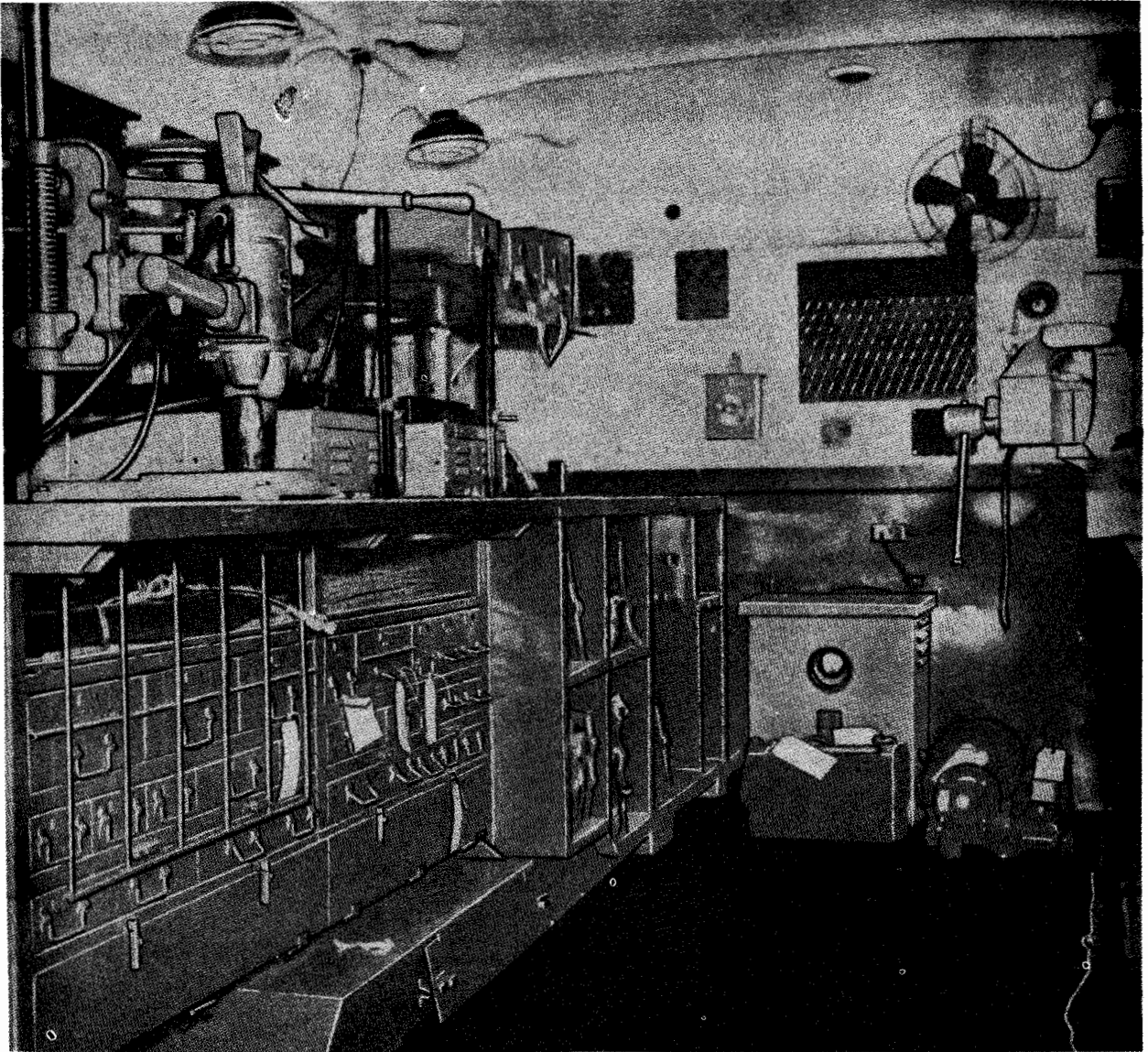
MOBILE ELECTRONIC REPAIR SHOP**OCM***Mobile Electronic Repair Shop OCM***FUNCTIONAL DESCRIPTION**

The OCM is a complete mobile, truck and trailer mounted, electronic repair shop capable of accomplishing intricate repairs and adjustments to electronic equipment at an advanced base.

The type K-53 truck and its body is heated and ventilated and contains a complete assortment of test equipments, service kits, tools, benches and materials as well as a radio transmitter-receiver to permit communications with home base.

The type K-52 trailer contains Power Unit PE-95-G, a 10 kw, 120 v gasoline engine generator.

No field changes in effect at time of preparation (11 April 1958).

RELATION TO OTHER EQUIPMENT

The OCM is a modified version of Signal Corps Repair Unit M-30 or M-31.

OCM MOBILE ELECTRONIC REPAIR SHOP

ELECTRICAL AND MECHANICAL CHARACTERISTICS

For the undermentioned tests and types of repair, the following types of instruments are included:

CURRENT MEASUREMENT: Ammeter, microammeter.

VOLTAGE MEASUREMENT: Voltmeter, vacuum tube voltmeter.

RESISTANCE MEASUREMENT: Ohmmeter, megohmmeter.

MAGNETIC FLUX MEASUREMENT: Fluxmeter.

FREQUENCY MEASUREMENT: Frequency meter, wave meter.

FREQUENCY CALIBRATION:

RF signal generators (HF, VHF, UHF, SHF).

AM and FM signal generators.

Audio signal generators.

Video signal generator.

Oscilloscopes.

GENERAL TESTS AND REPAIRS: Dummy antennas, test-toolkits, probes, tube testers, analyzers, signal tracers, indicators, cable splicing kit, terminal kit, battery charger, crystal rectifier test set, variac, electron tube adapter, capacitance and resistance bridge, drill, soldering iron, paint sprayer.

For communications purposes a TCS Radio Transmitting and Receiving Equipment is included.

FREQUENCY RANGE: 1.5 to 12 mc.

A1: 25 W.

A3: 10 W.

The PE-95-G trailer mounted Power Unit rated at 120 v, 60 cps, single phase, 10 kw supplies all the energy required for the operation of the unit.

MANUFACTURER'S OR CONTRACTOR'S DATA

Puget Sound Naval Shipyard, Bremerton, Wash.

Project Order 45708.

Approximate Cost: \$27000.00 with equipment spares.

TUBE AND/OR CRYSTAL COMPLEMENT

No Electron Tubes or Crystals used.

REFERENCE DATA AND LITERATURE

NAVSHIPS 91330: Technical Manual for Electronic Repair Truck Navy Model OCM.

TYPE CLASSIFICATION
DESIGN COGNIZANCE BUSHIPS
PROCUREMENT COGNIZANCE
STOCK NO.
R.D.B. IDENT. NO.

SHIPPING DATA

NUMBER OF BOXES	CONTENTS AND IDENTIFICATION	VOLUME (Cu.Ft.)	OVERALL DIMENSIONS (inches)	WEIGHT PACKED (lbs.)
	Modified Signal Corps Repair Unit M-30 or M-31 mounted in Army cargo truck		96 X 122 X 257	19970
	Trailer with Power Unit		72 X 76 X 144	3760

EQUIPMENT SUPPLIED DATA

QUANTITY PER EQUIPT	NAME AND NOMENCLATURE	OVERALL DIMENSIONS (inches)	WEIGHT (lbs.)
1	Type K-52 Trailer with PE-95-G Power Unit		
1	Truck Mounted, Modified Signal Corps Repair Unit M-30 or M-31		
	The following equipment is installed in the above vehicles:		
1	Ammeter, AC, 0-25 amp		
1	Ammeter, DC, 0/3/30/300 amp		
1	Microammeter NT-60107		
1	Vacuum Tube voltmeter, AC, Ballentine		

UNCLASSIFIED

April 1958

Test-Combination and Group

MOBILE ELECTRONIC REPAIR SHOP

OCM

EQUIPMENT SUPPLIED DATA

QUANTITY PER EQUIP	NAME AND NOMENCLATURE	OVERALL DIMENSIONS (inches)	WEIGHT (lbs.)
	Laboratories		
1	Megohmmeter NT-60089		
1	Ohmmeter Type G, battery operated		
1	Multimeter ME-25/U		
2	Multimeter TS-297/U		
1	Fluxmeter TS-15/AP		
1	Frequency Meter LM-18		
1	Test Set, Radar Model OAP		
1	Wavemeter NT-60ABM		
1	RF Signal Generator Model LP-5		
1	RF Signal Generator Type TS-35A/AP		
1	RF Signal Generator Sig Corps Type I-208		
1	Video Signal Generator Model OCD		
1	RF Signal Generator Model LAF		
1	RF Signal Generator TS-155C/UP		
1	UHF Signal Generator Model LX		
1	UHF Signal Generator Model LAE		
1	Audio Oscillator Model LAJ		
1	Oscilloscope Type OS-8/U		
1	Oscilloscope NT-60109		
1	Oscilloscope TS-34A/AP		
1	Emergency Electronic Repair kit NT-10223		
5	Dummy Antennas, 500 ohms 100 W, 73 ohms 100 W, 600 ohms 100 W, 73 ohms 250 W, 600 ohms 250 W		
3	Test Tool Set AN/USM-3		
1	Cable Splicing kit NT-10351		
2	Terminal kit NT-10498		
6	Patchcord, Coaxial NT-49123B		
1	voltage Divider TS-98/AP		
1	Battery Charger, 6 to 45 v DC output, 115 v AC operated		
1	Crystal Rectifier Test Set TS-268/U		
1	Variac 0 to 135 v output		
1	Tube Tester TV-3/U		
1	Electron Tube Adapter NT-49617		
1	Capacity and Resistance Bridge NT-60007		
1	Radio Transmitting and Receiving Equipment TCS-12		
1	Whip Antenna NT-66053		
1	Insulator Base NT-61428		
1	Insulator Pedestal NT-61339		
1	Mast Section MS-49		
1	Mast Section MS-50		

UNCLASSIFIED

4.10 OCM: 3

OCM

MOBILE ELECTRONIC REPAIR SHOP

EQUIPMENT SUPPLIED DATA

QUANTITY PER EQUIPT	NAME AND NOMENCLATURE	OVERALL DIMENSIONS (inches)	WEIGHT (lbs.)
1	Mast Section MS-51		
1	Mast Section MS-52		
1	Mast Section MS-53		
1	Mast Base MP-37		
1	Antenna Disconnect Switch NT-24206		
20	Technical Manuals Stocks of spares, tools, tubes, lamps, hardware, batteries, workshop equipment etc.		

April 1958

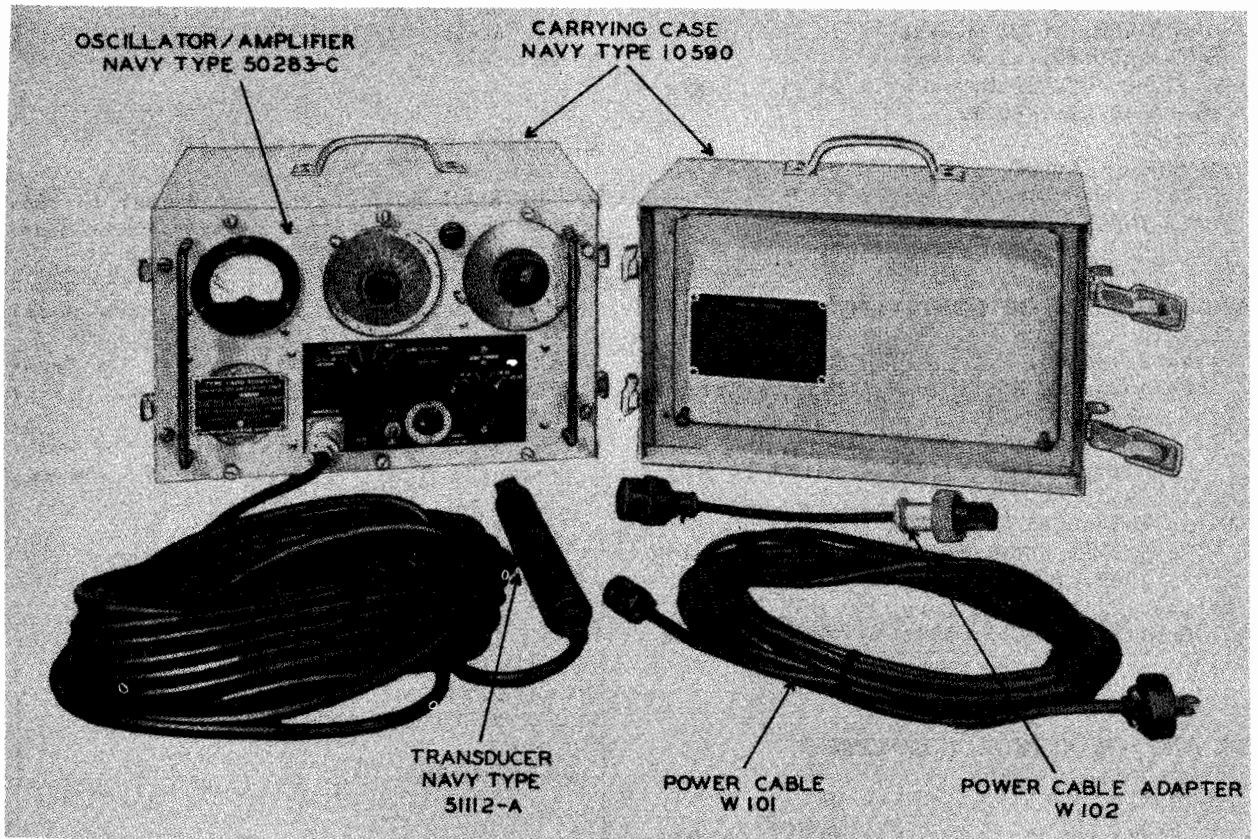
SONAR PORTABLE TESTING EQUIPMENT OCP-1, -2, -3, -4*Sonar Portable Testing Equipment OCP-1, -2, -3, -4***FUNCTIONAL DESCRIPTION**

The OCP-1, OCP-2, OCP-3, and OCP-4 is a portable underwater sound test equipment designed to generate and receive ultra-sonic signal energy at frequencies between 7 and 70 kc.

Signals of known frequency can be generated which have a fairly constant strength throughout the band. Relative power measurements can be made of signals radiated by ships sonar equipment. These signals can be converted into sound through a speaker. By beat frequency operation, the air frequency can also be measured. With its hydrophone, the equipment can be used for underwater test of various sonar equipments.

No field changes in effect at time of preparation (20 February 1958).

RELATION TO OTHER EQUIPMENT

Equipment Required but not Supplied: (1) Weight 25 to 50 lbs, (1) Secure line 30 to 50 ft lg.

ELECTRICAL AND MECHANICAL CHARACTERISTICS

FREQUENCY RANGE: 7 to 70 kc, nominal.

TUNING BANDS

BAND 1: 5 to 11 kc.

BAND 2: 10 to 22 kc.

BAND 3: 20 to 44 kc.

BAND 4: 40 to 88 kc.

TYPE FREQUENCY CONTROL: Manually controlled variable oscillator.

FREQUENCY STABILITY: Oscillator, accurate within 2% of dial markings from 0 to 50 deg C and line voltage from 100 to 130 v.

OUTPUT IMPEDANCE: 50 ohms.

Test-Combination and Group

OCP-1, -2, -3, -4 SONAR PORTABLE TESTING EQUIPMENT

April 1958

OUTPUT POWER

TO SPEAKER: 0.25 W max.

TO TRANSDUCER: 1 W max.

POWER SOURCE REQUIRED: 100 to 130 v, single phase, 60 cps, 60 W.

TRANSDUCER

IMPEDANCE INPUT: 27 +j 42.0 ohms at 30 kc.

POWER INPUT: 5 W max.

(1) OD3/VR150

(1) 5Y3GT

Total Tubes: (10)

No Crystals.

REFERENCE DATA AND LITERATURE

NAVSHIPS 900,811: Technical Manual for Sonar Portable Testing Equipment Navy Model OCP-1.

NAVSHIPS 91577: Technical Manual for Sonar Portable Testing Equipment Navy Model OCP-2.

NAVSHIPS 91601: Technical Manual for Sonar Portable Testing Equipment Navy Model OCP-3.

NAVSHIPS 92184: Technical Manual for Sonar Portable Testing Equipment Navy Model OCP-4.

MANUFACTURER'S OR CONTRACTOR'S DATA

David Bogen Co, N.Y., N.Y.

Contract: N5sr-760, dated 16 April 1945 (OCP-1)

Chatham Electronics Corp, Newark, N.J.

Contract: NObsr-49111, dated 15 May 1950. (OCP-2).

David Bogen Co, N.Y., N.Y.

Contract: NObsr-52512, dated 7 June 1952. (OCP-3).

Chatham Electronics Corp, Newark, N.J.

Contract: NObsr-59436 and 63147, dated 3 June 1953, (OCP-4).

TYPE CLASSIFICATION
 DESIGN COGNIZANCE BUSHIPS
 PROCUREMENT COGNIZANCE MIL-T-15866(SHIPS)
 STOCK NO.
 R.D.B. IDENT. NO.

TUBE AND/OR CRYSTAL COMPLEMENT

(5) 6SJ7

(1) 6H6

(1) 6V6GT

(1) 6SN7GT

SHIPPING DATA

NUMBER OF BOXES	CONTENTS AND IDENTIFICATION	VOLUME (Cu.Ft.)	OVERALL DIMENSIONS (inches)	WEIGHT PACKED (lbs.)
OCP-				
1	1	1	1	Carrying Case containing Transducers and Oscillator Amplifier w/cables
1	1	1	1	
1	Spare Parts Box			

EQUIPMENT SUPPLIED DATA

QUANTITY PER EQUIPT	NAME AND NOMENCLATURE	OVERALL DIMENSIONS (inches)	WEIGHT (lbs.)	
OCP-				
1	2	2	2	Transducer NT-51112
1	2	2	2	
1	Transducer NT-51112-A		2	

4.10 OCP-1: 2

UNCLASSIFIED

UNCLASSIFIED

Test-Combination and Group

April 1958

SONAR PORTABLE TESTING EQUIPMENT OCP-1, -2, -3, -4

EQUIPMENT SUPPLIED DATA

QUANTITY PER EQUIPT				NAME AND NOMENCLATURE	OVERALL DIMENSIONS (inches)	WEIGHT (lbs.)
1	2	3	4			
OCP-						
1				Oscillator Amplifier NT-50283	9-3/4 x 12 x 15	37.5
	1			Oscillator Amplifier NT-50283-A	9-3/4 x 12 x 15	37.5
		1		Oscillator Amplifier NT-50283-B	9-3/4 x 12 x 15	37.5
			1	Oscillator Amplifier NT-50283-C	9-3/4 x 12 x 15	37.5
1	1	1	1	Carrying Case NT-10590	9-3/4 x 15 x 20-3/8	13.0
1	1	1	1	Extension Cable W-201	900 lg	4
1	1	1	1	Power Cable W-101	300 lg	1.5
1	1	1	1	Power Cable Adapter W-102	8 lg	0.75
1				Spare Parts Box	9-1/2 x 12-1/2 x 18-1/2	65

UNCLASSIFIED

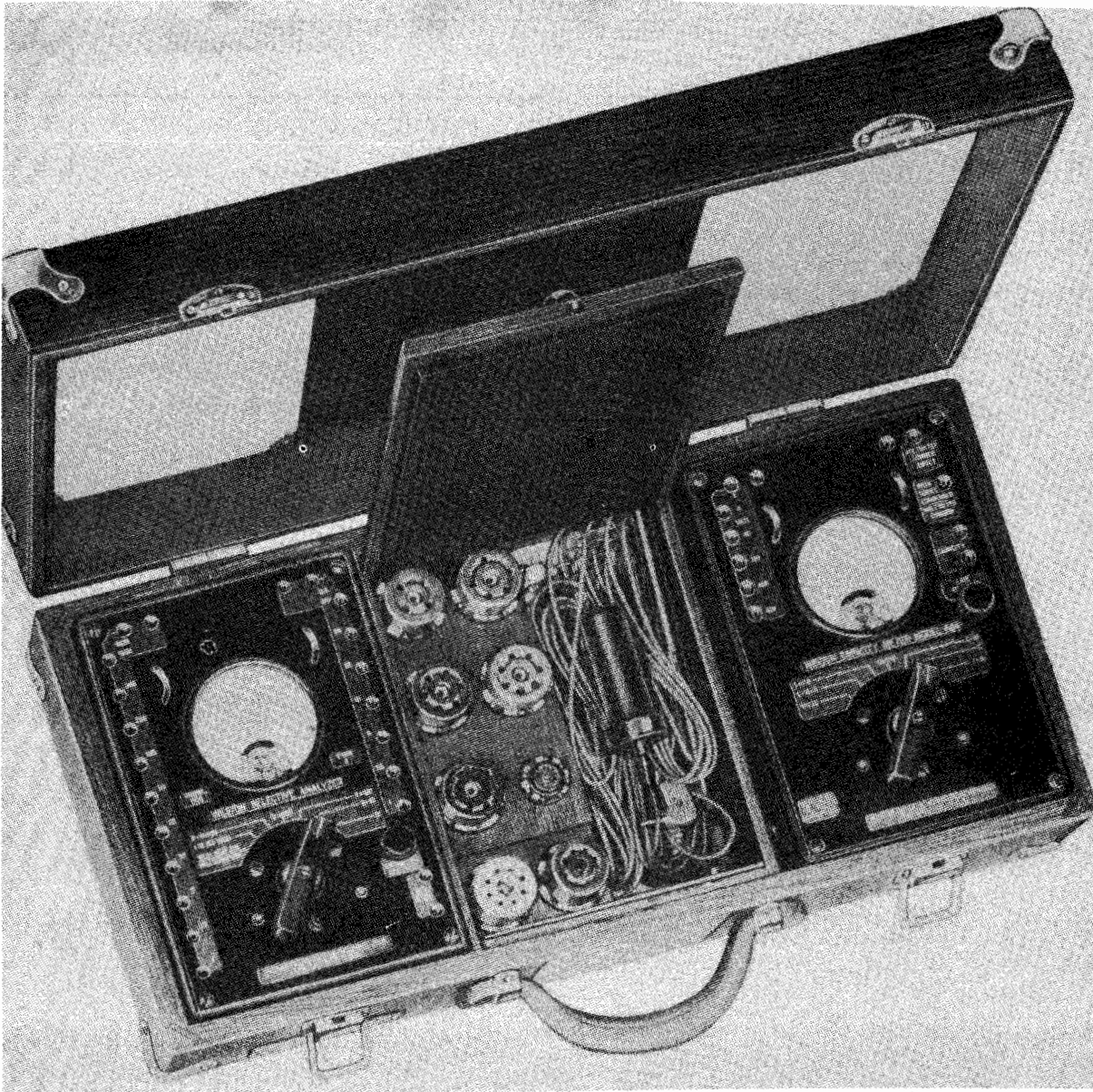
**RADIO RECEIVER ANALYZING OE,OE-1 THRU OE-13
EQUIPMENT**

Radio Receiver Analyzing Equipment OE thru OE-12

FUNCTIONAL DESCRIPTION

The models OE, OE-1 thru OE-13 are each a group of voltage and current measuring instruments with accessories, contained in a portable wooden case. Static measurements of

voltages, currents, resistances and capacitance associated with various radio circuits are made by electrical indicating instruments. Socket and plug adapters are utilized to permit a combination of selective analysis and point to point testing of electronic equipments quickly and conveniently.

June 1957

Test-Combination and Group

OE,OE-1 THRU OE-13 RADIO RECEIVER ANALYZING EQUIPMENT

The various models of the OE series are identical electrically and in application but differ principally in the quantity and type of plug and socket adapters furnished. There are also some physical differences in minor component parts.

The model OE is supplied with adapters for four to seven prong tubes, the models OE-1 thru OE-5 with adapters for four to eight prong tubes and the models OE-6 thru OE-11 with adapters for four to eight prong tubes and miniature tubes. Improved adapters and omission of the test block are features of the model OE-12 and OE-13.

No field changes in effect at time of preparation (25 October 1956).

POWER SOURCE REQUIRED: 115 v, 60 cps, single ph 7 W and 15 v DC.

MANUFACTURER'S OR CONTRACTOR'S DATA

Weston Electrical Instrument Corp, Newark, N.J.

Contract NOs 39103, dated 3 November 1934.

Contract N 140S-68858, dated 25 November 1936.

Contract NOs 56258, dated 11 August 1937.

Contract NOs 71780, dated 15 February 1940.

Contract NXss/A 13581, dated 30 September 1942.

Contract NXss/20398, NXss/31232, dated 12 June 1943.

Contract NOa(s) 2226 and NXsr 41024, dated 17 December 1943.

RELATION TO OTHER EQUIPMENT

Similar to Weston model 790 Radio Receiving Analyzing Equipment except that model 790 does not employ a tube adapter block.

ELECTRICAL AND MECHANICAL CHARACTERISTICS

DC VOLT-OHM-MILLIAMMETER

SENSITIVITY: 20000 ohms per v on 200 v range, 1000 ohms per v on 500 and 1000 v range.

ACCURACY: $\pm 2.5\%$.

VOLTAGE RANGES: 0 to 1, 2.5, 5, 10, 25, 50, 100, 250, 500 and 1000 v.

CURRENT RANGES: 0 to 1, 2.5, 5, 10, 25 and 100 ma.

RESISTANCE RANGES: 0 to 1000, 10000, 100000 ohms and 1 to 10 megs.

AC VOLT-CAPACITY METER

SENSITIVITY: 1000 ohms per v.

ACCURACY: $\pm 5\%$.

VOLTAGE RANGES: 0 to 4, 8, 40, 200, 400 and 800 v.

CAPACITY MEASUREMENT RANGE: 100 uuf to 200 uuf in 5 steps.

TUBE AND/OR CRYSTAL COMPLEMENT

No Electron Tubes.

REFERENCE DATA AND LITERATURE

Technical Manual for Radio Receiver Analyzing Equipment OE, OE-1 thru OE-13.

TYPE CLASSIFICATION	
DESIGN COGNIZANCE	BUSHIPS
PROCUREMENT COGNIZANCE	
STOCK NO.	
R.D.B. IDENT. NO.	

EQUIPMENT SUPPLIED DATA

QUANTITY PER EQUIPT	NAME AND NOMENCLATURE	OVERALL DIMENSIONS (inches)	WEIGHT (lbs.)
1	Carrying Case	5-5/8 X 11-3/8 X 18-5/8	19-1/4
1	DC Volt/Ma/Ohm Meter NT-22193	3-3/16 X 5-1/2 X 8-1/4	5-1/4
1	AC Volt/Capacity Meter NT-22194	3-3/16 X 5-1/2 X 8-1/4	4
*1	Circuit Analyzer Assembly NT-60001		
**1	Circuit Analyzer Assembly NT-60005		
***1	Circuit Analyzer Assembly NT-60034		
+1	4 Prong Adapter NT-49514		
+1	5 Prong Adapter NT-49515		
+1	6 Prong Adapter NT-49516		
+1	7 Prong Adapter NT-49517		

UNCLASSIFIED

June 1957

Test-Combination and Group

RADIO RECEIVER ANALYZING OE,OE-1 THRU OE-13 EQUIPMENT

EQUIPMENT SUPPLIED DATA

QUANTITY PER EQUIPT	NAME AND NOMENCLATURE	OVERALL DIMENSIONS (inches)	WEIGHT (lbs.)
+1	7 Prong Adapter NT-49527		
+++1	Octal Adapter NT-49518-A		
+1	Loktal Adapter NT-49528		
+1	Miniature Adapter NT-49519		
++1	Octal Adapter NT-49518		
	*Model OE only		
	**Models OE-1 thru OE-5 only		
	***Models OE-6 thru OE-11 only		
	+Models OE-12 and OE-13 only		
	++Model OE-12 only		
	+++Model OE-13 only		

UNCLASSIFIED

4. 10 OE: 3

UNCLASSIFIED

March 1957

Test Combination and Group

RADIO TUBE TEST EQUIPMENT

OZ, OZ-1, 2

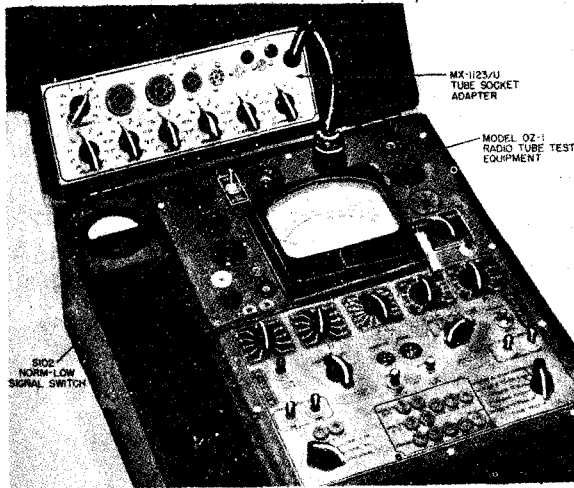

OZ Series Vacuum Tube Testing Equipment

FUNCTIONAL DESCRIPTION

The OZ, OZ-1, and OZ-2 are used to measure the dynamic mutual conductance of vacuum tubes. In addition they are used to measure voltage, current, resistance, capacity, inductance, and to detect gas leakage, noise and shorts or opens in vacuum tubes. An electronic rectifier is used for alternating current measurements. The analyzer is independent of the tube tester section.

Data on this sheet reflects the following field changes, FC-1 (1 August 1956).

RELATION TO OTHER EQUIPMENT

The OZ, OZ-1 and OZ-2 are similar to Hickok Electrical Instrument Co. Model 550.

ELECTRICAL AND MECHANICAL CHARACTERISTICS

TUBE TESTER SECTION: Accepts 4 pins, 5 pin,

6 pin, 7 pin, large or small, 8 pin octal or octal, 7 pin miniature, and acorn tubes.

ANALYZER SECTION

AC AND DC VOLTAGE RANGE: 0 to 1000 v
±2-1/2% at 1000 ohm/v..

RESISTANCE RANGE: 0.1 ohms to 25 meg.

CAPACITANCE RANGE: 0.0001 to 24 uf.

MILLIAMPERE RANGE: 0 to 200.

DECIBEL RANGE: -10 to -21 db.

INDUCTANCE RANGE: 0.3 to 70 henries.

MICROHMS RANGE: 0 to 15,000.

OPERATING POWER: 95 to 115 v, 60 cps, 1 ph,
45 W.

MANUFACTURER'S OR CONTRACTOR'S DATA

The Hickok Electrical Instrument Company,
Cleveland, Ohio.

Contract NObsr 43350, dated 23 May
1949.

Approximate Cost: \$94.00 with
equipment spares.

TUBE AND/OR CRYSTAL COMPLEMENT

(1) 5W4/5W4GT/5Y3 (1) 83 (1) 6H6/6H6GT

Total Tubes: (3)

REFERENCE DATA AND LITERATURE

NAVSHIPS 95198-1, 900,346-1B-2, 95200-1:
Technical Manual for Vacuum Tube Testing
Equipment OZ, OZ-1 and OZ-2.

TYPE CLASSIFICATION
DESIGN COGNIZANCE BUSHIPS
PROCUREMENT COGNIZANCE
STOCK NO.
R.D.B. IDENT. NO.

SHIPPING DATA

NUMBER OF BOXES	CONTENTS AND IDENTIFICATION	VOLUME (Cu.Ft.)	OVERALL DIMENSIONS (inches)	WEIGHT PACKED (lbs.)
1ea	Radio Test Tube OZ, OZ-1, 2	226		3-1/2

UNCLASSIFIED

4.10 OZ: 1

OZ,OZ-1,2

RADIO TUBE TEST EQUIPMENT

March 1957

EQUIPMENT SUPPLIED DATA

QUANTITY PER EQUIPT	NAME AND NOMENCLATURE	OVERALL DIMENSIONS (inches)	WEIGHT (lbs.)
1	Tube Tester and Multimeter OZ, OZ-1 and OZ-2 consisting of:		
1	Tube Socket Adapter MX-1123/U	1-3/4 x 3-9/16 x 10	1lb 5oz
1	Switch Assembly	3/4 x 1-1/2 x 1-7/8	1 oz.
2	Supplement to Technical Manuals NAVSHIPS-95198, 900,346-1B, and 95200		

UNCLASSIFIED

October 1957

POWER SUPPLY AND R.F. SIGNAL GENERATOR

Test-Combination and Group
PP-427/U,
SG-22/U

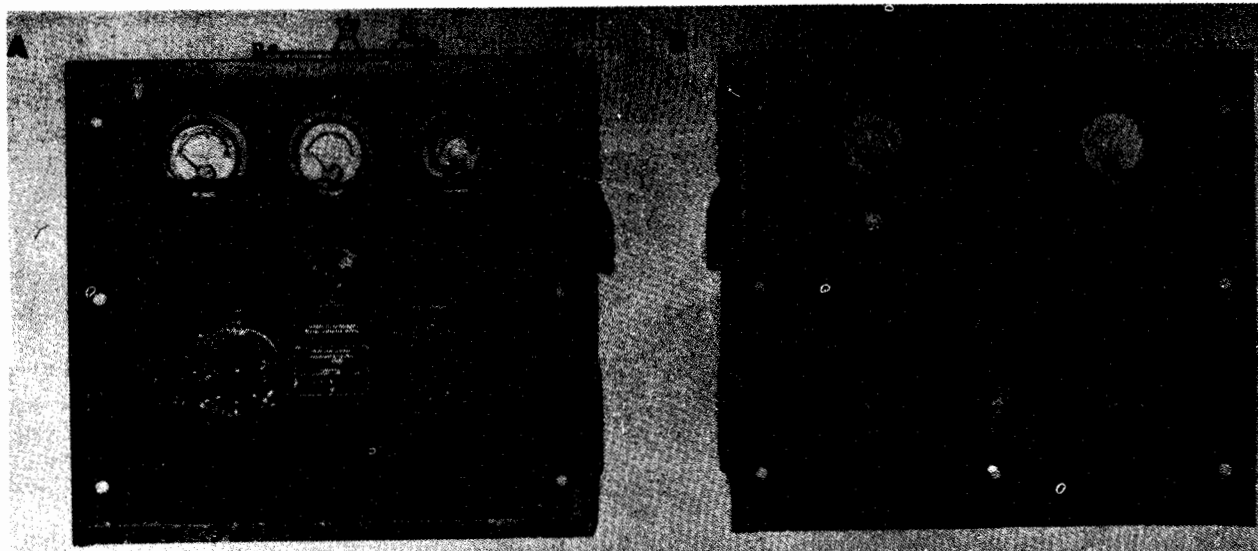

Power Supply, R.F. Signal Generator PP-427/U, SG-22/U

FUNCTIONAL DESCRIPTION

The PP-427/U and SG-22/U is a portable apparatus for making circuit adjustments and measurements of inductance, capacitance, and r-f resistance of antennas, loading coils, and ground systems at low-frequency Naval Radio Shore Stations.

No field changes in effect at time of preparation (21 March 1957).

RELATION TO OTHER EQUIPMENT

The PP-427/U and SG-22/U is identical to the Model OBE, except for minor differences in the components used in the equipment.

ELECTRICAL AND MECHANICAL CHARACTERISTICS

FREQUENCY RANGE: 40 to 200 kc.
POWER OUTPUT: 200 w.
INPUT: 600 w at 90% pf.
POWER SUPPLY INPUT: 115 v, 50 to 60 cps,
single ph.

MANUFACTURER'S OR CONTRACTOR'S DATA

General Electric Co., Syracuse, N.Y.
Contract NObsr-39343

TUBE AND/OR CRYSTAL COMPLEMENT

(2) 8005 (2) 3B28

Total Tubes: (4)

REFERENCE DATA AND LITERATURE

NAVSHIPS 91170: Technical Manual for RF SIGNAL GENERATOR SG-22/U AND POWER SUPPLY PP-427/U.

TYPE CLASSIFICATION
DESIGN COGNIZANCE BUSHIPS
PROCUREMENT COGNIZANCE
STOCK NO.
R.D.B. IDENT. NO.

UNCLASSIFIED

4.10 PP-427/U: 1

UNCLASSIFIED

Test-Combination and Group
 PP-427/U,
 SG-22/U

**POWER SUPPLY AND
 RF SIGNAL GENERATOR**

October 1957

SHIPPING DATA

NUMBER OF BOXES	CONTENTS AND IDENTIFICATION	VOLUME (Cu.Ft.)	OVERALL DIMENSIONS (inches)	WEIGHT PACKED (lbs.)
1	RF Signal Generator SG-22/U	20	30 X 34 X 34	283
1	Power Supply PP-427/U	20	30 X 34 X 34	300
1	Spare Parts	14.1	17 X 20 X 30	80
1	Set Electronic Tubes	3.1	13 X 17 X 24	25

EQUIPMENT SUPPLIED DATA

QUANTITY PER EQUIPT	NAME AND NOMENCLATURE	OVERALL DIMENSIONS (inches)	WEIGHT (lbs.)
1	RF Signal Generator SG-22/U	20-1/4 X 21-3/8 X 23	80
1	Power Supply PP-427/U	19-1/4 X 20-1/4 X 23	150
1	Spare Parts	13 X 14-1/2 X 22-1/8	55
1	Set Electronic Tubes	10 X 12 X 15	3

UNCLASSIFIED

UNCLASSIFIED

April 1958

Test-Combination and Group

WAVE AND POWER METER SET

TS-107/TPM-1

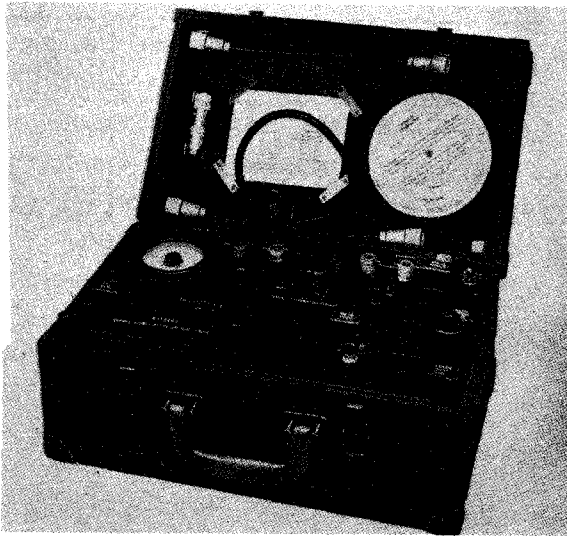

Wave and Power Meter Set TS-107/TPM-1

ELECTRICAL AND MECHANICAL CHARACTERISTICS

FREQUENCY RANGE: 500 to 1,500 mc ± 3 mc.
 TYPE OF RECEPTION: CW, MCW, pulse.
 POWER MEASURING RANGE: 0.5 to 120 mw (-3 to +21 dbm) w/accessory attenuator.
 CURRENT RANGE: 0 to 15 ma.
 IMPEDANCE: 50 ohms (input).
 TEMPERATURE RANGE: -10 deg F to +120 deg F.
 ACCURACY: ± 0.5 db (relative power); ± 1 db (absolute power).
 POWER REQUIREMENTS: Battery, 4.5 v DC, 0.25 W.

MANUFACTURER'S OR CONTRACTOR'S DATA

Western Electric Co., New York, N.Y.
 Contract AF 14589, dated 29 June 1950.
 Contract NOrd-3456, dated 2 February 1945.
 Contract NOrd-10095, dated 27 June 1947.
 Order No. 195-MPD-43.

FUNCTIONAL DESCRIPTION

The TS-107/TPM-1 is a portable unit used in measuring or checking the frequency of radio transmitter, signal generators, and beat-frequency oscillators. It will also measure the average power of CW, MCW or pulsed radar sets and provide a video output signal for testing oscilloscopes.

No field changes in effect at time of preparation (15 April 1958).

RELATION TO OTHER EQUIPMENT

Equipment Required but not Supplied: (3)
 Battery BA-27.

TUBE AND/OR CRYSTAL COMPLEMENT

No Electron Tubes used.

(1) 1N21B
 Total Crystals: (1)

REFERENCE DATA AND LITERATURE

NAVSHIPS 900,454A: Handbook of Maintenance Instructions for Wave and Power Meter Set TS-107/TPM-1.

TYPE CLASSIFICATION

DESIGN COGNIZANCE BUORD

PROCUREMENT COGNIZANCE Navy Spec OS-3087, USAF
 STOCK NO. Spec 371-5080

R.D.B. IDENT. NO.

SHIPPING DATA

NUMBER OF BOXES	CONTENTS AND IDENTIFICATION	VOLUME (Cu.Ft.)	OVERALL DIMENSIONS (inches)	WEIGHT PACKED (lbs.)
1	Wave and Power Meter TS-107/TPM-1 (w/accessories)	1.38	11 X 12 X 18	26

UNCLASSIFIED

4.10 TS-107/TPM-1: 1

April 1958

Test-Combination and Group

TS-107/TPM-1

WAVE AND POWER METER SET

EQUIPMENT SUPPLIED DATA

QUANTITY PER EQUIPT	NAME AND NOMENCLATURE	OVERALL DIMENSIONS (inches)	WEIGHT (lbs.)
1	Wave and Power Meter Set TS-107/TPM-1 including:	7-3/16 X 9-9/16 X 14-3/4	18
1	Connecting Cable CG-311/U	12 lg	
1	Connecting Cable CG-311/U	25 lg	
1	Frequency Calibration Card		
1	10 db Pad X-664558		
1	Allen Wrench No. 8		
1	Spare Thermistor		
1	Spare Crystal		

December 1956

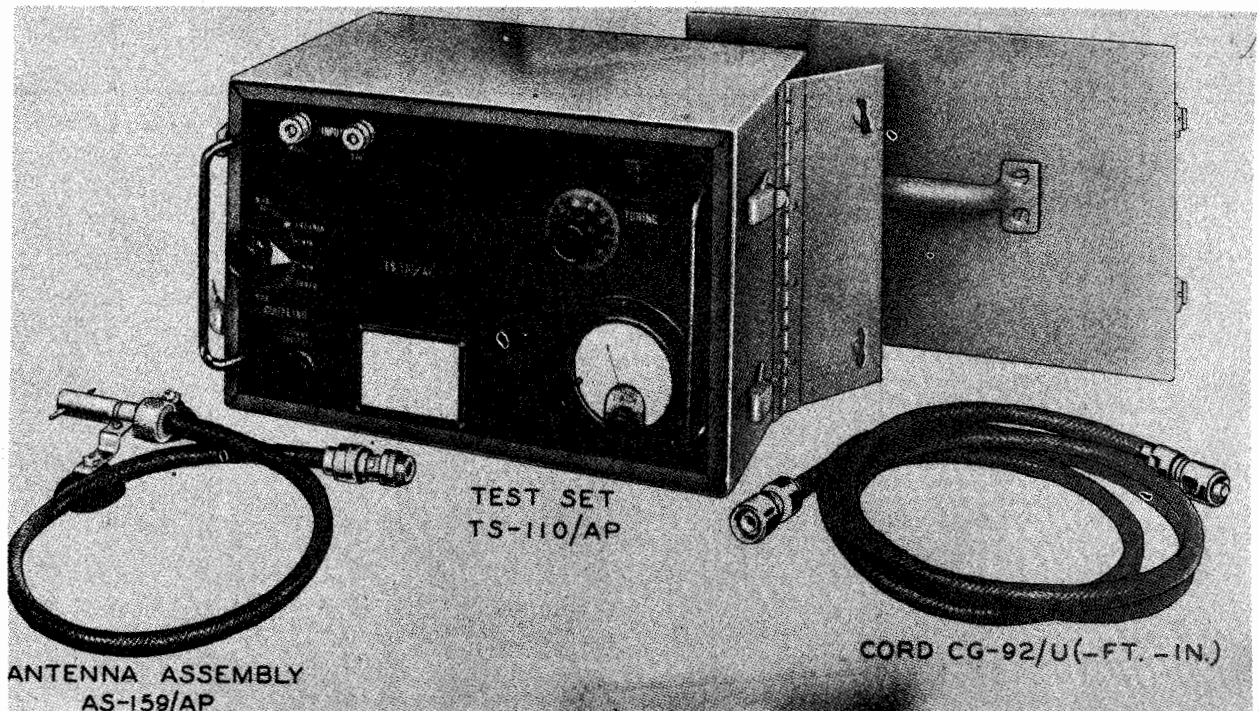
TEST SET**TS-110/AP***Test Set TS-110/AP***FUNCTIONAL DESCRIPTION**

The TS-110/AP is a portable ringing cavity resonator for checking over-all performance of an airborne radar system, rough measurement of the power output of the radar transmitter, rough spectrum analysis, checks for multiple moding the radar transmitter, checking the power level and frequency of a radar-receiver local oscillator to within ± 5 mc and checking the speed of recovery of a radar T-R box and receiver. This set requires no external power supply and this is well adapted for use at advanced field bases.

No field changes in effect at time of preparation (22 June 1956).

RELATION TO OTHER EQUIPMENT

Similar to Test Set TS-61/AP.

ELECTRICAL AND MECHANICAL CHARACTERISTICS

FREQUENCY RANGE: 2400 to 2700 mc.
 Q FACTOR: 30000 to 40000.
 RINGTIME: 20 to 25 usec, or 2 to 2.5 statute mi.

IMPEDANCE: 50 ohms.

MANUFACTURER'S OR CONTRACTOR'S DATA

Western Electric Co., New York, N.Y.
 Order No. 2048-ARL-44.

TUBE AND/OR CRYSTAL COMPLEMENT

(1) CRYSTAL
 Total Crystals: (1)

REFERENCE DATA AND LITERATURE

AN-16-35TS61-2: Technical Manual for Test Set TS-110/AP.

TYPE CLASSIFICATION DESIGN COGNIZANCE USAF PROCUREMENT COGNIZANCE STOCK NO. R.D.B. IDENT. NO.

UNCLASSIFIED

TS-110/AP

TEST SET

December 1956

EQUIPMENT SUPPLIED DATA

QUANTITY PER EQUIPT	NAME AND NOMENCLATURE	OVERALL DIMENSIONS (inches)	WEIGHT (lbs.)
1	Test Set TS-110/AP	7-31/32 X 10-5/8 X 11-11/16	9
1	Antenna Assembly AS-159/AP	4-1/2 X 27-7/8	0.5
1	Connecting Cord CG-92/U	25/32 X 76-1/4	0.9

TEST SET

TS-120/UP,
TS-191/UP

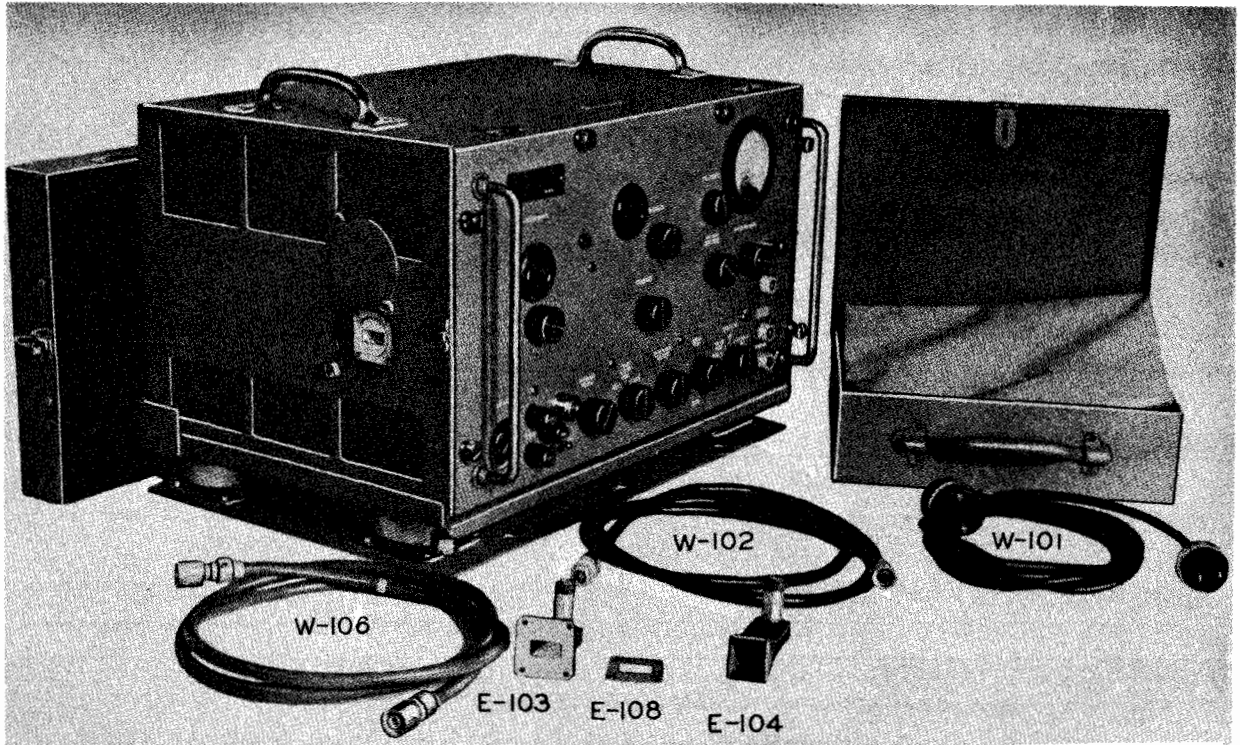

Test Set TS-120/UP

FUNCTIONAL DESCRIPTION

The TS-120/UP and TS-191/UP are portable signal generators used in measuring and adjusting radar and radar-beacon equipment. Functioning as signal generators, frequency meters, and wattmeters, they measure output frequency, power, local oscillator frequency, receiver sensitivity, and IF bandwidth of radar sets and radar-beacon equipments.

No field changes in effect at time of preparation (17 April 1958).

PULSE DELAY: 10 to 200 usec, variable.
POWER INPUT: 5 to 32 db above 1 mw.
PULSE OUTPUT: 0 to 75 db below 1 mw.
PULSE WIDTH: 0.2 to 5.0 usec, variable; 1 to 2 usec, fixed.
SYNCHRONIZATION: 25 to 200 v (pos trigger); 30 to 200 v (neg trigger).
VIDEO OUTPUT: 10 to 15 v (neg) amplitude.
POWER REQUIREMENTS: 80 v or 115 v $\pm 10\%$, 50 to 800 cps, single ph.

RELATION TO OTHER EQUIPMENT

These equipments supersede Radio Frequency Test Set TS-13/AP for beacon use.

MANUFACTURER'S OR CONTRACTOR'S DATA

Airadio Inc, Stamford, Conn.
Contract NXsr-44551, NXsr-60003, dated May 1944. (TS-120/UP).
Contract NXsr-69247, dated 24 July 1944. (TS-191/UP).
Approximate Cost: \$2,500.00 with equipment spares.

ELECTRICAL AND MECHANICAL CHARACTERISTICS

FREQUENCY RANGE: 8,990 to 9,170 mc (TS-191/UP); 9,825 to 9,465 mc (TS-120/UP).
TYPE OF EMISSION: CW, pulse, square wave.
MODULATION FREQUENCY: 1,250 cps, square wave.

TUBE AND/OR CRYSTAL COMPLEMENT

(2) OC3 (1) 5R4GY (2) 6AC7

April 1958

Test-Combination and Group

**TS-120/UP,
TS-191/UP****TEST SET**

(1) 6AG5 (1) 6SH7 (2) 6SN7
 (1) 6X5GT (1) 6Y6G (1) 723A/B
 (2) 2050

Total Tubes: (14)

No Crystals used.

REFERENCE DATA AND LITERATURE

SHIPS 386: Technical Manual for Test Set
 TS-120/UP and TS-191/UP.

TYPE CLASSIFICATION
 DESIGN COGNIZANCE BUSHIPS
 PROCUREMENT COGNIZANCE USN Spec RE9514B
 STOCK NO.
 R.D.B. IDENT. NO.

SHIPPING DATA

NUMBER OF BOXES	CONTENTS AND IDENTIFICATION	VOLUME (Cu.Ft.)	OVERALL DIMENSIONS (inches)	WEIGHT PACKED (lbs.)
1	Test Set TS-120/UP or TS-191/UP (w/accessories)	7.19	20 X 23 X 27	170
1	Metal spare-Parts Box	4.43	16 X 19-3/8 X 24-5/8	110

EQUIPMENT SUPPLIED DATA

QUANTITY PER EQUIPT	NAME AND NOMENCLATURE	OVERALL DIMENSIONS (inches)	WEIGHT (lbs.)
1	Test Set TS-120/UP or TS-191/UP including:	13-1/8 X 16-1/4 X 21-5/8	60
1	Shock-mount cradle (supplied with some equipments)	3-1/2 X 14-1/4 X 21-3/8	12
1	Accessories Box containing:	3-1/2 X 12-1/8 X 12-1/4	12.7
1	Video Cable assy W-102	72 lg	
1	RF Coaxial-Cable Assy W-106	72 lg	
1	Adapter NT-491427		
1	Adapter E-108		
1	Pick-up Horn AT-68/UP		
1	Power Cord Assy W-101	102 lg	
1	Technical Manual		
1	Metal Spare-parts Box containing:	12-1/4 X 16-3/16 X 19-3/8	70
1	Set Equipment Spare Parts		

December 1956

TEST SET

TS-13/AP

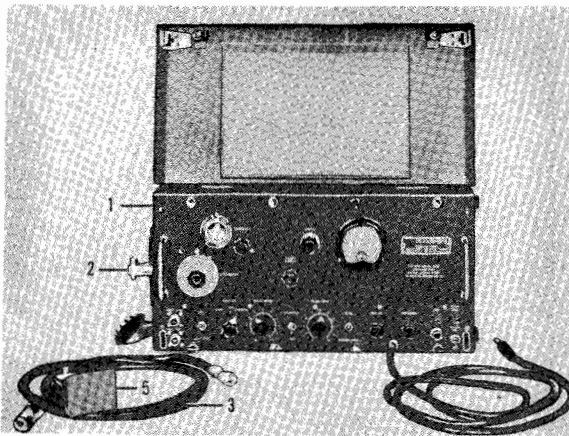

Test Set TS-13/AP

FUNCTIONAL DESCRIPTION

The TS-13/AP is designed for bench and field testing of X-band radars. It tests power output, transmitter frequency signal-to-noise ratio, IF bandpass and provides a signal for receiver tuning. It may also be used for standard signal generator tests.

No field changes in effect at time of preparation (18 June 1956).

ELECTRICAL AND MECHANICAL CHARACTERISTICS

FREQUENCY RANGE: 9305 to 9445 mc.
 SIGNAL OUTPUT: 0 to 50 uw (cw at PRF of 1000 cps) 250 uw peak power.
 PULSE WIDTH: 1 to 2 usec.
 PULSE PHASING: 6 to 200 usec.
 CALIBRATED ATTENUATOR: 13 to 65 dbm.
 ACCURACY
 FREQUENCY: ± 2 mc/sec.

POWER MONITOR: ± 1 db.
 SIGNAL INPUT: Positive trigger pulses not less than 15 v and 1 to 20 usec long.
 Negative trigger pulses not less than 50 v.
 SENSITIVITY: Power meter, 50 mw for half scale meter deflection.
 INTERNAL SYNCHRONIZATION: 1000 cps.
 POWER REQUIREMENTS: 105 to 120 v, 60 to 800 cps, 150 W.

MANUFACTURER'S OR CONTRACTOR'S DATA

Presto Recording Corp., New York, N.Y.
 Contract NXss-33647.
 Approximate Cost: \$2000.

TUBE AND/OR CRYSTAL COMPLEMENT

(3) 6SN7 (2) 6AC7 (1) 5Y3GT
 (1) 6Y6 (1) 5U4G (3) OC3/VR-105
 (1) 723-AB(2K25)
 Total Tubes: (12)

REFERENCE DATA AND LITERATURE

NAVAER 08-5S-78: Technical Manual of Test Equipment for Airborne Electrical and Electronic Equipment.

TYPE CLASSIFICATION	
DESIGN COGNIZANCE	BUSHIPS
PROCUREMENT COGNIZANCE	
STOCK NO.	
R.D.B. IDENT. NO.	

EQUIPMENT SUPPLIED DATA

QUANTITY PER EQUIPT	NAME AND NOMENCLATURE	OVERALL DIMENSIONS (inches)	WEIGHT (lbs.)
1	RF Test Set TS-13/AP including:		
1	Waveguide UG-81/U.	10-1/2 x 11-1/2 x 21	73
1	RF Cable RG-9/U with UG-24/U connectors.		
1	Sync Cable RG-11/U with NT-49195 connectors.		
1	Pickup Horn AT-48/UP.		
1	Spare Parts Box.		
1	Technical Manual AN16-35TS13-3.		

TEST SET

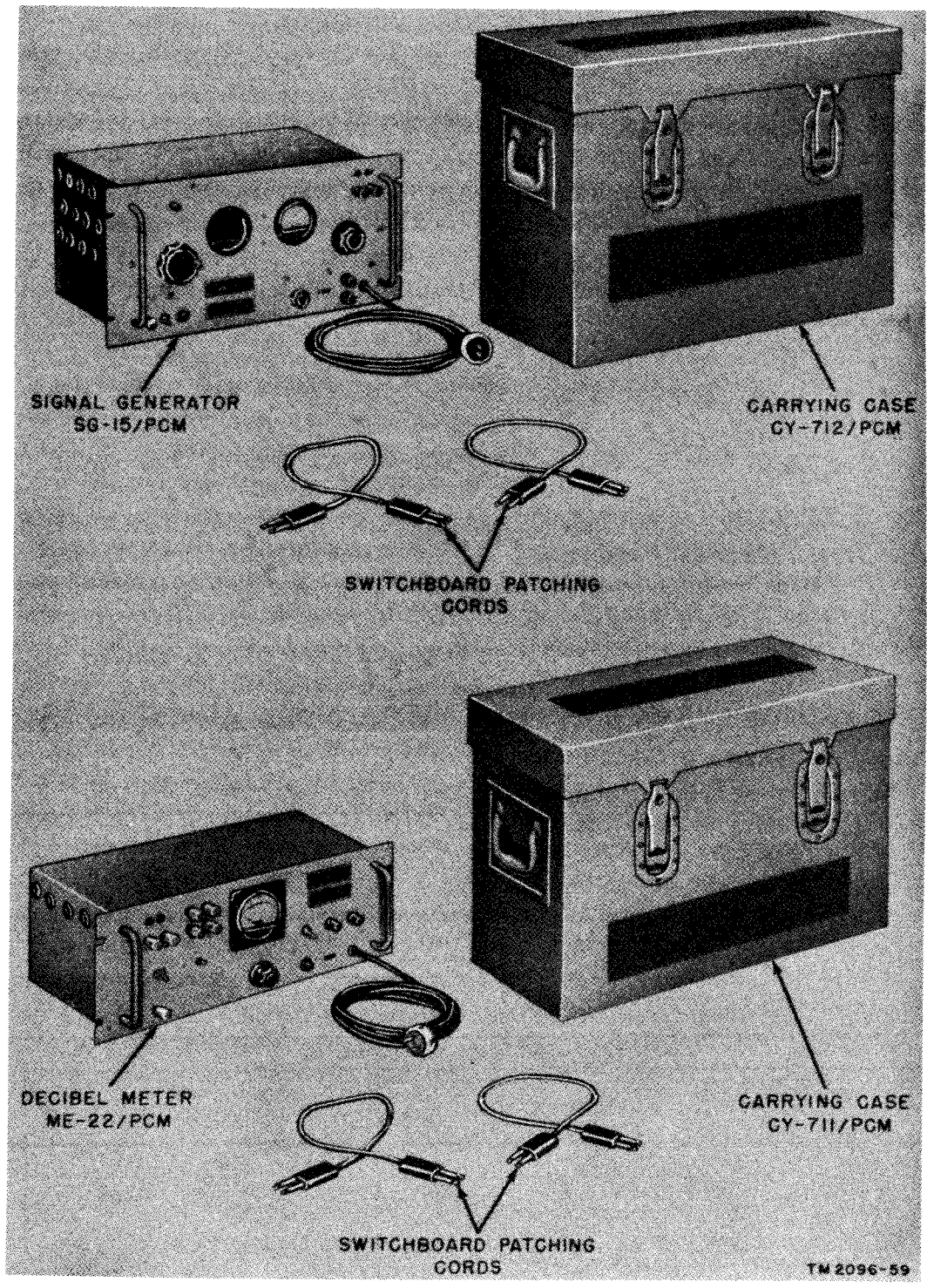

TM 2096-59

Test Set TS-140/PCM

August 1957

Test-Combination and Group

TS-140/PCM**TEST SET****FUNCTIONAL DESCRIPTION**

The TS-140/PCM, which consists of Signal Generator SG-15/PCM and Decibel Meter ME-22/PCM is a portable test set designed for making transmission measurements of voice frequency and carrier equipment in the frequency range of 200 cycles through 35 kilocycles. It also is used for testing wire and cable lines to determine their suitability for use with such equipment in communication systems. Gain and loss may be measured directly by Test Set TS-140/PCM since the front panel controls, and meters of both the signal generator and the decibel meter, indicate power levels in dbm (decibels referred to 1 milliwatt in 600 ohms). Cross talk also may be measured by using the gain and loss measurement technique and making measurements through the entire frequency range of the equipment or wire line under test.

No field changes in effect at time of preparation (7 January 1957).

ELECTRICAL AND MECHANICAL CHARACTERISTICS**SIGNAL GENERATOR SG-15/PCM**

FREQUENCY RANGE: 200 through 35000 cps.

FREQUENCY ACCURACY: ± 10 cps in range from 200 through 1000 cps; ± 20 cps in range from 1000 through 2000 cps; ± 50 cps in range from 2000 through 35000 cps.

POWER OUTPUT: -54 dbm through +26 dbm $\pm .5$ db.

OUTPUT IMPEDANCE: 600 ohms $\pm 5\%$ at 1000 cps and 600 ohms, $\pm 10\%$ at all other frequencies.

POWER SOURCE REQUIRED: 115 or 230 V, 50 to 70 cps, single ph, 50 W.

DECIBEL METER ME-22/PCM

RANGE: -45 to +25 dbm.

ACCURACY: $\pm .5$ db in frequency range from 200 to 35000 cps when calibrated at 1000 cps

METER SCALES

SCALE A: 0 to +15 db.

SCALE B: -15 to 0 db.

INPUT IMPEDANCE: 600 or 8000 ohms

POWER SOURCE REQUIRED: 115 or 230 v, 50 to 70 cps, single ph, 50 W.

TUBE AND/OR CRYSTAL COMPLEMENT

(3) 6J5 (1) 6SL7GT (2) 6V6GT
(5) 6SJ7 (1) 6SA7Y (2) 6SQ7
(2) OC3/VR-105 (2) 6L6GAY (2) 5Y3GT

Total Tubes: (20)

REFERENCE DATA AND LITERATURE

TM11-2096, TO16-35TS140-5, Technical Manual for Test Set TS-140/PCM, Signal Generator SG-15/PCM and Decibel Meter ME-22/PCM.

TYPE CLASSIFICATION
DESIGN COGNIZANCE TASSA
PROCUREMENT COGNIZANCE
STOCK NO.
R.D.B. IDENT. NO.

SHIPPING DATA

NUMBER OF BOXES	CONTENTS AND IDENTIFICATION	VOLUME (Cu.Ft.)	OVERALL DIMENSIONS (inches)	WEIGHT PACKED (lbs.)
1	Signal Generator SG-15/PCM c/o 1 Power Cord Switchboard Patching Cords 2 Technical Manuals	2.69	12-7/8 X 16-15/16 X 21-3/8	90
1	Decibel Meter ME-22/PCM	2	11 X 15-1/16 X 21-3/8	56

UNCLASSIFIED

August 1957

Test-Combination and Group

TEST SET

TS-140/PCM

EQUIPMENT SUPPLIED DATA

QUANTITY PER EQUIPT	NAME AND NOMENCLATURE	OVERALL DIMENSIONS (inches)	WEIGHT (lbs.)
1	Signal Generator SG-15/PCM c/o	8-3/4 X 13 X 19	52
	1 Carrying Case CY-712/PCM	12-1/4 X 16 X 21-1/8	30
	2 Switchboard Patching Cords	24 lg.	
	1 Set of Spare Fuse and Tubes		
1	Decibel Meter ME-22/PCM c/o	7 X 10-5/8 X 19	25
	1 Carrying Case CY-711/PCM	10-7/8 X 14-1/4 X 21	25
	2 Switchboard Patching Cord	24 lg	
	1 Set of Spare Fuse and Tubes		

UNCLASSIFIED

UNCLASSIFIED

April 1958

Test-Combination and Group

TEST SET

TS-146/UP

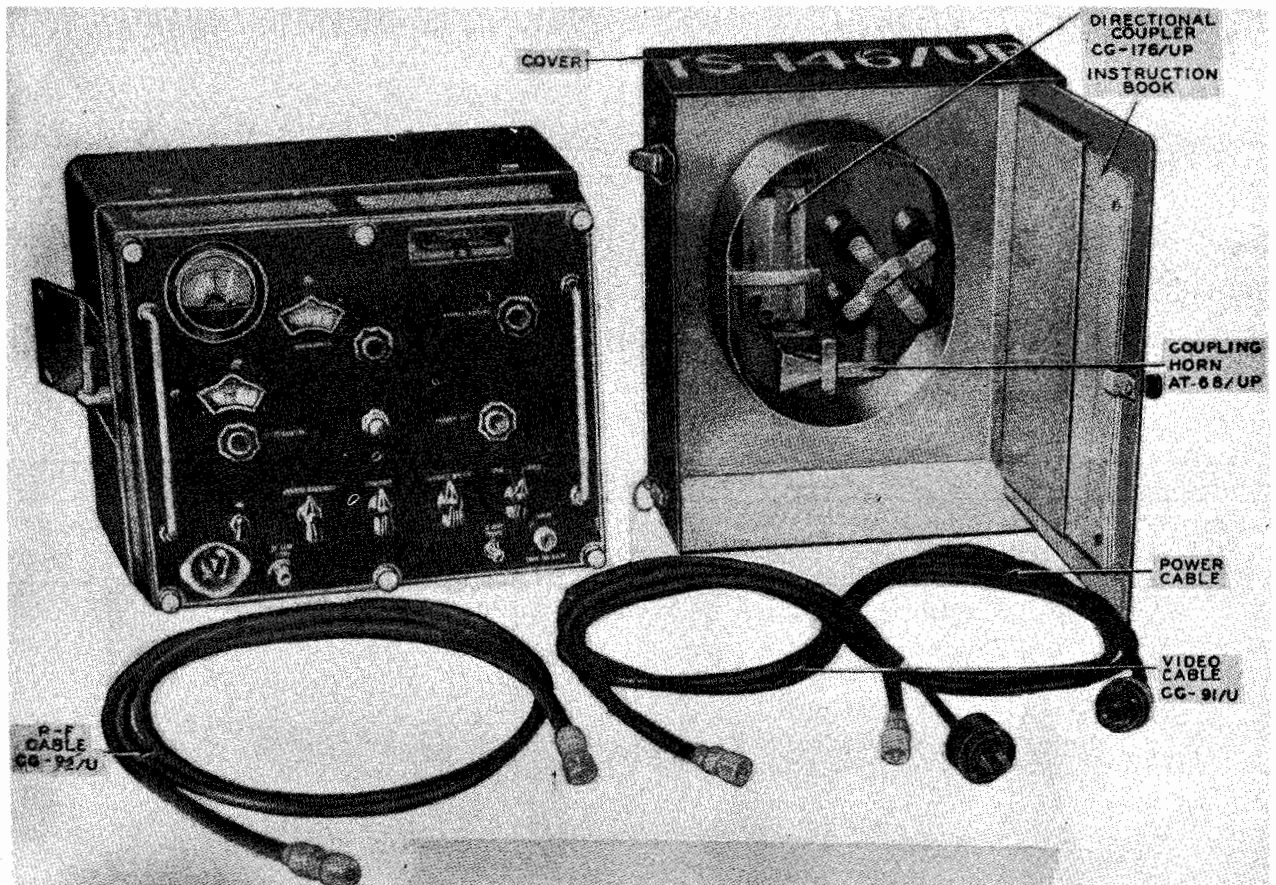

Test Set TS-146/UP

FUNCTIONAL DESCRIPTION

The TS-146/UP is an FM field unit in measuring the power output and frequency of radar transmitters, as well as the sensitivity of radar receivers. In conjunction with an oscilloscope, this equipment is used in tuning radar receivers and TR boxes, measuring transmitter spectrum width and receiver bandwidth, determining TR box recovery time, checking magnetron pulling and AFC circuits, and tuning radar local oscillators.

No field changes in effect at time of preparation (17 April 1958).

RELATION TO OTHER EQUIPMENT

Equipment Required but not Supplied: (1)

Oscilloscope TS-34/AP or equivalent.

ELECTRICAL AND MECHANICAL CHARACTERISTICS

FREQUENCY RANGE: 9,285 to 9,465 mc ± 2 mc.

POWER RANGE: 1 W (avg); 8 to 500 W (peak).

IMPEDANCE: 50 ohms (input).

ACCURACY: ± 2 db (pwr).

POWER REQUIREMENTS: 115 v, 50 to 1,200 cps, 60 W.

MANUFACTURER'S OR CONTRACTOR'S DATA

Philharmonic Radio Corp, New York, N.Y.

Contract NOas-3195.

Approximate Cost: \$1,413.00 with equipment spares.

UNCLASSIFIED

4.10 TS-146/UP: 1

April 1958

Test-Combination and Group

TS-146/UP**TEST SET****TUBE AND/OR CRYSTAL COMPLEMENT**

Instructions for Test Set TS-146/UP.

(3) OD3 (1) 5R4GY
 (1) 723A/B (1) 884

Total Tubes: (6)

No Crystals used.

REFERENCE DATA AND LITERATURE

CO-AN08-35TS146-2: Handbook of Maintenance

TYPE CLASSIFICATION
DESIGN COGNIZANCE BUAER
PROCUREMENT COGNIZANCE
STOCK NO.
R.D.B. IDENT. NO.

EQUIPMENT SUPPLIED DATA

QUANTITY PER EQUIPT	NAME AND NOMENCLATURE	OVERALL DIMENSIONS (inches)	WEIGHT (lbs.)
1	Test Set TS-146/UP including:	9-1/2 X 12 X 13-1/2	35
1	Pick-up Antenna AT-68/UP	1-1/16 X 2-3/16 X 3-11/32	
1	Cable, video CG-91/U	72 lg	
1	Cable, R-F coaxial CG-92/U	96 lg	
1	Cable, Power CX-337/U	120 lg	
1	Directional coupler CG-176/UP	2-5/16 X 2-3/8 X 5	

UNCLASSIFIED

April 1958

Test-Combination and Group

**TEST SET TS-147/UP,-147A/UP,-147B/UP,
-147C/UP,-147D/UP**

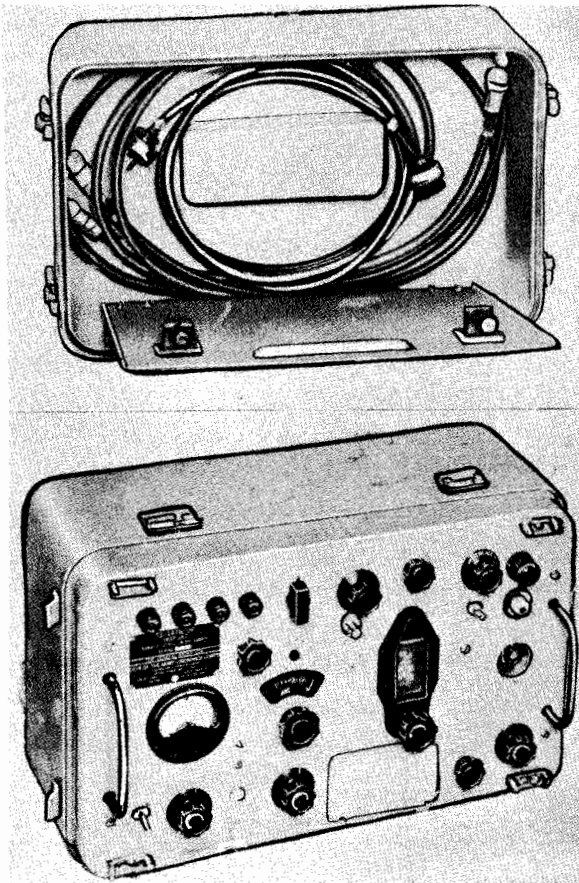

Test Set TS-147B/UP

FUNCTIONAL DESCRIPTION

The TS-147/UP; TS-147A/UP, TS-147B/UP, TS-147C/UP, and TS-147D/UP are portable microwave signal generators used for testing and adjusting beacon equipment and radar systems that operate within the frequency band of 8500 to 9600 megacycles.

They provide microwave test signals, either continuous-wave or frequency-modulated, of known power level and frequency. These signals, together with the aid of an A-type scan oscilloscope for observing the radar video output, can be used in visual alignment methods of adjusting radar systems. They contain a direct reading frequency meter and a power level meter to permit measurement of both the frequency and power level of input or output signals without the aid of accessory equipment.

The TS-147/UP series equipments are basically the same. The TS-147B/UP and TS-147D/UP differ from the series in that they contain provisions to allow for external modulation to produce a pulsed RF signal while the other models have no provision for external modulation.

No field changes in effect at time of preparation (2 January 1958).

RELATION TO OTHER EQUIPMENT

Equipment Required but not Supplied: (1) Oscilloscope TS-34/AP series or TS-239/UP series or equivalent as Required, (1) Directional Coupler CU-205/U or CU-206/U or CG-176/AP or equivalent as Required.

ELECTRICAL AND MECHANICAL CHARACTERISTICS

FREQUENCY RANGE: 8500 to 9600 mc.

FREQUENCY METER DATA

ACCURACY

ABSOLUTE: ± 2.5 mc at 25 deg C and 60% relative humidity.

RELATIVE: ± 1.0 mc for frequency increments of less than 60 mc.

CALIBRATION POINT: 9310 ± 1 mc at 25 deg C and 60% relative humidity, 9300 ± 1 mc at 25 deg C and 60% relative humidity.

POWER METER DATA

INPUT SIGNALS (AVERAGE POWER LEVEL)

RANGE: +7 to +30 dbm.

ACCURACY

TS-147/UP, -147A/UP, -147C/UP: ± 2.0 db.

TS-147B/UP, -147D/UP: ± 1.5 db.

OUTPUT TEST SIGNALS (PEAK MODE POWER)

RANGE

TS-147/UP: -40 to -80 dbm.

TS-147A/UP: -7 to -80 dbm.

TS-147B/UP: -42 to -85 dbm.

TS-147C/UP: -42 to -83 dbm.

TS-147D/UP: -7 to -85 dbm.

ACCURACY

TS-147/UP, -147A/UP, -147C/UP: ± 2.0 db.

TS-147B/UP, -147D/UP: ± 1.5 db.

SIGNAL GENERATOR DATA

FREQUENCY MODULATION

SWEEP RATE: 0 to 6 mc per usec.

PHASE RANGE: 3 to 50 usec after trigger.

FREQUENCY EXCURSION OF SWEEP: 0 to over 60 mc, 0 to over 40 mc for TS-147D/UP.

TRIGGERS REQUIRED

RF TRIGGER

POWER: 5 to 500 W peak.

PULSE REPETITION RATE: 3000 pps max for TS-147/UP, TS-147A/UP and TS-147C/UP; 4000 pps max for TS-147B/UP and TS-147D/UP.

UNCLASSIFIED

4.10 TS-147/UP: 1

Test-Combination and Group

**TS-147/UP,-147A/UP,-147B/UP, TEST SET
-147C/UP,-147D/UP**

April 1958

PULSE DURATION: 0.5 to 6 usec for TS-147/UP and TS-147A/UP, 0.2 to 6 usec for TS-147B/UP and TS-147D/UP, 0 to 6 usec for TS-147C/UP.

RISE TIME: Less than 0.5 usec.

VIDEO TRIGGER

POLARITY: Positive.

AMPLITUDE: 10 to 50 v peak.

DURATION: 0.5 to 20 usec at 10% of max amplitude.

RISE TIME: Less than 0.5 usec between 10% and 90% of max amplitude points.

SAWTOOTH SWEEP

AMPLITUDE: 0 to 100 v, negative polarity.

SLOPE: 0 to +2 v per usec, positive slope.

TRIGGER AMPLIFIER GAIN: Approx 500.

POWER REQUIREMENTS: 115 v \pm 10%, 50 to 1600 cps, single ph, 125 W.

TUBE AND/OR CRYSTAL COMPLEMENT

TS-147/UP, -147A/UP, -147C/UP, -147D/UP
(2) OC3W (1) 2K25 (1) 5R4WGB
(1) 6SH7 (2) 6SL7WGT (1) 6Y6G
Total Tubes: (8)

(1) 1N23B
Total Crystals: (1)

TS-147B/UP
(2) OB2WA (1) 2K25 (1) 5R4WGB
(1) 6SH7 (2) 6SL7WGT (1) 6Y6G
Total Tubes: (8)

(1) 1N23B
Total Crystals: (1)

REFERENCE DATA AND LITERATURE

TM11-1247: Technical Manual for Test Set TS-147/UP.

NAVSHIPS 91104: Technical Manual for Test Set TS-147A/UP.

NAVSHIPS 91956: Technical Manual for Radar Test Set TS-147B/UP.

NAVSHIPS 91692: Technical Manual for Test Set TS-147C/UP.

TM11-1247B: Technical Manual for Test Set TS-147D/UP.

MANUFACTURER'S OR CONTRACTOR'S DATA

Sperry Gyroscope Company, Great Neck, N.Y.
Contract NXsa-51553 (TS-147/UP).

Contract NObsr-57580, dated 30 June 1952 (TS-147B/UP).

GENERAL COMMUNICATION COMPANY, Boston, Mass.

Contract NObsa-39114, dated 25 February 1947 (TS-147A/UP).

Contract NObsr-39296, dated 25 June 1947 (TS-147A/UP).

Contract NObsr-52607, dated 25 June 1951 (TS-147D/UP).

Contract NObsr-57567, dated 30 June 1952 (TS-147D/UP).

Espey Manufacturing Company, Inc, New York, N.Y.

Contract NObsr-49265, dated 16 June 1952 (TS-147C/UP).

Approximate Cost: \$1480.00 with equipment spares.

TYPE CLASSIFICATION
DESIGN COGNIZANCE BUSHIPS
PROCUREMENT COGNIZANCE MIL-T-15254A(SHIPS)
STOCK NO.
R.D.B. IDENT. NO. 10.1.3

SHIPPING DATA

NUMBER OF BOXES	CONTENTS AND IDENTIFICATION	VOLUME (Cu.Ft.)	OVERALL DIMENSIONS (inches)	WEIGHT PACKED (lbs.)
1	TS-147/UP Test Set TS-147/UP TS-147A/UP Not Available TS-147B/UP	2.68	12-3/4 X 16 X 22-3/4	65
1	TS-147B/UP Test Set TS-147B/UP TS-147C/UP	6.2	19-1/2 X 19-1/2 X 28-1/8	65
1	TS-147C/UP Test Set TS-147C/UP TS-147D/UP	3.45	15-1/2 X 17 X 22-1/2	55
1	TS-147D/UP Test Set TS-147D/UP	3.7	15-1/2 X 17 X 24-1/4	76

UNCLASSIFIED

Test-Combination and Group

April 1958

TEST SET TS-147/UP,-147A/UP,-147B/UP,
-147C/UP,-147D/UP

EQUIPMENT SUPPLIED DATA

QUANTITY PER EQUIPT	NAME AND NOMENCLATURE	OVERALL DIMENSIONS (inches)	WEIGHT (lbs.)
	TS-147/UP		
1	Test Set TS-147/UP	11 X 12-1/4 X 18-3/4	35.0
1	Pick-Up Antenna AT-68/UP	2-1/4 X 4-1/2 X 6-3/4	0.14
1	Cable Assembly CG-92/U	96 lg	1.25
1	Cable Assembly CG-91/U	72 lg	1.25
1	Cable Assembly CX-337/U	72 lg	0.13
1	Adapter M-359		0.07
1	Set of Equipment Spares		
2	Technical Manual TM11-1247	1/4 X 7-3/4 X 10-1/4	
	TS-147A/UP		
1	Test Set TS-147A/UP	11 X 12-1/4 X 18-3/4	35.0
1	Pick-Up Antenna AT-68/UP	2-1/4 X 4-1/2 X 6-3/4	0.14
1	Cable Assembly CG-92B/U	96 lg	1.25
1	Cable Assembly CG-91/U	72 lg	1.25
1	Connector NT-49192	5/8 X 1-3/16 X 1-7/32	
1	Cable Assembly CX-337/U	72 lg	0.13
1	Set of Equipment Spares		
2	Technical Manual NAVSHIPS 91104	3/8 X 8-1/2 X 11	
	TS-147B/UP		
1	Test Set TS-147B/UP	11-27/32 X 13-3/8 X 19-1/8	35.0
1	Pick-Up Antenna AT-68/UP	2-1/4 X 4-1/2 X 6-3/4	0.14
1	Cable Assembly CG-92A/U	96 lg	1.25
1	Cable Assembly CG-409B/U	72 lg	1.25
1	Connector UG-306/U		
1	Cable Assembly CX-337/U	72 lg	0.13
1	Adapter UG-273/U	9/16 dia X 1-5/16	0.2
1	Adapter UG-397/U		0.2
1	Adapter UG-446/U		0.2
1	Set of Equipment Spares		
2	Technical Manual NAVSHIPS 91956	1/2 X 9 X 11-1/2	
	TS-147C/UP		
1	Test Set TS-147C/UP	11-7/8 X 12-13/16 X 19-1/2	35.0
1	Pick-Up Antenna AT-68/UP	2-1/4 X 4-1/2 X 6-3/4	0.14
1	Cable Assembly CG-92A/U	96 lg	1.25
1	Cable Assembly CG-638/U	72 lg	
1	Cable Assembly CX-337/U	72 lg	0.13
1	Right Angle Adapter NT-49192A	5/8 X 1-3/16 X 1-7/32	
1	Set of Equipment Spares		
2	Technical Manual NAVSHIPS 91692	1/2 X 8-1/2 X 11	
	TS-147D/UP		
1	Test Set TS-147D/UP	11-7/8 X 13 X 19-1/2	47.0
1	Pick-Up Antenna AT-68/UP	2-1/4 X 4-1/2 X 6-3/4	0.14
1	Cable Assembly CG-530/U	72 lg	0.7
1	Cable Assembly CG-92A/U	96 lg	1.0
1	Cable Assembly CX-337/U	72 lg	0.5
1	Adapter UG-273/U	9/16 dia X 1-5/16	0.2
1	Adapter UG-397/U		0.2
1	Adapter UG-446/U		0.2
1	Set of Equipment Spares		
2	Technical Manual TM11-1247B	1/4 X 8-1/2 X 11	

UNCLASSIFIED

4.10 TS-147/UP:

October 1957

Test-Combination and Group

SIGNAL GENERATOR**TS-155D/UP****FUNCTIONAL DESCRIPTION**

The TS-155D/UP is designed to be used as a signal generator to check the sensitivity of radar receivers, or as a power monitor to check the power output of radar transmitters. It can also be used as an uncalibrated absorption type frequency meter. It features different pulse input circuit to permit multiple pulsing and variable spacing between pulsing and an attenuator calibrated for power measurement at 2800, 3000, and 3300 megacycles.

No field changes in effect at time of preparation (11 July 1957).

RELATION TO OTHER EQUIPMENT

The TS-155D/UP is the same as and interchangeable with TS-155C/UP except for design changes, and is similar to earlier models of the TS-155 ()/UP series.

ELECTRICAL AND MECHANICAL CHARACTERISTICS

FREQUENCY RANGE: 2700 to 3400 mc.

INTERNAL MODULATION: variable between 120 to 2000 cps.

POWER REQUIREMENTS: 110 v, 50 to 1200 cps.

MANUFACTURER'S OR CONTRACTOR'S DATA

Boonton Radio Corporation, Boonton, N.J.

TUBE AND/OR CRYSTAL COMPLEMENT

(1) 9C3W

(1) 5Y3WGTB

(1) 0D3W

(1) 6AG7Y

(1) 2C40

(4) 6SN7WGTA

Total Tubes: (9)

(1) 1N21B

Total Crystals: (1)

REFERENCE DATA AND LITERATURE

Nomenclature Card for Signal Generator TS-155D/UP.

TYPE CLASSIFICATION DESIGN COGNIZANCE TASSA PROCUREMENT COGNIZANCE STOCK NO. R.D.B. IDENT. NO.

EQUIPMENT SUPPLIED DATA

QUANTITY PER EQUIPT	NAME AND NOMENCLATURE	OVERALL DIMENSIONS (inches)	WEIGHT (lbs.)
1	Signal Generator TS-155D/UP including: Cable Assemblies and Adapters	10 x 10 x 17	
1	Antenna		
2	Technical Manual		

June 1957

Combination and Group

TS-159/TPX

RADIO TEST SET

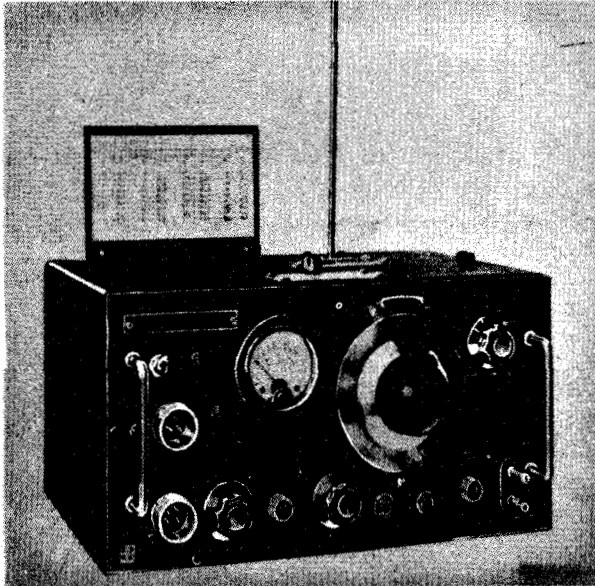

Radio Test Set TS-159/TPX

FUNCTIONAL DESCRIPTION

The TS-159/TPX is a combination test set which consists of a signal generator, a frequency meter, an audio amplifier, a power meter, and a voltmeter. A tuning chart and a removable test antenna are mounted on the top of the instrument.

It is used to test, tune, and align the circuits of Radar Sets AN/TPX-3 and AN/TPX-4, but can also be used with any other radar or radio equipment which has ranges within the limits of the test set. It is also used to measure currents and voltages within the IFF transmitter-receiver units.

No field changes in effect at time of preparation (27 Sept 1956).

ELECTRICAL AND MECHANICAL CHARACTERISTICS

RF RANGE

SIGNAL GENERATOR: 150 to 200 mc.

FREQUENCY METER: 150 to 200 mc.

CALIBRATION POINTS: 150, 160, 170, 180, 190 and 200 mc.

IF SIGNAL OUTPUT

FREQUENCY: 30 mc.

AMPLITUDE: 0 to 200000 v.

POWER MEASUREMENT

INPUT CIRCUIT IMPEDANCE: 50 ohms.

RANGE: 0 to 800 W (peak power).

POWER REQUIREMENTS: 115 v, 400 cps.

MANUFACTURER'S OR CONTRACTOR'S DATA

Radio Receptor Co; Brooklyn, New York
Contract W-28-004-SC-164.

TUBE AND/OR CRYSTAL COMPLEMENT

No Electron Tubes.

REFERENCE DATA AND LITERATURE

TM-11-487H: Technical Manual for Directory of Signal Corps Equipments, Test Equipment.

TYPE CLASSIFICATION
DESIGN COGNIZANCE TASSA
PROCUREMENT COGNIZANCE
STOCK NO.
R.D.B. IDENT. NO.

EQUIPMENT SUPPLIED DATA

QUANTITY PER EQUIPT	NAME AND NOMENCLATURE	OVERALL DIMENSIONS (inches)	WEIGHT (lbs.)
1	Radio Test Set TS-159/TPX	6-7/8 x 10 x 14	15-1/2

TEST SET

TS-182/UP

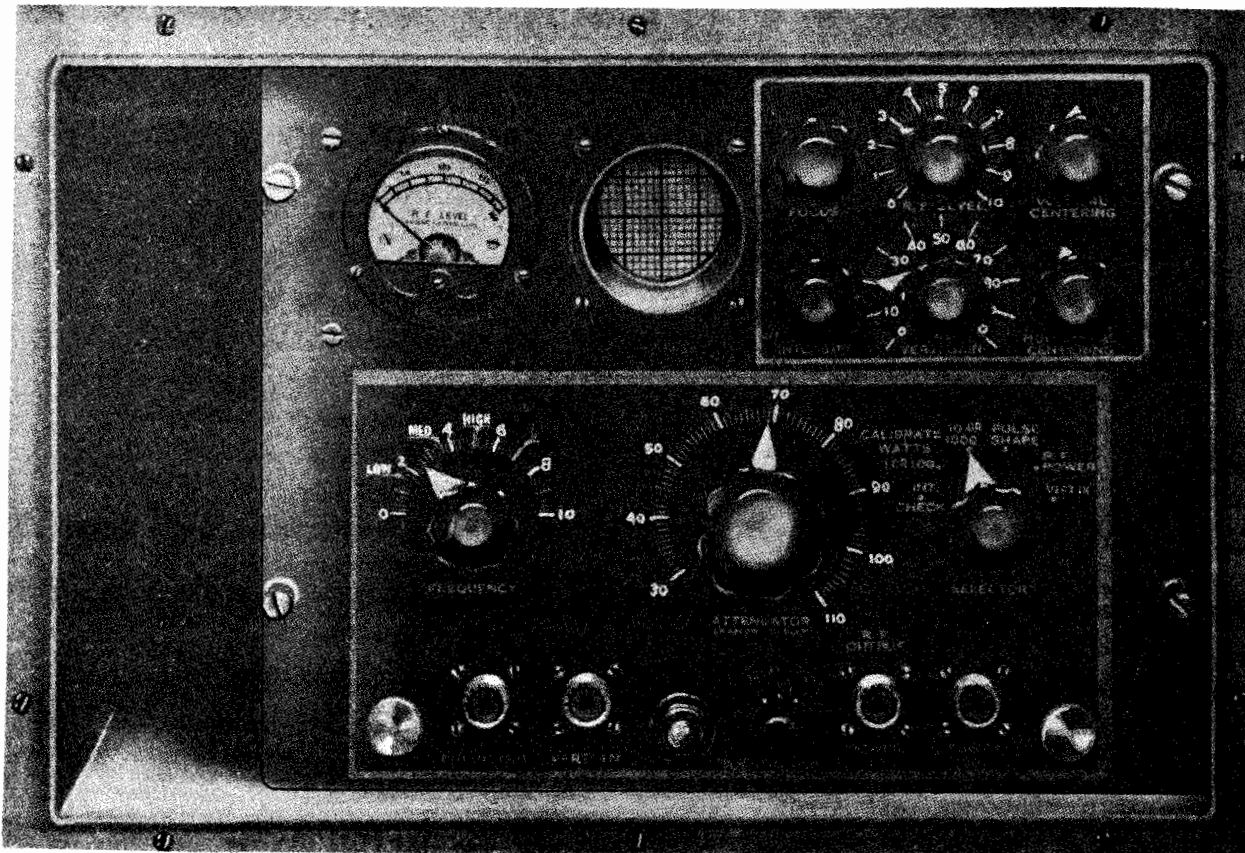

Test Set TS-182/UP

FUNCTIONAL DESCRIPTION

The TS-182/UP is used in checking the sensitivity of receivers or the power output of transmitters that receive and transmit pulse-modulated signals. The built-in oscilloscope shows pulse shapes of short rf and video pulses. The equipment consists of a signal generator, power meter, and synchroscope.

No field changes in effect at time of preparation (21 April 1958).

ELECTRICAL AND MECHANICAL CHARACTERISTICS

SIGNAL GENERATOR

FREQUENCY RANGE: 150 to 240 mc.
POWER RANGE: 30 to 110 db below 1 v.
IMPEDANCE: 50 ohms.
PULSE DELAY: 20 usec.
ACCURACY: 35%.

OSCILLOSCOPE

UNCLASSIFIED

FREQUENCY RESPONSE: 50 to 500,000 cycle.
IMPEDANCE: 75 ohms.
SWEEP DURATION: 200 usec.
SWEEP REPETITION RATE: 300 pps.
SYNCHRONIZING PULSE AMPLITUDE: +7.5 v (peak).
SYNCHRONIZING PULSE DELAY: 0 to 20 usec.

POWER MEASUREMENTS

POWER RANGE: 3,000 W.
IMPEDANCE: 50 ohms.
ACCURACY: $\pm 35\%$.

SENSITIVITY MEASUREMENTS

POWER RANGE: 30 to 110 db below 1 v.
RECEIVER VIDEO OUTPUT: 1 v (min).
ACCURACY: ± 2 db.

POWER REQUIREMENTS: 75 W, 115 v $\pm 5\%$, 50 to 1,200 cy.

MANUFACTURER'S OR CONTRACTOR'S DATA

Approximate Cost: \$720.00 with equipment spares.

April 1958

Test-Combination and Group

TS-182/UP**TEST SET****TUBE AND/OR CRYSTAL COMPLEMENT**

(1) 2AP1	(1) 6J5
(1) 5R4GY	(3) 6SN7
(1) 6AC7	(1) 6X5GT
(1) 6AG7	(1) 955
(1) 6AL5	

Total Tubes: (11)

No Crystals used.

REFERENCE DATA AND LITERATURE

AN08-35TS182-2: Handbook of Maintenance Instructions for Test Set TS-182/UP.

TYPE CLASSIFICATION**DESIGN COGNIZANCE** BUSHIPS**PROCUREMENT COGNIZANCE** NAVY SPEC RE-9525**STOCK NO.****R.D.B. IDENT. NO.****SHIPPING DATA**

NUMBER OF BOXES	CONTENTS AND IDENTIFICATION	VOLUME (Cu.Ft.)	OVERALL DIMENSIONS (inches)	WEIGHT PACKED (lbs.)
1	Test Set		23-1/2 x 23-1/2 x 29	118

EQUIPMENT SUPPLIED DATA

QUANTITY PER EQUIPT	NAME AND NOMENCLATURE	OVERALL DIMENSIONS (inches)	WEIGHT (lbs.)
1	Test Set TS-182/UP including:	9-1/4 x 12 x 16	43
1	Tuning Unit TN-79/UP	5 x 5-1/4 x 9-3/4	5.75
2	Connecting Cable	48 lg	
1	Test Cable	48 lg	
2	Adapter UG-197/U		
2	Adapter	Amphenol 83-14	
2	Adapter		
1	Cord, AC Line	83-1H	
1	Transit Case CY-278/UP	11 x 16 x 17	15
1	100:1 Power Adapter CN-46/U	1-1/4 x 1-1/4 x 4	

TEST SET

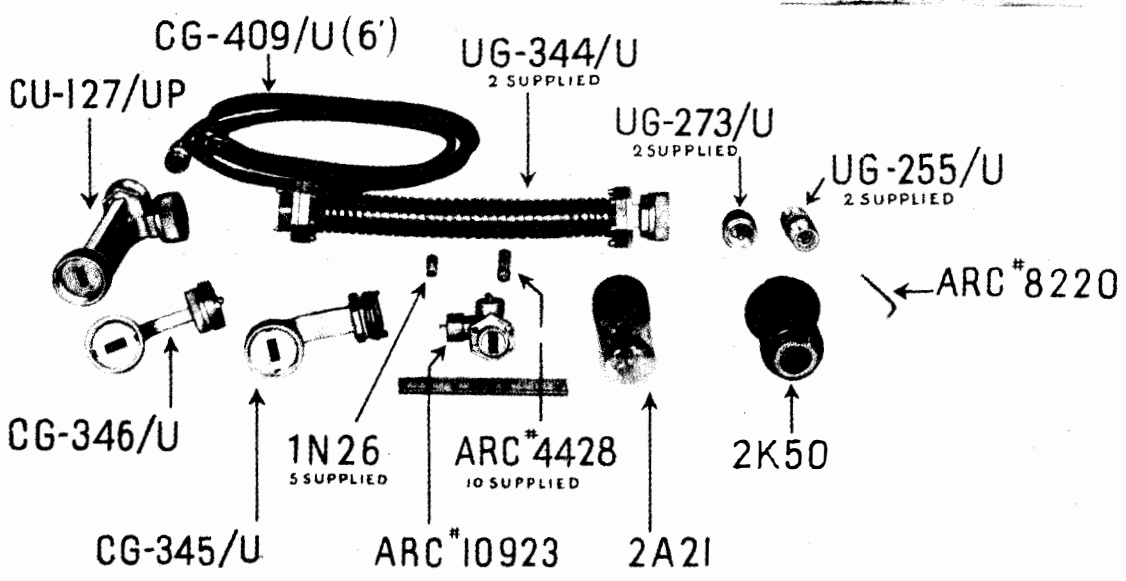
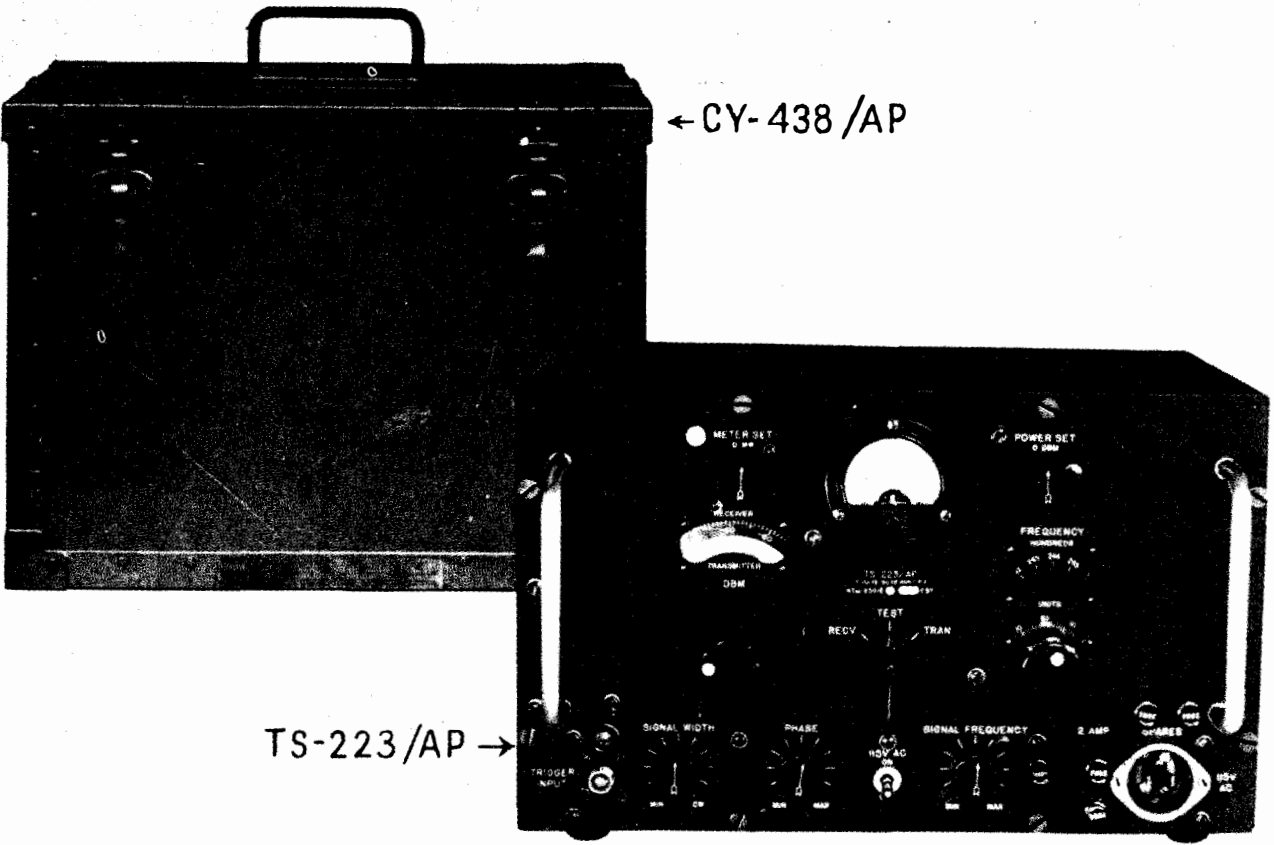

Test Set TS-223/AP

FUNCTIONAL DESCRIPTION

The TS-223/AP is used to make laboratory or field tests on radar equipment in the 23,500 to 24,500 mc frequency range. It checks receiver sensitivity, power output and band width, measures transmitter power output and frequency, checks radar receiver recovery time, tests type 2K50 oscillator tubes, and measures power when used with Radio Frequency Power Indicator TS-229/U.

No field changes in effect at time of preparation (22 August 1956).

ELECTRICAL AND MECHANICAL CHARACTERISTICS

METER RANGES

RECEIVER SENSITIVITY: -37 to -90 dbm.
 TRANSMITTER OUTPUT: +10 to +30 dbm.
 FREQUENCY: 23,500 to 24,500 mc.

SIGNAL GENERATOR

FREQUENCY: 23,500 to 24,500 mc.
 EMISSION: FM.

TUBE TEST: Tests 2K50 oscillator tubes in a substitution set up.

OPERATING POWER: 105 to 125 v, 50 to 1600 cps, single ph.

MANUFACTURER'S OR CONTRACTOR'S DATA

Aircraft Radio Corp., Boonton, N.J.
 Contract NXss-85016.

TUBE AND/OR CRYSTAL COMPLEMENT

(1) 2A21	(1) 2K50
(1) OD3/VR-150	(1) 5R4GY
(1) SH7	(2) 6SL7GT
(1) 6Y6	

Total Tubes: (8)

REFERENCE DATA AND LITERATURE

AN16-35TS223-3: Technical Manual for Test Set TS-223/AP.

TYPE CLASSIFICATION
 DESIGN COGNIZANCE BUAER
 PROCUREMENT COGNIZANCE
 STOCK NO.
 R.D.B. IDENT. NO.

EQUIPMENT SUPPLIED DATA

QUANTITY PER EQUIPT	NAME AND NOMENCLATURE	OVERALL DIMENSIONS (inches)	WEIGHT (lbs.)
1	Test Set TS-223/AP	9-3/8 X 10-1/4 X 15	24.2
1	Carrying Case CY-438/AP	10-1/4 X 13 X 18-3/4	13.9
1	Set Operating Spares consisting of:		0.6
1	RF Oscillator Tube 2K50		
1	Ballast Tube 2A21		
2	Indicator Lamps Mazda 47		
10	Fuses 2A		
5	Crystal Det. 1N26		
1	Thermistor Assy		
1	Bristo Wrench		
1	Set Accessories consisting of:		2.8
2	Waveguides UG-344/U		
1	Cable CX-337/U	72 lg	
2	Adapters UG-255/U		
2	Adapters UG-273/U		
1	Cable CG-409/U	72 lg	
1	Coupler CU-127/UP		
1	Waveguide CG-345/U		
1	Waveguide CG-346/U		
1	Technical Manual		

April 1959

Test-Combination and Group

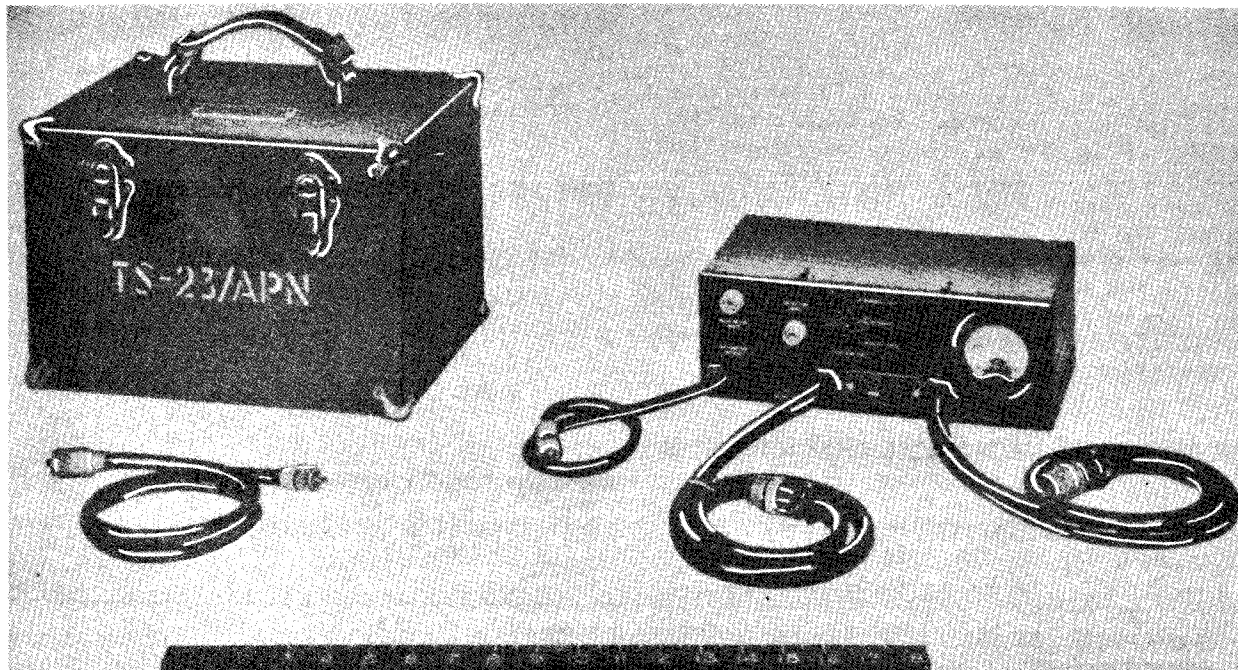
TEST SET**TS-23/APN***Test Set TS-23/APN***FUNCTIONAL DESCRIPTION**

Test Set TS-23/APN is a portable equipment used in measuring transmitter frequency, in checking transmitter power output, in supplying detected transmitter pulses to the indicator of the set under test, and in measuring the B+ voltage of the set under test. Application is in field and depot testing.

No field changes in effect at time of preparation (25 March 1959).

ELECTRICAL AND MECHANICAL CHARACTERISTICS

POWER REQUIREMENTS: 200 W, 115 v $\pm 10\%$, 10 ma, 400 to 1,000 cy, 1 ph.

FREQUENCY

INPUT: 440 mc.

OUTPUT: Video.

TYPE OF RECEPTION: Pulse.

IMPEDANCE

INPUT: 50 ohms.

OUTPUT: 75 ohms.

ACCURACY: ± 0.3 mc.

MANUFACTURER'S OR CONTRACTOR'S DATA

Electronic Corp of America, NY., NY.

TUBE AND/OR CRYSTAL COMPLEMENT

(1) 9004

Total Tubes: (1)

No Crystals used.

REFERENCE DATA AND LITERATURE

NAVSHIPS 93003, Vol 1: Electronic Test Equipment.

Nomenclature Card for TEST SET TS-23/APN.

TYPE CLASSIFICATION

DESIGN COGNIZANCE USAF

PROCUREMENT COGNIZANCE SPEC MIL-T-4310 (USAF);

STOCK NO.

USAF DWG 51C13952

R.D.B. IDENT. NO. 10.1.1

April 1959

Test-Combination and Group

TS-23/APN**TEST SET****EQUIPMENT SUPPLIED DATA**

QUANTITY PER EQUIPT	NAME AND NOMENCLATURE	OVERALL DIMENSIONS (inches)	WEIGHT (lbs.)
1	Test Set TS-23/APN Including:	4 X 6 X 11	7
1	Cord CG-107/U	36 lg	0.38
1	Case	8 X 8-1/2 X 12	8
1	Allen Wrench		

FREQUENCY - POWER METER

TS-230/AP

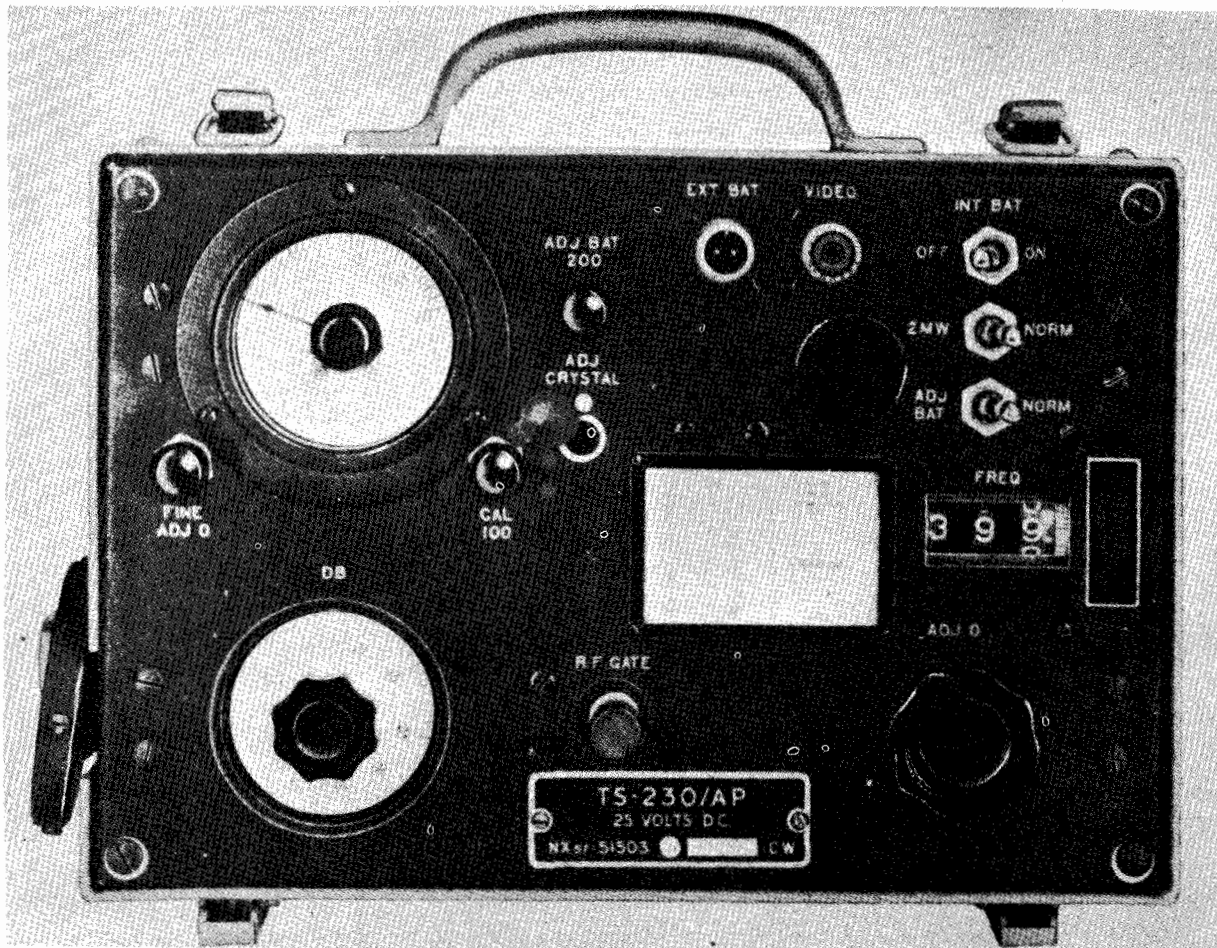

Frequency-Power Meter TS-230/AP

FUNCTIONAL DESCRIPTION

Frequency-Power Meter TS-230/AP is a portable test set used in measuring frequency and power of unmodulated and pulsed signals. It permits the detection of small percentages of rf power so that wave forms of pulsed signals can be displayed on an oscilloscope.

No field changes in effect a time of preparation (30 November 1959).

ELECTRICAL AND MECHANICAL CHARACTERISTICS

FREQUENCY RANGE: 8500 to 9600 mc.
 FREQUENCY MEASURING ACCURACY: ± 3.0 mc (absolute), ± 0.5 mc (relative).
 TYPE OF RECEPTION: CW, pulse.

AMBIENT TEMPERATURE: -40° to $+50^{\circ}$ C (-40° to $+122^{\circ}$ F).

POWER MEASURING RANGE: 0.1 to 1,000 mw (-10 to $+30$ dbm).

POWER MEASURING ACCURACY

0.1 TO 1.0 MW: ± 1 db.

1.0 TO 1000 MW: ± 1.5 db.

INPUT POWER

MAXIMUM: 200 W peak or 2 W avg.

MINIMUM: 0.1 mw avg.

POWER SOURCE

INTERNAL: 6 v DC, 0.03 amp, 0.2 W.

-EXTERNAL: 24 to 30 v DC, 0.19 amp, 5 W.

MANUFACTURER'S OR CONTRACTOR'S DATA

Western Electric Co., Inc., New York, N. Y.

Test-Combination and Group

TS-230/AP

FREQUENCY - POWER METER

Contract NXsr-51503, dated 5 May 1945.
Contract NXss-32196, dated 5 May 1945.
Contract NOrd-3644, dated 5 May 1945.
Contract NObsr-43067, dated 9 November
1948.

REFERENCE DATA AND LITERATURE

SHIPS 372: Technical Manual for FREQUENCY-
POWER METER TS-230/AP.

TUBE AND/OR CRYSTAL COMPLEMENT

No Electron Tubes used.

(1) 1N23

Total Crystals: (1)

TYPE CLASSIFICATION (NAVY) SUB STD
DESIGN COGNIZANCE USN, BUSHIPS
PROCUREMENT COGNIZANCE SPEC: RE-13A787
STOCK NO.
R.D.B. IDENT. NO. 10.1.1

SHIPPING DATA

NUMBER OF BOXES	CONTENTS AND IDENTIFICATION	VOLUME (Cu.Ft.)	OVERALL DIMENSIONS (inches)	WEIGHT PACKED (lbs.)
1	Frequency-Power Meter TS-230/AP	1.9	11 X 15 X 17	35

EQUIPMENT SUPPLIED DATA

QUANTITY PER EQUIPT	NAME AND NOMENCLATURE	OVERALL DIMENSIONS (inches)	WEIGHT (lbs.)
1	Frequency-Power Meter TS-230/AP	6 X 10 X 12	10.5

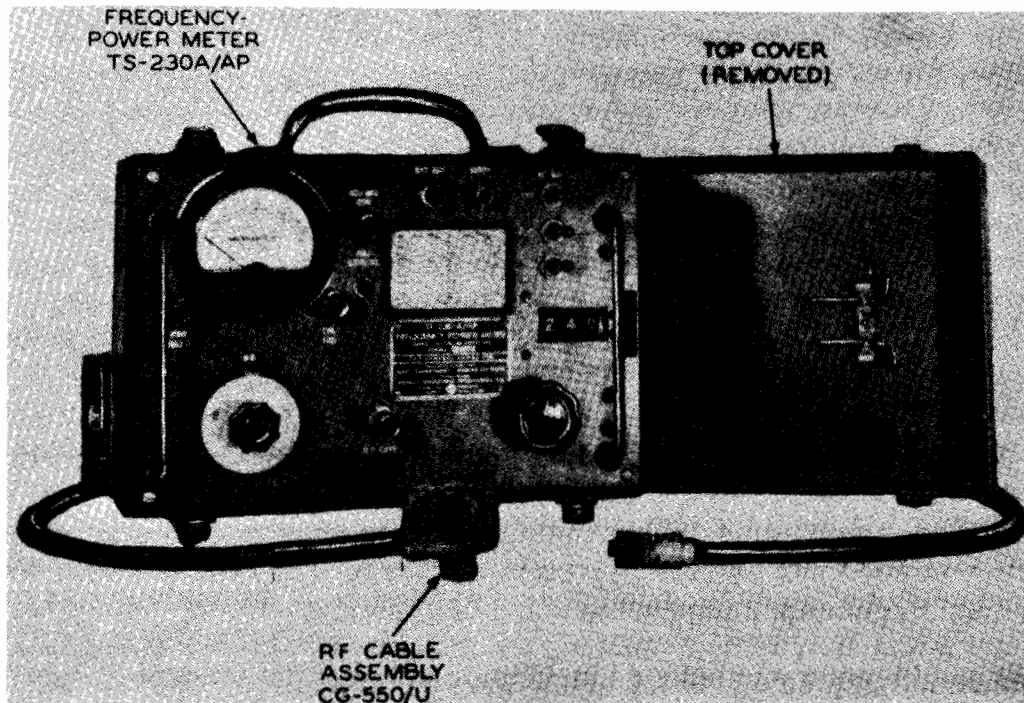
FREQUENCY - POWER METER**TS-230A/AP***Frequency-Power Meter TS-230A/AP***FUNCTIONAL DESCRIPTION**

Frequency-Power Meter TS-230A/AP is a portable test set used in measuring frequency and power of unmodulated and pulsed signals. It permits the detection of small percentages of rf power so that wave forms of pulsed signals can be displayed on an oscilloscope.

No field changes in effect at time of preparation (30 November 1959).

EQUIPMENT REQUIRED BUT NOT SUPPLIED

Battery: (4) BA-30; (1) Oscilloscope TS-34/AP series or TS-239/AP series.

ELECTRICAL AND MECHANICAL CHARACTERISTICS

FREQUENCY RANGE: 8,500 to 9,600 mc.
 FREQUENCY MEASURING ACCURACY: ± 4.0 mc (absolute), ± 0.5 mc (relative).
 TYPE OF RECEPTION: CW, pulse.
 AMBIENT TEMPERATURE: -40° to $+55^{\circ}$ C (-40° to $+131^{\circ}$ F).
 POWER MEASURING RANGE: 0.1 to 1,000 mw (-10

to $+30$ dbm).

POWER MEASURING ACCURACY

0.1 TO 1.0 MW: ± 1 db.
 1.0 TO 1000 MW: ± 1.5 db.

INPUT POWER

MAXIMUM: 200 W peak, or 2 W avg.
 MINIMUM: 0.1 mw avg.

POWER SOURCE

INTERNAL: 6 v DC.
 EXTERNAL: 24 to 30 v DC, 0.19 amp, 5 W.

MANUFACTURER'S OR CONTRACTOR'S DATA

Midwest Engineering Development Co., Inc.,
 Kansas City, Missouri.
 Contract Nobsr-39303, 19 June 1947.
 Western Electric Co., New York, New York
 Contract Nobsr-43067, 9 November 1948.

TUBE AND/OR CRYSTAL COMPLEMENT

No. Electron Tubes used.

(1) 1N23A
 Total Tubes: (1)

Test-Combination and Group

February 1960

TS-230A/AP**FREQUENCY - POWER METER****REFERENCE DATA AND LITERATURE**

NAVSHIPS 91105: Technical Manual for FRE-
QUENCY-POWER METER TS-230A/AP.

TYPE CLASSIFICATION (NAVY)
DESIGN COGNIZANCE USN, BUSHIPS
PROCUREMENT COGNIZANCE SPEC: CS-677(NAVY)
STOCK NO.
R.D.B. IDENT. NO. 10.1.1

SHIPPING DATA

NUMBER OF BOXES	CONTENTS AND IDENTIFICATION	VOLUME (Cu.Ft.)	OVERALL DIMENSIONS (inches)	WEIGHT PACKED (lbs.)
1	Frequency-Power Meter TS-230A/AP	2.24	11.0 X 16.0 X 22.0	28.0

EQUIPMENT SUPPLIED DATA

QUANTITY PER EQUIPT	NAME AND NOMENCLATURE	OVERALL DIMENSIONS (inches)	WEIGHT (lbs.)
1	Frequency-Power Meter TS-230A/AP	6.0 X 8.0 X 12.0	10.62
1	R.F. Cable Assembly CG-550/U	1.38 X 1.88 X 65.0	1.0
2	Technical Manual NAVSHIPS 91105	0.75 X 9.0 X 11.5	1.25
1	Set Equipment Spares	5.0 X 6.0 X 12.0	5.06
4	Batteries NT-19031	1.12 X 1.12 X 9.5	0.75

FREQUENCY - POWER METER

TS-230B/AP

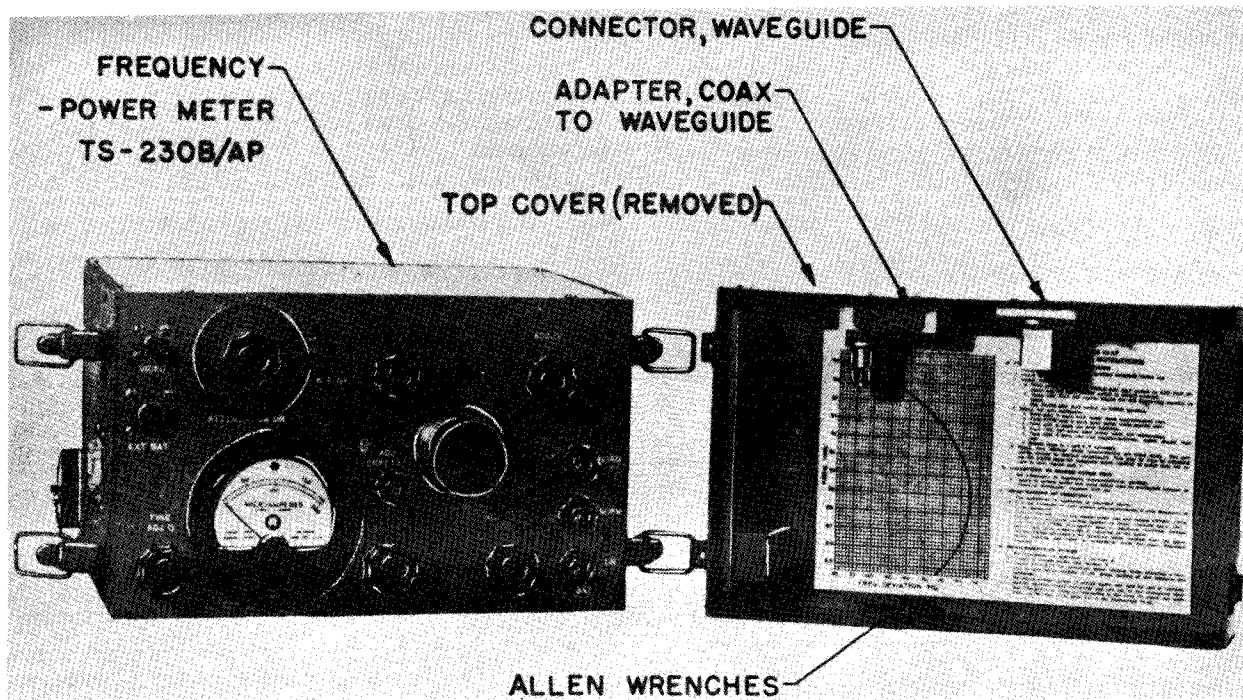

Frequency -Power Meter TS-230B/AP

FUNCTIONAL DESCRIPTION

Frequency-Power Meter TS-230B/AP is a portable test set used in measuring frequency and power of unmodulated and pulsed signals. It permits the detection of small percentages of rf power so that wave forms of pulsed signals can be displayed on an oscilloscope.

No field changes in effect at time of preparation (30 November 1959).

EQUIPMENT REQUIRED BUT NOT SUPPLIED

Battery: (4) BA-30; (1) Oscilloscope TS-34/AP series, TS-239/UP series, or AN/USM-24.

ELECTRICAL AND MECHANICAL CHARACTERISTICS

FREQUENCY RANGE: 8,500 to 9,600 mc.

FREQUENCY MEASURING ACCURACY: ± 4.0 mc (absolute), ± 0.5 mc (relative).

TYPE OF RECEPTION: CW, pulse.

AMBIENT TEMPERATURE: -40° to $+55^{\circ}$ C (-40° to $+131^{\circ}$ F).

POWER MEASURING RANGE: 0.1 to 1,000 mw (-10 to $+30$ dbm).

POWER MEASURING ACCURACY

1.1 TO 1.0 MW: ± 1.0 db.

1.0 TO 1000 MW: ± 1.5 db.

INPUT POWER

MAXIMUM: 200 W peak or 2 W avg.

MINIMUM: 0.1 mw avg.

POWER SOURCE

INTERNAL: 6 v DC.

EXTERNAL: 24 to 30 v DC, 0.19 amp, 5 W.

MANUFACTURER'S OR CONTRACTOR'S DATA

Electro Impulse Laboratory, Red Bank, N.J.
Contract NObsr-49218, dated 20 June 1950.

Contract NObsr-52140, dated 20 December 1950.

Test-Combination and Group

TS-230B/AP

FREQUENCY - POWER METER

TUBE AND/OR CRYSTAL COMPLEMENT

No Electron Tubes used.

(1) 1N23A

Total Crystals: (1)

REFERENCE DATA AND LITERATURE

NAVSHIPS 91714: Technical Manual for FRE-
QUENCY-POWER METER TS-230B/AP.

TYPE CLASSIFICATION (NAVY)
DESIGN COGNIZANCE USN, BUSHIPS
PROCUREMENT COGNIZANCE SPEC: SHIPS-M-89
STOCK NO.
R.D.B. IDENT. NO. 10.1.1

SHIPPING DATA

NUMBER OF BOXES	CONTENTS AND IDENTIFICATION	VOLUME (Cu.Ft.)	OVERALL DIMENSIONS (inches)	WEIGHT PACKED (lbs.)
1	Frequency-Power Meter TS-230B/AP	1.0	7.5 X 12.25 X 14.25	20.0

EQUIPMENT SUPPLIED DATA

QUANTITY PER EQUIPT	NAME AND NOMENCLATURE	OVERALL DIMENSIONS (inches)	WEIGHT (lbs.)
1	Frequency-Power Meter TS-230B/AP	6.5 X 11.25 X 13.25	17.00
2	Technical Manual NAVSHIPS 91714	0.75 X 9.0 X 11.5	1.25

FREQUENCY - POWER METER

TS-230C/AP

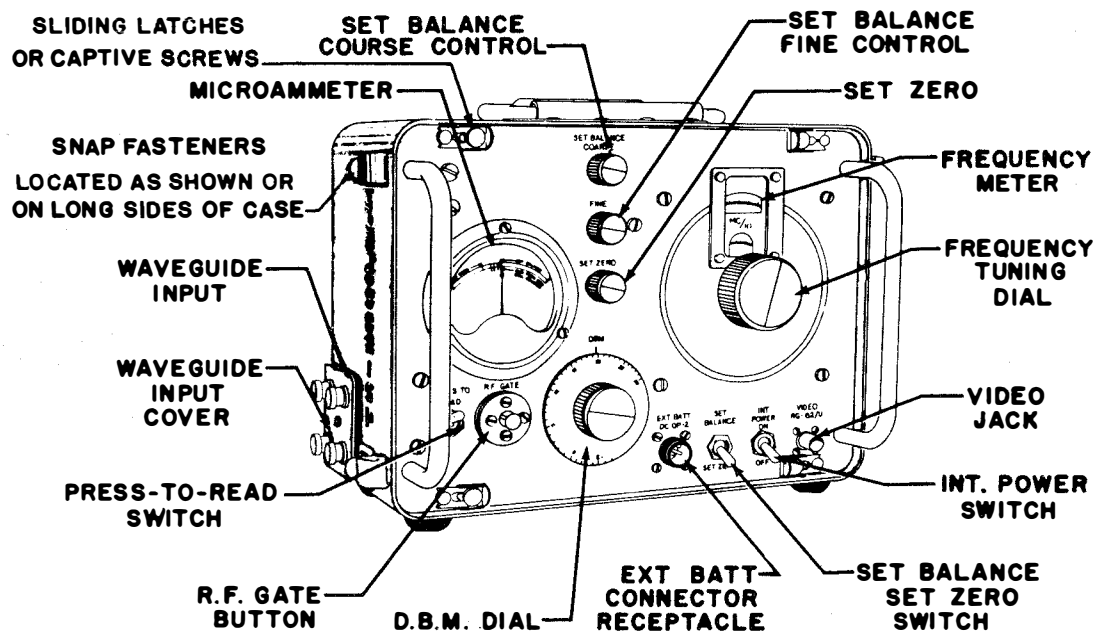
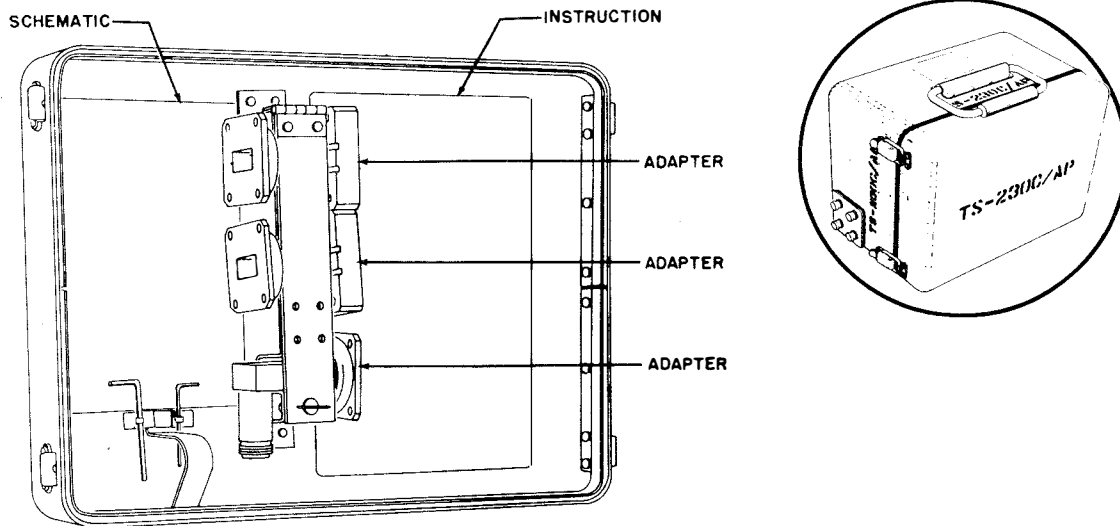

Frequency-Power Meter TS-230C/AP

February 1960

Test-Combination And Group

TS-230C/AP**FREQUENCY - POWER METER****FUNCTIONAL DESCRIPTION**

Frequency-Power Meter TS-230C/AP is a portable test set used in measuring frequency and power of unmodulated and pulsed signals. It permits the detection of small percentages of rf power so that wave forms of pulsed signals can be displayed on an oscilloscope.

No field changes in effect at time of preparation (30 November 1959).

EQUIPMENT REQUIRED BUT NOT SUPPLIED

Battery: (4) BA-30; (1) Oscilloscope TS-34/AP, or TS-239/UP series.

ELECTRICAL AND MECHANICAL CHARACTERISTICS

FREQUENCY RANGE: 8,500 to 9,600 mc.

FREQUENCY MEASURING ACCURACY: ± 4.0 mc (absolute), ± 0.5 mc (relative).

TYPE OF RECEPTION: CW, pulse.

AMBIENT TEMPERATURE: -40° to $+55^{\circ}$ C (-40° to 131° F).

POWER MEASURING RANGE: 0.1 to 1,000 mw (-10 to $+30$ dbm).

POWER MEASURING ACCURACY

0.1 TO 1.0 MW: ± 2 db.

1.0 TO 1000 MW: ± 2.5 db.

INPUT POWER

MAXIMUM: 1 W avg.

MINIMUM: 0.1 mw avg.

POWER SOURCE

INTERNAL: 6 v DC.

EXTERNAL: 24 to 30 v DC, 0.25 amp 7.5.W.

MANUFACTURER'S OR CONTRACTOR'S DATA

Hycon Mfg. Co., Pasadena, California.

Contract NObsr-52598, dated 15 June 1951.

Kings Electronics Co., Inc, Tukahoe, N. Y.

Contract NObsr-64254, dated 28 June 1954.

Electro Impulse Laboratory, Red Bank, New Jersey.

Contract NObsr-71746.

Contract NObsr-71876.

TUBE AND/OR CRYSTAL COMPLEMENT

No Electron Tubes used.

(1) 1N23A

Total Crystals: (1)

REFERENCE DATA AND LITERATURE

NAVSHIPS 91669: Technical Manual for FREQUENCY-POWER METER TS-230C/AP.

TYPE CLASSIFICATION (NAVY) STD

DESIGN COGNIZANCE USN, BUSHIPS

PROCUREMENT COGNIZANCE SPEC:

STOCK NO.

SHIPS-F-2698

R.D.B. IDENT. NO. 10.1.1

SHIPPING DATA

NUMBER OF BOXES	CONTENTS AND IDENTIFICATION	VOLUME (Cu.Ft.)	OVERALL DIMENSIONS (inches)	WEIGHT PACKED (lbs.)
1	Frequency-Power Meter TS-230C/AP	2.94	15.5 X 16.5 X 20.5	22.0

EQUIPMENT SUPPLIED DATA

QUANTITY PER EQUIP	NAME AND NOMENCLATURE	OVERALL DIMENSIONS (inches)	WEIGHT (lbs.)
1	Frequency-Power Meter TS-230C/AP including:	8 X 9-3/4 X 12-1/2	16.09
1	Adapter, waveguide	1-7/8 X 1-7/8 X 1-15/16	0.69
1	Adapter, Waveguide	1-5/8 X 2-1/8 X 2-11/32	0.78
1	Adapter, Waveguide	1-7/8 X 1-7/8 X 1-29/32	0.69
1	Wrench, Allen No. 4		
1	Wrench, Allen No. 8		
2	Technical Manual NAVSHIPS 91669	0.25 X 9.0 X 11.5	1.10

4.10 TS-230C/AP: 2

UNCLASSIFIED

5 April 1962

Cog Service: USN FSN: 6625-643-3124

FREQUENCY-POWER METER TS-230D/AP
Functional Class: 10.1.1

USA

USN

USAF

TYPE CLASS:

Std

MANUFACTURER'S NAME/CODE NUMBER: Electro Impulse Laboratory.



Frequency-Power Meter TS-230D/AP

FUNCTIONAL DESCRIPTION:

Frequency-Power Meter TS-230D/AP is a portable test set designed to measure the frequency and power of unmodulated and pulsed signals. It permits the detection of small percentages of rf power so that wave forms of pulsed signals can be displayed on an oscilloscope.

No field changes in effect at time of preparation (5 January 1962).

TECHNICAL CHARACTERISTICS:

FREQUENCY RANGE: 8,500 to 9,700 mc.

FREQUENCY MEASURING ACCURACY: Porm 4.0 mc (absolute), porm 0.5 mc (on frequency difference).

TEMPERATURE COEFFICIENT OF CALIBRATION: 0.05 mc/degree C.

AMBIENT TEMPERATURE: M40 to P55 deg C (M40 to P131 deg F).

POWER MEASURING RANGE: 0.1 to 1,000 mw.

POWER MEASURING ACCURACY: Porm 1.0 db (1.1 to 1.0 mw), porm 1.5 db (1.0 to 1,000 mw).

TS-230D/AP FREQUENCY-POWER METER

MAXIMUM INPUT POWER: 200 W peak or 2 W avg.

MINIMUM INPUT POWER: 0.1 mw avg.

POWER REQUIREMENTS

INTERNAL: 6 v dc.

EXTERNAL: 24 to 30 v dc, 0.19 amps, 5 W.

RELATION TO OTHER EQUIPMENT:

This equipment is basically identical and supersedes Frequency Meter TS-33/AP.

EQUIPMENT REQUIRED BUT NOT SUPPLIED:

(1) Oscilloscope AN/USM-24, TS-34/AP, or TS-239/UP; (4) Battery NT-19031 or BA-30.

MAJOR COMPONENTS

QTY	ITEM	STOCK NUMBERS	DIMENSIONS (INCHES)	WEIGHT (LBS)
1	Frequency-Power Meter TS-230D/AP includes:		6.5 x 11.25 x 13.25	17.00
2	Technical Manual NAVSHIPS 92124		0.75 x 9.0 x 11.5	1.25

REFERENCE DATA AND LITERATURE:

NAVSHIPS 92124: Technical Manual for Frequency Power Meter TS-230D/AP.

AN16-35TS230-5: Technical Manual for Frequency Power Meter TS-230D/AP.

TUBE, CRYSTAL AND/OR SEMI-CONDUCTOR DATA:

TUBES: None used.

CRYSTALS: None used.

SEMI-CONDUCTORS: (1) 1N23A

SHIPPING DATA

PKGS	VOLUME (CU FT)	WEIGHT (LBS)
1	1.0	20.0

PROCUREMENT DATA

PROCURING SERVICE: USN

DESIGN COG: USN, BuShips

SPEC &/OR DWG: MIL-M-15453A (SHIPS)

4.10 TS-230D/AP: 2

FREQUENCY-POWER METER TS-230D/AP

CONTRACTOR	LOCATION	CONTRACT OR ORDER NO.	APPROX. UNIT COST
Electro Impulse Laboratory	Red Bank, N. J.	N0bsr-57389, 12 May 1952	\$799.38

18 May 1962

Cog Service: USN FSN: 6625-715-3998

FREQUENCY-POWER METER TS-230E/AP
Functional Class: 10.1.1

USA

USN

USAF

TYPE CLASS:

Std

MANUFACTURER'S NAME/CODE NUMBER: Specialty Electronics Development Corp., (99872).

(No Illustration Available)

FUNCTIONAL DESCRIPTION:

Frequency-Power Meter TS-230E/AP is a portable test set designed to measure the frequency and power of unmodulated and pulsed signals. It permits the detection of small percentages of rf power so that wave forms of pulsed signals can be displayed on an oscilloscope.

No field changes in effect at time of preparation (5 January 1962).

TECHNICAL CHARACTERISTICS:

FREQUENCY RANGE: 8,500 to 9,700 mc.

FREQUENCY MEASURING ACCURACY: Porm 4.0 mc (absolute), porm 0.5 mc (on frequency difference).

AMBIENT TEMPERATURE: M40 to P55 deg C (M40 to 131 deg F).

POWER MEASURING RANGE: 0.1 to 1,000 mw.

MINIMUM INPUT POWER: 0.1 mw avg.

POWER REQUIREMENTS

INTERNAL: 6 v dc.

EXTERNAL: 24 to 30 v dc.

RELATION TO OTHER EQUIPMENT: None.

EQUIPMENT REQUIRED BUT NOT SUPPLIED:

(1) Oscilloscope AN/USM-24, TS-34/AP, or TS-239/UP; (4) Battery NT-19031 or BA-30.

MAJOR COMPONENTS

QTY	ITEM	STOCK NUMBERS	DIMENSIONS (INCHES)	WEIGHT (LBS)
1	Frequency-Power Meter TS-230E/AP		6-1/2 x 11-1/4 x 13-1/4	17

REFERENCE DATA AND LITERATURE: None.

TUBE, CRYSTAL AND/OR SEMI-CONDUCTOR DATA:

TUBES: None used.

CRYSTALS: None used.

SEMI-CONDUCTORS: (1) 1N23C

December 1956

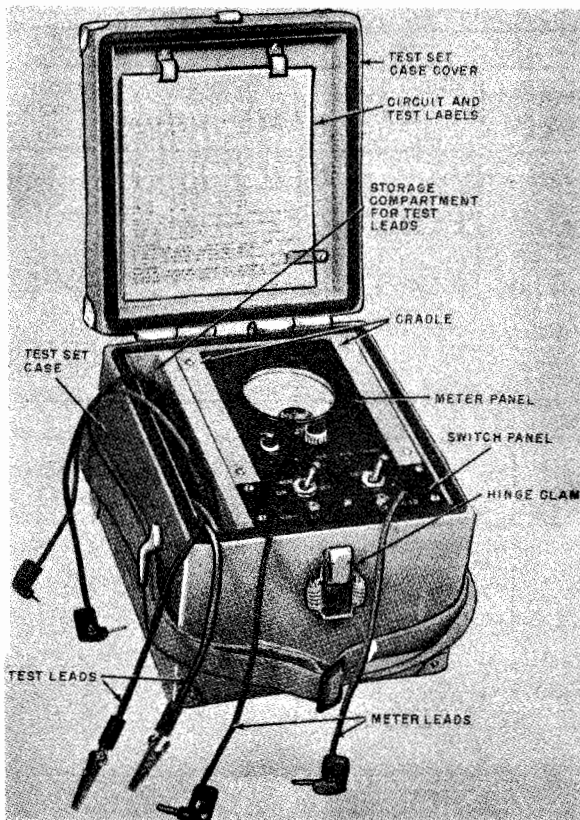
TEST SET**TS-26/TSM,
26A/TSM, 26B/TSM**

Test Set TS-26/TSM, 26A/TSM, 26B/TSM

FUNCTIONAL DESCRIPTION

The TS-26/TSM, TS-26A/TSM, or TS-26B/TSM is a portable test set for use by pole linemen and field wiremen in identifying and locating grounds, crosses, shorts, and opens on a telephone line. It can also measure insulation and conductor resistance and direct current voltages.

The differences between models is the TS-26/TSM and TS-26B/TSM is that the meter zero is located on a metal rim at bottom of meter. On the TS-26A/TSM the meter zero adjustment is located on the glass window of meter.

No field changes in effect at time of preparation (9 August 1956).

RELATION TO OTHER EQUIPMENT

Equipment Required but not Supplied: (1) Ground Rod MX-148/G, (1) Clamp TM-106, (1)

Battery BA-31, (1) Battery BA-59.

ELECTRICAL AND MECHANICAL CHARACTERISTICS

VOLTAGE RANGES: 0 to 3 v DC, 0 to 30 v DC, 0 to 300 v DC, 0 to 600 v DC.

RESISTANCE RANGES: 0 to 1000 ohms, 0 to 10,000 ohms, 0 to 100,000 ohms, 0 to 1 meg, 0 to 10 meg.

INTERNAL RESISTANCE OF METER

TS-26/TSM: 2000 ohms.

TS-26A/TSM and TS-26B/TSM: 760 ohms.

BATTERIES REQUIRED: One 4-1/2 v and one (1) 45 v.

MANUFACTURER'S OR CONTRACTOR'S DATA

Weston Electrical Instrument Co., Newark, N. J.

Model No. 564 Type 3C.

TUBE AND/OR CRYSTAL COMPLEMENT

No Electron Tubes.

REFERENCE DATA AND LITERATURE

TM11-2017, TO33A1-12-38-1: Dept of Army and Air Force Technical Manual for Test Sets- TS-26/TSM, TS-26A/TSM, and TS-26B/TSM.

Sig 7 and 8 Organizational Maintenance Allowances and Field and Base Maintenance Stockage Guide for Test Set TS-26/TSM.

TYPE CLASSIFICATION
DESIGN COGNIZANCE TASSA
PROCUREMENT COGNIZANCE
STOCK NO.
R.D.B. IDENT. NO.

**TS-26/TSM,
26A/TSM,26B/TSM**
TEST SET

December 1956

SHIPPING DATA

NUMBER OF BOXES	CONTENTS AND IDENTIFICATION	VOLUME (Cu.Ft.)	OVERALL DIMENSIONS (inches)	WEIGHT PACKED (lbs.)
1	For Domestic Shipment Test Set - TS-26/TSM	0.424	8-3/8 X 9-1/4 X 9-1/2	9
1	For Export Shipment Test Set - TS-26/TSM	0.489	8-7/8 X 9-3/4 X 9-3/4	9-1/2

EQUIPMENT SUPPLIED DATA

QUANTITY PER EQUIPT	NAME AND NOMENCLATURE	OVERALL DIMENSIONS (inches)	WEIGHT (lbs.)
1	Test Unit - TS-26/TSM	7 X 7 X 8	7-3/4
1	Red Test Lead	48 1g	1/32
1	Black Test Lead	48 1g	1/32

February 1960

Test-Combination and Group

RADAR TEST SET**TS-295/UP***Radar Test Equipment Model TS-295/UP***FUNCTIONAL DESCRIPTION**

Radar Test Set TS-295/UP is a power and frequency measuring set used with an oscilloscope to permit the study of video characteristics of radar signals. It measured frequency by the method of minimum reaction at resonance, as well as CW or pulsed power and frequency by the maximum absorption method.

No field changes in effect at time of preparation (2 December 1959).

RELATION TO OTHER EQUIPMENT

This equipment is similar to Test Set

TS-3/AP.

EQUIPMENT REQUIRED BUT NOT SUPPLIED

Battery: (3) NT-19031

ELECTRICAL AND MECHANICAL CHARACTERISTICS

POWER REQUIREMENTS: 4.5 v DC.

FREQUENCY RANGE: 3,400 to 3,900 mc, ± 2 mc.

UNCLASSIFIED

4.10 TS-295/UP: 1

Test-Combination and Group

February 1960

RADAR TEST SET**TS-295/UP**POWER RANGE: 0.5 to 12.5 mw (-3 to +11 dbm),
±1 db.

IMPEDANCE: 50 ohms.

DC METER RANGE: 0 to 1.5 ma; 0 to 23 mw.

TEMPERATURE RANGE: -70° to +50° C.

REFERENCE DATA AND LITERATURESHIPS 311(A): Technical Manual for RADAR
TEST EQUIPMENT TS-295/UP**MANUFACTURER'S OR CONTRACTOR'S DATA**Western Electric Co., New York, New York.
Contract NXsr-66745, dated 16 June
1944.TYPE CLASSIFICATION Std
DESIGN COGNIZANCE USN, BUSHIPS
PROCUREMENT COGNIZANCE
STOCK NO.
R.D.B. IDENT. NO. 10.1.1**TUBE AND/OR CRYSTAL COMPLEMENT**

No Electron Tubes used.

(1) 1N21B

Total Crystals: (1)

SHIPPING DATA

NUMBER OF BOXES	CONTENTS AND IDENTIFICATION	VOLUME (Cu.Ft.)	OVERALL DIMENSIONS (inches)	WEIGHT PACKED (lbs.)
1	Radar Test Set TS-295/UP	2.1	14-3/8 X 14-5/8 X 16-7/8	16

EQUIPMENT SUPPLIED DATA

QUANTITY PER EQUIPT	NAME AND NOMENCLATURE	OVERALL DIMENSIONS (inches)	WEIGHT (lbs.)
1	Radar Test Set TS-295/UP including:	9-1/4 X 9-3/8 X 11-3/8	12.5
1	Connecting Cable CG-258/U		
1	Cable, Low Loss CG-257/U	85 lg	
1	Cable, Patch CG-256/U	6 lg	
1	Connecting Cable CG-358/U		

February 1960

FREQUENCY - POWER METER

TS-295A/UP

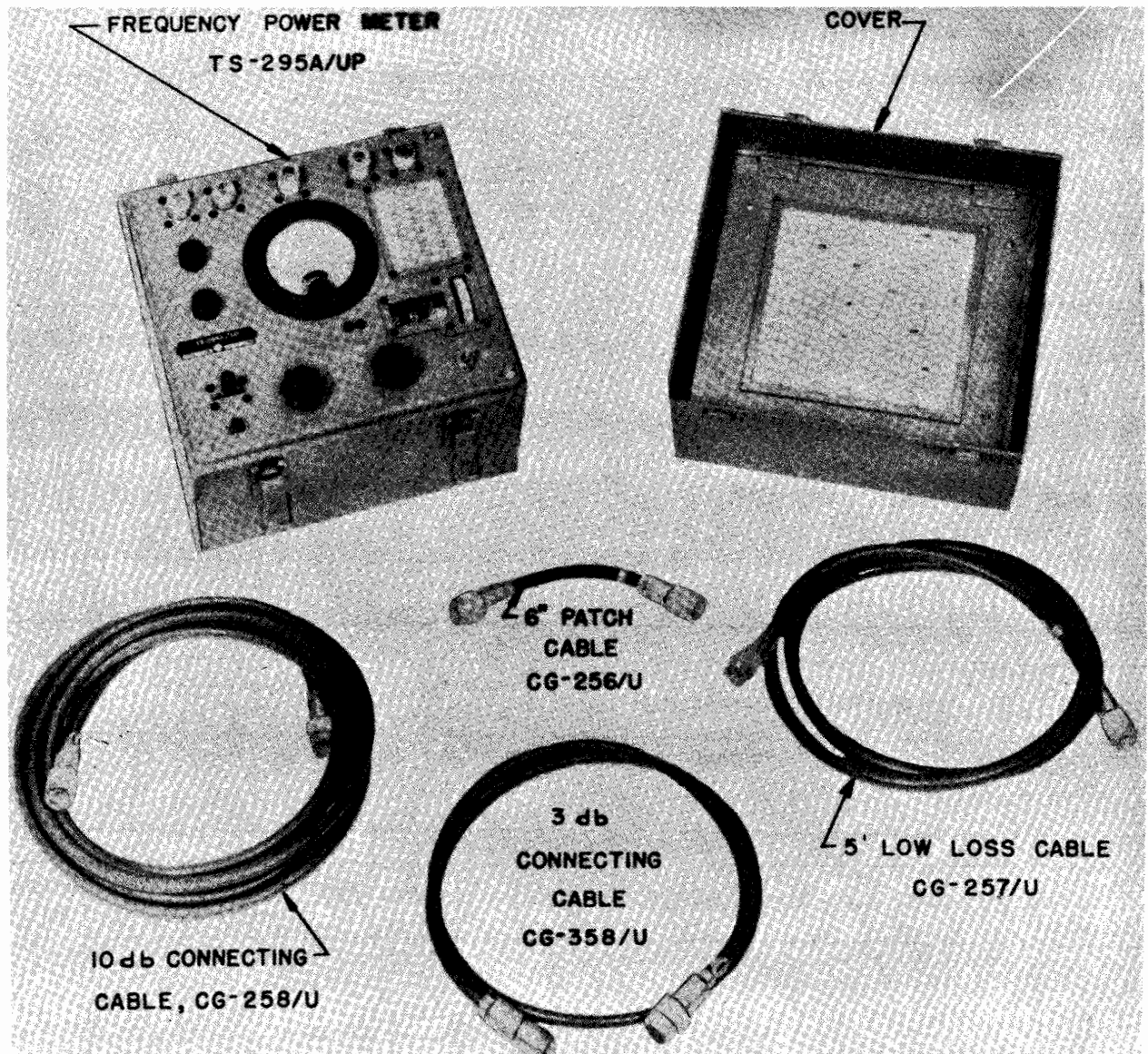

Frequency-Power Meter TS-295A/UP

FUNCTIONAL DESCRIPTION

Frequency-Power Meter TS-295A/UP is a power and frequency measuring set used with an oscilloscope to permit the study of video characteristics of radar signals. It measures frequency by the method of minimum reaction at resonance, as well as CW or pulsed power and frequency by the maximum absorption

method.

No field changes in effect at time of preparation (2 December 1959).

EQUIPMENT REQUIRED BUT NOT SUPPLIED

Battery: (3) BA-30.

UNCLASSIFIED

4.10 TS-295A/UP: 1

Test-Combination and Group

TS-295A/UP

FREQUENCY - POWER METER

ELECTRICAL AND MECHANICAL CHARACTERISTICS

(1) IN21B

POWER REQUIREMENTS: 4.5 v DC.
 FREQUENCY RANGE: 3,400 to 3,900 mc, ± 2 mc.
 POWER RANGE: 0.5 to 12.5 mw (-3 to +11 dbm),
 ± 1 db.
 IMPEDANCE: 50 ohm.
 DC METER RANGE: 0 to 1.5 ma; 0 to 23 mw.
 TEMPERATURE RANGE: -7° to $+50^{\circ}$ C.

Total Crystals: (1)

REFERENCE DATA AND LITERATURE

NAVSHIPS 91164: Technical Manual for FRE-
 QUENCY-POWER METER TS-295A/UP.

MANUFACTURER'S OR CONTRACTOR'S DATA

Washington Institute of Technology Inc.,
 Washington, D. C.
 Contract NObsr-39288, dated 17 June
 1947.

TYPE CLASSIFICATION (NAVY) STD
 DESIGN COGNIZANCE USN, BUSHIPS
 PROCUREMENT COGNIZANCE NAVY SPEC: CS-678
 STOCK NO.
 R.D.B. IDENT. NO. 10.1.1

TUBE AND/OR CRYSTAL COMPLEMENT

No Electron Tubes used.

SHIPPING DATA

NUMBER OF BOXES	CONTENTS AND IDENTIFICATION	VOLUME (Cu.Ft.)	OVERALL DIMENSIONS (inches)	WEIGHT PACKED (lbs.)
1	Frequency-Power Meter TS-295A/UP	3.0	14-5/8 X 16-7/8 X 21-3/8	95

EQUIPMENT SUPPLIED DATA

QUANTITY PER EQUIPT	NAME AND NOMENCLATURE	OVERALL DIMENSIONS (inches)	WEIGHT (lbs.)
1	Frequency-Power Meter TS-295A/UP including:	9-1/4 X 9-3/8 X 11-3/8	12.5
1	Cable CG-256/U		
1	Cable CG-257/U		
1	Cable CG-258/U		
1	Cable CG-358/U		
2	Technical Manuals NAVSHIPS 91164		
1	*Equipment Spare Parts	6-1/2 X 10-1/8 X 13-1/4	17.5
	*Crated with Frequency-Power Meter		

RADAR TEST SET

TS-295B/UP

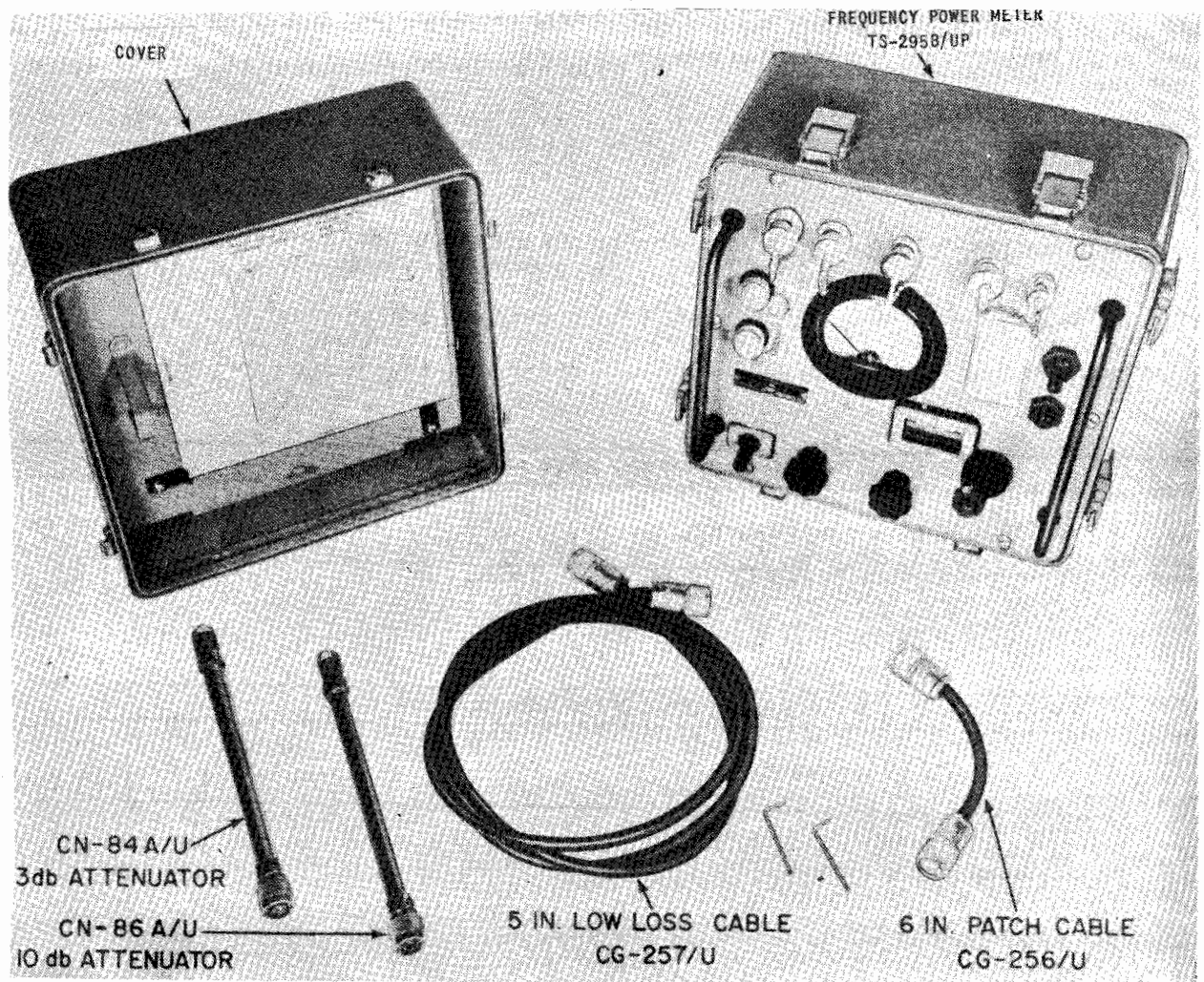

Frequency-Power Meter TS-295B/UP

FUNCTIONAL DESCRIPTION

Radar Test Set TS-295B/UP is a power and frequency measuring set used with an oscilloscope to permit the study of video characteristics of radar signals. It measures frequency by the method of minimum reaction at resonance, as well as CW or pulsed power and frequency by the maximum absorption method.

No field changes in effect at time of preparation (2 December 1959).

EQUIPMENT REQUIRED BUT NOT SUPPLIED

Battery: (3) BA-30.

ELECTRICAL AND MECHANICAL CHARACTERISTICS

POWER REQUIREMENTS: 4.5 v DC.
FREQUENCY RANGE: 3,400 to 3,900 mc, ± 2 mc.
POWER RANGE: 0.5 to 12.5 mw (-3 to +11 dbm), ± 1 db.
IMPEDANCE: 50 ohms.
DC METER RANGE: 0 to 1.5 ma; 0 to 23 mw.
TEMPERATURE RANGE: -7° to $+50^{\circ}$

MANUFACTURER'S OR CONTRACTOR'S DATA

Gibbs Manufacturing and Research Corp.,

Test-Combination and Group

February 1960

TS-295B/UP**RADAR TEST SET**

Janesville, Wisconsin.

Contract NObsr-71130, dated 2 December
1955.**REFERENCE DATA AND LITERATURE**NAVSHIPS 93060: Technical Manual for RADAR
TEST SET TS-295B/UP.**TUBE AND/OR CRYSTAL COMPLEMENT**

No Electron Tubes used.

(1) 1N21B

Total Crystals: (1)

TYPE CLASSIFICATION (NAVY) DESIGN COGNIZANCE USN, BUSHIPS PROCUREMENT COGNIZANCE spec; SHIPS-T-2074 STOCK NO. R.D.B. IDENT. NO. 10.1.1

SHIPPING DATA

NUMBER OF BOXES	CONTENTS AND IDENTIFICATION	VOLUME (Cu.Ft.)	OVERALL DIMENSIONS (inches)	WEIGHT PACKED (lbs.)
1	Frequency-Power Meter TS-2958/UP	3.0	14-5/8 X 16-7/8 X 21-3/8	95

EQUIPMENT SUPPLIED DATA

QUANTITY PER EQUIPT	NAME AND NOMENCLATURE	OVERALL DIMENSIONS (inches)	WEIGHT (lbs.)
1	Frequency-Power Meter TS-2958/UP including:	9-1/4 X 9-3/8 X 11-3/8	12.5
1	Attenuator, 3 db CN-84A/U		
1	Attenuator, 10 db CN-86A/U		
1	Patch Cable CG-256/U		
1	Cable, Low Loss CG-257/U		
2	Technical Manual NAVSHIPS 93060		
1	Equipment Spare Parts		

RADAR TEST SET

TS-295C/UP

FREQUENCY-POWER METER TS-295C/UP

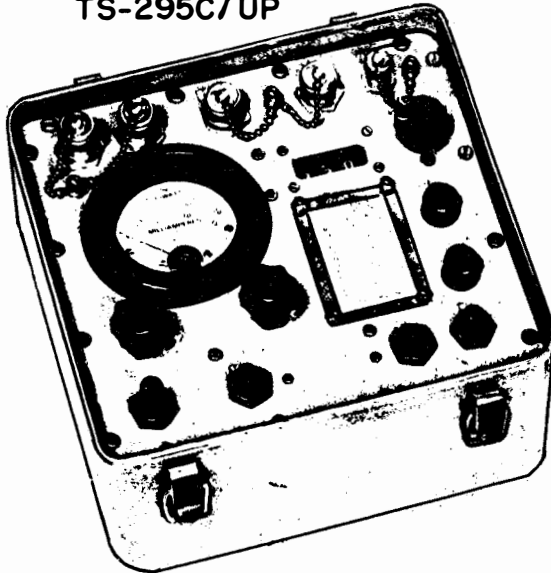

COVER



6" PATCH CABLE
R6-5B/U



10db ATTENUATOR
CN-86A/U



5' LOW LOSS
CABLE
R6-5B/U



3db ATTENUATOR
CN-84A/U

Radar Test Set TS-295C/UP

FUNCTIONAL DESCRIPTION

Radar Test Set TS-295C/UP is a power and frequency measuring set used with an oscilloscope to permit the study of video characteristics of radar signals. It measures frequency by the method of minimum reaction at resonance, as well as CW or pulsed power and

frequency by the maximum absorption method. No field changes in effect at time of preparation (18 July 1960).

RELATION TO OTHER EQUIPMENT

This equipment is the same as the TS-

Test-Combination and Group

TS-295C/UP

RADAR TEST SET

295A/UP, except that it is moistureproof. This has required relocation and redesign of some controls to prevent passage of moisture. An added interlock switch renders the equipment inoperative when cover is in place.

Part/Dwg No. C-57199-M-2.
Contract NObsr-71841, dated 20 June 1957.
Approximate Cost \$474.00.

EQUIPMENT REQUIRED BUT NOT SUPPLIED

Battery: (3) BA-30.

TUBE AND/OR CRYSTAL COMPLEMENT

No Electron Tubes used.

(1) 1N21B
Total Crystals: (1)

ELECTRICAL AND MECHANICAL CHARACTERISTICS

POWER REQUIREMENTS: 4.5 v dc.
FREQUENCY RANGE: 3,400 to 3,900 mc, perm 2 mc.
POWER RANGE: 0.5 to 12.5 mw (M3 to P11 dbm), perm 1 db.
IMPEDANCE: 50 ohms.
DC METER RANGE: 0 to 1.5 ma; 0 to 23 mw.
TEMPERATURE RANGE: M7 deg to P50 deg C.

REFERENCE DATA AND LITERATURE

NAVSHIPS 91164: Technical Manual for RADAR TEST SET TS-295A/UP and TS-295C/UP.

MANUFACTURER'S OR CONTRACTOR'S DATA

Production Research Corp., Thornwood, New York.

TYPE CLASSIFICATION (NAVY)
DESIGN COGNIZANCE USN, BUSHIPS
PROCUREMENT COGNIZANCE SPEC:
STOCK NO. SHIPS-T-2637
R.D.B. IDENT. NO. 10.1.1

SHIPPING DATA

NUMBER OF BOXES	CONTENTS AND IDENTIFICATION	VOLUME (Cu.Ft.)	OVERALL DIMENSIONS (inches)	WEIGHT PACKED (lbs.)
1	Radar Test Set TS-295C/UP	3.0	14-5/8 x 16-7/8 x 21-3/8	95

EQUIPMENT SUPPLIED DATA

QUANTITY PER EQUIPT	NAME AND NOMENCLATURE	OVERALL DIMENSIONS (inches)	WEIGHT (lbs.)
1	Frequency-Power Meter TS-295C/UP including:	9-1/4 x 9-3/8 x 11-3/8	12.5
1	Antenuator, 3 db CN-84A/U		
1	Antenuator, 10 db CN-86A/U		
1	Patch Cable CG-256/U		
1	Cable, Low Loss CG-257/U		

TEST SET

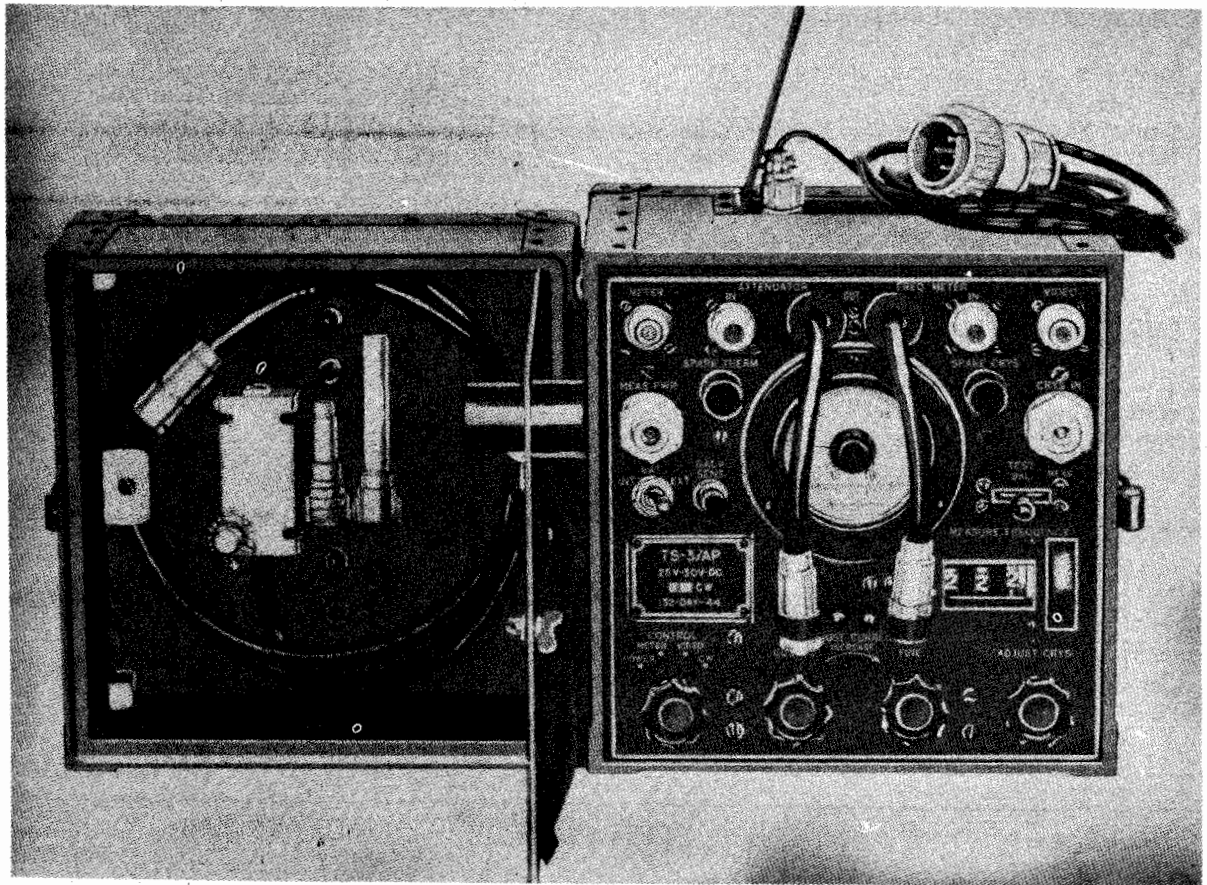

Test Set TS-3/AP

FUNCTIONAL DESCRIPTION

The TS-3/AP and TS-3A/AP are portable instruments used in measuring converter crystal current of certain radar systems, as well as power and frequency of radar transmitters, of beat-frequency oscillators in radar receivers, and of test signal generators. With an external signal generator and a separate IF amplifier, it may be used in measuring the sensitivity or radar receivers.

No field changes in effect at time of preparation (14 April 1958).

RELATION TO OTHER EQUIPMENT

Equipment Required but not Supplied: (3) Battery BA-30.

UNCLASSIFIED

ELECTRICAL AND MECHANICAL CHARACTERISTICS

FREQUENCY RANGE

TS-3/AP: 2,700 to 3,400 mc.

TS-3A/AP: 2,400 to 3,400 mc.

INPUT POWER RANGE: 0.5 to 12.5 mw (-3 to +11 dbm).

IMPEDANCE: 50 to 72 ohms.

DC METER RANGE: 0 to 2 ma.

POWER ACCURACY: ± 0.5 db nominal.

FREQUENCY ACCURACY: ± 1 mc (relative).

POWER REQUIREMENTS: (3) batteries 1.5 v.

TEMPERATURE RANGE: -40 deg C to +50 deg C.

MANUFACTURER'S OR CONTRACTOR'S DATA

Western Electric Co., New York, N. Y.
TS-3/AP:

TS-3/AP, TS-3A/AP

TEST SET

Order No. 4643-ARL-43, dated 17 November 1943.
 Order No. 132-DAY-44, dated 17 November 1945.
 Order No. 267-DAY-44.
 Mfr Spec No. X-61714B.
 TS-3A/AP:
 Order No. 89-DAY-DE-RA.
 Mfr Spec No. X-61714C

REFERENCE DATA AND LITERATURE

AN 16-35TS3-3: Handbook of Maintenance Instructions for Test Sets TS-3/AP and TS-3A/AP.

TUBE AND/OR CRYSTAL COMPLEMENT

No Electron Tubes Used.
 (1) 1N21B
 Total Crystals: (1)

TYPE CLASSIFICATION DESIGN COGNIZANCE USAF PROCUREMENT COGNIZANCE STOCK NO. R.D.B. IDENT. NO.

SHIPPING DATA

NUMBER OF BOXES	CONTENTS AND IDENTIFICATION	VOLUME (Cu.Ft.)	OVERALL DIMENSIONS (inches)	WEIGHT PACKED (lbs.)
1	Test Set TS-3/AP or TS-3A/AP	4.45	16 x 20 x 24	60

EQUIPMENT SUPPLIED DATA

QUANTITY PER EQUIPT	NAME AND NOMENCLATURE	OVERALL DIMENSIONS (inches)	WEIGHT (lbs.)
1	Test Set TS-3/AP or TS-3A/AP including:	8-3/4 x 9-1/4 x 10-3/8	16
1	Technical Manual AN16-35TS3-3		
1	Cord CG-23/AP	156 lg	
1	Cord CG-24/AP	60 lg	
1	Cord CG-381/U	60 lg	
1	Cord CX-68/AP	120 lg	
1	Case CY-45/AP	10-1/2 x 10-1/2 x 14-1/2	
1	Adapter UG-7/AP	5/8 dia x 2-3/32	
1	Adapter UG-8/AP	3/4 dia x 2-1/2	
1	Hex Wrench No. 8		
1	Neon Lamp RCA 991		

TEST SET

TS-306/ARW

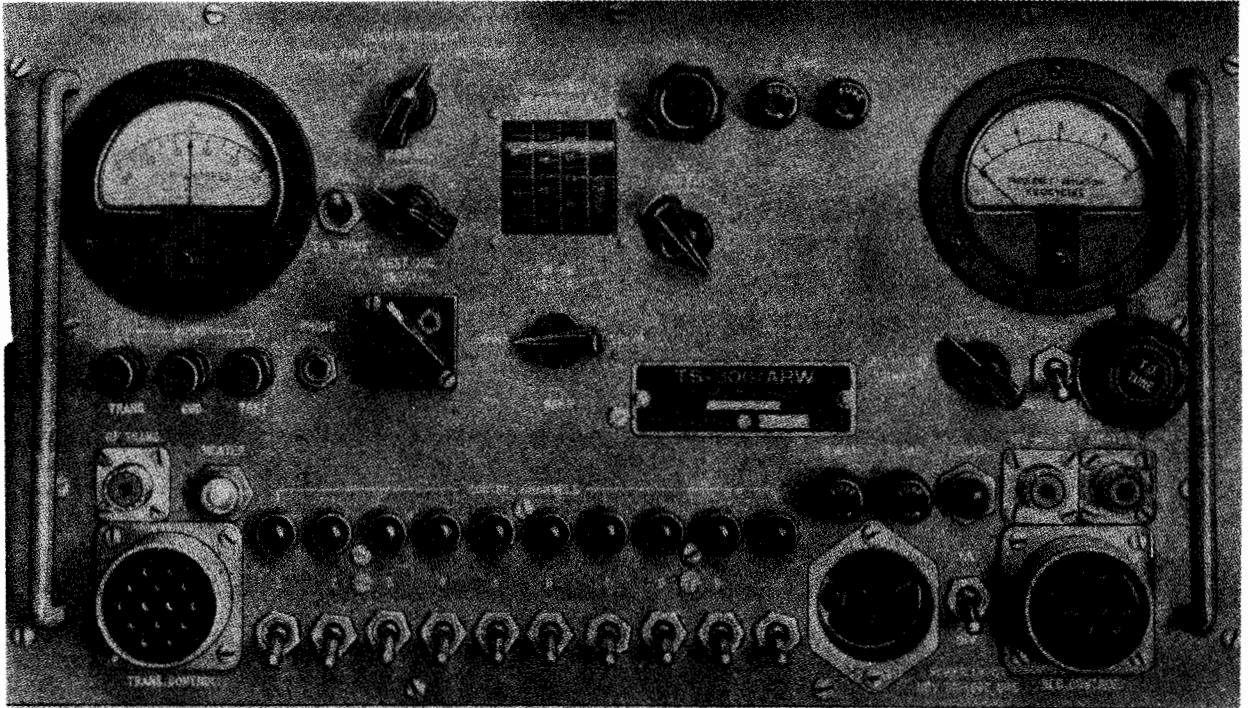

Test Set TS-306/ARW

FUNCTIONAL DESCRIPTION

The TS-306/ARW is used in adjusting the tone oscillator circuits and carrier frequency deviation of FM special control transmitters, in aligning tuned circuits, and in operating tone channel relays of certain FM receivers.

No field changes in effect at time of preparation (30 April 1958).

RELATION TO OTHER EQUIPMENT

Equipment Required but not Supplied: (1) Oscilloscope, (1) Test Meter Unit Type 1623, (1) Headset HS-16-A.

ELECTRICAL AND MECHANICAL CHARACTERISTICS

FREQUENCY RANGE

MONITOR RECEIVER: 30 to 75 mc $\pm 0.5\%$.

TEST OSCILLATOR: 30 to 75, 132 to 140 mc $\pm 0.5\%$

MODULATION: FM, ± 15 kc from 30 to 75 mc, and

± 45 kc from 132 to 140 mc.

TONE CHANNEL FREQUENCIES: 300, 420, 590, 830, 1155, 1620, 2270, 3180, 4450, 6230 cps.

MONITOR SENSITIVITY: 3 mv approx.

TEST OSCILLATOR OUTPUT: 20 to 5000 uv, variable.

POWER SOURCE REQUIRED: 115 v, 1 ph, 50 to 1600 cps, 90 W.

MANUFACTURER'S OR CONTRACTOR'S DATA

Fred M. Link, New York, N. Y.

Contract N5sa-4660.

Approximate Cost: \$400.00 with equipment spares.

TUBE AND/OR CRYSTAL COMPLEMENT

(1) 0D3/VR-150

(1) 5U4G

(23) 6AK5

(1) 6AL5

(1) 6C4

(1) 6J6

Total Tubes: (28)

(2) 1N34

Total Crystals: (2)

TS-306/ARW

TEST SET

REFERENCE DATA AND LITERATURE

AN16-35TS306-3: Handbook of Maintenance Instructions for Test Set TS-306/ARW and Dummy Load TS-307/ARW.

TYPE CLASSIFICATION	
DESIGN COGNIZANCE	BUAER
PROCUREMENT COGNIZANCE	Spec. No. C3-67A
STOCK NO.	
R.D.B. IDENT. NO.	

EQUIPMENT SUPPLIED DATA

QUANTITY PER EQUIPT	NAME AND NOMENCLATURE	OVERALL DIMENSIONS (inches)	WEIGHT (lbs.)
1	Test Set TS-306/ARW	9-13/16 X 16-1/8 X 17-1/8	41.0
1	Dummy Load TS-307/ARW	3-3/4 X 5-1/2 X 6-1/2	1.75
1	Case CY-582/ARW	13-7/16 X 18-21/32 X 27-21/32	23.0
1	Cord CX-337/U	72 lg	1.0
1	Control Table 1855-9	72 lg	1.75
1	Cord CG-91/U 1855-24	72 lg	0.75
1	Cord CG-91/U 1855-23	36 lg	0.4
1	Adaptor Cable Assembly 1855-7	63 lg	0.1
1	Adaptor Cable Assembly 1855-8	63 lg	0.1
1	Adaptor UG-255/U	11/16 dia X 1-3/8	0.1
1	Technical Manual AN16-35TS306-3		

UNCLASSIFIED

March 1957

TEST SET

Test Combination and Group
TS-345/ART-22,345A/ART-22

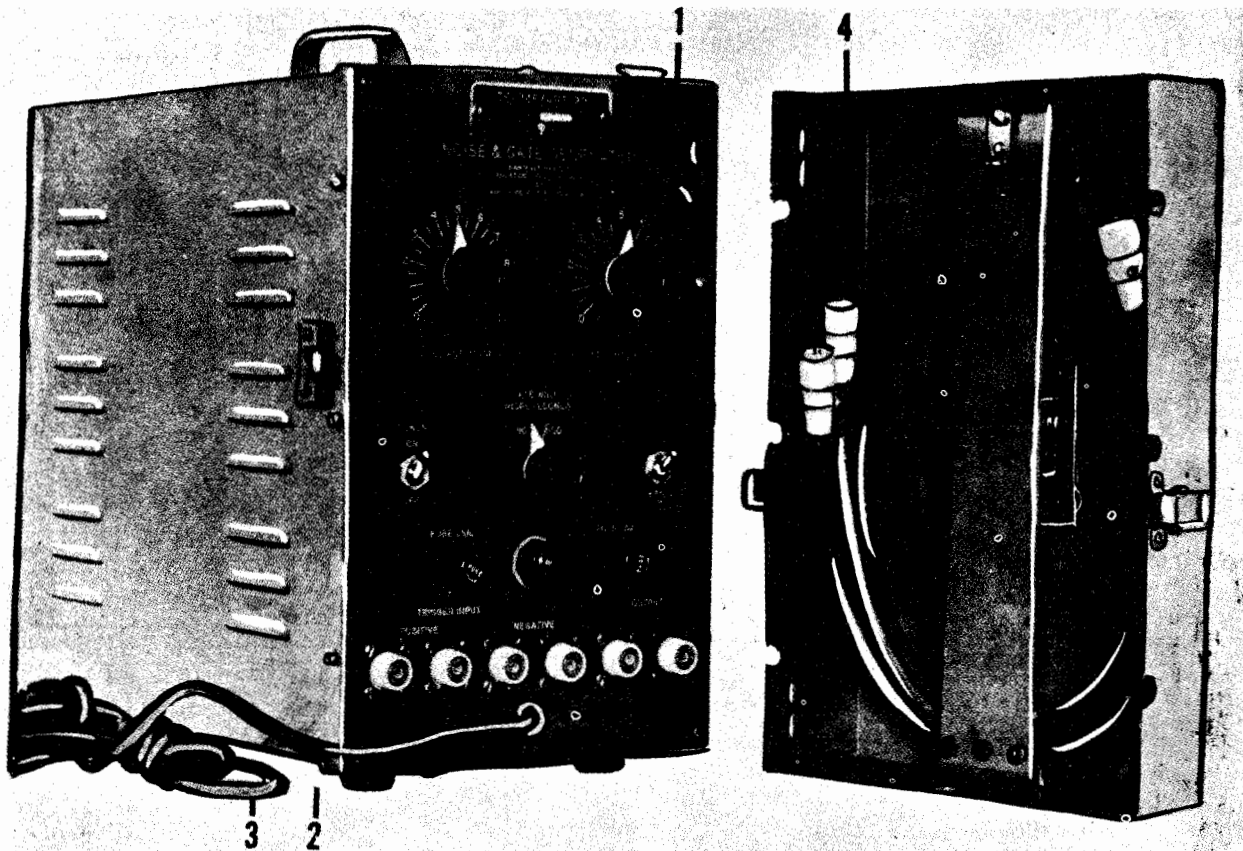

Test Set TS-345/ART-22, TS-345A/ART-22

FUNCTIONAL DESCRIPTION

The TS-345/ART-22 and TS-345A/ART-22 are noise and gate generators designed for checking the performance of Relay Transmitter T-123/ART-22 of the Cadillac system under either 120 or 1110 usec. The production of the gate depends upon an external trigger, and the gate lags the trigger by 500 usec. The noise is eliminated during the gate.

Provision is made for connection to the test set of a positive trigger from the Cadillac synchronizer, or a negative trigger from some other source. Additional Connectors are provided so that the test set may be connected into the Cadillac system without interfering with the operation. Two types of output are provided, negative video signals to the relay transmitter and positive video signals to the Cadillac synchronizer. The noise and gate amplitudes are adjustable. These two sets are interchangeable.

No field changes in effect at time of preparation (5 October 1956).

ELECTRICAL AND MECHANICAL CHARACTERISTICS

TYPE SIGNAL: Noise.

GATE WIDTH: 120 or 1110 usec.

EXTERNAL TRIGGER

AMPLITUDE: ± 35 to ± 200 v.

RATE: 300 pps.

PEAK OUTPUT: -1.5 v to relay transmitter, and 6 v to the Cadillac synchronizer.

OPERATING POWER: 115 v, 50 to 1600 cps, single ph, 100 W.

MANUFACTURER'S OR CONTRACTOR'S DATA

(TS-345/ART-22) Harvey-Wells Communication
Inc, Southbridge, Mass.
Contract 5&A-13494.

UNCLASSIFIED

4, 10 TS-345/ART-22: 1

Test Combination and Group

TS-345/ART-22,345A/ART-22**TEST SET**

March 1957

(TS-345A/ART-22) Hazeltine Electronic
Corp, Long Island, N.Y.
Contract N343s-8023.

REFERENCE DATA AND LITERATURE

NAVAER 16-6Q-503: Technical Manual for Test
Set Noise and Gate Generator" TS-345/
ART-22.

NAVAER 16-35TS345-501: Technical Manual for
Test Set TS-345A/ART-22.

TUBE AND/OR CRYSTAL COMPLEMENT

TS-345/ART-22

(1) 6SL7GT	(4) 6SN7
(1) 6D4	(1) 5R4GY
(2) OC3	(1) 6X5
(1) OD3	

Total Tubes: (11)

TS-345A/ART-22

(2) 6SL7GT	(4) 6SN7GT
(1) 6D4	(1) 5R4GY
(2) OC3	(1) 6X5-GT/G
(1) 6AS7-G	(1) 6SJ7

Total Tubes: (13)

TYPE CLASSIFICATION
DESIGN COGNIZANCE BUAER
PROCUREMENT COGNIZANCE
STOCK NO.
R.D.B. IDENT. NO.

EQUIPMENT SUPPLIED DATA

QUANTITY PER EQUIPT	NAME AND NOMENCLATURE	OVERALL DIMENSIONS (inches)	WEIGHT (lbs.)
1	Test Set TS-345/ART-22 or TS-345A/ART-22	8 X 16 X 13	35
2	R F Cable CG-108/APN		
1	Cord CX-337A/U		
1	Allen Wrench #8		

April 1958

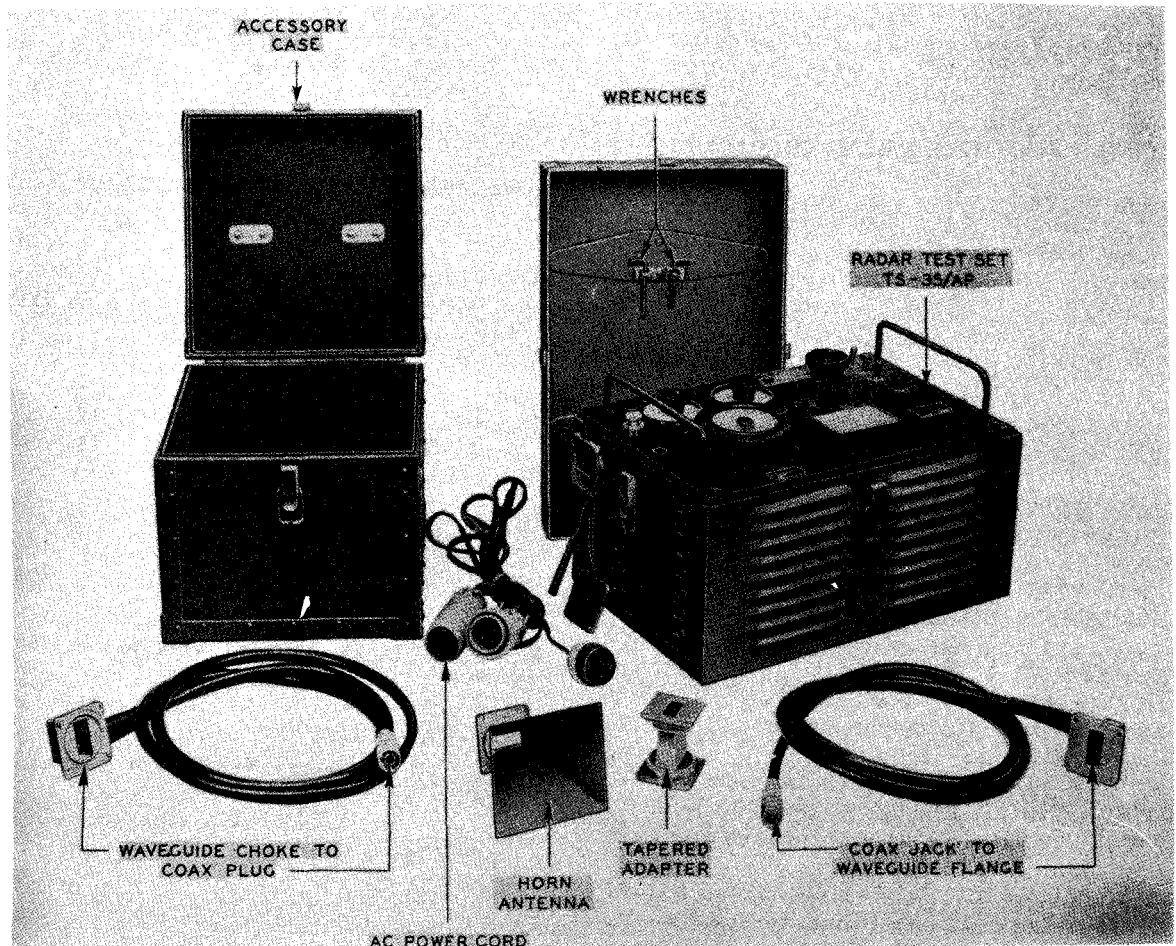
SIGNAL GENERATOR**TS-35,-A/AP***Signal Generator TS-35,-A/AP***FUNCTIONAL DESCRIPTION**

The TS-35/AP and TS-35A/AP are general purpose sets designed for the testing and general maintenance of radar equipments. The TS-35/AP is used with radar equipments operating in the frequency range from 8700 to 9500 megacycles while the TS-35A/AP tests radars which cover the 8500 to 9600 megacycle range.

Their main functions are to generate SHF signals of known frequency and power, either unmodulated, pulse modulated or frequency modulated with or without synchronization; to detect and measure the frequency and average power of modulated or unmodulated SHF

signals; to detect radar signals and observe the video waveshapes of radar transmitters or receivers with the help of an oscilloscope; and to determine the receiver recovery characteristics.

The TS-35/AP and TS-35A/AP are similar except for differences in frequency range and minor design improvements.

No field changes in effect at time of preparation (18 November 1957).

RELATION TO OTHER EQUIPMENT

The TS-35/AP and TS-35A/AP are replaced by Test Set TS-147/UP.

Test-Combination or Group

TS-35,-A/AP**SIGNAL GENERATOR**

April 1958

Equipment Required but not Supplied: For certain tests, an oscilloscope such as the TS-34/AP or TS-239/UP is required.

Order No. 870-DAY-45RA.

Contract NOrd 4748.

Contract NOrd-3644.

Contract NOrd-5557.

ELECTRICAL AND MECHANICAL CHARACTERISTICS**FREQUENCY RANGE**TS-35/AP: 8700 to 9500 mc ± 5 mc.TS-35A/AP: 8500 to 9600 mc ± 5 mc.

TEMPERATURE RANGE: -40 to +50 deg C.

POWER RANGE

POWER METER: 0.1 mw to 2 W avg.

SIG GENERATOR: 0 to 70 db below 1 mw peak, cw or pulsed.

MAX INPUT POWER

FREQ METER AND POWER METER: 200 W peak or 2 W avg.

SYNC INPUT: 2 v peak w/xtal in.

VIDEO DETECTOR: 0.25 W.

MINIMUM INPUT POWER

FREQ METER AND POWER METER: 0.1 mw avg.

SIG GENERATOR AND VIDEO DETECTOR: 0.8 v peak for 1 usec pulse.

TYPE OF INDICATION

FREQ METER: Min on DC meter.

POWER METER, SIG GENERATOR AND VIDEO DETECTOR: Linear reading on DC meter up to 1 mw db on attenuator dial above 1 mw.

INT PULSE CHARACTERISTIC

UNSYNCHRONIZED: 2 usec pulses every 8 usec.

SYNCHRONIZED: 7 usec on, 10 usec off followed by 2 usec pulses every 8 usec.

FM CHARACTERISTIC: 20 mc sweep every 8 usec centered on tuned freq.

POWER SOURCE REQUIRED: 105 to 125 v, 50 to 1600 cps, 200 W.

MANUFACTURER'S OR CONTRACTOR'S DATA

Western Electric Co, New York, N.Y.

Order No. 768-DAY-4SRA and 870-DA-4SRA (TS-35/AP).

TUBE AND/OR CRYSTAL COMPLEMENT

TS-35/AP

(1) OD3W (1) 6V6GT (2) 6SN7WGTA

(2) 6X5WGT (1) 6SL7WGT (1) 2K25

Total Tubes: (8)

TS-35A/AP

(1) OD3W (1) 2K25 (2) 6SL7WGT

(1) 6V6GT (3) 6X5WGT (3) 6SN7WGTA

Total Tubes: (11)

(1) 1N21B

Total Crystals: (1)

REFERENCE DATA AND LITERATURE

SHIPS 284; Technical Manual for Test Equipment TS-35/AP.

SHIPS 339, Technical Manual for Signal Generator TS-35A/AP

TYPE CLASSIFICATION
DESIGN COGNIZANCE
PROCUREMENT COGNIZANCE
STOCK NO.
R.D.B. IDENT. NO.

SHIPPING DATA

NUMBER OF BOXES	CONTENTS AND IDENTIFICATION	VOLUME (Cu.Ft.)	OVERALL DIMENSIONS (inches)	WEIGHT PACKED (lbs.)
1	Signal Generator w/Accessories (TS-35/AP)	2.6	12 x 15 x 25	45

UNCLASSIFIED

Test-Combination and Group

April 1958

SIGNAL GENERATOR

TS-35,-A/AP

EQUIPMENT SUPPLIED DATA

QUANTITY PER EQUIPT	NAME AND NOMENCLATURE	OVERALL DIMENSIONS (inches)	WEIGHT (lbs.)
1	TS-35/AP Signal Generator TS-35/AP c/o (1) Case CY-94/AP (1) Horn Antenna, AT-39/AP (1) Cord CG-60/AP (1) Cord CG-61/AP (1) Adapter MX-135/AP (1) Cord CX-128/AP	9-3/4 x 11-3/8 x 14-1/4	28 6.2
1	TS-35A/AP Signal Generator TS-35A/AP	10-5/8 x 11-1/4 x 15-5/8	26.3
1	Accessory Set c/o (1) Carrying Case CY-94/AP (1) Horn Antenna AT-39/AP (1) Cord CG-60/AP (1) Cord CG-61/AP (1) Adapter MX-135/AP (1) Cord CX-128/AP	8-1/4 x 9-5/32 x 9-3/16	6.2 2.5

UNCLASSIFIED

4.10 TS-35/AP: 3

TEST SET

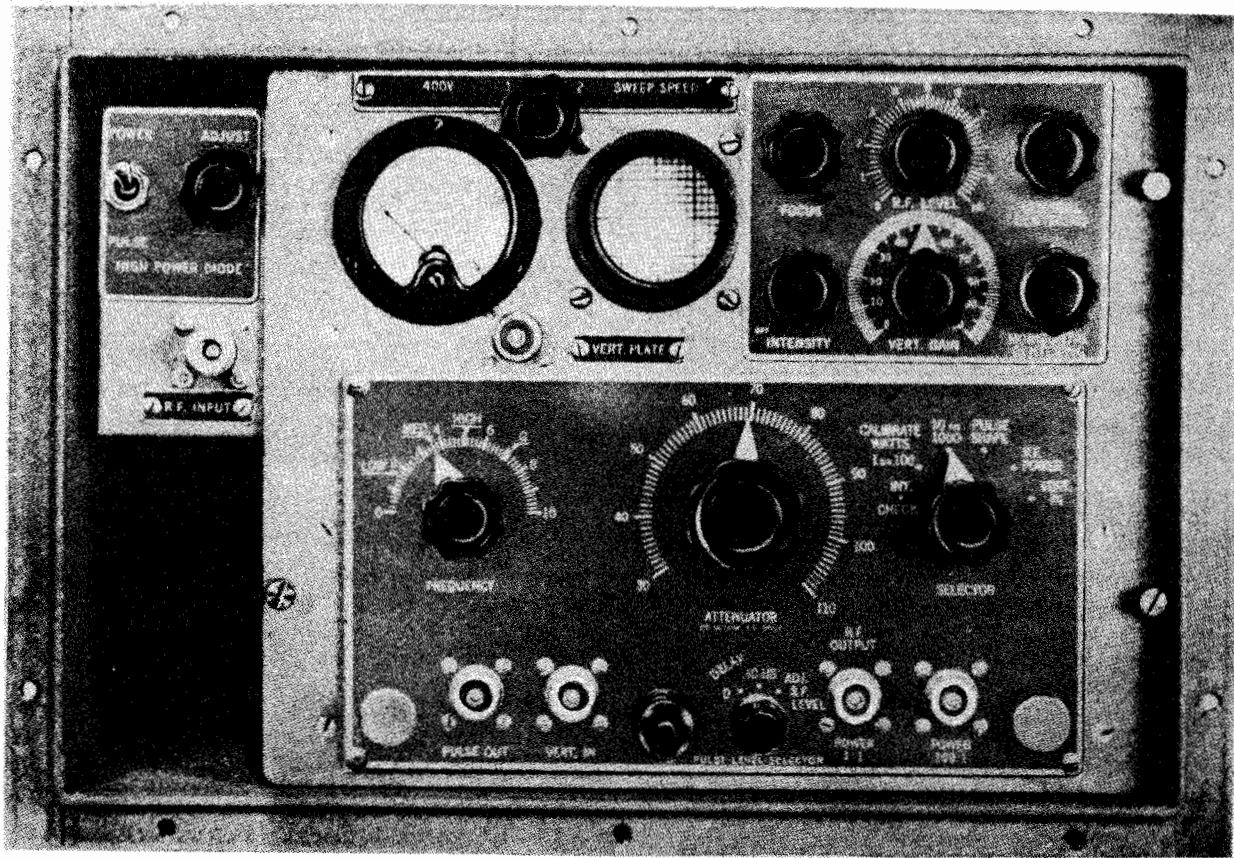

Test Set TS-355A/UP

FUNCTIONAL DESCRIPTION

The TS-355/UP and TS-355A/UP are used in checking the sensitivity of receivers of the power output of transmitters that receive and transmit pulse-modulated signals. The built-in oscilloscope shows pulse shapes of short rf and video pulses. Each equipment consists of a signal generator, power meter, and synchroscope.

No field changes in effect at time of preparation (21 April 1958).

RELATION TO OTHER EQUIPMENT

The TS-355/UP is similar to TS-182/UP but with several circuit modifications. The TS-355A/UP is an improved version of the TS-355/UP; the two models are interchangeable.

ELECTRICAL AND MECHANICAL CHARACTERISTICS

SIGNAL GENERATOR

FREQUENCY RANGE: 150 to 240 mc.
POWER RANGE: 30 to 110 db below 1 v.
IMPEDANCE: 50 ohms.
PULSE DELAY: 40 usec.
ACCURACY: $\pm 25\%$.

OSCILLOSCOPE

FREQUENCY RESPONSE: 50 to 500,000 cy.
IMPEDANCE: 75 ohms.
SWEEP DURATION: 20 to 100 usec.
SWEEP REPETITION RATE: 150 pps.
SYNCHRONIZING PULSE AMPLITUDE: +200 v (peak).
SYNCHRONIZING PULSE: 0 to 40 usec.

POWER MEASUREMENTS

POWER RANGE: 3,000 W.
IMPEDANCE: 50 ohms.
ACCURACY: $\pm 25\%$.

April 1958

Test-Combination and Group

TS-355/UP, TS-355A/UP

TEST SET

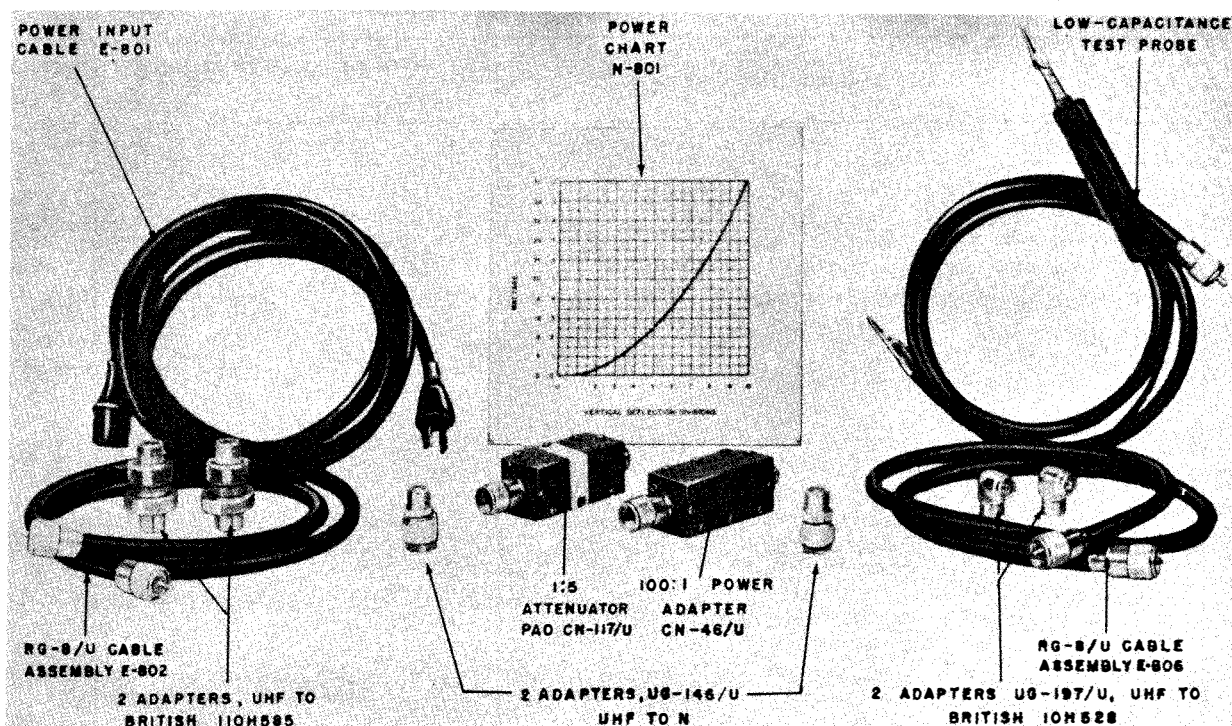

Accessories for TS-355A/UP

SENSITIVITY MEASUREMENTS

POWER RANGE: 30 to 110 db below 1 v.

RECEIVER VIDEO OUTPUT: 1 v (min).

ACCURACY: ± 2 db.POWER REQUIREMENTS: 75 W, 115 v $\pm 5\%$, 50 to 1,200 cps.

(1) 6SL7GT

(1) 6X5GT

Total Tubes: (12)

No Crystals Used.

(4) 6SN7GT

(2) 955

MANUFACTURER'S OR CONTRACTOR'S DATA

Harvey-Wells Electronics Inc, South Bridge,
Mass.

Contract NOas-7871 (TS-355/UP).

Hazeltine Electronics Corp, Little Neck,
L. I., N. Y.

Contract N383s-8023.

Contract N383s-8152 (TS-355A/UP).

REFERENCE DATA AND LITERATURE

NAVSHIPS 900,604: Handbook of Maintenance
Instructions for Test Set TS-355/UP.AN16-35TS355-3: Handbook of Maintenance In-
structions for Test Set TS-355A/UP.

TUBE AND/OR CRYSTAL COMPLEMENT

(1) 2AP1

(1) 6AG7

(1) 5R4GY

(1) 6AL5

TYPE CLASSIFICATION
DESIGN COGNIZANCE BUSHIPS
PROCUREMENT COGNIZANCE
STOCK NO.
R.D.B. IDENT. NO.

UNCLASSIFIED

April 1958

Test-Combination and Group

TEST SET

TS-355/UP, TS-355A/UP

EQUIPMENT SUPPLIED DATA

QUANTITY PER EQUIPT		NAME AND NOMENCLATURE	OVERALL DIMENSIONS (inches)	WEIGHT (lbs.)
TS-355				
/UP A/UP				
1	1	Main Chassis	9-1/4 X 12 X 16	43
1	1	Tuning Unit TN-79/U	5 X 5-1/4 X 9-3/4	5.75
	1	Test Probe	1 dia X 48	0.85
1	1	Transportation Case CY-278/UP	11 X 15 X 17	15
1	1	100: 1 Power Adapter CN-46/U	1-1/4 X 1-1/4 X 4	0.3
	1	High-Power Diode Unit	3 X 4 X 6-1/4	
	1	1: 5 Attenuator Pad CN-117/U	1-1/4 X 1-1/4 X 4	
1	1	1: 5 Attenuator Pad	1 X 1 X 3-3/4	
	1	Line Cord CX-337A/U	180 lg	
1	1	Line Cord	180 lg	
	2	Cable Assy, RG-8/U w/NT-49190 Plug ea. end	3/4 dia X 48	
2	2	Connecting Cable	48 lg	
	2	Adapter UHF to British 110H585	1-1/4 dia X 2-1/8	
2	2	Adapter		
	2	Adapter UHF to British 10H528, UG-197/U	7/8 X 11/16 X 1-1/8	
2	2	Adapter		
	2	Adapter UHF UG-146/U	3/4 dia X 1-3/4	
2	2	Adapter		
1	1	Test Cable	48 lg	
	1	Allen wrench No. 6	1/16 X 9/16 X 1-13/16	
	1	Allen wrench No. 8	5/64 X 11/16 X 1-61/64	
	1	Allen wrench No. 10	3/32 X 3/4 X 2-3/32	
1	1	Power Chart	0.018 X 8 X 8	

UNCLASSIFIED

4.10 TS-355/UP: 3

March 1957

VOLTMETER

Test Combination and Group

TS-375A/U

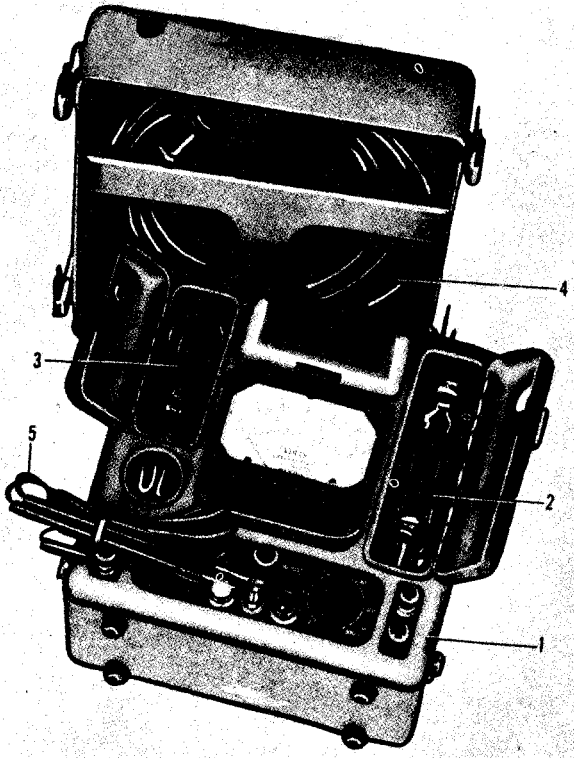

Voltmeter TS-375A/U

FUNCTIONAL DESCRIPTION

The TS-375A/U is a vacuum tube voltmeter which measures both AC and DC and is designed to meet service field conditions.

No field changes in effect at time of preparation (10 August 1956).

RELATION TO OTHER EQUIPMENT

Same as TS-375/U with improved mechanical and electrical characteristics.

ELECTRICAL AND MECHANICAL CHARACTERISTICS

METER RANGE

AC: 0 to 1.2, 3, 12, 30, 120 v.

DC: 0 to 1.2, 3, 12, 30, 120, 300 v.

ACCURACY

AC: 3 to 8% varying with frequency.

DC: 3%.

INPUT IMPEDANCE

AC: 5 meg.

DC: 30 meg.

FREQUENCY RANGE

DIRECT: 40 cps to 50 kc.

PROBE: 10 kc to 150 mc.

POWER REQUIREMENTS: 105 to 125 v, 50 to 1600 cps, single ph, 28 W.

MANUFACTURER'S OR CONTRACTOR'S DATA

Weston Electrical Instrument Corp., Newark, N.J.

Contract NOa(s)-9616, 9402, dated 7 October 1948.

Approximate Cost: \$140.00 with equipment spares.

TUBE AND/OR CRYSTAL COMPLEMENT

(2) 6SJ7

(1) 6SL7

(1) 5Y3GT

(2) 5704

Total Tubes: (6)

REFERENCE DATA AND LITERATURE

NAVAER 08-5S-78: Manual of Test Equipment for Airborne Electrical and Electronic Equipment.

TYPE CLASSIFICATION
DESIGN COGNIZANCE BUAER
PROCUREMENT COGNIZANCE
STOCK NO.
R.D.B. IDENT. NO.

EQUIPMENT SUPPLIED DATA

QUANTITY PER EQUIPT	NAME AND NOMENCLATURE	OVERALL DIMENSIONS (inches)	WEIGHT (lbs.)
1	Voltmeter TS-375A/U	6-3/4 x 10-1/2 x 10-1/2	18.5
1	AC Probe MX-661/U		
1	DC Probe MX-660/U		
1	Line Cord CX-337/U		
2	Test Leads CX-529/U		
1	Ground Prod		
2	Alligator Clips		
1	Box Spare Parts		

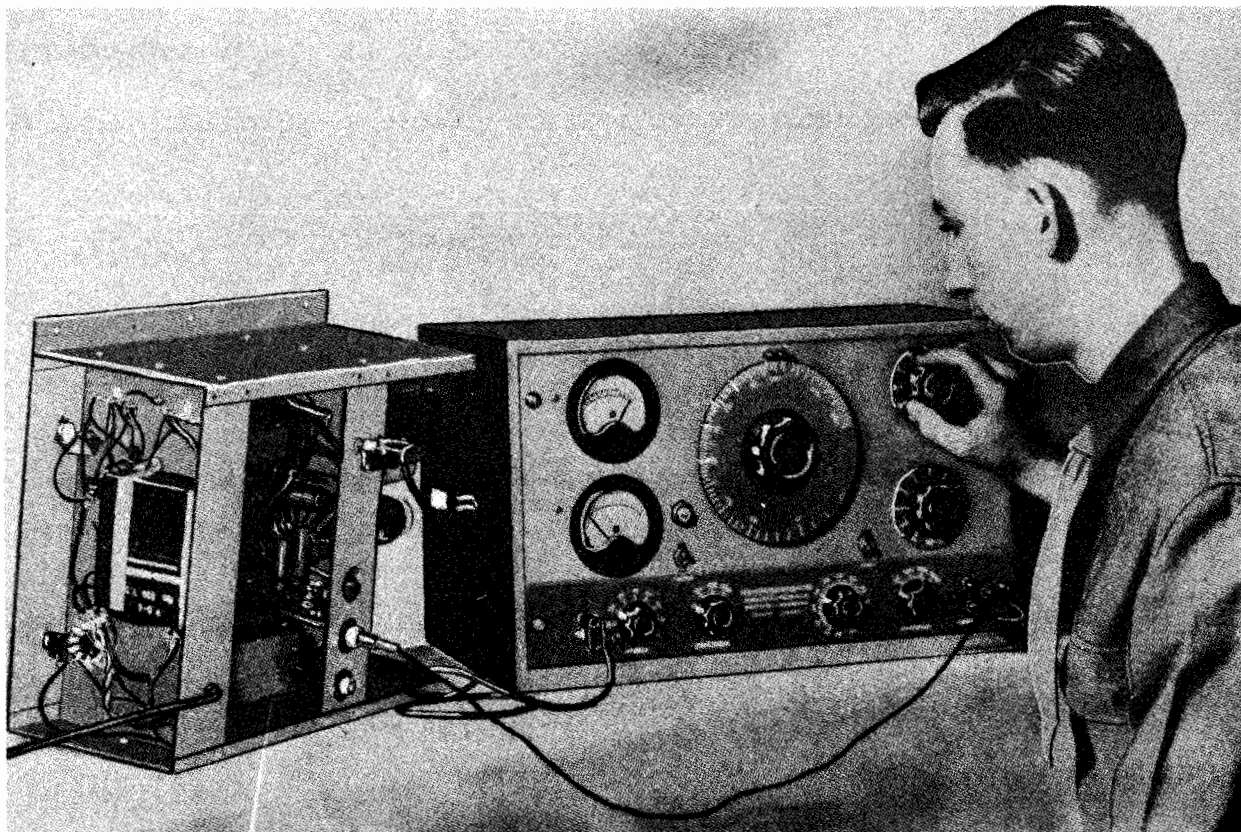

Audio Oscillator TS-421/U, 421A/U

FUNCTIONAL DESCRIPTION

The TS-421/U and TS-421A/U provide AF signals for general test purposes. It may be used to modulate other signal generators or to provide power for transmission line measurements.

The TS-421/U is similar to Audio Oscillator TS-421A/U except the latter includes an input meter for gain measurements.

No field changes in effect at time of preparation (26 June 1956).

ELECTRICAL AND MECHANICAL CHARACTERISTICS

FREQUENCY RANGE: 20 to 20000 cps.
 POWER OUTPUT: 5 W max into matched load.
 OUTPUT IMPEDANCE: 12.5, 50, 125, 200, 1250, 5000 ohms.
 DISTORTION: 1% below 30 cps.
 STABILITY: 2%.
 OUTPUT LEVEL: -20 to +37 dbm.
 OUTPUT ATTENUATOR: 0 to 110 db.
 POWER REQUIREMENTS: 110 to 120 v, 50 to 60 cps. 125 W.

UNCLASSIFIED

MANUFACTURER'S OR CONTRACTOR'S DATA

Hewlett Packard Co., Palo Alto, California.

Approximate Cost: \$325.00 with equipment spares.

TUBE AND/OR CRYSTAL COMPLEMENT

(1) 514	(1) 6F6	(1) 6F8G
(1) 6H6	(1) 6J7	(1) 6L6WGB
(1) 6SF5		

Total Tubes: (7)

REFERENCE DATA AND LITERATURE

TM11-487H Directory of Signal Corps Equipments-Test Equipment.

TYPE CLASSIFICATION
DESIGN COGNIZANCE TASSA
PROCUREMENT COGNIZANCE
STOCK NO.
R.D.B. IDENT. NO.

TS-421/U,421A/U

AUDIO OSCILLATOR

December 1956

SHIPPING DATA				
NUMBER OF BOXES	CONTENTS AND IDENTIFICATION	VOLUME (Cu.Ft.)	OVERALL DIMENSIONS (inches)	WEIGHT PACKED (lbs.)
1	Audio Oscillator TS-421/U or 421A/U with accessories	5		150

EQUIPMENT SUPPLIED DATA			
QUANTITY PER EQUIP	NAME AND NOMENCLATURE	OVERALL DIMENSIONS (inches)	WEIGHT (lbs.)
1	Audio Oscillator TS-421/U or 421A/U	11-5/8 X 13-3/16 X 22-19/32	75

December 1956

ELECTRONIC SWITCH**TS-433/U***Electronic Switch TS-433/U***RELATION TO OTHER EQUIPMENT**

The TS-433/U is similar to Electronic Switch TS-433A/U and Dumont Model 185 and 185A.

ELECTRICAL AND MECHANICAL CHARACTERISTICS

SWITCHING RATE: 10 to 2000 cps.
 FREQUENCY RANGE: 10 to 50 cps, squarewave.
 OUTPUT: 30 v, peak to peak.
 OUTPUT IMPEDANCE: 50000 ohms.
 POWER REQUIREMENTS: 115 to 130 v, 40 to 60 cps, 30 W.

MANUFACTURER'S OR CONTRACTOR'S DATA

Dumont Electric Co., New York, N.Y.
 Approximate Cost: \$150.00 with equipment spares.

TUBE AND/OR CRYSTAL COMPLEMENT

(2) 6SJ7 (2) 6V6
 (2) 6J5 (1) 80
 Total Tubes: (7)

REFERENCE DATA AND LITERATURE

TM11-487H Directory of Signal Corps Equipments, test equipment.

FUNCTIONAL DESCRIPTION

The TS-433/U is a square-wave, AF signal generator. It is used to permit the simultaneous display of two independent signals on the screen of a cathode-ray oscilloscope.

No field changes in effect at time of preparation (26 June 1956).

TYPE CLASSIFICATION
DESIGN COGNIZANCE TASSA
PROCUREMENT COGNIZANCE
STOCK NO.
R.D.B. IDENT. NO.

SHIPPING DATA

NUMBER OF BOXES	CONTENTS AND IDENTIFICATION	VOLUME (Cu.Ft.)	OVERALL DIMENSIONS (inches)	WEIGHT PACKED (lbs.)
1	Electronic Switch TS-433/U	3.5		49

EQUIPMENT SUPPLIED DATA

QUANTITY PER EQUIPT	NAME AND NOMENCLATURE	OVERALL DIMENSIONS (inches)	WEIGHT (lbs.)
1	Electronic Switch TS-433/U	7-3/8 X 11-1/2 X 13	17

UNCLASSIFIED

4.10 TS-433/U: 1

ELECTRONIC SWITCH

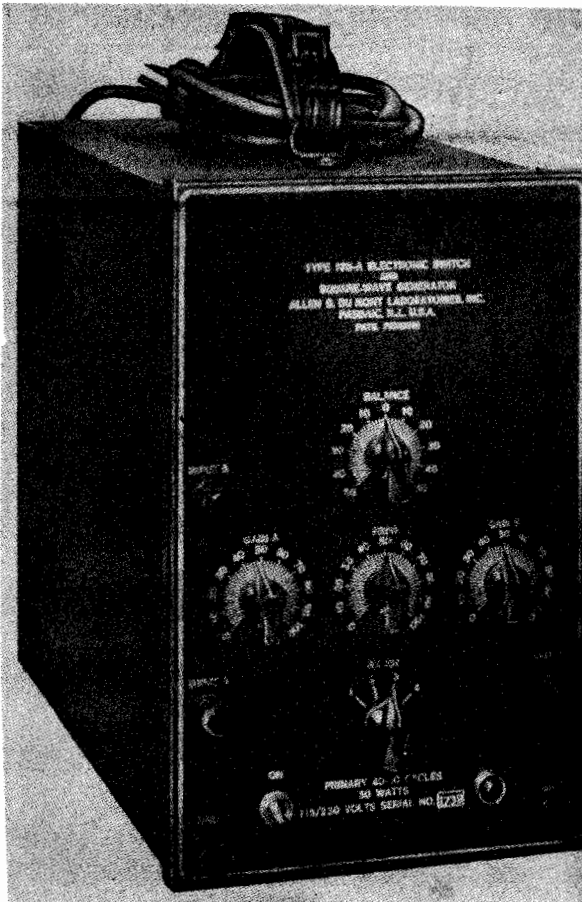

Electronic Switch TS-433A/U

FUNCTIONAL DESCRIPTION

Electronic Switch TS-433A/U and TS-433B/U are auxiliary electronic switches for cathode ray designed to permit the simultaneous observation, for purposes of comparison, of two or more independent signals on the screen of a single beam oscilloscope.

Two input channels are available for the comparison of amplitude, waveform, phase and frequency relationships. By use of two units operated in cascade, up to three independent patterns on a single scope.

The switch equipment is also a square wave generator over the range of 10 to 500 cps, for the testing of amplifiers and other networks.

No field changes in effect at time of preparation (1 May 1958).

RELATION TO OTHER EQUIPMENT

Similar to Du Mont Model 185-A Electronic

Switch.

Equipment Required but not Supplied: (1) Test Oscilloscope.

ELECTRICAL AND MECHANICAL CHARACTERISTICS

SWITCHING RATE: 10 to 2000 times per sec, continuously variable.

FREQUENCY RESPONSE: 0 to 5000 cps, ± 1 db, 25 kc response not more than 25% below 1 kc response.

VOLTAGE GAIN: 10 times.

INPUT IMPEDANCE: 100,000 ohms.

INPUT VOLTS

MAXIMUM ATTENUATION: 150 v rms.

ZERO ATTENUATION

BALANCE: 2.5 v rms.

UNBALANCE: 1.5 v rms.

SQUARE WAVE

FREQUENCY RANGE: 10 to 500 cps.

RISE TIME: 25 usec max at 500 cps.

MAXIMUM OUTPUT: 30 v peak to peak (approx).

MAXIMUM SIGNAL OUTPUT, BALANCE: 75 v peak to peak.

OUTPUT IMPEDANCE: 50,000 ohms.

POWER REQUIREMENTS: 115 or 230 v, 50 to 60 cps, single ph, 30 W.

MANUFACTURER'S OR CONTRACTOR'S DATA

Allen B. DuMont Laboratories, Inc, Passaic, N.J. (TS-433A/U).

Dunbrow Development Co., Burlington, N.J. Order No. 10172-Phila-50 (TS-433B/U).

TUBE AND/OR CRYSTAL COMPLEMENT

TS-433A/U
(2) 6SN7GT (2) 6SJ7GT (1) 5Y3GT
Total Tubes: (5)

TS-433B/U
(2) 6SJ7 (2) 6V6 (2) 6J5
(1) 80

Total Tubes: (7)

No Crystals used.

REFERENCE DATA AND LITERATURE

TS-433A/U

TYPE 185A: Allen B. DuMont Operating and Maintenance Instructions.

TS-433B/U

Technical Manual for Electronic Switch TS-433B/U.

TYPE CLASSIFICATION
DESIGN COGNIZANCE TASSA
PROCUREMENT COGNIZANCE
STOCK NO.
R.D.B. IDENT. NO. 10.1.7

TS-433A/U, TS-433B/U

ELECTRONIC SWITCH

SHIPPING DATA

NUMBER OF BOXES	CONTENTS AND IDENTIFICATION	VOLUME (Cu.Ft.)	OVERALL DIMENSIONS (inches)	WEIGHT PACKED (lbs.)
1	Electronic Switch TS-433A/U or	3.5		49
	Electronic Switch TS-433B/U	2.18	13-1/2 X 15-1/2 X 18	55

EQUIPMENT SUPPLIED DATA

QUANTITY PER EQUIPT	NAME AND NOMENCLATURE	OVERALL DIMENSIONS (inches)	WEIGHT (lbs.)
1	Electronic Switch TS-433A/U or	7-3/8 X 11-3/4 X 13	17
1	Electronic Switch TS-433B/U	8-3/4 X 10 X 13	24

UNCLASSIFIED

October 1957

Test Combination and Group

**RADAR TEST SET
AUXILIARY TEST KIT**

**TS-45/APM-3
TS-76/APM-3**

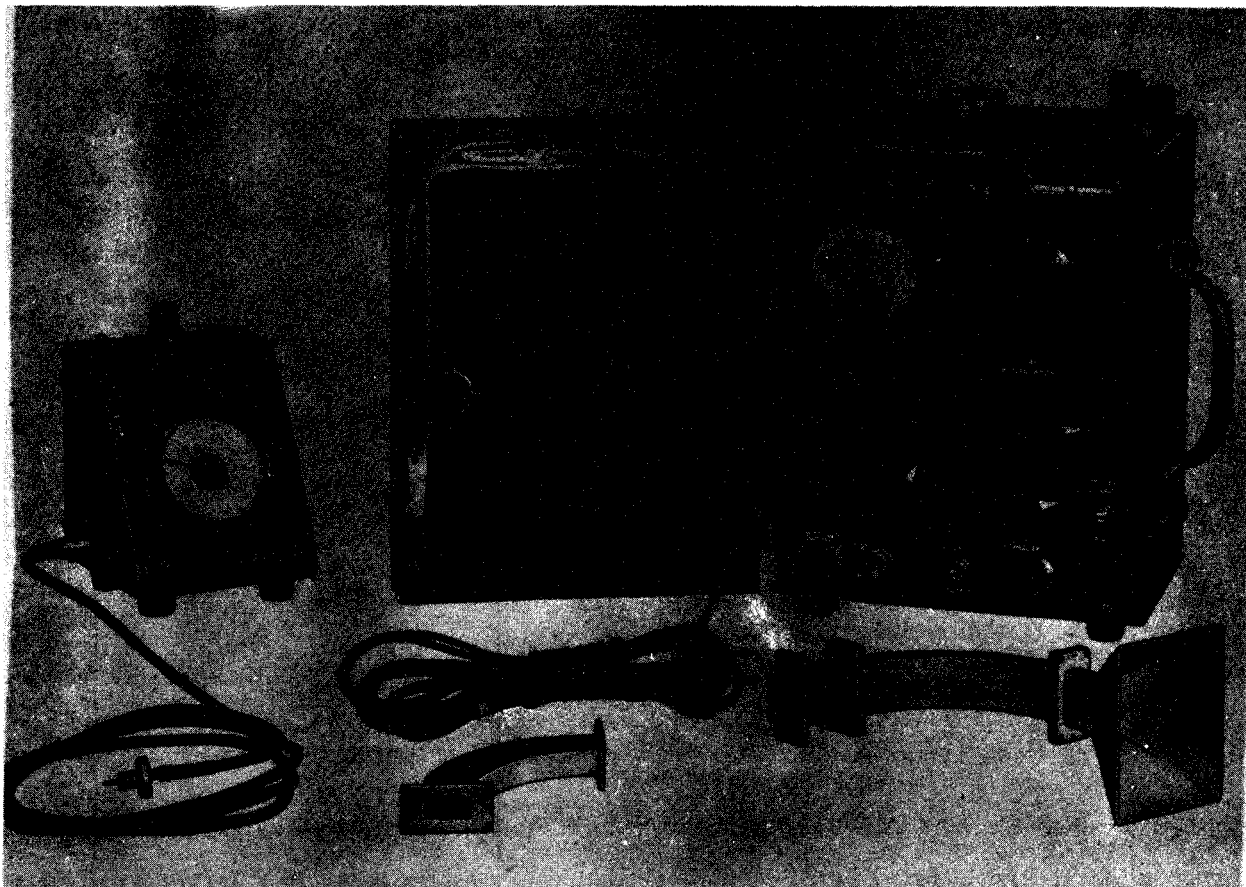

Radar Test Set TS-45/APM-3 & Auxiliary Test Kit TS-76/APM-3

FUNCTIONAL DESCRIPTION

The TS-45/APM-3 and TS-76/APM-3 measure power and frequency in the X-band range. Though designed primarily for testing the transmitters of Radar Set AN/APS-4 and similar equipment, the test set can also be employed as a CW or pulsed signal generator for testing and adjusting the receivers of radar sets operating in the X-band.

No field changes in effect at time of preparation (26 November 1956).

RELATION TO OTHER EQUIPMENT

Equipment Required but not Supplied: (1) Milliammeter, (1) Pulse Generator.

ELECTRICAL AND MECHANICAL CHARACTERISTICS

RADAR TEST SET TS-45/APM-3

POWER OUTPUT: 10 mw.

ACCURACY: ± 2 mc over its 450 mc range.

ACCURACY (when used as Power meter): ± 1.5 db from 0 to 16 db and ± 2.5 db from 16 db to 30 db.

ACCURACY (when used as frequency meter): ± 2 mc and has a range of 450 mc.

OPERATING POWER: 100 to 127 v, 60 to 800 cps, single ph, 45 W.

MANUFACTURER'S OR CONTRACTOR'S DATA

Western Electric Company, New York, N.Y.
Contract NXsa 32197.

UNCLASSIFIED

4.10 TS-45/APM-3: 1

Test Combination and Group

October 1957

**TS-45/APM-3
TS-76/APM-3****RADAR TEST SET
AUXILIARY TEST KIT****TUBE AND/OR CRYSTAL COMPLEMENT**Radar Test Set TS-45/APM-3 and Auxiliary
Test Kit TS-76/APM-3.

(2) 6X5GT/G (1) 6V6GT/G
 (1) 6SL7GT (2) OC3/VR-105
 (1) W.E. Co. 723A

Total Tubes: (7)

REFERENCE DATA AND LITERATURE

CO-AN08-35TS45-2-M: Technical Manual for

TYPE CLASSIFICATION
DESIGN COGNIZANCE BUAER
PROCUREMENT COGNIZANCE
STOCK NO.
R.D.B. IDENT. NO.

EQUIPMENT SUPPLIED DATA

QUANTITY PER EQUIPT	NAME AND NOMENCLATURE	OVERALL DIMENSIONS (inches)	WEIGHT (lbs.)
1	Radar Test Set TS-45/APM-3	7 X 8-1/2 X 11-1/4	22
*1	Pick-up Antenna AT-65/UP		
*1	RF Coupling UG-120/U		
*1	RF Coupling UG-121/U		
*1	RF Coupling UG-122/U		
*1	Test Meter Assembly TS-75/U		
†1	Crystal Rectifier		
†1	Plug and Cord Assembly CG-150/U		
†1	Cord with Spade Tips		
†1	Microammeter		
*1	Metal Box Carrying Case	7-1/16 X 7-3/16 X 10-1/4	7.5

* Part of Auxiliary Test kit TS-APM-3.

† Part of Test Meter Assembly TS-75/U.

21 June 1962

TEST SET TS-522/CRT-3

Cog Service: USAF FSN:

Functional Class: 10.1.11

USA

USN

USAF

TYPE CLASS:

Used by

Std

MANUFACTURER'S NAME/CODE NUMBER: John Meck Industries Inc., (39550).

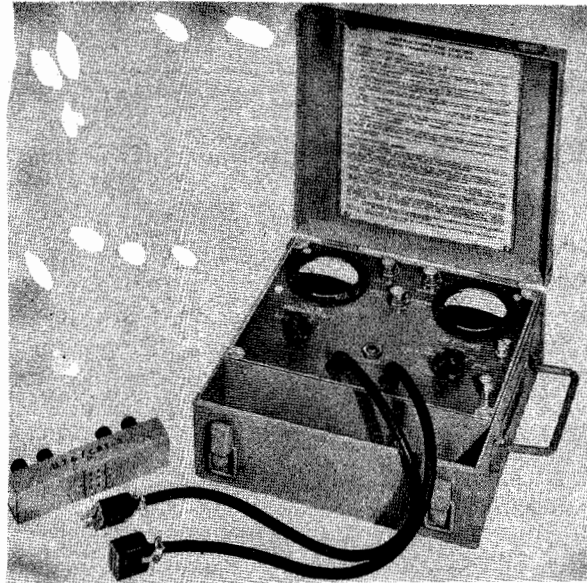

Test Set TS-522/CRT-3

FUNCTIONAL DESCRIPTION:

Test Set TS-522/CRT-3 is a portable instrument designed to check the condition and performance of Radio Transmitter T-74/CRT-3. It aids in the maintenance of this transmitter by helping to locate the cause of faulty operation.

No field changes in effect at time of preparation (4 April 1962).

TECHNICAL CHARACTERISTICS:

POWER REQUIREMENTS: 24 v dc, 0.3 amp; 320 v dc, 0.4 amp.

RELATION TO OTHER EQUIPMENT: None.

CONTRACTOR	LOCATION	CONTRACT OR ORDER NO.	APPROX. UNIT COST
Nilsson Electrical Laboratory Inc.	New York, New York		\$100.00
Yellow Springs Instrument Company, Inc.	Yellow Springs, Ohio	AF33(604)14621 AF33(604)13791	

January 1958

Test-Combination and Group

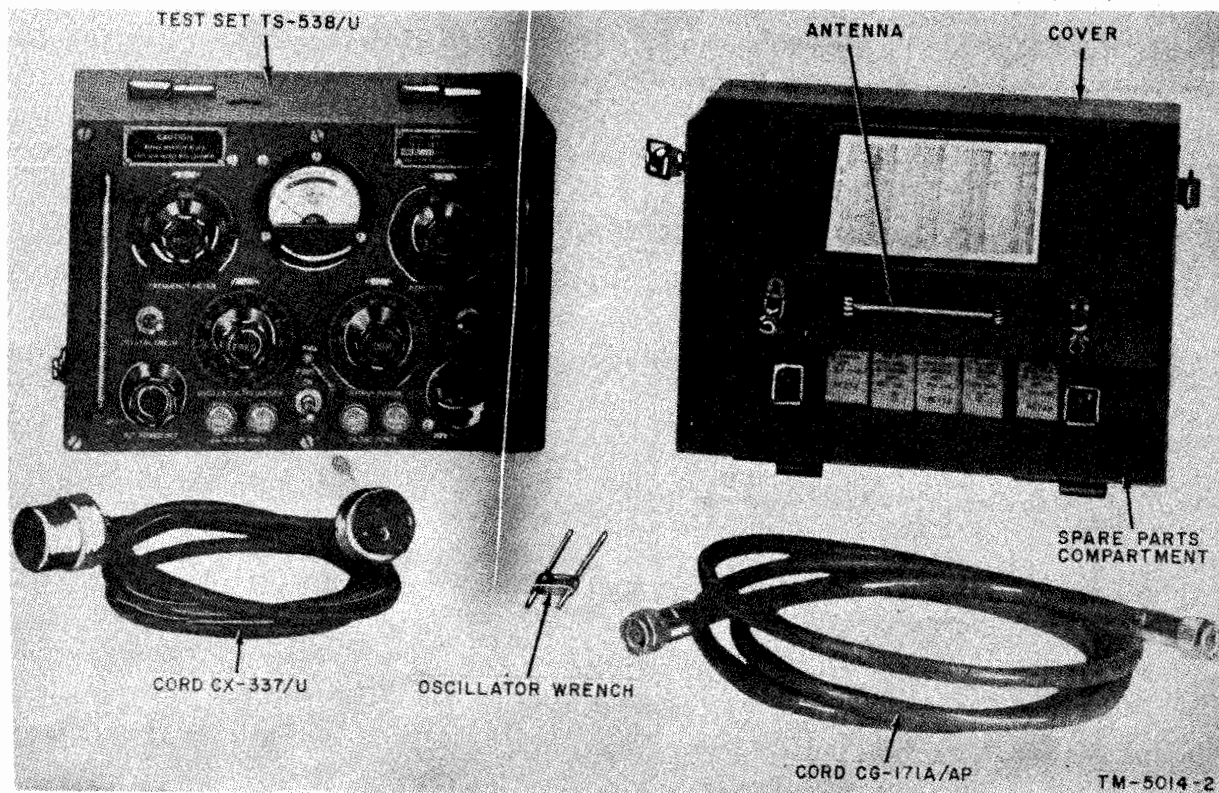
TEST SET**TS-538/U, 538A/U,
538B/U, 538C/U***Test Set TS-538/U, 538A/U, 538B/U, 538C/U***FUNCTIONAL DESCRIPTION**

The TS-538/U, TS-538A/U, TS-538B/U and TS-538C/U are designed primarily to measure the performance characteristics of the rawinsonde system that includes Radiosonde AN/AMT-4() and Rawin Set AN/GMD-1(). It is used to measure the frequency and power output of Radiosonde Transmitters T-304 ()/AMT-4A and T-435/AMT-4B and to measure the sensitivity, bandwidth, and tracking accuracy of Rawin Set AN/GMD-1(). It may also be used for similar purposes with any transmitter and/or receiver that operates within its frequency range.

The TS-538()/U series equipments are similar, differing only in some maintenance parts, frequency range, and power requirements.

No field changes in effect at time of preparation (25 July 1957).

ELECTRICAL AND MECHANICAL CHARACTERISTICS

FREQUENCY RANGE

TS-538/U, TS-538A/U, TS-538B/U: 1630 to 1730 mc.

TS-538C/U: 1615 to 1715 mc.

TYPE OUTPUT: CW or interrupted cw.

INTERRUPTION DATA

DURATION: 45 \pm 5 usec.

FREQUENCY: 5 to 200 cps.

VSWR: 1.45 to 1 max.

OUTPUT POWER: -107 to -20 dbm controlled by calibrated attenuator.

OUTPUT IMPEDANCE: 50 ohms.

ACCURACY

ATTENUATOR: \pm 1 dbm from -20 to -70 dbm, \pm 3 dbm from -70 to -107 dbm.FREQUENCY METER: \pm 2 mc.

POWER MONITOR SENSITIVITY: 150 to 250 mw at 10 in. from source.

POWER REQUIREMENTS: 117 \pm 12 v, 50 to 1600 cps, 50 to 65 cps only on Sig Corps Order No. 15903-PH-55.**MANUFACTURER'S OR CONTRACTOR'S DATA**

Allen D. Cardwell Electronics Production Corp, Plainville, Conn.

UNCLASSIFIED

4.10 TS-538/U: 1

January 1958

Test-Combination and Group

TEST SET**TS-538/U, 538A/U,
538B/U, 538C/U****TUBE AND/OR CRYSTAL COMPLEMENT**

TS-538/U, TS-538A/U, TS-538B/U and TS-538C/U.

(3) 6J6	(1) OB2
(1) 6X4	(1) 5675
Total Tubes: (6)	
(1) 1N23B	(1) 1N69
Total Crystals: (2)	

TYPE CLASSIFICATION DESIGN COGNIZANCE TASSA PROCUREMENT COGNIZANCE STOCK NO. R.D.B. IDENT. NO.

REFERENCE DATA AND LITERATURE

TM11-5014: Technical Manual for Test Sets

SHIPPING DATA

NUMBER OF BOXES	CONTENTS AND IDENTIFICATION	VOLUME (Cu.Ft.)	OVERALL DIMENSIONS (inches)	WEIGHT PACKED (lbs.)
1	Test Set TS-538/U or TS-538A/U or TS-538B/U or TS-538C/U	2.7	14-1/2 X 17-1/2 X 18-1/2	

EQUIPMENT SUPPLIED DATA

QUANTITY PER EQUIPT	NAME AND NOMENCLATURE	OVERALL DIMENSIONS (inches)	WEIGHT (lbs.)
1	Test Set TS-538/U or TS-538A/U or TS-538B/U or TS-538C/U including: (1) Antenna (1) Cord CX-337/U (1) Cord CG-171A/AP (1) Cover (1) Oscillator Wrench (1) Set of Running Spares	8 X 9-1/4 X 11-1/2 3/16 X 3-3/4 72 lg 84 lg 7-5/8 lg X 12 wd	23.5 0.1 0.5 1.2

OUTPUT METER

TS-585A/U

It is a direct reading meter which permits the operator to select 1 of 4 power ranges and 1 of 40 impedances.

No field changes in effect at time of preparation (6 February 1957).

RELATION TO OTHER EQUIPMENT

Same as and interchangeable with TS-585/U but with different maintenance items.

Equipment Required but not Supplied: (1) Set of test leads.

ELECTRICAL AND MECHANICAL CHARACTERISTICS

RANGE DATA

MILLIWATTS: 0.1 to 5000 in 4 steps.

DECIBELS: -10 to +37 dbm in 4 steps.

INPUT IMPEDANCES: 2.5, 3, 4, 5, 6, 8, 10, 12.5, 15, 20, 25, 30, 40, 50, 60, 80, 100, 125, 150, 200, 300, 400, 500, 600, 800, 1000, 1250, 1500, 2000, 2500, 3000, 4000, 5000, 6000, 8000, 10000, 12500, 15000, 20000 ohms.

ACCURACY (20 to 10000 cps)

POWER: ±5% at 11 db position.

IMPEDANCE: ±5%.

MANUFACTURER'S OR CONTRACTOR'S DATA

The Daven Co, Newark, N.J.

TUBE AND/OR CRYSTAL COMPLEMENT

No Electron Tubes.

REFERENCE DATA AND LITERATURE

TM11-5017: Technical Manual for Output Meter TS-585A/U.

TYPE CLASSIFICATION
 DESIGN COGNIZANCE TASSA
 PROCUREMENT COGNIZANCE
 STOCK NO.
 R.D.B. IDENT. NO.

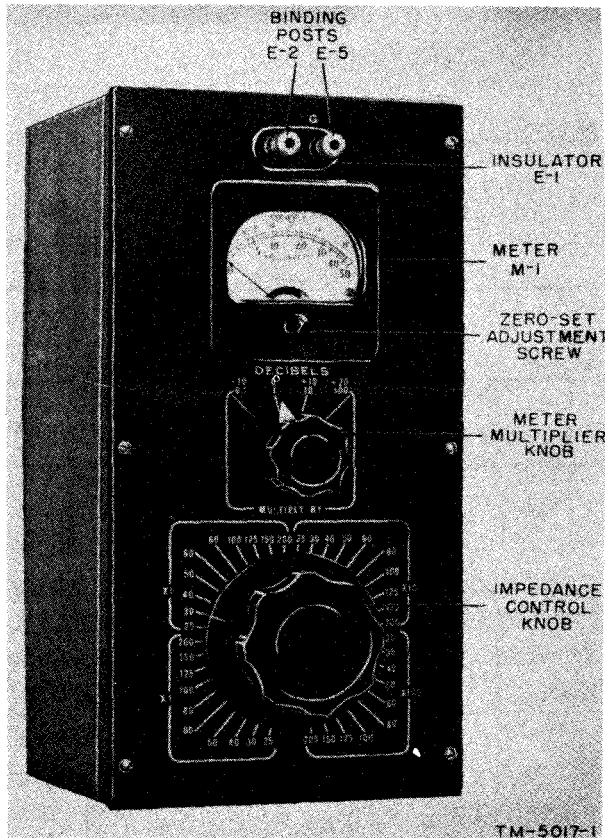

Output Meter TS-585A/U

FUNCTIONAL DESCRIPTION

The TS-585A/U is a portable instrument designed to measure power output of amplifiers, filters, oscillators, and similar equipment over a frequency range from 20 to 10000 cycles per second. It may also be used to determine the effect of load impedance on power delivered, and the characteristic impedance of transmission lines, audio amplifiers, filters, oscillators, and similar equipment. Standard radio-receiver tests such as noise pick-up level, bandwidth, selectivity, fidelity, and sensitivity may be made by using the decibel scale of the instrument.

SHIPPING DATA

NUMBER OF BOXES	CONTENTS AND IDENTIFICATION	VOLUME (Cu.Ft.)	OVERALL DIMENSIONS (inches)	WEIGHT PACKED (lbs.)
1	Output Meter TS-585A/U	1.6	12-1/4 X 12-1/4 X 18	30.5

Test-Combination and Group
TS-585A/U

OUTPUT METER

EQUIPMENT SUPPLIED DATA			
QUANTITY PER EQUIPT	NAME AND NOMENCLATURE	OVERALL DIMENSIONS (inches)	WEIGHT (lbs.)
1	Output Meter TS-585A/U	6 X 7 X 12	9

August 1957

Test-Combination and Group

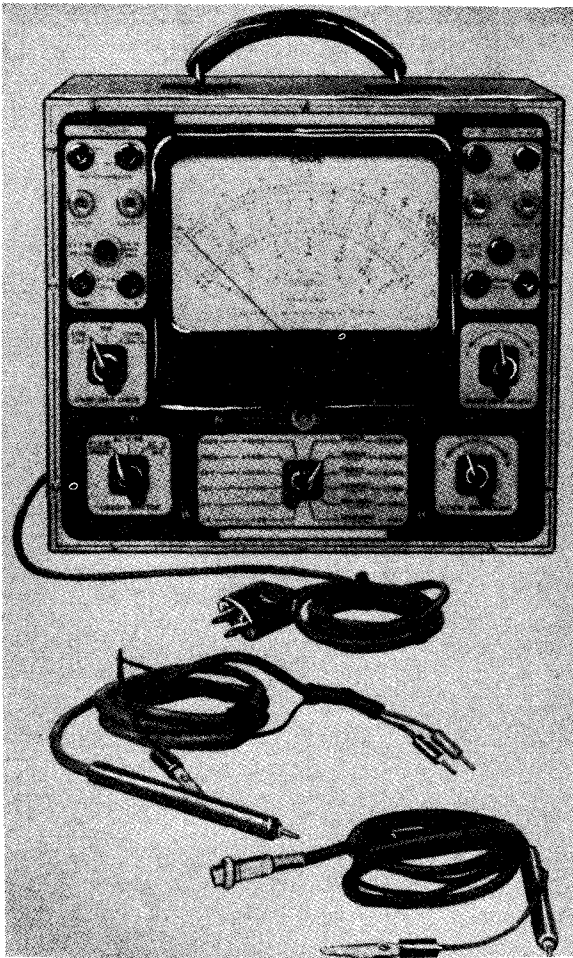
MULTIMETER**TS-616/U**

Multimeter TS-616/U

FUNCTIONAL DESCRIPTION

The TS-616/U is a portable combination test instrument which includes a vacuum tube voltmeter. It is used for measuring voltage,

current, and resistance, for circuit analysis, and for trouble shooting in electronic equipment.

No field changes in effect at time of preparation (5 February 1957).

RELATION TO OTHER EQUIPMENT

Similar to Precision Model 844-P.

ELECTRICAL AND MECHANICAL CHARACTERISTICS

RANGES: 0 to 6,000 v DC.
0 to 6,000 rms v, AC.
0 to 12 amp DC.
0 to 2000 meg.
-26 to +70 db.

ACCURACY

DC: $\pm 3\%$.
AC: $\pm 5\%$.

OPERATING POWER: 110 to 120 v, 50 to 60 cps.

TUBE AND/OR CRYSTAL COMPLEMENT

No Electron Tubes.

REFERENCE DATA AND LITERATURE

TM11-487H: Technical Manual for Test Equipment.

TYPE CLASSIFICATION
DESIGN COGNIZANCE TASSA
PROCUREMENT COGNIZANCE
STOCK NO.
R.D.B. IDENT. NO.

SHIPPING DATA

NUMBER OF BOXES	CONTENTS AND IDENTIFICATION	VOLUME (Cu.Ft.)	OVERALL DIMENSIONS (inches)	WEIGHT PACKED (lbs.)
1	Multimeter	3.14		60

EQUIPMENT SUPPLIED DATA

QUANTITY PER EQUIPT	NAME AND NOMENCLATURE	OVERALL DIMENSIONS (inches)	WEIGHT (lbs.)
1	Multimeter TS-616/U	7 X 11-3/4 X 12-1/4	17

UNCLASSIFIED
April 1958

Test-Combination and or Group

TELETYPEWRITER TEST SET

TS-652/GG

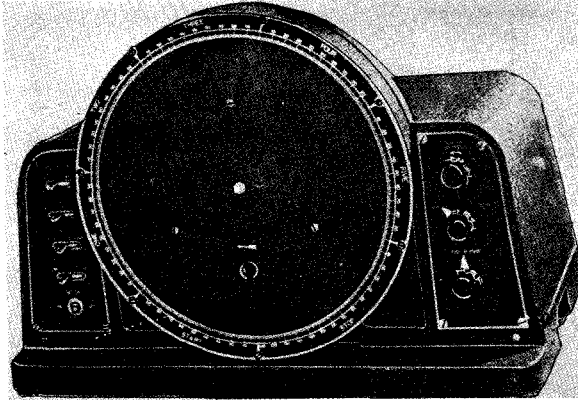

Teletypewriter Test TS-652/GG

FUNCTIONAL DESCRIPTION

The TS-652/GG provides signals for making performance tests of teletypewriter output, and provides a stroboscopic method of visually indicating the accuracy of received teletype signals. Test messages and signals may be either undistorted, or with a controlled degree of distortion.

No field changes in effect at time of preparation (2 May 1958).

RELATION TO OTHER EQUIPMENT

The TS-652/GG is similar to Distortion Test Set TS-383/GG, except that it uses a synchronous motor and does not include a speed indicator,

ELECTRICAL AND MECHANICAL CHARACTERISTICS

TEST SIGNALS: R, Y, T, O, M, V letters blank

unit marking pulse.
OPERATING SPEED: 368 operations per minute.
POWER SOURCE REQUIRED: 115 v, 60 cps.

MANUFACTURER'S OR CONTRACTOR'S DATA

Teletype Corp, Chicago, Illinois.
Contract NObsr-39217.
Approximate Cost: \$650.00 with equipment spares.

TUBE AND/OR CRYSTAL COMPLEMENT

No Electron Tubes or Crystals Used.

REFERENCE DATA AND LITERATURE

NAVSHIPS 91654: Technical Manual for Teletype Signal Distortion Test Set TS-652/GG.

TYPE CLASSIFICATION
DESIGN COGNIZANCE BUSHIPS
PROCUREMENT COGNIZANCE
STOCK NO.
R.D.B. IDENT. NO.

EQUIPMENT SUPPLIED DATA

QUANTITY PER EQUIPT	NAME AND NOMENCLATURE	OVERALL DIMENSIONS (inches)	WEIGHT (lbs.)
1	Teletypewriter Test Set TS-652/GG	13-1/2 X 14 X 19-1/2	125
1	Motor unit MU-4 and 96473 gears		

UNCLASSIFIED

4.10 TS-652/GG: 1

March 1957

TEST SET

TS-67/ARN-5

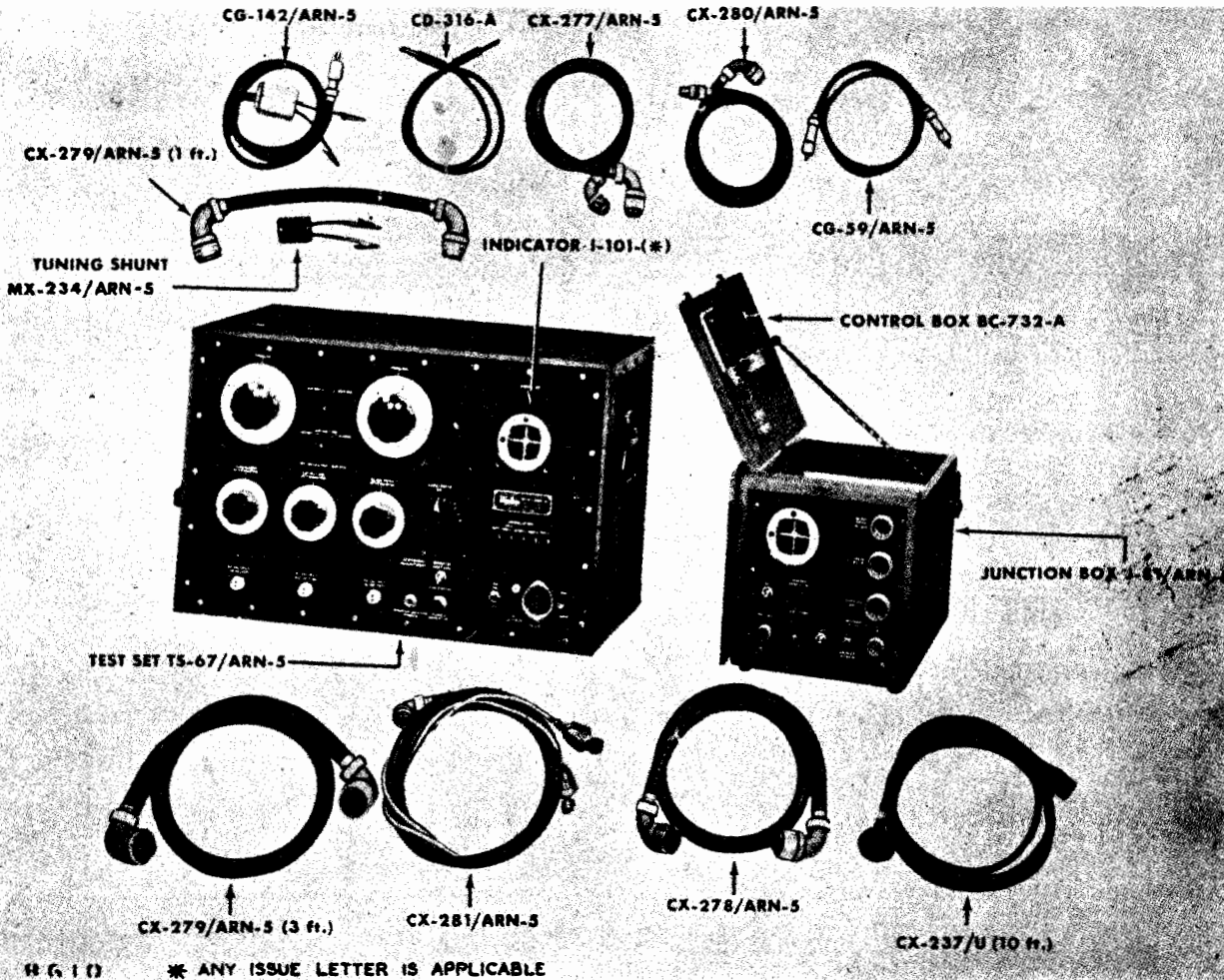

H G I I * ANY ISSUE LETTER IS APPLICABLE

Test Set TS-67/ARN-5

FUNCTIONAL DESCRIPTION

The TS-67/ARN-5 is used to simulate the frequency and radiation characteristics of the transmitters used with the Army Air Forces Instrument Approach System, for the purpose of testing and aligning the associated receivers. The equipment has provisions for connecting and testing Radio Receivers BC-733, R-47/HRN-5, R-57/ARN-5, and R-89/ARN-5.

No field changes in effect at time of preparation (22 August 1956).

ELECTRICAL AND MECHANICAL CHARACTERISTICS

OUTPUT FREQUENCY

- VARIABLE: 325 to 340 mc and 106 to 114 mc.
- CRYSTAL CONTROLLED: 6.9 mc and 20.7 mc.
- AUDIO: 90 cps and 1000 cps.
- MODULATED FREQUENCY: 30 cps.
- OUTPUT POWER: 1 to 100,000 uv.
- OPERATING POWER: 105 to 130 v, 50 to 60 cps, single ph, 77.5 to 118 W.

TUBE AND/OR CRYSTAL COMPLEMENT

- | | | |
|--------------|------------|-------------|
| (1) 6SJ7GT | (2) 6SN7GT | (1) 5Y3GT/G |
| (5) 6G6G | (3) 6AK5 | (1) 6X5GT/G |
| (2) 6SQ7GT/G | (2) 955 | (2) OD3 |
| | | (1) OA3 |

Total Tubes: (20)

TS-67/ARN-5

TEST SET

March 1957

REFERENCE DATA AND LITERATURE

AN 08-35TS67-2: Technical Manual for Test
Set TS-67/ARN-5.

TYPE CLASSIFICATION DESIGN COGNIZANCE USAF PROCUREMENT COGNIZANCE STOCK NO. R.D.B. IDENT. NO.

EQUIPMENT SUPPLIED DATA

QUANTITY PER EQUIPT	NAME AND NOMENCLATURE	OVERALL DIMENSIONS (inches)	WEIGHT (lbs.)
1	Test Set TS-67/ARN-5	15-1/16 x 15-1/2 x 23-5/8	107.0
1	Indicator I-101-C		
1	Junction Box J-81/ARN-5 consists of:	9-15/16 x 10-5/8 x 15-11/16	20.0
2	Cord CG-59/ARN-5	42 lg	
1	Cord CG-142/ARN-5	42 lg	
1	Cord CX-237/U	120 lg	
1	Tuning Shunt MX-234/ARN-5		
1	Indicator I-101-C or D		
1	Mounting FT-292-A	9/32 x 3-3/32 x 4-1/32	
1	Control Box BC-732-A	2-5/8 x 3-9/32 x 4-1/32	
1	Cord CX-277/ARN-5	36 lg	
1	Cord CX-278/ARN-5	36 lg	
1	Cord CX-279/ARN-5	12 lg	
1	Cord CX-279/ARN-5	36 lg	
1	Cord CX-280/ARN-5	36 lg	
1	Cord CX281/ARN-5	72 lg	
1	Cord CD-316-A	36 lg	

17 May 1962
Cog Service:

FSN: 6625-618-0088

PULSE ANALYZER-SIGNAL GENERATOR TS-890A/URN-3
Functional Class:

USA

USN

USAF

TYPE CLASS:

MANUFACTURER'S NAME/CODE NUMBER: Federal Telephone and Radio Co.

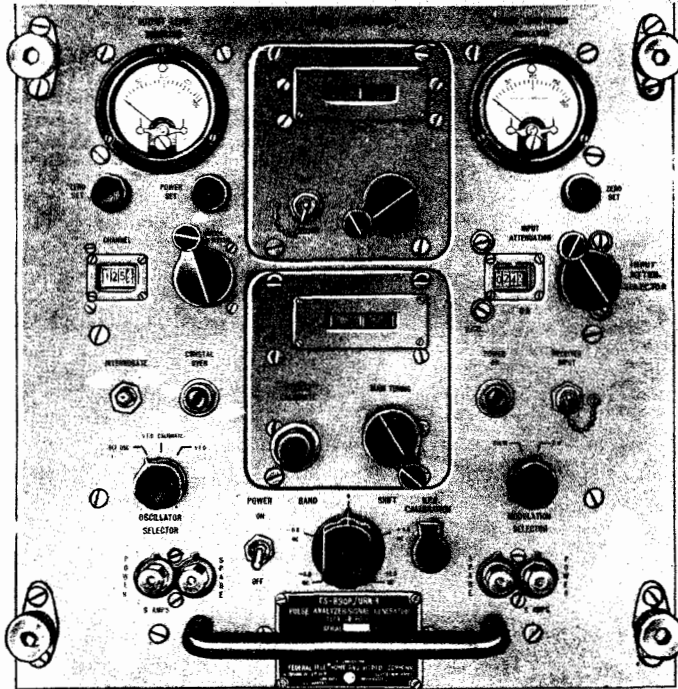

Pulse Analyzer-Signal Generator TS-890A/URN-3

FUNCTIONAL DESCRIPTION:

Pulse Analyzer-Signal Generator TS-890A/URN-3 is designed specifically for use as a test equipment for Radio Sets AN/SRN-6, AN/GRN-9, AN/GRN-9A, AN/GRN-9B and AN/GRN-9C. Together with three other companion units, it is to be mounted in Power Supply Assembly OA-1535/SRN-6, OA-1536/GRN-9, OA-1537/GRN-9A, OA-1804A/GRN-9B, or OA-1916/GRN-9C. An additional companion unit (SA-420/URN-3) mounts outside of this cabinet. When used with these four units, the TS-890A/URN-3 permits a rapid check of important operating characteristics of the Radio Sets.

No field changes in effect at time of preparation (26 July 1961).

TECHNICAL CHARACTERISTICS:

FREQUENCY RANGE

SIGNAL GENERATOR OUTPUT: 1025 to 1150 mc, 126 channels; basic frequency source is continuously tunable vfo in 39.51 to 41.04 range.

TS-890A/URN-3 PULSE ANALYZER-SIGNAL GENERATOR

PULSE ANALYZER INPUT: 962 to 1024 mc and 1151 to 1213 mc.
PULSE ANALYZER SPECTRAL ACCEPTANCE CHARACTERISTICS
PORM 0.8 MC OFF CHANNEL: 60 db down.
PORM 2.0 MC OFF CHANNEL: 65 db down.
TYPE OF FREQUENCY CONTROL: Crystal and stabilized variable-frequency oscillators.
TYPE OF EMISSION: CW(A1) or Pulse(P0).
SIGNAL GENERATOR MODULATION PULSE CHARACTERISTICS
PRF: 40 to 5,000 pulse pairs per second.
VOLTAGE AND SOURCE IMPEDANCE: 250 v, 650 ohms.
SIGNAL GENERATOR POWER OUTPUT
CW: 0.5 v.
PEAK PULSE: 0.5 v.
PULSE ANALYZER INPUT POWER RANGE: 1 mw at 3,600 pps.
POWER REQUIREMENTS: 120 v porm 10%, 60 cyc porm 2%, single ph, 380 W, PF 90%.

RELATION TO OTHER EQUIPMENT: None.

EQUIPMENT REQUIRED BUT NOT SUPPLIED:

(1) Radio Set AN/SRN-6, AN/GRN-9, -9A, -9B or -9C; (1) Pulse-Sweep Generator SG-121A/URN-3;
(1) Power Meter-Pulse Counter TS-891/URN-3; (1) Oscilloscope OS-54/URN-3; (1) Switch-Test
Adapter SA-420/URN-3; (1) Interconnecting Harness; (1) Alignment Tool FTL dwg A2053110.

MAJOR COMPONENTS

QTY	ITEM	STOCK NUMBERS	DIMENSIONS (INCHES)	WEIGHT (LBS)
1	Pulse Analyzer-Signal Generator TS-890A/URN-3		13-1/2 x 14-5/8 x 24	95
2	Technical Manual NAVSHIPS 93231		1/2 x 9 x 11-1/2	2
1	Set Maintenance Parts			

REFERENCE DATA AND LITERATURE:

NAVSHIPS 93231: Technical Manual for Pulse Analyzer-Signal Generator TS-890A/URN-3.

TUBE, CRYSTAL AND/OR SEMI-CONDUCTOR DATA:

TUBES: (1) 0B2WA (3) 2C39A (2) 5R4WGB (1) 6AN5WA (10) 5654 (3) 5656 (6) 5670
(1) 5751 (1) 6080WA (1) 6336

CRYSTALS: (7) CR-23/U (1) CR-32/U

SEMI-CONDUCTORS: (2) 1N23B (1) 1N25 (1) 1N198

PULSE ANALYZER-SIGNAL GENERATOR TS-890A/URN-3

SHIPPING DATA

PKGS	VOLUME (CU FT)	WEIGHT (LBS)
1	10.3	140
1	3.3	65

PROCUREMENT DATA

PROCURING SERVICE: DESIGN COG: USN, BuShips
SPEC &/OR DWG: MIL-R-19851(SHIPS), Amend 2

CONTRACTOR	LOCATION	CONTRACT OR ORDER NO.	APPROX. UNIT COST
Federal Telephone and Radio Co.	Clifton, N. J.	N0bsr-75066, 13 December 1957	\$3,265.84

UNCLASSIFIED

August 1957

Test-Combination and Group

POWER METER-PULSE COUNTER AND SWITCH-TEST ADAPTER

TS-891/URN-3
SA-420/URN-3

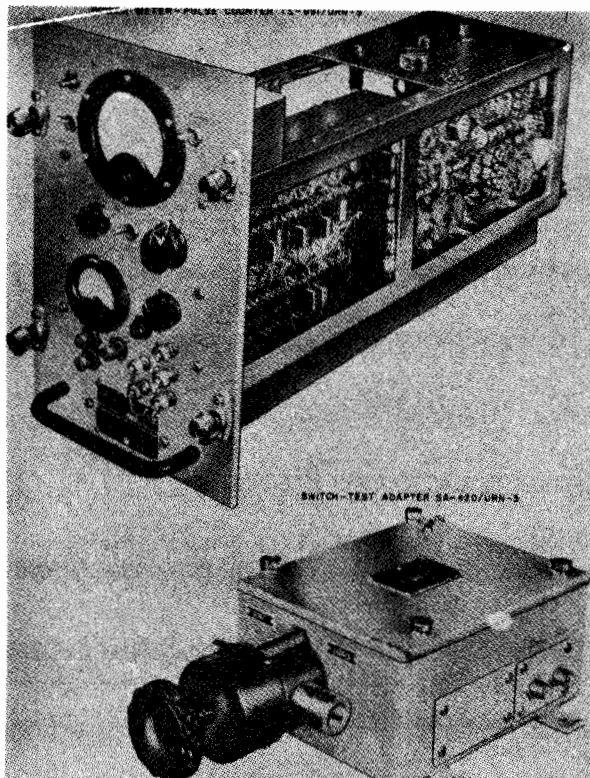

Power Meter-Pulse Counter
and Switch-Test Adapter
TS-891/URN-3 SA-420/URN-3

FUNCTIONAL DESCRIPTION

The TS-891/URN-3 and SA-420/URN-3 are part of the special test equipment for Radio Set AN/URN-3 which is a radio beacon designed for shipboard or ground installation, and is part of a complete air navigation system.

The TS-891/URN-3 is a panel mounted unit which measures the peak RF power output of the AN/URN-3 in its frequency range of 960 to 1215 megacycles, the average repetition rate of all pulse sources in the AN/URN-3 and its test equipment over a range of 80 to 8000 pulses per second, and provides a Function Switch to perform certain necessary inter-unit signal switching operations.

The SA-420/URN-3 is designed for wall or bulkhead mounting and provides a manually operated coaxial switch for connecting the transmitter RF output to either the transmitting antenna or a dummy load, a directional coupler and a crystal detector which makes a detected sample of RF available to the power

meter-pulse counter for peak power measurements, and a voltage probe and a crystal detector which makes a detected sample of RF available to the Radio Frequency Monitor MX-1627/URN-3 for power monitoring purposes.

No field changes in effect at time of preparation (7 December 1956).

RELATION TO OTHER EQUIPMENT

Equipment Required but not Supplied: (1) Radio Set AN/URN-3, (1) Pulse-Sweep Generator SG-121A/URN-3, (1) Pulse Analyzer-Signal Generator TS-890/URN-3, (1) Oscilloscope OS-54/URN-3, (1) Radio Frequency Monitor MX-1627/URN-3.

ELECTRICAL AND MECHANICAL CHARACTERISTICS

POWER METER-PULSE COUNTER PULSE COUNTER DATA

RANGE: 80 to 8000 pps repetition rate.

ACCURACY: $\pm 2.0\%$ from 2600 to 3100 pps at steady line voltage and ambient temperatures when calibrated at 2800 pps. $\pm 5\%$ for other pulse rates and service conditions.

SENSITIVITY: Records all pulses with peak amplitude exceeding 2 v, with 0.5 to 5 usec width.

RESOLUTION: Records all pulses spaced 8 usec min apart, provided signal level between pulses falls below 0.5 v for 1 usec min.

STABILITY: $\pm 3\%$ for fixed pulse repetition rate from 2 to 60 v peak amplitude variations, and 0.5 to 6 usec pulse width at 50% amplitude.

INPUT IMPEDANCES: 100,000 ohms min shunted by 50 uuf max for all input impedances.

RCVR TEST INPUT: 2.5 v peak, positive polarity, 3 to 4 usec at 50% points.

VIDEO TEST INPUT: 1.4 v peak, positive polarity, 1.5 usec at 50% points.

MOD SYNC INPUT: 20 v peak, positive polarity, triangular pulse, 3 to 4 usec at 10% up-from-base-line points.

POWER METER DATA

FULL SCALE READING: 10 kw peak RF.

ACCURACY: $\pm 3\%$ of full scale reading.

POWER REQUIREMENTS: 120 v $\pm 10\%$, 60 cps $\pm 5\%$, single ph, 100 W.

TEMPERATURE RANGE: Operates within aforementioned operational limits in 0 to 40 deg C (+32 to +104 deg F) ambient and within twice the limits in the ambient ranges of -28 to 0 deg C (-18 to +32 deg F) and +40 to +50 deg C (+104 to +122 deg F). Remains operative in -54 to +75 deg C (-65 to +167 deg

UNCLASSIFIED

4.10 TS-891/URN-3: 1

August 1957

Test-Combination and Group

TS-891/URN-3 POWER METER-PULSE COUNTER AND SA-420/URN-3 SWITCH-TEST ADAPTER

F) but not necessarily within the operational limits.

SWITCH-TEST ADAPTER

FREQUENCY RANGE: 960 to 1215 mc.
OVERALL VSWR: 1.4 to 1 max.
OVERALL INSERTION LOSS: 0.5 db at 1000 mc.

CHARACTERISTIC IMPEDANCE: 50 ohms nqm.
AVERAGE RF POWER RATING: 150 W.
PEAK RF POWER RATING: 7.5 kw.
DC VOLTAGE RATING: 1000 v.
AMBIENT TEMPERATURE RANGE: -54 to +75 deg C (-65 to +167 deg F).
AMBIENT HUMIDITY RANGE: 0 to 95%.
COAXIAL SWITCH DATA
VSWR: 1.3 to 1 max.
INTERLOCK SWITCH RATING: 120 v AC, 15 amps.

DIRECTIONAL COUPLER DATA

DIRECTIVITY: 12 db min over frequency range.

COUPLING: -50 \pm 0.25 db at 987.5 mc.

COUPLING VARIATION: 1 db from 960 to 1215 mc.

VOLTAGE PROBE ATTENUATION: Variable from 50 db +5 db, -0 to 70 db, +5 db, -0 db over frequency range.

MANUFACTURER'S OR CONTRACTOR'S DATA

Olympic Radio and Television, Inc., Long

Island City, N.Y.

Contract NObsr 64757, dated 31 May 1955.

Approximate Cost: \$782.00 with equipment spares.

TUBE AND/OR CRYSTAL COMPLEMENT

TS-891/URN-3

(1) 0A2WA	(1) 5Y3WGTA	(1) 6AU6WA
(1) 6CD6G	(1) 6X4W	(2) 12AT7WA
(2) 5670	(1) 5725	(1) 5726
(1) 5814A	(1) 6080WA	

Total Tubes: (13)

REFERENCE DATA AND LITERATURE

NAVSHIPS 92809: Technical Manual for Power Meter-Pulse Counter TS-891/URN-3 and Switch-Test Adapter SA-420/URN-3.

TYPE CLASSIFICATION
DESIGN COGNIZANCE BUSHIPS
PROCUREMENT COGNIZANCE MIL-R-18428A(SHIPS)
STOCK NO.
R.D.B. IDENT. NO.

SHIPPING DATA

NUMBER OF BOXES	CONTENTS AND IDENTIFICATION	VOLUME (Cu.Ft.)	OVERALL DIMENSIONS (inches)	WEIGHT PACKED (lbs.)
1	Power Meter-Pulse Counter TS-891/URN-3	3	11 X 16 X 29	48.5
1	Switch-Test Adapter SA-420/URN-3	0.95	8 X 11-3/4 X 17-1/2	22

EQUIPMENT SUPPLIED DATA

QUANTITY PER EQUIPT	NAME AND NOMENCLATURE	OVERALL DIMENSIONS (inches)	WEIGHT (lbs.)
1	Power-Meter-Pulse Counter TS-891/URN-3	9-1/2 X 14-13/32 X 26-3/4	31.5
1	Switch-Test Adapter SA-420/URN-3	5-7/8 X 9-3/4 X 15-5/8	15
2	Technical Manual NAVSHIPS 92809	1/4 X 8-1/2 X 11	
1	Power Meter-Pulse Counter Maintenance Parts Kits		
1	Switch-Test Adapter Maintenance Parts Kit		

UNCLASSIFIED

June 1957

Test-Combination And Group

TS-96/TPS-1 (I-153-A)

ANALYZER

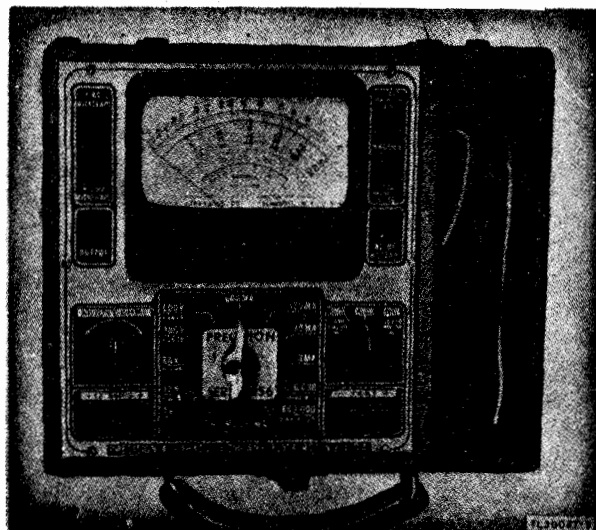

Analyzer TS-96/TPS-1(I-153-A)

FUNCTIONAL DESCRIPTION

The TS-96/TPS-1, is designed to cover a wide range of voltage, current, and resistance measurements.

No field changes in effect at time of preparation (26 September 1956),

RELATION TO OTHER EQUIPMENT

Same as Precision Model 856.

ELECTRICAL AND MECHANICAL CHARACTERISTICS

SENSITIVITY: 1000 ohms per v for AC and 1000, or 20,000 ohms for DC.

VOLTAGE RANGES: 0 to 3, 12, 60, 300, 600, 1200, and 6000 v for AC and DC.

CURRENT RANGES (DC): 0 to 60 and 300 ua, 0 to 3, 30, 120 and 600 ma, 0 to 12 amp.

RESISTANCE MEASUREMENTS: 0 to 6000, 600,000, and 60 meg.

DB MEASUREMENT: -12 to +70 db.

OPERATING POWER: 1-1/2 v battery and 22-1/2 v battery.

TUBE AND/OR CRYSTAL COMPLEMENT

No Electron Tubes.

REFERENCE DATA AND LITERATURE

TM-11-1200: Technical Manual for Radar Test Set.

TYPE CLASSIFICATION
DESIGN COGNIZANCE BUSHIPS
PROCUREMENT COGNIZANCE
STOCK NO.
R.D.B. IDENT. NO.

EQUIPMENT SUPPLIED DATA

QUANTITY PER EQUIPT	NAME AND NOMENCLATURE	OVERALL DIMENSIONS (inches)	WEIGHT (lbs.)
1	Analyzer TS-96/TPS-1 (I-153-A)	6 X 9 X 10	7
2	Test Leads		

UNCLASSIFIED

28 February 1963

Cog Service: USN

FSN:

RADAR TEST SET X-BAND

Functional Class: 10.1.3

USA

USN

USAF

TYPE CLASS:

Used by

MANUFACTURER'S NAME/CODE NUMBER: Sperry Microwave Electronics Co.,
Div. Sperry Rand Corp., (06424).

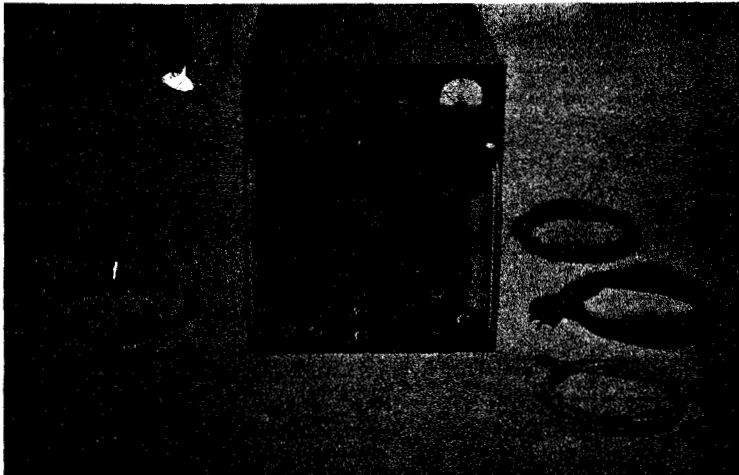

1. X-Band Radar Test Set
2. R-F Cable
3. Power Cable
4. Video Cable
5. Fuses

Radar Test Set X-Band

FUNCTIONAL DESCRIPTION:

Radar Test Set is a portable, self-contained, combination test set designed for use in testing and adjusting radar and beacon systems operating in the frequency range of 7500 to 11000 mc. It has been transistorized to the greatest extent possible in the interests of compactness and reliability. The test set may be used for the measurement of power and frequency, and also serves as a signal generator over its frequency range. Am, fm and cw operation is available using internal circuits, and the test set may also be externally pulse modulated where desired. Power output available is between 20 and 150 mw, depending upon frequency.

No field changes in effect at time of preparation (22 January 1963).

X-BAND RADAR TEST SET

TECHNICAL CHARACTERISTICS:

FREQUENCY RANGE: 7500 to 11000 mc.

FREQUENCY METER

RANGE: 7.5 to 11 k mc.

ACCURACY AT 25 DEG C (DIRECT READING): Porm 0.01% at 9310 mc, porm 0.025% o/a.

POWER OUTPUT

HIGH (UNCALIBRATED): Greater than M10 dbm.

LOW (CALIBRATED): 0 to M100 dbm

ACCURACY AT 25 DEG C (WITH CORRECTION CHART): Porm 2 db (0 to M50 dbm), porm 3 db (M50 to M100 dbm).

SIGNAL GENERATOR

CW OPERATION: Porm 2 db max power variation for 100 mc internal.

MODULATION

AM: 1000 cps square wave porm 1%; 100 v P10% amplitude (on BW0 grid).

FM: 0 to 20 mc/usec min deviation.

PHASE (DELAY): 4 to 50 usec after triggering.

TRIGGER

INTERNAL: 100 to 4000 pps.

EXTERNAL: Porm 10 to porm 50 v; 0.2 to 10.0 usec; 100 to 4000 pps.

DETECTED RF PULSE: 100 to 4000 pps.

EXTERNAL PULSE: 0.3 to 50 usec pulse width; P100 v porm 10% amplitude; 100 to 4000 pps repetition rate.

SYNC OUTPUT: Porm 15 v amplitude 100 to 4000 pps.

POWER INPUT

ACCURACY AT 25 DEG C (WITH CALIBRATION CHART): P5 to P30 dbm porm 1 db.

LEVEL SET ATTENUATION: 10 db (uncalibrated).

POWER REQUIREMENTS: 115 v porm 10% ac, 50 to 1000 cyc, 2.2 amp (operating).

POWER FACTOR: Approx. 0.96.

RELATION TO OTHER EQUIPMENT: None.

EQUIPMENT REQUIRED BUT NOT SUPPLIED:

(1) Pulse Generator AN/UPM-55.

MAJOR COMPONENTS

QTY	ITEM	STOCK NUMBERS	DIMENSIONS (INCHES)	WEIGHT (LBS)
1	Radar Test Set, X-Band		11 x 13 x 18-1/8	70
1	Power Cable CX-3135/U		1-1/2 dia x 96	
1	RF Cable		1 dia x 60	4.5
4	Video Cable CG-1433/U		1 dia x 96	3

REFERENCE DATA AND LITERATURE:

NAVSHIPS 93815: Technical Manual for X-Band Radar Test Set.

4.10 X-Band: 2

RADAR TEST SET X-BAND

TUBE, CRYSTAL AND/OR SEMI-CONDUCTOR DATA:

TUBES: (3) 0A2 (2) 0B2 (3) 6BG6GA (1) 6AU6

CRYSTALS: None used.

SEMI-CONDUCTORS: (4) 1N488A (1) 2N497 (1) 1N3007A (1) 1N3000 (4) M500
(4) MU46WH (1) QKB-870 (3) 2N167 (11) 1N277 (4) 1N464 (1) 1N753
(6) 1N752 (1) 1N139 (6) 2N332 (1) 2N1041 (1) 2N341A (1) 2N491
(1) 2N333 (1) 2N525 (1) 651C5 (1) 2N696 (1) 2N1047 (2) 2N338
(1) 2N340

SHIPPING DATA

PKGS	VOLUME (CU FT)	WEIGHT (LBS)
1	7.65	

PROCUREMENT DATA

PROCURING SERVICE: USN
SPEC &/OR DWG: SHIPS-T-2646

DESIGN COG: USN, BuShips

CONTRACTOR	LOCATION	CONTRACT OR ORDER NO.	APPROX. UNIT COST
Sperry Microwave Electronics Co., Div. Sperry Rand Corp.	Clearwater, Florida	N0bsr-72725	

UNCLASSIFIED

June 1957

Test-Combination And Group

TEST METER UNIT

1410

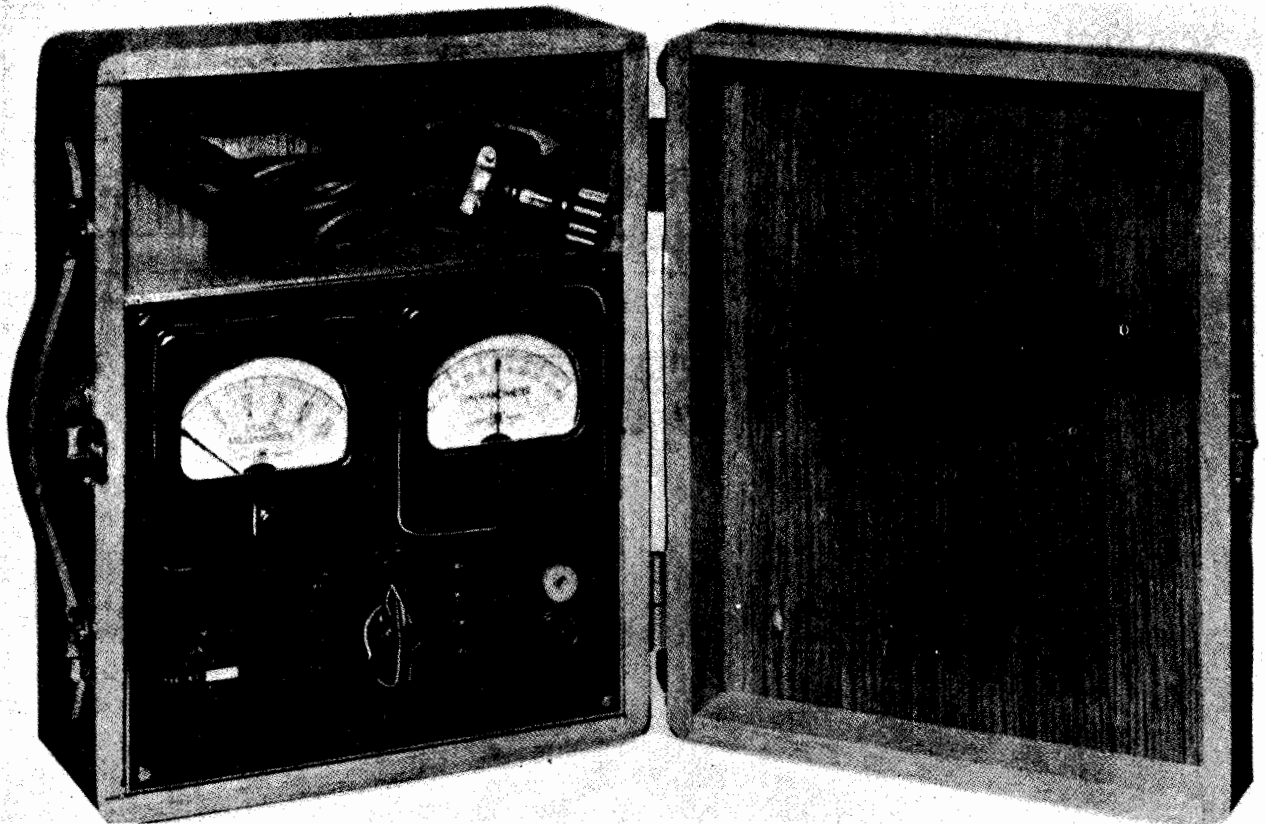

Test Meter Unit 1410

FUNCTIONAL DESCRIPTION

The 1410 unit combines in a portable case all necessary metering facilities for field checking or installation of the MN equipment. Two meters are used. One is a multiscale meter giving the following ranges: 0 to 1 ma, 0 to 2.5 ma, 0 to 50 ma, 0 to 25 v and 0 to 250 v DC. It is used to measure grid and plate currents in the transmitter as well as limiter grid currents in the receiver.

The second meter is center-zero galvanometer. This meter is used for adjusting the receiver discriminator circuit. The test meter is so arranged that all meter readings may be taken on the radio transmitter-receiver NT-43018 by means of a single multi-conductor test cord and plug attached to the meter unit.

No field changes in effect at time of preparation (27 Sept 1956).

ELECTRICAL AND MECHANICAL CHARACTERISTICS

MULTISCALE METER

RANGES: 0 to 1 ma, 0 to 2.5 ma, 0 to 50 ma, 0 to 25 v, 0 to 250 v DC.

GALVANOMETER

RANGE: 50 to 0 to 50.

FULL SCALE DEFLECTION: 75 ua.

MANUFACTURER'S OR CONTRACTOR'S DATA

Fred M. Link, N.Y., N.Y.

Contract: NXa-3834, dated 20 Apr 1942

TUBE AND/OR CRYSTAL COMPLEMENT

No Electron Tubes.

UNCLASSIFIED

4.10 1410: 1

Test-Combination And Group

June 1957

1410

TEST METER UNIT

REFERENCE DATA AND LITERATURE

Technical Manual for RADIO RECEIVING AND
TRANSMITTING EQUIPMENT MN.

TYPE CLASSIFICATION DESIGN COGNIZANCE PROCUREMENT COGNIZANCE STOCK NO. R.D.B. IDENT. NO.

EQUIPMENT SUPPLIED DATA

QUANTITY PER EQUIPT	NAME AND NOMENCLATURE	OVERALL DIMENSIONS (inches)	WEIGHT (lbs.)
1	Test Meter Unit 1410		

MULTIMETER

22193

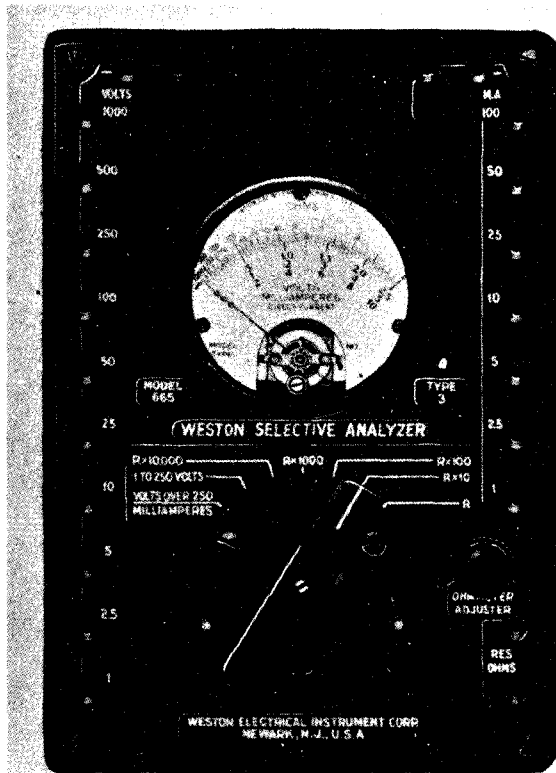

Multimeter 22193

ELECTRICAL AND MECHANICAL CHARACTERISTICS

RANGE: 0 to 1000 v in 10 steps.
 0 to 100 ma in 7 steps.
 0 to 10 meg in 5 steps.
 ACCURACY: $\pm 2.5\%$.
 SENSITIVITY: 50 ua.
 OPERATING POWER: 15 v DC battery.

MANUFACTURER'S OR CONTRACTOR'S DATA

Weston Electrical Instrument Corp, Newark,
 NY
 Contract NXsr-41024

TUBE AND/OR CRYSTAL COMPLEMENT

No Electron Tubes.

REFERENCE DATA AND LITERATURE

Technical Manual for RADIO RECEIVER ANALYZING
 EQUIPMENT OE-12.

FUNCTIONAL DESCRIPTION

The NT-22193 is a multi-purpose DC meter suitable for the measurement of voltage, current and resistance.

No field changes in effect at time of preparation (27 Sept 1956).

TYPE CLASSIFICATION
 DESIGN COGNIZANCE BUSHIPS
 PROCUREMENT COGNIZANCE
 STOCK NO.
 R.D.B. IDENT. NO.

EQUIPMENT SUPPLIED DATA

QUANTITY PER EQUIPT	NAME AND NOMENCLATURE	OVERALL DIMENSIONS (inches)	WEIGHT (lbs.)
1	Multimeter NT-22193	3-7/8 x 5-1/2 x 8-1/4	5.25
2	Test Leads		

UNCLASSIFIED

March 1957

Test Combination and Group
22195

POWER LEVEL INDICATOR

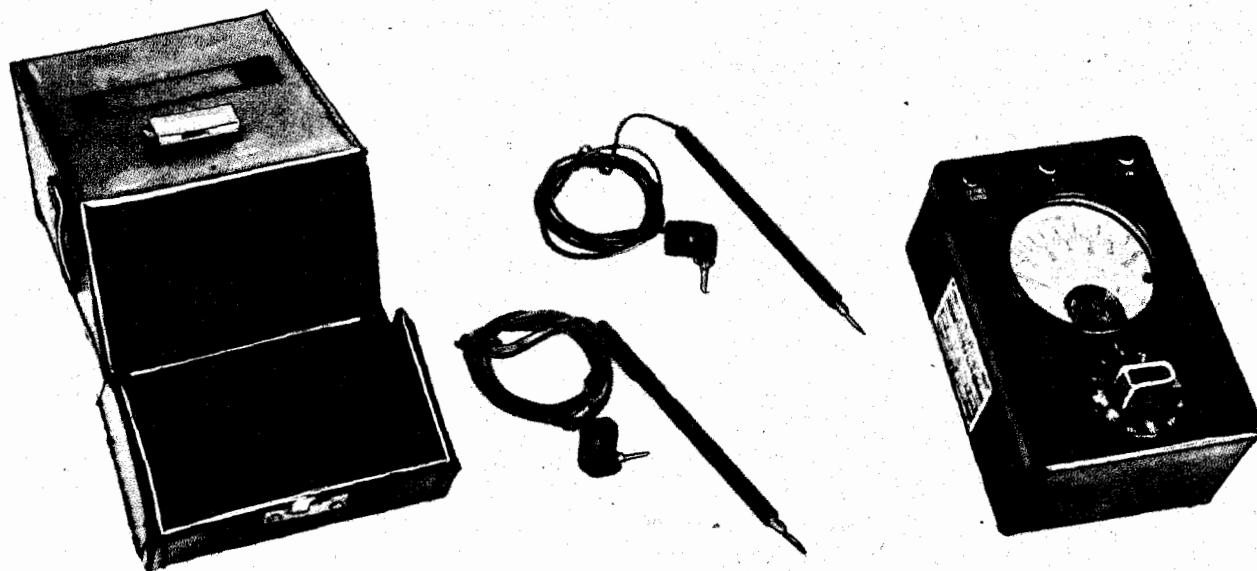

Power Level Indicator

FUNCTIONAL DESCRIPTION

The 22195 is a portable, self-contained rectifier type voltmeter providing readings in decibels and volts for power measurements in all types of speech equipment and radio receivers. It is adjusted for a zero level of 6 mw in a 500 ohm line. The instrument has a constant input impedance of 20,000 ohms on all ranges, as well as a constant impedance across the meter terminals, resulting in uniform accuracy on all decibel ranges.

No field changes in effect at time of preparation (17 September 1956).

ELECTRICAL AND MECHANICAL CHARACTERISTICS

RANGE: 0 to 1.5, 6, 15, 60, 150 v AC; -8
-4, 0, 4, 8, 12, 16, 20, 24, 32 db.
ACCURACY: $\pm 5\%$.
SENSITIVITY: 2.667 ohms per v.
INPUT IMPEDANCE: 20,000 ohms.

TUBE AND/OR CRYSTAL COMPLEMENT

No Electron Tubes.

REFERENCE DATA AND LITERATURE

Technical Manual for Marine Corp Material
Vol. I.

TYPE CLASSIFICATION
DESIGN COGNIZANCE BUSHIPS
PROCUREMENT COGNIZANCE
STOCK NO.
R.D.B. IDENT. NO.

SHIPPING DATA

NUMBER OF BOXES	CONTENTS AND IDENTIFICATION	VOLUME (Cu.Ft.)	OVERALL DIMENSIONS (inches)	WEIGHT PACKED (lbs.)
1	Power Level Indicator 22195	0.13		3.5

UNCLASSIFIED

4.10 22195: 1

Test Combination and Group

March 1957

22195

POWER LEVEL INDICATOR

EQUIPMENT SUPPLIED DATA

QUANTITY PER EQUIPT	NAME AND NOMENCLATURE	OVERALL DIMENSIONS (inches)	WEIGHT (lbs.)
1	Power Level Indicator 22195 consist of:	3-1/8 X 3-45/64 X 5-33/64	2.5
2	Test Lead	48 lg	
1	Case		

UNCLASSIFIED

April 1958

Test-Power Measuring

VOLT-OHM MILLIAMMETER

60046

FUNCTIONAL DESCRIPTION

The Navy Type 60046 is a portable self-contained instrument essentially designed to measure AC and DC voltages, DC milliamperes, output in decibels, and resistance. It is the Precision Apparatus Co. Series 832-A.

No field changes in effect at time of preparation (7 May 1958).

ELECTRICAL AND MECHANICAL CHARACTERISTICS

OPERATING FEATURES

DC RANGE: 0 to 1200 v at 1000 ohms per v.
AC RANGE: 0 to 2400 v at 500 ohms per v.
DC MILLIAMPERES RANGE: 0 to 1200.
RESISTANCE RANGE: 0 to 5 meg.
DECIBELS RANGE: -10 to +62 db.
ACCURACY: 2% on DC, and 3% on AC.
POWER SOURCE REQUIRED: 2 batteries (1.5 v), Eveready No. 935 or equivalent; 27 v DC supply necessary in order to use the meg resistance scale.

MANUFACTURER'S OR CONTRACTOR'S DATA

Precision Apparatus Co; Elmhurst, L. I., N.Y.

Contract NXs-12023; dated 27 August 1942.

Approximate Cost: \$35.00 with equipment spares.

TUBE AND/OR CRYSTAL COMPLEMENT

No Electron Tubes or Crystals used.

REFERENCE DATA AND LITERATURE

NAVSHIPS 95432: Technical Manual for Navy Type 60046 Volt-Ohm-Milliammeter.

TYPE CLASSIFICATION
DESIGN COGNIZANCE BUSHIPS
PROCUREMENT COGNIZANCE
STOCK NO.
R.D.B. IDENT. NO.

EQUIPMENT SUPPLIED DATA

QUANTITY PER EQUIPT	NAME AND NOMENCLATURE	OVERALL DIMENSIONS (inches)	WEIGHT (lbs.)
1	Volt-Ohm-Milliammeter Navy Type 60046	3 X 4-1/2 X 7	2.5

UNCLASSIFIED

4.10 60046: 1

December 1956

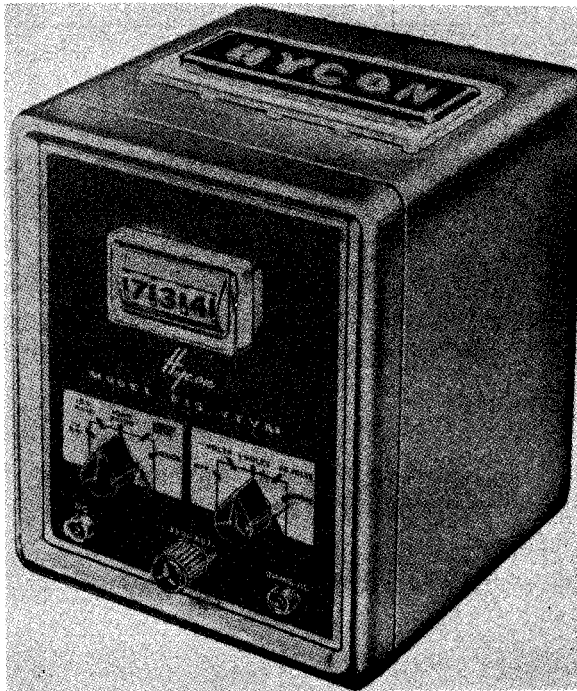
DIGITAL VACUUM TUBE VOLTOHMMETER**615**

Digital Vacuum Tube Volt-ohmmeter 615

FUNCTIONAL DESCRIPTION

The Hycon Model 615 is a portable digital vacuum tube volt-ohmmeter capable of measuring a wide range of voltages and resistance. DC voltages are measured with the use of a probe with a built-in isolating resistor. AC measurements are made with the use of a direct probe which is also used for resistance measurements. Ground connections are made through clips on the ends of flexible leads.

Three-digit indicating dials are used for all measurements. Automatically illuminated decimal points and polarity signs eliminate the possibility of making scale and polarity errors.

No field changes in effect at time of preparation (6 July 1956).

ELECTRICAL AND MECHANICAL CHARACTERISTICS**DC VOLTAGE MEASUREMENTS**

RANGES: 1, 10, 100 and 1000 v.

INPUT IMPEDANCE: 11 meg.

ACCURACY: $\pm 1\%$ of full scale.

AC VOLTAGE MEASUREMENTS

RANGES: 10, 100 and 1000 v RMS (measures peak to peak and indicated RMS of equivalent sine wave).

INPUT IMPEDANCE: 1.4 meg shunted by 60 uuf.
 ACCURACY: $\pm 2\%$ of full scale (for voltages greater than 1 v.)
 FREQUENCY RESPONSE: 30 cps to 3 mc with direct probe.
RESISTANCE MEASUREMENTS
 RANGES: 1 k, 10 k, 100 k, 1 meg, and 10 meg.
 ACCURACY: $\pm 1\%$ of full scale.
 MAXIMUM CURRENT THROUGH RESISTOR UNDER TEST:
 RX1, 2.7 ma; RX10, 0.27 ma; RX100, 27 ma; RX1K, 2.7 ma; RX10 k, 0.27 ma.
INDICATOR CHARACTERISTICS: Slewing time 5 sec max from 000 to 999; Damped for zero overshoot; Hysteresis ± 1 digit max.
SPURIOUS SIGNALS GENERATED: Appearing on the DC probe are less than 2 mv during slewing and are zero at balance.
RESPONSE TO SPURIOUS SIGNALS: A 60 cps signal with a peak to peak amplitude equal to the DC voltage being measured will cause an error of less than 0.5%. Signals of other frequency cause no error.
BATTERY COMPLEMENT: 3 Mercury cells at 1.35 v each.
POWER REQUIREMENTS: 105 to 125 v, 60 cps, single ph, 60 W (80 W off scale).

MANUFACTURER'S OR CONTRACTOR'S DATA

Hycon Mfg. Co., Pasadena, California.

TUBE AND/OR CRYSTAL COMPLEMENT

(1) 6BC7

(1) 12AT7

(2) 6AU6

(2) 6AQ5

Total Tubes: (6)

(1) CK706

Total Crystals: (1)

REFERENCE DATA AND LITERATURE

NAVSHIPS 92715: Technical Manual for Digital VTVM Model 615.

TYPE CLASSIFICATION
 DESIGN COGNIZANCE
 PROCUREMENT COGNIZANCE
 STOCK NO.
 R.D.B. IDENT. NO.

UNCLASSIFIED

4.10 615: 1

615

DIGITAL VACUUM TUBE VOLTOHMMETER

December 1956

EQUIPMENT SUPPLIED DATA

QUANTITY PER EQUIPT	NAME AND NOMENCLATURE	OVERALL DIMENSIONS (inches)	WEIGHT (lbs.)
1	Digital Vacuum Tube Voltohmmeter Model 615	7-1/2 X 8-1/2 X 11	19

March 1957

VOLT-OHM-MIL-AMMETER**625-N****FUNCTIONAL DESCRIPTION**

The 625-N is a long scale multi-range instrument in a compact portable case. It provides the ranges commonly used in servicing radio receivers as well as those used in the experimental laboratory or at radio transmitting stations.

No field changes in effect at time of preparation (19 September 1956).

1000, 5000 AC at 10,000 ohms per v.
 DECIBELS: -30 to +3, 15, 29, 43, 55, 69
 on 500 ohm line.
 OPERATING POWER: 4.5 v battery.

MANUFACTURER'S OR CONTRACTOR'S DATA

Triplett Electrical Instrument Co, Bluffton
 Ohio.

ELECTRICAL AND MECHANICAL CHARACTERISTICS**RANGES**

DC VOLTS: 0 to 1.25, 5.25, 125, 500,
 2500 at 20000 ohms per v.
 DC VOLTS: 0 to 2.5, 10, 50, 250, 1000,
 5000 at 10,000 ohms per v.
 AC VOLTS: 0 to 2.5, 10, 50, 250, 1000,
 5000 at 100,000 ohms per v.
 DC MILLIAMPERES: 0 to 1, 10, 100, 1000
 at 250 mv.
 DC MICROAMPERE: 0 to 50 at 250 mv.
 DC AMPERES: 0 to 10 at 250 mv.
 OHMS: 0 to 400, 50,000.
 MEGOHMS: 0 to 10.
 OUTPUT VOLTS: 0 to 2.5, 10, 50, 250,

TUBE AND/OR CRYSTAL COMPLEMENT

No Electron Tubes.

REFERENCE DATA AND LITERATURE

Technical Manual for Volt-Ohm-Mil-Ammeter
 625-N.

TYPE CLASSIFICATION
DESIGN COGNIZANCE
PROCUREMENT COGNIZANCE
STOCK NO.
R.D.B. IDENT. NO.

EQUIPMENT SUPPLIED DATA

QUANTITY PER EQUIP	NAME AND NOMENCLATURE	OVERALL DIMENSIONS (inches)	WEIGHT (lbs.)
1	Volt-Ohm-Mil-Ammeter		
2	Test Leads	50 lg	
1	Battery		

MULTIMETER

834

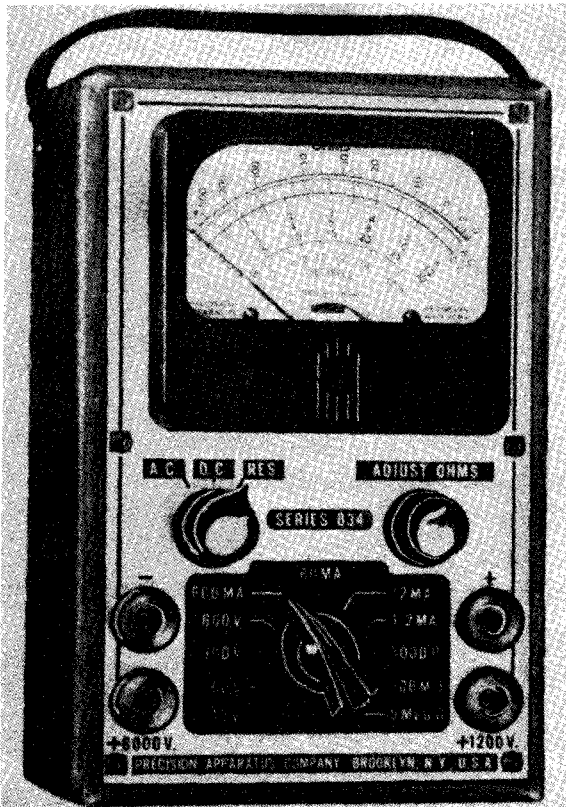

Multimeter Precision Series 834

EQUIPMENT REQUIRED BUT NOT SUPPLIED

(1) 45 v dry cell battery, Test leads.

ELECTRICAL AND MECHANICAL CHARACTERISTICS

SENSITIVITY: 1000 ohms per volt on all ranges.
DC VOLTAGE RANGES: 0 to 12, 0 to 60, 0 to 300, 0 to 600, 0 to 1200 and 0 to 6000 v.
AC VOLTAGE RANGES: 0 to 12, 0 to 60, 0 to 300, 0 to 600, 0 to 1200, and 0 to 6000 v.
DC CURRENT RANGES: 0 to 1.2, 0 to 12, 0 to 60, and 0 to 600 ma.
RESISTANCE RANGES: 0 to 5000 ohms, 0 to 0.5 megohms, and 0 to 5 megohms.
DECIBEL RANGES: -10 to +70 db.
OVER-ALL ACCURACY: 2% dc and 3% ac.

MANUFACTURER'S OR CONTRACTOR'S DATA

Precision Apparatus Co., Inc., Glendale, N.Y.

TUBE AND/OR CRYSTAL COMPLEMENT

No Electron Tubes or Crystals used.

REFERENCE DATA AND LITERATURE

Manufacturer's Catalog.

FUNCTIONAL DESCRIPTION

The Series 834 (Precision) Multimeter is designed as a compact direct current and alternating current circuit tester. A rotary selector switch allows all direct current and alternating current measurements except the 1200 and 6000 volt ranges to be made at only two tip jacks. It is capable of measuring voltage, current, resistance, and output power.

No field changes in effect at time of preparation (13 October 1958).

TYPE CLASSIFICATION
DESIGN COGNIZANCE
PROCUREMENT COGNIZANCE
STOCK NO.
R.D.B. IDENT. NO.

EQUIPMENT SUPPLIED DATA

QUANTITY PER EQUIPT	NAME AND NOMENCLATURE	OVERALL DIMENSIONS (inches)	WEIGHT (lbs.)
1	Multimeter, Precision Series 834	3 X 4-1/2 X 7	
1	3V Dry Cell Battery (Inclosed in Case)		